

STATE OF FLORIDA
DEPARTMENT OF ENVIRONMENTAL REGULATION

\$2,500 Pd.
5-19-89
Rept # 117618

NORTHEAST DISTRICT

3426 BILLS ROAD
JACKSONVILLE, FLORIDA 32207
(904) 396-6959

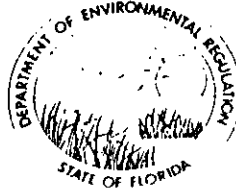

AC 05-165270

BOB GRAHAM
GOVERNOR
VICTORIA J. TSCHINKEL
SECRETARY
LINDSEY LEE
DISTRICT MANAGER

APPLICATION TO OPERATE/CONSTRUCT AIR POLLUTION SOURCES

SOURCE TYPE: Fiberglass Boat Plant [] New¹ [x] Existing¹
APPLICATION TYPE: [] Construction [x] Operation [] Modification
COMPANY NAME: Sea Ray Boats, INC COUNTY: Brevard

Identify the specific emission point source(s) addressed in this application (i.e. Lime
Kiln No. 4 with Venturi Scrubber; Peaking Unit No. 2, Gas Fired) Lamination &

SOURCE LOCATION: Street 100 Sea Ray Drive City Merritt Island
Fabrication Bldgs.

UTM: East _____ North _____

Latitude 28° 24' 32" N Longitude 80° 42' 23" W

APPLICANT NAME AND TITLE: Sea Ray Boats, INC

APPLICANT ADDRESS: 2600 Sea Ray Blvd, Knoxville, TN 37914

SECTION I: STATEMENTS BY APPLICANT AND ENGINEER

A. APPLICANT

I am the undersigned owner or authorized representative* of Sea Ray Boats, INC

I certify that the statements made in this application for a Boat Manuf. Plant permit are true, correct and complete to the best of my knowledge and belief. Further, I agree to maintain and operate the pollution control source and pollution control facilities in such a manner as to comply with the provision of Chapter 403, Florida Statutes, and all the rules and regulations of the department and revisions thereof. I also understand that a permit, if granted by the department, will be non-transferable and I will promptly notify the department upon sale or legal transfer of the permitted establishment.

*Attach letter of authorization

Signed: John A. Cronkhite

John Cronkhite, Vice-President
Name and Title (Please Type)

Date: 4/14/89 Telephone No. (615) 522-4181

B. PROFESSIONAL ENGINEER REGISTERED IN FLORIDA (where required by Chapter 471, F.S.)

This is to certify that the engineering features of this pollution control project have been designed/examined by me and found to be in conformity with modern engineering principles applicable to the treatment and disposal of pollutants characterized in the permit application. There is reasonable assurance, in my professional judgment, that

¹ See Florida Administrative Code Rule 17-2.100(57) and (104)

the pollution control facilities, when properly maintained and operated, will discharge an effluent that complies with all applicable statutes of the State of Florida and the rules and regulations of the department. It is also agreed that the undersigned will furnish, if authorized by the owner, the applicant a set of instructions for the proper maintenance and operation of the pollution control facilities and, if applicable, pollution sources.

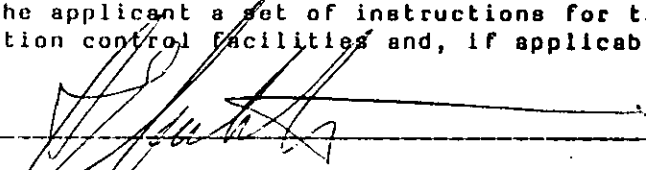
Signed 

G. E. Cantelou, Jr. P. E.
Name (Please Type)

Cantelou Associates, INC
Company Name (Please Type)

P. O. Box 3102, Aiken, SC 29802
Mailing Address (Please Type)

Florida Registration No. 18006 Date: Apr 3, 1989 Telephone No. (803) 648-9300

SECTION II: GENERAL PROJECT INFORMATION

A. Describe the nature and extent of the project. Refer to pollution control equipment, and expected improvements in source performance as a result of installation. State whether the project will result in full compliance. Attach additional sheet if necessary.

The existing facility produces fiberglass pleasure boats. The complete process is described in detail under Section V: Supplemental Requirements, Article 7

B. Schedule of project covered in this application (Construction Permit Application Only)

Start of Construction N/A Completion of Construction N/A

C. Costs of pollution control system(s): (Note: Show breakdown of estimated costs only for individual components/units of the project serving pollution control purposes. Information on actual costs shall be furnished with the application for operation permit.)

At present, the three Torrit dust collectors shown in Exhibit "D" - Part 2 (original cost not available; therefore, estimated cost \$40,000) are being replaced by the system outlined in Exhibit "D" - Part 3. The three Torrit dust collectors are being relocated to the Assembly Building. Location within that building is not determined. The collectors will be modified to be used as a central vacuum system for cleaning boats.

D. Indicate any previous DER permits, orders and notices associated with the emission point, including permit issuance and expiration dates.

Letter dated March 6, 1989, from A. Alexander P.E.

3840

E. Requested permitted equipment operating time: hrs/day 16; days/wk 5; wks/yr 48; if power plant, hrs/yr _____; if seasonal, describe: _____

F. If this is a new source or major modification, answer the following questions. (Yes or No) DOES NOT APPLY

- 1. Is this source in a non-attainment area for a particular pollutant? _____
 - a. If yes, has "offset" been applied? _____
 - b. If yes, has "Lowest Achievable Emission Rate" been applied? _____
 - c. If yes, list non-attainment pollutants. _____
- 2. Does best available control technology (BACT) apply to this source? If yes, see Section VI. _____
- 3. Does the State "Prevention of Significant Deterioration" (PSD) requirement apply to this source? If yes, see Sections VI and VII. _____
- 4. Do "Standards of Performance for New Stationary Sources" (NSPS) apply to this source? _____
- 5. Do "National Emission Standards for Hazardous Air Pollutants" (NESHAP) apply to this source? _____

H. Do "Reasonably Available Control Technology" (RACT) requirements apply to this source? DOES NOT APPLY

- a. If yes, for what pollutants? _____
- b. If yes, in addition to the information required in this form, any information requested in Rule 17-2.650 must be submitted.

Attach all supportive information related to any answer of "Yes". Attach any justification for any answer of "No" that might be considered questionable.

SECTION III: AIR POLLUTION SOURCES & CONTROL DEVICES (Other than Incinerators)

A. Raw Materials and Chemicals Used in your Process, if applicable:

Description	Contaminants		Utilization Rate - lbs/hr	Relate to Flow Diagram
	Type	% Wt		
Resin	Styrene	37	736.4	Step 2
Gelcoat	Styrene	30	125.7	Step 1
Gelcoat	Methyl Methacrylate	5	125.7	Step 1
MEKP9	MEKP	40	11.6	Steps 1,2
Acetone	Acetone	100	17.9	Steps 1,2,5

**CHART CONTINUED ON ATTACHED PAGE

B. Process Rate, if applicable: (See Section V, Item 1)

- Total Process Input Rate (lbs/hr): _____
- Product Weight (lbs/hr): _____

C. Airborne Contaminants Emitted: (Information in this table must be submitted for each emission point, use additional sheets as necessary)

Name of Contaminant	Emission ¹		Allowed ² Emission Rate per Rule 17-2	Allowable ³ Emission lbs/hr	Potential ⁴ Emission		Relate to Flow Diagram
	Maximum lbs/hr	Actual 1/yr			lbs/yr	T/yr	
Styrene	27.7	53.1	NOT DETERMINED	241,638	120.8	Step 1,2	
Methyl Methacrylate	6.3	12.1	NOT DETERMINED	54,906	27.5	Step 1	
MEKP	*	*	NOT DETERMINED	*	*	Step 1,2	
Acetone	17.9	51.6	NOT DETERMINED	111,709	55.8	Step 1,2,5	

¹See Section V, Item 2.

**CHART CONTINUED ON ATTACHED PAGE

²Reference applicable emission standards and units (e.g. Rule 17-2.600(5)(b)2. Table II, E. (1) - 0.1 pounds per million BTU heat input)

³Calculated from operating rate and applicable standard.

⁴Emission, if source operated without control (See Section V, Item 3).

* NEGLIGIBLE - SEE ATTACHED MSDS

SECTION III: AIR POLLUTION SOURCES & CONTROL DEVICES (Other than Incinerators)

A. Raw Materials and Chemicals Used in your Process, if applicable:

Description	Contaminants		Utilization Rate - lbs/hr	Relate to Flow Diagram
	Type	% Wt		
Glue (Adhesive)	1,1,1-Tri-chloroethane	60	2.52	Step 4
Glue (Adhesive)	Methylene Chloride	30	2.52	Step 4
Bottom Paint	Aromatic Hydrocarbon	16.2	21.95	Step 5
Bottom Paint	Xylene	6.3	21.95	Step 5

B. Process Rate, if applicable: (See Section V, Item 1)

1. Total Process Input Rate (lbs/hr): _____

2. Product Weight (lbs/hr): _____

C. Airborne Contaminants Emitted: (Information in this table must be submitted for each emission point, use additional sheets as necessary)

Name of Contaminant	Emission ¹		Allowed Emission Rate per Rule 17-2	Allowable Emission lbs/hr	Potential ⁴ Emission		Relate to Flow Diagram
	Maximum lbs/hr	Actual I/yr			lbs/yr	T/yr	
1,1,1-Tri-chloroethane	1.51	2.9	NOT DETERMINED		13,209	6.6	Step 4
Methylene Chloride	.76	1.4	NOT DETERMINED		6,640	3.3	Step 4
Aromatic Hydrocarbon	3.56	6.8	NOT DETERMINED		31,100	15.55	Step 3,4,5
Xylene	1.38	2.7	NOT DETERMINED		12,056	6.03	Step 3,4,5

¹See Section V, Item 2.

²Reference applicable emission standards and units (e.g. Rule 17-2.600(5)(b)2. Table II, E. (1) - 0.1 pounds per million BTU heat input)

³Calculated from operating rate and applicable standard.

⁴Emission, if source operated without control (See Section V, Item 3).

*There are other products used, but emissions would be insignificant - (i.e. spot remover, patching of parts, cleaners, etc.)

D. Control Devices: (See Section V, Item 4) DOES NOT APPLY

Name and Type (Model & Serial No.)	Contaminant	Efficiency	Range of Particles Size Collected (in microns) (If applicable)	Basis for Efficiency (Section V Item 5)

E. Fuels

Type (Be Specific)	Consumption*		Maximum Heat Input (MMBTU/hr)
	avg/hr	max./hr	

*Units: Natural Gas--MMCF/hr; Fuel Oils--gallons/hr; Coal, wood, refuse, other--lbs/hr.

Fuel Analysis:

Percent Sulfur: _____ Percent Ash: _____

Density: _____ lbs/gal Typical Percent Nitrogen: _____

Heat Capacity: _____ BTU/lb _____ BTU/gal

Other Fuel Contaminants (which may cause air pollution): _____

F. If applicable, indicate the percent of fuel used for space heating.

Annual Average _____ Maximum _____

G. Indicate liquid or solid wastes generated and method of disposal.

Contaminated acetone is recycled by licensed handlers offsite.

Solid waste generated is non-toxic and non-hazrdous and is disposed of offsite.

H. Emission Stack Geometry and Flow Characteristics (Provide data for each stack):

Stack Height: DOES NOT APPLY ft. Stack Diameter: _____ ft.
 Gas Flow Rate: _____ ACFM _____ DSCFM Gas Exit Temperature: _____ °F.
 Water Vapor Content: _____ % Velocity: _____ FPS

SECTION IV: INCINERATOR INFORMATION DOES NOT APPLY

Type of Waste	Type 0 (Plastics)	Type I (Rubbish)	Type II (Refuse)	Type III (Garbage)	Type IV (Pathological)	Type V (Liq. & Gas By-prod.)	Type VI (Solid By-prod.)
Actual lb/hr Incinerated							
Uncontrolled (lbs/hr)							

Description of Waste _____

Total Weight Incinerated (lbs/hr) _____ Design Capacity (lbs/hr) _____

Approximate Number of Hours of Operation per day _____ day/wk _____ wks/yr. _____

Manufacturer _____

Date Constructed _____ Model No. _____

	Volume (ft) ³	Heat Release (BTU/hr)	Fuel		Temperature (°F)
			Type	BTU/hr	
Primary Chamber					
Secondary Chamber					

Stack Height: _____ ft. Stack Diameter: _____ Stack Temp. _____

Gas Flow Rate: _____ ACFM _____ DSCFM* Velocity: _____ FPS

*If 50 or more tons per day design capacity, submit the emissions rate in grains per standard cubic foot dry gas corrected to 50% excess air.

Type of pollution control device: Cyclone Wet Scrubber Afterburner
 Other (specify) _____

Brief description of operating characteristics of control devices: _____

Ultimate disposal of any effluent other than that emitted from the stack (scrubber water, ash, etc.):

NOTE: Items 2, 3, 4, 6, 7, 8, and 10 in Section V must be included where applicable.

SECTION V: SUPPLEMENTAL REQUIREMENTS * SEE ATTACHMENT I

Please provide the following supplements where required for this application.

1. Total process input rate and product weight -- show derivation [Rule 17-2.100(127)]
2. To a construction application, attach basis of emission estimate (e.g., design calculations, design drawings, pertinent manufacturer's test data, etc.) and attach proposed methods (e.g., FR Part 60 Methods 1, 2, 3, 4, 5) to show proof of compliance with applicable standards. To an operation application, attach test results or methods used to show proof of compliance. Information provided when applying for an operation permit from a construction permit shall be indicative of the time at which the test was made.
3. Attach basis of potential discharge (e.g., emission factor, that is, AP42 test).
4. With construction permit application, include design details for all air pollution control systems (e.g., for baghouse include cloth to air ratio; for scrubber include cross-section sketch, design pressure drop, etc.)
5. With construction permit application, attach derivation of control device(s) efficiency. Include test or design data. Items 2, 3 and 5 should be consistent: actual emissions = potential (1-efficiency).
6. An 8 1/2" x 11" flow diagram which will, without revealing trade secrets, identify the individual operations and/or processes. Indicate where raw materials enter, where solid and liquid waste exit, where gaseous emissions and/or airborne particles are evolved and where finished products are obtained.
7. An 8 1/2" x 11" plot plan showing the location of the establishment, and points of airborne emissions, in relation to the surrounding area, residences and other permanent structures and roadways (Example: Copy of relevant portion of USGS topographic map).
8. An 8 1/2" x 11" plot plan of facility showing the location of manufacturing processes and outlets for airborne emissions. Relate all flows to the flow diagram.

- 9. The appropriate application fee in accordance with Rule 17-4.05. The check should be made payable to the Department of Environmental Regulation.
- 10. With an application for operation permit, attach a Certificate of Completion of Construction indicating that the source was constructed as shown in the construction permit.

SECTION VI: BEST AVAILABLE CONTROL TECHNOLOGY DOES NOT APPLY

A. Are standards of performance for new stationary sources pursuant to 40 C.F.R. Part 60 applicable to the source?

Yes No

Contaminant	Rate or Concentration

B. Has EPA declared the best available control technology for this class of sources (If yes, attach copy)

Yes No

Contaminant	Rate or Concentration

C. What emission levels do you propose as best available control technology?

Contaminant	Rate or Concentration

D. Describe the existing control and treatment technology (if any).

- | | |
|---------------------------|--------------------------|
| 1. Control Device/System: | 2. Operating Principles: |
| 3. Efficiency:* | 4. Capital Costs: |

*Explain method of determining

5. Useful Life:

6. Operating Costs:

7. Energy:

8. Maintenance Cost:

9. Emissions:

Contaminant

Rate or Concentration

Contaminant	Rate or Concentration

10. Stack Parameters

a. Height:

ft.

b. Diameter:

ft.

c. Flow Rate:

ACFM

d. Temperature:

°F.

e. Velocity:

FPS

E. Describe the control and treatment technology available (As many types as applicable, use additional pages if necessary).

1.

a. Control Device:

b. Operating Principles:

c. Efficiency:¹

d. Capital Cost:

e. Useful Life:

f. Operating Cost:

g. Energy:²

h. Maintenance Cost:

i. Availability of construction materials and process chemicals:

j. Applicability to manufacturing processes:

k. Ability to construct with control device, install in available space, and operate within proposed levels:

2.

a. Control Device:

b. Operating Principles:

c. Efficiency:¹

d. Capital Cost:

e. Useful Life:

f. Operating Cost:

g. Energy:²

h. Maintenance Cost:

i. Availability of construction materials and process chemicals:

¹Explain method of determining efficiency.

²Energy to be reported in units of electrical power - KWH design rate.

j. Applicability to manufacturing processes:

k. Ability to construct with control device, install in available space, and operate within proposed levels:

3.

a. Control Device:

b. Operating Principles:

c. Efficiency:¹

d. Capital Cost:

e. Useful Life:

f. Operating Cost:

g. Energy:²

h. Maintenance Cost:

i. Availability of construction materials and process chemicals:

j. Applicability to manufacturing processes:

k. Ability to construct with control device, install in available space, and operate within proposed levels:

4.

a. Control Device:

b. Operating Principles:

c. Efficiency:¹

d. Capital Costs:

e. Useful Life:

f. Operating Cost:

g. Energy:²

h. Maintenance Cost:

i. Availability of construction materials and process chemicals:

j. Applicability to manufacturing processes:

k. Ability to construct with control device, install in available space, and operate within proposed levels:

F. Describe the control technology selected:

1. Control Device:

2. Efficiency:¹

3. Capital Cost:

4. Useful Life:

5. Operating Cost:

6. Energy:²

7. Maintenance Cost:

8. Manufacturer:

9. Other locations where employed on similar processes:

a. (1) Company:

(2) Mailing Address:

(3) City:

(4) State:

¹Explain method of determining efficiency.

²Energy to be reported in units of electrical power - KWH design rate.

- (5) Environmental Manager:
- (6) Telephone No.:
- (7) Emissions:¹

Contaminant	Rate or Concentration

(8) Process Rate:¹

b. (1) Company:

(2) Mailing Address:

(3) City:

(4) State:

(5) Environmental Manager:

(6) Telephone No.:

(7) Emissions:¹

Contaminant	Rate or Concentration

(8) Process Rate:¹

10. Reason for selection and description of systems:

¹Applicant must provide this information when available. Should this information not be available, applicant must state the reason(s) why.

SECTION VII - PREVENTION OF SIGNIFICANT DETERIORATION DOES NOT APPLY

A. Company Monitored Data

1. _____ no. sites _____ TSP _____ () SO₂* _____ Wind spd/dir

Period of Monitoring _____ / _____ / _____ to _____ / _____ / _____
month day year month day year

Other data recorded _____

Attach all data or statistical summaries to this application.

*Specify bubbler (B) or continuous (C).

2. Instrumentation, Field and Laboratory

a. Was instrumentation EPA referenced or its equivalent? [] Yes [] No

b. Was instrumentation calibrated in accordance with Department procedures?
[] Yes [] No [] Unknown

B. Meteorological Data Used for Air Quality Modeling

1. _____ Year(s) of data from _____/_____/_____ to _____/_____/_____
month day year month day year

2. Surface data obtained from (location) _____

3. Upper air (mixing height) data obtained from (location) _____

4. Stability wind rose (STAR) data obtained from (location) _____

C. Computer Models Used

- 1. _____ Modified? If yes, attach description.
- 2. _____ Modified? If yes, attach description.
- 3. _____ Modified? If yes, attach description.
- 4. _____ Modified? If yes, attach description.

Attach copies of all final model runs showing input data, receptor locations, and principle output tables.

D. Applicants Maximum Allowable Emission Data

Pollutant	Emission Rate
TSP	_____ grams/sec
SO ₂	_____ grams/sec

E. Emission Data Used in Modeling

Attach list of emission sources. Emission data required is source name, description of point source (on NEDS point number), UTM coordinates, stack data, allowable emissions, and normal operating time.

F. Attach all other information supportive to the PSD review.

G. Discuss the social and economic impact of the selected technology versus other applicable technologies (i.e., jobs, payroll, production, taxes, energy, etc.). Include assessment of the environmental impact of the sources.

H. Attach scientific, engineering, and technical material, reports, publications, journals, and other competent relevant information describing the theory and application of the requested best available control technology.

ATTACHMENT I

SECTION V: SUPPLEMENTAL REQUIREMENTS

1. Not required.
2. See Attachment II.
3. Attached see Exhibit "A", Part 1 - excerpt from Cal-OSHA study indicating the emission factor for styrene from resins is 6%, and Emission Factors indicating the emission factor for gelcoat is approx. 30%, Part 2 - Product data sheets, and Part 3 - Potential Emissions Calculations.
4. Not required.
5. Not required.
6. See Exhibit "B".
7. See Exhibit "C".
8. See Exhibit "D".
9. Pending notice from DER.
10. Does Not Apply.

ATTACHMENT II

ACTUAL MATERIAL USAGE FOR 1988 AT SEA RAY, MERRITT ISLAND, FL
AS PROVIDED BY MR. ROB BOONE ON 3-21-89

RESIN	2,827,690 #	
GELCOAT	482,834 #	
MEKP-9	44,512 #	
GLUE	9,666 #	
BOTTOM PAINT	84,300 #	
ACETONE	535,568 #	(P.D.&E. & M.I.)
	318,165 #	(M.I. ONLY)
ACETONE RECYCLED		
	AT M.I. 97,068 #	

ATTACHMENT II

CALCULATIONS

ACTUAL UTILIZATION RATE FOR 1988

RESIN:
$$\frac{2,827,690 \text{ \#/yr}}{48 \text{ wk/yr} \times 5 \text{ day/wk} \times 16 \text{ hr/day}} = 736.4 \text{ \#/hr}$$

GEL COAT:
$$\frac{482,834 \text{ \#/yr}}{48 \text{ wk/yr} \times 5 \text{ day/wk} \times 16 \text{ hr/day}} = 125.7 \text{ \#/hr}$$

MEKP:
$$\frac{44,512 \text{ \#/yr}}{48 \text{ wk/yr} \times 5 \text{ day/wk} \times 16 \text{ hr/day}} = 11.6 \text{ \#/hr}$$

ACETONE:
$$\frac{318,165 \text{ \#/yr} - 97,068 \text{ \#/yr (recycled)} = 221,097 \text{ \#/yr (used)}}{48 \text{ wk/yr} \times 5 \text{ day/wk} \times 24 \text{ hr/day}} = 38.4 \text{ \#/hr} **$$

ADHESIVE:
$$\frac{9,666 \text{ \#/yr}}{48 \text{ wk/yr} \times 5 \text{ day/wk} \times 16 \text{ hr/day}} = 2.52 \text{ \#/hr}$$

BOTTOM PAINT:
$$\frac{84,300 \text{ \#/yr}}{48 \text{ wk/yr} \times 5 \text{ day/wk} \times 16 \text{ hr/day}} = 21.95 \text{ \#/hr}$$

* Hourly emissions based on 16 hour work day - 8 hour first shift and 8 hour skeleton shift in lamination

** These calculations are based on a yearly average, but in September Rez-Away was introduced as a cleaner. Before September approximately 1,600 gallons/week of acetone was being used. After Rez-Away was introduced approximately 600 gallons/week of acetone were used and 275 gallons/week of acetone were recycled. Therefore, future utilization rates based on these numbers would be:

600 gal/week

78 x 600 x 48 = 2,246,400 #/yr

ACETONE:
$$\frac{103,116 \text{ \#/yr}}{48 \text{ wk/yr} \times 5 \text{ day/wk} \times 24 \text{ hr/day}} = 17.9 \text{ \#/hr}$$

ATTACHMENT II

ACTUAL EMISSIONS (1988 USAGE)

EMISSIONS = (EMISSION RATE)(UTILIZATION RATE)(COMPONENT PERCENTAGE)

STRENE: RESIN $(.08)(736.4 \text{ \#/hr})(0.37)$
GEL COAT + $(.30)(125.7 \text{ \#/hr})(0.30) = 27.7 \text{ \#/hr} = 53.1 \text{ T/yr}$

METHYL METHACRALATE: $.02$
GEL COAT $(1.0)(125.7 \text{ \#/hr})(0.05) = 6.3 \text{ \#/hr} = 12.1 \text{ T/yr}$

ACETONE: **
ACETONE 318,165 (TOTAL) - 97,068 (RECYCLED) =
221,097 # emitted/yr = 38.4 #/hr = 110.6 T/yr

1,1,1-TRICHLOROETHANE: $.66$
 $(1.0)(2.52 \text{ \#/hr})(0.60) = 1.51 \text{ \#/hr} = 2.9 \text{ T/yr}$

METHYLENE CHLORIDE: $(1.0)(2.52 \text{ \#/hr})(0.30) = 0.76 \text{ \#/hr} = 1.4 \text{ T/yr}$

AROMATIC HYDROCARBON: $(1.0)(21.95 \text{ \#/hr})(.162) = 3.56 \text{ \#/hr} = 6.8 \text{ T/yr}$

XYLENE: $(1.0)(21.95 \text{ \#/hr})(0.63) = 1.38 \text{ \#/hr} = 2.7 \text{ T/yr}$

** ACTUAL EMISSIONS BASED ON NEW WEEKLY USE OF ACETONE WOULD BE:

$(600 \text{ GAL/WK (USED)} - 275 \text{ GAL/WK (RECYCLED)}) \times (6.61 \text{ \#/GAL}) \times (48 \text{ WKS/YR}) =$
 $103,116 \text{ \#/yr} = 17.9 \text{ \#/hr} = 51.56 \text{ T/yr}$

Occupational Exposures to Styrene and Other Health Hazards in the Fiberglass Reinforced Plastics Industry

A Special Studies Report by 

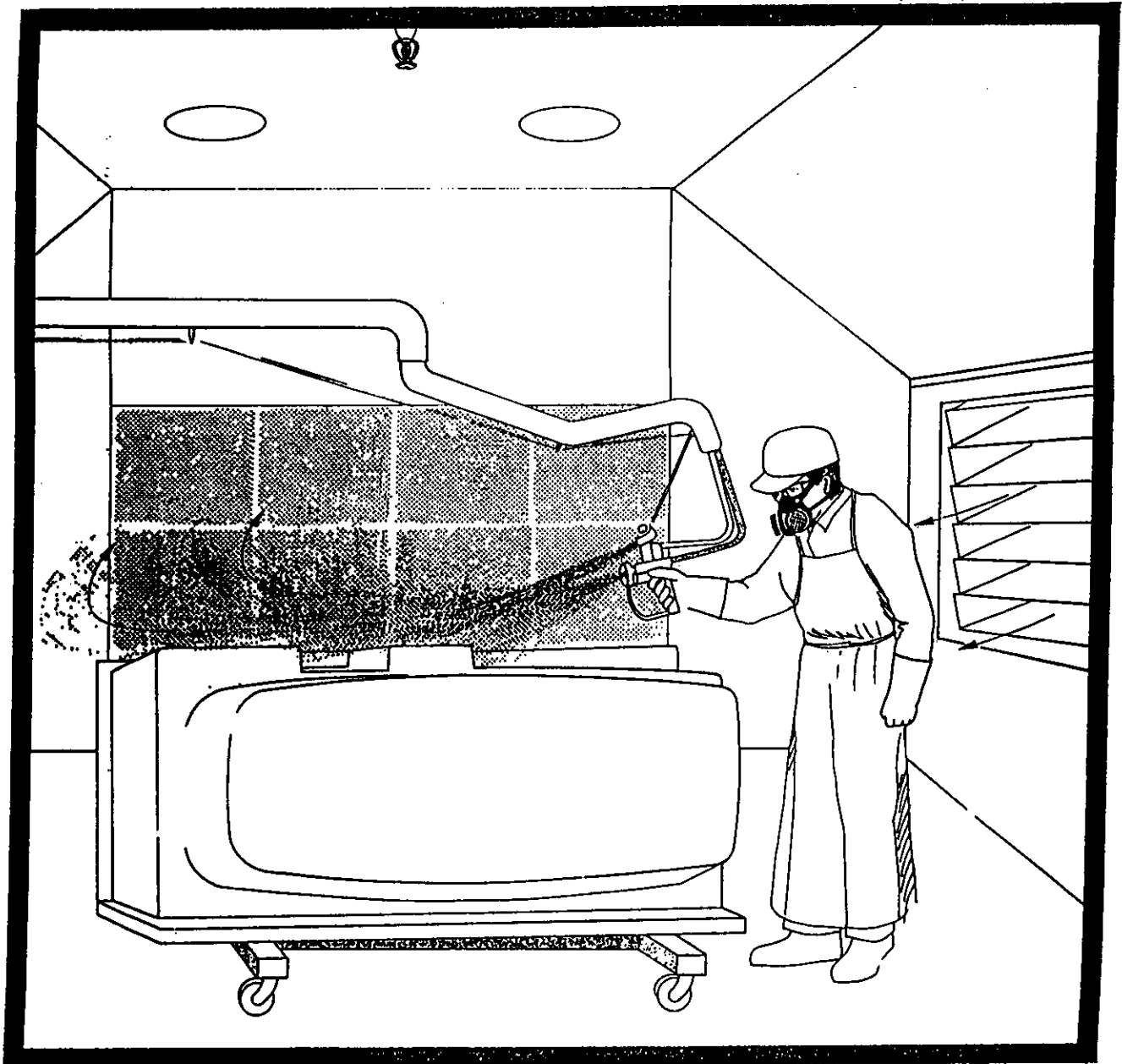

Department of Industrial Relations 
State of California
George Deukmejian, Governor
Ron Rinaldi, Director of Industrial Relations

worker performed almost continuous spraying while standing on a portable platform that was inserted into the tank that also supported a large duct with high velocity airflow that exhausted vapors very close to the point of generation.

Two facilities, using a unique production process to ensure good secondary bonding between resin layers, also had the side effect of obtaining low ambient exposure levels from the process. After gelcoating and hand laminating the mold, the part was covered with plastic sheeting and a vacuum pulled while the part is curing. Covering the part and pulling a vacuum through the space between the part and the plastic, removes styrene vapor from the work place air and reduces employee exposure.

The majority of companies which installed some form of dilution ventilation, for example, filter banks on the walls that pull a large volume of air, were mostly ineffective. They were either too far from the source of the exposure or were defeated by lack of directionality and turbulence.

Substitution

NIOSH estimates that approximately 6% of styrene monomer in a 40/60 polyester resin mixture vaporizes during the curing process. Methyl styrene (also called vinyl toluene) is a close chemical cousin of styrene that has a lower vapor pressure, reducing the amount of vaporization. Methyl styrene has three isomers, para, meta, or the ortho form. Two production facilities were using a resin mixture containing 60% polyester, 14% styrene and 26% para-methyl styrene.

FIGURE V.3

Styrene and the Three Isomers of Methyl Styrene

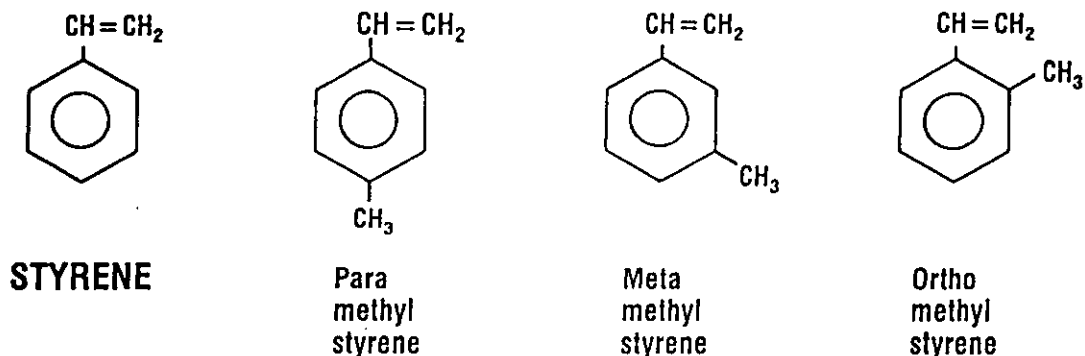

TABLE 4.12-2. EMISSION FACTORS FOR UNCONTROLLED POLYESTER RESIN
PRODUCT FABRICATION PROCESSES^a
(100 x mass of VOC emitted/mass of monomer input)

Process	Resin		Emission Factor Rating	Gel Coat		Emission Factor Rating
	NVS	Vsb		NVS	Vsb	
Hand layup	5 - 10	2 - 7	C	26 - 35	8 - 25	D
Spray layup	9 - 13	3 - 9	B	26 - 35	8 - 25	B
Continuous lamination	4 - 7	1 - 5	B	c	c	---
Pultrusion ^d	4 - 7	1 - 5	D	c	c	---
Filament winding ^e	5 - 10	2 - 7	D	c	c	---
Marble casting	1 - 3	1 - 2	B	f	f	---
Closed molding ^g	1 - 3	1 - 2	D	c	c	---

^aReference 9. Ranges represent the variability of processes and sensitivity of emissions to process parameters. Single value factors should be selected with caution. NVS = nonvapor-suppressed resin. VS = vapor-suppressed resin.

^bFactors are 30-70% of those for nonvapor-suppressed resins.

^cGel coat is not normally used in this process.

^dResin factors for the continuous lamination process are assumed to apply.

^eResin factors for the hand layup process are assumed to apply.

^fFactors unavailable. However, when cast parts are subsequently sprayed with gel coat, hand and spray layup gel coat factors are assumed to apply.

^gResin factors for marble casting, a semiclosed process, are assumed to apply.

TABLE 4.12-3. TYPICAL RESIN STYRENE PERCENTAGES

Resin Application	Resin Styrene Content ^a (wgt. %)
Hand layup	43
Spray layup	43
Continuous lamination	40
Filament winding	40
Marble casting	32
Closed molding	35
Gel coat	35

^aMay vary by at least ± 5 percentage points.

EXHIBIT "A" - PART 2

Material Safety Data Sheet

Alpha Resins Corporation
4620 N. Galloway Road
Lakeland, FL 33805

Product: UNSATURATED POLYESTER
RESIN
Internal ID: 80-603

MSDS No: ALPHA / 001
Revision: March 20, 1989
Date: March 20, 1989

National Paint
and Coatings
Association

Hazardous Material
Identification
System

HEALTH HAZARD	2
FLAMMABILITY HAZARD	3
REACTIVITY HAZARD	2
PERSONAL PROTECTION	I

SECTION I. MATERIAL IDENTIFICATION

Trade/Material Name: UNSATURATED POLYESTER RESIN

Description: Diacid/Glycol condensate

Other Designations: none

CAS: mixture

Trade Secret Register: N/A

Chemical Name: Polyester Resin

Manufacturer: Alpha Resins Corporation

Phone: (813) 858-4431

SECTION II. INGREDIENTS AND HAZARDS

Ingredient Name:	CAS Number:	Percent:	Exposure Limits:
Styrene	100-42-5	37%	50 ppm

SARA 313 INFORMATION: This product contains the above substance which is subject to the reporting requirements of section 313 of Title III of the Superfund Amendments and Reauthorization Act of 1986 and 40 CFR Part 372.

SECTION III. PHYSICAL DATA

Appearance & Odor: Viscous Liquid with a Sweet Pungent Odor.

Boiling point: 293°F
Vapor pressure: <4.5mmHg
Water solubility (%): very slight
Vapor density (air=1): 3.6
pH: N/A

Evaporation rate: 3.1
Specific gravity (H₂O=1): 1.0 - 1.1
Melting point: N/A
% volatile by volume: 43%
Molecular weight: undetermined

Material Safety Data Sheet

Alpha Resins Corporation
4620 N. Galloway Road
Lakeland, FL 33805

Product: UNSATURATED POLYESTER
RESIN
Internal ID: 80-603

MDS No: ALPHA / 001
Revision: March 20, 1989
Date: March 20, 1989

SECTION IV. FIRE AND EXPLOSION DATA

Flash Point (method): 88-92°F (CC) Limits: LEL %: 1.1 UEL %: 6.1

NFPA Flammable/Combustible Liquid Classification: 1C

NFPA Fire Hazard Symbol Codes: Flammability: 3 Health: 2 Reactivity: 2 Special: none

Extinguishing Media: water fog, dry chemical, foam or CO₂ Autoignition Temp:
914°F

Unusual fire or explosion hazards: At elevated temperatures, such as in a fire condition, polymerization may take place resulting in violent rupture of closed containers. Wear positive pressure apparatus, eye protection, and keep vapors away from possible ignition sources.

Special fire-fighting procedures: If electrical equipment is involved, the use of foam should be avoided. Handling equipment should be cooled by water stream if exposed to fire.

SECTION V. REACTIVITY DATA

Material is stable . Hazardous polymerization may occur .

Chemical incompatibilities: Acids, oxidizing agents, free radical initiators such as peroxides, and metallic halides and soaps.

Conditions to avoid: sunlight, open flames, contamination, and prolonged storage above 75°F.

Hazardous decomposition Products: carbon monoxide, carbon dioxide, and low molecular weight hydrocarbons.

SECTION VI. HEALTH HAZARD INFORMATION

This product is considered a possible carcinogen by IARC.*

Summary of risks: Causes irritation to throat, eyes, skin and nose. Harmful if inhaled.

Medical conditions which may be aggravated by contact: May aggravate pre-existing respiratory and skin disorders.

Target organs: CNS, respiratory system, lungs, eyes and skin.

Primary entry route(s): inhalation, ingestion, contact

Material Safety Data Sheet

Alpha Resins Corporation
4620 N. Galloway Road
Lakeland, FL 33805

Product: UNSATURATED POLYESTER
RESIN

Internal ID: 80-603

MSDS No: ALPHA / 001
Revision: March 20, 1989
Date: March 20, 1989

HEALTH HAZARD INFORMATION continued from page 2

Acute effects: May irritate eyes, nose, throat, and skin.

Chronic effect(s): May cause victim to feel drugged, sleepy or become unconscious. Repeated skin contact may cause rash. May affect the brain or nervous system, causing dizziness, headache or nausea. Reports have associated repeated and prolonged occupational overexposure to solvents with permanent brain and nervous system damage. Intentional misuse by deliberately concentrating and inhaling the contents may be harmful or fatal.

Signs & symptoms of overexposure:

Eye contact: Causes irritation to the eyes.

Skin contact: May cause irritation to the skin.

Inhalation: May irritate eyes, nose and throat. May feel drugged, sleepy, or unconscious.

Ingestion: May cause victim to become weak and unsteady.

First aid:

Eye contact: Immediately flush with plenty of water for at least 15 minutes. Get prompt medical attention. (Contact lenses should not be worn while working with this material.)

Skin contact: Wash exposed skin with soap and water. Get medical attention if irritation develops. Remove contaminated clothing, shoes, and thoroughly clean before reuse.

Inhalation: Move exposed person(s) to fresh air. Get medical attention.

Ingestion: DO NOT induce vomiting. Call Physician immediately.

*For hazard communication purposes under OSHA Standard 29 CFR Part 1910.1200, styrene is listed as a possible carcinogen by IARC. Neither the data from various long-term animal studies nor from epidemiology of workers exposed to styrene provide an adequate basis to conclude that styrene is carcinogenic.

Material Safety Data Sheet

Alpha Resins Corporation
4620 N. Galloway Road
Lakeland, FL 33805

Product: UNSATURATED POLYESTER
RESIN
Internal ID: 80-603

MDS No: ALPHA / 001
Revision: March 20, 1989
Date: March 20, 1989

SECTION VII. SPILL, LEAK AND DISPOSAL PROCEDURES

Spill / Leak procedures: Remove all sources of ignition. Ventilate area. Prevent material from entering drains. Absorbent should be vermiculite, dry sand or earth.

Small Spill - Soak up with absorbent and scoop into drums.

Large Spill - Dike and pump into drums.

Waste management / Disposal: Dispose of according to local, state and federal regulations.

SECTION VIII. SPECIAL PROTECTION INFORMATION**Personal protective equipment:**

Goggles: Use chemical goggles.

Gloves: Use gloves of rubber or other resistant material.

Respirator: Chemical cartridge respirator with NIOSH/OSHA approved organic vapor cartridge to 400 ppm. At exposures above 400 ppm use an SCBA.

Other: Use chemical resistant aprons or coats to avoid skin contact.

Workplace considerations:

Ventilation: Local exhaust is preferred. Mechanical ventilation is acceptable. Use explosion proof equipment.

Safety stations:

Safety showers and eye wash stations are recommended.

Contaminated equipment:

Clean contaminated equipment with an appropriate solvent prior to storage.

SECTION IX. SPECIAL PRECAUTIONS

Storage segregation: Store in a cool dry place away from incompatible materials.

Special handling / storage: Store in an area below 75°F and out of direct sunlight. Keep from heat, spark, and smoking areas. Empty containers may be hazardous.

Engineering controls: Equipment should be grounded during transfer and non-sparking pumps should be used.

Material Safety Data Sheet

Alpha Resins Corporation
4620 N. Galloway Road
Lakeland, FL 33805

Product: UNSATURATED POLYESTER
RESIN

Internal ID: 80-603

MSDS No: ALPHA / 001
Revision: March 20, 1989
Date: March 20, 1989

SPECIAL PRECAUTIONS continued from page 4

other precautions: Do not transfer to unlabeled bottles or containers.

DOT Class: Flammable Liquid

UN Register: UN-1866

Prepared/revised by: Pete Peterson

March 20, 1989

The information contained herein is based on the data available to us and is believed to be correct. No warranty, expressed or implied, is made regarding the accuracy of this data or the results to be obtained from the use thereof. Alpha Resins Corporation assumes no responsibility for injury from the use of the product described herein.

Gel Coat

JAN 18 1989

PAGE 01

MATERIAL SAFETY DATA SHEET

SECTION I - MANUFACTURERS INFORMATION

PRODUCT CODE/IDENTITY: 0044W969 PRODUCT NAME: WHITE WINTER-101/475
 NAME: COOK PAINT AND VARNISH COMPANY DATE OF MSDS: 04/29/88
 ADDRESS: P.O. BOX 419389 KANSAS CITY, MO 64141-6389 EMERGENCY TELEPHONE: 816-391-6000
 INFORMATION TELEPHONE: 816-391-6003

ATTN: SAFETY AND HEALTH OFFICER
 SEA RAY BOAT M.I.
 PO BOX 541257
 MERRIT ISLD FL 329541257

CUSTOMER NUMBER: 220094
 DATE PRINTED: 01/11/89
 COMPLEX: 700

SECTION II - HAZARDOUS INGREDIENTS

STYRENE MONOMER

CAS #: 000100-42-5 WT. %: 30.000 VAPOR PRESSURE: 4.5
 (MMHG/DEG F)

EXPOSURE LIMIT:
 ACGIH TLV/TWA: 50 PPM (SKIN) (215 MG/CU.M.)
 ACGIH TLV/STEL: 100 PPM (SKIN) (425 MG/CU.M.)
 OSHA PEL: 100 PPM (425 MG/CU.M.)
 OSHA PEL/CEILING: 200 PPM (850 MG/CU.M.)
 OTHER: OSHA: 600 PPM/5 MIN/3 HR PEAK

SILICA, AMORPHOUS

CAS #: 007631-86-9 WT. %: LESS THAN 5 VAPOR PRESSURE: N/A
 (MMHG/DEG F)

EXPOSURE LIMIT:
 ACGIH TLV/TWA: 10MG/CU.M. TOTAL DUST
 OSHA PEL: 20M PPCF AS DUST

MAGNESIUM HYDROXIDE (MAGNESIUM SILICATE)

CAS #: 014807-96-6 WT. %: 10.000 VAPOR PRESSURE: N/A
 (MMHG/DEG F)

EXPOSURE LIMIT:
 ACGIH TLV/TWA: 2 MG/M3 RESPIRABLE DUST
 OSHA PEL: 20 M PPCF

ETHYL METHACRYLATE

CAS #: 000080-62-6 WT. %: 5.000 VAPOR PRESSURE: 29.0
 (MMHG/DEG F)

EXPOSURE LIMIT:
 ACGIH TLV/TWA: 100 PPM (410 MG/CU.M.)
 OSHA PEL: 100 PPM (410 MG/CU.M.)

MAXIMUM VOC NOT CONSUMED DURING CURING IS 40 GRAM/LITER (OR 230 GRAMS/SQUARE
 METER OF SURFACE AREA OPEN TO AIR). MAXIMUM VOC OF UNCATALYZED RESINS AND GEL
 COATS IS 600 GRAMS/LITER.

THIS MATERIAL CONTAINS INGREDIENTS COVERED BY THE CALIFORNIA "SAFE DRINKING
 WATER AND TOXIC ENFORCEMENT ACT OF 1986" (PROPOSITION 65).

SECTION III - HEALTH HAZARD DATA

EFFECTS OF OVEREXPOSURE TO PRODUCT. PRIMARY ROUTES OF ENTRY ARE:

EYE CONTACT: IRRITATION. SYMPTOMS ARE TEARING, REDNESS AND DISCOMFORT.
 SKIN CONTACT: IRRITATION. CAN CAUSE DEFATTING OF SKIN WHICH MAY LEAD TO
 DERMATITIS.

MATERIAL SAFETY DATA SHEET

PRODUCT CODE IDENTITY: 944W969 PRODUCT NAME: WHITE-WINTER-101147

INHALATION: IRRITATION TO NOSE AND THROAT. EXTENDED OR REPEATED EXPOSURE TO CONCENTRATIONS ABOVE THE RECOMMENDED EXPOSURE LIMITS MAY CAUSE BRAIN OR NERVOUS SYSTEM DEPRESSION, CAUSING DIZZINESS, HEADACHE OR NAUSEA AND IF CONTINUED INDEFINITELY, LOSS OF CONSCIOUSNESS, LIVER AND KIDNEY DAMAGE.

REPORTS HAVE ASSOCIATED REPEATED OR PROLONGED OCCUPATIONAL OVEREXPOSURE TO SOLVENTS WITH PERMANENT BRAIN AND NERVOUS SYSTEM DAMAGE.

INGESTION: MAY CAUSE MOUTH, THROAT, ESOPHAGUS AND STOMACH IRRITATION, NAUSEA, VOMITING AND DIARRHEA.

MEDICAL CONDITIONS THAT MAY BE AGGRAVATED BY EXPOSURE TO THIS PRODUCT:
PREEXISTING EYE, SKIN, LIVER, KIDNEY AND RESPIRATORY DISORDERS.

EMERGENCY AND FIRST AID PROCEDURES:

IN CASE OF EYE CONTACT, FLUSH IMMEDIATELY WITH PLENTY OF WATER FOR AT LEAST 15 MINUTES AND GET MEDICAL ATTENTION; FOR SKIN, WASH THOROUGHLY WITH SOAP AND WATER. IF AFFECTED BY INHALATION OF VAPORS OR SPRAY MIST, REMOVE TO FRESH AIR. IF SWALLOWED, GET MEDICAL ATTENTION IMMEDIATELY.

OTHER HEALTH HAZARDS:

THE INTERNATIONAL AGENCY FOR RESEARCH ON CANCER (IARC) HAS RECLASSIFIED STYRENE AS GROUP 2B "POSSIBLY CARCINOGENIC TO HUMANS". THIS NEW CLASSIFICATION IS NOT BASED ON NEW HEALTH DATA RELATING TO EITHER HUMANS OR ANIMALS, BUT ON A CHANGE IN THE IARC CLASSIFICATION SYSTEM. THE STYRENE INFORMATION AND RESEARCH CENTER DOES NOT AGREE WITH THE RECLASSIFICATION AND HAS PUBLISHED THE FOLLOWING STATEMENT. "RECENTLY PUBLISHED STUDIES TRACING 50,000 WORKERS EXPOSED TO HIGH OCCUPATIONAL LEVELS OF STYRENE OVER A PERIOD OF 45 YEARS SHOWED NO ASSOCIATION BETWEEN STYRENE AND CANCER, NO INCREASE IN CANCER AMONG STYRENE WORKERS (AS OPPOSED TO THE AVERAGE AMONG ALL WORKERS), AND NO INCREASE IN MORTALITY RELATED TO STYRENE."

SECTION IV - PHYSICAL DATA

BOILING POINT, DEG. F. 212

VAPOR DENSITY IS HEAVIER THAN AIR

WEIGHT PER GALLON: 10.87

EVAPORATION RATE IS SLOWER THAN ETHER

PERCENT VOLATILE BY VOLUME: 53.651

SECTION V - FIRE AND EXPLOSION HAZARD DATA

OSHA FLAMMABILITY CLASSIFICATION: FLAMMABLE LIQUID CLASS IC

FLASH POINT SETA CLOSED CUP, DEG F: 82

DOT HAZARD CLASS: RED-LABEL, FLAMMABLE LIQUID

LEL: 1.10

EXTINGUISHING MEDIA: FOAM, CARBON DIOXIDE, DRY CHEMICAL, WATER FOG.

UNUSUAL FIRE AND EXPLOSION HAZARDS:

IF POLYMERIZATION TAKES PLACE IN A CONTAINER, THERE IS POSSIBILITY OF VIOLENT RUPTURE OF THE CONTAINER. STYRENE VAPORS ARE UNINHIBITED AND MAY FORM POLYMERS IN VENTS OR FLAME ARRESTORS OF STORAGE TANKS RESULTING IN STOPPAGE OF VENTS. VAPORS MAY CAUSE FLASH FIRE. KEEP CONTAINERS TIGHTLY CLOSED AND ISOLATE FROM HEAT, ELECTRICAL EQUIPMENT, SPARKS AND FLAME. NEVER USE WELDING OR CUTTING TORCH ON OR NEAR DRUM (EVEN EMPTY) BECAUSE PRODUCT (EVEN JUST RESIDUE) CAN IGNITE EXPLOSIVELY.

SPECIAL FIRE FIGHTING PROCEDURES:

FULL PROTECTIVE EQUIPMENT INCLUDING SELF-CONTAINED BREATHING APPARATUS SHOULD BE USED. WATER SPRAY MAY BE INEFFECTIVE. IF WATER IS USED, FOG NOZZLES ARE PREFERABLE. WATER MAY BE USED TO COOL CLOSED CONTAINERS TO PREVENT PRESSURE BUILD-UP AND POSSIBLE AUTO-IGNITION OR EXPLOSION WHEN EXPOSED TO EXTREME HEAT.

MATERIAL SAFETY DATA SHEET

PAGE 03

PRODUCT CODE IDENTITY: 944WS69 PRODUCT NAME: WHITE-WINTER-101147

SECTION VI - REACTIVITY DATA

STABILITY: STABLE HAZARDOUS POLYMERIZATION: MAY OCCUR.

CONDITIONS TO AVOID:

ELEVATED TEMPERATURES. IMPROPER ADDITION OF PROMOTER AND/OR CATALYST. AVOID DIRECT CONTACT OF MEKP CATALYST WITH ACCELERATOR. IF AN ACCELERATOR SUCH AS COBALT DRIER IS TO BE ADDED, MIX THIS ACCELERATOR WITH BASE MATERIAL BEFORE ADDING CATALYST.

INCOMPATIBILITY (MATERIALS TO AVOID):

OXIDIZERS, PEROXIDES, STRONG ACIDS, ALUMINUM CHLORIDE AND VINYL POLYMERS.

HAZARDOUS DECOMPOSITION PRODUCTS:

THERMAL DECOMPOSITION OR COMBUSTION CAN PRODUCE FUMES CONTAINING ORGANIC ACIDS, CARBON DIOXIDE AND CARBON MONOXIDE.

SECTION VII - SPILL OR LEAK PROCEDURES

STEPS TO BE TAKEN IN CASE MATERIAL IS RELEASED OR SPILLED:

REMOVE ALL SOURCES OF IGNITION (FLAMES, HOT SURFACES, AND ELECTRICAL, STATIC, OR FRICTIONAL SPARKS). AVOID BREATHING VAPORS. VENTILATE AREA. CONTAIN AND REMOVE WITH INERT ABSORBENT AND NON-SPARKING TOOLS.

WASTE DISPOSAL METHOD:

DISPOSE OF IN ACCORDANCE WITH LOCAL, STATE AND FEDERAL REGULATIONS. DO NOT INCINERATE CLOSED CONTAINERS. INCINERATE IN APPROVED FACILITY.

SECTION VIII - SPECIAL PROTECTION INFORMATION

RESPIRATORY PROTECTION:

DO NOT BREATHE OR INGEST VAPORS, SPRAY MIST OR DUST WHILE APPLYING, SANDING, GRINDING, OR SAWING CURED PRODUCT. WEAR AN APPROPRIATE, PROPERLY FITTED RESPIRATOR (NIOSH/MSHA APPROVED) DURING APPLICATION AND OTHER USE OF THIS PRODUCT UNTIL ALL VAPORS, MISTS, AND DUSTS ARE EXHAUSTED, UNLESS AIR MONITORING DEMONSTRATES VAPOR AND MIST AND DUST LEVELS ARE BELOW APPLICABLE LIMITS. FOLLOW RESPIRATOR MANUFACTURER'S DIRECTIONS FOR RESPIRATOR USE. OBSERVE OSHA STANDARD 29CFR 1910.134.

VENTILATION:

PROVIDE GENERAL CLEAN AIR DILUTION OR LOCAL EXHAUST VENTILATION IN VOLUME AND PATTERN TO KEEP THE AIR CONTAMINANT CONCENTRATION BELOW THE LOWER EXPLOSION LIMIT AND BELOW CURRENT APPLICABLE EXPOSURE LIMITS IN THE MIXING, APPLICATION AND CURING AREAS; AND TO REMOVE DECOMPOSITION PRODUCT DURING WELDING AND FLAME CUTTING ON SURFACES COATED WITH THIS PRODUCT. IN CONFINED AREAS, USE ONLY WITH FORCED VENTILATION ADEQUATE TO KEEP VAPOR CONCENTRATION BELOW 20% OF LOWER EXPLOSION LIMITS. REFER TO OSHA STANDARDS 29CFR 1910.94, 1910.107, 1910.108.

NOTE: HEAVY SOLVENT VAPORS SHOULD BE REMOVED FROM LOWER LEVELS OF THE WORK AREA AND ALL IGNITION SOURCES (NONEXPLOSION-PROOF MOTORS, ETC.) SHOULD BE ELIMINATED.

PROTECTIVE GLOVES: USE SOLVENT IMPERMEABLE GLOVES TO AVOID CONTACT WITH PRODUCT

EYE PROTECTION:

DO NOT GET IN EYES. USE SAFETY EYEWEAR WITH SPLASH GUARDS OR SIDE SHIELDS, CHEMICAL GOGGLES, FACE SHIELDS.

OTHER PROTECTIVE EQUIPMENT:

AVOID CONTACT WITH SKIN. USE PROTECTIVE CLOTHING. PREVENT CONTACT WITH CONTAMINATED CLOTHING. WASH CONTAMINATED CLOTHING, INCLUDING SHOES, BEFORE REUSE.

GEL COAT

MATERIAL SAFETY DATA SHEET

PAGE 04

PRODUCT CODE IDENTITY: 944W969

PRODUCT NAME: WHITE-WINTER-101177

SECTION IX - SPECIAL PRECAUTIONS

PRECAUTIONS TO BE TAKEN IN HANDLING AND STORAGE:

DO NOT STORE ABOVE 120 DEG. F. STORE LARGE QUANTITIES IN BUILDINGS DESIGNED TO COMPLY WITH OSHA 1910.106. KEEP AWAY FROM HEAT, SPARKS AND FLAME. KEEP CONTAINERS CLOSED WHEN NOT IN USE AND UPRIGHT TO PREVENT LEAKAGE.

OTHER PRECAUTIONS:

CONTAINERS SHOULD BE GROUNDED WHEN POURING. DO NOT TAKE INTERNALLY. WASH HANDS AFTER USING AND BEFORE SMOKING OR EATING. EMPTIED CONTAINERS MAY RETAIN HAZARDOUS RESIDUE AND EXPLOSIVE VAPORS. KEEP AWAY FROM HEAT, SPARKS AND FLAMES. DO NOT CUT, PUNCTURE OR WELD ON OR NEAR EMPTIED CONTAINERS. FOLLOW ALL HAZARD PRECAUTIONS GIVEN IN THIS DATA SHEET UNTIL CONTAINER IS THOROUGHLY CLEANED OR DESTROYED. IF THIS PRODUCT IS BLENDED WITH OTHER COMPONENTS SUCH AS THINNERS, CONVERTER, COLORANTS AND CATALYSTS PRIOR TO USE, READ ALL WARNING LABELS. ANY MIXTURE OF COMPONENTS WILL HAVE HAZARDS OF ALL COMPONENTS. FOLLOW ALL PRECAUTIONS. IF SPRAYING THIS MATERIAL, KEEP SPRAY BOOTHS CLEAN. AVOID BUILDUP OF SPRAY DUST OR OVERSPRAY IN BOOTHS OR DUCTS.

KEEP OUT OF REACH OF CHILDREN

FOR INDUSTRIAL USE ONLY

SECTION X - SARA TITLE III INFORMATION

THIS PRODUCT CONTAINS THE FOLLOWING TOXIC CHEMICALS SUBJECT TO THE REPORTING REQUIREMENTS OF SECTION 313 OF SARA TITLE III EMERGENCY PLANNING AND COMMUNITY RIGHT-TO-KNOW ACT OF 1986 AND OF 40 CFR PART 372.

CHEMICAL NAME	CAS NUMBER	% BY WEIGHT	SARA TITLE III SECTION 311 AND 312 HAZARD CATEGORIES
STYRENE MONOMER	000100-42-5	32.0830	IMMEDIATE (ACUTE) DELAYED (CHRONIC) FIRE HAZARD REACTIVE
METHYL METHACRYLATE	000080-62-6	4.7270	IMMEDIATE (ACUTE) FIRE HAZARD REACTIVE

DISCLAIMER AND LIMITATION OF LIABILITY

TO THE BEST OF OUR KNOWLEDGE, THE INFORMATION CONTAINED HEREIN IS ACCURATE. TO THE EXTENT ALLOWED BY LAW, THIS STATEMENT IS MADE IN LIEU OF ANY OTHER WARRANTIES, EXPRESSED OR IMPLIED, INCLUDING BUT NOT LIMITED TO ANY IMPLIED WARRANTY OF MERCHANTABILITY OR FITNESS FOR A PARTICULAR PURPOSE, AND IS IN LIEU OF ANY OTHER OBLIGATIONS OR LIABILITY ON THE PART OF COOK PAINT AND VARNISH COMPANY.

COOK PAINT AND VARNISH COMPANY WILL NOT BE LIABLE FOR ANY INCIDENTAL OR CONSEQUENTIAL DAMAGES. FINAL DETERMINATION OF THE SUITABILITY OF THE MATERIAL FOR THE USE CONTEMPLATED, THE MANNER OF USE, AND WHETHER THE SUGGESTED USE INFRINGES ANY PATENT IS THE SOLE RESPONSIBILITY OF THE BUYER.

Please see attached sheet

WITCO MATERIAL SAFETY DATA SHEET

HI-POINT(R) PD-1

PAGE 1

CAS NO: 1338-23-4

DIVISION AND LOCATION---SECTION I

Division: ARGUS-US PEROXYGEN PRODUCTS

Location: RICHMOND, CA

850 MORTON AVE., RICHMOND, CA, 94806

Emergency Telephone Number: (415) 233-5911 OR (214) 938-5141 (MARSHALL, TX)

Transportation Emergency: CHEM TREC 1-(800) 424-9300 (U.S. and Canada)

CHEMICAL AND PHYSICAL PROPERTIES---SECTION II

Chemical Name:

methyl ethyl ketone peroxide

Formula: not applicable

Hazardous Decomposition Products:

carbon monoxide and carbon dioxide from burning.

Incompatibility (Keep away from):

strong acids, bases, promoters, accelerators, readily oxidizables, and metal salts.

Toxic and Hazardous Ingredients:

methyl ethyl ketone peroxide

(active oxygen)

dimethylphthalate

40% *
5.25 max.

CAS #
1338-23-4

131-11-3

Form: liquid

Odor: slightly pungent

Appearance: clear

Color: water-white

Specific Gravity (water=1): 1.133

Boiling Point: no data available, decomposes over 68°C (155°F)

Melting Point: not applicable

Solubility in Water (by weight %): less than 1 at 25°C

Volatile (by weight %): less than 3

Evaporation Rate: not applicable

Vapor Pressure (mm Hg at 20°C): not applicable

Vapor Density (air=1): not applicable

pH (As is): no data available

Stability: Product is stable when stored at recommended temperatures

Viscosity SUS at 100°F: 15 centistokes at 25°C (77°F)

Other physical properties:

self accelerating decomposition temperature (SADT): 4 gal: 76°C (169°F)

1 gal: 79°C (175°F)

FIRE AND EXPLOSION DATA---SECTION III

Special Fire Fighting Procedures:

Fight fire with large amounts of water from a safe distance. Keep containers cool with water spray. After a fire, wait until material has cooled to room temperature before starting clean-up. Wear protective equipment to prevent smoke inhalation.

(Continued on next page)

WITCO MATERIAL SAFETY DATA SHEET

HI-POINT(R) PD-1

PAGE 2

(Section III continued)

Unusual Fire and Explosion Hazards:

Potential explosion hazards. Once ignited, product will burn vigorously.

Flashpoint: (Method Used) Setaflash closed tester 85°C (185°F)

Flammable limits: not applicable

Extinguishing agents:

Drychemical or Waterspray or Waterfog or CO₂ or Foam

Closed containers exposed to fire may be cooled with water.

HEALTH HAZARD DATA---SECTION IV

Permissible concentrations (air):

methyl ethyl ketone peroxide: 0.2 ppm ceiling (ACGIH)

dimethylphthalate: 5 mg/m³ (OSHA/ACGIH)

Chronic effects of overexposure:

Specific symptoms and effects of over exposure not known, but will cause severe eye irritation; may cause blindness. Harmful if inhaled. Harmful or fatal if swallowed. Moderate skin irritant.

Acute toxicological properties:

for methyl ethyl ketone peroxide: acute oral LD₅₀ = 500-5000 mg/kg (rat);

moderate skin irritant (rabbit)

Emergency First Aid Procedures:

Eyes: Immediately flush with large quantities of water on site for 20 to 30 minutes. Hold eyes open while flushing. Call a physician. Continue water flush up to one hour during transport to a medical facility.

Skin Contact: Wash with soap and water. If irritation occurs, see a physician.

Inhalation: Remove to fresh air. Consult a physician if discomfort persists.

If Swallowed: Administer large quantities of water if person is conscious.

Never give anything by mouth to an unconscious person.
Immediately contact a physician.

SPECIAL PROTECTION INFORMATION---SECTION V

Ventilation Type Required (Local, mechanical, special):

Local if necessary to maintain allowable PEL(permissible exposure limit) or TLV(threshold limit value)

Respiratory Protection (Specify type):

Use NIOSH/OSHA approved respirator with organic vapor cartridge if vapor concentration exceeds permissible exposure limit

Protective Gloves:

neoprene type

Eye Protection:

chemical safety goggles

Other Protective Equipment:

as required to protect against skin contact

(Continued on next page)

WITCO MATERIAL SAFETY DATA SHEET

HI-POINT(R) 90 RED

PAGE 3

HANDLING OF SPILLS OR LEAKS---SECTION VI

Procedures for Clean-Up:

Use appropriate protective clothing during clean-up. Absorb spills with inert material such as perlite, vermiculite, or sand and then wet with water. Sweep up using non-sparking equipment and place in double polyethylene bags. Isolate leakers and contaminated containers to a safe place for disposal.

Waste Disposal:

Dispose of in accordance with all applicable federal, state and local regulations.

Dispose of waste at EPA-approved hazardous waste disposal facilities.

SPECIAL PRECAUTIONS---SECTION VII

Precautions to be taken in handling and storage:

Store in original containers away from promoters and combustible material. Keep away from acids, heat, sparks, flames and direct sunlight. Keep closed to avoid contamination. Isolated storage is desirable.

Maximum Storage Temperature: 38°C (100°F)

TRANSPORTATION DATA---SECTION VIII

D.O.T.: Regulated

U.S. D.O.T. Proper Shipping Name: Methyl ethyl ketone peroxide, 9% maximum active oxygen

U.S. D.O.T. Hazard Class: Organic Peroxide

I.D. Number: UN 2550

Label(s) Required: Organic Peroxide

Reportable Quantity: 10 LB/4.54 KG (for 2-butanone peroxide (or methyl ethyl ketone peroxide))

Freight Classification: Chemicals, NOI, N.F.M.C. Item 43940 Sub 2

Special Transportation Notes:

none

ENVIRONMENTAL/SAFETY REGULATIONS---SECTION IX

Section 313 (Title III Superfund Amendment and Reauthorization Act):

This product contains the following chemical(s) subject to the reporting requirements of Section 313 of Title III of the Superfund Amendments and Reauthorization Act of 1986 and 40 CFR Part 372 (the corresponding CAS number and percent by weight are also provided):

dimethyl phthalate CAS# 131-11-3 47%

methyl ethyl ketone CAS#78-93-3 2%

(Continued on next page)

WITCO MATERIAL SAFETY DATA SHEET

HI-POINT(R) 90 RED

PAGE 4

COMMENTS

Never mix any promoter or accelerator with product as very rapid or explosive decomposition could occur. Do not store with food or drink.

Signature: Roger N. Lewis _____

Title: Vice President-Research

Original Date: _____ Sent to: _____

Revision Date: 12/07/88

Supersedes: 06/18/87

Date Sent: _____

We believe the statements, technical information and recommendations contained herein are reliable, but they are given without warranty or guarantee of any kind, express or implied, and we assume no responsibility for any loss, damage, or expense, direct or consequential, arising out of their use.

ATTACHMENT TO MEKP MATERIAL SAFETY DATA SHEET

Per phone conversation on 3-27-89 with chemist Ron Pastorino of Witco, U. S. Peroxygen Products, Argus Division, we were advised that the MEKP is approximately 40% of the product and that almost all components are totally consumed. Much less than 3% is volatilized and that the 3% is mainly made up of water and trace MEK and if any is MEKP it was a negligible amount.

MATERIAL SAFETY
DATA SHEET

003980

ACETONE

Page: 1

THIS MSDS COMPLIES WITH 29 CFR 1910.1200 (THE HAZARD COMMUNICATION STANDARD)

Product Name: ACETONE
CAS NUMBER: 67-64-1

05 50 093 7988090-

Data Sheet No: 0004335-004
Prepared: 12/22/88
Supersedes: 03/04/86SEA-RAY BOATS INC
100 SEA RAY DR
MERRITT ISLAND FL 32952PRODUCT: 3010000
INVOICE: 120472
INVOICE DATE: 02/21/89
TO: SEA-RAY BOATS INC
100 SEA RAY DR
MERRITT ISLAND

FL 32952

ATTN: PLANT MGR./SAFETY DIR.

SECTION I - PRODUCT IDENTIFICATION

General or Generic ID: KETONE

DOT Hazard Classification: FLAMMABLE LIQUID (173.115)

SECTION II - COMPONENTS

IF PRESENT, IARC, NTP AND OSHA CARCINOGENS AND CHEMICALS SUBJECT TO THE REPORTING REQUIREMENTS OF SARA TITLE III SECTION 313 ARE IDENTIFIED IN THIS SECTION. SEE DEFINITION PAGE FOR CLARIFICATION

INGREDIENT	% (by WT)	PEL	TLV	Note
ACETONE CAS #: 67-64-1	100	1000 PPM	750 PPM	(1)

Notes:

(1) ACGIH - SHORT TERM EXPOSURE LIMIT (STEL) FOR ACETONE IS 1000 PPM. NIOSH RECOMMENDS A LIMIT OF 250 PPM, 8-HOUR TWA.

THIS CHEMICAL IS SUBJECT TO THE REPORTING REQUIREMENTS OF SECTION 313 OF SARA TITLE III.

SECTION III - PHYSICAL DATA

Boiling Point	for PRODUCT	133.00 Deg F (56.11 Deg C) 760.00 mm Hg
Vapor Pressure	for PRODUCT	181.70 mm Hg (68.00 Deg F) 20.00 Deg C)
Specific Vapor Density	AIR = 1	2.0
Specific Gravity		.785 - .788 (77.00 Deg F) (25.00 Deg C)
Percent Volatiles		100.00%
Evaporation Rate	(N-BUTYL ACETATE = 1)	6.00

SECTION IV - FIRE AND EXPLOSION INFORMATION

FLASH POINT(TCC) 0.0 Deg F (-17.8 Deg C)

EXPLOSIVE LIMIT (PRODUCT) LOWER - 2.6% UPPER - 12.8%

EXTINGUISHING MEDIA: ALCOHOL FOAM OR CARBON DIOXIDE OR DRY CHEMICAL

HAZARDOUS DECOMPOSITION PRODUCTS: MAY FORM TOXIC MATERIALS: , CARBON DIOXIDE AND CARBON MONOXIDE, VARIOUS HYDROCARBONS, ETC.

FIREFIGHTING PROCEDURES: WEAR SELF-CONTAINED BREATHING APPARATUS WITH A FULL FACEPIECE OPERATED IN THE POSITIVE PRESSURE DEMAND MODE WHEN FIGHTING FIRES.

SPECIAL FIRE & EXPLOSION HAZARDS: MATERIAL IS HIGHLY VOLATILE AND READILY GIVES OFF VAPORS WHICH MAY TRAVEL ALONG THE GROUND OR BE MOVED BY VENTILATION AND IGNITED BY PILOT LIGHTS, OTHER FLAMES, SPARKS, HEATERS, SMOKING, ELECTRIC MOTORS, STATIC DISCHARGE, OR OTHER IGNITION SOURCES AT LOCATIONS DISTANT FROM MATERIAL HANDLING POINT.

NEVER USE WELDING OR CUTTING TORCH ON OR NEAR DRUM (EVEN EMPTY) BECAUSE PRODUCT (EVEN JUST RESIDUE) CAN IGNITE EXPLOSIVELY.

ALL FIVE GALLON PAILS AND LARGER METAL CONTAINERS INCLUDING TANK CARS AND TANK TRUCKS SHOULD BE GROUNDED AND/OR BONDED WHEN MATERIAL IS TRANSFERRED.

NFPA CODES: HEALTH- 1 FLAMMABILITY- 3 REACTIVITY- 0

SECTION V - HEALTH HAZARD INFORMATION

PERMISSIBLE EXPOSURE LEVEL 1000 PPM

THRESHOLD LIMIT VALUE 750 PPM

SEE SECTION II

**MATERIAL SAFETY
DATA SHEET**

24-HOUR EMERGENCY TELEPHONE (606) 324-1133

003980

ACETONE

Page: 2

SECTION I - HEALTH HAZARD DATA (Continued)
EFFECTS OF ACUTE OVEREXPOSURE: FOR PRODUCT

EYES - CAUSES IRRITATION, REDNESS, TEARING.
 SKIN - CAN CAUSE SLIGHT IRRITATION.
 BREATHING - EXCESSIVE INHALATION OF VAPORS CAN CAUSE NASAL AND RESPIRATORY IRRITATION, CENTRAL NERVOUS SYSTEM EFFECTS INCLUDING DIZZINESS, WEAKNESS, FATIGUE, NAUSEA, HEADACHE AND POSSIBLE UNCONSCIOUSNESS, AND EVEN DEATH.
 SWALLOWING - CAN CAUSE GASTROINTESTINAL IRRITATION, NAUSEA, VOMITING, AND DIARRHEA.

FIRST AID:

IF ON SKIN: THOROUGHLY WASH EXPOSED AREA WITH SOAP AND WATER. REMOVE CONTAMINATED CLOTHING. LAUNDRY CONTAMINATED CLOTHING BEFORE RE-USE.
 IF IN EYES: FLUSH WITH LARGE AMOUNTS OF WATER, LIFTING UPPER AND LOWER LIDS OCCASIONALLY, GET MEDICAL ATTENTION.
 IF SWALLOWED: IMMEDIATELY DRINK TWO GLASSES OF WATER AND INDUCE VOMITING BY EITHER GIVING IPECAC SYRUP OR BY PLACING FINGER AT BACK OF THROAT. NEVER GIVE ANYTHING BY MOUTH TO AN UNCONSCIOUS PERSON. GET MEDICAL ATTENTION IMMEDIATELY.
 IF BREATHED: IF AFFECTED, REMOVE INDIVIDUAL TO FRESH AIR. IF BREATHING IS DIFFICULT, ADMINISTER OXYGEN. IF BREATHING HAS STOPPED GIVE ARTIFICIAL RESPIRATION. KEEP PERSON WARM, QUIET AND GET MEDICAL ATTENTION.

PRIMARY ROUTE(S) OF ENTRY:

INHALATION, SKIN CONTACT

EFFECTS OF CHRONIC OVEREXPOSURE: FOR PRODUCT

OVEREXPOSURE TO THIS MATERIAL (OR ITS COMPONENTS) HAS APPARENTLY BEEN FOUND TO CAUSE THE FOLLOWING EFFECTS IN LABORATORY ANIMALS: KIDNEY DAMAGE, EYE DAMAGE

SECTION II - REACTIVITY DATA

HAZARDOUS POLYMERIZATION: CANNOT OCCUR

STABILITY: STABLE

INCOMPATIBILITY: AVOID CONTACT WITH: STRONG OXIDIZING AGENTS., STRONG ALKALIES., STRONG MINERAL ACIDS.

SECTION III - SPILL OR LEAK PROCEDURES
STEPS TO BE TAKEN IN CASE MATERIAL IS RELEASED OR SPILLED:

SMALL SPILL: ABSORB LIQUID ON PAPER, VERMICULITE, FLOOR ABSORBENT, OR OTHER ABSORBENT MATERIAL AND TRANSFER TO HOOD.

LARGE SPILL: ELIMINATE ALL IGNITION SOURCES (FLARES, FLAMES INCLUDING PILOT LIGHTS, ELECTRICAL SPARKS). PERSONS NOT WEARING PROTECTIVE EQUIPMENT SHOULD BE EXCLUDED FROM AREA OF SPILL UNTIL CLEAN-UP HAS BEEN COMPLETED. STOP SPILL AT SOURCE, DIKE AREA OF SPILL TO PREVENT SPREADING, PUMP LIQUID TO SALVAGE TANK. REMAINING LIQUID MAY BE TAKEN UP ON SAND, CLAY, EARTH, FLOOR ABSORBENT, OR OTHER ABSORBENT MATERIAL AND SHOVELED INTO CONTAINERS.

WASTE DISPOSAL METHOD:

SMALL SPILL: DISPOSE OF IN ACCORDANCE WITH ALL LOCAL, STATE AND FEDERAL REGULATIONS.

LARGE SPILL: DISPOSE OF IN ACCORDANCE WITH ALL LOCAL, STATE AND FEDERAL REGULATIONS.

SECTION IV - PROTECTIVE EQUIPMENT TO BE USED

RESPIRATORY PROTECTION: IF WORKPLACE EXPOSURE LIMIT(S) OF PRODUCT OR ANY COMPONENT IS EXCEEDED (SEE SECTION II), A NIOSH/MSHA APPROVED AIR SUPPLIED RESPIRATOR IS ADVISED IN ABSENCE OF PROPER ENVIRONMENTAL CONTROL. OSHA REGULATIONS ALSO PERMIT OTHER NIOSH/MSHA RESPIRATORS (NEGATIVE PRESSURE TYPE) UNDER SPECIFIED CONDITIONS (SEE YOUR SAFETY EQUIPMENT SUPPLIER). ENGINEERING OR ADMINISTRATIVE CONTROLS SHOULD BE IMPLEMENTED TO REDUCE EXPOSURE.

VENTILATION: PROVIDE SUFFICIENT MECHANICAL (GENERAL AND/OR LOCAL EXHAUST) VENTILATION TO MAINTAIN EXPOSURE BELOW TLV(S).

PROTECTIVE GLOVES: WEAR RESISTANT GLOVES SUCH AS: NATURAL RUBBER, NEOPRENE, NITRILE RUBBER

EYE PROTECTION: CHEMICAL SPLASH GOGGLES IN COMPLIANCE WITH OSHA REGULATIONS ARE ADVISED; HOWEVER, OSHA REGULATIONS ALSO PERMIT OTHER TYPE SAFETY GLASSES. (CONSULT YOUR SAFETY EQUIPMENT SUPPLIER)

OTHER PROTECTIVE EQUIPMENT: TO PREVENT REPEATED OR PROLONGED SKIN CONTACT, WEAR IMPERVIOUS CLOTHING AND BOOTS.

SECTION V - SPECIAL PRECAUTIONS FOR OTHER COMMENTS

CONTAINERS OF THIS MATERIAL MAY BE HAZARDOUS WHEN EMPTIED SINCE EMPTIED CONTAINERS RETAIN PRODUCT RESIDUES (VAPOR, LIQUID, AND/OR SOLID), ALL HAZARD PRECAUTIONS GIVEN IN THE DATA SHEET MUST BE OBSERVED.

THE INFORMATION ACCUMULATED HEREIN IS BELIEVED TO BE ACCURATE BUT IS NOT WARRANTED TO BE WHETHER ORIGINATING WITH THE COMPANY OR NOT. RECIPIENTS ARE ADVISED TO CONFIRM IN ADVANCE OF NEED THAT THE INFORMATION IS CURRENT, APPLICABLE, AND SUITABLE TO THEIR CIRCUMSTANCES.

**MATERIAL SAFETY
DATA SHEET**

24-HOUR EMERGENCY TELEPHONE (606) 324-1133

DEFINITIONS

This definition page is intended for use with Material Safety Data Sheets supplied by the Ashland Chemical Company. Recipients of these data sheets should consult the OSHA Safety and Health Standards (29 CFR 1910), particularly subpart G - Occupational Health and Environmental Control, and subpart I - Personal Protective Equipment, for general guidance on control of potential Occupational Health and Safety Hazards.

**SECTION I
PRODUCT IDENTIFICATION**

GENERAL OR GENERIC ID: Chemical family or product description.

DOT HAZARD CLASSIFICATION: Product meets DOT criteria for hazards listed.

**SECTION II
COMPONENTS**

Components are listed in this section if they present a physical or health hazard and are present at or above 1% in the mixture. If a component is identified as a CARCINOGEN by NTP, IARC or OSHA as of the date on the MSDS, it will be listed and footnoted in this section when present at or above 0.1% in the product. Negative conclusions concerning carcinogenicity are not reported. Additional health information may be found in Section V. Components subject to the reporting requirements of Section 313 of SARA Title III are identified in the footnotes in this section, along with typical percentages. Other components may be listed if deemed appropriate.

Exposure recommendations are for components. OSHA Permissible Exposure Limits (PELs) and American Conference of Governmental Industrial Hygienists (ACGIH) Threshold Limit Values (TLVs) appear on the line with the component identification. Other recommendations appear as footnotes.

**SECTION III
PHYSICAL DATA**

BOILING POINT: Of product if known. The lowest value of the components is listed for mixtures.

VAPOR PRESSURE: Of product if known. The highest value of the components is listed for mixtures.

SPECIFIC VAPOR DENSITY: Compared to AIR = 1. If Specific Vapor Density of product is not known, the value is expressed as lighter or heavier than air.

SPECIFIC GRAVITY: Compared to WATER = 1. If Specific Gravity of product is not known, the value is expressed as less than or greater than water.

pH: If applicable.

PERCENT VOLATILES: Percentage of material with initial boiling point below 425 degrees Fahrenheit.

EVAPORATION RATE: Indicated as faster or slower than ETHYL ETHER, unless otherwise stated.

**SECTION IV
FIRE AND EXPLOSION DATA**

FLASH POINT: Method identified.

EXPLOSION LIMITS: For product if known. The lowest value of the components is listed for mixtures.

HAZARDOUS DECOMPOSITION PRODUCTS: Known or expected hazardous products resulting from heating, burning or other reactions.

SECTION IV (cont.)

EXTINGUISHING MEDIA: Following National Fire Protection Association criteria.

FIREFIGHTING PROCEDURES: Minimum equipment to protect firefighters from toxic products of vaporization, combustion or decomposition in fire situations. Other firefighting hazards may also be indicated.

SPECIAL FIRE AND EXPLOSION HAZARDS: States hazards not covered by other sections.

NFPA CODES: Hazard ratings assigned by the National Fire Protection Association.

**SECTION V
HEALTH HAZARD DATA**

PERMISSIBLE EXPOSURE LIMIT: For product.

THRESHOLD LIMIT VALUE: For product.

EFFECTS OF ACUTE OVEREXPOSURE: Potential local and systemic effects due to single or short term overexposure to the eyes and skin or through inhalation or ingestion.

EFFECTS OF CHRONIC OVEREXPOSURE: Potential local and systemic effects due to repeated or long term overexposure to the eyes and skin or through inhalation or ingestion.

FIRST AID: Procedures to be followed when dealing with accidental overexposure.

PRIMARY ROUTE OF ENTRY: Based on properties and expected use.

**SECTION VI
REACTIVITY DATA**

HAZARDOUS POLYMERIZATION: Conditions to avoid to prevent hazardous polymerization resulting in a large release of energy.

STABILITY: Conditions to avoid to prevent hazardous or violent decomposition.

INCOMPATIBILITY: Materials and conditions to avoid to prevent hazardous reactions.

**SECTION VII
SPILL OR LEAK PROCEDURES**

Reasonable precautions to be taken and methods of containment, clean-up and disposal. Consult federal, state and local regulations for accepted procedures and any reporting or notification requirements.

**SECTION VIII
PROTECTIVE EQUIPMENT TO BE USED**

Protective equipment which may be needed when handling the product.

**SECTION IX
SPECIAL PRECAUTIONS OR OTHER COMMENTS**

Covers any relevant points not previously mentioned.

ADDITIONAL COMMENTS

Containers should be either reconditioned by CERTIFIED firms or properly disposed of by APPROVED firms. Disposal of containers should be in accordance with applicable laws and regulations. "EMPTY" drums should not be given to individuals. Serious accidents have resulted from the misuse of "EMPTIED" containers (drums, pails, etc.). Refer to Sections IV and IX.

MATERIAL SAFETY DATA SHEET

N.F. 2 A

TRADE NAME: CON-BOND 1736 N/F *Cement*

SECTION I

MANUFACTURER'S NAME Columbia Cement Co., Inc.	EMERGENCY TELEPHONE NO. 516 623-6000
ADDRESS (Number, Street, City, State, and ZIP Code) 159 Halse Ave. Freeport, New York 11520	
Prepared by: R.J. Dawnkaski	Date: 6/5/85
CHEMICAL FAMILY CHLOROPRENE RUBBER AND SYNTHETIC RESIN SOLUTION IN CHLORINATED ORGANIC SOLVENT	

SECTION II - HAZARDOUS INGREDIENTS

INGREDIENT	% WEIGHT	C. A. S. NUMBER	PEL (PPM) OSHA	TLV (PPM) ACGIH
1,1,1 - TRICHLOROETHANE	60	71-55-6	350	350
METHYLENE CHLORIDE	30	75-09-2	500	100

SECTION III - PHYSICAL DATA

BOILING POINT (°F.)	104°-165°F	SPECIFIC GRAVITY (H ₂ O=1)	1.26
VAPOR PRESSURE (mm Hg.) @ 20°C	210	PERCENT VOLATILE BY weight (%)	90
VAPOR DENSITY (AIR=1)	3.8	EVAPORATION RATE (n-butyl acetate=1) 1,1,1 Trichloroethane	6
SOLUBILITY IN WATER	Negligible	Methylene Chloride	14.5
APPEARANCE AND ODOR Amber thin syrup; dyed red or green; slightly sweetish odor.			

SECTION IV - FIRE AND EXPLOSION HAZARD DATA

FLASH POINT (METHOD USED)	None - TOC, TCC, COC	FLAMMABLE LIMITS In Air	LEL 7.5	UEL 22
EXTINGUISHING MEDIA	WATER FOG			
SPECIAL FIRE FIGHTING PROCEDURES	Self contained breathing apparatus with a full face piece operated in pressure-demand or other positive pressure mode. Avoid breathing vapors or fumes.			
UNUSUAL FIRE AND EXPLOSION HAZARDS	This solvent has no flash point or fire point as determined by standard laboratory methods. It does, however, have a flammable range when high concentrations of vapor are mixed in air. For this reason, ignition sources should not be present when cleaning closed tanks or in highly confined, unventilated areas.			

SECTION V - HEALTH HAZARD DATA

PEL - Permissible exposure level (OSHA) 29 CFR 1910.1000 Table Z-1 and Z-2
 TLV - Threshold limit value (ACGIH) ACGIH (1984-85)

See page (3) for acute and chronic health effects and emergency and first aid procedures.

SECTION VI - REACTIVITY DATA

STABILITY	UNSTABLE		CONDITIONS TO AVOID Avoid open flames, welding arcs or other high temperature sources which induce thermal decomposition.
	STABLE	X	
INCOMPATIBILITY (Materials to avoid): Water-long term contact can deplete stabilizers followed by slow hydrolysis producing corrosive acid. Avoid prolonged contact with or storage in aluminum or its alloys. Metallic aluminum and zinc powders should be avoided.			
HAZARDOUS POLYMERIZATION	MAY OCCUR		CONDITIONS TO AVOID None
	WILL NOT OCCUR	X	
HAZARDOUS DECOMPOSITION PRODUCTS: Fumes, smoke, CO, etc in case of incomplete combustion in air. Hydrogen chloride and very small amounts of phosgene and chlorine from solvent.			

SECTION VII - SPILL OR LEAK PROCEDURES

STEPS TO BE TAKEN IN CASE MATERIAL IS RELEASED OR SPILLED: Keep people away. Recover free liquid. Add absorbent (sand, earth, sawdust, etc.) to spill area. Avoid breathing vapors. Ventilate confined spaces. Open all windows and doors. Shovel into containers for disposal. Keep petroleum products out of sewers and water courses by diking and impounding. Advise authorities if product has entered or may enter sewers.

WASTE DISPOSAL METHOD: Small spill - Allow volatile portion to evaporate in well ventilated area. Dispose of remaining material in accordance with applicable regulations.
 Large spill - Dispose of material or contaminated absorbent by incineration or deposition in approved landfill in accordance with local, state or federal regulations.

SECTION VIII - SPECIAL PROTECTION INFORMATION

RESPIRATORY PROTECTION (Specify type) Use NIOSH approved hydrocarbon vapor cannister or supplied air respiratory protection in confined or enclosed spaces or where vapor concentration exceeds TLV or PEL.		
VENTILATION	LOCAL EXHAUST Sufficient to maintain exposure below TLV or PEL	SPECIAL
	MECHANICAL (General)	OTHER
PROTECTIVE GLOVES: Use chemical resistant gloves. EYE PROTECTION: Use splash goggles or face shield if needed to avoid repeated or prolonged skin contact. when eye contact may occur.		
OTHER PROTECTIVE EQUIPMENT: Use chemical resistant apron or other clothing if needed to avoid repeated or prolonged skin contact.		

SECTION IX - SPECIAL PRECAUTIONS

PRECAUTIONS TO BE TAKEN IN HANDLING AND STORAGE: Handle with reasonable care. Avoid breathing vapors. Store in a cool, dry place. Keep container closed when not in use. Aluminum is not an acceptable material of construction for pumps, mixers, fittings or storage tanks for use with this product. Metallic aluminum and zinc powders should be avoided.

OTHER PRECAUTIONS: Vapors of this product are heavier than air and will collect in low areas such as pits, degreasers, storage tanks and other confined areas. Do not weld or cut where vapors are present.

All hazard precautions given in data sheet must be observed.

MATERIAL SAFETY DATA SHEETN/F 2 A
N/F 2 BSECTION X - ACUTE EFFECTS OF OVEREXPOSURE

- Inhalation** - Minimal anesthetic or narcotic effects may be seen in the range of 500-1000 ppm. Progressively higher levels over 1000 ppm may cause dizziness, drunkenness; concentrations in excess of 10,000 ppm can cause unconsciousness and death. These high levels may also cause cardiac arrhythmias (irregular heartbeats). Carboxyhemoglobin levels may be elevated.
- Ingestion** - Can cause gastrointestinal irritation, nausea, vomiting and diarrhea; aspiration of material into the lungs can cause chemical pneumonitis which can be fatal.
- Eye Contact** - Can cause severe irritation, redness, tearing, blurred vision. Slight transient corneal injury possible. Should heal in a few days.
- Skin Contact** - Prolonged or repeated contact can cause moderate irritation, defatting, dermatitis. Can be absorbed through the skin but not likely to be absorbed in harmful amounts.

SECTION XI - CHRONIC EFFECTS OF OVEREXPOSURE

Overexposure to components has apparently been found to cause the following effects in laboratory animals: Kidney damage, liver abnormalities.

SECTION XII - EMERGENCY AND FIRST AID PROCEDURES

- Inhalation** - If affected, remove individual to fresh air. If breathing is difficult, administer oxygen. If breathing has stopped, give artificial respiration. Keep person warm, quiet and get medical attention.
- Ingestion** - Do not induce vomiting. Keep person warm, quiet and get medical attention. Aspiration of material into the lungs due to vomiting can cause chemical pneumonitis which can be fatal.
- Eye Contact** - Flush with large amounts of water for at least 15 minutes, lifting upper and lower lids occasionally. Get medical attention.
- Skin Contact** - Thoroughly wash exposed area with soap and water. Remove contaminated clothing. Launder contaminated clothing before re-use.

NOTE TO PHYSICIAN: **Eyes:** May cause irritation. Stain for evidence of corneal injury. If cornea is burned, instill antibiotic steroid preparation frequently. Consult ophthalmologist.

Skin: May cause irritation, chronic exposure may cause defatting type of dermatitis. If rash is present, treat as any contact dermatitis.

Respiratory: Anesthetic or narcotic effect may occur. Administer oxygen if available.

Oral: May cause chemical pneumonia if aspirated into lungs. Danger of chemical pneumonia must be weighed against toxicity when considering emptying the stomach. If lavage is performed, suggest endotracheal or esophagoscopy control.

Systemic: May cause increase in carboxyhemoglobin level. May increase myocardial irritability. Avoid epinephrine or similar acting drugs if at all possible. Consult standard literature. No specific antidote. Treatment based on the sound judgment of the physician and the individual reactions of the patient.

**MATERIAL SAFETY DATA SHEET
FOR COATINGS, RESINS AND RELATED MATERIALS**

NAUTICAL COATINGS INC.
P.O. BOX 310305
TAMPA, FLORIDA 33680

DATE OF PREPARATION: 1/4/88 EMERGENCY TELEPHONE NO.: 813-536-3789
SIGNATURE OF PREPARER: *[Signature]* INFORMATION TELEPHONE NO.: 813-536-3789

SECTION I - PRODUCT IDENTIFICATION

PRODUCT NUMBER: 3400 SERIES PRODUCT NAME: SEA HAWK CUKOTE ANTI-FOULING COATING
PRODUCT CLASS: CUPROUS OXIDE PAINT

SECTION II - HAZARDOUS INGREDIENTS

INGREDIENT	PERCENT	OCCUPATIONAL EXPOSURE LIMITS		VAPOR PRESSURE
		TLV	PEL	
AROMATIC HYDROCARBON	16.2	35		3mm@20°C
XYLENE	6.3	100		10mm@28°C

SECTION III - PHYSICAL DATA

BOILING RANGE VAPOR DENSITY HEAVIER LIGHTER THAN AIR
EVAPORATION RATE FASTER SLOWER THAN ETHER % VOLATILE WT. 22.3VT/GAL 17.8

SECTION IV - FIRE AND EXPLOSION HAZARD DATA

FLAMMABILITY CLASSIFICATION OSHA 1C FLASH POINT 84°F LEL 0.7
DOT FLAMMABLE LIQUID

EXTINGUISHING MEDIA:

FOAM ALCOHOL CO2 WATER FOG OTHER

UNUSUAL FIRE AND EXPLOSION HAZARDS: KEEP CONTAINER TIGHTLY CLOSED. AVOID HEAT, OPEN FLAMES, STATIC ELECTRICITY, ELECTRICAL EQUIPMENT AND SPARKS. CLOSED CONTAINERS MAY EXPLODE WHEN EXPOSED TO EXTREME HEAT. APPLICATION TO HOT SURFACES REQUIRES SPECIAL PRECAUTIONS. DURING EMERGENCY SITUATION, OVER-EXPOSURE TO DECOMPOSITION PRODUCTS MAY CAUSE A HEALTH HAZARD WITH NO SYMPTOMS IMMEDIATELY APPARENT. OBTAIN MEDICAL ATTENTION.

SPECIAL FIRE FIGHTING PROCEDURES: FULL PROTECTIVE EQUIPMENT INCLUDING SELF-CONTAINED BREATHING APPARATUS SHOULD BE USED. - WATER SPRAY MAY BE INEFFECTIVE. IF WATER IS USED, FOG NOZZLES ARE PREFERABLE WATER MAY BE USED TO COOL CLOSED CONTAINERS TO PREVENT PRESSURE BUILDUP.

SECTION V - HEALTH HAZARD DATA

PRIMARY ROUTE (S) OF ENTRY: DERMAL INHALATION INGESTION

EMERGENCY AND FIRST AID PROCEDURE

EYE CONTACT	If this product comes in contact with the eyes, flush with large quantities of water for at least 15 minutes and seek immediate medical attention.
SKIN CONTACT	If this product comes in contact with the skin, wash with soap and large quantities of water and seek medical attention if irritation from contact persists.
INHALATION	If breathing difficulties, headaches, dizziness, or lightheadedness occur when working in areas with high vapor concentrations, victim should seek air free of vapors. If victim experiences continued breathing difficulties, administer oxygen until medical assistance can be rendered. If breathing stops, begin artificial respiration and seek medical attention.
INGESTION	DRINK PROMPTLY A LARGE QUANTITY OF MILK, EGG WHITES, OR GELATIN SOLUTION OR IF THESE ARE NOT AVAILABLE DRINK LARGE QUANTITIES OF WATER. GET MEDICAL ATTENTION.

PHYSIOLOGICAL EFFECTS AND HEALTH INFORMATION

EYE EFFECTS	THIS PRODUCT MAY BE AN EYE IRRITANT. TEARING AND REDNESS MAY OCCUR.
SKIN EFFECTS	THIS PRODUCT MAY CAUSE SKIN IRRITATION.
SYSTEMIC EFFECTS	<p>VARIOUS STUDIES HAVE SHOWN A POSSIBLE ASSOCIATION WITH EXPOSURE TO THIS PRODUCT AND THE FOLLOWING:</p> <ul style="list-style-type: none"> Respiratory tract irritation. Central nervous system depression in high concentrations. Nausea and vomiting. <p>NOTE: REPORTS HAVE ASSOCIATED REPEATED AND PROLONGED OVER-EXPOSURE TO SOLVENTS WITH PERMANENT BRAIN AND NERVOUS SYSTEM DAMAGE. INTENTIONAL MISUSE BY DELIBERATELY CONCENTRATING AND INHALING THE CONTENTS MAY BE HARMFUL OR FATAL.</p>

SECTION VI - REACTIVITY DATA

STABILITY

 UNSTABLE STABLE

HAZARDOUS POLYMERIZATION

 MAY OCCUR WILL NOT OCCUR

HAZARDOUS DECOMPOSITION PRODUCTS:

CONDITIONS TO AVOID: Heat, open flames, electrical and static discharges.

INCOMPATIBILITY (MATERIALS TO AVOID): Strong Acids, Alkalies and Oxidizers.

SECTION VII - SPILL OR LEAK PROCEDURES

STEPS TO BE TAKEN IN CASE MATERIAL IS RELEASED OR SPILLED:

VENTILATE AREA. REMOVE ALL POSSIBLE SOURCES OF IGNITION. AVOID PROLONGED BREATHING OF VAPORS, CONFINED SPILL WITH INERT ABSORBENT AND CLEAN UP WITH SPARK-PROOF TOOLS. WEAR PROTECTIVE EQUIPMENT DURING CLEAN-UP.

WASTE DISPOSAL:

dispose of in an approved chemical dumpsite in accordance with Local, State and Federal Regulations by approved contractors.

SECTION VIII - SAFE HANDLING AND USE INFORMATION

RESPIRATORY PROTECTION: Use NIOSH/MSHA approved respirator to remove a combination or particles, gas & vapor. Use air line if necessary.

VENTILATION: Use adequate ventilation in volume and pattern to keep LEL and TLV's in Section II below recommended level to produce explosion or fire. General mechanical ventilation should comply with OSHA 1910.94.

PROTECTIVE GLOVES: Use rubber gloves.

EYE PROTECTION: Safety glasses or goggles with splash guards or side shields.

OTHER PROTECTIVE EQUIPMENT: Prevent prolonged skin contact to contaminated clothing.

SECTION IX - SPECIAL PRECAUTIONS

PRECAUTIONS TO BE TAKEN IN HANDLING AND STORING: Store in a cool dry area away from sources of ignition. When storing large quantities, store in building designed and protected against flammable liquids. Use static lines when mixing and transferring material. Do not allow material to free fall more than five (5) inches.

OTHER PRECAUTIONS: "FOR ^{commercial} USE ONLY" Do not take internally. If ingested, Consult a physician. Do not flame cut, weld, or braze on coated metal without a NIOSH/MSHA approved respirator.

The information contained herein is based on technical data which we believe to be reliable, however, since the conditions under which this information may be applied are beyond our control, we can assume no liability for results of its application. This information should be used only by persons having sufficient technical skill to make informed judgements regarding its application.

EXHIBIT "A" - PART 3

POTENTIAL EMISSIONS

STYRENE:

$$(27.7 \text{ \#/hr})(52 \text{ wk/yr} \times 7 \text{ day/wk} \times 24 \text{ hr/day}) = 241,638 \text{ \#/yr} = 120.8 \text{ T/yr}$$

METHYL
METHACRALATE:

$$(6.3 \text{ \#/hr})(52 \text{ wk/yr} \times 7 \text{ day/wk} \times 24 \text{ hr/day}) = 54,906 \text{ \#/yr} = 27.5 \text{ T/yr}$$

ACETONE: **

$$(38.4 \text{ \#/hr})(52 \text{ wk/yr} \times 7 \text{ day/wk} \times 24 \text{ hr/day}) = 335,462 \text{ \#/yr} = 167.7 \text{ T/yr}$$

1,1,1-TRICHLOROETHANE:

$$(1.51 \text{ \#/hr})(52 \text{ wk/yr} \times 7 \text{ day/wk} \times 24 \text{ hr/day}) = 13,209 \text{ \#/yr} = 6.6 \text{ T/yr}$$

METHYLENE CHLORIDE:

$$(0.76 \text{ \#/hr})(52 \text{ wk/yr} \times 7 \text{ day/wk} \times 24 \text{ hr/day}) = 6,640 \text{ \#/yr} = 3.3 \text{ T/yr}$$

AROMATIC HYDROCARBON:

$$(3.56 \text{ \#/hr})(52 \text{ wk/yr} \times 7 \text{ day/wk} \times 24 \text{ hr/day}) = 31,100 \text{ \#/yr} = 15.55 \text{ T/yr}$$

XYLENE:

$$(1.38 \text{ \#/hr})(52 \text{ wk/yr} \times 7 \text{ day/wk} \times 24 \text{ hr/day}) = 12,056 \text{ \#/yr} = 6.03 \text{ T/yr}$$

** In September, Rez-Away was introduced to the Merritt Island Facility. Now the average use of acetone has been decreased to 600 gallons per week with 275 gallons sent to be recycled, giving a net usage of acetone of 325 gallons per week. Therefore:

$$(325 \text{ gal/wk}) \times (6.61 \text{ \#/gal}) = 2,148.25 \text{ \#/wk} \times 52 \text{ wks/yr} = 111,709 \text{ \#/yr} \\ = 55.85 \text{ T/yr}$$

EXHIBIT "B"

Sea Ray Boats at the Merritt Island Facility is in the business of manufacturing fiberglass pleasure boats.

The process is generally described as follows:

Step 1. Gel coat (the exterior colors) are sprayed into a mold by an airless method. Gel Coat is described in the attached Material Safety Data Sheets titled Exhibit A.

Step 2. Structural resin and fiberglass is again sprayed by an airless method into the mold over the Gel Coat and wooden and foam parts are added for rigidity. Resin is described in the attached Material Safety Data Sheets titled Exhibit A.

Step 3. After the lamination (resin applications) process the hull and deck parts plus any miscellaneous small parts are extracted from their molds and are trimmed of excess or overspray. (Molds are cleaned, waxed and returned to Step 1).

Step 4. Glue is utilized in the preparation of upholstered parts, which are also used in the final assembly process.

Step 5. The boat assembly process utilizes the fiberglass parts, the exposed wooden parts and other materials and parts which come to the site in a ready to use condition (i.e. they are not manufactured on site).

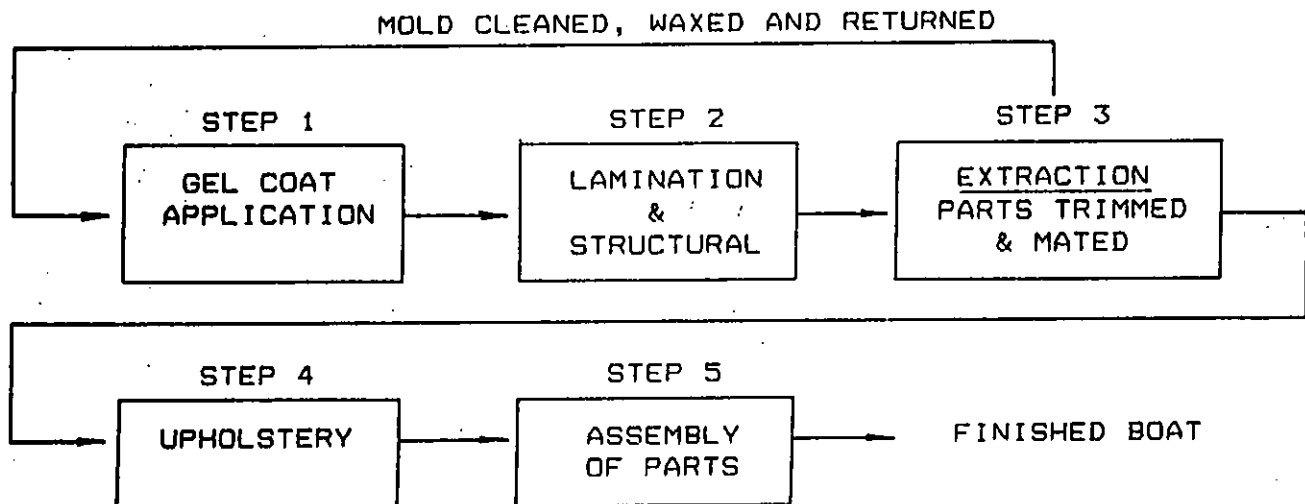

CHEMISTRY

Polyester resin is a chemical chain containing organic acids and alcohols with an ester linkage (hence the name, polyester).

Styrene is the most commonly used crosslinking agent that connects the polyester chains and creates a polyester resin which is liquid and flexible for the fabrication of parts.

Styrene, as a crosslinking agent, reacts with the available bond sites on the polyester chain, usually the unsaturated organic acid.

When the resin arrives at the plant it is in a liquid form: a polyester thinned with about 50% styrene monomer and mixed with inhibitors to prevent a spontaneous cross-linking reaction.

Catalysts, promoters and temperature control the rate of cross-linking or reaction. Methyl Ethyl Ketone Peroxide is the catalyst used and is normally a 1% addition.

Acetone is used as a solvent to clean equipment after application of the resin.

Per phone conversation on 3-27-89 with chemist Ron Pastorino of Witco, U. S. Peroxygen Products, Argus Division, we were advised that the MEKP is approximately 40% of the product and that almost all components are totally consumed. Much less than 3% is volatilized and that the 3% is mainly made up of water and trace MEK and if any is MEKP it was a negligible amount.

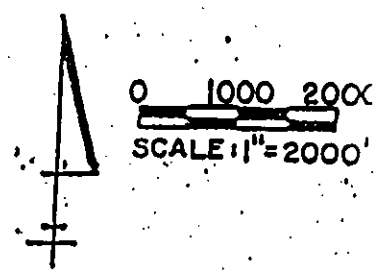
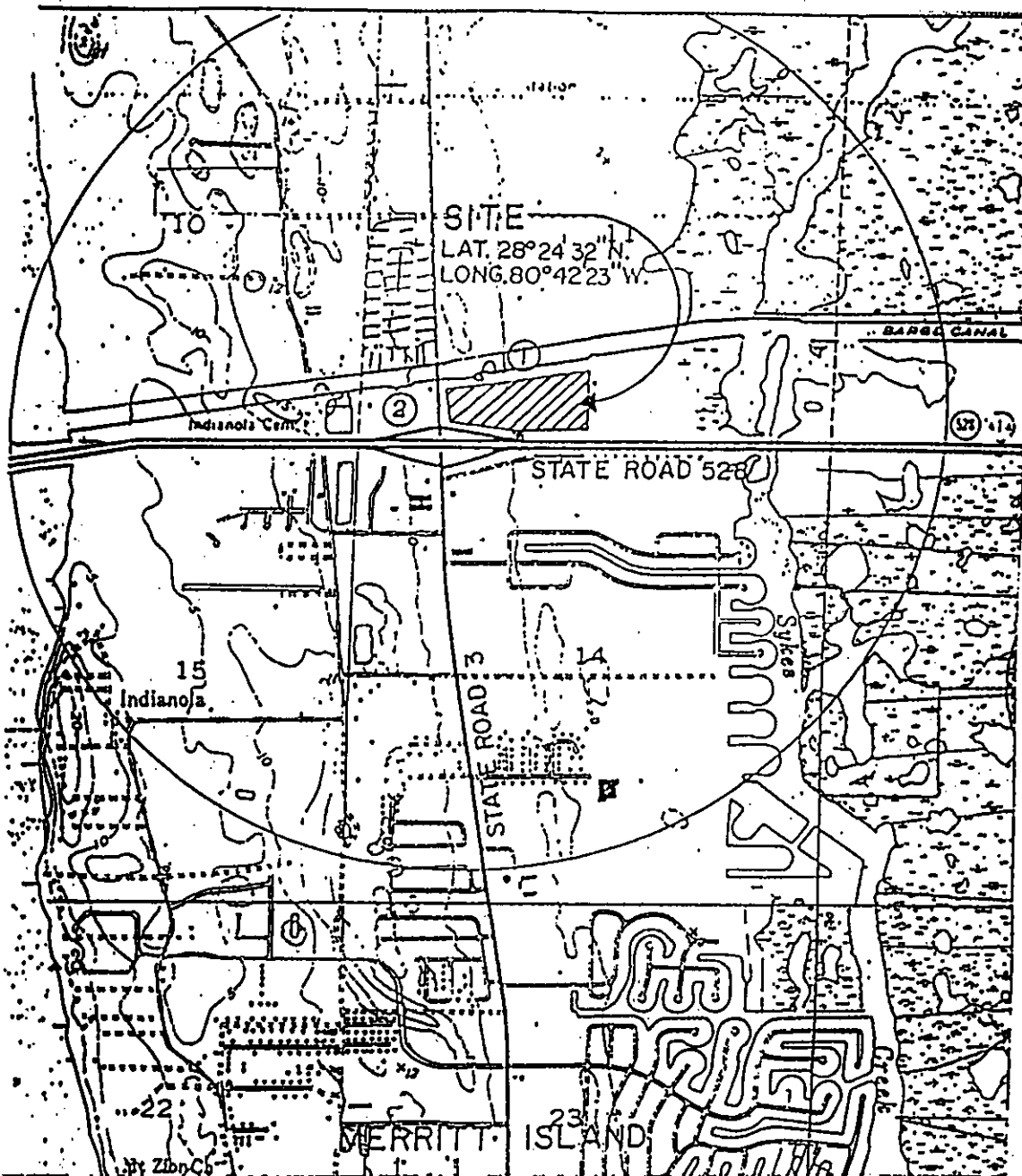

ADJACENT PROPERTY OWNERS
 CANAVERAL PORT AUTHORITY
 P.O. BOX 267
 CAPE CANAVERAL, FLA.
 32920
 TINGLY'S FISH CAMP
 STATE ROAD 3
 MERRITT ISLAND, FLA.
 32952

VICINITY MAP

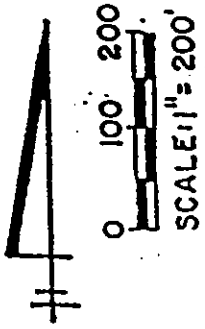

SITE PLAN

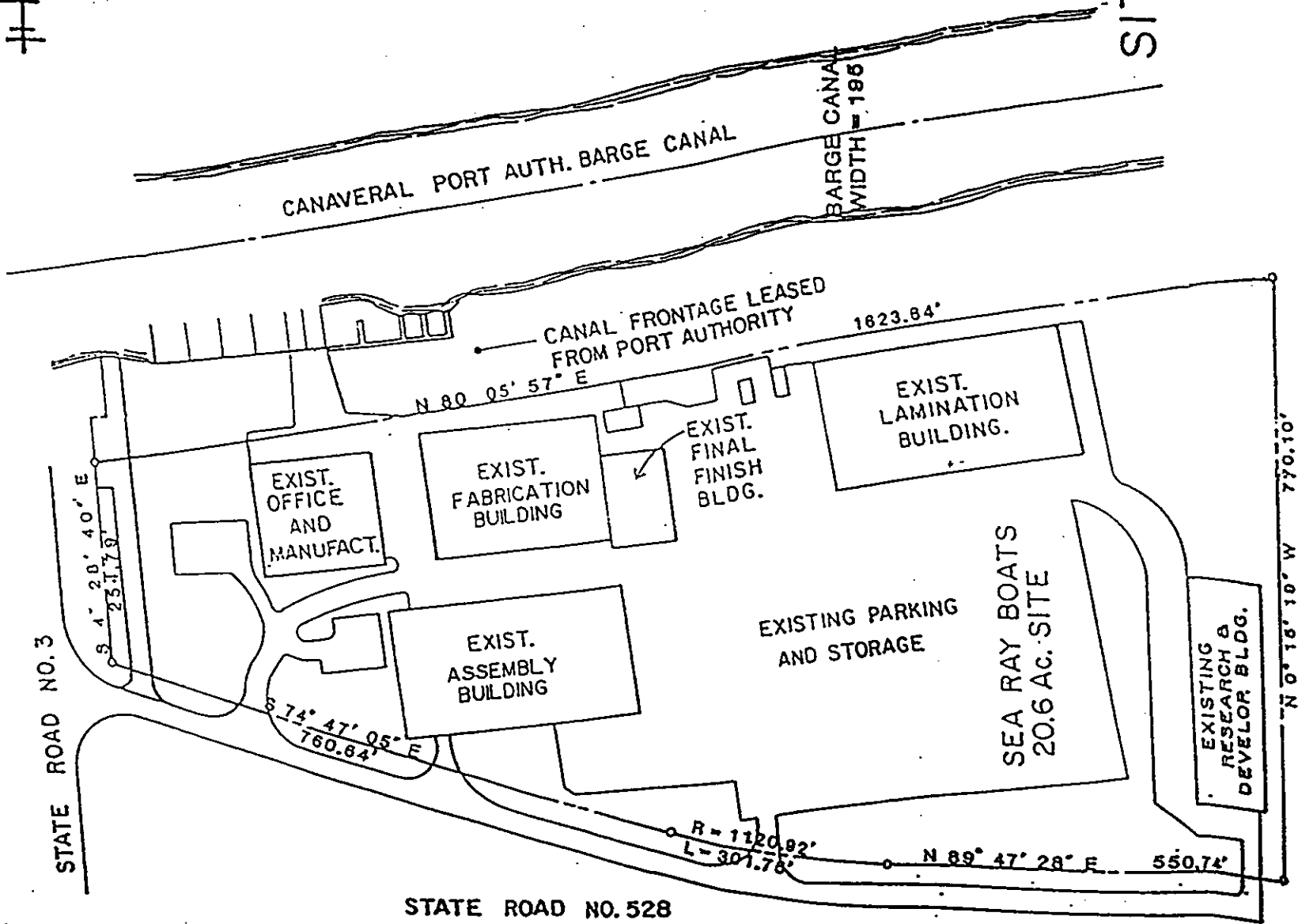
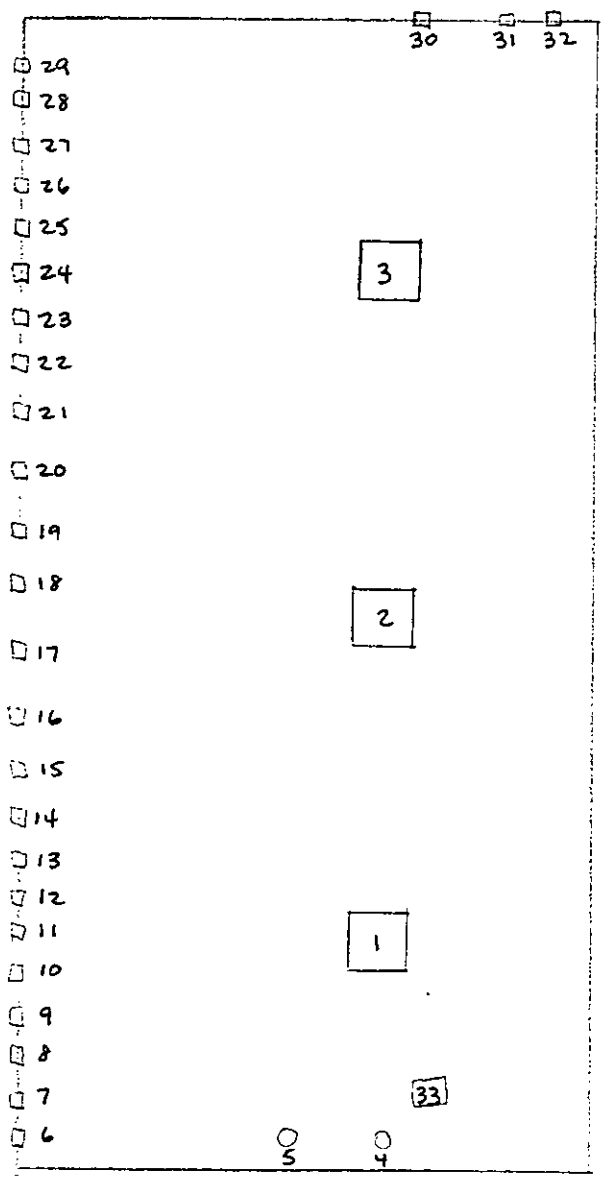
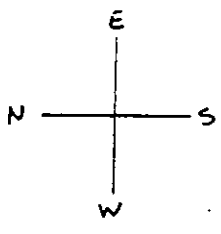

EXHIBIT "D" - PART 2

LAMINATION



LAMINATION

DESCRIPTION	H. P.	FAN	MANUFACTURE
1. AIR HANDLERS DFT2250AJC221A4G4GA41130101	25		TRANE
2. AIR HANDLERS DFT2250ADA221A4G4GA11130101	25		TRANE
3. AIR HANDLERS DFT2250AFC221A4G4GA11130101	25		
4. VENTILATION		30"	DOMEX PENN
5. VENTILATION		30"	DOMEX PENN
6. FAN	3	40"	
7. FAN	3	40"	
8. FAN	2	40"	
9. FAN	2	40"	
10. FAN	2	40"	
11. FAN	2	40"	
12. FAN	2	40"	
13. FAN	2	40"	
14. FAN	2	40"	
15. FAN	2	40"	
16. FAN	2	40"	
17. FAN	2	40"	
18. FAN	2	40"	
19. FAN	2	40"	
20. FAN	2	40"	
21. FAN	2	40"	
22. FAN	2	40"	
23. FAN	2	40"	
24. FAN	2	40"	
25. FAN	2	32"	
26. FAN	2	32"	
27. FAN	2	32"	
28. FAN	2	32"	
29. FAN	2	40"	
30. FAN	2	32"	
31. FAN	2	32"	
32. FAN	2	32"	
33. SMOKE EATER MODEL F70			HONEYWELL

Since The Trane Company has a policy of continuous product improvement, it reserves the right to change specifications and design without notice.

JANUARY, 1972

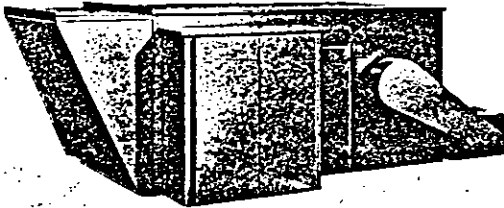

DIRECT FIRED TORRIVENTS

MODELS 1150 THROUGH 2300

OPERATING THE UNIT

Three adjustable temperature controls (1THS, 2THS, 3THS) are provided on the unit along with "Start-Stop" operating switch (1RS) and three pilot lights (1LT, 3LT, 5LT) on the unit control box. The power box, which may be in "Location 1" or "Location 2" on the unit, contains an "On-Off" disconnect switch (DS). See Figure 1.

NOTE: The component designation given in parenthesis are as listed on the unit wiring diagrams.

A remote control box installed in the occupied space, includes a "Start-Stop" operating switch (2RS), temperature control (TC) and operating pilot lights (2LT, 4LT, 6LT).

Pilot lights on the unit control box and/or remote control box indicate conditions of unit operation. White pilot light "Motor On" indicates that the unit motor and fan are operating, and the outlet damper, if used, has opened. Amber pilot light "Burner On" will light with firing of the burner. In the event of a flame failure when burner operation is required, the red pilot light "Alarm" will glow.

With the disconnect switch closed and the unit temperature controls properly set, unit operation is automatic after pushing the "Start-Stop" operating switch to the "Start" position.

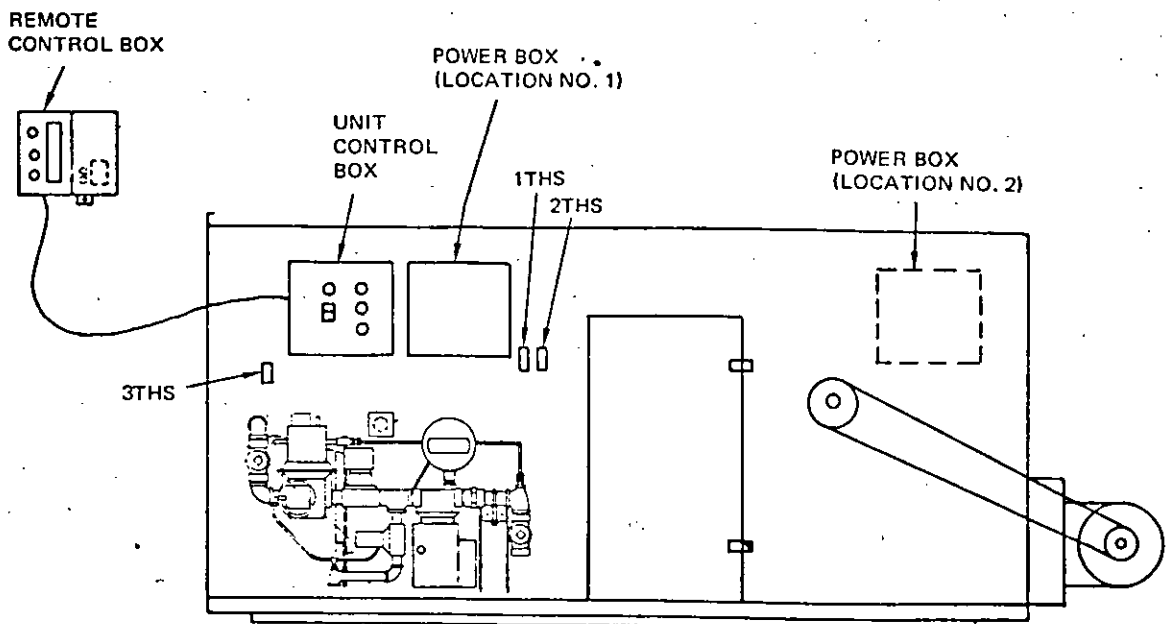

FIGURE 1 - Unit Control Boxes

Donald Wolf

DIRECT FIRED TORRIVENT

DATE SHIPPED	BILL OF LADING NO	INVOICE DATE	ORDER INVOICE NO BH3-C547
TERMS 30 DAYS NET	FOB NET 30	CLARKSVILLE II FA	NET INVOICE COPY
MARE PACKAGES			NOTIFY H.I. AIR COND AT 305-452-8711 24HRS. BEFORE DELIVERY
SHIP VIA TRUCK	MERRITT ISLAND AIR COND. INC. SEA RAY BOATS 2700 N. COURTENAY PKWY MERRITT ISLAND FLORIDA		
(INCLUDE ZIP CODE)			(INCLUDE ZIP CODE)

VISLAY & CANTELOU

DOUG STONE

SEA RAY BOATS

ORDER DATE 6/22/76	CUSTOMER ORDER NUMBER 76622C	ACCOUNT NUMBER H3-16-1488-2
-----------------------	---------------------------------	--------------------------------

S
O
I
D
O

HERRITT ISLAND AIR COND. INC.
625 CYPRESS ST.
MERRITT ISLAND FLORIDA

TAG MU-1	DFT 039	SERIAL NO. B76F02392	SUB DRWG.
ITEM	QTY	TYPE NO. 3900	PRICING

MODEL NUMBER 2250	1	2	3	4	5	6	7	8	9	10	11	12	13	14	15	16	17	18
DFT	A	2	2	1	A	4	G	4	G	A	I	I	I	3	0	I	0	I

SINGLE GAS SUPPLY SERIES 12 MODULATING SYSTEM

VERTICAL FAN DISCHARGE ARRANGEMENT

WITH OUTLET DAMPER

STANDARD VALVE TRAIN 1 1/4" INSURANCE AGENCY APPROVAL REQUIRED

3,300,000 MAX. BTUH INPUT BURNER FM FIA NONE

L.P. GAS AT 2# AVAILABLE GAS PRESSURE GAS AT AVAILABLE GAS PRESSURE

39,500 SCFM AT 1.00 INCHES TOTAL STATIC PRESSURE

20 BHP AND 565 FAN RPM

3,300,000 INPUT 71 F AIR TEMPERATURE RISE (120 F MAX)

20 H.P. MOTOR 70070004 MOTOR BY OTHERS DRIVE BY OTHERS

WITH MOTOR 460/60/3 ELEC CHAR. TYPE odp

WITH POWER BOX ORDER NO2233-8

WITH DRIVE RATED AT 1.2 MHP

565 RPM

WITH FILTER BOX WITH THROWAWAY FILTERS

WITH VALVE TRAIN ENCLOSURE

WITH MOTOR COVER

WITH INLET HOOD WITH BIRD SCREEN

ORDERED ON ROOF CURB BH3-C547B

WITH LIFTING BRACKETS

WITHOUT ROOM THERMOSTAT

SHIP ACCESSORIES ASSEMBLED (1150-1300 ONLY) YES NO

BASIC UNIT
PERFORMANCE
MOTOR & DRIVE
ACCESSORIES
SPECIAL INSTRUCTIONS

ENTERED 7/6/76 sj	SHIPMENT WANTED 8/20/76 <input checked="" type="checkbox"/> OR SOONER <input type="checkbox"/> SPECIFIED DATE	<input type="checkbox"/> HOLD FOR APPROVAL 6 NO OF PRINTS	SPECS OR	PPD TRANSPORTATION	SPA NO.	MUL
ORDER CLASS A 2D 1 C	JOB NO	CREDIT AUTHOR	TAX STATUS	TAX CODE	TAX AMOUNT	SALES ORDER NO BH3-C54
OFFICE SALES MEN & BAIL	ORLANDO MATTHEWS H3-E08 100%					
BILLING <input type="checkbox"/> MONTHLY <input type="checkbox"/> QUARTERLY <input type="checkbox"/> YEARLY	NO	P	S			SHEET 1 OF

DIRECT FIRED MAKE-UP AIR UNIT

TAG:

S.O. No. 16377

CUSTOMER P.O. NO.	REPRESENTATIVE
Appliance	To Follow
CITY	STATE
Merrit Island Fla.	Michigan Air Products
APPROVING AUTHORITY	

PLP ORDER NO. 3/11074
 REZ CODE NO. D40119

MAT-267

GENERAL SPECIFICATIONS

ITEM	QTY	MODEL NO.	LIST PRICE
1	1	CT2746 F4	
<input checked="" type="checkbox"/> End <input type="checkbox"/> Down Discharge <input type="checkbox"/> Indoor <input checked="" type="checkbox"/> Outdoor Application			

OPERATING DATA (See Reverse Side for Symbols)

POWER (3-wire) 208/3/60 230/3/60 460/3/60 375/3/60 Other

BLOWER SECTION
 Fan 40 000 CFM .50 ESP TSP 35 Elev. RPM
 Qty 2-27" Diameter DWD Forward Curved Backward Inclined Wheels
 Motor 20 HP Open (Standard) TEFC Two Speed 1800/900 RPM

BURNER
 Gas Nat. LP 2500 BTU/Hr. 1" Allow Capacities are at Elevation Shown.
 Pressure (27.7" = 1 Lb.) 18.0 MBH Input 44 of Temperature Rise 17 x 128
 496

OPTIONAL ACCESSORIES

GAS BURNER - FIA and/or FM Controls With Approval.
 One Step (1 to 5 Lbs.) Two Step (1 to 15 Lbs.) Remote High Pressure Regulation
 High Gas Pressure Safety Switch (Std. on FIA - FM with Input Over 400 MBH)
 Low Gas Pressure Safety Switch (Std. on FIA - FM with Input Over 400 MBH)
 Prepurge Cycle
 Eclipse Forward Draft Burner
 Maxon "Pro-Max" Burner
 Second Gas Valve - Motorized
 Second Gas Valve - Solenoid

ELECTRICAL - P.L.C. Controls
 Control Transformer 220-440/115 Volt
 Overriding/Modulating Room Thermostat with Discharge High Limit Controller
 Remote Automatic Start-Stop Push Button Station
 Audible Horn Alarm
 Low Limit (System Shutdown) Room Thermostat

FA/FILTER SECTION
 FA Hood
 FA Hood with 2" Permanent Clean Panels
 Walk in FA/Filter Service Compartment with
 Manual Pressure or Time Controlled Auto. Roll. Basket Bag 2" Prim. Filters.
 Qty. Size Qty. Size Sq. Ft. F.A.

MISC.
 Automatic Inlet Discharge Two Position Damper with Motor and End Switch
 Insulated Cabinet
 Factory Prefabricated Curt.
 Side and Rear Service Platform with Guard Rail
 Discharge Air Diffuser
 Blower and Drive Vibration Isolator
 Foot Mounted or Hanger Type Unit Vibration Isolator

50323
 650423
 650523
 51723
 51223
 93041501

930401
 930101
 QTY

KEY PUNCHED
 DEC 12 1973

Total Shipping Weight 6000

TOTAL LIST PRICE



JJ, JK and JL Fans

SERVICE BULLETIN
SB-42-110

REPLACES 42:110-A

30-4415

SEP 5 1984

**Please Read These
Instructions Before
Using This Equipment**

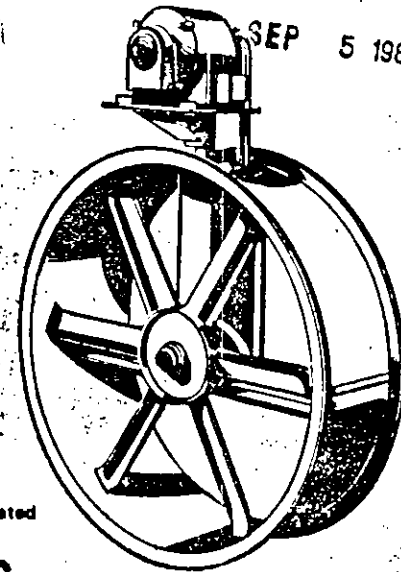

JL Fan Illustrated

INSTRUCTIONS

DESCRIPTION

These exhaust fans are specially designed to exhaust fumes, vapors and overspray from a working area, such as a spraybooth.

INSTALLATION

Fans may be installed either vertically or horizontally.

MOUNTING PROCEDURE

1. Mount fan in desired location using overhead beams, wall or like for support. DO NOT permit fan to rest on booth WITHOUT additional support (angle frame bracing or other support). Fan connector rings are necessary for both suction and exhaust sides of fan. These connector rings provide the union between the fan housing assembly and the exhaust stack.

It is advisable to install a length of exhaust pipe with an automatic damper and access door between fan and booth outlet. When fan is mounted directly on booth (with proper support) the exhaust section directly behind the fan should have an automatic damper and access door. The damper prevents a back draft when fan is not in use.

To mount fan in window or wall, fit housing into window or wall opening. Seal space between housing and window with sheet metal. Seal space between housing and wall with cement.

Fan should be protected with a wire screen to prevent contact with fan blades.

2. Slide motor bracket (5 or 10) into sleeve in belt guard.

3. Install belts (30). Align motor and fan pulley (2 and 17) so that belts are not twisted. Belts may be tightened by turning adjusting screw (11) up with a wrench placed at squared head of screw. Belt play should be approximately 1 inch.
4. Tighten set screws (29) and insert stop pin (13) at bottom of motor bracket post. Hold stop pin (13) in place with cotter pins (12).
5. Wire motor to main electrical source - see chart 4 for correct wire size, electrical current should correspond with data on motor nameplate.

Use manual or magnetic motor starter with thermal overload protection. Refer to motor nameplate data for full load current of motor in order to select proper size starter and proper rated thermal overload heaters for starter.

It is advisable to locate an adequately fused safety switch near the motor, so that when it becomes necessary to investigate trouble with motor, the switch can be turned off.

All wires must be encased in conduit, however, a short flexible explosion proof coupling must be provided at motor in order to facilitate movement of motor on adjustable bracket when installing fan belts.

All conduits where wire is spliced and when located in hazardous area, must be sealed with a sealing compound.

Wiring, fusing and overload protection must be in accordance with local code requirements.

IT IS RECOMMENDED THAT INSTALLATION OF ANY ELECTRICAL EQUIPMENT, OR RELATED DEVICES BE DONE BY A COMPETENT LICENSED ELECTRICIAN.

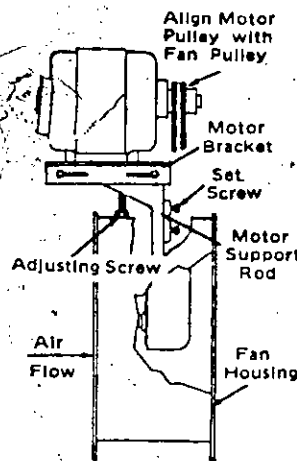

FIGURE 1

Ass'y motor	Motor H.P.	Motor Characteristics	Ref. No. 1		Ref. No. 2		Ref. No. 30	
			Motor	Shaft and Bore Size	Motor Pulley	"V" Belt	Qty.	
JK-4831	2	200/60/3 Open 230/460/60/3 Open	MO-6210 MO-6211	7/8	PU-2540	UAG-4	2	
JK-4836		200/60/3 Expl. Prf. 200/60/3 Tot. Enc. 230/460/60/3 Expl. Prf. 230/460/60/3 Tot. Enc.	MO-6278 MO-6253 MO-6279 MO-6254		PU-2536			
JK-4832	3	200/60/3 Expl. Prf. 200/60/3 Tot. Enc. 230/460/60/3 Expl. Prf. 230/460/60/3 Tot. Enc.	MO-6377 MO-6351 MO-6378 MO-6352	1-1/8	PU-2542	BT-48	3	
JK-4833		200/60/3 Open 230/460/60/3 Open	MO-6309 MO-6310		PU-2543			
JK-4834	5	200/60/3 Expl. Prf. 200/60/3 Tot. Enc. 230/460/60/3 Expl. Prf. 230/460/60/3 Tot. Enc.	MO-6477 MO-6451 MO-6478 MO-6452	1-3/8	PU-1562	BT-48	3	
JK-4835		200/60/3 Open 230/460/60/3 Open	MO-6407 MO-6408		PU-1597			
JK-4838	7-1/2	200/60/3 Expl. Prf. 200/60/3 Tot. Enc. 230/460/60/3 Expl. Prf. 230/460/60/3 Tot. Enc.	MO-6577 MO-6551 MO-6578 MO-6552	1-3/8	PU-2631			
JL-4846	2	115/230/60/1 Expl. Prf. 115/230/60/1 Tot. Enc.	MO-6276 MO-6252	1-1/8	PU-2529	BT-48	2	
JL-4847		200/60/3 Open 230/460/60/3 Open	MO-6210 MO-6211	7/8	PU-2530			
JL-4854		200/60/3 Expl. Prf. 200/60/3 Tot. Enc. 230/460/60/3 Expl. Prf. 230/460/60/3 Tot. Enc.	MO-6278 MO-6253 MO-6279 MO-6254		PU-2528			
JL-4848	3	200/60/3 Expl. Prf. 200/60/3 Tot. Enc.	MO-6377 MO-6351	1-1/8	PU-2531	BT-48	3	
JL-4849		200/60/3 Open 230/460/60/3 Open	MO-6309 MO-6310		PU-2533			
JL-4850	5	200/60/3 Expl. Prf. 200/60/3 Tot. Enc. 230/460/60/3 Expl. Prf. 230/460/60/3 Tot. Enc.	MO-6477 MO-6451 MO-6478 MO-6452	1-1/8	PU-1567	BT-128	3	
JL-4851		200/60/3 Open 230/460/60/3 Open	MO-6407 MO-6408		PU-1568			
JL-4852	7-1/2	200/60/3 Expl. Prf. 200/60/3 Tot. Enc. 230/460/60/3 Expl. Prf. 230/460/60/3 Tot. Enc.	MO-6577 MO-6551 MO-6578 MO-6552	1-3/8	PU-2611	BT-128	3	
JL-4853		200/60/3 Open 230/460/60/3 Open	MO-6507 MO-6508		PU-2615			
JL-4853	10	200/60/3 Expl. Prf. 200/60/3 Tot. Enc. 230/460/60/3 Expl. Prf. 230/460/60/3 Tot. Enc.	MO-6677 MO-6651 MO-6678 MO-6652					

CHART 3 CONCLUDED

old part

Ref. No.	Part Nos. for All JJ Fans	Part Nos. for All JK Fans	Part Nos. for All JL Fans	Description	Qty.
1	See Chart 3	See Chart 3	See Chart 3	Motor	1
2	See Chart 3	See Chart 3	See Chart 3	Motor Pulley	1
3	(See Note 1)	SS-1025	SS-1031	Machine Bolt	4
4	SS-1503	SS-1503	SS-3607	Lock Washer Medium	4
5	42251-027	42251-027	42251-027	Motor Bracket (See Note 2)	1
6	36214-148	36214-148	36214-148	Motor Bracket Clip	4
7	SS-24	SS-24	SS-24	Hex Head Cap Screw 3/8-16x7/8"	4
8	SS-657	SS-657	SS-657	Hex Nut 5/16-18	4
9	SS-3607	SS-3607	SS-3607	Lock Washer Medium 3/8"	10
10	-	-	42331-010	Motor Bracket (See Note 2)	1
11	JJ-160	JJ-160	JJ-160	Adjusting Screw	1
12	SS-622	SS-622	SS-622	Cotter Pin 5/32x1"	2
13	JJ-109	JJ-109	JJ-109	Stop Pin	1
14	SS-615	SS-638	SS-638	Cotter Pin	2
15	SS-3171	SS-3172	SS-3172	Castle Nut	2
16	SS-1532	SS-1534	SS-1534	Wrought Washer	2
17	JJ-150	JK-254	JK-254	Fan Pulley	1
18	SS-12010	SS-12011	SS-12011	Snap Ring	1
19	SS-12004	SS-12005	SS-12005	Bearing	1
20	JJ-158	JK-263	JK-263	Fan Shaft	1
21	SS-1578	SS-10468	SS-10468	Key	1
22	SS-1578	SS-10472	SS-10472	Key	1
23	SS-12003	SS-12004	SS-12004	Bearing	1
24	-	JK-265	-	Sleeve	1
25	SS-25	SS-25	SS-25	Hex Head Cap Screw 3/8-16x1"	6
26	JJ-157	JK-264	JK-264	Bearing Housing	1
27	JJ-68	JK-165	JL-13	Fan Blade	1
28	JJ-4211	JK-4211	JL-414	Fan Housing Assembly	1
29	SS-438	SS-438	SS-438	Cup Pointed Set Screw 1/2x3/4"	2
30	See Chart 3	See Chart 3	See Chart 3	Belt	See Chart 3 for Qty.

CHART 2

Note 1: Order SS-3353 for JJ-4834 and JJ-4835. Order SS-1025 for all other JJ fans.
 Note 2: (Ref. No. 10) 42331-010 used on JL-4852 and JL-4853.

JK-4217 COMPLETE HUB ASSEMBLY 324.00

INSTALLATION CONTINUED

6. Connect conduit box to motor housing. All fan motors of a multi-fan exhaust booth must be connected to a single switch. This will insure efficient booth operation at all times.

NOTE: To select the correct wire size see Chart 4. and study the following example.

An exhaust fan with 230 volt motor is to be located 200 feet from main current line. Let us assume the motor nameplate is stamped 7 Amperes. Reference to table shows that columns 1, 2, 3, and 4 from the left indicate amperes for given voltages. Follow down column under 230 volts to figure 7; then cross to column under 200 feet. A No. 11 wire size should be used. If several motors are to be connected to the same line use the ampere figures and the distance of the farthest motor from main current line to determine correct wire size. If the exact ampere rating is not shown on table use the next larger.

When fan is installed outside building, a fan motor house must be provided to protect motor from weather.

Exhaust stack should be smooth sheet metal strongly erected and supported. Stack sections should be smoothly joined so as to present a minimum of air passage obstruc-

tion. Seams should be leak-proof. Stack diameter must not be reduced below the recommended 34" for JJ fans, 42" for JK fans and 48" for JL fans. Elbows should be kept to a minimum. They must have a throat radius not less than the diameter of the exhaust stack.

Cleanout doors should be provided about every 10 feet of stack. Cleaning of exhaust stack will be easier if sprayed before erection with a material that aids in cleaning.

Whenever stack passes through a nonfireproof roof a suitable collar or roof flashing should be installed and must provide sufficient clearance to protect combustible material against ignition by radiated heat.

PREVENTIVE MAINTENANCE

Fan blades (27) should be kept clean. Dirty blades are not only a fire hazard but also tend to throw the fan out of balance resulting in wear and breakage.

A strippable coating may be sprayed on the blades (27) and all exposed parts to aid in cleaning.

Follow motor manufacturer's recommendations for motor lubrication. If motor repairs are required, contact the nearest authorized distributor or agent for the motor.

ALWAYS REFER TO CURRENT
DeVILBISS SERVICE PARTS
PRICE LIST FOR AVAILABILITY
BEFORE ORDERING PARTS.

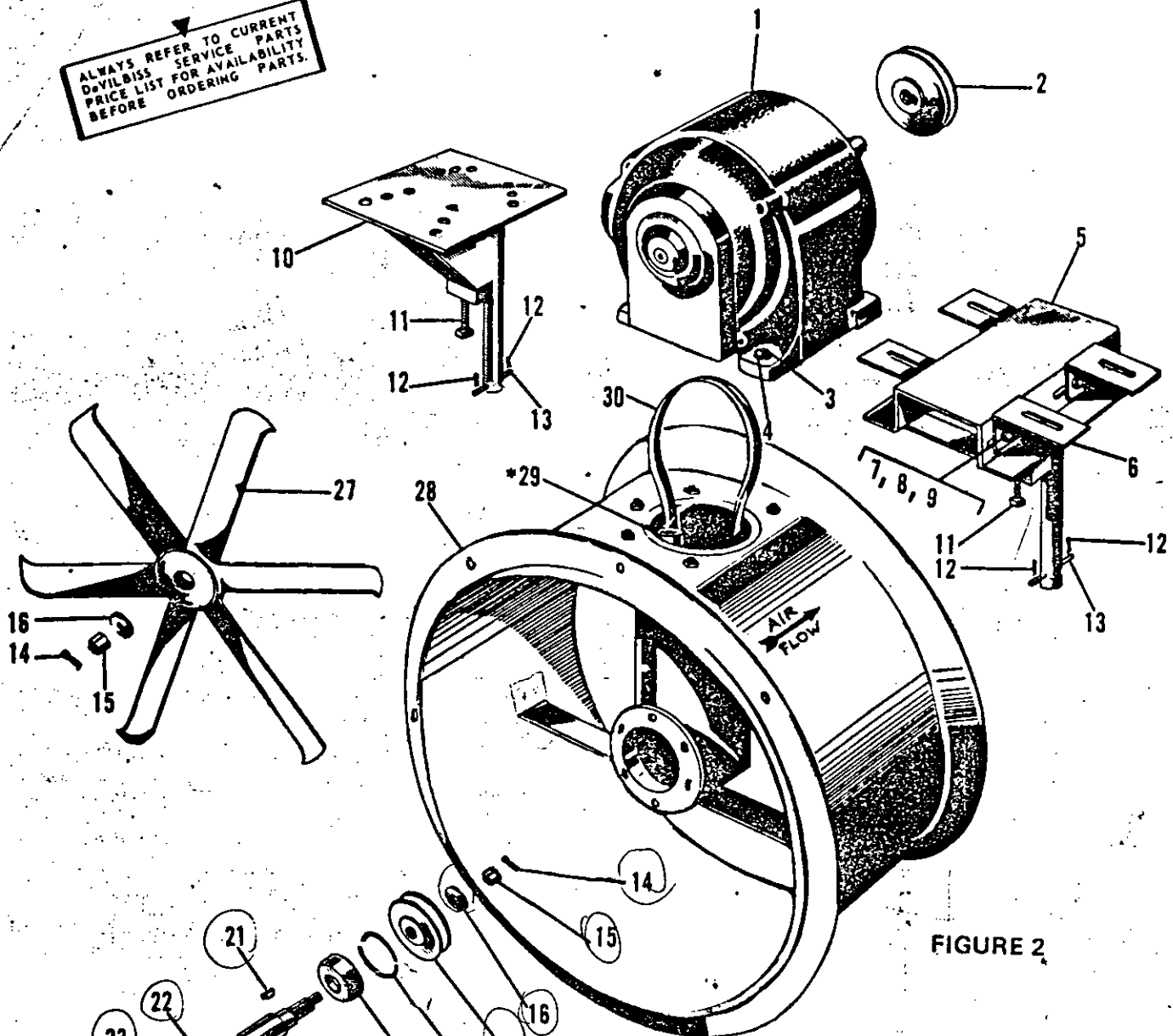

FIGURE 2

*Indicates parts not visible on drawing.

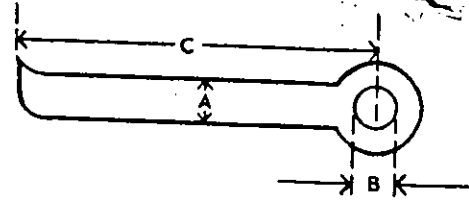
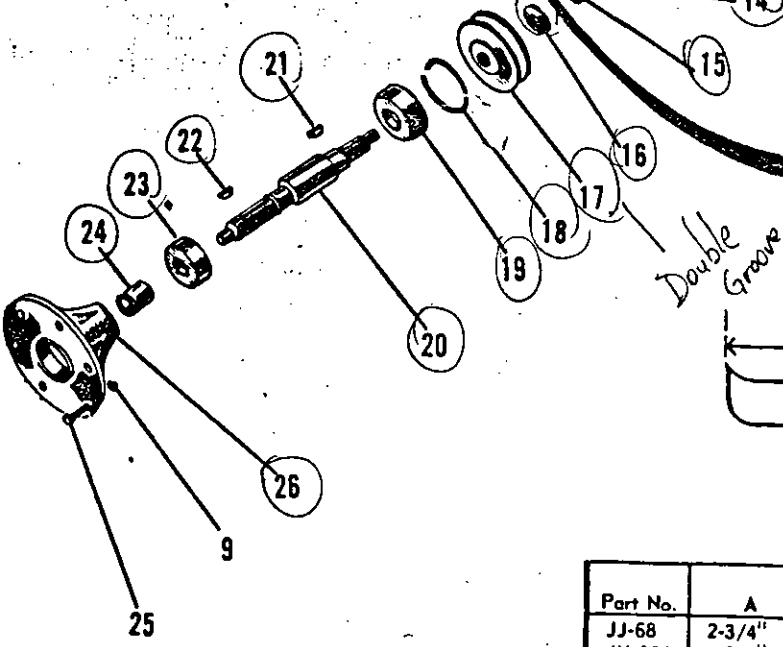
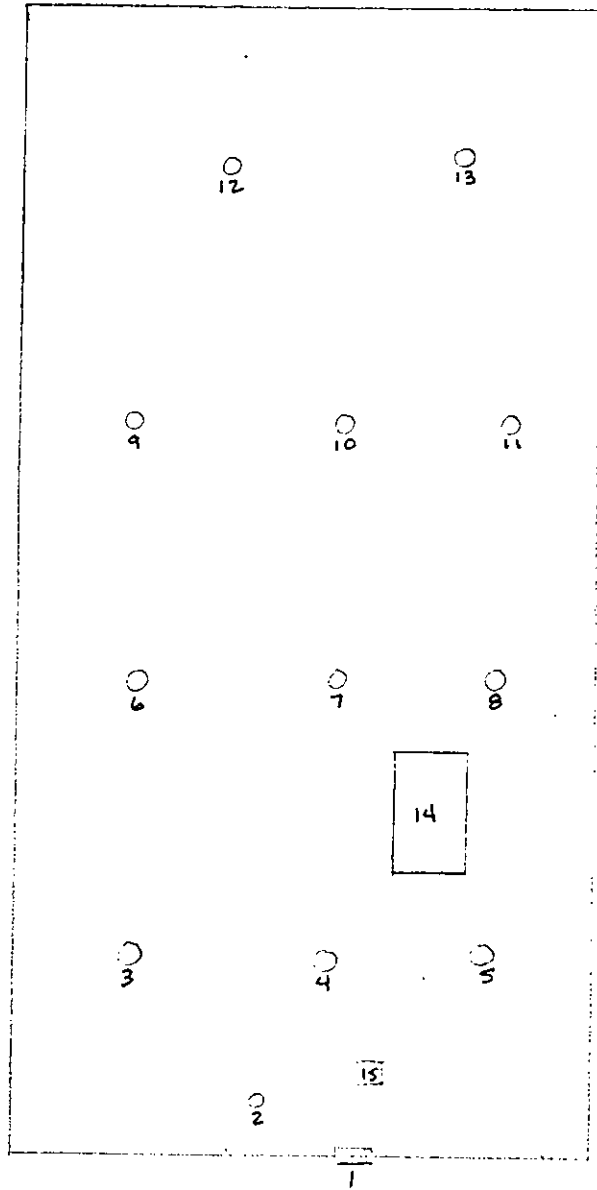
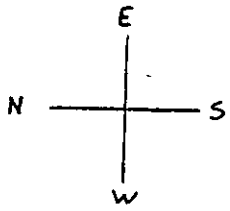

FIGURE 3

Part No.	A	B	C	No. of Blades	Material	Stack Size
JJ-68	2-3/4"	1-1/16"	16-1/2"	6	Aluminum	34"
JK-165	3-1/2"	1-3/8"	20-3/8"			42"
JL-13	3-13/16"	1-3/8"	23-3/8"			48"

CHART 1

ASSEMBLY



ASSEMBLY

DESCRIPTION	H. P.	FAN	MANUFACTURE
1. FAN MODEL SBW30-5, 11,260 CFM	1 1/2		BREEZEMAKER
2. VENTILATOR		30"	DOMEX PENN
3. FAN 480V	1 1/2	32"	
4. FAN 480V	1 1/2	32"	
5. FAN 480V	1 1/2	32"	
6. FAN 480V	1 1/2	32"	
7. FAN 480V	1 1/2	32"	
8. FAN 480V	1 1/2	32"	
9. FAN 480V	1 1/2	32"	
10. FAN 480V	1 1/2	32"	
11. FAN 480V	1 1/2	32"	
12. VENTILATOR		46"	DOMEX PENN
13. VENTILATOR		46"	DOMEX PENN
14. AIR HANDLERS DFT2250AJA221A4G4GA41130101	25		TRANE
15. SMOKE EATER MODEL F70			HONEYWELL

2701 Atlantic Boulevard
Jacksonville, Florida 32207
(904) 396-3424
Fax: 904-396-7299

B R E E Z E M A K E R F A N C O M P A N Y
C A R E A N D M A I N T E N A N C E
S P E C I F I C A T I O N S H E E T
W A R R A N T Y

for

SEA RAY BOATS, INC.
Merrit Island, FL 32953
Purchase Order # MI104-7450

CARE AND MAINTENANCE

Good fan maintenance requires regular and systematic inspection of all fan parts. Severity of the application should determine frequency of inspection.

Regular fan maintenance should include the following:

1. PROPELLER- The fiberglass propeller in a power roof ventilator fan must be kept reasonably clean if it is to perform properly. Fans handling fresh air for ventilating purposes will seldom need cleaning. Fans exhausting process air should be cleaned as required. Dirt or chemical deposits will usually build up on a propeller evenly, and they present no problem to performance or operation until they become thick enough to break away in crustlike pieces. When this happens, the resulting vibration could be serious. Crustaceous accumulations should be removed by detergent soap or scraping. If the propeller shows excessive wear it should be replaced immediately. Refer to General Installation and Maintenance instructions for proper procedure in removing and replacing the propeller.

2. V-BELT DRIVE- Check V-belt drive for proper alignment and tension.

3. FAN BEARINGS- Lubricate the bearings (if belt driven). Ball bearing lubrication instructions are detailed on page 1 of General Installation and Maintenance.

4. Check Tightness of all screws and bolts throughout fan assembly.

LUBRICATION SCHEDULE

SHAFT SIZE INCHES	OPERATING SPEED (RPM)							
	300	1000	1500	2000	2500	3000	3600	4000
	RELUBRICATION CYCLE (MONTHS)							
1/2 thru 1	6	6	6	6	6	6	4	4
1-1/16 thru 1-7/16	6	6	6	6	6	6	4	4
1-1/2 thru 1-3/4	6	6	6	4	4	2	2	2
1-7/8 thru 2-3/16	6	6	4	4	2	2	1	1
2-1/4 thru 2-7/16	6	4	4	2	2	1	1	1
2-1/2 thru 3	6	4	4	2	1	1	1	
3-7/16 thru 3-1/2	6	4	2	1	1	1		
3-15/16 thru 4	6	4	2	1	1			

SPECIAL LUBRICATION

High Temperature and High Moisture

AIRSTREAM TEMPERATURE	HOURS
To 250°F.	4500
To 350°F.	1500
To 500°F.	1000
Wet Atmosphere at Room Temperature	1000 to 1500

BEARING MOUNTING PROCEDURE

It is important to follow the assembly and alignment procedure when making an installation of replacement bearings. Inspect the shaft for wear at the bearing mounting positions. Shaft diameter should not be undersized more than commercial ground and polished tolerances. Excessive undersizing will result in rapid wear.

1. Place new bearings on shaft loose with locking collars toward the ends of shaft shown in illustration. Drop mounting bolts in place, snug them and adjust position of shaft with proper spacing at either end.

2. Center both shaft ends in housing, using the clearance in the mounting holes for horizontal adjustment and shims if necessary for vertical adjustment.

3. Tighten the bearings to the base plate and check the position of the shaft again. Before tightening the locking collars be sure the shaft and bearings are in proper alignment. The shaft should slide freely end to end.

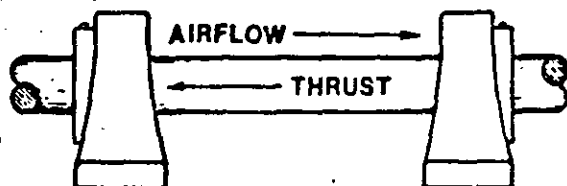

Two Bearing Drive.

4. Tighten the eccentric cam locking collar of the bearing at the propeller end. (The locking collar design provides a positive lock of the wide inner ring bearing to the shaft. To tighten, turn the locking collar in direction of shaft rotation to the lock position; then tighten the collar set screw.)

5. Grasp the sheave end of the shaft and pull it out; at the same time tap the locking collar of the sheave end bearing with a soft mallet in the opposite direction, toward the propeller.

6. The final step is to tighten the sheave and bearing eccentric cam locking collar.

For special heavy-duty bearings a spring locking collar is used. The two knurled cup-point set screws extend through the inner ring of the bearing and lock firmly onto the shaft. Tighten the propeller end collar first then take hold of the sheave end of the shaft, pull and tighten the locking collar. The locking collar is tightened by using the two set screws mentioned above.

BELT TENSION

Belt tension is very important to the proper operation of a fan and to the service life of a V-belt drive. A new fan will be received with its belts properly adjusted; however, all V-belts stretch in the first few hours of operation. It will be necessary to readjust the belt tension after eight hours of running. After 100 hours the belts should again be adjusted. Thereafter, periodic inspection is recommended so belts may be adjusted or replaced when necessary.

1. To adjust the belts, loosen the motor hold-down bolts. Tighten the belt, using the motor base adjusting screw until the belt appears to be taut. You should be able to deflect the belt slightly by squeezing the two sides between thumb and fore finger, and the belt should snap back into position when released.

2. Retighten the motor hold-down bolts and start the fan. If the belt screeches on start-up, it is too loose and should be tightened further.

3. Allow the fan to run for awhile, stop the fan, and check the temperature of the sheave with your hand. If the sheave gets too hot to touch, the belt is probably too tight.

V-belt drives on BREEZEMAKER fans are purposely sized to handle considerably more load than would be necessary for normal drive design. This is done to prolong the life of the drive and provide for minimum maintenance. Belts should be replaced when they have obviously become worn, even though they are still operating. A badly worn belt will also cause undue wear on the sheave. Replace belts when they show definite signs of wear; or the sheaves will become worn to where they also must be

replaced. Never put new belts on a badly worn sheave. This will reduce the capacity of the drive and cause excessive belt wear.

Most BREEZEMAKER fans are provided with an adjusting screw as part of the motor base for easy setting of belt tension. However, small fans or fans using small horsepower motors may have only a slotted base plate. When you adjust the belt tension by moving a motor on a slotted base, be sure that you block the motor tightly and squarely before tightening the hold down bolts, keeping the motor sheave in line with the belt. The motor sheave must be parallel to and in line with the fan sheave.

When you make replacement of belts on a multi-groove drive, be sure they are used in a matched set. If you aren't sure the belts are matched, observe them in operation. The tight side should be perfectly straight, and the belts should run smoothly and in line. The slack side should bow out considerably farther than another, it is an indication that the belts are not matched and should be changed. If there is only a slight difference the normal stretching in the first hours of operation will equalize the belt lengths and the belts will be well matched.

REPLACING BELTS AND BEARINGS

Worn belts may be easily replaced without removing the fan from the system.

1. Loosen the motor hold-down bolts and move the motor toward the fan. (This is done by turning a jackscrew which is part of the motor base on models having larger motors.) The belts may be slipped off the motor

sheave and then easily removed from the sheave on the propeller shaft.

2. Check the numbers on the belt and make the replacement with a belt having the same length and section.

3. Adjust motor outward to tighten the belt (see instructions on belt tension) and tighten the motor hold-down bolts. Be sure that the motor is not cocked at an angle and that the end face of the motor sheave is parallel to the end face of the driven sheave.

Since the new belts have a tendency to stretch, it will be necessary to re-adjust the belt tension after a few hours of run-on.

1. Fan bearings may be lubricated by refilling the automatic "Lube Site" system installed as standard on BREEZEMAKER fans. Removal of the "Lube Site" is not necessary and can be recharged using a common hand operated grease gun. Should any dirt or contaminates clog the "Lube Site" it can be removed and cleaned using a suitable solvent.

2. Bearings are held in place with ordinary class 5 capscrews and lock-nuts. Use new capscrews and lock-nuts to make the replacement, particularly if these show signs of corrosion.

The belts, sheaves, bearings, and shaftings used in all BREEZEMAKER fans are of standard dimension and manufacture. New parts are available from the local distributor.

ADJUSTING VARIABLE PITCH SHEAVES

Many BREEZEMAKER belt driven fans are furnished with variable-pitch motor sheaves. Sheaves may be adjusted for lower fan speeds without concern of

over-load motors. When adjusting sheaves to increase fan speed, check motor current to be sure motor is not overloaded. Keep motor current within nameplate and service factor ratings

The sheaves used are the VP type and are easily adjusted. They come in various styles, depending upon the size drive and motor shaft, all fitted with hollow head knurled point safety set-screws.

The following steps should be taken to adjust the pitch diameter:

1. Release belt tension and remove belt or belts from sheave.
2. Loosen setscrew and remove key holding adjustable half of the groove (keys used on styles 2,3,5, and 6 only). With styles 3 and 6 it may be necessary to remove the sheave from the shaft to remove the key.



Type 1
Finished Bore Type
S. S. on flat



Type 2
Finished Bore
Key Type



Type 3
Bushing Type
with Key



Type 4
Finished Bore Type
S. S. in Keyway



Type 5
Finished Bore—Key Type

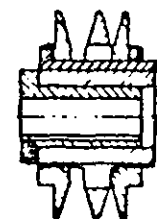

Type 6
Bushing Type—With Key

3. Screw adjustable half of sheave out for a smaller pitch diameter (decreased speed), or in for a larger pitch diameter (increased speed). Each one-half turn will change the

pitch diameter one-tenth of an inch. Adjust two-groove sheaves the same amount on each groove. 4L or A belts will operate satisfactorily with the sheave fully closed to a maximum of five full turns open. 5L or B belts will operate satisfactorily with the sheave one full turn open to a maximum of six full turns open. (This will insure full contact of the sheave in the groove.)

4. Replace the key and tighten set-screw to lock sheave half in position.
5. Replace the belts and tighten to proper tension. If extreme amount of adjustment has been made, it may be necessary to replace belts with another length.

NOTE: Heavy-duty drives requiring three-groove sheaves, motor sheaves larger than 7" pitch diameter, or belt larger than B section require MVP sheaves and are available only on special order.

TYPICAL MOTOR CURRENT AND STARTER SIZE

Amperes shown are nominal and were used for sizing of the starters only. These values are not to be used for sizing heaters or other overload protection. Consult the motor nameplate for the correct motor current and refer this to the heater size chart for the particular starters used.

NOTE: When sizing overload heaters, conditions under which the starters will operate must be considered. Enclosed starters should have heaters on size enclosures are subjected to external heat, such as radiant heat from the sun or heat accumulation under a roof size even more. Experience with the operating conditions and measurement on the actual line current will aid in proper sizing on heaters.

HP	Three Phase						Single Phase			
	230 V		460 V		575 V		115 V		230 V	
	Amps	Starters	Amps	Starters	Amps	Starters	Amps	Starters	Amps	Starters
1/4		(N)		(N)		(N)	5.8	(N)	2.4	(N)
1/3	1.7	00	.9	00			7.2	(N)	3.0	(N)
1/2	2.0	00	1.0	00	.8	(N)	9.8	(N)	4.4	(N)
3/4	2.4	00	1.4	00	1.1	(N)	13.0	(N)	6.9	(N)
1	3.5	00	1.8	00	1.4	(N)	16.0	(N)	8.0	(N)
1 1/2	5.0	00	2.5	00	2.0	(N)	20.0	(N)	10.0	(N)
2	6.5	0	3.3	00	2.6	(N)	24.0	(N)	12.0	(N)
3	9.0	0	4.5	0	4.0	(N)	34.0	(N)	17.0	(N)
5	15.0	1	7.5	0	6.0	(N)			28.0	(N)
7 1/2	22.0	1	11.0	1	9.0	(N)			40.0	(N)
10	27.0	2	14.0	1	11.0	(N)			50.0	(N)
15	40.0	2	20.0	2	16.0	(N)				
20	52.0	3	26.0	2	21.0	(N)				
25	64.0	3	32.0	2	26.0	(N)				

**INSTALLATION INSTRUCTIONS
FOR PROPELLERS EQUIPPED WITH
BROWNING MALLEABLE IRON SPLIT
TAPER BUSHINGS**

BREEZEMAKER propellers are furnished with split taper bushings for mounting the propeller to the shaft. When properly assembled, the bushings grip the hub with a positive clamping action.

A. Bushing barrel and bore of propeller are tapered this assures concentric mounting and a true running propeller.

B. Capscrews, when tightened, lock bushing in propeller. Use plated capscrews threaded full length.

BUSHING NO.	DIAMETER	LENGTH	TORQUE FT. LBS.
H	1/4-20	1 1/2"	7 1/2
P-1	5/16-18	1 1/2"	13
P-2	5/16-18	1 3/4"	13
Q-2	3/8-16	2 1/2"	24
R-2	3/8-16	3"	24

C. Bushing is split so that when the locking capscrews force bushing into tapered bore, the bushing grips the shaft with a positive clamping fit, this will withstand vibration and punishing loads without being

loosened.

D. Propeller and bushing assembly is keyed to shaft and held in place by compression this gives added driving strength.

E. Propeller is easily removed from shaft by inserting and tightening two of the capscrews into the tapped holes in the bushing flange this forces the bushing loose from the propeller and releases the compression so that the entire assembly will slide from the shaft.

Put bushing loosely into propeller. Do not press or drive. Start capscrews by hand, turning them just enough to engage threads in tapped holes on propeller. Do not use a wrench at this time. The bushing should be loose enough in the propeller to move slightly.

Be sure shaft and keyway are smooth and clean. Check key size with both shaft and bushing keyways. Slide propeller and bushing assembly onto shaft, making allowance for end play of shaft to prevent rubbing. Do not force propeller and bushing onto shaft. If it does not go on easily check shaft, bushing and key sizes.

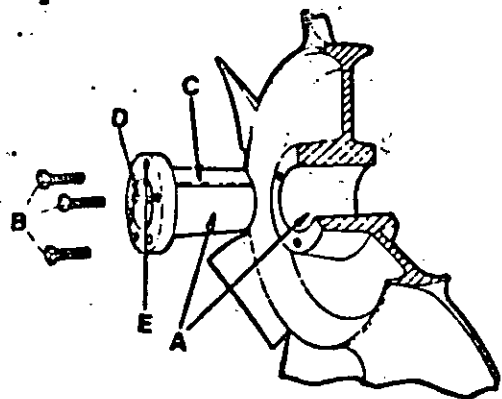

Tighten capscrews progressively with wrench. Do this evenly as in mounting an automobile wheel. Take a part turn on each capscrew successively until all are tight. These capscrews force the taper bushing into the hub which in turn compresses the bushing into the shaft. This makes

a positive clamping fit. The torque must not exceed that shown in table.

WARNING: Do not attempt to pull bushings flange flush with hub end-there should be 1/8" to 1/4" clearance when tightened.

REMOVING PROPELLER ASSEMBLY FROM SHAFT

1. Remove all three capscrews from propeller and hub assembly.
2. Start capscrews into the threaded holes in the bushing flange.
3. Tighten each bolt part of a turn successively to force the propeller off the bushing.
4. Pull the bushing off the shaft. If the assembly has been in place some time it may be necessary to use a wheel puller to remove the bushing. Never use a wheel puller on the propeller.

GENERAL INSTALLATION AND MAINTENANCE

LUBRICATION INSTRUCTIONS FOR BALL BEARING MOTORS

Grease-lubricated bearings, as furnished, are adequate for a long period of operation without relubrication. A good maintenance schedule for regreasing will vary widely depending on motor size, speed and environment.

The table listed below suggests relubrication intervals for motors on normal, steady running, light duty indoor loads in relatively clean atmosphere at 40°C. (105°F) ambient temperature or less. Fractional horsepower motors follow a similar schedule to that shown under frames 143 to 215T.

Motors with no provision for lubrication are equipped with sealed bearings and require no maintenance. Motors mounted in inaccessible locations are provided with extended grease lines to facilitate lubrication. They are equipped with relief fittings to prevent over-lubrication. The grease lines are filled with lubricant at the factory.

Type of Enclosure	Insulation	FRAME SIZE		
		143 to 215T	254 to 326T	364 to 449T
Open - DP	B	2 years	18 months	1 year
Enclosed - FC Open - DP	B F	18 months	1 year	9 months
Enclosed - NV Enclosed - FC Open - DP Enclosed - Lint Free - FC	B F H B	1 year	9 months	6 months
Enclosed - NV Enclosed - FC Enclosed - Lint Free - FC	F H F	9 months	6 months	3 months

PROCEDURE FOR RELUBRICATION

1. Stop motor.
2. Remove grease relief plugs in bearing housings.
3. Grease with hand gun until new grease appears at relief hole.
4. Run motor for ten minutes before replacing relief plugs.

CAUTION: Do not overlubricate. This is a major cause of bearing and motor failure. Make sure dirt and contaminants are not introduced when adding grease.

Because BREEZEMAKER fans are furnished with "LubeSite" grease feeders as standard refer to the LubeSite manual for proper procedures in refilling the grease reserve unit.

TYPE OF GREASE

Lubricate with or equivalent to the following greases:

- Chevron BRB-2 - Standard Oil of Calif.
- SRI-2 - Standard Oil Company.
- Alvania #2 - Shell Oil Company.

For motors lubricated with special grease check lubrication tag on motor.

NOTE: FOR MOTORS OVER 1800 RPM
Use $\frac{1}{2}$ of tabled period.

FOR HEAVY DUTY-DUSTY LOCATIONS
Use $\frac{1}{2}$ of tabled period.

FOR SEVERE DUTY HIGH VIBRATION
SHOCK
Use $\frac{1}{3}$ of tabled period.

VOLUME REFERENCE TABLE

Shaft Diameter	Amount of grease to add.
3/4" to 1 1/4"	1/8 cu. in. or 0.1 oz.
1 1/4" to 1 7/8"	1/4 cu. in. or 0.2 oz.

BREEZEMAKER

FAN COMPANY

SPECIFICATION SHEET

DATE
2/23/89

TO <u>Kent Williams</u> <hr/> <hr/>	FROM <u>Sea Ray Boats</u> <hr/> <u>100 Sea Ray Dr.</u> <hr/> <u>Merrit Island, Fl. 32953</u> <hr/>
---	--

ORDER TAKEN BY: <u>Ed</u>	DATE PROMISED: <u>Feb 10, 1989</u>	CUSTOMER P.O.	CONTACT:	TELEPHONE	S.O.#
------------------------------	---------------------------------------	---------------	----------	-----------	-------

QTY.	MODEL #
1.	SBW30-5
<input type="checkbox"/> ROOF VENTILATORS <input type="checkbox"/> WALL EXHAUST <input type="checkbox"/> AXIAL FANS <input type="checkbox"/> CIRCULATOR <input type="checkbox"/> DIRECT DRIVE <input type="checkbox"/> SPECIAL	
C.F.M. <u>11,260</u> @ <u>1/8"</u> S.P. RPM _____	
GUARD: SIZE: _____	
<input type="checkbox"/> BIRD SCREEN	
CURB: GAUGE _____ SIZE: _____	
SHUTTER SIZE _____ TYPE _____	
1	BLADE DIA. <u>30</u> PITCH <u> </u> wide <input checked="" type="checkbox"/> FIBERGLASS <input type="checkbox"/> STEEL <input type="checkbox"/> ALUMINUM

MOTOR:

MFG. Baldor MODEL M3154T
 H.P. 1 1/2 RPM 1725 FR 145

BASE RIGID RESILIENT
 ENCLOSURE OPEN TEFC XPL
 VOLTAGE 10-115/230 30-230-460
 SPECIAL _____

DRIVE:

BEARINGS MFG. Fafnir SIZE 1"
 SHAFT DIA. 1" LENGTH 17"
 SHEAVES MOTOR BK 5.0
 FAN SHAFT BK 120 1-1
 BELT MFG MBL SIZE B-75

SPECIAL INSTRUCTIONS

Weather guard louver

WARRANTY

Breezemaker Fan Company warrants this equipment to be free of defects in materials workmanship for one year from date of shipment. Any units or parts which prove to be defective and are reported during the warranty period will be replaced at our option when returned to the factory. Transportation charges prepaid. Motor is warranted by the motor manufacturer for one year, if the motor becomes defective in the warranty period, it should be taken to the nearest authorized motor service station. If this is not done, the motor manufacturer will not warrant the motor. Call factory for instructions if authorized service station is not known. Breezemaker Fan Company will not be responsible for any installation, removal or re-installation costs or any consequential damage resulting in failure to meet conditions of any warranty.

FACTORY REP: Kent Williams

Purchaser: Sea Ray Boats

Effective Date: Feb. 6, 1989

100 Sea Ray Drive

Merrit Island, Fl. 32953

Model #: 1) SBW30-5 with weather guard louver

BREEZEMAKER FAN COMPANY, INC.
TAMPA, FLORIDA 33605

Honeywell

THE F70 IS A SELF-CONTAINED ELECTRONIC AIR CLEANER FOR USE IN BARS, LOUNGES AND COMMERCIAL APPLICATIONS. THE AIR CLEANER IS MOUNTED IN THE ROOM OR AREA WHERE THE AIR IS TO BE CLEANED. A THREE-SPEED FAN CIRCULATES AIR THROUGH PREFILTER SCREENS AND TWO ELECTRONIC CELLS. AIRBORNE PARTICLES SUCH AS DUST, SOOT, POLLEN, TOBACCO AND COOKING SMOKE ARE REMOVED FROM THE AIR CIRCULATED THROUGH THE ELECTRONIC AIR CLEANER.

Three-speed permanently lubricated ball bearing permanent split capacitor motor driven fan circulates up to 1200 cubic feet per minute [2040 m³/h.].

Up to 93 percent efficiency is delivered as measured according to the National Bureau of Standards Dust Spot Method using atmospheric dust, and American Society of Heating, Refrigerating, and Air-Conditioning Engineers Standard 52-76.

Self-regulating power supply output is not affected by moderate fluctuations in line voltage.

Three position adjustable discharge louvers.

Safety interlock switch breaks both sides of the line and prevents operation when dress cover is opened.

Coanda air flow.

Powered from a standard grounded electrical outlet.

May be conduit connected.

Electronic cells, prefilters and intake grille are easily removed for cleaning.

Easily removable power pack for servicing.

Heavy duty commercial cells.

L.R.
5-84

PRINTED IN CANADA

SELF-CONTAINED ELECTRONIC AIR CLEANER

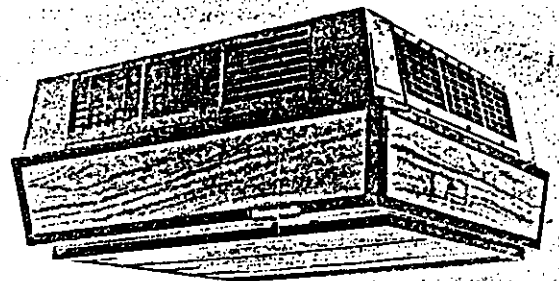

F70C

95C-103202

SPECIFICATIONS

IMPORTANT

SPECIFICATIONS GIVEN IN THIS PUBLICATION DO NOT INCLUDE NORMAL MANUFACTURING TOLERANCES. THEREFORE, THIS UNIT MAY NOT MATCH THE LISTED SPECIFICATIONS EXACTLY. ALSO, THIS PRODUCT IS TESTED UNDER CLOSELY CONTROLLED CONDITIONS, AND SOME MINOR DIFFERENCES IN PERFORMANCE CAN BE EXPECTED IF THOSE CONDITIONS ARE CHANGED.

MODEL. The F70C includes 2 electronic cells, 2 prefilters and a 3-speed fan which discharges air in four directions parallel to the ceiling upon which it is mounted.

POWER CORD: 10 ft [3 m] long, 3-wires — 3 prong plug included with 120 V, 60 Hz models.

AMBIENT TEMPERATURE RATING:

Shipping and Storage — minus 30° F to plus 150° F [minus 34°C to plus 66°C].

Operating — This equipment is intended for use at ambient temperatures normally prevailing in occupiable spaces, which usually are not higher than 25°C [77°F] but may be as high as 40°C [104°F] occasionally for brief periods.

EFFICIENCY: Efficiency ratings are based on National Bureau of Standards Dust Spot Method using atmospheric dust and American Society of Heating, Refrigerating, and Air-Conditioning Engineers Standard 52-76.

CAPACITY:

FAN SPEED	60 Hz		
	cfm	m ³ /h	EFF %
High	1200	2040	81
Medium	1020	1730	85
Low	800	1360	93

ELECTRICAL RATINGS:

Voltage and Frequency — 120 V ac, 60 Hz.
Current and Power Consumption —

FAN SPEED	60 Hz	
	A	W
High	2.6	270
Medium	2.0	215
Low	1.8	185

WEIGHT: 80 lb. [36 kg] shipping, 72 lb. [33 kg] installed, including electronic cells, Each cell weighs 9-1/2 lb. [4.3 kg].

DIMENSIONS: 27 x 27 x 13 in. [690 x 690 x 330 mm].

ACCESSORIES AVAILABLE (Order Separately)

118636B Wall Mounting Kit — includes 2 wall mounting brackets, air cleaner mounting bolts, one blank plate to cover louvers on wall side of air cleaner and mounting hardware.

272575A Blank Plate for Discharge Grille

272574A Ceiling Mounting Kit — includes 4 lag screws and 4 flat washers

272577A Transition Plate, includes mounting hardware.

272596 Charcoal Filter, 1/2 x 19 1/4 x 24 1/4 in. [13 x 502 x 629 mm].

272611 Foam pad to conceal prefilters.

C.S.A. Listed: File No. LR20633.

Underwriters Laboratories Inc. Listed: File E84823.

ORDERING INFORMATION

WHEN PURCHASING REPLACEMENT AND MODERNIZATION PRODUCTS FROM YOUR TRADELINE WHOLESALE OR YOUR DISTRIBUTOR, REFER TO THE TRADELINE CATALOG OR PRICE SHEETS FOR COMPLETE ORDERING NUMBER, OR SPECIFY —

1. Order Number
2. Accessories, if required.

IF YOU HAVE ADDITIONAL QUESTIONS, NEED FURTHER INFORMATION, OR WOULD LIKE TO COMMENT ON OUR PRODUCTS OR SERVICES, PLEASE WRITE OR PHONE:

1. YOUR LOCAL HONEYWELL RESIDENTIAL DIVISION SALES OFFICE (CHECK WHITE PAGES OF PHONE DIRECTORY).
2. IN CANADA — RESIDENTIAL DIVISION CUSTOMER SERVICE HONEYWELL LIMITED, 740 ELLESMERE ROAD SCARBOROUGH, ONTARIO M1P 2V9 (416) 293-8111
3. IN U.S.A. — RESIDENTIAL DIVISION CUSTOMER SERVICE HONEYWELL INC., 1885 DOUGLAS DRIVE NORTH MINNEAPOLIS, MINNESOTA 55422 (612) 542-7500

INTERNATIONAL SALES AND SERVICE OFFICES IN ALL PRINCIPAL CITIES OF THE WORLD

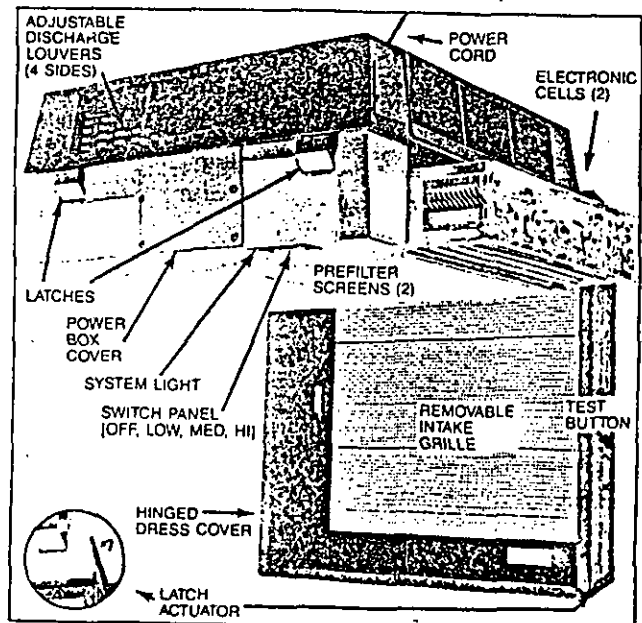
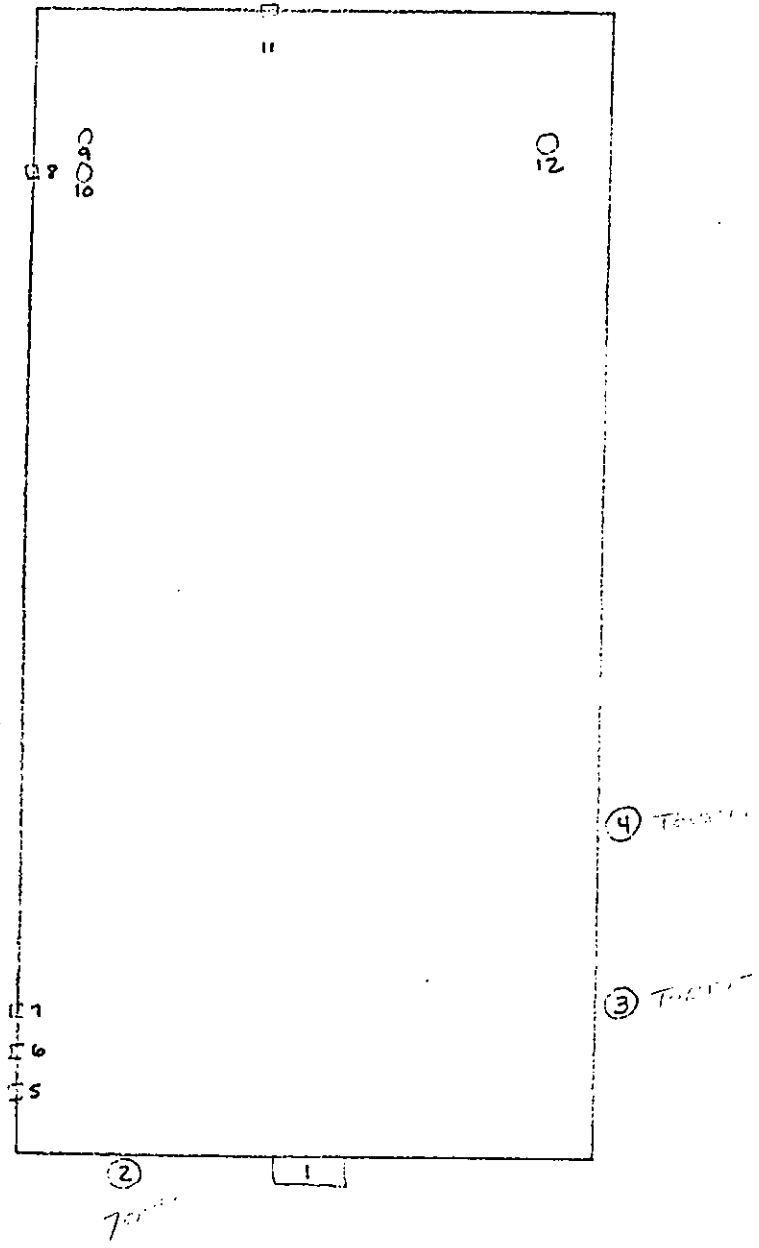
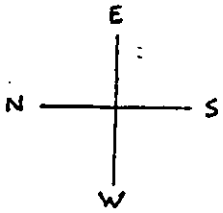

FIG. 1 — F70C COMPONENTS

FABRICATION



FABRICATION

	<u>DESCRIPTION</u>	<u>H.P.</u>	<u>RPM</u>	<u>FRAME</u>	<u>FAN</u>	<u>MANUFACTURE</u>
1.	HEATER	25				
2.	VACUUM WEST	15				TORIT
3.	VACUUM SOUTHWEST	15				TORIT
4.	VACUUM SOUTHEAST	15				TORIT
5.	EXHAUST VACUUM MOLD	3/4	1725	56	42"	DAYTON
6.	SKID SPRAY BOOTH	1	1725	L56H	42"	DAYTON
7.	SKID SPRAY BOOTH	1	1725	L56H	42"	DAYTON
8.	FRAME SHOP EXHAUST	1	1725	L56H	42"	DAYTON
9.	GLUE BOOTH ROOF	5	1740	184T		TOSHIBA
10.	GLUE BOOTH ROOF	5	1740	184T		TOSHIBA
11.	FORMICA AREA EXHAUST	1	1725	L56H	42"	DAYTON
12.	LACQUER SPRAY BOOTH	5	1740	184T		WESTINGHOUSE



SERIES 44

EFFICIENT DESIGN

TORIT's long tapering cone design and high inlet velocity place it in the "high efficiency" class — cyclone separators built for top-level proficiency. In lab tests, Series 44 FM separated 99.2% of steel grindings, 99% of sawdust, and 94% of baking flour by weight. Sturdy steel construction is featured for long-lasting service both inside and out. The doors are felt-gasketed with specially-designed "Positive-Seal" slide gate on the hopper bottom, to assure an airtight seal. A tough weather-resistant finish is standard at no extra cost.

The centrifugal fan design delivers constant high performance at a low horsepower requirement (see multiple rating tables on reverse side). You get longer operation at a lower cost. And this fan is on the clean air side. Grit, dust, chips, tramp iron and other foreign materials are deposited in the hopper *before the dust reaches the fan*. No fan loading or breakage to cost you repair time and money. The TORIT fan is self-cleaning — "fines" which might reach it do not build up on the blades.

The Series 44 Cyclone Collector has a big 103 cubic foot storage capacity. The hopper is designed with a 60° free-flowing taper, terminating in a rugged, trouble-free slide gate which is easy to operate. Each unit is mounted on sturdy steel legs for the greatest stability.

Three-phase motor is end-mounted vertically on the unit. Inlet may be positioned in 15° increments, while exhaust outlet may be positioned in any direction for the most flexible utilization. The Series 44 FM models are designed for outside exhaust. Indoor recirculation of clean, filtered air is available with a highly efficient after-filter arrangement on FB models. A totally enclosed motor couples with the weatherproof finish to ensure long life for outdoor installations.

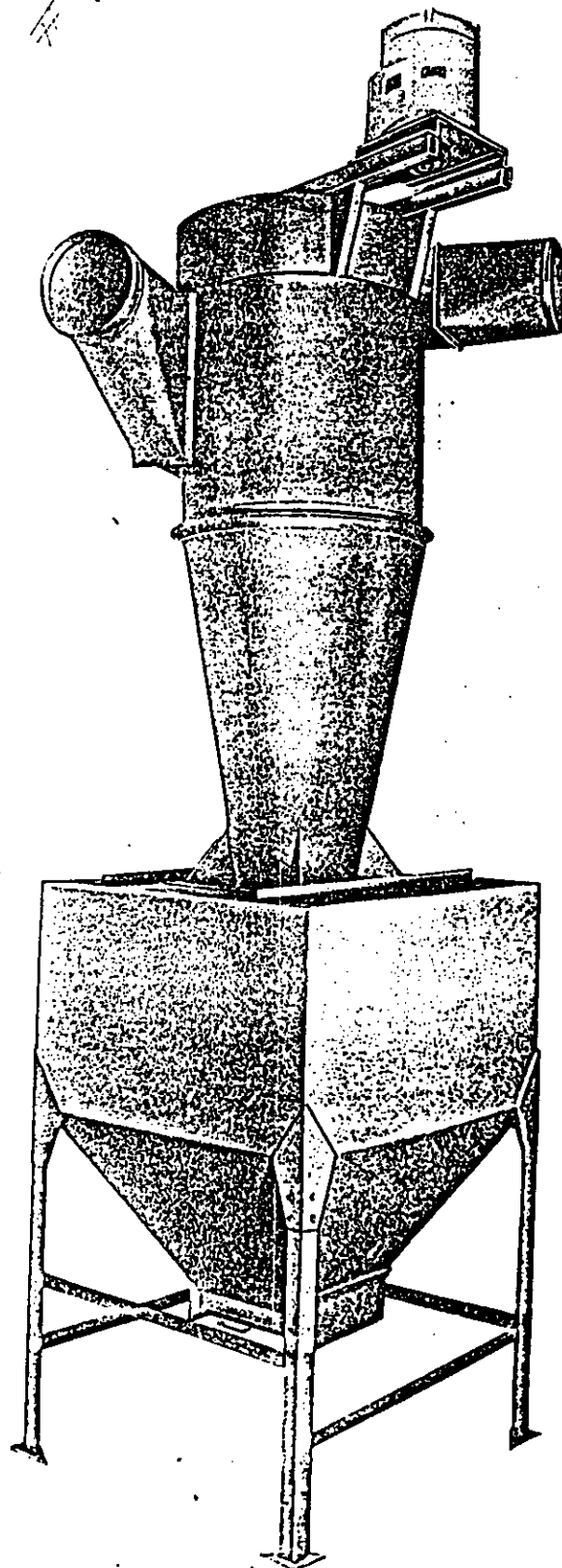



High Efficiency Centrifugal Separators

These ratings cover FM Models — a clean after-filter assembly offers no measurable resistance to airflow. However, resistance will increase during operation — due to dust-loading of filtering media — but can be kept at a minimum by cleaning filter media on a regular maintenance schedule.

Performance ratings and A-scale sound level readings are available on all TORIT collectors. Ratings are read and verified under standard test conditions in TORIT's laboratories.

MODEL	C.F.M.	INLET VELOCITY (12" DIA.) (FPM)	OUTLET VELOCITY (12" DIA.) (FPM)	EXTERNAL STATIC PRESSURE (Inches W.G.)
30 Series	5600	7140	5230	4.9"
30-15	5200	6625	4860	6.3"
	4800	6110	4380	7.9"
	4400	5600	4110	9.5"
	4000	5100	3740	11"
30-10 Series	4500	5732	4205	5.0"
	4000	5095	3738	6.7"
	3500	4458	3271	8.4"
	3000	3821	2804	9.9"

MODEL 30

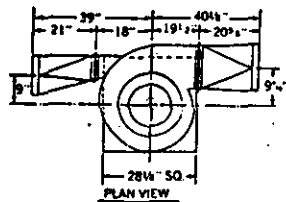

FOR REMOVAL OF MOTOR & FAN WHEEL ASSY. 5" ADDITIONAL HEAD ROOM REQUIRED

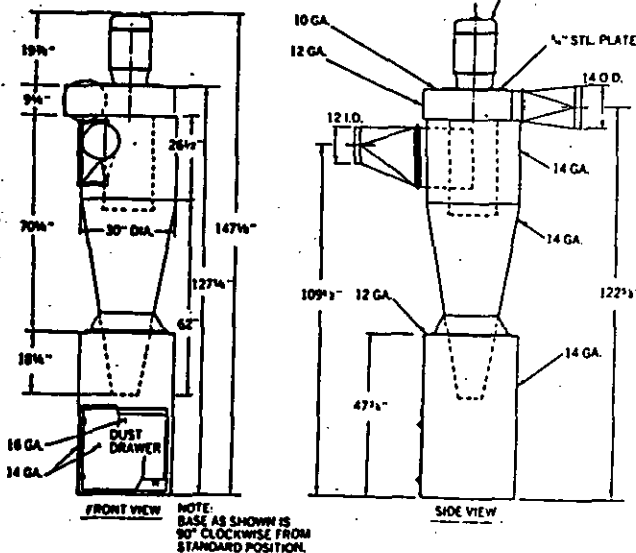

NOTE: BASE AS SHOWN IS 90° CLOCKWISE FROM STANDARD POSITION.

5 inches additional headroom required for assembly or removal of motor and fan wheel. Height shown (including motor) is maximum. For special requirements check with factory.

MODEL 30 FM MODEL 30 FB

Dust storage capacity	8.5 cu. ft.	8.5 cu. ft.
Motor	Model 30-10 includes 10 horsepower, 3600 rpm, 230-460/60/3 phase vertical motor; Model 30-15 includes 15 horsepower, 3600 rpm, 230-460/60/3 phase vertical motor. (specify voltage when ordering)	
Inlet diameter	12 inches	12 inches
Outlet diameter	14 inches	14 inches
Shipping weight	1210 lbs. (Model 30-15) 1175 lbs. (Model 30-10)	1420 lbs. (Model 30-15) 1386 lbs. (Model 30-10)

55-gallon drum stand will increase overall height by 12 inches.

Specifications subject to change without notice

TORIT district sales representatives are conveniently located throughout the United States and Canada. One will gladly work with you on your in-plant air pollution problems, and offer complete recommendations at no obligation to you. Check your Yellow Pages, under "Dust Collecting Systems", for local listing, or write.

LEADERS IN CONTROL OF IN-PLANT AIR POLLUTION

donaldson



Donaldson Company Inc.
Torit Division
Box 1299
Minneapolis, Minnesota 55440

Phone (612) 887-3921
Telex 291038



SERIES 44

High Efficiency Centrifugal Separators

Ratings at right cover FM Models — a clean after-filter assembly offers no measurable resistance to airflow. However, resistance will increase during operations — due to dust loading of filtering media — but can be kept to a minimum by cleaning filtering media on a regular maintenance schedule.

PERFORMANCE GUARANTEE —

Performance ratings are read and verified under standard test conditions in TORIT's laboratories. Performance of all TORIT installations, when equipment is operated according to our recommendation, is guaranteed to be satisfactory.

MODEL 44	CFM	EXTERNAL STATIC PRESSURE	VELOCITIES		
			18" INLET	20" OUTLET	
50 HP	13000	7.0	7357	5969	
	12500	8.6	7074	5730	
	12000	10.0	6791	5500	
	2352	11.4	6508	5271	
	FAN	11000	12.6	6225	5042
	R.P.M.	10500	13.8	5942	4813
40 HP	10000	15.0	5659	4584	
	9500	16.0	5376	4355	
	9000	17.0	5093	4125	
	8500	18.0	4810	3896	
	8000	18.8	4527	3667	
	11500	5.5	6508	5271	
	11000	7.2	6225	5042	
	10500	8.7	5942	4813	
2180	10000	10.0	5659	4584	
FAN	9500	11.5	5376	4355	
R.P.M.	9000	12.8	5093	4125	
	8500	14.0	4810	3896	
	8000	15.1	4527	3667	

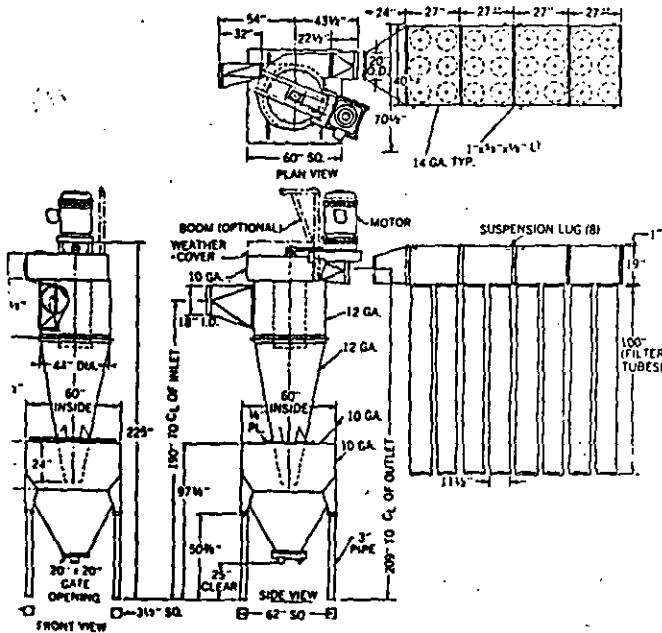

	MODEL 44FM	MODEL 44FB
Dust Storage Capacity	103 cu. ft.	103 cu. ft.
Motor	50 horsepower, 3450 rpm, 230-460v/60/3 vertical motor (specify voltage when ordering).	
Inlet Diameter	18 inches	18 inches
Outlet Diameter	20 inches	20 inches
Height (Exclusive of motor)	225 inches	225 inches
Motor Height	will vary from 23 inches to 32 inches depending on motor type.	
Floor Space	60 x 60 inches	60 x 136 inches
Shipping Weight	3150 lbs.	3750 lbs.

FB models are supplied with an after-filter section of twenty-four 100" filter tubes. TORIT district sales representatives are located

conveniently throughout the nation. One will gladly visit you, study your problem, and make complete recommendations at no obligation to you. Write today.



APR 3 '89 11:21 SEA RAY BOATS, INC.

EXHIBIT "D" PART 3

PROPOSAL
FOR
BAG FILTERATION SYSTEM

Sea Ray Boats Inc.
100 Sea Ray Blvd.
Merritt Island, Fl., 32953

JOE HILL SHEET METAL CO.

P. O. Box 6333 -- Knoxville, Tennessee 37914

615/525-1690

SERVING SOUTHEAST SINCE 1958

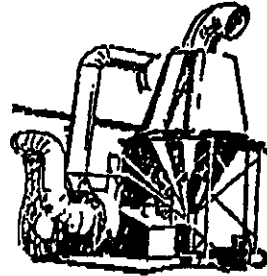
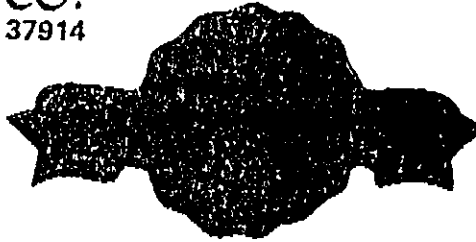

Sea Ray Boats
100 Sea Ray Blvd.
Merritt Island, Florida 32953

March 27, 1989
Quote No.: (Revised) B-2189
ATTN: Greg Crowder
407/452-6710

SUBJECT: PNEUMAFIL BAG FILTRATION SYSTEM

Dear Greg:

The following specifications and proposal are submitted for the fabrication and installation of a Pneumafil Bag Filtration System. One 26"Ø diameter exhaust fan with 75 HP motor will convey sawdust through tapered blow pipe lines into Pneumafil collector. The collector will discharge sawdust into an existing dumpster.

EQUIPMENT

- (1) Pneumafil walk-in dust filter
Size 8.5-162-10 with standard equipment, including 3 HP blower motor
¼ HP motor drive
reverse air cleaning plenum
clean air access door
particle deflector
dust discharge access door
damage limiting panels and sprinkler heads
- (1) One standard maintenance platform with access ladder and safety cage
- (1) Structural support stand for pneumafil filter
- (1) 12" rotary air lock discharge valve w/2HP motor
- (1) Twin City industrial material handling blower, 926-RBR 19,500 CFM with 75 HP Lincoln motor, 230/460/3/60 with Browning belts, drives, motor slide base, belt guard and outlet square to round.

All of the equipment described in this proposal (B-2189) is to be delivered and installed with the understanding that Sea Ray Boats will furnish all electrical wiring, starters, controls, all concrete pads, sprinkler work, receive and store material shipments, furnish a fire watch and fire extinguishing equipment during periods of welding and/or acetylene cutting.

sea ray boats

page 2 of 3 pages

All blow pipe will be fabricated in accordance with the following table as suggested in the American Conference of Governmental Industrialists Higenienists Manual.

<u>DIAMETER OF STRAIGHT DUCT</u>	<u>U.S. STD. GAUGE FOR STEEL DUCT</u>
Up to 8"	24 Ga. Galv.
Over 8" to 15 Ø	20 " "
Over 16" to 24" Ø	18 " "
Over 24" to 30" Ø	16 " "
Over 30" Ø	14 " "

All of the blow pipe described in this proposal (B-2189) will be welded with all welds cleaned and painted.

All elbows will be minimum two gauges heavier than straight pipe lengths of equal diameter.

All tee's to enter trunk line at 30 degree angle.

All supporters for piping will be angle iron steel with cross bracing.

All dust hoods, manifolds, and flexible hoses are not included in this proposal and will be considered extra. We will furnish these on a time and material basis.

* Total Air Filtered by Penumafil	20,080 CFM
Number of Bags	162
Filter length	10 ft.
Filter diameter	8.5 ft.
Filter weight	11,750 lbs.
Cloth filter area	2,085 sq. ft.
Air to cloth ratio	8.5 to 1 AC

MACHINES TO BE PIPED

(2) Radial arm saws	5" Ø ea.
(1) Gang rip saw	6" Ø
(4) Table saws	5" Ø ea.
(1) Pin router	6" Ø
(1) Edge sander	6" Ø
(1) Chop saw	4" Ø
(6) Disc sanders	4" Ø ea.
(1) Time saver sander	2-6"Ø 1-4"Ø
(2) CNC router	5" Ø ea.
(1) Electric fab shop	6" Ø
(5) Floor sweeps	6" Ø ea.

sea ray boats

page 3 of 3 pages

SEA RAY BOATS TO FURNISH

- (1) All electrical wiring and starters to motors.
- (2) Any necessary concrete pads.
- (3) Any necessary sprinkler protection to new collector.
- (4) Fork lift to assist inside erection.
- (5) All applicable taxes required by the State of Florida.

TOTAL PRICE ----- \$ 64,480.00

ALTERNATE ----- 5,150.00

ALTERNATE Cyclone System (No filteration) ~~38,670.00~~

+ 10,000.00 *electric*
+ 6% *sales tax*

TERMS OF PAYMENT

- 10% upon acceptance
- 50% upon delivery of equipment
- 40% upon completion

WARRANTY

Joe Hill Co. agrees to repair and/or replace any part made by Joe Hill Co. and found to be defective in material and/or workmanship for a period of twelve (12) months after date of completion. All work is to be completed in a workman like manner according to standard practices. Any alteration or deviation from the above specifications involving extra costs will be executed only upon written order and will become an extra charge over and above the proposal. All agreements contingent upon strikes, accidents or delays beyond our control. Owner to carry fire, tornado, builders' risk and other necessary insurance.

DELIVERY

Approximately 6 to 8 weeks after order.

We appreciate the opportunity to quote you and hope to be of service in this regard.

Very truly yours,

JOE HILL COMPANY INC.

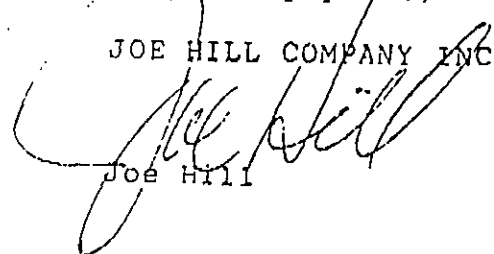

Joe Hill

JH/pb

Accepted by _____

Date _____

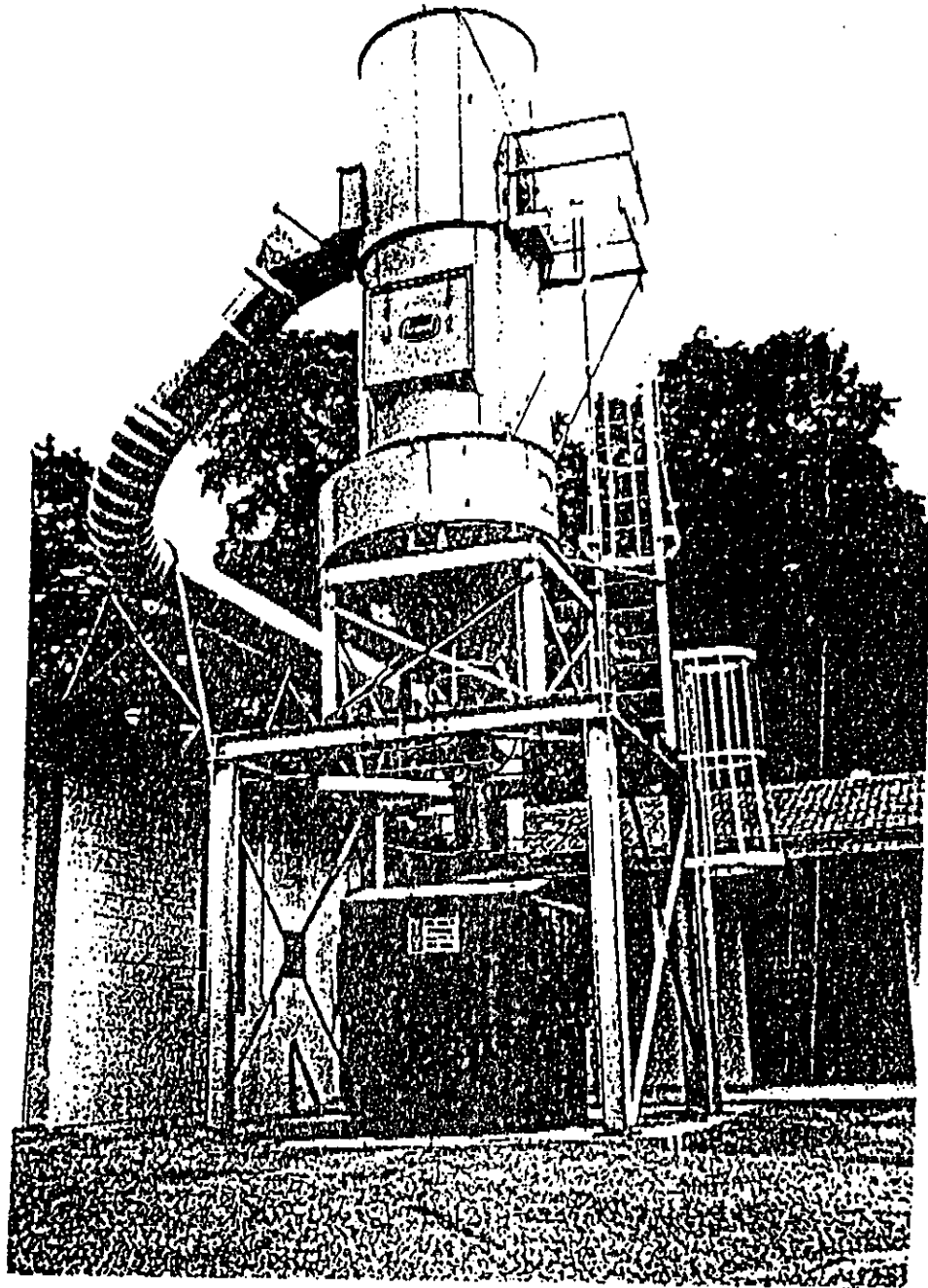

The Pneumafil Reverse Air Filter

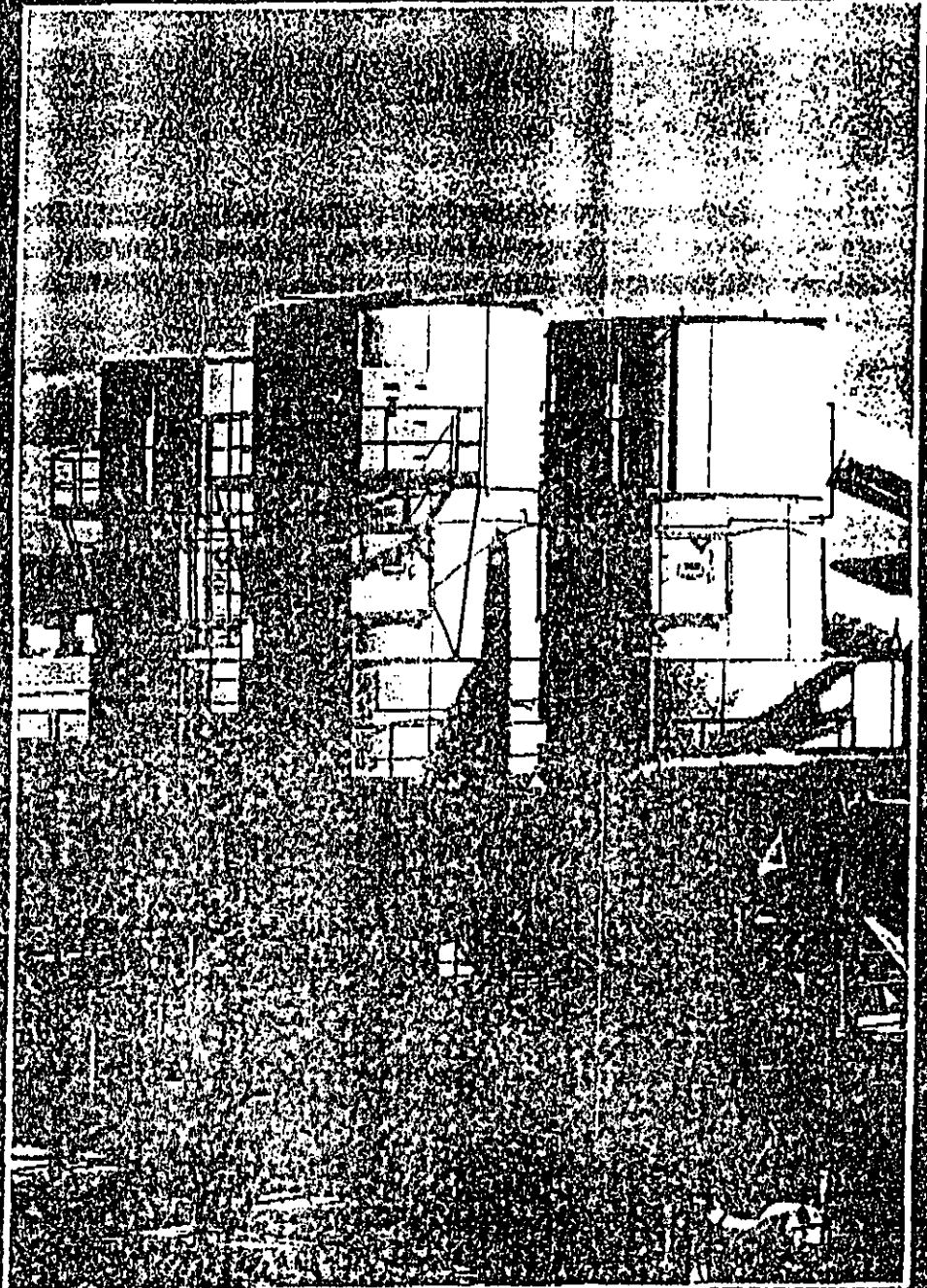

How the filter works

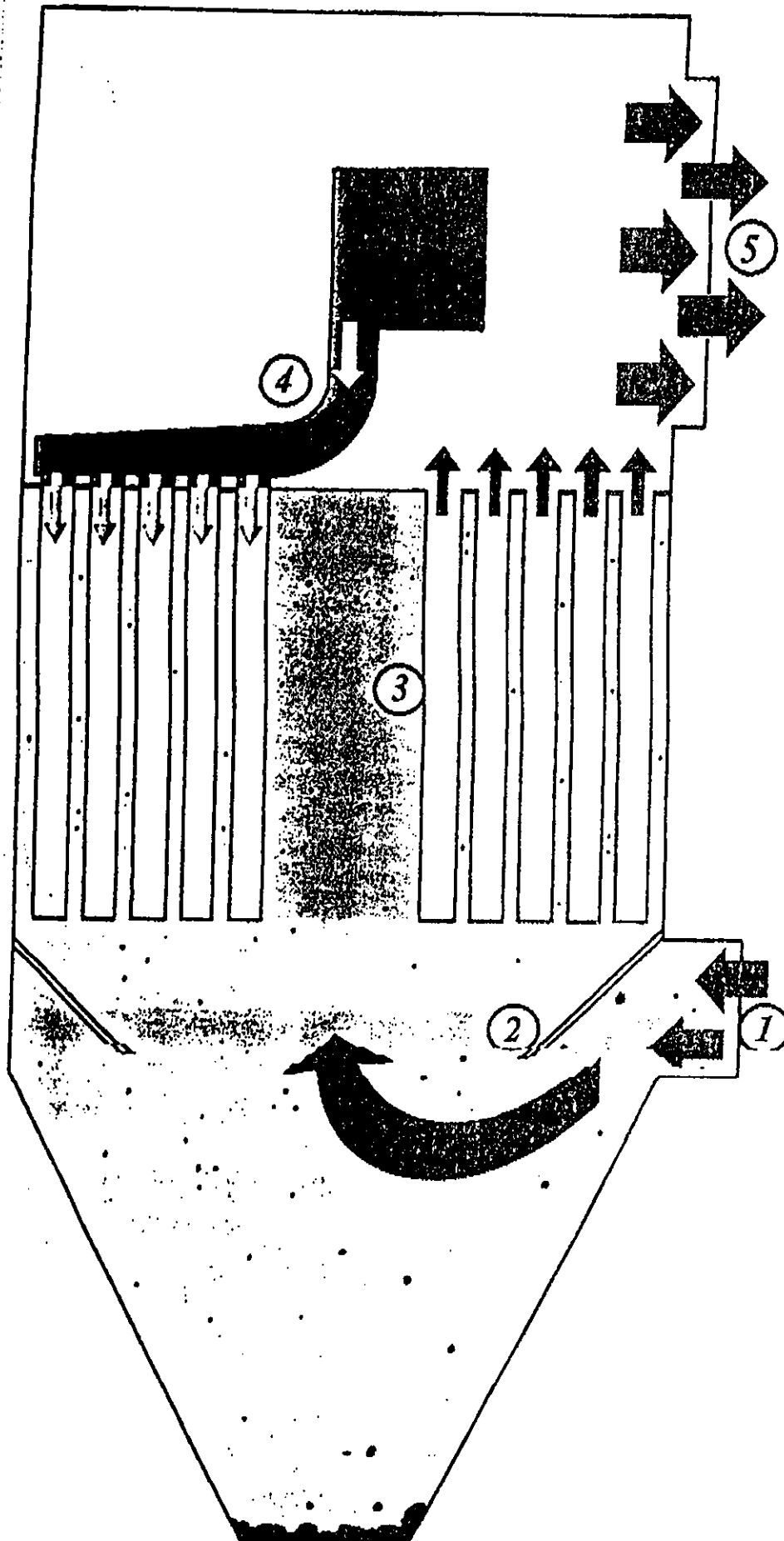

1. Contaminated air enters the Reverse Air Filter through a tangential air inlet. Its large size minimizes entrance pressure loss and reduces power requirements.
2. The combination of the tangential inlet and deep particle deflector results in the cyclonic downward deflection of larger particles to the hopper. This allows heavier loadings, less abrasion to the filter bags, higher collection efficiencies and less energy to remove the remaining particles from the air stream.
3. The filter bags remove dust particles from the air stream. Clean air passes upward through the filter bags and into the walk-in clean air plenum.
4. The reverse-air cleaning fan returns part of the clean air in the walk-in plenum to the rotating air manifold. As the manifold rotates once every minute, clean air is directed to each bag, fresh and warm clean air. Dislodged dust is collected in the conical hopper. Reverse air cleaning of the filter bags maintains constant porosity and low pressure drop across the filter, resulting in an extremely high dust collection efficiency.
5. The clean, dust free air is exhausted through the large air outlet to be either vented to the atmosphere or recycled to the plant. Because of the short contact time required for the air to pass through the Reverse Air Filter, no additional energy is required to either heat or cool the air stream.

The Pneumafil Reverse Air Filter

How it compares . . .

. . . in energy savings

A true evaluation of a dust control system should consider energy consumption as it applies to the complete filter system — and not merely to any one component. This is why all Pneumafil dust filters are designed to function as an integral part of the total system in combination with its other exceptional capabilities for reducing overall operating costs.

For example, our reverse air filters are cleaned by either an economical 7½, 10, or 15 hp motor and costs very little to operate. But more important, each bag is cleaned once every 60 seconds by utilizing the efficient reversed flow of "processed" air. This complete and systematic cleaning dramatically reduces the pressure drop across the media as well as the load demands on the complete fan system. The result is energy savings! Conversely, a system that employs a random air pump cleaning sequence may only require the same amount of horsepower in driving the air pump — however, this type of system *does not* clean the bags every 60 seconds. The air discharge is regulated by when-*ever* and where-*ver* the pressure build up activates the air jets. Because of this random firing, some bags could remain uncleaned indefinitely. This means higher pressure drops across the media, increased demands on the total fan system and ultimately higher energy costs.

Our low tangential air entry utilizes less overall energy than filters with a high air inlet. The low tangential entry allows heavy dust particles to "drop out" into the filter hopper. This initial sorting out of larger dust particles results in greater energy savings and less wear and tear on filter bags. Each contributing to lower operating costs.

Additional energy savings are obtained by recycling plant air previously heated or cooled. With the short contact time of air passing through the filter, the cleaned air is not affected by outside temperatures — and no additional energy is expended to heat or cool make-up air.

. . . with filter maintenance

All bag inspection and removal operations were designed to simplify maintenance procedures and keep maintenance costs down.

With a Pneumafil dust filter, bag inspection can be accomplished without entering the walk-in, clean air plenum viewing port and lighted plenum allows the operator to visually inspect the bag cleaning system from outside filter.

Our walk-in plenum permits top bag removal from clean air side. This operation simply requires extracting two screws before removing and inserting a new bag. Clipping clips on the bag cage eliminates misplacing or dropping into the hopper section.

Pneumafil bags are designed and constructed to deliver maximum efficiency and a consistent high level of performance. Bags are made of 16 oz. polyester felt with a special nylon scrim reinforcement and a 2" canvas wear strip at the bottom to protect against abrasion. All bags can be washed or dry cleaned.

. . . in special features

Tube Sheet

Our filter tube sheet is sectionalized, bolted in place — and in case of damage can be easily removed through the plenum door. Filters that employ welded-in tube sheets require a major dismantling operation. Cutting and welding are required to remove damaged plates, in addition to replacing the entire mechanical section. This can result in considerable downtime and expense.

Wear against the tube sheet is virtually non-existent. The cleaning arm is equipped with a nylon base to eliminate friction of metal to metal contact. A flexible connection permits the arm to ride over obstructions on the tube sheet.

The Pneumafil reverse air bag cleaning operation is accomplished by effectively using a simple reverse flow fan. There are no valves, dampers or compressors to maintain. And with the absence of compressed air, there is less risk of explosion because no additional oxygen is being introduced.

Hopper Design

Our hopper design eliminates the need for any additional and expensive auger discharge. Any bridging of collected dust is prevented by the use of a conical hopper with a 60° slope. Each hopper is equipped with a large, bolted access door and flanged outlets.

... in general construction and painting

The filter is constructed of hot rolled, pickled and oiled mild steel. Our unique standing seam design provides considerable reinforcement and rigidity to the overall structural integrity, making the filter ideally suited for any environment. All filters are constructed to withstand ± 20 in. water gauge.

Each filter is equipped with relief panels in accordance with NFPA standards. The doors are secured with safety chains of uneven lengths to reduce the possibility of the door becoming a projectile. Another example of how Pneumafil pays attention to details.

Every unit is epoxy primed (2.0-2.5 mils) inside and outside and finished outside with polyester epoxy paint (2.0-3.5 mils). Pneumafil offers many standard colors to choose from. Special colors are available to meet customer specifications. Unlike units that have only a single coat of paint, Pneumafil's painting method means additional savings in maintenance costs over the life of the filter. Our paint surface preparation meets the SSPC-SP6 standard and passed a 500 hour salt spray test.

... with options

1. Support structure
2. Three types of maintenance platforms with OSHA approved access ladder
3. Customer color preference
4. Non-sparking air entry wear plates
5. 70° hopper
6. Sprinkler heads
7. Explosion proof motor for Class II-G and F applications
8. Additional bracing for higher pressures
9. Factory insulation
10. High level and high temperature sensors
11. Rotary air locks
12. Modified to customer specifications
13. Special media available

Specification

Notes

1. Standard height from hopper to grade is 4'6". Optional heights are available upon request. Dimensions B, C, D and H change accordingly.
2. Entry section may be rotated 360° except where it would interfere with ladder.
3. Discharge section and ladder may be rotated together 360° in approximately 6" increments except where they would interfere with the entry elbow.
4. Counterclockwise shown, clockwise opposite.
5. Structural supports are designed for 25 P.S.I. when loading and 50 P.C.F. dust loading unless otherwise specified.
6. Filters are available as bin vents.
7. All units have a 360° mounting ring.
8. 4.5' and 5.5' units are not walk-in filters.

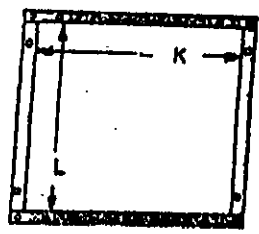
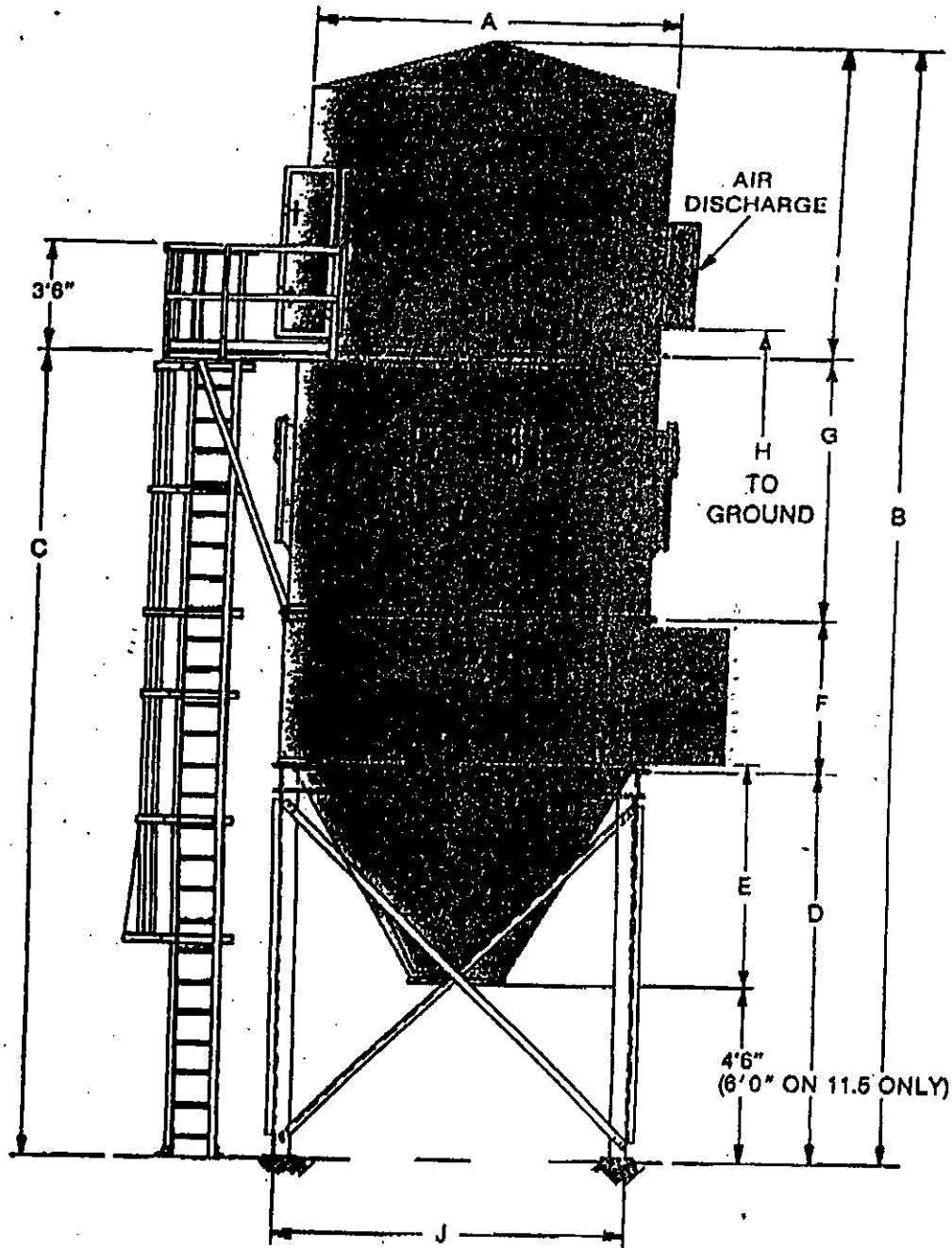

AIR DISCHARGE

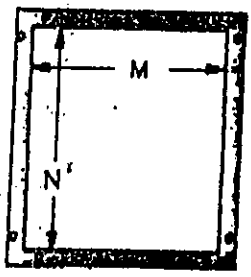

AIR ENTRY

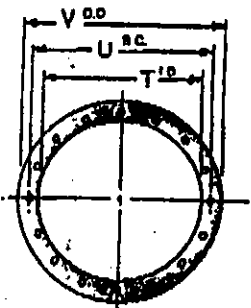

HOPPER OUTLET

MODEL	A	B	C	D	E	F	G	H	I	J	K	L	M	N	U	V	T
4.5-40-8	17'6"	20'5 1/2"	16'3 1/4"	8'3 1/2"	2'1 1/2"	2'1 1/2"	7'1 1/2"	17'3 1/2"	4'2 1/2"	4'4 1/2"	17 1/2"	17 1/2"	17 1/2"	17 1/2"	17 1/2"	17 1/2"	17 1/2"
4.5-40-10	17'6"	22'5 1/2"	18'3 1/4"	8'3 1/2"	2'1 1/2"	2'1 1/2"	7'0 1/2"	19'3 1/2"	4'2 1/2"	4'4 1/2"	17 1/2"	17 1/2"	17 1/2"	17 1/2"	17 1/2"	17 1/2"	17 1/2"
5.5-60-8	17'6"	28'1 1/2"	18'6 1/4"	8'0"	3'0 1/2"	3'0 1/2"	8'0"	20'6 1/2"	4'7 1/2"	5'0"	17 1/2"	17 1/2"	17 1/2"	17 1/2"	17 1/2"	17 1/2"	17 1/2"
5.5-60-10	17'6"	32'0"	21'6 1/4"	8'0"	3'4 1/2"	3'6 1/2"	10'0"	22'5 1/2"	10'7 1/2"	5'8"	17 1/2"	17 1/2"	17 1/2"	17 1/2"	17 1/2"	17 1/2"	17 1/2"
6.5-82-8	17'6"	30'0"	19'6 1/4"	8'0"	3'0 1/2"	3'8 1/2"	8'0"	20'6 1/2"	10'6"	6'4"	17 1/2"	17 1/2"	17 1/2"	17 1/2"	17 1/2"	17 1/2"	17 1/2"
6.5-82-10	17'6"	32'0"	21'6 1/4"	8'0"	3'0 1/2"	3'6 1/2"	10'0"	22'5 1/2"	10'6 1/2"	6'4"	17 1/2"	17 1/2"	17 1/2"	17 1/2"	17 1/2"	17 1/2"	17 1/2"
8.5-158-8	17'6"	31'8 1/2"	21'3 1/4"	8'6 1/2"	5'6 1/2"	3'6"	8'0"	22'4 1/2"	10'8"	8'3 1/2"	17 1/2"	17 1/2"	17 1/2"	17 1/2"	17 1/2"	17 1/2"	17 1/2"
8.5-158-10	17'6"	33'8 1/2"	23'3 1/4"	8'6 1/2"	5'6 1/2"	3'6"	10'0"	24 1/2"	10'6"	8'3 1/2"	17 1/2"	17 1/2"	17 1/2"	17 1/2"	17 1/2"	17 1/2"	17 1/2"
8.5-158-12	17'6"	37'8 1/2"	25'3 1/4"	8'6 1/2"	5'6 1/2"	3'6"	12'0"	26 1/2"	12'6 1/2"	8'6 1/2"	17 1/2"	17 1/2"	17 1/2"	17 1/2"	17 1/2"	17 1/2"	17 1/2"
10.5-258-8	10'8"	37'0"	28'6 1/4"	11'0"	7'3 1/2"	5'0 1/2"	10'0"	28 1/2"	10'6"	10'3"	17 1/2"	17 1/2"	17 1/2"	17 1/2"	17 1/2"	17 1/2"	17 1/2"
10.5-258-10	10'8"	37'0"	20'6 1/4"	11'0"	7'3 1/2"	5'0 1/2"	10'0"	28 1/2"	10'0 1/2"	10'3"	17 1/2"	17 1/2"	17 1/2"	17 1/2"	17 1/2"	17 1/2"	17 1/2"
10.5-258-12	10'8"	31'0"	28'6 1/4"	11'0"	7'3 1/2"	5'0 1/2"	12'0"	28 1/2"	12'6 1/2"	10'3"	17 1/2"	17 1/2"	17 1/2"	17 1/2"	17 1/2"	17 1/2"	17 1/2"
11.5-318-8	11'6"	38'0"	28'0 1/4"	13'0 1/2"	7'3 1/2"	5'0 1/2"	10'0"	29 1/2"	10'6 1/2"	11 1/2"	17 1/2"	17 1/2"	17 1/2"	17 1/2"	17 1/2"	17 1/2"	17 1/2"
11.5-318-10	11'6"	38'0"	28'0 1/4"	13'0 1/2"	7'3 1/2"	5'0 1/2"	10'0"	29 1/2"	10'6 1/2"	11 1/2"	17 1/2"	17 1/2"	17 1/2"	17 1/2"	17 1/2"	17 1/2"	17 1/2"
11.5-318-12	11'6"	30'0"	28'0 1/4"	13'0 1/2"	7'3 1/2"	5'0 1/2"	12'0"	29 1/2"	12'6 1/2"	11 1/2"	17 1/2"	17 1/2"	17 1/2"	17 1/2"	17 1/2"	17 1/2"	17 1/2"
13.5-448-8	13'6 1/2"	40'1 1/4"	30'6 1/4"	14'5 1/2"	8'0"	5'0 1/2"	10'0"	30 1/2"	10'6 1/2"	12 1/2"	17 1/2"	17 1/2"	17 1/2"	17 1/2"	17 1/2"	17 1/2"	17 1/2"
13.5-448-10	13'6 1/2"	40'1 1/4"	30'6 1/4"	14'6 1/2"	8'0"	5'0 1/2"	10'0"	30 1/2"	10'6 1/2"	12 1/2"	17 1/2"	17 1/2"	17 1/2"	17 1/2"	17 1/2"	17 1/2"	17 1/2"
18.5-748-12	18'8 1/2"	44'1 1/4"	32'5 1/4"	14'6 1/2"	8'0"	5'0 1/2"	12'0"	32 1/2"	12'6 1/2"	12 1/2"	17 1/2"	17 1/2"	17 1/2"	17 1/2"	17 1/2"	17 1/2"	17 1/2"

Model dimensions are nominal only. Please consult factory if exact specifications are required.

Pneumafil's unique construction features

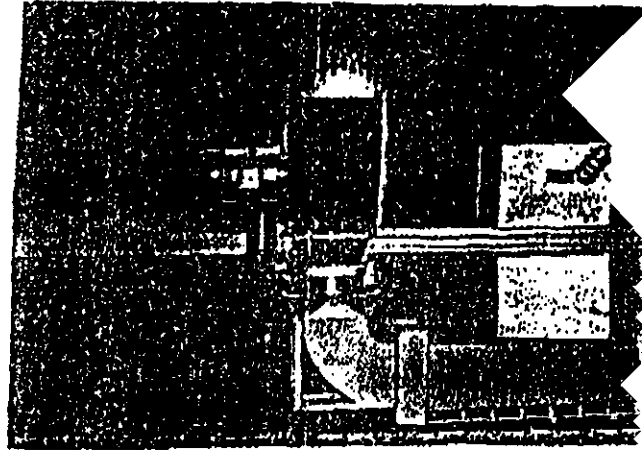

There are distinctive design features about a Pneumafil Reverse Air Filter that sets it apart from other filters. These features translate to direct benefits making a strong case for selecting Pneumafil.

Pneumafil is dedicated to manufacturing a superior product for their customers by using the very best materials, exercising the highest standards in workmanship and employing the latest in applied technology. This dedication is reflected in our attention to details, simplicity of construction and economical cost of operation.

1. Walk-in clean air compartment for inspection maintenance and filter bag changing.
2. Reverse air bag cleaning mechanism with rotating air manifold arm; simple design for trouble-free operation.
3. Fabric filter bags — 16 oz. polyester felt, nylon scrim reinforcement with 2" canvas wear strips on bottom for long life and abrasion resistance.
4. Bolt-in sectional tube sheet for easy replacement.
5. Large, low tangential air inlet for lower pressure drop and cyclonic cleaning action.
6. Built-in particle deflector for abrasion protection of filter bags; thus longer bag life and lower maintenance.
7. Large clean air outlet for lower pressure drop resulting in energy savings.
8. Support steel, ladder and access platform conforms to all applicable building codes.
9. 60° conical hopper for dust collection.
10. Relief panels for safety.
11. Hot rolled, pickled and oiled mild steel with a unique surface preparation for superior corrosive resistant finish, insuring longer filter life and substantial maintenance savings. (Meets SSPC-SP6 standard)
12. Epoxy primed interior and exterior (2.0-2.5 mils), polyester epoxy painted exterior (2.0-3.5 mils). Total paint finish of 4.0-5.5 mils passed 500 hour salt spray test.
13. Components factory assembled and tested.
14. All filters meet EPA and OSHA regulations.
15. Filters constructed to withstand $\pm 20"$ W.G.
16. Standing seams for increased strength.
17. Highest quality control standards in the industry.

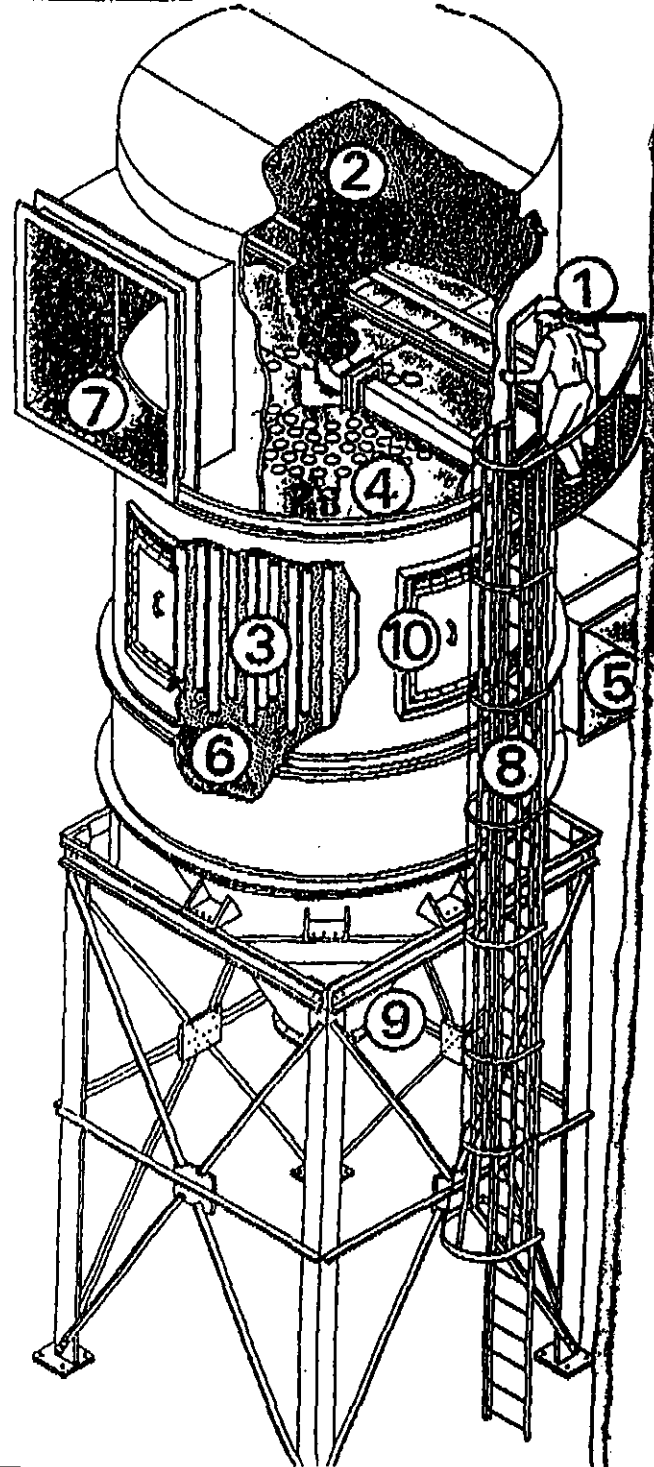

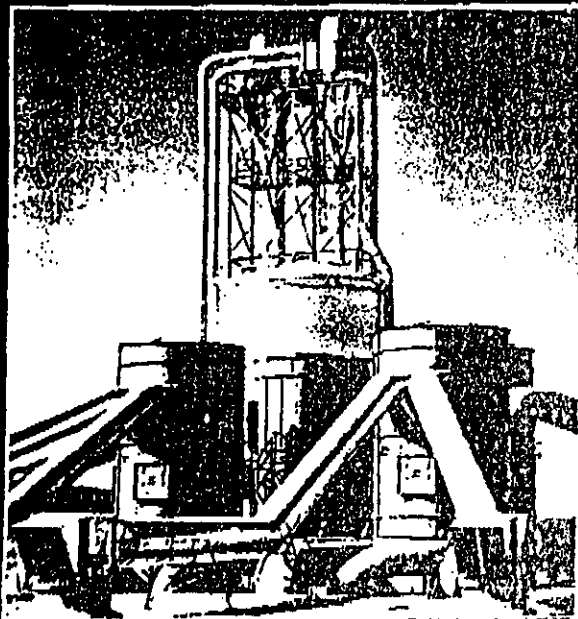
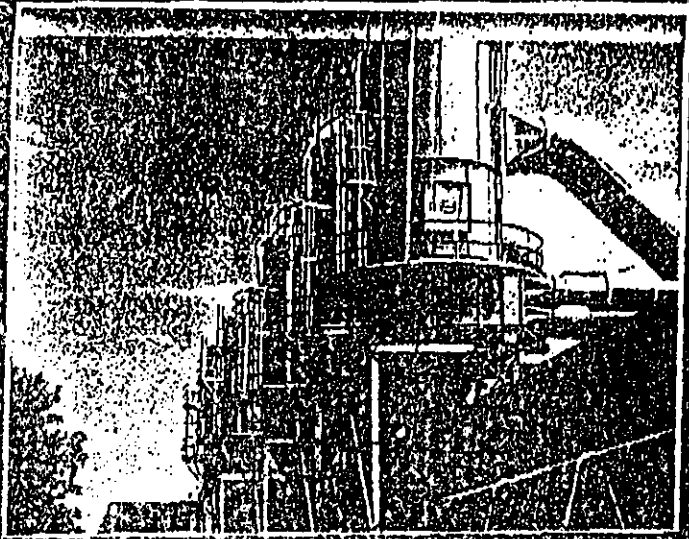
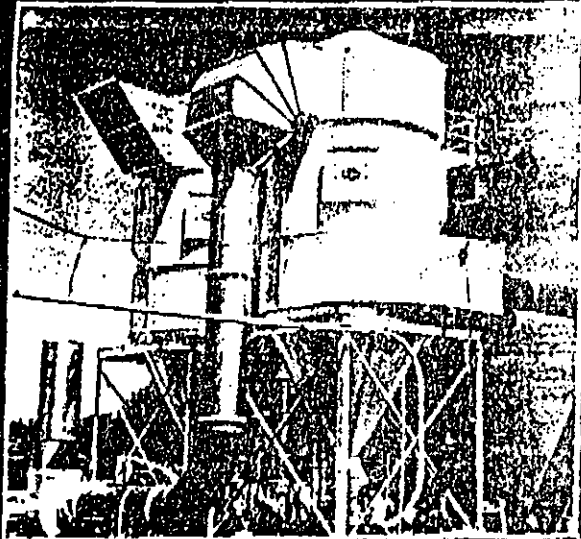

- | | |
|------------------------|-----------------------|
| AMAX Coal Co. | General Mills |
| Archer Daniels Midland | Georgia Pacific |
| Broyhill Industries | International Paper |
| Burlington Furniture | Kingsford Charcoal |
| Carolina Power & Light | Northern States Power |
| Cargill | Pillsbury Company |
| Continental Grain | St. Regis Paper |
| General Electric | |



PNEUMAFIL CORPORATION
 Industrial Air Filters Division
 P.O. Box 16348
 Charlotte, NC 28297-6348
 Tel: 704/393-7431
 Telex: 8106210525

Associated to Air Systems, a Division of the Alfa Group