

RECEIVED

AUG 21 2002

BUREAU OF AIR REGULATION

**TITLE V PERMIT APPLICATION
FLORIDA POWER & LIGHT COMPANY
SANFORD POWER PLANT - UNIT 5
DEBARY, FLORIDA**

**1270009-007-AV
1270009-008-AC / PSD-FL-270(A)**

**Prepared For:
Florida Power & Light Company
700 Universe Boulevard
Juno Beach, Florida 33408**

**Prepared By:
Golder Associates Inc.
6241 NW 23rd Street, Suite 500
Gainesville, Florida 32653-1500**

**August 2002
0237560**

DISTRIBUTION:

**4 Copies - FDEP Bureau of Air Regulation
1 Copy - FDEP Central District
1 Copy - Florida Power & Light Company
1 Copy - Florida Power & Light Sanford Power Plant
1 Copy - Golder Associates Inc.**

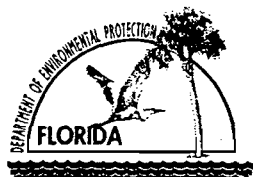

Department of Environmental Protection

Division of Air Resources Management

APPLICATION FOR AIR PERMIT - TITLE V SOURCE

See Instructions for Form No. 62-210.900(1)

I. APPLICATION INFORMATION

RECEIVED

AUG 21 2002

BUREAU OF AIR REGULATION

Identification of Facility

1. Facility Owner/Company Name: Florida Power and Light Company	
2. Site Name: Sanford Plant	
3. Facility Identification Number: 1270009 [] Unknown	
4. Facility Location: Street Address or Other Locator: 950 South Highway 17-92 City: DeBary County: Volusia Zip Code: 32713	
5. Relocatable Facility? [] Yes [X] No	6. Existing Permitted Facility? [X] Yes [] No

Application Contact

1. Name and Title of Application Contact: Mary Archer, Principal Environmental Specialist	
2. Application Contact Mailing Address: Organization/Firm: FPL Environmental Services Dept. [JES/JB] Street Address: 700 Universe Blvd. City: Juno Beach State: FL Zip Code: 33408	
3. Application Contact Telephone Numbers: Telephone: (561) 691-7057 Fax: (561) 691-7070 or 691-7049	

Application Processing Information (DEP Use)

1. Date of Receipt of Application:	
2. Permit Number:	
3. PSD Number (if applicable):	
4. Siting Number (if applicable):	

Purpose of Application

Air Operation Permit Application

This Application for Air Permit is submitted to obtain: (Check one)

- Initial Title V air operation permit for an existing facility which is classified as a Title V source.
- Initial Title V air operation permit for a facility which, upon start up of one or more newly constructed or modified emissions units addressed in this application, would become classified as a Title V source.

Current construction permit number: _____

- Title V air operation permit revision to address one or more newly constructed or modified emissions units addressed in this application.

Current construction permit number: 1270009-004-AC

Operation permit number to be revised: 1270009-001-AV

- Title V air operation permit revision or administrative correction to address one or more proposed new or modified emissions units and to be processed concurrently with the air construction permit application. (Also check Air Construction Permit Application below.)

Operation permit number to be revised/corrected: _____

- Title V air operation permit revision for reasons other than construction or modification of an emissions unit. Give reason for the revision; e.g., to comply with a new applicable requirement or to request approval of an "Early Reductions" proposal.

Operation permit number to be revised: _____

Reason for revision: _____

Air Construction Permit Application

This Application for Air Permit is submitted to obtain: (Check one)

- Air construction permit to construct or modify one or more emissions units.
- Air construction permit to make federally enforceable an assumed restriction on the potential emissions of one or more existing, permitted emissions units.
- Air construction permit for one or more existing, but unpermitted, emissions units.

Owner/Authorized Representative or Responsible Official

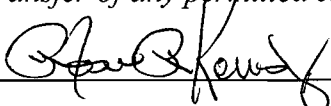
1. Name and Title of Owner/Authorized Representative or Responsible Official: Roxane Kennedy, Plant General Manager
2. Owner/Authorized Representative or Responsible Official Mailing Address: Organization/Firm: FPL Sanford Plant Street Address: 950 South Highway 17-92 City: DeBary State: FL Zip Code: 32713
3. Owner/Authorized Representative or Responsible Official Telephone Numbers: Telephone: (386) 575-5211 Fax: (386) 575-5233
4. Owner/Authorized Representative or Responsible Official Statement: <i>I, the undersigned, am the owner or authorized representative*(check here [], if so) or the responsible official (check here [X], if so) of the Title V source addressed in this application, whichever is applicable. I hereby certify, based on information and belief formed after reasonable inquiry, that the statements made in this application are true, accurate and complete and that, to the best of my knowledge, any estimates of emissions reported in this application are based upon reasonable techniques for calculating emissions. The air pollutant emissions units and air pollution control equipment described in this application will be operated and maintained so as to comply with all applicable standards for control of air pollutant emissions found in the statutes of the State of Florida and rules of the Department of Environmental Protection and revisions thereof. I understand that a permit, if granted by the Department, cannot be transferred without authorization from the Department, and I will promptly notify the Department upon sale or legal transfer of any permitted emissions unit.</i> Signature <u></u> Date <u>8/19/02</u>

* Attach letter of authorization if not currently on file.

Professional Engineer Certification

1. Professional Engineer Name: Kennard F. Kosky Registration Number: 14966
2. Professional Engineer Mailing Address: Organization/Firm: Golder Associates Inc.* Street Address: 6241 NW 23rd Street, Suite 500 City: Gainesville State: FL Zip Code: 32653-1500
3. Professional Engineer Telephone Numbers: Telephone: (352) 336 - 5600 Fax: (352) 336 - 6603

*Cert. of Authorization # 00001670

4. Professional Engineer Statement:

I, the undersigned, hereby certify, except as particularly noted herein, that:*

(1) To the best of my knowledge, there is reasonable assurance that the air pollutant emissions unit(s) and the air pollution control equipment described in this Application for Air Permit, when properly operated and maintained, will comply with all applicable standards for control of air pollutant emissions found in the Florida Statutes and rules of the Department of Environmental Protection; and

(2) To the best of my knowledge, any emission estimates reported or relied on in this application are true, accurate, and complete and are either based upon reasonable techniques available for calculating emissions or, for emission estimates of hazardous air pollutants not regulated for an emissions unit addressed in this application, based solely upon the materials, information and calculations submitted with this application.

If the purpose of this application is to obtain a Title V source air operation permit (check here [X], if so), I further certify that each emissions unit described in this Application for Air Permit, when properly operated and maintained, will comply with the applicable requirements identified in this application to which the unit is subject, except those emissions units for which a compliance schedule is submitted with this application.

If the purpose of this application is to obtain an air construction permit for one or more proposed new or modified emissions units (check here [], if so), I further certify that the engineering features of each such emissions unit described in this application have been designed or examined by me or individuals under my direct supervision and found to be in conformity with sound engineering principles applicable to the control of emissions of the air pollutants characterized in this application.

If the purpose of this application is to obtain an initial air operation permit or operation permit revision for one or more newly constructed or modified emissions units (check here [], if so), I further certify that, with the exception of any changes detailed as part of this application, each such emissions unit has been constructed or modified in substantial accordance with the information given in the corresponding application for air construction permit and with all provisions contained in such permit.

Signature

Date

(seal) 149

Attach any exception to certification statement.

Scope of Application

Emissions Unit ID	Description of Emissions Unit	Permit Type	Processing Fee
009	Combined Cycle Combustion Turbine Generator 5A CT with Heat Recovery Steam Generator		NA
010	Combined Cycle Combustion Turbine Generator 5B CT with Heat Recovery Steam Generator		NA
011	Combined Cycle Combustion Turbine Generator 5C CT with Heat Recovery Steam Generator		NA
012	Combined Cycle Combustion Turbine Generator 5D CT with Heat Recovery Steam Generator		NA
013	Wet Surface Air Cooler - Unit 5		NA

Application Processing Fee

Check one: Attached - Amount: \$: _____ Not Applicable

Construction/Modification Information

1. Description of Proposed Project or Alterations:

2. Projected or Actual Date of Commencement of Construction:

3. Projected Date of Completion of Construction:

Application Comment

Description of overall project:

The steam generating units (Units 4&5) that previously burned residual fuel oil (including provisions for used oil) are being replaced with 8 advanced CTs burning natural gas. The plant configuration will be a combined cycle configuration to include the 8 CTs, and 8 heat recovery steam generators (HRSGs) which will provide steam for the existing steam turbines from Units 4&5. All of the CTs will have an associated fogger as part of the individual units.

The existing steam generating Unit 5 that previously burned residual fuel oil (including provisions for used oil) has been replaced with 4 advanced combustion turbines burning natural gas [and eventually fuel oil]. The current plant addition includes 4 CTs, and 4 HRSGs that provide steam for the existing steam turbine from Unit 5. The Unit 5 boiler has ceased operation as a steam generating unit.

CTs 5A-5D [plus associated HRSGs] are in operation and provide heat to the Unit 5 steam turbine.

Unit 4 steam turbine and CTs 4A through 4D plus the HRSGs are planned for commercial operation in June 2003. The Title V permit will be modified appropriately per regulatory time frames.

Additional Comments:

- Cold start information has been attached to address special considerations for this unit configuration.
- Unit 5 has ceased operation as a steam generating unit.
- The fuel heaters are electric and have no associated emissions.
- The Acid Rain retired unit information is attached for Unit 5.
- The list of insignificant/unregulated equipment has been updated.

II. FACILITY INFORMATION

A. GENERAL FACILITY INFORMATION

Facility Location and Type

1. Facility UTM Coordinates: Zone: 17 East (km): 468.3 North (km): 3190.3			
2. Facility Latitude/Longitude: Latitude (DD/MM/SS): 28 / 50 / 31 Longitude (DD/MM/SS): 81 / 19 / 32			
3. Governmental Facility Code: O	4. Facility Status Code: A	5. Facility Major Group SIC Code: 49	6. Facility SIC(s): 4911
7. Facility Comment (limit to 500 characters): The existing Sanford facility consists of 1 Fossil-Fired Steam Generators (FFSG) and two combined cycle units. FFSG Unit 3 is fired with No. 6 residual fuel oil, No. 2 fuel oil, and natural gas. The FFSG associated with Units 4 & 5 are being replaced with 8 advanced CTs burning natural gas and 8 HRSGs to produce two 4-on-1 combined cycle units. Combined Cycle Unit 5 has commenced operation.			

Facility Contact

1. Name and Title of Facility Contact: Mr. Randy Hopkins, Environmental Specialist			
2. Facility Contact Mailing Address: Organization/Firm: FPL Sanford Plant Street Address: 950 South Highway 17-92 City: DeBary State: FL Zip Code: 32713			
3. Facility Contact Telephone Numbers: Telephone: (386) 575-5385 Fax: (386) 575-5233			

Facility Regulatory Classifications

Check all that apply:

1. <input type="checkbox"/> Small Business Stationary Source?	<input type="checkbox"/> Unknown
2. <input checked="" type="checkbox"/> Major Source of Pollutants Other than Hazardous Air Pollutants (HAPs)?	
3. <input type="checkbox"/> Synthetic Minor Source of Pollutants Other than HAPs?	
4. <input type="checkbox"/> Major Source of Hazardous Air Pollutants (HAPs)?	
5. <input type="checkbox"/> Synthetic Minor Source of HAPs?	
6. <input checked="" type="checkbox"/> One or More Emissions Units Subject to NSPS?	
7. <input type="checkbox"/> One or More Emission Units Subject to NESHAP?	
8. <input type="checkbox"/> Title V Source by EPA Designation?	
9. Facility Regulatory Classifications Comment (limit to 200 characters):	
<p>After the repowering project is complete (June 2003), the facility will not be a major source of HAPs. The new CTs will be subject to NSPS Subpart GG.</p>	

List of Applicable Regulations

Facility emissions covered under existing Title V permit, no additional facility applicable requirements.	

C. FACILITY SUPPLEMENTAL INFORMATION

Supplemental Requirements

1. Area Map Showing Facility Location: <input checked="" type="checkbox"/> Attached, Document ID: <u>Figure C-1</u> [] Not Applicable [] Waiver Requested
2. Facility Plot Plan: <input checked="" type="checkbox"/> Attached, Document ID: <u>Figure C-2</u> [] Not Applicable [] Waiver Requested
3. Process Flow Diagram(s): <input checked="" type="checkbox"/> Attached, Document ID: <u>Figure C-3</u> [] Not Applicable [] Waiver Requested
4. Precautions to Prevent Emissions of Unconfined Particulate Matter: <input checked="" type="checkbox"/> Attached, Document ID: <u>PSNFS_4</u> [] Not Applicable [] Waiver Requested
5. Fugitive Emissions Identification: <input checked="" type="checkbox"/> Attached, Document ID: <u>PSNFS_5</u> [] Not Applicable [] Waiver Requested
6. Supplemental Information for Construction Permit Application: [] Attached, Document ID: _____ [<input checked="" type="checkbox"/>] Not Applicable
7. Supplemental Requirements Comment: <p>The emission units (EUs 009, 010, 011, and 012) associated with Unit 5 are not subject to CAM (40 CFR Part 64), since the emission units do not have a "control device" as defined in Section 64.1. Emission Units 009 through 012 have NO_x CEMs as required by File No. 0710002-008-AC and 40 CFR part 75 and underlying NO_x emissions limits require CEMs.</p>

Additional Supplemental Requirements for Title V Air Operation Permit Applications

8. List of Proposed Insignificant Activities: <input checked="" type="checkbox"/> Attached, Document ID: <u>PSNFS_8</u> <input type="checkbox"/> Not Applicable
9. List of Equipment/Activities Regulated under Title VI: <input type="checkbox"/> Attached, Document ID: _____ <input type="checkbox"/> Equipment/Activities On site but Not Required to be Individually Listed <input checked="" type="checkbox"/> Not Applicable <u>PSNFS_9</u>
10. Alternative Methods of Operation: <input type="checkbox"/> Attached, Document ID: _____ <input checked="" type="checkbox"/> Not Applicable
11. Alternative Modes of Operation (Emissions Trading): <input type="checkbox"/> Attached, Document ID: _____ <input checked="" type="checkbox"/> Not Applicable
12. Identification of Additional Applicable Requirements: <input checked="" type="checkbox"/> Attached, Document ID: <u>PSNFS_12</u> <input type="checkbox"/> Not Applicable
13. Risk Management Plan Verification: <input type="checkbox"/> Plan previously submitted to Chemical Emergency Preparedness and Prevention Office (CEPPO). Verification of submittal attached (Document ID: _____) or previously submitted to DEP (Date and DEP Office: _____) <input type="checkbox"/> Plan to be submitted to CEPPO (Date required: _____) <input checked="" type="checkbox"/> Not Applicable
14. Compliance Report and Plan: <input checked="" type="checkbox"/> Attached, Document ID: <u>PSNFS_14</u> <input type="checkbox"/> Not Applicable
15. Compliance Certification (Hard-copy Required): <input checked="" type="checkbox"/> Attached, Document ID: <u>PSNFS_15</u> <input type="checkbox"/> Not Applicable

FIGURE C-1

AREA MAP SHOWING FACILITY LOCATION

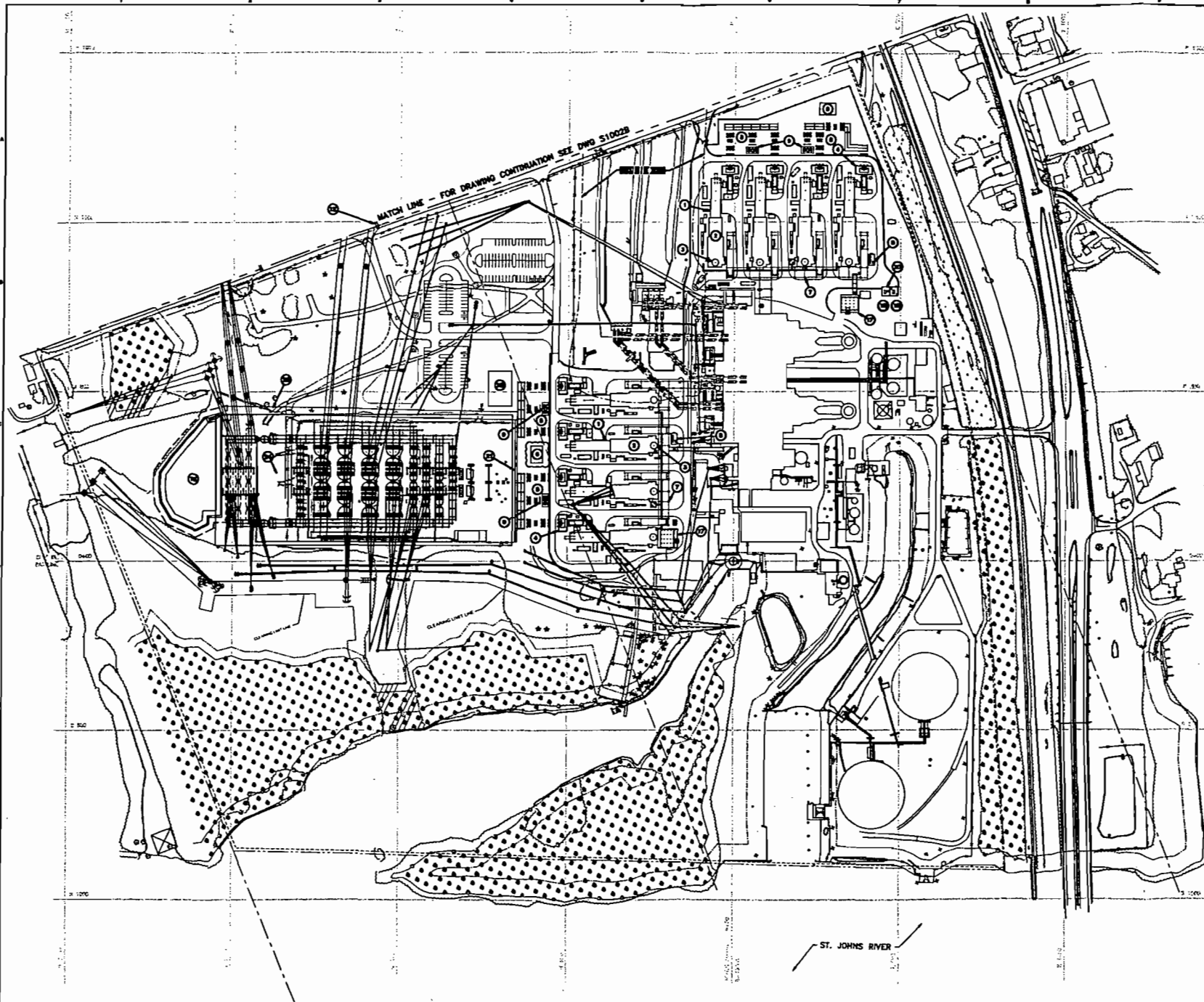

Figure C-1
Area Map Showing Facility Location

Source: Golder, 2001.



FIGURE C-2
FACILITY PLOT PLAN



NEW FACILITY LEGEND

- 1. COMBUSTION TURBINE
- 2. HEAT RECOVERY STEAM GENERATOR (HRSG)
- 3. STACK
- 4. GAS TRANSFORMER
- 5. CT SWITCHBOARD
- 6. CT RELAY VAULT
- 7. PIPE RACK
- 8. SHUNT WINDING
- 9. SHUNT WINDING TRANSFORMER NO. A & B
- 10. NOT USED
- 11. NOT USED
- 12. FRESHWATER CHILLING
- 13. NOT USED
- 14. NOT USED
- 15. NOT USED
- 16. NOT USED
- 17. EVAPORATIVE COOLER
- 18. STORMWATER POND
- 19. FINE MESH STORAGE DAM
- 20. FINE MESH PUMP ENCLOSURE
- 21. STORMWATER CONTROLLED CURB
- 22. BERM
- 23. NOT USED
- 24. TELECOMMUNICATION ENCLOSURE
- 25. MAINTENANCE LADDER AREA
- 26. NOT USED
- 27. NOT USED

NOTES

1. THE COOLING WATER RESERVOIR EXCLUSION ZONE IS MEASURED FROM THE CENTERLINE OF THE BERM AND IS EQUAL TO THE GREATER OF 10 TIMES THE DIFFERENCE BETWEEN THE TOP OF THE BERM ELEVATION AND INSTANT OUNCE OR 20 TIMES THE DIFFERENCE BETWEEN COOLING WATER RESERVOIR SURFACE ELEVATION AND CENTER THE COOLING WATER RESERVOIR NORMAL OPERATION LEVEL IS PLANT ELEVATION 108.81 (ELEVATION PLUS 87 FEET ABOVE MEAN SEA LEVEL). EXERCISE AND HOME ACTIVITIES ARE NOT ALLOWED WITHIN THE EXCLUSION ZONE WITHOUT PRIOR APPROVAL OF THE CONSTRUCTION MANAGER AND DAM SAFETY COORDINATOR.

LEGEND

- PROPERTY LINE
- PROJECT AREA BOUNDARY
- CONSTRUCTION BUFFER FROM BERM/WEIR/DAIRY
- SECTION LINE
- EXISTING FENCED
- NEW FENCED
- WEIR/DAIRY
- CROSSING TRANSMISSION LINE CORRIDOR
- THE BUFFER ZONE
- BERM/DAM

UPDATED ARRANGEMENT

APPROVED FOR CONSTRUCTION

NO.	DATE	DESCRIPTION	BY	CHECKED
1	08-13-2008	GENERAL REVISIONS		
2	03-27-2009	GENERAL REVISIONS		
3	01-13-2009	APPROVED FOR CONSTRUCTION		
4	10-12-08	FINAL ISSUE		
5	08-13-08	ISSUED AND RECORD OF REVISIONS		

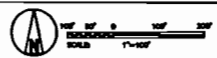

BLACK & VEATCH
 PROJECT NO. 61282-95TU-S1002A
 SHEET NO. 3 OF 3

FLORIDA POWER & LIGHT
 SANFORD REPOWERING PROJECT
 GENERAL-SITE ARRANGEMENT
 SOUTH OF BARRICK ROAD

PROJECT NO. 61282-95TU-S1002A
 SHEET NO. 3 OF 3
 DATE: 08/13/08

FIGURE C-3
PROCESS FLOW DIAGRAM

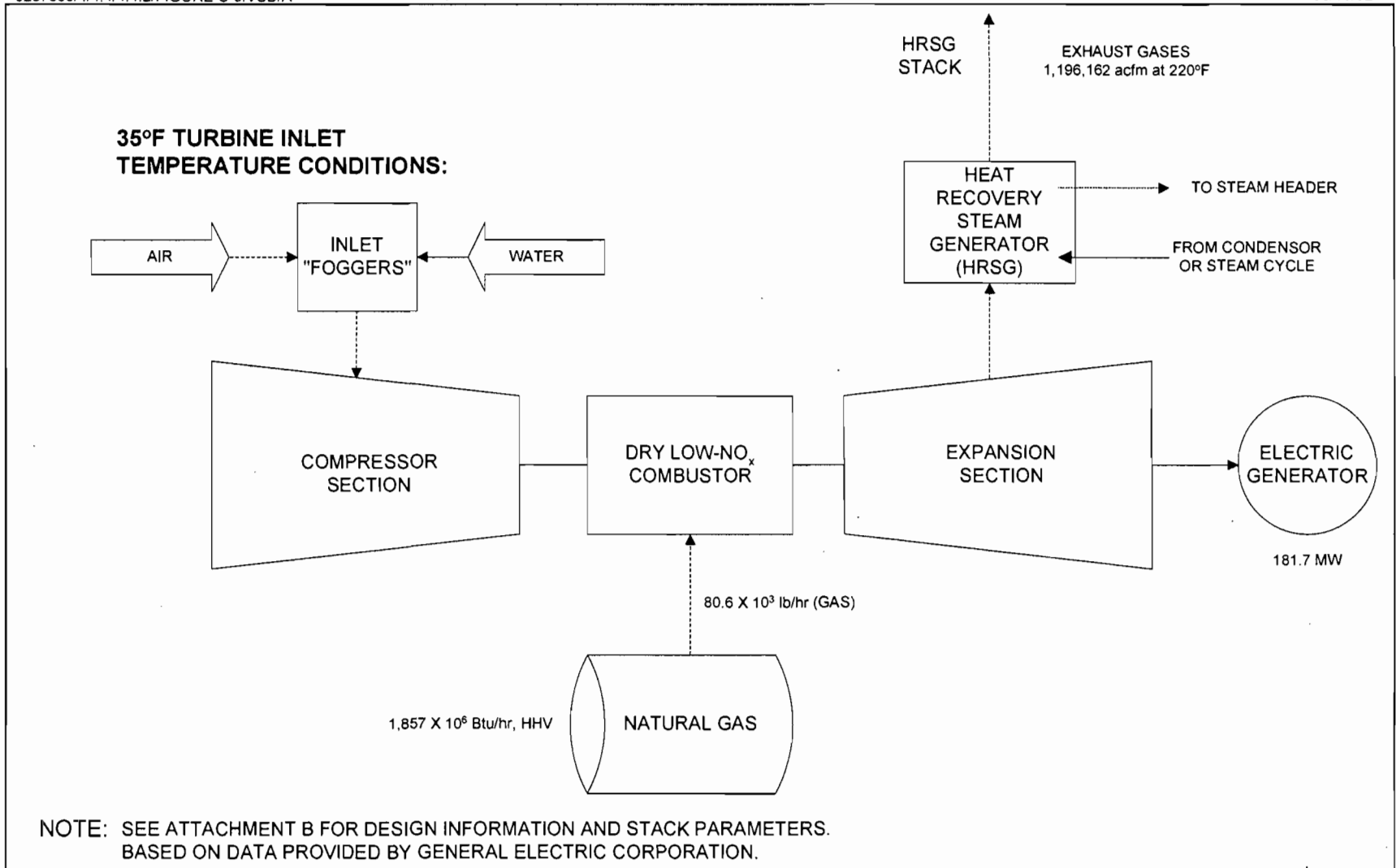

**SANFORD
REPOWERING
PROJECT**

Figure C-3A
Simplified Flow Diagram of Units 5A-5D
Natural Gas Firing
Sanford Repowering Project



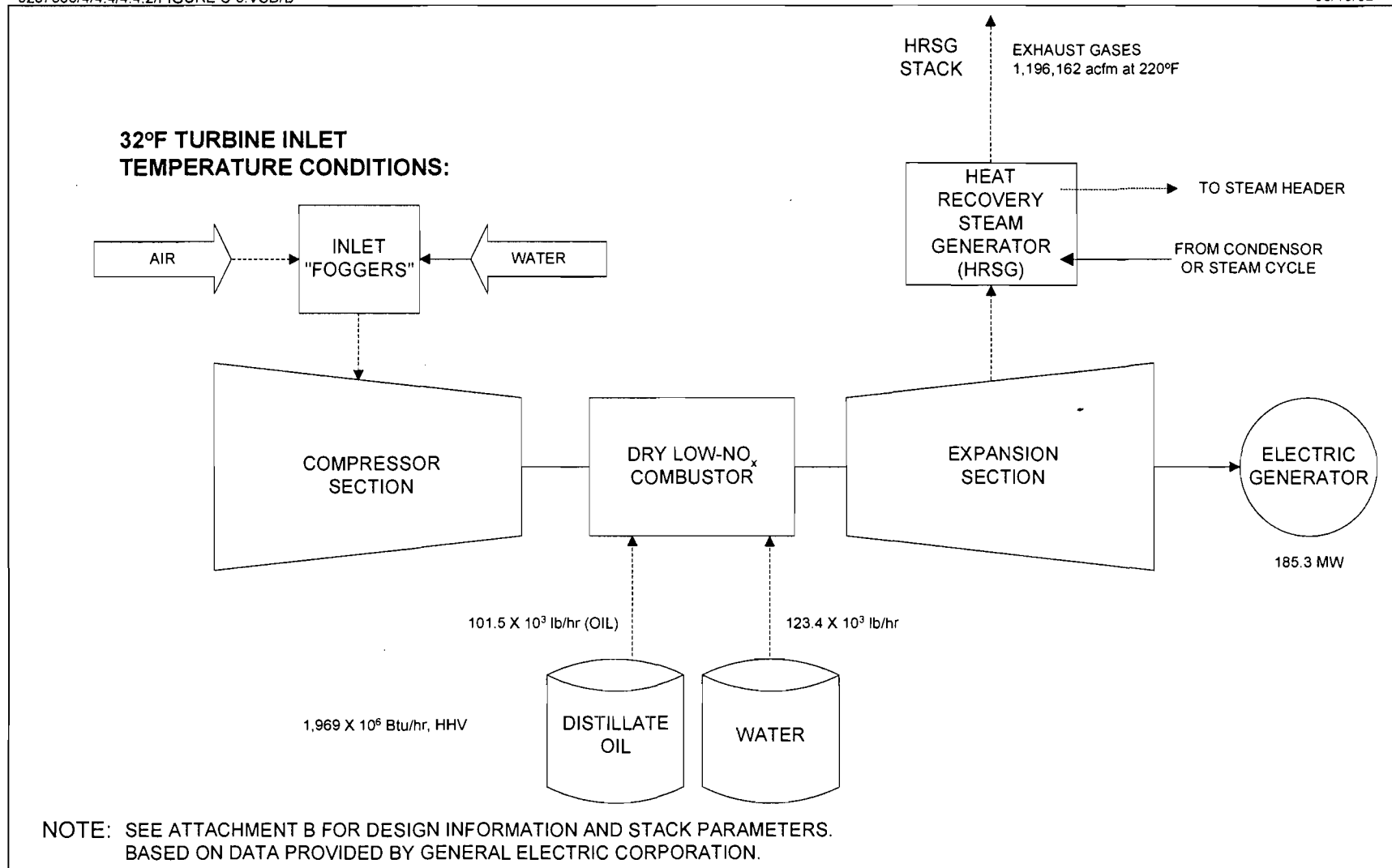

**SANFORD
REPOWERING
PROJECT**

Figure C-3B
Simplified Flow Diagram of Units 5A-5D
Distillate Oil Firing
Sanford Repowering Project



ATTACHMENT PSNFS_4

**PRECAUTIONS TO PREVENT EMISSIONS OF UNCONFINED PARTICULATE
MATTER**

ATTACHMENT PSNFS_4**PRECAUTIONS TO PREVENT EMISSIONS OF UNCONFINED PARTICULATE MATTER
ASSOCIATED WITH UNIT 5**

The facility has negligible amounts of unconfined particulate matter (PM) as a result of the operation of the facility. Potential examples of PM include:

- Fugitive dust from unpaved roads,
- Sandblasting abrasive material from plant maintenance activities, and
- Fugitive particulates from the use of bagged chemical products (soda ash, di-, tri- and monosodium phosphate, and other chemicals as needed).

Several precautions were taken to prevent emissions of PM in the *original design* of the facility. These include:

- Paving of roads, parking areas and equipment yards; and
- Landscaping and planting of vegetation.

Operational measures are undertaken at the facility, which also minimize particulate emissions, in accordance with 17-296.310 F.A.C.:

- The facility uses temporary sandblasting enclosures when necessary to perform sandblasting on fixed plant equipment.
- Maintenance of paved areas as needed.
- Regular mowing of grass and care of vegetation.
- Limiting access to plant property by unnecessary vehicles.
- Bagged chemical products are stored in weather-tight buildings until they are used. Spills of powdered chemical products are cleaned up as soon as practicable.
- Vehicles are restricted to slow speeds on the plant site.

ATTACHMENT PSNFS_5
FUGITIVE EMISSIONS IDENTIFICATION

ATTACHMENT PSNFS_5**FUGITIVE EMISSIONS IDENTIFICATION - UNIT 5**

Three pollutants are considered as fugitive emissions at the facility: PM, volatile organic compounds (VOC), and total hazardous air pollutants (HAPs). The fugitive PM emissions are comprised of fugitive dust from unpaved roads, sandblasting, the use of bagged chemical products, and are addressed in the previous attachment (Attachment PSNFS_4). The fugitive VOC emissions are comprised of several sources at the facility site, including breathing and working losses for fuel storage tanks, painting, aerosol can usage, solvent use, etc.

It should be noted that many fugitive emissions at the facility can be classified as insignificant activities (below relevant reporting thresholds), and are therefore not included here. The following examples are relevant to this facility:

- Fugitive VOC Emissions from Unit 5, and
- Fugitive HAPs emissions from activities associated with Unit 5.

ATTACHMENT PSNFS_8

LIST OF PROPOSED INSIGNIFICANT ACTIVITIES

ATTACHMENT PSNFS_8

SANFORD UNIT 5 LIST OF UNREGULATED AND INSIGNIFICANT ACTIVITIES

Following are several pages of unregulated and insignificant activities associated with Unit 5. The insignificant activities identified in this application are provided for information only and are identified as examples of, but not limited to, the insignificant activities identified by the Division of Air Resources Management. It is understood that such activities do not have to be included with the Title V Application. The insignificant activities identified herein are consistent, in terms of amounts of emissions and types, with those activities listed in DARM's previous guidance.

Pursuant to Rule 62-210.300(3)(b)1., notice is herein provided that the emissions units listed below are not subject to a permit issued by the Department of Environmental Protection and are exempt from permitting until a final determination is made under the Title V permitting requirements (Rule 62-213 F.A.C.). These units would not have triggered review under Rules 62-212.400 or 62-212.500 or any new source performance standard listed in Rule 62-204.800 F.A.C..

COMBINED CYCLE UNIT 5 ANCILLARY BUILDINGS/AREAS

Miscellaneous Buildings H.V.A.C.

Control Building: Offices, Kitchen, Toilets
 Service Building: Offices, Kitchen, Toilets
 Switchyard Building
 Collector Yard Building
 C.E.M. Buildings (4)
 Laboratory
 Maintenance Building
 Maintenance Lunchroom
 Stores Building

Sanitary Vents/Stacks

Control Building
 Service Building
 Maintenance Building
 Laboratory
 Stores Building
 Port-a-Johns

Miscellaneous Buildings Vent/Exhaust

Systems

Service Building
 Lab Building
 R.O. Building
 Diesel Gen. Bldg
 Switchyard Control Bldg
 Collector Yard Building
 Paint & Lube Oil Storage Bldg
 Warehouses
 Maintenance Building
 Administration Building
 Waste Accumulation and Product Building

Miscellaneous Maintenance Facilities

Air Compressors
 Sandblasting Units
 Non-Halogenated Solvent Cleaning Operations
 Lawn Maintenance Engine Emissions,
 Fertilizers
 Cleaning, Painting, Welding, Coating Hand
 Held Tools & Equipment
 Products Storage in Sealed Containers
 Application of Fungicide; Herbicide & Pesticide
 Vacuum Cleaning, Solvent Storage, Office
 Supplies/Equipment
 Miscellaneous Gasoline & Diesel Engine
 Portable Tools & Equipment
 C.E.M. Building Testing Equipment

Gas Bottle Storage

Nitrogen, Hydrogen, CO2 Cylinders, Cryogenic
 H2 Storage tank Vent

Unpaved Roads

Fugitive Dust

Sumps

Oily Wastewater Separators

Fuel Oil, Light

Tanker Unloading Dock Area Fugitive
 Emissions

Waste Accumulation & Product Storage Area

Sealed Drums & Containers
 Storage Area Asbestos Equipment

**COMBINED CYCLE UNIT 5
COMBUSTION TURBINES**

CT5A through 5D

Fuel Gas Safety
 Fuel Gas Coalescing Filter Vent
 Fuel Gas Coalescing Filter Drain Tank
 Fuel Gas Tube & Shell Heater Safety
 Fuel Gas Tube & Shell Heater Gas Side Drain
 Fuel Gas Tube & Shell Heater Gas Side Vent
 Fuel Gas Tube & Shell Water Side Safety
 Fuel Gas Tube & Shell Water Side Vent
 Fuel Gas CT Control Gas Vent
 Gas Line Drains
 Gas Line Vents
 CO2 Fire Suppression system Drain
 CO2 Fire Suppression system Vent
 CO2 Fire Suppression system discharge points
 in the CT Building
 Water Wash Skid Drain
 Water Wash Collection Tank
 Water Wash Casing drain
 PEECC Building HVAC Drain
 PEECC Building Floor Drain
 Auxiliary Cabinet Explosion diaphragms
 Auxiliary Cabinet water Drains
 Auxiliary Cabinet Oil Drains
 Inlet Duct Drain
 GEC Building HVAC
 GEC Building Floor Drain

**COMBINED CYCLE UNIT 5 HEAT
RECOVERY STEAM GENERATORS**

Primarily Steam and Water Vents/Drains

HRSG 5A through 5D:

High Pressure Drum Safety
 High Pressure Drum Vent
 High Pressure Drum Drain
 High Pressure Intermittent Blowdown
 High Pressure Drum Instrumentation Drains
 Main Steam Safety
 Main Steam Vents
 Main Steam Drains
 High Pressure Feedwater Drain
 High Pressure Economizer Drain
 High Pressure Evaporator Drain
 Intermediate Pressure Drum Safety
 Intermediate Pressure Drum Vent
 Intermediate Pressure Drum Drain
 Intermediate Pressure Intermittent Blowdown
 Intermediate Pressure Instrumentation Drains
 Intermediate Pressure Steam Safety
 Intermediate Pressure Steam Drain
 Intermediate Pressure Steam Vent
 Intermediate Pressure Feedwater Drain
 Intermediate Pressure Economizer Drain
 Intermediate Pressure Evaporator Drain
 Cold Reheat Header Safety
 Cold Reheat Header Drain
 Hot Reheat Header Safety
 Hot Reheat Header Vent
 Hot Reheat Header Drain
 Fuel Gas Feedwater return Drain
 Low Pressure Drum Safety
 Low Pressure Drum Vent
 Low Pressure Drum Drain
 Low Pressure Drum Intermittent Blowdown
 Low Pressure Instrumentation Drains
 Low Pressure Steam Safety
 Low Pressure Steam Vent
 Low Pressure Steam Drain
 Low Pressure Feedwater Drain
 Low Pressure Economizer Drain
 Low Pressure Evaporator Drain
 High Pressure Feedpump Drain
 Process Instrumentation Drains

**COMBINED CYCLE UNIT 5
COMMON PIPING AREA**

Primarily Steam and Feedwater Vent/Drains

Main Steam Lines Drains to Drains Tank
 Hot Reheat Lines Drains to Drains Tank
 Cold Reheat Lines Drains to Drains Tank
 Turbine Area Drains Tank Vent
 Main Steam Lines Drains to Drains Header
 Hot Reheat Lines Drains to Drains Header
 Cold Reheat Lines Drains to Drains Header
 Low Pressure Lines Drains to Drains Header
 HRSG A Drains Header Vent
 HRSG A Blowdown Drains Tank Vent
 HRSG B Drains Header Vent
 HRSG B Blowdown Drains Tank Vent
 HRSG C Drains Header Vent
 HRSG C Blowdown Drains Tank Vent
 HRSG D Drains Header Vent
 HRSG D Blowdown Drains Tank Vent
 HRSG Blowdown Sump Vent
 HRSG Blowdown Sump Drain

**COMBINED CYCLE UNIT 5
COMMON FEEDWATER SYSTEM**

Primarily Steam and Water Vents/Drains

Condensate Storage Tank Drain
 Condensate Storage Tank Vent
 Demineralized Water Tank Vent
 Demineralized Water Tank Drain
 Demineralized Water Supply Pump A Drain
 Demineralized Water Supply Pump B Drain
 Demineralized Water Supply Pump Vent
 Cycle Makeup Tank Vent
 Cycle Makeup Tank Drain
 Cycle Makeup Feedpump A Drain
 Cycle Makeup Feedpump B Drain
 Cycle Makeup Line Vents & Drains
 Condenser 5 Reject Line Drain
 "B" Water Storage Tank Vent NOTE: This is
 the old "B" fuel oil storage tank converted
 "B" Water Storage Tank Drain NOTE: This is
 the old "B" fuel oil storage tank converted

**COMBINED CYCLE UNIT 5
STEAM TURBINE AREAS**

Primarily Steam and Water Vents/Drains

STEAM TURBINE 5

Condenser Drain
 Water Box Inlet Drain A
 Water Box Inlet Drain B
 Water Box Outlet Drain A
 Water Box Outlet Drain B
 Exhaust Hood Rupture Diaphragm A
 Exhaust Hood Rupture Diaphragm B
 Gland Steam Condenser Drain
 Gland Steam Condenser Vent
 Steam Jet Air Ejector Vent
 Steam Jet Air Ejector Drain
 Condenser Vacuum Hogger Vent
 Condenser Vacuum Hogger Drain
 Circulating Water Pump A Vent
 Circulating Water Pump B Vent

ATTACHMENT PSNFS_9

LIST OF EQUIPMENT/ACTIVITIES REGULATED UNDER TITLE VI

ATTACHMENT PSNFS_9**EQUIPMENT/ACTIVITIES REGULATED UNDER TITLE VI**

The Sanford facility currently has no equipment containing more than 50 pounds of CFCs. There are several air conditioning and refrigeration units on the plant site, but these contain less than the threshold quantity of CFCs.

ATTACHMENT PSNFS_12

**IDENTIFICATION OF ADDITIONAL APPLICABLE REQUIREMENTS
SANFORD REPOWERING PROJECT CONSTRUCTION PERMIT**

STATE OF FLORIDA
DEPARTMENT OF ENVIRONMENTAL PROTECTION
NOTICE OF PERMIT

In the Matter of an
Application for Permit by:

Ms. Roxane Kennedy, Plant General Manager
FPL Sanford Plant
950 South Highway 17-92
DeBary, Florida 32713

DEP File No. 1270009-004-AC
PSD-FL-270
2200 MW Gas Repowering Project
Volusia County

Enclosed is the Final Permit Number 1270009-004AC to construct/ install eight (8) combined cycle units and auxiliary equipment to replace two (2) residual oil and gas-fired steam generators at the Sanford Plant near DeBary, Volusia County. The permit also establishes facility-wide emission caps. This permit is issued pursuant to Chapter 403, Florida Statutes.

Any party to this order (permit) has the right to seek judicial review of the permit pursuant to Section 120.68, F.S., by the filing of a Notice of Appeal pursuant to Rule 9.110, Florida Rules of Appellate Procedure, with the Clerk of the Department in the Legal Office; and by filing a copy of the Notice of Appeal accompanied by the applicable filing fees with the appropriate District Court of Appeal. The Notice of Appeal must be filed within 30 (thirty) days from the date this Notice is filed with the Clerk of the Department.

Executed in Tallahassee, Florida.

C.H. Fancy, P.E., Chief
Bureau of Air Regulation

CERTIFICATE OF SERVICE

The undersigned duly designated deputy agency clerk hereby certifies that this NOTICE OF FINAL PERMIT (including the FINAL permit) was sent by certified mail (*) and copies were mailed by U.S. Mail before the close of business on 9-14-99 to the person(s) listed:

Roxane Kennedy, FPL*
Richard Piper, FPL
Len Kozlov, DEP CD
Gregg Worley, EPA
John Bunyak, NPS
Ken Kosky, P.E., Golder Associates
Peter Cunningham, Esq., HGSS

Clerk Stamp

FILING AND ACKNOWLEDGMENT FILED, on this date,
pursuant to §120.52, Florida Statutes, with the designated
Department Clerk, receipt of which is hereby acknowledged.

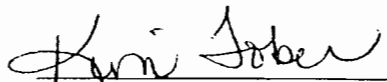
(Clerk) 9-14-99
(Date)

FINAL DETERMINATION
Florida Power & Light Company
Sanford Power Plant
2,200 MW Repowering Project

The Department distributed a public notice package on July 30, 1999 for the project to construct/install eight combined cycle units to replace two (2) residual oil-fired steam boiler generating units at the Florida Power & Light (FPL) Sanford Plant near De Bary, Volusia County. The Public Notice of Intent to Issue was published in the News Journal on August 5, 1999.

No comments were received by the Department from the public, EPA or any other government agency.

Comments were received from FPL by letter and electronic correspondence dated August 17.

FPL commented on the draft permit and on the Technical Evaluation and Preliminary Determination (TEPD). FPL's comments are keyed to the TEPD and draft permit specific conditions contained therein. The Department's responses are included following each comment.

Placard Page:

FPL suggests the following changes in the placard page: "Permit to install eight (8) combined cycle units to replace two (2) residual oil-fired and gas-fired steam boiler generating units. Each combined cycle unit is a 170 megawatt General Electric MS7241FA gas-fired combustion turbine-generator with an unfired heat recovery steam generator (HRSG) that will ~~raise sufficient steam~~ capture sufficient waste heat to produce another 80 MW via the existing steam-driven electrical generators." Change the last sentence to: "The project also includes a helper cooling tower for once-through cooling pond water and small heaters with individual 10-foot stacks to heat the natural gas prior to use during simple-cycle operation and cold start-ups."

The Department agrees with FPL suggestions and made the changes accordingly.

Facility Description:

FPL suggests the following changes: "This permitting action (approximately 2,200MW Repowering Project) is to install eight (8) combined cycle units to replace two (2) residual oil-fired and gas-fired steam generating boiler units; existing steam turbines will remain. Each combined cycle unit is a 170 megawatt General Electric MS7241FA gas-fired combustion turbine-generator with an unfired heat recovery steam generator (HRSG) that will capture ~~raise sufficient steam~~ waste heat to produce another 80 MW via the existing steam-driven electrical generators. The project also includes a helper cooling tower for once-through cooling pond water and small heaters with individual 10-foot stacks to heat the natural gas prior to use during simple cycle operation and cold start-ups."

This Project is exempt from the requirements of Rule 62-212.400, F.A.C., Prevention of Significant Deterioration (PSD) as ~~discussed~~ stated in the Technical Evaluation and Preliminary Determination dated July 30, 1999, for all pollutants except Volatile Organic Compounds (VOC's)."

The Department agrees with FPL suggestions and made the changes accordingly.

Specific Condition 9 Turbine Capacity; Page 7 of 14:

FPL requests the following changes: The ~~maximum~~ design heat input rates for natural gas firing, based on the lower heating value (LHV) of the fuel to each combustion turbine at compressor inlet conditions of 59°F, 60% relative humidity, 100% load, and 14.7 psia ~~is shall not exceed 1,600~~ 1,760 million Btu per hour (MMBtu/hr). The ~~maximum~~ design heat input for oil firing ~~is 1,820~~ 2002 MMBtu/hr (LHV, 60% relative humidity, 100% load, 59°F compressor inlet and 14.7 psia). This ~~maximum~~ design heat input rate will vary depending upon turbine inlet conditions and the combustion turbine characteristics. Manufacturer's curves corrected for site conditions or equations for correction to other compressor inlet conditions shall be provided to the Department of Environmental Protection (DEP) within 45 days of completing the initial compliance testing [Design, Rule 62-210.200, F.A.C. (Definitions – Potential Emissions)].

The Department made these changes as indicated but using the heat inputs based on the manufacturer specifications listed in the permit application.

Specific Condition 10 Gas Heaters (GHs):

FPL requests the following changes: The ~~maximum~~ design heat input rate, based on the lower heating value (LHV) of the fuel to the ~~DFGHs~~ at ambient conditions of 59°F, 60% relative humidity, 100% load, and 14.7 psia ~~shall not exceed~~ is 176 MMBtu per hour.

The Department concurs with FPL and will revise Specific Condition 10 to reflect that it applies to “Gas Heaters.”

Specific Condition 19, Natural Gas Firing

FPL suggests the following changes: “The permittee shall provide manufacturer's emissions performance versus load diagrams for the DLN systems prior to their installation. DLN systems shall each be tuned upon initial operation to optimize emissions reductions consistent with normal operation and maintenance practices, and shall be maintained to minimize NO_x emissions and CO emissions, consistent with normal operation and maintenance practices. “

The Department agrees with FPL suggestions and made the changes accordingly.

Specific Condition 19 ISO Correction:

FPL suggests a couple of clarifying changes: Why is the Department requiring adherence to the 9 ppm NO_x limitation at ISO conditions during the initial performance testing? If this testing is meant to demonstrate compliance to the NSPS Subpart GG limitations, it should state those limits. On the other hand, if demonstration of the 9 ppm limitation is the objective, then ISO correction is inappropriate. Since adherence to the 9 ppm limit would, in effect, demonstrate compliance with the NSPS limitation, FPL suggests that the ISO correction be dropped.

Under the provisions of 40 CFR60.335 (c), NO_x results from initial performance tests must be converted to ISO standard day conditions. However, such correction is not required to demonstrate compliance with non-NSPS permit standard(s) as stated in Specific Condition 4.

Specific Condition 19.

FPL requests the following changes:

- Natural Gas Firing – ~~The concentration of~~ NO_x concentrations in the exhaust gas of each CT shall not exceed 9ppmvd at 15%O₂ on a 30-day rolling average basis when firing natural gas as measured by the CEMS (maintained in accordance with 40 CFR 75). Based on CEMS data at the end of each operating day, a new 30-day average rate is calculated from the arithmetic average of all valid hourly emission rates during the previous 30 operating days. Valid hourly emission rates shall not include periods of startup, shutdown or malfunction. In addition, NO_x emissions calculated as NO₂ ~~(at ISO conditions)~~ shall exceed neither 9ppmvd at 15% O₂ nor 65 lb. / hr to be demonstrated by initial performance test. Demonstration of compliance to the 9 ppmvd limitation shall be considered to be demonstration of compliance with the NSPS limitation.
- Distillate Oil Firing - ~~The concentration of~~ NO_x concentrations in the exhaust gas of each CT shall not exceed 42 ppmvd at 15%O₂ on a 24-hour block average basis when firing distillate oil as measured by the CEMS (maintained in accordance with 40 CFR 75). Based on CEMS data at the end of each operating day, a new 24-hour average rate is calculated from the arithmetic average of all valid hourly emission rates during the previous day. Valid hourly emission rates shall not include periods of startup, shutdown or malfunction. In addition, NO_x emissions calculated as NO₂ ~~(at ISO conditions)~~ shall exceed neither 42 ppmvd at 15% O₂ nor 355 lb. / hr to be demonstrated by initial distillate oil-firing performance test. Demonstration of compliance to the 42 ppmvd limitation shall be considered to be demonstration of compliance with the NSPS limitation.

The Department agrees with FPL suggestions and made the changes accordingly.

Specific Condition 30:

FPL suggests the following changes: "Notwithstanding the requirements of Rule 62-297.340, F.A.C., the use of pipeline natural gas is the method for determining compliance for SO₂ and PM₁₀ when firing natural gas. The use of very low sulfur (0.05% or less) oil is the method of compliance for SO₂ and PM₁₀ when firing distillate oil."

The Department agrees with FPL suggestions and made the changes accordingly.

Specific Condition 39. Continuous Monitoring System:

FPL states that Specific Conditions 39 and 40 appear to have elements of both excess emissions reporting as well as CEM requirements in each condition. In addition, the requirements of both 40 CFR 60 and 40 CFR 75 do not always agree. FPL suggests the following change:

- 39 Continuous Monitoring System: The permittee shall install, calibrate, maintain and operate a continuous emission monitor in the stack to measure and record the nitrogen oxides emissions from each CT in accordance with the requirements of 40 CFR 75. ~~Thirty day rolling average periods when NO_x emissions (ppmvd at 15% oxygen) are above the standards, listed in Specific Conditions No 18 and 19, shall be provided to the DEP Bureau of Air Monitoring and Mobile Sources pursuant to 40 CFR 75 and a copy to the DEP Central District Office within one working day (verbally) followed up by a written explanation not later than three (3) working days (alternately by facsimile within one working day). [Rule 62-210.700 F.A.C., Rule 62-4.130, F.A.C., and 40 CFR 75].~~

The Department concurs with FPL and this condition is revised as requested. FPL shall comply with all the applicable requirements of 40 CFR 75. This condition is related to specific condition No. 40 below.

Specific Condition 40.

40 CEMS for reporting excess emissions.; The NOx CEMS may be used in lieu of the requirement for reporting excess emissions in 40 CFR 60.334©(1), Subpart GG (1998 version). Thirty day rolling average periods when NOx emissions (ppmvd at 15% oxygen) are above the standards, listed in Specific Conditions No 18 and 19, shall be provided to the DEP Central District Office within one working day (verbally) followed up by a written explanation not later than three (3) working days (alternately by facsimile). within one working day. Frequency data reports shall be submitted as specified in 40 CFR 60.7(c). CEM monitor downtime shall be calculated and reported according to the requirements of 40 CFR 75 in lieu of the requirements of 40 CFR 60.7(c)(3) and 40 CFR 60.7(d)(1) and 40 CFR 60.7(d)(2). Upon request from DEP, the CEMS emission rates for NOx on each CT shall be correct to ISO conditions to demonstrate compliance with the NOx standard established in 40 CFR 60.332. [Rule 62-204.800 F.A.C., and 40 CFR 60.7].

The Department agrees with FPL comment and revised this condition accordingly. CEM monitor downtime shall be calculated and reported according to the requirements of 40 CFR 60.7(c)(3) and 40 CFR 60.7(d)(1) and 40 CFR 60.7(d)(2) only. FPL shall comply with all the applicable requirements of 40 CFR 75 and 40CFR60.

Specific Condition No. 46 Facility-wide Emissions Caps:

FPL suggests the following language to make this specific condition enforceable, and to clarify when the facility-wide emissions caps take effect:

Facility-wide Emission Caps. The entire facility including repowered Units 4 and 5 and existing Unit 3, shall be limited to emission caps of 500 TPY of PM/PM₁₀, 4,500 TPY of NO_x, and 4,000 of SO₂. This limitation shall not become effective until 2003, following the initial startup testing and placing into commercial operation of repowered Units 4 and 5. [Applicant Request]

a. For the purpose of complying with the facility-wide emission cap, particulate matter emissions shall be calculated as follows:

Facility-wide Particulate Emissions (PM_{Total}) = Unit 3 PM emissions (PM₃) + Unit 4 PM emissions (PM₄) + Unit 5 PM emissions (PM₅) where:

PM₄ = annual heat input (mmBtu) x 0.0006 lb/mmBtu

PM₅ = PM_{5gas} + PM_{5oil}

PM_{5gas} = annual gas operation heat input (mmBtu) x 0.006 lb/mmBtu

PM_{5oil} = annual oil operation heat input (mmBtu) x 0.01 lb/mmBtu

PM₃ = PM_{3oil} + PM_{3gas}

PM_{3oil} = Annual oil heat input (mmBtu) x normalized annual stack test results (Fp), where

Fp = [(steady state PM test result x 16 hours) + (sootblowing PM test result x 8 hours)]/24 hrs

PM_{3gas} = Annual gas operation heat input x 0.0076 lb/mmBtu

b. For the purpose of complying with the facility-wide emission cap, sulfur dioxide emissions shall be calculated by annually summing the data collected in the continuous emissions monitoring system required by Title IV of the Clean Air Act.

The Department concurs with this rationale and this condition is revised as requested.

TECHNICAL EVALUATION AND PRELIMINARY DETERMINATION (TEPD):

FPL comments regarding the TEPD follows:

Page TE-4, second-to-last sentence in the first paragraph: "The HRSGs will ~~raise-steam~~ capture waste heat to repower the existing steam turbines thus producing approximately another 80 MW of electricity per unit or 2,200 for the eight combined cycle units."

In the second paragraph, second sentence: "Each turbine will have a nominal heat input of ~~1,600~~ 1,760 million BTUs per hour, lower heating value (MMBtu/hr, LHV) at 59°F. The HRSGs will not be supplementally fired and will ~~raise-steam~~ capture waste heat only from hot (~~1,100-1,130~~ 1,130°F) combustion turbine exhaust."

Page TE-16, second-to-last sentence in first paragraph: "The limit for oil ~~is~~ is consistent...."

The Department acknowledges these comments. Since there is not a revised or final TEPD document after the Intent To Issue the Permit is mailed out, FPL comments would be filed with all the documents for this project. Changes will be made in their permit where appropriate.

CONCLUSION

The final action of the Department is to issue the permit with the changes described above.



Jeb Bush
Governor

Department of Environmental Protection

Twin Towers Office Building
2600 Blair Stone Road
Tallahassee, Florida 32399-2400

David B. Struhs
Secretary

PERMITTEE:

Florida Power & Light Company
Sanford Power Plant
950 South Highway 17-92
DeBary, Florida 32713

Permit No.	1270009-004-AC (PSD-FL-270)
Project:	2200 MW Repowering Project
SIC No.	4911
Expires:	December 31, 2003

Authorized Representative:

Roxane Kennedy
Plant General Manager

PROJECT AND LOCATION:

Permit to install eight (8) combined cycle units to replace two (2) residual oil-fired and gas-fired steam boiler generating units. Each combined cycle unit is a 170 megawatt General Electric MS7241FA gas-fired combustion turbine-generator with an unfired heat recovery steam generator (HRSG) that will capture sufficient waste heat to produce another 80 MW via the existing steam-driven electrical generators. The boilers and the tall stacks associated with two existing residual oil-fired and gas-fired units (872 MW total capacity for Units 4 and 5) will be dismantled and replaced by relatively short stacks per unit for simple cycle (Repowered Unit 4 only) and combined cycle operation. The project also includes a helper cooling tower for once-through cooling pond water and small heaters with individual 10-foot stack to heat the natural gas prior to use during simple cycle operation and cold start-ups.

This facility is located at 950 South Highway 17-92, DeBary, Volusia County. UTM coordinates are: Zone 17; 468.3 km E and 3,190.3 km N.

STATEMENT OF BASIS:

This construction permit is issued under the provisions of Chapter 403 of the Florida Statutes (F.S.), and Chapters 62-4, 62-204, 62-210, 62-212, 62-296, and 62-297 of the Florida Administrative Code (F.A.C.). The above named permittee is authorized to modify the facility in accordance with the conditions of this permit and as described in the application, approved drawings, plans, and other documents on file with the Department of Environmental Protection (Department).

ATTACHED APPENDIX MADE A PART OF THIS PERMIT:

Appendix GC

Construction Permit General Conditions

Howard L. Rhodes, Director
Division of Air Resources
Management

"Protect, Conserve and Manage Florida's Environment and Natural Resources"

AIR CONSTRUCTION PERMIT 1270009-004-AC and PSD-FL-270

SECTION I. FACILITY INFORMATION

FACILITY DESCRIPTION

Currently, this facility generates electric power from three residual fuel oil-fired and gas-fired steam units with a combined generating capacity of 1,028 megawatts (MW).

This permitting action (approximately 2,200 MW Repowering Project) is to install eight (8) combined cycle units to replace two (2) residual oil-fired and gas-fired steam generating boiler units; existing steam turbines will remain. Each combined cycle unit is a 170 megawatt General Electric MS7241FA gas-fired combustion turbine-generator with an unfired heat recovery steam generator (HRSG) that will capture sufficient waste heat to produce another 80 MW via the existing steam-driven electrical generators. The boilers and the tall stacks associated with two existing residual oil-fired and gas-fired units (872 MW total capacity) will be dismantled and replaced by relatively short stacks per unit for simple cycle and combined cycle operation. The project also includes a helper cooling tower for once-through cooling pond water and small heaters with individual 10-foot stacks to heat the natural gas prior to use during simple cycle operation and cold start-ups.

This Project is exempt from the requirements of Rule 62-212.400, F.A.C., Prevention of Significant Deterioration (PSD) as stated in the Technical Evaluation and Preliminary Determination dated July 30, 1999, for all pollutants except Volatile Organic Compounds (VOCs).

EMISSION UNITS

This permit addresses the following emission units:

EMISSION UNIT NO.	SYSTEM	EMISSION UNIT DESCRIPTION
004-011	Power Generation	Eight (8) Combined Cycle Combustion Turbine-Generators with Unfired Heat Recovery Steam Generators
012-019	Fuel Heating	Natural Gas Heater(s)
020	Water Cooling	Mechanical Draft Cooling Tower

REGULATORY CLASSIFICATION

This facility, FPL Sanford Power Plant, is classified as a Major or Title V Source of air pollution because emissions of at least one regulated air pollutant, such as particulate matter (PM/PM₁₀), sulfur dioxide (SO₂), nitrogen oxides (NO_x), carbon monoxide (CO), or volatile organic compounds (VOC) exceeds 100 tons per year (TPY).

This facility is within an industry included in the list of the 28 Major Facility Categories per Table 62-212.400-1, F.A.C. Because emissions are greater than 100 TPY for at least one criteria pollutant, the facility is also a Major Facility with respect to Rule 62-212.400, Prevention of Significant Deterioration (PSD).

AIR CONSTRUCTION PERMIT 1270009-004-AC and PSD-FL-270

SECTION I. FACILITY INFORMATION

This facility is a major source of hazardous air pollutants (HAPs) and is also subject to the provisions of Title IV, Acid Rain, Clean Air Act as amended in 1990.

PERMIT SCHEDULE

- 8/5/99 Notice of Intent published in the News Journal
- 7/30/99 Distributed Intent to Issue Permit
- 6/15/99 Received Application

RELEVANT DOCUMENTS:

The documents listed below are the basis of the permit. They are specifically related to this permitting action, but not all are incorporated into this permit. These documents are on file with the Department.

- Application received on June 15, 1999
- U.S. Fish and Wildlife Service comments dated June 22, 1999
- Department's Intent to Issue and Public Notice Package dated July 30, 1999.
- FPL's comments dated August 17, 1999.

AIR CONSTRUCTION PERMIT 1270009-004-AC and PSD-FL-270

SECTION II. EMISSION UNIT(S) GENERAL REQUIREMENTS

GENERAL AND ADMINISTRATIVE REQUIREMENTS

1. Regulating Agencies: All documents related to applications for permits to construct, operate or modify an emissions unit should be submitted to the Bureau of Air Regulation (BAR), Florida Department of Environmental Protection (DEP), at 2600 Blairstone Road, Tallahassee, Florida 32399-2400 and phone number (850)488-0114. All documents related to reports, tests, and notifications should be submitted to the DEP Central District office, 3319 Maguire Boulevard, Suite 232, Orlando, Florida 32703-3767 and phone number (407) 894-7555.
2. General Conditions: The owner and operator is subject to and shall operate under the attached General Permit Conditions G.1 through G.15 listed in Appendix GC of this permit. General Permit Conditions are binding and enforceable pursuant to Chapter 403 of the Florida Statutes. [Rule 62-4.160, F.A.C.]
3. Terminology: The terms used in this permit have specific meanings as defined in the corresponding chapters of the Florida Administrative Code.
4. Forms and Application Procedures: The permittee shall use the applicable forms listed in Rule 62-210.900, F.A.C. and follow the application procedures in Chapter 62-4, F.A.C. [Rule 62-210.900, F.A.C.]
5. Modifications: The permittee shall give written notification to the Department when there is any modification to this facility. This notice shall be submitted sufficiently in advance of any critical date involved to allow sufficient time for review, discussion, and revision of plans, if necessary. Such notice shall include, but not be limited to, information describing the precise nature of the change; modifications to any emission control system; production capacity of the facility before and after the change; and the anticipated completion date of the change. [Chapters 62-210 and 62-212]
6. Permit Extension: *This permit expires on December 31, 2003.* The permittee, for good cause, may request that this construction permit be extended. Such a request shall be submitted to the Bureau of Air Regulation prior to 60 days before the expiration of the permit. [Rule 62-4.080, F.A.C.].
7. Application for Title V Permit: An application for a Title V operating permit, pursuant to Chapter 62-213, F.A.C., must be submitted to the DEP's Bureau of Air Regulation, and a copy sent to the Department's Central District office. [Chapter 62-213, F.A.C.] The application shall reflect the plant-wide emission caps requested in this proposed repowering project. [Applicant's Request]
8. New or Additional Conditions: Pursuant to Rule 62-4.080, F.A.C., for good cause shown and after notice and an administrative hearing, if requested, the Department may require the permittee to conform to new or additional conditions. The Department shall allow the permittee a reasonable time to conform to the new or additional conditions, and on application of the permittee, the Department may grant additional time. [Rule 62-4.080, F.A.C.]

AIR CONSTRUCTION PERMIT 1270009-004-AC and PSD-FL-270

SECTION II. EMISSION UNIT(S) GENERAL REQUIREMENTS

9. Annual Reports: Pursuant to Rule 62-210.370(2), F.A.C., Annual Operation Reports, the permittee is required to submit annual reports on the actual operating rates and emissions from this facility. Annual operating reports shall be sent to the DEP's Central District office by March 1st of each year.
10. Stack Testing Facilities: Stack sampling facilities shall be installed in accordance with Rule 62-297.310(6), F.A.C.
11. Quarterly Reports: Quarterly excess emission reports, in accordance with 40 CFR 60.7 (a)(7) (c) (1998 version), shall be submitted to the DEP's Central District office.

AIR CONSTRUCTION PERMIT 1270009-004-AC and PSD-FL-270

SECTION III. EMISSION UNIT(S) SPECIFIC CONDITIONS

APPLICABLE STANDARDS AND REGULATIONS:

1. Unless otherwise indicated in this permit, the construction and operation of the subject emission unit(s) shall be in accordance with the capacities and specifications stated in the application. The facility is subject to all applicable provisions of Chapter 403, F.S. and Florida Administrative Code Chapters 62-4, 62-103, 62-204, 62-210, 62-212, 62-213, 62-214, 62-296, and 62-297; and the applicable requirements of the Code of Federal Regulations Section 40, Parts 60, 72, 73, and 75.
2. Issuance of this permit does not relieve the facility owner or operator from compliance with any applicable federal, state, or local permitting requirements or regulations. [Rule 62-210.300, F.A.C.]
3. These emission units shall comply with all applicable requirements of 40 CFR 60, Subpart A, General Provisions including:
 - 40 CFR 60.7, Notification and Recordkeeping
 - 40 CFR 60.8, Performance Tests
 - 40 CFR 60.11, Compliance with Standards and Maintenance Requirements
 - 40 CFR 60.12, Circumvention
 - 40 CFR 60.13, Monitoring Requirements
 - 40 CFR 60.19, General Notification and Reporting requirements
4. ARMS Emission Units 004 through 011, Power Generation, consisting of eight (nominal) 170 MW combustion turbines (250 MW in combined cycle operation), shall comply with all applicable provisions of 40CFR60, Subpart GG, Standards of Performance for Stationary Gas Turbines, adopted by reference in Rule 62-204.800(7)(b), F.A.C. The Subpart GG requirement to correct test data to ISO conditions applies. However, such correction is not required to demonstrate compliance with non-NSPS permit standard(s).
5. ARMS Emission Unit 012-019, Fuel Heating, shall comply with all applicable provisions in this permit.
6. ARMS Emission Unit 020, Cooling Tower, is an unregulated emission unit.
7. All notifications and reports required by the above specific conditions shall be submitted to the DEP's Central District-office.

GENERAL OPERATION REQUIREMENTS

8. Fuels: Pipeline natural gas shall be the primary fuel fired in these units. When gas is not available, up to 28,600,000 gallons per year of distillate oil (0.05% sulfur) is authorized for repowered Unit 5; (ARMS emission units 008-011). [Applicant Request, Rule 62-210.200, F.A.C. (Definitions - Potential Emissions)]

008 ↓
012 ↓

020

AIR CONSTRUCTION PERMIT 1270009-004-AC and PSD-FL-270

SECTION III. EMISSION UNIT(S) SPECIFIC CONDITIONS

9. Turbine Capacity: The design heat input rates for natural gas firing, based on the high heating value (HHV) of the fuel to *each* combustion turbine at compressor inlet conditions of 59°F, 60% relative humidity, 100% load, and 14.7 psia is 1,776 million Btu per hour (MMBtu/hr). The design heat input for oil firing is 1,930 MMBtu/hr (HHV, 60% relative humidity, 100% load, 59°F compressor inlet and 14.7 psia). This design heat input rate will vary depending upon turbine inlet conditions and the combustion turbine characteristics. Manufacturer's curves corrected for site conditions or equations for correction to other compressor inlet conditions shall be provided to the Department of Environmental Protection (DEP) within 45 days of completing the initial compliance testing. [Design, Rule 62-210.200, F.A.C. (Definitions - Potential Emissions)]
10. Gas Heaters (GHs). The design heat input rate, based on the lower heating value (LHV) of the fuel to the GHs at ambient conditions of 59°F, 60% relative humidity, 100% load, and 14.7 psia is 176 MMBtu per hour.
11. Unconfined Particulate Emissions: During the construction period, unconfined particulate matter emissions shall be minimized by dust suppressing techniques such as covering and/or application of water or chemicals to the affected areas, as necessary.
12. Plant Operation - Problems: If temporarily unable to comply with any of the conditions of the permit due to breakdown of equipment or destruction by fire, wind or other cause; the owner or operator shall notify the DEP Central District office as soon as possible, but at least within (1) working day, excluding weekends and holidays. The notification shall include: pertinent information as to the cause of the problem; the steps being taken to correct the problem and prevent future recurrence; and where applicable, the owner's intent toward reconstruction of destroyed facilities. Such notification does not release the permittee from any liability for failure to comply with the conditions of this permit and the regulations. [Rule 62-4.130, F.A.C.]
13. Operating Procedures: Operating procedures shall include good operating practices and proper training of all operators and supervisors. The good operating practices shall meet the guidelines and procedures as established by the equipment manufacturers. All operators (including supervisors) of air pollution control devices shall be properly trained in plant specific equipment. [Rule 62-4.070(3), F.A.C.]
14. Circumvention: The owner or operator shall not circumvent the air pollution control equipment or allow the emission of air pollutants without this equipment operating properly. [Rule 62-210.650, F.A.C.]
15. Maximum Annual Allowable Hours of operation for each of the eight combustion turbines, the cooling tower, and the gas heaters (ARMS Emission Units 004-020) are 8,760. [Applicant Request, Rule 62-210.200, F.A.C. (Definitions - Potential Emissions)]

AIR CONSTRUCTION PERMIT 1270009-004-AC and PSD-FL-270

SECTION III. EMISSION UNIT(S) SPECIFIC CONDITIONS

CONTROL TECHNOLOGY

16. Dry Low NO_x (DLN) combustor shall be installed on each stationary combustion turbine to control nitrogen oxides (NO_x) emissions. Water injection shall be installed in the turbine for Repowered Unit 5 to control NO_x when firing distillate oil. [Design, Rule 62-4.070, F.A.C.]
17. The permittee shall provide manufacturer's emissions performance versus load diagrams for the DLN systems prior to their installation. DLN systems shall each be tuned upon initial operation to optimize emissions reductions consistent with normal operation and maintenance practices, and shall be maintained to minimize NO_x emissions and CO emissions, consistent with normal operation and maintenance practices. [Rule 62-4.070, and 62-210.650 F.A.C.]

EMISSION LIMITS AND STANDARDS

18. Following are the emission limits determined for this project assuming full load. Values for NO_x are corrected to 15% O₂ on a dry basis. These limits or their equivalents in terms of pounds per hour, as well as the applicable averaging times, are followed by the applicable specific conditions. [Applicant Requests, Rules 62-204.800(7)(b) (Subparts GG), 62-210.200 (Definitions-Potential Emissions), F.A.C.].

Emission Unit	NO _x	CO	VOC	PM/Visibility (% Opacity)	Technology and Comments
Combustion Turbines (each)	9 ppm (30 day) - gas 42 ppm - oil 75/110 ppm (NSPS)	12 ppmvd - gas 20 ppmvd - oil	1.4 ppmvd 7 ppmvw	10 - gas 20 - oil	Dry Low NO _x Combustors Natural Gas or 0.05% S Fuel Oil Good Combustion Water Injection on Fuel Oil
Gas Heaters	0.10 lb/mmBtu	0.15 lb/mmBtu		10	Low NO _x Burners

19. Nitrogen Oxides Emissions Limits:

- Natural Gas Firing: The NO_x concentrations in the exhaust gas of each CT shall not exceed 9 ppmvd at 15% O₂ on a 30-day rolling average basis when firing natural gas as measured by the CEMS (maintained in accordance with 40 CFR 75). Based on CEMS data at the end of each operating day, a new 30-day average rate is calculated from the arithmetic average of all valid hourly emission rates during the previous 30 operating days. Valid hourly emission rates shall not include periods of startup, shutdown or malfunction. In addition, NO_x emissions calculated as NO₂ shall exceed neither 9 ppmvd at 15% O₂ nor 65 lb/hr (at ISO conditions) to be demonstrated by initial performance test.
- Distillate Oil Firing - The NO_x concentrations in the exhaust gas of each CT shall not exceed 42 ppmvd at 15% O₂ on a 24-hour block average basis when firing distillate oil as measured by the CEMS (maintained in accordance with 40 CFR 75). Based on CEMS data at the end of each operating day, a new 24-hour average rate is calculated from the arithmetic average of all

AIR CONSTRUCTION PERMIT 1270009-004-AC and PSD-FL-270

SECTION III. EMISSION UNIT(S) SPECIFIC CONDITIONS

valid hourly emission rates during the previous day. Valid hourly emission rates shall not include periods of startup, shutdown or malfunction. In addition, NO_x emissions calculated as NO₂ shall exceed neither 42 ppm at 15% O₂ nor 355 lb/hr (at ISO conditions) to be demonstrated by initial distillate oil-firing performance test.

- When NO_x monitoring data is not available, substitution for missing data shall be handled as required by Title IV (40 CFR 75) to calculate the 30 day rolling average or 24-hour block average emission rates.
 - NO_x emission limit from the gas heaters shall not exceed 0.10 lb/mmBtu (at ISO conditions) to be demonstrated by representative stack test on one unit. The permittee may construct one heater within the heat input limit specified in Specific Condition 10. If the unit is classified as a "steam generating unit" in 40 CFR 60.41b, than the requirements of 40 CFR Subpart Db apply.
20. Visible Emissions (VE): VE emissions from the combustion turbines shall not exceed 10 percent opacity during gas firing and 20 percent opacity during oil firing. Visible emissions from the gas heaters shall not exceed 10 percent opacity.
21. Carbon Monoxide (CO) emissions: The concentration of CO (@15% O₂ in the exhaust gas shall not exceed 12 ppmvd when firing natural gas and 20 ppmvd when firing distillate oil as measured by EPA Method 10 at full-load conditions. CO emissions (at ISO conditions) shall not exceed 43 lb/hr (per CT) when firing natural gas and 71.6 lb/hr (per CT) when firing distillate oil to be demonstrated by stack test.
22. Volatile Organic Compounds (VOC) Emissions: The concentration of VOC in the exhaust gas shall not exceed 1.4 ppmvd when firing natural gas and 7 ppmvw when firing distillate oil as determined by EPA Methods 18 or 25 A. VOC emissions (at ISO conditions) shall not exceed 2.9 lb/hr per CT when firing natural gas and 16.1 lb/hr when firing distillate oil to be demonstrated by initial stack test.
23. Sulfur Dioxide (SO₂) emissions: As per Condition 8.

EXCESS EMISSIONS

24. Excess Emissions Requirements:
- Excess emissions resulting from startup, shutdown, or malfunction of the *combustion turbines and heat recovery steam generators* shall be permitted provided that best operational practices are adhered to and the duration of excess emissions shall be minimized. Excess emissions occurrences shall in no case exceed two hours in any 24-hour period except during both "cold start-up" to or shutdowns from combined cycle operation. During cold start-up to combined cycle operation, up to four hours of excess emissions are allowed. During shutdowns from combined cycle operation, up to three hours of excess emissions are allowed. Cold start-up is defined as a startup to combined cycle operation following a complete shutdown lasting at least 48 hours.

AIR CONSTRUCTION PERMIT 1270009-004-AC and PSD-FL-270

SECTION III. EMISSION UNIT(S) SPECIFIC CONDITIONS

- Excess emissions from the combustion turbines resulting from startup of the *steam turbines system* shall be permitted provided that best operational practices are adhered to and the duration of excess emissions shall be minimized. Excess emissions occurrences shall in no case exceed 12 hours per cold startup of the steam turbine system.

[Applicant Request (FPL estimates that, on average, there will be approximately 12 startups to combined-cycle operation per year), G.E. Combined Cycle Startup Curves Data and Rules 62-210.700, 62-4.130 F.A.C.].

25. Excess emissions entirely or in part by poor maintenance, poor operation, or any other equipment or process failure that may reasonably be prevented during startup, shutdown or malfunction, shall be prohibited pursuant to Rule 62-210.700, F.A.C.
26. Excess Emissions Report: If excess emissions occur for more than two hours due to malfunction, the owner or operator shall notify DEP's Central District office within (1) working day of: the nature, extent, and duration of the excess emissions; the cause of the excess emissions; and the actions taken to correct the problem. In addition, the Department may request a written summary report of the incident. Pursuant to the New Source Performance Standards, all excess emissions shall also be reported in accordance with 40 CFR 60.7, Subpart A. Following this format, 40 CFR 60.7, periods of startup, shutdown, malfunction, and fuel switching shall be monitored, recorded, and reported as excess emissions when emission levels exceed the permitted standards listed in Specific Condition No. 18 and 19. [Rules 62-4.130, 62-204.800, 62-210.700(6), F.A.C., and 40 CFR 60.7 (1998 version)].

COMPLIANCE DETERMINATION

27. Compliance with the allowable emission limiting standards shall be determined within 60 days after achieving the maximum production rate at which each unit will be operated, but not later than 180 days following initial operation of the unit, and annually thereafter as indicated in this permit, by using the following reference methods as described in 40 CFR 60, Appendix A (1998 version), and adopted by reference in Chapter 62-204.800, F.A.C.
28. Initial (I) performance tests shall be performed pursuant to 40 CFR Subpart GG. Annual (A) compliance tests shall be performed during every federal fiscal year (October 1 - September 30) pursuant to Rule 62-297.310(7), F.A.C., on each CT as indicated. The following reference methods shall be used. No other test methods may be used for compliance testing unless prior DEP approval is received in writing.
- EPA Reference Method 9, "Visual Determination of the Opacity of Emissions from Stationary Sources" (I, A).
 - EPA Reference Method 10, "Determination of Carbon Monoxide Emissions from Stationary Sources" (I, A).

AIR CONSTRUCTION PERMIT 1270009-004-AC and PSD-FL-270

SECTION III. EMISSION UNIT(S) SPECIFIC CONDITIONS

- EPA Reference Method 20, "Determination of Oxides of Nitrogen Oxide, Sulfur Dioxide and Diluent Emissions from Stationary Gas Turbines." Initial test only for compliance with 40CFR60 Subpart GG.
- EPA Reference Method 18, and/or 25A, "Determination of Volatile Organic Concentrations." Initial test only.
- EPA Reference Method 19. "Determination of Sulfur Dioxide Removal Efficiency and Particulate Matter, Sulfur Dioxide, and Nitrogen Oxides Emission Rates". Method 19 shall be used only for the calculation of lb/mmBtu and 40 CFR 75 shall be used to calculate mmBtu/hr and lb/hr emissions rates from stack tests. Initial test only.

29. Continuous compliance with the NO_x emission limits:

- Continuous compliance with the NO_x emission limits when firing natural gas shall be demonstrated with the CEM system based on a 30-day rolling average. Based on CEMS data, a separate compliance determination is conducted at the end of each operating day and a new 30 day average emission rate is calculated from the arithmetic average of all valid hourly emission rates during the previous 30 operating days. Valid hourly emission rates shall not include periods of startup, shutdown, or malfunction. [Rules 62-4.070 F.A.C., 62-210.700, F.A.C., and 40 CFR 75]
- Compliance with the NO_x emission limits when firing oil shall be demonstrated with the CEM system based on a 24-hour block average. Based on CEMS data, a separate compliance determination is conducted at the end of each operating day and is calculated from the arithmetic average of all valid hourly emission rates during the previous day. Valid hourly emission rates shall not include periods of startup, shutdown, or malfunction. A valid hourly emission rate shall be calculated for each hour in which at least two NO_x concentrations are obtained at least 15 minutes apart. [Rules 62-4.070 F.A.C., 62-210.700, F.A.C., and 40 CFR 75]

30. Compliance with the SO₂ and PM/PM₁₀ emission limits: Notwithstanding the requirements of Rule 62-297.340, F.A.C., the use of pipeline natural gas is the method for determining compliance for SO₂ and PM₁₀ when firing natural gas. The use of very low sulfur (0.05% or less) is the method of compliance for SO₂ and PM₁₀ when firing distillate oil.

For the purposes of demonstrating compliance with the 40 CFR 60.333, when firing natural gas, data from the pipeline natural gas supplier may be submitted or the natural gas sulfur content referenced in 40 CFR 75 Appendix D may be utilized. Gas analysis, if conducted, may be performed by the owner or operator, a service contractor retained by the owner or operator, the fuel vendor, or any other qualified agency pursuant to 40 CFR 60.335(e) (1998 version). However, the applicant is responsible for ensuring that the procedures in 40 CFR 60.333 or 40 CFR 75 are used for determination of fuel sulfur content if gas analysis is done.

Compliance when firing distillate oil, shall follow the requirements of 40 CFR 60.33.4(a)(1) using methods specified in ASTM 2880-96 (or latest version).

AIR CONSTRUCTION PERMIT 1270009-004-AC and PSD-FL-270

SECTION III. EMISSION UNIT(S) SPECIFIC CONDITIONS

31. Compliance with CO emission limit: An initial test for CO, shall be conducted concurrently with the initial NO_x test while operating at permitted capacity. These initial NO_x and CO test results shall be the average of three runs. Annual compliance testing for CO may be conducted at less than capacity when compliance testing is conducted concurrent with the annual NO_x RATA testing which is performed pursuant to 40 CFR 75.
32. Compliance with the VOC emission limit: An initial test is required to demonstrate compliance with the VOC emission limit. Thereafter, CO emission limit will be employed as a surrogate and no annual testing is required.
33. Testing procedures: Testing of emissions shall be conducted with the combustion turbine operating at permitted capacity. Permitted capacity is defined as 95-100 percent of the maximum heat input rate allowed by the permit, corrected for the average compressor inlet temperature during the test (with 100 percent represented by a curve depicting heat input vs. compressor inlet temperature). If it is impracticable to test at permitted capacity, the source may be tested at less than permitted capacity. In this case, subsequent operation is limited by adjusting the entire heat input vs. compressor inlet temperature curve downward by an increment equal to the difference between the maximum permitted heat input (corrected for compressor inlet temperature) and 105 percent of the value reached during the test until a new test is conducted. Once the unit is so limited, operation at higher capacities is allowed for no more than 15 consecutive days for the purposes of additional compliance testing to regain the permitted capacity. Test procedures shall meet all applicable requirements (i.e., testing time frequency, minimum compliance duration, etc.) of Chapter 62-204 and 62-297 F.A.C.
34. Test Notification: The DEP's Central District office shall be notified, in writing, at least 30 days prior to the initial performance tests and at least 15 days before annual compliance test(s).
35. Special Compliance Tests: The DEP may request a special compliance test pursuant to Rule 62-297.310(7), F.A.C., when, after investigation (such as complaints, increased visible emissions, or questionable maintenance of control equipment), there is reason to believe that any applicable emission standard is being violated.
36. Test Results: Compliance test results shall be submitted to the DEP's Central District office no later than 45 days after completion of the last test run.

NOTIFICATION, REPORTING, AND RECORDKEEPING

37. Records: All measurements, records, and other data required to be maintained by the permittee shall be recorded in a permanent form and retained for at least five (5) years following the date on which such measurements, records, or data are recorded. These records shall be made available to DEP representatives upon request.
38. Emission Compliance Stack Test Reports: A test report indicating the results of the required compliance tests shall be filed with the DEP Central District Office as soon as practical, but no later than 45 days after the last sampling run is completed. [Rule 62-297.310(8), F.A.C.]. The test report shall provide sufficient detail on the tested emission unit and the procedures used to

AIR CONSTRUCTION PERMIT 1270009-004-AC and PSD-FL-270

SECTION III. EMISSION UNIT(S) SPECIFIC CONDITIONS

allow the Department to determine if the test was properly conducted and if the test results were properly computed. At a minimum, the test report shall provide the applicable information listed in Rule 62-297.310(8), F.A.C.

MONITORING REQUIREMENTS

39. Continuous Monitoring System: The permittee shall install, calibrate, maintain, and operate a continuous emission monitor in the stack to measure and record the nitrogen oxides emissions from each CT in accordance with the requirements of 40 CFR 75.
40. CEMS for reporting excess emissions: The NO_x CEMS may be used in lieu of the requirement for reporting excess emissions in 40 CFR 60.334(c)(1), Subpart GG (1998 version). Thirty day rolling average periods when NO_x emissions (ppmvd at 15% oxygen) are above the standards, listed in Specific Conditions No. 18 and 19, shall be provided to the DEP Central District Office within one working day (verbally) followed up by a written explanation not later than three (3) working days (alternately by facsimile). Excess Emissions and Monitoring System Performance Reports shall be submitted as specified in 40 CFR 60.7(c). CEM monitor downtime shall be calculated and reported according to the requirements of 40 CFR 60.7(c)(3) and 40 CFR 60.7(d)(2). Upon request from DEP, the CEMS emission rates for NO_x on each CT shall be corrected to ISO conditions to demonstrate compliance with the NO_x standard established in 40 CFR 60.332. [Rule 62-204.800 F.A.C., 40CFR75 and 40 CFR 60.7]
41. CEMS in lieu of Water to Fuel Ratio: The NO_x CEMS shall be used in lieu of the water/fuel monitoring system for reporting excess emissions in accordance with 40 CFR 60.334(c)(1), Subpart GG (1998 version). The calibration of the water/fuel monitoring device required in 40 CFR 60.335(c) (2) (1998 version) will be replaced by the 40 CFR 75 certification tests of the NO_x CEMS. Upon request from DEP, the CEMS emission rates for NO_x on this Unit shall be corrected to ISO conditions to demonstrate compliance with the NO_x standard established in 40 CFR 60.332.
42. Continuous Monitoring System Reports: The monitoring devices shall comply with the certification and quality assurance, and any other applicable requirements of Rule 62-297.520, F.A.C., 40 CFR 60.13, including certification of each device in accordance with 40 CFR 60, Appendix B, Performance Specifications and 40 CFR 60.7(a)(5) or 40 CFR Part 75. Quality assurance procedures must conform to all applicable sections of 40 CFR 60, Appendix F or 40 CFR 75. The monitoring plan, consisting of data on CEM equipment specifications, manufacturer, type, calibration and maintenance needs, and its proposed location shall be provided to the DEP Emissions Monitoring Section Administrator and EPA for review no later than 45 days prior to the first scheduled certification test pursuant to 40 CFR 75.62 .
43. Natural Gas Monitoring Schedule: The following custom monitoring schedule for natural gas is approved in lieu of the daily sampling requirements of 40 CFR 60.334 (b)(2):
 - The permittee shall apply for an Acid Rain permit within the deadlines specified in 40 CFR 72.30.

AIR CONSTRUCTION PERMIT 1270009-004-AC and PSD-FL-270

SECTION III. EMISSION UNIT(S) SPECIFIC CONDITIONS

- The permittee shall submit a monitoring plan, certified by signature of the Designated Representative (DR), that commits to using a primary fuel of pipeline supplied natural gas (sulfur content less than 20 gr/100 scf pursuant to 40 CFR 75.11(d)(2)).
- Each unit shall be monitored for SO₂ emissions using methods consistent with the requirements of 40 CFR 75 and certified by the USEPA.

This custom fuel monitoring schedule will only be valid when pipeline natural gas is used as a primary fuel. If the primary fuel for these units is changed to a higher sulfur fuel, SO₂ emissions must be accounted for as required pursuant to 40 CFR 75.11(d).

44. Fuel Oil Monitoring Schedule: The following monitoring schedule for No. 2 or superior grade fuel oil shall be followed: For all bulk shipments of No. 2 or superior grade fuel oil received at the Sanford Station, an analysis which reports the sulfur content and nitrogen content of the fuel shall be provided by the fuel vendor. The analysis shall also specify the methods by which the analyses were conducted and shall comply with the requirements of 40 CFR 60.335(d).

45. Determination of Process Variables:

- The permittee shall operate and maintain equipment and/or instruments necessary to determine process variables, such as process weight input or heat input, when such data is needed in conjunction with emissions data to determine the compliance of the emissions unit with applicable emission limiting standards.
- Equipment and/or instruments used to directly or indirectly determine such process variables, including devices such as belt scales, weigh hoppers, flow meters, and tank scales, shall be calibrated and adjusted to indicate the true value of the parameter being measured with sufficient accuracy to allow the applicable process variable to be determined within 10% of its true value [Rule 62-297.310(5), F.A.C]

46. Facility-wide Emission Caps. The entire facility including repowered Units 4 and 5 and existing Unit 3, shall be limited to emission caps of 500 TPY of PM/PM₁₀, 4,500 TPY of NO_x, and 4,000 of SO₂. This limitation shall not become effective until 2003, following the initial startup testing and placing into commercial operation of repowered Units 4 and 5. [Applicant Request]

a. For the purpose of complying with the facility-wide emission cap, particulate matter emissions shall be calculated as follows:

Facility-wide Particulate Emissions (PM_{Total}) – Unit 3 PM emissions (PM₃) + Unit 4 PM emissions (PM₄) + Unit 5 PM emissions (PM₅) where

PM₄ = annual heat input (mmBtu) x 0.0006 lb/mmBtu

AIR CONSTRUCTION PERMIT 1270009-004-AC and PSD-FL-270

SECTION III. EMISSION UNIT(S) SPECIFIC CONDITIONS

$$PM_5 = PM_{5gas} + PM_{5oil}$$

$$PM_{5gas} = \text{annual gas operation heat input (mmBtu)} \times 0.006 \text{ lb/mmBtu}$$

$$PM_{5oil} = \text{annual oil operation heat input (mmBtu)} \times 0.01 \text{ lb/mmBtu}$$

$$PM_3 = PM_{3oil} + PM_{3gas}$$

$$PM_{3oil} = \text{Annual oil heat input (mmBtu)} \times \text{normalized annual stack test results (Fp), where}$$

$$Fp = [(\text{steady state PM test result} \times 16 \text{ hours}) + (\text{sootblowing PM test result} \times 8 \text{ hours})] / 24 \text{ hrs}$$

$$PM_{3gas} = \text{Annual gas operation heat input} \times 0.0076 \text{ lb/mmBtu}$$

- b. For the purpose of complying with the facility-wide emission cap, sulfur dioxide emissions shall be calculated by annually summing the data collected in the continuous emissions monitoring system required by Title IV of the Clean Air Act.
- c. For the purpose of complying with the facility-wide emission cap, nitrogen oxide emissions shall be calculated by annually summing the data collected in the continuous emissions monitoring system required by Title IV of the Clean Air Act.

BEST AVAILABLE CONTROL TECHNOLOGY DETERMINATION (BACT)

FPL Sanford Repowering Project PSD-FL-270 Volusia County, Florida

BACKGROUND

Florida Power & Light Company (FPL) proposes to install eight (8) natural gas-fired combined cycle units that will consist of eight (8) nominal 170 MW (@ 59°F) combustion turbine-generators with heat recovery steam generators (HRSGs). These will replace the existing boilers for Units 4 and 5 at the Sanford Power Plant in Volusia County. The HRSGs will capture waste heat to repower the existing steam turbines thus producing approximately another 80 MW of electricity per unit or 2,200 MW for the eight combined cycle units.

The project will result in a significant increase of volatile organic compounds (VOC) per Table 62-212.400-2, F.A.C. Therefore a determination of Best Available Control Technology is required for this pollutant.

DATE OF RECEIPT OF A BACT APPLICATION:

The application was received on June 15, 1998 and included a proposed BACT- VOC analysis prepared by the applicant's consultant, Golder Associates Inc.

REVIEW GROUP MEMBERS:

A. A. Linero, P.E., and Teresa Heron, Permit Engineer

BACT DETERMINATION REQUESTED BY THE APPLICANT:

The applicant has proposed good combustion practices to control VOC to 1.4 ppm while firing natural gas and 7 ppmvw when firing distillate oil.

According to the application, total annual emissions of VOC are expected to be approximately 119 TPY from the repowered units and 4.6 TPY for the direct fired heaters

BACT DETERMINATION PROCEDURE:

In accordance with Chapter 62-212, F.A.C., this BACT determination is based on the maximum degree of reduction of each pollutant emitted which the Department of Environmental Protection (Department), on a case by case basis, taking into account energy, environmental and economic impacts, and other costs, determines is achievable through application of production processes and available methods, systems, and techniques. In addition, the regulations state that, in making the BACT determination, the Department shall give consideration to:

- Any Environmental Protection Agency determination of BACT pursuant to Section 169, and any emission limitation contained in 40 CFR Part 60 - Standards of Performance for New Stationary Sources or 40 CFR Part 61 - National Emission Standards for Hazardous Air Pollutants.
- All scientific, engineering, and technical material and other information available to the Department.
- The emission limiting standards or BACT determination of any other state.
- The social and economic impact of the application of such technology.

BEST AVAILABLE CONTROL TECHNOLOGY DETERMINATION (BACT)

The EPA currently stresses that BACT should be determined using the "top-down" approach. The first step in this approach is to determine, for the emission unit in question, the most stringent control available for a similar or identical emission unit or emission unit category. If it is shown that this level of control is technically or economically unfeasible for the emission unit in question, then the next most stringent level of control is determined and similarly evaluated. This process continues until the BACT level under consideration cannot be eliminated by any substantial or unique technical, environmental, or economic objections.

BACT DETERMINATION BY THE DEPARTMENT

Volatile organic compound (VOC) emissions, like CO emissions, are formed due to incomplete combustion of fuel. The combustion turbine, particularly with the very high firing temperatures characteristic of the F-Class technology, is very efficient at destroying VOC.

The applicant has proposed good combustion practices to control VOC to 1.4 ppm while firing natural gas and 7 ppmvw when firing distillate oil. The limit for gas firing is equal to the lowest BACT-based VOC limit known to the Department. Further reduction by installation of oxidation catalyst was not determined to be cost-effective based on the applicant's estimate of \$63,400 per ton of VOC removed.

The limit for the limited oil firing case is consistent with levels established as BACT. According to GE, even lower VOC emissions were achieved during recent tests of the DLN-2.6 technology when firing natural gas.¹ Therefore, the Department accepts FPL VOC proposal as BACT for this repowering project.

DETAILS OF THE ANALYSIS MAY BE OBTAINED BY CONTACTING:

A. A. Linero, P.E. Administrator, New Source Review Section
Teresa Heron, Project Review Engineer, New Source Review Section
Department of Environmental Protection
Bureau of Air Regulation
2600 Blair Stone Road
Tallahassee, Florida 32399-2400

Recommended By:

Approved By:



C. H. Fancy, P.E., Chief
Bureau of Air Regulation



Howard L. Rhodes, Director
Division of Air Resources Management

9/14/99
Date:

9/14/99
Date:

References

¹ Telecon. Vandervort, C., GE, and Linero, A. A., DEP. VOC Emissions From FA Gas Turbines with DLN-2.6 Combustors.

APPENDIX GC
GENERAL PERMIT CONDITIONS [F.A.C. 62-4.160]

- G.1 The terms, conditions, requirements, limitations, and restrictions set forth in this permit are "Permit Conditions" and are binding and enforceable pursuant to Sections 403.161, 403.727, or 403.859 through 403.861, Florida Statutes. The permittee is placed on notice that the Department will review this permit periodically and may initiate enforcement action for any violation of these conditions.
- G.2 This permit is valid only for the specific processes and operations applied for and indicated in the approved drawings or exhibits. Any unauthorized deviation from the approved drawings or exhibits, specifications, or conditions of this permit may constitute grounds for revocation and enforcement action by the Department.
- G.3 As provided in Subsections 403.087(6) and 403.722(5), Florida Statutes, the issuance of this permit does not convey and vested rights or any exclusive privileges. Neither does it authorize any injury to public or private property or any invasion of personal rights, nor any infringement of federal, state or local laws or regulations. This permit is not a waiver or approval of any other Department permit that may be required for other aspects of the total project which are not addressed in the permit.
- G.4 This permit conveys no title to land or water, does not constitute State recognition or acknowledgment of title, and does not constitute authority for the use of submerged lands unless herein provided and the necessary title or leasehold interests have been obtained from the State. Only the Trustees of the Internal Improvement Trust Fund may express State opinion as to title.
- G.5 This permit does not relieve the permittee from liability for harm or injury to human health or welfare, animal, or plant life, or property caused by the construction or operation of this permitted source, or from penalties therefore; nor does it allow the permittee to cause pollution in contravention of Florida Statutes and Department rules, unless specifically authorized by an order from the Department.
- G.6 The permittee shall properly operate and maintain the facility and systems of treatment and control (and related appurtenances) that are installed or used by the permittee to achieve compliance with the conditions of this permit, as required by Department rules. This provision includes the operation of backup or auxiliary facilities or similar systems when necessary to achieve compliance with the conditions of the permit and when required by Department rules.
- G.7 The permittee, by accepting this permit, specifically agrees to allow authorized Department personnel, upon presentation of credentials or other documents as may be required by law and at a reasonable time, access to the premises, where the permitted activity is located or conducted to:
- a) Have access to and copy and records that must be kept under the conditions of the permit;
 - b) Inspect the facility, equipment, practices, or operations regulated or required under this permit, and,
 - c) Sample or monitor any substances or parameters at any location reasonably necessary to assure compliance with this permit or Department rules.
- Reasonable time may depend on the nature of the concern being investigated.
- G.8 If, for any reason, the permittee does not comply with or will be unable to comply with any condition or limitation specified in this permit, the permittee shall immediately provide the Department with the following information:
- a) A description of and cause of non-compliance; and
 - b) The period of noncompliance, including dates and times; or, if not corrected, the anticipated time the non-compliance is expected to continue, and steps being taken to reduce, eliminate, and prevent recurrence of the non-compliance.

APPENDIX GC
GENERAL PERMIT CONDITIONS [F.A.C. 62-4.160]

The permittee shall be responsible for any and all damages which may result and may be subject to enforcement action by the Department for penalties or for revocation of this permit.

- G.9 In accepting this permit, the permittee understands and agrees that all records, notes, monitoring data and other information relating to the construction or operation of this permitted source which are submitted to the Department may be used by the Department as evidence in any enforcement case involving the permitted source arising under the Florida Statutes or Department rules, except where such use is prescribed by Sections 403.73 and 403.111, Florida Statutes. Such evidence shall only be used to the extent it is consistent with the Florida Rules of Civil Procedure and appropriate evidentiary rules.
- G.10 The permittee agrees to comply with changes in Department rules and Florida Statutes after a reasonable time for compliance, provided, however, the permittee does not waive any other rights granted by Florida Statutes or Department rules.
- G.11 This permit is transferable only upon Department approval in accordance with Florida Administrative Code Rules 62-4.120 and 62-730.300, F.A.C., as applicable. The permittee shall be liable for any non-compliance of the permitted activity until the transfer is approved by the Department.
- G.12 This permit or a copy thereof shall be kept at the work site of the permitted activity.
- G.13 This permit also constitutes:
- a) Determination of Best Available Control Technology for VOC (X)
 - b) Determination of Prevention of Significant Deterioration for VOC (X); and
 - c) Compliance with New Source Performance Standards (X).
- G.14 The permittee shall comply with the following:
- a) Upon request, the permittee shall furnish all records and plans required under Department rules. During enforcement actions, the retention period for all records will be extended automatically unless otherwise stipulated by the Department.
 - b) The permittee shall hold at the facility or other location designated by this permit records of all monitoring information (including all calibration and maintenance records and all original strip chart recordings for continuous monitoring instrumentation) required by the permit, copies of all reports required by this permit, and records of all data used to complete the application or this permit. These materials shall be retained at least three years from the date of the sample, measurement, report, or application unless otherwise specified by Department rule.
 - c) Records of monitoring information shall include:
 - 1. The date, exact place, and time of sampling or measurements;
 - 2. The person responsible for performing the sampling or measurements;
 - 3. The dates analyses were performed;
 - 4. The person responsible for performing the analyses;
 - 5. The analytical techniques or methods used; and
 - 6. The results of such analyses.
- G.15 When requested by the Department, the permittee shall within a reasonable time furnish any information required by law which is needed to determine compliance with the permit. If the permittee becomes aware that relevant facts were not submitted or were incorrect in the permit application or in any report to the Department, such facts or information shall be corrected promptly.

ATTACHMENT PSNFS_14
COMPLIANCE REPORT AND PLAN

ATTACHMENT PSNFS_14
COMPLIANCE REPORT AND PLAN

The facility and emissions units identified in this application are in compliance with the Applicable Requirements identified in Sections II.B. and III.D. of the application form and attachments referenced in Section III.L. 12 (if included). Compliance is certified as of the date this application is submitted to the Florida Department of Environmental Regulation as required in Rule 62-213.420(1)(a) F.A.C.

ATTACHMENT PSNFS_15
COMPLIANCE CERTIFICATION



Department of Environmental Protection

Division of Air Resource Management

STATEMENT OF COMPLIANCE - TITLE V SOURCE

REASON FOR SUBMISSION (Check one to indicate why this statement of compliance is being submitted)

<input type="checkbox"/> Annual Requirement	<input type="checkbox"/> Transfer of Permit	<input type="checkbox"/> Permanent Facility Shutdown
REPORTING PERIOD*		REPORT DEADLINE**
<u>01/01</u> through <u>08/14</u> of <u>2002</u> (year)		<u>NA – due to permit modification</u>

*The statement of compliance must cover all conditions that were in effect during the indicated reporting period, including any conditions that were added, deleted, or changed through permit revision.

**See Rule 62-213.440(3)(a)2., F.A.C.

Facility Owner/Company Name: FPL Sanford Power Plant

Site Name: Sanford Plant Facility ID No. 1170009 County: Volusia

COMPLIANCE STATEMENT (Check only one of the following three options)

A. This facility was in compliance with all terms and conditions of the Title V Air Operation Permit and, if applicable, the Acid Rain Part, and there were no reportable incidents of deviations from applicable requirements associated with any malfunction or breakdown of process, fuel burning or emission control equipment, or monitoring systems during the reporting period identified above.

B. This facility was in compliance with all terms and conditions of the Title V Air Operation Permit and, if applicable, the Acid Rain Part; however, there were one or more reportable incidents of deviations from applicable requirements associated with malfunctions or breakdowns of process, fuel burning or emission control equipment, or monitoring systems during the reporting period identified above, which were reported to the Department. For each incident of deviation, the following information is included:

1. Date of report previously submitted identifying the incident of deviation.
2. Description of the incident.

C. This facility was in compliance with all terms and conditions of the Title V Air Operation Permit and, if applicable, the Acid Rain Part, EXCEPT those identified in the pages attached to this report and any reportable incidents of deviations from applicable requirements associated with malfunctions or breakdowns of process, fuel burning or emission control equipment, or monitoring systems during the reporting period identified above, which were reported to the Department. For each item of noncompliance, the following information is included:

1. Emissions unit identification number.
2. Specific permit condition number (note whether the permit condition has been added, deleted, or changed during certification period).
3. Description of the requirement of the permit condition.
4. Basis for the determination of noncompliance (for monitored parameters, indicate whether monitoring was continuous, i.e., recorded at least every 15 minutes, or intermittent).
5. Beginning and ending dates of periods of noncompliance.
6. Identification of the probable cause of noncompliance and description of corrective action or preventative measures implemented.
7. Dates of any reports previously submitted identifying this incident of noncompliance.

For each incident of deviation, as described in paragraph **B.** above, the following information is included:

1. Date of report previously submitted identifying the incident of deviation.
2. Description of the incident.

STATEMENT OF COMPLIANCE - TITLE V SOURCE

RESPONSIBLE OFFICIAL CERTIFICATION

I, the undersigned, am a responsible official (Title V air permit application or responsible official notification form on file with the Department) of the Title V source for which this document is being submitted. With respect to all matters other than Acid Rain program requirements, I hereby certify, based on the information and belief formed after reasonable inquiry, that the statements made and data contained in this document are true, accurate, and complete.

(Signature of Title V Source Responsible Official)

8/14/02
(Date)

Name: Roxane R. Kennedy

Title: General Plant Manager

DESIGNATED REPRESENTATIVE CERTIFICATION (only applicable to Acid Rain source)

I, the undersigned, am authorized to make this submission on behalf of the owners and operators of the Acid Rain source or Acid Rain units for which the submission is made. I certify under penalty of law that I have personally examined, and am familiar with, the statements and information submitted in this document and all its attachments. Based on my inquiry of those individuals with primary responsibility for obtaining the information, I certify that the statements and information are to the best of my knowledge and belief true, accurate, and complete. I am aware that there are significant penalties for submitting false statements and information or omitting required statements and information, including the possibility of fine or imprisonment.

(Signature of Acid Rain Source Designated Representative)

(Date)

Name: David W. Knutson

Title: Designated Representative

{Note: Attachments, if required, are created by a responsible official or designated representative, as appropriate, and should consist of the information specified and any supporting records. Additional information may also be attached by a responsible official or designated representative when elaboration is required for clarity. This report is to be submitted to both the compliance authority (DEP district or local air program) and the U.S. Environmental Protection Agency(EPA) (U.S. EPA Region 4, Air and EPCRA Enforcement Branch, 61 Forsyth Street, Atlanta GA 30303).}



Randy Hopkins

01/04/2002 11:58 AM

To: garry.kuberski@dep.state.fl.us
cc: John C Franklin/PGBU/FPL@FPL, Bruce Stuart@FPL
Subject: FPL Sanford Plant - opacity event 01/04/02

Garry,

As reported to your office this morning (01/04), at approximately 00:45 EST on January 4, 2002, Sanford Plant Unit 4 experienced six (6) six-minute average opacity emissions of 64%, 49%, 59%, 63%, 91% and 75% due to a controls malfunction.

At approximately 00:42 EST, the unit experienced a failure of the fuel oil flow transmitter. At the time, the unit was operating in a dual fuel (gas/oil) mode. The controls malfunction resulted in a fuel/air imbalance in the boiler creating the opacity. The control room operator took several steps to reduce opacity including reducing load and having an outside operator visually inspect the furnace. Upon the visual inspection, the outside operator noted that one of the burner guns did not appear to be operating correctly, and the burner gun was removed from service and replaced. However, that did not clear the opacity. The control room operator then removed all oil flow and converted the unit to 100% gas in addition to continuing to drop load. The high opacity then cleared and returned to normal operating levels.

Upon investigation it was determined that the primary fuel oil transmitter was bad. The control room operator then switched to the backup transmitter. Repairs to the primary transmitter are currently taking place.

Attached is an opacity and megawatt graph for the event.



U4020104.xls

If you need any more information, please contact me at (407) 575-5385.

Randy Hopkins



Randy Hopkins
02/28/2002 09:54 AM

To: garry.kuberski@dep.state.fl.us
cc: John C Franklin/PGBU/FPL@FPL, Bruce Stuart@FPL
Subject: FPL Sanford Plant - opacity event 02/28/02

Garry,

As reported to your office this morning (2/28), at approximately 06:45 EST on February 28, 2002, Sanford Plant Unit 4 experienced one six-minute average opacity emissions of 60% due to a malfunction.

At approximately 06:45 EST, the unit was increasing load due to cold weather demand when it experienced a burner gun malfunction. This resulted in a fuel/air imbalance in the boiler creating the opacity. The control room operator took several steps to reduce opacity including removing the unit from load control, increasing excess air, and having an outside operator visually inspect the furnace. Upon the visual inspection, the outside operator noted that one of the burner guns was not operating correctly. The burner gun was removed from service and replaced. When the burner gun was removed from service, the high opacity cleared and returned to normal operating levels.

Attached is an opacity and megawatt graph for the event.



U4020228.xls

If you need any more information, please contact me at (386) 575-5385.

Randy Hopkins



Randy Hopkins
05/01/2002 09:03 AM

To: Garry Kuberski
cc:
Subject: FPL Sanford Plant opacity event 04/30/02

Garry,

As reported to your office yesterday afternoon (4/30), at approximately 08:20 EST and 08:40 EST on April 30, 2002 Sanford Plant Unit 4 experienced two six-minute average opacity emissions of 45% and 51% due to a malfunction. (Please note that times are reported as standard time, not daylight savings time.)

At approximately 08:20 EST, the unit was increasing load when it experienced a burner gun malfunction. This resulted in a fuel/air imbalance in the boiler creating the opacity. The control room operator took several steps to reduce opacity including removing the unit from load control, increasing the excess air and cycling the burners to help identify the problem. When the operator determined which burner gun was not operating correctly, the gun was removed from service and replaced. The high-opacity then cleared and returned to normal operating levels.

Attached is an opacity and megawatt graph for the event.



U4020430.xls

If you need any more information, please contact me at (386) 575-5385.

Randy Hopkins



Randy Hopkins
05/03/2002 09:00 AM

To: Garry Kuberski
cc: John C Franklin/PGBU/FPL, Bruce Stuart, Fred Macklin
Subject: FPL Sanford Plant opacity event - 05/02/02

Garry,

As reported to your office this morning (5/03), at approximately 05:15 EST on May 02, 2002 Sanford Plant Unit 4 experienced three six-minute average opacity emissions of 88%, 86% and 63% due to a malfunction. (Please note that times are reported as standard time, not daylight savings time.)

At approximately 05:15 EST, the unit was near full load when it experienced a burner gun malfunction. This resulted in a fuel/air imbalance in the boiler creating the opacity. Due to high load demand, and a gas line rupture in north Florida and gas availability issues, the unit had been requested to be on 100% oil. When the control room operator experienced the high opacity, he took several steps to reduce opacity including reducing the load, increasing the excess air, and re-establishment of gas firing to the unit. Due to a malfunction of the gas regulator, gas firing was not able to be reestablished. The outside operator was able to identify the burner gun that was not operating correctly, and the gun was removed from service. The high opacity then cleared and returned to normal operating levels. The gas regulator has been repaired and the burner gun will be disassembled for inspection to identify the failure.

Attached is an opacity and megawatt graph for the event.



U4020502.xls

If you need any more information, please contact me at (386) 575-5385.

Randy Hopkins

III. EMISSIONS UNIT INFORMATION

A separate Emissions Unit Information Section (including subsections A through J as required) must be completed for each emissions unit addressed in this Application for Air Permit. If submitting the application form in hard copy, indicate, in the space provided at the top of each page, the number of this Emissions Unit Information Section and the total number of Emissions Unit Information Sections submitted as part of this application.

**A. GENERAL EMISSIONS UNIT INFORMATION
(All Emissions Units)**

Emissions Unit Description and Status

<p>1. Type of Emissions Unit Addressed in This Section: (Check one)</p> <p><input type="checkbox"/> This Emissions Unit Information Section addresses, as a single emissions unit, a single process or production unit, or activity, which produces one or more air pollutants and which has at least one definable emission point (stack or vent).</p> <p><input checked="" type="checkbox"/> This Emissions Unit Information Section addresses, as a single emissions unit, a group of process or production units and activities which has at least one definable emission point (stack or vent) but may also produce fugitive emissions.</p> <p><input type="checkbox"/> This Emissions Unit Information Section addresses, as a single emissions unit, one or more process or production units and activities which produce fugitive emissions only.</p>			
<p>2. Regulated or Unregulated Emissions Unit? (Check one)</p> <p><input checked="" type="checkbox"/> The emissions unit addressed in this Emissions Unit Information Section is a regulated emissions unit.</p> <p><input type="checkbox"/> The emissions unit addressed in this Emissions Unit Information Section is an unregulated emissions unit.</p>			
<p>3. Description of Emissions Unit Addressed in This Section (limit to 60 characters): Combustion Turbines 5A through 5D.</p>			
<p>4. Emissions Unit Identification Number: ID: 009-012</p> <p style="text-align: right;"><input type="checkbox"/> No ID <input type="checkbox"/> ID Unknown</p>			
<p>5. Emissions Unit Status Code: A</p>	<p>6. Initial Startup Date: FEB 2002</p>	<p>7. Emissions Unit Major Group SIC Code: 49</p>	<p>8. Acid Rain Unit? <input checked="" type="checkbox"/></p>
<p>9. Emissions Unit Comment: (Limit to 500 Characters)</p> <p>The emission units are four General Electric (E) Frame 7FA Advanced CTs. Unit 5 will fire natural gas and oil. It can be operated in only combined cycle mode. Nameplate ratings, heat input, emissions, etc., are the same for each CT. Connection for oil capability is not complete (see Attachment PSN-A9).</p>			

Emissions Unit Control Equipment

1. Control Equipment/Method Description (Limit to 200 characters per device or method):

Dry Low NO_x Combustors

2. Control Device or Method Code(s): **025, 028**

Emissions Unit Details

1. Package Unit:

Manufacturer: **General Electric**

Model Number: **7FA**

2. Generator Nameplate Rating:

182 MW

3. Incinerator Information:

Dwell Temperature:

°F

Dwell Time:

seconds

Incinerator Afterburner Temperature:

°F

**B. EMISSIONS UNIT CAPACITY INFORMATION
(Regulated Emissions Units Only)**

Emissions Unit Operating Capacity and Schedule

1. Maximum Heat Input Rate:	1776	mmBtu/hr
2. Maximum Incineration Rate:	lb/hr	tons/day
3. Maximum Process or Throughput Rate:		
4. Maximum Production Rate:		
5. Requested Maximum Operating Schedule:		
	hours/day	days/week
	weeks/year	8,760 hours/year
6. Operating Capacity/Schedule Comment (limit to 200 characters):		
<p>Maximum heat input for gas firing at turbine inlet temperature of 59 degrees Fahrenheit (°F), 60% relative humidity, 100% load and 14.7 psia. Heat input as High Heating Value (HHV). Maximum heat input for oil firing is 1,930 for the same conditions. Generator nameplate Rating - 182 MW (35°F turbine inlet).</p>		

**C. EMISSIONS UNIT REGULATIONS
(Regulated Emissions Units Only)**

List of Applicable Regulations

See Attachment PSNCT5A-5D_13

**D. EMISSION POINT (STACK/VENT) INFORMATION
(Regulated Emissions Units Only)**

Emission Point Description and Type

1. Identification of Point on Plot Plan or Flow Diagram? See Figure C-3		2. Emission Point Type Code: 3	
3. Descriptions of Emission Points Comprising this Emissions Unit for VE Tracking (limit to 100 characters per point): Unit can exhaust through HRSG stack.			
4. ID Numbers or Descriptions of Emission Units with this Emission Point in Common:			
5. Discharge Type Code: V	6. Stack Height: 125 feet	7. Exit Diameter: 19 feet	
8. Exit Temperature: 220 °F	9. Actual Volumetric Flow Rate: 1,196,162 acfm	10. Water Vapor: 7.6 %	
11. Maximum Dry Standard Flow Rate: 858,197 dscfm		12. Nonstack Emission Point Height: feet	
13. Emission Point UTM Coordinates: Zone: 17 East (km): 468.3 North (km): 3190.3			
14. Emission Point Comment (limit to 200 characters): Stack conditions for combined cycle operation and turbine inlet of 35°F. Stack conditions vary based on turbine inlet temperature and operating load and fuel (gas or oil firing). All CTs equipped with inlet foggers.			

**E. SEGMENT (PROCESS/FUEL) INFORMATION
(All Emissions Units)**

Segment Description and Rate: Segment 1 of 2

1. Segment Description (Process/Fuel Type) (limit to 500 characters): Natural Gas		
2. Source Classification Code (SCC): 2-01-002-01		3. SCC Units: Million Cubic Feet
4. Maximum Hourly Rate: 1.81	5. Maximum Annual Rate: 15,882	6. Estimated Annual Activity Factor:
7. Maximum % Sulfur:	8. Maximum % Ash:	9. Million Btu per SCC Unit: 1,024
10. Segment Comment (limit to 200 characters): Maximum Hourly Rate = 1,813 (rounded to 1.81) Max and Annual based on 35°F turbine inlet. Million Btu/SCC as HHV.		

Segment Description and Rate: Segment 2 of 2

1. Segment Description (Process/Fuel Type) (limit to 500 characters): Distillate Oil		
2. Source Classification Code (SCC): 2-01-001-01		3. SCC Units: Thousand Gallons Burned
4. Maximum Hourly Rate: 14.3	5. Maximum Annual Rate: 7,150	6. Estimated Annual Activity Factor:
7. Maximum % Sulfur: 0.05	8. Maximum % Ash:	9. Million Btu per SCC Unit: 138
10. Segment Comment (limit to 200 characters): Maximum Annual Rate based on 500 hours per year. SCC units as HHV.		

**F. EMISSIONS UNIT POLLUTANTS
(All Emissions Units)**

1. Pollutant Emitted	2. Primary Control Device Code	3. Secondary Control Device Code	4. Pollutant Regulatory Code
PM			WP
SO ₂			WP
NO _x	025	028	EL
CO			EL
VOC			EL

G. EMISSIONS UNIT POLLUTANT DETAIL INFORMATION
(Regulated Emissions Units -
Emissions-Limited and Preconstruction Review Pollutants Only)

Potential/Fugitive Emissions

1. Pollutant Emitted: PM		2. Total Percent Efficiency of Control:	
3. Potential Emissions: 17 lb/hour		4. Synthetically Limited? []	
		45.6 tons/year	
5. Range of Estimated Fugitive Emissions: [] 1 [] 2 [] 3 _____ to _____ tons/year			
6. Emission Factor: 17 lb/hr (oil firing) Reference: Golder, 1999.		7. Emissions Method Code: 2	
8. Calculation of Emissions (limit to 600 characters):			
9. Pollutant Potential/Fugitive Emissions Comment (limit to 200 characters): Lb/hr based on Air Construction Permit Application.			

Allowable Emissions Allowable Emissions 1 of 2

1. Basis for Allowable Emissions Code: OTHER		2. Future Effective Date of Allowable Emissions:	
3. Requested Allowable Emissions and Units: 10% Opacity		4. Equivalent Allowable Emissions: 10 lb/hour 43.8 tons/year	
5. Method of Compliance (limit to 60 characters): EPA Method 9			
6. Allowable Emissions Comment (Desc. of Operating Method) (limit to 200 characters): Gas firing. Air Construction Permit 1270009-004-AC and PSD-FL-270.			

G. EMISSIONS UNIT POLLUTANT DETAIL INFORMATION
(Regulated Emissions Units -
Emissions-Limited and Preconstruction Review Pollutants Only)

Potential/Fugitive Emissions

1. Pollutant Emitted: PM	2. Total Percent Efficiency of Control:
3. Potential Emissions: lb/hour _____ tons/year _____	4. Synthetically Limited? <input type="checkbox"/>
5. Range of Estimated Fugitive Emissions: [] 1 [] 2 [] 3 _____ to _____ tons/year	
6. Emission Factor: Reference:	7. Emissions Method Code:
8. Calculation of Emissions (limit to 600 characters):	
9. Pollutant Potential/Fugitive Emissions Comment (limit to 200 characters):	

Allowable Emissions Allowable Emissions 2 of 2

1. Basis for Allowable Emissions Code: OTHER	2. Future Effective Date of Allowable Emissions:
3. Requested Allowable Emissions and Units: 20% Opacity	4. Equivalent Allowable Emissions: 10 lb/hour 43.8 tons/year
5. Method of Compliance (limit to 60 characters):	
6. Allowable Emissions Comment (Desc. of Operating Method) (limit to 200 characters): Oil firing. Air Construction Permit 1270009-004-AC and PSD-FL-270.	

G. EMISSIONS UNIT POLLUTANT DETAIL INFORMATION
(Regulated Emissions Units -
Emissions-Limited and Preconstruction Review Pollutants Only)

Potential/Fugitive Emissions

1. Pollutant Emitted: SO₂		2. Total Percent Efficiency of Control:	
3. Potential Emissions: 101.5 lb/hour		4. Synthetically Limited? []	
		46.6 tons/year	
5. Range of Estimated Fugitive Emissions: [] 1 [] 2 [] 3 _____ to _____ tons/year			
6. Emission Factor: 1 grain S/100 cf Gas; 0.05% S Oil Reference: Golder, 1999.		7. Emissions Method Code: 2	
8. Calculation of Emissions (limit to 600 characters):			
9. Pollutant Potential/Fugitive Emissions Comment (limit to 200 characters): Lb/hr and ton/year based on Air Construction Permit Application.			

Allowable Emissions Allowable Emissions 1 of 2

1. Basis for Allowable Emissions Code: OTHER		2. Future Effective Date of Allowable Emissions:	
3. Requested Allowable Emissions and Units:		4. Equivalent Allowable Emissions: 5.1 lb/hour 22.5 tons/year	
5. Method of Compliance (limit to 60 characters): Fuel sampling; vendor sampling pipeline quality natural gas			
6. Allowable Emissions Comment (Desc. of Operating Method) (limit to 200 characters): Requested Allowable Emissions and Units = pipeline quality natural gas. Allowable based on typical maximum fuel sulfur content. Air Construction Permit 1270009-004-AC and PSD-FL-270.			

G. EMISSIONS UNIT POLLUTANT DETAIL INFORMATION
(Regulated Emissions Units -
Emissions-Limited and Preconstruction Review Pollutants Only)

Potential/Fugitive Emissions

1. Pollutant Emitted: SO₂		2. Total Percent Efficiency of Control:	
3. Potential Emissions: lb/hour		4. Synthetically Limited? []	
5. Range of Estimated Fugitive Emissions: [] 1 [] 2 [] 3 _____ to _____ tons/year			
6. Emission Factor: Reference:		7. Emissions Method Code:	
8. Calculation of Emissions (limit to 600 characters):			
9. Pollutant Potential/Fugitive Emissions Comment (limit to 200 characters):			

Allowable Emissions Allowable Emissions 2 of 2

1. Basis for Allowable Emissions Code: OTHER		2. Future Effective Date of Allowable Emissions:	
3. Requested Allowable Emissions and Units: 0.05% Sulfur		4. Equivalent Allowable Emissions: 101.5 lb/hour 24.5 tons/year	
5. Method of Compliance (limit to 60 characters): Fuel sampling; vendor sampling			
6. Allowable Emissions Comment (Desc. of Operating Method) (limit to 200 characters): Allowable based on typical maximum fuel sulfur content. Air Construction Permit 1270009-004-AC and PSD-FL-270.			

G. EMISSIONS UNIT POLLUTANT DETAIL INFORMATION
(Regulated Emissions Units -
Emissions-Limited and Preconstruction Review Pollutants Only)

Potential/Fugitive Emissions

1. Pollutant Emitted: NO_x	2. Total Percent Efficiency of Control:
3. Potential Emissions: 365.2 lb/hour 372.2 tons/year	4. Synthetically Limited? [<input type="checkbox"/>]
5. Range of Estimated Fugitive Emissions: [] 1 [] 2 [] 3 _____ to _____ tons/year	
6. Emission Factor: 42/9 ppmvd @ 15% O₂ Reference: Golder, 1999.	7. Emissions Method Code: 2
8. Calculation of Emissions (limit to 600 characters): Emission Factor = Oil/Gas Firing	
9. Pollutant Potential/Fugitive Emissions Comment (limit to 200 characters): Lb/hr and tons/year based on Air Construction Permit Application.	

Allowable Emissions Allowable Emissions 1 of 2

1. Basis for Allowable Emissions Code: OTHER	2. Future Effective Date of Allowable Emissions:
3. Requested Allowable Emissions and Units: 9 ppmvd @ 15% O₂	4. Equivalent Allowable Emissions: 68 lb/hour 297.8 tons/year
5. Method of Compliance (limit to 60 characters): CEM - Part 75	
6. Allowable Emissions Comment (Desc. of Operating Method) (limit to 200 characters): Gas firing allowable emissions are a 30-day rolling average. Air Construction Permit 1270009-004-AC and PSD-FL-270. CEM is installed in HRSG stack.	

G. EMISSIONS UNIT POLLUTANT DETAIL INFORMATION
(Regulated Emissions Units -
Emissions-Limited and Preconstruction Review Pollutants Only)

Potential/Fugitive Emissions

1. Pollutant Emitted: NO_x	2. Total Percent Efficiency of Control:
3. Potential Emissions: lb/hour _____ tons/year _____	4. Synthetically Limited? []
5. Range of Estimated Fugitive Emissions: [] 1 [] 2 [] 3 _____ to _____ tons/year	
6. Emission Factor: Reference:	7. Emissions Method Code:
8. Calculation of Emissions (limit to 600 characters):	
9. Pollutant Potential/Fugitive Emissions Comment (limit to 200 characters):	

Allowable Emissions Allowable Emissions 2 of 2

1. Basis for Allowable Emissions Code: OTHER	2. Future Effective Date of Allowable Emissions:
3. Requested Allowable Emissions and Units: 42 ppmvd @ 15% O₂	4. Equivalent Allowable Emissions: 365.2 lb/hour 91.3 tons/year
5. Method of Compliance (limit to 60 characters): CEM - Part 75	
6. Allowable Emissions Comment (Desc. of Operating Method) (limit to 200 characters): Allowable emissions are a 24-hour block average. Air Construction Permit 1270009-004-AC and PSD-FL-270. CEM is installed in HRSG stack.	

**G. EMISSIONS UNIT POLLUTANT DETAIL INFORMATION
(Regulated Emissions Units -
Emissions-Limited and Preconstruction Review Pollutants Only)**

Potential/Fugitive Emissions

1. Pollutant Emitted: CO		2. Total Percent Efficiency of Control:	
3. Potential Emissions: 75.1 lb/hour 204.2 tons/year		4. Synthetically Limited? <input type="checkbox"/>	
5. Range of Estimated Fugitive Emissions: [] 1 [] 2 [] 3 _____ to _____ tons/year			
6. Emission Factor: 20/12 ppmvd Reference: Golder, 1999.		7. Emissions Method Code: 2	
8. Calculation of Emissions (limit to 600 characters): Emission Factor = Oil/Gas Firing			
9. Pollutant Potential/Fugitive Emissions Comment (limit to 200 characters): Lb/hr and tons/year based on Air Construction Permit Application.			

Allowable Emissions Allowable Emissions 1 of 2

1. Basis for Allowable Emissions Code: OTHER		2. Future Effective Date of Allowable Emissions:	
3. Requested Allowable Emissions and Units: 12 ppmvd		4. Equivalent Allowable Emissions: 44.9 lb/hour 196.6 tons/year	
5. Method of Compliance (limit to 60 characters): EPA Method 10; Annual Test			
6. Allowable Emissions Comment (Desc. of Operating Method) (limit to 200 characters): Gas firing. Air Construction Permit 1270009-004-AC and PSD-FL-270.			

G. EMISSIONS UNIT POLLUTANT DETAIL INFORMATION
(Regulated Emissions Units -
Emissions-Limited and Preconstruction Review Pollutants Only)

Potential/Fugitive Emissions

1. Pollutant Emitted: CO		2. Total Percent Efficiency of Control:	
3. Potential Emissions: lb/hour _____ tons/year _____		4. Synthetically Limited? []	
5. Range of Estimated Fugitive Emissions: [] 1 [] 2 [] 3 _____ to _____ tons/year			
6. Emission Factor: Reference:		7. Emissions Method Code:	
8. Calculation of Emissions (limit to 600 characters):			
9. Pollutant Potential/Fugitive Emissions Comment (limit to 200 characters):			

Allowable Emissions Allowable Emissions 2 of 2

1. Basis for Allowable Emissions Code: OTHER		2. Future Effective Date of Allowable Emissions:	
3. Requested Allowable Emissions and Units: 20 ppmvd		4. Equivalent Allowable Emissions: 75.1 lb/hour 18.8 tons/year	
5. Method of Compliance (limit to 60 characters): EPA Method 10; Annual Test			
6. Allowable Emissions Comment (Desc. of Operating Method) (limit to 200 characters): Oil firing. Air Construction Permit 1270009-004-AC and PSD-FL-270.			

G. EMISSIONS UNIT POLLUTANT DETAIL INFORMATION
(Regulated Emissions Units -
Emissions-Limited and Preconstruction Review Pollutants Only)

Potential/Fugitive Emissions

1. Pollutant Emitted: VOC		2. Total Percent Efficiency of Control:	
3. Potential Emissions: 16.9 lb/hour		4. Synthetically Limited? [<input type="checkbox"/>]	
		16.6 tons/year	
5. Range of Estimated Fugitive Emissions: [] 1 [] 2 [] 3 _____ to _____ tons/year			
6. Emission Factor: 7 ppmvw/1.4 ppmvd Reference: Golder, 1999.		7. Emissions Method Code: 2	
8. Calculation of Emissions (limit to 600 characters): Emission Factor = Oil/Gas			
9. Pollutant Potential/Fugitive Emissions Comment (limit to 200 characters): Lb/hr and tons/year based on Air Construction Permit Application.			

Allowable Emissions Allowable Emissions 1 of 2

1. Basis for Allowable Emissions Code: OTHER		2. Future Effective Date of Allowable Emissions:	
3. Requested Allowable Emissions and Units: 7 ppmvw		4. Equivalent Allowable Emissions: 3 lb/hour 13.1 tons/year	
5. Method of Compliance (limit to 60 characters): EPA Method 18 or 25A; Initial Compliance Test only			
6. Allowable Emissions Comment (Desc. of Operating Method) (limit to 200 characters): Gas firing. Air Construction Permit 1270009-004-AC and PSD-FL-270.			

H. VISIBLE EMISSIONS INFORMATION
 (Only Regulated Emissions Units Subject to a VE Limitation)

Visible Emissions Limitation: Visible Emissions Limitation 1 of 3

1. Visible Emissions Subtype: VE10	2. Basis for Allowable Opacity: [] Rule [<input checked="" type="checkbox"/>] Other
3. Requested Allowable Opacity: Normal Conditions: 10 % Exceptional Conditions: % Maximum Period of Excess Opacity Allowed: min/hour	
4. Method of Compliance: Annual VE Test - EPA Method 9.	
5. Visible Emissions Comment (limit to 200 characters): Gas Firing	

I. CONTINUOUS MONITOR INFORMATION
 (Only Regulated Emissions Units Subject to Continuous Monitoring)

Continuous Monitoring System: Continuous Monitor 1 of 1

1. Parameter Code: EM	2. Pollutant(s): NO_x
3. CMS Requirement: [<input checked="" type="checkbox"/>] Rule [] Other	
4. Monitor Information: Manufacturer: NO_x = Thermo Environmental Instruments; O₂ = Servomex Model Number: NO_x = 43CHL; O₂ = 1400 Serial Number: NO_x O₂ 5A= 42CHL-68655-361 01420C/1831 5B= 42CHL-68660-361 01420C/1832 5C= 42CHL-68659-361 01420C/1833 5D= 42CHL-68661-361 01420C/1834	
5. Installation Date: 1 JAN 2002 (5A) through 30 APR 2002 (5D)	6. Performance Specification Test Date: 08 MAY 2002 (5A); 10 MAY 2002 (5B); 10 MAY 2002 (5C); 09 MAY 2002 (5D)
7. Continuous Monitor Comment (limit to 200 characters):	

H. VISIBLE EMISSIONS INFORMATION
(Only Regulated Emissions Units Subject to a VE Limitation)

Visible Emissions Limitation: Visible Emissions Limitation 2 of 3

1. Visible Emissions Subtype: VE99	2. Basis for Allowable Opacity: <input checked="" type="checkbox"/> Rule <input type="checkbox"/> Other
3. Requested Allowable Opacity: Normal Conditions: % Exceptional Conditions: 100 % Maximum Period of Excess Opacity Allowed: 60 min/hour	
4. Method of Compliance: None	
5. Visible Emissions Comment (limit to 200 characters): FDEP Rule 62-210.700(1). Allowed for 2 hours (120 minutes) per 24 hours for start-up, shutdown, and malfunction.	

I. CONTINUOUS MONITOR INFORMATION
(Only Regulated Emissions Units Subject to Continuous Monitoring)

Continuous Monitoring System: Continuous Monitor _____ of _____

1. Parameter Code:	2. Pollutant(s):
3. CMS Requirement:	<input type="checkbox"/> Rule <input type="checkbox"/> Other
4. Monitor Information: Manufacturer: Model Number: Serial Number:	
5. Installation Date:	6. Performance Specification Test Date:
7. Continuous Monitor Comment (limit to 200 characters): 	

H. VISIBLE EMISSIONS INFORMATION
 (Only Regulated Emissions Units Subject to a VE Limitation)

Visible Emissions Limitation: Visible Emissions Limitation 3 of 3

1. Visible Emissions Subtype: VE20	2. Basis for Allowable Opacity: <input type="checkbox"/> Rule <input checked="" type="checkbox"/> Other
3. Requested Allowable Opacity: Normal Conditions: 20 % Exceptional Conditions: % Maximum Period of Excess Opacity Allowed: min/hour	
4. Method of Compliance: Annual VE Test - EPA Method 9.	
5. Visible Emissions Comment (limit to 200 characters): Oil Firing	

I. CONTINUOUS MONITOR INFORMATION
 (Only Regulated Emissions Units Subject to Continuous Monitoring)

Continuous Monitoring System: Continuous Monitor _____ of _____

1. Parameter Code:	2. Pollutant(s):
3. CMS Requirement:	<input type="checkbox"/> Rule <input type="checkbox"/> Other
4. Monitor Information: Manufacturer: Model Number: Serial Number:	
5. Installation Date:	6. Performance Specification Test Date:
7. Continuous Monitor Comment (limit to 200 characters):	

**J. EMISSIONS UNIT SUPPLEMENTAL INFORMATION
(Regulated Emissions Units Only)**

Supplemental Requirements

1. Process Flow Diagram <input checked="" type="checkbox"/> Attached, Document ID: <u>Figure C-3</u> <input type="checkbox"/> Not Applicable <input type="checkbox"/> Waiver Requested
2. Fuel Analysis or Specification <input checked="" type="checkbox"/> Attached, Document ID: <u>Tables 2-2A & 2-2B</u> <input type="checkbox"/> Not Applicable <input type="checkbox"/> Waiver Requested
3. Detailed Description of Control Equipment <input checked="" type="checkbox"/> Attached, Document ID: <u>GER-3568F</u> <input type="checkbox"/> Not Applicable <input type="checkbox"/> Waiver Requested
4. Description of Stack Sampling Facilities <input checked="" type="checkbox"/> Attached, Document ID: <u>PSNCT5A-5Dstack</u> <input type="checkbox"/> Not Applicable <input type="checkbox"/> Waiver Requested
5. Compliance Test Report <input type="checkbox"/> Attached, Document ID: _____ <input checked="" type="checkbox"/> Previously submitted, Date: <u>5A, 5C, and 5D - 13 JUN 2002; 5B - 07 JUN 2002</u> <input type="checkbox"/> Not Applicable
6. Procedures for Startup and Shutdown <input checked="" type="checkbox"/> Attached, Document ID: <u>PSNCT5A-5D 6</u> <input type="checkbox"/> Not Applicable <input type="checkbox"/> Waiver Requested
7. Operation and Maintenance Plan <input type="checkbox"/> Attached, Document ID: _____ <input checked="" type="checkbox"/> Not Applicable <input type="checkbox"/> Waiver Requested
8. Supplemental Information for Construction Permit Application <input type="checkbox"/> Attached, Document ID: _____ <input checked="" type="checkbox"/> Not Applicable
9. Other Information Required by Rule or Statute <input type="checkbox"/> Attached, Document ID: _____ <input checked="" type="checkbox"/> Not Applicable
10. Supplemental Requirements Comment:

Additional Supplemental Requirements for Title V Air Operation Permit Applications

11. Alternative Methods of Operation [X] Attached, Document ID: <u>PSNCT5A-5D_12</u> [] Not Applicable
12. Alternative Modes of Operation (Emissions Trading) [] Attached, Document ID: _____ [X] Not Applicable
13. Identification of Additional Applicable Requirements [X] Attached, Document ID: <u>PSNFS_9</u> [] Not Applicable
14. Compliance Assurance Monitoring Plan [] Attached, Document ID: _____ [X] Not Applicable
15. Acid Rain Part Application (Hard-copy Required) [X] Acid Rain Part - Phase II (Form No. 62-210.900(1)(a)) Attached, Document ID: <u>PSNCT5A-5D_15</u> [] Repowering Extension Plan (Form No. 62-210.900(1)(a)1.) Attached, Document ID: _____ [] New Unit Exemption (Form No. 62-210.900(1)(a)2.) Attached, Document ID: _____ [] Retired Unit Exemption (Form No. 62-210.900(1)(a)3.) Attached, Document ID: _____ [] Phase II NOx Compliance Plan (Form No. 62-210.900(1)(a)4.) Attached, Document ID: _____ [] Phase NOx Averaging Plan (Form No. 62-210.900(1)(a)5.) Attached, Document ID: _____ [] Not Applicable

ATTACHMENT PSN-A9
EMISSIONS UNIT COMMENT



Typical HRSG Stack



Wet Surface Air Cooler (Unit 5). Unit 5B stack in background.

Attachment PSN-A9
Site Photographs

Source: Golder, 2002.



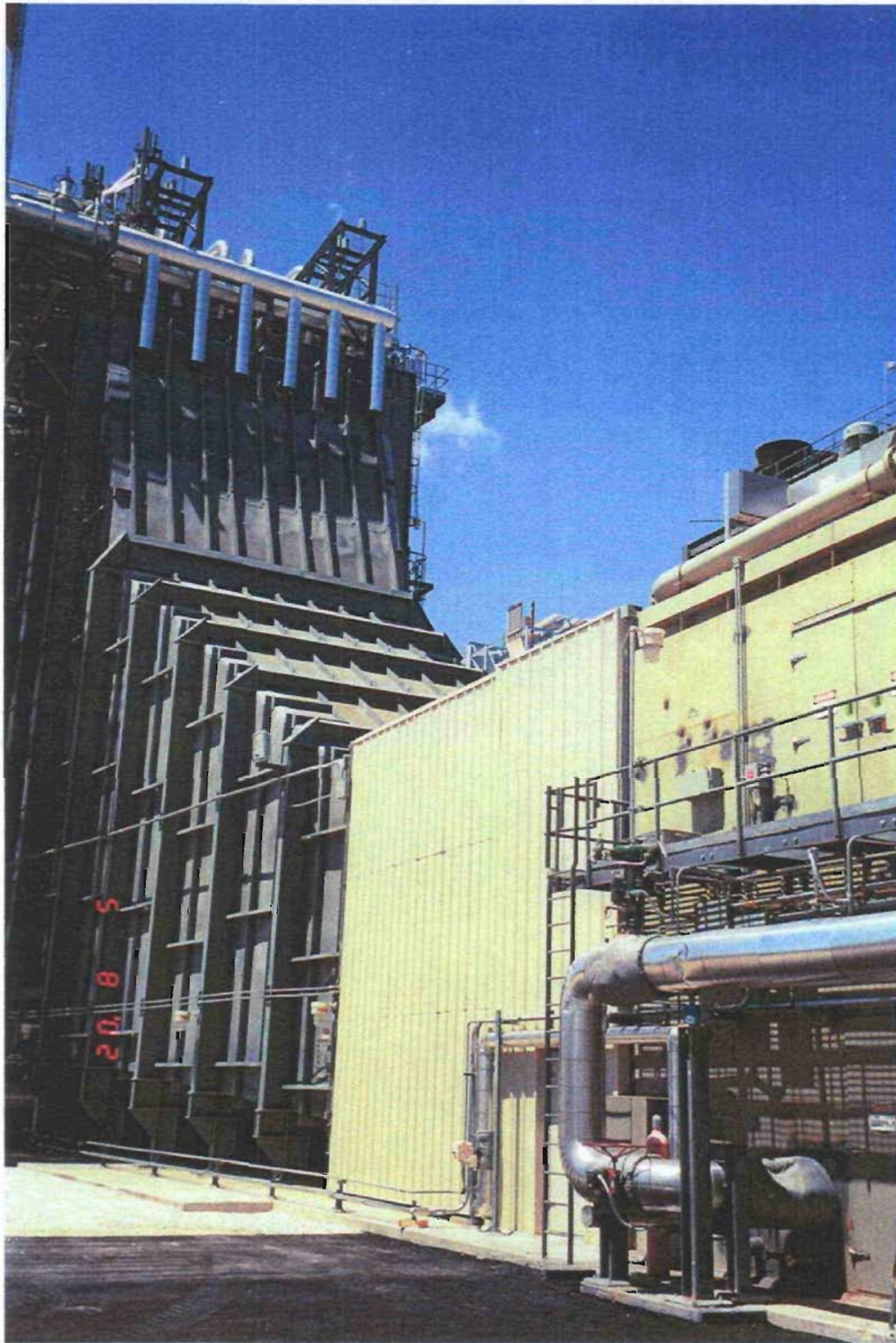

Unit 5A CT Exhaust/HRSG Inlet

Attachment PSN-A9
Site Photographs

Source: Golder, 2002.





Unit 5A Inlet Fogger Skid



Unit 5A CEM Shelter

Attachment PSN-A9
Site Photographs

Source: Golder, 2002.





Unit 5A Electric Gas Heater (used for startup)



Unit 5A Steam Gas Heater

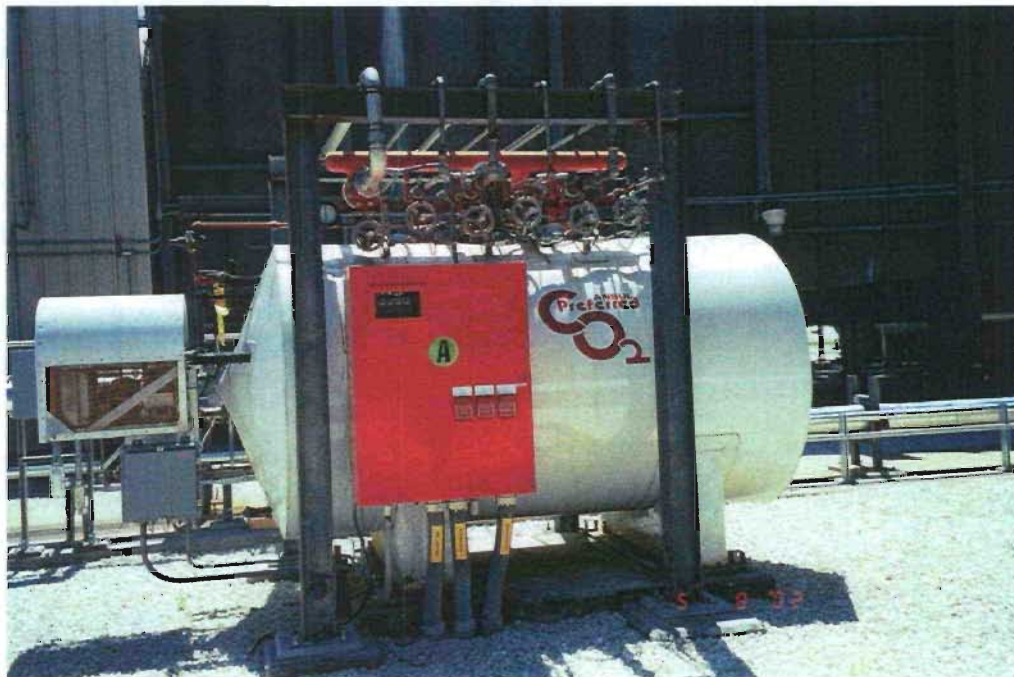

Unit 5A Fire Protection System

Attachment PSN-A9
Site Photographs

Source: Golder, 2002.



TABLES 2-2A & 2-2B
FUEL ANALYSIS OR SPECIFICATION

Table 2-2A. Representative Natural Gas Specification for Sanford Repowering Project

Compound	Percent by Volume	Percent by Weight
Methane (CH ₄)	95.873	91.45
Ethane (C ₂ H ₆)	2.579	4.61
Propane (C ₃ H ₈)	0.161	0.042
Butane (C ₄ H ₁₀)	0.017	0.06
Pentane (C ₅ H ₁₂)	0.007	0.03
Hexane (C ₆ H ₁₄)	0.027	0.14
Carbon Dioxide (CO ₂)	0.883	2.53
Nitrogen (N ₂)	0.453	0.76
Total Sulfur (S)	1 gr/100 scf ^a	–
Water Vapor (H ₂ O)	0.6 lb/MMscf	–

Note: HHV = 23,006 Btu/lb = 1,024 Btu/scf [60°F @ 14.7 pounds per square inch (psi)].

LHV = 20,751 Btu/lb = 924 Btu/scf (60°F @ 14.7 psi).

^aTypical maximum.

Table 2-2B. Representative Fuel Oil Specification for Sanford Repowering Project

Parameter	Specification
Specific Gravity, 60°F	0.82 - 0.86
Heating Value (HHV)	19,398 Btu/lb
Carbon	87% by weight
Oxygen	0% by weight
Sulfur	0.05% (maximum) by weight
Nitrogen	<0.015 by weight
Hydrogen	12.5% by weight
Ash	0.01% (maximum) by weight
Water and Sediment	0.05% (maximum) by volume
Trace metal contaminants (untreated)	
Sodium plus potassium	0.5 ppm (maximum)
Vanadium	0.5 ppm (maximum)
Lead	0.5 ppm (maximum)
Calcium	0.5 ppm (maximum)

Note: Btu/lb = British thermal units per pound.

ppm = parts per million.

HHV = High heating value.

Source: ASTM D2880-94

ATTACHMENT GER-3568F
DETAILED DESCRIPTION OF CONTROL EQUIPMENT



GE Power Generation

Dry Low NO_x Combustion Systems for GE Heavy-Duty Gas Turbines

L. Berkley Davis
GE Power Systems
Schenectady, NY

LIST OF FIGURES

- Figure 1. Dry Low NO_x product plan
- Figure 2. DLN power augmentation summary — gas fuel
- Figure 3. DLN peak firing summary — gas fuel
- Figure 4. DLN technology — a four-sided box
- Figure 5. DLN-1 combustor schematic
- Figure 6. Fuel-staged Dry Low NO_x operating modes
- Figure 7. Typical Dry Low NO_x fuel gas split schedule
- Figure 8. DLN-1 gas fuel system
- Figure 9. MS7001EA/MS9001E DLN-1 combustion system performance on natural gas fuel
- Figure 10. MS6001B DLN-1 emissions performance on natural gas fuel
- Figure 11. MS7001EA/MS9001E DLN-1 combustion system performance on distillate oil
- Figure 12. MS6001B DLN-1 emissions performance on distillate oil fuel
- Figure 13. DLN-2 combustion system
- Figure 14. Cross-section of a DLN-2 fuel nozzle
- Figure 15. External view of DLN-2 fuel nozzles mounted on end cover
- Figure 16. Fuel flow scheduling associated with DLN-2 operation
- Figure 17. DLN-2 gas fuel system
- Figure 18. Emissions performance for DLN-2-equipped 7FA/9FA for gas fuel
- Figure 19. Emissions performance for DLN-2 equipped 7FA/9FA for oil fuel with water injection
- Figure A1. MS7001EA Dry Low NO_x combustion chamber
- Figure A2. Exploded view of combustion chamber
- Figure A3. Rate of thermal NO_x production
- Figure A4. Staged combustors

DRY LOW NO_x COMBUSTION SYSTEMS FOR GE HEAVY-DUTY GAS TURBINES

L.B. Davis
GE Power Systems
Schenectady, NY

ABSTRACT

State-of-the-art emissions control technology for heavy-duty gas turbines is reviewed with emphasis on the operating characteristics and field experience of Dry Low NO_x (DLN) combustors for E- and F- technology machines. The lean premixed DLN systems for gas fuel have demonstrated their ability to meet the ever-lower emission levels required today. Lean premixed technology has also been demonstrated on oil fuel and is also discussed.

INTRODUCTION

The regulatory requirements for low emissions from gas turbine power plants have increased during the past 10 years. Environmental agencies throughout the world are now requiring even lower rates of emissions of NO_x and other pollutants from both new and existing gas turbines. Traditional methods of reducing NO_x emissions from combustion turbines (water and steam injection) are limited in their ability to reach the extremely low levels required in many localities. GE's involvement in the development of both the traditional methods (References 1 through 6) and the newer Dry Low NO_x (DLN) technology (References 7 and 8) has been well-documented. This paper focuses on DLN.

Since the commercial introduction of GE's DLN combustion systems for natural-gas-fired heavy-duty gas turbines in 1991, systems have been installed in more than 145 machines, from the most modern F technology (firing temperature class of 2400 F/1316 C) to field retrofits of older machines. As of August 1996, these machines have operated more than one million hours with DLN; more than 290,000 hours have been in the F technology. To meet marketplace demands, GE has developed DLN products broadly classified as either DLN-1, which was developed for E-technology (2000 F/1093 C firing temperature class) machines, or DLN-2, which was developed specifically for the F technology machines and is also being applied to the EC, G and H machines.

Development of these products has required an intensive engineering effort involving both GE Power Systems and GE Corporate Research and Development. This collaboration will continue as DLN is applied to the G and H machines and combustor development for Dry Low NO_x on oil ("dry oil") continues.

This paper presents the current status of DLN-1 technology and experience, including dry oil, and of DLN-2 technology and experience. Background information about gas turbine emissions and emissions control is contained in the Appendix.

DRY LOW NO_x SYSTEMS

Dry Low NO_x Product Plan

Figure 1 shows GE's Dry Low NO_x product offerings for its new and existing machines in three major groupings. The first group includes the MS3000, MS5000 and MS6001B products. The 6B DLN-1 is the technology flagship product for this group and, as can be noted, is available to meet 9 ppm NO_x requirements. Such low NO_x emissions are generally not attainable on lower firing temperature machines such as the MS3000s and MS5000s because carbon monoxide (CO) would be excessive.

The second major group includes the MS7000B/E, MS7001EA and MS9001E machines with the 9 ppm 7EA DLN-1 as the flagship product. The dry oil program focuses initially on this group.

The third group combines all of the DLN-2 products and includes the FA, EC, G and H machines, with the 7FA product as the flagship.

As shown in Figures 2 and 3, most of these products are capable of power augmentation and of peak firing with increased NO_x emissions. With gas fuel, power augmentation with steam is in the premixed mode for both DLN-1 and DLN-2 systems. Power augmentation with water is in the lean-lean mode for DLN-1 and in the premixed mode for DLN-2.

The GE DLN systems integrate a staged pre-

Turbine Model	Gas			Distillate		
	NO _x (ppmvd)	CO (ppmvd)	Diluent	NO _x (ppmvd)	CO (ppmvd)	Diluent
MS3002 (J) - RC	33	25	Dry	Not Available		
MS3002 (J) - SC	42	50	Dry	Not Available		
MS5001P	42	50	Dry	65	20	Water
MS5001R	42	50	Dry	65	20	Water
MS5002C	42	50	Dry	65	20	Water
MS6001 B	25	15	Dry	42	20	Water
	9	25	Dry	42	30	Water/Steam
MS6001 FA	25	15	Dry	42/65	20	Water/Steam
MS7001 B/E Conv	25	25	Dry	42	30	Water
MS7001 EA	25	15	Dry	42	20	Water
	15	25	Dry	42	30	Water/Steam
	9	25	Dry	42	30	Water/Steam
MS7001 EC	25	15	Dry	42/65	20	Water/Steam
MS7001 FA	25	15	Dry	42/65	20	Water/Steam
	9	9	Dry	42/65	30	Water/Steam
MS9001 E	35	15	Dry	42	20	Water
	25	25	Dry	42	20	Water
	25	25	Dry	90	20	Dry
MS7001 H	25	15	Dry	42/65	20	Water/Steam
	9	9	Dry	42/65	30	Water/Steam
MS9001 EC	25	15	Dry	42/65	20	Water/Steam
MS9001 FA	25	15	Dry	42/65	20	Water/Steam
MS9001 H	25	15	Dry	42/65	20	Water/Steam

Notes: 1. NO_x levels are at 15% oxygen. Ambient range 30 F/-1 C to 100 F/38 C

GT247170

Figure 1. Dry Low NO_x product plan

mixed combustor, the gas turbine's SPEEDTRONIC™ controls and the fuel and associated systems. There are two principal measures of performance. The first is meeting the emission levels required at base load on both gas and oil fuel and controlling the variation of these levels across the load range of the gas turbine.

The second measure is system operability, with emphasis placed on the smoothness and reliability of combustor mode changes, ability to load and unload the machine without restriction, capability to switch from one fuel to another

and back again, and system response to rapid transients (e.g., generator breaker open events or rapid swings in load). GE's design goal is to make the DLN system operate so the gas turbine operator does not know whether a DLN or conventional combustion system is installed (i.e., its operation is "transparent to the user"). As of August 1996, a significant portion of the DLN design and development effort has focused on system operability.

Design of a successful DLN combustor for a heavy-duty gas turbine also requires the designer to develop hardware features and operational

Turbine Model	NO _x @15% O ₂ (ppmvd)	Operating Mode	Diluent	Maximum Diluent/Fuel	NO _x at Max D/F (ppmvd)	CO Max D/F (ppmvd)
MS6001(B)	9	Premix	Steam	2.5/1	9	25
		Lean-Lean	Steam	2.5/1	25	15
	25	Premix	Steam	2.5/1	25	15
MS7001(EA)	9	Lean-Lean	Water	1.5/1	25	15
		Lean-Lean	Steam	2.5/1	25	15
		Lean-Lean	Steam	2.5/1	25	15
	25	Premix	Steam	2.5/1	25	15
		Lean-Lean	Water	1.5/1	25	15
		Lean-Lean	Steam	2.5/1	25	15
MS7001(FA)	25	Premix	Steam	2.1/1	25	15

GT24556

Figure 2. DLN power augmentation summary — gas fuel

	NO _x -Base (ppmvd)	NO _x -Peak (ppmvd)	CO-Base (ppmvd)	CO-Peak (ppmvd)
MS6001(B)	9	18	25	6
	25	50	15	4
MS7001(EA)	9	18	25	6
	25	50	15	4
MS7001(FA)	25	35	15	6
MS9001(E)	25	40	15	6

GT24557

Figure 3. DLN peak firing summary — gas fuel

methods that simultaneously allow the equivalence ratio and residence time in the flame zone to be low enough to achieve low NO_x, but with acceptable levels of combustion noise (dynamics), stability at part load operation and sufficient residence time for CO burn-out, hence the designation of DLN combustion design as “four-sided box” (Figure 4).

A scientific and engineering development program by GE’s Corporate Research and Development Center, Power Systems business and Aircraft Engine business has focused on understanding and controlling dynamics in lean premixed flows. The objectives have been to:

- Gather and analyze machine and laboratory data to create a comprehensive dynamics data base
- Create analytical models of gas turbine combustion systems that can be used to understand dynamics behavior

- Use the analytical models and experimental methods to develop methods to control dynamics

As of August 1996, these efforts have resulted in a large number of hardware and control features that limit dynamics, plus analytical tools that are used to predict system behavior. The latter are particularly useful in correlating laboratory test data from full scale combustors with actual gas turbine data.

DLN-1 System

DLN-1 development began in the 1970s with the goal of producing a dry oil system to meet the United States Environmental Protection Agency’s New Source Performance Standards of 75 ppmvd NO_x at 15% O₂. As noted in Reference 7, this system was tested on both oil and gas fuel at Houston Lighting & Power in

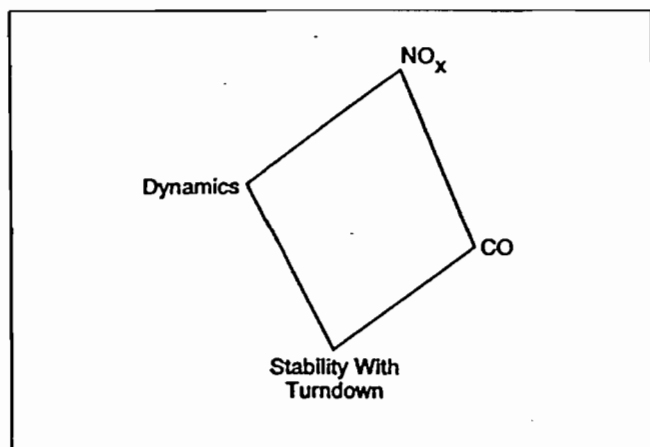

GT23812A

Figure 4. DLN technology — a four-sided box

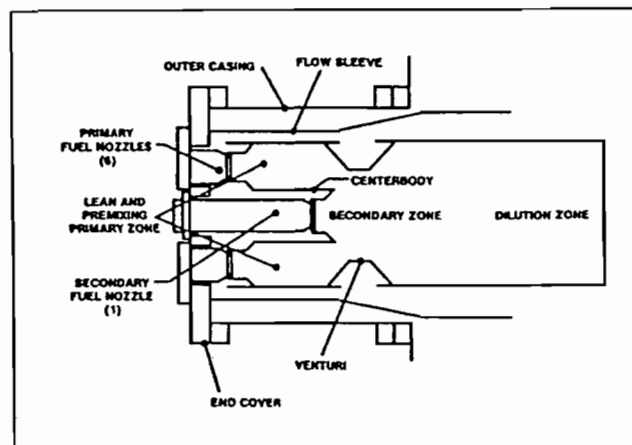

GT15050A

Figure 5. DLN-1 combustor schematic

1980 and met its emission goals. Subsequent to this, DLN program goals changed in response to stricter environmental regulations and the pace of the program accelerated in the late 1980s.

DLN-1 Combustor

The GE DLN-1 combustor (shown in cross section in Figure 5 and described in Reference 8) is a two-stage premixed combustor designed for use with natural gas fuel and capable of operation on liquid fuel. As shown, the combustion system includes four major components: fuel injection system, liner, venturi and cap/centerbody assembly.

These components form two stages in the combustor. In the premixed mode, the first stage thoroughly mixes the fuel and air and delivers a uniform, lean, unburned fuel-air mixture to the second stage.

The GE DLN-1 combustion system operates in four distinct modes, illustrated in Figure 6, during pre-mixed natural gas or oil fuel operation:

Mode	Operating Range
Primary	Fuel only to the primary nozzles. Flame is in the primary stage only. This mode of operation is used to ignite, accelerate and operate the machine over low- to mid-loads, up to a preselected combustion reference temperature.
Lean-Lean	Fuel to both the primary and secondary nozzles. Flame is in both the primary and secondary stages. This mode of operation is

used for intermediate loads between two pre-selected combustion reference temperatures.

Secondary Fuel to the secondary nozzle only. Flame is in the secondary zone only. This mode is a transition state between lean-lean and premix modes. This mode is necessary to extinguish the flame in the primary zone, before fuel is reintroduced into what becomes the primary premixing zone.

Premix Fuel to both primary and secondary nozzles. Flame is in the secondary stage only. This mode of operation is achieved at and near the combustion reference temperature design point. Optimum emissions are generated in premix mode.

The load range associated with these modes varies with the degree of inlet guide vane modulation and, to a smaller extent, with the ambient temperature. At ISO ambient, the premix operating range is 50% to 100% load with IGV modulation down to 42°, and 75% to 100% load with IGV modulation down to 57°. The 42° IGV minimum requires an inlet bleed heat system.

If required, both the primary and secondary fuel nozzles can be dual-fuel nozzles, thus allowing automatic transfer from gas to oil throughout the load range. When burning either natural gas or distillate oil, the system can operate to full load in the lean-lean mode (Figure 6) and in the pre-mixed. Power augmentation with water is the most common reason.

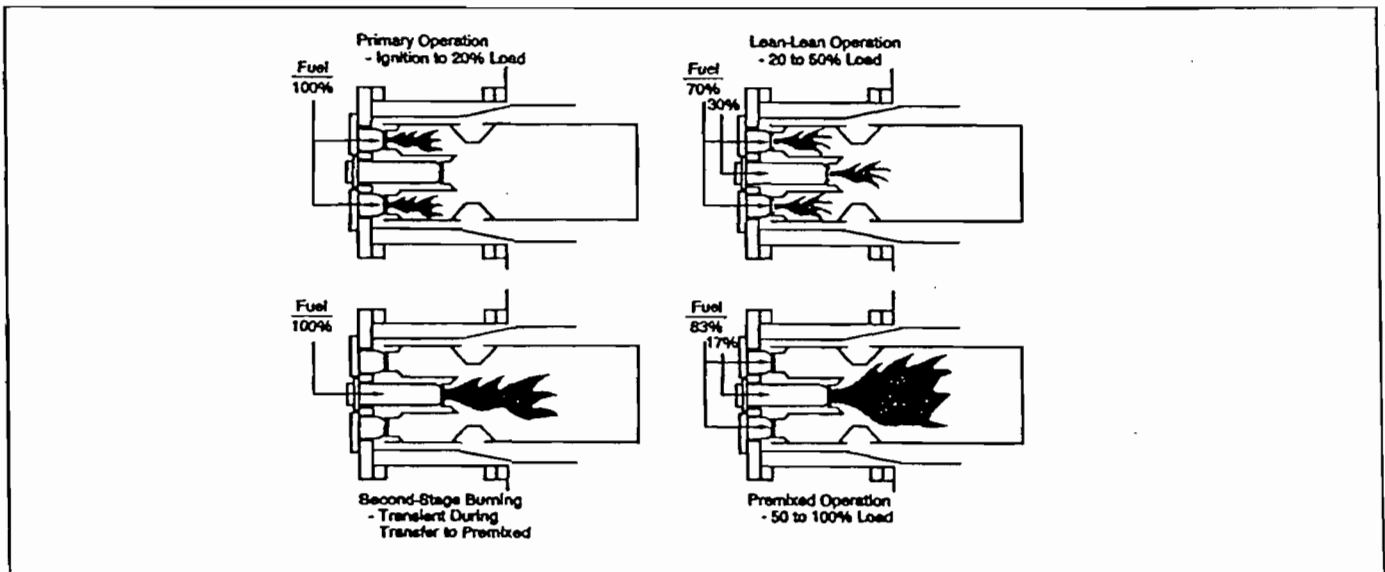

Figure 6. Fuel-staged Dry Low NO_x operating modes

The spark plug and flame detector arrangements in a DLN-I combustor are different from those used in a conventional combustor. Since

first stage must be re-ignited at high load in order to transfer from the premixed mode back to lean-lean operation, the spark plugs do not retract. One plug is mounted in a primary zone cup in each of two combustors. The system uses flame detectors to view the primary stage of selected chambers (similar to conventional systems), and secondary flame detectors that look through the centerbody and into the second stage.

The primary fuel injection system is used during ignition and part load operation. The system also injects most of the fuel during premixed operation and must be capable of stabilizing the flame. For this reason, the DLN-I primary fuel nozzle is similar to GE's MS7001EA multi-nozzle combustor with multiple swirl-stabilized fuel injectors. The GE DLN-I system uses five primary fuel nozzles for the MS6001B and smaller machines and six primary fuel nozzles for the larger machines. This design is capable of providing a well-stabilized diffusion flame that burns efficiently at ignition and during part load operation.

In addition, the multi-nozzle fuel injection system provides a satisfactory spatial distribution of fuel flow entering the first-stage mixer. The primary fuel-air mixing section is bound by the combustor first-stage wall, the cap/centerbody and the forward cone of the venturi. This volume serves as a combustion zone when the combustor operates in the primary and lean-lean modes. Since ignition occurs in this stage, cross-fire tubes are installed to propagate flame and to balance pressures between adjacent chambers. Film slots on the liner walls provide cooling, as they do in a standard combustor.

In order to achieve good emissions performance in premixed operation, the fuel-air equivalence ratio of the mixture exiting the first-stage mixer must be very lean. Efficient and stable burning in the second stage is achieved by providing continuous ignition sources at both the inner and outer surfaces of this flow. The three elements of this stage comprise a piloting flame, an associated aerodynamic device to force interaction between the pilot flame and the inner surface of the main stage flow, and an aerodynamic device to create a stable flame zone on the outer surface of the main stage flow exiting the first stage.

The piloting flame is generated by the secondary fuel nozzle, which premixes a portion of

the natural gas fuel and air (nominally, 17% at full-load operation) and injects the mixture through a swirler into a cup where it is burned. This flame is stabilized by burning an even smaller amount of fuel (less than 2% of the total fuel flow) as a diffusion flame in the cup. The secondary nozzle, which is mounted in the cap centerbody, is simple and highly effective for creating a stable flame.

A swirler mounted on the downstream end of the cap/centerbody surrounds the secondary nozzle. This creates a swirling flow that stirs the interface region between the piloting flame and the main-stage flow and ensures that the flame is continuously propagated from the pilot to the inner surface of the fuel-air mixture exiting the first stage. Operation on oil fuel is similar except that all of the secondary oil is burned in a diffusion flame in the current dry oil design.

The sudden expansion at the throat of the venturi creates a toroidal recirculation zone over the downstream conical surface of the venturi. This zone, which entrains a portion of the venturi cooling air, is a stable burning zone that acts as an ignition source for the main stage fuel-air mixture. The cone angle and axial location of the venturi cooling air dump have significant effects on the efficacy of this ignition source. Finally, the dilution zone (the region of the combustor immediately downstream from the flame zone in the secondary) provides a region for CO burnout and for shaping the gas temperature profile exiting the combustion system.

DLN-I Controls and Accessories

The gas turbine accessories and control systems are configured so that operation on a DLN-equipped turbine is essentially identical to that of a turbine equipped with a conventional combustor. This is accomplished by controlling the turbines in identical fashions, with the exhaust temperature, speed and compressor discharge pressure establishing the fuel flow and compressor inlet guide vane position.

A turbine with a conventional diffusion combustor that uses diluent injection for NO_x control will use an underlying algorithm to control steam or water injection. This algorithm will use top level control variables (exhaust temperature, speed, etc.) to establish a steam-to-fuel or water-to-fuel ratio to control NO_x .

In a similar fashion, the same variables are used to divide the total turbine fuel flow between the primary and secondary stages of a DLN combustor. The fuel division is accom-

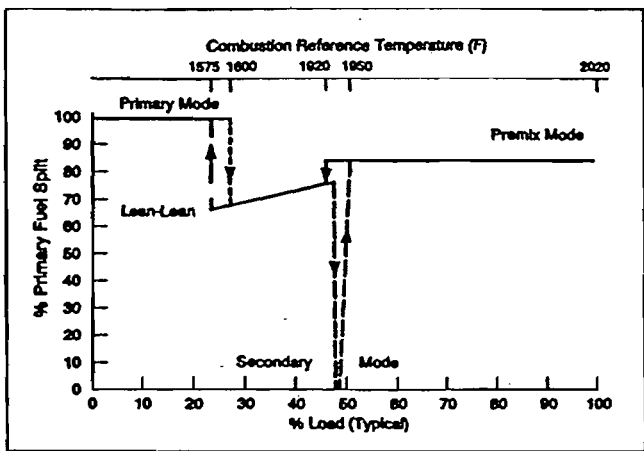

GT20327B

Figure 7. Typical Dry Low NO_x fuel gas split schedule

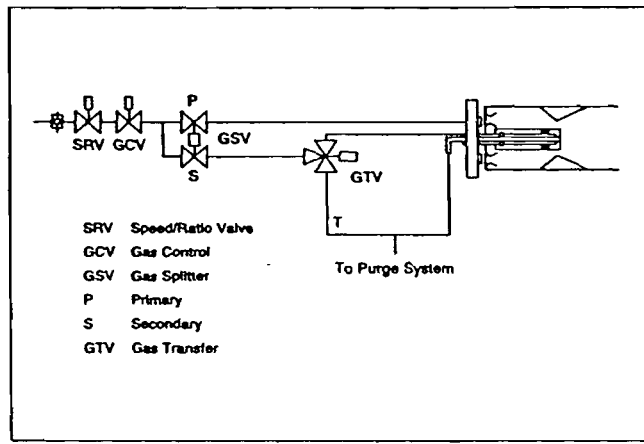

GT20339C

Figure 8. DLN-1 gas fuel system

plished by commanding a calibrated splitter valve to move to a set position based on the calculated combustion reference temperature (Figure 7). Figure 8 shows a schematic of the gas fuel system for a DLN-equipped turbine.

The only special control sequences required are concerned protection of the turbine during a generator breaker-open trip, or flashback, from the second stage to the first stage during premixed operation. When either the breaker opens at load or flashback is sensed by ultraviolet flame detectors looking into the first stage, the splitter valve is commanded to move to a pre-determined position. In the case of a flashback, the control system can execute an automatic sequence to return to premixed, full-load operation.

DLN-1 Emissions

The emissions performance of the GE DLN system can be illustrated as a function of load

for a given ambient temperature and turbine configuration. Figures 9 and 10 show the NO_x and CO emissions from typical MS7001EA and MS6001B DLN systems designed for 9 ppb NO_x and 25 ppm CO when operated on natural gas fuel. Note that in premixed operation, NO_x is generally highest at higher loads and CO only approaches 25 ppm at lower premixed loads.

Figures 11 and 12 show NO_x and CO emissions for the same systems operated on oil fuel with water injection for NO_x control, rather than premixed oil. These figures are for units equipped with inlet bleed heat and extended IGV modulation. NO_x and CO emissions from the DLN combustor at loads less than 20% of base load are similar to those from standard combustion systems. This result is expected because both systems are operating as diffusion flame combustors in this range. Between 20% and 50% load, the DLN system is operated in the lean-lean mode, and the flow split between the primary fuel nozzles and secondary nozzle is varied to give the decreasing NO_x characteristic shown.

From 50% to 100% load, the DLN system operates as a lean premixed combustor. As shown in

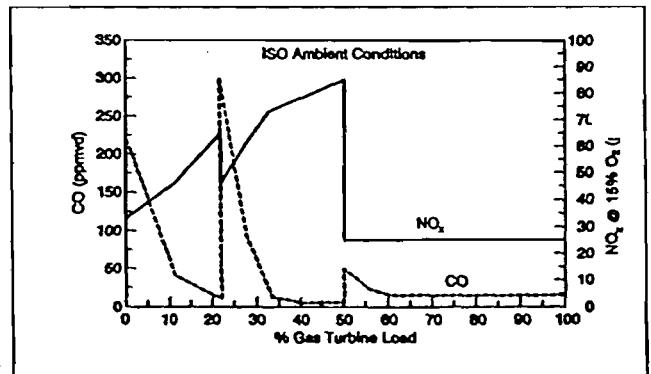

GT21768D

Figure 9. MS7001EA/MS9001E DLN-1 combustion system performance on natural gas fuel

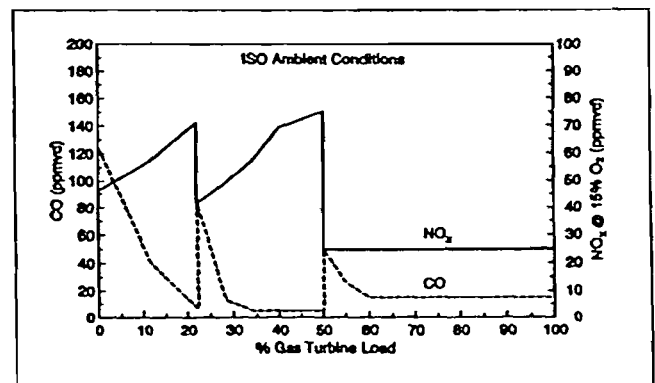

G7 9C

Figure 10. MS6001B DLN-1 emissions performance on natural gas fuel

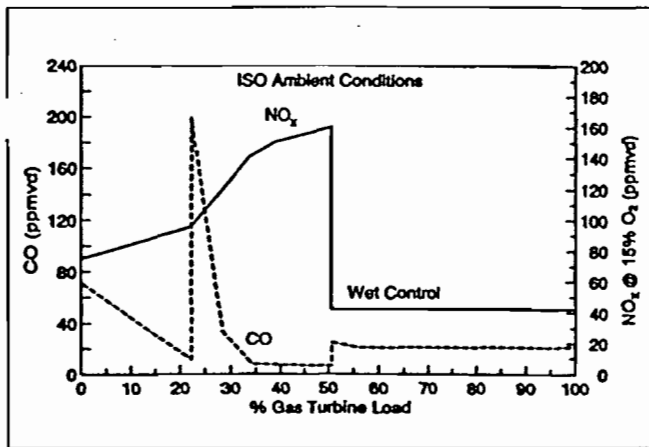

GT23207B

Figure 11. MS7001EA/MS9001E DLN-1 combustion system performance on distillate oil

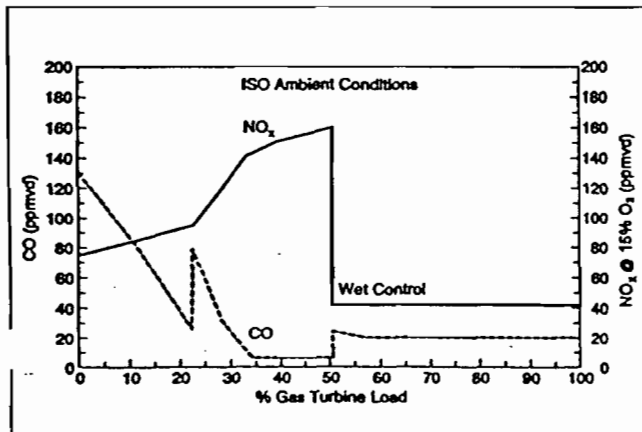

GT21766C

Figure 12. MS6001B DLN-1 emissions performance on distillate oil fuel

Figures 9 through 12, NO_x emissions are significantly reduced, while CO emissions are comparable to those from the standard system.

DLN-1 Experience

GE's first DLN-1 system was tested at Houston Lighting & Power in 1980 (Reference 7). A prototype DLN system using the combustor design discussed above was tested on an MS9001E at the Electricity Supply Board's (ESB) Northwall Station in Dublin, Ireland, between October 1989 and July 1990. A comprehensive engineering test of the prototype DLN combustor, controls and associated systems was conducted with NO_x levels of 32 ppmvd (at 15% O_2) obtained at base load. The results were incorporated into the design of prototype systems for the MS7001E and MS6001B.

The 7E DLN-1 prototype was tested at Anchorage Municipal Light and Power (AMLP)

in early 1991 and entered commercial service shortly afterward. Since then, development of advanced combustor configurations have been carried out at AMLP. These results have been incorporated into production hardware.

The MS6001B prototype system was first operated at Jersey Central Power & Light's Forked River Station in early 1991. A series of additional tests culminated in the demonstration of a 9 ppm combustor at Jersey Central in November 1993.

As of August 1996, 28 MS6001B machines are equipped with DLN-1 systems. In total, they have accumulated more than 370,000 hours of operation. There are, in addition, four MS7001E, eight MS7001B-E, 26 MS7001EA, 18 MS9001E, one MS5001P and three MS3002J DLN-1 machines that have collectively operated for more than 350,000 hours. Excellent emission results have been obtained in all cases, with single-digit NO_x and CO achieved on several MS7001EAs. Several MS7001E/EA machines have the capability to power augment with either massive water or steam injection.

Starting in early 1992, eight MS7001F machines equipped with GE DLN systems were placed in service at Korea Electric Power Company's Seoinchon site. These F technology machines have achieved better than 55% (gross) efficiency in combined-cycle operation, and the DLN systems are currently operating between 30 and 40 ppmvd NO_x on gas fuel (the guarantee level is 50 ppmvd). These units have operated for more than 150,000 hours. Four additional F technology DLN-1 systems have been commissioned at Scottish Hydro's Keadby site and at National Power's Little Barford site. These 9F machines have operated more than 20,000 hours at less than 60 ppm NO_x .

The combustion laboratory testing and field operation have shown that the DLN-1 system can achieve single digit NO_x and CO levels on E technology machines operating on gas fuel. Current DLN-1 development activity focuses on four goals:

- Application of single-digit technology to the MS6001B, MS7001EA and MS9001E
- Application of DLN-1 technology for retrofitting existing field machines (including MS3002s and MS5000s, some of which will require upgrade before DLN retrofit)
- Completing the development of steam and water power augmentation as needed by the market
- Completing the development of dry oil DLN-1 products.

DLN-2 SYSTEM

As F-technology gas turbines became available in the late 1980s, studies were conducted to establish what type of DLN combustor would be needed for these new higher firing temperature machines. Studies concluded that that air usage in the combustor (e.g., for cooling) other than for mixing with fuel would have to be strictly limited. A team of engineers from GE Power Generation, GE Corporate Research and Development and GE Aircraft Engine proposed a design that repackaged DLN-1 premixing technology but eliminated the venturi and centerbody assemblies that require cooling air.

The resulting combustor is called DLN-2, which is the standard system for the 6FA, 7FA, 9FA, 9EC, 7G, 7H, 9G and 9H machines. Fourteen combustors are installed in the 7FA and 9EC, 18 in the 9FA, and six in the 6FA. These combustors, for all but the 7FA, are not scaled, but are full-size 9FA combustors; the 7FA is slightly smaller.

DLN-2 Combustion System

The DLN-2 combustion system shown in Figure 13 is a single-stage dual-mode combustor that can operate on both gaseous and liquid fuel. On gas, the combustor operates in a diffusion mode at low loads (< 50% load), and a premixed mode at high loads (> 50% load). While the combustor can operate in the diffusion mode across the load range, diluent injection would be required for NO_x abatement. Oil operation on this combustor is in the diffusion mode across the entire load range, with diluent injection used for NO_x control.

Each DLN-2 combustor system has a single burning zone formed by the combustor liner and the face of the cap. In low emissions operation, 90% of the gas fuel is injected through radial gas injection spokes in the pre-mixer, and combustion air is mixed with the fuel in tubes surrounding each of the five fuel nozzles. The pre-mixer tubes are part of the cap assembly. The fuel and air are thoroughly mixed, flow out of the five tubes at high velocity and enter the burning zone where lean, low- NO_x combustion occurs. The vortex breakdown from the swirling flow exiting the premixers, along with the sudden expansion in the liner, are mechanisms for flame stabilization. The DLN-2 fuel nozzle/pre-mixer tube arrangement is similar in design and technology to the secondary nozzle/centerbody of a DLN-1. Five nozzle/pre-mixer tube assem-

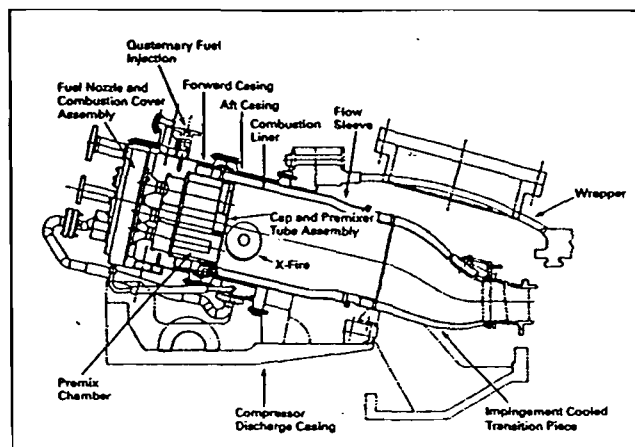

GT24549

Figure 13. DLN-2 combustion system

blies are located on the head end of the combustor. A quaternary fuel manifold is located on the circumference of the combustion casing to bring the remaining fuel flow to casing injection pegs located radially around the casing.

Figure 14 shows a cross-section of a DLN-2 fuel nozzle. As noted, the nozzle has passages for diffusion gas, premixed gas, oil and water. When mounted on the end cover, as shown in Figure 15, the diffusion passages of four of the fuel nozzles is fed from a common manifold, called the primary, that is built into the end cover. The premixed passage of the same fuel nozzle is fed from another internal manifold called the secondary. The premixed passages of the remaining nozzle are supplied by the tertiary fuel system; the diffusion passage of that nozzle is always purged with compressor discharge air and passes no fuel.

Figure 15 shows the fuel nozzles installed on the combustion chamber end cover and the

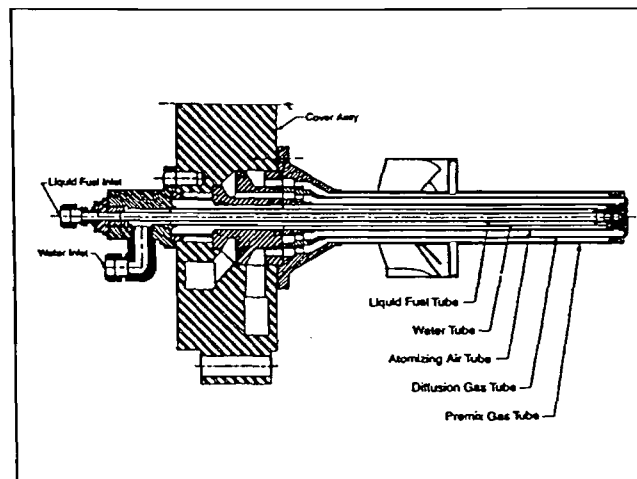

GT 79

Figure 14. Cross-section of a DLN-2 fuel nozzle

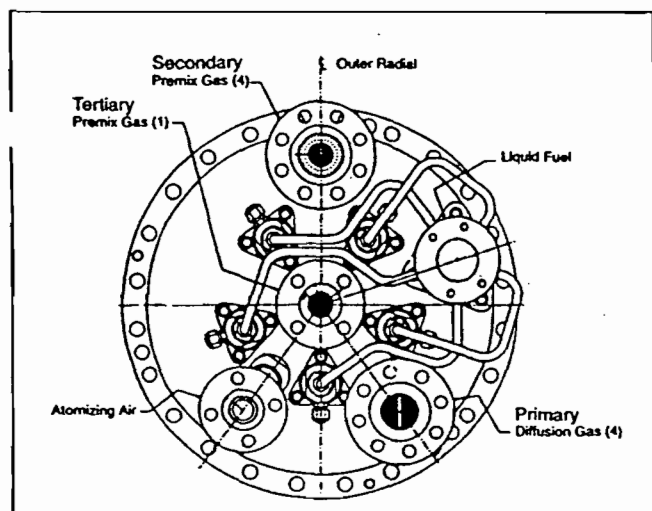

Figure 15. External view of DLN-2 fuel nozzles mounted

connections for the primary, secondary and tertiary fuel systems. DLN-2 fuel streams are:

- Primary fuel — fuel gas entering through the diffusion gas holes in the swirler assembly of each of the outboard four fuel nozzles
- Secondary fuel — premix fuel gas entering through the gas metering holes in the fuel gas injector spokes of each of the outboard four fuel nozzles
- Tertiary fuel — premix fuel gas delivered by the metering holes in the fuel gas injector spokes of the inboard fuel nozzle
- The quaternary system — injects a small amount of fuel into the airstream just upstream from the fuel nozzle swirlers

The DLN-2 combustion system can operate in several different modes.

Primary

Fuel only to the primary side of the four fuel nozzles; diffusion flame. Primary mode is used from ignition to 81% corrected speed.

Lean-Lean

Fuel to the primary (diffusion) fuel nozzles and single tertiary (premixing) fuel nozzle. This mode is used from 81% corrected speed to a preselected combustion reference temperature. The percentage of primary fuel flow is modulated throughout the range of operation as a function of combustion reference temperature. If necessary, lean-lean mode can be operated throughout the entire load range of the turbine. Selecting "lean-lean base on" locks out premix operation and enables the machine to be taken base load in lean-lean.

Premix Transfer

Transition state between lean-lean and premix modes. Throughout this mode, the primary and secondary gas control valves modulate to their final position for the next mode. The premix splitter valve is also modulated to hold a constant tertiary flow split.

Piloted Premix

Fuel is directed to the primary, secondary and tertiary fuel nozzles. This mode exists while operating with temperature control off as an intermediate mode between lean-lean and premix mode. This mode also exists as a default mode out of premix mode and, in the event that premix operating is not desired, piloted premix can be selected and operated to base load. Primary, secondary and tertiary fuel split are constant during this mode of operation.

Premix

Fuel is directed to the secondary, tertiary and quaternary fuel passages and premixed flame exists in the combustor. The minimum load for premixed operation is set by the combustion reference temperature and IGV position. It typically ranges from 50% with inlet bleed heat on to 65% with inlet bleed heat off. Mode transition from premix to piloted premix or piloted premix to premix, can occur whenever the combustion reference temperature is greater than 2200 F/1204 C. Optimum emissions are generated in premix mode.

Tertiary Full Speed No Load (FSNL)

Initiated upon a breaker open event from any load greater than 12.5%. Fuel is directed to the tertiary nozzle only and the unit operates in secondary FSNL mode for a minimum of 20 seconds, then transfers to lean-lean mode.

Figure 16 illustrates the fuel flow scheduling associated with DLN-2 operation. Fuel staging depends on combustion reference temperature and IGV temperature control operation mode.

DLN-2 Controls and Accessories

The DLN-2 control system regulates the fuel distribution to the primary, secondary, tertiary and quaternary fuel system. The fuel flow distribution to each combustion fuel system is a function of combustion reference temperature and IGV temperature control mode. Diffusion, piloted premix and premix flame are established by changing the distribution of fuel flow in the combustor. The gas fuel system (Figure 17) consists of the gas fuel stop/ratio valve, primary gas

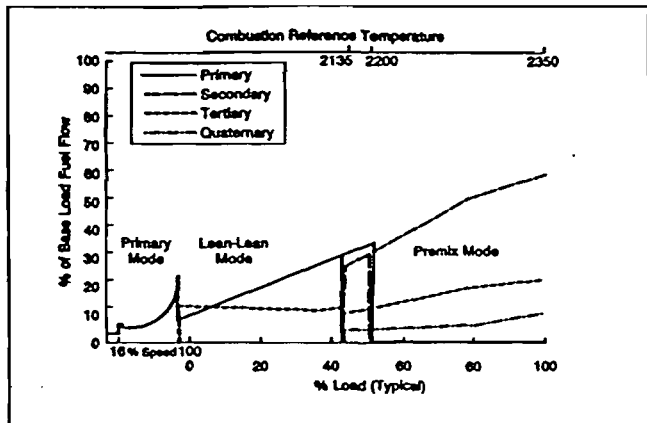

GT24671

Figure 16. Fuel flow scheduling associated with DLN-2 operation

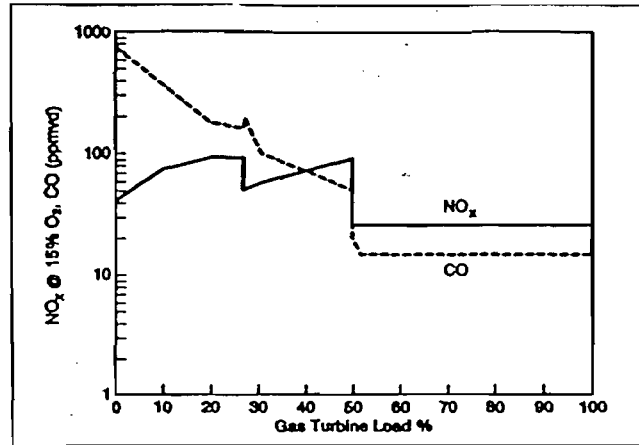

GT24554

Figure 18. Emissions performance for DLN-2-equipped 7FA/9FA for gas fuel

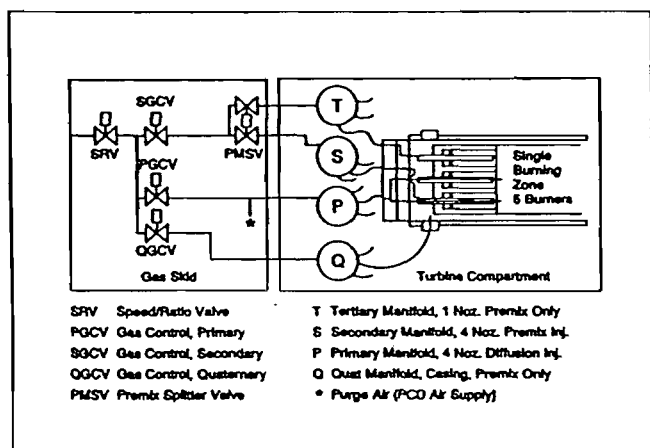

GT24553

Figure 17. DLN-2 gas fuel system

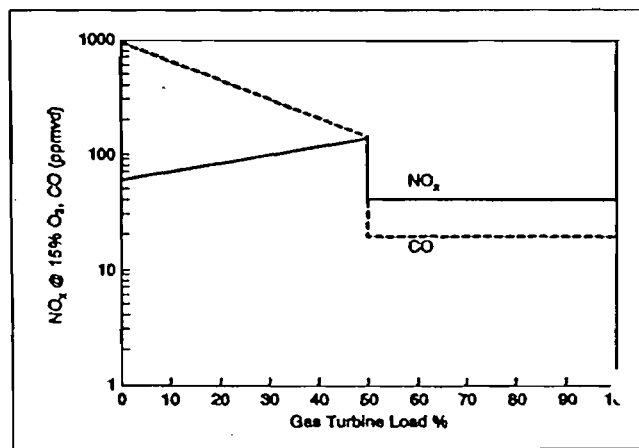

GT24555

Figure 19. Emissions performance for DLN-2-equipped 7FA/9FA for oil fuel with water injection

control valve, secondary gas control valve pre-mix splitter valve and quaternary gas control valve. The stop/ratio valve is designed to maintain a predetermined pressure at the control valve inlet.

The primary, secondary and quaternary gas control valves regulate the desired gas fuel flow delivered to the turbine in response to the fuel command from the SPEEDTRONIC™ controls.

The pre-mix splitter valve controls the fuel flow split between the secondary and tertiary fuel system.

DLN-2 Emissions Performance

Figures 18 and 19 show the emissions performance for a DLN-2 equipped 7FA/9FA for gas fuel and for oil fuel with water injection.

DLN-2 Experience

The first DLN-2 systems were placed in ser-

vice at Florida Power and Light's Martin Station with commissioning beginning in September 1993, and the first two (of four) 7FA units entering commercial service in February 1994. During commissioning, quaternary fuel was added and other combustor modifications were made to control dynamic pressure oscillations in the combustor.

As of August 1996, 23 DLN-2 7FA and 17 9FA units are in commercial service. They have accumulated more than 150,000 hours of operation. Of these units, 11 are dual-fuel units, and the remainder are gas-only.

CONCLUSION

GE's Dry Low NO_x Program continues to focus on the development of systems capable of the extremely low NO_x levels required to meet

today's regulations and to prepare for more stringent requirements in the future. New unit production needs and the requirements of existing machines, are being addressed. GE DLN systems are operating on more than 145 machines and have accumulated more than one million service hours. More than 200 DLN systems have been either put into service, shipped or placed on order. GE is the only manufacturer with F technology machines operating below 25 ppmvd.

APPENDIX

Gas Turbine Combustion Systems

A gas turbine combustor mixes large quantities of fuel and air and burns the resulting mixture. In concept the combustor is comprised of a fuel injector and a wall to contain the flame. There are three fundamental factors and practical concerns that complicate the design of the combustor: equivalence ratio, flame stability, and ability to operate from ignition through full load.

Equivalence ratio

A flame burns best when there is just enough fuel to react with the available oxygen. With this stoichiometric mixture (equivalence ratio of 1.0) the flame temperature is the highest and the chemical reactions are the fastest, compared to cases where there is either more oxygen ("fuel lean," < 1.0) or less oxygen ("fuel rich," > 1.0) for the amount of fuel present.

In a gas turbine, the maximum temperature of the hot gases exiting the combustor is limited by the tolerance of the turbine nozzles and buckets. This temperature corresponds to an equivalence ratio of 0.4 to 0.5 (40 to 50% of the stoichiometric fuel flow). In the combustors used on modern gas turbines, this fuel-air mixture would be too lean for stable and efficient burning. Therefore, only a portion of the compressor discharge air is introduced directly into the combustor reaction zone (flame zone) to be mixed with the fuel and burned. The balance of the airflow either quenches the flame prior to the combustor discharge entering the turbine or to cool the wall of the combustor.

Flame stability

Even with only part of the air being introduced into the reaction zone, flow velocities in the zone are higher than the turbulent flame

speed at which a flame propagates through the fuel-air mixture. Special mechanical or aerodynamic devices must be used to stabilize the flame by providing a low velocity region. Modern combustors employ a combination of swirlers and jets to achieve a good mix and to stabilize the flame.

Operational Stability

The combustor must be able to ignite and to support acceleration and operation of the gas turbine over the entire load range of the machine. For a single-shaft generator-drive machine, speed is constant under load and, therefore, so is the airflow for a fixed ambient temperature. There will be a five- or six-to-one turndown in fuel flow over the load range, and a combustor whose reaction zone equivalence ratio is optimized for full load operation will be very lean at the lower loads. Nevertheless, the flame must be stable and the combustion process must be efficient at all loads.

GE uses multiple-combustion chamber assemblies in its heavy-duty gas turbines to achieve reliable and efficient turbine operation. As shown in Figure A-1, each combustion chamber assembly comprises a cylindrical combustor, a fuel injection system and a transition piece that guides the flow of the hot gas from the combustor to the inlet of the turbine. Figure A-2 illustrates the multiple-combustor concept.

There are several reasons for using the multiple-chamber arrangement instead of large silo-type combustors:

- The configuration permits the entire turbine to be factory assembled, tested and shipped without interim disassembly
- The turbine inlet temperature can be better controlled, thus providing for longer turbine life with reduced turbine cooling air requirements
- Smaller parts can be handled more easily during routine maintenance
- Smaller transition pieces are less susceptible to damage from dynamic forces generated in the combustor; furthermore, the shorter combustion system length ensures that acoustic natural frequencies are higher and less likely to couple with the pressure oscillations in the flame
- Smaller combustors generate less NO_x because of much better mixing and shorter residence time
- As turbine inlet temperatures have increased to improve efficiency, the size of the combustors has decreased to minimize cooling

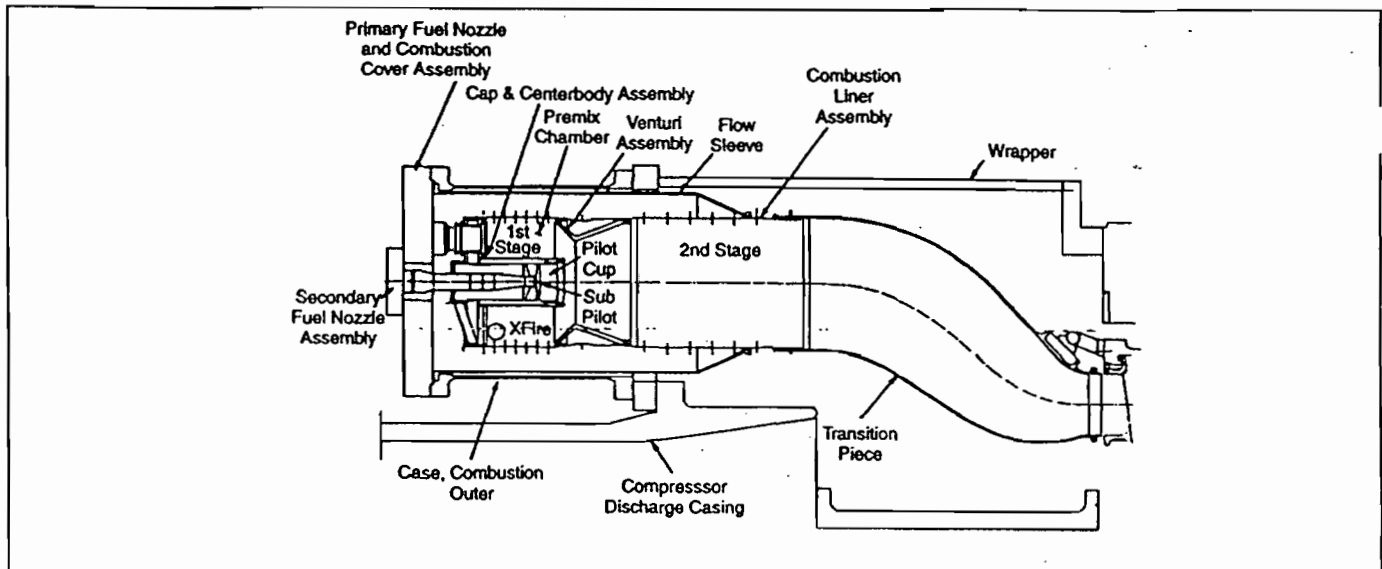

GT21897A

Figure A1. MS7001EA Dry Low NO_x combustion chamber

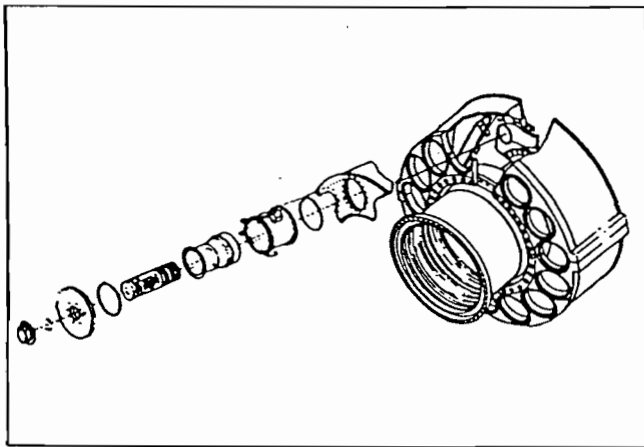

GT18556

Figure A2. Exploded view of combustion chamber

requirements, as in aircraft gas turbine combustors

- Small can-type combustors can be completely developed in the laboratory through a combination of both atmospheric and full-pressure, full-flow tests. Therefore, there is a higher degree of confidence that a combustor will perform as designed across all load ranges before it is installed and tested in a machine.

Gas Turbine Emissions

The significant products of combustion in gas turbine emissions are:

- Oxides of nitrogen (NO and NO_2 , collectively called NO_x)
- Carbon monoxide (CO)

- Unburned hydrocarbons or UHCs (usually expressed as equivalent methane (CH_4) particles and arise from incomplete combustion)
- Oxides of sulfur (SO_2 and SO_3) particulates.

Unburned hydrocarbons include both volatile organic compounds (VOCs), which contribute to the formation of atmospheric ozone, and compounds, such as methane, that do not.

There are two sources of NO_x emissions in the exhaust of a gas turbine. Most of the NO_x is generated by the fixation of atmospheric nitrogen in the flame, which is called thermal NO_x . Nitrogen oxides are also generated by the conversion of a fraction of any nitrogen chemically bound in the fuel (called fuel-bound nitrogen or FBN). Lower-quality distillates and low-Btu coal gases from gasifiers with hot gas cleanup carry various amounts of fuel-bound nitrogen that must be taken into account when emissions calculations are made. The methods described below to control thermal NO_x emissions are ineffective in controlling the conversion of FBN to NO_x .

Thermal NO_x is generated by a chemical reaction sequence called the Zeldovich Mechanism (Reference 6). This set of well-verified chemical reactions postulates that the rate of generation of thermal NO_x is an exponential function of the temperature of the flame. The amount of NO_x generated is a function of the flame temperature and of the time the hot mixture is at flame temperature. This turns out

to be a linear function of time. Thus, temperature and residence time determine thermal NO_x emissions levels and are the principal variables that a gas turbine designer can adjust to control emission levels.

For a given fuel, since the flame temperature is a unique function of the equivalence ratio, the rate of NO_x generation can be cast as a function of the equivalence ratio. Figure A-3, shows that the highest rate of NO_x production occurs at an equivalence ratio of 1.0, when the temperature is equal to the stoichiometric, adiabatic flame temperature.

To the left of the maximum temperature point (Figure A-3), more oxygen is available (the equivalence ratio is less than 1.0) and the resulting flame temperature is lower. This is a fuel-lean operation. Since the rate of NO_x formation is a function of temperature and time, it follows that some difference in NO_x emissions can be expected when different fuels are burned in a given combustion system. Since distillate oil and natural gas have approximately a 100 F/38 C flame temperature difference, a significant difference in NO_x emissions can be expected if reaction zone equivalence ratio, water injection rate, etc. are equal.

As shown in Figure A-3, the rate of NO_x production dramatically decreases as flame temperature decreases (i.e., the flame becomes fuel lean). This is because of the exponential effect of temperature in the Zeldovich Mechanism and is the reason why diluent injection (usually water or steam) into a gas turbine combustor flame zone reduces NO_x emissions. For the same reason, very lean dry combustors can be used to control emissions. This is desirable for reaching the lower NO_x levels now required in many applications.

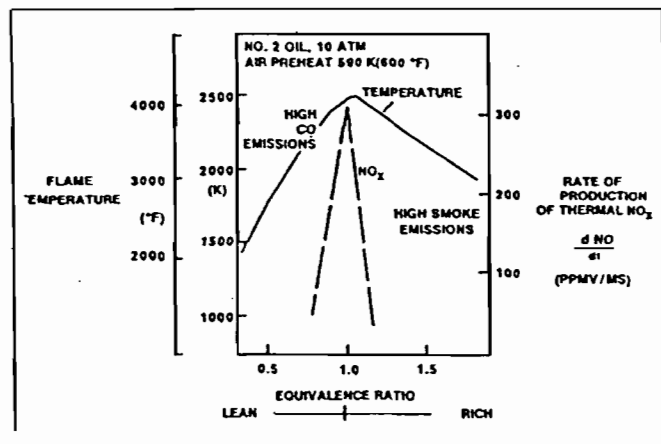
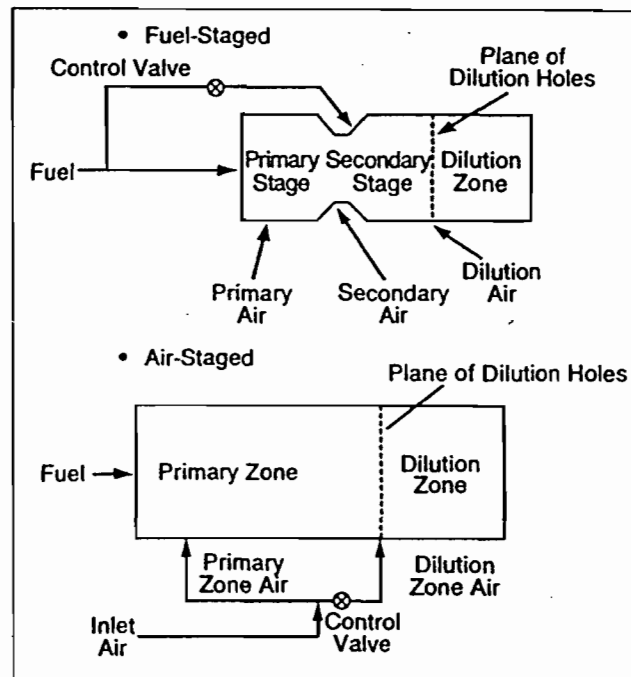

Figure A3. Rate of thermal NO_x production



GT17208-1A

Figure A4. Staged combustors

There are two design challenges associated with very lean combustors. First, care must be taken to ensure that the flame is stable at the design operating point. Secondly, a turndown capability is necessary since a gas turbine must ignite, accelerate, and operate over the load range. At lower loads, as fuel flow to the combustors decreases, the flame will be very lean and will not burn well, or it can become unstable and blow out.

In response to these challenges, combustion system designers use staged combustors so a portion of the flame zone air can mix with the fuel at lower loads or during startup. The two types of staged combustors are fuel-staged and air-staged (Figure A-4). In its simplest and most common configuration, a fuel-staged combustor has two flame zones; each receives a constant fraction of the combustor airflow. Fuel flow is divided between the two zones so that at each machine operating condition, the amount of fuel fed to a stage matches the amount of air available.

An air-staged combustor uses a mechanism for diverting a fraction of the airflow from the flame zone to the dilution zone at low load to increase turndown. These methods can be combined.

Emissions Control Methods

There are three principal methods for controlling gas turbine emissions:

- Injection of a diluent such as water or steam into the burning zone of a conventional (diffusion flame) combustor
- Catalytic clean-up of NO_x and CO from the gas turbine exhaust (usually used in conjunction with the other two methods)
- Design of the combustor to limit the formation of pollutants in the burning zone by utilizing "lean-premixed" combustion technology.

The last method includes both DLN combustors and catalytic combustors. GE has considerable experience with each of these three methods.

Since September 1979, when regulations required that NO_x emissions be limited to 75 ppmvd (parts per million by volume, dry), more than 300 GE heavy-duty gas turbines have accumulated more than 2.5 million operating hours using either steam or water-injection to meet or exceed these required NO_x emissions levels. The amount of water required to accomplish this is approximately one-half of the fuel flow. However, there is a 1.8% heat-rate penalty associated with using water to control NO_x emissions for oil-fired simple-cycle gas turbines. Output, increases by approximately 3%, making water (or steam) injection for power augmentation economically attractive in some circumstances (such as peaking applications).

Single-nozzle combustors that use water or steam injection are limited in their ability to reduce NO_x levels below 42 ppmvd on gas fuel and 65 ppmvd on oil fuel. GE developed multi-nozzle quiet combustors (MNQC) for the MS7001EA and MS7001FA capable of achieving 25 ppmvd on gas fuel and 42 ppmvd on oil, using either water or steam injection. Since October 1987, more than 26 MNQC-equipped MS7001s that use water or steam injection have been placed in service. One unit that uses steam injection has operated nearly 50,000 hours at 25 ppmvd NO_x (at 15% O₂).

Frequent combustion inspections and decreased hardware life are undesirable side effects that can result from the use of diluent injection to reduce NO_x emissions from combustion turbines. For applications that require NO_x emissions below 42 ppmvd (or 25 ppmvd in the case of the MS7001EA or MS7001FA MNQC), or to avoid the significant cycle efficiency penalties incurred when water or steam injection is used for NO_x control, one of the other two principal methods of NO_x control mentioned above must be used.

Selective catalytic reduction (SCR) converts NO and NO₂ in the gas turbine exhaust stream to molecular nitrogen and oxygen by reacting the NO_x with ammonia in the presence of a catalyst. Conventional SCR technology requires that the temperature of the exhaust stream remain in a narrow range (550 F to 750 F or 288 C to 399 C) and is restricted to applications with a heat recovery system installed in the exhaust. The SCR is installed at a location in the boiler where the exhaust gas temperature has decreased to the above temperature range. New high-temperature SCR technology is being developed that may allow SCRs to be used for applications without heat recovery boilers.

For an MS7001EA gas turbine, an SCR designed to remove 90% of the NO_x from the gas turbine exhaust stream has a volume of approximately 175 cubic meters and weighs 111 tons. It is comprised of segments stacked in the exhaust duct. Each segment has a honeycomb pattern with passages that are aligned in the direction of the exhaust gas flow. A catalyst, such as vanadium pentoxide, is deposited on the surface of the honeycomb.

SCR systems are sensitive to fuels containing more than 1,000 ppm of sulfur (light distillate oils may have up to 0.8% sulfur). There are two reasons for this sensitivity: first, sulfur poisons the catalyst being used in SCRs.

Secondly, the ammonia will react with sulfur in the presence of the catalyst to form ammonium bisulfate, which is extremely corrosive, particularly near the discharge of a heat recovery boiler. Special catalyst materials that are less sensitive to sulfur have been identified, and there are some theories as to how to inhibit the formation of ammonium bisulfate. This, however, remains an open issue with SCRs.

More than 100 GE units have accumulated more than 100,000 operating hours with SCRs installed. Twenty of the units are in Japan; others are located in California, New Jersey, New York and several other eastern U.S. states. Units operating with SCRs include MS9000s, MS7000s, MS6000s, LM2500s and LM5000s.

Lean premixed combustion is the basis for achieving low emissions from Dry Low NO_x and catalytic combustors. GE has participated in the development of catalytic combustors for many years. These systems use a catalytic reactor bed mounted within the combustor to burn a very lean fuel-air mixture. They have the potential to achieve extremely low emissions levels without resorting to exhaust gas cleanup. Technical ch...

lenges in the combustor and in the catalyst and reactor bed materials must be overcome in order to develop an operational catalytic combustor. GE has development programs in place with both ceramic and catalyst manufacturers to address these challenges. GE does not believe commercial systems employing this technology will be available in the near term.

REFERENCES

1. Washam, R. M., "Dry Low NO_x Combustion System for Utility Gas Turbine," ASME Paper 83-JPGC-GT-13, Sept. 1983.
2. Davis, L. B. and Washam, R. M., "Development of a Dry Low NO_x Combustor," ASME Paper No. 89-GT-255, June 1989.
3. Dibelius, N.R., Hilt, M.B., and Johnson, R.H., "Reduction of Nitrogen Oxides from Gas Turbines by Steam Injection," ASME Paper No. 71-GT-58, Dec. 1970.
4. Miller, H. E., "Development of the Quiet Combustor and Other Design Changes to Benefit Air Quality," American Cogeneration Association, San Francisco, March 1988.
5. Cutrone, M. B., Hilt, M. B., Goyal, A., Ekstedt, E. E., and Notardonato, J., "Evaluation of Advanced Combustor for Dry NO_x Suppression with Nitrogen Bearing Fuels in Utility and Industrial Gas Turbines," ASME Paper 81-GT-125, March 1981.
6. Zeldovich, J., "The Oxidation of Nitrogen in Combustion and Explosions," Acta Physicochimica USSR, Vol. 21, No. 4, 1946, pp 577-628.
7. Washam, R. M., "Dry Low NO_x Combustion System for Utility Gas Turbine," ASME Paper 83-JPGC-GT-13, Sept. 1983.
8. Davis, L. B., and Washam, R. M., "Development of a Dry Low NO_x Combustor," ASME Paper No. 89-GT-255, June 1989.

ATTACHMENT PSNCT5A-Dstack
DESCRIPTION OF STACK SAMPLING FACILITIES

ATTACHMENT PSNCT5A-Dstack

DESCRIPTION OF STACK SAMPLING FACILITIES

SANFORD POWER PLANT
UNIT SNCT5A
ORIS CODE: 000620

SCHEMATIC DIAGRAM/CEMS SAMPLE LOCATION

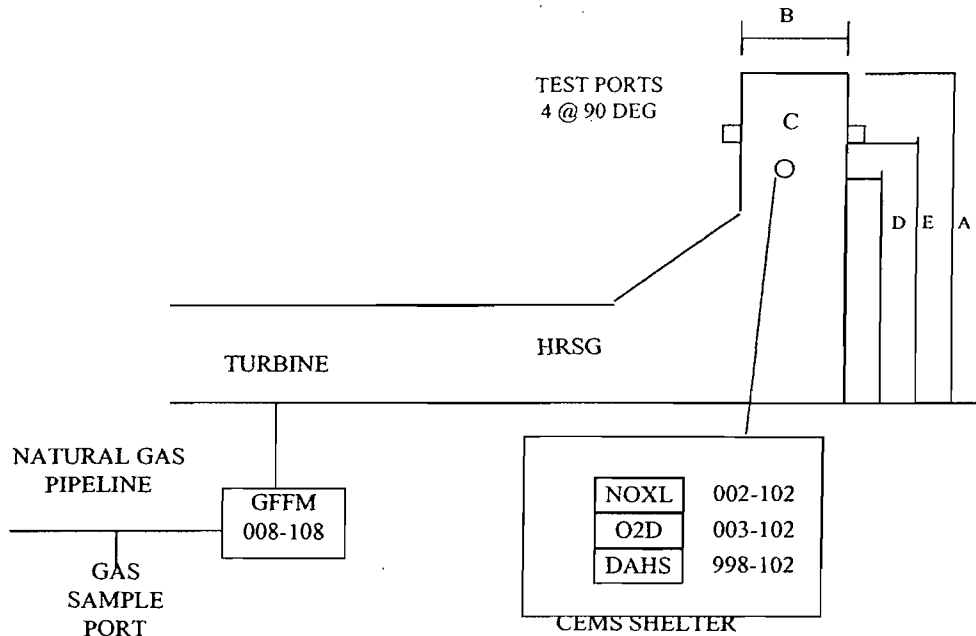

A - STACK HEIGHT ABOVE GRADE - 124 FEET, 8 INCHES

B - STACK INSIDE DIAMETER AT TEST PORT - 19 FEET

C - INSIDE CROSS-SECTIONAL AREA - 283.5 SQ FT

D - CEMS SAMPLE PROBE ELEVATION

1. ABOVE GRADE - 111 FEET, 8 INCHES

2. ABOVE LAST DISTURBANCE (HRSG EXIT)

FEET - 36 FEET, 8 INCHES

STACK DIAMETER - 1.9

3. PRIOR TO STACK EXIT

FEET - 13 FEET

STACK DIAMETERS - 0.7

E - EPA TEST PORT ELEVATION - 1 FOOT ABOVE CEM PROBE

STACK BASE ELEVATION ABOVE MEAN SEA LEVEL - 102 FEET, 6 INCHES

ATTACHMENT PSNCT5A-5D_6
PROCEDURES FOR STARTUP/SHUTDOWN

ATTACHMENT PSNCT5A-5D_6**CONTROLLING EXCESS EMISSIONS - OPERATING PROCEDURE****PERMIT LIMITS**

This instruction is to define the emission limits, which will govern the Sanford Unit 5 Combustion Turbines. These limits are naturally of vital importance in our Plant operations, and every effort shall be made to operate in compliance,. Each operator should be knowledgeable of these limitations.

Each CT must be operated within the emission limits as defined in the plant air-operating permit. The limits for each CT is as follows:

- NO_x shall not exceed 9 ppm as measured with the CEMS and corrected to 15% O₂. (30-day rolling average) when firing gas; 42 ppm corrected to 15% O₂ when firing oil (24-hour block average).
- CO shall not exceed 12 ppm (20 ppmvd) as measured during stack testing when firing gas.
- OPACITY shall not exceed 10% when firing gas and 20% when firing oil.

EXCESS EMISSIONS

- Excess emissions resulting from startup, shutdown, or malfunction of the *combustion turbines and heat recovery steam generators* shall be permitted provided that best operational practices are adhered to and the duration of excess emissions shall be minimized. Excess emissions occurrences shall in no case exceed two hours in any 24-hour period except during "cold start-up" to or shutdowns from combined cycle operation. During cold start-up to combined cycle operation, up to four hours of excess emissions are allowed. During shutdowns from combined cycle operation, up to three hours of excess emissions are allowed. Cold start-up is defined as a startup to combined cycle operation when the heat recovery steam generator high-pressure drum is below 450 psig for at least one hour.
- Excess emissions from the CTs resulting from startup of the *steam turbines system* shall be permitted provided that best operational practices are adhered to and the duration of excess emissions shall be minimized. Excess emissions occurrences shall in no case exceed 12 hours per cold startup of the steam turbine system.

EXCESS EMISSIONS REPORT

Excess emissions entirely or in part by poor maintenance, poor operation, or any other equipment or process failure that may reasonably be prevented during start-up, shut down or malfunction shall be prohibited.

If excess emissions occur for more than two hours due to a malfunction, the DEP Central District office shall be notified within 1 working day. They shall be advised of the nature, extent, and duration of the excess emissions, the cause of the emissions, and the action taken to correct the problem.

BEST OPERATIONAL PRACTICES

Best operating practices must always prevail during any period of operation. Best operating practices include any action taken for a given condition which will eliminate/minimize the duration of excess emissions; (i.e., reducing load, removal from load control, lowering load rate, or pressure rate changes).

Emergency situations, equipment failures, and any non-standard occurrence have always called for prompt operator action for a number of reasons. These regulations merely add one more quantitative reason for prompt actions. Dropping load, even removing the unit from the line may be necessary to meet the permit limits. As with all operating situations, good judgment regarding equipment and personnel safety, system conditions, and the like is imperative.

ATTACHMENT PSNCT5A-5D_12
ALTERNATIVE METHODS OF OPERATION

ATTACHMENT PSNCT5A-5D_12**ALTERNATIVE METHODS OF OPERATION**

CT5A through CT5D can be operated with natural gas or distillate oil. Operation of Unit 5 (CT 5A-CT 5D) is as a combined cycle unit with no simple cycle bypass stack. The CTs can be operated by by-passing steam from the steam turbine to the condenser.

ATTACHMENT PSNCT5A-5D_13
LIST OF APPLICABLE REGULATIONS

ATTACHMENT PSNCT5A-5D_13

APPLICABLE REQUIREMENTS LISTING

EMISSION UNIT ID: Combustion Turbines 5A – 5D

FDEP Rules:

Air Pollution Control-General Provisions:

62-204.800(7)(b)37. (State Only)	NSPS Subpart GG
62-204.800(7)(c) (State Only)	NSPS authority
62-204.800(7)(d)(State Only)	NSPS General Provisions
62-204.800(12) (State Only)	Acid Rain Program
62-204.800(13) (State Only)	Allowances
62-204.800(14) (State Only)	Acid Rain Program Monitoring
62-204.800(16) (State Only)	Excess Emissions (Potentially applicable over term of permit)

Stationary Sources-General:

62-210.650	Circumvention; EUs with control device
62-210.700(1)	Excess Emissions;
62-210.700(4)	Excess Emissions; poor maintenance
62-210.700(6)	Excess Emissions; notification

Acid Rain:

62-214.300	All Acid Rain Units (Applicability)
62-214.320	All Acid Rain Units (Application Shield)
62-214.330(1)(a)	Compliance Options (if 214.430)
62-214.340	Exemptions (retired units)
62-214.350(2);(3);(5);(6)	All Acid Rain Units (Certification)
62-214.370	All Acid Rain Units (Revisions; correction; potentially applicable if a need arises)
62-214.430	All Acid Rain Units (Compliance Options-if required)

Stationary Sources-Emission Standards:

62-296.320(4)(b)(State Only)	CTs/Diesel Units
------------------------------	------------------

Stationary Sources-Emission Monitoring (where stack test is required):

62-297.310(1)	All Units (Test Runs-Mass Emission)
62-297.310(2)	All Units (Operating Rate)
62-297.310(3)	All Units (Calculation of Emission)
62-297.310(4)	All Units (Applicable Test Procedures)
62-297.310(5)	All Units (Determination of Process Variables)
62-297.310(6)(a)	All Units (Permanent Test Facilities-general)
62-297.310(6)(c)	All Units (Sampling Ports)
62-297.310(6)(d)	All Units (Work Platforms)
62-297.310(6)(e)	All Units (Access)
62-297.310(6)(f)	All Units (Electrical Power)
62-297.310(6)(g)	All Units (Equipment Support)
62-297.310(7)(a)1.	Applies mainly to CTs/Diesels
62-297.310(7)(a)3.	Permit Renewal Test Required
62-297.310(7)(a)4.	Annual Test

62-297.310(7)(a)5.	PM exemption if <400 hrs/yr
62-297.310(7)(a)8.	VE Compliance Test if > 400 hrs/yr
62-297.310(7)(a)9.	FDEP Notification - 15 days
62-297.310(7)(c)	Waiver of Compliance Tests (Fuel Sampling)
62-297.310(8)	Test Reports

Federal Rules:

NSPS Subpart GG:

40 CFR 60.332(a)(1)	NO _x for Electric Utility CTs
40 CFR 60.332(a)(3)	NO _x for Electric Utility CTs
40 CFR 60.333	SO ₂ limits
40 CFR 60.334	Monitoring of Operations (Custom Monitoring for Gas)
40 CFR 60.335	Test Methods

NSPS General Requirements:

40 CFR 60.7(a)(1)	Notification of Construction
40 CFR 60.7(a)(3)	Notification of Actual Start-Up
40 CFR 60.7(a)(4) ✓	Notification and Recordkeeping (Physical/Operational Cycle)
40 CFR 60.7(a)(5)	Notification of CEM Demonstration
40 CFR 60.7(b) ✓	Recordkeeping (startup/shutdown/malfunction)
40 CFR 60.7(c) ✓	Notification and Recordkeeping (startup/shutdown/malfunction)
40 CFR 60.7(d) ✓	Notification and Recordkeeping (startup/shutdown/malfunction)
40 CFR 60.7(f)	Recordkeeping (maintain records-2 yrs)
40 CFR 60.8(a)	Performance Test Requirements
40 CFR 60.8(b)	Performance Test Requirements
40 CFR 60.8(c) ✓	Performance Tests (representative conditions)
40 CFR 60.8(d)	Performance Test Notification
40 CFR 60.8(e) ✓	Provide Stack Sampling Facilities
40 CFR 60.8(f)	Test Runs
40 CFR 60.11(a)	Compliance (ref. S. 60.8 or Subpart; other than opacity)
40 CFR 60.11(b) ✓	Compliance (opacity determined EPA Method 9)
40 CFR 60.11(c) ✓	Compliance (opacity; excludes startup/shutdown/malfunction)
40 CFR 60.11(d) ✓	Compliance (maintain air pollution control equip.)
40 CFR 60.11(e)(2).	Compliance (opacity; ref. S. 60.8)
40 CFR 60.12 ✓	Circumvention
40 CFR 60.13(a) ✓ (c) ✓	Monitoring (Appendix B; Appendix F)
40 CFR 60.13(d)(1) ✓	Monitoring (CEMS; span, drift, etc.)
40 CFR 60.13(e) ✓	Monitoring (frequency of operation)
40 CFR 60.13(f) ✓	Monitoring (frequency of operation)

Acid Rain-Permits:

40 CFR 72.9(a)	Permit Requirements
40 CFR 72.9(b)	Monitoring Requirements
40 CFR 72.9(c)(1)	SO ₂ Allowances-hold allowances
40 CFR 72.9(c)(2)	SO ₂ Allowances-violation
40 CFR 72.9(c)(3)(iv)	SO ₂ Allowances-Phase II Units
40 CFR 72.9(c)(4)	SO ₂ Allowances-allowances held in ATS
40 CFR 72.9(c)(5)	SO ₂ Allowances-no deduction for 72.9(c)(1)(i)
40 CFR 72.9(e)	Excess Emission Requirements
40 CFR 72.9(f)	Recordkeeping and Reporting

40 CFR 72.9(g)	Liability
40 CFR 72.20(a)	Designated Representative; required
40 CFR 72.20(b)	Designated Representative; legally binding
40 CFR 72.20(c)	Designated Representative; certification requirements
40 CFR 72.21	Submissions
40 CFR 72.22	Alternate Designated Representative
40 CFR 72.23	Changing representatives; owners
40 CFR 72.24	Certificate of representation
40 CFR 72.30(a)	Requirements to Apply
40 CFR 72.30(b)(2)	Requirements to Apply (Phase II-Complete)
40 CFR 72.30(c)	Requirements to Apply (reapply before expiration)
40 CFR 72.30(d)	Requirements to Apply (submittal requirements)
40 CFR 72.31	Information Requirements; Acid Rain Applications
40 CFR 72.32	Permit Application Shield
40 CFR 72.33(b)	Dispatch System ID; unit/system ID
40 CFR 72.33(c)	Dispatch System ID; ID requirements
40 CFR 72.33(d)	Dispatch System ID; ID change
40 CFR 72.40(a)	General; compliance plan
40 CFR 72.40(b)	General; multi-unit compliance options
40 CFR 72.40(d)	General; termination of compliance options
40 CFR 72.51	Permit Shield
40 CFR 72.90	Annual Compliance Certification
Allowances:	
40 CFR 73.33(a),(c)	Authorized account representative
40 CFR 73.35(c)(1)	Compliance: ID of allowances by serial number
Monitoring Part 75:	
40 CFR 75.4	Compliance Dates;
40 CFR 75.5	Prohibitions
40 CFR 75.10(a)(1)	Primary Measurement; SO ₂ ;
40 CFR 75.10(a)(2)	Primary Measurement; NO _x ;
40 CFR 75.10(a)(3)(iii)	Primary Measurement; CO ₂ ; O ₂ monitor
40 CFR 75.10(b)	Primary Measurement; Performance Requirements
40 CFR 75.10(c)	Primary Measurement; Heat Input; Appendix F
40 CFR 75.10(f)	Primary Measurement; Minimum Measurement
40 CFR 75.10(g)	Primary Measurement; Minimum Recording
40 CFR 75.11(d)	SO ₂ Monitoring; Gas- and Oil-fired units
40 CFR 75.11(e)	SO ₂ Monitoring; Gaseous firing
40 CFR 75.12(a)	NO _x Monitoring; Coal; Non-peaking oil/gas units
40 CFR 75.12(c)	NO _x Monitoring; Determination of NO _x emission rate; Appendix F
40 CFR 75.13(b)	CO ₂ Monitoring; Appendix G
40 CFR 75.13(c)	CO ₂ Monitoring; Appendix F
40 CFR 75.14(c)	Opacity Monitoring; Gas units; exemption
40 CFR 75.20(a)	Initial Certification Approval Process; Loss of Certification
40 CFR 75.20(b)	Recertification Procedures (if recertification necessary)
40 CFR 75.20(c)	Certification Procedures (if recertification necessary)
40 CFR 75.21(a)	QA/QC; CEMS; Appendix B (Suspended 7/17/95-12/31/96)
40 CFR 75.21(c)	QA/QC; Calibration Gases
40 CFR 75.21(d)	QA/QC; Notification of RATA

40 CFR 75.21(e)	QA/QC; Audits
40 CFR 75.22	Reference Methods
40 CFR 75.24	Out-of-Control Periods; CEMS
40 CFR 75.30(a)(3)	General Missing Data Procedures; NO _x
40 CFR 75.30(a)(4)	General Missing Data Procedures; CO ₂
40 CFR 75.30(d)	General Missing Data Procedures; SO ₂
40 CFR 75.31	Initial Missing Data Procedures (new/re-certified CMS)
40 CFR 75.32	Monitoring Data Availability for Missing Data
40 CFR 75.33	Standard Missing Data Procedures
40 CFR 75.36	Missing Data for Heat Input
40 CFR 75.53	Monitoring Plan; revisions
40 CFR 75.57(a)	Recordkeeping Requirements for Affected Sources
40 CFR 75.57(b)	Operating Parameter Record Provisions
40 CFR 75.57(d)	NO _x Emission Record Provisions
40 CFR 75.57(e)	CO ₂ Emission Record Provisions
40 CFR 75.57(h)	Missing Data Records
40 CFR 75.58(c)	Specific SO ₂ Emission Record Provisions
40 CFR 75.58(e)	Specific SO ₂ Emission Record Provisions
40 CFR 75.59	Certification; QA/QC Provisions
40 CFR 75.60	Reporting Requirements-General
40 CFR 75.61	Reporting Requirements-Notification cert/recertification
40 CFR 75.62	Reporting Requirements-Monitoring Plan
40 CFR 75.63	Reporting Requirements-Certification/Recertification
40 CFR 75.64(a)	Reporting Requirements-Quarterly reports; submission
40 CFR 75.64(b)	Reporting Requirements-Quarterly reports; DR statement
40 CFR 75.64(c)	Rep. Req.; Quarterly reports; Compliance Certification
40 CFR 75.64(d)	Rep. Req.; Quarterly reports; Electronic format
40 CFR 75.64(f)	Method of Submission
40 CFR 75.64(g)	Submission Requirements
40 CFR 75.66	Petitions to the Administrator (if required)
Appendix A	Specifications and Test Procedures
Appendix B	QA/QC Procedures
Appendix C.	Missing Data Estimation Procedures
Appendix D	Optional SO ₂ ; Oil-/gas-fired units
Appendix F	Conversion Procedures
Acid Rain Program-Excess Emissions:	
40 CFR 77.3	Offset Plans
40 CFR 77.5(b)	Deductions of Allowances
40 CFR 77.6	Excess Emissions Penalties (SO ₂)

ATTACHMENT PSNCT5A-5D_15

ACID RAIN APPLICATION



Jeb Bush
Governor

Department of Environmental Protection

Twin Towers Office Building
2600 Blair Stone Road
Tallahassee, Florida 32399-2400

David B. Struhs
Secretary

May 15, 2002

Mr. Ken Simmons
Manager, New Capacity Projects
Florida Power & Light Company
Environmental Services Department
P.O. 14000
Juno Beach, Florida 33408

Re: Revised Acid Rain Phase II Permit Application and Retired Unit Exemption Form
Sanford Plant

Facility ID: 1270009; ORIS Code: 0620

Dear Mr. Simmons:

Thank you for your recent submission of the Revised Acid Rain Phase II Permit Application and Retired Unit Exemption Form (for Unit PSN5) for the subject facility. We have reviewed both submissions and deem them complete. If you have questions, please contact Tom Cascio at 850/921-9526.

Sincerely,

A handwritten signature in black ink that reads "Scott M. Sheplak".

Scott M. Sheplak, P.E.
Administrator
Title V Section

cc: Jenny Jachim, U.S. EPA Region 4

"More Protection, Less Process"

Printed on recycled paper.



May 9, 2002

Scott M. Sheplak
Bureau of Air Regulation
State of Florida
Department of Environmental Protection
2600 Blair Stone Road
Mail Station #5505
Tallahassee, FL 32399-2400

**Re: FPL's Sanford Plant (ORIS Code 000620)
Revised Acid Rain Phase II Application
Retired Unit Exemption Form (40 CFR 72.8)**

Dear Sirs:

Enclosed please find copies of the above referenced forms for FPL's Sanford generating facility.

The Sanford station is an existing facility for which FPL submitted a revised Phase II application for the repowering of two (2) existing oil-fired steam boiler units with eight (8), combined cycle combustion turbines in August of 1999.

The attached are submitted to:

- 1) Remove PSN5 from the Phase II Application (taken out of service in October of 2001) and to change the commence operation date for PSNCT4A thru PSNCT4D and PSNCT5A thru PSN5D to FPL's target dates indicated on this revised Application.
- 2) The Retired Unit Exemption is submitted to indicate the first full calendar year in which the units PSN5 (ORIS Code 000620) will meet the requirements of 40 CFR 72.8(d)

If further information is desired please contact me at (561) 691 - 2216 or via e-mail at the following address, k_h_simmons@fpl.com.

Sincerely,

A handwritten signature in black ink, appearing to read 'K.H. Simmons', is written over a horizontal line.

Ken Simmons
Manager, New Capacity Projects
Juno Environmental services

Cc:
USEPA
Acid Rain Program



May 9, 2002

Mr. Bob Miller
US EPA Acid Rain Program
633 3rd St., NW
Washington, DC 20001
(202) 564 - 9150

**Re: FPL's Sanford Plant (ORIS Code 000620)
Revised Acid Rain Phase II Application
Retired Unit Exemption Form (40 CFR 72.8)**

Dear Sirs:

Enclosed please find copies of the above referenced forms for FPL's Sanford generating facility.

The Sanford station is an existing facility for which FPL submitted a revised Phase II application for the repowering of two (2) existing oil-fired steam boiler units with eight (8), combined cycle combustion turbines in August of 1999.

The attached are submitted to:

- 1) Remove PSN5 from the Phase II Application (taken out of service in October of 2001) and to change the commence operation date for PSNCT4A thru PSNCT4D and PSNCT5A thru PSN5D to FPL's target dates indicated on this revised Application.
- 2) The Retired Unit Exemption is submitted to indicate the first full calendar year in which the units PSN5 (ORIS Code 000620) will meet the requirements of 40 CFR 72.8(d)

If further information is desired please contact me at (561) 691 - 2216 or via e-mail at the following address, k_h_simmons@fpl.com.

Sincerely,

A handwritten signature in black ink that reads 'K.H. Simmons'.

Ken Simmons
Manager, New Capacity Projects
Juno Environmental services

Cc:
Tom Casio FDEP
Acid Rain Program

Retired Unit Exemption

For more information, see instructions and refer to Rule 62-214.340(2), F.A.C., and 40 CFR 72.8

This submission is: New Revised

Page 1

STEP 1
Identify the unit by plant name,
State, ORIS code and unit ID#.

Plant Name Sanford	State FL	000620 ORIS Code	PSN5 Unit ID#
--------------------	----------	---------------------	------------------

STEP 2
Identify the first full calendar year in
which the unit meets (or will meet) the
requirements of Rule 62-214.340(2)(a),
F.A.C.

January 1, 2002_____

STEP 3
Read the special provisions.

Special Provisions

(1) A unit exempt under Rule 62-214.340(2), F.A.C., shall not emit any sulfur dioxide and nitrogen oxides starting on the date that the exemption takes effect. The owners and operators of the unit will be allocated allowances in accordance with 40 CFR part 73 subpart B. If the unit is a Phase I unit, for each calendar year in Phase I, the designated representative of the unit shall submit a Phase I permit application in accordance with 40 CFR part 72 subparts C and D and an annual certification report in accordance with 40 CFR 72.90 through 72.92 and is subject to 40 CFR 72.95 and 72.96.

(2) A unit exempt under Rule 62-214.340(2), F.A.C., shall not resume operation unless the designated representative of the source that includes the unit submits a complete Acid Rain part application under Rule 62-214.320, F.A.C., for the unit not less than 24 months prior to the date on which the unit is first to resume operation.

(3) The owners and operators and, to the extent applicable, the designated representative of a unit exempt under Rule 62-214.340(2), F.A.C., shall comply with the requirements of Chapter 62-214, F.A.C., and the Acid Rain Program concerning all periods for which the exemption is not in effect, even if such requirements arise, or must be complied with, after the exemption takes effect.

(4) For any period for which a unit is exempt under Rule 62-214.340(2), F.A.C., the unit is not an Acid Rain unit and is not eligible to be an opt-in source under 40 CFR part 74. As a non-Acid Rain Unit, the unit shall continue to be subject to any other applicable requirements under 40 CFR part 70.

(5) For a period of 5 years from the date the records are created, the owners and operators of a unit exempt under Rule 62-214.340(2), F.A.C., shall retain at the source that includes the unit records demonstrating that the unit is permanently retired. The 5-year period for keeping records may be extended for cause, at any time prior to the end of the period, in writing by the EPA or the Department. The owners and operators bear the burden of proof that the unit is permanently retired.

(6) On the earlier of the following dates, a unit exempt under Rule 62-214.340(2), F.A.C., shall lose its exemption and become an Acid Rain Unit: (i) the date on which the designated representative submits an Acid Rain part application under paragraph (2); or (ii) the date on which the designated representative is required under paragraph (2) to submit an Acid Rain part application. For the purpose of applying monitoring requirements under 40 CFR part 75, a unit that loses its exemption under Rule 62-214.340(2), F.A.C., shall be treated as a new unit that commenced commercial operation on the first date on which the unit resumes operation.

STEP 4
Read the appropriate certification
and sign and date.

Certification (for designated representatives only)

I am authorized to make this submission on behalf of the owners and operators of the Acid Rain source or Acid Rain units for which the submission is made. I certify under penalty of law that I have personally examined, and am familiar with, the statements and information submitted in this document and all its attachments. Based on my inquiry of those individuals with primary responsibility for obtaining the information, I certify that the statements and information are to the best of my knowledge and belief true, accurate, and complete. I am aware that there are significant penalties for submitting false statements and information or omitting required statements and information, including the possibility of fine or imprisonment.

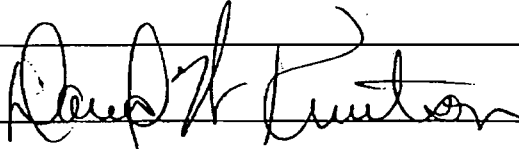
Name David W Knutson	
Signature 	Date 4/30/02

Plant Name (from Step 1) Sanford Plant

Retired Unit Exemption

Page 2

STEP 4, cont'd.
Read the appropriate
certification and sign
and date.

Certification (for certifying officials only)

I certify under penalty of law that I have personally examined, and am familiar with, the statements and information submitted in this document and all its attachments. Based on my inquiry of those individuals with primary responsibility for obtaining the information, I certify that the statements and information are to the best of my knowledge and belief true, accurate, and complete. I am aware that there are significant penalties for submitting false statements and information or omitting required statements and information, including the possibility of fine or imprisonment.

Name	
Signature	Date

Certification (for additional certifying officials, if applicable)

I certify under penalty of law that I have personally examined, and am familiar with, the statements and information submitted in this document and all its attachments. Based on my inquiry of those individuals with primary responsibility for obtaining the information, I certify that the statements and information are to the best of my knowledge and belief true, accurate, and complete. I am aware that there are significant penalties for submitting false statements and information or omitting required statements and information, including the possibility of fine or imprisonment.

Name	
Signature	Date

Certification (for additional certifying officials, if applicable)

I certify under penalty of law that I have personally examined, and am familiar with, the statements and information submitted in this document and all its attachments. Based on my inquiry of those individuals with primary responsibility for obtaining the information, I certify that the statements and information are to the best of my knowledge and belief true, accurate, and complete. I am aware that there are significant penalties for submitting false statements and information or omitting required statements and information, including the possibility of fine or imprisonment.

Name	
Signature	Date

Acid Rain Program

Instructions for Retired Unit Exemption

Form (Rule 62-214.340(2), F.A.C., and 40 CFR 72.8)

The Acid Rain regulations provide that an Acid Rain unit that is permanently retired is exempted from the requirements to obtain a Phase II acid rain part, monitor emissions, and hold allowances, except for requirements concerning reduced utilization in Phase I (1995-1999). The designated representative or certifying official(s) of such a unit must submit the Retired Unit Exemption form. The provisions governing the retired unit exemption are found at Rule 62-214.340(2), F.A.C.

Please type or print. If assistance is needed, contact the title V permitting authority.

STEP 1 Use the plant name and ORIS code listed on the Certificate of Representation (if any) for the Acid Rain source. An ORIS code is a 4 digit number assigned by the Energy Information Agency (EIA) at the U.S. Department of Energy to power plants owned by utilities. If the plant is not owned by a utility but has a 5 digit facility code (also assigned by EIA), use the facility code. If there is uncertainty regarding what the code number is, contact EIA at (202) 426-1234 (for ORIS codes), or (202) 426-1269 (for facility codes).

Identify the Acid Rain unit by providing the appropriate unit identification number. The identification number entered for the unit should be consistent with the Certificate of Representation (if any) for the Acid Rain source, with the unit identification numbers listed in NADB (for units that commenced operation prior to 1993), and with the unit identification number used in reporting to DOE and/or EIA. NADB is the National Allowance Data Base for the Acid Rain Program, and can be downloaded from the Acid Rain Program Website at www.epa.gov/acidrain/ or obtained on diskette by calling the Acid Rain Hotline at (202) 564-9620. This data file is in dBase format for use on an IBM-compatible PC and requires 2 megabytes of hard drive memory.

STEP 2 Enter the first full calendar year in which the unit is permanently retired. The exemption becomes effective January 1 of that year, but the unit may lose the exemption as provided in 40 CFR 72.8(d)(6).

STEP 4 For a unit for which a designated representative has been authorized, the designated representative or alternate designated representative must read, sign, and date the certification at STEP 4 labeled "for designated representatives only" and submit this form.

If no designated representative has been authorized, a certifying official for each owner of the unit must read, sign, and date the certification at STEP 4 labeled "for certifying officials only" and submit this form. A certifying official is not required to submit a Certificate of Representation. If there is more than one owner of a unit for which no designated representative has been authorized, each owner of the unit must have a certifying official sign the appropriate certification at STEP 4.

Submission Deadlines

The form must be submitted by December 31 of the first year in which the unit is to be exempt.

Submission Instructions

Submit this form and 1 copy to the appropriate title V air permitting authority and a copy to:

U.S. Environmental Protection Agency
Acid Rain Program (6204J)
Attn: Retired Unit Exemption
401 M St., SW
Washington, DC 20460.

If you have questions regarding this form, contact your local, State, or EPA Regional acid rain contact, or call EPA's Acid Rain Hotline at (202) 564-9620.

Phase II Acid Rain Part Application

For more information, see instructions and refer to 40 CFR 72.30 and 72.31 and Chapter 62-214, F.A.C.

This submission is: New Revised

STEP 1

Identify the source by plant name, State, and ORIS code from NADB

Plant Name Sanford Plant	State FL	ORIS Code 000620
--------------------------	----------	------------------

STEP 2 Enter the unit ID# for each affected unit and indicate whether a unit is being repowered and the repowering plan being renewed by entering "yes" or "no" at column c. For new units, enter the requested information in columns d and e.

Compliance Plan				
a	b	c	d	e
Unit ID#	Unit will hold allowances in accordance with 40 CFR 72.9(c)(1)	Repowering Plan	New Units Commence Operation Date	New Units Monitor Certification Deadline
PSN3	Yes	N/A	N/A	N/A
PSN4	Yes	N/A	N/A	N/A
PSNCT4A	Yes	N/A	12/16/2002	3/16/2003
PSNCT4B	Yes	N/A	12/23/2002	3/23/2003
PSNCT4C	Yes	N/A	12/30/2002	3/30/2003
PSNCT4D	Yes	N/A	01/06/2003	4/6/2003
PSNCT5A	Yes	N/A	2/21/2002	5/6/2002
PSNCT5B	Yes	N/A	2/25/2002	5/7/2002
PSNCT5C	Yes	N/A	3/4/2002	5/8/2002
PSNCT5D	Yes	N/A	3/11/2002	5/13/2002
	Yes			
	Yes			

STEP 3

Check the box if the response in column c of Step 2 is "Yes" for any unit

For each unit that is being repowered, the Repowering Extension Plan form is included.

Plant Name (from Step 1)

STEP 4

Read the standard requirements and certification, enter the name of the designated representative, and sign and date

Standard RequirementsAcid Rain Part Requirements.

- (1) The designated representative of each Acid Rain source and each Acid Rain unit at the source shall:
 - (i) Submit a complete Acid Rain part application (including a compliance plan) under 40 CFR part 72 and Rules 62-214.320 and 330, F.A.C., in accordance with the deadlines specified in Rule 62-214.320, F.A.C.; and
 - (ii) Submit in a timely manner any supplemental information that the Department determines is necessary in order to review an Acid Rain part application and issue or deny an Acid Rain part.
- (2) The owners and operators of each Acid Rain source and each Acid Rain unit at the source shall:
 - (i) Operate the unit in compliance with a complete Acid Rain part application or a superseding Acid Rain part issued by the Department; and
 - (ii) Have an Acid Rain Part.

Monitoring Requirements.

- (1) The owners and operators and, to the extent applicable, designated representative of each Acid Rain source and each Acid Rain unit at the source shall comply with the monitoring requirements as provided in 40 CFR part 75, and Rule 62-214.420, F.A.C.
- (2) The emissions measurements recorded and reported in accordance with 40 CFR part 75 shall be used to determine compliance by the unit with the Acid Rain emissions limitations and emissions reduction requirements for sulfur dioxide and nitrogen oxides under the Acid Rain Program.
- (3) The requirements of 40 CFR part 75 shall not affect the responsibility of the owners and operators to monitor emissions of other pollutants or other emissions characteristics at the unit under other applicable requirements of the Act and other provisions of the operating permit for the source.

Sulfur Dioxide Requirements.

- (1) The owners and operators of each source and each Acid Rain unit at the source shall:
 - (i) Hold allowances, as of the allowance transfer deadline, in the unit's compliance subaccount (after deductions under 40 CFR 73.34(c)) not less than the total annual emissions of sulfur dioxide for the previous calendar year from the unit; and
 - (ii) Comply with the applicable Acid Rain emissions limitations for sulfur dioxide.
- (2) Each ton of sulfur dioxide emitted in excess of the Acid Rain emissions limitations for sulfur dioxide shall constitute a separate violation of the Act.
- (3) An Acid Rain unit shall be subject to the requirements under paragraph (1) of the sulfur dioxide requirements as follows:
 - (i) Starting January 1, 2000, an Acid Rain unit under 40 CFR 72.6(a)(2); or
 - (ii) Starting on the later of January 1, 2000 or the deadline for monitor certification under 40 CFR part 75, an Acid Rain unit under 40 CFR 72.6(a)(3).
- (4) Allowances shall be held in, deducted from, or transferred among Allowance Tracking System accounts in accordance with the Acid Rain Program.
- (5) An allowance shall not be deducted in order to comply with the requirements under paragraph (1)(i) of the sulfur dioxide requirements prior to the calendar year for which the allowance was allocated.
- (6) An allowance allocated by the Administrator under the Acid Rain Program is a limited authorization to emit sulfur dioxide in accordance with the Acid Rain Program. No provision of the Acid Rain Program, the Acid Rain part application, the Acid Rain part, or an exemption under 40 CFR 72.7, 72.8, or 72.14 and no provision of law shall be construed to limit the authority of the United States to terminate or limit such authorization.
- (7) An allowance allocated by the Administrator under the Acid Rain Program does not constitute a property right.

Nitrogen Oxides Requirements. The owners and operators of the source and each Acid Rain unit at the source shall comply with the applicable Acid Rain emissions limitation for nitrogen oxides.

Excess Emissions Requirements.

- (1) The designated representative of an Acid Rain unit that has excess emissions in any calendar year shall submit a proposed offset plan, as required under 40 CFR part 77.
- (2) The owners and operators of an Acid Rain unit that has excess emissions in any calendar year shall:
 - (i) Pay without demand the penalty required, and pay upon demand the interest on that penalty, as required by 40 CFR part 77; and
 - (ii) Comply with the terms of an approved offset plan, as required by 40 CFR part 77.

Recordkeeping and Reporting Requirements.

- (1) Unless otherwise provided, the owners and operators of the source and each Acid Rain unit at the source shall keep on site at the source each of the following documents for a period of 5 years from the date the document is created. This period may be extended for cause, at any time prior to the end of 5 years, in writing by the EPA or the Department:
 - (i) The certificate of representation for the designated representative for the source and each Acid Rain unit at the source and all documents that demonstrate the truth of the statements in the certificate of representation, in accordance with Rule 62-214.350, F.A.C.; provided that the certificate and documents shall be retained on site at the source beyond such 5-year period until such documents are superseded because of the submission of a new certificate of representation changing the designated representative;
 - (ii) All emissions monitoring information, in accordance with 40 CFR part 75, provided that to the extent that 40 CFR part 75 provides for a 3-year period for recordkeeping, the 3-year period shall apply;
 - (iii) Copies of all reports, compliance certifications, and other submissions and all records made or required under the Acid Rain Program; and

Plant Name (from Step 1)

Recordkeeping and Reporting Requirements (cont)

- (iv) Copies of all documents used to complete an Acid Rain part application and any other submission under the Acid Rain Program or to demonstrate compliance with the requirements of the Acid Rain Program.
- (2) The designated representative of an Acid Rain source and each Acid Rain unit at the source shall submit the reports and compliance certifications required under the Acid Rain Program, including those under 40 CFR part 72 subpart I and 40 CFR part 75.

Liability.

- (1) Any person who knowingly violates any requirement or prohibition of the Acid Rain Program, a complete Acid Rain part application, an Acid Rain part, or an exemption under 40 CFR 72.7, 72.8 or 72.14, including any requirement for the payment of any penalty owed to the United States, shall be subject to enforcement pursuant to section 113(c) of the Act.
- (2) Any person who knowingly makes a false, material statement in any record, submission, or report under the Acid Rain Program shall be subject to criminal enforcement pursuant to section 113(c) of the Act and 18 U.S.C. 1001.
- (3) No permit revision shall excuse any violation of the requirements of the Acid Rain Program that occurs prior to the date that the revision takes effect.
- (4) Each Acid Rain source and each Acid Rain unit shall meet the requirements of the Acid Rain Program.
- (5) Any provision of the Acid Rain Program that applies to an Acid Rain source (including a provision applicable to the designated representative of an Acid Rain source) shall also apply to the owners and operators of such source and of the Acid Rain units at the source.
- (6) Any provision of the Acid Rain Program that applies to an Acid Rain unit (including a provision applicable to the designated representative of an Acid Rain unit) shall also apply to the owners and operators of such unit. Except as provided under 40 CFR 72.44 (Phase II repowering extension plans) and 40 CFR 76.11 (NO_x averaging plans), and except with regard to the requirements applicable to units with a common stack under 40 CFR part 75 (including 40 CFR 75.16, 75.17, and 75.18), the owners and operators and the designated representative of one Acid Rain unit shall not be liable for any violation by any other Acid Rain unit of which they are not owners or operators or the designated representative and that is located at a source of which they are not owners or operators or the designated representative.
- (7) Each violation of a provision of 40 CFR parts 72, 73, 75, 76, 77, and 78 by an Acid Rain source or Acid Rain unit, or by an owner or operator or designated representative of such source or unit, shall be a separate violation of the Act.

Effect on Other Authorities. No provision of the Acid Rain Program, an Acid Rain part application, an Acid Rain part, or an exemption under 40 CFR 72.7, 72.8, or 72.14 shall be construed as:

- (1) Except as expressly provided in title IV of the Act, exempting or excluding the owners and operators and, to the extent applicable, the designated representative of an Acid Rain source or Acid Rain unit from compliance with any other provision of the Act, including the provisions of title I of the Act relating to applicable National Ambient Air Quality Standards or State Implementation Plans;
- (2) Limiting the number of allowances a unit can hold; *provided*, that the number of allowances held by the unit shall not affect the source's obligation to comply with any other provisions of the Act;
- (3) Requiring a change of any kind in any State law regulating electric utility rates and charges, affecting any State law regarding such State regulation, or limiting such State regulation, including any prudence review requirements under such State law;
- (4) Modifying the Federal Power Act or affecting the authority of the Federal Energy Regulatory Commission under the Federal Power Act; or
- (5) Interfering with or impairing any program for competitive bidding for power supply in a State in which such program is established.

Certification

I am authorized to make this submission on behalf of the owners and operators of the Acid Rain source or Acid Rain units for which the submission is made. I certify under penalty of law that I have personally examined, and am familiar with, the statements and information submitted in this document and all its attachments. Based on my inquiry of those individuals with primary responsibility for obtaining the information, I certify that the statements and information are to the best of my knowledge and belief true, accurate, and complete. I am aware that there are significant penalties for submitting false statements and information or omitting required statements and information, including the possibility of fine or imprisonment.

Name	David W. Kaytson	
Signature	David W. Kaytson	Date 4-30-02

Acid Rain Program

Instructions for Phase II Acid Rain Part Application

(40 CFR 72.30 - 72.31 and Rule 62-214.320, F.A.C.)

The Acid Rain Program regulations require the designated representative to submit an Acid Rain part application for Phase II for each source with an Acid Rain unit. A complete Phase II part application is binding on the owners and operators of the Acid Rain source and is enforceable in the absence of an Acid Rain part until the permitting authority either issues an Acid Rain part to the source or disapproves the application.

Please type or print. The alternate designated representative may sign in lieu of the designated representative. If assistance is needed, contact the title V permitting authority.

STEP 1 Use the plant name and ORIS Code listed on the Certificate of Representation for the plant. An ORIS code is a 4 digit number assigned by the Energy Information Agency (EIA) at the U.S. Department of Energy to power plants owned by utilities. If the plant is not owned by a utility but has a 5 digit facility code (also assigned by EIA), use the facility code. If no code has been assigned or if there is uncertainty regarding what the code number is, contact EIA at (202) 426-1234 (for ORIS codes), or (202) 426-1269 (for facility codes).

STEP 2 For column "a," identify each Acid Rain unit at the Acid Rain source by providing the appropriate unit identification numbers, consistent with the unit identification numbers entered on the Certificate of Representation, with unit identification numbers listed in NADB (for units that commenced operation prior to 1993), and with unit identification numbers used in reporting to DOE and/or EIA. For new units without identification numbers, owners and operators may assign such numbers consistent with EIA and DOE requirements. NADB is the National Allowance Data Base for the Acid Rain Program, and can be downloaded from the Acid Rain Program Website at "www.epa.gov/acidrain/" or obtained on diskette by calling the Acid Rain Hotline. This data file is in dBase format for use on an IBM-compatible PC and requires 2 megabytes of hard drive memory.

For column "c," enter "yes" only if a repowering technology petition has been approved for the unit by U.S. EPA, an initial repowering extension plan was approved by the title V permitting authority and activated by the designated representative, and a repowering extension plan renewing the original repowering extension plan has been included with the current acid rain part application for that unit.

For columns "d" and "e," enter the commence operation date(s) and monitor certification deadline(s) for new units in accordance with 40 CFR 75.4. If the commence operation date or monitor certification date changes after the Phase II part is issued, the designated representative must submit a request for an administrative correction under Rule 62-214.370(6), F.A.C.

Submission Deadlines

For new units, an initial Phase II part application must be submitted to the title V permitting authority at least 24 months before the date the unit commences operation. Phase II acid rain renewal applications must be submitted at least 6 months in advance of the expiration of the acid rain portion of a title V permit, or such longer time as provided for under the title V permitting authority's operating permits regulation.

Submission Instructions

Submit this form and 1 copy to the appropriate title V air permitting authority. If you have questions regarding this form, contact your local, State, or EPA Regional acid rain contact, or call EPA's Acid Rain Hotline at (202) 564-9620.

III. EMISSIONS UNIT INFORMATION

A separate Emissions Unit Information Section (including subsections A through J as required) must be completed for each emissions unit addressed in this Application for Air Permit. If submitting the application form in hard copy, indicate, in the space provided at the top of each page, the number of this Emissions Unit Information Section and the total number of Emissions Unit Information Sections submitted as part of this application.

**A. GENERAL EMISSIONS UNIT INFORMATION
(All Emissions Units)**

Emissions Unit Description and Status

<p>1. Type of Emissions Unit Addressed in This Section: (Check one)</p> <p><input type="checkbox"/> This Emissions Unit Information Section addresses, as a single emissions unit, a single process or production unit, or activity, which produces one or more air pollutants and which has at least one definable emission point (stack or vent).</p> <p><input type="checkbox"/> This Emissions Unit Information Section addresses, as a single emissions unit, a group of process or production units and activities which has at least one definable emission point (stack or vent) but may also produce fugitive emissions.</p> <p><input checked="" type="checkbox"/> This Emissions Unit Information Section addresses, as a single emissions unit, one or more process or production units and activities which produce fugitive emissions only.</p>			
<p>2. Regulated or Unregulated Emissions Unit? (Check one)</p> <p><input type="checkbox"/> The emissions unit addressed in this Emissions Unit Information Section is a regulated emissions unit.</p> <p><input checked="" type="checkbox"/> The emissions unit addressed in this Emissions Unit Information Section is an unregulated emissions unit.</p>			
<p>3. Description of Emissions Unit Addressed in This Section (limit to 60 characters): Wet Surface Air cooling - two units are addressed for use with Unit 5.</p>			
<p>4. Emissions Unit Identification Number: <input type="checkbox"/> No ID ID: 13 <input type="checkbox"/> ID Unknown</p>			
<p>5. Emissions Unit Status Code: C</p>	<p>6. Initial Startup Date: 21 FEB 2002 Est.</p>	<p>7. Emissions Unit Major Group SIC Code: 49</p>	<p>8. Acid Rain Unit? <input type="checkbox"/></p>
<p>9. Emissions Unit Comment: (Limit to 500 Characters)</p> <p>Wet Surface Air Cooling unit which uses surface water to cool closed cooling water. A small portion of the surface water will be emitted as drift which will form particulate matter (see Attachment PSN-EU13-A9).</p>			

Emissions Unit Control Equipment

1. Control Equipment/Method Description (Limit to 200 characters per device or method):

Wet Surface Air Coolers: Mist Eliminator

2. Control Device or Method Code(s): **014**

Emissions Unit Details

1. Package Unit: Wet Surface Air Coolers		
Manufacturer:		Model Number:
2. Generator Nameplate Rating:	NA	MW
3. Incinerator Information:		
	Dwell Temperature:	°F
	Dwell Time:	seconds
	Incinerator Afterburner Temperature:	°F

**B. EMISSIONS UNIT CAPACITY INFORMATION
(Regulated Emissions Units Only)**

Emissions Unit Operating Capacity and Schedule

1. Maximum Heat Input Rate:		mmBtu/hr
2. Maximum Incineration Rate:	lb/hr	tons/day
3. Maximum Process or Throughput Rate:		
4. Maximum Production Rate:		
5. Requested Maximum Operating Schedule:		
	hours/day	days/week
	weeks/year	8,760 hours/year
6. Operating Capacity/Schedule Comment (limit to 200 characters):		

**C. EMISSIONS UNIT REGULATIONS
(Regulated Emissions Units Only)**

List of Applicable Regulations

NA

D. EMISSION POINT (STACK/VENT) INFORMATION
(Regulated Emissions Units Only)

Emission Point Description and Type

1. Identification of Point on Plot Plan or Flow Diagram?		2. Emission Point Type Code:	
3. Descriptions of Emission Points Comprising this Emissions Unit for VE Tracking (limit to 100 characters per point):			
4. ID Numbers or Descriptions of Emission Units with this Emission Point in Common:			
5. Discharge Type Code:	6. Stack Height: feet	7. Exit Diameter: feet	
8. Exit Temperature: °F	9. Actual Volumetric Flow Rate: acfm	10. Water Vapor: %	
11. Maximum Dry Standard Flow Rate: dscfm		12. Nonstack Emission Point Height: feet	
13. Emission Point UTM Coordinates: Zone: East (km): North (km):			
14. Emission Point Comment (limit to 200 characters): See Attachment PSN-A9.			

E. SEGMENT (PROCESS/FUEL) INFORMATION
(All Emissions Units)

Segment Description and Rate: Segment 1 of 1

1. Segment Description (Process/Fuel Type) (limit to 500 characters): Circulating Water Rate		
2. Source Classification Code (SCC):		3. SCC Units:
4. Maximum Hourly Rate: 6.7	5. Maximum Annual Rate: 58,569	6. Estimated Annual Activity Factor:
7. Maximum % Sulfur:	8. Maximum % Ash:	9. Million Btu per SCC Unit:
10. Segment Comment (limit to 200 characters): Maximum Hourly Rate and Annual Rate in 1,000 gallons.		

Segment Description and Rate: Segment of

1. Segment Description (Process/Fuel Type) (limit to 500 characters):		
2. Source Classification Code (SCC):		3. SCC Units:
4. Maximum Hourly Rate:	5. Maximum Annual Rate:	6. Estimated Annual Activity Factor:
7. Maximum % Sulfur:	8. Maximum % Ash:	9. Million Btu per SCC Unit:
10. Segment Comment (limit to 200 characters):		

**F. EMISSIONS UNIT POLLUTANTS
(All Emissions Units)**

1. Pollutant Emitted	2. Primary Control Device Code	3. Secondary Control Device Code	4. Pollutant Regulatory Code
PM	014		NS
PM ₁₀	014		NS

G. EMISSIONS UNIT POLLUTANT DETAIL INFORMATION
(Regulated Emissions Units -
Emissions-Limited and Preconstruction Review Pollutants Only)

Potential/Fugitive Emissions

1. Pollutant Emitted: PM	2. Total Percent Efficiency of Control:	
3. Potential Emissions: 1.34 lb/hour	5.87 tons/year	4. Synthetically Limited? []
5. Range of Estimated Fugitive Emissions: [] 1 [] 2 [] 3 _____ to _____ tons/year		
6. Emission Factor: 0.001% Drift Reference:		7. Emissions Method Code: 2
8. Calculation of Emissions (limit to 600 characters): See Attachment PSN-EU13-A9.		
9. Pollutant Potential/Fugitive Emissions Comment (limit to 200 characters):		

Allowable Emissions Allowable Emissions _____ of _____

1. Basis for Allowable Emissions Code:	2. Future Effective Date of Allowable Emissions:	
3. Requested Allowable Emissions and Units:	lb/hour	tons/year
4. Equivalent Allowable Emissions:		
5. Method of Compliance (limit to 60 characters):		
6. Allowable Emissions Comment (Desc. of Operating Method) (limit to 200 characters):		

H. VISIBLE EMISSIONS INFORMATION
(Only Regulated Emissions Units Subject to a VE Limitation)

Visible Emissions Limitation: Visible Emissions Limitation _____ of _____

1. Visible Emissions Subtype:	2. Basis for Allowable Opacity: [] Rule [] Other
3. Requested Allowable Opacity: Normal Conditions: _____ % Exceptional Conditions: _____ % Maximum Period of Excess Opacity Allowed: _____ min/hour	
4. Method of Compliance:	
5. Visible Emissions Comment (limit to 200 characters):	

I. CONTINUOUS MONITOR INFORMATION
(Only Regulated Emissions Units Subject to Continuous Monitoring)

Continuous Monitoring System: Continuous Monitor _____ of _____

1. Parameter Code:	2. Pollutant(s):
3. CMS Requirement:	[] Rule [] Other
4. Monitor Information: Manufacturer: _____ Model Number: _____ Serial Number: _____	
5. Installation Date:	6. Performance Specification Test Date:
7. Continuous Monitor Comment (limit to 200 characters):	

**J. EMISSIONS UNIT SUPPLEMENTAL INFORMATION
(Regulated Emissions Units Only)**

Supplemental Requirements

1. Process Flow Diagram [] Attached, Document ID: _____ [X] Not Applicable [] Waiver Requested
2. Fuel Analysis or Specification [] Attached, Document ID: _____ [X] Not Applicable [] Waiver Requested
3. Detailed Description of Control Equipment [] Attached, Document ID: _____ [X] Not Applicable [] Waiver Requested
4. Description of Stack Sampling Facilities [] Attached, Document ID: _____ [X] Not Applicable [] Waiver Requested
5. Compliance Test Report [] Attached, Document ID: _____ [] Previously submitted, Date: _____ [X] Not Applicable
6. Procedures for Startup and Shutdown [] Attached, Document ID: _____ [X] Not Applicable [] Waiver Requested
7. Operation and Maintenance Plan [] Attached, Document ID: _____ [X] Not Applicable [] Waiver Requested
8. Supplemental Information for Construction Permit Application [] Attached, Document ID: _____ [X] Not Applicable
9. Other Information Required by Rule or Statute [] Attached, Document ID: _____ [X] Not Applicable
10. Supplemental Requirements Comment:

Additional Supplemental Requirements for Title V Air Operation Permit Applications

11. Alternative Methods of Operation [] Attached, Document ID: _____ [X] Not Applicable
12. Alternative Modes of Operation (Emissions Trading) [] Attached, Document ID: _____ [X] Not Applicable
13. Identification of Additional Applicable Requirements [] Attached, Document ID: _____ [X] Not Applicable
14. Compliance Assurance Monitoring Plan [] Attached, Document ID: _____ [X] Not Applicable
15. Acid Rain Part Application (Hard-copy Required) [] Acid Rain Part - Phase II (Form No. 62-210.900(1)(a)) Attached, Document ID: _____ [] Repowering Extension Plan (Form No. 62-210.900(1)(a)1.) Attached, Document ID: _____ [] New Unit Exemption (Form No. 62-210.900(1)(a)2.) Attached, Document ID: _____ [] Retired Unit Exemption (Form No. 62-210.900(1)(a)3.) Attached, Document ID: _____ [] Phase II NOx Compliance Plan (Form No. 62-210.900(1)(a)4.) Attached, Document ID: _____ [] Phase NOx Averaging Plan (Form No. 62-210.900(1)(a)5.) Attached, Document ID: _____ [X] Not Applicable

ATTACHMENT PSN-EU13-A9
EMISSIONS UNIT COMMENT

Golder Associates Inc.

6241 NW 23rd Street, Suite 500
Gainesville, FL 32653-1500
Telephone (352) 336-5600
Fax (352) 336-6603



April 18, 2001

9837571

Florida Department of Environmental Protection
Bureau of Air Regulation
Twin Towers Office Building
2600 Blair Stone Road
Tallahassee, FL 32399-2400

Attention: Mr. A. A. Linero, P.E., Administrator, New Source Review

RE: FPL Sanford Plant – 2,200-MW Gas Repowering Project
FDEP File No. 1270009-AC (PSD-FL-270)

Dear Al:

This correspondence is being submitted to update the Department on design enhancements made to the above-referenced project. The combined effect of these enhancements will be to reduce the emissions from the project.

First, the natural gas-fired fuel heaters, initially included with the project and listed in the air construction and Prevention of Significant Deterioration (PSD) permit, will not be constructed. Fuel heating will be accomplished using electric fuel heaters. There are no emissions associated with the electric heaters. As a result, emission unit Nos. 012 through 019, as identified in the air construction and PSD permit, will not exist. The specific conditions of the permit that address the fuel heaters are: Specific Condition III.5., III.10., III.15., III.18., and III.19.

Secondly, the mechanical draft-cooling tower, identified as emission unit No. 020 in the permit, is not being constructed. The cooling tower is listed as an unregulated emission unit. However, two smaller evaporative equipment coolers are being constructed for the project. One evaporative equipment cooler will be constructed for each unit (i.e., one for repowered Unit 4 and one for repowered Unit 5). The total particulate matter (PM) and particulate matter less than 10 microns (PM_{10}) emissions estimated for the cooling tower and included in the air permit application were 24.58 and 12.42 tons per year (TPY), respectively (see Table 2-11 in the air permit application). The maximum PM emissions from the two evaporative equipment coolers are 2.68 pounds per hour (lb/hr) and 11.74 TPY, respectively. The maximum PM_{10} emissions are estimated to be 1.34 lb/hr and 5.87 TPY, respectively. The emission calculations are:

$$6,686 \text{ gallons circulating water/minute/cooler} \times 2 \text{ coolers} \times 0.00001 \text{ gallon drift/gallon circulating water} \times 8.34 \text{ lb/gallon} \times 60 \text{ minutes/hr} \times 40,000 \text{ ppm maximum TDS(PM)/}10^6 = 2.68 \text{ lb/hr}$$

$$2.68 \text{ lb/hr} \times 8,760 \text{ hr/yr} \times \text{ton}/2,000 \text{ lb} = 11.74 \text{ tons PM/yr}$$

$$PM_{10} = \frac{1}{2} \text{ of PM}$$

The emissions associated with these equipment coolers are a result of the same process as the cooling tower but will be less than one-half that estimated for the cooling tower. The latest site plan (attached) identifies the evaporative equipment coolers as Item 17 on the drawing.

Please call if you have any questions.

Sincerely,

GOLDER ASSOCIATES INC.



Kennard F. Kosky, P.E.
Principal

KFK/nav

Enclosure-Site Plan

cc: Rich Piper, FPL

9837571a\041801.doc

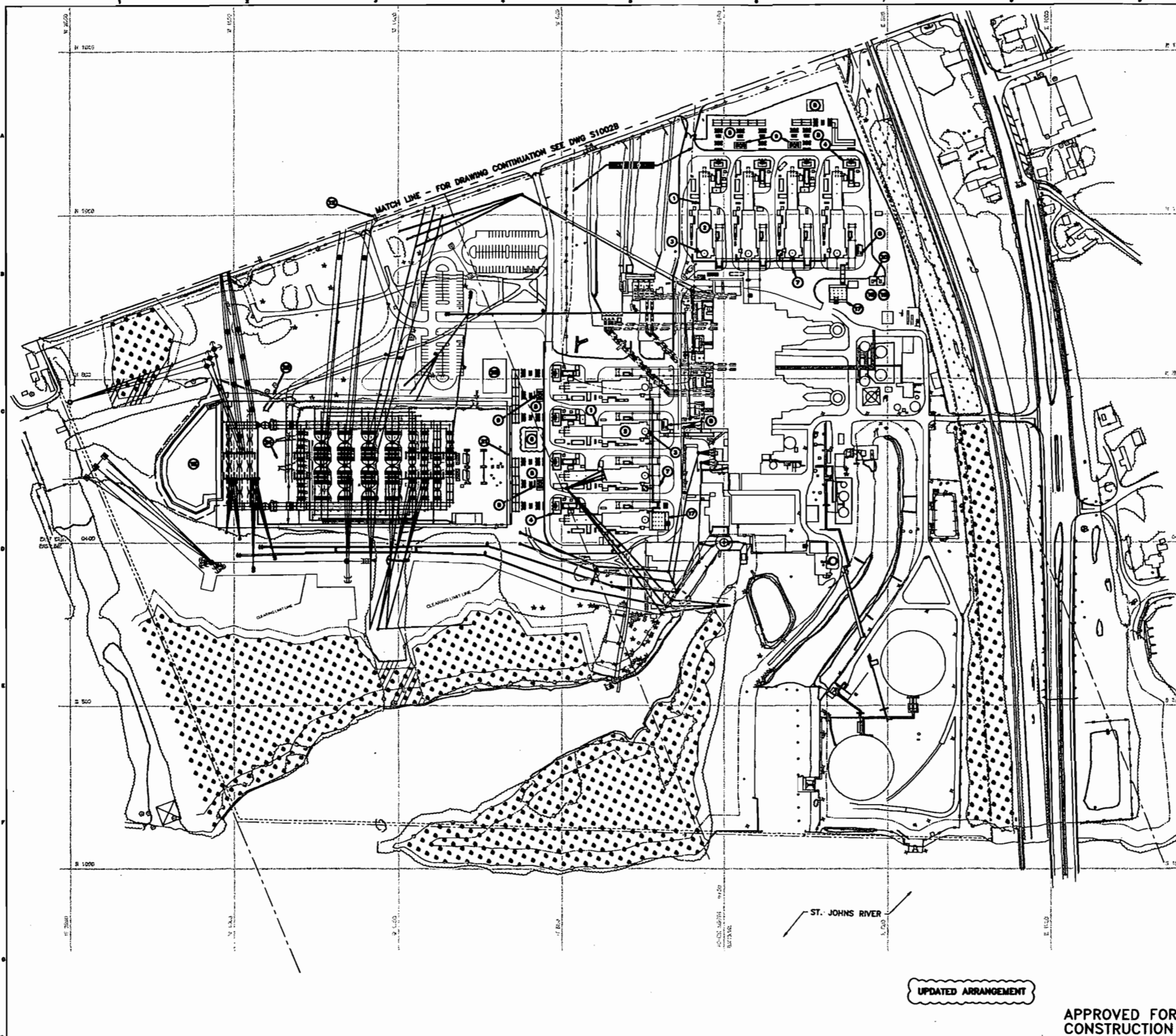

- NEW FACILITY LEGEND**
1. COMBUSTION TURBINE
 2. HEAT RECOVERY STEAM GENERATOR (HRSG)
 3. STACK
 4. GSI TRANSFORMER
 5. CT SWITCHYARD
 6. CT RELAY VAULT
 7. PIPE RACK
 8. SAMPLE BUILDING
 9. STATION SERVICE TRANSFORMERS NO. A & B
 10. NOT USED
 11. NOT USED
 12. PEDESTRIAN CROSSING
 13. NOT USED
 14. NOT USED
 15. NOT USED
 16. NOT USED
 17. EVAPORATIVE COOLER
 18. STEAMWATER POND
 19. FIRE WATER STORAGE TANK
 20. FIRE WATER PUMP ENCLOSURE
 21. STEAMWATER CONTAMINANT CURB
 22. BRBM
 23. NOT USED
 24. TELECOMMUNICATION ENCLOSURE
 25. MAINTENANCE LAYOUT AREA
 26. NOT USED
 27. NOT USED

NOTES

1. THE COOLING WATER RESERVOIR EXCLUSION ZONE IS MEASURED FROM THE CENTERLINE OF THE BEHM AND IS EQUAL TO THE GREATER OF 10 TIMES THE DIFFERENCE BETWEEN THE TOP OF THE BEHM ELEVATION AND NATURAL GRADE OR 20 TIMES THE DIFFERENCE BETWEEN COOLING WATER RESERVOIR SURFACE ELEVATION AND GRADE. THE COOLING WATER RESERVOIR NORMAL OPERATING LEVEL IS PLANT ELEVATION 104.81 (ELEVATION 24.5 FT ABOVE OF 100M MEAN SEA LEVEL). EQUIPMENT AND WORK ACTIVITIES ARE NOT ALLOWED WITHIN THE EXCLUSION ZONE WITHOUT PRIOR APPROVAL OF THE CONSTRUCTION MANAGER AND DAM SAFETY COORDINATOR.

- LEGEND**
- PROPERTY LINE
 - PROJECT AREA BOUNDARY
 - CONSTRUCTION BUFFER FROM RIVER/WETLAND
 - SECTION LINE
 - EXISTING FACILITIES
 - NEW FACILITIES
 - ▨ WETLANDS
 - ▨ EXISTING TRANSMISSION LINE CORRIDOR
 - TREE BUFFER ZONE
 - ⊙ BENCHMARK

UPDATED ARRANGEMENT

APPROVED FOR CONSTRUCTION

3	05-13-2000	GENERAL REVISIONS	
2	03-27-2000	GENERAL REVISIONS	
1	01-13-2000	APPROVED FOR CONSTRUCTION	
0	10-15-99	DESIGN ISSUE	
REV	DATE	REVISIONS AND RECORD OF DATE	

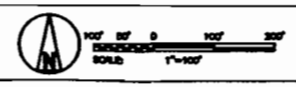

BLACK & VEATCH

PROJECT NO. 81282-9STU-S1002A
 SHEET NO. 3
 DATE 07-12-2000

FLORIDA POWER & LIGHT
SANFORD REPOWERING PROJECT
 GENERAL-SITE ARRANGEMENT
 SOUTH OF BARWICK ROAD

PROJECT NUMBER
81282-9STU-S1002A

SHEET NUMBER
3

FIGURE
Figure C-2