

DEPARTMENT OF ENVIRONMENTAL REGULATION  
**RECEIVED**

#5,000pd.  
5-22-90  
Receipt #151127

PSD-FL-150  
AC64-180842

MAY 22 1990

DER-BAQM

APPLICATION TO OPERATE/CONSTRUCT AIR POLLUTION SOURCES

SOURCE TYPE: Fossil Fuel Steam Generator [ ] New<sup>1</sup> [X] Existing<sup>1</sup> Orimulsion Test Burn

APPLICATION TYPE: [X] Construction [X] Operation [ ] Modification See Note a Below

COMPANY NAME: Florida Power & Light Company COUNTY: Volusia

Identify the specific emission point source(s) addressed in this application (i.e., Lime Kiln No. 4 with Venturi Scrubber; Peaking Unit No. 2, Gas Fired) Sanford Unit 4 - 400 MW class unit

SOURCE LOCATION: Street Lake Monroe off Highway 17-92 City Sanford

UTM: East 17-468.3 North 3190.3

Latitude 28 ° 50 ' 31 "N Longitude 81 ° 19 ' 32 "W

APPLICANT NAME AND TITLE: Martin A. Smith, Ph.D., Mgr. Environmental Permitting & Programs

APPLICANT ADDRESS: P.O. Box 078768, West Palm Beach, FL 33407-0768

SECTION I: STATEMENTS BY APPLICANT AND ENGINEER

A. APPLICANT

I am the undersigned owner or authorized representative\* of Florida Power & Light Company

I certify that the statements made in this application for a construction permit are true, correct and complete to the best of my knowledge and belief. Further, I agree to maintain and operate the pollution control source and pollution control facilities in such a manner as to comply with the provision of Chapter 403, Florida Statutes, and all the rules and regulations of the department and revisions thereof. I also understand that a permit, if granted by the department, will be non-transferable and I will promptly notify the department upon sale or legal transfer of the permitted establishment.

\*Attach letter of authorization

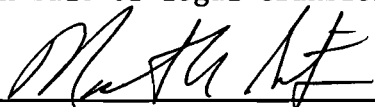
Signed: 

Martin A. Smith, Ph.D., Mgr., Env. Permitting & Programs  
Name and Title (Please Type)

Date: 5/21/90 Telephone No. (407) 640-2030

B. PROFESSIONAL ENGINEER REGISTERED IN FLORIDA (where required by Chapter 471, F.S.)

This is to certify that the engineering features of this pollution control project have been ~~designed~~/examined by me and found to be in conformity with modern engineering principles applicable to the treatment and disposal of pollutants characterized in the permit application. There is reasonable assurance, in my professional judgement, that

<sup>1</sup>See Florida Administration Code Rule 17-2.100(57) and (104)

<sup>2</sup>Approval under the testing and research provisions of FDER Rule 17-103.120 would authorized FPL to both construct and operate Unit 4 when firing Orimulsion fuel.

the pollution control facilities, when properly maintained and operated, will discharge an effluent that complies with all applicable statutes of the State of Florida and the rules and regulations of the department. ~~It is also agreed that the undersigned will furnish, if authorized by the owner, the applicant a set of instructions for the proper maintenance and operation of the pollution control facilities and, if applicable, pollution sources.~~  
(Source already operating)

Signed                     Kennard F. Kosky                      
                    Kennard F. Kosky                      
                    Name (Please Type)  
                    KBN Engineering and Applied Sciences, Inc.                      
                    Company Name (Please Type)  
                    1034 N.W. 57th Street, Gainesville, FL 32605                      
                    Mailing Address (Please Type)

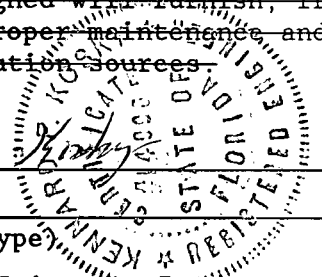

Florida Registration No. 14996 Date: 5/21/90 Telephone No. (904) 331-9000

SECTION II: GENERAL PROJECT INFORMATION

A. Describe the nature and extent of the project. Refer to pollution control equipment, and expected improvements in source performance as a result of installation. State whether the project will result in full compliance. Attach additional sheet if necessary.

Perform test burn program of Orimulsion fuel. See Attachment A for further information.

B. Schedule of project covered in this application (Construction Permit Application Only)  
Start of Construction<sup>b</sup> July 1990 Completion of Construction<sup>b</sup> June 1992

C. Costs of pollution control system(s): (Note: Show breakdown of estimated costs only for individual components/units of the project serving pollution control purposes. Information on actual costs shall be furnished with the application for operation permit.)

Pilot testing of pollution control equipment will be performed. Cost of pilot equipment is estimated at \$800,000. See Attachment A, Section 2.3.

D. Indicate any previous DER permits, orders and notices associated with the emission point, including permit issuance and expiration dates.

A064-132055 Issued 12/16/87 Expires 12/17/92

<sup>b</sup>Actual testing is scheduled to begin in November 1990 and will continue over a period of approximately 18 months. The time scheduled before and after the testing is required for pretest preparation and demobilization, respectively.

Variable

E. Requested permitted equipment operating time: hrs/day \_\_\_\_; days/wk \_\_\_\_; wks/yr \_\_\_\_;  
If power plant, hrs/yr a; if seasonal, describe: a. Up to 120 full-capacity  
equivalent burn days when Orimulsion fuel is fired. Refer to Section 2.5 in  
Attachment A.

F. If this is a new source or major modification, answer the following questions.  
(Yes or No)

1. Is this source in a non-attainment area for a particular pollutant? No  
a. If yes, has "offset" been applied? \_\_\_\_\_  
b. If yes, has "Lowest Achievable Emission Rate" been applied? \_\_\_\_\_  
c. If yes, list non-attainment pollutants. \_\_\_\_\_

2. Does best available control technology (BACT) apply to this source?  
If yes, see Section VI. No- see Attachment B

3. Does the State "Prevention of Significant Deterioration" (PSD) requirement apply to  
this source? If yes, see Sections VI and VII. Yes-Increment Consumption see  
Attachment B

4. Do "Standards of Performance for New Stationary Sources" (NSPS) apply to this  
source? No-see Attachment B

5. Do "National Emission Standards for Hazardous Air Pollutants" (NESHAP) apply to this  
source? No

H. Do "Reasonably Available Control Technology" (RACT) requirements apply to this  
source? No

- a. If yes, for what pollutants? \_\_\_\_\_  
b. If yes, in addition to the information required in this form, any information  
requested in Rule 17-2.650 must be submitted.

Attach all supportive information related to any answer of "Yes". Attach any  
justification for any answer of "No" that might be considered questionable.

SECTION III: AIR POLLUTION SOURCES & CONTROL DEVICES (Other than Incinerators)

A. Raw Materials and Chemicals Used in your Process, if applicable:  
Not Applicable

Description	Contaminants		Utilization Rate - lbs/hr	Relate to Flow Diagram
	Type	% Wt		

B. Process Rate, if applicable: (See Section V, Item 1)

1. Total Process Input Rate (lbs/hr): N/A

2. Product Weight (lbs/hr): N/A

C. Airborne Contaminants Emitted: (Information in this table must be submitted for each emission point, use additional sheets as necessary)

See Attachment A; Tables 3-2, 3-3, and 3-4

Name of Contaminant	Emission <sup>1</sup>		Allowed <sup>2</sup> Emission Rate per Rule 17-2	Allowable <sup>3</sup> Emission lbs/hr	Potential <sup>4</sup> Emission		Relate to Flow Diagram
	Maximum lbs/hr	Actual T/yr			lbs/hr	T/yr	

<sup>1</sup>See Section V, Item 2.

<sup>2</sup>Reference applicable emission standards and units (e.g. Rule 17-2.600(5)(b)2. Table II, E. (1) - 0.1 pounds per million BTU heat input)

<sup>3</sup>Calculated from operating rate and applicable standard.

<sup>4</sup>Emission, if source operated without control (See Section V, Item 3).

D. Control Devices: (See Section V, Item 4)

Name and Type (Model & Serial No.)	Contaminant	Efficiency	Range of Particles Size Collected (in microns) (If applicable)	Basis for Efficiency (Section V Item 5)
Multicyclones	Particulate	30.3%	<5 μm	Eng. Est.

E. Fuels

Type (Be Specific)	Consumption*		Maximum Heat Input (MMBTU/hr)
	avg/hr	max./hr	
Orimulsion	Variable	311,538 lb/hour	4,050

\*Units: Natural Gas--MMCF/hr; Fuel Oils--gallons/hr; Coal, wood, refuse, others--lbs/hr.

Fuel Analysis: No. 6 Fuel oil

Percent Sulfur: 2.8 (maximum) Percent Ash: 0.21

Density: 8.4 lbs/gal Typical Percent Nitrogen: 0.5

Heat Capacity: 13,000 BTU/lb 109,200 BTU/gal

Other Fuel Contaminants (which may cause air pollution): see Section 3.0 in Attachment A

F. If applicable, indicate the percent of fuel used for space heating.

Annual Average N/A Maximum \_\_\_\_\_

G. Indicate liquid or solid wastes generated and method of disposal.

See Section 2.4 of Attachment A.

H. Emission Stack Geometry and Flow Characteristics (Provide data for each stack):

Stack Height: 400 ft. Stack Diameter: 19.2 ft.  
 Gas Flow Rate: 1,275,000 ACFM 769,300 DSCFM Gas Exit Temperature: 313 °F.  
 Water Vapor Content: 12 % Velocity: 73.4 FPS

SECTION IV: INCINERATOR INFORMATION  
 Not Applicable

Type of Waste	Type 0 (Plastics)	Type II (Rubbish)	Type III (Refuse)	Type IV (Garbage)	Type IV (Pathological)	Type V (Liq. & Gas By-prod.)	Type VI (Solid By-prod.)
Actual lb/hr Incinerated							
Uncontrolled (lbs/hr)							

Description of Waste \_\_\_\_\_  
 Total Weight Incinerated (lbs/hr) \_\_\_\_\_ Design Capacity (lbs/hr) \_\_\_\_\_  
 Approximate Number of Hours of Operation per day \_\_\_\_\_ day/wk \_\_\_\_\_ wks/yr. \_\_\_\_\_  
 Manufacturer \_\_\_\_\_  
 Date Constructed \_\_\_\_\_ Model No. \_\_\_\_\_

	Volume (ft) <sup>3</sup>	Heat Release (BTU/hr)	Fuel		Temperature (°F)
			Type	BTU/hr	
Primary Chamber					
Secondary Chamber					

Stack Height: \_\_\_\_\_ ft. Stack Diameter: \_\_\_\_\_ Stack Temp. \_\_\_\_\_  
 Gas Flow Rate: \_\_\_\_\_ ACFM \_\_\_\_\_ DSCFM\* Velocity: \_\_\_\_\_ FPS

\*If 50 or more tons per day design capacity, submit the emissions rate in grains per standard cubic foot dry gas corrected to 50% excess air.

Type of pollution control devices:  Cyclone  Wet Scrubber  Afterburner  
 Other (specify) \_\_\_\_\_

Brief description of operating characteristics of control devices: \_\_\_\_\_

Ultimate disposal of any effluent other than that emitted from the stack (scrubber water, ash, etc.):

NOTE: Items 2, 3, 4, 6, 7, 8, and 10 in Section V must be included where applicable.

### SECTION V: SUPPLEMENTAL REQUIREMENTS

Please provide the following supplements where required for this application.

1. Total process input rate and product weight -- show derivation [Rule 17-2.100(127)]  
Not Applicable
2. To a construction application, attach basis of emission estimate (e.g., design calculations, design drawings, pertinent manufacturer's test data, etc.) and attach proposed methods (e.g., FR Part 60 Methods, 1, 2, 3, 4, 5) to show proof of compliance with applicable standards. To an operation application, attach test results or methods used to show proof of compliance. Information provided when applying for an operation permit from a construction permit shall be indicative of the time at which the test was made.  
See Attachment A
3. Attach basis of potential discharge (e.g., emission factor, that is, AP42 test).  
See Attachment A
4. With construction permit application, include design details for all air pollution control systems (e.g., for baghouse include cloth to air ratio; for scrubber include cross-section sketch, design pressure drop, etc.)  
Pilot testing will be performed; see Section 2.3 of Attachment A
5. With construction permit application, attach derivation of control device(s) efficiency. Include test or design data. Items 2, 3 and 5 should be consistent: actual emissions - potential (1-efficiency). Not Applicable
6. An 8 ½" x 11" flow diagram which will, without revealing trade secrets, identify the individual operations and/or processes. Indicate where raw materials enter, where solid and liquid waste exit, where gaseous emissions and/or airborne particles are evolved and where finished products are obtained. See Attachment A, Figure 2-1.
7. An 8 ½" x 11" plot plan showing the location of the establishment, and points of airborne emissions, in relation to the surrounding area, residences and other permanent structures and roadways (Examples: Copy of relevant portion of USGS topographic map).  
See Attachment C; Figure C-1
8. An 8 ½" x 11" plot plan of facility showing the location of manufacturing processes and outlets for airborne emissions. Relate all flows to the flow diagram.  
See Attachment C; Figure C-1

- 9. The appropriate application fee in accordance with Rule 17.4.05. The check should be made payable to the Department of Environmental Regulation. Check Attached
- 10. With an application for operation permit, attach a Certificate of Completion of Construction indicating that the source was constructed as shown in the construction permit. Not Applicable

**SECTION VI: BEST AVAILABLE CONTROL TECHNOLOGY**  
Not Applicable

A. Are standards of performance for new stationary sources pursuant to 40 C.F.R. Part 60 applicable to the source?

Yes    No

Contaminant	Rate or Concentration

B. Has EPA declared the best available control technology for this class of sources (If yes, attach copy)

Yes    No

Contaminant	Rate or Concentration

C. What emission levels do you propose as best available control technology?

Contaminant	Rate or Concentration

D. Describe the existing control and treatment technology (if any).

- |                           |                          |
|---------------------------|--------------------------|
| 1. Control Device/System: | 2. Operating Principles: |
| 3. Efficiency:*           | 4. Capital Costs:        |

\*Explain method of determining



5. Useful Life:

6. Operating Costs:

7. Energy:

8. Maintenance Cost:

9. Emissions:

Contaminant

Rate or Concentration

Contaminant	Rate or Concentration

10. Stack Parameters

a. Height: ft.

b. Diameter ft.

c. Flow Rate: ACFM

d. Temperature: °F.

e. Velocity: FPS

E. Describe the control and treatment technology available (As many types as applicable, use additional pages if necessary).

1.

a. Control Devices:

b. Operating Principles:

c. Efficiency:<sup>1</sup>

d. Capital Cost:

e. Useful Life:

f. Operating Cost:

g. Energy:<sup>2</sup>

h. Maintenance Cost:

i. Availability of construction materials and process chemicals:

j. Applicability to manufacturing processes:

k. Ability to construct with control device, install in available space, and operate within proposed levels:

2.

a. Control Device:

b. Operating Principles:

c. Efficiency:<sup>1</sup>

d. Capital Cost:

e. Useful Life:

f. Operating Cost:

g. Energy:<sup>2</sup>

h. Maintenance Cost:

i. Availability of construction materials and process chemicals:

<sup>1</sup>Explain method of determining efficiency.

<sup>2</sup>Energy to be reported in units of electrical power - KWH design rate.

- j. Applicability to manufacturing processes:
  - k. Ability to construct with control device, install in available space, and operate within proposed levels:
- 3.
- a. Control Device:
  - b. Operating Principles:
  - c. Efficiency:<sup>1</sup>
  - d. Capital Cost:
  - e. Useful Life:
  - f. Operating Cost:
  - g. Energy:<sup>2</sup>
  - h. Maintenance Cost:
  - i. Availability of construction materials and process chemicals:
  - j. Applicability to manufacturing processes:
  - k. Ability to construct with control device, install in available space, and operate within proposed levels:
- 4.
- a. Control Device:
  - b. Operating Principles:
  - c. Efficiency:<sup>1</sup>
  - d. Capital Cost:
  - e. Useful Life:
  - f. Operating Cost:
  - g. Energy:<sup>2</sup>
  - h. Maintenance Cost:
  - i. Availability of construction materials and process chemicals:
  - j. Applicability to manufacturing processes:
  - k. Ability to construct with control device, install in available space, and operate within proposed levels:

F. Describe the control technology selected:

- 1. Control Device:
- 2. Efficiency:<sup>1</sup>
- 3. Capital Cost:
- 4. Useful Life:
- 5. Operating Cost:
- 6. Energy:<sup>2</sup>
- 7. Maintenance Cost:
- 8. Manufacturer:
- 9. Other locations where employed on similar processes:
- a. (1) Company:
- (2) Mailing Address:
- (3) City:
- (4) State:

<sup>1</sup>Explain method of determining efficiency.

<sup>2</sup>Energy to be reported in units of electrical power - KWH design rate.

- (5) Environmental Manager:
- (6) Telephone No.:
- (7) Emissions:<sup>1</sup>

Contaminant	Rate or Concentration

(8) Process Rate:<sup>1</sup>

- b. (1) Company:
- (2) Mailing Address:
- (3) City: (4) State:
- (5) Environmental Manager:
- (6) Telephone No.:
- (7) Emissions:<sup>1</sup>

Contaminant	Rate or Concentration

(8) Process Rate:<sup>1</sup>

10. Reason for selection and description of systems:

<sup>1</sup>Applicant must provide this information when available. Should this information not be available, applicant must state the reason(s) why.

**SECTION VII - PREVENTION OF SIGNIFICANT DETERIORATION**  
See Attachment D

A. Company Monitored Data

1. \_\_\_\_\_ no. sites \_\_\_\_\_ TSP \_\_\_\_\_ ( ) SO<sup>2\*</sup> \_\_\_\_\_ Wind spd/dir

Period of Monitoring \_\_\_\_\_ / \_\_\_\_\_ / \_\_\_\_\_ to \_\_\_\_\_ / \_\_\_\_\_ / \_\_\_\_\_  
month day year month day year

Other data recorded \_\_\_\_\_

Attach all data or statistical summaries to this application.

\*Specify bubbler (B) or continuous (C).

2. Instrumentation, Field and Laboratory

- a. Was instrumentation EPA referenced or its equivalent?  Yes  No
- b. Was instrumentation calibrated in accordance with Department procedures?  
 Yes  No  Unknown

B. Meteorological Data Used for Air Quality Modeling

- 1. \_\_\_\_\_ Year(s) of data from \_\_\_\_\_ / \_\_\_\_\_ / \_\_\_\_\_ to \_\_\_\_\_ / \_\_\_\_\_ / \_\_\_\_\_  
month day year month day year
- 2. Surface data obtained from (location) \_\_\_\_\_
- 3. Upper air (mixing height) data obtained from (location) \_\_\_\_\_
- 4. Stability wind rose (STAR) data obtained from (location) \_\_\_\_\_

C. Computer Models Used

- 1. \_\_\_\_\_ Modified? If yes, attach description.
- 2. \_\_\_\_\_ Modified? If yes, attach description.
- 3. \_\_\_\_\_ Modified? If yes, attach description.
- 4. \_\_\_\_\_ Modified? If yes, attach description.

Attach copies of all final model runs showing input data, receptor locations, and principle output tables.

D. Applicants Maximum Allowable Emission Data

Pollutant	Emission Rate
TSP	_____ grams/sec
SO <sup>2</sup>	_____ grams/sec

E. Emission Data Used in Modeling

Attach list of emission sources. Emission data required is source name, description of point source (on NEDS point number), UTM coordinates, stack data, allowable emissions, and normal operating time.

F. Attach all other information supportive to the PSD review.

G. Discuss the social and economic impact of the selected technology versus other applicable technologies (i.e, jobs, payroll, production, taxes, energy, etc.). Include assessment of the environmental impact of the sources.

H. Attach scientific, engineering, and technical material, reports, publications, journals, and other competent relevant information describing the theory and application of the requested best available control technology.

**ATTACHMENT A**

**DESCRIPTION OF ORIMULSION™  
TEST BURN AT  
FPL SANFORD UNIT 4**

**PREPARED FOR:**

**Florida Power & Light Company  
West Palm Beach, Florida**

**PREPARED BY:**

**KBN Engineering and Applied Sciences, Inc.  
1034 NW 57th Street  
Gainesville, Florida 32605**

**April 1990  
89041B1**

TABLE OF CONTENTS

LIST OF TABLES	ii
LIST OF FIGURES	ii
1.0 INTRODUCTION	1-1
2.0 TEST BURN PROGRAM	2-1
2.1 <u>OBJECTIVES</u>	2-1
2.2 <u>TEST PLAN</u>	2-1
2.3 <u>EMISSION CONTROLS PILOT TESTING</u>	2-6
2.4 <u>PILOT TESTING SOLID WASTE MANAGEMENT</u>	2-8
2.5 <u>SCHEDULE</u>	2-9
2.6 <u>EQUIPMENT MODIFICATIONS AND OPERATION</u>	2-12
2.6.1 FUEL HANDLING	2-12
2.6.2 BOILER AUXILIARIES	2-12
2.6.3 BALANCE OF PLANT	2-14
3.0 ESTIMATED EMISSIONS	3-1
3.1 <u>REGULATED POLLUTANTS</u>	3-1
3.2 <u>NON-REGULATED POLLUTANTS</u>	3-6
4.0 EMISSIONS TESTING PROTOCOL	4-1
REFERENCES	

LIST OF TABLES

1-1	Characteristics of Residual Oil and Orimulsion	1-2
2-1	Equipment Requirements for Orimulsion Test Burn	2-13
3-1	Comparison of Orimulsion With Other Fuels Burned At The FPL Sanford Plant	3-2
3-2	Maximum Estimated Emissions for Existing and Orimulsion Test Burn at FPL's Sanford Plant	3-3
3-3	Orimulsion and Residual Oil Emission Factors and Estimates for Lead, Arsenic, Beryllium and Mercury	3-7
3-4	Orimulsion and Residual Oil Emission Factors and Estimates for Selected Non-Regulated Pollutants	3-8
4-1	Emissions Testing Protocol for Orimulsion Test Burn at FPL Sanford Unit 4	4-2

LIST OF FIGURES

2-1	Flue Gas Schematic	2-5
2-2	Test Burn Schedule	2-10



## 1.0 INTRODUCTION

Very large deposits of heavy bitumen, from which emulsified fuels can be developed, have been identified in the Orinoco River area of Venezuela. The national petroleum company, Petroleos de Venezuela, South America, has sponsored the development and demonstration of a technology for the preparation of an emulsion of bitumen in water, known as Orimulsion. Orimulsion consists of an emulsion of about 71 percent bitumen in 29 percent water. Small amounts of an emulsifying agent and a water-soluble magnesium complex are added during the preparation process. Orimulsion has a heating value of approximately 13,000 British thermal units per pound (Btu/lb). The fuel contains up to about 2.8 percent sulfur and 0.2 percent ash (see Table 1-1). Orimulsion is stable at temperatures up to 180°F, but becomes unstable at higher temperatures; therefore, the fuel must be stored at temperatures below about 160°F. Good atomization has been achieved at this temperature using steam as the atomizing agent. Orimulsion can be handled and burned in utility boilers for power generation. Tests in pilot-scale furnaces were followed in July 1988 by a successful long-term demonstration program in the 100-megawatt (MW) corner-fired Dalhousie Generating Station Unit 1 in New Brunswick, Canada. At Dalhousie, 137,500 tons of Orimulsion has been burned, generating approximately 335,000 megawatt hours (MWh) of electricity.

FPL is seeking approval from the Florida Department of Environmental Regulation (FDER) to do a full-scale test burn of Orimulsion at its Sanford Unit 4. This approval involves a petition under Chapter 17-103.120 F.A.C. This attachment to the petition presents the test plan, estimated emissions from Orimulsion, and emissions testing protocol for the test burn.

Table 1-1. Characteristics of Residual Oil and Orimulsion

Parameter	Unit	Current No. 6 Fuel Oil	Orimulsion
Heat of Combustion (HHV)	Btu/lb	18,200	13,000
Sulfur Content	Percent weight	1.5 to 2.0	2.6 to 2.8
Nitrogen Content	Percent weight	0.35	0.5
Ash Content	Percent weight	0.03	0.20
Water Content	Percent weight	<2	28.5

## 2.0 TEST BURN PROGRAM

### 2.1 OBJECTIVES

To date, the testing of Orimulsion fuel has been conducted in pilot installations and in the 100-MW Dalhousie Unit No. 1 in New Brunswick, Canada. Tests indicate that Orimulsion fuel has the potential to displace No. 6 fuel oil in steam electric power plants.

The main objectives of the test burn at Sanford Unit 4 are to demonstrate the practicality of firing Orimulsion fuel in a large, front wall-fired utility boiler to evaluate the performance of air emissions control equipment, and to generate a technical database for the engineering and design of the potential future conversion to Orimulsion of the Sanford plant and several other large generating units in FPL's system.

Test burning of Orimulsion at Sanford Unit 4 will provide the opportunity to evaluate the technical and operational features under utility operating conditions. Various technical uncertainties will be clarified or resolved during this test burn period. Fuel handling, storage and combustion, properties of the flue gas, removal efficiency of gaseous and particulate pollution control devices, solid waste handling and disposal, and equipment performance and operating characteristics will be tested and evaluated. The knowledge and experience gained during the test burn will assess the feasibility of full conversion to be assessed.

### 2.2 TEST PLAN

A preliminary test plan has been developed which defines the activities and identifies the resource requirements for the test burn. The test burn will be carried out in four phases:

1. Startup tests,
2. Initial characterization tests,
3. Operational tests, and
4. Structured performance tests.

Startup Tests--Startup tests would be performed to verify that all new or refurbished equipment has been properly installed and operates as required. The work during the startup tests would be similar to that on conventional projects. These tests will identify early potential problems and assure satisfactory operation during the other test phases.

Initial Characterization Tests--Initial characterization tests will be the first series of tests involving the firing of Orimulsion. The purpose of this test is to establish equipment limitations and operating procedures while using this fuel. These tests will also familiarize plant personnel with Orimulsion firing and serve as an operational training program.

Initial characterization tests will focus on boiler performance. The testing will begin by firing Orimulsion in a few burners; additional burners firing Orimulsion will gradually be added. Temperature measurements will be taken to set the maximum and minimum load limits of the unit. Measurements and analyses will be performed to establish optimal levels of operating parameters (e.g., excess air levels, fuel heating requirements, atomizing steam pressure, soot-blowing schedule, etc.) to be used during the test burn program.

Initial characterization tests will also involve further assessments of the fuel storage and handling systems inspected during the startup tests. Key parameters to be evaluated include storage tank settlement and fuel-handling system pressure drops, product stability, and heating system performance. These tests would be initiated with startup testing. Storage tank settlement will be evaluated as soon as the tank is filled with Orimulsion. This testing will provide a basis for establishing the need of mixing and the schedule to be followed throughout the test burn program. Fuel samples will be taken from various locations in the tanks over a period of several weeks and at different locations in the fuel-handling system.

Operational Tests--Operational testing will be performed to determine the effects of continuous firing of Orimulsion. The boiler will be fired continuously on Orimulsion fuel for up to 24 hours each day during the test period except for scheduled shutdowns or when system dispatch dictates switching back to fuel oil. System dispatch requirements will dictate the operating load levels for the unit. The operational tests will be used to evaluate:

1. Ash accumulations and locations,
2. Soot blower effectiveness,
3. Combustion patterns and efficiency,
4. Operating difficulties,
5. Maintenance requirements,
6. Causes of forced outages, and
7. Low-temperature corrosion.

Orimulsion stability and settlement throughout the fuel-handling system will also be determined. Maintenance logs developed during the test burn program will be used to evaluate the effect of Orimulsion firing on plant availability and on operation and maintenance costs. Equipment failure rates reported during the test will be compared to those observed when firing oil.

The flue gas cleanup equipment (desulfurization and particulate matter removal) will contribute the most cost in full conversion to Orimulsion. However, there currently are significant uncertainties in the design of such equipment for Orimulsion applications. The solid waste products and particle size distribution resulting from combustion are expected to differ from those resulting from burning No. 6 fuel oil. The ability to remove sulfur dioxide (SO<sub>2</sub>) from Orimulsion flue gases is also not well documented. Therefore, extensive pilot testing will have to be performed. The plan calls for temporary installation of small, self-contained pilot plants for several emissions control technologies, including electrostatic precipitator, a lime spray dryer, and different fabric filter designs. The pilot plants will be connected via a slip-stream duct parallel to the

existing flue-gas ductwork (Figure 2-1). Flue gas from the particulate control devices will be further characterized for design of wet scrubber or regenerable process equipment. Emission measurements will be taken to understand and quantify the equipment's operating performance (refer to Section 4.0).

Structured Performance Tests--The structured performance tests are designed to determine the performance of specific systems under controlled conditions. Two structured test series are planned on oil: the first during the startup test period, i.e., before firing any Orimulsion, and the second after completion of the Orimulsion test burn. Four structured performance tests are planned on Orimulsion. Boiler testing will be conducted during each series, and balance of plant (i.e., fuel-handling and storage equipment and air pollution control equipment) testing will be performed twice.

The structured boiler performance tests are designed to establish performance differences between Orimulsion and oil firing and to obtain basic boiler design information for application to a conversion at Sanford and other units. Performing tests on both oil and Orimulsion will also provide an opportunity to gather data regarding slagging and fouling characteristics for firing both fuels.

The structured performance tests on oil will be performed at four distinct plant loads (25-, 50-, 75-, and 100-percent loads). These tests will be used to characterize unit performance with oil firing over the unit's entire load range after modification. The structured performance tests on Orimulsion will be at the same four plant loads.

Performance characterization of the boiler during the structured test series will include boiler gross efficiency, combustion efficiency, stack emission rates, ash and slag characterization, burner and flame documentation, and boiler metal temperatures at strategically selected detection points.

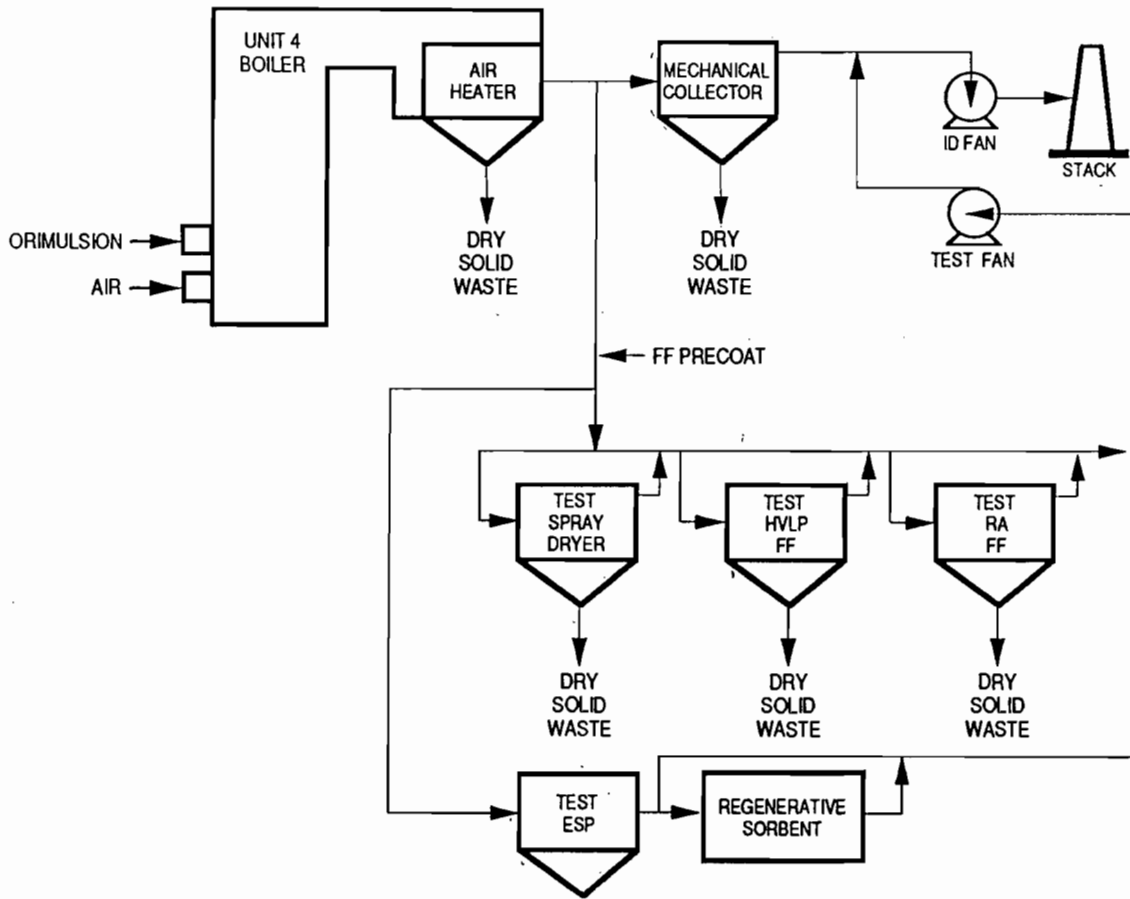

**SANFORD PLANT ORIMULSION TEST BURN  
Pilot - Scale Emissions Control Equipment Testing**

Flue gases diverted to side stream (5,000 acfm) to evaluate:

1. Three particulate control technologies for possible future use upstream of a wet scrubber or regenerable sorbent FGD system:
  - (a) Electrostatic Precipitator (ESP)
  - (b) Reverse Air Fabric Filter (RA - FF)
  - (c) High - Volume - Low - Pressure Pulse Jet Fabric Filter (HVLP - FF)
2. Lime Spray Dryer (FGD) in combination with the Reverse - Air or Pulse Jet Fabric Filters.

Figure 2-1 FLUE GAS SCHEMATIC



Balance of plant areas which will be tested include plant cycle efficiency, mechanical collector performance, pilot precipitator performance, ash properties relevant to ash disposal, and pilot spray dryer and fabric filter performance. These tests will be scheduled simultaneously with boiler performance tests since much data will be common to both. The first set of plant performance tests will be on oil to establish baselines for comparison. Two of the balance of plant test series will be on Orimulsion, one series early in the test burn period and the other near the end.

To evaluate the impact of Orimulsion conversion on overall plant efficiency, the following parameters will be measured: net plant heat rate, turbine cycle efficiency, boiler efficiency, and auxiliary power consumption.

### 2.3 EMISSION CONTROLS PILOT TESTING

An emissions control system will be proposed for SO<sub>2</sub> and particulate matter emissions for full-scale Orimulsion conversions.

Flue gas desulfurization (FGD) systems with relatively high SO<sub>2</sub> removal efficiencies are currently available. These technologies, which are calcium based and use wet or dry scrubbing, are characterized by high investment costs. Lower cost technologies are being developed for applications that require less stringent SO<sub>2</sub> removal. These emerging controls involve dry injection processes which introduce sorbent into either the furnace or post-furnace regions (i.e., in-duct injection).

Particulate control technologies considered feasible for Orimulsion are fabric filters and electrostatic precipitators (ESP). The ash and gases produced by Orimulsion firing are expected to be similar to oil firing in many respects. However, there is limited utility experience with fabric filters used on oil-fired units and virtually no experience on fabric filters with Orimulsion fuel.



Pilot scale testing of fabric filters will be performed during the Orimulsion test burn at Sanford 4 to collect design operating data. Two types of fabric filters will be investigated for Sanford, the reverse-air type and the pulse-jet type (low, intermediate, and high pressure).

Several desulfurization methods are feasible for Orimulsion firing, including spray dryer, in-duct injection and wet scrubbing. Each has different particulate removal requirements. Spray drying will produce higher solids loading and will require greater capacity for particulate removal. The wet-scrubbing alternative could require the highest particulate removal efficiency.

The dust loading produced by dry scrubbers will require a high removal efficiency. Fabric filters are the preferred method of particulate control for this alternative. There is good fabric filter operating experience collecting sulfur containing solids and unreacted reagent from fluid-bed boilers and from coal-fired dry-scrubbing applications. The particulates form a cake on the fabric surface that is fairly easy to remove. A fabric filter improves SO<sub>2</sub> removal by extending the contact between reagent and gas. Gases leaving a dry scrubber will be relatively cool so it will be possible to use less expensive fabric as the filtering medium.

For the wet-scrubbing alternative, the particulate collector will be located upstream of the FGD system. ESPs have been used in these applications due to the higher particulate removal requirements and higher temperatures. However, ESP experience in an Orimulsion application is limited, and a pilot ESP facility will therefore be included in the test burn. Characterization of the gas stream from the pilot-scale ESP will furnish the necessary design data for a wet scrubber system, as well as for a possible regenerable sorbent system.

#### 2.4 PILOT TESTING SOLID WASTE MANAGEMENT

The Sanford Unit 4 Orimulsion test burn will also provide the raw data necessary to meet the following important objectives relating to solid waste handling:

1. Characterization of the chemical and physical properties of the solid wastes for use as input in the design of full-scale waste handling systems.
2. Evaluation of the methods and equipment used to manage the solid wastes during the test burn.

Two types of solid waste will be generated during the test burn--Orimulsion fly ash and lime spray dryer solid waste. The spray dryer waste will be composed of the fly ash mixed together with calcium sulfite, calcium sulfate, and unreacted lime.

A vacuum, dilute pneumatic system will be utilized during the test burn to transfer solid waste from the particulate collectors (pilot-scale fabric filters and electrostatic precipitator) and the spray dryer to a temporary storage silo. Samples of the ash from the particulate collectors will be analyzed to determine metals content for possible sale of recovered metals. Samples of the spray dryer waste will be studied for stability as part of an ongoing laboratory analysis program sponsored by FPL in cooperation with the Florida Institute of Technology.

Due to the small volume of solid waste generated during the test, wastes may be transported off-site for ultimate disposal at a facility acceptable to FDER. The quantity of fly ash that will be generated is estimated at approximately 3,600 lb. Total waste generated from the spray dryer will be about 16,000 lb.

A second alternative for management of test burn solid wastes is disposal on-site utilizing a landfill with an impermeable liner. This approach would involve a relatively small area, approximately 10 feet (ft) x 10 ft x 5 ft high. Provision would be made for groundwater monitoring and leachate

control, with routing of runoff to the existing plant ash settling basins. The on-site disposal alternative would be equivalent to a "test-cell" and could be used to evaluate landfill design prior to planning for a permanent conversion.

Neither of these alternatives for the test burn would necessitate a change to the power plant's existing state and federal wastewater permit discharge limits.

## 2.5 SCHEDULE

Figure 2-2 presents a conceptual testing schedule. The actual schedule of testing will probably be affected by early test results, unit reliability, system power requirements, etc. The test program is assumed to start in November or December 1990. Startup tests will proceed parallel with the final phases of construction. Initial startup after the modifications will be on oil. Boiler and balance of plant performance will be tested to develop baseline operations.

The period of oil-fired testing will be followed by initial firing of Orimulsion fuel and initial characterization tests. During this period, optimum settings will be determined, and the plant staff will become familiar with Orimulsion operation. The minimum and maximum limits of Orimulsion firing as a function of unit output and load change rates will be investigated.

After stable operation on Orimulsion has been achieved, boiler and balance of plant structured testing will be performed. This test series will measure Orimulsion performance in a relatively clean boiler. An outage will be scheduled after this test series on Orimulsion to allow inspection, adjustment, or repair of plant components, test equipment, and instruments.

Periods of sustained low load and high load operation will be scheduled early in the test program to identify operating problems before the unit has to be restored to commercial operation. Outages after each period will

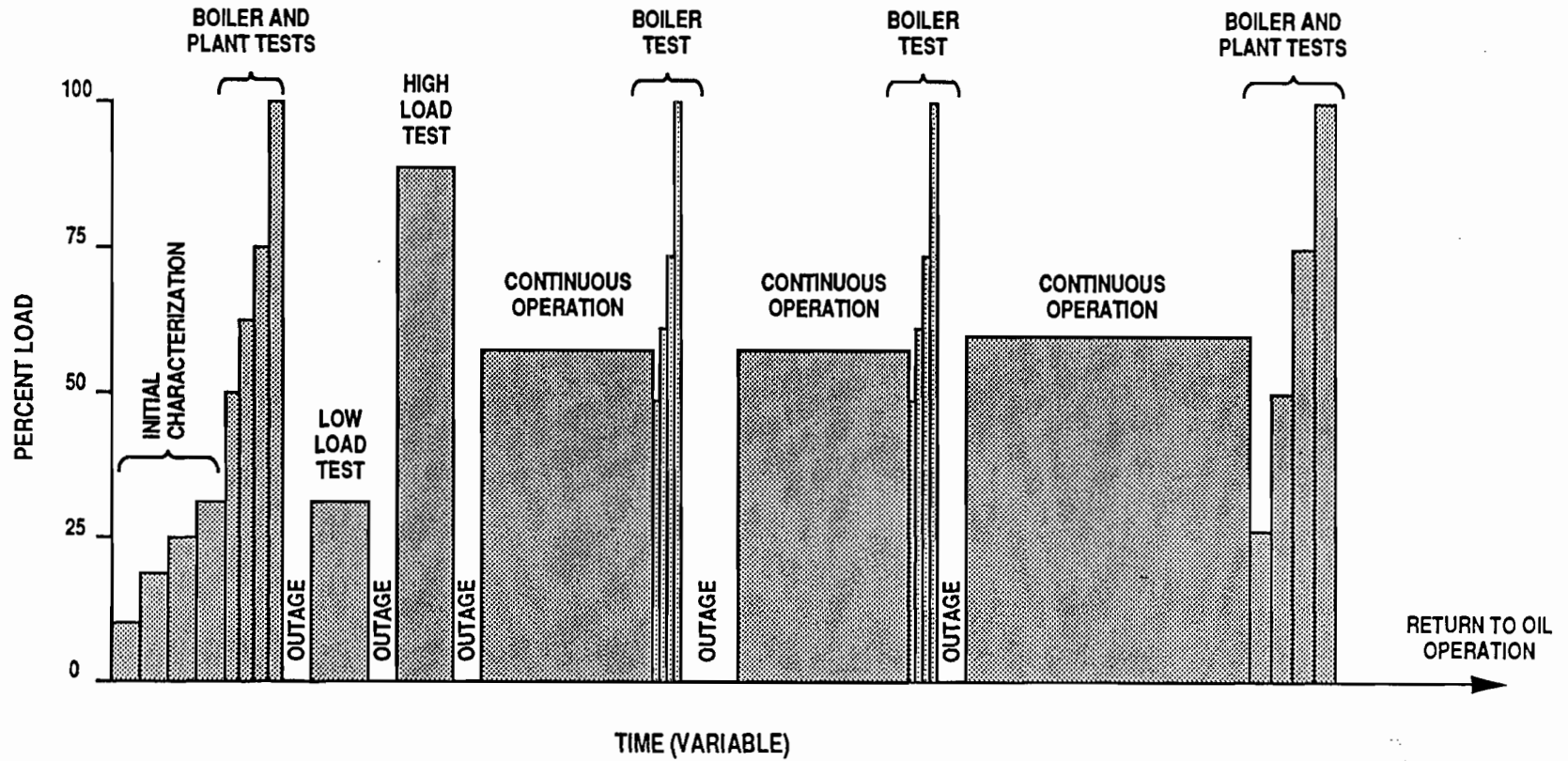

NOTE: TOTAL TEST WOULD TAKE FROM 1 TO 1.5 YEARS TO ACHIEVE 120 FULL-POWER DAYS.

2-10

Figure 2-2 TEST BURN SCHEDULE



permit inspection of the boiler for fouling, plugging or slag buildup, and for adjustments or repairs if required.

For three longer periods of the test program, the unit will operate under the normal dispatch mode. Each period will be followed by a boiler performance test and an outage. This will permit detection of changes in unit performance with time, as well as allow equipment adjustments or repairs.

Operation of pilot-scale flue gas desulfurization and particulate control equipment will be scheduled after stable and reliable plant operation has been established.

A series of complete plant tests are scheduled after the final period of Orimulsion firing. These tests will provide data on Orimulsion performance after continuous use under normal operating conditions. These tests will also incorporate all adjustments to plant operations as well as modifications to the equipment and fuel composition.

The final outage will be longer than the other scheduled outages to allow dismantling of test equipment and restoration of the unit to the pretest conditions.

After all Orimulsion data is taken, oil firing will resume. Plant performance on oil will be measured shortly after resumption of oil firing to determine any changes caused by continuous Orimulsion firing.

The test plan will provide over 2,000 hours (up to 120 days) of full-power equivalent of Orimulsion-fired operation. (A full power hour is defined as the maximum heat input to Unit 4 for one hour, which is  $4,050 \times 10^8$  Btu; 120 full power days is the equivalent of  $11.66 \times 10^{12}$  Btu heat input.) This is believed to be adequate for collection of needed design data.

## 2.6 EQUIPMENT MODIFICATIONS AND OPERATION

Due to the temporary nature of the test burn program, equipment modifications will be kept to a minimum, but will be consistent with the need to gather performance and operating data for the design of a full conversion to Orimulsion firing. New equipment and existing equipment that will be provided or refurbished for use with Orimulsion during the test burn is listed in Table 2-1 and discussed in the following sections.

### 2.6.1 FUEL HANDLING

No. 6 fuel oil currently is heated with steam for both bulk storage and burner feed heating. To assure that Orimulsion is kept below its maximum storage temperature of 180°F, some heat exchange equipment will be added. A fuel flow meter will be added to assure accurate recording of Orimulsion use.

The hot water heat exchanger and associated equipment is being added to the existing tanks instead of submerged direct heaters to assure a uniform temperature of 100°F for the Orimulsion. These heaters also will serve as the primary heaters for Orimulsion firing.

For Orimulsion storage, two existing tanks (C and D) will be used. These tanks will be inspected and insulation will be added to assure that a temperature of 100°F is maintained. Vertical mixers in Storage Tank C will be inspected to assure operation. Tank D does not have mixers. Having one tank with and one tank without mixers will allow an evaluation of long-term storage on Orimulsion properties, e.g., settling and separation.

The existing burner feed pumps will be fitted with variable speed drives to accurately match pump flow rates to burner requirements.

### 2.6.2 BOILER AUXILIARIES

Burner guns and tips will be added to allow steam atomizing during Orimulsion firing. The steam atomization system will use the existing

Table 2-1. Equipment Requirements for Orimulsion Test Burn

System	New	Inspect/Adjust/ Refurbish
Fuel Handling	Hot water heat exchangers (heat tracing and burner supply heating), circulating hot water pumps, hot water surge tank  Orimulsion fuel flow meter	Storage tanks C & D (condition assessment, insulation)  Burner feed pumps  Tank C vertical mixers (axial flow blades)
Boiler Auxiliaries	Burner guns and tips (steam atomization)	Furnace wall blowers
Balance of Plant	Emission testing related flue-gas ductwork (sidestream--air emission testing)  Pilot plants for rotary atomized lime spray dryer, regenerable absorber, reverse air fabric filter, pulse jet fabric filter (low, intermediate, and high pressure), and electrostatic precipitator  Test fan	

plant auxiliary steam system and the existing fuel oil return piping. No. 6 fuel oil will be fired using steam atomization.

Furnace wall blowers, which were used during the coal-oil mixture (COM) testing, will be used during the test burn.

### 2.6.3 BALANCE OF PLANT

Duct work related to the flue gas testing will be added to provide a side stream for the pilot plants. The pilot plants (see Figure 2-1) will use about 5,000 acfm for testing removal efficiencies of particulate matter and SO<sub>2</sub>.



### 3.0 ESTIMATED EMISSIONS

#### 3.1 REGULATED POLLUTANTS

The characteristics of Orimulsion compared with other fuels burned (either alone or in combination with other fuels) at the Sanford Plant are presented in Table 3-1. Currently, a medium sulfur (i.e., between 1.0 and 2.0 percent) residual fuel oil is burned at the plant, which results in maximum PM and SO<sub>2</sub> emissions of 0.1 and 1.65 to 2.25 lb/million Btu heat input, respectively. Higher sulfur (i.e., 2.5 percent) residual fuel oil and COM have been previously burned; the highest PM and SO<sub>2</sub> emissions using these fuels were 0.7 and 2.75 lb/million Btu heat input, respectively. The 2.5 percent sulfur residual oil represents the maximum permitted SO<sub>2</sub> emission rate.

It is anticipated that test burning of Orimulsion will result in temporarily increased PM and SO<sub>2</sub> emissions for the Sanford Unit 4 over currently occurring or permitted levels. Table 3-2 presents the maximum expected emissions for all regulated pollutants during the test burn and those requiring approval by the FDER. Annual emissions are based on 120 days of operation at full power, i.e., the maximum heat input of  $4,050 \times 10^8$  Btu/hr.

Maximum SO<sub>2</sub> emissions would be 4.3 lb/million Btu heat input based on the worst-case Orimulsion fuel quality. Total SO<sub>2</sub> emissions from the plant will be minimized by using low sulfur (i.e., 1 percent) fuel oil in Units 3 and 5. Emissions of sulfuric acid mist may increase with the increase in SO<sub>2</sub> emissions, although the magnesium present in the fuel could act to prevent or limit any such an increase.

PM and PM<sub>10</sub> emissions are expected to be no greater than 0.3 lb/million Btu heat input during normal Orimulsion firing and 0.6 lb/million Btu heat input during load changes, soot blowing, and variable testing conditions. This would result in a maximum 24 hour average PM/PM<sub>10</sub> emission rate of 0.34 lb/million Btu heat input. The proposed emission

Table 3-1. Comparison of Orimulsion With Other Fuels Burned At The FPL Sanford Plant

Fuel	Medium-S Residual <sup>a</sup>	High-S Residual <sup>b</sup>	Coal <sup>c</sup>	COM <sup>d</sup>	Orimulsion <sup>e</sup>
Sulfur, percent	1.5 - 2.0	2.5	1.5	2.0	2.68
Btu/lb	18,300 typical	18,300 typical	12,500	15,000	13,000
lb SO <sub>2</sub> /10 <sup>6</sup> Btu	1.64 - 2.2	2.75 maximum	2.75 maximum	2.75 maximum	4.14 <sup>f</sup>
Ash, percent	0.10 maximum	0.10 maximum	10.0 maximum	5.0 maximum	0.21 <sup>g</sup>
Vanadium, ppm	200 maximum	500 maximum	NA	NA	322
Particulate, lb/10 <sup>6</sup> Btu	0.10 maximum	0.10 maximum	1.43 <sup>h</sup>	0.70 <sup>h</sup>	0.22 <sup>h</sup>

Note: NA = not available.

<sup>a</sup>Fuel oil currently burned at Sanford Plant.

<sup>b</sup>Fuel oil characteristics representative of maximum permitted limits.

<sup>c</sup>Based on 1981 Sanford coal test burn estimates.

<sup>d</sup>Based on 1980 Sanford COM variance estimates or tests for 40 percent coal and 60 percent oil.

<sup>e</sup>Average of four shipments received at Dalhousie, N.B.

<sup>f</sup>Calculated uncontrolled emission rate (per fuel sulfur content).

<sup>g</sup>Includes magnesium-based additive.

<sup>h</sup>Determined uncontrolled particulate emission rate.

Table 3-2. Maximum Estimated Emissions for Existing and Orimulsion Test Burn at FPL's Sanford Plant (Page 1 of 2)

Data	Existing				Orimulsion Testing				Potential Increase
	Unit 3	Unit 4	Unit 5	Total	Unit 3	Unit 4	Unit 5	Total	
Heat Input (10 <sup>6</sup> Btu/hr)	1,650	4,050	4,050		1,650	4,050	4,050		
Sulfur Dioxide									
Emissions Basis	Actual <sup>a</sup>	Actual <sup>a</sup>	Actual <sup>a</sup>		Actual <sup>a</sup>	Actual <sup>b</sup>	Actual <sup>a</sup>		
Emissions Basis (lb/10 <sup>6</sup> Btu)	1.65	1.65	1.65		1.1	4.3	1.1		
Emissions (lb/hour)	2,723	6,683	6,683	16,088	1,815	17,415	4,455	23,685	7,598
Emissions (tons/year) <sup>c</sup>	3,920	9,623	9,623	23,166	2,614	25,078	6,415	34,106	10,940
Particulate Matter									
Emissions Basis	Actual <sup>d</sup>	Actual <sup>d</sup>	Actual <sup>d</sup>		Actual <sup>d</sup>	Actual <sup>e</sup>	Actual <sup>d</sup>		
Emissions Basis (lb/10 <sup>6</sup> Btu)	0.125	0.125	0.125		0.125	0.338	0.125		
Emissions (lb/hour)	206	506	506	1,219	206	1,369	506	2,081	863
Emissions (tons/year) <sup>c</sup>	297	729	729	1,755	297	1,971	729	2,997	1,242
Particulate Matter (PM10)									
Emissions Basis	AP-42 <sup>f</sup>	AP-42 <sup>f</sup>	AP-42 <sup>f</sup>		AP-42 <sup>f</sup>	PM=PM10	AP-42 <sup>f</sup>		
Emissions Basis (lb/10 <sup>6</sup> Btu)	0.09	0.09	0.09		0.09	0.338	0.09		
Emissions (lb/hour)	146	359	359	865	146	1,369	359	1,875	1,009
Emissions (tons/year) <sup>c</sup>	211	518	518	1,246	211	1,971	518	2,700	1,454
Nitrogen Oxides									
Emissions Basis	AP-42 <sup>g</sup>	AP-42 <sup>g</sup>	AP-42 <sup>g</sup>		AP-42 <sup>g</sup>	AP-42 <sup>g</sup>	AP-42 <sup>g</sup>		
Emissions Basis (lb/10 <sup>6</sup> Btu)	0.70	0.70	0.70	0.81	0.70	0.70	0.70		
Emissions (lb/hour)	1,155	2,834	2,834	6,822	1,155	2,834	2,834	6,822	0
Emissions (tons/year) <sup>c</sup>	1,663	4,081	4,081	9,824	1,663	4,081	4,081	9,824	0
Carbon Monoxide									
Emissions Basis	AP-42	AP-42	AP-42		AP-42	AP-42	AP-42		
Emissions Basis (lb/10 <sup>6</sup> Btu)	0.03	0.03	0.03		0.03	0.03	0.03		
Emissions (lb/hour)	55	135	135	325	55	135	135	325	0
Emissions (tons/year) <sup>c</sup>	79	194	194	468	79	194	194	468	0
Volatile Organic Compounds									
Emissions Basis	AP-42	AP-42	AP-42		AP-42	AP-42	AP-42		
Emissions Basis (lb/10 <sup>6</sup> Btu)	0.002	0.002	0.002		0.002	0.002	0.002		
Emissions (lb/hour)	3	8	8	18	3	8	8	18	0
Emissions (tons/year) <sup>c</sup>	4	11	11	26	4	11	11	26	0
Lead									
Emissions Basis	AP-42	AP-42	AP-42		AP-42	AP-42	AP-42		
Emissions Basis (lb/10 <sup>6</sup> Btu)	2.80X10 <sup>-5</sup>	2.80X10 <sup>-5</sup>	2.80X10 <sup>-5</sup>		2.80X10 <sup>-5</sup>	2.80X10 <sup>-5</sup>	2.80X10 <sup>-5</sup>		
Emissions (lb/hour)	0.05	0.11	0.11	0.27	0.05	0.11	0.11	0.27	0
Emissions (tons/year) <sup>c</sup>	0.07	0.16	0.16	0.39	0.07	0.16	0.16	0.39	0
Sulfuric Acid Mist									
Emissions Basis	AP-42	AP-42	AP-42		AP-42	AP-42	AP-42		
Emissions Basis (lb/10 <sup>6</sup> Btu)	2.90X10 <sup>-2</sup>	2.90X10 <sup>-2</sup>	2.90X10 <sup>-2</sup>		1.93X10 <sup>-2</sup>	5.41X10 <sup>-2</sup>	1.93X10 <sup>-2</sup>		
Emissions (lb/hour)	48	117	117	283	32	219	78	329	47
Emissions (tons/year) <sup>c</sup>	69	169	169	407	46	316	113	474	67

3

Table 3-2. Maximum Estimated Emissions for Existing and Orimulsion Test Burn at FPL's Sanford Plant (Page 2 of 2)

Data	Existing				Orimulsion Testing				Potential Increase
	Unit 3	Unit 4	Unit 5	Total	Unit 3	Unit 4	Unit 5	Total	
<b>Total Fluorides</b>									
Emissions Basis	EPA (1987)	EPA (1987)	EPA (1987)		EPA (1981)	EPA (1981)	EPA (1981)		
Emissions Basis (lb/10 <sup>6</sup> Btu)	3.47X10 <sup>-4</sup>	3.47X10 <sup>-4</sup>	3.47X10 <sup>-4</sup>		3.47X10 <sup>-4</sup>	3.47X10 <sup>-4</sup>	3.47X10 <sup>-4</sup>		
Emissions (lb/hour)	0.57	1.40	1.40	3.38	0.57	1.40	1.40	3.38	0.00
Emissions (tons/year) <sup>c</sup>	0.82	2.02	2.02	4.87	0.82	2.02	2.02	4.87	0.00
<b>Mercury</b>									
Emissions Basis	EPA (1989)	EPA (1989)	EPA (1989)		EPA (1989)	EPA (1989)	EPA (1989)		
Emissions Basis (lb/10 <sup>6</sup> Btu)	3.28X10 <sup>-6</sup>	3.28X10 <sup>-6</sup>	3.28X10 <sup>-6</sup>		3.28X10 <sup>-6</sup>	1.54X10 <sup>-5</sup>	3.28X10 <sup>-6</sup>		
Emissions (lb/hour)	5.41X10 <sup>-3</sup>	1.33X10 <sup>-2</sup>	1.33X10 <sup>-2</sup>	0.03	5.41X10 <sup>-3</sup>	6.24X10 <sup>-2</sup>	1.33X10 <sup>-2</sup>	0.08	0.05 <sup>h</sup>
Emissions (tons/year) <sup>c</sup>	0.01	0.02	0.02	0.05	0.01	0.09	0.02	0.12	0.07
<b>Beryllium</b>									
Emissions Basis	EPA (1989)	EPA (1989)	EPA (1989)		EPA (1989)	EPA (1989)	EPA (1989)		
Emissions Basis (lb/10 <sup>6</sup> Btu)	4.37X10 <sup>-6</sup>	4.37X10 <sup>-6</sup>	4.37X10 <sup>-6</sup>		4.37X10 <sup>-6</sup>	1.54X10 <sup>-5</sup>	4.37X10 <sup>-6</sup>		
Emissions (lb/hour)	7.21X10 <sup>-3</sup>	1.77X10 <sup>-2</sup>	1.77X10 <sup>-2</sup>	0.04	7.21X10 <sup>-3</sup>	6.24X10 <sup>-2</sup>	1.77X10 <sup>-2</sup>	0.09	0.04 <sup>h</sup>
Emissions (tons/year) <sup>c</sup>	0.01	0.03	0.03	0.06	0.01	0.09	0.03	0.13	0.06
<b>Arsenic</b>									
Emissions Basis	EPA (1989)	EPA (1989)	EPA (1989)		EPA (1989)	EPA (1989)	EPA (1989)		
Emissions Basis (lb/10 <sup>6</sup> Btu)	4.37X10 <sup>-5</sup>	4.375X10 <sup>-5</sup>	4.37X10 <sup>-5</sup>		4.37X10 <sup>-5</sup>	3.85X10 <sup>-5</sup>	4.37X10 <sup>-5</sup>		
Emissions (lb/hour)	7.21X10 <sup>-2</sup>	1.77X10 <sup>-1</sup>	1.77X10 <sup>-1</sup>	0.43	7.21X10 <sup>-2</sup>	1.56X10 <sup>-1</sup>	1.77X10 <sup>-1</sup>	0.41	-0.02
Emissions (tons/year) <sup>c</sup>	0.10	0.25	0.25	0.61	0.10	0.22	0.25	0.58	-0.03

- Notes: a. 1.5 percent sulfur and 18,200 Btu/lb;  
b. 2.8 percent sulfur and 13,000 Btu/lb;  
c. calculated based on 120 full power days;  
d. based on an average emission of 0.1 lb/10<sup>6</sup> Btu for 21 hours and excess emissions of 0.3 lb/10<sup>6</sup> Btu for 3 hours;  
e. based on an average emission of 0.3 lb/10<sup>6</sup> Btu for 21 hours and excess emissions of 0.6 lb/10<sup>6</sup> Btu for 3 hours;  
f. PM10 emissions is 71 percent of PM emissions (from AP-42);  
g. based on vertical fired boilers, could be as high as 1 lb/10<sup>6</sup> Btu due to low excess air burners; emissions on Orimulsion equivalent to oil firing.  
h. artifact of detection limit; increases not expected;

Emissions of total reduced sulfur, reduced sulfur compounds, hydrogen sulfide, asbestos, vinyl chloride, benzene, and radionuclides are negligible for oil firing.

limit is slightly greater than the uncontrolled emissions observed at the Orimulsion demonstration project at the New Brunswick Power Commission Dalhousie Plant. The uncontrolled steady-state PM emission rate at the 100-MW Dalhousie Unit 1 was 0.22 lb/million Btu heat input. The proposed emission limit reflects potentially higher emissions to account for differences between the Dalhousie unit and the larger 400-MW Sanford Unit 4. The proposed particulate emission limit for the Orimulsion test burn was previously approved by FDER for high sulfur residual oil during the energy emergency of the late 1970s.

PM10 emissions for Orimulsion firing are conservatively assumed to be equivalent to PM emissions. Due to the higher particulate rate and testing uncertainties, the maximum opacity is projected to be 60 percent during steady-state operation, and up to 100 percent is requested during load changes, soot blowing and unsteady/changing conditions caused by testing.

Nitrogen oxide ( $\text{NO}_x$ ) emissions when firing Orimulsion are expected to be similar to firing residual oil.  $\text{NO}_x$  emissions during combustion originate from the oxidation of fuel-bound nitrogen and combustion air nitrogen. The amount of  $\text{NO}_x$  from the oxidation of combustion air nitrogen, so-called thermal  $\text{NO}_x$ , is dependent on flame temperature, excess air level, and flame dynamics. The fuel nitrogen content of Orimulsion is 0.5 percent, which is about 40 percent higher than the residual fuel oil currently being burned. Therefore,  $\text{NO}_x$  emissions from the fuel-bound nitrogen emissions when firing Orimulsion are expected to increase over that of residual fuel oil, all other factors remaining constant. However, experience in firing Orimulsion has indicated that the high moisture content, i.e., about 30 percent, reduces the peak flame temperature and, concomitantly, thermal  $\text{NO}_x$  formation. Results from Dalhousie also indicate lower excess air requirements for Orimulsion combustion. While sufficient data are not currently available to precisely predict  $\text{NO}_x$  emissions when firing Orimulsion, data from the demonstration testing at Dalhousie suggest that total  $\text{NO}_x$

emissions would be about the same for Orimulsion as for fuel oil. As a result, the NO<sub>x</sub> emissions estimates in Table 3-2 are based on similar AP-42 emission factors for both fuels.

Emissions of carbon monoxide (CO) and volatile organic compounds (VOC) were estimated using AP-42 emission factors for residual oil firing for both current residual oil firing and that during the Orimulsion test burn. Combustion characteristics are sufficiently similar for both fuels to conclude that CO emissions will not be significantly different.

For other regulated pollutants, EPA emission factors for residual oil were also used. Emissions data for these pollutants are not available for Orimulsion firing. Laboratory analysis of an Orimulsion fuel sample found that concentrations of arsenic, beryllium, and mercury were below detectable limits (BDL). The reported BDL concentrations are similar to that reported by EPA (see Table 3-3) but suggest increases in mercury and beryllium. However, this result is an artifact of the detection limit and actual increases of these pollutants are not expected.

### 3.2 NON-REGULATED POLLUTANTS

Estimated emissions of nonregulated pollutants during the Orimulsion test burn are presented in Table 3-4. These emissions are based on concentrations of these parameters found from analyzing a sample of Orimulsion fuel. Since all reported values were below the detection limits of the analytical procedure, the emission estimates are conservative. Table 3-4 also presents estimated emissions for residual oil firing that were calculated using EPA emission factors.

Table 3-3. Orimulsion and Residual Oil Emission Factors and Estimates for Lead, Arsenic, Beryllium and Mercury

Pollutant	Orimulsion Sample <sup>a</sup>	Residual Oil				Emissions Increase <sup>c</sup>	
		EPA 1980	EPA 1988	EPA 1989	Maximum <sup>b</sup>	(lb/hr)	(tons/yr)
<b>Lead</b>							
Concentration (ppm)	0.02	3.5	NO	NO	3.5	NO	NO
Emission Factor (lb/10 <sup>6</sup> Btu)	1.54x10 <sup>-6</sup>	1.91x10 <sup>-4</sup>	Emission	Emission	1.91x10 <sup>-4</sup>	Emission	Emission
Unit 4 Emissions (lb/hr) <sup>d</sup>	6.23x10 <sup>-3</sup>	7.75x10 <sup>-1</sup>	Factor	Factor	7.75x10 <sup>-1</sup>	Increase <sup>e</sup>	Increase <sup>e</sup>
<b>Arsenic</b>							
Concentration (ppm)	0.5 DL	0.8	0.36			NO Increase	NO Increase
Emission Factor (lb/10 <sup>6</sup> Btu)	3.85x10 <sup>-5</sup>	4.37x10 <sup>-5</sup>	1.90x10 <sup>-5</sup>	1.97x10 <sup>-5</sup>	4.37x10 <sup>-5</sup>	Expected	Expected
Unit 4 Emissions (lb/hr) <sup>d</sup>	1.56x10 <sup>-1</sup>	1.77x10 <sup>-1</sup>	7.70x10 <sup>-2</sup>	7.97x10 <sup>-2</sup>	1.77x10 <sup>-1</sup>	-2.13x10 <sup>-2</sup>	-0.03
<b>Beryllium</b>							
Concentration (ppm)	0.2 DL	0.08	0.08				
Emission Factor (lb/10 <sup>6</sup> Btu)	1.54x10 <sup>-5</sup>	4.37x10 <sup>-6</sup>	4.20x10 <sup>-6</sup>	4.37x10 <sup>-6</sup>	4.37x10 <sup>-6</sup>		
Unit 4 Emissions (lb/hr) <sup>d</sup>	6.23x10 <sup>-2</sup>	1.77x10 <sup>-2</sup>	1.70x10 <sup>-2</sup>	1.77x10 <sup>-2</sup>	1.77x10 <sup>-2</sup>	4.46x10 <sup>-2</sup>	0.06
<b>Mercury</b>							
Concentration (ppm)	0.2 DL	0.04	0.06				
Emission Factor (lb/10 <sup>6</sup> Btu)	1.54x10 <sup>-5</sup>	2.19x10 <sup>-6</sup>	3.20x10 <sup>-6</sup>	3.28x10 <sup>-6</sup>	3.28x10 <sup>-6</sup>		
Unit 4 Emissions (lb/hr) <sup>d</sup>	6.23x10 <sup>-2</sup>	8.85x10 <sup>-3</sup>	1.30x10 <sup>-2</sup>	1.33x10 <sup>-2</sup>	1.33x10 <sup>-2</sup>	4.90x10 <sup>-2</sup>	0.07

Note: DL = detection limit.

<sup>a</sup>From Orimulsion samples analyzed by FPL's Power Resources Central Laboratory and Clark Engineers Laboratory.

<sup>b</sup>Maximum of Residual Oil Emission Factors.

<sup>c</sup>Orimulsion emissions minus maximum on residual oil.

<sup>d</sup>Based on a maximum heat input for Unit 4 of 4050 10<sup>6</sup> Btu/hr.

<sup>e</sup>AP-42 emission factor for lead higher than Orimulsion; AP-42 was used for all emission calculations.

Table 3-4. Orimulsion and Residual Oil Emission Factors and Estimates for Selected Non-Regulated Pollutants

Pollutant	Orimulsion Sample <sup>a</sup>	Residual Oil				Emissions Increase <sup>c</sup>	
		EPA 1980	EPA 1988	EPA 1989	Maximum <sup>b</sup>	(lb/hr)	(tons/yr)
<b>Cadmium</b>							
Concentration (ppm)	0.05 DL	2.27		0.3		NO Increase	NO Increase
Emission Factor (lb/10 <sup>6</sup> Btu)	3.85x10 <sup>-6</sup>	1.24x10 <sup>-4</sup>	1.57x10 <sup>-5</sup>	1.64x10 <sup>-5</sup>	1.24x10 <sup>-4</sup>	Expected	Expected
Unit 4 Emissions (lb/hr) <sup>d</sup>	1.56x10 <sup>-2</sup>	5.02x10 <sup>-1</sup>	6.36x10 <sup>-2</sup>	6.64x10 <sup>-2</sup>	5.02x10 <sup>-1</sup>	-4.87x10 <sup>-1</sup>	-0.70
<b>Chromium</b>							
Concentration (ppm)	0.02 DL	1.3		0.4		NO	NO
Emission Factor (lb/10 <sup>6</sup> Btu)	1.54x10 <sup>-6</sup>	7.10x10 <sup>-5</sup>	2.10x10 <sup>-5</sup>	2.19x10 <sup>-5</sup>	7.10x10 <sup>-5</sup>	Increase	Increase
Unit 4 Emissions (lb/hr) <sup>d</sup>	6.23x10 <sup>-3</sup>	2.88x10 <sup>-1</sup>	8.51x10 <sup>-2</sup>	8.85x10 <sup>-2</sup>	2.88x10 <sup>-1</sup>	-2.81x10 <sup>-1</sup>	-0.41
<b>Copper</b>							
Concentration (ppm)	0.8	2.8		5.3		NO	NO
Emission Factor (lb/10 <sup>6</sup> Btu)	6.15x10 <sup>-5</sup>	1.53x10 <sup>-4</sup>	2.78x10 <sup>-4</sup>	2.90x10 <sup>-4</sup>	2.90x10 <sup>-4</sup>	Increase	Increase
Unit 4 Emissions (lb/hr) <sup>d</sup>	2.49x10 <sup>-1</sup>	6.20x10 <sup>-1</sup>	1.13	1.17	1.17	-9.24x10 <sup>-1</sup>	-1.33
<b>Manganese</b>							
Concentration (ppm)	0.5	1.33		No		NO	NO
Emission Factor (lb/10 <sup>6</sup> Btu)	3.85x10 <sup>-5</sup>	7.27x10 <sup>-5</sup>	2.60x10 <sup>-5</sup>	Emission	7.27x10 <sup>-5</sup>	Increase	Increase
Unit 4 Emissions (lb/hr) <sup>d</sup>	1.56x10 <sup>-1</sup>	2.94x10 <sup>-1</sup>	1.05x10 <sup>-1</sup>	Factor	2.94x10 <sup>-1</sup>	-1.39x10 <sup>-1</sup>	-0.20
<b>Nickel</b>							
Concentration (ppm)	59	42.2		24			
Emission Factor (lb/10 <sup>6</sup> Btu)	4.54x10 <sup>-3</sup>	2.31x10 <sup>-3</sup>	1.26x10 <sup>-3</sup>	1.31x10 <sup>-3</sup>	2.31x10 <sup>-3</sup>		
Unit 4 Emissions (lb/hr) <sup>d</sup>	1.84x10 <sup>1</sup>	9.34	5.10	5.31	9.34	9.04	13.02
<b>Selenium</b>							
Concentration (ppm)	0.5 DL	0.7		No			
Emission Factor (lb/10 <sup>6</sup> Btu)	3.85x10 <sup>-5</sup>	3.83x10 <sup>-5</sup>	2.35x10 <sup>-5</sup>	Emission	3.83x10 <sup>-5</sup>		
Unit 4 Emissions (lb/hr) <sup>d</sup>	1.56x10 <sup>-1</sup>	1.55x10 <sup>-1</sup>	9.51x10 <sup>-2</sup>	Factor	1.55x10 <sup>-1</sup>	8.51x10 <sup>-4</sup>	0.0012
<b>Vanadium</b>							
Concentration (ppm)	360	160		200			
Emission Factor (lb/10 <sup>6</sup> Btu)	2.77x10 <sup>-2</sup>	8.74x10 <sup>-3</sup>	3.52x10 <sup>-3</sup>	1.09x10 <sup>-2</sup>	1.09x10 <sup>-2</sup>	see "e"	see "e"
Unit 4 Emissions (lb/hr) <sup>d</sup>	1.12x10 <sup>2</sup>	3.54x10 <sup>1</sup>	1.43x10 <sup>1</sup>	4.43x10 <sup>1</sup>	4.43x10 <sup>1</sup>	6.79x10 <sup>1</sup>	97.7638

Note: DL = detection limit.

<sup>a</sup>From Orimulsion samples analyzed by FPL's Power Resources Central Laboratory and Clark Engineers Laboratory.<sup>b</sup>Maximum of Residual Oil Emission Factors.<sup>c</sup>Orimulsion emissions minus maximum on residual oil.<sup>d</sup>Based on a maximum heat input for Unit 4 of 4050 10<sup>6</sup> Btu/hr.<sup>e</sup>Maximum vanadium concentration for current fuel oil is 200 ppm; maximum emissions increase shown is for current conditions.



#### 4.0 EMISSIONS TESTING PROTOCOL

The test burn will require emissions testing to assure compliance with the proposed temporary emission limits and to obtain valid data for full-scale Orimulsion conversion. For both objectives, EPA and FDER approved methods will be used. Table 4-1 presents the testing protocol that will be used during the test burn. This table presents the pollutants to be monitored, test methods, test phase, boiler conditions during emission sampling, frequency of sampling, location of sampling, and the purpose of sampling.

Results obtained from the test burn will be reported monthly to FDER.

The monthly reports will include but not be limited to:

1. Orimulsion and No. 6 fuel oil usage (recorded in barrels,  $10^6$  Btu, and number of day burned),
2. Number of full power test days during the month,
3. Characteristics of Orimulsion and No. 6 fuel oil used during the month (percent sulfur, heating value, and percent ash),
4. Copies of emission test results,
5. Opacity records, and
6. Frequency of excess emission.

Monthly reports will be submitted to FDER within 21 days following the end of a month.

Table 4-1. Emissions Testing Protocol for Orimulsion Test Burn at FPL Sanford Unit 4

Pollutant	Test Method <sup>a</sup>	Test Phase	Boiler Conditions During Sampling	Frequency <sup>b</sup>	Sampling Location	Purpose of Emission Sampling
Particulate Matter	EPA Method 5	Initial Characterization	High and lows Loads	Once per Load	Stack	Determine initial Orimulsion emissions
		Operational	Steady-State Operation	Twice (O&SB)	Stack	Assure compliance during operation
		Performance	As a Function of Load	Four	Stack	Determine effects of load on emissions
		Pilot Plant	Steady-State Operation	As Needed	(IN&OUT)	Evaluate control equipment
Visible Emissions	EPA Method 9 and Continuous Opacity with Transmissometer Appendix B PS 1	Initial Characterization	High and lows Loads	Continuous	Stack	Determine initial Orimulsion emissions
		Operational	Steady-State Operation	Continuous	Stack	Assure compliance during operation
		Performance	As a Function of Load	Continuous	Stack	Determine effects of load on emissions
		Pilot Plant	Steady-State Operation	Continuous	(IN&OUT)	Evaluate control equipment
Sulfur Dioxide	Fuel Analysis using ASTM Methods	Initial Characterization	High and lows Loads	As Needed	As Burned	Determine initial Orimulsion emissions
		Operational	Steady-State Operation	As Needed	As Burned	Assure compliance during operation
	EPA Method 6C	Performance	As a Function of Load	As Needed	As Burned	Determine effects of load on emissions
		Pilot Plant	Steady-State Operation	Continuous	(IN&OUT)	Evaluate control equipment
Nitrogen Oxides	EPA Method 7E	Initial Characterization	High and lows Loads	Once per Load	Stack	Determine initial Orimulsion emissions
		Operational	Steady-State Operation	Twice (O&SB)	Stack	Assure compliance during operation
		Performance	As a Function of Load	Four	Stack	Determine effects of load on emissions
Carbon Monoxide	EPA Method 10	Initial Characterization	High and lows Loads	Once per Load	Stack	Determine initial Orimulsion emissions
		Operational	Steady-State Operation	Twice (O&SB)	Stack	Assure compliance during operation
		Performance	As a Function of Load	Four	Stack	Determine effects of load on emissions
Volatile Organic Compounds	EPA Method 25a Corrected for Methane and Ethane	Initial Characterization	High and lows Loads	Once per Load	Stack	Determine initial Orimulsion emissions
		Operational	Steady-State Operation	Twice (O&SB)	Stack	Assure compliance during operation
		Performance	As a Function of Load	Four	Stack	Determine effects of load on emissions
Lead, Arsenic, Beryllium, Mercury, and Sulfuric Acid Mist	Modified EPA Methods 5 & 8 Method 103/104	Operational	Steady-State Operation	Once	Stack	Determine uncontrolled emissions
		Pilot Plant	Steady-State Operation	Once	(IN&OUT)	Evaluate control equipment
Metals: Cr, Cd, Cu, Ni, Mn, Se, and V	Modified EPA Method 5	Operational	Steady-State Operation	Once	As Burned	Determine uncontrolled emissions

<sup>a</sup>See 40 Code of Federal Regulations (CFR) Part 60 Appendix A and Appendix B, Part 61 Appendix B.

<sup>b</sup>O = operation, SB = soot blowing.

IN = inlet to pilot control equipment; OUT = outlet from pilot control equipment.

4-2

REFERENCES

U.S. Environmental Protection Agency (EPA). 1988. Toxic Air Pollutant Emission Factors--A Compilation for Selected Air Toxic Compounds and Sources. Office of Air Quality Planning and Standards, Research Triangle Park, NC. EPA-450/2-88-006a.

**ATTACHMENT B**

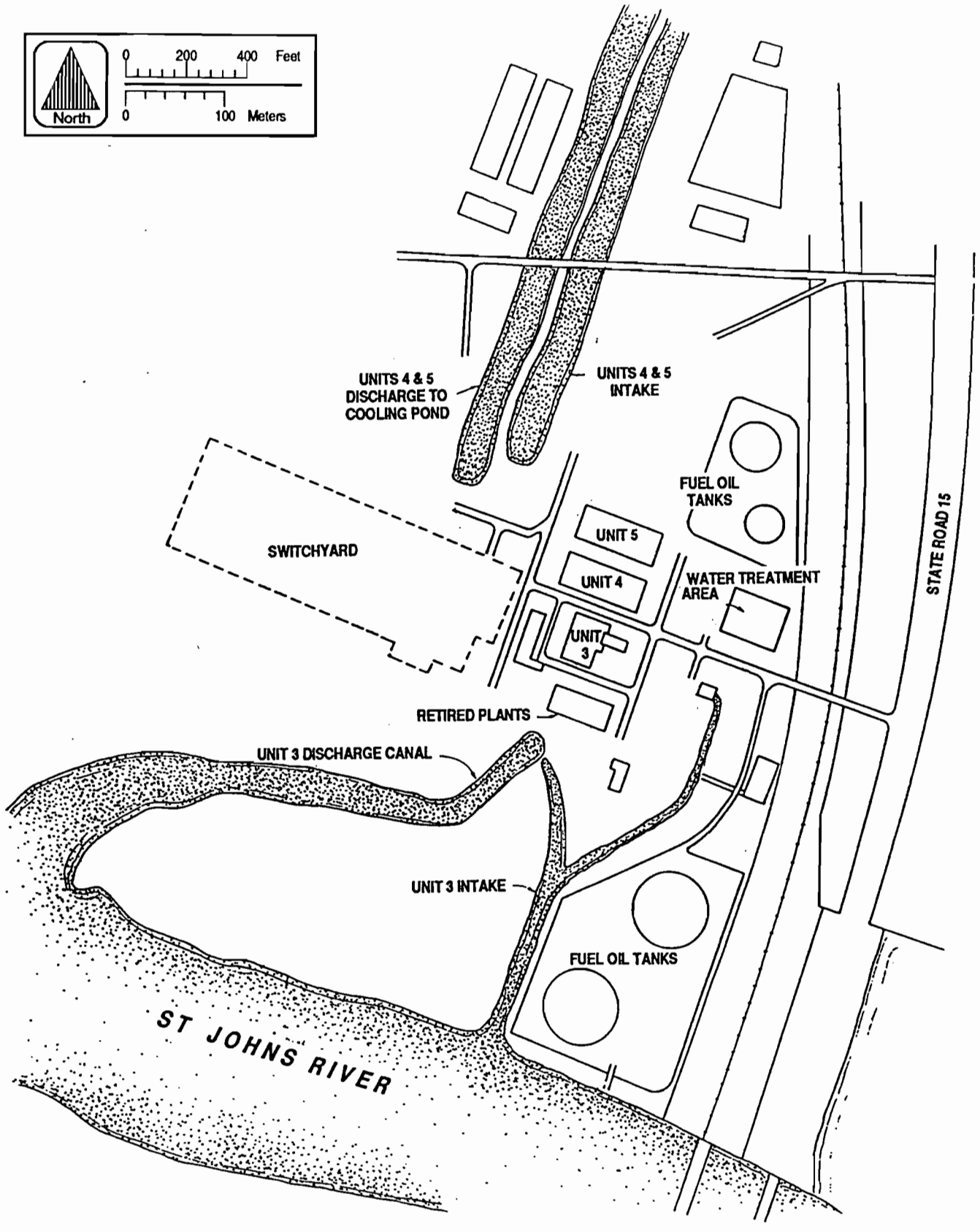
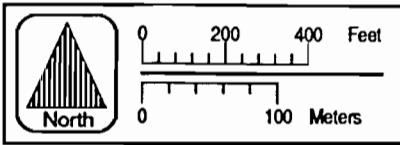

Figure C-2 PLOT PLAN OF FPL SANFORD PLANT



**ATTACHMENT C**



Figure C-1 FPL SANFORD PLANT LOCATION MAP



**ATTACHMENT D**



**AIR IMPACT ANALYSIS OF  
BURNING ORIMULSION™  
AT FLORIDA POWER & LIGHT  
COMPANY'S  
SANFORD PLANT**

**PREPARED FOR:**

**Florida Power & Light Company  
West Palm Beach, Florida**

**PREPARED BY:**

**KBN Engineering and Applied Sciences, Inc.  
1034 NW 57th Street  
Gainesville, Florida 32605**

**April 1990  
89041B2**

TABLE OF CONTENTS

1.0	INTRODUCTION	1-1
2.0	AIR QUALITY ANALYSIS APPROACH	2-1
2.1	<u>GENERAL MODELING APPROACH</u>	2-1
2.2	<u>METEOROLOGICAL DATA</u>	2-2
2.3	<u>EMISSION INVENTORY</u>	2-2
2.4	<u>OTHER AIR EMISSION SOURCES</u>	2-5
2.5	<u>RECEPTOR LOCATIONS</u>	2-6
2.6	<u>BACKGROUND CONCENTRATIONS</u>	2-10
3.0	AIR QUALITY MODELING RESULTS	3-1
3.1	<u>SIGNIFICANT IMPACT ANALYSIS</u>	3-1
3.2	<u>AAQS ANALYSIS</u>	3-5
3.3	<u>PSD ANALYSIS</u>	3-5
3.4	<u>COMPARISON OF CURRENT AND PROPOSED PREDICTED IMPACTS</u>	3-5
3.5	<u>CONCLUSIONS</u>	3-12
4.0	ADDITIONAL IMPACT ANALYSIS	4-1
4.1	<u>IMPACTS OF VEGETATION</u>	4-1
4.1.1	SULFUR DIOXIDE	4-1
4.1.2	PARTICULATE MATTER--TSP AND PM10	4-2
4.2	<u>IMPACTS TO SOILS</u>	4-2
4.3	<u>IMPACTS DUE TO ADDITIONAL GROWTH</u>	4-2
4.4	<u>IMPACTS TO VISIBILITY</u>	4-4
	REFERENCES	

LIST OF TABLES

1-1	National and State AAQS	1-2
1-2	Allowable PSD Increments and Significance Levels	1-3
2-1	Stack, Operating, and Emission Data for the Baseline and Projected Conditions at the Sanford Plant	2-3
2-2	SO <sub>2</sub> Sources Within 50 km of the FPL Sanford Plant	2-7
2-3	Summary of SO <sub>2</sub> Facilities Included in the Modeling Analysis	2-8
2-4	Modeling Parameters for SO <sub>2</sub> Facilities Interacting With FPL Sanford	2-9
2-5	Summary of Ambient SO <sub>2</sub> Data, Volusia County, 1988	2-12
3-1	Maximum Predicted Impacts For Unit 4's Increase in SO <sub>2</sub> Emission--Screening Analysis	3-2
3-2	Maximum Predicted Impacts For Unit 4's Increase in SO <sub>2</sub> Emission--Refined Analysis	3-3
3-3	Maximum Impact of Proposed Unit 4 Test Burn As Compared To Significant Impact Levels	3-4
3-4	Maximum Predicted Total SO <sub>2</sub> Concentrations From the Screening Analysis for Comparison to AAQS	3-6
3-5	Maximum Predicted Total SO <sub>2</sub> Concentrations From the Refined Analysis for Comparison AAQS	3-7
3-6	Source Contributions to the Maximum SO <sub>2</sub> Concentrations Predicted in the Refined Analysis	3-8
3-7	Maximum Predicted SO <sub>2</sub> Concentrations From the Screening Analysis for Comparison to PSD Class II Increments	3-9
3-8	Maximum Predicted SO <sub>2</sub> Concentrations From the Refined Analysis for Comparison to PSD Class II Increments	3-10
3-9	Comparison of Maximum SO <sub>2</sub> Predicted Impacts For Various Emission Strategies--Refined Analysis	3-11
4-1	SO <sub>2</sub> Doses Reported to Affect Plant Species Similar to Vegetation in the Region of the Sanford Plant	4-3

## 1.0 INTRODUCTION

Florida Power & Light Company (FPL) is proposing to test burn Orimulsion fuel in Unit 4 of their Sanford power plant. A description of the test burn is contained in Description of Orimulsion Test Burn at FPL Sanford Unit 4 (KBN, 1990). As presented in Table 3-2 of that document, the test burn would result in an increase in current emissions of three pollutants for which ambient air quality standards (AAQS) and prevention of significant deterioration (PSD) increments have been promulgated: sulfur dioxide (SO<sub>2</sub>), particulate matter (PM), and particulate matter with an aerodynamic particle diameter of 10 micrometers or less (PM<sub>10</sub>).

This document presents an air quality impact analysis that was performed to determine compliance with ambient air quality standards (AAQS) and prevention of significant deterioration (PSD) increments as a result of emission increments that would occur during the Orimulsion test burn. No increases in other criteria pollutants are expected from this test burn; therefore, this report addresses only impacts of PM and SO<sub>2</sub>. The emission increases considered in this analysis are due to test burning in Unit 4 for an equivalent of 120 full-power test days.

The Sanford plant is located approximately 20 miles north of Orlando on the St. Johns River in southern Volusia County. Since all counties in the vicinity of the Sanford plant currently are meeting the AAQS for SO<sub>2</sub>, PM, and PM<sub>10</sub>, the proposed test burn would have to comply with the AAQS and PSD increments that are applicable for sources located in attainment areas. The national and Florida AAQS and PSD increments are presented in Tables 1-1 and 1-2, respectively.

Table 1-1. National and State AAQS

Pollutant	Averaging Time	AAQS ( $\mu\text{g}/\text{m}^3$ )		
		National		State of Florida
		Primary Standard	Secondary Standard	
Particulate Matter (PM10)	Annual Arithmetic Mean	50	50	50
	24-Hour Maximum <sup>a</sup>	150	150	150
Sulfur Dioxide	Annual Arithmetic Mean	80	NA	60
	24-Hour Maximum <sup>b</sup>	365	NA	260
	3-Hour Maximum <sup>b</sup>	NA	1,300	1,300
Carbon Monoxide	8-Hour Maximum <sup>b</sup>	10,000	10,000	10,000
	1-Hour Maximum <sup>b</sup>	40,000	40,000	40,000
Nitrogen Dioxide	Annual Arithmetic Mean	100	100	100
Ozone	1-Hour Maximum <sup>c</sup>	235	235	235
Lead	Calendar Quarter Arithmetic Mean	1.5	1.5	15

Note: Particulate matter (PM10) refers to particulate matter with aerodynamic diameter less than or equal to 10 micrometers ( $\mu\text{m}$ ).

NA = Not applicable, i.e., no standard exists.

<sup>a</sup>Achieved when the expected number of exceedances per year is less than 1.

<sup>b</sup>Maximum concentration not to be exceeded more than once per year.

<sup>c</sup>Achieved when the expected number of days per year with concentrations above the standard is less than 1.

Sources: 40 CFR Part 50.  
Chapter 17-2.300, F.A.C.

Table 1-2. Allowable PSD Increments and Significance Levels

Pollutant	Averaging Time	PSD Increments ( $\mu\text{g}/\text{m}^3$ )		Significant Impact Levels ( $\mu\text{g}/\text{m}^3$ )
		Class I	Class II	
Particulate Matter (PM)	Annual Geometric Mean	5	19	1
	24-Hour Maximum <sup>a</sup>	10	37	5
Particulate Matter (PM10)	Annual Arithmetic Mean	4 <sup>c</sup>	17 <sup>c</sup>	1
	24-Hour Maximum <sup>b</sup>	8 <sup>c</sup>	30 <sup>c</sup>	5
Sulfur Dioxide	Annual Arithmetic Mean	2	20	1
	24-Hour Maximum <sup>a</sup>	5	91	5
	3-Hour Maximum <sup>a</sup>	25	512	25
Carbon Monoxide	8-Hour Maximum <sup>a</sup>	NA	NA	500
	1-Hour Maximum <sup>a</sup>	NA	NA	2,000
Nitrogen Dioxide	Annual Arithmetic Mean	2.5 <sup>d</sup>	25 <sup>d</sup>	1

Note: Particulate matter (PM) refers to total suspended particulate matter. Particulate matter (PM10) refers to particulate matter with aerodynamic diameter less than or equal to 10 micrometers ( $\mu\text{m}$ ).

NA = Not applicable, i.e., no standard exists.  
 $\mu\text{g}/\text{m}^3$  = micrograms per cubic meter.

<sup>a</sup>Maximum concentration not to be exceeded more than once per year.

<sup>b</sup>Achieved when the expected number of exceedances per year is less than 1.

<sup>c</sup>Proposed PSD increments.

<sup>d</sup>The State of Florida has not yet adopted the PSD increments for  $\text{NO}_2$  concentrations.

Sources: 40 CFR 52.21.  
 Chapter 17-2.310, F.A.C.

## 2.0 AIR QUALITY ANALYSIS APPROACH

### 2.1 GENERAL MODELING APPROACH

The modeling approach followed U.S. Environmental Protection Agency (EPA) and Florida Department of Environmental Regulation (FDER) modeling guidelines for determining compliance with AAQS and PSD increments (EPA, 1986). In general, when model predictions are used to determine compliance with AAQS and PSD increments, current policies stipulate that the highest annual average and highest, second-highest short-term (i.e., 24 hours or less) concentrations be compared to the applicable standard when 5 years of meteorological data are used. The highest, second-highest concentration is calculated for a receptor field by:

1. Eliminating the highest concentration predicted at each receptor,
2. Identifying the second-highest concentration at each receptor, and
3. Selecting the highest concentration among these second-highest concentrations.

This approach is consistent with the air quality standards, which permit a short-term average concentration to be exceeded once per year at each receptor.

To develop the maximum short-term concentrations for the proposed facility, the general modeling approach was divided into screening and refined phases to reduce the computation time required to perform the modeling analysis. The basic difference between the two phases is the receptor grid used when predicting concentrations and the number of years of meteorological data evaluated. Concentrations for the screening phase were predicted using a coarse receptor grid and a 5-year meteorological record. Using the year which produced the highest, second-highest concentration, the refined modeling was performed with a denser receptor grid centered on the receptor at which the highest second-highest concentration was produced from the screening phase. The air dispersion model was then reexecuted for the full year during which this concentration occurred during the screening phase results.

The Industrial Source Complex Short-Term (ISCST) dispersion model (EPA, 1987) was used to evaluate the pollutant emissions from the Sanford facility and other existing major facilities in the vicinity. This model is recommended for use by EPA and FDER for applications for point sources, such as the Sanford plant. EPA regulatory options were selected for use to address maximum impacts. Based on a review of the land use around the Sanford facility, the rural mode was selected based on the degree of residential, industrial, and commercial development within 3 kilometers (km) of the site.

## 2.2 METEOROLOGICAL DATA

Meteorological data used in the ISCST model to determine air quality impacts consisted of a concurrent 5-year period of hourly surface weather observations and twice-daily upper air soundings from the National Weather Service (NWS) stations at Orlando International Airport and Tampa International Airport, respectively. The 5-year period of meteorological data used in the analysis was from 1982 through 1986. The NWS station in Orlando was selected for use in the study because it is the closest primary weather station to the study area features. This station also has the most readily available and complete database which is representative of the plant site.

## 2.3 EMISSION INVENTORY

Stack, operating, and emission data for Units 3, 4, and 5 at Sanford for PSD baseline and test burn conditions are presented in Table 2-1. In determining PSD increment consumption for Sanford, only the fuel change in Unit 4 will consume PSD increment. For addressing PSD increment consumption, the SO<sub>2</sub> increment consumed is the difference in emissions from the PSD baseline to the test burn condition. The PSD baseline SO<sub>2</sub> emissions for Units 3, 4, and 5 are based on 1.1 pounds per million British thermal units (lb/10<sup>6</sup> Btu) heat input. The current SO<sub>2</sub> emissions from Sanford Units 3, 4, and 5 are 1.65 lb/10<sup>6</sup> Btu. During the Orimulsion test burn, Unit 4's emission rate will temporarily increase to 4.3 lb/10<sup>6</sup> Btu while emissions from Units 3 and 5 will decrease to 1.1 lb/10<sup>6</sup> Btu. [Refer



Table 2-1. Stack, Operating, and Emission Data for the Baseline and Projected Conditions at the Sanford Plant (Page 1 of 2)

Parameter	Unit 3	Unit 4	Unit 5
Boiler Heat Input, Btu/hr	1,650	4,050	4,050
Stack Height, ft (m)	300 (91.4)	400 (121.9)	400 (121.9)
Stack Diameter, ft (m)	9.5 (2.9)	19.2 (5.84)	19.2 (5.84)
Stack Gas Velocity ft/sec (m/sec)	112.9 (34.42)	73.4 (22.38)	73.4 (22.38)
Stack Gas Exit Temperature °F (K)	275 (408)	313 (429)	313 (429)
<u>Baseline Emission Rates</u>			
SO <sub>2</sub>			
lb/10 <sup>6</sup> Btu	1.1	1.1	1.1
lb/hr (g/sec)	1,815 (228.7)	4,455 (561.3)	4,455 (561.3)
PM			
lb/10 <sup>6</sup> Btu	0.125 <sup>a</sup>	0.125 <sup>a</sup>	0.125 <sup>a</sup>
lb/hr (g/sec)	165.0 (20.8)	405.0 (51.0)	405.0 (51.0)
PM10			
lb/10 <sup>6</sup> Btu	0.09	0.09	0.09
lb/hr (g/sec)	146.0 (44.5)	359.0 (45.2)	359.0 (45.2)
<u>Projected Emission Rates</u>			
SO <sub>2</sub>			
lb/10 <sup>6</sup> Btu	1.1	4.3	1.1
lb/hr (g/sec)	1,815 (228.7)	17,415 (2,194) <sup>b</sup>	4,455 (561.3)
PM			
lb/10 <sup>6</sup> Btu	0.125 <sup>a</sup>	0.338 <sup>b</sup>	0.125 <sup>a</sup>
lb/hr (g/sec)	206.3 (26.0)	1,369 (172.5)	506.3 (63.8)

Table 2-1. Stack, Operating, and Emission Data for the Baseline and Projected Conditions at the Sanford Plant (Page 2 of 2)

Parameter	Unit 3	Unit 4	Unit 5
PM10			
1b/10 <sup>6</sup> Btu	0.09	0.338 <sup>b</sup>	0.09
1b/hr (g/sec)	146.0 (44.5)	1,369 (172.5)	359.0 (45.2)

Note: Btu/hr = British thermal units per hour.

ft/sec = feet per second.

g/sec = grams per second.

K = degrees Kelvin.

1b/10<sup>6</sup> Btu = pounds per million British thermal units.

1b/hr = pounds per hour.

m = meters.

m/sec = meters per second.

<sup>a</sup>Based on emissions of 0.1 lb/10<sup>6</sup> Btu for 21 hours and excess emissions of 0.3 lb/10<sup>6</sup> Btu for 3 hours.

<sup>b</sup>Based on emissions of 0.3 lb/10<sup>6</sup> Btu for 21 hours and excess of 0.6 lb/10<sup>6</sup> Btu for 3 hours.

to test burn description, (KBN, 1990) for discussion of emission estimates]. The baseline PM and PM10 emission rate for Units 3, 4, and 5 is <sup>0.093</sup>0.125 lb/10<sup>6</sup> Btu. The proposed test burn will result in only Unit 4's emissions temporarily increasing to 0.338 lb/10<sup>6</sup> Btu, based on a 24-hour average.

The baseline PM10 emission rate for Unit 4 is <sup>0.065</sup>0.09 lb/10<sup>6</sup> Btu, which is 70 percent of the PM rate. The PM and PM10 emission rates assume that excess emissions occur for 3 hours in a 24-hour period. For Units 3 and 5, the PM emission rate is assumed to be 0.1 lb/10<sup>6</sup> Btu for 21 hours with excess emissions of 0.3 lb/10<sup>6</sup> Btu for 3 hours. For Unit 4, both the PM and PM10 emission rates are assumed to be 0.3 lb/10<sup>6</sup> Btu for 21 hours with excess emissions of 0.6 lb/10<sup>6</sup> Btu for 3 hours.

#### 2.4 OTHER AIR EMISSION SOURCES

Preliminary modeling of the Sanford plant's increase in emissions (refer to Section 3.0), indicated that the predicted SO<sub>2</sub> concentration were above the significant impact levels. The predicted PM concentrations were predicted to be below the significant impact levels. Therefore, the modeling analysis considered only the potential interaction of SO<sub>2</sub> emissions between the Sanford plant and other sources.

An emission inventory for other SO<sub>2</sub> sources was developed from the FDER's AIR10 and APIS inventories, permits, and prior modeling studies. These databases were used to obtain a list of all sources within 50 km of the Sanford plant. The counties included in this inventory were Volusia, Orange, Seminole, and Lake. For the FPL Sanford and the FPC Turner and Debary plants, source parameters were obtained from permits and previous air dispersion modeling analyses. The AIR10 and APIS inventories were used to obtain stack parameters for other sources.

All facilities located within 50 km of the Sanford site with SO<sub>2</sub> emissions greater than 25 tons per year (TPY) were included for consideration in the modeling analysis. A listing of facilities, locations, relative position

with respect to the Sanford plant, and maximum allowable emissions is presented in Table 2-2. Prior to modeling, these facilities were subject to further screening to determine the potential for source interaction with the Sanford plant.

The "Screening Threshold" method, developed by the North Carolina Department of Natural Resources and Community Development, was used to effectively eliminate sources from the modeling analysis. This method is a tool that has been designed to objectively eliminate from the emission inventory those facilities that are not likely to have significant interaction with the source undergoing evaluation. For this analysis, KBN employed a modification of this technique that assumes that the short-term interaction impacts will be more critical than the annual impacts. In general, facilities that were considered for initial screening are those that have maximum allowable emissions greater than 25 TPY and are within 50 km of the Sanford plant. From this initial list, sources with emission rates in excess of an emission threshold, Q (in TPY), were employed in the modeling. The parameter Q is defined as 20 times the distance (km) between the particular source and the source undergoing evaluation. A listing of the SO<sub>2</sub> facilities included in modeling is presented in Table 2-3. Those facilities below the screening threshold are assumed not to interact significantly with the Sanford plant on a short-term basis and are eliminated from further consideration in the modeling analysis.

Modeling parameters for interacting sources included in this analysis are presented in Table 2-4. As seen in the table, the Stanton Energy Center and New Smyrna Beach Utilities are PSD increment-consuming sources which were modeled in conjunction with Sanford plant's increase in emissions to determine compliance with PSD increments.

## 2.5 RECEPTOR LOCATIONS

For the screening phase, receptors were located in radial grids that consisted of 36 radials with radials located at 10° increments. Two sets of receptor grids were used. The first set consisted of receptors located

Table 2-2. SO<sub>2</sub> Sources (>25 TPY) Within 50 km of the FPL Sanford Plant

APIS Facility Identification Number	Facility	County	UTM Coordinates (km)		Location (km <sup>a</sup> ) Relative to Sanford Facility		Distance From Sanford Facility (km)	Direction From Sanford Facility (degrees)	Maximum Allowable SO <sub>2</sub> Emissions (TPY)
			East	North	X	Y			
30ORG480014	FPC--Rio Pinar	Orange	475.2	3156.8	6.9	-33.6	34.3	168	109
30ORG480014	Orlando City Incinerator	Orange	456.3	3152.7	-12.0	-37.7	39.6	198	16
30ORG480006	Coca Cola/Foods Division	Orange	445.9	3173.6	-22.4	-16.8	28.0	233	13
30ORG480048	American Asphalt Inc.	Orange	444.8	3158.2	-23.5	-32.2	39.9	216	53
30ORG480053	Winter Garden Citrus Corp.	Orange	443.8	3159.6	-24.5	-30.8	39.4	219	145
30ORG480055	Steel Drum Service of Florida	Orange	439.9	3178.2	-28.4	-12.2	30.9	247	12
30ORG480062	Orlando City Sludge Dryer	Orange	478.2	3166.5	9.9	-23.9	25.9	157	22
30ORG480063	Florida Hospital	Orange	463.8	3160.7	-4.5	-29.7	30.0	189	36
30ORG480066	West Orange Memorial Hospital	Orange	443.1	3160.5	-25.2	-29.9	39.1	220	1
30ORG480067	Orlando Regional Medical Center	Orange	463.1	3155.3	-5.2	-35.1	35.5	188	10
30ORG480068	Zellwood Farms	Orange	440.8	3180.0	-27.5	-10.4	29.4	249	101
30ORG480087	Naval Training Center	Orange	467.1	3160.6	-1.2	-29.8	29.8	182	9
30ORG480088	Ralston Purina Co.	Orange	451.1	3167.7	-17.2	-22.7	28.5	217	54
30ORG480095	FMC Corp/Airline Equip. Div.	Orange	459.8	3148.2	-8.5	-42.2	43.0	191	11
30ORG480097	National Linen Service	Orange	462.2	3155.6	-6.1	-34.8	35.3	190	355
30ORG480137	OUC--Stanton Energy Center	Orange	483.5	3150.6	15.2	-39.8	42.6	159	41,304
30ORG480138	AT&T Technologies, Inc.	Orange	459.3	3153.6	-9.0	-36.8	37.9	194	64
30ORG480156	Rogers Group, Inc.	Orange	455.8	3167.1	-12.5	-23.3	26.4	208	164
30ORG350004	Florida Food Products	Lake	431.5	3194.1	-36.8	3.7	37.0	276	97
30ORG350005	Golden Gem Growers	Lake	434.1	3196.0	-34.2	5.6	34.7	279	3
30ORG350009	Sloan Construction	Lake	431.6	3152.6	-36.7	-37.8	52.7	224	112
30ORG350015	Alad Construction	Lake	433.6	3158.3	-34.7	-32.1	47.3	227	249
30ORG350039	C A Meyer Paving and Constr.	Lake	433.6	3158.3	-34.7	-32.1	47.3	227	31
30ORL590002	Central Florida Drum	Seminole	474.7	3173.4	6.4	-17.0	18.2	159	4
30ORL590006	Coca Cola	Seminole	459.4	3170.5	-8.9	-19.9	21.8	204	2
30ORL590007	L D Plante	Seminole	474.5	3176.2	6.2	-14.2	15.5	156	34
30ORL590014	David "M" Co.	Seminole	470.2	3177.2	1.9	-13.2	13.3	172	13
30ORL590019	Macasphalt	Seminole	470.2	3175.8	1.9	-14.6	14.7	173	22
30ORL590022	Florida Hospital	Seminole	463.7	3170.9	-4.6	-19.5	20.0	193	6
30ORL590033	C A Meyer Paving and Constr.	Seminole	469.5	3189.0	1.2	-1.4	1.8	139	80
30ORL640002	Brunswick Corp.	Volusia	475.5	3214.5	7.2	24.1	25.2	17	1
30ORL640003	New Smyrna Beach Utilities	Volusia	505.9	3215.0	37.6	24.6	44.9	57	3,826
30ORL640004	New Smyrna Beach Power Plant	Volusia	507.7	3209.8	39.4	19.4	43.9	64	12
30ORL640013	Sloan Construction	Volusia	488.8	3242.6	20.5	52.2	56.1	21	112
30ORL640020	Florida Power--Turner	Volusia	473.4	3193.3	5.1	2.9	5.9	60	29,287
30ORL640028	Florida Power--De Bary	Volusia	467.5	3197.3	-0.8	6.9	6.9	353	8,353
30ORL640031	Halifax Paving	Volusia	488.7	3243.0	20.4	52.6	56.4	21	25
30ORL640037	Port Orange City Incinerator	Volusia	498.0	3222.1	29.7	31.7	43.4	43	8
30ORL640043	Martin Asphalt Co.	Volusia	496.7	3224.5	28.4	34.1	44.4	40	50
30ORL640053	Keller Kitchen Cabinets	Volusia	465.2	3210.3	-3.1	19.9	20.1	351	2
30ORL640064	Martin Asphalt	Volusia	467.9	3193.1	-0.4	2.7	2.7	352	536
30ORL640077	Para Excavating, Inc.	Volusia	508.4	3206.9	40.1	16.5	43.4	68	16

<sup>a</sup>The UTM coordinates of the FPL Sanford Plant are 468.3 km east and 3190.4 km north.

Table 2-3. Summary of SO<sub>2</sub> Facilities Included in the Modeling Analysis

APIS Facility Identification Number	Facility	Distance From Sanford Facility (km)	Direction From Sanford Facility (degrees)	Maximum SO <sub>2</sub> Emissions (TPY)	Q, Emission Threshold (TPY) (20 x Distance)	Included in Modeling
30ORG480014	FPC -Rio Pinar	34.3	168	109	686	NO
30ORG480014	Orlando City Incinerator	39.6	198	16	791	NO
30ORG480006	Coca Cola/Foods Division	28.0	233	13	560	NO
30ORG480048	American Asphalt Inc.	39.9	216	53	797	NO
30ORG480053	Winter Garden Citrus Corp.	39.4	219	145	787	NO
30ORG480055	Steel Drum Service of Florida	30.9	247	12	618	NO
30ORG480062	Orlando City Sludge Dryer	25.9	157	22	517	NO
30ORG480063	Florida Hospital	30.0	189	36	601	NO
30ORG480066	West Orange Memorial Hospital	39.1	220	1	782	NO
30ORG480067	Orlando Regional Medical Center	35.5	188	10	710	NO
30ORG480068	Zellwood Farms	29.4	249	101	588	NO
30ORG480087	Naval Training Center	29.8	182	9	596	NO
30ORG480088	Ralston Purina Co.	28.5	217	54	570	NO
30ORG480095	FMC Corp/Airline Equip. Div.	43.0	191	11	861	NO
30ORG480097	National Linen Service	35.3	190	355	707	NO
30ORG480137	OUC -Stanton Energy Center	42.6	159	41,304	852	YES <sup>a</sup>
30ORG480138	AT&T Technologies, Inc.	37.9	194	64	758	NO
30ORG480156	Rogers Group, Inc.	26.4	208	164	529	NO
30ORG350004	Florida Food Products	37.0	276	97	740	NO
30ORG350005	Golden Gem Growers	34.7	279	3	693	NO
30ORG350009	Sloan Construction	52.7	224	112	1,054	NO
30ORG350015	Alad Construction	47.3	227	249	945	NO
30ORG350039	C A Meyer Paving and Constr.	47.3	227	31	945	NO
30ORL590002	Central Florida Drum	18.2	159	4	363	NO
30ORL590006	Coca Cola	21.8	204	2	436	NO
30ORL590007	L D Plante	15.5	156	34	310	NO
30ORL590014	David "M" Co.	13.3	172	13	267	NO
30ORL590019	Macasphalt	14.7	173	22	294	NO
30ORL590022	Florida Hospital	20.0	193	6	401	NO
30ORL590033	C A Meyer Paving and Constr.	1.8	139	180	37	YES
30ORL640002	Brunswick Corp.	25.2	17	1	503	NO
30ORL640003	New Smyrna Beach Utilities	44.9	57	3,826	899	YES <sup>a</sup>
30ORL640004	New Smyrna Beach Power Plant	43.9	64	12	878	NO
30ORL640013	Sloan Construction	56.1	21	112	1,122	NO
30ORL640020	Florida Power -Turner	5.9	60	29,287	117	YES
30ORL640028	Florida Power -Debary	6.8	353	8,353	137	YES
30ORL640031	Halifax Paving	56.4	21	25	1,128	NO
30ORL640037	Port Orange City Incinerator	43.4	43	8	869	NO
30ORL640043	Martin Asphalt Co.	44.4	40	50	888	NO
30ORL640053	Keller Kitchen Cabinets	20.1	351	2	403	NO
30ORL640064	Martin Asphalt	2.7	352	536	55	YES
30ORL640077	Para Excavating, Inc.	43.4	68	16	867	NO

<sup>a</sup>Also considered to consume PSD increment.

Table 2-4. Modeling Parameters for SO<sub>2</sub> Facilities Interacting With FPL Sanford

Model. ID No.	Source	Name	Emissions		Height		Velocity		Temperature		Diameter	
			lb/hr	(g/s)	ft	(m)	fps	(mps)	°F	(°K)	ft	(m)
20002	FPC	Turner #2	990	(124.7)	237	(72.3)	58	(17.7)	260	(400)	6.0	(1.83)
20003	FPC	Turner #3	2,255	(284.1)	237	(72.3)	79	(24.1)	315	(430)	6.0	(1.83)
20004	FPC	Turner #4	2,255	(284.1)	237	(72.3)	76	(23.2)	270	(405)	6.4	(1.95)
20012	Turner	GT 1&2	329	(40.6)	39	(11.9)	63	(19.2)	960	(789)	12.9	(3.93)
20034	Turner	GT 3&4	867	(109.0)	35	(10.7)	100	(30.5)	900	(755)	19.1	(5.82)
28012	FPC	Debary 1&2	143	(18.0)	30	(9.10)	20	(6.1)	320	(433)	2.5	(0.76)
28016	Debary	GT 1-6	1,764	(222.3)	30	(9.10)	70	(21.3)	750	(672)	7.8	(2.40)
99937	OUC	Stanton En <sup>a</sup>	9,430	(1188.2)	550	(167.6)	83	(25.3)	127	(326)	19.0	(5.79)
33001	C.A.Meyer	Pav	41	(5.2)	34	(10.4)	103	(31.4)	325	(436)	3.2	(0.98)
99903	New Symrma Beach <sup>a</sup>		873.5	(110.1)	29	(8.8)	78	(23.8)	650	(616)	2.2	(0.67)
64001	Martin	Asphalt	122.3	(15.4)	20	(6.1)	90	(27.4)	325	(436)	3.1	(0.94)

<sup>a</sup>PSD increment-consuming source.

along each radial at distances of 1,000, 2,000, 3,000, 5,000, 7,500, 10,000, 20,000, 30,000, 40,000, and 50,000 meters (m) to determine the significant impact area. The second set of receptors, which were used to determine maximum impacts, were input at distances of 100, 400, 700, 1,000, 1,300, 1,600, 2,000, 3,000, 4,000, and 5,000 m along each radial. For both grids, the Sanford plant was assumed to be at the center of the grids. Modeling with the latter receptor grid indicated that maximum short-term impacts were occurring at the 5,000-m distance in the direction of the FPC Turner plant. Therefore, additional receptors located at distances of 5,500, 6,000, 6,500, 7,000, and 7,500 m were modeled for directions from 50° to 70° from the Sanford plant.

The refinement phase of the modeling used receptor grids with a radial receptor spacing of 100 m and a 2° spacing centered on the receptor at which the highest, second-highest maximum concentration was produced in the screening grid. The refined grids were bordered by the adjacent screening grid receptors. To ensure that a valid highest, second-highest concentration was calculated, concentrations were predicted for the entire year with the refined grid.

The nearest PSD Class I area to the Sanford plant is the Chassahowitzka National Wilderness Area, located 125 km west-southwest of the Sanford plant. Since this area is over 100 km from the plant, impacts on this area are not expected to be significant and were not considered in this analysis.

## 2.6 BACKGROUND CONCENTRATIONS

Background concentrations are concentrations due to sources not explicitly modeled and are added to the maximum predicted impacts to produce a total air quality concentration that can be compared to the AAQS. Background concentrations can be estimated from ambient data measured at air monitoring stations.



Volusia County has one continuous SO<sub>2</sub> monitor located in Debary. Ambient air quality data from the year 1988 are summarized in Table 2-5. The highest measured concentrations reported by FDER in 1988 were assumed to represent the background SO<sub>2</sub> levels in the vicinity of the Sanford plant. These concentrations are 100, 28, and 4 µg/m<sup>3</sup> for the 3-hour, 24-hour, and annual averaging periods, respectively. It should be noted that the highest measurements most likely include contributions from the nearby Debary and Turner plants. Because these plants are also modeled in the analysis, the background values are considered to provide a conservative estimate of total air quality.

Table 2-5. Summary of Ambient SO<sub>2</sub> Data, Volusia County, 1988

Site No.	Site Name	Time Period	No. Obs.	Sulfur Dioxide Concentration ( $\mu\text{g}/\text{m}^3$ )				
				Max. 3-hr	2nd Max. 3-hr	Max. 24-hr	2nd Max. 24-hr	Arith. Mean
0930001F02	Debary	Jan-Dec	8425	100	90	28	25	4

Source: FDER, 1988.

### 3.0 AIR QUALITY MODELING RESULTS

#### 3.1 SIGNIFICANT IMPACT ANALYSIS

The maximum impact of the proposed increase in SO<sub>2</sub> emissions from Sanford Unit 4 is presented in Tables 3-1 and 3-2. The results indicate that the maximum predicted SO<sub>2</sub> concentrations are above the significant impact levels, and, therefore, further modeling analysis is required for this pollutant to demonstrate compliance with PSD increments and AAQS. Additional modeling with a receptor grid extended out to 50 km indicated that the proposed test burn is significant out to 50 km.

Maximum impacts for other pollutants for which the proposed test burn had a significant increase in emissions (see Table 2-4) were determined by ratioing the proposed allowable increase in emissions with that for SO<sub>2</sub>. The ratios are then converted to maximum concentrations by multiplying them against the maximum SO<sub>2</sub> impacts for each respective averaging time. The resulting maximum concentrations are presented in Table 3-3 for all significant pollutants. The table indicates that both PM and PM<sub>10</sub> are below significant impact levels for the proposed fuel change to Unit 4.

Because maximum impacts for these pollutants do not exceed their significant impact levels, further modeling to determine compliance with allowable PSD increments and AAQS is required for SO<sub>2</sub> only.

As a result, an inventory of other SO<sub>2</sub> sources out to 50 km was evaluated for interaction with the Sanford plant. The maximum predicted PM concentrations were below the significant impact levels at all modeled distances. Because the proposed impacts for the test burn are not significant for PM, further modeling analysis is not required for that pollutant.

Table 3-1. Maximum Predicted Impacts For Unit 4's Increase in SO<sub>2</sub> Emissions--Screening Analysis

Averaging Time	Year	Concentration (µg/m <sup>3</sup> )	Dir. (°)	Dist. (m)	Day	Hour Ending
Annual	1982	3.0	360	5,000	-	-
	1983	3.1	240	4,000	-	-
	1984	3.4	240	5,000	-	-
	1985	3.2	260	5,000	-	-
	1986	3.1	240	4,000	-	-
3-Hour	1982	228	260	3,000	305	12
	1983	264	160	1,300	82	12
	1984	320	20	1,300	209	15
	1985	260	300	1,000	193	12
	1986	278	240	1,300	137	15
24-Hour	1982	45	60	3,000	237	-
	1983	43	300	4,000	130	-
	1984	53	230	1,300	82	-
	1985	55	200	1,300	148	-
	1986	51	300	3,000	273	-

Table 3-2. Maximum Predicted Impacts For Unit 4's Increase in SO<sub>2</sub> Emissions--Refined Analysis

Averaging Time	Year	Concentration (µg/m <sup>3</sup> )	Dir. (°)	Dist. (m)	Day	Hour Ending
Annual	1984	3.4	240	4900	-	-
3-Hour	1984	348	22	1200	209	15
24-Hour	1984	56	226	1300	259	-
	1985	59	202	1100	148	-

Table 3-3. Maximum Impact of Proposed Unit 4 Test Burn As Compared To Significant Impact Levels

Pollutant/ Averaging Time	Modeling Applicability			Monitoring Applicability	
	Maximum Impact ( $\mu\text{g}/\text{m}^3$ )	Significant Impact Level ( $\mu\text{g}/\text{m}^3$ )	Further Analysis Required?	<u>De Minimus</u> Air Quality Levels ( $\mu\text{g}/\text{m}^3$ )	Monitoring Data Required?
<u>Sulfur Dioxide</u>					
Annual	3.4	1	YES		
3-Hour	348	25	YES		
24-Hour	59	5	YES	13	YES
<u>Particulates-TSP</u>					
Annual	0.2	1	NO	NA	
24-Hour	3.9	5	NO		
<u>Particulates-PM10</u>					
Annual	0.3	1	NO		
24-Hour	4.6	5	NO	NA	
<u>Sulfuric Acid Mist</u>					
Annual	0.03	NA <sup>a</sup>		NA <sup>b</sup>	

<sup>a</sup>Significant impact levels do not exist for Sulfuric Acid Mist.

<sup>b</sup>No ambient air measurement method exists.

### 3.2 AAQS ANALYSIS

The SO<sub>2</sub> impacts for the screening analysis due to all sources in the vicinity of the Sanford plant are presented in Table 3-4. The maximum SO<sub>2</sub> impacts for the refined analysis due to all sources in the vicinity of the Sanford plant are presented in Table 3-5. The maximum refined 3-hour, 24-hour, and annual average concentrations are 895, 254, and 31 micrograms per cubic meter ( $\mu\text{g}/\text{m}^3$ ), respectively, which are below the AAQS of 1300, 260, and 60  $\mu\text{g}/\text{m}^3$ , respectively. Source contributions at each of these maximum modeled concentration are shown in Table 3-6. The Sanford plant's contributions to the maximum 3-hour, 24-hour, and annual concentrations are 23, 24, and 16 percent of the total concentration (including background) for each respective averaging time.

### 3.3 PSD ANALYSIS

The screening analysis results for SO<sub>2</sub> Class II increment consumption for the proposed Orimulsion test burn at the Sanford plant and other PSD sources in the Sanford plant's vicinity are presented in Table 3-7. Results from the refined analysis are presented in Table 3-8. The maximum 3-hour, 24-hour, and annual average concentrations are 348, 59, and 4.8  $\mu\text{g}/\text{m}^3$ , respectively, which are 68, 65, and 24 percent of the allowable increments, respectively.

### 3.4 COMPARISON OF CURRENT AND PROPOSED PREDICTED IMPACTS

A comparison of maximum impacts for the current and proposed SO<sub>2</sub> emission scenarios for Sanford are presented in Table 3-9. Maximum impacts for the current emissions limit of 1.65 lb/10<sup>8</sup> Btu for Units 3, 4, and 5 are 6.3, 85, and 484  $\mu\text{g}/\text{m}^3$ , for the annual, 24-hour, and 3-hour averaging times, respectively. The corresponding State of Florida AAQS are 60, 260, and 1,300  $\mu\text{g}/\text{m}^3$ , respectively.

The proposed emissions produced slightly higher impacts. The maximum proposed impacts due to Sanford are 7.5, 115, and 667  $\mu\text{g}/\text{m}^3$ . The increases in the maximum impact are 19 percent for annual averaging, 35 percent for 24-hour averaging, and 37 percent for 3-hour averaging.

Table 3-4. Maximum Predicted Total SO<sub>2</sub> Concentrations From the Screening Analysis for Comparison to AAQS

Averaging Period	Concentration ( $\mu\text{g}/\text{m}^3$ )			Receptor Location <sup>a</sup>		Period		
	Total	Total Due To		Direction (°)	Distance (km)	Julian Day	Hour Ending	Year
		Modeled Sources	Background					
3-hour <sup>b</sup>	895	795	100	60	7.0	165	12	1982
	850	750	100	60	7.5	136	15	1983
	885	785	100	60	6.5	225	15	1984
	879	779	100	60	7.0	285	15	1985
	850	750	100	70	6.5	142	15	1986
24-hour <sup>b</sup>	254	226	28	60	7.0	165	24	1982
	174	146	28	50	6.0	122	24	1983
	209	181	28	70	6.5	155	24	1984
	193	165	28	60	7.0	73	24	1985
	204	176	28	70	7.0	118	24	1986
Annual	30	26	4	350	4.0	--	--	1982
	30	26	4	350	5.0	--	--	1983
	31	27	4	340	3.0	--	--	1984
	29	25	4	360	3.0	--	--	1985
	29	25	4	340	3.0	--	--	1986

Note: AAQS are 1,300  $\mu\text{g}/\text{m}^3$ , 3-hour  
260  $\mu\text{g}/\text{m}^3$ , 24-hour  
60  $\mu\text{g}/\text{m}^3$ , annual

<sup>a</sup>Relative to the location of the Sanford plant.

<sup>b</sup>Highest, second-highest concentrations predicted for this averaging period.



Table 3-5. Maximum Predicted Total SO<sub>2</sub> Concentrations From the Refined Analysis for Comparison to AAQS

Averaging Period	<u>Concentration (µg/m<sup>3</sup>)</u>			<u>Receptor Location<sup>a</sup></u>		<u>Period</u>		
	Total	<u>Total Due To Modeled Sources</u>	<u>Background</u>	<u>Direction (°)</u>	<u>Distance (km)</u>	<u>Julian Day</u>	<u>Hour Ending</u>	<u>Year</u>
3-hour <sup>b</sup>	895	795	100	60	7.0	165	12	1982
24-hour <sup>b</sup>	254	226	28	60	7.2	165	24	1982
Annual	31	27	4	346	3.0	--	--	1984

Note: AAQS are 1,300 µg/m<sup>3</sup>, 3-hour  
260 µg/m<sup>3</sup>, 24-hour  
60 µg/m<sup>3</sup>, annual

<sup>a</sup>Relative to the location of the Sanford plant.

<sup>b</sup>Highest, second-highest concentrations predicted for this averaging period.

Table 3-6. Source Contributions to the Maximum SO<sub>2</sub> Concentrations  
Predicted in the Refined Analysis

Source	Concentration ( $\mu\text{g}/\text{m}^3$ )		
	Annual	24-hour	3-hour
Sanford	4.9	61.4	202.6
Turner	9.1	163.6	588.2
DeBary	7.3	0.4	4.3
OUC Stanton Energy Center	0.5	0.0	0.0
C.A. Meyer	0.2	0.2	0.0
New Smyrna Beach Utility	1.0	0.0	0.0
Martin Asphalt	<u>4.3</u>	<u>0.1</u>	<u>0.0</u>
Total	27.3	225.7	795.1

Table 3-7. Maximum Predicted SO<sub>2</sub> Concentrations From the Screening Analysis for Comparison to PSD Class II Increments

Averaging Period	Maximum Concentration (µg/m <sup>3</sup> )	Receptor Location <sup>a</sup>		Period		
		Direction (°)	Distance (km)	Julian Day	Hour Ending	Year
3-hour <sup>b</sup>	228	260	3.0	305	12	1982
	264	160	1.3	82	12	1983
	320	20	1.3	209	15	1984
	260	300	1.0	193	12	1985
	279	240	1.3	137	15	1986
24-hour <sup>b</sup>	45	260	4.0	305	24	1982
	44	300	4.0	130	24	1983
	54	230	1.3	82	24	1984
	55	200	1.3	148	24	1985
	51	300	3.0	273	24	1986
Annual	4.3	360	4.0	--	--	1982
	4.1	240	4.0	--	--	1983
	4.7	300	4.0	--	--	1984
	4.7	120	5.0	--	--	1985
	4.7	120	4.0	--	--	1986

<sup>a</sup>Relative to the location of the Sanford plant.

<sup>b</sup>Highest, second-highest concentrations predicted for this averaging period.

Table 3-8. Maximum Predicted SO<sub>2</sub> Concentrations From the Refined Analysis for Comparison to PSD Class II Increments

Averaging Period	Maximum Concentration ( $\mu\text{g}/\text{m}^3$ )	Receptor Location <sup>a</sup>		Period			PSD Class II Increment
		Direction (°)	Distance (km)	Julian Day	Hour Ending	Year	
3-Hour <sup>b</sup>	348	22	1.2	209	15	1984	512
24-Hour <sup>b</sup>	59	202	1.1	148	24	1985	91
Annual	4.8	126	4.4	-	-	1984	20

<sup>a</sup>Relative to the location of the Sanford plant.

<sup>b</sup>Highest, second-highest concentrations predicted for this averaging period.

Table 3-9. Comparison of Maximum SO<sub>2</sub> Predicted Impacts For Various Emission Strategies--Refined Analysis

Emission Scenario	Averaging Time	Year	Concentration (µg/m <sup>3</sup> )	Direction (°)	Distance (m)	Day	Hour Ending
Current Emissions: Units 3, 4, and 5 at 1.65 lb/10 <sup>6</sup> Btu	Annual	1984	6.3	240	3,700	-	-
	24-Hour	1985	85	202	1,100	148	-
	3-Hour	1984	484	20	1,100	209	15
Proposed Emissions: Units 3, 5, at 1.1 lb/10 <sup>6</sup> Btu, Unit 4 at 4.3 lb/10 <sup>6</sup> Btu	Annual	1984	7.5	240	4,300	-	-
	24-Hour	1985	115	202	1,100	148	-
	3-Hour	1984	667	22	1,200	209	15
Maximum PSD Increment Consumed from Current to Proposed Emission Scenario	Annual	1984	1.5	302	5,300	-	-
	24-Hour	1985	32	202	1,200	148	-
	3-Hour	1984	188	22	1,200	209	15

The maximum increments consumed in going from the current to proposed emission scenario are  $1.5 \mu\text{g}/\text{m}^3$  for annual averaging,  $32 \mu\text{g}/\text{m}^3$  for 24-hour averaging, and  $188 \mu\text{g}/\text{m}^3$  for 3-hour averaging. The allowable PSD increments are 20, 19, and  $512 \mu\text{g}/\text{m}^3$ , respectively.

### 3.5 CONCLUSIONS

The proposed Orimulsion test burn in Sanford Unit 4 will produce maximum predicted  $\text{SO}_2$  and PM concentrations that are expected to comply with the AAQS and PSD Class II increments. These results are based on PM emission rates for the proposed test burn that include excess emissions occurring for 3 hours during a 24-hour period at all three units.

For PM, the maximum concentration due to the test burn alone is predicted to be less than the significant impact levels. For  $\text{SO}_2$ , the maximum concentrations due to emissions from the Sanford plant and other sources are predicted to be below the AAQS and PSD Class II increments.

#### 4.0 ADDITIONAL IMPACT ANALYSIS

##### 4.1 IMPACTS ON VEGETATION

The response of vegetation to atmospheric pollutants is influenced by the concentration of the pollutant, duration of the exposure and the frequency of exposures. The pattern of pollutant exposure expected from the facility is that of a few episodes of relatively high ground-level concentration which occur during certain meteorological conditions interspersed with long periods of extremely low ground-level concentrations. If there are any effects of stack emissions on plants they will be from the short-term higher doses. A dose is the product of the concentration of the pollutant and the duration of the exposure. The impact of the Sanford Unit 4 test burn on regional vegetation was assessed by comparing pollutant doses that are predicted from modeling with threshold doses reported from the scientific literature which could adversely affect plant species typical of those present in the region.

##### 4.1.1 SULFUR DIOXIDE

The maximum total 3-hour average SO<sub>2</sub> concentration resulting from the test burn is predicted to be 448 µg/m<sup>3</sup> [348 µg/m<sup>3</sup> (Table 3-2) plus 100 µg/m<sup>3</sup> background]. This concentration is predicted to occur about 1.2 km (0.75 mile) north-northeast of the stacks and represents the concentration that would occur during the worst-case meteorological conditions of the past five years. The maximum 3-hour average ground-level concentration predicted for the other four years are 85 percent or less of the maximum concentration. Concentrations decrease with distance beyond the location of the maximum concentration.

The maximum total predicted 24-hour average SO<sub>2</sub> concentration resulting from the test burn is 87 µg/m<sup>3</sup> [59 µg/m<sup>3</sup> (Table 3-2) plus 28 µg/m<sup>3</sup> background] and is located approximately 1.1 km (0.70 mile) south-southeast of the stacks. The maximum total predicted annual SO<sub>2</sub> concentration is 7.4 µg/m<sup>3</sup> [3.4 µg/m<sup>3</sup> (Table 3-2) plus 4 µg/m<sup>3</sup> background]. This concentration is predicted to occur 4.9 km (3.1 miles) to the southwest of the stacks.

These concentrations and averaging times can be compared with SO<sub>2</sub> doses known to adversely affect plant species that are presented in Table 4-1. The expected doses from the test burn combined with background sources are much lower than doses known to cause a detrimental effect on vegetation.

#### 4.1.2 PARTICULATE MATTER--TSP AND PM10

Predicted impacts of these pollutants are less than the significant impact levels (see Table 3-3). As a result, no impacts are expected to occur to vegetation as a result of temporarily increasing PM/PM10 emissions.

#### 4.2 IMPACTS TO SOILS

SO<sub>2</sub> that reaches the soil by deposition from the air is converted by physical and biotic processes to sulfates. (Particulates have no affect on soils at the levels predicted.) The effects can be beneficial to plants if sulfates in native soils are less than plant requirements for optimum growth. However, sulfates can also increase acidity of unbuffered soils, causing adverse effects due to changes in nutrient availability and cycling. The predicted concentrations of SO<sub>2</sub> from stack emissions are not expected to have a significant adverse effect on soils in the vicinity because:

1. The predicted concentrations are low;
2. Fertilizer and ground limestone is generally applied to lands being used for crops, pasture, and citrus; and
3. Emissions of SO<sub>2</sub> from the proposed test burn are equivalent to or less than quantities previously emitted and permitted for.

Therefore, the facility is not expected to have a significant adverse impact on regional vegetation or soils.

#### 4.3 IMPACTS DUE TO ADDITIONAL GROWTH

A limited number of additional personnel will be temporarily added to the current plant personnel complement. These additional personnel are expected to have an insignificant effect on the residential, commercial, and industrial growth in Volusia County.



Table 4-1. SO<sub>2</sub> Doses Reported to Affect Plant Species Similar to Vegetation in the Region of the Sanford Plant

Pollutant	Species	Dose and Effect	Reference
SO <sub>2</sub>	Strawberry	1,040 µg/m <sup>3</sup> for 6 hours per day for 3 days had no affect on growth	Rajput <u>et al.</u> , 1977
SO <sub>2</sub>	Citrus	2,080 µg/m <sup>3</sup> for 23 days with 10 day interruption reduced leaf area	Matsushima and Brewer, 1972
SO <sub>2</sub>	Ryegrass	42 µg/m <sup>3</sup> for 26 weeks or 367 µg/m <sup>3</sup> for 131 days reduced dry weight	Bell <u>et al.</u> , 1979 Ayazaloo and Bell, 1981
SO <sub>2</sub>	Tomato	1,258 µg/m <sup>3</sup> for 5 hours per day, for 57 days, reduced growth	Kohut <u>et al.</u> , 1983
SO <sub>2</sub>	Duckweed	390 µg/m <sup>3</sup> for 6 weeks reduced growth	Fankhauser <u>et al.</u> , 1976
SO <sub>2</sub>	Lichens (Parmotrema and Ramalina spp.)	400 µg/m <sup>3</sup> 6 hours per week for 10 weeks reduced CO <sub>2</sub> uptake and biomass gain of <u>Ramalina</u> , not <u>Parmotrema</u>	Hart <u>et al.</u> , 1988
SO <sub>2</sub>	Bald Cypress	1,300 and 2,600 µg/m <sup>3</sup> for 48 hours. Only 2,600 µg/m <sup>3</sup> reduced leaf area.	Shanklin and Kozlowski, 1985
SO <sub>2</sub>	Green Ash	210 µg/m <sup>3</sup> for 4 hours per day, 5 days per week for 6 weeks reduced growth	Chappelka <u>et al.</u> , 1988

Orimulsion will be delivered by truck every week to the facility in the same manner as residual oil. As a result, no additional impacts will occur.

Therefore, no air quality related impacts associated with residential, commercial and industrial growth are anticipated.

#### 4.4 IMPACTS TO VISIBILITY

The Sanford Plant is located greater than 100 km from a Class I area; pursuant to Chapter 17-2.500(5)(d) i.e., F.A.C., a visibility impact analysis is not required.

REFERENCES

- Ayazaloo, M. and J. N. B. Bell. 1981. Studies on the tolerance to sulphur dioxide of grass populations in pollutant areas. I. Identification of tolerant populations. *New Phytologist* 88: 203-222.
- Bell, et al. 1979. Studies on the effects of low-levels of sulfur dioxide on the growth of Lolium perenne L. *New Phytologist* 83: 627-644.
- Chappelka, A.H.; B.I. Chevone, and T.E. Burk. 1988. Growth response of green and white ash seedlings to ozone, sulfur dioxide, and simulated acid rain. *Forest Science* 34: 1016-1029
- Fankhauser, H., C. Brunold, and K.H. Erismann. 1976. The influence of sublethal concentrations of sulfur dioxide on morphology, growth and product yield of the duckweed Lemna minor L. *Oecologia* 23: 201-209.
- Florida Department of Environmental Regulation (FDER). 1988. Ambient Air Monitoring Report--1988. Division of Air Resources Management. Tallahassee, FL.
- Hart, R., et al. 1988. The use of lichen fumigation studies to evaluate the effects of new emission sources on Class I areas. *Journal Air Pollution Control Association* 38: 144-147.
- Kohut, R. J. et al. 1983. The National Crop Loss Assessment Network: A Summary of Field Studies. Paper 82-69.5. Session 69. Presentation at the 75th Annual Meeting of the Air Pollution Control Association.
- Matsushima, J. and R. F. Brewer. 1972. Influence of sulfur dioxide and hydrogen fluoride as a mix or reciprocal exposure on citrus growth and development. *Journal Air Pollution Control Association* 22: 710-713.
- Rajput, C.B.S., D.P. Ormrod, and W.D. Evans. 1977. The resistance of strawberries to ozone and sulfur dioxide. *Plant Disease Reporter* 61: 222-225.
- Shanklin, J. and T. T. Kozlowski. 1985. Effect of flooding of soil on growth and subsequent responses of Taxodium distichum seedlings to SO<sub>2</sub>. *Environmental Pollution* 38: 199-212.
- U.S. Environmental Protection Agency (EPA). 1986. Guideline on Air Quality Models (Revised). EPA-450/2-78-027R. Office of Air Quality Planning and Standards. Research Triangle Park, NC.
- U.S. Environmental Protection Agency (EPA). 1987. Industrial Source Complex (ISC) Dispersion Model User's Guide--Second Edition (Revised). EPA-450/4-88-002a. Office of Air Quality Planning and Standards. Research Triangle Park, NC.

# HOPPING BOYD GREEN & SAMS

ATTORNEYS AND COUNSELORS

123 SOUTH CALHOUN STREET

POST OFFICE BOX 6526

TALLAHASSEE, FLORIDA 32314

(904) 222-7500

FAX (904) 224-8551

CARLOS ALVAREZ  
JAMES S. ALVES  
BRIAN H. BIBEAU  
ELIZABETH C. BOWMAN  
WILLIAM L. BOYD, IV  
RICHARD S. BRIGHTMAN  
PETER C. CUNNINGHAM  
WILLIAM H. GREEN  
WADE L. HOPPING  
FRANK E. MATTHEWS  
RICHARD D. MELSON  
WILLIAM D. PRESTON  
CAROLYN S. RAEPPLE  
GARY P. SAMS  
ROBERT P. SMITH, JR.

KATHLEEN BLIZZARD  
THOMAS M. DEBOSE  
RICHARD W. MOORE  
DIANA M. PARKER  
LAURA BOYD PEARCE  
MICHAEL P. PETROVICH  
DAVID L. POWELL  
DOUGLAS S. ROBERTS  
CECELIA C. SMITH  
SAM J. SMITH  
CHERYL G. STUART

## MEMORANDUM

April 2, 1990

OF COUNSEL

W. ROBERT FOKES

RE: RAMIFICATIONS OF NEW SOURCE PERFORMANCE STANDARDS  
(NSPS) AND PREVENTION OF SIGNIFICANT DETERIORATION  
(PSD) REGULATIONS ON THE PROPOSED ORIMULSION  
PROJECT

### BACKGROUND AND ASSUMED FACTS

Florida Power & Light Company (FPL) is proposing a test burn of an emulsified bitumen fuel, known as Orimulsion, at its Sanford Generating Unit #4. The test burn is part of a more than decade-long effort of FPL to expand its fuel base. This liquid fossil fuel is produced in Venezuela and is handled, stored, transported and burned like residual oil. In view of the vast Venezuelan reserves of the hydrocarbon from which Orimulsion can be produced, the fuel promises to substantially expand the energy base of FPL and potentially the United States. It has been estimated that these reserves may be the equivalent of one-half of the present coal reserves in the United States. The Venezuelan government is marketing Orimulsion at coal-equivalent prices.

FPL operates nine 400 MW generating units that use standard front wall-fired boilers and four 800 MW boilers that are scaled up versions of the 400 MW design. Tests of Orimulsion in the laboratory and in a full-scale demonstration project in Canada have indicated that Orimulsion can be utilized as a fuel in these FPL boilers with no change in boiler design. However, the addition of pollution control equipment would be necessary for a permanent fuel switch if increases in current stack emissions are to be avoided. FPL engineers have proposed a test burn of Orimulsion in order to confirm their projections, and to allow testing of various pollution control methods required to select and size the optimum

Memorandum  
April 2, 1990  
Page 2

control technology to be used with a permanent conversion. The proposed test burn can be carried out at Sanford Unit #4 without changes to the boiler. In fact, the only boiler auxiliaries that will need to be changed will be the burner guns and tips at a cost of approximately \$100,000, and the reinstallation of furnace wall blowers. Minimal new fuel handling equipment will be required because Orimulsion behaves essentially the same as the residual oil that the Plant has burned for years. Hot water heat exchangers, circulating hot water pumps, a hot water storage tank and an Orimulsion fuel flow meter will be added. Existing fuel storage tanks, burner feed pumps and tank vertical mixers will be used.

Sanford Unit #4 was designed to accommodate a range of solid, liquid and gaseous fuels. It was placed under construction prior to 1971 and originally brought on-line burning residual fuel oil. The unit was tested over a period of several months with a coal oil mixture (COM) in the early 1980's pursuant to EPA and DER approvals. At that time the agencies confirmed that Sanford Unit #4 was "designed-to-accommodate" coal because the combustion of coal could be accommodated without changes to the boiler. Boiler auxiliaries changed for the COM test included the burner guns, so that steam atomization could be used, and wall blowers to deal with greater ash production. However, the COM test did require the addition of major fuel related facilities at the site, including coal pulverization equipment, conveyors and other fuel handling facilities that did not previously exist. Consequently, EPA determined that a PSD permit was required for the test. The PSD permit did not impose new pollution control equipment to control boiler emissions, although particulate matter emissions and opacity were temporarily increased by the switch to COM.

In the early 1980's, FPL also evaluated the conversion to 100% coal-related fuels at its 400 MW and 800 MW units. EPA developed a policy in 1983 which concluded that such conversions would not trigger NSPS at coal capable boilers, but would trigger PSD review if coal handling equipment had to be added to the sites to allow coal use. (See Attachment 1). EPA's 1983 coal conversion policy also provided that a Best Available Control Technology (BACT) analysis was not required for boilers capable of firing coal, but that it would be required to control emissions from non-boiler related new equipment needed to handle and store coal.

DISCUSSION

FPL is committed, if the Orimulsion test burn proves successful from an operational and economic standpoint, to the installation of continuous emission reduction equipment that will achieve a decrease in current emissions of sulfur dioxide and particulate matter. This commitment will preclude the possibility that NSPS or PSD review will be required for these pollutants at that time. However, like COM, the combustion of Orimulsion at the Sanford facility for a test burn would be expected to temporarily increase emissions. Sulfur dioxide emissions will increase because of the higher sulfur content associated with Orimulsion fuel. Particulate matter and opacity emissions are expected to increase somewhat as well. In light of these temporary emissions increases, the question is raised whether the test would trigger NSPS for boiler emissions and whether the changes would trigger PSD review, potentially including Best Available Control Technology (BACT) requirements. An analysis of pertinent EPA and DER statutes, regulations and precedents follows:

NSPS: THE PROPOSED CHANGES WILL NOT TRIGGER THE APPLICABILITY OF NSPS.

NSPS emission limitations apply to new sources which commence construction on or after the date that applicable NSPS are proposed as well as to existing sources which undergo certain physical or operational changes that result in increased emissions. There are three sets of NSPS that require consideration with regard to the proposed Orimulsion test. These are found at 40 CFR, Part 60, Subpart D, Subpart Da, and Subpart Db.<sup>1/</sup> The applicability years of those standards are 1971, 1978 and 1984. The question is whether the physical and operational changes required to burn Orimulsion would trigger any of these NSPS requirements. The determinative provision of EPA regulations is found at 40 CFR, Section 60.14.<sup>2/</sup> That

---

<sup>1/</sup> Subparts D, Da and Db are incorporated by reference in DER Rule 17-2.660(2)(a), Table 660-1, F.A.C.  
(continued)

Memorandum  
April 2, 1990  
Page 4

section defines modifications that can cause existing sources to be deemed new sources, subject to NSPS. It also establishes certain exemptions from the modification provision, including a provision explicitly covering fuel-switches. In particular, a modification will not include:

Use of an alternative fuel or raw material if, prior to the date any standard under this part becomes applicable to that source type [1971, 1978 or 1984], ... the existing facility was designed to accommodate that alternative use. A facility shall be considered to be designed to accommodate an alternative fuel or raw material if that use could be accomplished under the facility's construction specifications as amended prior to the change... .

40 CFR, Section 60.14(e)(4). (Emphasis added)

The boiler manufacturer, Foster Wheeler Energy Corporation, has evaluated the characteristics of Orimulsion and determined that the original design envelope for the Sanford Unit #4 boiler will accommodate the combustion of Orimulsion with minimal changes (e.g. burners). (See Attachment 2).

The NSPS fuel-switch exemption has been construed and honored by EPA on numerous occasions. As noted earlier, the exemption was applied by EPA with regard to the COM test conducted at the facility in the early 1980's. That ruling was consistent with the later adopted 1983 coal conversion policy of EPA. As for the COM test, the Orimulsion test will involve the use of new burner guns with steam atomization and the use of wall blowers.<sup>3/</sup> Thus, under EPA

---

2/ Section 60.14 is incorporated by reference in DER Rule 17-2.660(3)(f), F.A.C.

3/ The addition of soot blowers has been held in other situations by EPA to be a minimal change not triggering NSPS requirements. For example, on March 28, 1973, EPA determined that the installation of soot blowers in a power (continued)

Memorandum  
April 2, 1990  
Page 5

NSPS regulations and associated EPA interpretations, the changes in boiler auxiliaries proposed for the Orimulsion project are not of sufficient magnitude to trigger the applicability of NSPS to the boiler emissions.

PSD: PSD REVIEW SHOULD NOT BE REQUIRED FOR THE ORIMULSION TEST BURN BECAUSE, UNLIKE THE COM AND COAL CONVERSION SITUATIONS, THE PLANTWIDE CHANGES NEEDED FOR THE FUEL SWITCH ARE MINIMAL. IN THE EVENT THAT PSD REVIEW IS DETERMINED TO BE APPLICABLE, BACT SHOULD NOT APPLY TO THE BOILER.

PSD review, like NSPS applicability, is ordinarily associated with the construction of new sources. However, certain modifications at existing sources can constitute "construction" which triggers PSD review and, potentially, the imposition of BACT requirements. The threshold test for determining whether an existing source will be modified for PSD purposes is whether non-exempted changes at the facility as a whole will result in a net emissions increase which exceeds significance levels established by agency regulations.<sup>4/</sup> We have assumed that the emissions increases associated with Orimulsion will be significant. The changes will be exempted if they involve the:

Use of an alternative fuel or raw material which the facility was capable of accommodating before January 6, 1975, unless such change would be prohibited under any federally enforceable permit condition established after January 6, 1975.

Rule 17-2.500(2)(c)4., F.A.C. (Emphasis added).<sup>5/</sup>

---

plant did not constitute a modification under 40 CFR, Part 60. (See Attachment 3).

<sup>4/</sup> Significant levels are listed in Rule 17-2.500(8), Table 500-2, F.A.C.

<sup>5/</sup> This rule has been approved by EPA.



Memorandum  
April 2, 1990  
Page 6

No federally enforceable permit condition precludes the use of Orimulsion. Therefore, the changes will not trigger PSD review if it is determined that the facility was "capable of accommodating" the Orimulsion fuel before January 6, 1975.

The "capable of accommodating" test examines the fuel switch capability of the entire facility rather than simply the boiler itself, which we have already concluded was designed to accommodate Orimulsion. Historically, EPA has denied the PSD fuel switch exemption where the facility involved did not have on-site all of the major fuel handling, storage and preparation facilities needed for the new fuel usage, even where the boiler involved qualified for the NSPS fuel switch exemption. It is for this reason that EPA concluded that the need to add coal pulverization and conveyance equipment for the COM test at Sanford Unit #4 triggered PSD review. The question for the proposed Orimulsion burn is whether the addition of heat exchangers, hot water pumps, a hot water storage tank, and a fuel flow meter would be deemed of sufficient import to negate the PSD exemption.

PSD review is a preconstruction permit program that applies to the "construction" of major sources. Section 169(1)(c) of the Clean Air Act defines the term "construction" as used in the PSD provisions of the Act as follows:

The term "construction", when used in connection with any source or facility, includes the modification (as defined in Section 111(a) of this Title) of any source or facility.

Section 111(a) referred to in this definition is the NSPS section of the Act. In essence, if an NSPS triggering modification results in a significant net increase in emissions from a "facility", then PSD will be required. If a modification is exempted from NSPS, then it can be argued that the emissions increases of the "source" (boiler) should not require PSD review. Accordingly, where the NSPS regulations which implement Section 111(a) have been construed to exempt changes from NSPS, PSD review should not apply to such changes.

Memorandum  
April 2, 1990  
Page 7

This interpretation is completely consistent with the coal conversion policy developed by EPA Region IV in 1983. That policy exempted boilers designed to accommodate an alternate fuel from BACT, as follows:

In the situation where the individual boiler being converted is capable of firing coal with minimal physical changes (for example, change of burners only) BACT analysis would apply to the coal handling and storage equipment as well as other necessary new equipment. BACT analysis would not apply to the boilers since, individually, they were designed to accommodate coal and therefore, will not be undergoing a physical change or change in the method of operation.<sup>6/</sup>

Early this year, EPA reconfirmed an NSPS/PSD determination for a proposed natural gas addition at a generating unit of Detroit Edison which was initially designed to fire either gas or oil. (See Attachment 4). The physical changes at the plant included the addition of equipment necessary to deliver gas to the existing boiler and several minor changes to the boiler including burner modifications. The determination reaffirmed the historical approach that EPA has followed when it applied the fuel switch exemptions of the NSPS and PSD regulations to utility boiler changes:

... [A]lthough the addition of gas firing would subject the source as a whole to a PSD review, the requirement to apply BACT is applicable only to those emissions units at the source which undergo both a physical or operational change and a significant net emissions increase. It appears that the only emissions unit at the Greenwood Plant affected by the proposal to fire gas would be the existing boiler. Historically, it has

---

6/ See Attachment 1.

Memorandum  
April 2, 1990  
Page 8

been EPA's policy that where the individual boiler being converted is capable of accommodating the alternate fuel, BACT would not apply.

Though EPA reserved judgement with regard to certain non-burner related changes, it concluded that burner modification would not subject the boiler to BACT review. The Detroit Edison determination supports the view that BACT should not apply to the Sanford Unit #4 boiler changes at hand.

Although the boiler-related changes such as burner changes and the addition of soot blowers (discussed earlier) clearly should be exempted from BACT review, the regulatory consequences of the addition of non-boiler related Orimulsion handling equipment is less clear. Our review of EPA precedent has disclosed an earlier determination that provides some guidance. In 1975, a paper mill in Michigan needed to add oil preheating equipment at two boilers that had previously burned natural gas and No. 2 oil, in order to allow the burning of No. 6 oil which has different heating requirements. EPA concluded that the installation of the No. 6 fuel oil firing equipment, including the oil preheating equipment, would not constitute a modification for NSPS purposes. See Attachment 5. Sanford Unit #4 currently burns No. 6 oil and would be fitted with equipment to optimize heating of Orimulsion, a similar fuel. It can thus be argued that the Orimulsion heating system should also be exempted from consideration under NSPS and PSD. The recent Detroit Edison ruling does require a PSD permit even when the boiler itself was exempted from NSPS and BACT; however, in that case, Detroit Edison did not have equipment to deliver gas to the combustion unit. In the case of Sanford Unit #4, existing equipment is available to deliver Orimulsion to the combustion unit, with only minor changes needed to better assure fuel stability during handling.

#### CONCLUSIONS

The Orimulsion test should not be deemed to trigger NSPS because Sanford Unit #4 is "designed to accommodate" the fuel. This is borne out by the absence of changes to the boiler itself, by the minimal changes in boiler auxiliaries

Memorandum  
April 2, 1990  
Page 9

needed to burn the fuel, by prior EPA precedent, and by the conclusions of the boiler manufacturer. EPA regulations and precedent clearly support the conclusion that a PSD/BACT analysis should not apply to boiler-related emissions resulting from an Orimulsion fuel switch at Sanford Unit #4.

PSD applicability to the project as a whole is less clear because of the non-boiler related changes needed to burn Orimulsion. An early EPA determination has held that the addition of fuel heating equipment at boilers to allow the burning of a different grade of oil would not be deemed a modification for NSPS purposes; therefore, one can argue that the simple addition of fuel heating equipment at Sanford Unit #4 should not be deemed to constitute a modification for PSD purpose. The recent Detroit Edison decision focused on the absence of any alternate fuel delivery equipment at the site, which is not the case at Sanford Unit #4. In effect, there is ample room for a favorable agency interpretation on this point.

WHG/wrn  
4/2/90:1:50 p.m.

Best Available Copy.

**Burns & McDonnell** / Engineers - Architects - Consultants  
POST OFFICE BOX 173  
KANSAS CITY, MISSOURI 64141  
TEL. 513-241-2475 TOL. 513-771-8059  
4000 EAST 63RD STREET

March 16, 1973

Director  
Division of Stationary Source Enforcement  
Environmental Protection Agency  
NSM - Room 3220  
Washington, D.C. 20460

Subject: Determination  
Addition Soot Blowers  
Carl E. Bailey Generating Station  
Arkansas Electric Cooperative Corporation

Dear Sir:

We were referred to your office by the Kansas City Regional Office of the United States Environmental Protection Agency for a determination. Our client, Arkansas Electric Cooperative Corporation, Little Rock, Arkansas, proposes to install soot blowers at their existing Carl E. Bailey Electric Generating Station at Augusta, Arkansas. The question has arisen as to whether the installation of these soot blowers is included within the applicability of Environmental Protection Regulations on Standards of Performance for New Stationary Sources as set forth in 40 CFR 60; 36 FR 2476, issued December 23, 1971, effective August, 1971. The section that applies in this case is as follows:

Part 60-3 The definition of modification, as it pertains to increases in production rate and changes of fuel, has been clarified. Increases in production rates up to design capacity will not be considered a modification nor will fuel switches if the equipment was originally designed to accommodate such fuels. These provisions will eliminate inequities where equipment had been put into partial operation prior to the proposal of the standards.

The Carl E. Bailey Electric Generating Station, owned and operated by the Arkansas Electric Cooperative Corporation, is a natural gas and No. 6 oil-fired steam electric generating station with a capacity at peak rating of approximately 125 megawatts. The power generating station feeds electric power into transmission systems which serve several states.

The steam generator was designed to burn both natural gas and No. 6 oil. Due to the availability of natural gas, the soot blowers were not installed with the boiler. The boiler was provided with wall boxes, so that when fuel oil was burned on a continuous basis and soot blowers were needed, the pressure parts of the boiler would not have to be disturbed.

2671 S.W. 27th AVENUE, MIAMI, FLORIDA 33133  
TWO PENNSYLVANIA PLAZA, NEW YORK, NEW YORK 10001  
1500 SOUTH EAST FIRST AVENUE, PORTLAND, OREGON 97201

Director, Division of Stationary Source Enforcement  
March 16, 1973  
Page No. 2

Additional provisions made for soot blowers were the extra weight of steel required to support the future extended soot blower platforms. Construction was begun at the station site early in 1964, and the station went on the line in January, 1966. Due to curtailment of natural gas over the following years, more No. 6 oil had to be burned each succeeding year. Now it appears it must be burned continuously and soot blowers must be added.

The addition of soot blowers optimizes boiler performance only. There is no increase in production rates nor do they increase the total pollutants going into the air. Further, the equipment was designed to burn No. 6 fuel oil, and also burned it prior to the date any standards became effective. Consequently, it is our feeling the determination should indicate that standards of performance for new stationary sources are not applicable and that the addition of soot blowers is not a modification.

Sincerely,

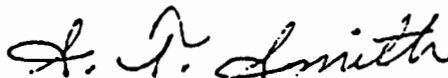

S. T. Smith, P.E.  
Chief Engineer  
Environmental Division

STS:sf

cc: Arliss Wright



UNITED STATES ENVIRONMENTAL PROTECTION AGENCY  
Office of Air Quality Planning and Standards  
Research Triangle Park, North Carolina 27711

M. STERLING

JAN 22 1990

JAN 18 1990

Mr. Morton Sterling, Director  
Environmental Protection  
Detroit Edison Company  
200 Second Avenue, 482 WCB  
Detroit, Michigan 48226

Dear Mr. Sterling:

This is a followup to the October 19, 1989 meeting during which Detroit Edison further discussed its position that the addition of natural gas firing capacity to the Greenwood Unit I Power Plant should not be subject to a prevention of significant deterioration (PSD) review. At the meeting, you requested that Environmental Protection Agency (EPA) Headquarters review Region V's previous determination that the proposed fuel conversion was a "major modification" for PSD purposes.

As you are aware, in a letter dated December 20, 1988, EPA Region V concluded that the proposed conversion of the oil-fired Greenwood Unit to dual capacity for oil and gas firing would subject the plant to a PSD review for nitrogen oxides (NO<sub>x</sub>). The Region's conclusion was based on a determination that 1) the source was not capable of firing natural gas prior to January 6, 1975 (and therefore was not covered by the PSD exemption for modifications under 40 CFR 52.21(b)(2)(iii)(e)(1)); and 2) there would be a significant net increase of NO<sub>x</sub> resulting from the change. As you have requested, we have reevaluated this finding in light of the additional information submitted by Detroit Edison during the October 19 meeting.

The information presented by Detroit Edison indicates that the emissions unit at the source was initially designed and permitted to fire both oil and gas. However, there is no evidence to demonstrate that the source as a whole had, or at any time initiated construction on, the equipment necessary to deliver natural gas to the combustion unit. Without such equipment, it would not be possible for the source to utilize natural gas as an alternate fuel. Consequently, it is our view that the source was not capable of accommodating natural gas prior to January 6, 1975. Therefore, the changes necessary to accommodate the firing of natural gas at the Greenwood Plant would, for PSD purposes, be considered a "physical change" to the source.

As requested, we have also evaluated the net emissions change at the source that would result from the modification. It is Detroit Edison's position that the large decreases in "allowable" emissions of sulfur dioxide, particulate matter, and NO<sub>x</sub> when burning natural gas rather than oil as a result of the modification, warrants special consideration. Specifically, Detroit Edison feels that the use of a cleaner fuel at the Greenwood Plant warrants a finding that there is no increase in actual emissions and accordingly no "major modification."

Under the PSD regulation, a "major modification" occurs when the physical or operational change at the source (in this case the installation of natural gas handling facilities and the firing of natural gas) would result in a significant net emissions increase for any regulated pollutant at the source. Whether the proposed use of natural gas at the Greenwood Plant would result in a "significant net emissions increase" depends on a comparison between the "actual emissions" before and after the physical or operational change. Where, as here, the source has not yet begun operations firing natural gas, "actual emissions" after the change to natural gas firing are deemed to be the source's "potential to emit" for that fuel [see 40 CFR 52.21(b)(21)(iv)]. Potential annual NO<sub>x</sub> emissions when firing natural gas at the Greenwood Plant greatly exceed its current actual emissions. Therefore, as a result of the ability to fire natural gas after the change, the emissions of NO<sub>x</sub> at the source would experience a "significant net emissions increase," within the meaning of the PSD regulations. The fact that current annual "allowable emissions" for the Greenwood Plant when firing oil may greatly exceed future allowable (or potential) emissions when firing natural gas is not relevant for PSD applicability purposes. See Puerto Rican Cement Co., Inc. v. EPA No.89-1070 (First Circuit) (slip op. October 31, 1989).

In summary, our review indicates that Region V correctly applied the PSD applicability criteria.

The PSD requirements include an air quality and additional impact analysis and the application of best available control technology (BACT). The BACT requirement applies to "each proposed emissions unit at which a net emissions increase would occur as a result of a physical change or change in the method of operation in the unit" [see 52.21(j)(3)]. Consequently, although the addition of gas firing would subject the source as a whole to a PSD review, the requirement to apply BACT is applicable only to those emissions units at the source which undergo both a physical or operational change and a significant net emissions increase. It appears that the only emissions unit at the Greenwood Plant affected by the proposal to fire gas would be the existing boiler. Historically, it has been EPA's policy that where the individual boiler being converted is capable of accommodating the alternate fuel, BACT would not apply.

In this case, in addition to the physical changes at the source necessary to deliver natural gas to the existing boiler, a number of canes capable of burning natural gas would be installed in the existing burner assemblies. Modifications to the unit's overfired air duct are also planned. We also understand that there will be no changes in the present oil burning system, which will be retained.

Our review indicates that, by itself, the addition of gas canes to the burners is not a physical change or change in the method of operation in the unit and, consequently, would not subject the boiler to a BACT review. Therefore, if the sole change to the boiler is the addition of the canes, then, in this case, the only requirements necessary for a PSD permit are an air quality analysis, additional impacts analyses, and (if applicable) a Class I impact analysis--the application of BACT is not required. However,



3

the information submitted by Detroit Edison indicates that changes to the boiler's overfired air duct are also planned. At this time, without additional information on the nature and scope of the work to be done on the overfired air duct, we cannot determine whether these are physical or operational changes to the boiler that are necessary to make the boiler capable of accommodating natural gas. If the ducting work is necessary for this purpose, then a BACT analysis would likely be required.

In addition, it is unclear from the information submitted whether Detroit Edison plans to undertake further modifications to the boiler which would allow 100 percent load when firing natural gas. Currently, the unit as presently configured has the potential of achieving only 75 percent load when firing natural gas. To achieve a higher load, substantial modifications to the unit apparently would be required. These types of physical changes to the boiler likely would require a full PSD review, including a BACT analysis for the boiler. The BACT analysis would require that the source evaluate the use of all available additional air pollution controls for reducing NO<sub>x</sub> emissions. The analysis would consider retrofit costs for add-on controls and the fact that gas is a relatively clean-burning fuel. Consequently, in this case, it is possible that the currently planned use of a low-NO<sub>x</sub> burner design may be BACT for gas firing. However, such a conclusion would have to be demonstrated through the requisite BACT analysis. I have asked Region V to work with you should you need assistance in preparing the analysis.

Sincerely,

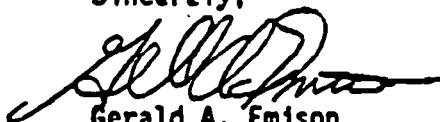

Gerald A. Emison  
Director  
Office of Air Quality Planning  
and Standards

cc: J. Calcagni, EPA/AQMD  
D. Kee, EPA/Region V  
G. Foote, EPA/OGC

Determination of Applicability of New Source  
Performance Standards (NSPS)

AUG 5 1975

James O. McDonald, Director  
Enforcement Division

Richard D. Wilson, Director  
Division of Stationary Source Enforcement

The Escanaba (Michigan) Paper Mill Division of the Mead Corporation received State permits for the installation of oil pre-heating equipment and new nozzles on two boilers which burned natural gas or Number 2 fuel oil prior to August 17, 1971, to make it possible for them to burn Number 6 fuel oil as well.

Does the installation of the Number 6 fuel oil-firing equipment constitute a modification as defined by NSPS, or does the use of Number 6 fuel oil fall within the exemption provided in paragraph H(2)(iii) of Section 60.2?

ORIGINAL SIGNED BY JAMES O. McDONALD

James O. McDonald

1  
AUG 19 1975

MEMORANDUM

SUBJECT: Determination of Applicability of Subpart D (NSPS) to Escanaba Paper Mill Division of the Mead Corporation

FROM: Director, Division of Stationary Source Enforcement

TO: James O. McDonald, Director  
Enforcement Division, Region V

In response to your request of August 5, 1975, we have determined that the proposed change to the existing boilers at the Escanaba Paper Mill does not constitute a modification under NSPS since such change fall within the exemption of §60.2(h)(2)(iii).

Richard D. Wilson

AGGS:GeorgeStevens:bm:8-18-75

D-2

JUN 7 1983

44V-AN

Mr. Steve Smallwood, Chief  
Bureau of Air Quality Management  
Twin Towers Office Building  
2600 Blair Stone Road  
Tallahassee, Florida 32301

Dear Mr. Smallwood:

This is to inform you of Region IV policy concerning applicability of coal conversions to EPA PSD regulations.

Fuel conversions, in general, are considered major modifications for purposes of PSD review providing emission increases are significant. However, Section 52.21(b)(2)(iii)(e) provides an exemption for certain fuel conversions from the major modification definition. Specifically, this section exempts a fuel conversion from PSD review if the source was capable of accommodating the alternate fuel before January 6, 1975 and such a change is not prohibited by any enforceable permit conditions.

The question then, is whether the source, i.e., the entire plant, was capable of accommodating coal before January 6, 1975. For purposes of converting one or more, but not all of the boilers, we interpret this provision as requiring that the plant be capable of receiving, transferring, and preparing coal, and then transferring coal and combusting coal in the units being converted, and disposing of the ash. It is not necessary for the plant to be capable of carrying out all those operations for every unit at the source, but only for those being converted. On the other hand, if the plant is capable of receiving coal and transferring and combusting it only in some other unit at the plant, but not the one being converted, the plant would not be deemed capable of accommodating coal for purposes of that project.

In order for a plant to be capable of accommodating coal, the company must show not only that the design (i.e., construction specifications) for the source contemplated the equipment, but also that the equipment actually was installed and still remains in existence. Otherwise, it cannot reasonably be concluded that the use of coal was "designed into the source." Thus, a source that had used coal at a particular unit at an earlier time, but later switched to another fuel, would be capable of accommodating coal as long as the coal handling equipment still existed. If coal handling equipment had been removed or was never installed, the source would not be coal accommodative. If a proposed conversion is not eligible for the exemption under 52.21(b)(2)(iii)(e), it is considered a major modification for the purposes of PSD review if the resulting net emission increases are significant. PSD applicability would be based on all emission increases from the conversion, including emission increases from the coal and ash handling and storage facilities as well as from the boilers, since all the increases are caused by the conversion to coal.

Once PSD applicability has been established, it is then necessary to undertake a BACT analysis as required under 52.21(j). That section, under paragraph 3, requires that a major modification apply "best available control technology for each pollutant subject to regulation under the Act for which it would result in a significant net emissions increase at the source. This requirement applies to each proposed emissions unit at which a net emissions increase in the pollutant would occur as a result of a physical change or change in the method of operation in the unit." This section clearly intends that technology review be assessed on an emissions unit rather than on a plant-wide basis.

In the situation where the individual boiler being converted is capable of firing coal with minimal physical changes (for example, change of burners only), BACT analysis would apply to the coal handling and storage equipment as well as any other necessary new equipment. BACT analysis would not apply to the boilers since individually they were designed to accommodate coal and therefore will not be undergoing a physical change or change in the method of operation.

In addition to the BACT analysis, requirements for a source impact analysis (52.21(k)), air quality analysis (52.21(m)), additional impact analyses (52.21(o)), and Class I analysis (52.21(p)) must be satisfied.

Once the source has satisfied these requirements and the notice and public comment provisions, permit approval may proceed.

Region IV is aware that guidance on this question has been somewhat vague, and possibly conflicting, in the past. Therefore, we do not intend for this policy to be applied retroactively where it was not adhered to. However, we do expect each Region IV state to immediately implement this policy for all future applicability determinations.

Sincerely yours,

James T. Wilburn, Chief  
Air Management Branch  
Air & Waste Management Division

cc: Ed Reich  
Darryl Tyler



# FOSTER WHEELER ENERGY CORPORATION

PERRYVILLE CORPORATE PARK • CLINTON, NEW JERSEY 08809-4000 • PHONE 201-730-4000

ADDRESS REPLY TO

107 E. Linden Avenue, Suite 400  
Clinton Park, Florida 32789  
Phone 407-740-0607 Telex 513255

December 13, 1989

Florida Power & Light Co.  
P.O. Box 078768  
West Palm Beach, Florida 33407-0768

Attention: Mr. D.L. Christian  
Project Manager

Subject: Orimulsion Test Burn

Dear Mr. Christian:

The Sanford Units were originally designed to burn #6 fuel oil with provisions for coal firing. Foster Wheeler has previously engineered and proposed firing coal-oil mixture, (COM) coal-water fuel, (CWF) and pulverized coal (P.C.) in these units, indicating the wide range of acceptable fuels.

A review of the specification and description of Orimulsion, reveals that this fuel has properties similar to the fuels cited above, which are within the design capabilities of the unit.

Specifically, the following comparisons can be made:

- 1) Viscosity - Similar in range and rheology to CWF, this is more burner related than boiler related.
- 2) Heat Content - The Orimulsion heating value of 12,733 BTU/LB is similar to pulverized coal and higher than CWF. It is lower than COM, and therefore within the range of fuels already demonstrated as useable in the Sanford Units.
- 3) The input would be similar to that for CWF in that the moisture contents are comparable.
- 4) The unit efficiency with Orimulsion should be higher than CWF by virtue of the HHV, but lower than P.C. due to the moisture.
- 5) The ash impact of Orimulsion should be less than the coal based fuels - P.C., COM, and CWF. The elemental analysis for this Bitumin based fuel is analagous to coal. The Vanadium is similar to a high Vanadium crude.

Orimulsion Test Burn  
December 13, 1989

In summary, the Sanford boilers were originally designed with an operational envelope that would accommodate the combustion of a variety of fuels within specific ranges of moisture content, ash constituents, heat content, etc. Since the properties of orimulsion fall within their design envelope, the firing of orimulsion would be expected to require no boiler modifications beyond those minimal changes required for combustion of any fuel of similar characteristics.

Should further information be required, please do not hesitate to contact us.

Very truly yours,  
Foster Wheeler Energy Corp.

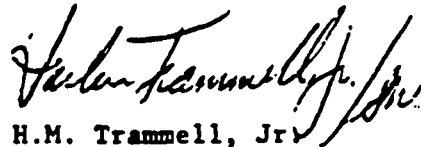
  
H.M. Trammell, Jr.  
Regional Vice President

HMT/GTN/va

Best Available Copy  
ENVIRONMENTAL PROTECTION AGENCY

March 28, 1973

D-3

S. T. Smith, P.E.  
Chief Engineer  
Burns & McDonnell  
Post Office Box 175  
Kansas City, Missouri 64141

Dear Sir:

Please be advised that pursuant to 40 CFR 60.5 it is our determination that the installation of soot blowers to the Carl T. Miller Electric Generating Station at Augusta, Arkansas does not constitute a "modification" as defined in 40 CFR 60.2(b), and, therefore, does not bring you within the scope of applicability of the New Source Performance Standards, 40 CFR 60.

Such determination, however, in no way relieves you of any requirements under State law. You should check with the Arkansas Department of Pollution Control and Ecology for the applicable State requirements and to determine whether the installation of soot blowers, or fuel switching from natural gas to No. 6 oil constitutes a modification within the meaning of State new source review provisions. In those States where EPA has promulgated a new source review provisions of the State implementation plans, (this does not include Arkansas), fuel switching does constitute a "modification". The stricter definition in these implementation plans is required in order to meet and maintain the National Ambient Air Quality Standards.

Sincerely yours,

Peter M. Yoell  
Attorney-Advisor  
DOSE

AGGS:P. Yoell/mas/3/28/73

CONCURRENCE

DATE							
NAME							
INITIALS							

OPTIONAL FIELD COPY