



TAMPA ELECTRIC

# POLK POWER STATION UNIT 6

RECEIVED

SEP 11 2007

AIR CONSTRUCTION/  
PREVENTION OF SIGNIFICANT  
DETERIORATION PERMIT  
APPLICATION

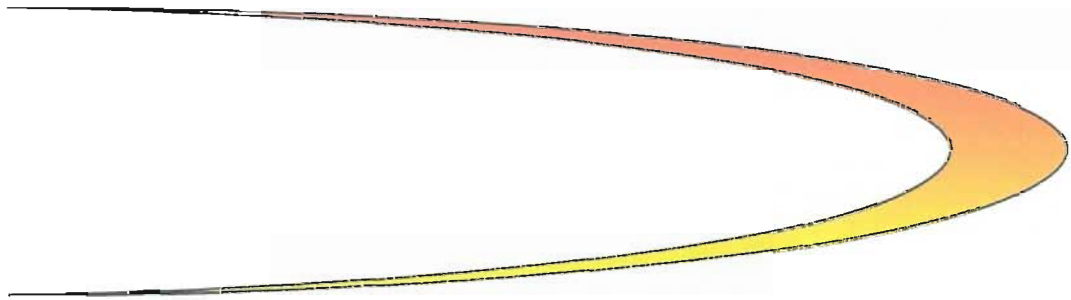

Prepared by:

**ECT**

Environmental Consulting & Technology, Inc.  
3701 Northwest 98<sup>th</sup> Street  
Gainesville, Florida 32606  
ECT No. 070040-0100

September 2007

## TABLE OF CONTENTS

<u>Section</u>		<u>Page</u>
1.0	INTRODUCTION AND SUMMARY	1-1
1.1	<u>INTRODUCTION</u>	1-1
1.2	<u>SUMMARY</u>	1-4
2.0	PROJECT DESCRIPTION	2-1
2.1	<u>PROJECT LOCATION, AREA MAP, AND PLOT PLAN</u>	2-1
2.2	<u>PROJECT FUELS</u>	2-3
2.2.1	FUEL QUALITY AND QUANTITY	2-8
2.3	<u>PROJECT DESCRIPTION AND FLOW DIAGRAM</u>	2-11
2.3.1	SOLID FUEL RECEIVING, STORAGE, PREPARATION, AND HANDLING	2-16
2.3.2	GASIFICATION PROCESS	2-19
2.3.3	COMBINED-CYCLE PROCESS	2-20
2.4	<u>EMISSIONS AND STACK PARAMETERS</u>	2-21
3.0	NEW SOURCE REVIEW REQUIREMENTS	3-1
3.1	<u>NATIONAL AND STATE AAQS</u>	3-1
3.2	<u>NONATTAINMENT NSR APPLICABILITY</u>	3-3
3.3	<u>PSD NSR APPLICABILITY</u>	3-3
3.4	<u>PSD REQUIREMENTS</u>	3-3
3.4.1	CONTROL TECHNOLOGY REVIEW	3-3
3.4.2	AMBIENT AIR QUALITY MONITORING	3-7
3.4.3	AMBIENT IMPACT ANALYSIS	3-8
3.4.4	ADDITIONAL IMPACT ANALYSES	3-15
3.5	<u>HAZARDOUS AIR POLLUTANT REQUIREMENTS</u>	3-16
4.0	STATE AND FEDERAL EMISSION STANDARDS	4-1
4.1	<u>NEW SOURCE PERFORMANCE STANDARDS (NSPS)</u>	4-1
4.1.1	NSPS SUBPART DA—ELECTRIC STEAM GENERATING UNITS	4-1

TABLE OF CONTENTS  
(Continued, Page 2 of 6)

<u>Section</u>		<u>Page</u>
4.1.2	NSPS SUBPART <b>DB</b> —INDUSTRIAL-COMMERCIAL-INSTITUTIONAL STEAM GENERATING UNITS	4-3
4.1.3	NSPS SUBPART H—SULFURIC ACID PLANTS	4-3
4.1.4	NSPS SUBPART Y—COAL PREPARATION PLANTS	4-4
4.1.5	NSPS SUBPART HHHH—EMISSION GUIDELINES AND COMPLIANCE TIMES FOR COAL-FIRED ELECTRIC STEAM GENERATING UNITS	4-5
4.1.6	NSPS SUBPART IIII – STATIONARY COMPRESSION IGNITION INTERNAL COMBUSTION ENGINES	4-5
4.1.7	NSPS SUBPART KKKK—STATIONARY COMBUSTION TURBINES	4-6
4.2	<u>NATIONAL EMISSION STANDARDS FOR HAZARDOUS AIR POLLUTANTS (NESHAPS)</u>	4-7
4.3	<u>ACID RAIN PROGRAM</u>	4-8
4.4	<u>CLEAN AIR INTERSTATE RULE</u>	4-9
4.5	<u>CLEAN AIR MERCURY RULE</u>	4-11
4.6	<u>FLORIDA EMISSION STANDARDS</u>	4-13
5.0	BEST AVAILABLE CONTROL TECHNOLOGY	5-1
5.1	<u>METHODOLOGY</u>	5-1
5.2	<u>EVALUATION OF ALTERNATIVE ELECTRICAL GENERATION TECHNOLOGIES</u>	5-4
5.3	<u>BACT ANALYSIS FOR NO<sub>x</sub></u>	5-4
5.3.1	CT/HRSG	5-4
5.3.1.1	<u>Available NO<sub>x</sub> Control Technologies</u>	5-6
5.3.1.2	<u>Technical Feasibility and Ranking</u>	5-14
5.3.1.3	<u>Evaluation of Control Technologies</u>	5-16
5.3.1.4	<u>Proposed NO<sub>x</sub> BACT</u>	5-19
5.3.2	AUXILIARY BOILER	5-31

TABLE OF CONTENTS  
(Continued, Page 3 of 6)

<u>Section</u>	<u>Page</u>
5.3.2.1 <u>Available NO<sub>x</sub> Control Technologies</u>	5-31
5.3.2.2 <u>Technical Feasibility and Ranking</u>	5-32
5.3.2.3 <u>Proposed NO<sub>x</sub> BACT</u>	5-32
5.3.3 EMERGENCY DIESEL ENGINES	5-33
5.3.3.1 <u>Proposed NO<sub>x</sub> BACT</u>	5-35
<b>5.4 <u>BACT ANALYSIS FOR SO<sub>2</sub> AND H<sub>2</sub>SO<sub>4</sub> MIST</u></b>	<b>5-35</b>
5.4.1 CT/HRSG	5-35
5.4.1.1 <u>Available SO<sub>2</sub> and H<sub>2</sub>SO<sub>4</sub> Mist Control Technologies</u>	5-35
5.4.1.2 <u>Technical Feasibility and Ranking</u>	5-37
5.4.1.3 <u>Evaluation of Control Technologies</u>	5-37
5.4.1.4 <u>Proposed SO<sub>2</sub> and H<sub>2</sub>SO<sub>4</sub> Mist BACT</u>	5-38
5.4.2 AUXILIARY BOILER	5-48
5.4.3 EMERGENCY DIESEL ENGINES	5-49
5.4.4 SULFURIC ACID PLANT	5-49
5.4.4.1 <u>Available SO<sub>2</sub> and H<sub>2</sub>SO<sub>4</sub> Mist Control Technologies</u>	5-50
5.4.4.2 <u>Technical Feasibility and Rankings</u>	5-50
5.4.4.3 <u>Evaluation of Control Technologies</u>	5-50
5.4.4.4 <u>Proposed SO<sub>2</sub> and H<sub>2</sub>SO<sub>4</sub> Mist BACT</u>	5-51
<b>5.5 <u>BACT ANALYSIS FOR CO</u></b>	<b>5-51</b>
5.5.1 CT/HRSG	5-51
5.5.1.1 <u>Available CO Control Technologies</u>	5-51
5.5.1.2 <u>Technical Feasibility</u>	5-54
5.5.1.3 <u>Proposed CO BACT</u>	5-57
5.5.2 AUXILIARY BOILER	5-62
5.5.3 EMERGENCY DIESEL ENGINES	5-63

TABLE OF CONTENTS  
(Continued, Page 4 of 6)

<u>Section</u>		<u>Page</u>
5.6	<u>BACT ANALYSIS FOR PM/PM<sub>10</sub></u>	5-64
5.6.1	CT/HRSG	5-65
5.6.1.1	<u>Available PM/PM<sub>10</sub> Control Technologies</u>	5-65
5.6.1.2	<u>Technical Feasibility and Ranking</u>	5-67
5.6.1.3	<u>Evaluation of Control Technologies</u>	5-67
5.6.1.4	<u>Proposed PM/PM<sub>10</sub> BACT</u>	5-67
5.6.2	AUXILIARY BOILER	5-73
5.6.3	EMERGENCY DIESEL ENGINES	5-73
5.6.4	COOLING TOWER	5-74
5.6.4.1	<u>Dry Cooling</u>	5-74
5.6.4.2	<u>Wet Cooling</u>	5-75
5.6.4.3	<u>Available PM/PM<sub>10</sub> Control Technologies</u>	5-75
5.6.4.4	<u>Proposed PM/PM<sub>10</sub> BACT</u>	5-76
5.6.5	MATERIAL HANDLING	5-76
5.6.5.1	<u>Available PM/PM<sub>10</sub> Control Technologies</u>	5-77
5.6.5.2	<u>Proposed PM/PM<sub>10</sub> BACT</u>	5-78
5.7	<u>SUMMARY OF PROPOSED BACT</u>	5-78
6.0	AIR QUALITY IMPACT ANALYSIS METHODOLOGY	6-1
6.1	<u>GENERAL APPROACH</u>	6-1
6.2	<u>POLLUTANTS EVALUATED</u>	6-1
6.3	<u>MODEL SELECTION AND USE</u>	6-2
6.4	<u>MODEL OPTIONS</u>	6-3
6.5	<u>NO<sub>2</sub> AMBIENT IMPACT ANALYSIS</u>	6-3
6.6	<u>TERRAIN CONSIDERATION</u>	6-3
6.7	<u>BUILDING WAKE EFFECTS</u>	6-4
6.8	<u>RECEPTOR GRIDS</u>	6-8
6.9	<u>METEOROLOGICAL DATA</u>	6-8
6.10	<u>MODELED EMISSION INVENTORY</u>	6-17
6.10.1	ON-PROPERTY SOURCES	6-17
6.10.2	OFF-PROPERTY SOURCES	6-20

TABLE OF CONTENTS  
(Continued, Page 5 of 6)

<u>Section</u>		<u>Page</u>
7.0	AMBIENT IMPACT ANALYSIS RESULTS	7-1
7.1	<u>OVERVIEW</u>	7-1
7.2	<u>PSD SIL ANALYSIS RESULTS</u>	7-2
7.3	<u>OZONE IMPACTS</u>	7-9
7.4	<u>AIR TOXICS MODELING RESULTS</u>	7-10
7.5	<u>MERCURY IMPACTS</u>	7-10
8.0	AMBIENT AIR QUALITY MONITORING AND ANALYSIS	8-1
8.1	<u>EXISTING AMBIENT AIR QUALITY MONITORING DATA</u>	8-1
8.2	<u>PRECONSTRUCTION AMBIENT AIR QUALITY MONITORING EXEMPTION APPLICABILITY</u>	8-1
8.2.1	PM <sub>10</sub>	8-7
8.2.2	SO <sub>2</sub>	8-7
8.2.3	NO <sub>2</sub>	8-7
8.2.4	CO	8-7
8.2.5	OZONE	8-8
9.0	ADDITIONAL IMPACT ANALYSIS	9-1
9.1	<u>GROWTH IMPACTS ANALYSIS</u>	9-1
9.1.1	PROJECT GROWTH IMPACTS	9-1
9.1.2	AREA GROWTH SINCE 1977	9-1
9.2	<u>IMPACTS ON SOILS, VEGETATION, AND WILDLIFE</u>	9-2
9.2.1	GENERAL AIR EMISSIONS IMPACTS ON SOILS	9-5
9.2.2	GENERAL AIR EMISSIONS IMPACTS ON VEGETATION	9-6
9.2.3	GENERAL AIR EMISSIONS IMPACTS ON WILDLIFE	9-13
9.2.4	SPECIFIC AIR EMISSIONS IMPACTS IN THE VICINITY OF UNIT 6	9-13
9.2.5	SPECIFIC AIR EMISSIONS IMPACTS—CLASS I AREAS	9-13
9.3	<u>VISIBILITY IMPAIRMENT POTENTIAL</u>	9-13

TABLE OF CONTENTS  
(Continued, Page 6 of 6)

<u>Section</u>	<u>Page</u>
APPENDICES	
APPENDIX A—EMISSION RATE CALCULATIONS	
APPENDIX B—FDEP AIR PERMIT APPLICATION FORM	
APPENDIX C—DISPERSION MODELING FILES	
APPENDIX D—ANALYSIS OF CLASS II METEOROLOGICAL DATA	

## LIST OF TABLES

<u>Table</u>		<u>Page</u>
2-1	Polk Unit 6 Building and Structure Dimensions	2-6
2-2	Design Properties for Coal, Petcoke, and Normal Operating Case Blend	2-9
2-3	Design Quantities of Solid Fuel Feedstock at Full Load	2-10
2-4	Typical Natural Gas Composition	2-12
2-5	Typical ULSD Composition	2-13
2-6	CT/HRSG—Criteria Pollutant Emission Rates (per CT)	2-24
2-7	CT/HRSG—H <sub>2</sub> SO <sub>4</sub> Mist, Mercury, Ammonia, and Carbon Dioxide Emission Rates (per CT)	2-25
2-8	Auxiliary Boiler—Criteria Pollutant Emission Rates	2-26
2-9	Firewater Pump Diesel Engines—Criteria Pollutant Emission Rates	2-28
2-10	Emergency Generator Diesel Engine—Criteria Pollutant Emission Rates	2-29
2-11	Polk Unit 6 Annual Emission Rate Summary	2-30
2-12	Stack Parameters	2-31
3-1	National and Florida Air Quality Standards	3-2
3-2	Projected Unit 6 Emissions Compared to PSD Significant Emission Rates	3-4
3-3	PSD <i>De Minimis</i> Ambient Impact Levels	3-9
3-4	FDEP Significant Impact Levels	3-10
3-5	EPA Significant Impact Levels—Class I Areas	3-11
3-6	PSD Allowable Increments	3-14
5-1a	Ranking of Available NO <sub>x</sub> Control Technologies CT/HRSG—Syngas	5-17



LIST OF TABLES  
(Continued, Page 2 of 3)

<u>Table</u>		<u>Page</u>
5-1b	Ranking of Available NO <sub>x</sub> Control Technologies CT/HRSG— Natural Gas	5-18
5-2	NO <sub>x</sub> BACT Summary of IGCC Projects—Syngas Firing	5-20
5-3	NO <sub>x</sub> BACT Summary of IGCC Projects—Natural Gas Firing	5-21
5-4	Summary of PC Boiler NO <sub>x</sub> BACT Determinations	5-29
5-5	Recent BACT Determinations for Natural Gas-Fired Auxiliary Boilers	5-34
5-6	SO <sub>2</sub> BACT Summary of IGCC Projects—Syngas Firing	5-40
5-7	SO <sub>2</sub> BACT Summary of IGCC Projects—Natural Gas Firing	5-41
5-8	H <sub>2</sub> SO <sub>4</sub> Mist BACT Summary of IGCC Projects—Syngas Firing	5-42
5-9	H <sub>2</sub> SO <sub>4</sub> Mist BACT Summary of IGCC Projects—Natural Gas Firing	5-43
5-10	Summary of Coal-Fired Power Plant SO <sub>2</sub> BACT Determinations	5-44
5-11	Summary of Coal-Fired Power Plant H <sub>2</sub> SO <sub>4</sub> Mist BACT Determinations	5-46
5-12	Recent BACT Determinations for H <sub>2</sub> SO <sub>4</sub> Plants	5-52
5-13	CO BACT Summary of IGCC Projects—Syngas Firing	5-58
5-14	CO BACT Summary of IGCC Projects—Natural Gas Firing	5-59
5-15	CO BACT Determinations—Bituminous Pulverized Coal-Fired Plants	5-60
5-16	PM BACT Summary of IGCC Projects—Syngas Firing	5-69
5-17	PM BACT Summary of IGCC Projects—Natural Gas Firing	5-70
5-18	Summary of Coal-Fired Power Plant PM BACT Determinations	5-71
5-19	Summary of Proposed BACT	5-79
6-1	Dimensions of Unit 6 Major Buildings and Structures	6-6

LIST OF TABLES  
(Continued, Page 3 of 3)

<u>Table</u>		<u>Page</u>
6-2	Summary of AERMET Surface Characteristics	6-18
6-3	Percent Differences in AERMET Surface Characteristics	6-19
7-1	Unit 6—Class II NO <sub>2</sub> Impacts	7-3
7-2	Unit 6—Class II SO <sub>2</sub> Impacts	7-4
7-3	Unit 6—Class II PM <sub>10</sub> Impacts	7-6
7-4	Unit 6—Class II CO Impacts	7-7
7-5	Unit 6—Summary of Class II Impacts	7-8
7-6	Unit 6—Summary of Air Toxic Impacts	7-11
7-7	Unit 6 Mercury Deposition and Concentration Impacts	7-13
8-1	Polk County Area Ambient Air Quality Data 2002 through 2006 Data for PM <sub>10</sub> , PM <sub>2.5</sub> , SO <sub>2</sub> , NO <sub>2</sub> , CO, and Lead	8-2
8-2	Polk County Area Ambient Air Quality Data 2002 through 2006 Data for Ozone	8-5
9-1	Unit 6 Maximum Pollutant Concentration Impacts	9-3
9-2	Projected Maximum Annual Wet and Dry Atmospheric Deposition Impacts	9-4
9-3	Estimated Maximum Facility Impacts Compared to General Plant Injury Symptoms and Threshold Concentrations for Important Air Pollutants	9-7
9-4	Air Pollutant Injury Threshold Concentrations for Plants Native to the Southeast	9-8
9-5	Examples of Reported Stresses to Animals at Air Pollutant Concentrations Below National Secondary Ambient Air Quality Standards	9-13
9-6	Soil pHs for the Soils Found in the Chassahowitzka NWA	9-13
9-7	Chemical Properties of the Soils within the Chassahowitzka NWA	9-13

## LIST OF FIGURES

<u>Figure</u>		<u>Page</u>
2-1	Overall Site Layout or Eastern Portion of PPS Site	2-2
2-2	Detailed Layout of Existing and Proposed Polk Unit 6 Facilities	2-4
2-3	Detailed Layout of Facilities on Aerial Photograph	2-5
2-4	Preliminary Block Flow Diagram for Polk Unit 6 Project	2-15
2-5	Unit 6—Location of Air Emission Sources	2-23
6-1	Unit 6 Three-Dimensional View	6-7
6-2	Unit 6 Fenceline Receptors	6-9
6-3	Unit 6 Near- and Mid-Field Receptor Grids	6-10
6-4	Unit 6 Far-Field Receptor Grid	6-11
6-5	Wind Rose for Winter Haven Gilbert Airport (2003 and 2004)	6-13
6-6	Wind Rose for Tampa International Airport (2003 and 2004)	6-14
6-7	Wind Rose for Orlando International Airport (2003 and 2004)	6-16
9-1	NADP Annual Wet Deposition Values and 3-Year Weighted Average Trendline for Nitrate Within the Chassahowitzka NWA	9-13
9-2	NADP Wet Deposition Values and 3-Year Weighted Average Trendline for SO <sub>3</sub> Nitrate Within the Chassahowitzka NWA	9-13

## 1.0 INTRODUCTION AND SUMMARY

### 1.1 INTRODUCTION

Tampa Electric Company (Tampa Electric) plans to construct, own, and operate a nominal 630-megawatt (MW) (net), 790-MW (gross) integrated gasification combined-cycle (IGCC) electric generating unit and associated facilities, including state-of-the-art syngas treatment systems. The IGCC facility, referred to as Polk Unit 6, will be located at Tampa Electric's existing Polk Power Station (PPS) situated in southwest Polk County approximately 13 miles southwest of the city of Bartow.

Major components of Polk Unit 6 include gasifier feedstock (coal, petroleum code [pet-coke], and biomass) unloading, transfer, conveying, and preparation equipment; two oxygen-blown entrained flow gasification trains; two combined-cycle combustion turbine (CT)/heat recovery steam generator (HRSG) units; one common steam turbine; sulfuric acid plant, and a 10-cell mechanical draft cooling tower. The Unit 6 gasification trains will include comprehensive synthesis gas (syngas) cleanup systems comprised of multi-stage water scrubbing (for particulate matter [PM] and acid gas removal), carbonyl sulfide (COS) hydrolysis and Selexol™ physical absorption (for sulfur removal), and carbon adsorption beds (for mercury removal). Ancillary equipment associated with Unit 6 includes a flare (used during gasifier startups, shutdowns, and process upsets), natural gas-fired auxiliary boiler (used during gasifier startups), diesel engine-driven emergency generator, and two firewater pumps each fired with ultra-low sulfur diesel (ULSD) fuel oil; fire protection system; administration building; various maintenance and equipment storage warehouses; electrical interconnection facilities; and other balance-of-plant systems and equipment.

A key factor in Tampa Electric's decision to select the IGCC technology to meet its future power needs is the flexibility in fuel options that can be used by the technology. Such fuel flexibility will enable Tampa Electric to take full advantage of competitive fuel pricing and availability opportunities and transportation options in the future marketplace to provide low-cost, reliable electricity to its customers. Therefore, the proposed Polk Unit 6 Project has been designed to be capable of using a variety of solid fuels, such as

coal, petcoke, coal/petcoke blends, and other solid fuels such as biomass, as well as natural gas as backup fuel. Polk Unit 6 has been designed to be capable of using these primary solid fuels at ratios ranging from 100 percent coal to 100 percent petcoke and various coal/petcoke blends in between. Unit 6 will also be capable of using small quantities (e.g., up to 5 percent) of other fuels, such as biomass, in blends with the primary coal and petcoke fuels.

The principal Unit 6 emission sources are the two CT/HRSG units. Emissions from the CT/HRSGs comprise 90 percent of total estimated Unit 6 project annual criteria emissions. Emissions from the CT/HRSG units will be controlled using best available control technologies (BACT). Proposed BACT control technologies include:

- Good combustion practice to minimize the formation of carbon monoxide (CO) and volatile organic compounds (VOCs).
- Use of low-ash, low-sulfur syngas and natural gas for control of PM/particulate matter less than or equal to 10 microns (PM<sub>10</sub>), sulfur dioxide (SO<sub>2</sub>), and sulfuric acid (H<sub>2</sub>SO<sub>4</sub>) mist emissions.
- Syngas moisture saturation, nitrogen diluent, and selective catalytic reduction (SCR) technology for nitrogen oxides (NO<sub>x</sub>) control.

Operation of the proposed Unit 6 will result in airborne emissions. Therefore, a permit is required prior to the beginning of facility construction, per Rule 62-212.300(1)(a), Florida Administrative Code (F.A.C.). This submittal, including the required permit application forms and supporting documentation included in the appendices, constitutes Tampa Electric's application for authorization to commence construction in accordance with the Florida Department of Environmental Protection (FDEP) permitting rules contained in Chapter 62-212, *et. seq.*, F.A.C.

Under federal Prevention of Significant Deterioration (PSD) review requirements, all major new or modified sources of air pollutants regulated under the Clean Air Act (CAA) must be reviewed and approved by the U.S. Environmental Protection Agency (EPA) or by the state agency if PSD review authority has been delegated. A *major stationary source* is defined as any 1 of 28 named source categories that have the potential to emit

100 tons per year (tpy) or more, or any other stationary source that has the potential to emit 250 tpy or more, of any pollutant regulated under the CAA. *Potential to emit* means the capability at maximum design capacity to emit a pollutant after the application of control equipment. The existing PPS is an existing major stationary source since it falls into one of the named source categories and has the potential to emit 100 tpy of at least one regulated pollutant.

Unit 6 will be located at the existing PPS. Unit 6 will have potential emissions greater than one or more of the PSD significant emission rates listed in Rule 62-212.200(278), F.A.C. Accordingly, Unit 6 constitutes a *major modification* to an existing major source and is subject to the PSD New Source Review (NSR) requirements of Section 62-212.400, F.A.C., for those pollutants that are emitted at or over the specified PSD significant emission rate levels. Therefore, this report and application is also submitted to satisfy the permitting requirements contained in the FDEP PSD rules and regulations.

This report is organized as follows:

- Section 1.2 provides an overview and summary of the key regulatory determinations.
- Section 2.0 describes the proposed facility and associated air emissions.
- Section 3.0 describes the NSR requirements and discusses applicability of these requirements to the proposed project.
- Section 4.0 describes the applicable state and federal emission standards.
- Section 5.0 provides an analysis of BACT.
- Sections 6.0 (Dispersion Modeling Methodology) and 7.0 (Dispersion Modeling Results) address ambient air quality impacts (AAQS).
- Section 8.0 discusses current ambient air quality in the vicinity of the Project and preconstruction ambient air quality monitoring.
- Section 9.0 addresses other potential air quality impact analyses.
- Section 10.0 provides an assessment of impacts on Class I areas located within 300 kilometers (km) of the project site.

Appendices A and B provide emission rate calculations and the FDEP Application for Air Permit—Long Form, respectively. All dispersion modeling input and output files for the ambient impact analyses are provided in Appendix C. Information regarding the meteorological data selected for the Class II air quality impacts is provided in Appendix D.

## 1.2 SUMMARY

The primary source of emissions from the Unit 6 Project will result from the combustion of syngas in the two CT/HRSG units and production of H<sub>2</sub>SO<sub>4</sub> byproduct. Emissions from the CT/HRSG units comprise 90 percent of total estimated Unit 6 annual emissions. Principal air contaminants that will be emitted from the CT/HRSG units include NO<sub>x</sub>, SO<sub>2</sub>, CO, VOC, PM/PM<sub>10</sub>, and H<sub>2</sub>SO<sub>4</sub> mist. The CT/HRSG units will also emit trace amounts of metallic and organic compounds. The sulfuric acid plant will emit SO<sub>2</sub> and H<sub>2</sub>SO<sub>4</sub> mist. Ancillary Unit 6 emission sources include gasifier feedstock (coal, petcoke, and biomass) unloading, transfer, conveying, and preparation equipment; an auxiliary boiler; mechanical draft cooling tower; emergency generator diesel engine; and two emergency firewater pump diesel engines.

The planned Unit 6 construction is scheduled to start in early 2009 with initial operation planned for January 2013.

Based on an evaluation of anticipated worst-case annual operating scenarios, Unit 6 will have the potential to emit 925 tpy of NO<sub>x</sub>, 910 tpy of CO, 211 tpy of PM (filterable), 368 tpy of PM<sub>10</sub> (filterable and condensable), 670 tpy of SO<sub>2</sub>, 38 tpy of VOCs, 0.11 tpy of lead, 0.027 tpy of mercury, 0.6 tpy of total fluorides, and 123 tpy of H<sub>2</sub>SO<sub>4</sub>. Based on these potential annual emission rates, NO<sub>x</sub>, CO, PM/PM<sub>10</sub>, SO<sub>2</sub>, and H<sub>2</sub>SO<sub>4</sub> mist emissions are subject to PSD review.

The analyses required for this permit application have resulted in the following conclusions. Since the primary Unit 6 emission sources are the two CT/HRSG units, the conclusions primarily address these emission units.

- Syngas moisture saturation, nitrogen diluent, and SCR represent BACT for NO<sub>x</sub> when firing syngas. Steam injection and SCR represent NO<sub>x</sub> BACT

when firing natural gas. Although SCR has not been demonstrated on any existing coal-derived IGCC plant anywhere in the world, Tampa Electric proposes to install SCR on the Unit 6 CT/HRSG units. Proposed BACT NO<sub>x</sub> emission limits are 99 pounds per hour (lb/hr) (when firing syngas) and 33 lb/hr (when firing natural gas) on a 30-day rolling average basis for each CT/HRSG unit. For syngas-firing, the proposed BACT NO<sub>x</sub> emission limits are equivalent to 9.0 parts per million by volume dry (ppmvd) corrected to 15-percent oxygen, 0.24 pound per megawatt-hour (lb/MWh) (gross), and 0.032 pound per million British thermal units (lb/MMBtu) (gasifier heat input basis). For natural gas-firing, the proposed BACT NO<sub>x</sub> emission limit is equivalent to 5.0 ppmvd at 15-percent oxygen and 0.018 lb/MMBtu (CT heat input basis).

- The NO<sub>x</sub> emission limit proposed as BACT for Unit 6 when firing syngas, equivalent to 0.032 lb/MMBtu, is well below the rates recently proposed for state-of-the-art pulverized coal (PC) projects. For example, the Taylor Energy Center project planned for a site in Taylor County, Florida, proposed a NO<sub>x</sub> BACT limit of 0.05 lb/MMBtu, roughly 1.5 times higher than the limit proposed for Unit 6.
- Use of low-sulfur syngas and natural gas represent BACT for SO<sub>2</sub> and H<sub>2</sub>SO<sub>4</sub> mist. The syngas clean up system will include COS hydrolysis and Selexol™ physical absorption to reduce the syngas sulfur content. Proposed BACT SO<sub>2</sub> emission limits are 52 lb/hr (when firing syngas) on a 30-day rolling average basis, and use of pipeline quality natural gas containing no more than 2.0 grains of sulfur per one hundred standard cubic feet (gr S/100 scf) (when firing natural gas) for each CT/HRSG unit. For syngas-firing, the proposed BACT SO<sub>2</sub> emission limit is equivalent to 3.4 ppmvd at 15-percent oxygen, 0.13 lb/MWh (gross), and 0.017 lb/MMBtu (gasifier heat input basis).
- The SO<sub>2</sub> emission limit proposed as BACT for Unit 6 when firing syngas, equivalent to 0.017 lb/MMBtu, is well below the rates recently proposed for state-of-the-art PC projects. The Taylor Energy Center project proposed a



SO<sub>2</sub> BACT limit of 0.04 lb/MMBtu, roughly 2.5 times higher than the limit proposed for Unit 6.

- Dual absorption contact or wet sulfuric acid H<sub>2</sub>SO<sub>4</sub> technology and mist eliminators represent BACT for SO<sub>2</sub> and H<sub>2</sub>SO<sub>4</sub> mist for the sulfuric acid plant. Proposed BACT SO<sub>2</sub> and a H<sub>2</sub>SO<sub>4</sub> mist emission rates are 36.7 and 3.7 lb/hr, respectively. These emission limits are equivalent to an SO<sub>2</sub> emission rate of 1.0 pound per ton (lb/ton) of 100-percent acid produced, and an H<sub>2</sub>SO<sub>4</sub> emission rate of 0.10 lb/ton of 100-percent acid produced. This is consistent with the lowest H<sub>2</sub>SO<sub>4</sub> mist emission rates for recent BACT determinations for sulfuric acid plants and significantly lower than the top case for SO<sub>2</sub>.
- Good combustion design and operation represent BACT for CO. CT combustion design and operation requires a balancing of the competing goals to minimize the formation of both NO<sub>x</sub> and CO. The proposed CO BACT emission limits are 94 lb/hr (when firing syngas) and 81 lb/hr (when firing natural gas) on a 24-hour rolling average basis for each CT/HRSG unit. For syngas-firing, the proposed CO BACT emission limit is equivalent to 14 ppmvd at 15-percent oxygen, 0.23 lb/MWh (gross), and 0.030 lb/MMBtu (gasifier heat input basis). For natural gas-firing, the proposed CO BACT emission limit is equivalent to 20 ppmvd at 15-percent oxygen, and 0.045 lb/MMBtu (CT heat input basis).
- Use of low-ash syngas and natural gas represent BACT for PM (filterable) and PM<sub>10</sub> (filterable and condensable). Proposed total (filterable and condensable) PM/PM<sub>10</sub> BACT emission limits are 39 lb/hr on a 3-hour average basis (when firing syngas) and use of pipeline quality natural gas containing no more than 2.0 gr S/100 scf (when firing natural gas). For syngas-firing, the proposed PM/PM<sub>10</sub> BACT emission limit is equivalent to 0.096 lb/MWh (gross) and 0.013 lb/MMBtu (gasifier heat input basis).
- Water or chemical dust suppression, enclosure, and fabric filter technology will be used to control PM/PM<sub>10</sub> emission from the gasifier feedstock unloading, transfer, conveying, and preparation equipment. The mechanical

draft cooling tower will employ high efficiency drift eliminators to achieve a drift loss rate of no more than 0.0005 percent of the cooling tower recirculating water flow.

- Unit 6 is projected to emit NO<sub>x</sub>, PM<sub>10</sub>, SO<sub>2</sub>, and CO in greater than significant amounts. The ambient impact analysis demonstrates that Project impacts will be below the PSD *de minimis* monitoring significance levels for these pollutants. Accordingly, Unit 6 qualifies for the Rule 62-212.400(3)(e), F.A.C., exemption from PSD preconstruction ambient air quality monitoring for all PSD pollutants.
- The ambient impact analysis demonstrates that Unit 6 impacts will be below the PSD Class II significant impact levels defined in Rule 62-210.200(278), F.A.C., for all modeled PSD pollutants and averaging periods. Accordingly, a multisource cumulative assessment of national ambient air quality standards (NAAQS) attainment and PSD Class II increment consumption was not required.
- Class I areas located within 300 km of Unit 6 include the Chassahowitzka National Wilderness Area (NWA) and Everglades National Park (NP) in Florida. Assessments of PSD Class I increment and air quality-related values (AQRVs) (sulfur and nitrogen deposition and visibility) were conducted for each of these Class I areas.
- The ambient impact analysis demonstrates that project impacts will be below the EPA proposed PSD Class I significant impact levels for all Class I areas evaluated. Accordingly, a multisource cumulative assessment of PSD Class I increment consumption was not required.
- The analyses of PSD Class I area AQRVs indicates that Unit 6 impacts will be below levels that are detrimental to soils and vegetation and will not impair visibility.
- Based on refined dispersion modeling, Unit 6 will not cause nor contribute to an exceedance of any NAAQS, Florida AAQS, or PSD increment for Class I or Class II areas.



## 2.0 PROJECT DESCRIPTION

### 2.1 PROJECT LOCATION, AREA MAP, AND PLOT PLAN

The currently certified PPS Site consists of approximately 4,348 acres in southwest Polk County. Prior to development of the existing PPS facilities, the Site consisted primarily of previously mined phosphate lands which have subsequently been reclaimed and released under applicable FDEP and Polk County reclamation requirements. The portion of the Site containing the existing PPS power plant facilities is unmined lands, except for the approximately 755-acre cooling reservoir which was developed in a previously water-filled mine cut area. Tampa Electric is currently in the process of donating the approximately 1,511-acre portion of the Site on the west side of State Road (SR) 37 to Polk County as a wildlife management/recreation area in the near future. When this donation occurs, Tampa Electric will request that the existing certification for the PPS Site be amended to remove this portion from the certified Site area. No existing power plant facilities are currently located and no proposed facilities for the proposed Unit 6 Project will be located on this western portion of the PPS Site. Therefore, the Site description and analyses for the proposed Unit 6 Project focus on the approximately 2,837-acre portion of the PPS Site on the east side of SR 37.

Figure 2-1 presents the overall layout of the existing facilities (shown in red) and proposed new facilities for the Polk Unit 6 Project (shown in yellow) on the eastern portion of the Site on an aerial photograph with the Site boundaries delineated based on the upcoming land donation to Polk County. As shown in this figure, the proposed facilities for the proposed Unit 6 Project will be located on the unmined portion of the Site adjacent to the existing PPS facilities. This area of the Site currently consists of grass, pasture, and uplands. Only the new rail spur from the CSX railroad line along County Road (CR) 630 (Fort Green Road) will be constructed in a previously mined area which contains some areas of wetlands.



  
**GRAPHIC SCALE**  
 0      300      600  
  
 SCALE IN FEET

**LEGEND**



 EXISTING POLK UNITS 1 - 5 FACILITIES  
 NEW POLK UNIT 6 FACILITIES

FIGURE 2-1.  
 OVERALL SITE LAYOUT OR EASTERN PORTION OF PPS SITE

Sources: 2006 SWFWMD Aerials; Bechtel, 2007; ECT, 2007.



Figure 2-2 provides a more detailed layout of the existing and proposed facilities for the Polk Unit 6 Project and Figure 2-3 presents the similar detailed facility layout on a recent (i.e., 2006) aerial photograph. As shown in these figures, the proposed Unit 6 powerblock and major associated gasification, air separation unit, sulfuric acid plant, water treatment, and syngas treatment systems will be constructed to the south of the existing PPS facilities. A new rail loop and solid fuel unloading, storage, and fuel blending facilities will be to the west of the existing PPS facilities. A rail loop for fuel delivery was previously indicated in the original certification for the PPS Site; however, these facilities were not constructed and all solid fuel delivery for the existing Unit 1 IGCC plant have been provided by truck deliveries. The proposed new rail delivery facilities, which will be integrated with the existing truck delivery facilities, will allow for the delivery of coal and petcoke fuels for both the existing Unit 1 and proposed Unit 6 by rail or truck. As shown in Figure 2-2 and 2-3, the new mechanical draft cooling tower to provide for noncondenser cooling for both Units 1 and 6 and the new flare for the proposed Unit 6 will be located to the east of the new facilities. Construction laydown and parking areas will be temporarily provided in the upland areas south of the proposed Polk Unit 6 facilities.

Table 2-1 provides the approximate dimensions of the major buildings and facilities for the proposed Polk Unit 6 Project. As shown in this table, the tallest new structures will be the two gasifier structures at approximately 280 feet (ft) above ground level. The main exhaust stacks for the two HRSGs will be approximately 175 ft in height. The tallest existing structure on the PPS Site is the gasifier at approximately 250 ft in height.

## **2.2 PROJECT FUELS**

A key factor in Tampa Electric's decision to select the IGCC technology to meet its future power needs is the flexibility in fuel options which can be utilized in the technology. Such fuel flexibility will enable Tampa Electric to take full advantage of competitive fuel pricing and availability opportunities and transportation options in the future marketplace



- EXISTING FACILITY LEGEND**
- ① GASIFICATION
  - ② ACID GAS REMOVAL
  - ③ AIR SEPARATION UNIT
  - ④ SULFURIC ACID
  - ⑤ HOT GAS CLEAN-UP
  - ⑥ MAKE-UP WATER TREATING
  - ⑦ CONTROL AND GENERAL SERVICES BUILDING
  - ⑧ COAL GRINDING
  - ⑨ CONSTRUCTION POWER FACILITIES
  - ⑩ L.W.T. FACILITY AND HOLDING BASIN
  - ⑪ SANITARY WASTE TREATMENT
  - ⑫ 48V BATTERY, PBX AND RTU
  - ⑬ WAREHOUSE
  - ⑭ MAINT. SHOP
  - ⑮ NOT USED
  - ⑯ INSTR. AIR/PLANT AIR
  - ⑰ FUTURE FUEL CELL
  - ⑱ COAL UNLOADING
  - ⑲ BRINE CONCENTRATION
  - ⑳ PROPANE UNLOADING
  - ㉑ FUEL OIL STORAGE
  - ㉒ SLAG HANDLING

- NEW FACILITY LEGEND**
- ㉓ TRAIN UNLOADER
  - ㉔ FUEL UNLOADING RAIL LOOP
  - ㉕ ACTIVE FUEL PILE
  - ㉖ EMERGENCY STACK OUT
  - ㉗ STACK OUT CONVEYOR
  - ㉘ RECLAIM CONVEYOR
  - ㉙ COAL STORAGE #1
  - ㉚ COAL STORAGE #2
  - ㉛ COKE STORAGE
  - ㉜ FLUX UNLOADER
  - ㉝ FLUXANT STORAGE
  - ㉞ BELT TO UNIT #1 TRUCK UNLOADER
  - ㉟ BLENDING STATION TRANSFER POINT
  - ㊱ UNIT #6 BLENDING TRANSFER STATION
  - ㊲ UNIT #6 TRANSFER TOWER
  - ㊳ COOLING WATER DISCHARGE STRUCTURE
  - ㊴ AIR SEPARATION UNIT
  - ㊵ DEMINERALIZED WATER
  - ㊶ COOLING WATER INTAKE STRUCTURE
  - ㊷ GREY WATER BLOWDOWN WATER TREATMENT
  - ㊸ SULFURIC ACID PLANT
  - ㊹ CO2 COMPRESSOR
  - ㊺ GASIFICATION
  - ㊻ COAL GRINDING & SLURRY PREPARATION
  - ㊼ ACID GAS REMOVAL UNIT
  - ㊽ POWER BLOCK
  - ㊾ FINES HANDLING
  - ㊿ FIREWATER PUMP HOUSE
  - Ⓚ NOT USED
  - Ⓛ SLAG BINS
  - Ⓜ INSTR. AIR PLANT AIR
  - Ⓨ COOLING TOWER
  - Ⓩ EMERGENCY RECLAIM
  - ⓐ RECLAIM TRANSFER TOWER
  - ⓑ UNIT #1 BLENDING TRANSFER STATION
  - ⓒ INACTIVE COAL PILE
  - ⓓ FUEL UNLOADING TRANSFER TOWER
  - ⓔ FLARE
  - ⓕ BIOMASS STORAGE FUTURE
  - ⓖ EXISTING POLK FACILITIES
  - ⓗ PROPOSED POLK UNIT 6 FACILITIES

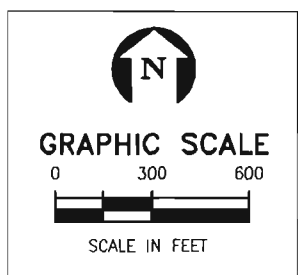
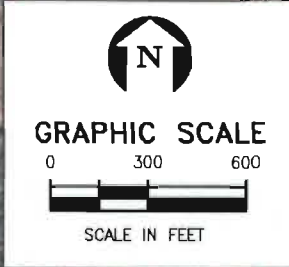
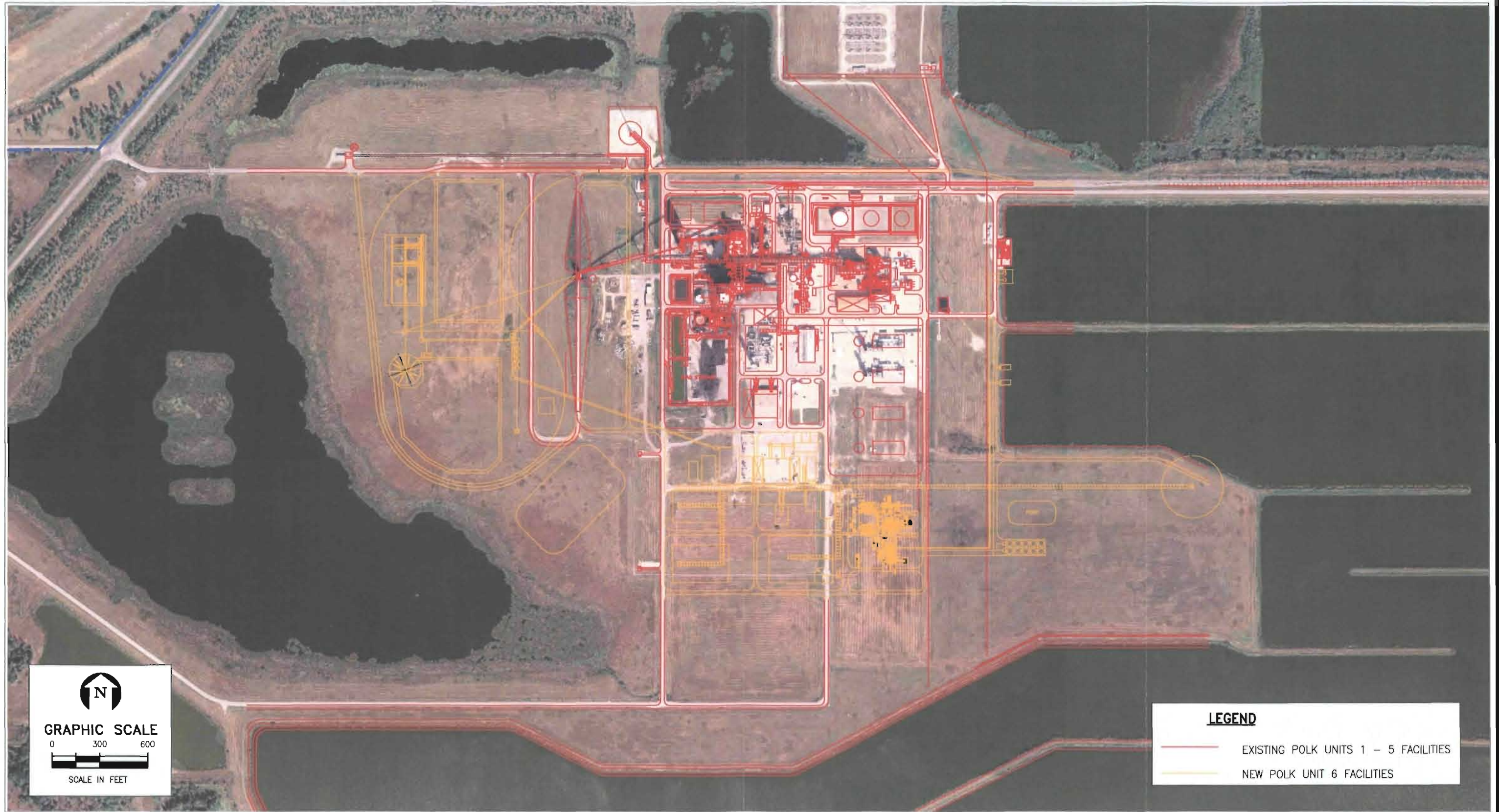

FIGURE 2-2.  
DETAILED LAYOUT OF EXISTING AND PROPOSED POLK UNIT 6 FACILITIES

Sources: Bechtel, 2007; ECT, 2007.





**LEGEND**



	EXISTING POLK UNITS 1 - 5 FACILITIES
	NEW POLK UNIT 6 FACILITIES

FIGURE 2-3.  
DETAILED LAYOUT OF FACILITIES ON AERIAL PHOTOGRAPH

Sources: 2006 SWFWMD Aerials; Bechtel, 2007; ECT, 2007.



Table 2-1. Polk Unit 6 Building and Structure Dimensions

Building/Structure	Height (ft)	Length (ft)	Width (ft)
Active coal pile	65	350	175
Inactive coal pile (north)	110	900	430
Inactive coal pile (south)	110	700	640
Emergency stack-out pile*	60	200	
Fuel blending silos	60	160	35
Coal grinding/slurry building	120	240	125
Air separation unit cold box*	175	35	
Slag stack-out area	20	150	120
Auxiliary boiler	50	150	75
Gasifiers	280	165	165
HRSB 1 and 2 trains (each)	100	98	32
Steam turbine generator	94	200	84
Cooling tower	42	250	100

\*Length dimension represents structure diameter.

Sources: Bechtel, 2007.  
ECT, 2007.



to provide low cost, reliable electricity to its customers. Therefore, the proposed Polk Unit 6 Project has been designed to be capable of using a variety of solid fuels, such as coal, petcoke, coal/petcoke blends, and other solid fuels such as biomass, as well as natural gas as backup fuel. This fuel flexibility will allow for solid fuels to be obtained from various regional locations in the United States, as well as from international sources; thus increasing the overall reliability of the fuel supply for the Project. Also, based on the PPS Site location in proximity to Tampa Bay and existing fuel delivery infrastructure at Tampa Electric's existing Big Bend Station and PPS, various transportation options are available to provide for competitive fuel delivery pricing for the Project. These transportation options include railroad, waterborne, and trucking. In addition, Polk Unit 6 has been designed to be capable of using natural gas as backup fuel which further enhances the unit's fuel flexibility and supply reliability.

Tampa Electric has extensive experience in the evaluation of options and cost-competitively sourcing coal and petcoke fuels for its solid-fueled generating units. For the Polk Unit 6, Tampa Electric has determined that bituminous coal from the Northern and Central Appalachian and Illinois Basin regions in the United States and from Latin America, such as Columbia and Venezuela, will be the currently most cost-competitive and likely sources for coal fuel. Available sources of petcoke are refineries in the Gulf of Mexico and Caribbean regions. These potential fuel sources may change based on future pricing and availability considerations.

The Polk Unit 6 IGCC Project has been designed to be capable of utilizing these primary solid fuels at ratios ranging from 100 percent coal to 100 percent petcoke and various coal/petcoke blends in between. The Project will also be capable of using small quantities (e.g., up to 5 percent) of other fuels, such as biomass, in blends with the primary coal and petcoke fuels. For overall Project design purposes, a blend of 80 percent bituminous coal and 20 percent petcoke is considered to be the normal operating case for the long-term operations of Polk Unit 6. Another fuel used for the Polk Unit 6 Project will be ULSD. ULSD will be fired in the new emergency generator and emergency firewater pumps.

## 2.2.1 FUEL QUALITY AND QUANTITY

### Solid Fuels

Another advantage of IGCC technology in combination with the use of advanced, highly efficient Selexol™ sulfur removal system for Polk Unit 6 is that higher sulfur coals and petcoke can be utilized while still minimizing SO<sub>2</sub> air emissions. Table 2-2 provides the design properties of the bituminous coal and petcoke fuels based on Tampa Electric's evaluations of the typical coals from the various mines in the regions most likely to be considered as sources for coal supply and of petcoke refinery sources in the Gulf Coast and Caribbean regions. Table 2-2 also provides the fuel specifications for the normal operating case fuel of an 80-percent coal and 20-percent petcoke blend. Table 2-3 presents the estimated maximum quantities of coal and petcoke fuels for feedstock to the gasifiers under the range of operating scenarios of 100 percent coal to 100 percent petcoke and the normal operating case of 80 percent coal and 20 percent petcoke.

In addition, Polk Unit 6 will be capable of using biomass in small quantities (i.e., less than 5 percent) blended with the primarily coal and petcoke fuels as feedstock in the gasification process. The selection and use of biomass fuels will be based on the availability of local sources which can be economically obtained and transported to the PPS Site. Examples of such potential biomass fuels may include grass clippings, eucalyptus leaves, or other soft vegetation. Specific information on the quality and quantities of potential biomass fuels will be available when such potential fuels are identified in the future. Further, since potential biomass fuels will be used in small quantities and have significantly lower heating values than the primary solid fuels, any potential use of such fuels will not significantly reduce the quantities of the primary coal and petcoke fuels used for Polk Unit 6.

Table 2-2. Design Properties for Coal, Petcoke, and Normal Operating Case Blend

Parameter	Units	Coal	Petcoke	NOC Blend
Carbon	Weight percent dry	69.49	89.18	76.24
Hydrogen	Weight percent dry	4.76	3.57	4.69
Nitrogen	Weight percent dry	1.41	1.5	1.48
Oxygen	Weight percent dry	7.05	0.00	5.85
Chlorine	Weight percent dry	0.10	0.01	0.10
Sulfur	Weight percent dry	4.69	5.70	3.70
Ash	Weight percent dry	12.50	0.05	7.94
Moisture	Weight percent as received	14.00*	5.50†	11.20
Heating value, HHV	Btu/lb, dry	12,513	15,191	13,523
SO <sub>2</sub>	lb/MMBtu	7.50	7.50	5.50

\*Maximum.

†Minimum.

Note: Btu/lb = British thermal unit per pound.

HHV = higher heating value.

NOC = Normal operating case blend of 80-percent coal and 20-percent petcoke.

Source: Tampa Electric, 2007.

Table 2-3. Design Quantities of Solid Fuel Feedstock at Full Load

	Unit	Coal (100 percent)	Petcoke (100 percent)	NOC Blend
Maximum rate of fuel use	ton/hr, dry	255	202	221

Source: GE, 2007.

### **Natural Gas**

As discussed previously, to provide for fuel flexibility, Polk Unit 6 will be capable of firing natural gas in the CTs as backup fuel. Natural gas could also be fired in the CTs in combination with syngas. In addition, natural gas will be used during startups for preheating the gasifiers and other plant equipment, for firing the auxiliary boiler, and as fuel for the flare pilot flame systems. The existing natural gas supply line to PPS from the Florida Gas Transmission (FGT) pipeline system has adequate capacity to provide the additional natural gas requirements for Polk Unit 6. Table 2-4 presents the typical composition of the FGT pipeline system natural gas in Florida.

The quantity of natural gas utilized for Polk Unit 6 will depend on the number and duration of startups requiring equipment preheating and/or steam from the 300 million British thermal units per hour (MMBtu/hr) auxiliary boiler, and the extent of the need for operating the CTs on natural gas backup fuel.

### **ULSD Fuel**

ULSD will be used for the new emergency generator and emergency firewater pumps. Table 2-5 presents the typical composition of ULSD fuel. The ULSD will have a maximum sulfur content of 0.0015 weight percent.

The quantity of ULSD used for the Polk Unit 6 operations will depend on the need for the use of the emergency equipment. Routine testing of the emergency generator and emergency firewater pump engines will be conducted once a month for a maximum of 100 hours per year (hr/yr) per engine.

## **2.3 PROJECT DESCRIPTION AND FLOW DIAGRAM**

The IGCC electric generating technology involves the integration of coal gasification technology with conventional combined-cycle power plant facilities. Simplistically, in the IGCC technology, coal or other solid fuels are converted to a clean, burnable gas

Table 2-4. Typical Natural Gas Composition

Component	Mole Percent (by volume)
<u>Gas Composition</u>	
Pentane	<0.1
Propane	0.3
I-butane	0.1
N-butane	0.1
Nitrogen	0.3
Methane	96.8
Carbon dioxide	0.8
Ethane	1.6
<u>Other Characteristics</u>	
Heat content (HHV)	1,020 Btu/ft <sup>3</sup>
Sulfur content	2.0 gr/100 dscf*

\*FDEP recommended value; monthly average for 2006 was 0.14 gr/100 dscf for FGT Perry Stream No. 1.

Note: Btu/ft<sup>3</sup> = British thermal units per cubic foot.  
gr/100 dscf = grains per 100 dry standard cubic foot.

Sources: Tampa Electric, 2007.  
ECT, 2007.

Table 2-5. Typical ULSD Composition

Component	Maximum
Carbon residue on 10-percent bottoms	0.25 weight percent
Water and sediment	0.50 percent volume
Vanadium	1.5 ppm
Calcium	4.0 ppm
Sulfur	0.0015 weight percent
Ash	100 ppm
Lead	1.0 ppm
Heat content (HHV) (minimum)	130,000 Btu/gal

Note: ppm = part per million.  
 Btu/gal = British thermal unit per gallon.

Source: ECT, 2007.

which is used to fuel a CT to generate electricity. The hot exhaust from the CT is used to produce steam in a HRSG which is then used in a steam turbine generator to produce additional electricity.

During the 1990s, as part of the efforts to demonstrate commercial viability and environmentally acceptable use of the United States' most abundant energy resource, the Department of Energy (DOE) cofunded two IGCC projects: (1) Wabash River Repowering project in Indiana using the Conoco Phillips E-Gas (formerly Dow/Destec) gasification process and (2) Tampa Electric's Polk Unit 1 IGCC plant in Polk County using the General Electric (GE) (formerly Texaco) gasification process. Tampa Electric has successfully operated the Polk Unit 1 IGCC plant for over 10 years and the plant is one of the best-known and highly acclaimed IGCC units in the world. Tampa Electric's experience and expertise with Unit 1 will provide significant advantages in the design, construction, and operation of the proposed state-of-the-art Polk Unit 6 IGCC Project.

The Polk Unit 6 IGCC Project can be divided into two major process groups: feedstock gasification and combined-cycle power generation. The feedstock gasification process converts feedstock (coal, petcoke, and biomass) into syngas and also includes processes that remove particulates, mercury, nitrogenous compounds, and sulfur. The clean *sweet* syngas resulting from the gasification process is used as fuel for the Unit 6 CTs. The CTs are a part of the combined-cycle power process, which provides electricity to the electrical grid. Figure 2-4 provides an overall block flow schematic diagram of the proposed Project outlining the gasification and combined-cycle islands.

Major components of Polk Unit 6 include the following:

- Solid fuel receiving, storage, handling, and preparation equipment.
- Two oxygen blown entrained-flow gasifiers.
- Syngas treatment equipment including particulate, sulfur, mercury, and nitrogen compound removal.
- A flare for syngas combustion during startups, shutdowns, and plant upsets.



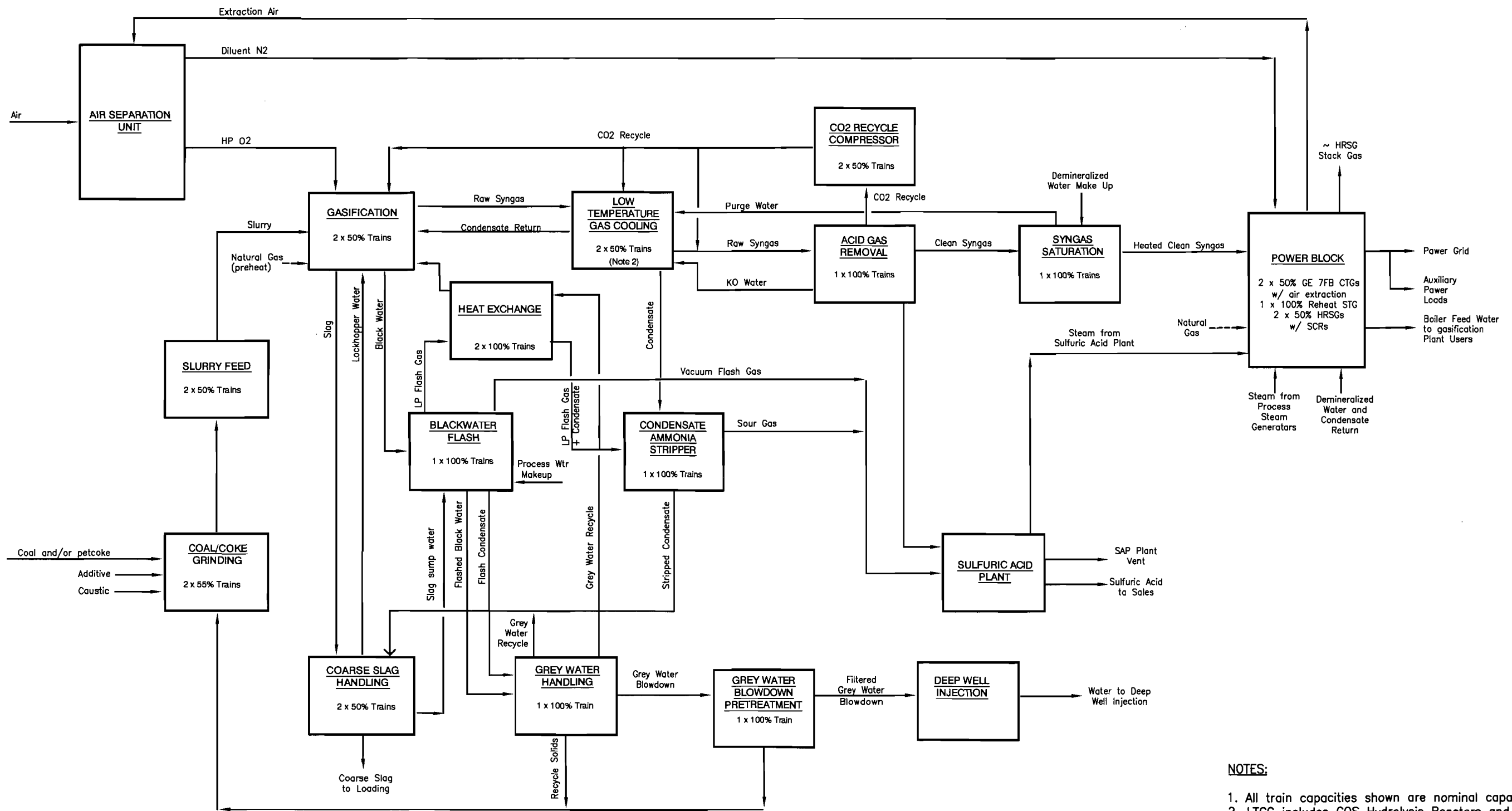

**NOTES:**

1. All train capacities shown are nominal capacities.
2. LTGC includes COS Hydrolysis Reactors and Mercury Guard Beds.

**FIGURE 2-4.**  
**PRELIMINARY BLOCK FLOW DIAGRAM FOR POLK UNIT 6 PROJECT**

Sources: GE Energy (USA) LLC, 2007.



- Two CT/HRSG units comprised of GE 7FB CTs fired with either syngas or natural gas, and one steam turbine generator.
- A mechanical draft cooling tower.
- Sulfuric acid plant associated with the syngas sulfur removal system.
- Auxiliary boiler.
- Emergency diesel generator and firewater pump engines.

### **2.3.1 SOLID FUEL RECEIVING, STORAGE, PREPARATION, AND HANDLING**

The primary solid fuels, bituminous coal and petcoke, for Polk Unit 6 will be delivered to the PPS Site by unit trains, trucks, or a combination of trains and trucks. Currently, all coal for existing Polk Unit 1 is delivered by trucks, unloaded in elevated unloading facilities, and stored in silos. The coal is trucked from Tampa Electric's Big Bend Station located along Tampa Bay in southwest Hillsborough County, approximately 35 miles west of the PPS Site. The coal is initially transported to the Big Bend Station by barge.

For the proposed Polk Unit 6 Project, new railroad delivery facilities will be constructed that will also be integrated for use for the existing Polk Unit 1. As shown in Figure 2-1, these new facilities will consist of an approximately 2,000-ft rail spur from the CSX rail system along CR 663 on the east side of the PPS Site. This new rail spur will interconnect the existing rail line on the Site, which was previously used for large equipment deliveries during the construction of Unit 1. Also, as shown in Figure 2-1, a new approximately 6,300-ft rail loop and railcar unloading facilities will be constructed to the west of the existing PPS facilities. These new rail spur, loop, and unloading facilities will provide for the delivery of coal and petcoke by unit trains for the proposed Polk Unit 6. A new conveyor system will be constructed, and the existing truck delivery system will be modified so that solid fuels from the rail delivery facilities can also be fed to the existing Polk Unit 1 fuel handling facilities. In addition, the truck delivery system modifications will include new conveyor facilities to feed fuel from the truck delivery station to the active fuel storage piles for use by the proposed Polk Unit 6. Therefore, with these new and

modified facilities, solid fuels can be delivered by either unit train and/or truck for use by either the proposed Polk Unit 6 or existing Unit 1.

Coal and petcoke fuels will be delivered to the PPS Site by unit trains in bottom dump rail cars. The unit trains will typically consist of approximately 100 cars for delivery of coal from distant sources and approximately 50 to 100 cars for delivery of petcoke from nearer Gulf Coast refinery and rail terminal locations. Each railcar will contain approximately 100 to 110 tons of fuel. The bottom dump unloading system will be capable of unloading a 100-car train in approximately 4 hours. Trucks used for solid fuel delivery will typically be self-dumping or bottom-dumping, with a capacity of approximately 35 tons.

Currently, for the existing Polk Unit 1, all solid fuels are delivered to the PPS Site by trucks at a frequency of approximately 90 trucks per day, 7 days per week. With the addition of the proposed Polk Unit 6, the frequency of fuel deliveries will depend on such factors as the split of deliveries between the two transportation methods, the percentage of coal versus petcoke fired in the units, the fuel sources and associated available transportation methods, and the cost-competitiveness of the delivery methods. The estimated maximum (i.e., 100-percent load) fuel consumption rate for both Units 1 and 6 will be approximately 8,250 tons per day (tpd). As an example of delivery frequencies, if all coal and petcoke fuel were delivered by rail, approximately one unit train per day would be required to meet the maximum fuel consumption rates for both Units 1 and 6. As another example, if both units were firing 80-percent coal and 20-percent petcoke, and all coal was delivered by unit trains, and all petcoke by trucks, approximately four to five unit trains per week and approximately 45 to 50 trucks per day would be required.

Coal and petcoke fuels unloaded at the train unloading station will be conveyed to a transfer tower and then to either the active fuel storage pile or inactive storage piles located within the new rail loop (see Figure 2-2). An emergency stackout pile area will also be provided so that the trains can be unloaded even if the primary stackout conveyor is unavailable. The emergency stackout pile will have the capacity to store up to

10,000 tons of fuel, which is equivalent to one unit train delivery. The active fuel storage pile area will be designed to contain up to approximately 41,500 tons of solid fuel, which is equivalent to approximately 5 days of operation of Polk Units 1 and 6 at the units' estimated maximum fuel consumption rates. The active storage pile area will be approximately 350 by 175 ft with piles up to 65 ft high. The active storage area will be split into two or more separate fuel piles with precast concrete separation walls between each fuel type, coal, petcoke, and/or different coals. Reclaim from the active piles will utilize two 100-percent redundant portal reclaimers. Reclaimed fuel will be conveyed to one of three fuel storage silos in the fuel blending area. Blended fuels will then be transported via belt conveyors to blending hoppers in the fuel grinding area.

As shown in Figure 2-2, two inactive fuel storage pile areas will be located within the rail loop. The two inactive storage piles will cover an area of approximately 18.4 acres and will be designed to contain a storage capacity of approximately 289,000 tons of coal and petcoke fuels, which is equivalent to 35 days of fuel supply for both Units 1 and 6 at maximum consumption rates. Mobile equipment (i.e., bulldozers) will be used to grade and pack the inactive piles to minimize potential fugitive dust. Fuel from the inactive piles will be reclaimed by mobile equipment to a bulldozer trap. The reclaimed fuel will then be transported to the fuel blending area via belt conveyors.

As required, both the active and inactive fuel storage piles will have water or surfactant spray systems to minimize potential fugitive dust emissions during stackout and reclaim operations and while the fuels are stored in the piles. Also, fugitive dust (i.e., PM) suppression and/or collection systems will be utilized at the fuel unloading, conveyor transfer points, and fuel blending facilities to control fugitive emissions.

The active, inactive, and emergency stackout fuel storage piles will have a low-permeability lining to prevent potential leachate from infiltrating into the ground water and leachate and stormwater runoff collection systems. The stormwater runoff and leachate from these storage areas will be directed to a lined runoff pond located to the

south of the rail loop and treated, as necessary, prior to being discharged to the cooling water reservoir.

The specific source and types of biomass fuels that may be utilized by the proposed Polk Unit 6 are undetermined at this time. It is anticipated that potential biomass fuel will be delivered to the PPS Site by trucks. As shown in Figure 2-2, an area for the delivery, handling, and storage of potential biomass fuel has been included in the Site layout, located to the south of the fuel blending area.

### **2.3.2 GASIFICATION PROCESS**

Tampa Electric will use GE gasification and power generation technologies for the proposed Polk Unit 6 Project. These technologies were also used for the existing Polk Unit 1 IGCC plant; however, significant improvements in these technologies have occurred over the past 15 years which will be incorporated into the design of Polk Unit 6 to enhance the plant operational and environmental performance.

In general, coal, petcoke, and potentially biomass fuels will be delivered to the PPS Site by unit trains and/or by trucks. The solid fuels will be unloaded and stored in lined active or inactive storage piles. Fuels from the active storage piles will be reclaimed and blended in the desired ratios ranging from 100 percent coal to 100 percent petcoke. The fuels will then be ground in rod mills and mixed with water to make a slurry which will be stored in tanks prior to being injected into the gasifier.

The Polk Unit 6 Project will have two gasification trains, each consisting of a refractory-lined gasifier vessel and radiant syngas cooler. In the gasification process, the fuel slurry and oxygen will be injected by high-pressure pumps and react at high pressure and temperatures to produce syngas. Oxygen for the gasification process will be provided by a new air separation unit which separates air into its two major components, oxygen and nitrogen. The syngas will be cooled in the radiant coolers by contact with water to produce steam and remove most of the PM (i.e., slag) from the syngas. This slag will consist of ungasified components of the coal and petcoke fuels which will be recovered through

lockhopper systems in the bottom of the gasifier and radiant cooler facilities. Slag is a vitrified nonhazardous solid byproduct which will be marketed and sold for offsite commercial use based on Tampa Electric's experience with Polk Unit 1 operations. Non-commercial grade slag will be temporarily stored onsite in the existing lined slag storage area prior to reuse within the gasification process. No changes in the existing slag storage area will be needed for the proposed Polk Unit 6 Project.

The raw syngas from the gasifiers will be fed to several stages of cooling and heat recovery followed by advanced syngas cleanup systems. The syngas cleanup systems will consist of water scrubbers to remove remaining particulate matter and will also include COS hydrolysis removal systems. Next, the syngas will be treated in the advanced UOP Selexol™ acid gas removal system to remove sulfur in the syngas. The resulting sulfur compounds will be routed to a new sulfuric acid plant to produce commercial grade sulfuric acid byproduct which will be sold for offsite uses, similar to the Unit 1 operations. The syngas will be further treated in an activated carbon system to achieve an overall removal efficiency of mercury in the solid fuel feedstock of at least 90 percent. Also, in recognition that some form of CO<sub>2</sub> regulation may be enacted during the operational lifetime of the plant, the Polk Unit 6 Project will be carbon-capture ready, that is, capable of adding equipment to capture CO<sub>2</sub> if required in the future.

### **2.3.3 COMBINED-CYCLE PROCESS**

#### **2.3.3.1 Power Block**

The CT generators for the proposed Polk Unit 6 Project will be two 230-MW GE 7FB units, each with a HRSG. The clean syngas will be saturated with water vapor prior to firing in the CT generators, and nitrogen from the air separation unit will be injected as a diluent to limit the formation of NO<sub>x</sub> in the combustion process and augment the efficiency of the unit's electricity production. In addition, SCR systems will be used in the HRSGs to further reduce NO<sub>x</sub> emissions.

### **2.3.3.2 Cooling System**

The addition of the proposed Unit 6 Project will require additional water supply at the PPS Site for cooling and plant process water uses. The proposed Project will be integrated into the existing PPS operations and designed to minimize the use of water and maximize the recycling/reuse of water. For the Polk Unit 6 Project, the existing 755-acre cooling reservoir will be used for condenser cooling purposes, similar to the existing Unit 1 operations. A new mechanical draft cooling tower will be constructed to provide for cooling for other auxiliary heat exchanger systems and the air separation unit for the proposed Unit 6; similar noncondenser cooling systems for the existing Unit 1 will also be modified to also use the new cooling tower. Makeup water to replace losses due to evaporation for the cooling tower will be supplied from the existing cooling reservoir.

The cooling system consisting of the existing cooling water reservoir and a new mechanical draft cooling tower will be used for heat dissipation/condenser cooling for the existing units and proposed Polk Unit 6. Cooling water from the reservoir will be used for condensing and cooling the steam turbine exhaust. For Unit 6, the air separation unit and other plant auxiliary equipment will use a new cooling tower to dissipate the heat. In addition, the auxiliary cooling system for Unit 1 will be modified to remove the air separation unit and other auxiliary cooling loads from the cooling reservoir and place them on the cooling tower. This will reduce heat load to the cooling reservoir and keep the reservoir temperature within an acceptable range.

## **2.4 EMISSIONS AND STACK PARAMETERS**

Emission sources at Polk Unit 6 include the following:

- CT/HRSG trains 1 and 2.
- Sulfuric acid plant.
- Auxiliary boiler.
- Gasifier preheat trains 1 and 2.
- Flare.
- Emergency firewater pump diesel engines.
- Emergency generator diesel engine.

- Mechanical draft cooling tower.
- Feedstock and slag storage piles.
- Feedstock handling.

The locations of these emission sources is shown on Figure 2-5.

The primary source of emissions from the Polk Unit 6 Project will result from the combustion of fuels in the CT/HRSG units. The criteria pollutant emissions for each individual CT/HRSG unit for both syngas and natural gas firing are shown in Table 2-6. Other constituents of interest (i.e., H<sub>2</sub>SO<sub>4</sub> mist, mercury, ammonia, and CO<sub>2</sub>) are shown in Table 2-7. The CT/HRSGs are the only significant source of hazardous air pollutant (HAP) emissions from the sources associated with the Polk Unit 6 Project, with each unit emitting 1.5 tpy of HAPs when firing syngas. More details regarding CT/HRSG emission rates may be found in Appendix A of this document.

The sulfuric acid plant will be based on the dual absorption contact or wet H<sub>2</sub>SO<sub>4</sub> process. The plant will be capable of producing 880 tpd, or 321,200 tpy, of 100 percent H<sub>2</sub>SO<sub>4</sub>. Potential emissions of SO<sub>2</sub> will be 36.7 lb/hr and 160.6 tpy. Potential emissions of H<sub>2</sub>SO<sub>4</sub> mist will be 3.7 lb/hr and 16.1 tpy. Mist eliminators will be used to provide additional control of H<sub>2</sub>SO<sub>4</sub> mist. Additional minor emissions of criteria pollutants and H<sub>2</sub>SO<sub>4</sub> mist will result from startup/shutdown operations. Three startup/shutdown events per year have been assumed for estimating emissions. The highest pollutant emissions are for SO<sub>2</sub> at 1.3 tpy from startup and shutdown of the unit. All other pollutants attributable to startup/shutdown activities are less than 1 tpy.

The auxiliary boiler is used to provide steam to the process for startup of the gasifiers and CT/HRSGs. The auxiliary boiler will be fired exclusively with natural gas, and will operate no more than 10 percent of the time (i.e., 876 hr/yr). The boiler will have a heat input rate of 300 MMBtu/hr (HHV). The criteria pollutant emissions for the auxiliary boiler are shown in Table 2-8.



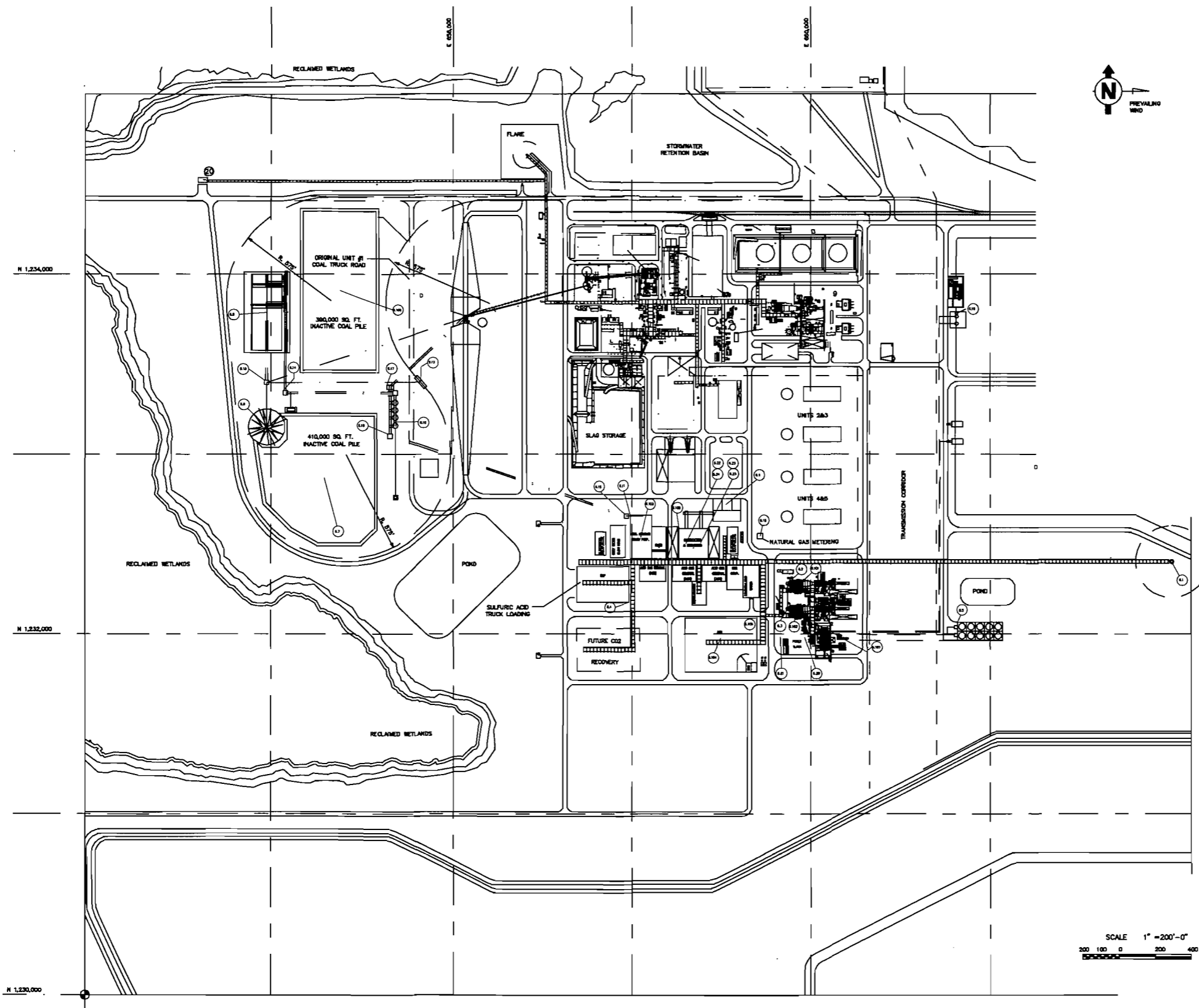

UNIT	ITEM	DESCRIPTION
6	1	FLARE (50-MB-001)
6	2	HSRG TR 1 STACK
6	3	HSRG TR 2 STACK
6	4	SULPHURIC ACID PLANT VENT
6	5	COOLING TOWER (52-ME-001)

Material Handling Emissions Points		
6	6	ACTIVE FUEL PILE
6	7	INACTIVE FUEL PILE (south)
6	8	EMERGENCY FUEL STACK OUT PILE
6	9	SLAG STACK OUT AREA
6	10	FUEL BLENDING DUST COLLECTOR VENT
6	11	COAL GRID - SLURRY BLDG BAGHOUSE VENT
6	12	FUEL UNLOADING-POINT (DUST SUPPRESSION)
6	13	FUEL UNLOADING-TRANSFER TOWER (DUST SUPPRESSION)
6	14	RECLAIM TRANSFER TOWER (DUST SUPPRESSION)
6	15	UNIT 6 TRANSFER TOWER (DUST SUPPRESSION)
6	16	FUEL TRANSFER POINT (SPARE EMISSIONS POINT)
6	17	FUEL TRANSFER POINT (SPARE EMISSIONS POINT)

Small Emissions Points (Normal Operation)		
6	18	GAS METERING STATION
6	19	DIESEL FIREWATER PUMP STACK(53-MP-003A)
6	20	EMERGENCY DIESEL GENERATOR EXHAUST(54-MG-001)
6	21	AUX BOILER STACK(43-MB-001)

Startup Emissions Points		
6	22	GASIFIER # 1 O2 VENT
6	23	GASIFIER # 2 O2 VENT
6	24	STARTUP ASPIRATOR SILENCER("Atm Vent1")
6	25	STARTUP ASPIRATOR SILENCER("Atm Vent 2")

Structures		
6	101	HSRG TRAIN 1 TO DRUM C-LINE
6	102	HSRG TRAIN 2 TO DRUM C-LINE
6	103	NOT USED
6	104	NOT USED
6	105	NOT USED
6	106	AUX BOILER STRUCTURE
6	107	STEAM TURBINE GENERATOR STRUCTURE
6	108	GASIFICATION STRUCTURE
6	109	INACTIVE FUEL PILE (north)

FIGURE 2-5.  
UNIT 6 - LOCATION OF AIR EMISSION SOURCES

Source: Bechtel, 2007; ECT, 2007.



Table 2-6 . CT/HRSG - Criteria Pollutant Emission Rates (per CT/HRSG Unit)

Pollutant	Units	Value* (syngas firing)	Value* (natural gas firing)
Operating hours	hr/yr	8,760	8,760
Output	MW, gross	413.3	267.0
Gasifier heat input	MMBtu/hr (HHV)	3,200	N/A
CT heat input	MMBtu/hr (HHV)	2,571	1,980
NO <sub>x</sub>	lb/MMBtu	0.032	0.019
	lb/MWh, gross	0.24	0.045
	ppmvd @ 15% oxygen	9.1	5.1
	tpy	433.6	144.5
	lb/hr	100.0	36
SO <sub>2</sub>	lb/MMBtu	0.017	0.0056
	lb/MWh, gross	0.14	0.045
	ppmvd @ 15% oxygen	4.0	1.1
	tpy	227.8	44.3
	lb/hr	54.0	11.1
CO	lb/MMBtu	0.032	0.047
	lb/MWh, gross	0.26	0.38
	ppmvd @ 15% oxygen	17.4	21.2
	tpy	407.3	354.8
	lb/hr	94.0	90
VOC	lb/MMBtu	0.0012	0.0017
	lb/MWh, gross	0.0098	0.014
	ppmvd @ 15% oxygen	1.1	1.4
	tpy	14.5	13.1
	lb/hr	3.3	3.3
PM/PM <sub>10</sub> (total)	lb/MMBtu	0.019	0.015
	lb/MWh, gross	0.16	0.12
	tpy	170.8	78.8
	lb/hr	39.0	18
Lead	lb/MMBtu	4.00	0.49
	lb/MWh, gross	0.000033	3.91 x 10 <sup>-6</sup>
	tpy	0.054	0.0039
	lb/hr	0.0128	0.0010

Note: Emission rates in lb/10<sup>6</sup> Btu based on heat input to the gasifier.

\*Maximum rates for all operating cases.

Source: ECT, 2007.

Table 2- 7. CT/HRSG - H<sub>2</sub>SO<sub>4</sub> Mist, Mercury, Ammonia, and CO<sub>2</sub> Emission Rates  
(per CT/HRSG Unit)

Pollutant	Units	Value (syngas firing)	Value (natural gas firing)
Operating hours	hr/yr	8,760	8,760
Output	MW, gross	413.3	267.0
Gasifier heat input	MMBtu (HHV)	3,200	N/A
CT heat input	MMBtu (HHV)	2,571	1,980
H <sub>2</sub> SO <sub>4</sub> Mist	lb/MMBtu	0.0040	0.00086
	lb/MWh, gross	0.033	0.0069
	tpy	53.4	6.8
	lb/hr	12.8	1.7
Mercury	lb/10 <sup>12</sup> Btu	1.0	0.25
	lb/MMBtu/MWh, gross	8.2	2.0
	tpy	0.013	0.0020
	lb/yr	26.9	0.00050
	lb/hr	0.0031	0.000063
Ammonia	lb/MMBtu	0.0066	0.0068
	lb/MWh, gross	0.050	0.054
	ppmvd @ 15% oxygen	5.0	5.0
	tpy	89.0	53.6
	lb/hr	20.4	13.4
Carbon Dioxide	lb/MMBtu	203.4	117.6
	lb/MWh, gross	1,673	940
	tpy	2,628,282	929,629
	lb/hr	624,819	232,956

Note: Emission rates in lb/10<sup>6</sup> Btu based on heat input to the gasifier.

Source: ECT, 2007.

Table 2- 8. Auxiliary Boiler - Criteria Pollutant Emission Rates

Pollutant	Units	Value
Operating hours	hr/yr	876
Heat input (100-percent load)	MMBtu (HHV)	300
NO <sub>x</sub>	lb/MMBtu	0.036
	tpy	4.7
	lb/hr	10.8
SO <sub>2</sub>	lb/MMBtu	0.0059
	tpy	0.77
	lb/hr	1.8
CO	lb/MMBtu	0.036
	tpy	4.7
	lb/hr	10.8
VOC	lb/MMBtu	0.011
	tpy	1.4
	lb/hr	3.2
PM/PM <sub>10</sub>	lb/MMBtu	0.007
	tpy	1.0
	lb/hr	2.2
Lead	lb/MMBtu	4.90E-07
	tpy	6.40E-05
	lb/hr	1.47E-04

Source: ECT, 2007.

Emissions from the flare are associated with gasifier startup/shutdown events, which have been estimated at 26 during the first year. Estimated flare emissions are 51.2 tpy of SO<sub>2</sub>, 16.0 tpy of CO, and 3.8 tpy of NO<sub>x</sub>. Emissions of PM<sub>10</sub> and VOC are each estimated to be less than 0.1 tpy.

There will be two diesel engines associated with the firewater pumps and one diesel engine for the emergency generator. Criteria emissions and other parameters for the firewater pump diesel engines, and the emergency generator diesel engine, are shown in Tables 2-9 and 2-10, respectively. As stated earlier, the diesel engines will be fired with ULSD fuel resulting in very low SO<sub>2</sub> emissions. The emissions from these engines are relatively small, and have been based on the periodic maintenance and testing required (i.e., 100 hr/yr of non-emergency operation). HAP emissions from these units are negligible, and can be found in Appendix A of this document.

The only criteria pollutant emitted from the cooling tower is PM<sub>10</sub>. The cooling tower will be equipped with highly efficient drift eliminators (i.e., limiting the drift loss rate to 0.0005 percent), which will result in approximately 0.6 tpy of PM<sub>10</sub> emissions.

Feedstock and slag storage and handling operations will result in the emissions of PM. Emissions will be controlled primarily by the use of water/surfactant sprays, enclosures, and baghouses. The total PM<sub>10</sub> emissions from these operations have been estimated to be approximately 3.94 tpy. Additional details may be found in Appendix A of this document.

Table 2-11 provides a summary of the annual emissions for the Polk Unit 6 Project. Note that the total emissions from the CT/HRSGs include emissions for startup and shutdown. Also, the total emissions from the sulfuric acid plant include emissions from startup and shutdown of that unit. The stack parameters for the emission units are shown in Table 2-12.

Table 2-9. Firewater Pump Diesel Engines - Criteria Pollutant Emission Rates

Pollutant	Units	Value (per engine)
Operating hours	hr/yr	100*
Heat input (100-percent load)	kW	313
	hp	420
NO <sub>x</sub>	g/kW-hr	10.5
	tpy	0.36
	lb/hr	7.2
SO <sub>2</sub>	g/kW-hr	0.0074
	tpy	0.00025
	lb/hr	0.0051
CO	g/kW-hr	3.5
	tpy	0.12
	lb/hr	2.4
VOC	g/kW-hr	1.5
	tpy	0.05
	lb/hr	1.1
PM/PM <sub>10</sub>	g/kW-hr	0.54
	tpy	0.0186
	lb/hr	0.37
Lead	g/kW-hr	negligible
	tpy	negligible
	lb/hr	negligible

Note: g/kW-hr = grams per kilowatt hour.

\*Excluding operation during emergency conditions.

Source: ECT, 2007.

Table 2-10. Emergency Generator Diesel Engine - Criteria Pollutant Emission Rates

Pollutant	Units	Value
Operating hours	hr/yr	100*
Heat input (100-percent load)	kW	1,641
	hp	2,200
NO <sub>x</sub>	g/kW-hr	6.4
	tpy	1.2
	lb/hr	23.1
SO <sub>2</sub>	g/kW-hr	0.0074
	tpy	0.0013
	lb/hr	0.0267
CO	g/kW-hr	3.5
	tpy	0.63
	lb/hr	12.7
VOC	g/kW-hr	0.4
	tpy	0.078
	lb/hr	1.6
PM/PM <sub>10</sub>	g/kW-hr	0.2
	tpy	0.0360
	lb/hr	0.72
Lead	g/kW-hr	negligible
	tpy	negligible
	lb/hr	negligible

Note: hp = horsepower.

\*Excluding operation during emergency conditions.

Source: ECT, 2007.

Table 2-11. Polk Unit 6 Annual Emission Rate Summary  
(emissions are in tpy except for mercury which is reported as lb/yr)

Pollutant	CT/HRSG Trains 1 & 2	Sulfuric Acid Plant	Auxiliary Boiler	Gasifier Preheat	Flare	Firewater Pump Engines	Emergency Generator Engine	Cooling Tower	Feedstock/ Slage Storage & Handling	Total Emissions
<u>Criteria Pollutants</u>										
NO <sub>x</sub>	911.9	0.78	4.7	0.90	3.8	0.72	1.16	Neg	Neg	924.0
CO	885.8	0.66	4.7	0.76	16.0	0.24	0.63	Neg	Neg	908.8
VOC	36.3	0.04	1.4	0.05	0.05	0.11	0.08	Neg	Neg	38.0
SO <sub>2</sub>	456.1	161.9	0.77	0.05	51.2	0.0005	0.0013	Neg	Neg	670.0
PM <sub>10</sub> (total)	345.8	16.2	1.0	0.07	0.07	0.037	0.036	0.60	3.94	367.7
Lead	0.11	Neg	Neg	Neg	Neg	Neg	Neg	Neg	Neg	0.11
<u>Hazardous Air Pollutants</u>										
Formaldehyde	4.7	Neg	Neg	Neg	Neg	Neg	Neg	Neg	Neg	4.7
Total HAPs	9.8	Neg	Neg	Neg	Neg	Neg	Neg	Neg	Neg	9.8
<u>Other Pollutants</u>										
H <sub>2</sub> SO <sub>4</sub> Mist	106.9	16.2	Neg	Neg	Neg	Neg	Neg	Neg	Neg	123.1
PM (filterable)	161.8	16.1	1.0	Neg	0.07	0.037	0.036	25.8	5.9	210.7
Ammonia	178.0	Neg	Neg	Neg	Neg	Neg	Neg	Neg	Neg	178.0
CO <sub>2</sub>	5,256,564	219,024	15,459	Neg	Neg	48	128	Neg	Neg	5,491,223
Mercury (lb/yr)	53.8	Neg	Neg	Neg	Neg	Neg	Neg	Neg	Neg	53.8

Note: acfm = actual cubic foot per minute.

ft<sup>2</sup> = square feet.

ft/sec = feet per second.

m/sec = meter per second.

The CT/HRSG includes startup/shutdown.

The sulfuric acid plant includes startup and shutdown emissions.

Source: ECT, 2007.



Table 2-12. Stack Parameters

Parameter	Units	Emission Source						
		CT/HRSGs Stacks†	Sulfuric Acid Plant Vent	Flare	Auxiliary Boiler	Generator Diesel Engine	Firewater Pump Diesel Engine	Cooling Tower*
Height above grade	ft	175	275	200	100	18	12	42
	meter	53.3	83.8	61.0	30.5	5.5	3.7	12.8
Exit diameter	ft	18.6	6.5	4.0	5.0	0.8	0.7	37.5
	meter	5.67	1.98	1.22	1.52	0.24	0.21	11.43
Stack area	ft <sup>2</sup>	271.7	33.2	12.6	19.6	0.5	0.4	1,104.5
Flow rate	acfm	1,310,482	57,739	N/A	70,686	10,600	2,080	1,789,235
Exit velocity	ft/sec	80.4	29.0	N/A	60.0	351.5	90.0	27.0
	m/sec	24.5	8.8	N/A	18.3	107.1	27.5	8.2
Exit temperature	°F	275.0	180.0	N/A	500.0	800.0	790.0	95.0
	°K	408.2	355.4	N/A	533.2	699.8	694.3	308.2

\* Per cell.

† Syngas, 100 percent load, 0°F ambient.

Source: ECT, 2007.

### 3.0 NEW SOURCE REVIEW REQUIREMENTS

#### 3.1 NATIONAL AND STATE AAQS

As a result of the 1977 CAA Amendments (1990), the EPA has enacted primary and secondary NAAQS for six air pollutants (Chapter 40, Part 50, Code of Federal Regulations [CFR]). Primary NAAQS are intended to protect the public health, and secondary NAAQS are intended to protect the public welfare from any known or anticipated adverse effects associated with the presence of pollutants in the ambient air. Florida has also adopted AAQS (reference Section 62-204.240, F.A.C.). Table 3-1 presents the current national and Florida AAQS.

Areas of the country in violation of AAQS are designated as nonattainment areas, and new sources to be located in or near these areas may be subject to more stringent air permitting requirements. PPS is located in southwest Polk County approximately 13 miles southwest of the city of Bartow. Polk County is presently designated in 40 CFR 81.310 as better than national standards (for total suspended particulates [TSPs], SO<sub>2</sub>, and nitrogen dioxide [NO<sub>2</sub>]), unclassifiable/attainment (for CO, 8-hour ozone, and particulate matter less than or equal to 2.5 micrometers (PM<sub>2.5</sub>), and not designated (for lead). Polk County is designated attainment (for ozone, SO<sub>2</sub>, CO, and NO<sub>2</sub>) and unclassifiable (for PM<sub>10</sub> and lead) by Section 62-204.340, F.A.C.

Although the Florida rules currently include a 1-hour ozone AAQS (reference Rule 62-204.240[4], F.A.C.), on the federal level EPA revoked this standard in Florida effective June 15, 2005. The FDEP plans to adopt both the 8-hour ozone and PM<sub>2.5</sub> NAAQS, and remove the 1-hour ozone AAQS in a single rulemaking project. This future FDEP rulemaking project is anticipated to begin in the fall of 2007 following EPA's planned adoption of a PM<sub>2.5</sub> NSR rule in the summer of 2007.

Table 3-1. National and Florida Air Quality Standards (micrograms per cubic meter [ $\mu\text{g}/\text{m}^3$ ] unless otherwise stated)

Pollutant (units)	Averaging Periods	National Standards		Florida Standards
		Primary	Secondary	
SO <sub>2</sub>	3-hour <sup>1</sup>		1,300	1,300
	24-hour <sup>1</sup>	365		260
	Annual <sup>2</sup>	80		60
PM <sub>10</sub>	24-hour <sup>3</sup>	150	150	150
	Annual <sup>4</sup>			50
PM <sub>2.5</sub>	24-hour <sup>5</sup>	35	35	
	Annual <sup>6</sup>	15	15	
CO	1-hour <sup>1</sup>	40,000		40,000
	8-hour <sup>1</sup>	10,000		10,000
Ozone (ppmv)	1-hour <sup>7</sup>			0.12
	8-hour <sup>8</sup>	0.08	0.08	
NO <sub>2</sub>	Annual <sup>2</sup>	100	100	100
Lead	Calendar Quarter Arithmetic Mean	1.5	1.5	1.5

<sup>1</sup>Not to be exceeded more than once per calendar year.

<sup>2</sup>Arithmetic mean.

<sup>3</sup>The standards are attained when the expected number of days per calendar year with a 24-hour average concentration above 150  $\mu\text{g}/\text{m}^3$ , as determined in accordance with 40 CFR 50 Appendix K, is equal to or less than one.

<sup>4</sup>The standards are attained when the expected annual arithmetic mean concentration, as determined in accordance with 40 CFR 50 Appendix K, is less than or equal to 50  $\mu\text{g}/\text{m}^3$ .

<sup>5</sup>98th percentile concentration, as determined in accordance with 40 CFR 50 Appendix N.

<sup>6</sup>Arithmetic mean concentration, as determined in accordance with 40 CFR 50 Appendix N.

<sup>7</sup>Standard attained when the expected number of calendar days per calendar year with maximum hourly average concentrations above the standard is equal to or less than 1, as determined by 40 CFR 50, Appendix H.

<sup>8</sup>Standard attained when the average of the annual 4<sup>th</sup> highest daily maximum 8-hour average concentrations over a 3-year period are less than or equal to the standard, as determined by 40 CFR 50, Appendix I.

Sources: 40 CFR 50.  
Section 62-204.240, F.A.C.

### **3.2 NONATTAINMENT NSR APPLICABILITY**

PPS is located in Polk County. As noted previously, Polk County is presently designated as either better than national standards or unclassifiable/attainment for all criteria pollutants. Accordingly, Unit 6 is not subject to the nonattainment NSR requirements of Section 62-212.500, F.A.C.

### **3.3 PSD NSR APPLICABILITY**

Unit 6 will have potential emissions greater than one or more of the PSD significant emission rates listed in Rule 62-212.200(278), F.A.C. Accordingly, Unit 6 qualifies as a major modification to an existing major facility and is subject to the PSD NSR requirements of Section 62-212.400, F.A.C., for those pollutants that are emitted at or above the specified PSD significant emission rate levels. Comparisons of estimated potential annual emission rates for Unit 6 and the PSD significant emission rate thresholds are provided in Table 3-2. As shown in this table, potential emissions of NO<sub>x</sub>, CO, PM, PM<sub>10</sub>, SO<sub>2</sub>, and H<sub>2</sub>SO<sub>4</sub> mist are each projected to exceed the applicable PSD significant emission rate level. These pollutants are, therefore, subject to the PSD NSR requirements of Section 62-212.400, F.A.C. Detailed emission rate estimates for Unit 6 are provided in Appendix A.

### **3.4 PSD REQUIREMENTS**

#### **3.4.1 CONTROL TECHNOLOGY REVIEW**

Pursuant to Rule 62-212.400(4)(c), F.A.C., an analysis of BACT is required for each pollutant emitted by Unit 6 in amounts equal to or greater than the PSD significant emission rate levels. As defined by Rule 62-210.200(40), F.A.C., BACT is:

“an emission limitation, including a visible emission standard, based on the maximum degree of reduction of each pollutant emitted which the Department, on a case by case basis, taking into account: (1) energy, environmental, and economic impacts, and other costs, (2) all scientific, engineering, and technical material and other information available to the Department, and (3) the

Table 3-2. Projected Unit 6 Emissions Compared to PSD Significant Emission Rates

Pollutant	Projected Maximum Annual Emissions (tpy)	PSD Significant Emission Rate (tpy)	PSD Applicability
NO <sub>x</sub>	925	40	Yes
CO	910	100	Yes
PM (filterable)	211	25	Yes
PM <sub>10</sub> (filterable and condensable)	368	15	Yes
SO <sub>2</sub>	670	40	Yes
Ozone/VOC	38	40	No
Lead	0.11	0.6	No
Mercury	0.027	0.1	No
Total fluorides	0.61	3	No
H <sub>2</sub> SO <sub>4</sub> mist	123	7	Yes
Total reduced sulfur (including hydrogen sulfide [H <sub>2</sub> S])	Not present	10	No
Reduced sulfur compounds (including H <sub>2</sub> S)	Not present	10	No
Municipal waste combustor acid gases (measured as SO <sub>2</sub> and hydrogen chloride [HCl])	Not present	40	No
Municipal waste combustor metals (measured as PM)	Not present	15	No
Municipal waste combustor organics (measured as total tetra- through octa-chlorinated dibenzo-p-dioxins and dibenzofurans)	Not present	3.5 × 10 <sup>-6</sup>	No
For the pollutants listed above, and for major stationary sources locating within 10 km of a Class I area having an impact equal to or greater than 1 µg/m <sup>3</sup> , 24-hour average	N/A	Any amount	No

Sources: Rule 62-210.200(278), F.A.C.  
 ECT, 2007.  
 TEC, 2007.  
 GE, 2007.  
 Bechtel, 2007.

emission limiting standards or BACT determinations of Florida and any other state, determines if achievable through application of production processes and available methods, systems and techniques (including fuel cleaning or treatment or innovative fuel combustion techniques) for control of each such pollutant.”

BACT determinations are made on a case-by-case basis as part of the FDEP NSR process and apply to each pollutant that exceeds the PSD significant emission rate thresholds shown in Table 3-2. All emission units, which emit or increase emissions of the applicable pollutants, involved in a major modification or a new major source must undergo BACT analysis. Because each applicable pollutant must be analyzed, particular emission units may undergo BACT analysis for more than one pollutant.

BACT is defined in terms of a numerical emissions limit. This numerical emissions limit can be based on the application of air pollution control equipment; specific production processes, methods, systems, or techniques; fuel cleaning; or combustion techniques. BACT limitations may not exceed any applicable federal new source performance standard (NSPS), national emission standard for hazardous air pollutants (NESHAPs), or any other emission limitation established by state regulations.

BACT analyses must be conducted using the following five step *top-down* approach:

1. All available control technology alternatives are identified based on knowledge of the particular industry of the applicant, control technology vendors, technical journals and reports, and previous control technology permitting decisions for other identical or similar sources.
2. The identified available control technologies are evaluated for technical feasibility. If a control technology has been installed and operated successfully on the type of source under review, it is considered demonstrated and technically feasible. An undemonstrated control technology may be considered technically feasible if it is available and applicable. A control technology is considered available if it can be obtained commercially (i.e., the technology has reached the licensing and commercial sales phase of development). An available control technology is applicable if it can reasonably be installed

and operated on the source type under consideration. Undemonstrated available control technologies that are determined to be technically infeasible, based on physical, chemical, and engineering principals, are eliminated from further consideration.

3. The technically feasible technology alternatives are rank-ordered by stringency into a control technology hierarchy.
4. The hierarchy is evaluated starting with the *top*, or most stringent alternative, to determine economic, environmental, and energy impacts and to assess the feasibility or appropriateness of each alternative as BACT based on site-specific factors. If the top control alternative is accepted as BACT from an economic and energy standpoint, evaluation of energy and economic impacts is not required since the only reason for conducting these assessments is to document the rationale for rejecting an alternative technology as BACT. Instead, the applicant proceeds to evaluate the top case control technology for impacts of unregulated air pollutants or impacts in other media (i.e., collateral environmental impacts). If there are no issues regarding collateral environmental impacts, the BACT analysis is complete, and the top case control technology alternative is proposed as BACT. If the top control alternative is not applicable due to adverse energy, environmental, or economic impacts, it is rejected as BACT and the next most stringent control alternative is then considered.
5. This evaluation process continues until an applicable control alternative is determined to be both technologically and economically feasible, thereby defining the emission level corresponding to BACT for the evaluated pollutant.

This five-step procedure for conducting a BACT analysis is described in Chapter B of EPA's *Draft New Source Review Manual* dated October 1990.

The BACT emission limit established during the initial permitting process will be enforceable over the life of the unit. As a result, the BACT analysis must take into account

the full range of possible fuels, operating conditions, operating system fluctuations, and normal wear-and-tear on the units and control systems. EPA's Environmental Appeals Board (EAB) has recognized that "permitting agencies have the discretion to set BACT limits at levels that do not necessarily reflect the highest possible control efficiencies but, rather will allow permittees to achieve compliance on a consistent basis" (Three Mountain Power, PSD Appeal No. 01-05 at 21 [May 30, 2001] citing: In re Masonite Corp., 5 E.A.D. 560-61 [EAB 1994] ["There is nothing inherently wrong with setting an emission limitation that takes into account a reasonable safety factor."]; and In re Knauf Fiber Glass, GmbH, PSD Appeal Nos. 99-8 to -72, slip op. at 21 [EAB, Mar. 14, 2000] ["The inclusion of a reasonable safety factor in the emission limitation is a legitimate method of deriving a specific emission limitation that may not be exceeded."])).

### **3.4.2 AMBIENT AIR QUALITY MONITORING**

In accordance with the PSD requirements of Rule 62-212.400(7), F.A.C., any application for a PSD permit must contain, for each pollutant subject to review, an analysis of ambient air quality data in the area affected by the proposed major stationary source or major modification. The affected pollutants are those which the source would potentially emit in significant amounts (i.e., those that exceed the PSD significant emission rate thresholds shown in Table 3-2).

Preconstruction ambient air monitoring for a period of up to 1 year is generally required. Existing data from the vicinity of the proposed source may be used if the data meet certain quality assurance (QA) requirements; otherwise, additional data may need to be gathered. Guidance in designing a PSD monitoring network is provided by EPA's *Ambient Monitoring Guidelines for Prevention of Significant Deterioration* (1987a).

Rule 62-212.400(3)(e), F.A.C., provides an exemption that excludes or limits the pollutants for which an air quality monitoring analysis is conducted. This exemption states that a proposed facility will be exempt from the monitoring requirements of Rule 62-212.400(7), F.A.C., with respect to a particular pollutant if the emissions increase of the pollution from the new source would cause, in any area, air quality impacts



less than the PSD *de minimis* ambient impact levels presented in Rule 62-212.400(3)(e)1., F.A.C. (see Table 3-3). In addition, an exemption may be granted if the air quality impacts due to existing sources in the area of concern are less than the PSD *de minimis* ambient impact levels.

Applicability of the PSD preconstruction ambient monitoring requirements to Unit 6 is discussed in Section 8.2.

### 3.4.3 AMBIENT IMPACT ANALYSIS

An air quality or source impact analysis must be performed for a proposed major source subject to PSD for each pollutant for which the increase in emissions exceeds the significant emission rates (see Table 3-2). The FDEP rules specifically require the use of applicable EPA atmospheric dispersion models in determining estimates of ambient concentrations (refer to Rule 62-204.220[4], F.A.C.). Guidance for the use and application of dispersion models is presented in the EPA *Guideline on Air Quality Models* (GAQM) as published in Appendix W to 40 CFR 51. Criteria pollutants may be exempt from the full source impact analysis if the net increase in impacts due to the new source or modification is below the appropriate Rule 62-210.200(279), F.A.C., significant impact level (SIL), as presented in Table 3-4. EPA has proposed SILs for Class I areas—these levels are provided in Table 3-5.

Ozone is one pollutant for which a source impact analysis is not normally required. Ozone is formed in the atmosphere as a result of complex photochemical reactions. Models for ozone generally are applied to entire urban areas.

Various lengths of record for meteorological data can be used for impact analyses. A 5-year period can be used with corresponding evaluation of the highest of the second-highest (HSH) short-term concentrations for comparison to AAQS or PSD increments. The term *highest, second-highest* refers to the highest of the second-highest

Table 3-3. PSD *De Minimis* Ambient Impact Levels

Averaging Time	Pollutant	<i>De Minimis</i> Level ( $\mu\text{g}/\text{m}^3$ )
Annual	NO <sub>2</sub>	14
Quarterly	Lead	0.1
24-Hour	PM <sub>10</sub>	10
	SO <sub>2</sub>	13
	Mercury	0.25
	Fluorides	0.25
8-Hour	CO	575
1-Hour	Total reduced sulfur	10
	H <sub>2</sub> S	0.2
	Reduced sulfur compounds	10
NA	Ozone	100 tpy of VOC emissions

Source: Rule 62-212.400(3)(e)1., F.A.C.

Table 3-4. FDEP Significant Impact Levels

Pollutant	Averaging Period	Concentration ( $\mu\text{g}/\text{m}^3$ )
SO <sub>2</sub>	Annual	1
	24-Hour	5
	24-Hour (Class I Areas)	1
	3-Hour	25
PM <sub>10</sub>	Annual	1
	24-Hour	5
	24-Hour (Class I Areas)	1
NO <sub>2</sub>	Annual	1
CO	8-Hour	500
	1-Hour	2,000
Lead	Quarterly	0.03

Source: Rule 62-210.200(279), F.A.C.

Table 3-5. EPA Significant Impact Levels—Class I Areas

Pollutant	Averaging Period	Concentration ( $\mu\text{g}/\text{m}^3$ )
SO <sub>2</sub>	Annual	0.1
	24-Hour	0.2
	3-Hour	1.0
PM <sub>10</sub>	Annual	0.2
	24-Hour	0.3
NO <sub>2</sub>	Annual	0.1

Source: EPA Proposed, 1996; 61FR 38249.

concentrations at all receptors (i.e., the highest concentration at each receptor is discarded). The second-highest concentration is significant because short-term PSD increments specify the standard should not be exceeded at any location more than once per year. If less than 5 years of meteorological data are used, the highest concentration at each receptor must be used.

In promulgating the 1977 CAA Amendments, Congress specified that certain increases above an air quality baseline concentration level for SO<sub>2</sub> and TSP would constitute significant deterioration. The magnitude of the increment that cannot be exceeded depends on the classification of the area in which a new source (or modification) will have an impact. Three classifications were designated based on criteria established in the CAA Amendments. Initially, Congress promulgated areas as Class I (international parks, national wilderness areas, and memorial parks larger than 2,024 hectares [ha] [5,000 acres], and national parks larger than 2,428 ha [6,000 acres]) or Class II (all other areas not designated as Class I). No Class III areas, which would be allowed greater deterioration than Class II areas, were designated. However, the states were given the authority to redesignate any Class II area to Class III status, provided certain requirements were met. EPA then promulgated, as regulations, the requirements for classifications and area designations.

On October 17, 1988, EPA promulgated PSD increments for NO<sub>2</sub>; the effective date of the new regulation was October 17, 1989. However, the baseline date for NO<sub>2</sub> increment consumption was set at February 8, 1988; new major sources or modifications constructed after this date will consume NO<sub>2</sub> increment.

On June 3, 1993, EPA promulgated PSD increments for PM<sub>10</sub>; the effective date of the new regulation was June 3, 1994. The increments for PM<sub>10</sub> replace the original PM increments that were based on TSP. Baseline dates and areas that were previously established for the original TSP increments remain in effect for the new PM<sub>10</sub> increments. Revised NAAQS for PM, which include revised NAAQS for PM<sub>10</sub> and PM<sub>2.5</sub>, became effective on October 17, 2006. Due to the significant technical difficulties that exist with

respect to PM<sub>2.5</sub> monitoring, emissions estimation, and modeling, EPA has determined that implementation of PSD permitting for PM<sub>2.5</sub> is administratively impracticable at this time for state permitting authorities. Accordingly, EPA has advised that PM<sub>10</sub> may be used as a surrogate for PM<sub>2.5</sub> in meeting NSR requirements until these difficulties are resolved.

Current Florida PSD allowable increments are specified in Section 62-204.260, F.A.C., and shown on Table 3-6.

The term *baseline concentration* evolved from federal and state PSD regulations and denotes a concentration level corresponding to a specified baseline date and certain additional baseline sources. By definition in the PSD regulations, as amended, *baseline concentration* means the ambient concentration level that exists in the baseline area at the time of the applicable minor source baseline date. A baseline concentration is determined for each pollutant for which a baseline date is established based on:

- The actual emissions representative of sources in existence on the applicable minor source baseline date.
- The allowable emissions of major stationary sources that commenced construction before the major source baseline date but were not in operation by the applicable minor source baseline date.

The following will not be included in the baseline concentration and will affect the applicable maximum allowable increase(s) (i.e., allowed increment consumption):

- Actual emissions from any major stationary source on which construction commenced after the major source baseline date.
- Actual emissions increases and decreases at any stationary source occurring after the minor source baseline date.

It is not necessary to make a determination of the baseline concentration to determine the amount of PSD increment consumed. Instead, increment consumption calculations need only reflect the ambient pollutant concentration *change* attributable to emission sources

Table 3-6. PSD Allowable Increments ( $\mu\text{g}/\text{m}^3$ )

Pollutant	Averaging Time	Class		
		I	II	III
PM <sub>10</sub>	Annual arithmetic mean	4	17	34
	24-Hour maximum*	8	30	60
SO <sub>2</sub>	Annual arithmetic mean	2	20	40
	24-Hour maximum*	5	91	182
	3-Hour maximum*	25	512	700
NO <sub>2</sub>	Annual arithmetic mean	2.5	25	50

\*Maximum concentration not to be exceeded more than once per year at any one location.

Source: Section 62-204.260, F.A.C.

that affect increment. *Major* source baseline date means January 6, 1975, for PM (TSP/PM<sub>10</sub>) and SO<sub>2</sub> and February 8, 1988, for NO<sub>2</sub>. *Minor* source baseline date means the earliest date after the trigger date on which the first complete application was submitted by a major stationary source or major modification subject to the requirements of 40 CFR 52.21 or Section 62-212.400, F.A.C. The trigger dates are August 7, 1977, for PM (TSP/PM<sub>10</sub>) and SO<sub>2</sub> and February 8, 1988, for NO<sub>2</sub>.

The ambient impact analyses for Unit 6 are provided in Sections 6.0 (Methodology), 7.0 (PSD Class II areas), and 10.0 (PSD Class I areas).

#### **3.4.4 ADDITIONAL IMPACT ANALYSES**

Rule 62-212.400(8), F.A.C., requires additional impact analyses for three areas: associated growth, soils and vegetation impact, and visibility impairment. The level of analysis for each area should be commensurate with the scope of the project. A more extensive analysis would be conducted for projects having large emission increases than those that will cause a small increase in emissions.

The growth analysis generally includes:

- A projection of the associated industrial, commercial, and residential growth that will occur in the area.
- An estimate of the air pollution emissions generated by the permanent associated growth.
- An air quality analysis based on the associated growth emission estimates and the emissions expected to be generated directly by the new source or modification.

The soils and vegetation analysis is typically conducted by comparing projected ambient concentrations for the pollutants of concern with applicable susceptibility data from the air pollution literature. For most types of soils and vegetation, ambient air concentrations of criteria pollutants below the NAAQS will not result in harmful effects. Sensitive vege-



tation and emissions of toxic air pollutants could necessitate a more extensive assessment of potential adverse effects on soils and vegetation.

The visibility impairment analysis pertains particularly to Class I area impacts and other areas where good visibility is of special concern. A quantitative estimate of visibility impairment is conducted, if warranted by the scope of the project. Section 9.0 provides the additional impact analyses for Unit 6.

### **3.5 HAZARDOUS AIR POLLUTANT REQUIREMENTS**

Florida relies on the requirements of the CAA with respect to the regulation of hazardous (also known as toxic) air pollutants. These federal requirements include a comprehensive set of technology-based emission standards referred to as NESHAPs. These standards establish hazardous air pollutant emission limitations for a wide variety of industrial source categories. Recent NESHAPs (i.e., those adopted after the 1990 amendments to the CAA) reflect maximum achievable control technology (MACT). Section 4.2 provides a discussion of the NESHAPs program and its applicability to Unit 6.

## 4.0 STATE AND FEDERAL EMISSION STANDARDS

### 4.1 NEW SOURCE PERFORMANCE STANDARDS (NSPS)

Section 111 of the CAA, Standards of Performance of New Stationary Sources, requires EPA establish federal emission standards for source categories that cause or contribute significantly to air pollution. These standards are intended to promote use of the best air pollution control technologies, taking into account the cost of such technology and any other non-air quality, health, and environmental impact and energy requirements. These standards apply to sources that have been constructed or modified since the proposal of the standard. Since December 23, 1971, EPA has promulgated more than 75 standards. The NSPS are codified in 40 CFR 60.

Major components of Unit 6 include gasifier feedstock receiving, storage, handling, and preparation equipment; two gasifier trains; two CT/HRSG units; a sulfuric acid plant; and a 10-cell mechanical draft cooling tower. Ancillary equipment includes a flare (for combustion of syngas during gasifier startups/shutdowns and plant upsets); natural gas-fired auxiliary boiler (used only during gasifier startups), and three emergency diesel engines. Those NSPS that are potentially applicable to Unit 6 are discussed in the following sections.

#### 4.1.1 NSPS SUBPART Da—ELECTRIC STEAM GENERATING UNITS

NSPS Subpart Da is applicable to *electric utility steam generating units* that are capable of combusting more than 250 MMBtu/hr heat input of fossil fuel, and that commence construction after September 18, 1978. Combined cycle gas turbines are subject to NSPS Subpart Da, and not subject to NSPS Subpart KKKK (Standards of Performance for Stationary Combustion Turbines), if:

- The combined cycle gas turbine is capable of combusting more than 73 MW (250 MMBtu/hr) heat input of fossil fuel (either alone or in combination with any other fuel).
- The combined cycle gas turbine is designed and intended to burn fuels containing 50 percent (by heat input) or more solid-derived fuel not meeting the definition of natural gas on a 12-month rolling average basis.

- The combined cycle gas turbine commenced construction, modification, or reconstruction after February 28, 2005.

The Unit 6 CT/HRSG units will have a heat input capacity greater than 250 MMBtu/hr, meets the definition of an *electric utility steam generating unit*, and will commence construction after February 28, 2005. The Unit 6 CT/HRSG units are designed and intended to burn syngas for 50 percent (on a heat input basis) or more on a 12-month rolling average basis. Accordingly, the Unit 6 CT/HRSG units will be subject to the requirements of Subpart Da when syngas is combusted for 50 percent or more (on a heat input basis) during a 12-month rolling average basis.

NSPS Subpart Da specifies emission limitations, monitoring, reporting, and recordkeeping requirements for PM and opacity, SO<sub>2</sub>, NO<sub>x</sub>, and mercury. Applicable NSPS Subpart Da emission standards for the Unit 6 CT/HRSG units are summarized as follows:

- PM—0.14 lb/MWh gross energy output or 0.015 lb/MMBtu. Alternatively, units that commence construction after February 28, 2005, may elect to comply with a PM emission limit of 0.03 lb/MMBtu and a 99.9-percent reduction from uncontrolled emission rates. Opacity is limited to 20 percent (6-minute average), except for one 6-minute period per hour of no more than 27 percent.
- SO<sub>2</sub>—1.4 lb/MWh gross energy output on a 30-day rolling average basis, or 95-percent reduction on a 30-day rolling average basis.
- NO<sub>x</sub>—1.0 pound per megawatt (lb/MW) gross energy output, on a 30-day rolling average basis.
- Mercury— $20 \times 10^{-6}$  lb/MWh gross energy output, on a 12-month rolling average basis.
- The NSPS Subpart Da PM, NO<sub>x</sub>, and mercury emission limits do not apply during periods of startup, shutdown, or malfunction. The NSPS Subpart Da SO<sub>2</sub> applies at all times except emergency conditions.

The Unit 6 CT/HRSG units will be required to install continuous emissions monitor systems (CEMS) for SO<sub>2</sub>, NO<sub>x</sub>, and mercury pursuant to 40 CFR 60.49Da(b), (c), and (p) and a CEMS for oxygen or CO<sub>2</sub> pursuant to 40 CFR 60.49Da(d). Initial performance tests will be required to demonstrate compliance with the NSPS Subpart Da PM, opacity, NO<sub>x</sub>, and SO<sub>2</sub> emission standards in accordance with the test methods specified in 40 CFR 60.48Da.

Compliance with the NO<sub>x</sub> and SO<sub>2</sub> standards will be determined based on a 30-day rolling average as measured by the NO<sub>x</sub> and SO<sub>2</sub> CEMS. Compliance with the mercury standard will be determined on a 12-month rolling average basis as measured by the mercury CEMS.

When firing syngas, the Unit 6 CT/HRSG units will have emissions well below the NSPS Subpart Da emission standards, and will comply with the applicable requirements of NSPS Subpart Da.

#### **4.1.2 NSPS SUBPART Db—INDUSTRIAL-COMMERCIAL-INSTITUTIONAL STEAM GENERATING UNITS**

The Unit B auxiliary boiler will have a heat input capacity greater than 100 MMBtu/hr, meets the definition of a *steam generating unit*, and will commence construction after June 19, 1984. The Unit B auxiliary boiler will therefore be subject to the applicable requirements of NSPS Subpart Db—Standards of Performance for Industrial-Commercial-Institutional Steam Generating Units.

The Unit 6 auxiliary boiler will be fired exclusively with pipeline quality natural gas and will operate for no more than 876 hr/yr; (i.e., will have an annual capacity factor of 10 percent or less). For such units constructed after July 9, 1997, Subpart Db does not contain any applicable emission limitations.

#### **4.1.3 NSPS SUBPART H—SULFURIC ACID PLANTS**

Per 40 CFR 60.81(a), NSPS Subpart H does not apply to facilities that convert sulfur compounds to H<sub>2</sub>SO<sub>4</sub> mist primarily as a means of preventing emissions to the atmos-

phere of SO<sub>2</sub> or other sulfur compounds. The Unit 6 sulfuric acid plant serves as an emission control system to prevent emissions of SO<sub>2</sub> and H<sub>2</sub>SO<sub>4</sub> mist associated with the syngas acid gas removal cleanup system. Accordingly, the Unit 6 sulfuric acid plant is not subject to the requirements of NSPS Subpart H.

#### **4.1.4 NSPS SUBPART Y—COAL PREPARATION PLANTS**

NSPS Subpart Y is applicable to coal preparation plants that process more than 200 tpd of coal and that are constructed after October 24, 1974. Specific facilities addressed by Subpart Y include thermal dryers, pneumatic coal-cleaning equipment, coal processing and conveying equipment (including breakers and crushers), coal storage systems, and coal transfer and loading systems. *Coal preparation plants* are defined as facilities that prepare coal by one or more of the following processes: breaking, crushing, screening, wet or dry cleaning, and thermal drying.

A detailed description of the Unit 6 gasifier feedstock (i.e., coal, petcoke, and biomass) receiving, storage, handling, and grinding process was previously provided in Section 2.0. Since Unit 6 will process more than 200 tpd of coal, the gasifier coal feedstock processing, conveying, storage, transfer, and loading systems will be subject to the requirements of NSPS Subpart Y.

NSPS Subpart Y, 40 CFR 60.252, contains separate PM standards for: thermal dryers, pneumatic coal cleaning equipment, and coal processing and conveying equipment; coal storage systems; or coal transfer and loading systems. Unit 6 will not include a thermal dryer or pneumatic coal cleaning equipment. Accordingly, visible emissions from the Unit 6 coal processing and conveying equipment, coal storage systems, and coal transfer and loading systems are limited to less than 20-percent opacity as specified by NSPS Subpart Y, 40 CFR 60.252(c). Initial opacity performance tests using EPA Reference Method 9 will be required per the general provisions of NSPS Subpart A, 40 CFR 60.8, and the specific provisions of NSPS Subpart Y, 40 CFR 60.254(a) and (b)(2).

The Unit 6 coal handling and processing equipment will comply with the applicable requirements of NSPS Subpart Y.

#### **4.1.5 NSPS SUBPART HHHH—EMISSION GUIDELINES AND COMPLIANCE TIMES FOR COAL-FIRED ELECTRIC STEAM GENERATING UNITS**

NSPS Subpart HHHH establishes the model rule comprising general provisions and the designated representative, permitting, allowance, and monitoring provisions for the State Mercury Budget Trading Program, under Section 111 of the CAA and 40 CFR 60.24(h)(6), as a means of reducing national mercury emissions. Florida has adopted NSPS Subpart HHHH by reference in Section 62-204.800, F.A.C., subject to the provisions set forth at Section 62-296.480, F.A.C. This latter rule provides Florida's implementation of the Federal Clean Air Mercury Rule (CAMR).

Unit 6 will comply with the applicable requirements of NSPS Subpart HHHH.

#### **4.1.6 NSPS SUBPART IIII – STATIONARY COMPRESSION IGNITION INTERNAL COMBUSTION ENGINES**

NSPS Subpart IIII is applicable to owners and operators of stationary compression ignition (CI) internal combustion engines (ICE) that commence construction after July 11, 2005, where the CI ICE are manufactured after April 1, 2006 (and are not fire pump engines), or manufactured after July 1, 2006 (for certified National Fire Protection Association fire pump engines).

NSPS Subpart IIII specifies emission limitations, monitoring, reporting, and recordkeeping requirements for NO<sub>x</sub>, CO, nonmethane hydrocarbons (NMHC), and PM. Applicable NSPS Subpart IIII emission standards for the Unit 6 emergency diesel generator and diesel-driven firewater pump CI ICEs are summarized as follows:

- Owners and operators of 2007 model year and later emergency stationary CI ICE with a displacement of less than 30 liters per cylinder that are not fire pump engines must comply with the emission standards for new nonroad CI engines in 40 CFR 60.4202, for all pollutants, for the same model year and maximum engine power for their 2007 model year and later emergency stationary CI ICE.

- Owners and operators of fire pump engines with a displacement of less than 30 liters per cylinder must comply with the emission standards in Table 4 to NSPS Subpart IIII, for all pollutants.

The Unit 6 emergency generator and firewater pump diesel engines will comply with the applicable requirements of NSPS Subpart IIII.

#### **4.1.7 NSPS SUBPART KKKK—STATIONARY COMBUSTION TURBINES**

Subpart KKKK establishes emission limits for CT/HRSG units that commenced construction after February 18, 2005, and that have a heat input at peak load equal to greater than 10.7 gigajoules (10 MMBtu/hr) based on the HHV of the fuel. Stationary CTs at IGCC electric utility steam generating units that are subject to NSPS Subpart Da are exempt from Subpart KKKK.

Although designed and intended to primarily combust syngas, the Unit 6 CT/HRSG units will be capable of firing natural gas for up to 8,760 hr/yr. Accordingly, the Unit 6 CT/HRSG units will be subject to the applicable requirements of Subpart KKKK during those periods when the units are not subject to Subpart Da; (i.e., during periods when syngas is combusted for less than 50 percent [on a heat input basis] during a 12-month rolling average basis).

NSPS Subpart KKKK specifies emission limitations, monitoring, reporting, and record-keeping requirements for NO<sub>x</sub> and SO<sub>2</sub>. Applicable NSPS Subpart KKKK emission standards for the Unit 6 CT/HRSG units are summarized as follows:

- NO<sub>x</sub>—15 ppmvd at 15 percent oxygen, or 0.43 lb/MWh gross energy output.
- SO<sub>2</sub>—0.90 lb/MWh gross energy output, or 0.060 lb/MMBtu.

When firing natural gas, the Unit 6 CT/HRSG units will have emissions well below the NSPS Subpart KKKK emission standards, and will comply with the applicable requirements of NSPS Subpart KKKK.

#### **4.2 NATIONAL EMISSION STANDARDS FOR HAZARDOUS AIR POLLUTANTS (NESHAPs)**

The provisions of the CAA that address the control of HAP emissions, or air toxics, are found in Section 112. Section 112 of the CAA includes provisions for the promulgation of NESHAPs, or MACT standards, as well as several related programs to enhance and support the NESHAPs program. Section 112 requires EPA to publish and regularly update (at least every 8 years) a list of all categories and subcategories of major and area sources that emit HAPs. The Section 112(c) list of source categories was initially published in the Federal Register (FR) on July 16, 1992, and has been periodically revised thereafter. EPA must promulgate regulations establishing emission standards (NESHAPs) for each category or subcategory of major sources and area sources of HAPs that are listed pursuant to Section 112(c). The standards must require the maximum degree of emission reduction that EPA determines to be achievable by each particular source category. Different criteria for MACT apply for new and existing sources. Less stringent standards, known as generally available control technology (GACT) standards, are allowed at the EPA Administrator's discretion for area sources.

On March 29, 2005, EPA issued a final agency action delisting electric utility steam generating units from the CAA Section 112(c) source category list. Instead of regulating electric utility steam generating unit HAP emissions under the NESHAPs program, EPA elected to limit emissions of mercury (the only electric utility steam generating unit HAP considered by EPA to warrant regulation) from coal-fired units using the authority of the NSPS program as described previously in Section 4.1.1 (i.e., NSPS Subpart Da). Accordingly, the Unit 6 CT/HRSG units are not subject to any 40 CFR 61 or 63 NESHAPs.

Although electric utility steam generating units are no longer included on the Section 112(c) list, the source category list presently includes stationary reciprocating internal combustion engines (RICE) and industrial/commercial/institutional boilers and process heaters. As required by Section 112 of the CAA, EPA promulgated a final NESHAPs for stationary RICE (40 CFR 63, Subpart ZZZZ) on June 15, 2004, and a final NESHAPs for industrial/commercial/institutional boilers and process heaters (40 CFR 63, Subpart DDDDD) on September 13, 2004.



However, the 40 CFR 63 NESHAPS are only applicable to *major* HAP sources (i.e., facilities that have potential emissions of any individual HAP of 10 tpy or more, and potential emissions of total HAPs of 25 tpy or more). The PPS, including Unit 6, will have potential HAP emission rates below these thresholds and, therefore, is a minor source of HAPs. Accordingly, the 40 CFR 63 NESHAPS are not applicable to the PPS emission sources, including Unit 6.

### **4.3 ACID RAIN PROGRAM**

The overall goal of the acid rain program (ARP) is to achieve significant environmental and public health benefits through reductions in emissions of SO<sub>2</sub> and NO<sub>x</sub>, the primary causes of acid rain. To achieve this goal at the lowest cost to society, the program employs both traditional and innovative, market-based approaches for controlling air pollution. In addition, the program encourages energy efficiency and pollution prevention.

Title IV of the CAA sets a goal of reducing annual SO<sub>2</sub> emissions by 10 million tons below 1980 levels. To achieve these reductions, the law required a two-phase tightening of the restrictions placed on fossil fuel-fired power plants. Phase I began in 1995 and affected 263 units at 110 mostly coal-burning electric utility plants located in 21 eastern and midwestern states. An additional 182 units joined Phase I of the program as substitution or compensating units, bringing the total of Phase I affected units to 445. Phase II, which began in the year 2000, tightened the annual emissions limits imposed on these large, higher emitting plants and also set restrictions on smaller, cleaner plants fired by coal, oil, and gas, encompassing more than 2,000 units in all. The program affects existing utility units serving generators with an output capacity of greater than 25 MW and all new utility units.

For SO<sub>2</sub>, the ARP introduced an allowance trading system that harnesses the incentives of the free market to reduce pollution. Under this cap-and-trade program, affected existing utility units (i.e., those in operation prior to November 15, 1990) are allocated allowances based on their historical fuel consumption and a specific emission rate. Each allowance permits a unit to emit 1 ton of SO<sub>2</sub> during or after a specified year. For each ton of SO<sub>2</sub>

emitted in a given year, one allowance is retired, that is, it can no longer be used. Allowances may be bought, sold, or banked. Anyone may acquire allowances and participate in the trading system. However, regardless of the number of allowances a source holds, it may not emit at levels that would violate federal or state limits set under Title I of the CAA to protect public health. During Phase II of the program (now in effect), the CAA set a permanent ceiling (or cap) of 8.95 million allowances for total annual SO<sub>2</sub> allowance allocations to utilities. This cap firmly restricts emissions and ensures that environmental benefits will be achieved and maintained. New utility units (i.e., those that commence operation on and after November 15, 1990) are not allocated any SO<sub>2</sub> allowances and must obtain such allowances annually from the ARP SO<sub>2</sub> allowance market in amounts equal to their actual SO<sub>2</sub> emission rates.

The CAA also required a 2-million-ton reduction in NO<sub>x</sub> emissions by the year 2000. A significant portion of this reduction has been achieved by coal-fired utility boilers that will be required to install low NO<sub>x</sub> burner technologies and to meet new emissions standards. The ARP NO<sub>x</sub> emission reduction requirements are only applicable to existing utility units (i.e., those in operation prior to November 15, 1990).

The Unit 6 CT/HRSG units will be subject to the ARP since they will be *new utility units* (i.e., will commence operation after November 15, 1990) and will serve a generator that produces electricity for sale. As noted previously, new utility units do not receive any SO<sub>2</sub> allowance allocations. Accordingly, Tampa Electric will need to annually obtain SO<sub>2</sub> allowances from the ARP SO<sub>2</sub> allowance market in amounts equal to the Unit 6 CT/HRSG unit's actual SO<sub>2</sub> emission rates. The NO<sub>x</sub> component of the ARP does not apply to new utility units.

#### **4.4 CLEAN AIR INTERSTATE RULE**

On March 10, 2005, EPA issued the final Clean Air Interstate Rule (CAIR). The objective of CAIR is to assist states with PM<sub>2.5</sub> and 8-hour ozone nonattainment areas to achieve attainment by reducing precursor emissions at sources located in 28 states (including Florida) situated upwind of these nonattainment areas. Based on regional dispersion modeling, EPA determined that these 28 upwind states significantly contribute to PM<sub>2.5</sub> and

8-hour ozone nonattainment in downwind areas. Florida emission sources are projected to significantly contribute to PM<sub>2.5</sub> nonattainment areas located in Georgia (Macon and Atlanta) and Alabama (Birmingham) and to an 8-hour ozone nonattainment area in Georgia (Atlanta).

The CAIR reductions of precursor emissions address annual SO<sub>2</sub> and NO<sub>x</sub> emissions (for reductions in annual and daily average ambient PM<sub>2.5</sub> impacts) and ozone season (May through September) NO<sub>x</sub> emissions (for reductions in 8-hour average ambient ozone impacts). The SO<sub>2</sub> and NO<sub>x</sub> reductions will be implemented by means of a regional two-phase cap-and-trade program. For SO<sub>2</sub>, the first cap begins in calendar year 2010 and extends through 2014. For NO<sub>x</sub>, the first cap begins in calendar year 2009 and also extends through 2014. The second phase cap for both pollutants becomes effective in calendar year 2015 and thereafter. The SO<sub>2</sub> caps will reduce current ARP SO<sub>2</sub> emissions by 50 percent in Phase I and by 65 percent in Phase II. The NO<sub>x</sub> caps reflect NO<sub>x</sub> emission rates of 0.15 and 0.125 lb/MMBtu for the first and second phase caps, respectively.

For each phase cap, CAIR assigns SO<sub>2</sub> and NO<sub>x</sub> emission budgets (in units of tpy and tons per ozone season) to each affected upwind state. These state emission budgets were developed by EPA based on the application of cost-effective control technologies (i.e., flue gas desulfurization [FGD]) for SO<sub>2</sub> and SCR for NO<sub>x</sub>. The affected states were required to submit revised state implementation plans (SIPs) within 18 months (i.e., by September 11, 2006) for EPA review and approval. Florida's proposed SIP revisions implementing CAIR were submitted to EPA Region 4 on March 16, 2007, for review and approval in accordance with EPA's abbreviated SIP approval process. The SIPs will provide details as to the procedures that will be used to allocate the state NO<sub>x</sub> and SO<sub>2</sub> budgets to individual sources. On August 2, 2007, EPA proposed to approve Florida's CAIR SIP revisions.

Following SIP approval and allocation of the state SO<sub>2</sub> and NO<sub>x</sub> budgets to individual emission sources, emission units at these sources must possess sufficient SO<sub>2</sub> and NO<sub>x</sub> allowances such that actual emissions (as measured by CEMS) do not exceed the allocations for each control period beginning in 2009 (for NO<sub>x</sub>) and 2010 (for SO<sub>2</sub>). Sources that have actual emissions in excess of their allocation will need to reduce actual emission rates or pur-

chase additional allowances on the open market. Emission sources that have surplus allowances may bank the allowances for use in any future control period or sell the surplus allowances on the open market.

Florida has adopted EPA's 40 CFR 96 CAIR NO<sub>x</sub> and SO<sub>2</sub> Trading Programs for State Implementation Plans by reference in Section 62-204.800, F.A.C. Florida's implementation of the Federal CAIR is set forth at Section 62-296.470, F.A.C.

EPA's model NO<sub>x</sub> trading program includes provisions for allocating NO<sub>x</sub> allowances to new utility units (those that are placed in service in 2001 or later) such as the Unit 6 CT/HRSG units (i.e., a new source set-aside). Similar to the ARP, there are no provisions for a new source set-aside with respect to CAIR SO<sub>2</sub> allowances. For NO<sub>x</sub> allowances, new units will be allocated allowances from the new source set-aside until they have established a baseline and are included in the shared pool. NO<sub>x</sub> allowance allocations from the new source set-aside pool will be made to new utility units on a pro-rata basis.

#### **4.5 CLEAN AIR MERCURY RULE**

On March 15, 2005, EPA issued the final CAMR. The purpose of CAMR is to reduce national coal-fired power plant mercury emissions from the current level of 48 to 15 tpy by means of a two-phase cap-and trade program. The first phase national mercury cap (with a cap of 38 tpy) becomes effective in 2010 while the second 15-tpy cap becomes effective in 2018 and thereafter.

CAMR also establishes stack mercury emission standards applicable to new sources (i.e., those constructed, modified, or reconstructed after January 30, 2004.) The electric utility steam generating unit stack mercury emissions applicable to the Unit 6 CT/HRSG units (i.e., the NSPS Subpart Da mercury emission standards) were previously discussed in Section 4.1.1.

Similar to CAIR, CAMR assigns mercury budgets (in units of tpy) to each state for each phase cap. The first phase mercury cap represents the cobenefits that will be achieved by CAIR (i.e., installation of FGD and SCR controls). The second phase mercury cap is

based on the cumulative effect of FGD/SCR cobenefits and on EPA projections regarding the availability and removal efficiency of future mercury controls (e.g., activated carbon injection [ACI]).

The NSPS program serves as the regulatory authority for CAMR. Accordingly, the revisions to NSPS Subpart Da were effective upon proposal (i.e., January 30, 2004). CAMR also includes a new NSPS, Subpart HHHH, which contains EPA's model mercury trading program. Under the terms of revised NSPS Subpart Da, states must submit plans by November 17, 2006, that address the state electrical generating unit mercury caps for 2010 and 2018 for EPA review and approval. The state plans will provide details as to the procedures that will be used to allocate the state mercury budgets to individual coal-fired utility units. For each control period, sufficient mercury allowances must be held to cover the actual mercury emissions for all mercury budget units at a source. Although mercury allowances will be allocated on a unit-by-unit basis, compliance with the CAMR mercury allowance program is determined on a plant-wide basis.

As described previously for the CAIR state SO<sub>2</sub> and NO<sub>x</sub> budgets, following SIP approval and allocation of the state mercury budgets to individual emission sources, these sources must possess sufficient mercury allowances to cover their actual emission rates (as continuously measured either by CEMS or sorbent trap monitoring systems) for each control period beginning in 2010. Emission sources that have actual mercury emissions in excess of their allocation will need to reduce actual emission rates or purchase additional allowances. Emission sources that have surplus allowances may bank the allowances for use in any future control period or sell the surplus allowances. Revised SIPs that address the CAMR requirements were required to be submitted to EPA by November 17, 2006.

Florida has adopted NSPS Subpart HHHH by reference in Section 62-204.800, F.A.C., subject to the provisions set forth at Section 62-296.480, F.A.C. This latter rule provides Florida's implementation of the Federal CAMR. Florida's proposed SIP revisions implementing CAMR were submitted to EPA Region 4 on December 29, 2006.

In summary, the Unit 6 CT/HRSG units will need to comply with the NSPS Subpart Da stack mercury emission limits for new electric utility steam generating units as well as the mercury cap-and-trade program in accordance with Section 62-296.480, F.A.C.

#### **4.6 FLORIDA EMISSION STANDARDS**

FDEP emission standards for stationary sources are contained in Chapter 62-296, Stationary Sources—Emission Standards, F.A.C. General pollutant emission limit standards are included in Section 62-296.320, F.A.C. Sections 62-296.401 through 62-296.418, F.A.C., specify emission standards for 18 categories of sources. Sections 62-296.470 and 62-296.480 address CAIR and CAMR requirements, respectively. Sections 62-296.500 through 62-296.570, F.A.C., establish reasonably available control technology (RACT) requirements for VOC and NO<sub>x</sub> emitting facilities. RACT requirements for lead and PM are found in Sections 62-296.600 through 62-296.605 and 62-296.700 through 62-296.712, F.A.C., respectively. Section 62-204.800, F.A.C. adopts federal regulations, including NSPSs, by reference.

With respect to Unit 6, the general Rule 62-296.320(4)(b), F.A.C., visible emission limitation of 20-percent opacity will apply to all point (i.e., stack) emission sources. Reasonable precautions to prevent unconfined PM emissions (e.g., feedstock storage piles) will be required pursuant to Rule 62-296.320(4)(c), F.A.C.

Section 62-296.405, Fossil Fuel Steam Generators with More Than 250 MMBtu/hr Heat Input, F.A.C., will apply to the Unit 6 auxiliary boiler. This section requires compliance with applicable NSPS requirements; e.g., NSPS Subpart Da.

Section 62-296.402, Sulfuric Acid Plants, F.A.C., will apply to the Unit 6 sulfuric acid plant. For new sulfuric acid plants, this rule contains the following emission limits:

- Opacity—Less than or equal to 10-percent opacity.
- SO<sub>2</sub>—Four pounds per ton of 100 percent acid produced.
- Acid Mist—0.15 pounds per ton of 100 percent acid produced.

None of the remaining emission standards specified in Sections 62-296.401 through 62-296.418, F.A.C., are applicable to Unit 6. The VOC, NO<sub>x</sub>, lead, and PM RACT requirements do not apply to emission units that are subject to NSR permitting, and therefore are not applicable to Unit 6.

NSPS Subparts Da (for the CT/HRSG units when syngas is combusted for 50 percent or more [on a heat input basis] during a 12-month rolling average basis), Db (for the auxiliary boiler), Y (for coal handling and processing equipment), HHHH (for the CT/HRSG units mercury cap-and-trade program), IIII (for the emergency diesel engines), and KKKK (for the CT/HRSG units when syngas is combusted for less than 50 percent [on a heat input basis] during a 12-month rolling average basis) will be applicable to Unit 6.

The Unit 6 emission sources will comply with all of the applicable Florida emission standards noted above.

## 5.0 BEST AVAILABLE CONTROL TECHNOLOGY

### 5.1 METHODOLOGY

BACT analyses were performed in accordance with the EPA top-down method. As previously described in Section 3.4.1, the top-down methodology consists of the following five steps:

- Step 1—Identify all available control technologies for each PSD pollutant subject to review.
- Step 2—Eliminate all technically infeasible control technologies.
- Step 3—Rank the remaining control technologies by control effectiveness.
- Step 4—Evaluate the feasible control technologies, beginning with the most efficient, with respect to economic, energy, and environmental impacts.
- Step 5—Select as BACT the most effective control technology that is not rejected based on adverse economic, environmental, and/or energy impacts.

The first step in the top-down BACT procedure is the identification of all available control technologies. Alternatives considered included process designs and operating practices that reduce the formation of emissions, postprocess stack controls that reduce emissions after they are formed, and combinations of these two control categories. Sources of information used to identify control alternatives included:

- EPA RACT/BACT/lowest achievable emission rate (LAER) Clearinghouse (RBLC) via the RBLC Information system database.
- Recent permits for IGCC power projects.
- FDEP BACT determinations for similar facilities.
- ECT experience for similar projects.

Following the identification of available control technologies, the next step in the analysis is to determine which technologies may be technically infeasible. Technical feasibility was evaluated using the criteria contained in Chapter B of the EPA NSR Workshop Manual (EPA, 1990a). The third step in the top-down BACT process is the ranking of the



remaining technically feasible control technologies from high to low in order of control effectiveness.

If the top-case control technology with the highest removal efficiency is selected as BACT, an assessment of collateral environmental impacts is conducted to determine whether such impacts would deem the control technology unacceptable. If the most efficient control technology is not selected as BACT, an assessment of energy, environmental, and economic impacts is then performed. If assessed, the economic analysis employed the procedures found in the Office of Air Quality Planning and Standards (OAQPS) *Air Pollution Control Cost Manual*, Sixth Edition (EPA, 2002).

The fifth and final step is the selection of a BACT emission limitation corresponding to the most stringent, technically feasible control technology that was not eliminated based on adverse energy, environmental, or economic grounds.

As defined by Rule 62-210.200(40), F.A.C., BACT emission limitations must be no less stringent than any applicable NSPS (40 CFR 60), NESHAP (40 CFR 61 and 63), and FDEP emission standards (Chapter 62-296, Stationary Sources—Emission Standards, F.A.C.). The NSPS, NESHAPs, and Florida emission standards applicable to Unit 6 were previously discussed in Sections 4.1, 4.2, and 4.6, respectively. The BACT emission limitations proposed for Polk Unit 6 are more stringent than the applicable federal and state standards cited in these sections.

As shown in Table 3-2 of Section 3.0, annual Unit 6 emissions of NO<sub>x</sub>, CO, PM/PM<sub>10</sub>, SO<sub>2</sub>, and H<sub>2</sub>SO<sub>4</sub> mist are projected to exceed the PSD significance rates for these pollutants. A BACT analysis is therefore required for each new emission source that will emit these pollutants. Accordingly, BACT analyses were conducted for the following Polk Unit 6 emission sources:

- CT/HRSG.
- Auxiliary boiler.
- Sulfuric acid plant.

- Emergency firewater pump and generator diesel engines.
- Mechanical draft cooling tower.
- Gasifier feedstock and byproduct material storage and handling systems.

The CT/HRSGs, auxiliary boiler, and emergency diesel engines will emit pollutants associated with fuel combustion including NO<sub>x</sub>, CO, SO<sub>2</sub>, PM/PM<sub>10</sub>, and H<sub>2</sub>SO<sub>4</sub> mist. BACT analyses were therefore conducted for each of these combustion-related PSD pollutants for the CT/HRSGs, auxiliary boiler, and emergency diesel engines. The mechanical draft cooling tower and gasifier feedstock and byproduct material storage and handling systems will only emit PM/PM<sub>10</sub>. The BACT analysis for these emission sources was therefore confined to PM/PM<sub>10</sub>. The BACT analysis for the sulfuric acid plant was limited to SO<sub>2</sub>/H<sub>2</sub>SO<sub>4</sub> mist emissions.

The principal Unit 6 emission sources are the CT/HRSGs. Emissions from the CT/HRSGs comprise 90 percent of total estimated Unit 6 project annual criteria emissions. Accordingly, the primary emphasis of the BACT analysis conducted for Unit 6 was directed to the CT/HRSGs. The CT/HRSGs will be equipped with a comprehensive state-of-the-art emission control system that includes syngas cleanup systems to remove particulate, sulfur, mercury, and nitrogenous compounds; and diluent injection, syngas moisturization, and SCR for control of NO<sub>x</sub>. This extensive system of emission control equipment will reduce emissions of the two primary pollutants (SO<sub>2</sub> and NO<sub>x</sub>) to levels comparable to the lowest rates that have been proposed for any IGCC unit in the United States, and lower than the BACT limits in any permitted pulverized coal utility boiler.

Control technology analyses using the five-step top-down BACT method are provided for in Section 5.3 (for NO<sub>x</sub>), Section 5.4 (for SO<sub>2</sub> and H<sub>2</sub>SO<sub>4</sub> mist), Section 5.5 (for CO), and Section 5.6 (for PM/PM<sub>10</sub>). SO<sub>2</sub> and H<sub>2</sub>SO<sub>4</sub> mist are addressed in one section since these pollutants have a common origin (i.e., fuel sulfur and products of incomplete fuel combustion) and similar available control technologies.

## **5.2 EVALUATION OF ALTERNATIVE ELECTRICAL GENERATION TECHNOLOGIES**

As discussed in Section 5.1, the first step in a BACT determination process is to identify all available control technologies that could potentially be used to minimize the emissions for the pollutant under evaluation. Control technologies typically considered in a BACT analysis include process modifications that reduce the formation of pollutants and postprocess emission control systems that reduce emissions after the pollutants are formed. An example of the former is the use of low-NO<sub>x</sub> burners to alter the combustion process and reduce the formation of NO<sub>x</sub>. The use of SCR to reduce NO<sub>x</sub> following its formation in the combustion process is an example of a postprocess emission control system. These types of control technologies, when applicable, are appropriately considered in a BACT analysis.

Evaluation of process alternatives that would involve completely “redefining the design” of the proposed process are not required to be considered (1990 *Draft New Source Review Workshop Manual*, Section IV.A.3). Alternative electrical generating processes, such as natural gas-fired or pulverized coal plants, represent completely different power generation plant designs compared to the IGCC technology selected for Unit 6. While all electrical generation technologies generate electricity, the technical basis for the IGCC technology is substantially different from a natural gas-fired or traditional coal-fired plant. Since a natural gas-fired combined-cycle facility or coal-fired electrical generating plant represents a completely different process compared to IGCC technology, a BACT analysis of these alternative electrical generation technologies is not required because these process alternatives would “redefine the design” of the Unit 6 Project.

## **5.3 BACT ANALYSIS FOR NO<sub>x</sub>**

### **5.3.1 CT/HRSG**

Essentially all CT NO<sub>x</sub> emissions originate as nitric oxide (NO). NO generated by the CT combustion process is subsequently further oxidized downstream of the CT (i.e., within the HRSG) or in the atmosphere to the more stable NO<sub>2</sub> molecule. NO<sub>x</sub> emissions from combustion sources are formed by one of three mechanisms: thermal, fuel, and prompt.

Unit 6 CT/HRSG unit NO<sub>x</sub> emissions will primarily be the result of thermal NO<sub>x</sub> formation. Thermal NO<sub>x</sub> is formed by the high-temperature reaction of nitrogen with oxygen. The amount of thermal NO<sub>x</sub> formed is primarily a function of combustion temperature and residence time, air/fuel ratio, and, to a lesser extent, combustion pressure. Thermal NO<sub>x</sub> increases exponentially with increases in temperature and linearly with increases in residence time as described by the Zeldovich mechanism.

Fuel NO<sub>x</sub> arises from the oxidation of chemically bound nitrogen contained in the fuel. In contrast to thermal NO<sub>x</sub>, fuel NO<sub>x</sub> formation does not vary appreciably with combustion variables such as temperature or residence time. The conversion of fuel-bound nitrogen (FBN) to NO<sub>x</sub> depends on the bound nitrogen content of the fuel. Natural gas normally has very little organically bound nitrogen. Although the gasifier feedstock (i.e., coal and petcoke) contains a significant amount of FBN, the Unit 6 entrained flow oxygen-blown gasifiers will operate in a reducing atmosphere resulting in the majority of feedstock FBN converting to diatomic nitrogen (N), with minor amounts of ammonia (NH<sub>3</sub>) and hydrogen cyanide (HCN). The ammonia and HCN nitrogenous compounds are subsequently removed by the syngas cleaning processes (e.g., syngas water scrubber and condensate ammonia stripper). Accordingly, the FBN content of the treated syngas will be insignificant, resulting in negligible fuel NO<sub>x</sub> production in the Unit 6 CT/HRSG units.

Prompt NO<sub>x</sub> is formed by the relatively fast reaction between nitrogen, oxygen, and hydrocarbon radicals. Prompt NO<sub>x</sub> formation is important in lower temperature combustion processes but is much less important compared to thermal NO<sub>x</sub> formation at the high temperatures in the CT.

For natural gas combustion, the primary contributor to NO<sub>x</sub> in the exhaust gas is thermal NO<sub>x</sub>. Presently, there are no combustion processes available to control fuel NO<sub>x</sub> emissions. For this reason, the gas turbine Subpart GG NSPS, for example, contains an allowance for fuel NO<sub>x</sub>.

### **5.3.1.1 Available NO<sub>x</sub> Control Technologies**

Available technologies for controlling NO<sub>x</sub> emissions from CC CT/HRSG units include combustion process modifications and postcombustion exhaust gas treatment systems. A listing of available technologies for each of these categories follows:

#### **Combustion Process Modifications:**

- Combustion temperature moderation through dilution.
  - Water injection.
  - Steam injection.
  - Saturation/moisturization of syngas with water vapor.
  - Nitrogen injection.
- Dry low-NO<sub>x</sub> (DLN) combustor design.
- XONON®.

#### **Postcombustion Exhaust Gas Treatment Systems:**

- Selective noncatalytic reduction (SNCR).
- Nonselective catalytic reduction (NSCR).
- SCR.
- EMx™ (formerly SCONOx™).

A description of each of the listed control technologies is provided in the following subsections.

#### **Combustion Temperature Moderation Through Dilution**

Adding an inert gas or water vapor to the fuel gas or injecting water, steam or nitrogen into the primary combustion zone of advanced combustors of a CT reduces the formation of thermal NO<sub>x</sub> by decreasing the peak combustion temperature. The maximum amount of gas or water that can be added depends on the CT combustor design and the heating value of the fuel. Excessive rates of addition will cause flame instability, combustor dynamic pressure oscillations, thermal stress (cold spots), and increased emissions of CO and VOCs due to combustion inefficiency. Accordingly, the extent to which combustion temperature moderation can reduce NO<sub>x</sub> emissions is limited and depends on turbine combustor design. For a given turbine design, the maximum diluent-to-fuel ratio (and

maximum NO<sub>x</sub> reduction) will occur up to the point where cold spots and flame instability adversely affect safe, efficient, and reliable operation of the turbine.

Water injection acts as a heat sink to decrease the peak flame temperature by absorbing heat necessary to: (a) vaporize the water (latent heat of vaporization), and (b) raise the vaporized water temperature to the combustion temperature (heat capacity). High purity water must be employed to prevent turbine corrosion and deposition of solids on the turbine blades. Although water injection provides a large heat sink, it is not favored for base loaded units because its long-term use is more damaging to the combustion hardware than other approaches, since water injection is more inclined to produce combustor dynamic pressure oscillations leading to combustion hardware failure.

Similar to water injection, the addition of a diluent such as nitrogen and/or moisture to the fuel gas or the injection of nitrogen or steam into the combustors reduces the formation of thermal NO<sub>x</sub> by decreasing the peak combustion temperature. Their effectiveness in reducing the peak flame temperature is related to their heat capacity. Since they are already in the vapor phase, unlike injected water, they do not contribute a latent heat of vaporization to the heat sink. Accordingly, more steam or nitrogen is required to achieve a specified level of NO<sub>x</sub> reduction in comparison to water injection. Typical water injection rates range from 0.3 to 1.0 pound per pound of fuel, and steam injection rates are typically about twice as much.

Diluent nitrogen addition is often employed for CTs fired with syngas derived from oxygen-blown gasification processes since nitrogen is available from the air separation plant which provides oxygen to the gasifier. Diluent injection has also been employed on natural gas-fired CTs. Saturation (moisturization of the syngas fuel) is also often employed for CTs fired with syngas since gasification processes generate low-level heat which can be used to provide the water vapor for moisturization more efficiently than generating steam for steam injection.

It should be noted that another inert gas, CO<sub>2</sub> also plays an important role in NO<sub>x</sub> suppression. CO<sub>2</sub> has a higher molar heat capacity than either steam/water vapor or nitrogen, so it is more effective than either of these in lowering combustion temperature and suppressing NO<sub>x</sub> formation. The syngas from the GE gasification process contains between 10 percent and 20 percent CO<sub>2</sub>, referred to as “native CO<sub>2</sub>”. As the native CO<sub>2</sub> is reduced in the syngas, additional steam and/or nitrogen must be added to achieve the same level of NO<sub>x</sub> suppression. All sulfur removal systems also remove some of this native CO<sub>2</sub>. Deeper sulfur removal leads to co-adsorption and removal of more of the native CO<sub>2</sub>. Consequently, attempts to reduce sulfur levels in the syngas fuel simultaneously reduce the amount of CO<sub>2</sub> in the clean fuel gas which results in higher NO<sub>x</sub> production, all other things being equal. Additional moisturization or steam or nitrogen injection can only offset this loss of CO<sub>2</sub> up to the point where combustion instability begins to occur.

In Polk Unit 6, virtually all the available diluent nitrogen from the air separation plant will be injected into the CT combustors and the syngas will be saturated with up to 14 percent water vapor prior to combustion. Direct injection of additional water or steam is not feasible since the resulting heat content of the syngas would be too low to sustain safe, efficient, and reliable operation of the CT. Syngas moisture saturation and diluent nitrogen injected into the combustors along with the native CO<sub>2</sub> in the syngas can typically reduce CT NO<sub>x</sub> exhaust concentrations to levels consistent with achieving permit limits of 15 ppmvd, corrected to 15 percent oxygen. The use of water or steam injection in diffusion flame combustors firing natural gas can typically achieve NO<sub>x</sub> exhaust concentrations of 25 ppmvd, corrected to 15-percent oxygen.

#### **Dry Low-NO<sub>x</sub> Combustor Design**

A number of CT vendors have developed DLN combustors that premix turbine fuel and air prior to combustion in the primary zone. Use of a premix burner results in a homogeneous air/fuel mixture without an identifiable flame front. For this reason, the peak and average flame temperatures are the same, causing a decrease in thermal NO<sub>x</sub> emissions in comparison to a conventional diffusion burner.

DLN combustor technology was developed for natural gas-fired CTs and is not currently available for CT fired with syngas due to the different combustion characteristics of the two fuels. The heat content of syngas (approximately 250 British thermal units per cubic foot [Btu/ft<sup>3</sup>], HHV for the oxygen-blown gasification process) is significantly lower than the heat content of natural gas (approximately 1,020 Btu/ft<sup>3</sup>, HHV). This difference in fuel heat content requires a much larger volume of syngas to achieve the same CT heat input compared to natural gas. Another major difference is that the major combustible components of syngas are CO and hydrogen, whereas the major combustible component of natural gas is methane.

The higher flame speed and kinetics of hydrogen combustion prevents the use of current DLN combustor technology for syngas-fired CT. Because the Unit 6 CTs must be capable of firing either syngas or natural gas, DLN combustor technology is also not an available control technology for natural gas.

#### XONON®

The XONON Cool Combustion® technology, developed for CTs by Catalytica Energy Systems, Inc. (CESI), employs a catalyst integral to the CT combustor to reduce the formation of NO<sub>x</sub>. In a conventional CT combustor, fuel and air are oxidized in the presence of a flame to produce the hot exhaust gases required for power generation. The XONON Cool Combustion® technology replaces this conventional combustion process with a two-step approach. First, a portion of the CT fuel is mixed with air and burned in a low-temperature precombustor. The main CT fuel is then added, and oxidation of the total fuel/air mixture stream is completed by means of flameless, catalytic combustion. The catalyst module is located within the CT combustor. NO<sub>x</sub> formation is reduced due to the relatively low oxidation temperatures occurring within the precombustor and the flameless combustor catalyst module. Information provided by CESI indicates that the XONON Cool Combustion® technology is capable of achieving CT NO<sub>x</sub> exhaust concentrations of 2.5 ppmvd at 15-percent oxygen.



Commercial operation of the XONON Cool Combustion® technology is limited to one small (1.5 MW) baseload, natural gas-fired Kawasaki CT operated by the Silicon Valley Power municipal utility located in Santa Clara, California. Performance of the XONON Cool Combustion® technology on larger CTs or on CTs fired with syngas has not been demonstrated to date.

XONON® is not applicable to the Unit 6 CTs because it has not been demonstrated and is not available for this type of unit. In addition, on September 29, 2006, CESI completed the sale of its Xonon Cool Combustion® technology and associated gas turbine assets to Kawasaki Heavy Industries, Ltd., marking the company's exit from the gas turbine emissions control business. Information obtained from the Kawasaki Heavy Industries, Ltd., Web site indicates that the Xonon Cool Combustion® technology (a/k/a catalysis combustion method) is only available for Kawasaki's small 1.5 MW GPC15 series CT/HRSG cogeneration systems.

### **Selective Noncatalytic Reduction**

The SNCR process involves the gas phase reaction, in the absence of a catalyst, of NO<sub>x</sub> in the exhaust gas stream with injected ammonia or urea to yield nitrogen and water vapor. The two commercial applications of SNCR include the Electric Power Research Institute's (EPRI's) NO<sub>x</sub>OUT and Exxon's Thermal DeNO<sub>x</sub> processes. The two processes are similar in that either ammonia (Thermal DeNO<sub>x</sub>) or urea (NO<sub>x</sub>OUT) is injected into a hot exhaust gas stream at a location specifically chosen to achieve the optimum reaction temperature and residence time. Simplified chemical reactions for the Thermal DeNO<sub>x</sub> process are as follows:

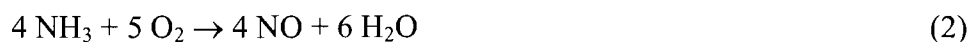
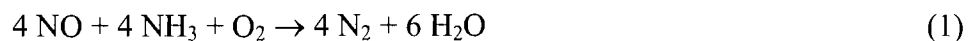

The NO<sub>x</sub>OUT process is similar with the exception that urea is used in place of ammonia. The critical design parameter for both SNCR processes is the reaction temperature. At temperatures below 1,600 degrees Fahrenheit (°F), rates for both reactions decrease allowing unreacted ammonia to exit with the exhaust stream. Temperatures between 1,600

and 2,000°F will favor reaction (1), resulting in a reduction in NO<sub>x</sub> emissions. Reaction (2) will dominate at temperatures above approximately 2,000°F, causing an increase in NO<sub>x</sub> emissions. Due to reaction temperature considerations, the SNCR injection system must be located at a point in the exhaust duct where temperatures are consistently between 1,600 and 2,000°F. The exhaust gas temperatures of the Unit 6 CT/HRSG units are too low for this technology.

### **Nonselective Catalytic Reduction**

The NSCR process uses a platinum/rhodium catalyst to reduce NO<sub>x</sub> to nitrogen and water vapor under fuel-rich (less than 3-percent oxygen) conditions. NSCR technology has been applied to automobiles and stationary reciprocating engines. NSCR has not been applied to IGCCs.

### **Selective Catalytic Reduction**

In contrast to SNCR, SCR reduces NO<sub>x</sub> emissions by reacting ammonia with exhaust gas NO<sub>x</sub> to yield nitrogen and water vapor in the presence of a catalyst. Ammonia is injected upstream of the catalyst bed where the following primary reactions take place:

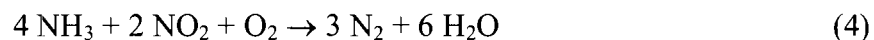
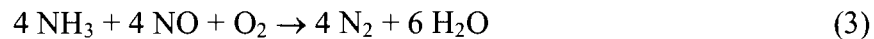

The catalyst serves to lower the activation energy of these reactions, which allows the NO<sub>x</sub> conversions to take place at a lower temperature (i.e., in the range of 600 to 750°F). Typical SCR catalysts include metal oxides (titanium oxide and vanadium), noble metals (combinations of platinum and rhodium), zeolite (alumino-silicates), and ceramics.

Factors affecting SCR performance include space velocity (volume per hour of flue gas divided by the volume of the catalyst bed), ammonia/NO<sub>x</sub> molar ratio, catalyst reactivity, catalyst age, and catalyst bed temperature. Space velocity is a function of catalyst bed depth. Decreasing the space velocity (increasing catalyst bed depth) will improve NO<sub>x</sub> removal efficiency by increasing residence time but will also cause an increase in catalyst bed pressure drop. The reaction of NO<sub>x</sub> with ammonia theoretically requires a 1:1 molar

ratio. Ammonia/NO<sub>x</sub> molar ratios greater than 1:1 are necessary to achieve high-NO<sub>x</sub> removal efficiencies due to imperfect mixing and other reaction limitations. However, ammonia/NO<sub>x</sub> molar ratios are typically maintained at 1:1 or lower to prevent excessive unreacted ammonia (ammonia slip) emissions.

As is the case for SNCR, reaction temperature is critical for proper SCR operation. The optimum temperature range for conventional SCR operation is 600 to 750°F. Below this temperature range, reduction reactions (3) and (4) will not proceed. At temperatures exceeding the optimal range, oxidation of ammonia will take place resulting in an increase in NO<sub>x</sub> emissions.

SCR catalyst is subject to deactivation by a number of mechanisms. Loss of catalyst activity can occur from thermal degradation if the catalyst is exposed to excessive temperatures over a prolonged period of time. Catalyst deactivation can also occur due to chemical poisoning. Principal poisons include arsenic, sulfur, potassium, sodium, and calcium. Due to the potential for chemical poisoning with fuels other than natural gas, application of SCR to CCs has been primarily limited to natural gas-fired units. SCR has not been demonstrated on coal-fired IGCCs.

### **EMx™ ( SCONO<sub>x</sub>™)**

EMx™ (formerly referred to as SCONO<sub>x</sub>™) is a multipollutant reduction catalytic control system offered by EmeraChem. EMx™ is a complex technology that is designed to simultaneously reduce NO<sub>x</sub>, VOC, and CO through a series of oxidation/absorption catalytic reactions.

The EMx™ system employs a single catalyst to simultaneously oxidize CO to CO<sub>2</sub> and NO to NO<sub>2</sub>. NO<sub>2</sub> formed by the oxidation of NO is subsequently absorbed onto the catalyst surface through the use of a potassium carbonate absorber coating. The EMx™ oxidation/absorption cycle reactions are:



CO<sub>2</sub> produced by reactions (5) and (7) is released to the atmosphere as part of the CT/HRSG exhaust stream.

Water vapor and elemental nitrogen are released to the atmosphere as part of the CT/HRSG exhaust stream. Following regeneration, the EMx™ catalyst has a fresh coating of potassium carbonate, allowing the oxidation/absorption cycle to begin again.

Since the regeneration cycle must take place in an oxygen-free environment, the section of catalyst undergoing regeneration is isolated from the exhaust gas stream using a set of louvers.

The EMx™ operates at a temperature range of 300 to 700°F and, therefore, must be installed in the appropriate temperature section of a HRSG. For installations below 450°F, the EMx™ system uses an inert gas generator for the production of hydrogen and CO<sub>2</sub>.

For installations above 450°F, the EMx™ catalyst is regenerated by introducing a small quantity of natural gas with a carrier gas, such as steam, over a steam reforming catalyst and then to the EMx™ catalyst. The reforming catalyst initiates the conversion of methane to hydrogen, and the conversion is completed over the EMx™ catalyst.

Utility materials needed for the operation of the EMx™ control system include ambient air, natural gas, water, steam, and electricity. The primary utility material is natural gas used for regeneration gas production. Steam is used as the carrier/dilution gas for the regeneration gas. Electricity is required to operate the computer control system, control valves, and louver actuators.

Commercial experience to date with the EMx™ control system is limited to several small CC power plants located in California. Representative of these small power plants is a GE LM2500 turbine, owned by Sunlaw Energy Corporation, equipped with water injection to control NO<sub>x</sub> emissions to approximately 25 ppmvd. The low temperature SCONO<sub>x</sub>™ control system (i.e., located downstream of the HRSG at a temperature between 300 and 400°F) was retrofitted to the Sunlaw Energy facility in December 1996 and has achieved a NO<sub>x</sub> exhaust concentration of 3.5 parts per million by volume (ppmv) resulting in an approximate 85-percent NO<sub>x</sub> removal efficiency. This facility is no longer operating due to market factors. A high-temperature application of SCONO<sub>x</sub>™ (i.e., control system located within the HRSG at a temperature between 600 and 700°F) has been in service since June 1999 on a small, 5-MW solar CT located at the Genetics Institute in Massachusetts. Although considered commercially available for large natural gas-fired CTs, there are currently no combined-cycle units larger than 43 MW that have demonstrated successful application of the EMx™ control technology. In addition, there are no syngas-fired combined-cycle units that employ the EMx™ control technology.

### **5.3.1.2 Technical Feasibility and Ranking**

#### **Combustion Temperature Moderation with Water, Steam, Diluent**

Oxygen-blown gasification processes first separate ambient air into its major constituents, oxygen and nitrogen. The oxygen is fed to the gasifier. Virtually all of the nitrogen will be injected into the CT combustors for Unit 6 as it is done at Polk Unit 1 where it serves as a diluent for thermal NO<sub>x</sub> reduction. Accordingly, diluent (i.e., nitrogen) injection is a feasible technology for oxygen-blown IGCC facilities. The extent of its application is limited by nitrogen availability from the air separation plant and, at some point, by combustion stability.

Unit 6 syngas will be saturated with water vapor prior to combustion in the CTs as is practiced at Polk Unit 1. Accordingly, syngas moisturization is a feasible technology for syngas-fired CTs. Direct injection of additional water or steam or more moisturization is not feasible since the resulting heat content of the syngas would be too low to sustain

safe, efficient, and reliable operation of the CT. Water or steam injection is a demonstrated technically feasible technology for CTs fired with natural gas.

### **Dry Low NO<sub>x</sub> Combustor Design**

Due to the combustion characteristics of syngas, DLN combustor technology is not currently available for syngas-fired CTs. The higher flame speed and kinetics of hydrogen combustion prevents the use of current DLN combustor technology for syngas-fired CTs. Because the Unit 6 CTs must be capable of firing both syngas or natural gas, DLN combustor technology is also not an available control technology for this project.

### **XONON™**

The XONON Cool Combustion® technology is not commercially available for a GE 7FB CT. In addition, XONON Cool Combustion® technology has not been demonstrated on large, heavy-duty CTs and on CTs fired with syngas. Accordingly, the XONON Cool Combustion® technology is not considered to be a technically feasible control technology for the Unit 6 CTs.

### **SNCR**

SNCR is not technically feasible because the temperature required for this technology (between 1,600 and 2,000°F) exceeds that found in the Unit 6 CT exhaust gas stream when firing either syngas or natural gas.

### **NSCR**

NSCR was also determined to be technically infeasible because the process must take place in a fuel-rich (less than 3-percent oxygen) environment. Due to high excess air rates, the oxygen content of the Unit 6 CT exhaust is approximately 10 percent.

### **EMx™ (SCONO<sub>x</sub>)**

The EMx™ control technology has not been commercially demonstrated on large CTs or CTs fired with syngas. Nor is it an applicable technology. The Unit 6 CC units have a nominal generation capacity of 400 MW, each. Accordingly, each Unit 6 CC unit is 9.3

times larger than the nominal 43-MW CC unit used at the city of Redding power plant facility located in Redding, California. Technical problems associated with scale-up of the EMx™ technology are unknown. Additional concerns with EMx™ control technology include process complexity (multiple catalytic oxidation/absorption/regeneration systems), reliance on only one supplier, and the relatively brief operating history of the technology.

## **SCR**

Although SCR has not been demonstrated on any operating coal-derived IGCC, and the performance and reliability of SCR applied to coal-derived syngas fired CT/HRSGs are unknown, SCR has been proposed and permitted for some credible IGCC facilities at or below 40 percent NO<sub>x</sub> removal efficiency. Therefore, SCR, with operating constraints, is considered to be technically feasible for Polk Unit 6.

### **5.3.1.3 Evaluation of Control Technologies**

Tampa Electric proposes to install the NO<sub>x</sub> control technologies identified as having the highest control efficiency (i.e., syngas moisture saturation, nitrogen diluent injection and SCR [see Table 5-1]). The economic and energy impacts associated with the installation and operation of this combination of control technologies is considered reasonable. Regarding collateral environmental impacts, use of SCR control technology will result in emissions of ammonia slip. At an ammonia slip concentration of 5.0 ppmvd at 15 percent oxygen, Unit 6 annual ammonia emissions will be 178 tpy. Application of SCR will inevitably result in the need to clean the HRSG more often than without SCR. HRSG cleaning produces a liquid waste which is likely to be hazardous. If SCR is aggressively operated, additional forced outages will likely be required to clean the HRSG. This will produce additional startup/shutdown emissions. Application of SCR will result in additional ammonium sulfate (NH<sub>4</sub>)<sub>2</sub>HSO<sub>4</sub> ammonium sulfate (AS) particulate emissions estimated at 24 tpy. SCR catalyst will require periodic replacement, generating additional hazardous solid waste.

Table 5-1a. Ranking of Available NO<sub>x</sub> Control Technologies  
CT/HRSG—Syngas

Control Technology	Technically Feasible (Yes/No)	Commercially Demonstrated Control Efficiency* (percent)
Combustion Temperature Moderation: Multiple Diluents and SCR	Yes	90-94
Combustion Temperature Moderation: Multiple Diluents	Yes	85-90
Combustion Temperature Moderation: Single Diluent	Yes	75-85
SCR Alone	Yes	30
SNCR	No	Not applicable
NSCR	No	Not applicable
Low-NO <sub>x</sub> burners	No	Not applicable
EMx™	No	Not applicable
XONON®	No	Not applicable

\*Based on an uncontrolled NO<sub>x</sub> exhaust concentration of 150 ppmvd.

Source: ECT, 2007.



Table 5-1b. Ranking of Available NO<sub>x</sub> Control Technologies  
CT/HRSG—Natural Gas

Control Technology	Technically Feasible (Yes/No)	Commercially Demonstrated Control Efficiency* (percent)
Combustion Temperature Moderation: Single Diluent and SCR	Yes	90-95
SCR Alone	Yes	70 – 90
Combustion Temperature Moderation: Single Diluent	Yes	80-85
SNCR	No	Not applicable
NSCR	No	Not applicable
Low-NO <sub>x</sub> burners	No	Not applicable
EM <sub>x</sub> <sup>TM</sup>	No	Not applicable
XONON®	No	Not applicable

\*Based on an uncontrolled NO<sub>x</sub> exhaust concentration of 150 ppmvd.

Source: ECT, 2007.

#### **5.3.1.4 Proposed NO<sub>x</sub> BACT**

Tampa Electric proposes BACT NO<sub>x</sub> emission limits of 99 lb/hr (when firing syngas) and 33 lb/hr (when firing natural gas), on a 30-day rolling average basis for each CT/HRSG unit. For syngas-firing, the proposed BACT NO<sub>x</sub> emission limits are equivalent to 9.0 ppmvd corrected to 15 percent oxygen (ppmvd at 15 percent oxygen), 0.24 lb/MWh (gross), and 0.032 lb/MMBtu (gasifier heat input basis). For natural gas-firing, the proposed BACT NO<sub>x</sub> emission limit is equivalent to 5.0 ppmvd at 15 percent oxygen, and 0.018 lb/MMBtu (CT heat input basis). Tampa Electric requests BACT limits in units of lb/hr since these units are most appropriate in assessing direct environmental impacts (i.e., are used to demonstrate acceptable ambient air quality impacts), and can be easily monitored using CEMS data.

Tables 5-2 and 5-3 provides summaries of IGCC NO<sub>x</sub> BACT determinations for syngas and natural gas firing, respectively.

A combination of diluent nitrogen injection and syngas moisturization has been considered BACT for CTs fired with syngas derived from coal gasification. It is possible that SCR may provide some additional marginally cost-effective NO<sub>x</sub> mitigation, although SCR has never been used in this application. Tampa Electric will install and operate SCRs on the Unit 6 CT/HRSG units in conjunction with diluent nitrogen injection and syngas moisturization in an effort to advance the technology for NO<sub>x</sub> suppression for solid fueled IGCC applications. However, there is considerable uncertainty regarding how to operate an SCR and how it will perform over the long term in this application. The requested permit limits for the effected pollutants, NO<sub>x</sub>, ammonia, PM<sub>10</sub>, and H<sub>2</sub>SO<sub>4</sub> mist, reflect these uncertainties.

We expect that SCR can easily provide significant (greater than 50 percent) NO<sub>x</sub> reduction for short-term operation on coal-derived syngas when the system is in a new and

Table 5-2. NO<sub>x</sub> BACT Summary of IGCC Projects—Syngas Firing

Facility	State	Application/ Permit	Date	Plant Output (MW)	Gasifier Fuel	Gasifier Make	Combustion Turbine	Syngas BACT Limit (lb/MMBtu)*	BACT Control Method
<u>Operating Facilities</u>									
Tampa Electric PPS	FL	Operating since	1996	250	Petcoke/bit	GE (Texaco)	GE 7FA	0.101	DI, M
Wabash River	IN	Operating since	1995	262	Illinois bit	ConocoPhillips	GE 7FA	0.17	SI, M
<u>Facilities with Final Construction Permits</u>									
Taylorville Energy Center (Erora Gp)	IL	Final permit	Jun 2007	677	Illinois bit	GE (Texaco)	GE 7FA (2)	0.024	DI, SCR
Lima Energy IGCC (Global Energy)	OH	Final permit	Mar 2002	530	Petcoke/coal	ConocoPhillips	GE 7FA (2)	0.067	DI
OUC/Southern Stanton B	FL	Final permit	Dec 2006	285	PRB	KBR	GE 7FA (1)	0.08**	DI, SCR
<u>Facilities Having Filed Permit Applications</u>									
Southern Ill Clean Energy Center (Steelhead Energy)	IL	Application	Oct 2004	544	Illinois bit	ConocoPhillips	Not available	0.059	DI
Excelsior Energy - Mesaba	MN	Application	Jun 2006	531	Petcoke/coal	ConocoPhillips	SW SGT6-5000F	0.055	DI, M
American Electric Power Great Bend (AEP)	OH	Application	Sep 2006	629	Eastern bit	GE (Texaco)	GE 7FB (2)	0.057	DI, M
Appalachian Power Mountaineer (AEP)	WV	Application	Sep 2006	600	Eastern bit	GE (Texaco)	GE 7FB (2)	0.057	DI, M
Energy Northwest	WA	Application	Sep 2006	600	Petcoke/coal	ConocoPhillips	SW SGT6-5000F	0.06†	DI, M, SCR
Nueces IGCC Plant (Tondou)	TX	Application	Sep 2006	600	Petcoke/coal	Shell	SW 501 F (2)	0.018	DI, M, SCR
							Maximum	0.170	
							Minimum	0.018	
							Average	0.068	

Note: DI = diluent injection.  
M = syngas moisturization.  
OUC = Orlando Utilities Commission.  
SI = steam injection.

\* Based on heat input to the gasifier.

\*\* This is not a BACT limit. OUC/Southern avoided PSD review for NO<sub>x</sub>.

† Energy Northwest has proposed the use of SCR and Selexol™ as innovative control technology. The proposed innovative control technology limit is significantly lower than BACT. If the innovative control technology limit cannot be met in practice, then a new higher limit, which is at least as stringent as the proposed BACT limit, will be set.

Source: ECT, 2007.

Table 5-3. NO<sub>x</sub> BACT Summary of IGCC Projects—Natural Gas Firing

Facility	State	Application/ Permit	Date	Plant Output (MW)	Gasifier Fuel	Gasifier Make	Combustion Turbine	NG BACT Limit (lb/MMBtu)*	BACT Control Method
<u>Operating Facilities</u>									
Wabash River	IN	Operating since 1995		262	Illinois bit	ConocoPhillips	F Class CT	Not available	SI
<u>Facilities with Final or Draft Construction Permits</u>									
Taylorville Energy Center (Erora Gp)	IL	Final permit	Jun 2007	677	Illinois bit	GE (Texaco)	GE 7FA (2)	0.025	SI, SCR
Lima Energy IGCC (Global Energy)	OH	Final permit	Mar 2002	530	Petcoke/coal	ConocoPhillips	GE 7FA (2)	0.096	SI
OUC/Southern Stanton B	FL	Final permit	Dec 2006	285	PRB	KBR	GE 7FA (1)	0.018**	WI, SI, SCR
<u>Facilities Having Filed Permit Applications</u>									
Southern Ill Clean Energy Ctr (Steelhead Ene	IL	Application	Oct 2004	544	Illinois bit	ConocoPhillips	Not available	0.092	SI
Excelsior Energy - Mesaba	MN	Application	Jun 2006	531	Petcoke/coal	ConocoPhillips	SW SGT6-5000F	0.088	SI
American Electric Power Great Bend (AEP)	OH	Application	Sep 2006	629	Eastern bit	GE (Texaco)	GE 7FB (2)	0.095	SI
Appalachian Power Mountaineer (AEP)	WV	Application	Sep 2006	600	Eastern bit	GE (Texaco)	GE 7FB (2)	0.095	SI
Energy Northwest	WA	Application	Sep 2006	600	Petcoke/coal	ConocoPhillips	SW SGT6-5000F	0.045†	SCR
Nueces IGCC Plant (Tondou)	TX	Application	Sep 2006	600	Petcoke/coal	Shell	SW 501 F (2)	0.021	SCR
							Maximum	0.096	
							Minimum	0.021	
							Average	0.073	

Note: WI = water injection.

\* Based on heat input to the combustion turbine.

\*\* This is not a BACT limit. OUC/Southern avoided PSD review for NO<sub>x</sub>.

† Energy Northwest has proposed the use of SCR and Selexol™ as innovative control technology. The proposed innovative control technology limit is significantly lower than BACT. If the innovative control technology limit cannot be met in practice, then a new higher limit, which is at least as stringent as the proposed BACT limit, will be set.

Source: ECT, 2007.

clean condition. However, since this is a novel application, long-term performance of the SCR is uncertain, as evidenced by the fact that long-term performance guarantees are unavailable. Key areas of uncertainty for this application of SCR are:

- Rate of SCR catalyst deactivation by trace elements in coal derived syngas.
- Deposition rate of AS/ammonium bisulfate  $\text{NH}_4\text{HSO}_4$  ammonium bisulfate salt (ABS) salts on HRSG surfaces.
- An important third unknown that will impact a BACT analysis of SCR for this application is the concentration of  $\text{NO}_x$  entering the SCR.

Considering only operation and maintenance and replacement power costs, SCR could be cost effective (i.e., could be considered BACT when applied in conjunction with syngas moisturization and nitrogen dilution so long as significant  $\text{NO}_x$  removal can be achieved while the above uncertainties are resolved). Specifically, SCR operation must be such that the rate of catalyst deactivation does not require catalyst replacement more often than once per year during the annual planned outage, and the deposition rate of ammonium salts does not necessitate more than one cleaning per year during the annual planned outage. If these conditions cannot be met, the cost of incremental  $\text{NO}_x$  abatement through the application of SCR will likely be considerably greater than \$10,000 per ton. The three operational uncertainties are discussed below.

#### **$\text{NO}_x$ from the Combustion System—Inlet $\text{NO}_x$ to the SCR**

Polk Unit 1 has demonstrated satisfactory operation within the current permit limit of 15 ppmvd  $\text{NO}_x$  adjusted to 15 percent oxygen using diluent nitrogen injection and syngas moisturization. There are three reasons to expect higher  $\text{NO}_x$  from the Polk 6 combustion system:

- The Polk Unit 1 CT is a GE model 7FA, while the Unit 6 CTs will be advanced GE model 7FBs with higher firing temperatures. As explained in Section 5.1.1.1, higher flame temperatures promote more  $\text{NO}_x$  formation, so we expect the 7FB machines to produce more  $\text{NO}_x$ , all other things being equal. It was reported that there were other combustion system changes for the model

7FB to provide better flame stability at low loads which could adversely impact NO<sub>x</sub> production from the 7FB machine.

- Unit 6 will utilize the Selexol™ acid gas removal (AGR) system for deeper sulfur removal than Polk Unit 1, primarily to reduce the rate of formation of AS/ABS deposits on the HRSG surfaces as a result of SCR operation as discussed below. Selexol™ co-adsorbs and removes about twice as much CO<sub>2</sub> from the syngas (native CO<sub>2</sub>) compared to the methyldiethanolamine (MDEA) solvent used for Polk Unit 1. This is an unavoidable side-effect of deeper sulfur removal. CO<sub>2</sub> is a more effective flame temperature moderator than either moisture or diluent nitrogen, so its loss from the fuel gas stream will lead to more NO<sub>x</sub> formation compared to Polk Unit 1.
- GE expects marginally improved gasifier efficiency in Unit 6 compared to Polk Unit 1. This will result in the production of somewhat less native CO<sub>2</sub> in the syngas compared to Polk Unit 1, and consequently more NO<sub>x</sub> production for the reasons cited above.

To offset the above effects, GE is providing slightly more moisturization of the syngas in the Unit 6 design than is employed at Polk Unit 1. GE believes the Unit 6 CTs will be able to operate at the 15 ppmvd NO<sub>x</sub> level, but guarantees have yet to be negotiated. NO<sub>x</sub> production from the Unit 6 CTs will not be precisely known prior to long-term operation of these machines on syngas fuel derived from coal gasification, just as the effects of diluent nitrogen injection, syngas moisturization, and native CO<sub>2</sub> on NO<sub>x</sub> production and combustion stability were not known on the Polk Unit 1 CT before its commercial operation.

### **SCR Catalyst Deactivation**

Trace metals, such as arsenic, nickel, lead, and cadmium, have been detected in syngas produced from solid fuel gasification. These trace metals in the Unit 6 syngas may result in SCR catalyst deactivation. Arsenic is known to deactivate certain types of SCR catalyst. Since there are no full-scale coal-derived IGCC units equipped with SCR, the potential impacts of syngas trace metals on SCR catalyst performance, control efficiency, and

catalyst life are uncertain. The Unit 6 design will include a mercury removal bed which is also expected to remove some of the trace metals that may adversely affect SCR operation. Unit 6 will also include equipment designed to target arsenic. The effectiveness of these systems at removing the trace metals and protecting the SCR catalyst can only be determined through their long term operation.

As the catalyst inevitably becomes deactivated, we can expect that additional ammonia injection (ammonia slip) will be required to achieve the same amount of NO<sub>x</sub> reduction as could be achieved with fresh catalyst. As the deactivation rate becomes known through extended operation, an engineering evaluation will determine when the catalyst should be replaced as well as the appropriate ammonia injection rates, with consideration given to both ammonia and NO<sub>x</sub> emissions. Operating the SCR system with additional ammonia injection is also expected to impact the deposition rate of ammonium salts on the HRSG surfaces as is discussed below. This effect must also be factored into the engineering evaluation.

#### **Ammonium Sulfate/Bisulfate Deposits**

Between 5 percent and 9 percent of the residual sulfur in the syngas fuel is converted to sulfur trioxide (SO<sub>3</sub>) in the CT's combustion system. GE estimates an additional 4 percent will be converted to SO<sub>3</sub> across an SCR catalyst. Excess ammonia is required as a reagent to enable the SCR to convert NO to harmless nitrogen and water. This excess ammonia is referred to as ammonia slip. The excess ammonia reacts with SO<sub>3</sub> to form AS and ABS. Given the extent of AS and ABS deposition which has been reported in boilers and HRSGs, kinetic models, and the large stoichiometric excess of ammonia which is available compared to the amount of SO<sub>3</sub> present, even with very low ammonia slip, it is likely that most, if not all, of the SO<sub>3</sub> is converted to AS or ABS.

As the CT exhaust stream cools in the HRSG downstream of the SCR, these ammonium salt compounds will deposit on heat transfer surfaces. AS is a dry, powdery substance which will lightly adhere to HRSG tube surfaces and may be dislodged to some extent with sootblowing. ABS is a sticky substance which will most likely adhere to the HRSG

tube surfaces and require physical removal, e.g., by washing. Accumulation of these deposits results in:

- Corrosion.
- Plugging of the HRSG flow path leading to high CT exhaust back-pressure.
  - CT efficiency loss.
  - High vibration—mechanical damage.
  - CT trips when back-pressure increases by 5 inches water.
- Steam-cycle efficiency loss due to fouled HRSG heat transfer surfaces.

The following HRSG modifications may be able to mitigate some of the adverse impacts of the deposits. The effectiveness of these modifications can only be determined during sustained commercial operation.

- Additional tube surface area to compensate for some of the fouling
- Wider tube spacing to reduce CT back-pressure.
- Bracing to control tube vibration.
- Soot-blowing to dislodge some of the AS deposits.
- Tube and tube bank arrangement to facilitate washing/cleaning.
- Special corrosion-resistant materials of construction.

The source of the  $\text{SO}_3$ , hence the source of the deposits, is residual sulfur in the syngas fuel. Unit 6 will utilize COS hydrolysis and the Selexol™ AGR system and the plant will be designed to operate 200 psig higher than otherwise necessary to satisfy the Selexol™ technology operating pressure requirement. These expensive steps were taken in order to reduce the sulfur content of the syngas to a level theoretically projected to provide for acceptable SCR operation. Although this combination of technologies will result in a very low syngas sulfur content, the potential for HRSG fouling due to the accumulation of AS and ABS salt deposits still exists. Research by GE and EPRI, as well as EPA and DOE technical reports, indicates that even low concentrations of sulfur in the CT exhaust are sufficient to result in sulfate salt formation and excessive fouling of HRSG heat transfer surfaces. The use of COS hydrolysis and Selexol™ technology reduces, but does not eliminate, the potential for HRSG corrosion and fouling.



As reported in Section 5.4.1.3, the application of Selexol™ is too expensive to be considered BACT for SO<sub>2</sub> emissions control, but it was deemed necessary to provide the possibility of economically practical SCR operation. The use of Rectisol® for deeper sulfur removal would be even more expensive. The use of Selexol™ (and to a greater extent Rectisol®) is to some extent self-defeating if NO<sub>x</sub> abatement is the objective, because each removes increasingly more of the native CO<sub>2</sub> from the syngas, leading to more NO<sub>x</sub> production in the CT combustion system.

Another potential variable affecting the rate of ammonium salt formation and deposition is ammonia slip. Theoretically, higher ammonia slip should favor the production of the powdery AS which might be controllable with sootblowing. However, experience with coal-fired boilers indicates that the fouling rate quadruples as ammonia slip doubles from 2 to 4 ppmv. Conditions are so different in coal-fired boilers that the relevance of this information is questionable. We can expect that increasing ammonia slip will lower NO<sub>x</sub> emissions at the expense of increased ammonia emissions. Adjusting ammonia slip can also be expected to impact plugging rate and PM emissions (AS dust). However, the exact nature of the relationships will only be determined through sustained commercial operation.

### **Most Relevant Experience, Recent Permits and BACT Determinations**

#### **Liquid Fuel Gasification**

There are three IGCC plants worldwide equipped with SCRs firing syngas derived from liquid fuel gasification. They are located at the api Maritima Refinery (Falconara, Italy), the ISAB Energy Refinery (Syracusa, Sardinia, Italy), and the NPRC refinery, (Negishi, Yokohama, Japan).

The Maritima Refinery IGCC utilizes COS hydrolysis and Selexol™ for sulfur removal. The clean syngas sulfur content is in the same range as that planned for Unit 6. The Maritima Refinery operates their IGCC SCR at 30 percent NO<sub>x</sub> conversion with low ammonia slip. HRSG plugging has been problematic, and vibration is a significant issue, but the

refinery is able to sustain operation with only one HRSG cleaning during their annual planned outage. The Maritima Refinery has had some success in mitigating deposit formation with soot-blowing.

ISAB utilizes COS hydrolysis and MDEA for sulfur removal. ISAB also achieves about the same level of residual sulfur in the syngas as is planned for Unit 6. The less expensive chemical solvent, MDEA, is more effective in removing sulfur from syngas derived from oil gasification due to its lower native CO<sub>2</sub> content. ISAB was originally only required to operate their SCR when firing their back-up fuel, but are now required to also operate it when firing syngas. SCR conversion and ammonia slip have not been reported. Likewise, ISAB experiences with HRSG plugging have not been publicly reported, but secondary sources report that they had required two HRSG cleanings per year.

NPRC utilizes COS hydrolysis and the Shell ADIP AGR process. The ADIP process is reported to rely on a mixture of solvents. NPRC has not reported the syngas residual sulfur content, ammonia slip, or SCR removal efficiency. NPRC did report very low NO<sub>x</sub> emissions during early operation (<2.6 ppmvd at 16 percent oxygen). NPRC has not reported their long term operational experiences regarding HRSG deposits, or if the facility has been able to sustain this low level of NO<sub>x</sub> emissions.

### **Solid Fuel Gasification**

The only permitted solid-fueled IGCC facility in the United States with SCR as BACT is the Christian County Generation, LLC Taylorville Energy Center (Illinois). Other solid-fueled IGCC projects in the United States that have proposed the use of SCR are the Energy Northwest Pacific Mountain Energy Center (Washington) and OUC Stanton Station (Florida). In Europe, NUON has recently received a permit for their NUON Magnum IGCC plant (Eemshavenm Netherlands)

The PSD air permit for the Christian County Generation, LLC Taylorville Energy Center was recently issued by the Illinois EPA on June 5, 2007. The Taylorville Energy Center IGCC project is comparable in scope and size to Unit 6 (i.e., both projects are 2 x 1 com-

bined-cycle units that will generate approximately 800 MW, gross). The applicant originally proposed a NO<sub>x</sub> BACT emission limit (i.e., 0.058 lb/MMBtu, CT heat input basis) that did not include SCR, but subsequently agreed to install SCR achieving an emission rate of 0.034 lb/MMBtu, CT heat input basis. These NO<sub>x</sub> emission rates equate to a SCR control efficiency of 40 percent. In contrast to Tampa Electric, an investor owned utility (IOU), Christian County Generation, LLC is an independent power producer. Christian County Generation, LLC is reportedly still seeking funding for the Taylorville Energy Center project. Accordingly, it is uncertain whether the Taylorville Energy Center project will actually be constructed.

Another United States IGCC project that has proposed the use of SCR is the Energy Northwest Pacific Mountain Energy Center planned at a site in Washington. However, the Energy Northwest application clearly states that SCR is not considered BACT since SCR is not a demonstrated technology and available for IGCC plants. Energy Northwest concluded that SCR when applied to syngas-fired CTs is an “innovative control technology” and “an enhanced level of emission control that is more stringent than BACT.”

In Europe, NUON received a permit for their Magnum IGCC plant May, 2007, incorporating SCR. The permitted basis for their SCR is 37.5 percent NO<sub>x</sub> removal.

### **Pulverized Coal Plants**

The NO<sub>x</sub> emission limit proposed for Unit 6, equivalent to 0.032 lb/MMBtu, is well below the rates recently proposed for state-of-the-art PC projects. For example, the Taylor Energy Center project planned for a site in Taylor County, Florida proposed a NO<sub>x</sub> BACT limit of 0.05 lb/MMBtu, roughly 1.5 times higher than the limit proposed for Unit 6. Recent NO<sub>x</sub> BACT determinations are shown in Table 5-4.

NO<sub>x</sub> BACT proposed for each CT/HRSG unit is summarized as follows:

#### **Syngas Firing**

- Emission Limit—99 lb/hr.

Table 5-4. Summary of Coal-Fired Power Plant NO<sub>x</sub> BACT Determinations

Plant	State	Permit Date	Unit Number	Boiler Type	Generation Capacity (MW)	Comments	BACT Limit NO <sub>x</sub> (lb/MMBtu)
Springerville Generating Station (Tucson Electric Power Co)	AZ	Apr 2002	3, 4	PC	800	LNB/SCR	0.170
Plum Point Energy Station (Plum Point Energy Associates, LLC)	AR	8/20/03	1	PC	800	SCR	0.090
Comanche Plant Unit 3 (Public Service Company of CO)	CO	Jul 2005	3	PC	750	SCR	0.080
Xcel Energy	CO	Jul 2005		PC	750	SCR; not subject to PSD review 30-day average	0.080
Indiantown Cogeneration Plant (Indiantown Cogeneration, LP)	FL	1995	1	PC	330	SCR	0.170
Seminole Electric Unit 3	FL	Draft	3	SCPC	750	SCR; not subject to PSD review	
Stanton Energy Center (MUA/OUC/FMPA)	FL	1996	2	PC	468	SCR	0.170
Longleaf Energy Station (LS Power)	GA	Draft	1, 2	PC	600	SCR	0.070
Holcomb Generating Station (Sand Sage Power, LLC)	KS	4/5/04	2	PC	660	LNB/OFA/SCR	0.070
Louisville Gas & Electric	KY	Jan 2006		SCPC	750	SCR; not subject to PSD review	0.110
Thoroughbred Generating Station (Thoroughbred Generating Co, LLC)	KY	May 2006	1,2	PC	1,500	SCR	0.070
MidAmerican Energy Center Council Bluffs (MidAmerican Energy)	IA	6/17/03	4	SCPC	750	SCR	0.070
Baldwin Expansion (Dynergy)	IL	Pending	1,2	PC	750		0.080
Dellman Unit 4 (City Water Light & Power - Springfield, IL) (Not subject to SO <sub>2</sub> or NO <sub>x</sub> BACT)	IL	Draft (Feb 2006)	4	PC	250	Not subject to PSD review	0.100
Prairie State (Prairie State Generating Co, LLC)	IL	Apr 2005	1,2	PC	1,500	SCR	0.070
Prairie Energy Power Plant (Corn Belt Energy Corporation)	IL	12/17/02	1	PC	91	SCR 30-day rolling average	0.120
Franklin Energy Coal Project (Illinois Energy Group)	IL	Pending	1,2	PC	680		0.080
NRG Energy (Big Cajun II) (Louisiana Generating, LLC)	LA	Aug 2005	2	SCPC	575	LNB/SCR 30-day rolling average	0.070
KCP&L Latan Generating	MO	Jan 2006	1	PC	850	SCR 30-day average	0.080
Weston Bend Generating Station (Great Plains Power Company)	MO	Nov 2001	1	PC	820	30-day average	0.080
Southwest Power Station (City Utilities of Springfield)	MO	12/15/04	2	PC	275	SCR	0.080
Roundup Power Project (Bull Mountain Development Co)	MT	7/21/03	1, 2	PC	780	SCR	0.070 0.100
Rocky Mountain Power (Rocky Mountain Power, Inc.)	MT	6/11/02	1	PC	113	30-day average	0.090
Montana Dakota Utilities	ND	Jun 2005		PC	220		0.09

Table 5-4. Summary of Coal-Fired Power Plant NO<sub>x</sub> BACT Determinations

Plant	State	Permit Date	Unit Number	Boiler Type	Generation Capacity (MW)	Comments	BACT Limit NO <sub>x</sub> (lb/MMBtu)	
Whelan Energy Center (Hastings Utilities)	NE	Mar 2004	1	PC	220	SCR 30-day average	0.08	
Nebraska City Unit 2 (Omaha Public Power District)	NE	Mar 2005	2		660	SCR 30-day average	0.07	
Newmont TS Power Plant (Newmont NV Energy Investment, LLC)	NV	May 2005		PC	200	LNB/SCR	0.067	
Desert Rock Energy Facility (Steag Power, LLC)	NM	Pending	1, 2	PC	750	SCR 24-hour average	0.06	
Cottonwood Energy Center (Chaco Valley Energy, LLC)	NM	Pending	1	PC	495		0.06	
Mustang Generating Station (Chaco Valley Energy, LLC)	NM	Pending	1	PC	330		0.06	
Santee Cooper Cross (Not subject to SO <sub>2</sub> or NO <sub>x</sub> BACT)	SC	2/5/04	3,4	PC	660	SCR	0.08	
Calaveras Plant Spruce Unit 2 (Not subject to SO <sub>2</sub> or NO <sub>x</sub> BACT)	TX	12/05	2	PC	750		0.069	
City Public Service	TX	Sep 2005		PC	750	SCR	0.069	
Sandy Creek Energy (LS Power)	TX	Pending	1	PC	500	30-day average	0.07	
Intermountain Power (Intermountain Power Service Corp)	UT	10/15/04	3	PC	950	SCR	0.07	
Weston Unit 4 (Wisconsin Public Service Company)	WI	Oct 2004	1	PC	500		0.07	
Elm Road Generating Station (We Energy - formerly WEPCO)	WI	1/14/04	1,2	SCPC	1,230	SCR	0.07	
Public Service Corp Wausau	WI	Oct 2004		SCPC	500	LNB/SCR	0.06	
Longview Power (Longview Power, LLC)	WV	3/2/04	1	PC	600	SCR	0.08	
WYGEN II (Black Hills Corporation)	WY	Sep 2002	1	PC	500	30-day average	0.07	
Black Hills (Black Hills Corporation)	WY	Jun 1999	1	PC	80	30-day average	0.22	
Two Elk (Two Elk Generation Partners, L.P.)	WY	May 2003	1	PC	250		0.09	
							Minimum	0.060
							Maximum	0.220
							Average	0.088
							Median	0.080

Source: ECT, 2007.

- Averaging Period—30-day rolling average.
- Compliance Method—Continuous emissions monitoring in accordance with 40 CFR 75.

#### **Natural Gas Firing**

- Emission Limit—33 lb/hr.
- Averaging Period—30-day rolling average.
- Compliance Method—Continuous emissions monitoring in accordance with 40 CFR 75.

### **5.3.2 AUXILIARY BOILER**

Unit 6 will be equipped with a 300 MMBtu/hr (HHV) auxiliary boiler fired with pipeline-quality natural gas. Total annual fuel use in the auxiliary boiler will be limited to 262,752 million British thermal units per year (MMBtu/yr). This annual fuel heat input is equivalent to an auxiliary boiler capacity factor of 10 percent (i.e., operating no more than 876 hr/yr at full load).

#### **5.3.2.1 Available NO<sub>x</sub> Control Technologies**

The NO<sub>x</sub> control technologies previously described for the CTs are also applicable to the auxiliary boiler.

In addition, overfire air (OFA), natural gas reburn (NGR), and flue gas recirculation (FGR) are potentially applicable NO<sub>x</sub> control technologies. Each of these combustion control technologies are discussed below.

#### **Over-fire Air**

OFA is a form of staged combustion. In the primary combustion zone, combustion air is diverted from the burners creating a fuel rich zone in the lower section of the boiler. This oxygen-deficient zone decreases the conversion of FBN to NO<sub>x</sub>. Additional combustion air is injected above the primary combustion zone to complete the combustion process. The OFA is injected using a wind-box equipped with ports and/or nozzles. The resulting reduction in temperature decreases the production of thermal NO<sub>x</sub>. OFA is typically used

in conjunction with low-NO<sub>x</sub> burners to provide the air required to complete the combustion process and limit the formation of CO and VOC.

### **Natural Gas Reburn**

NGR is a process which diverts some of the heat input to the main boiler to an area above the main boiler burners. This diversion creates a secondary reburn combustion zone. Natural gas is injected in the reburn zone producing a slightly fuel rich section. OFA is then added above the reburn zone to complete the combustion process. As NO<sub>x</sub> formed in the main combustion zone is reduced by hydrocarbon fragments (free radicals), due to the combustion of natural gas in the reburn zone, it is converted to molecular nitrogen. NGR has been demonstrated to reduce NO<sub>x</sub> emissions by approximately 40 to 70 percent.

### **Flue Gas Recirculation**

FGR recirculates boiler flue gas from the boiler outlet to the furnace where is re-introduced into the combustion process. Fuel/air mixing in the combustion region is increased by the recirculated flue gas during the early stages of combustion. This increased mixing and reduction in peak flame temperatures results in lower thermal NO<sub>x</sub> formation. The amount of NO<sub>x</sub> reduction is dependent upon the burner and furnace design. FGR has been demonstrated as a NO<sub>x</sub> reduction technology on natural gas and oil-fired boilers.

#### **5.3.2.2 Technical Feasibility and Ranking**

All of the combustion modification control technologies noted above and previously described in Section 5.3.1.1 for the CTs are feasible for the auxiliary boiler with the exception of XONON®. Of the available postcombustion NO<sub>x</sub> control technologies, FGR, NGR, and SCR are considered technically feasible. NSCR, SNCR, and the EMx™ technologies each have constraints on exhaust gas temperatures and/or oxygen contents that would prevent these technologies from being applied to the auxiliary boiler.

#### **5.3.2.3 Proposed NO<sub>x</sub> BACT**

The auxiliary boiler will operate with a capacity factor of no more than 10 percent, which is equivalent to 876 hr/yr operation at design capacity. Installation of FGR, NGR, or SCR

would result in excessive costs on a dollar per ton of NO<sub>x</sub> removed basis due to the limited annual operating hours of the auxiliary boiler.

Use of low-NO<sub>x</sub> burner control technology achieving 0.036 lb/MMBtu, together with a constraint on annual operations, is proposed as NO<sub>x</sub> BACT for the auxiliary boiler. The proposed emission limit is consistent with the lowest auxiliary boiler NO<sub>x</sub> BACT limits shown in Table 5-5, which is based on information from the RBLC database. NO<sub>x</sub> BACT proposed for the Unit 6 auxiliary boiler is summarized as follows:

- Emission Limit—10.8 lb/hr.
- Averaging Period—Duration of stack test.
- Compliance Method—Stack test using EPA Reference Methods.
- Annual Heat Input—262,752 MMBtu/yr.
- Averaging Period—Calendar year.
- Compliance Method—Fuel consumption monitoring.

### 5.3.3 EMERGENCY DIESEL ENGINES

The Polk Unit 6 Project will include a diesel engine-driven emergency generator rated at 1,640 kW (2,200 hp), and two diesel engine-driven firewater pumps each rated at 420 hp. Excluding emergencies, each diesel engine will operate no more than 100 hr/yr for routine testing and maintenance purposes. Total estimated NO<sub>x</sub> emissions for the three diesel engines is approximately 2 tpy.

The emergency diesel engines will be subject to the applicable emission standards of NSPS Subpart IIII for new nonroad CI engines. Subpart IIII limits the combination of NO<sub>x</sub> and NMHC emissions to 6.4 g/kW-hr for emergency generators purchased in 2007 or later. For firewater pumps, Subpart IIII also limits the combination of NO<sub>x</sub> and NMHC emissions, but the emission limits (Tier II or III) are dependent upon the model year in which the pump was manufactured. Emergency diesel engines purchased for the Unit 6 project will comply with the applicable emission standards of NSPS Subpart IIII.



Table 5-5. Recent BACT Determinations for Natural Gas-Fired Auxiliary Boilers

RBLC ID	Company Name	Permit Date	Heat Input (MMBtu/hr)	NO <sub>x</sub> (lb/MMBtu)	CO (lb/MMBtu)	PM <sub>10</sub> (lb/MMBtu)	SO <sub>2</sub> (lb/MMBtu)
OK-0115	Energetix	12/12/06	Not applicable	0.036	—	—	—
OH-0307	Biomass Energy	04/04/06	247	—	0.11	0.007	—
NV-0035	Sierra Pacific Power Co.	08/16/05	159	0.037	0.036	0.004	—
MD-0032	Mirant Mid-Atlantic, LLC	11/05/04	60	0.05	0.05	0.01	0.01
OH-0269	Biomass Energy	01/05/04	247	0.06	0.11	0.007	0.6
TX-0469	Texas Petrochemicals LP	10/08/03	332	0.036	0.077	0.008	0.015
IA-0067	Mid-American Energy Co.	06/17/03	60	Not applicable	0.15	0.0076	0.0006
na	Taylorville Energy Center	06/05/07	279	0.036	0.037	0.007	0.006
		Maximum	332	0.06	0.15	0.01	0.6
		Minimum	60	0.036	0.036	0.004	0.0006
		Average	198	0.043	0.081	0.007	0.126

Source: ECT, 2007.

5-34

### **5.3.3.1 Proposed NO<sub>x</sub> BACT**

Compliance with the stringent NSPS Subpart IIII emission standards and limited annual operating hours is proposed as NO<sub>x</sub> BACT for the Unit 6 emergency generator and fire-water pump diesel engines. The NO<sub>x</sub> BACT proposed for the Unit 6 emergency diesel engines is summarized as follows:

- Emission Limit—Applicable standards of NSPS Subpart IIII.
- Averaging Period—Per NSPS Subpart IIII.
- Compliance Method—Engine manufacturer certification in accordance with NSPS Subpart IIII.
- Annual Operating Hours—100 hr/yr/engine (excluding emergencies).
- Averaging Period—Calendar year.
- Compliance Method—Monitoring of operating hours using engine run-time meters.

## **5.4 BACT ANALYSIS FOR SO<sub>2</sub> AND H<sub>2</sub>SO<sub>4</sub> MIST**

### **5.4.1 CT/HRSG**

#### **5.4.1.1 Available SO<sub>2</sub> and H<sub>2</sub>SO<sub>4</sub> Mist Control Technologies**

Fuel treatment technologies are typically applied to gaseous and liquid fuels to reduce their sulfur contents prior to delivery to end fuel users. For wellhead natural gas containing sulfur compounds, a variety of technologies are available to remove these sulfur compounds to acceptable levels. Desulfurization of natural gas is performed by the fuel supplier prior to distribution by pipeline.

Similar to natural gas, desulfurization of syngas is conducted via the design of the gasification process prior to its use as a fuel. Available syngas cleanup sulfur removal technologies include chemical and physical absorption AGR processes. The sulfur removal efficiencies of these AGR processes are improved if COS hydrolysis catalyst is included as part of the syngas treatment system since most AGR processes are not cost-effective in removing COS. COS hydrolysis catalyst will convert COS to H<sub>2</sub>S which is effectively removed by the AGR processes.

### **Chemical Absorption AGR**

Chemical absorption utilizes an amine solvent such as MDEA to chemical react with H<sub>2</sub>S and CO<sub>2</sub> contained in the untreated syngas. The reacted amine solvent is then sent to a stripper where steam heat is used to separate H<sub>2</sub>S and regenerate the MDEA for recycle to the syngas cleanup process. Chemical absorption using amine solvents is widely used in the petroleum and chemical industries and is the syngas sulfur treatment technology employed at the two United States operating IGCC facilities; i.e., Polk Unit 1 and Wabash River. The syngas H<sub>2</sub>S removal efficiency for MDEA chemical absorption technology is approximately 99.5 percent.

### **Physical Absorption AGR**

Physical absorption processes use solvents that dissolve syngas acid gases under elevated pressures. Examples of physical solvents include Selexol™ (dimethylether or polyethylene glycol) and Rectisol™ (cold methanol). Since the solubility of an acid gas is proportional to its partial pressure, the efficiency of physical absorption processes in removing acid gases increases with higher absorption column operating pressures. For both solvents, untreated syngas flows to an absorption tower where the syngas acid gases (e.g., H<sub>2</sub>S) are absorbed in the solvent under pressure. The acid gas-rich solvent is then reclaimed through pressure reduction, reheating, and stripping. The reclaimed solvent is recycled to the absorption tower and stripped acid gases sent to the sulfur recovery unit.

The physical absorption AGR processes provide incrementally higher AGR efficiencies at greater costs compared to MDEA chemical absorption. Approximate syngas sulfur removal efficiencies are 99.8 percent and 99.9 percent for the Selexol™ and Rectisol™ AGR technologies, respectively.

Technologies employed to control postcombustion SO<sub>2</sub> and H<sub>2</sub>SO<sub>4</sub> mist emissions consist of add-on controls (i.e., FGD systems). FGD systems remove SO<sub>2</sub> from exhaust streams by using an alkaline reagent to form sulfite and sulfate salts. The reaction of SO<sub>2</sub> with the alkaline chemical can be performed using either a wet- or dry-contact system. FGD wet

scrubbers typically employ sodium, calcium, or dual-alkali reagents using packed or spray towers. Wet FGD systems will generate wastewater and wet sludge streams requiring treatment and disposal. In a dry FGD system, an alkaline slurry is injected into the combustion process exhaust stream. The liquid sulfite/sulfate salts that form from the reaction of the alkaline slurry with SO<sub>2</sub> are dried by heat contained in the exhaust stream and subsequently removed by downstream PM control equipment.

#### **5.4.1.2 Technical Feasibility and Ranking**

There have been no applications of FGD technology to CTs fired with syngas or natural gas because these fuels contain very low sulfur contents. The sulfur content of syngas, the primary fuel source for the CTs is much lower than the fuels (e.g., coal) employed in boilers using FGD systems. In addition, CTs operate with a significant amount of excess air that generates high exhaust gas flow rates. Because FGD SO<sub>2</sub> removal efficiency decreases with decreasing inlet SO<sub>2</sub> concentration, application of an FGD system to a CT exhaust stream will result in unreasonably low SO<sub>2</sub> removal efficiencies. Due to low SO<sub>2</sub> exhaust stream concentrations, FGD technology is not considered to be technically feasible for CTs because removal efficiencies would be unreasonably low. Similarly, use of mist eliminators to control H<sub>2</sub>SO<sub>4</sub> mist emissions is not technically feasible due to the low H<sub>2</sub>SO<sub>4</sub> mist exhaust concentrations. For example, the Unit 6 CT/HRSG will have an H<sub>2</sub>SO<sub>4</sub> mist exhaust concentration of approximately 0.00001 gr/scf during syngas-firing.

#### **5.4.1.3 Evaluation of Control Technologies**

Based on economic analyses for two similar IGCC projects, the Pacific Northwest Pacific Mountain Energy Center and the Christian County Generation, LLC Taylorville Energy Center, both physical absorption AGR technologies (i.e., Selexol™ and Rectisol™), will have an incremental cost-effectiveness greater than \$20,000 per ton of SO<sub>2</sub> controlled compared to MDEA chemical absorption. The physical absorption AGR technologies therefore do not represent BACT due to adverse economic impacts. Accordingly, MDEA chemical absorption achieving a syngas sulfur content, prior to dilution, of 50 ppm is considered to represent BACT for coal-derived IGCC projects. For Unit 6, this syngas sulfur content is equivalent to SO<sub>2</sub> emission rates per CT/HRSG unit of 65 lb/hr,

4.3 ppmvd at 15 percent oxygen, 0.16 lb/MWh (gross), and 0.021 lb/MMBtu (gasifier heat input basis).

As indicated in the evaluation of NO<sub>x</sub> BACT, Tampa Electric plans to install an SCR control system to reduce NO<sub>x</sub> emissions. Although not considered BACT, Tampa Electric also plans to install a Selexol™ physical absorption AGR system to reduce the potential for sulfate deposition in the HRSGs when firing syngas.

#### **5.4.1.4 Proposed SO<sub>2</sub> and H<sub>2</sub>SO<sub>4</sub> Mist BACT**

Tampa Electric proposes a BACT SO<sub>2</sub> emission limit of 52 lb/hr (when firing syngas), on a 30-day rolling average basis, and use of pipeline quality natural gas containing no more than 2.0 gr S/100 scf (when firing natural gas) for each CT/HRSG unit. For syngas-firing, the proposed BACT SO<sub>2</sub> emission limit is equivalent to 3.4 ppmvd at 15 percent oxygen, 0.13 lb/MWh (gross), and 0.017 lb/MMBtu (gasifier heat input basis). As previously stated, Tampa Electric requests BACT limits in units of lb/hr since these units are most appropriate in assessing direct environmental impacts (i.e., are used to demonstrate acceptable ambient air quality impacts), and can be easily monitored using CEMS data.

Tampa Electric proposes a BACT H<sub>2</sub>SO<sub>4</sub> mist emission limit of 12.8 lb/hr (when firing syngas), on a 3-hour average basis, and use of pipeline quality natural gas containing no more than 2.0 gr S/100 scf (when firing natural gas) for each CT/HRSG unit. For syngas-firing, the proposed BACT H<sub>2</sub>SO<sub>4</sub> emission limit is equivalent to 0.031 lb/MWh (gross), and 0.0040 lb/MMBtu (gasifier heat input basis).

The proposed Unit 6 SO<sub>2</sub> and H<sub>2</sub>SO<sub>4</sub> mist emission limits are considered to represent BACT for the following reasons:

- Use of Selexol™ physical absorption AGR technology will provide better performance (i.e., lower syngas sulfur content), compared to MDEA chemical absorption.
- The proposed syngas SO<sub>2</sub> emission limit is based on the treated syngas containing up to 40 ppm H<sub>2</sub>S and COS. This sulfur concentration reflects the IGCC vendor

(i.e., GE) syngas sulfur content estimate of 20 ppm for a new and clean system, with appropriate margins. These margins, based on Tampa Electric's extensive experience in operating Polk Unit 1 IGCC, include reduced performance of the COS catalyst and Selexol™ solvent due to aging and high temperature operating conditions. COS catalyst performance is also reduced during the first 2 days of each gasifier run.

- A long-term guarantee of syngas sulfur content is not available from the IGCC vendor (GE). Tampa Electric cannot accept a BACT emission limit for SO<sub>2</sub> that results in periodic non-compliance (e.g., higher syngas sulfur contents due to operational upsets). Accordingly, a margin is needed to ensure that Unit 6 will be able to meet the SO<sub>2</sub> BACT emission limit, not only when the system is new and clean, but also throughout the life of the facility.

Recent SO<sub>2</sub> BACT determinations for syngas and natural gas fired CTs are based on the use of clean fuels. Tables 5-6 and 5-7 provide recent SO<sub>2</sub> BACT determinations for CTs fired with syngas and natural gas, respectively. Tables 5-8 and 5-9 provide recent H<sub>2</sub>SO<sub>4</sub> mist BACT determinations for CTs fired with syngas and natural gas, respectively. Tables 5-10 and 5-11 provide recent SO<sub>2</sub> and H<sub>2</sub>SO<sub>4</sub> mist BACT determinations for bituminous pulverized coal fired boilers.

The SO<sub>2</sub> and H<sub>2</sub>SO<sub>4</sub> mist BACT emission limits proposed for each Unit 6 CT/HRSG unit are summarized as follows:

**Syngas Firing (SO<sub>2</sub>)**

- Emission Limit—52 lb/hr.
- Averaging Period—30-day rolling average.
- Compliance Method—Continuous emissions monitoring in accordance with 40 CFR 75.

Table 5-6. SO<sub>2</sub> BACT Summary of IGCC Projects—Syngas Firing

Facility	State	Application/ Permit	Date	Plant Output (MW)	Gasifier Fuel	Gasifier Make	Combustion Turbine	Syngas BACT Limit (lb/MMBtu)*	BACT Control Method
<b>Operating Facilities</b>									
Tampa Electric PPS	FL	Operating since 1996		250	Petcoke/bit	GE (Texaco)	GE 7FA	0.16	MDEA
Wabash River	IN	Operating since 1995		262	Illinois bit	ConocoPhillips	F Class CT	0.126	MDEA
<b>Facilities with Final Permits</b>									
OUC/Southern Stanton Unit B	FL	Final permit	Dec 2006	285	PRB	KBR	GE 7FA (1)	0.0148	CrystaSulf
Taylorville Energy Center (Erora Gp)	IL	Final permit	Jun 2007	677	Illinois bit	GE (Texaco)	GE 7FA (2)	0.012	Selexol™
Lima Energy IGCC (Global Energy)	OH	Final permit	Mar 2002	530	Petcoke/coal	ConocoPhillips	GE 7FA (2)	0.035	MDEA
<b>Facilities Having Filed Permit Applications</b>									
Southern Ill Clean Energy Ctr (Steelhead Energy)	IL	Application	Oct 2004	544	Illinois bit	ConocoPhillips	Not available	0.033	MDEA
Excelsior Energy - Mesaba	MN	Application	Jun 2006	531	Petcoke/coal	ConocoPhillips	SW SGT6-5000F	0.027	MDEA
American Electric Power Great Bend (AEP)	OH	Application	Sep 2006	629	Eastern bit	GE (Texaco)	GE 7FB (2)	0.017	Selexol™
Appalachian Power Mountaineer (AEP)	WV	Application	Sep 2006	600	Eastern bit	GE (Texaco)	GE 7FB (2)	0.017	Selexol™
Energy Northwest	WA	Application	Sep 2006	600	Petcoke/coal	ConocoPhillips	SW SGT6-5000F	0.08**	Selexol™
Nueces IGCC Plant (Tongu)	TX	Application	Sep 2006	600	Petcoke/coal	Shell	SW 501 F (2)	0.017	Not available
							Maximum	0.160	
							Minimum	0.012	
							Average	0.049	

\* Based on heat input to the gasifier.

\*\* Energy Northwest has proposed the use of SCR and Selexol™ as innovative control technology. The proposed innovative control technology limit is significantly lower than BACT. If the innovative control technology limit cannot be met in practice, then a new higher limit, which is at least as stringent as the proposed BACT limit, will be set.

Source: ECT, 2007.

Table 5-7. SO<sub>2</sub> BACT Summary of IGCC Projects—Natural Gas Firing

Facility	State	Application/ Permit	Date	Plant Output (MW)	Gasifier Fuel	Gasifier Make	Combustion Turbine	NG BACT Limit (lb/MMBtu)*	BACT Control Method
<u>Operating Facilities</u>									
Wabash River	IN	Operating since 1995		262	Illinois bit	ConocoPhillips	F Class CT	Not applicable	Clean fuel
<u>Facilities with Final or Draft Construction Permits</u>									
OUC/Southern Stanton Unit B	FL	Final permit	Dec 2006	285	PRB	KBR	GE 7FA (1)	Not available	Clean fuel
Taylorville Energy Center (Erora Gp)	IL	Final permit	Jun 2007	677	Illinois bit	GE (Texaco)	GE 7FA (2)	0.0010	Clean fuel
Lima Energy IGCC (Global Energy)	OH	Final permit	Mar 2002	530	Petcoke/coal	ConocoPhillips	GE 7FA (2)	0.0210	Clean fuel
<u>Facilities Having Filed Permit Applications</u>									
Southern Ill Clean Energy Ctr (Steelhead Ene	IL	Application	Oct 2004	544	Illinois bit	ConocoPhillips	Not available	0.0006	Clean fuel
Excelsior Energy - Mesaba	MN	Application	Jun 2006	531	Petcoke/coal	ConocoPhillips	SW SGT6-5000F	0.0027	Clean fuel
American Electric Power Great Bend (AEP)	OH	Application	Sep 2006	629	Eastern bit	GE (Texaco)	GE 7FB (2)	0.0005	Clean fuel
Appalachian Power Mountaineer (AEP)	WV	Application	Sep 2006	600	Eastern bit	GE (Texaco)	GE 7FB (2)	0.0005	Clean fuel
Energy Northwest	WA	Application	Sep 2006	600	Petcoke/coal	ConocoPhillips	SW SGT6-5000F	0.0028	Clean fuel
Nueces IGCC Plant (Tondou)	TX	Application	Sep 2006	600	Petcoke/coal	Shell	SW 501 F (2)	0.0200	Clean fuel
							Maximum	0.021	
							Minimum	0.001	
							Average	0.006	

\*Based on heat input to the CT.

Source: ECT, 2007.



Table 5-8. H<sub>2</sub>SO<sub>4</sub> Mist BACT Summary of IGCC Projects—Syngas Firing

Facility	State	Application/ Permit	Date	Plant Output (MW)	Gasifier Fuel	Gasifier Make	Combustion Turbine	Syngas BACT Limit (lb/MMBtu)*	BACT Control Method
<b><u>Operating Facilities</u></b>									
Tampa Electric PPS	FL	Operating since 1996		250	Petcoke/bit	GE (Texaco)	GE 7FA	0.024	Clean fuel
Wabash River	IN	Operating since 1995		262	Illinois bit	ConocoPhillips	F Class CTs	Not available	Clean fuel
<b><u>Facilities with Final or Draft Construction Permits</u></b>									
OUC/Southern Stanton Unit B	FL	Final permit	Dec 2006	285	PRB	KBR	GE 7FA (1)	Not available	Clean fuel
Taylorville Energy Center (Erora Gp)	IL	Final permit	Jun 2007	677	Illinois bit	GE (Texaco)	GE 7FA (2)	0.0026	Clean fuel
Lima Energy IGCC (Global Energy)	OH	Final permit	Mar 2002	530	Petcoke/coal	ConocoPhillips	GE 7FA (2)	Not available	Clean fuel
<b><u>Facilities Having Filed Permit Applications</u></b>									
Southern Ill Clean Energy Ctr (Steelhead Ener	IL	Application	Oct 2004	544	Illinois bit	ConocoPhillips	Not available	0.0042	Clean fuel
Excelsior Energy - Mesaba	MN	Application	Jun 2006	531	Petcoke/coal	ConocoPhillips	SW SGT6-5000F	0.0019	Clean fuel
American Electric Power Great Bend (AEP)	OH	Application	Sep 2006	629	Eastern bit	GE (Texaco)	GE 7FB (2)	0.0038	Clean fuel
Applachian Power Mountaineer (AEP)	WV	Application	Sep 2006	600	Eastern bit	GE (Texaco)	GE 7FB (2)	0.0038	Clean fuel
Energy Northwest	WA	Application	Sep 2006	600	Petcoke/coal	ConocoPhillips	SW SGT6-5000F	0.0012	Clean fuel
Nueces IGCC Plant (Tondur)	TX	Application	Sep 2006	600	Petcoke/coal	Shell	SW 501 F (2)	0.0013	Clean fuel
							Maximum	0.0240	
							Minimum	0.0012	
							Average	0.0054	

\*Based on heat input to the gasifier.

Source: ECT, 2007.

Table 5-9. H<sub>2</sub>SO<sub>4</sub> Mist BACT Summary of IGCC Projects—Natural Gas Firing

Facility	State	Application/ Permit	Date	Plant Output (MW)	Gasifier Fuel	Gasifier Make	Combustion Turbine	NG BACT Limit (lb/MMBtu)*	BACT Control Method
<u>Operating Facilities</u>									
Wabash River	IN	Operating since 1995		262	Illinois bit	ConocoPhillips	F Class CT	Not available	Clean fuel
<u>Facilities with Final or Draft Construction Permits</u>									
OUC/Southern Stanton Unit B	FL	Final permit	Dec 2006	285	PRB	KBR	GE 7FA (1)	Not available	Clean fuel
Taylorville Energy Center (Erora Gp)	IL	Final permit	Jun 2007	677	Illinois bit	GE (Texaco)	GE 7FA (2)	0.0001	Clean fuel
Lima Energy IGCC (Global Energy)	OH	Final permit	Mar 2002	530	Petcoke/coal	ConocoPhillips	GE 7FA (2)	0.0003	Clean fuel
<u>Facilities Having Filed Permit Applications</u>									
Southern Ill Clean Energy Ctr (Steelhead Ene	IL	Application	Oct 2004	544	Illinois bit	ConocoPhillips	Not available	Not available	Clean fuel
Excelsior Energy - Mesaba	MN	Application	Jun 2006	531	Petcoke/coal	ConocoPhillips	SW SGT6-5000F	0.0024	Clean fuel
American Electric Power Great Bend (AEP)	OH	Application	Sep 2006	629	Eastern bit	GE (Texaco)	GE 7FB (2)	0.0001	Clean fuel
Appalachian Power Mountaineer (AEP)	WV	Application	Sep 2006	600	Eastern bit	GE (Texaco)	GE 7FB (2)	0.0001	Clean fuel
Energy Northwest	WA	Application	Sep 2006	600	Petcoke/coal	ConocoPhillips	SW SGT6-5000F	Not available	Clean fuel
Nueces IGCC Plant (Tondou)	TX	Application	Sep 2006	600	Petcoke/coal	Shell	SW 501 F (2)	0.0015	Clean fuel
							Maximum	0.002	
							Minimum	0.0001	
							Average	0.001	

\*Based on heat input to the CT.

Source: ECT, 2007.

Table 5-10. Summary of Coal-Fired Power Plant SO<sub>2</sub> BACT Determinations

Plant	State	Permit Date	Unit Number	Boiler Type	Generation Capacity (MW)	Comments	BACT Limits SO <sub>2</sub> (lb/MMBtu)
Springerville Generating Station (Tucson Electric Power Co)	AZ	Apr 2002	3, 4	PC	800	DFGD - SDA	0.600
Plum Point Energy Station (Plum Point Energy Associates, LLC)	AR	8/20/03	1	PC	800	DFGD	0.160
Comanche Plant Unit 3 (Public Service Company of CO)	CO	Jul 2005	3	PC	750	DFGD	0.100
Xcel Energy	CO	Jul 2005		PC	750	DFGD; not subject to PSD review 30-day average	0.100
Indiantown Cogeneration Plant (Indiantown Cogeneration, LP)	FL	1995	1	PC	330	DFGD	0.170
Seminole Electric Unit 3	FL	Draft	3	SCPC	750	WFGD; not subject to PSD review	
Stanton Energy Center (MUA/OUC/FMPA)	FL	1996	2	PC	468	WFGD	0.250
Longleaf Energy Station (LS Power)	GA	Draft	1, 2	PC	600	DFGD 24-hr average	0.120
Holcomb Generating Station (Sand Sage Power, LLC)	KS	4/5/04	2	PC	660	DFGD	0.095
Louisville Gas & Electric	KY	Jan 2006		SCPC	750	WFGD; not subject to PSD review	0.216
Thoroughbred Generating Station (Thoroughbred Generating Co, LLC)	KY	May 2006	1,2	PC	1,500	WFGD	0.410
MidAmerican Energy Center Council Bluffs (MidAmerican Energy)	IA	6/17/03	4	SCPC	750	DFGD	0.100
Baldwin Expansion (Dynergy)	IL	Pending	1,2	PC	750		0.250
Dellman Unit 4 (City Water Light & Power - Springfield, IL) (Not subject to SO <sub>2</sub> or NO <sub>x</sub> BACT)	IL	Draft (Feb 2006)	4	PC	250	Not subject to PSD review	0.200
Prairie State (Prairie State Generating Co, LLC)	IL	Apr 2005	1,2	PC	1,500	WFGD	0.181
Prairie Energy Power Plant (Corn Belt Energy Corporation)	IL	12/17/02	1	PC	91	FGD 30-day rolling average	0.150
Franklin Energy Coal Project (Illinois Energy Group)	IL	Pending	1,2	PC	680		0.080
NRG Energy (Big Cajun II) (Louisiana Generating, LLC)	LA	Aug 2005	2	SCPC	575	WFGD 30-day rolling average	0.100
KCP&L Latan Generating	MO	Jan 2006		PC	850	WFGD	0.100
Weston Bend Generating Station (Great Plains Power Company)	MO	Nov 2001	1	PC	820	DFGD	0.120
Southwest Power Station (City Utilities of Springfield)	MO	12/15/04	2	PC	275	DFGD - SDA	0.095
Roundup Power Project (Bull Mountain Development Co)	MT	7/21/03	1, 2	PC	780	DFGD 24-hour average	0.120
Rocky Mountain Power (Rocky Mountain Power, Inc.)	MT	6/11/02	1	PC	113	DFGD 30-day average	0.110
Montana Dakota Utilities	ND	Jun 2005		PC	220		0.360

Table 5-10. Summary of Coal-Fired Power Plant SO<sub>2</sub> BACT Determinations

Plant	State	Permit Date	Unit Number	Boiler Type	Generation Capacity (MW)	Comments	BACT Limits SO <sub>2</sub> (lb/MMBtu)
Whelan Energy Center (Hastings Utilities)	NE	Mar 2004	1	PC	220	DFGD-SDA	0.120
Nebraska City Unit 2 (Omaha Public Power District)	NE	Mar 2005	2		660	DFGD-SDA 30-day average	0.095
Newmont TS Power Plant (Newmont NV Energy Investment, LLC)	NV	May 2005		PC	200	DFGD	0.090
Desert Rock Energy Facility (Steag Power, LLC)	NM	Pending	1, 2	PC	750	WFGD	0.060
Cottonwood Energy Center (Chaco Valley Energy, LLC)	NM	Pending	1	PC	495		0.060
Mustang Generating Station (Chaco Valley Energy, LLC)	NM	Pending	1	PC	330		0.072
Santee Cooper Cross (Not subject to SO <sub>2</sub> or NO <sub>x</sub> BACT)	SC	2/5/04	3,4	PC	660	WFGD; not subject top BACT review	0.100
Calaveras Plant Spruce Unit 2 (Not subject to SO <sub>2</sub> or NO <sub>x</sub> BACT)	TX	12/05	2	PC	750		0.100
City Public Service	TX	Sep 2005		PC	750	WFGD	0.100
Sandy Creek Energy (LS Power)	TX	Pending	1	PC	500	DFGD	0.120
Intermountain Power (Intermountain Power Service Corp)	UT	10/15/04	3	PC	950	DFGD	0.100
Weston Unit 4 (Wisconsin Public Service Company)	WI	Oct 2004	1	PC	500		0.100
Elm Road Generating Station (We Energy - formerly WEPCO)	WI	1/14/04	1,2	SCPC	1,230	WFGD	0.150
Public Service Corp Wausau	WI	Oct 2004		SCPC	500	DFGD	0.060
Longview Power (Longview Power, LLC)	WV	3/2/04	1	PC	600	WFGD	0.150
WYGEN II (Black Hills Corporation)	WY	Sep 2002	1	PC	500	DFGD 30-day average	0.100
Black Hills (Black Hills Corporation)	WY	Jun 1999	1	PC	80	DFGD 30-day average	0.170
Two Elk (Two Elk Generation Partners, L.P.)	WY	May 2003	1	PC	250		0.132
						Minimum	0.060
						Maximum	0.600
						Average	0.148
						Median	0.110

Source: ECT, 2007.

Table 5-11. Summary of Coal-Fired Power Plant H<sub>2</sub>SO<sub>4</sub> Mist BACT Determinations

Plant	State	Permit Date	Unit Number	Boiler Type	Generation Capacity (MW)	Comments	BACT Limit (lb/MMBtu)
Springerville Generating Station (Tucson Electric Power Co)	AZ	Apr 2002	3, 4	PC	800	Cobenefit controls DFGD/fabric filter	0.6000
Plum Point Energy Station (Plum Point Energy Associates, LLC)	AR	8/20/03	1	PC	800	DFDG/fabric filter	0.0061
Comanche Plant Unit 3 (Public Service Company of CO)	CO	Jul 2005	3	PC	750	As HF	0.0042
Xcel Energy	CO	Jul 2005		PC	750		0.0029
Indiantown Cogeneration Plant (Indiantown Cogeneration, LP)	FL	1995	1	PC	330	Fabric filter	0.0004
Seminole Electric Unit 3	FL	Aug 2006	3	SCPC	750	WFGD/WESP	
Stanton Energy Center (MUA/OUC/FMPA)	FL	1996	2	PC	468		
Longleaf Energy Station (LS Power)	GA	Pending	1, 2	PC	600	DFDG/fabric filter	0.0001
Holcomb Generating Station (Sand Sage Power, LLC)	KS	4/5/04	2	PC	660		0.0040
Louisville Gas & Electric	KY	Jan 2006		SCPC	750	WFGD	0.0038
Thoroughbred Generating Station (Thoroughbred Generating Co, LLC)	KY	May 2006	1,2	PC	1,500	WDGD/WESP	0.0050
MidAmerican Energy Center Council Bluffs (MidAmerican Energy)	IA	6/17/03	4	SCPC	750	Cobenefit controls	0.0042
Baldwin Expansion (Dynergy)	IL	Pending	1.2	PC	750		
Dellman Unit 4 (City Water Light & Power - Springfield, IL) <b>(Not subject to SO<sub>2</sub> or NO<sub>x</sub> BACT)</b>	IL	Draft (Feb 2006)	4	PC	250	3-hour average	0.0050
Prairie State (Prairie State Generating Co, LLC)	IL	Apr 2005	1,2	PC	1,500	WFDG/WESP	0.0050
Prairie Energy Power Plant (Corn Belt Energy Corporation)	IL	12/17/02	1	PC	91	WFDG/WESP	
Franklin Energy Coal Project (Illinois Energy Group)	IL	Pending	1,2	PC	680		
NRG Energy (Big Cajun II) (Louisiana Generating, LLC)	LA	Aug 2005	2	SCPC	575	WFGD/sorbent injection	0.0075
KCP&L Latan Generating	MO	Jan 2006		PC	850		0.0072
Weston Bend Generating Station (Great Plains Power Company)	MO	Nov 2001	1	PC	820		
Southwest Power Station (City Utilities of Springfield)	MO	12/15/04	2	PC	275	Synthetic minor for HAPs	0.0002
Roundup Power Project (Bull Mountain Development Co)	MT	7/21/03	1, 2	PC	780		0.0064
Rocky Mountain Power (Rocky Mountain Power, Inc.)	MT	6/11/02	1	PC	113		0.0063
Montana Dakota Utilities	ND	Jun 2005		PC	220		

Table 5-11. Summary of Coal-Fired Power Plant H<sub>2</sub>SO<sub>4</sub> Mist BACT Determinations

Plant	State	Permit Date	Unit Number	Boiler Type	Generation Capacity (MW)	Comments	BACT Limit (lb/MMBtu)
Whelan Energy Center (Hastings Utilities)	NE	Mar 2004	1	PC	220		0.0004
Nebraska City Unit 2 (Omaha Public Power District)	NE	Mar 2005	2		660	HF 3-hour average	0.0042
Newmont TS Power Plant (Newmont NV Energy Investment, LLC)	NV	May 2005		PC	200		
Desert Rock Energy Facility (Steag Power, LLC)	NM	Pending	1, 2	PC	750	WFGD/sorbent injection 3-hour averages	0.0040
Cottonwood Energy Center (Chaco Valley Energy, LLC)	NM	Pending	1	PC	495		0.0600
Mustang Generating Station (Chaco Valley Energy, LLC)	NM	Pending	1	PC	330		0.0720
Santee Cooper Cross (Not subject to SO <sub>2</sub> or NO <sub>x</sub> BACT)	SC	2/5/04	3,4	PC	660		
Calaveras Plant Spruce Unit 2 (Not subject to SO <sub>2</sub> or NO <sub>x</sub> BACT)	TX	12/05	2	PC	750		0.0037
City Public Service	TX	Sep 2005		PC	750	WFGD	0.0037
Sandy Creek Energy (LS Power)	TX	Pending	1	PC	500		0.0070
Intermountain Power (Intermountain Power Service Corp)	UT	10/15/04	3	PC	950	Cobenefit controls	0.0044
Weston Unit 4 (Wisconsin Public Service Company)	WI	Oct 2004	1	PC	500		0.0050
Elm Road Generating Station (We Energy - formerly WEPCO)	WI	1/14/04	1.2	SCPC	1,230	WESP	0.0100
Public Service Corp Wausau	WI	Oct 2004		SCPC	500	Sorbent onjection/HF	0.0050
Longview Power (Longview Power, LLC)	WV	3/2/04	1	PC	600	Dry sorbent injection, no WESP	0.0075
WYGEN II (Black Hills Corporation)	WY	Sep 2002	1	PC	500		
Black Hills (Black Hills Corporation)	WY	Jun 1999	1	PC	80		
Two Elk (Two Elk Generation Partners, L.P.)	WY	May 2003	1	PC	250		
						Minimum	0.0001
						Maximum	0.6000
						Average	0.0285
						Median	0.0050

Source: ECT, 2007.

### **Syngas Firing (H<sub>2</sub>SO<sub>4</sub> Mist)**

- Emission Limit—12.8 lb/hr.
- Averaging Period—Duration of stack test.
- Compliance Method—Stack test using EPA reference methods.

### **Natural Gas Firing (SO<sub>2</sub> and H<sub>2</sub>SO<sub>4</sub> Mist)**

- Emission Limit—Use of pipeline quality natural gas containing no more than 2.0 gr S/100 scf.
- Averaging Period—Not applicable.
- Compliance Method—Fuel monitoring in accordance with 40 CFR 75.

## **5.4.2 AUXILIARY BOILER**

The 300-MMBtu (HHV) auxiliary boiler will be fired with pipeline-quality natural gas containing no more than 2.0 gr/100 scf of sulfur. The auxiliary boiler will also operate with a capacity factor of no more than 10 percent, which is equivalent to 876 hr/yr operation at design capacity. The use of low-sulfur fuel and limited annual operating hours will result in auxiliary boiler SO<sub>2</sub> emissions of only 0.77 tpy.

In the auxiliary boiler, SO<sub>2</sub> is formed during the combustion process as a result of thermal oxidation of sulfur contained in the natural gas. The only technically and economically feasible technology available to control SO<sub>2</sub> from auxiliary boilers is the use of low-sulfur fuel. Fuel treatment technologies are applied to natural gas to reduce the sulfur content prior to delivery to end fuel users. Since reducing the sulfur content of the fuel combusted in the auxiliary boiler also serves to control H<sub>2</sub>SO<sub>4</sub> mist emissions, the SO<sub>2</sub> and H<sub>2</sub>SO<sub>4</sub> mist BACT emission limit proposed is considered a surrogate BACT limit for H<sub>2</sub>SO<sub>4</sub> mist.

The exclusive use of natural gas and constraints on annual operations are proposed as SO<sub>2</sub> and H<sub>2</sub>SO<sub>4</sub> mist BACT for the auxiliary boiler. The proposed BACT for SO<sub>2</sub> is consistent for that of other recently permitted auxiliary boilers as shown in Table 5-5. SO<sub>2</sub> BACT proposed for the auxiliary boiler is summarized as follows:

- Emission Limit—Use of pipeline quality natural gas containing no more than 2.0 gr S/100 scf.

- Compliance Method—Supplier certifications of fuel sulfur content.
- Annual Heat Input—262,752 MMBtu/yr.
- Averaging Period—Calendar year.
- Compliance Method—Fuel consumption monitoring.

#### 5.4.3 EMERGENCY DIESEL ENGINES

The emergency generator and firewater pump diesel engines will each be fired with ULSD fuel oil containing no more than 0.0015 percent sulfur by weight. Excluding emergencies, each diesel engine will operate no more than 100 hr/yr for routine testing and maintenance purposes. Estimated SO<sub>2</sub> emissions for the three diesel engines are less than 0.002 tpy.

The diesel engines will emit SO<sub>2</sub> due to thermal oxidation of sulfur contained in the fuel oil. The only technically and economically feasible technology available to control SO<sub>2</sub> from emergency diesel engines is the use of low-sulfur fuel oil.

The exclusive use of ULSD fuel oil and constraints on annual operations are proposed as SO<sub>2</sub> BACT for the emergency diesel engines. SO<sub>2</sub> BACT proposed for the emergency diesel engines is summarized as follows:

- Emission Limit—Exclusive use of ULSD fuel oil.
- Compliance Method—Supplier certifications of fuel oil sulfur content.
- Annual Operating Hours—100 hr/yr/engine (excluding emergencies), per engine.
- Averaging Period—Calendar year.
- Compliance Method—Monitoring of operating hours using engine run-time meters.

#### 5.4.4 SULFURIC ACID PLANT

The gas stream from the Selexol™ AGR system will go to a sulfuric acid plant, which will convert the acid gas stream to H<sub>2</sub>SO<sub>4</sub> solution of 93 percent or more. The H<sub>2</sub>SO<sub>4</sub> by-product will be sold to the H<sub>2</sub>SO<sub>4</sub> market. The sulfuric acid plant will be of the dual ab-



sorption contact or wet sulfuric acid (WSA) process design. The contact process incorporates the following three basic operations:

- Sulfur in the feedstock is oxidized (i.e., burned) to form SO<sub>2</sub>.
- The SO<sub>2</sub> is sent to a converter where it is catalytically oxidized to SO<sub>3</sub>.
- The SO<sub>3</sub> is then absorbed in a 93-percent H<sub>2</sub>SO<sub>4</sub> solution to form the H<sub>2</sub>SO<sub>4</sub> product.

In the dual absorption process to be installed for this project, the SO<sub>3</sub> gas formed in the primary converter stages is sent to an interpass absorber where most of the SO<sub>3</sub> is converted to H<sub>2</sub>SO<sub>4</sub>. The remaining unconverted SO<sub>2</sub> is sent to the remaining stages of the converter to remove much of the remaining SO<sub>2</sub> by oxidation to SO<sub>3</sub>, then to the final absorber for removal of the remaining SO<sub>3</sub>. The WSA process will be comparable in performance as the dual absorption technology.

#### **5.4.4.1 Available SO<sub>2</sub> and H<sub>2</sub>SO<sub>4</sub> Mist Control Technologies**

Use of the dual absorption contact process results in a high conversion rate of SO<sub>2</sub> to SO<sub>3</sub> and is considered to be the preferred method to control SO<sub>2</sub> emissions. The dual absorption contact process is capable of achieving SO<sub>2</sub> to SO<sub>3</sub> conversion rates of 99 percent and higher. Although FGD systems in conjunction with a single contact process may be possible, it would result in lower control efficiencies for SO<sub>2</sub> and create residual waste that would need to be disposed. Mist eliminators are the only practical control technology used for control of H<sub>2</sub>SO<sub>4</sub> mist emissions from sulfuric acid plants.

#### **5.4.4.2 Technical Feasibility and Rankings**

The use of a dual absorption contact process is technically feasible for this installation. Mist eliminators are used to control H<sub>2</sub>SO<sub>4</sub> mist emissions from sulfuric acid plants, and are considered to be technically feasible for this application.

#### **5.4.4.3 Evaluation of Control Technologies**

Tampa Electric is proposing to install a dual absorption contact process and mist eliminators for control of SO<sub>2</sub> and H<sub>2</sub>SO<sub>4</sub> mist, respectively. The economic and energy impacts

associated with the installation and operation of these control technologies is considered reasonable. There are no significant collateral environmental issues that would justify rejection of this control technology as BACT.

#### **5.4.4.4 Proposed SO<sub>2</sub> and H<sub>2</sub>SO<sub>4</sub> Mist BACT**

Table 5-12 provides a summary of recent BACT determination of sulfuric acid plants. Tampa Electric is proposing to install dual absorption process with mist eliminators located on the bottom section of the SAP stack to achieve an SO<sub>2</sub> emission rate of 36.7 lb/hr and a H<sub>2</sub>SO<sub>4</sub> mist emission rate of 3.7 lb/hr. These emission limits are equivalent to an SO<sub>2</sub> emission rate of 1.0 lb/ton of 100-percent acid produced, and a H<sub>2</sub>SO<sub>4</sub> emission rate of 0.10 lb/ton of 100-percent acid produced. This is consistent with the lowest H<sub>2</sub>SO<sub>4</sub> mist emission rates for recent BACT determinations and significantly lower than the top case for SO<sub>2</sub>. These emission rates are also lower than the NSPS for sulfuric acid plants contained in 40 CFR Subpart H, Standards of Performance for Sulfuric Acid Plants. The NSPS limits are 4.0 lb SO<sub>2</sub> per ton of H<sub>2</sub>SO<sub>4</sub> produced, and 0.15 lb of H<sub>2</sub>SO<sub>4</sub> mist per ton of H<sub>2</sub>SO<sub>4</sub> produced.

### **5.5 BACT ANALYSIS FOR CO**

#### **5.5.1 CT/HRSG**

##### **5.5.1.1 Available CO Control Technologies**

There are two available technologies for controlling CO from the CT/HRSG units: combustion process design and oxidation catalysts.

#### **Combustion Process Design**

Combustion process controls involve combustion chamber designs and operation practices that improve the oxidation process and minimize incomplete combustion. CO emissions result from the incomplete combustion of carbon and organic compounds. Factors affecting CO emissions include firing temperatures, residence time in the combustion

Table 5-12. Recent BACT Determinations for Sulfuric Acid Plants

RBLC ID	Company Name	Permit Date	Plant Capacity (ton/day)	SO <sub>2</sub> (lb/ton)	Control/Efficiency	H <sub>2</sub> SO <sub>4</sub> Mist (lb/ton)	Control/Efficiency
FL-0260	CF Industries, Inc.	06/01/04	3,000	3.5	Dual absorption/ 99.5%	0.10	Mist eliminators/ 99%
NC-0088	PCS Phosphate Co.	09/24/03	1,850	4.0	Dual absorption	0.10	Mist eliminators
FL-0253	IMC Phosphates MP, Inc.	07/12/02	3,400	3.5	Dual absorption/ 99%	0.10	Mist eliminators/ 99%
FL-0237	US Agri-Chemicals Corp.	02/06/01	3,000	3.5	Dual absorption/ 99.9%	0.12	Mist eliminators/ 99%
NC-0099	PCS Phosphate Co.	07/14/00	2,000	4.0	Dual absorption	0.15	Mist eliminators and mesh pad
FL-0129	Farmland Hydro, L.P.	03/08/99	2,750	3.5	Dual absorption	Not applicable	Mist eliminators
FL-0197	Cargill Fertilizer, Inc.	10/16/98	3,200	3.5	Dual absorption	0.12	Mist eliminators
FL-0194	Piney Point Phosphates	02/17/98	2,000	3.5	Dual absorption/ 95%	0.15	Mist eliminators/ 98%
FL-0210	IMC Agrico	09/17/97	3,000	4.0	Dual absorption	0.15	Mist eliminators
FL-0172	Mulberry Phosphates, Inc.	08/06/97	Not applicable	4.0	Dual absorption	0.15	Mist eliminators

Note: Emission rate in standardized units of pounds per ton of 100-percent H<sub>2</sub>SO<sub>4</sub> acid produced.

Source: ECT, 2007.

5-52

zone, and combustion chamber mixing characteristics. Because higher combustion temperatures will increase oxidation rates, emission rates of CO will generally increase during CT partial load conditions when combustion temperatures are lower. Decreased combustion zone temperature due to the injection of water or steam for NO<sub>x</sub> control should also result in an increase in CO emissions. An increase in combustion zone residence time and improved mixing of fuel and combustion air will increase oxidation rates and cause a decrease in CO emission rates. In general, emissions of NO<sub>x</sub> and CO are inversely related (i.e., decreasing NO<sub>x</sub> emissions will result in an increase in CO emissions).

CT combustors are designed to minimize CO formation since CO emissions are indicative of inefficient combustion and unused energy. Due to its high combustion temperatures, a CT essentially functions as a thermal oxidizer achieving inherently low CO and VOC emissions.

### **Oxidation Catalysts**

Noble metal (commonly platinum or palladium) oxidation catalysts are used to promote oxidation of CO to CO<sub>2</sub> and water at temperatures approximately 50 percent lower than would be necessary for oxidation without a catalyst. The operating temperature range for conventional oxidation catalysts is between 650 and 1,150°F. For natural gas-fired combined-cycle units, the oxidation catalyst would be located within the HRSG where temperatures range from 450 to 1,100°F.

Efficiency of CO oxidation varies with inlet temperature. Control efficiency will increase with increasing temperature for CO up to a temperature of approximately 1,100°F; further temperature increases will have little effect on control efficiency. Significant CO oxidation will occur at any temperature above roughly 500°F. Inlet temperature must be maintained below 1,350 to 1,400°F to prevent thermal aging of the catalyst that will reduce catalyst activity and pollutant removal efficiencies. Removal efficiency will also vary with gas residence time, which is a function of catalyst bed depth. Increasing bed depth will increase removal efficiencies but will also cause an increase in pressure drop

across the catalyst bed. For natural gas-fired combined-cycle applications, oxidation catalyst systems are typically designed to achieve a control efficiency of 80 to 90 percent for CO. No such data exists for CO removal efficiencies for coal-fired IGCCs.

Oxidation catalysts are susceptible to deactivation due to impurities present in the exhaust gas stream. Arsenic, iron, sodium, phosphorous, and silica will all act as catalyst poisons, causing a reduction in catalyst activity and pollutant removal efficiencies.

Oxidation catalysts are nonselective and will oxidize other compounds in addition to CO. The nonselectivity of oxidation catalysts is important in assessing applicability to exhaust streams containing sulfur compounds. An oxidation catalyst system may convert up to 40 percent of the CT exhaust stream  $\text{SO}_2$  to  $\text{SO}_3$  depending on the exhaust stream temperature. If ammonia is also present as a result of an SCR control system,  $\text{SO}_3$  and ammonia will react to form ABS. If ammonia is not present,  $\text{SO}_3$  will combine with moisture in the gas stream to form  $\text{H}_2\text{SO}_4$  mist. Due to the oxidation of  $\text{SO}_2$  and excessive formation of either ABS or  $\text{H}_2\text{SO}_4$  mist emissions, oxidation catalysts are not considered to be an appropriate control technology for combustion devices that are fired with fuels containing significant amounts of sulfur.

To date, there are no oxidation catalyst installations on any IGCC unit.

#### **5.5.1.2 Technical Feasibility**

Proper CT combustor design and operation (i.e., good combustion practice [GCP]) is considered to be a technically feasible control technology for the Unit 6 CTs for both syngas and natural gas firing and has been demonstrated for both fuel types.

Oxidation catalysts have not been demonstrated on any IGCC unit. As noted previously, oxidation catalysts are susceptible to deactivation due to a variety of impurities. Due to the lack of operating experience and potential catalyst deactivation, the performance and reliability of oxidation catalyst controls applied to syngas fired CT/HRSGs are unknown.

Oxidation catalyst systems, which are typically located in a HRSG upstream of the SCR reactor due to temperature considerations, will oxidize NO to NO<sub>2</sub>. The additional NO<sub>2</sub> formed will, in turn, require an increase in ammonia injection rates since the SCR catalytic process requires greater amounts of ammonia to reduce NO<sub>2</sub> to molecular nitrogen compared to NO reduction. Accordingly, an oxidation catalyst system will exacerbate the problems associated with HRSG sulfate deposition due to the required increase in ammonia injection rates.

Use of oxidation catalyst controls for the Unit 6 CT/HRSGs is not transferable from a natural gas-fired CC unit for the following reasons:

- Unit 6 will be a baseload generation facility and therefore must achieve the capacity factors, availability, and reliability associated with baseload units. Any control system that causes forced outages, increases maintenance outage rates, or reduces unit efficiency appreciably is unacceptable since it would prevent Unit 6 from serving its intended purpose as a baseload generation unit.
- One of the challenges in operating SCR technology is minimization of ammonia slip. Ammonia slip will react with SO<sub>3</sub> present to form ABS, a sticky liquid that will foul the HRSG heat transfer surfaces, resulting in reduced reliability, availability and efficiency.
- Use of oxidation catalyst will significantly exacerbate the formation of ABS by substantially increasing SO<sub>3</sub>, as up to 40 percent of SO<sub>2</sub> may be oxidized to SO<sub>3</sub> by an oxidation catalyst. During syngas firing, this will significantly increase the formation of ABS.
- The treated Unit 6 syngas will contain trace elements not found in natural gas that could potentially reduce oxidation catalyst activity and performance. Currently, there are no oxidation catalyst control systems installed on an operating IGCC facility, or on pulverized coal-fired power plants. Accordingly, the long-term performance of an oxidation catalyst system applied to a coal-derived syngas-fired CT/HRSG unit is unknown.

- Although oxidation catalyst technology is considered technically feasible for natural gas-fired CT/HRSG units, it is not feasible for Unit 6 when firing natural gas since the HRSGs must be available when the CT is fired with either syngas or natural gas. As a baseload unit, it would not be practical to install an oxidation catalyst system that would only be used during natural gas-firing (i.e., this approach would require extended outages to remove and replace the catalyst from the HRSG each time the CT fuel is changed from syngas to natural gas).
- No other planned IGCC project has proposed the use of oxidation catalyst due to concerns with SO<sub>2</sub> oxidation and fouling of HRSG heat transfer surfaces caused by sulfur compound deposits. In its review of the Taylorville Energy Center project, the Illinois EPA concluded that GCP constituted BACT for CO. The Illinois EPA recently issued a construction permit for the Taylorville Energy Center on June 5, 2007.
- Tampa Electric has been unable to obtain any guarantees with respect to the frequency of HRSG cleanings required due to the installation of an oxidation catalyst control system. Bechtel indicates that, to their knowledge, no oxidation catalyst vendors are willing to offer a HRSG cleaning frequency guarantee for an IGCC facility. Similarly, GE has indicated to Tampa Electric that they are not in a position to make any representation as to the number of cleanings required or frequencies between cleanings should Unit 6 be equipped with an oxidation catalyst.
- Based on an analysis of GE data, an oxidation catalyst control system would be expected to result in approximately four HRSG cleanings per year conservatively assuming a very low syngas sulfur content of 20 ppmvd. The O&M and replacement power costs associated with this frequency of HRSG cleanings would be prohibitive.

Based on the above, oxidation catalyst technology is not considered technically feasible for syngas-fired CT/HRSG units.

### **5.5.1.3 Proposed CO BACT**

Tampa Electric proposes CO BACT emission limits of 94 lb/hr (when firing syngas) and 81 lb/hr (when firing natural gas), on a 24-hour rolling average basis for each CT/HRSG unit. For syngas-firing, the proposed CO BACT emission limit is equivalent to 14 ppmvd at 15 percent oxygen, 0.23 lb/MWh (gross), and 0.030 lb/MMBtu (gasifier heat input basis). For natural gas-firing, the proposed CO BACT emission limit is equivalent to 20 ppmvd at 15 percent oxygen, and 0.045 lb/MMBtu (CT heat input basis).

The proposed CO BACT limits reflect GCP technology and are consistent with recent BACT determinations for similar IGCC projects. The proposed CO BACT limit for syngas-firing is also significantly lower than the rates recently proposed for state-of-the-art PC projects. For example, the Taylor Energy Center project proposed a CO BACT limit of 0.15 lb/MMBtu, five times higher than the limit proposed for Unit 6.

Recent CO BACT determinations for syngas and natural gas fired CTs are based on the use of clean fuels and GCP. Tables 5-13 and 5-14 provide recent CO BACT determinations for CTs fired with syngas and natural gas, respectively. Table 5-15 provides recent CO BACT determinations for bituminous pulverized coal units. All syngas-fired CT and bituminous coal-fired unit CO BACT determinations are based on GCT. With few exceptions, GCT has also been determined as CO BACT for natural gas-fired CTs. Oxidation catalysts have been required in cases where CO emissions may be elevated due to planned part load CT operations and/or steam augmentation (e.g., the proposed Calpine Blue Heron project). Regarding Florida CO BACT determinations for combined-cycle units, of note is the determination made by FDEP for the Seminole Electric Cooperative Payne Creek Generating Station. This facility includes two dual fuel (natural gas and distillate fuel oil) Siemens Westinghouse 501F(D) CTs operating in combined-cycle mode. The HRSGs are equipped with both oxidation catalyst and SCR control systems. However, due to concerns with ABS formation, the SCR control systems are *not* required to be functional during combustion of distillate fuel oil (i.e., the permit limit for NO<sub>x</sub> during oil-firing does not require use of the SCR system).



Table 5-13. CO BACT Summary of IGCC Projects—Syngas Firing

Facility	State	Application/ Permit	Date	Plant Output (MW)	Gasifier Fuel	Gasifier Make	Combustion Turbine	Syngas BACT Limit (lb/MMBtu)*	BACT Control Method
<u>Operating Facilities</u>									
Tampa Electric PPS	FL	Operating since 1996		250	Petcoke/bit	GE (Texaco)	GE 7FA	0.045	GCP
Wabash River	IN	Operating since 1995		262	Illinois bit	ConocoPhillips	F Class CT	0.036	GCP
<u>Facilities with Final or Draft Construction Permits</u>									
OUC/Southern Stanton Unit B	FL	Final permit	Dec 2006	285	PRB	KBR	GE 7FA (1)	0.0378	GCP
Taylorville Energy Center (Erora Gp)	IL	Final permit	Jun 2007	677	Illinois bit	GE (Texaco)	GE 7FA (2)	0.035	GCP
Lima Energy IGCC (Global Energy)	OH	Final permit	Mar 2002	530	Petcoke/coal	ConocoPhillips	GE 7FA (2)	0.035	GCP
<u>Facilities Having Filed Permit Applications</u>									
Southern Ill Clean Energy Ctr (Steelhead Ene	IL	Application	Oct 2004	544	Illinois bit	ConocoPhillips	Not available	0.040	GCP
Excelsior Energy - Mesaba	MN	Application	Jun 2006	531	Petcoke/coal	ConocoPhillips	SW SGT6-5000F	0.033	GCP
American Electric Power Great Bend (AEP)	OH	Application	Sep 2006	629	Eastern bit	GE (Texaco)	GE 7FB (2)	0.031	GCP
Appalachian Power Mountaineer (AEP)	WV	Application	Sep 2006	600	Eastern bit	GE (Texaco)	GE 7FB (2)	0.031	GCP
Energy Northwest	WA	Application	Sep 2006	600	Petcoke/coal	ConocoPhillips	SW SGT6-5000F	0.036	GCP
Nueces IGCC Plant (Tondur)	TX	Application	Sep 2006	600	Petcoke/coal	Shell	SW SGT6-5000F	0.037	GCP
							Maximum	0.045	
							Minimum	0.031	
							Average	0.036	

\*Based on heat input to the gasifier.

Source: ECT, 2007.

5-58

Table 5-14. CO BACT Summary of IGCC Projects—Natural Gas Firing

Facility	State	Application/ Permit	Date	Plant Output (MW)	Gasifier Fuel	Gasifier Make	Combustion Turbine	NG BACT Limit (lb/MMBtu)*	BACT Control Method
<u>Operating Facilities</u>									
Wabash River	IN	Operating since 1995		262	Illinois bit	ConocoPhillips	F Class CT	Not available	GCP
<u>Facilities with Final or Draft Construction Permits</u>									
OUC/Southern Stanton Unit B	FL	Final permit	Dec 2006	285	PRB	KBR	GE 7FA (1)	0.028	GCP
Taylorville Energy Center (Erora Gp)	IL	Final permit	Jun 2007	677	Illinois bit	GE (Texaco)	GE 7FA (2)	0.045	GCP
Lima Energy IGCC (Global Energy)	OH	Final permit	Mar 2002	530	Petcoke/coal	ConocoPhillips	GE 7FA (2)	0.136	GCP
<u>Facilities Having Filed Permit Applications</u>									
Southern Ill Clean Energy Ctr (Steelhead Ene	IL	Application	Oct 2004	544	Illinois bit	ConocoPhillips	Not available	0.028	GCP
Excelsior Energy - Mesaba	MN	Application	Jun 2006	531	Petcoke/coal	ConocoPhillips	SW SGT6-5000F	0.032	GCP
American Electric Power Great Bend (AEP)	OH	Application	Sep 2006	629	Eastern bit	GE (Texaco)	GE 7FB (2)	Not available	GCP
Appalachian Power Mountaineer (AEP)	WV	Application	Sep 2006	600	Eastern bit	GE (Texaco)	GE 7FB (2)	Not available	GCP
Energy Northwest	WA	Application	Sep 2006	600	Petcoke/coal	ConocoPhillips	SW SGT6-5000F	0.035	GCP
Nueces IGCC Plant (Tondou)	TX	Application	Sep 2006	600	Petcoke/coal	Shell	SW 501 F (2)	0.044	GCP
							Maximum	0.136	
							Minimum	0.028	
							Average	0.050	

\*Based on heat input to the CT.

Source: ECT, 2007.

Table 5-15. Summary of Coal-Fired Power Plant CO BACT Determinations

Plant	State	Permit Date	Unit Number	Boiler Type	Generation Capacity (MW)	Comments	BACT Limits (lb/MMBtu)
Springerville Generating Station (Tucson Electric Power Co)	AZ	Apr 2002	3, 4	PC	800	VOC limit = 0.06 lb/ton coal combusted Combustion controls	0.135
Plum Point Energy Station (Plum Point Energy Associates, LLC)	AR	8/20/03	1	PC	800	Combustion controls	0.160
Comanche Plant Unit 3 (Public Service Company of CO)	CO	Jul 2005	3	PC	750	Combustion controls	0.130
Xcel Energy	CO	Jul 2005		PC	750	Combustion controls	0.150
Indiantown Cogeneration Plant (Indiantown Cogeneration, LP)	FL	1995	1	PC	330		0.110
Seminole Electric Unit 3	FL	Aug 2006	3	SCPC	750	Coal only, combustion controls	0.150
Stanton Energy Center (MUA/OUC/FMPA)	FL	1996	2	PC	468		0.150
Longleaf Energy Station (LS Power)	GA	Pending	1, 2	PC	600	CO 30-day rolling average VOC 3-hour average	0.150
Holcomb Generating Station (Sand Sage Power, LLC)	KS	4/5/04	2	PC	660	Combustion controls	0.150
Louisville Gas & Electric	KY	Jan 2006		SCPC	750	CO 30-day average, VOC 3-hour average	0.100
Thoroughbred Generating Station (Thoroughbred Generating Co. LLC)	KY	May 2006	1,2	PC	1,500	Combustion controls	0.100
MidAmerican Energy Center Council Bluffs (MidAmerican Energy)	IA	6/17/03	4	SCPC	750	Combustion controls	0.154
Baldwin Expansion (Dynergy)	IL	Pending	1,2	PC	750		0.154
Dellman Unit 4 (City Water Light & Power - Springfield, IL) (Not subject to SO <sub>2</sub> or NO <sub>x</sub> BACT)	IL	Draft (Feb 2006)	4	PC	250	CO 3-hour average	0.120
Prairie State (Prairie State Generating Co. LLC)	IL	Apr 2005	1,2	PC	1,500	Combustion controls	0.120
Prairie Energy Power Plant (Corn Belt Energy Corporation)	IL	12/17/02	1	PC	91	CO 30-day rolling average	0.200
Franklin Energy Coal Project (Illinois Energy Group)	IL	Pending	1,2	PC	680		0.200
NRG Energy (Big Cajun II) (Louisiana Generating, LLC)	LA	Aug 2005	2	SCPC	575	Combustion controls	0.135
KCP&L Latan Generating	MO	Jan 2006		PC	850	Combustion controls	0.140
Weston Bend Generating Station (Great Plains Power Company)	MO	Nov 2001	1	PC	820		0.160
Southwest Power Station (City Utilities of Springfield)	MO	12/15/04	2	PC	275	Combustion controls	0.160
Roundup Power Project (Bull Mountain Development Co)	MT	7/21/03	1, 2	PC	780	Combustion controls	0.150
Rocky Mountain Power (Rocky Mountain Power, Inc.)	MT	6/11/02	1	PC	113		0.150
Montana Dakota Utilities	ND	Jun 2005		PC	220	3-hour average	0.154
Whelan Energy Center (Hastings Utilities)	NE	Mar 2004	1	PC	220	Combustion controls	0.150

Table 5-15. Summary of Coal-Fired Power Plant CO BACT Determinations

Plant	State	Permit Date	Unit Number	Boiler Type	Generation Capacity (MW)	Comments	BACT Limits (lb/MMBtu)
Nebraska City Unit 2 (Omaha Public Power District)	NE	Mar 2005	2		660	Combustion controls CO 3-hour average	0.160
Newmont TS Power Plant (Newmont NV Energy Investment, LLC)	NV	May 2005		PC	200	Combustion controls 24-hour rolling average	0.150
Desert Rock Energy Facility (Steag Power, LLC)	NM	Pending	1, 2	PC	750	24-hour averages	0.100
Cottonwood Energy Center (Chaco Valley Energy, LLC)	NM	Pending	1	PC	495		0.140
Mustang Generating Station (Chaco Valley Energy, LLC)	NM	Pending	1	PC	330		0.160
Santee Cooper Cross (Not subject to SO <sub>2</sub> or NO <sub>x</sub> BACT)	SC	2/5/04	3,4	PC	660	3-hour averages	0.160
Calaveras Plant Spruce Unit 2 (Not subject to SO <sub>2</sub> or NO <sub>x</sub> BACT)	TX	12/05	2	PC	750		0.150
City Public Service	TX	Sep 2005		PC	750	Combustion controls	0.150
Sandy Creek Energy (LS Power)	TX	Pending	1	PC	500		0.150
Intermountain Power (Intermountain Power Service Corp)	UT	10/15/04	3	PC	950	Combustion controls	0.150
Weston Unit 4 (Wisconsin Public Service Company)	WI	Oct 2004	1	PC	500		0.150
Elm Road Generating Station (We Energy - formerly WEPCO)	WI	1/14/04	1.2	SCPC	1,230	Combustion controls	0.120
Public Service Corp Wausau	WI	Oct 2004		SCPC	500	Combustion controls	0.150
Longview Power (Longview Power, LLC)	WV	3/2/04	1	PC	600	Combustion controls	0.110
WYGEN II (Black Hills Corporation)	WY	Sep 2002	1	PC	500		0.150
Black Hills (Black Hills Corporation)	WY	Jun 1999	1	PC	80		0.150
Two Elk (Two Elk Generation Partners, L.P.)	WY	May 2003	1	PC	250		0.135
						Minimum	0.100
						Maximum	0.200
						Average	0.144
						Median	0.150

Source: ECT, 2007.

Because CO emission rates from CTs are inherently low, further reductions through the use of oxidation catalysts will result in minimal air quality improvements. The only potential benefit of CO oxidation catalyst is to prevent the possible formation of a localized area with elevated concentrations of CO. The catalyst does not remove CO but rather accelerates the natural atmospheric oxidation of CO to CO<sub>2</sub>. Dispersion modeling of CO emissions from Unit 6 shows that maximum CO impacts, without oxidation catalyst, will be insignificant. Unit 6 will be located in an area (Polk County, Florida) that is classified attainment for all criteria pollutants. In 2004, maximum ambient air quality CO concentrations for sites in Hillsborough County were only 14 and 33 percent of the 1- and 8-hour AAQS, respectively. There have been no recorded exceedances of the CO AAQS anywhere in Florida for more than 15 years.

As shown in Tables 5-13 and 5-14, the Unit 6 CT/HRSGs CO emissions compare favorably with prior BACT determinations at other IGCC facilities and are significantly lower than those at PC plants. The CO BACT emission limits proposed for each Unit 6 CT/HRSG unit are summarized as follows:

**Syngas Firing**

- Emission Limit—94 lb/hr.
- Averaging Period—24-hour rolling average.
- Compliance Method—Continuous emissions monitoring.

**Natural Gas Firing**

- Emission Limit—81 lb/hr.
- Averaging Period—24-hour rolling average.
- Compliance Method—Continuous emissions monitoring.

**5.5.2 AUXILIARY BOILER**

The formation mechanism of CO, available control technologies, and control technology technical feasibility described for the CTs also generally apply to the auxiliary boiler.

The only CO control technology considered technically feasible for the natural gas-fired auxiliary boiler is GCP.

Good combustion design and operation, and constraints on annual operations are proposed as CO BACT for the Unit 6 auxiliary boiler. CO BACT emission limits proposed for the auxiliary boiler is summarized as follows:

- Emission Limits—10.8 lb/hr.
- Averaging Period—Stack test duration.
- Compliance Method—Stack test using EPA reference methods.
- Annual Heat Input—262,752 MMBtu/yr.
- Averaging Period—Calendar year.
- Compliance Method—Fuel consumption monitoring.

The proposed BACT limit of 10.8 lb/hr is equivalent to the lowest of the recently permitted auxiliary boilers as shown in Table 5-5.

### **5.5.3 EMERGENCY DIESEL ENGINES**

The formation mechanism of CO, available control technologies, and control technology technical feasibility described for the CTs also generally apply to the emergency diesel engines. Excluding emergencies, each diesel engine will operate no more than 100 hr/yr for routine testing and maintenance purposes. Estimated CO emissions for the three diesel engines are less than 1.0 tpy.

The only CO control technology considered technically feasible for the Unit 6 oil-fired emergency diesel engines is GCP.

Good combustion design and operation, and constraints on annual operations are proposed as CO BACT for the emergency diesel engines. The emergency diesel engines will be subject to the applicable emission standards of NSPS Subpart IIII for new nonroad CI engines. Subpart IIII limits CO emissions to 3.5 g/kW-hr for emergency generators purchased in 2007 or later. Subpart IIII also limits emissions of CO from firewater pump diesel engines—the specific emission limits (Tier II or III) are dependent upon the model year in which the firewater pump diesel engine was manufactured. Tampa Electric will

use emergency diesel engines that comply with the emission standards of NSPS Subpart III.

CO BACT proposed for the Unit 6 emergency diesel engines are summarized as follows:

- Emission Limit—Applicable standards of NSPS Subpart III.
- Averaging Period—Per NSPS Subpart III.
- Compliance Method—Engine manufacturer certification in accordance with NSPS Subpart III.
- Annual Operating Hours—100 hr/yr/engine (excluding emergencies), per engine.
- Averaging Period—Calendar year.
- Compliance Method—Monitoring of operating hours using engine run-time meters.

#### **5.6 BACT ANALYSIS FOR PM/PM<sub>10</sub>**

PM is classified by particle size and is defined by the test methods used to measure stack emissions. Filterable PM is measured using EPA Reference Methods 5, 5B, or 17, which capture particles greater than 0.3 micron in size using a filter that is weighed prior to and following the stack test to determine the gain in weight. In Method 5, the filter is located in the sampling train external to the stack and maintained at a temperature of 248°F. A variation of Method 5 is Method 5B, which maintains the filter temperature at 320°F to exclude H<sub>2</sub>SO<sub>4</sub> PM. Method 17 places the filter in the stack and therefore collects PM at the prevailing stack temperature. Filterable PM<sub>10</sub> is measured using either EPA Reference Methods 201 or 201A. Both of these test methods collect filterable PM with a nominal aerodynamic diameter of 10 microns or less using an in-stack cyclone and filter system. All of the filterable PM test methods, commonly referred to as front-half PM, determine the mass of PM that condenses at or above the filter temperature.

EPA also includes condensable PM as a component of PM<sub>10</sub>. Condensable PM is collected using EPA Reference Method 202 by passing the filtered sample gas stream through a series of chilled water-filled impingers to maintain an impinger outlet sample

gas temperature of 68°F or less. Following sampling, the impinger solution is purged with nitrogen and extracted with methylene chloride. The organic and water fractions are then evaporated and the residues weighed to determine the mass of condensable PM. Since the impingers are located in the sampling train downstream of the filter, condensable PM is also referred to as back-half particulate.

In summary, PM includes the filterable portion of PM as measured by EPA Reference Methods 5, 5B, or 17. PM<sub>10</sub> includes filterable PM less than 10 microns as measured by EPA Reference Methods 201 or 201A and condensable PM as measured by EPA Reference Method 202. Since PM<sub>10</sub> includes condensable particulate and PM does not, PM emission sources will have higher PM<sub>10</sub> emissions compared to PM. For fossil-fuel combustion sources, PM<sub>10</sub> emission rates are approximately double that of PM emissions. Accordingly, the distinction between PM and PM<sub>10</sub> is important when assessing BACT for fossil fuel-fired combustion sources.

### **5.6.1 CT/HRSG**

Due to their low ash and sulfur contents, syngas and natural gas combustion generate inherently low PM/PM<sub>10</sub> emissions.

#### **5.6.1.1 Available PM/PM<sub>10</sub> Control Technologies**

Available technologies used for controlling PM/PM<sub>10</sub> include the following:

- Centrifugal collectors.
- Fabric filters or baghouses.
- Electrostatic precipitators (ESPs).
- Wet scrubbers.

#### **Centrifugal Collectors**

Centrifugal (cyclone) separators are primarily used to recover material from an exhaust stream before the stream is ducted to the principal control device since cyclones are effective in removing only large sized (greater than 10 microns) particles. Particles generated from natural gas combustion are typically less than 1.0 micron in size.



### **ESPs**

ESPs remove particles from a gas stream through the use of electrical forces. Discharge electrodes apply a negative charge to particles passing through a strong electrical field. These charged particles then migrate to a collecting electrode having an opposite, or positive, charge. Collected particles are removed from the collecting electrodes by periodic mechanical rapping of the electrodes. Collection efficiencies are typically 95 percent for particles smaller than 2.5 microns in size.

### **Fabric Filters**

A fabric filter system consists of a number of filtering elements, bag cleaning system, main shell structure, dust removal system, and fan. PM/PM<sub>10</sub> is filtered from the gas stream by various mechanisms (inertial impaction, impingement, accumulated dust cake sieving, etc.) as the gas passes through the fabric filter. Accumulated dust on the bags is periodically removed using mechanical or pneumatic means. In pulse jet pneumatic cleaning, a sudden pulse of compressed air is injected into the top of the bag. This pulse creates a traveling wave in the fabric that separates the cake from the surface of the fabric. The cleaning normally proceeds by row, all bags in the row being cleaned simultaneously. Typical air-to-cloth ratios range from 2 to 8 cubic feet per minute-square foot (cfm-ft<sup>2</sup>). Collection efficiencies are on the order of 99 percent for particles smaller than 2.5 microns in size.

### **Wet Scrubbers**

Wet scrubbers remove PM/PM<sub>10</sub> from gas streams principally by inertial impaction of the particulate onto a water droplet. Particles can be wetted by impingement, diffusion, or condensation mechanisms. To be wetted, PM/PM<sub>10</sub> must either make contact with a spray droplet or impinge upon a wet surface. In a venturi scrubber, the gas stream is constricted in a throat section. The large volume of gas passing through a small constriction gives a high gas velocity and a high-pressure drop across the system. As water is introduced into the throat, the gas is forced to move at a higher velocity causing the water to shear into droplets. Particles in the gas stream then impact onto the water droplets produced. The entrained water droplets are subsequently removed from the gas stream by a cyclone

separator. Venturi scrubber collection efficiency increases with increasing pressure drops for a given particle size. Collection efficiency will also increase with increasing liquid-to-gas ratios up to the point where flooding of the system occurs. Packed-bed and venturi scrubber collection efficiencies are typically 90 percent for particles smaller than 2.5 microns in size.

#### **5.6.1.2 Technical Feasibility and Ranking**

None of the previously described control technologies have been applied to IGCCs or to natural gas CC units because exhaust gas PM/PM<sub>10</sub> concentrations are inherently low. CTs operate with a significant amount of excess air, which generates large exhaust gas flow rates. The Unit 6 CTs will be fired with either syngas or natural gas. The syngas has previously been subject to high efficiency PM/PM<sub>10</sub> removal as part of the gasification process. Combustion of syngas and natural gas will generate low PM/PM<sub>10</sub> emissions in comparison to other fuels due to their low ash and sulfur contents. The minor PM/PM<sub>10</sub> emissions coupled with a large volume of exhaust gas produces extremely low exhaust stream PM/PM<sub>10</sub> concentrations. The estimated PM/PM<sub>10</sub> exhaust concentrations for Unit 6 CT/HRSGs at baseload are approximately 0.008 and 0.004 grains per dry standard cubic foot (gr/dscf) while firing syngas and natural gas, respectively. Exhaust stream PM/PM<sub>10</sub> concentrations of such low magnitude are not amenable to control using available technologies because removal efficiencies would be unreasonably low. In addition, such low removal efficiencies would not justify the significant cost of employing these technologies.

#### **5.6.1.3 Evaluation of Control Technologies**

The use of clean low sulfur, low ash content fuels (i.e., syngas and natural gas) is the only feasible control technology for PM/PM<sub>10</sub> emissions.

#### **5.6.1.4 Proposed PM/PM<sub>10</sub> BACT**

Tampa Electric proposes a total (filterable and condensable) PM/PM<sub>10</sub> BACT emission limit of 39 lb/hr on a 3-hour average basis (when firing syngas), and use of pipeline quality natural gas containing no more than 2.0 gr S/100 scf (when firing natural gas). For

syngas-firing, the proposed PM/PM<sub>10</sub> BACT emission limit is equivalent to 0.096 lb/MWh (gross), and 0.013 lb/MMBtu (gasifier heat input basis).

Recent PM/PM<sub>10</sub> BACT determinations for syngas and natural gas fired CTs are based on the use of clean fuels and GCP. Tables 5-16 and 5-17 provide recent PM/PM<sub>10</sub> BACT determinations for CTs fired with syngas and natural gas for each CT/HRSG unit, respectively. Since the syngas fired in the Unit 6 CTs results from the gasification of coal and petcoke, a comparison of the emissions performance of Unit 6 with bituminous coal fired boilers is relevant inasmuch as the Unit 6 IGCC process represents an alternative to conventional coal-fired power plants. Table 5-18 provides recent PM/PM<sub>10</sub> BACT determinations for bituminous pulverized coal-fired units. As shown in Tables 5-16 and 5-17, Unit 6 CT PM/PM<sub>10</sub> emissions compare favorably with prior BACT determinations.

Because postprocess stack controls for PM/PM<sub>10</sub> are not appropriate for CC units, the use of GCPs and clean fuels is considered to be BACT. Unit 6 CTs will be fired with either syngas or natural gas. The PM BACT emission limits proposed for each Unit 6 CT/HRSG unit are summarized as follows:

**Syngas Firing**

- Emission Limit—39 lb/hr.
- Averaging Period—Duration of stack test.
- Compliance Method—Stack testing using EPA reference methods.

**Natural Gas Firing**

- Emission Limit—Use of pipeline quality natural gas containing no more than 2.0 gr S/100 scf.
- Averaging Period—Not applicable.
- Compliance Method—Fuel sampling.

The proposed total PM/PM<sub>10</sub> BACT limit for syngas-firing is significantly lower than the rates recently proposed for state-of-the-art PC projects. For example, the Taylor Energy Center project proposed a total PM/PM<sub>10</sub> BACT limit of 0.025 lb/MMBtu, approximately two times higher than the limit proposed for Unit 6.

Table 5-16. PM BACT Summary of IGCC Projects—Syngas Firing

Facility	State	Application/ Permit	Date	Plant Output (MW)	Gasifier Fuel	Gasifier Make	Combustion Turbine	Syngas BACT Limit (lb/MMBtu)*	BACT Control Method	Limit Basis
<b>Operating Facilities</b>										
Tampa Electric PPS	FL	Operating since 1996		250	Petcoke/bit	GE (Texaco)	GE 7FA	0.008	Clean fuel	F
Wabash River	IN	Operating since 1995		262	Illinois bit	ConocoPhillips	F Class CTs	0.001	Clean fuel	N/A
<b>Facilities with Final or Draft Construction Permits</b>										
OUC/Southern Stanton Unit B	FL	Final permit	Dec 2006	285	PRB	KBR	GE 7FA (1)	0.0149	Clean fuel	N/A
Taylorville Energy Center (Erora Gp)	IL	Final permit	Jun 2007	677	Illinois bit	GE (Texaco)	GE 7FA (2)	0.016	Clean fuel	F/B
Lima Energy IGCC (Global Energy)	OH	Final permit	Mar 2002	530	Petcoke/coal	ConocoPhillips	GE 7FA (2)	0.035	Clean fuel	F/B
<b>Facilities Having Filed Permit Applications</b>										
Southern Ill Clean Energy Ctr (Steelhead Energy)	IL	Application	Oct 2004	544	Illinois bit	ConocoPhillips	Not available	0.00924	Clean fuel	F
Excelsior Energy - Mesaba	MN	Application	Jun 2006	531	Petcoke/coal	ConocoPhillips	SW SGT6-5000F	0.0088	Clean fuel	N/A
American Electric Power Great Bend (AEP)	OH	Application	Sep 2006	629	Eastern bit	GE (Texaco)	GE 7FB (2)	0.001	Clean fuel	F
Appalachian Power Mountaineer (AEP)	WV	Application	Sep 2006	600	Eastern bit	GE (Texaco)	GE 7FB (2)	0.001**	Clean fuel	F
Energy Northwest	WA	Application	Sep 2006	600	Petcoke/coal	ConocoPhillips	SW SGT6-5000F	0.0087	Clean fuel	F/B
Nueces IGCC Plant (Tondou)	TX	Application	Sep 2006	600	Petcoke/coal	Shell	SW 501 F (2)	0.0062	Clean fuel	F/B
							Maximum	0.035		
							Minimum	0.001		
							Average	0.011		

Notes: F = limit based on filterable (front half) PM testing.  
 F/B = limit based on filterable (front half) and condensible (back half) PM testing.  
 N/A = not applicable.

\*Based on heat input to the gasifier.

\*\*This PM limit is being proposed as LAER.

Source: ECT, 2007.

Table 5-17. PM BACT Summary of IGCC Projects—Natural Gas Firing

Facility	State	Application/ Permit	Date	Plant Output (MW)	Gasifier Fuel	Gasifier Make	Combustion Turbine	NG BACT Limit (lb/MMBtu)*	BACT Control Method	Limit Basis
<u>Operating Facilities</u>										
Wabash River	IN	Operating since 1995		262	Illinois bit	ConocoPhillips	F Class CT	Not available	Clean fuel	N/A
<u>Facilities with Final or Draft Construction Permits</u>										
OUC/Southern Stanton Unit B	FL	Final permit	Dec 2006	285	PRB	KBR	GE 7FA (1)	Not available	Clean fuel	N/A
Taylorville Energy Center (Erora Gp)	IL	Final permit	Jun 2007	677	Illinois bit	GE (Texaco)	GE 7FA (2)	0.011**	Clean fuel	F/B
Lima Energy IGCC (Global Energy)	OH	Final permit	Mar 2002	530	Petcoke/coal	ConocoPhillips	GE 7FA (2)	0.0097	Clean fuel	F
<u>Facilities Having Filed Permit Applications</u>										
Southern Ill Clean Energy Ctr (Steelhead Ene	IL	Application	Oct 2004	544	Illinois bit	ConocoPhillips	na	0.0047	Clean fuel	F
Excelsior Energy - Mesaba	MN	Application	Jun 2006	531	Petcoke/coal	ConocoPhillips	SW SGT6-5000F	0.008	Clean fuel	N/A
American Electric Power Great Bend (AEP)	OH	Application	Sep 2006	629	Eastern bit	GE (Texaco)	GE 7FB (2)	Not available	Clean fuel	F
Appalachian Power Mountaineer (AEP)	WV	Application	Sep 2006	600	Eastern bit	GE (Texaco)	GE 7FB (2)	Not available	Clean fuel	F
Energy Northwest	WA	Application	Sep 2006	600	Petcoke/coal	ConocoPhillips	SW SGT6-5000F	0.0089	Clean fuel	F/B
Nueces IGCC Plant (Tondou)	TX	Application	Sep 2006	600	Petcoke/coal	Shell	SW 501 F (2)	0.0074	Clean fuel	F/B
							Maximum	0.010		
							Minimum	0.005		
							Average	0.008		

Notes: F = limit based on filterable (front half) PM testing.  
 F/B = limit based on filterable (front half) and condensible (back half) PM testing.  
 N/A = not applicable.

\*Based on heat input to the combustion turbine.

\*\*This PM limit is being proposed as LAER.

Source: ECT, 2007.

Table 5-18. Summary of Coal-Fired Power Plant PM BACT Determinations

Plant	State	Permit Date	Unit Number	Boiler Type	Generation Capacity (MW)	Comments	BACT Limit PM/PM <sub>10</sub> (lb/MMBtu)
Springerville Generating Station (Tucson Electric Power Co)	AZ	Apr 2002	3, 4	PC	800	PM 10 (filterable), fabric filter 15-percent opacity	0.015
Plum Point Energy Station (Plum Point Energy Associates, LLC)	AR	8/20/03	1	PC	800	Fabric filter	0.018
Comanche Plant Unit 3 (Public Service Company of CO)	CO	Jul 2005	3	PC	750	PM fabric filter, 10-percent opacity	0.013
Xcel Energy	CO	Jul 2005		PC	750	PM (filterable), fabric filter 3-hour average	0.020
Indiantown Cogeneration Plant (Indiantown Cogeneration, LP)	FL	1995	1	PC	330	Fabric filter	0.018
Seminole Electric Unit 3	FL	Aug 2006	3	SCPC	750	Filterable (100-percent coal), ESP/WESP 20-percent opacity	0.015
Stanton Energy Center (MUA/OUC/FMPA)	FL	1996	2	PC	468	Fabric filter	0.018
Longleaf Energy Station (LS Power)	GA	Pending	1, 2	PC	600	Fabric filter	0.015
Holcomb Generating Station (Sand Sage Power, LLC)	KS	4/5/04	2	PC	660	Fabric filter PM, 20-percent opacity PM <sub>10</sub> : 6 test runs of 120 min each	0.012
Louisville Gas & Electric	KY	Jan 2006		SCPC	750	Pulse jet fabric filter, 20-percent opacity (0.015 lb/MMBtu filterable)	0.018
Thoroughbred Generating Station (Thoroughbred Generating Co, LLC)	KY	May 2006	1,2	PC	1,500	ESP/WESP 20-percent opacity	0.018
MidAmerican Energy Center Council Bluffs (MidAmerican Energy)	IA	6/17/03	4	SCPC	750	PM Filterable 40-percent opacity	0.018
Baldwin Expansion (Dynergy)	IL	Pending	1,2	PC	750		0.018
Dellman Unit 4 (City Water Light & Power - Springfield, IL) (Not subject to SO <sub>2</sub> or NO <sub>x</sub> BACT)	IL	Draft (Feb 2006)	4	PC	250	3-hour average	0.015
Prairie State (Prairie State Generating Co, LLC)	IL	Apr 2005	1,2	PC	1,500	ESP, 20-percent opacity	0.015
Prairie Energy Power Plant (Corn Belt Energy Corporation)	IL	12/17/02	1	PC	91	ESP, 20-percent opacity	0.020
Franklin Energy Coal Project (Illinois Energy Group)	IL	Pending	1,2	PC	680		0.020
NRG Energy (Big Cajun II) (Louisiana Generating, LLC)	LA	Aug 2005	2	SCPC	575	Fabric filter, ESP	0.015
KCP&L Latan Generating	MO	Jan 2006		PC	850	Filterable PM, 20-percent opacity	0.018
Weston Bend Generating Station (Great Plains Power Company)	MO	Nov 2001	1	PC	820		0.018
Southwest Power Station (City Utilities of Springfield)	MO	12/15/04	2	PC	275	Fabric filter	0.018
Roundup Power Project (Bull Mountain Development Co)	MT	7/21/03	1, 2	PC	780	PM (filterable)	0.012
Rocky Mountain Power (Rocky Mountain Power, Inc.)	MT	6/11/02	1	PC	113		0.012
Montana Dakota Utilities	ND	Jun 2005		PC	220	PM filterable	0.017

Table 5-18. Summary of Coal-Fired Power Plant PM BACT Determinations

Plant	State	Permit Date	Unit Number	Boiler Type	Generation Capacity (MW)	Comments	BACT Limit PM/PM <sub>10</sub> (lb/MMBtu)
Whelan Energy Center (Hastings Utilities)	NE	Mar 2004	1	PC	220	Fabric filter, ≥20-percent opacity	0.018
Nebraska City Unit 2 (Omaha Public Power District)	NE	Mar 2005	2		660	Fabric filter 3-hour average	0.018
Newmont TS Power Plant (Newmont NV Energy Investment, LLC)	NV	May 2005		PC	200	Fabric filter PM <sub>10</sub> filterable ≥20-percent opacity	0.012
Desert Rock Energy Facility (Steag Power, LLC)	NM	Pending	1, 2	PC	750	Fabric filter 24-hour average	0.01
Cottonwood Energy Center (Chaco Valley Energy, LLC)	NM	Pending	1	PC	495		0.02
Mustang Generating Station (Chaco Valley Energy, LLC)	NM	Pending	1	PC	330		0.018
Santee Cooper Cross (Not subject to SO <sub>2</sub> or NO <sub>x</sub> BACT)	SC	2/5/04	3,4	PC	660	3-hour average	0.015
Calaveras Plant Spruce Unit 2 (Not subject to SO <sub>2</sub> or NO <sub>x</sub> BACT)	TX	12/05	2	PC	750		0.022
City Public Service	TX	Sep 2005		PC	750	Fabric filter, includes condensible	0.022
Sandy Creek Energy (LS Power)	TX	Pending	1	PC	500		0.033
Intermountain Power (Intermountain Power Service Corp)	UT	10/15/04	3	PC	950	PM (filterable), fabric filter	0.013
Weston Unit 4 (Wisconsin Public Service Company)	WI	Oct 2004	1	PC	500		0.018
Elm Road Generating Station (We Energy - formerly WEPCO)	WI	1/14/04	1,2	SCPC	1,230	Fabric filter, 20-percent opacity	0.018
Public Service Corp Wausau	WI	Oct 2004		SCPC	500	PM (total), 40-percent opacity Fabric filter with condensible	0.02
Longview Power (Longview Power, LLC)	WV	3/2/04	1	PC	600	Fabric filter, 10-percent opacity PM <sub>10</sub> with condensible	0.018
WYGEN II (Black Hills Corporation)	WY	Sep 2002	1	PC	500		0.012
Black Hills (Black Hills Corporation)	WY	Jun 1999	1	PC	80		0.02
Two Elk (Two Elk Generation Partners, L.P.)	WY	May 2003	1	PC	250		0.018
						Minimum	0.010
						Maximum	0.033
						Average	0.017
						Median	0.018

Source: ECT, 2007.

### 5.6.2 AUXILIARY BOILER

The Unit 6 300-MMBtu (HHV) auxiliary boiler will be fired with pipeline-quality natural gas containing no more than 2.0 gr S/100 scf. The auxiliary boiler will also operate with a capacity factor of no more than 10 percent, which is equivalent to 876 hr/yr operation at design capacity.

The use of pipeline-quality natural gas is considered to be the only technically feasible PM/PM<sub>10</sub> control technology for the auxiliary boiler. The installation of add-on control equipment such as an ESP, fabric filter, or wet scrubber would result in excessive costs due to the low uncontrolled PM/PM<sub>10</sub> emission rates.

The exclusive use of pipeline-quality natural gas and constraints on annual operations are proposed as PM/PM<sub>10</sub> BACT for the auxiliary boiler. PM/PM<sub>10</sub> BACT proposed for the Unit 6 auxiliary boiler is summarized as follows:

- Emission Limits—Use of pipeline quality natural gas containing no more than 2.0 gr S/100 scf.
- Annual Heat Input—262,752 MMBtu/yr.
- Averaging Period—Calendar year.
- Compliance Method—Fuel consumption monitoring.

### 5.6.3 EMERGENCY DIESEL ENGINES

Polk Unit 6 will include a diesel engine-driven emergency generator rated at 1,640 kW and two diesel engine-driven firewater pumps each rated at 420 hp. Excluding emergencies, each diesel engine will operate no more than 100 hr/yr for routine testing and maintenance purposes. Total estimated PM/PM<sub>10</sub> emissions for the three diesel engines are less than 0.1 tpy.

The emergency diesel engines will be subject to the applicable emission standards of NSPS Subpart IIII for new nonroad IC engines. Subpart IIII limits PM/PM<sub>10</sub> emissions to 0.2 g/kW-hr for emergency generators purchased in 2007 or later. For firewater pumps, Subpart IIII also limits PM/PM<sub>10</sub> emissions, but the emission limits (Tier II or Tier III)



are dependent upon the model year in which the pump was manufactured. Emergency diesel engines purchased for Unit 6 will comply with the applicable emission standards of NSPS Subpart IIII.

Compliance with the stringent NSPS Subpart IIII emission standards and limited annual operating hours is proposed as PM/PM<sub>10</sub> BACT for the Unit 6 emergency generator and firewater pump diesel engines. PM/PM<sub>10</sub> BACT proposed for the Unit 6 emergency diesel engines is summarized as follows:

- Emission Limit—Applicable standards of NSPS Subpart IIII.
- Averaging Period—Per NSPS Subpart IIII.
- Compliance Method—Engine manufacturer certification in accordance with NSPS Subpart IIII.
- Annual Operating Hours—100 hr/yr/engine (excluding emergencies), per engine.
- Averaging Period—Calendar year.
- Compliance Method—Monitoring of operating hours using engine run-time meters.

#### **5.6.4 COOLING TOWER**

Cooling towers can employ either dry or wet cooling technologies. The heat dissipated from the Unit 6 CT/HRSGs can be cooled either by a source of air or water. An air-cooled condenser (ACC) uses air as the media for heat exchange, while a wet cooling tower employs water. Both of these technologies have been successfully used at recently constructed power plants.

##### **5.6.4.1 Dry Cooling**

An ACC is made up of a number of modules that are arranged in parallel lines. Within each module, there are many fin tube bundles. An axial flow, forced-draft fan is located within each module, and pushes the cooling air across the heat exchange area of the fin tubes. An ACC includes a supporting structure that would be substantially higher than a typical wet mechanical-draft cooling tower.

ACC technology would not maintain design plant output during the hot humid summers in Central Florida during periods of peak demand. The efficiency of an ACC is directly related to the ambient air temperature. Other disadvantages of ACC are potential scaling and corrosion from ambient salt concentration and high temperatures, high consumption of electricity for fan operation, significant source of noise, visual impacts, and high maintenance costs.

The clear advantage of an ACC is the significant reduction in water use and negligible PM/PM<sub>10</sub> emissions. Therefore, ACCs are closely evaluated for facilities located in areas which lack sufficient water resources. Unit 6 will use the existing cooling water reservoir as its water source and is located in a climate not conducive to using ACC technology.

#### **5.6.4.2 Wet Cooling**

Operation of conventional wet mechanical draft cooling tower operations will result in emissions of PM/PM<sub>10</sub>. Unit 6 will include a 10-cell cooling tower using makeup water from the existing PPS cooling water reservoir. Because of direct contact between the cooling water and ambient air, a small portion of the recirculating cooling water is entrained in the air stream and discharged from the cooling tower as drift droplets. These water droplets contain the same concentration of dissolved solids as found in the recirculating cooling water. Large water droplets quickly settle out of the cooling tower exhaust stream and deposit near the tower. The remaining smaller water droplets may evaporate prior to being deposited in the area surrounding the cooling tower. These evaporated droplets represent potential PM/PM<sub>10</sub> emissions because of the fine PM/PM<sub>10</sub> formed by crystallization of the dissolved solids contained in the droplet.

#### **5.6.4.3 Available PM/PM<sub>10</sub> Control Technologies**

Due to the technical issues associated with dry cooling, dry cooling tower technology is not considered technically feasible. Technical issues with the dry cooling technology include the inability to maintain plant design performance during hot humid periods, potential scaling and corrosion from ambient salt concentration and high temperatures, high

consumption of electricity for fan operation, significant source of noise, visual impacts, and high maintenance costs.

The only feasible technology for controlling PM/PM<sub>10</sub> from wet cooling towers is the use of drift eliminators. Drift eliminators rely on inertial separation caused by airflow direction changes to remove water droplets from the air stream leaving the tower. The water droplets are returned to the cooling tower. Drift eliminator configurations include herringbone (blade-type), wave-form, and cellular (honeycomb) designs. Drift eliminator materials of construction include ceramics; fiber-reinforced cement; metal; plastic; and wood fabricated into closely spaced slats, sheets, honeycomb assemblies, or tiles.

#### **5.6.4.4 Proposed PM/PM<sub>10</sub> BACT**

PM/PM<sub>10</sub> emissions from the Unit 6 cooling tower will be controlled using high efficiency drift eliminators. The cooling tower will achieve a drift loss rate of no more than 0.0005 percent of the cooling tower recirculating water flow. This cooling tower drift loss rate is consistent with recent FDEP BACT determinations (i.e., the Florida Power & Light Company [FPL] Turkey Point Unit 5 and West County Energy Center projects). PM/PM<sub>10</sub> BACT proposed for the Unit 6 cooling tower is summarized as follows:

- Emission Limit—Use of high efficiency drift eliminators with a drift loss rate of no more than 0.0005 percent.
- Compliance Method—Cooling tower manufacturer certification.

#### **5.6.5 MATERIAL HANDLING**

The Unit 6 material handling PM/PM<sub>10</sub> emission sources include feedstock (coal, petcoke, and biomass) unloading, transfer, conveying, and storage. Similar storage and transfer operations will be needed for the gasifier slag, but because of the nature of this material, PM/PM<sub>10</sub> emissions are expected to be negligible. Also, haul trucks for moving material on and off the site will create emissions. Both fugitive and nonfugitive PM/PM<sub>10</sub> emissions will be generated. Fugitive emissions are emissions that cannot reasonably pass through a stack, chimney, vent, or other functionally equivalent opening. In contrast, nonfugitive emissions are emissions that can reasonably be collected and subsequently

passed through a stack, chimney, vent, or other functionally equivalent opening. Fugitive and nonfugitive PM/PM<sub>10</sub> emissions from material handling will be generated from three general source categories: transfer points, storage piles, and roads.

#### **5.6.5.1 Available PM/PM<sub>10</sub> Control Technologies**

##### **Transfer Points**

Transfer points include truck and rail loading/unloading, conveyor-to-conveyor drops, material transfers from reclaim hoppers to conveyors, and transfers from conveyors to storage areas. Particulate emissions will be generated as material drops onto a conveyor or storage pile. The potential to generate particulate emissions at a transfer point is a function of the rate at which the material flows through the transfer point, exposure to wind, and the material's particle size and moisture content. Potential emissions from a transfer point can be reduced by decreasing the speed at which the material is transferred, decreasing the wind speed to which the material is exposed, or increasing the aggregate's moisture content by watering or chemical wetting agents. Transfer point emissions may be further reduced by enclosing the transfer operations within a structure, and exhausting the particulate-laden air through a particulate control device (e.g., fabric filter).

##### **Storage Piles**

Fugitive PM/PM<sub>10</sub> emissions associated with storage piles include dust emissions produced by adding/removing material from the pile, grooming the pile, and from wind erosion. A combination of material drop controls (e.g., telescopic chutes), compaction, and dust suppression sprays (e.g., wetting) can be used to minimize fugitive emission from the material handling and storage piles.

##### **Roads**

Vehicular traffic on paved and unpaved roads will generate fugitive PM/PM<sub>10</sub> emissions. Particulate emissions from roads can be controlled by sweeping, applying water as necessary, and limiting vehicle speeds. Since the majority of vehicular traffic will occur on paved roadways, PM/PM<sub>10</sub> emissions will be insignificant.

### **5.6.5.2 Proposed PM/PM<sub>10</sub> BACT**

A combination of good operating practices and fabric filters are proposed as PM/PM<sub>10</sub> BACT for the Unit 6 material handling emission sources. Specific PM/PM<sub>10</sub> control measures proposed for the Unit 6 material handling systems are as follows:

- Transfers Points—To the extent practical and appropriate, material handling transfer points will be enclosed and vented to fabric filters with a design outlet PM/PM<sub>10</sub> concentration of no more than 0.01 gr/dscf. Where complete enclosure is not practical, partial enclosure and/or wet dust suppression systems using water sprays or a chemical wetting agents will be employed.
- Storage Piles—Water or chemical dust suppression will be applied to the active storage piles. Surface crusting agents will be applied to the inactive storage piles to minimize PM/PM<sub>10</sub> emissions due to wind erosion.
- Roads—The primary plant roadways will be paved. These roads will be watered or swept, as necessary, to control fugitive PM/PM<sub>10</sub> emissions. Traffic on unpaved roads will be kept to the minimum required for plant operations and will be watered, as necessary, to control fugitive PM/PM<sub>10</sub> emissions.

## **5.7 SUMMARY OF PROPOSED BACT**

Table 5-19 provides a summary of the BACT proposed for Polk Unit 6, including the emission limit, averaging period, and compliance method.

Table 5-19. Summary of Proposed BACT

Emission Unit	Pollutant	Averaging Period	BACT Emission Limit	Compliance Method
CT/HRSGs (syngas firing) (each CT/HRSG unit)	NO <sub>x</sub>	30-Day rolling	99 lb/hr	CEMS
	SO <sub>2</sub>	30-Day rolling	52 lb/hr	CEMS
	H <sub>2</sub> SO <sub>4</sub>	Stack test duration	12.8 lb/hr	EPA reference methods
	CO	24-Hour Rolling	93 lb/hr	CEMS
	PM <sub>10</sub> (total)	Stack test duration	39 lb/hr	EPA reference methods
CT/HRSGs (natural gas firing) (each CT/HRSG unit)	NO <sub>x</sub>	30-Day rolling	33 lb/hr	CEMS
	SO <sub>2</sub>	N/A	Pipeline quality natural gas	Fuel sampling
	H <sub>2</sub> SO <sub>4</sub>	N/A	Pipeline quality natural gas	Fuel sampling
	CO	24-Hour Rolling	81 lb/hr	CEMS
	PM <sub>10</sub> (total)	Not applicable	Pipeline quality natural gas	Fuel sampling
H <sub>2</sub> SO <sub>4</sub> Plant	SO <sub>2</sub>	Stack test duration	36.7 lb/hr	EPA reference methods
	H <sub>2</sub> SO <sub>4</sub>	Stack test duration	3.7 lb/hr	EPA reference methods
Auxiliary boiler	NO <sub>x</sub>	Stack test duration	10.8 lb/hr	EPA reference methods
	SO <sub>2</sub>	Not applicable	Pipeline quality natural gas	Fuel sampling
	H <sub>2</sub> SO <sub>4</sub>	Not applicable	Pipeline quality natural gas	Fuel sampling
	CO	Stack test duration	10.8 lb/hr	EPA reference methods
	PM/PM <sub>10</sub>	Not applicable	Pipeline quality natural gas	Fuel sampling
Emergency diesel engines	NO <sub>x</sub>	Not applicable	Applicable NSPS Subpart III Standard	Engine manufacturer certification
	SO <sub>2</sub>	Not applicable	USLD fuel oil	Fuel supplier certifications
	H <sub>2</sub> SO <sub>4</sub>	Not applicable	USLD fuel oil	Fuel supplier certifications
	CO	Not applicable	Applicable NSPS Subpart III Standard	Engine manufacturer certification
	PM/PM <sub>10</sub>	Not applicable	Applicable NSPS Subpart III Standard	Engine manufacturer certification

5-79

Table 5-19. Summary of Proposed BACT

Emission Unit	Pollutant	Averaging Period	BACT Emission Limit	Compliance Method
Cooling tower	PM/PM <sub>10</sub>	Not applicable	Drift eliminators Drift loss rate of 0.0005 percent	Cooling tower manufacturer certification
Material handling sources transfer points	PM/PM <sub>10</sub>	Not applicable 6-minute	Enclosures, partial enclosures, wet suppression, application of chemical wetting agents 5 percent opacity	Good operating practices EPA Reference 9
Storage silos	PM/PM <sub>10</sub>	6-minute	5 percent opacity	EPA Reference 9
Storage piles	PM/PM <sub>10</sub>	Not applicable	Enclosures, partial enclosures, wet suppression, application of chemical wetting agents	Good operating practices
Plant roads	PM/PM <sub>10</sub>	Not applicable	Paving of primary roadways, watering and/or sweeping	Good operating practices

Source: ECT, 2007.

## **6.0 AIR QUALITY IMPACT ANALYSIS METHODOLOGY**

### **6.1 GENERAL APPROACH**

As previously noted in Section 3.1, Unit 6 is located in an area that is designated attainment or unclassifiable for all criteria pollutants. All areas of Florida, with the exception of four PSD Class I areas, are designated as PSD Class II areas. The Florida PSD Class I areas include the Everglades NP and the Chassahowitzka, St. Marks, and Bradwell Bay NWAs. Accordingly, PPS and vicinity are classified as a PSD Class II area. This section focuses on the methodology used to determine Project air quality impacts with respect to the PSD Class II increments and NAAQS. Unit 6 air quality impacts with respect to the PSD Class I areas are addressed in Section 10.0.

The approach to assessing air quality impacts for a new or modified emission source generally begins by determining the impacts of only the proposed Project. If Project impacts are below the PSD SILs, then no further analysis is required. The PSD Class II SILs were previously presented in Table 3-4. If the impacts of a proposed Project are found to exceed a particular PSD SIL, further analysis considering other existing sources and background pollutant concentrations is required for that SIL.

The approach used to analyze the potential impacts of Unit 6, as described in detail in the following subsections, was developed in accordance with accepted practice. Guidance contained in EPA manuals and user's guides was sought and followed. In addition, an Air Quality Impact Analysis Modeling Protocol was submitted to FDEP and EPA Region 4 in June 2007 for review and comments. The air quality impact analyses conducted for Unit 6 incorporates the comments and suggestions received from FDEP and EPA on the modeling protocol.

### **6.2 POLLUTANTS EVALUATED**

Based on an evaluation of anticipated worst-case annual operating scenarios, Unit 6 will have the potential to emit 925 tpy of NO<sub>x</sub>, 910 tpy of CO, 368 tpy of PM<sub>10</sub>, 670 tpy of SO<sub>2</sub>, 38 tpy of VOCs, and 123 tpy of H<sub>2</sub>SO<sub>4</sub> mist. Table 3-2 previously provided estimated potential annual emission rates for Unit 6. As shown in that table, potential emis-



sions of NO<sub>x</sub>, CO, PM, PM<sub>10</sub>, SO<sub>2</sub>, and H<sub>2</sub>SO<sub>4</sub> mist are each projected to exceed the applicable PSD significant emission rate (SER) threshold. Potential emissions from Unit 6 are below the applicable PSD SER levels for all other PSD regulated pollutants. Accordingly, Unit 6 is subject to the PSD NSR air quality impact analysis requirements of Rule 62-212.400(5)(d), F.A.C., for NO<sub>x</sub>, CO, PM, PM<sub>10</sub>, SO<sub>2</sub>, and H<sub>2</sub>SO<sub>4</sub> mist.

Assessment of Unit 6 air quality impacts for H<sub>2</sub>SO<sub>4</sub> mist was not conducted since there are no PSD increments or AAQS for this constituent. In accordance with current EPA policy, PM<sub>10</sub> was used as a surrogate with respect to PM<sub>2.5</sub> impacts.

### **6.3 MODEL SELECTION AND USE**

Air quality models are applied at two levels: screening and refined. At the screening level, models provide conservative estimates of impacts to determine whether more detailed modeling is required. Screening modeling can also be used to identify worst-case operating scenarios for subsequent refined modeling analysis. The refined level consists of techniques that provide more advanced technical treatment of atmospheric processes. Refined modeling requires more detailed and precise input data, but also provides improved estimates of source impacts. For the Unit 6 air quality analyses, the current version of the refined AMS/EPA Regulatory Model (AERMOD) modeling system (Version 07026—January 26, 2007), together with 5 years of hour-by-hour National Weather Service meteorology, was used to obtain predictions of both short-term periods (i.e., periods equal to or less than 24 hours) and annual average air quality impacts.

Regulatory agency recommended procedures for conducting air quality impact assessments are contained in the EPA's GAQM. In the November 9, 2005, FR, EPA approved use of AERMOD as a GAQM Appendix A *preferred* model effective December 9, 2005. AERMOD is recommended for use in a wide range of regulatory applications, including both simple and complex terrain. The AERMOD modeling system consists of meteorological and terrain preprocessing programs (AERMET and AERMAP, respectively), and the AERMOD dispersion model.

#### **6.4 MODEL OPTIONS**

Procedures applicable to the AERMOD modeling system specified in the latest version of the User's Guide for the AMS/EPA Regulatory Model—AERMOD (September 2004) and EPA's November 9, 2005, revisions to the GAQM were followed. In particular, the AERMOD control pathway MODELOPT keyword parameters DFAULT and CONC were selected. Selection of the parameter DFAULT, which specifies use of the regulatory default options, is recommended by the GAQM. The CONC option specifies the calculation of concentrations. Unit 6 will be located in rural Polk County. Accordingly, AERMOD options regarding pertinent to urban areas including increased surface heating (URBANOPT keyword) and pollutant exponential decay (HALFLIFE and DCAYCOEF keywords) were not employed. In addition, the option to use flagpole receptors (FLAGPOLE keyword) was not selected.

As previously mentioned, the AERMOD modeling system was used to determine annual average impact predictions, in addition to short-term averages, by using the PERIOD parameter for the AVERTIME keyword.

#### **6.5 NO<sub>2</sub> AMBIENT IMPACT ANALYSIS**

For annual NO<sub>2</sub> impacts, the tiered screening approach described in the GAQM, Section 6.2.3, was used. Tier 1 of this screening procedure assumes complete conversion of NO<sub>x</sub> to NO<sub>2</sub>. Tier 2 applies an empirically derived NO<sub>2</sub>/NO<sub>x</sub> ratio of 0.75 to the Tier 1 results.

#### **6.6 TERRAIN CONSIDERATION**

The GAQM defines *flat* terrain as terrain equal to the elevation of the stack base, *simple* terrain as terrain lower than the height of the stack top, and *complex* terrain as terrain exceeding the height of the stack being modeled.

Site elevation for the PPS is approximately 140 feet above mean sea level (ft-msl). The Unit 6 CT/HRSG stacks will each have a height of 175 ft above grade elevation. The Unit 6 sulfuric acid plant and cooling tower will have stack heights of 275 and 42 ft above grade elevation, respectively. Accordingly, terrain elevations above approximately

315 ft-msl (for the CT/HRSG units), 415 ft-msl (for the sulfuric acid plant), and 182 ft-msl (for the cooling tower) would be classified as complex terrain. U.S. Geological Survey (USGS) 7.5-minute series topographic maps were examined for terrain features in the Unit 6 impact area. The topography in the vicinity of the PPS is essentially flat with maximum elevations well below the levels that would constitute complex terrain. Based on this examination, terrain in the vicinity of the PPS is classified as simple terrain for all Unit 6 stacks.

In accordance with the GAQM recommendations for AERMOD, each modeled receptor was assigned a terrain elevation based on USGS 7.5-minute digital elevation model (DEM) data and the AERMAP (Version 06341—December 7, 2006) terrain preprocessing program. AERMAP was used in accordance with the latest version of the *User's Guide for the AERMOD Terrain Preprocessor (AERMAP)*, addenda to the User's Guide, and EPA's GAQM.

## **6.7 BUILDING WAKE EFFECTS**

The CAA Amendments require the degree of emission limitation required for control of any pollutant not be affected by a stack height that exceeds good engineering practice (GEP) or any other dispersion technique. On July 8, 1985, EPA promulgated final stack height regulations (40 CFR 51). GEP stack heights for the Unit 6 emission sources will comply with the EPA promulgated final stack height regulations (40 CFR 51). GEP stack height is defined as the highest of 65 meters, or a height established by applying the formula:

$$H_g = H + 1.5 L$$

where:  $H_g$  = GEP stack height.

$H$  = height of the structure or nearby structure.

$L$  = lesser dimension (height or projected width) of the nearby structure.

*Nearby* is defined as a distance up to five times the lesser of the height or width dimension of a structure or terrain feature, but not greater than 800 meters. While GEP stack height regulations require that stack height used in modeling for determining compliance

with NAAQS and PSD increments not exceed the GEP stack height, the actual stack height may be greater. Guidelines for determining GEP stack height have been issued by EPA (1985).

Heights proposed for the Unit 6 CT/HRSG stacks (175 ft above grade level) and sulfuric acid plant stack (275 ft above grade level) are less than the calculated GEP stack height of 625 ft for these Unit 6 emission points. The dominant Unit 6 structure influencing downwash for the Unit 6 CT/HRSG and sulfuric acid plant stacks is the gasifier structure which will have a height of 280 ft. Since the stack heights of the Unit 6 emission sources will comply with the EPA promulgated final stack height regulations, the proposed Unit 6 stack heights were used in the modeling analyses.

While the GEP stack height rules address the maximum stack height that can be employed in a dispersion model analysis, stacks having heights lower than GEP stack height can potentially result in higher downwind concentrations due to building downwash effects. AERMOD evaluates the effects of building downwash based on the Plume Rise Model Enhancements (PRIME) building downwash algorithms. For the Unit 6 ambient impact analysis, the complex downwash analysis implemented by AERMOD was performed using the current version of EPA's Building Profile Input Program for PRIME (BPIPPRM—Version 04274 [September 30, 2004]). The EPA BPIP program was used to determine the area of influence for each building, whether a particular stack is subject to building downwash, the area of influence for directionally dependent building downwash, and finally to generate the specific building dimension data required by the model. BPIP output consists of an array of 36 direction-specific (10 degrees [°] to 360°) building heights (BUILDHGT keyword), lengths (BUILDLLEN keyword), widths (BUILDWID keyword), and along-flow (XBADJ keyword) and across-flow (YBADJ keyword) distances for each stack suitable for use as input to AERMOD.

Dimensions of the Unit 6 buildings/structures evaluated for wake effects are provided in Table 6-1. The building/structure dimensions were determined from engineering layouts and specifications. The buildings are shown in three-dimension in Figure 6-1.

Table 6-1. Dimensions of Unit 6 Major Buildings and Structures

Building/Structure	Height (ft)	Length (ft)	Width (ft)
Active coal pile	65	350	175
Inactive coal pile (north)	110	900	430
Inactive coal pile (south)	110	700	640
Emergency stack-out pile*	60	200	
Fuel blending silos	60	160	35
Coal grinding/slurry building	120	240	125
Air separation unit cold box*	175	35	
Slag stack-out area	20	150	120
Auxiliary boiler	50	150	75
Gasifiers	280	165	165
HRSG 1 and 2 trains (each)	100	98	32
Steam turbine generator	94	200	84
Cooling tower	42	250	100

\*Length dimension represents structure diameter.

Sources: Bechtel, 2007.  
ECT, 2007.



© Bechtel Corporation 2007. All rights reserved.

FIGURE 6-1.  
UNIT 6 THREE-DIMENSIONAL VIEW

Source: Bechtel Corporation, 2007.



## **6.8 RECEPTOR GRIDS**

Receptors were placed at locations considered to be ambient air, which is defined as “that portion of the atmosphere, external to buildings, to which the general public has access.” The entire perimeter of the PPS plant site is fenced. Therefore, the nearest locations of general public access are at the facility fence lines. Consistent with GAQM and FDEP recommendations, the Unit 6 ambient impact analysis utilized the following receptor grids:

- Fence Line Receptors: Receptors placed on the site fence line spaced 50 meters apart.
- Near-Field Cartesian Receptors: Receptors at 100-meter spacing starting at 100 meters from the fence line receptors and extending to 3,000 meters from the center of the PPS site.
- Mid-Field Cartesian Receptors: Receptors at 250-meter spacing starting at 3,250 meters and extending to 6,000 meters from the center of the PPS site.
- Far-Field Cartesian Receptors: Receptors at 500-meter spacing starting at 6,500 meters and extending to 15,000 meters from the center of the PPS site.

As necessary, the receptor grids used for the ambient impact analysis were refined following initial modeling to ensure that the highest ambient impacts for each pollutant and averaging period have been identified utilizing a receptor spacing of no more than 100 meters.

Figure 6-2 provides a graphical representation of the fence line receptors. A graphical representation of the near- and mid-field receptor grids is shown on Figure 6-3. A depiction of the far-field receptor grid is provided on Figure 6-4.

## **6.9 METEOROLOGICAL DATA**

The AERMET meteorological preprocessing program creates two files that are used by AERMOD (i.e., surface and profile files). The surface file contains boundary layer parameters including friction velocity, Monin-Obukhov length, convective velocity scale, temperature scale, convectively-generated boundary layer (CBL) height, stable boundary

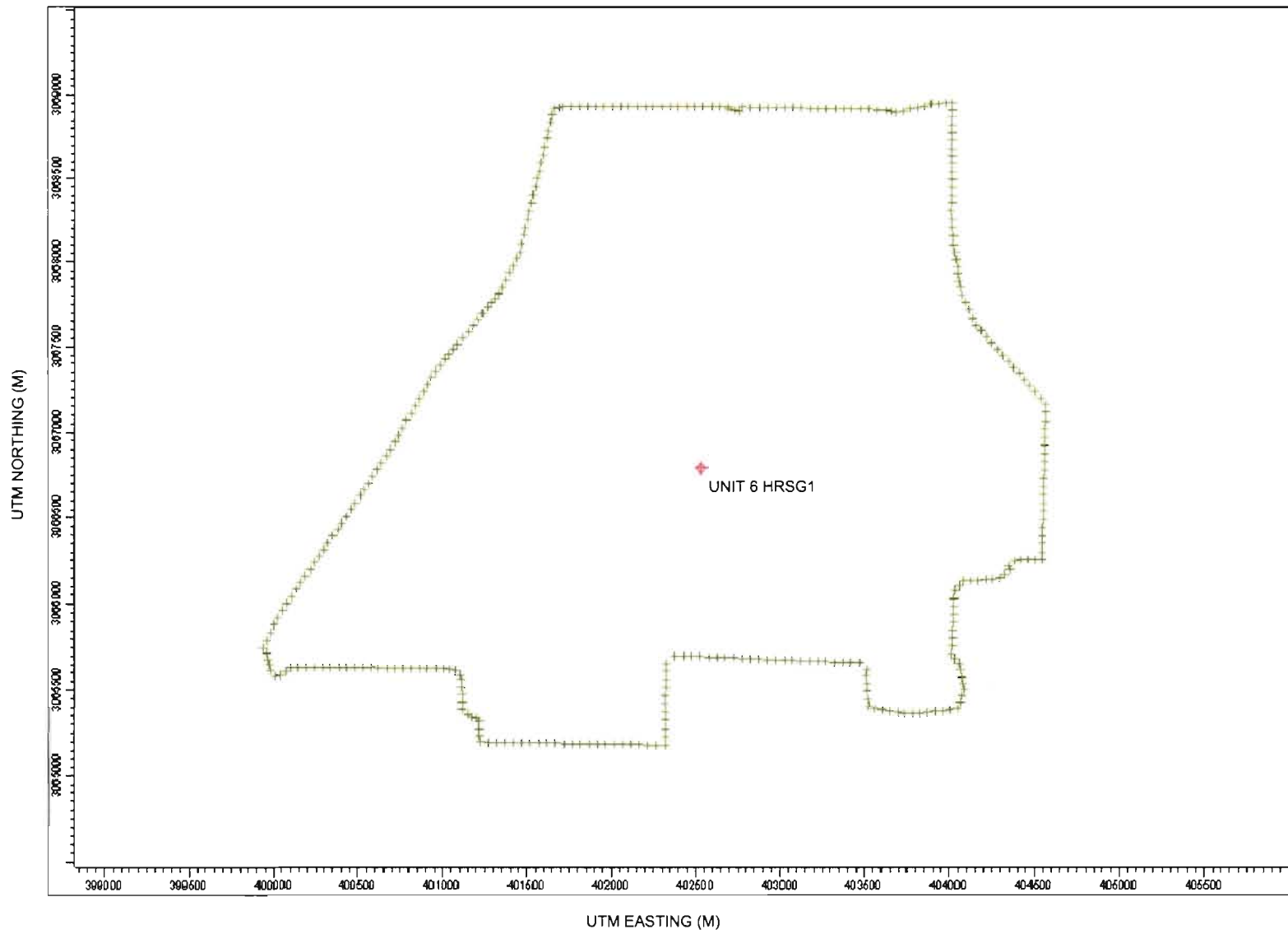

6-9

FIGURE 6.2.  
UNIT 6 FENCELINE RECEPTORS

Source: ECT, 2007.





01-9

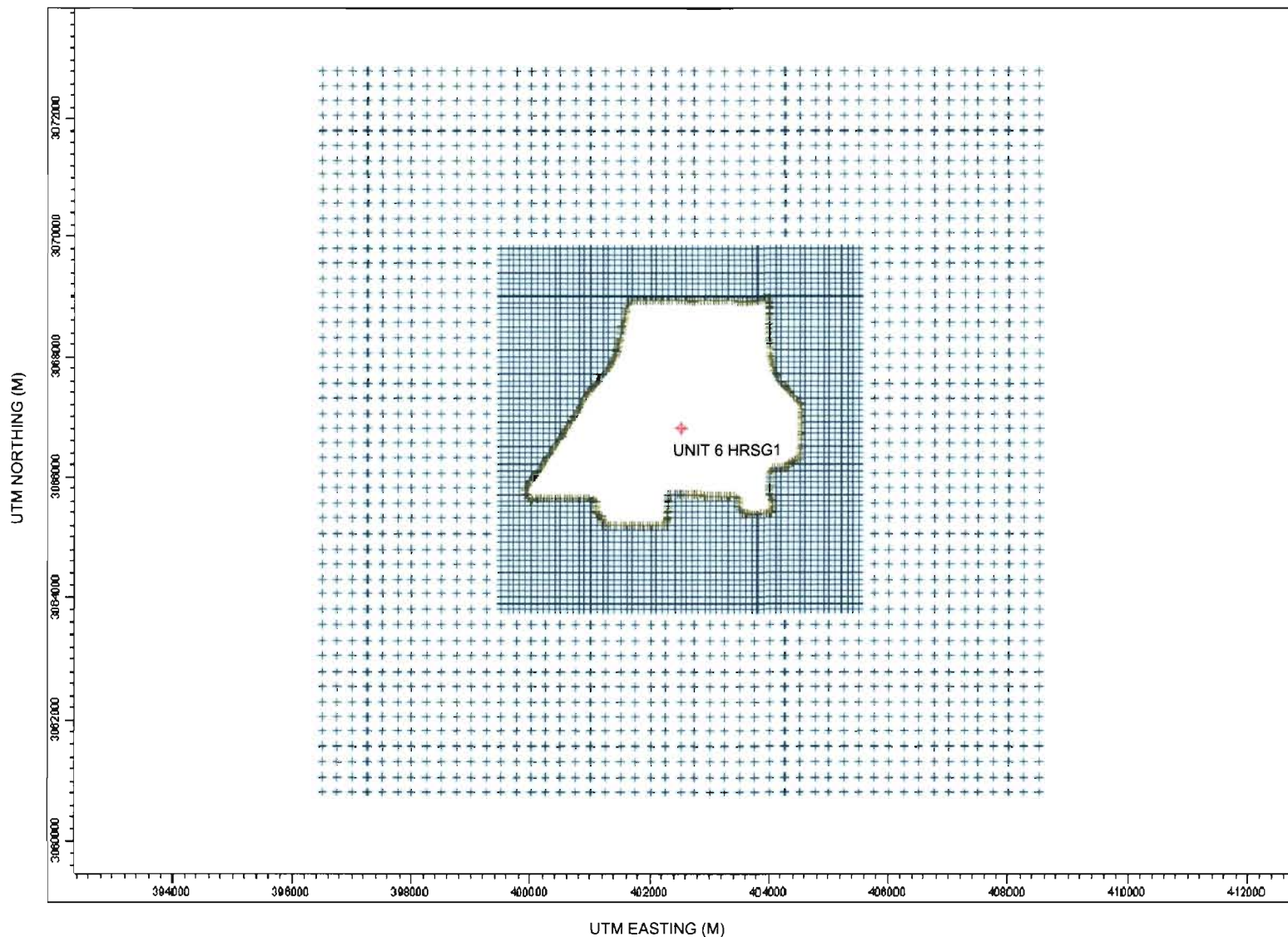

FIGURE 6.3.  
UNIT 6 NEAR- AND MID-FIELD RECEPTORS

Source: ECT, 2007.



11-9

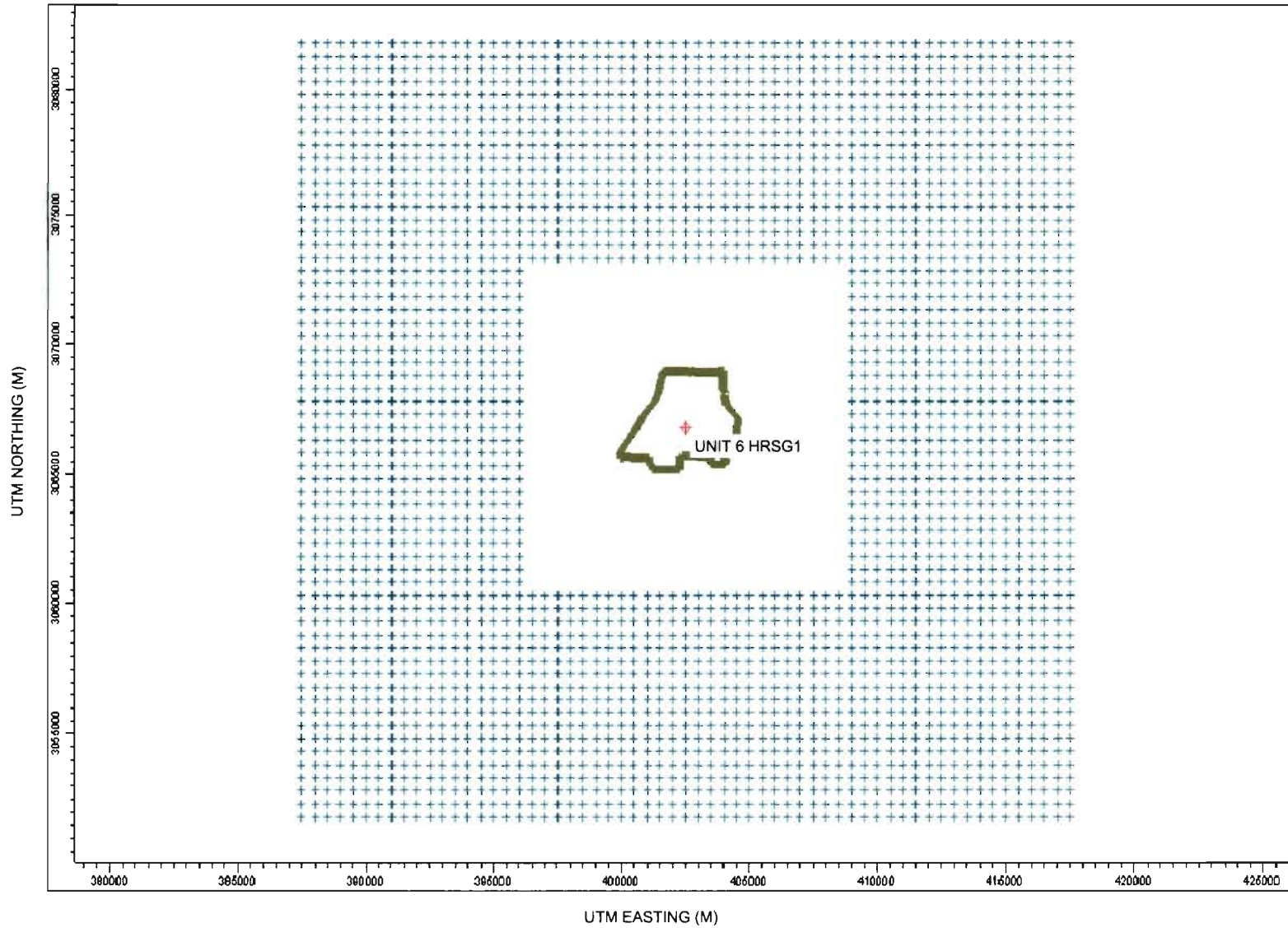

FIGURE 6.4.  
UNIT 6 FAR-FIELD RECEPTORS

Source: ECT, 2007.



layer (SBL) height, and surface heat flux. The profile file contains multi-level data of windspeed, wind direction, and temperature.

AERMET calculates the hourly boundary layer parameters for use by AERMOD, including friction velocity, Monin-Obukhov length, convective velocity scale, temperature scale, CBL and SBL heights, and surface heat flux. In addition, AERMET passes all observed meteorological parameters to AERMOD including wind direction and speed (at multiple heights, if available), temperature, and if available, measured turbulence. AERMOD uses this information to calculate concentrations in a manner that accounts for a dispersion rate that is a continuous function of meteorology.

Review of the nearest meteorological surface stations with readily available meteorological data required for AERMET identified two potential stations, Tampa International Airport (TPA) and Orlando International Airport (MCO). TPA and MCO are located approximately 38 miles to the west-northwest and 64 miles to the north-northeast of PPS, respectively. Based on FDEP guidance and similarities in wind roses and surrounding surface roughness lengths between the PPS and the MCO meteorological station, 5 years (1999 to 2003) of MCO surface and TPA upper air meteorological data provided by FDEP were used for the PPS Unit 6 air quality impact analysis.

The nearest NCDC meteorological station that records hourly data is located approximately 25 miles northeast of the PPS at Winter Haven Gilbert Airport (WHA). WHA does not provide meteorological data suitable for dispersion modeling purposes, but can serve as a source of windspeed and direction. Figure 6-5 provides a wind rose showing 2003/2004 annual average wind data for WHA. Since WHA is near to PPS and both sites are located similar distances (WHA 66 miles and PPS 47 miles) from the Gulf of Mexico, the general wind patterns for the two sites should be similar.

The WHA wind patterns were compared to wind patterns from the TPA and MCO meteorological stations. These two stations have readily available meteorological data that were previously processed by FDEP. Annual wind roses generated for the TPA and MCO stations for 2003/2004 are provided in Figures 6-6 and 6-7, respectively. In reviewing the

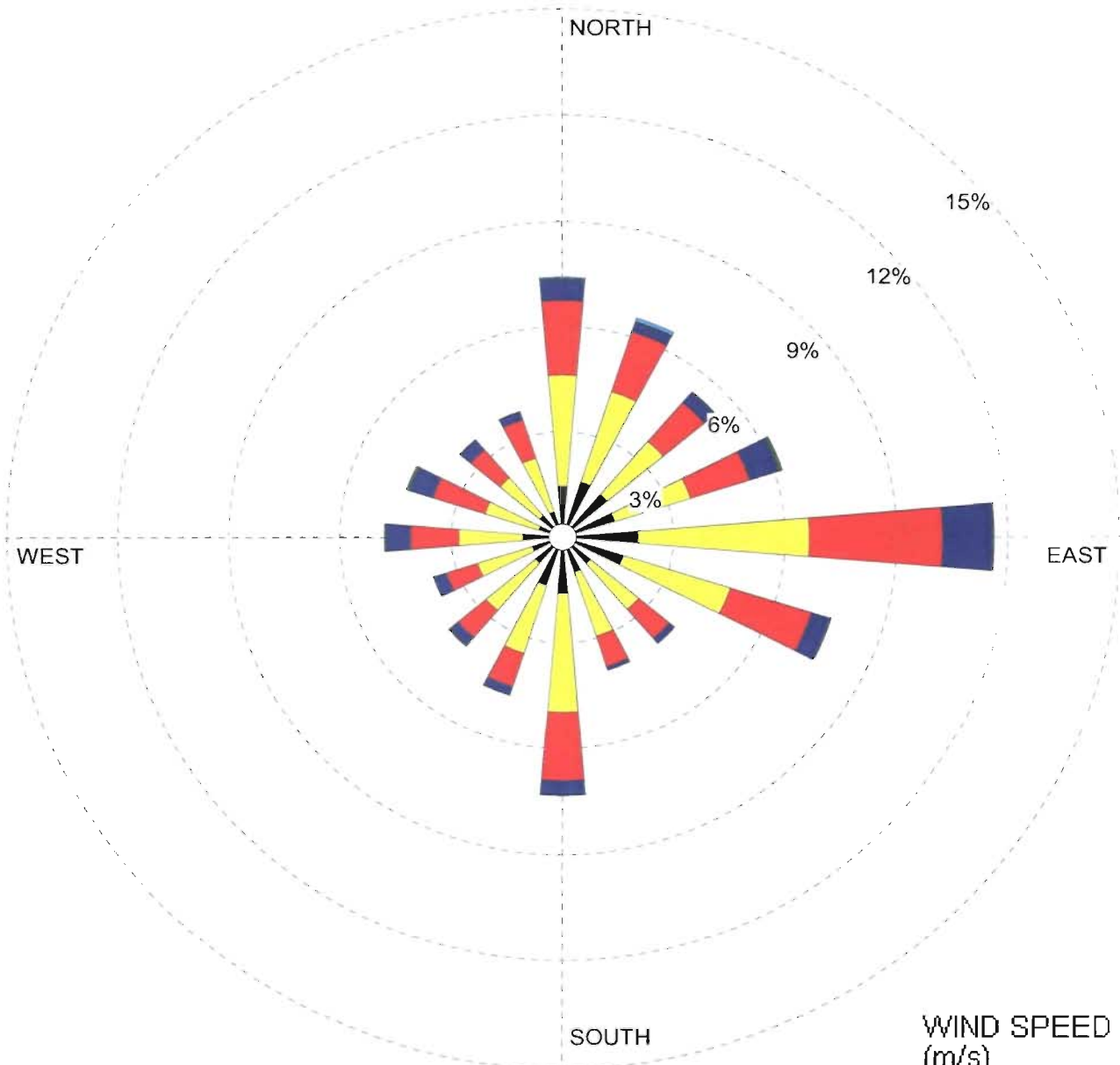

FIGURE 6-5.

WIND ROSE FOR WINTER HAVEN GILBERT AIRPORT (2003-2004)

Source: ECT, 2007. NCDC, 2007.



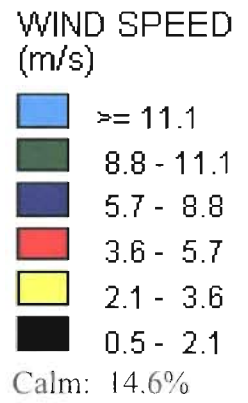
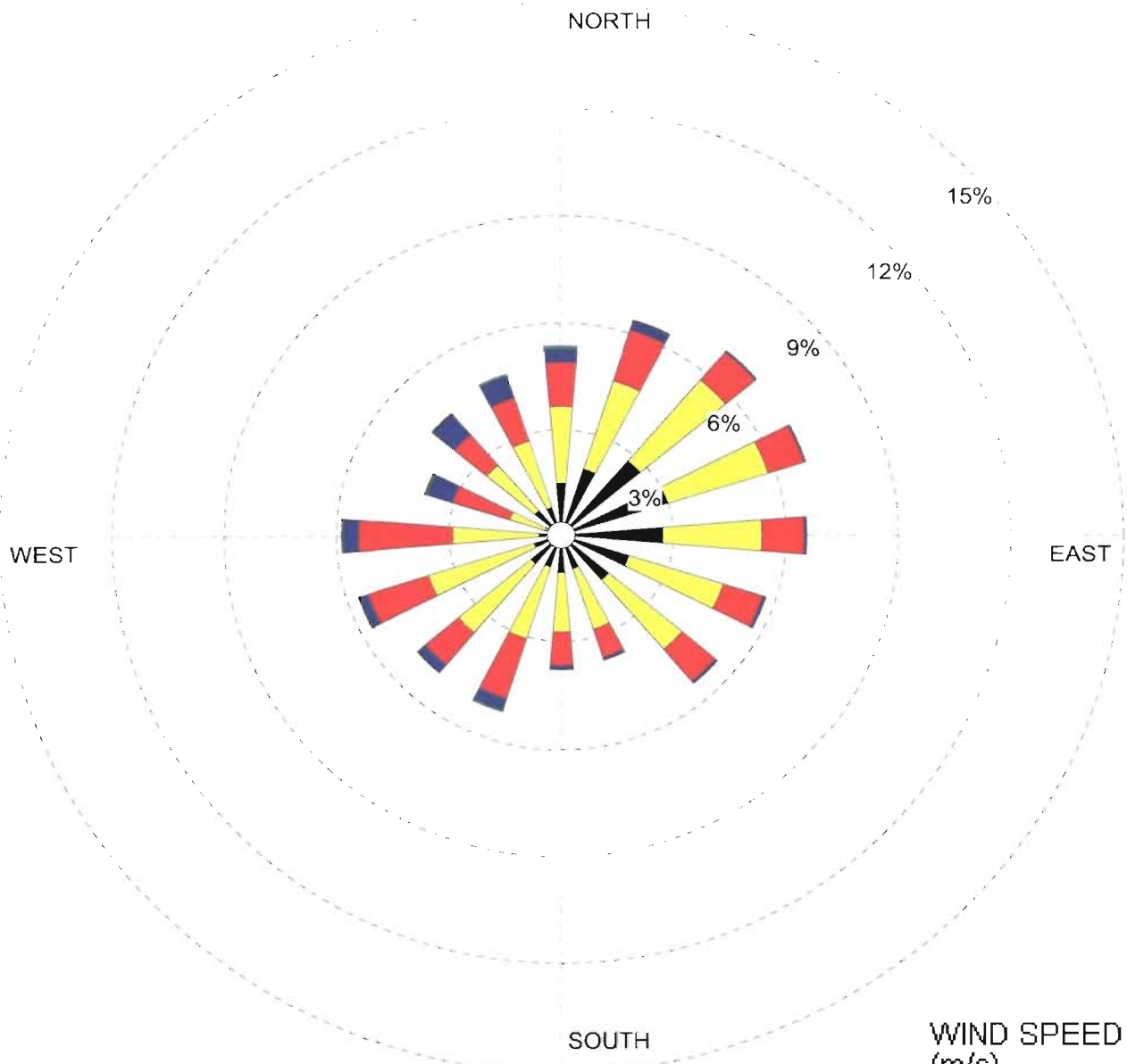

FIGURE 6-6.

WIND ROSE FOR TAMPA INTL AIRPORT (2003-2004)

Source: ECT, 2007. NCDC, 2007.



wind roses in Figures 6-4 through 6-6, similar wind directions can be identified between the WHA and MCO stations. The TPA wind rose does not show a similar relationship. Additional similarities were found in the WHA and MCO site windspeeds, including the recorded percent calms. The TPA wind rose shows differing windspeeds not consistent with either WHA or MCO. Therefore, it is concluded that data collected from MCO is more representative of both the WHA and PPS sites than data collected at TPA.

To further determine whether MCO meteorological data is reasonably representative of conditions occurring at the PPS, an analysis of the surface characteristic surrounding PPS, TPA, and MCO was performed. Surface characteristics in the vicinity of a site are important in determining the boundary layer parameter estimates calculated by AERMET. Obstacles to the wind flow, amount of moisture at the surface, and reflectivity of the surface all affect the boundary layer parameter estimates. The AERMET keywords `FREQ_SECT`, `SECTOR`, and `SITE_CHAR` are used to define the surface albedo, Bowen ratio, and surface roughness length ( $z_0$ ).

Albedo is the fraction of total incident solar radiation reflected by the surface back to space without absorption. The daytime Bowen ratio is an indicator of surface moisture and is used for determining planetary boundary layer parameters for convective conditions. The surface roughness length is related to the height of obstacles to the wind flow and represents the height at which the mean horizontal windspeed is zero. Of these three parameters surface roughness length is the most sensitive and therefore, highlighted in this surface characteristic analysis.

To perform the surface characteristic analysis, guidance contained in Tables 4-1 through 4-3 of the AERMET User's Guide () was used to define the seasonal values of surface albedo, daytime Bowen ratio, and surface roughness length. Land use and aerial maps showing a 3-km area surrounding the sites were used to classify land use categories for 12 sectors around the sites with each sector being equivalent to 30°. Details of the land use categories and surface characteristic parameters are provided in Appendix D.

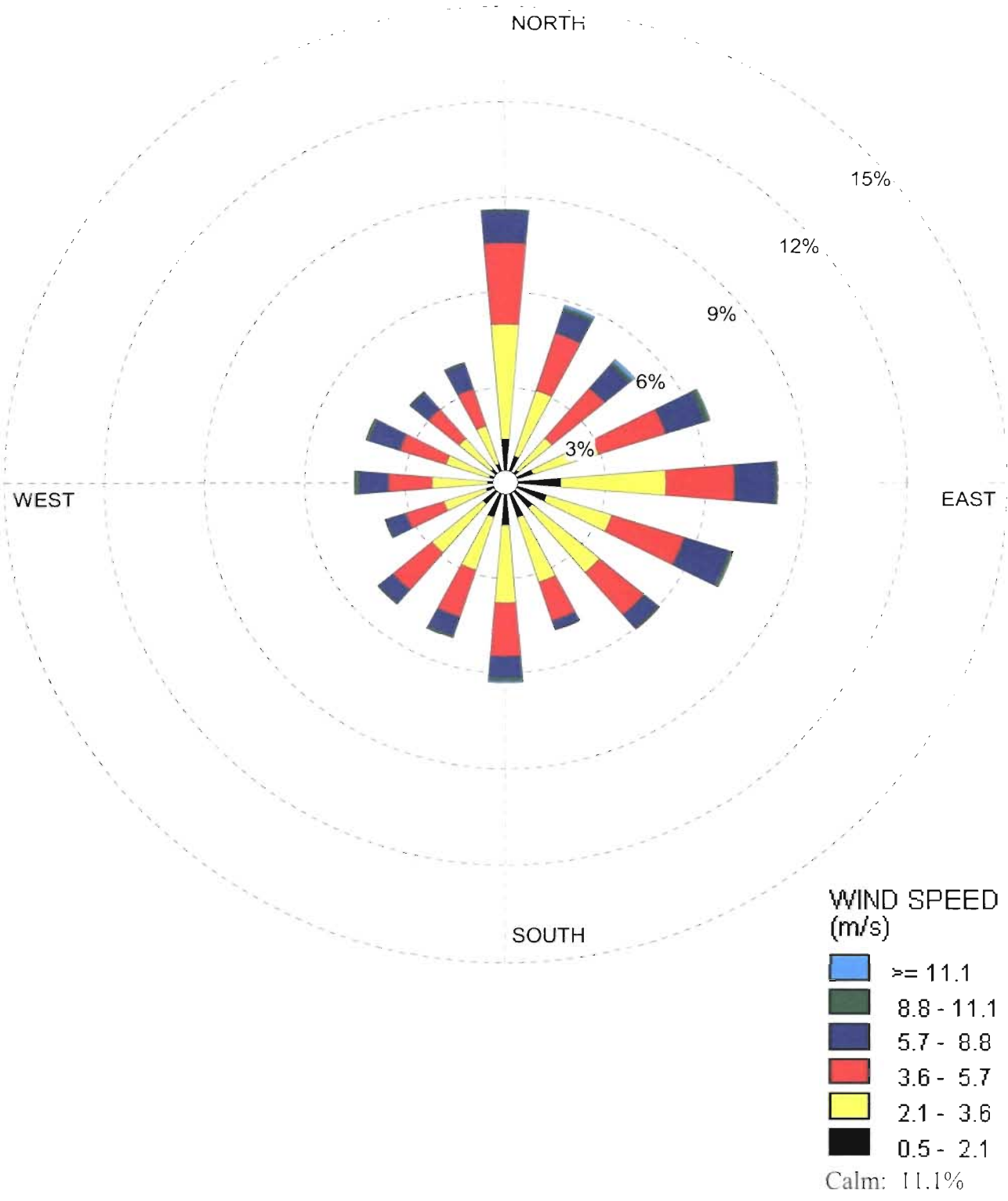

FIGURE 6-7.  
WIND ROSE FOR ORLANDO INTL AIRPORT (2003-2004)

Source: ECT, 2007. NCDC, 2007.



A summary of the surface characteristics chosen to represent PPS, TPA, and MCO is provided in Table 6-2. A comparison of the surface characteristics from PPS to TPA and MCO are shown in Table 6-3 in the form of percent differences. As shown in Table 6-3, MCO has surface characteristics that are more consistent with the PPS site than those from TPA. As a result of the surface characteristic analysis and the aforementioned wind rose data, the surface meteorological data from MCO was chosen to be representative of PPS. The combination of the surface data from MCO and upper air data from TPA provides representative estimates for both the local and regional meteorology.

## **6.10 MODELED EMISSION INVENTORY**

### **6.10.1 ON-PROPERTY SOURCES**

In addition to the two CT/HRSG units (the primary Unit 6 emission sources), Unit 6 will include feedstock receiving, storage, handling, and preparation fugitive and point sources of PM/PM<sub>10</sub>; sulfuric acid plant, flare (for combustion of syngas during gasifier start-ups/shutdowns and plant upsets); natural gas-fired auxiliary boiler (used only during gasifier startups); mechanical draft cooling tower; and three emergency diesel engines. The modeled Unit 6 emission sources included the feedstock receiving, storage, handling, and preparation fugitive and point sources, CT/HRSG units, sulfuric acid plant, and mechanical draft cooling tower.

The flare will operate intermittently during gasifier startups/shutdowns and in the event of plant upsets. The natural gas-fired auxiliary boiler will only operate during gasifier startups. Accordingly, the flare and auxiliary boiler will not be in service during normal Unit 6 operations. Each emergency diesel engine, other than during emergency conditions, will only operate approximately 2 hours per week for routine testing and maintenance purposes.

During normal operations, the CT/HRSG units will operate over a range of loads (60 to 100 percent) and ambient temperatures (0 to 100°F). A summary of the CT/HRSG operating cases evaluated is provided in Appendix A, Table A-2. Plume dispersion and, therefore, ground-level impacts, will be affected by these different operating scenarios



Table 6-2. Summary of AERMET Surface Characteristics

Sector	Beginning Angle (deg)	End Angle (deg)	Polk Power Station			Tampa Intl Airport*			Orlando Intl Airport*		
			Annual Average Albedo	Annual Average Bowen Ratio	Annual Average Surface Roughness	Annual Average Albedo	Annual Average Bowen Ratio	Annual Average Surface Roughness	Annual Average Albedo	Annual Average Bowen Ratio	Annual Average Surface Roughness
1	0	30	0.24	2.89	0.48	0.18	1.50	1.00	0.20	1.11	0.26
2	30	60	0.23	2.70	0.47	0.18	1.37	0.86	0.20	1.40	0.80
3	60	90	0.21	2.34	0.49	0.18	1.49	0.99	0.19	1.08	0.39
4	90	120	0.22	2.44	0.29	0.17	1.36	0.91	0.18	0.94	0.26
5	120	150	0.19	1.59	0.24	0.17	1.34	0.87	0.18	0.91	0.31
6	150	180	0.19	1.14	0.11	0.16	0.95	0.55	0.15	0.87	0.43
7	180	210	0.15	0.38	0.05	0.13	0.36	0.16	0.17	1.09	0.39
8	210	240	0.20	1.71	0.35	0.10	0.05	0.05	0.21	1.07	0.38
9	240	270	0.17	1.16	0.41	0.10	0.04	0.03	0.21	1.29	0.59
10	270	300	0.21	1.92	0.41	0.16	0.45	0.16	0.19	1.39	0.82
11	300	330	0.21	2.05	0.42	0.20	1.13	0.53	0.19	1.36	0.84
12	330	360	0.19	1.69	0.50	0.17	1.29	0.79	0.25	1.17	0.44

\* Surface characteristic parameters provided by FDEP.

Sources: FDEP, 2007.  
ECT, 2007.

Table 6-3. Comparison of Surface Characteristics - Polk Power Station, Tampa Intl. Airport, and Orlando Intl. Airport

Sector	Beginning Angle (deg)	End Angle (deg)	PPS vs. TPA			PPS vs. MCO		
			Annual Average Albedo	Annual Average Bowen Ratio	Annual Average Surface Roughness	Annual Average Albedo	Annual Average Bowen Ratio	Annual Average Surface Roughness
1	0	30	-24%	-48%	107%	-16%	-62%	-47%
2	30	60	-21%	-49%	83%	-13%	-48%	70%
3	60	90	-15%	-36%	101%	-10%	-54%	-20%
4	90	120	-23%	-44%	213%	-18%	-61%	-9%
5	120	150	-11%	-16%	269%	-6%	-43%	30%
6	150	180	-15%	-17%	397%	-20%	-24%	289%
7	180	210	-15%	-4%	224%	11%	191%	662%
8	210	240	-50%	-97%	-87%	5%	-37%	8%
9	240	270	-41%	-97%	-92%	23%	12%	43%
10	270	300	-22%	-77%	-61%	-8%	-28%	98%
11	300	330	-4%	-45%	25%	-9%	-34%	99%
12	330	360	-9%	-24%	58%	33%	-31%	-12%

PPS - Polk Power Station  
 TPA - Tampa International Airport  
 MCO - Orlando International Airport

Source: ECT, 2007.

since emission rates, exit temperatures, and exhaust gas velocities will change. While the primary fuel for the Unit 6 CT/HRSG units will be syngas, the units will also be capable of combusting natural gas. Since emission rates are greater for all pollutants when combusting syngas, the air quality analyses were confined to the syngas CT/HRSG operating cases. For SO<sub>2</sub> and CO, all nine syngas CT/HRSG operating cases were evaluated using the refined AERMOD dispersion model. For NO<sub>2</sub>, emissions and stack data for syngas Case 4 (100 percent load and 59°F ambient temperature) were conservatively used to obtain annual average NO<sub>2</sub> impacts. The stack temperature and PM<sub>10</sub> emission rate are essentially constant for all nine syngas operating cases. Accordingly, for PM<sub>10</sub>, data for the syngas operating case at 80 percent load and 59°F ambient temperature (i.e., Case 5) was conservatively used to obtain short-term and annual average PM<sub>10</sub> impacts.

#### **6.10.2 OFF-PROPERTY SOURCES**

Since Unit 6 maximum air quality impacts were below the PSD SILs for all PSD pollutants, a full, multi-source interactive assessment of NAAQS attainment and PSD Class II increment consumption was not required.

## 7.0 AMBIENT IMPACT ANALYSIS RESULTS

### 7.1 OVERVIEW

Comprehensive dispersion modeling was conducted to assess the air quality impacts resulting from Unit 6 operations in accordance with the methodology described in Section 6.0. This section provides the results of the Unit 6 Class II air quality assessment for SO<sub>2</sub>, NO<sub>2</sub>, CO, and PM<sub>10</sub>. Unit 6 air quality impacts at distant PSD Class I areas resulting from long-range transport are addressed in Section 10.0.

The Unit 6 CT/HRSG units will operate under a variety of operating loads (from 60 to 100 percent) and ambient temperatures (from 0 to 100°F). While the CT/HRSG stack exhaust temperature will remain constant, stack exhaust velocities will vary with load and ambient temperature as will emission rates of SO<sub>2</sub>, NO<sub>x</sub>, and CO. Based on vendor emissions data, emission rates for PM<sub>10</sub> (total filterable and condensable) remain essentially constant for each CT/HRSG operating case. For all operating cases and all pollutants, emission rates are higher when firing syngas compared to natural gas-firing. Accordingly, the modeling analysis for the CT/HRSG units was confined to syngas-firing only. Predictions of maximum air quality impacts for the Unit 6 CT/HRSG units were developed using the AERMOD dispersion model as follows:

- SO<sub>2</sub> and CO—Each of the nine CT/HRSG operating cases (a three-by-three matrix of 60, 80, and 100 percent loads and 0, 59, and 100°F ambient temperatures) were evaluated to obtain both short (1, 3, 8, and 24 hour) and long- (annual) term average impacts.
- NO<sub>2</sub>—Case 4 conditions (100 percent load and 59°F ambient temperature) were used to obtain annual average impacts.
- PM<sub>10</sub>—Case 5 conditions (80 load and 59°F ambient temperature) were used to obtain both short (24 hour) and long- (annual) term average impacts.

This modeling approach for the Unit 6 CT/HRSG units is conservative (i.e., will tend to over-estimate air quality impacts). For the short-term averaging periods, maximum impacts will be over-estimated since many of the modeled CT/HRSG operating cases would not be expected to persist for these averaging periods (e.g., low-load operation and 0 and

100°F ambient temperatures). Similarly, the Case 4 operating conditions (100 percent load and 59°F ambient temperature) used to obtain annual average NO<sub>2</sub> impacts would be expected to over-estimate impacts since CT/HRSG loads and NO<sub>2</sub> mass emission rates will decrease with increasing ambient temperature, and the average annual temperature at PPS is greater than 59°F. Case 5 was selected for PM<sub>10</sub> assessments since this operating case represents a conservative estimate of 24-hour average impacts.

In addition to the Unit 6 CT/HRSG units, the Class II air quality analysis also included emissions from the sulfuric acid plant (for SO<sub>2</sub> and PM<sub>10</sub>), cooling tower (for PM<sub>10</sub>), and feedstock receiving, storage, handling and preparation (for PM<sub>10</sub>). For assessment of Unit 6 PM<sub>10</sub> impacts, H<sub>2</sub>SO<sub>4</sub> mist emissions from the sulfuric acid plant were assumed equal to PM<sub>10</sub> emissions.

## **7.2 PSD SIL ANALYSIS RESULTS**

Comprehensive dispersion modeling using the EPA AERMOD dispersion model demonstrates that operation of Unit 6 will result in ambient air quality impacts that are below the PSD Class II SILs for all pollutants and all averaging periods. Accordingly, no further modeling analysis with respect to the PSD Class II increments or NAAQS is required.

Detailed Unit 6 AERMOD results for each year of meteorology are summarized in Table 7-1 (NO<sub>2</sub>), Table 7-2 (SO<sub>2</sub>), Table 7-3 (PM<sub>10</sub>), and Table 7-4 (CO). These tables provide maximum Unit 6 impacts, the locations of these impacts, and relevant regulatory criteria.

Maximum Unit 6 air quality impacts using AERMOD and the identified worst-case operating cases are summarized in Table 7-5. The AERMOD results presented in Table 7-5 demonstrates that Unit 6 air quality impacts, for all pollutants and averaging periods, will be below the PSD SILs previously shown in Table 3-4. As previously noted, the Class II impact results over-estimate actual air quality impacts due to the conservative modeling approach taken.

Table 7-1. Unit 6 - Maximum Class II NO<sub>2</sub> Impacts

Parameter	Units	Year of Meteorology					Maximum
		1999	2000	2001	2002	2003	
Annual NO <sub>2</sub> Impact <sup>1</sup>	µg/m <sup>3</sup>	0.49	0.52	0.50	0.55	0.48	0.55
Tier 2 Annual NO <sub>2</sub> Impact	µg/m <sup>3</sup>	0.37	0.39	0.37	0.41	0.36	0.41
Annual Impact Location							
Receptor UTM Easting Coordinate (X)	meters	401,159	401,189	401,189	401,129	401,189	401,129
Receptor UTM Northing Coordinate (Y)	meters	3,067,583	3,067,621	3,067,621	3,067,544	3,067,621	3,067,544
Receptor Elevation	meters	42.7	42.7	42.7	42.7	42.7	43
Distance from Stack <sup>2</sup>	meters	1,587	1,580	1,580	1,595	1,580	1,595
Direction Vector from Stack <sup>3</sup>	degrees	300	302	302	298	302	298
PSD SIL	µg/m <sup>3</sup>	1	1	1	1	1	1
Exceed SIL	Y/N	N	N	N	N	N	N
Percent of SIL	%	36.8	38.7	37.0	41.1	36.2	41.1
PSD <i>de minimis</i> Ambient Impact	µg/m <sup>3</sup>	14	14	14	14	14	14
Exceed PSD <i>de minimis</i> Ambient Impact	Y/N	N	N	N	N	N	N
Percent of PSD <i>de minimis</i> Ambient Impact	%	2.6	2.8	2.6	2.9	2.6	2.9

<sup>1</sup> Case 4 - 100% load and 59 °F ambient temperature.

<sup>2</sup> Distance from the Train 1 CT/HRSG stack to the location of highest impact.

<sup>3</sup> Direction from stack toward impact location. For example, 90° means the highest impact is located due east of the Train 1 CT/HRSG stack.

Source: ECT, 2007.

7-3

Table 7-2. Unit 6 - Maximum Class II SO<sub>2</sub> Impacts

Parameter	Units	Year of Meteorology					Maximum
		1999	2000	2001	2002	2003	
<b>A. Annual Average Impacts</b>							
Annual SO <sub>2</sub> Impact <sup>1</sup>	µg/m <sup>3</sup>	0.40	0.41	0.42	0.45	0.43	0.45
Annual Impact Location							
Receptor UTM Easting Coordinate (X)	meters	401,129	401,159	401,092	401,129	401,189	401,129
Receptor UTM Northing Coordinate (Y)	meters	3,067,544	3,067,583	3,065,601	3,067,544	3,067,621	3,067,544
Receptor Elevation	meters	42.7	42.7	42.7	42.7	42.7	42.7
Distance from Stack <sup>2</sup>	meters	1,595	1,587	1,869	1,595	1,580	1,595
Direction Vector from Stack <sup>3</sup>	degrees	298	300	230	298	302	298
PSD SIL	µg/m <sup>3</sup>	1	1	1	1	1	1
Exceed SIL	Y/N	N	N	N	N	N	N
Percent of SIL	%	40.2	41.0	42.1	45.3	42.8	45.3
<b>B. 24-Hour Average Impacts</b>							
24-Hour SO <sub>2</sub> Impact <sup>1</sup>	µg/m <sup>3</sup>	3.8	4.8	4.7	3.9	4.5	4.8
24-Hour Impact Location							
Receptor UTM Easting Coordinate (X)	meters	404,026	401,189	402,785	401,116	402,980	402,785
Receptor UTM Northing Coordinate (Y)	meters	3,068,141	3,067,621	3,065,693	3,065,553	3,065,682	3,065,693
Receptor Elevation	meters	44.1	42.7	41.2	42.7	41.2	41.2
Distance from Stack <sup>2</sup>	meters	2,013	1,580	1,126	1,881	1,195	1,126
Direction Vector from Stack <sup>3</sup>	degrees	48	302	167	229	158	167
PSD SIL	µg/m <sup>3</sup>	5	5	5	5	5	5
Exceed SIL	Y/N	N	N	N	N	N	N
Percent of SIL	%	75.6	95.3	93.7	77.5	90.3	95.3
PSD <i>de minimis</i> Ambient Impact	µg/m <sup>3</sup>	13	13	13	13	13	13
Exceed PSD <i>de minimis</i> Ambient Impact	Y/N	N	N	N	N	N	N
Percent of PSD <i>de minimis</i> Ambient Impact	%	29.1	36.7	36.1	29.8	34.7	36.7

7-4

Table 7-2. Unit 6 - Maximum Class II SO<sub>2</sub> Impacts

Parameter	Units	Year of Meteorology					Maximum
		1999	2000	2001	2002	2003	
<b>C. 3-Hour Average Impacts</b>							
3-Hour SO <sub>2</sub> Impact <sup>1</sup>	µg/m <sup>3</sup>	10.6	13.9	15.4	9.5	14.5	15.4
3-Hour Impact Location							
Receptor UTM Easting Coordinate (X)	meters	404,028	404,157	401,159	404,065	401,189	401,159
Receptor UTM Northing Coordinate (Y)	meters	3,068,718	3,067,653	3,067,583	3,067,863	3,067,621	3,067,583
Receptor Elevation	meters	43.8	43.0	42.7	43.2	42.7	42.7
Distance from Stack <sup>2</sup>	meters	2,439	1,838	1,587	1,869	1,580	1,587
Direction Vector from Stack <sup>3</sup>	degrees	38	62	300	55	302	300
PSD SIL	µg/m <sup>3</sup>	25.0	25.0	25.0	25.0	25.0	25.0
Exceed SIL	Y/N	N	N	N	N	N	N
Percent of SIL	%	42.6	55.4	61.7	38.1	58.1	61.7

<sup>1</sup> Highest impact for all nine operating cases.

<sup>2</sup> Distance from the Train 1 CT/HRSG stack to the location of highest impact.

<sup>3</sup> Direction from stack toward impact location. For example, 90° means the highest impact is located due east of the Train 1 CT/HRSG stack.

Source: ECT, 2007.



Table 7-3. Unit 6 - Maximum Class II PM<sub>10</sub> Impacts

Parameter	Units	Year of Meteorology					Maximum
		1999	2000	2001	2002	2003	
<b>A. Annual Average Impacts</b>							
Annual PM <sub>10</sub> Impact <sup>1</sup>	µg/m <sup>3</sup>	0.40	0.40	0.43	0.44	0.41	0.44
Annual Impact Location							
Receptor UTM Easting Coordinate (X)	meters	401,129	401,159	401,159	401,129	401,189	401,129
Receptor UTM Northing Coordinate (Y)	meters	3,067,544	3,067,583	3,067,583	3,067,544	3,067,621	3,067,544
Receptor Elevation	meters	42.7	42.7	42.7	42.7	42.7	42.7
Distance from Stack <sup>2</sup>	meters	1,595	1,587	1,587	1,595	1,580	1,595
Direction Vector from Stack <sup>3</sup>	degrees	298	300	300	298	302	298
PSD SIL	µg/m <sup>3</sup>	1	1	1	1	1	1
Exceed SIL	Y/N	N	N	N	N	N	N
Percent of SIL	%	40.5	40.3	43.2	43.8	40.7	43.8
<b>B. 24-Hour Average Impacts</b>							
24-Hour PM <sub>10</sub> Impact <sup>1</sup>	µg/m <sup>3</sup>	3.6	4.9	4.3	3.5	3.9	4.9
24-Hour Impact Location							
Receptor UTM Easting Coordinate (X)	meters	401,129	401,159	401,129	401,098	401,189	401,129
Receptor UTM Northing Coordinate (Y)	meters	3,067,544	3,067,583	3,067,544	3,067,506	3,067,621	3,067,544
Receptor Elevation	meters	42.7	42.7	42.7	42.9	42.7	42.7
Distance from Stack <sup>2</sup>	meters	1,595	1,587	1,595	1,604	1,580	1,604
Direction Vector from Stack <sup>3</sup>	degrees	298	300	298	297	302	297
PSD SIL	µg/m <sup>3</sup>	5	5	5	5	5	5
Exceed SIL	Y/N	N	N	N	N	N	N
Percent of SIL	%	71.6	99.9	86.0	69.7	78.1	99.9
PSD <i>de minimis</i> Ambient Impact	µg/m <sup>3</sup>	10	10	10	10	10	10
Exceed PSD <i>de minimis</i> Ambient Impact	Y/N	N	N	N	N	N	N
Percent of PSD <i>de minimis</i> Ambient Impact	%	35.8	48.8	43.0	34.8	39.1	48.8

<sup>1</sup> Case 9 - 60% load and 100 °F ambient temperature.

<sup>2</sup> Distance from the Train 1 CT/HRSG stack to the location of highest impact.

<sup>3</sup> Direction from stack toward impact location. For example, 90° means the highest impact is located due east of the Train 1 CT/HRSG stack.

Source: ECT, 2007.

Table 7-4. Unit 6 - Maximum Class II CO Impacts

Parameter	Units	Year of Meteorology					Maximum
		1999	2000	2001	2002	2003	
<b>A. 8-Hour Average Impacts</b>							
8-Hour CO Impact <sup>1</sup>	µg/m <sup>3</sup>	11.1	13.4	13.4	11.8	10.8	13.4
8-Hour Impact Location							
Receptor UTM Easting Coordinate (X)	meters	401,129	401,159	401,159	401,129	401,189	401,129
Receptor UTM Northing Coordinate (Y)	meters	3,067,544	3,067,583	3,067,583	3,067,544	3,067,621	3,067,544
Receptor Elevation	meters	42.7	42.7	42.7	42.7	42.7	42.7
Distance from Stack <sup>2</sup>	meters	1,595	1,587	1,587	1,595	1,580	1,595
Direction Vector from Stack <sup>3</sup>	degrees	298	300	300	298	302	298
PSD SIL	µg/m <sup>3</sup>	500	500	500	500	500	500
Exceed SIL	Y/N	N	N	N	N	N	N
Percent of SIL	%	2.2	2.7	2.7	2.4	2.2	2.7
PSD <i>de minimis</i> Ambient Impact	µg/m <sup>3</sup>	575	575	575	575	575	575
Exceed PSD <i>de minimis</i> Ambient Impact	Y/N	N	N	N	N	N	N
Percent of PSD <i>de minimis</i> Ambient Impact	%	1.9	2.3	2.3	2.1	1.9	2.3
<b>B. 1-Hour Average Impacts</b>							
1-Hour CO Impact <sup>1</sup>	µg/m <sup>3</sup>	45.3	47.7	48.4	47.1	42.7	48.4
1-Hour Impact Location							
Receptor UTM Easting Coordinate (X)	meters	401,069	401,159	401,159	401,098	401,129	401,159
Receptor UTM Northing Coordinate (Y)	meters	3,067,500	3,067,583	3,067,583	3,067,506	3,067,544	3,067,583
Receptor Elevation	meters	43.0	42.7	42.7	42.9	42.7	42.7
Distance from Stack <sup>2</sup>	meters	1,628	1,587	1,587	1,604	1,595	1,604
Direction Vector from Stack <sup>3</sup>	degrees	296	300	300	297	298	297
PSD SIL	µg/m <sup>3</sup>	2,000	2,000	2,000	2,000	2,000	2,000
Exceed SIL	Y/N	N	N	N	N	N	N
Percent of SIL	%	2.3	2.4	2.4	2.4	2.1	2.4

<sup>1</sup> Highest impact for all nine operating cases.

<sup>2</sup> Distance from the Train 1 CT/HRSG stack to the location of highest impact.

<sup>3</sup> Direction from stack toward impact location. For example, 90° means the highest impact is located due east of the Train 1 CT/HRSG stack.

Source: ECT, 2007.

7-7

Table 7-5. Unit 6 - Summary of Class II Impacts

Pollutant	Year of Meteorology					Maximum	PSD SIL
	1999	2000	2001	2002	2003		
<b>A. NO<sub>2</sub> Impacts</b>							
Annual Tier II Impact (µg/m <sup>3</sup> )	0.37	0.39	0.37	0.41	0.36	0.41	1
<b>B. SO<sub>2</sub> Impacts</b>							
Annual Impact (µg/m <sup>3</sup> )	0.40	0.41	0.42	0.45	0.43	0.45	1
24-Hour Impact (µg/m <sup>3</sup> )	3.8	4.8	4.7	3.9	4.5	4.8	5
3-Hour Impact (µg/m <sup>3</sup> )	10.6	13.9	15.4	9.5	14.5	15.4	25
<b>C. PM<sub>10</sub> Impacts</b>							
Annual Impact (µg/m <sup>3</sup> )	0.40	0.40	0.43	0.44	0.41	0.44	1
24-Hour Impact (µg/m <sup>3</sup> )	3.6	4.9	4.3	3.5	3.9	4.9	5
<b>D. CO Impacts</b>							
8-Hour Impact (µg/m <sup>3</sup> )	11.1	13.4	13.4	11.8	10.8	13.4	500
1-Hour Impact (µg/m <sup>3</sup> )	45.3	47.7	48.4	47.1	42.7	48.4	2,000

Source: ECT, 2007.

### 7.3 OZONE IMPACTS

Ozone is formed in a complex series of chemical reactions involving primarily NO<sub>x</sub> and VOCs during warm ambient temperatures in the presence of sunlight. Since ozone is formed from precursor pollutants, assessment of ambient ozone impacts is typically conducted on a regional basis using resource-intensive models such as the EPA Community Multiscale Air Quality (CMAQ) model. Currently, all areas of Florida are attaining the 8-hour ozone AAQS.

Unit 6 estimated potential NO<sub>x</sub> and VOC emissions are 925 and 38 tpy, respectively. These annual emission rates are relatively minor in comparison to regional emissions. For example, Hillsborough County NO<sub>x</sub> and VOC emissions in 2001 were 103,401 and 53,740 tons, respectively, based on data obtained from the EPA AirData Web site. NO<sub>x</sub> and VOC emissions for Polk County in 2001 were 33,598 and 33,464 tons, respectively. Hillsborough County, which has a higher population density and greater NO<sub>x</sub> and VOC emissions compared to Polk County, currently has monitored ambient ozone levels below the ozone AAQS.

Ambient ozone levels in Polk County are primarily due to ozone transport from upwind areas. Despite significant increases in population and motor vehicle activity, ambient ozone air quality in Florida has improved over the last 5 years due to improvements in motor vehicle emission rates. Continued reductions in average motor fleet emissions would be expected to further improve ozone air quality. In addition, the CAIR will result in significant actual reductions in existing power plant NO<sub>x</sub> emissions throughout Florida. During Phase 1 (2009 through 2014) of the CAIR program, EPA estimates that actual Florida power plant NO<sub>x</sub> emissions during the 5-month ozone season (May through September) will be reduced from 119,000 tons (in 2003) to 33,000 tons—a reduction of 86,000 tons. In comparison, Unit 6 estimated ozone season NO<sub>x</sub> emissions will be only approximately 385 tons. The CAIR program power plant emission reductions will occur throughout Florida, including areas in the vicinity of Polk County, and will occur prior to the commencement of operation of Unit 6. As an example, Lakeland Electric is retrofitting emission control systems to its existing McIntosh Generating Station Unit 3 that will

result in an estimated annual reduction in actual NO<sub>x</sub> emissions of 2,350 tons, which is approximately 2.5 times higher than the estimated Unit 6 NO<sub>x</sub> emissions.

In summary, the relatively minor NO<sub>x</sub> and VOC emissions associated with Unit 6 will not significantly impact ambient ozone levels in Polk County or other areas in Florida. Polk County is projected to remain in compliance with the ozone ambient quality standard due to the continued significant reductions in regional motor vehicle and power plant emissions.

#### **7.4 AIR TOXICS MODELING RESULTS**

The refined AERMOD modeling system was also used to assess Unit 6 impacts with respect to toxic air pollutants. Table 7-6 shows maximum Unit 6 air quality impacts for a variety of metallic and organic toxic air pollutants in comparison to chronic exposure criteria obtained from EPA's Integrated Risk Information System (IRIS). As shown in Table 7-6, all Unit 6 ambient impacts with respect to air toxics are well below the EPA recommended exposure criteria.

#### **7.5 MERCURY IMPACTS**

Although not subject to PSD review, assessment of mercury impacts in the vicinity of the PPS due to Unit 6 emissions was conducted.

The combustion of syngas containing mercury may result in emissions of elemental mercury, RGM, and/or particle-bound mercury. Particle-bound mercury is emitted in particulate form, while both elemental mercury and RGM are released in the gaseous state. The deposition characteristics of each of these three mercury species differ. Elemental mercury has a long residence time in the atmosphere and travels long distances (i.e., greater than 50 km) before it is ultimately deposited on the Earth's surface. The other two forms of mercury, RGM and particle-bound mercury, will deposit locally (i.e., within 50 km) and regionally (i.e., from 50 km to several thousand km). The dispersion of elemental mercury is evaluated on regional and global scales and, therefore, was not considered for the analysis of local mercury deposition due to Unit 6.

Table 7-6. Toxic Air Pollutant Impacts

Chemical Compound	CT/HRSG Emissions <sup>a</sup>		CT/HRSG Impacts (ug/m <sup>3</sup> ) <sup>b</sup>		Inhalation Unit Risk Factor (URF) <sup>c</sup> (ug/m <sup>3</sup> ) <sup>-1</sup>	Inhalation Reference Concentration (RfC) <sup>c</sup> (ug/m <sup>3</sup> )	Cancer Risk <sup>d</sup> (unitless)	Hazard Quotient <sup>e</sup> (unitless)
	(lb/hr)	(g/s)	24-Hour	Annual				
2-Methylnaphthalene	9.26E-04	1.17E-04	7.30E-05	5.11E-06	NA	NA	NA	NA
Acenaphthalene	6.69E-05	8.43E-06	5.27E-06	3.69E-07	NA	NA	NA	NA
Acetaldehyde	4.63E-03	5.84E-04	3.65E-04	2.55E-05	2.20E-06	9.00E+00	5.62E-11	2.84E-06
Antimony	1.00E-02	1.26E-03	7.91E-04	5.53E-05	NA	2.00E-01	NA	2.77E-04
Arsenic	7.71E-03	9.73E-04	6.08E-04	4.26E-05	4.30E-03	5.00E-01	1.83E-07	8.51E-05
Benzaldehyde	7.46E-03	9.40E-04	5.88E-04	4.11E-05	NA	NA	NA	NA
Benzene	1.13E-02	1.43E-03	8.92E-04	6.24E-05	7.80E-06	3.00E+01	4.87E-10	2.08E-06
Benzo(a)anthracene	5.91E-06	7.46E-07	4.66E-07	3.26E-08	1.10E-04	NA	3.59E-12	NA
Benzo(e)pyrene	1.41E-05	1.78E-06	1.12E-06	7.80E-08	8.86E-04	NA	6.91E-11	NA
Benzo(g,h,i)perylene	2.44E-05	3.08E-06	1.93E-06	1.35E-07	NA	NA	NA	NA
Beryllium	2.37E-03	2.98E-04	1.87E-04	1.31E-05	2.40E-03	2.00E-02	3.13E-08	6.53E-04
Cadmium	1.08E-02	1.36E-03	8.52E-04	5.96E-05	1.80E-03	2.00E-01	1.07E-07	2.98E-04
Carbon Disulfide	1.16E-01	1.46E-02	9.12E-03	6.38E-04	NA	7.00E+02	NA	9.12E-07
Chromium (III)	9.77E-03	1.23E-03	7.70E-04	5.39E-05	NA	6.83E+01	NA	7.90E-07
Cobalt	2.08E-03	2.63E-04	1.64E-04	1.15E-05	NA	NA	NA	NA
Formaldehyde	4.37E-02	5.51E-03	3.45E-03	2.41E-04	1.30E-05	NA	3.14E-09	NA
Hydrogen Chloride	2.70E-01	3.41E-02	2.13E-02	1.49E-03	NA	2.00E+01	NA	7.46E-05
Hydrogen Fluoride	1.44E-01	1.82E-02	1.14E-02	7.94E-04	NA	NA	NA	NA
Lead	1.03E-02	1.30E-03	8.11E-04	5.67E-05	NA	9.00E-02	NA	6.31E-04
Manganese	1.11E-02	1.39E-03	8.72E-04	6.10E-05	NA	5.00E-02	NA	1.22E-03
Mercury	3.20E-03	4.03E-04	2.52E-04	1.76E-05	NA	3.00E-01	NA	5.88E-05
Naphthalene	1.03E-03	1.30E-04	8.11E-05	5.67E-06	NA	3.00E+00	NA	1.89E-06
Nickel	1.44E-02	1.82E-03	1.14E-03	7.94E-05	2.40E-04	5.00E-02	1.91E-08	1.59E-03
Selenium	1.11E-02	1.39E-03	8.72E-04	6.10E-05	NA	5.00E-01	NA	1.22E-04
						Hazard Index <sup>f</sup>	3.44E-07	0.0050
						Risk Indicators	1.00E-06	1.0
						Percent of Indicator	34.4%	0.5%

Note: NA = not available.

<sup>a</sup> Emission rates for each CT/HRSG unit during syngas combustion; Case 4 (100% load, 59°F ambient temperature).

<sup>b</sup> Impacts for two CT/HRSG units.

<sup>c</sup> EPA Integrated Risk Information System (IRIS).

<sup>d</sup> Inhalation unit risk factor multiplied by annual average impact.

<sup>e</sup> Annual average impact divided by inhalation reference concentration.

<sup>f</sup> Sum of cancer risks or hazard quotients.

Sources: ECT, 2007.  
EPA, 2007.

11-7

Unit 6 is projected to emit up to 53.8 lb/yr of mercury. Of this total, 90 percent (i.e., 48.4 lb/yr) will be emitted as elemental mercury, 10 percent (i.e., 5.4 lb/yr) as RGM, and only trace amounts as particulate mercury.

Dry, wet, and total RGM deposition for Unit 6 was estimated using the wet and dry algorithms contained in the current version of the EPA AERMOD dispersion model with RGM-specific parameters drawn from EPA and literature references. The general modeling procedures and options specified in the current versions of the AERMOD User's Guide (EPA, 2004b) and the GAQM were followed. Modeling was conducted in a manner consistent with EPA guidance and standard practices, including the use of regulatory default options, as appropriate. The specific modeling procedures are the same as those described in Section 6.0 with respect to building downwash, terrain elevations, receptor grids, and meteorological data.

The results of the Unit 6 mercury deposition assessment are presented in Table 7-7. The predicted Unit 6 maximum annual areal average (i.e., average RGM deposition for receptors located throughout a 20-km<sup>2</sup> area) total (dry and wet) RGM deposition rate is 0.1935 microgram per square meter per year ( $\mu\text{g}/\text{m}^2/\text{yr}$ ) for the 5 years of historical meteorological data evaluated (i.e., 1999 through 2003). The dry and wet RGM deposition components of this total deposition rate are 0.1828 (94.5 percent of total) and 0.0128 (5.5 percent of total)  $\mu\text{g}/\text{m}^2/\text{yr}$ , respectively. Although maximum RGM concentrations and deposition rates predicted for a single receptor are considered less meaningful than the areal average values, the Unit 6 single point maximum annual average deposition and concentration values are also provided in Table 7-7.

There are no observational data for total mercury deposition to provide context for the estimated values. However, observational data do exist for wet deposition of mercury (which, except in highly polluted urban atmospheres where particulate mercury can be important, is largely driven by RGM scavenging) and ambient RGM concentrations (to which RGM dry deposition is directly related). Using such data, the estimated wet and dry components of total deposition can be assessed separately to provide context for the

Table 7-7. Unit 6 Mercury Deposition and Concentration Impacts

Maximum and Areal Average Annual Impacts	1999	2000	2001	2002	2003	Maximum
<u>Maximum Impacts</u>						
Total Deposition ( $\mu\text{g}/\text{m}^2/\text{yr}$ )	1.15	1.20	1.38	1.21	1.22	1.38
Dry Deposition ( $\mu\text{g}/\text{m}^2/\text{yr}$ )	1.12	1.18	1.32	1.17	1.18	1.32
Wet Deposition ( $\mu\text{g}/\text{m}^2/\text{yr}$ )	0.06	0.04	0.06	0.07	0.06	0.07
Receptor UTM Easting Coordinate (meters)*	401,034	401,034	401,034	404,034	404,034	401,034
Receptor UTM Northing Coordinate (meters)*	3,065,290	3,065,290	3,065,290	3,065,790	3,065,790	3,065,290
Distance From Unit 6 (meters)	2,299	2,299	2,299	1,493	1,493	2,299
Direction From Unit 6 (Vector $^{\circ}$ )	232	232	232	128	128	232
Concentration ( $\text{ng}/\text{m}^3$ )	0.00116	0.00129	0.00126	0.00128	0.00125	0.00129
Receptor UTM Easting (meters)	401,034	402,534	401,034	401,034	401,034	402,534
Receptor UTM Northing (meters)	3,067,790	3,065,290	3,067,790	3,067,790	3,067,790	3,065,290
Distance From Unit 6 (meters)	2,118	1,445	2,118	2,118	2,118	1,445
Direction From Unit 6 (Vector $^{\circ}$ )	301	193	301	301	301	193
<u>Areal Average Impacts (within 20-km<sup>2</sup> Area)</u>						
Total Deposition ( $\mu\text{g}/\text{m}^2/\text{yr}$ )	0.1868	0.1876	0.1935	0.1868	0.1841	0.1935
Dry Deposition ( $\mu\text{g}/\text{m}^2/\text{yr}$ )	0.1766	0.1815	0.1828	0.1740	0.1737	0.1828
Wet Deposition ( $\mu\text{g}/\text{m}^2/\text{yr}$ )	0.0101	0.0061	0.0106	0.0128	0.0105	0.0128
Concentration ( $\text{ng}/\text{m}^3$ )	0.000157	0.000158	0.000160	0.000162	0.000155	0.000162

\*Location of maximum total deposition impact.

Source: ECT, 2007.



estimated values. The nearest National Atmospheric Deposition Program (NADP) Mercury Deposition Network (MDN) ambient monitoring station is located in the Chassahowitzka NWA (Station No. FL05; 117 km from Unit 6) NADP MDN data for 2006 shows an average wet mercury deposition rate of  $15.7 \mu\text{g}/\text{m}^2/\text{yr}$  for the Chassahowitzka NWA monitoring station. This is 1,227 times greater than the estimated wet RGM deposition rate for Unit 6. Accordingly, the Unit 6 estimated maximum annual areal average wet RGM deposition rate of  $0.0128 \mu\text{g}/\text{m}^2/\text{yr}$  is only 0.08 percent of the observed wet deposition rate at the Chassahowitzka NWA monitoring station. Unit 6 wet RGM deposition at the more distant Class I areas will be significantly lower than those predicted locally for Polk County.

Since observed dry RGM deposition data are not available, a comparison was made between the predicted Unit 6 maximum annual areal average ambient air RGM concentrations and measurements of RGM air concentrations that have been conducted in Florida. The predicted Unit 6 maximum annual areal average RGM ambient air concentration is 0.000162 nanogram per cubic meter ( $\text{ng}/\text{m}^3$ ). Florida-observed RGM ambient air concentrations include values of 0.015 and  $0.005 \text{ ng}/\text{m}^3$  for sampling sites located in the Everglades and Pompano Beach, respectively (Malcolm and Keeler, 2002; Malcolm *et al.*, 2003). It is noted that the observed data are for 1-month sampling campaigns and are not directly comparable to the estimated annual average. Nevertheless, they provide some perspective on the Unit 6 estimated values, which are small in comparison (i.e., 1.1 to 3.2 percent of the observed concentrations).

Unit 6 mercury emissions will be insignificant for the following reasons:

- The Unit 6 syngas clean-up process will include carbon adsorption beds that will remove 90 percent of the mercury contained in the gasifier feedstocks. The principal forms of mercury resulting from coal gasification are elemental and reactive. RGM is estimated to be less than 10 percent of total Unit 6 mercury emissions. An engineering assumption of 10-percent RGM was conservatively used for the Unit 6 mercury impact assessment. Accordingly, at least 90 percent of the Unit 6 mercury emitted will be in the elemental form, though the actual percentage is likely to be larger. RGM, in contrast to

elemental mercury, is the emitted form of mercury which exhibits the greatest potential for *local* deposition (e.g., within 50 km, or approximately 30 miles).

- The projected Unit 6 total mercury emissions ( $7.5 \times 10^{-6}$  lb/MWh) are 38 percent of the emission limit ( $20 \times 10^{-6}$  lb/MWh) specified under the CAMR for IGCC facilities. The CAMR mercury emission limits were established by EPA with the goal of reducing mercury emissions nationwide, and thereby protecting human and environmental health. EPA concluded that emissions limits established under CAMR will not result in *hotspots*, or local areas of elevated deposition.
- Localized hotspots of elevated mercury deposition have not been identified in situations where mercury emissions were known to be much greater (approximately 350 to 2,100 lb/yr; Sullivan, 2005) in comparison to the mercury emissions projected for Unit 6 (53.8 lb/yr). In addition, RGM values for the three plants in the 2005 study ranged from 16 to 60 percent of the total mercury emissions, considerably greater than the 10-percent RGM value conservatively projected for Unit 6.
- In addition to CAMR, EPA promulgated the CAIR in 2006 which will reduce electric utility SO<sub>2</sub>, NO<sub>x</sub>, and PM/PM<sub>10</sub> emissions. Emission reductions required by CAIR will have a co-benefit of additional mercury reductions beyond those required by CAMR. Unit 6 mercury emissions will be well below the limits established by CAMR, further minimizing Unit 6 impacts on human health and the environment.
- The dry-plus-wet deposition rate for mercury emitted by Unit 6 is estimated to be no greater than 0.1935  $\mu\text{g}/\text{m}^2/\text{yr}$  averaged over a 20-km<sup>2</sup> area (range 0.1841 to 0.1935  $\mu\text{g}/\text{m}^2/\text{yr}$ ), based upon the most recent 5 years of meteorological data. This quantity of mercury deposition is 81 times less than the existing annual wet-only deposition rate recorded at the nearest location within the NADP MDN located 73 miles from Unit 6 (i.e., 15.7  $\mu\text{g}/\text{m}^2/\text{yr}$  at the Chassahowitzka NWA).

In summary, mercury emissions from Unit 6 will be low and will not represent a health or environmental concern.

## **8.0 AMBIENT AIR QUALITY MONITORING AND ANALYSIS**

### **8.1 EXISTING AMBIENT AIR QUALITY MONITORING DATA**

The nearest ambient air quality monitoring station is located at Anderson and Pine Crest Roads in Mulberry, Polk County, approximately 14 km northwest of the PPS. This station monitors the ambient air for PM<sub>10</sub> and SO<sub>2</sub>. The nearest ambient air quality monitoring station that monitors for 1- and 8-hour average ozone is located on CR 39 in Fort Lonesome, Hillsborough County, approximately 18 km west of the Project site. The nearest NO<sub>2</sub> ambient air quality monitoring station is located on North Dover Road in Plant City, Hillsborough County, approximately 35 km northwest of the PPS Site. The nearest CO ambient air quality monitoring station is also located in Plant City at One Raider Place, approximately 32 km northwest of the project site. The nearest ambient air quality monitoring station for lead is situated in Tampa, Hillsborough County, approximately 47 km north west of the PPS.

Table 8-1 provides summaries of the 2002 through 2006 ambient air quality data for these monitoring stations for PM<sub>10</sub>, PM<sub>2.5</sub>, SO<sub>2</sub>, NO<sub>2</sub>, CO, and lead. A summary of the 2002 through 2006 ambient air quality data for ozone is provided in Table 8-2.

### **8.2 PRECONSTRUCTION AMBIENT AIR QUALITY MONITORING EXEMPTION APPLICABILITY**

As previously discussed in Section 3.2, PSD review may require continuous ambient air monitoring data to be collected in the area of the proposed source for pollutants emitted in significant amounts. Because several PSD pollutants will be emitted from Unit 6 in excess of their respective significant emission rates, preconstruction monitoring is required. However, Rule 62-212.400(2)(e), F.A.C., provides for an exemption from the preconstruction monitoring requirement for sources with *de minimis* air quality impacts. The *de minimis* ambient impact levels were previously presented in Table 3-1. To assess the appropriateness of monitoring exemptions, dispersion modeling analyses were performed to determine the maximum pollutant concentrations caused by emissions from Unit 6.

Table 8-1. Polk County Area Ambient Air Quality Data  
 2002 - 2006 Data for PM<sub>10</sub>, PM<sub>2.5</sub>, SO<sub>2</sub>, NO<sub>2</sub>, CO, and Lead

Pollutant	Site Location		Site Name	Site No.	Distance From Site (km)	Direction From Site (Vector °)	Year	Averaging Period	No. of Observations	Ambient Concentration (ug/m <sup>3</sup> )											
	County	City								1st High	2nd High	Arithmetic Mean	Standard	Percent of Standard							
PM <sub>10</sub>	Polk	Mulberry	Mulberry High School	121052006	19	9	2002	24-hour	362	165**	78		150 <sup>a</sup>	52.0							
							2003	24-hour	355	59	49		150 <sup>a</sup>	39.3							
							2004	24-hour	347	68	50		150 <sup>a</sup>	45.3							
							2005	24-hour	355	61	57		150 <sup>a</sup>	40.7							
							2006	24-hour	348	81	56		150 <sup>a</sup>	54.0							
							2002	Annual	362			21	50 <sup>b</sup>	42.0							
							2003	Annual	355			20	50 <sup>b</sup>	40.0							
							2004	Annual	347			21	50 <sup>b</sup>	42.0							
							2005	Annual	355			20	50 <sup>b</sup>	40.0							
							2006	Annual	348			21	50 <sup>b</sup>	42.0							
							PM <sub>10</sub>	Polk	Mulberry	Anderson & Pine Crest	121050010	14	349	2002	24-hour	357	43	38		150 <sup>a</sup>	28.7
														2003	24-hour	346	51	42		150 <sup>a</sup>	34.0
2004	24-hour	349	66	51		150 <sup>a</sup>								44.0							
2005	24-hour	365	63	61		150 <sup>a</sup>								42.0							
2006	24-hour	253	79	55		150 <sup>a</sup>								52.7							
2002	Annual	357			18	50 <sup>b</sup>								36.0							
2003	Annual	346			20	50 <sup>b</sup>								40.0							
2004	Annual	349			21	50 <sup>b</sup>								42.0							
2005	Annual	365			20	50 <sup>b</sup>								40.0							
2006	Annual	253			21	50 <sup>b</sup>								42.0							
PM <sub>2.5</sub>	Polk	Lakeland	315 Sikes Elementary Scho	121056006	23	358								2002	24-hour	117	30.0	25.5	24.4	35 <sup>a</sup>	69.7
														2003	24-hour	119	22.5	16.5	16.4	35 <sup>a</sup>	46.9
							2004	24-hour	116	32.6	19.9	19.8	35 <sup>a</sup>	56.6							
							2005	24-hour	113	42.0	25.9	21.6	35 <sup>a</sup>	61.7							
							2006	24-hour	117	24.0	19.7	18.3	35 <sup>a</sup>	52.3							
							2002	Annual	117			10.1	15 <sup>b</sup>	67.3							
							2003	Annual	119			9.2	15 <sup>b</sup>	61.3							
							2004	Annual	116			10.2	15 <sup>b</sup>	68.0							
							2005	Annual	113			9.6	15 <sup>b</sup>	64.0							
							2006	Annual	117			9.2	15 <sup>b</sup>	61.3							

8-2

Table 8-1. Polk County Area Ambient Air Quality Data  
 2002 - 2006 Data for PM<sub>10</sub>, PM<sub>2.5</sub>, SO<sub>2</sub>, NO<sub>2</sub>, CO, and Lead

Pollutant	Site Location		Site Name	Site No.	Distance From Site (km)	Direction From Site (Vector °)	Year	Averaging Period	No. of Observations	Ambient Concentration (ug/m <sup>3</sup> )					
	County	City								1st High	2nd High	Arithmetic Mean	Standard	Percent of Standard	
PM <sub>2.5</sub>	Hillsborough	Plant City	North Dover Road	120573002	35	318	2002	24-hour	N/A	N/A	N/A	98 <sup>th</sup> % N/A	35 <sup>a</sup>	N/A	
							2003	24-hour	N/A	N/A	N/A	35 <sup>a</sup>	N/A		
							2004	24-hour	339	36.2	30.8	22.9	35 <sup>a</sup>	35.2	
							2005	24-hour	352	41.0	39.8	25.8	35 <sup>a</sup>	39.7	
							2006	24-hour	355	22.8	22.0	19.2	35 <sup>a</sup>	29.5	
							2006	Annual	N/A			N/A	15 <sup>b</sup>	N/A	
	SO <sub>2</sub>	Polk	Mulberry	Anderson & Pine Crest	121050010	14	349	2002	3-hour	8,612	122.8	96.7		1,300 <sup>c</sup>	9.4
								2003	3-hour	8,282	117.6	88.8		1,300 <sup>c</sup>	9.0
								2004	3-hour	8,514	112.3	104.5		1,300 <sup>c</sup>	8.6
								2005	3-hour	1,579	86.2	60.1		1,300 <sup>c</sup>	6.6
								2006	3-hour	N/A	N/A	N/A		1,300 <sup>c</sup>	N/A
								2006	Annual	N/A					
								2002	24-hour	8,612	28.7	26.1		260 <sup>c</sup>	11.1
								2003	24-hour	8,282	44.4	39.2		260 <sup>c</sup>	17.1
								2004	24-hour	8,514	41.8	36.6		260 <sup>c</sup>	16.1
								2005	24-hour	1,579	23.5	15.7		260 <sup>c</sup>	9.0
								2006	24-hour	N/A	N/A	N/A		260 <sup>c</sup>	N/A
								2006	Annual	N/A					
							2002	Annual	8,612			10.4	60 <sup>b</sup>	17.4	
							2003	Annual	8,282			13.1	60 <sup>b</sup>	21.8	
							2004	Annual	8,514			10.4	60 <sup>b</sup>	17.4	
							2005	Annual	1,579			7.8	60 <sup>b</sup>	13.1	
							2006	Annual	N/A			N/A	60 <sup>b</sup>	N/A	
							2006	Annual	N/A						

Table 8-1. Polk County Area Ambient Air Quality Data  
 2002 - 2006 Data for PM<sub>10</sub>, PM<sub>2.5</sub>, SO<sub>2</sub>, NO<sub>2</sub>, CO, and Lead

Pollutant	Site Location		Site Name	Site No.	Distance From Site (km)	Direction From Site (Vector °)	Year	Averaging Period	No. of Observations	Ambient Concentration (ug/m <sup>3</sup> )				
	County	City								1st High	2nd High	Arithmetic Mean	Standard	Percent of Standard
NO <sub>2</sub>	Hillsborough	Plant City	North Dover Rd	120573002	35	318	2002	Annual	N/A			N/A	100 <sup>b</sup>	N/A
							2003	Annual	N/A			N/A	100 <sup>b</sup>	N/A
							2004	Annual	8,212			13.1	100 <sup>b</sup>	13.1
							2005	Annual	8,584			13.1	100 <sup>b</sup>	13.1
							2006	Annual	8,678			13.1	100 <sup>b</sup>	13.1
CO	Hillsborough	Plant City	One Raider Place	120574004	32	336	2002	1-hour	8,273	3,100	2,700		40,000 <sup>c</sup>	7.8
							2003	1-hour	8,696	2,700	2,500		40,000 <sup>c</sup>	6.8
							2004	1-hour	8,716	2,200	2,100		40,000 <sup>c</sup>	5.5
							2005	1-hour	8,716	2,300	2,200		40,000 <sup>c</sup>	5.8
							2006	1-hour	8,415	3,000	3,000		40,000 <sup>c</sup>	7.5
							2002	8-hour	8,273	1,800	1,600		10,000 <sup>c</sup>	18.0
							2003	8-hour	8,696	1,300	1,300		10,000 <sup>c</sup>	13.0
							2004	8-hour	8,716	1,500	1,500		10,000 <sup>c</sup>	15.0
							2005	8-hour	8,716	1,800	1,700		10,000 <sup>c</sup>	18.0
							2006	8-hour	8,415	2,500	2,200		10,000 <sup>c</sup>	25.0
							Lead	Hillsborough	Tampa	Patent Scaffolding	120571073	47	305	2002
2003	quarterly	58	0.25	0.28		1.5 <sup>b</sup>								16.7
2004	quarterly	56	0.23	0.19		1.5 <sup>b</sup>								15.3
2005	quarterly	61	0.29	0.17		1.5 <sup>b</sup>								19.3
2006	quarterly	58	0.27	0.24		1.5 <sup>b</sup>								18.0

Note: N/A = Not available.

<sup>a</sup> 98th percentile

<sup>b</sup> Arithmetic mean

<sup>c</sup> 2nd highest value

\* Data collected under two methods combined.

\*\* Excluded from attainment/maintenance analysis due to unusual circumstances.

Sources: FDEP, 2007.  
 EPA, 2007.  
 ECT, 2007.

Table 8-2. Polk County Area Ambient Air Quality Data  
2002 - 2006 Data for Ozone

<u>Site Location</u>		Site Name	Site No.	Distance From Site (km)	Direction From Site (Vector °)	Year	Averaging Period	No. of Days	Ambient Ozone Concentration (ug/m <sup>3</sup> )					Percent of Standard
County	City								1st High	2nd High	3rd high	4th high	Standard	
Polk	Lakeland	Sikes Elementary	121056005	23	358	2000	1-hour	242	196	194	192	184	235 <sup>a</sup>	N/C
						2001	1-hour	236	217	214	204	186	235 <sup>a</sup>	N/C
						2002	1-hour	244	174	170	167	163	235 <sup>a</sup>	92.5
						2003	1-hour	239	176	167	161	159	235 <sup>a</sup>	92.5
						2004	1-hour	242	165	163	155	153	235 <sup>a</sup>	75.0
						2005	1-hour	244	188	180	178	172	235 <sup>a</sup>	80.0
						2006	1-hour	245	188	182	174	174	235 <sup>a</sup>	80.0
						2000	8-hour	242	165	163	163	155	157 <sup>b</sup>	N/C
						2001	8-hour	234	180	180	176*	159	157 <sup>b</sup>	N/C
						2002	8-hour	243	145	143	141	141	157 <sup>b</sup>	96.5
						2003	8-hour	237	165	151	147	145	157 <sup>b</sup>	94.4
						2004	8-hour	238	143	141	139	139	157 <sup>b</sup>	90.3
						2005	8-hour	242	151	151	149	145	157 <sup>b</sup>	91.1
						2006	8-hour	244	163	155	151	149	157 <sup>b</sup>	91.9
Polk	Lakeland	Baptist Children's	121056006	33	3	2000	1-hour	222	208	200	186	184	235 <sup>a</sup>	N/C
						2001	1-hour	239	221	208	202	200	235 <sup>a</sup>	N/C
						2002	1-hour	244	180	180	178	174	235 <sup>a</sup>	92.5
						2003	1-hour	245	176	172	170	168	235 <sup>a</sup>	92.5
						2004	1-hour	235	176	172	170	167	235 <sup>a</sup>	76.7
						2005	1-hour	244	194	186	178	176	235 <sup>a</sup>	82.5
						2006	1-hour	245	210	192	192	180	235 <sup>a</sup>	89.2
						2000	8-hour	218	157	155	155	151	157 <sup>b</sup>	N/C
						2001	8-hour	239	192	174	170*	170	157 <sup>b</sup>	N/C
						2002	8-hour	242	149	149	145	141	157 <sup>b</sup>	98.2
						2003	8-hour	243	157	157	153	151	157 <sup>b</sup>	98.2
						2004	8-hour	232	151	145	143	141	157 <sup>b</sup>	91.9
						2005	8-hour	244	167	153	149	147	157 <sup>b</sup>	93.2
						2006	8-hour	243	174	159	159	153	157 <sup>b</sup>	93.6

8-5



Table 8-2. Polk County Area Ambient Air Quality Data  
2002 - 2006 Data for Ozone

Site Location		Site Name	Site No.	Distance From Site (km)	Direction From Site (Vector °)	Year	Averaging Period	No. of Days	Ambient Ozone Concentration (ug/m <sup>3</sup> )					Percent of Standard
County	City								1st High	2nd High	3rd high	4th high	Standard	
Hillsborough	Fort Lonesome	14063 Co. Rd 39	120570110	18	289	2000	1-hour	N/A	N/A	N/A	N/A	N/A	235 <sup>a</sup>	N/A
						2001	1-hour	116	170	163	161	159	235 <sup>a</sup>	N/A
						2002	1-hour	239	186	180	161	159	235 <sup>a</sup>	N/A
						2003	1-hour	241	182	182	180	180	235 <sup>a</sup>	79.2
						2004	1-hour	239	163	161	159	155	235 <sup>a</sup>	79.2
						2005	1-hour	244	190	186	184	176	235 <sup>a</sup>	80.9
						2006	1-hour	241	200	194	190	186	235 <sup>a</sup>	85.0
						2000	8-hour	N/A	N/A	N/A	N/A	N/A	157 <sup>b</sup>	N/A
						2001	8-hour	111	149	147	145	141	157 <sup>b</sup>	N/A
						2002	8-hour	237	147	147	143	139	157 <sup>b</sup>	N/A
						2003	8-hour	240	167	167	157	155	157 <sup>b</sup>	92.3
						2004	8-hour	236	145	143	143	143	157 <sup>b</sup>	92.8
						2005	8-hour	242	159	155	151	151	157 <sup>b</sup>	95.3
						2006	8-hour	239	167	163	159	157	157 <sup>b</sup>	95.7

Note: N/A = Not available  
N/C = Not calculated

<sup>a</sup> Average number of expected exceedances above the standard per year, over a 3-year period, is less than or equal to one.

<sup>b</sup> 4th highest daily 8-hour concentration averaged over a 3-year period.

\* Excluded from attainment/maintenance analysis due to unusual circumstances.

Sources: FDEP, 2007.  
EPA, 2007.  
ECT, 2007.

The results of these analyses were presented in detail in Section 7.0. The following paragraphs summarize the dispersion modeling results as applied to the preconstruction ambient air quality monitoring exemptions.

### **8.2.1 PM<sub>10</sub>**

The maximum 24-hour PM<sub>10</sub> impact was predicted to be 4.9 µg/m<sup>3</sup>. This concentration is below the 24-hour average PM<sub>10</sub> *de minimis* ambient impact level of 10 µg/m<sup>3</sup>. Therefore, Unit 6 qualifies for a preconstruction monitoring exemption for PM<sub>10</sub> in accordance with the FDEP PSD regulations.

### **8.2.2 SO<sub>2</sub>**

The maximum 24-hour SO<sub>2</sub> impact was predicted to be 4.8 µg/m<sup>3</sup>. This concentration is below the 24-hour average SO<sub>2</sub> *de minimis* ambient impact level of 13 µg/m<sup>3</sup>. Therefore, Unit 6 qualifies for a preconstruction monitoring exemption for SO<sub>2</sub> is appropriate in accordance with the FDEP PSD regulations.

### **8.2.3 NO<sub>2</sub>**

The maximum annual NO<sub>2</sub> impact was predicted to be 0.41 µg/m<sup>3</sup>. This concentration is below the annual average NO<sub>2</sub> *de minimis* ambient impact level of 14 µg/m<sup>3</sup>. Therefore, Unit 6 qualifies for a preconstruction monitoring exemption for NO<sub>2</sub> in accordance with the FDEP PSD regulations.

### **8.2.4 CO**

The maximum 8-hour CO impact was predicted to be 13.4 µg/m<sup>3</sup>. This concentration is below the 8-hour average CO *de minimis* ambient impact level of 575 µg/m<sup>3</sup>. Therefore, Unit 6 qualifies for a preconstruction monitoring exemption for CO in accordance with the FDEP PSD regulations.

### 8.2.5 OZONE

Preconstruction monitoring for ozone is required if potential VOC emissions from a project subject to PSD review exceed 100 tpy. Unit 6 potential VOC emissions are 37.9 tpy. Since Unit 6 potential VOC emissions are below the 100-tpy threshold, a preconstruction monitoring exemption is appropriate for ozone in accordance with the FDEP PSD regulations.

## **9.0 ADDITIONAL IMPACT ANALYSIS**

The additional impacts analysis, required for projects subject to PSD review, evaluates project impacts pertaining to associated growth; soils, vegetation, and wildlife; and visibility impairment. Each of these topics is discussed in the following subsections. Based on a thorough review of emissions expected as a result of this project, it is concluded that Unit 6 will not cause any adverse impacts to the soils, vegetation, or wildlife of relevant Class I and II areas.

### **9.1 GROWTH IMPACTS ANALYSIS**

#### **9.1.1 PROJECT GROWTH IMPACTS**

The purpose of the growth impact analysis is to quantify growth resulting from the construction and operation of the proposed project and assess air quality impacts that would result from that growth.

Impacts associated with construction of Unit 6 will be minor. During the approximate 43-month construction period, Tampa Electric will employ an average of 600 workers. While not readily quantifiable, the temporary increase in vehicle miles traveled in the area would be insignificant, as would any temporary increase in vehicular emissions.

Unit 6 is being constructed to meet general area electric power demands; therefore, no significant secondary growth effects due to operation of the Project are anticipated. When operational, Unit 6 is projected to employ approximately 50 fulltime workers. This number of new personnel will not significantly affect growth in the area. The increase in coal, petcoke, and natural gas demand due to the operation of Unit 6 will have no major impact on local fuel markets. No significant air quality impacts due to associated industrial/commercial growth are expected at this time.

#### **9.1.2 AREA GROWTH SINCE 1977**

U.S. Census data shows that the population of the Polk County has increased by approximately 75 percent between 1980 and 2005. The 2005 estimated population of Polk County is 561,606. In 2004, Polk County was ranked as the eighth most populous county

with a population density ranked 19<sup>th</sup> of 67 counties in Florida. Population growth in Polk County had been increasing at a rate slightly slower than for the rest of Florida from 1980 to 2000. In recent years, the rate of population growth in Polk County has exceeded that of the state as a whole. Major Polk County population areas are Lakeland and Bartow. Polk County is projected to have a lower population growth rate than the rest of Florida through 2020.

Although there has been significant population growth in Polk County and Florida over the past 25 years, improvements in motor vehicle emission controls, use of clean transportation fuels, reductions in electric utility emissions due to the ARP, and well-controlled stationary sources have resulted in air quality in Polk County that is currently below the national and Florida AAQS for all pollutants. Data obtained from EPA's Air-Data Web site shows that total Polk County emissions *decreased* by approximately 10 percent over the 11-year period from 1999 through 2001. As evidenced by the Polk County Air Quality Index data, air quality in Polk County has been relatively stable over the past 10 years. There was an average of 336 days per year with good air quality in Polk County over the 5-year period from 2002 to 2006. During 1997, there were 337 days with good air quality.

Accordingly, it is concluded that air quality in Polk County has not deteriorated since 1977. As discussed in Section 7.0, the emissions associated with Unit 6 will result in air quality impacts that are well below the national and Florida AAQS.

## **9.2 IMPACTS ON SOILS, VEGETATION, AND WILDLIFE**

Potential impacts to soils, vegetation, and wildlife resources resulting from Unit 6 operation include the effects of air emissions. Modeled air quality impacts due to Unit 6 for all relevant Class I and II areas are summarized in Table 9-1. In addition, predicted maximum annual nitrogen and sulfur deposition values at the Class I areas of concern are shown in Table 9-2. As previously discussed, Unit 6 will employ state-of-the-art IGCC technology and emission controls. Maximum air quality impacts in the vicinity of Unit 6 will be well below the applicable national and Florida AAQS.

Table 9-1. Unit 6 Maximum Pollutant Concentration Impacts

Pollutant	Averaging Period	Class I Area Impact ( $\mu\text{g}/\text{m}^3$ )		Class II Area Impact ( $\mu\text{g}/\text{m}^3$ )
		Chassahowitzka NWA	Everglades NP	
NO <sub>x</sub>	Annual	0.0040	0.00088	0.55
SO <sub>2</sub>	Annual	0.0047	0.0017	0.45
	24-Hour	0.082	0.045	4.8
	3-Hour	0.33	0.14	15.4
PM <sub>10</sub>	Annual	0.0042	0.0017	0.44
	24-Hour	0.068	0.054	4.9
CO	1-Hour	N/A	N/A	48.4
	8-Hour	N/A	N/A	13.4

Source: ECT, 2007.

Table 9-2. Projected Maximum Annual Wet and Dry Atmospheric Deposition Impacts

Pollutant	Averaging Period	Class I Area Impact (kg/ha/yr)	
		Chassahowitzka NWA	Everglades NP
Total Nitrogen Deposition	Annual	0.0042	0.00092
Total Sulfur Deposition	Annual	0.0077	0.0018

Source: ECT, 2007.

Given the resulting low emission rates and insignificant potential air quality impacts, potential detrimental effects on soils, vegetation, and wildlife will be insignificant.

A general discussion of air emission impacts on soils, vegetation, and wildlife is provided in the following subsection. Following this general discussion, specific analyses of impacts in the vicinity of Unit 6 as well as the two Class I areas located within 300 km (i.e., the Chassahowitzka NWA and Everglades NP) are provided.

### **9.2.1 GENERAL AIR EMISSIONS IMPACTS ON SOILS**

Sulfur and nitrogen can be added to soil as a result of atmospheric deposition. Sulfur and nitrogen deposition in soil can have beneficial effects to vegetation if they are currently lacking these elements. At levels above plant requirements, gaseous emission impacts on soils can cause acidic conditions to develop. Acidic conditions in the soil can cause the leaching of basic cations essential for plant life and in extreme circumstances can transform aluminum to a more soluble form where toxicity can occur (Goldstein *et al.*, 1985).

Nitrogen deficiency is common in nonagricultural areas, and, therefore, much of the atmospherically deposited  $\text{NO}_x$  is biologically assimilated. There is a limited soil adsorption mechanism for nitrate ( $\text{NO}_3$ ), so unutilized nitrate will be leached through the soil (Johnson and Reuss, 1984). Both of these factors indicate that nitrate does not play a significant role in soil acidification, and that sulfate ( $\text{SO}_4$ ) is more of a concern. Atmospheric deposition of nitrogen can facilitate eutrophication of the soil and vegetative community. Critical loads of nitrogen above which eutrophication caused a change in vegetative species present in calcareous forests was found to be 15 to 20 kilograms per hectare per year (kg/ha/yr) (Thimonier *et al.*, 1994).

Sulfur deposition can facilitate soil acidification. Sulfur exists in the soil predominantly in the form of sulfate. The maintenance of sulfate in soil solution facilitates the loss of cations. Therefore, the more sulfate that is adsorbed to soil particles, the more buffered the soils will be (Johnson and Reuss, 1984). The soil is a much larger sink for sulfate than vegetation (Johnson and Reuss, 1984). Sulfate can be adsorbed on the surface of reactive clays and iron/aluminum oxides within the soil, which often releases hydroxide ( $\text{OH}^-$ ),



further buffering the soil (Johnson and Reuss, 1984). Soils found in Florida and Georgia that have high adsorption rates for sulfates include ultisols and certain suborders of inceptisols and entisols (Psamments) (Johnson and Reuss, 1984). The high iron and aluminum content of the subsurface spodic ( $B_h$ ) horizon of spodosols likely adsorbs the sulfate anion to a large extent as is shown to occur with the anion of phosphate. The development of acidic conditions in the Southeast are thought to be well buffered by the high amount of sulfate adsorption (USGS, 1999).

Dissolution of sulfate and nitrate can also facilitate the formation of nitric and  $H_2SO_4$  in rainwater, which increases acidic hydrogen ion ( $H^+$ ) composition within the soil. Soils that are well buffered to the addition of acid causing  $H^+$  ions, have a high cation exchange capacity, often imparted by surface or subsurface clays and a high base saturation. Barton *et al.* (2002) found soils with a base saturation of 12 to 19 percent and reactive clays, to be buffered to acidic inputs, whereas soils with a base saturation of 3 to 7 percent by depth show the effects of soil acidification. In addition, organic horizons of wetland histosols buffer acidic inputs protecting the depletion of cations from the mineral horizons (Koptsik *et al.*, 1998).

### **9.2.2 GENERAL AIR EMISSIONS IMPACTS ON VEGETATION**

It is difficult to predict site-specific ecological impacts due to air emissions based on data and conclusions in available literature because of significant variations in experimental designs relating dose, duration, and vegetation species. Minor variations in experimental design and the conditions under which the various vegetation species have been fumigated can result in large differences in the tolerance limits of tested species.

Table 9-3 presents a summary of the thresholds for the most sensitive vegetation and the air-pollution induced effects, for important air pollution constituents. To demonstrate the range of tolerances for relevant vegetation, Table 9-4 lists literature results for injury threshold concentrations and characteristic injury symptoms of plants found in the southeastern United States. The species listed are likely to occur in all or many of the Class I areas addressed herein. As a result, all listed vegetation will be used as bioindicators for impacts to all the Class I and II areas relevant to the Unit 6 Project.

Table 9-3. Estimated Maximum Facility Impacts Compared to General Plant Injury Symptoms and Threshold Concentrations for Important Air Pollutants

Pollutant	Symptoms	Injury Threshold		Estimated Maximum Facility Impact ( $\mu\text{g}/\text{m}^3$ )
		$\mu\text{g}/\text{m}^3$	Sustainable Exposure	
SO <sub>2</sub>	Bleached spots, intercostal chlorosis	131*	8 hours	15.4†† (3-hour)
SO <sub>2</sub>	Absence of the most sensitive lichen	13-26†	Chronic	
NO <sub>2</sub>	Increase in Nitrate Reductase activity in sensitive bryophytes	65‡	24 hours	0.55†† (annual)
Mercury	Chlorosis and abscission; brown spotting; yellowing of veins	0.08**	5 weeks	1.3 E-06†† (annual)

Note: Conservative (worst-case) impact estimated based on modeling results presented in Section 7.0.

Sources: \*Jones *et al.*, 1974.  
 †Wetmore, 1983.  
 ‡World Health Organization, 2000.  
 \*\*Hindawi, 1970.  
 ††ECT 2007.

Table 9-4. Air Pollutant Injury Threshold Concentrations for Plants Native to the Southeast

Common Name	Scientific Name	SO <sub>2</sub>	NO <sub>x</sub>
Red maple	<i>Acer rubrum</i>	786 <sup>a</sup> (5 hours)	
Maple	<i>Acer</i> sp.	524 to 6,550 <sup>b</sup> (8 hours)	
Bald Cypress	<i>Taxodium distichum</i>	2,620 <sup>c</sup> (48 hours)	
Bracken fern	<i>Pteridium aquilinum</i>	131 to 1,310 <sup>b</sup> (8 hours)	
Blackberry	<i>Rubus</i> sp.	131 to 1,310 <sup>b</sup> (8 hours)	
Ragweeds	<i>Ambrosia</i> sp.	1,310 to 2,620 <sup>h</sup> (1 hour) 790 1,570 (3 hours)	
Southern red oak	<i>Quercus falcata</i>	1,310 to 2,620 <sup>h</sup> (1 hour) 790 to 1,570 (3 hours)	
Black oak	<i>Quercus velutina</i>	1,310 to 2,620 <sup>h</sup> (1 hour) 790 to 1,570 (3 hours)	
Legumes		1,310 to 2,620 <sup>h</sup> (1 hour) 790 to 1,570 (3 hours)	
Locust	<i>Gleditsia</i> sp.	2,620 to 5,240 <sup>h</sup> (1 hour) 1,570 to 2,100 (3 hours)	
Many crop and garden species		2,620 to 5,240 <sup>h</sup> (1 hour) 1,570 to 2,100 (3 hours)	
American elm	<i>Ulmus americana</i>	131 to 1,310 <sup>b</sup> (8 hours)	
White ash	<i>Fraxinus americana</i>	131 to 1,310 <sup>b</sup> (8 hours)	
Sumacs	<i>Rhus</i> spp.	131 to 1,310 <sup>b</sup> (8 hours)	
Tulip poplar	<i>Liriodendron tulipifera</i>	524 to 6,550 <sup>b</sup> (8 hours)	
Sweetgum	<i>Liquidambar styraciflua</i>	524 to 6,550 <sup>b</sup> (8 hours)	
Slash pine	<i>Pinus elliotii</i>	149 <sup>f</sup> (chronic)	
Basswood	<i>Tilia glabra</i> = <i>T. americana</i>	524 to 6,550 <sup>b</sup> (8 hours)	
Pin oak	<i>Quercus palustris</i>	524 to 6,550 <sup>b</sup> (8 hours)	
Red cedar	<i>Juniperus virginiana</i>	>5,240 <sup>b</sup> (8 hours)	
Potato		2,620 to 5,240 <sup>h</sup> (1 hour) 1,570 to 2,100 (3 hours)	

Table 9-4. Air Pollutant Injury Threshold Concentrations for Plants Native to the Southeast (Continued, Page 2 of 2)

Common Name	Scientific Name	SO <sub>2</sub>	NO <sub>x</sub>
Upland cotton	<i>Gossypium hirsutum</i>	>5,240 <sup>h</sup> (1 hour) >2,100 (3 hours)	
Corn	<i>Zea mays</i>	>5,240 <sup>h</sup> (1 hour) >2,100 (3 hours)	
Lichen	<i>Ramalina americana</i>	13 to 26 <sup>d</sup> (chronic)	
Lichens	Sensitive species of <i>Usnea</i> , <i>Lobaria</i> , <i>Cladonia</i>	>30 <sup>e</sup> (chronic)	
White oak	<i>Quercus alba</i>	>5,240 <sup>b</sup> (8 hours)	
Dogwood	<i>Cornus florida</i>	>5,240 <sup>b</sup> (8 hours)	
Bryophyte	Several Bryophyte species		65 <sup>g</sup> (24 hours)
Birch	<i>Betula</i> sp.		120 <sup>g</sup> (chronic)
Common sunflower	<i>Helianthus annuus</i>		375 <sup>g</sup> (chronic)
Alfalfa	<i>Medicago sativa</i>		1,000 <sup>g</sup> (5 hours)
Peach	<i>Prunus persica</i>		>5,240 (1 hour) >2,100 (3 hours)
Garden pea	<i>Pisum sativum</i>		850 <sup>g</sup> (7 hours)
Cultivated tobacco	<i>Nicotiana tabacum</i>		2,000 to 3,000 <sup>g</sup> (3.5 hours)
Perennial ryegrass	<i>Lolium perenne</i>		125 <sup>g</sup> (chronic)
Southern pine	<i>Pinus</i> spp.	1572 <sup>b</sup> (3 hours)	

Note: Concentrations in µg/m<sup>3</sup> (exposure times shown in parentheses).

Sources: <sup>a</sup>Davis and Shelly, 1992.

<sup>b</sup>Jones *et al.*, 1974.

<sup>c</sup>Shanklin and Kozlowski, 1985.

<sup>d</sup>Wetmore, 1983.

<sup>e</sup>Treshow and Anderson, 1989.

<sup>f</sup>Hogsett *et al.*, 1985.

<sup>g</sup>World Health Organization, 2000.

<sup>h</sup>EPA, 1982.

Vegetation damage is described as impacts resulting in foliar damage. Less apparent vegetation injury is described as a reduction in growth and/or productivity without visible damage, as well as changes in secondary metabolites such as tannins and phenolic compounds (Fitzgerald *et al.*, 1996). Vegetation damage often results from acute exposure to pollution (i.e., relatively high doses over relatively short time periods). Injury is also associated with prolonged exposures of vegetation to relatively low doses of pollutants (chronic exposure). Acute damages, which have both functional and visible consequences, are usually manifested by internal physical damage to foliar tissues. Chronic injuries are typically more associated with changes in physiological processes. The following discussion summarizes descriptions from the literature of the potential effects upon vegetation associated with the relevant pollutants.

#### **9.2.2.1 Nitrogen Oxides**

During combustion, atmospheric nitrogen is oxidized to NO<sub>x</sub> and small amounts of NO<sub>2</sub> (Taylor *et al.*, 1975). Impacts to vegetation from NO<sub>2</sub> result from high concentrations occurring during short time periods (Taylor and MacLean, 1970). Acute exposures of this sort will cause necrotic lesions in leaf tissue and excessive defoliation (MacLean *et al.*, 1968). Non-vascular bryophytes are very sensitive to NO<sub>x</sub> exhibiting reductions in nitrate reductase activity at concentrations of 65 µg/m<sup>3</sup> with an exposure duration of 24 hours (WHO 2000). Bald cypress (*Taxodium distichum*), a common tree species in wetlands of this geographical area, shows no adverse impacts below 2,620 µg/m<sup>3</sup> with an exposure time of 48 hours (Shanklin and Kozlowski, 1985).

#### **9.2.2.2 Sulfur Dioxide**

Natural (ambient) background concentrations of SO<sub>2</sub> range between 0.28 and 2.8 µg/m<sup>3</sup> on a mean annual basis (Prinz and Brandt, 1985). The most common source of atmospheric SO<sub>2</sub> is the combustion of fossil fuels (Mudd and Kozlowski, 1975). Gaseous SO<sub>2</sub> primarily affects vegetation by diffusion through the stomata (Varshney and Garg, 1979). Small amounts of SO<sub>2</sub> may also be absorbed through the protective cuticle. At low concentrations SO<sub>2</sub> byproducts are effectively detoxified by the plant and can become a sulfur source to the plant, while elevated concentrations can be toxic (Zeiger, 2002). Adverse effects on plants from SO<sub>2</sub> are primarily due to impacts to photosynthetic processes.

SO<sub>2</sub> can react with chlorophyll by bleaching or phaeophytinization. This latter process constitutes a photosynthetic deactivation of the chlorophyll molecule. Acute damage due to SO<sub>2</sub> appears as marginal or intercostal areas of dead tissue that at first cause leaves to appear water-soaked (Barett and Benedict, 1970). Chronic injuries are less apparent; the leaves remain turgid and continue to function at a reduced level. In more severe cases of chronic SO<sub>2</sub> exposure, there is some bleaching of the chlorophyll that appears as a mild chlorosis or yellowing of the leaf and/or a silvery or bronzing of the undersurface. Species that are categorized as sensitive to SO<sub>2</sub> emissions are those which show damage to at least 5 percent of the leaf area upon being exposed to 131 to 1,310 µg/m<sup>3</sup> SO<sub>2</sub> for a period of 8 hours (Jones *et al.*, 1974).

Researchers have conducted numerous studies to determine the effects of SO<sub>2</sub> exposure to a wide variety of selected plant species. A review of the literature demonstrates that the most sensitive vascular plants (e.g., white ash, sumacs, tulip poplar, goldenrods [*Solidago* spp.], legumes, blackberry [*Rubus* spp.], black oak [*Quercus velutina*], and ragweeds [*Ambrosia* spp.]) exhibit visible injury to short-term (3 hours) exposure to SO<sub>2</sub> concentrations ranging from 790 to 1,570 µg/m<sup>3</sup>. Tolerant plants native to the southeast region are dogwood (*Cornus florida*), red cedar (*Juniperus virginiana*), and white oak (*Quercus alba*) with injury thresholds greater than 5,240 µg/m<sup>3</sup> for a 3-hour exposure period (Jones *et al.*, 1974). Plants with intermediate tolerance (131 to 1,310 µg/m<sup>3</sup> for an 8-hour period) are maples (*Acer* spp.), tulip poplar (*Liriodendron tulipifera*), and sweetgum (*Liquidambar styraciflua*). Vascular plant species found in this region of the southeast, which are sensitive or moderately sensitive to SO<sub>2</sub>, include bracken fern (*Pteridium aquilinum*), blackberry, sumacs (*Rhus* spp.), and tulip poplar. Complicating generalizations regarding SO<sub>2</sub> injury is the observation that the genetic variability of native annual plants can result in the selection of SO<sub>2</sub> resistant strains in as little as 25 years (Westman *et al.*, 1985).

Due to their rather diminutive and inconspicuous nature, lichens and bryophytes are often not considered as important biological components of the ecosystem. However, these nonvascular plants do play a valid role in the environment by functioning as habitat for invertebrates, containing blue-green bacteria that fix nitrogen, participating in mineral cycling, and providing a food source for various fauna, among others.

Nonvascular plants such as lichens and bryophytes are especially important as bioindicators due to well-documented air pollution sensitivity. Because of relatively low chlorophyll content and the absence of the protective covering of a cuticle (common in the leaves of higher plants), nonvascular plants are more sensitive to SO<sub>2</sub> injury. Hart *et al.* (1988) showed that *Ramalina* sp., a lichen genus, exhibited a reduction of CO<sub>2</sub> uptake and biomass gain at SO<sub>2</sub> exposures of 400 µg/m<sup>3</sup> for 6 weeks. Tolerant lichens can resist SO<sub>2</sub> concentrations in the range of 79 to 157 µg/m<sup>3</sup>; higher concentrations are deleterious to most nonvascular flora (LeBlanc and Rao, 1975). A mean annual concentration of 30 µg/m<sup>3</sup> of SO<sub>2</sub> may injure sensitive individuals of some lichen species such as *Usnea*, *Lobaria*, *Ramalina*, and *Cladonia* (Treshow and Anderson, 1989). One lichen species, *Ramalina americana*, is known to be absent where SO<sub>2</sub> concentration mean annual values range from 13 to 26 µg/m<sup>3</sup> (LeBlanc and Rao, 1972; Wetmore, 1983).

### 9.2.2.3 Particulate Matter

In addition to gaseous emissions, minor amounts of PM will be emitted by the proposed Unit 6 Project. Typically, the density of PM limits impacts such that only vegetation in proximity to the source will be affected.

Included among the PM may be low concentrations of mercury, beryllium, arsenic, and lead, to the extent present at low levels in the gasifier feedstocks. The mercury may occur as both mercury vapors and particulates. The mechanism of mercury phytotoxicity is currently under investigation. Past investigations indicate that mercury vapors will cause chlorosis, abscission of older leaves, growth reduction, and poor development. Most investigations have been restricted to greenhouse crops where air quality monitoring was not conducted. One investigation indicates that vegetation exposed to 50 µg/m<sup>3</sup> mercury for 7 days experienced leaf abscission (Siegel *et al.*, 1984). Plants found in the region showing injury at this concentration and period of exposure to mercury are willow (*Salix* spp.) and red maple (*Acer rubrum*).

The literature regarding effects on vegetation from beryllium, arsenic, and lead is scarce. One investigation indicates that vegetation growth was reduced by beryllium concentra-

tions in excess of 735  $\mu\text{g}/\text{m}^3$  (Gough *et al.*, 1979). Arsenic uptake by vegetation to a concentration of 5 micrograms per gram ( $\mu\text{g}/\text{g}$ ) is considered harmful. Lead retards plant growth above a concentration of 30  $\mu\text{g}/\text{g}$  in the soil.

#### **9.2.2.4 Carbon Monoxide**

CO is not considered harmful to plants and is not known to be effectively taken up by plants (Bennett and Hill, 1975). Microorganisms within the soil appear to be a major sink for CO.

### **9.2.3 GENERAL AIR EMISSIONS IMPACTS ON WILDLIFE**

Impacts to wildlife can occur due to direct uptake of pollutants through ingestion or via the skin and more indirectly as a result of air pollution induced changes to wildlife habitat and food source. Studies have shown direct air pollution induced injury and death in wildlife as a result of fluoride, cadmium,  $\text{SO}_2$ , particulates,  $\text{NO}_x$ , arsenic, mercury, and oxidants like ozone (Newman 1980; Newman & Schreiber 1985). These impacts are mostly the result of extreme incidences due to acute toxicity. This acute toxicity occurs most severely in circumstances where air pollutants were likely elevated far above the AAQS, or where significantly elevated concentrations of pollutants occurred on vegetation that was subsequently consumed. The national and Florida AAQS were previously shown in Section 3.0 on Table 3-1. Physiological and behavioral effects have not been observed at concentrations at or below the AAQS. No observed impacts upon wildlife are expected at concentrations below the values reported in Table 9-5.

Studies have shown damage to the tracheal epithelium of bird species at extreme concentrations of  $\text{NO}_x$  and  $\text{SO}_2$  of 2,500  $\mu\text{g}/\text{m}^3$  and 1,221  $\mu\text{g}/\text{m}^3$ , respectively (Llacuna *et al.* 1993). These values are far elevated above concentrations that are expected.

Ambient air quality concentrations as a result of Unit 6 will not exceed the national and Florida AAQS or the values listed in Table 9-5. Pollutant deposition on vegetation at levels harmful to wildlife will likely be lower than plant injury thresholds previously shown in Tables 9-3 and 9-4. Absent any site-specific studies on baseline levels of pollutants, it



Table 9-5. Examples of Reported Stresses to Animals at Air Pollutant Concentrations Below National Secondary Ambient Air Quality Standards

Pollutant	Reported Effect	Concentration ( $\mu\text{g}/\text{m}^3$ )	Exposure
SO <sub>2</sub> *	Respiratory stress in guinea pigs	427 to 854	1 hour
	Respiratory stress in rats	267	7 hours/day; 5 days/week for 10 weeks continually for 5 months
	Decreased abundance in deer mice	13 to 157	
NO <sub>x</sub> †‡	Respiratory stress in mice	1,917	3 hours
	Respiratory stress in guinea pigs	96 to 958	8 hours/day for 122 days continually for 2 months
Particulates*	Respiratory stress, reduced respiratory disease defenses	120 PbO <sub>3</sub>	2 hours
	Decreased respiratory disease defenses in rats, same with hamsters	100 NiCl <sub>2</sub>	

Sources: \*Newman and Schreiber, 1988.

†Gardner and Graham, 1976.

‡Trzeciak et al., 1977.

is assumed that wildlife impacts will be insignificant if pollutant effects on vegetation are also expected to be insignificant.

Persistent pollutants such as mercury have the potential to collect in the environment and bioaccumulate to elevated concentrations in upper-trophic level wildlife. Mercury is a persistent pollutant that accumulates in the sediments. Mercury methylation, whereby inorganic forms of mercury are biologically converted to a bioavailable organic form, occurs most predominantly in the anaerobic conditions found in ponds, lakes, and wetlands (St. Louis *et al.*, 1994; Krabbenhoft *et al.*, 1995; Driscoll *et al.*, 1998). As a result, species living and feeding within these aquatic systems are the most sensitive to mercury bioaccumulation.

Most impacts to wildlife due to emissions from power plants are indirect, predominantly as a result of effects on habitat quality. One such indirect effect is increased acidification. Amphibians are particularly sensitive to increased acidification in vernal pools and ponds as a result of the permeability of their skin. The highest potential for acidification to impact amphibian egg-laying habitat occurs in snow-melt water pools, which do not occur in the Project area (Schreiber and Newman, 1988). Loss of fish, amphibians, algae, invertebrates, and vegetative habitat as a result of acidification can impact species further up the food chain such as fish-eating feral mink (Bevanger and Albu, 1986) and wetland waterfowl (Rattner *et al.*, 1987). These studies indicate that the greatest possible impact to wildlife as a whole is degradation of the composition, structure, and habitat value due to increased acidification of the soils and aquatic systems caused by elevated SO<sub>x</sub> and NO<sub>x</sub>. As discussed in subsequent sections, the atmospheric concentrations of SO<sub>x</sub> and NO<sub>x</sub> and deposition of sulfur and nitrogenous compounds as a result of Unit 6 are unlikely to cause soil and water acidification.

#### **9.2.4 SPECIFIC AIR EMISSIONS IMPACTS IN THE VICINITY OF UNIT 6**

Unit 6 air quality impacts on soils, vegetation, and wildlife in the vicinity of the PPS will be insignificant. Maximum Unit 6 Class II impacts are projected to be well below the national and Florida AAQS. Maximum Unit 6 annual average NO<sub>2</sub>, SO<sub>2</sub>, and PM<sub>10</sub> impacts are only 0.6, 0.8, and 0.9 percent of the annual average AAQS, respectively. Maximum

Unit 6 24-hour average SO<sub>2</sub> and PM<sub>10</sub> impacts are only 1.9 and 3.3 percent of the 24-hour average AAQS, respectively.

### **9.2.5 SPECIFIC AIR EMISSIONS IMPACTS—CLASS I AREAS**

The following describes environmental features and a discussion of potential impacts to Class I areas located within 300 km of the proposed Project Site as a result of Unit 6 emissions. The two Class I areas within this range are the Chassahowitzka NWA and the Everglades NP. This portion of the analysis will focus on the potential impacts to AQRVs within these public lands. AQRVs are defined as:

“All those values possessed by an area except those that are not affected by changes in air quality and include all those assets of an area whose vitality, significance, or integrity is dependent in some way upon the air environment. The values include visibility and those scenic cultural, biological, and recreational resources of an area that are affected by air quality. Important attributes of an area are those values or assets that make an area significant as a national monument, preserve, or primitive area. They are assets that are to be preserved if the area is to achieve the purposes for which it was set aside” (Federal Register, 1978).

The following sections address Unit 6 air quality impacts on vegetation, wildlife, and soils at the Chassahowitzka NWA and the Everglades NP. Unit 6 is located 117 km from the Chassahowitzka NWA and 211 km from the Everglades NP. Due to the much greater distance to the Everglades NP, Unit 6 impacts are much lower at this Class I area. Accordingly, Unit 6 impacts at the Chassahowitzka NWA are the primary focus of the additional impact analysis.

#### **9.2.5.1 Chassahowitzka NWA**

##### **Vegetation Types**

The predominant vegetative communities that are represented in the Chassahowitzka NWA include hardwood swamps, cypress ponds, flatwoods, saltmarsh, sandhill, scrub, and wet prairies (FWC, 2001).

##### **Hardwood Swamp**

The hardwood swamp is the most prevalent vegetative community in the Chassahowitzka NWA. This community is a palustrine wetland community characterized by the diverse

mixture of trees, shrubs, and vines that vary with the differences in elevation. Dominant tree species include bald cypress (*Taxodium distichum*), red maple (*Acer rubrum*), sweet gum (*Liquidambar styraciflua*), winged elm (*Ulmus alata*), southern magnolia (*Magnolia grandiflora*), ashes (*Fraxinus* spp.), and southern red cedar (*Juniperus silicicola*). The subcanopy includes redbud (*Cercis canadensis*) and basswood (*Tilia* spp.) in higher elevation sites and red bay (*Persea borbonia*), swamp dogwood (*Cornus foemina*), and dahoon holly (*Ilex cassine*) in lower elevations. The understory vegetation consists of dwarf palmetto (*Sabal minor*), American beautyberry (*Callicarpa americana*), and grape vines (*Vitis* spp.) in higher elevations, while wax myrtle (*Myrica cerifera*), dewberry (*Rubus* spp.), and various ferns are found in lower elevations. The vegetative community provides a good source of mast for numerous wildlife species and plentiful habitat.

### **Cypress Pond**

Cypress ponds are found in depressions throughout the uplands. The vegetative community consists of pond cypress (*Taxodium ascendens*), bald cypress, red maple, sweet gum, Virginia willow (*Itea virginica*), and buttonbush (*Cephalanthus occidentalis*).

### **Flatwoods**

Flatwoods are often located in regions with unproductive soils with low water available to the vegetation. The plant community consists largely of longleaf pine (*Pinus palustris*) or slash pine (*P. elliotii*) with an understory consisting of saw palmetto (*Serenoa repens*) wax myrtle, and gallberry (*Ilex glabra*). The quality of this community for wildlife utilization appears to be poor as a result of historic fire suppression.

### **Sandhills**

Xeric conditions brought on by sandy soils define the sparse vegetative community of the sandhills. The tree canopy consists of longleaf pine, sand pine (*Pinus clausa*), blackjack oak (*Q. incana*), and turkey oak (*Quercus laevis*) with wiregrass (*Aristida stricta*), palmettos, and various herbs in the understory.

### **Saltmarsh**

The saltmarsh community occurs from the Gulf of Mexico in to the tidal creeks with the vegetative community transitioning from black needle rush (*Juncus roemerianus*) and smooth cordgrass (*Spartina alterniflora*) in the high salinity portions to sawgrass (*Cladium jamaicense*) in the fresher portions. Upland islands consist of red cedar, cabbage palm, and live oaks.

### **Scrub**

The scrub community occurs on north-south strands occurring along prehistoric dunes. Scrub communities consist of sand pine, myrtle oak (*Q. myrtifolia*), and scrub live oak (*Q. geminata*).

### **Wet Prairie**

Wet prairies occur scattered throughout the sandhills. They are dominated by marsh species including white-tops (*Dichromena colorata*), spikerushes (*Eleocharis* spp.), bog buttons (*Lachnocaulon anceps*), dahoon holly, American lotus (*Nelumbo lutea*), and spatterdock (*Nuphar lutea*).

### **Vegetation Impact Analysis**

Monitoring stations are spread throughout the region at different distances from Chassahowitzka NWA. Nonetheless, these measurements can be illustrative of baseline conditions at Chassahowitzka NWA. The NO<sub>2</sub> concentration at St. Petersburg remains stable at approximately one-fifth of the national annual standard of 0.053 ppm (100 µg/m<sup>3</sup>). As a result of the Unit 6 Project, maximum NO<sub>2</sub> concentrations are projected to increase annually by only 0.0040 µg/m<sup>3</sup> as shown in Table 9-1. This increase is a small fraction of levels known to cause harm to the most sensitive vegetation (65 µg/m<sup>3</sup> for 24 hours) shown in Table 9-3. Currently, SO<sub>2</sub> at the Tampa-St. Petersburg-Clearwater sites are well below the annual Florida AAQS of 60 µg/m<sup>3</sup>. A maximum SO<sub>2</sub> increase in 3-hour, 24-hour, and annual concentrations of 0.33, 0.082, and 0.0047 µg/m<sup>3</sup>, respectively, as a result of Unit 6 operations will not impact the most sensitive vegetation with tolerances of 131 µg/m<sup>3</sup> for 8 hours and 13 µg/m<sup>3</sup> for chronic exposures indicated in Table 9-4. The SO<sub>2</sub> concentra-

tion increase as a result of the Unit 6 Project will produce a negligible increase in concentrations with respect to vegetative impacts.

PM<sub>10</sub> concentrations in the St. Petersburg-Tampa-Clearwater area remain well below the annual average Florida AAQS of 50 µg/m<sup>3</sup>. The impact from the small maximum annual and 24-hour PM<sub>10</sub> increases of 0.0042 and 0.068 µg/m<sup>3</sup>, respectively, as a result of the Unit 6 Project, are negligible with regard to ecosystem impacts within the Chassahowitzka NWA.

### **Typical Wildlife**

The diverse array of communities and the close association between wetlands and uplands allows for a wide array of wildlife species. Many species of wildlife that are endangered, threatened, or species of special concern are present in the Chassahowitzka NWA including the Florida black bear, Florida mouse, gopher tortoise, Eastern indigo snake, Florida gopher frog, American alligator, Florida pine snake, and potentially bald eagles. The heterogeneous composition of the aquatic communities and range of salinities allows for a large diversity of fish species typical of this region of Florida.

Whooping crane populations have recently been established to winter in the Chassahowitzka NWA. In addition, along their migratory pathway, they have been known to occur near the Tampa electric Site. This is a sensitive species brought back from the brink of extinction. On their wintering grounds, the whooping crane prefers a habitat within estuarine marshes, shallow bays, and salt tidal flats and can be found within freshwater wetlands along their migration path. They prefer to feed on crabs, shrimps, clams, snails, frogs, snakes, grasshoppers, larval and nymph forms of flies, beetles, water bugs, birds, and small mammals. In addition, they have been known to eat more than 58 species of fish.

### **Wildlife Impact Evaluation**

Air pollutant concentrations in the vicinity of Unit 6 are projected to be well below national and Florida AAQS and the minimum threshold concentrations shown in Table 9-5, below which no wildlife acute toxicity is expected to occur. Most air pollution effects on

wildlife are indirect, predominantly as a result of decreased habitat quality. As discussed above, minimal impacts to vegetation are expected to occur as a result of the low emissions increases in CNWR. Therefore, no adverse impacts to wildlife are expected due to the Unit 6 Project.

Due to the fact that the cranes are a carnivorous species, predominantly feeding in wetlands, (where mercury methylation is accelerated) there is a potential for biomagnification of mercury. Mercury deposition is monitored at CNWR as part of the Mercury Deposition Program (MDP). Annual average wet deposition values of mercury at the MDP monitoring station range from 0.3 to 0.5 kg/ha/yr as shown in Figure 9-1. These values are within the lower end of the range of reported background mercury deposition rates of 0.5 and 1  $\mu\text{g}/\text{m}^2 \text{ yr}^{-1}$  (Bindler, 2003). No studies have been found that determine the impact of mercury deposition on the Chassahowitzka NWA ecosystem, but these deposition levels are roughly equivalent to deposition occurring in Okefenokee NWA, where mercury has been found at high levels in fish tissue, as discussed previously.

The mercury wet deposition rate as a result of Unit 6 (0.07  $\mu\text{g}/\text{m}^2/\text{yr}$  maxima) in the vicinity of Unit 6 is an order of magnitude lower than conservative natural background deposition estimates (0.5 to 1  $\mu\text{g}/\text{m}^2/\text{yr}$ ) (Bindler 2003). It is safe to assume that mercury deposition at the distant CNWR will be much lower than the small amount emitted in the vicinity of Unit 6, where it was deemed that no wildlife impacts are projected to occur. Therefore, it is unlikely that whooping cranes will be significantly affected by mercury along their migratory pathway or in their wintering grounds in the Chassahowitzka NWA as a result of the Unit 6 Project.

Migratory birds spending time in freshwater wetlands can be affected by acidification (Longcore, Ross, and Fischer, 1987). Reproductive success of birds with a variety of feeding habits has declined as a result of acidification-induced reductions in food abundance (Blancher and McAuley, 1987). Due to the low emissions discussed throughout these sections, which have been shown to be below levels causing significant acidity, it is unlikely that the whooping crane will be affected.

### **Soil Characteristics**

Soil types within the Chassahowitzka NWA are listed in the conceptual management plan (FWS, 2001). NRCS/USDA soil surveys were utilized to compile the soil pH data provided in Table 9-6, and the relevant soil chemical properties for all the soils shown in Table 9-7. Soils found in the Chassahowitzka NWA range from very poorly drained organic soils (Aripeka-Okeelanta-Lauderhill and Okeelanta-Terra Ceia) in the freshwater wetlands and saltwater marshes to excessively drained sandy soils in the sandhills (Candler fine sand). The dominant soils are histosols and the psamment subgroup of the series entisols.

### **Soils Impacts Evaluation**

Dominant soil types (histosols, psamment entisols) have a high sulfate adsorption capacity, increasing buffering to changes in pH (Johnson and Reuss, 1984). Base saturation of the soils of the Chassahowitzka NWA tends to be high, even in surface horizons, further indicating a strong buffering capacity. The Astatula soil has a low base saturation, but it comprises only 0.15 percent of the refuge.

Soil acidification and eutrophication and other effects can occur as a result of atmospheric deposition of  $\text{NO}_x$  and  $\text{SO}_x$ . Atmospheric deposition is monitored at the Chassahowitzka NWA as part of the National Atmospheric Deposition Program (NADP). Annual averages for wet deposition of nitrate and sulfate are shown in Figures 9-1 and 9-2, respectively. NADP monitoring of average annual nitrate wet deposition values range between approximately 7 to 10 kg/ha/yr as shown in Figure 9-2. These deposition values are below the threshold (15 to 20 hg/ha/yr) where eutrophication has been observed in calcareous forests (Thimonier *et al.*, 1994). Maximum atmospheric total deposition of nitrogen is projected to increase by 0.0042 kg/ha/yr as a result of Unit 6, which would cause no measurable eutrophication of the Chassahowitzka NWA. As shown in Figure 9-3, average annual sulfite wet deposition values range between approximately 13 to 16 kg/ha/yr. The dominant soil types of the refuge are well buffered to sulfate deposition. Regardless, sulfur total atmospheric deposition will only increase at a maximum of 0.0077 kg/ha/yr within the Chassahowitzka NWA as a result of the Unit 6 Project.



Table 9-6. Soil pHs for the Soils Found in the Chassahowitzka NWA

Soil	Depth (inches)	Soil Reaction (pH)
Adamsville-fine sand	0 to 80	4.5 to 7.8
Anclote fine sand	0 to 80	5.1 to 8.4
Aripeka fine sand	0 to 13	5.6 to 7.8
	13 to 21	6.6 to 8.4
Aripeka - Okeelanta - Lauderdale		
Okeelanta	0 to 27	5.1 to 6.5
	27 to 60	5.1 to 7.3
Lauderhill	0 to 80	6.1 to 8.4
Astatula fine sand	0 to 80	4.5 to 6.5
Basinger fine sand	0 to 8	3.6 to 8.4
	8 to 60	3.6 to 7.3
Basinger fine sand, depressional	0 to 80	3.6 to 7.3
Candler fine sand	0 to 80	4.5 to 6.0
EauGallie fine sand	0 to 25	4.5 to 6.0
	25 to 33	4.5 to 6.5
	33 to 57	5.1 to 7.8
	57 to 63	5.1 to 7.8
Homosassa mucky fine sandy loam	0 to 80	6.1 to 7.8
Lacoochee fine sandy loam	0 to 8	7.9 to 8.4
	8 to 13	6.6 to 8.4
Myakka fine sand	0 to 80	3.6 to 6.5
Okeelanta - Terra Ceia		
Okeelanta	0 to 27	4.5 to 7.8
	27 to 60	5.1 to 7.8
Terra Ceia	0 to 80	5.6 to 8.4
Paola fine sand	0 to 80	3.6 to 7.3
Pomello fine sand	0 to 80	4.5 to 6.0
Tavares fine sand	0 to 80	4.5 to 6.0
Weekiwachee muck	0 to 80	6.1 to 7.8
Weekiwachee – Homosassa	0 to 80	6.1 to 7.8

Source: USDA, NRCS soil surveys of Citrus County, 1988 and Hernando County, 1977.

Table 9-7. Chemical Properties of the Soils within the Chassahowitzka NWA

Soil	Depth (cm)	Horizon	Cadmium	Magnesium	Sodium	Potassium	CEC	Base Saturation
Adamsville-fine sand	0 to 18	Ap	1.19	0.27	0.02	0.13	5.04	32
	18 to 51	C1	0.2	0.07	0.01	0.03	1.36	23
	51 to 99	C2	0.12	0.05	0.01	0.01	0.72	26
	99 to 152	C3	0.04	0.04	0.02	0	0.4	25
	152 to 203	C3	0.06	0.02	0.01	0	0.24	38
Aripeka fine sand	0 to 8	A1	3.1	1.6	0	0.1	7.8	62
	8 to 13	A2	1.2	0.6	0	0.1	4	48
	13 to 25	B21	0.4	0.3	0.1	0	1.8	44
	25 to 33	B22	1.4	0.5	0.1	0	3	67
	33 to 38	B23t	7.7	1.5	0.8	0.2	14.1	72
	38 to 53	B24t	10.8	1	1.6	0.2	15.8	86
Astatula fine sand	0 to 13	A	0.11	0.04	0.02	0.02	2.4	8
	13 to 46	C1	0.03	0.01	0.02	0.01	1.74	4
	46 to 119	C2	0.02	0.01	0.01	0	0.78	5
	119 to 203	C3	0.02	0.01	0.01	0	0.68	6
Candler fine sand	0 to 10	A	0.18	0.05	0.01	0.01	3.02	8
	10 to 36	E1	0.03	0.02	0.01	0.01	1.5	5
	36 to 89	E2	0.03	0.02	0.01	0	0.61	10
	89 to 132	E3	0.01	0.02	0.01	0	0.45	9
	132 to 183	E4	0.02	0.02	0.01	0	0.24	21
	183 to 203	E/Bt	0.02	0.03	0.01	0	0.4	15

9-23

Table 9-7. Chemical Properties of the Soils within the Chassahowitzka NWA (Continued, Page 2 of 2)

Soil	Depth (cm)	Horizon	Cadmium	Magnesium	Sodium	Potassium	CEC	Base Saturation
EauGallie fine sand	0 to 8	A1	4.8	3.36	0.12	0.13	19.91	42
	8 to 25	A2	0.51	0.56	0.04	0.03	4.19	27
	25 to 56	E	0.05	0.03	0.02	0	0.55	18
	56 to 114	Bh1	0.15	0.18	0.07	0	19.3	2
	114 to 135	Bh2	0.24	0.05	0.05	0	9.57	4
	135 to 173	Btg1	2.53	0.48	0.11	0.14	12.66	26
	173 to 203	Btg2	3.8	0.48	0.09	0.14	11.87	38
Myakka fine sand	0 to 10	A	2.46	2.33	0.11	0.05	14.64	34
	10 to 25	E1	1.13	0.89	0.08	0.02	6.75	31
	25 to 68	E2	0.05	0.03	0.02	0	0.18	56
	68 to 107	Bh1	0.12	0.04	0.05	0	14.46	1
	107 to 140	Bh2	0.24	0.04	0.05	0	10.99	3
	140 to 170	BC	0.49	0.05	0.03	0	5.94	10
	170 to 203	Bh'	4.35	0.08	0.08	0.01	9.23	49
Tavares fine sand	0 to 8	A	0.64	0.16	0.01	0.03	3.16	27
	8 to 56	C1	0.04	0.02	0.01	0.01	1.35	6
	56 to 104	C1	0.02	0.01	0	0	0.96	3
	104 to 160	C2	0.03	0.02	0.02	0	0.37	19
	160 to 203	C3	0.02	0.01	0.01	0	0.14	29

9-24

Source: USDA, NRCS soil surveys of Citrus County, 1988 and Hernando County, 1977.

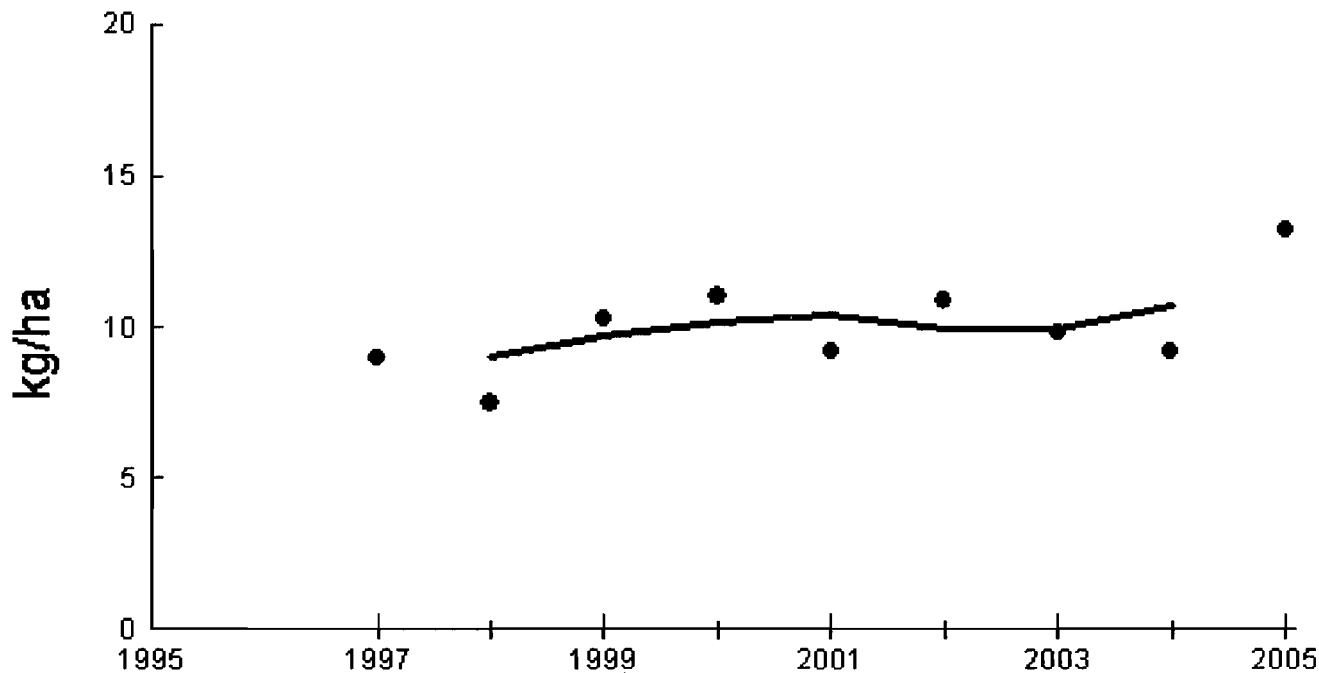

FIGURE 9-1.  
 NADP ANNUAL WET DEPOSITION VALUES AND  
 3-YEAR WEIGHTED AVERAGE TRENDLINE FOR  
 NITRATE WITHIN THE CHASSAHOWITZKA NWA  
 Source: ECT, 2007.



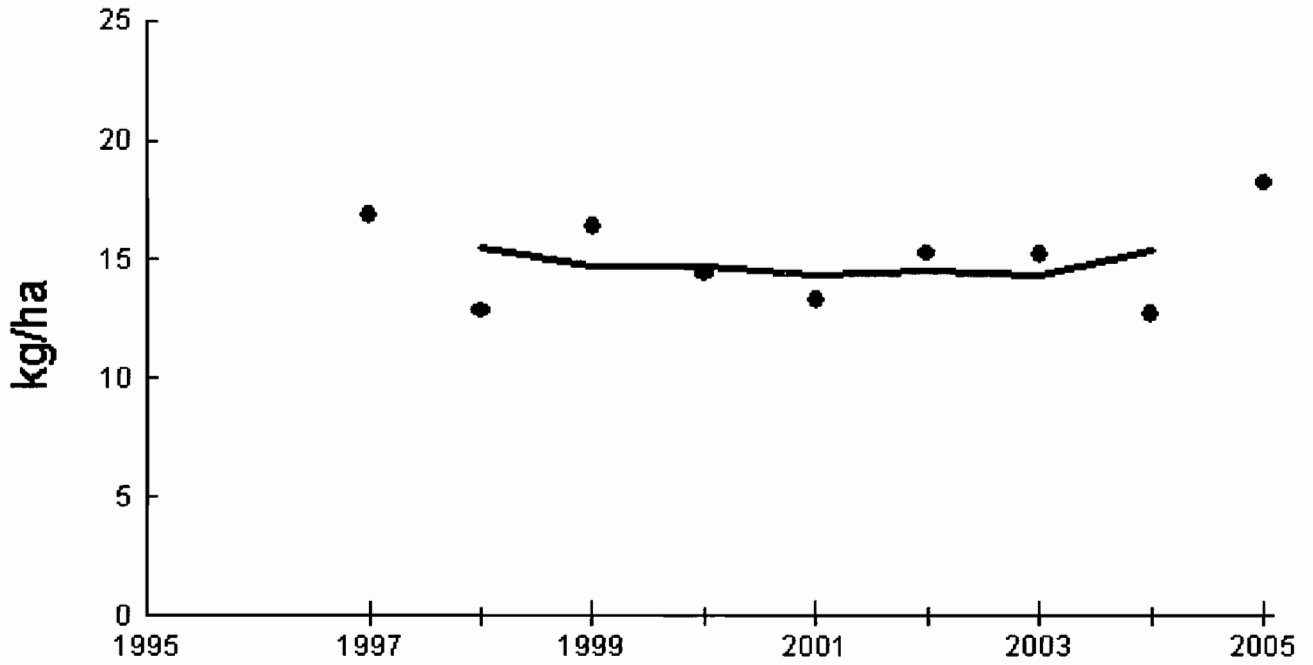

FIGURE 9-2.  
 NADP WET DEPOSITION VALUES AND 3-YEAR  
 WEIGHTED AVERAGE TRENDLINE FOR SO<sub>3</sub>  
 WITHIN THE CHASSAHOWITZKA NWA

Source: ECT, 2007.



### **9.2.5.2 Everglades NP**

Due to the relatively large distance from Unit 6 to the Everglades NP (211 km), Unit 6 air quality impacts on soils, vegetation, and wildlife will be insignificant at this Class I area. Unit 6 air quality impacts will be well below the PSD Class I SILs for NO<sub>2</sub>, SO<sub>2</sub>, and PM<sub>10</sub>. Maximum Unit 6 annual average NO<sub>2</sub>, SO<sub>2</sub>, and PM<sub>10</sub> impacts at the Everglades NP are only 0.9, 1.7, and 0.9 percent of the annual average PSD Class I SILs. Similarly, maximum Unit 6 24-hour average SO<sub>2</sub> and PM<sub>10</sub> impacts are only 22.7 and 17.9 percent of the 24-hour average PSD Class I SILs. Unit 6 air quality impacts at the Everglades NP are well below the levels previously shown in Tables 9-3 through 9-5 that would result in adverse effects on soils, vegetation, and wildlife.

### **9.3 VISIBILITY IMPAIRMENT POTENTIAL**

No visibility impairment at the local level is expected due to the types and quantities of emissions projected for Unit 6. Visible emissions from the CT/HRSG stacks, the primary Unit 6 emission source, will be 20 percent or less, excluding water. Emissions of primary particulates and sulfur oxides from Unit 6 will be low due to the use of low sulfur syngas and pipeline quality natural gas. Unit 6 will comply with all applicable FDEP requirements pertaining to visible emissions.

## 10.0 CLASS I IMPACT RESULTS

### 10.1 OVERVIEW

Comprehensive refined modeling was conducted to assess Unit 6 Class I area air quality impacts in accordance with EPA, Federal Land Managers (FLMs), and FDEP modeling guidance. This section provides the results of the Unit 6 air quality assessment with respect to long-range transport impacts at two PSD Class I areas: the Chassahowitzka NWA and Everglades NP. Unit 6 air quality impacts in the vicinity of the project site were previously addressed in Section 7.0.

PSD Class I areas located within 300 km of Unit 6 include the Chassahowitzka NWA and Everglades NP in Florida. The nearest PSD Class I area is the Chassahowitzka NWA situated approximately 117 km (73 miles) to the northwest of Unit 6; distances from the Unit 6 to receptors at this Class I area range from 117.3 to 135.2 km. Unit 6 is situated approximately 211 km (310 miles) northwest of the Everglades NP; distances from Unit 6 to receptors at this Class I area range from 211.3 to 337.6 km. The Class I impact analyses for Unit 6 addressed these two PSD Class I areas located within 300 km of the project site. Figure 10-1 provides the locations of these Class I areas in relation to Unit 6.

### 10.2 CONCLUSIONS

Comprehensive dispersion modeling using the CALMET/CALPUFF/CALPOST modeling suite demonstrates that the Unit 6 will have insignificant air quality impacts for all modeled PSD pollutants and all averaging periods. Accordingly, a multisource cumulative assessment of air quality impacts with respect to the PSD Class I increments for NO<sub>2</sub>, SO<sub>2</sub>, and PM<sub>10</sub> was not required.

Assessment of Unit 6 regional haze impacts were conducted using the following methodologies:

- Procedure 1—EPA Version 5.8 of the CALPUFF modeling suite, background extinction computation Method 2, and the current Interagency

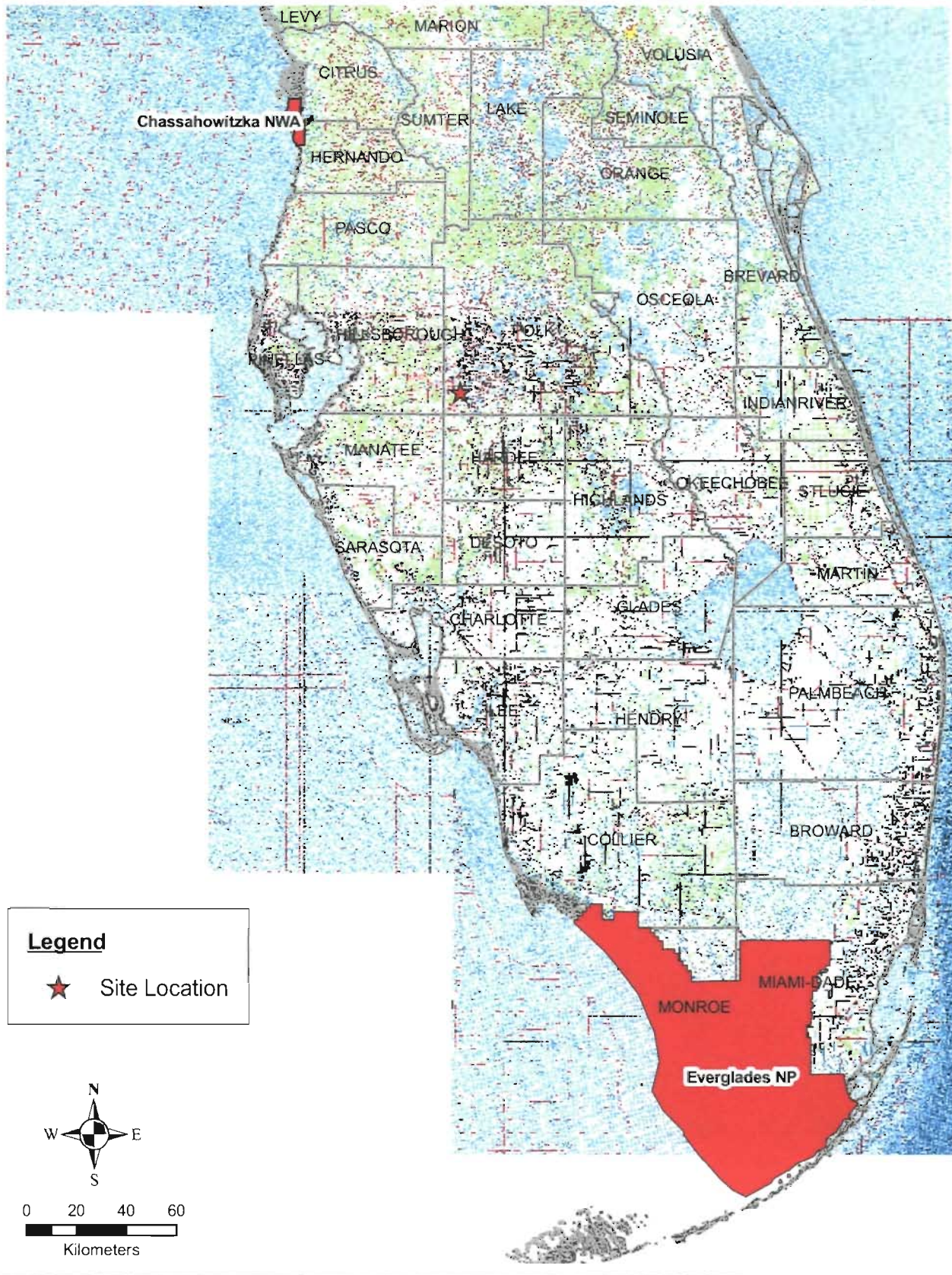

FIGURE 10-1.  
LOCATION OF CLASS 1 AREAS

Sources: FGDL, 2003; ECT, 2007.





Monitoring of Protected Visual Environments (IMPROVE) light extinction algorithm.

- Procedure 2—Procedure 1 procedures with the new IMPROVE light extinction algorithm.
- Procedure 3—Procedure 2 procedures with background extinction computation Method 6. This is the approach that was required for Class I regional haze impacts under the Clean Air Visibility Rule (CAVR) for best available retrofit technology (BART) eligible emission sources.

Based on the results of these analyses, it is concluded that Unit 6 will not adversely affect visibility at any Class I area. Section 10.7.3 provides further discussion of regional haze impacts.

The Unit 6 Class I area assessments of nitrogen and sulfur deposition demonstrate that that these impacts will not adversely affect the ecology of any Class I area.

### **10.3 GENERAL APPROACH**

The required Class I area impact assessments were conducted using the CALPUFF dispersion model in accordance with the recommendations contained in the Interagency Workgroup on Air Quality Modeling (IWAQM) *Phase 2 Summary Report and Recommendations for Modeling Long Range Transport Impacts*, the Federal Land Managers' Air Quality Related Values Workgroup (FLAG) Phase I Report, and EPA's Guideline on Air Quality Models (GAQM). In addition, an Air Quality Impact Analysis Modeling Protocol was submitted to FDEP, the National Park Service (NPS), the Fish and Wildlife Service (FWS) and EPA Region 4 in June 2007 for review and comments. The air quality impact analyses conducted for Unit 6 incorporates the comments and suggestions received from these regulatory agencies on the modeling protocol. As noted previously, the Unit 6 assessment of regional haze impacts employed several modeling approaches.

The CALPUFF model was employed in a refined mode using 3 years (2001 through 2003) of 4-km resolution CALMET data and Class I area receptor grids as recommended by the NPS. The CALPUFF suite of programs, including the POSTUTIL and CALPOST

postprocessing programs, was employed to develop estimates of Unit 6 impacts on each of the two Class I areas located within 300 km for PSD increments, regional haze, and deposition.

#### **10.4 MODEL SELECTION AND USE**

Steady-state dispersion models do not consider temporal or spatial variations in plume transport direction nor do they limit the downwind transport of a pollutant as a function of windspeed and travel time. Due to these limitations, conventional steady-state dispersion models, such as AERMOD, are not considered suitable for predicting air quality impacts at receptors located more than 50 km from an emission source.

Because of the need to assess air quality impacts at PSD Class I areas, which are typically located at distances greater than 50 km from the emission sources of interest, EPA and the FLMs initiated efforts to develop dispersion models appropriate for the assessment of long-range transport of air pollutants. The IWAQM was formed to coordinate the model development efforts of EPA and the FLMs.

The IWAQM work plan indicates that a phased approach would be taken with respect to the implementation of recommendations for long-range transport modeling. In Phase 1, the IWAQM would review current EPA modeling guidance and issue an interim modeling approach applicable to projects undergoing permit review. For Phase 2, a review would be made of other available long-range transport models and recommendations developed for the most appropriate modeling techniques.

The Phase 1 recommendation, issued in April 1993, is to use the Lagrangian puff model, MESOPUFF II, for long-range transport air quality assessments. The Phase 2 recommendations, issued in December 1998, are contained in the IWAQM *Phase 2 Summary Report and Recommendations for Modeling Long-Range Transport Impacts*. Additional FLM guidance with respect to the assessment of visibility and deposition impacts is provided in the FLAG Phase I report dated December 2000. The Phase 2 IWAQM recommendation is to apply the CALPUFF Modeling System to assess air quality impacts at distances greater than 50 km from an emission source. In April 2003, EPA designated the

CALPUFF model as a preferred model (i.e., a model listed in Appendix A to Appendix W of 40 CFR 51, Summaries of Preferred Air Quality Models) for use in assessing the long-range transport of air pollutants.

The EPA GAQM indicates that the CALPUFF modeling system is appropriate for long-range transport (source-receptor distances of 50 to several hundred kilometers) of emissions from point, volume, area, and line sources. All the receptors at the Class I areas evaluated are situated greater than 50 km from Unit 6.

The EPA-approved version of the CALPUFF modeling suite was used for the Unit 6 Class I area impact assessments. The EPA-approved CALPUFF modeling suite is comprised of the following programs:

- |            |                 |               |
|------------|-----------------|---------------|
| • CALMET   | Version 5.8     | Level: 070623 |
| • CALPUFF  | Version: 5.8    | Level: 070623 |
| • POSTUTIL | Version: 1.56   | Level: 070627 |
| • CALPOST  | Version: 5.6394 | Level: 070622 |

These programs were used to assess PSD Class I increments, regional haze, and nitrogen and sulfur deposition impacts.

The CALPUFF modeling system consists of three main components: CALMET, CALPUFF, and CALPOST. Each of these components is described in the following subsections.

#### **10.4.1 CALMET**

CALMET is a meteorological model that develops hourly wind and temperature fields on a three-dimensional gridded modeling domain. The meteorological file produced by CALMET for use by CALPUFF also includes two-dimensional parameters such as mixing height, surface characteristics, and dispersion properties.

CALMET requires a number of input data files to develop the gridded three- and two-dimensional meteorological file used by CALPUFF. The specific meteorological data used by the CALMET program include:

- Penn State/National Center for Atmospheric Research mesoscale model gridded, prognostic wind field data (terrain elevation, land use code, sea level pressure, rainfall amount, snow cover indicator, pressure, temperature/dew point, wind direction, and windspeed).
- Surface station weather data (windspeed, wind direction, ceiling height, opaque sky cover, air temperature, relative humidity, station pressure, and precipitation type code).
- Upper air sounding (mixing height) data (pressure, height above sea level, temperature, wind direction, and windspeed at each sounding).
- Surface station precipitation data (precipitation rates).
- Overwater data (air-sea surface temperature difference, air temperature, relative humidity, overwater mixing height, windspeed, and wind direction).
- Geophysical data (land use type, terrain elevation, surface parameters including surface roughness, length, albedo, Bowen ratio, soil heat flux, and vegetation leaf area index, and anthropogenic heat flux).

Further technical discussion of the CALMET model can be found in Section 2 of the User's Guide for the CALMET meteorological model dated January 2000.

VISTAS has developed a 3-year (2001 through 2003) CALMET dataset for a fine, 4-km, subregional domain that covers all of Florida and the adjacent Class I areas of interest to Florida. The VISTAS 2001-2003 meteorological data was recently re-processed by the FWS using the current EPA regulatory version of CALMET; i.e., Version 5.8, Level: 070623. This re-processed fine-grid CALMET dataset (containing more than 250 gigabytes of data) was obtained from FDEP and was used in the Unit 6 Class I impact assessments.

### 10.4.2 CALPUFF

CALPUFF is a transport and puff model that advects puffs of material from an emission source. These puffs undergo various dispersion and transformation simulation processes as they are advected from an emission source to a receptor of interest. The simulation processes include wet and dry deposition and chemical transformation. CALPUFF typically uses the gridded meteorological data created by the CALMET program. CALPUFF, when used in a screening mode, can also use nongridded meteorological data similar to that used by a steady-state dispersion model such as AERMOD. The distribution of puffs by CALPUFF explicitly incorporates the temporal and spatial variations in the meteorological fields thereby overcoming one of the main shortcomings of steady-state dispersion models. Further technical discussion of the CALPUFF model can be found in Section 2 of the User's Guide for the CALPUFF Model dated January 2000.

There are a number of optional CALPUFF input files that were not used for the Unit 6 Class I area impact assessments. These include time-varying emission rates, user-specified deposition velocities and chemical transformation conversion rates, complex terrain receptor and hill geometry data, and coastal boundary data.

CALPUFF generates output files consisting of hourly concentrations, deposition fluxes, and data required for visibility assessments for each receptor. These CALPUFF output files are subsequently processed by the POSTUTIL and CALPOST programs to provide impact summaries for the pollutants and averaging periods of interest.

The various CALPUFF program options are implemented by means of a control file. CALPUFF options selected for the Unit 6 Class I area impact assessments conform to the recommendations contained in the IWQAM Phase 2 report and EPA's GAQM. Key CALPUFF model options selected for the Unit 6 Class I impact assessments are listed:

- CALPUFF domain configured to include the Unit 6 emission sources and all Class I receptors with a minimum 50-km buffer in all directions.
- 4-km spacing meteorological and computational grid.
- Class I receptors as defined by the NPS.

- Modeling of 11 species (SO<sub>2</sub>, SO<sub>4</sub>, NO<sub>x</sub>, nitric acid, nitrate, PM<sub>1.0</sub>, PM<sub>0.25</sub>, PM<sub>0.20</sub>, PM<sub>0.15</sub>, PM<sub>0.10</sub>, and PM<sub>0.05</sub>).
- Use of the MESOPUFF II chemical mechanism module.
- IWAQM default guidance, including Pasquill-Gifford dispersion coefficients.
- 2001 through 2003 ozone data from CASTNet and AIRS stations.
- Background ammonia concentration of 0.5 part per billion (ppb).
- Integrated puff sampling methodology.
- No consideration of building downwash.

The PM fractions indicated herein address the PM size distribution expected for the Unit 6 CT/HRSG units. The Class I impacts for the PM<sub>10</sub> fractions, together with primary sulfate impacts, were summed to obtain total PM<sub>10</sub> impacts.

#### **10.4.3 POSTUTIL**

POSTUTIL is a postprocessing program used to process the concentrations generated by CALPUFF. POSTUTIL was used to recompute the nitric acid/nitrate concentration partition, develop visibility PM component emission rates (i.e., elemental and organic carbon PM fractions), consolidate the PM<sub>10</sub> impacts (i.e., impacts due to PM<sub>10</sub> fractions and primary sulfate), consolidate the wet and dry nitrogen and sulfur fluxes, and convert sulfate and nitrate fluxes to total sulfur and total nitrogen fluxes.

#### **10.4.4 CALPOST**

CALPOST is a postprocessing program used to process the concentration, deposition, and visibility files generated by CALPUFF. The CALPOST program was formulated to average and report pollutant concentrations or wet/dry deposition fluxes using the hourly data contained in the CALPUFF output files. CALPOST can produce summary tables of pollutant concentrations and depositions for each receptor for various averaging times and can develop ranked lists of these impacts. For visibility-related modeling (e.g., regional haze), CALPOST uses the CALPUFF generated pollutant concentrations to calculate extinction coefficients and other related indicators of visibility.

For visibility assessments, background conditions were estimated using natural background data (i.e., absent anthropogenic influences). The CALPOST program was then used to compute background extinction coefficients using the natural background data and the IWQAM recommended extinction efficiency for each species.

Similar to the CALPUFF program, the various CALPOST program options are implemented by means of a control file. CALPOST options selected for the Unit 6 Class I impact assessments conform to the recommendations contained in the FLAG Phase I report.

### **10.5 RECEPTOR GRIDS**

As noted previously, the Chassahowitzka NWA and Everglades NP in Florida are both located within 300 km from Unit 6. The receptor grids developed for Unit 6 addressed each of these Class I areas.

Accordingly, the Unit 6 Class I area receptor grids included the Chassahowitzka NWA (113 discrete receptors), and the Everglades NP (901 discrete receptors) receptors identified by the NPS for these two Class I areas. The Class I receptor locations, which are provided by the NPS in geographic (latitude and longitude) coordinates, were converted to Lambert Conformal Conic coordinates consistent with the VISTAS fine 4-km CALMET grid parameters (i.e., two matching parallels, latitude/longitude of the projection origin, and coordinate datum) using the NPS Class I Areas Conversion program.

All receptors were included in each CALPUFF model run. In CALPOST, only the receptor ranges for the specific Class I areas were processed.

### **10.6 MODELED EMISSION SOURCES**

Unit 6 modeled emission sources included the two CT/HRSG units and the sulfuric acid plant. The Unit 6 point and fugitive material handling and cooling tower emission sources will have minor PM<sub>10</sub> emission rates and low release heights. Accordingly, these emission sources will have negligible impacts at the distant Class I areas. The Unit 6 flare (in use during gasifier startups, shutdowns, and process upsets) and auxiliary boiler (in use

during gasifier startups) will not be in service during normal Unit 6 operations. The emergency diesel engines (which will operate approximately 2 hours per week for routine testing and maintenance, excluding emergencies) will have relatively minor emission rates and will operate infrequently. Accordingly, these Unit 6 emission sources will also have negligible impacts at the Class I areas.

The maximum emission rates were used for each modeled Unit 6 emission source. Table 10-1 summarizes the Unit 6 emission source stack parameters and emission rates used in the CALPUFF modeling assessments.

## **10.7 MODEL RESULTS**

Unit 6 CALPUFF modeling results for Class I PSD increments, deposition impacts, and regional haze (i.e., visibility) at the two Class I areas evaluated are discussed in the following subsections.

### **10.7.1 PSD CLASS I SIGNIFICANT IMPACT LEVEL ANALYSIS**

Table 10-2 summarizes Unit 6 NO<sub>2</sub>, SO<sub>2</sub>, and PM<sub>10</sub> impacts with respect to the PSD SILs. This table provides the highest annual average impacts (for NO<sub>2</sub>, SO<sub>2</sub>, and PM<sub>10</sub>), highest 3-hour average impacts (for SO<sub>2</sub>), and highest 24-hour average impacts (for SO<sub>2</sub> and PM<sub>10</sub>) for the two Class I areas evaluated.

All impacts are below the PSD Class I SILs for all pollutants and all averaging periods. Accordingly, a multisource cumulative assessment of air quality impacts with respect to the PSD Class I increments for NO<sub>2</sub>, SO<sub>2</sub>, and PM<sub>10</sub> was not required.

### **10.7.2 SULFUR AND NITROGEN DEPOSITION**

Table 10-3 summarizes the Unit 6 total wet and dry annual sulfur and nitrogen deposition rates for each Class I area evaluated. As shown, Unit 6 sulfur and nitrogen deposition impacts at each Class I area will be below the FLM sulfur and nitrogen deposition analysis threshold (DAT) of 0.01 kg/ha/yr.



Table 10-1. CALPUFF Modeling Data—Unit 6

Parameter	Units	Value
<u>CT/HRSG Units (per unit)</u>		
Stack height	ft	175
Stack diameter	ft	18.6
Stack velocity	ft/sec	80.4
Stack temperature	°F	275
SO <sub>2</sub> emissions	lb/hr	54.0
H <sub>2</sub> SO <sub>4</sub> emissions	lb/hr	12.8
NO <sub>x</sub> emissions	lb/hr	100.0
PM <sub>10</sub> emissions (excluding H <sub>2</sub> SO <sub>4</sub> mist)	lb/hr	26.2
<u>Sulfuric Acid Plant</u>		
Stack height	ft	275
Stack diameter	ft	6.5
Stack velocity	ft/sec	29.0
Stack temperature	°F	180
SO <sub>2</sub> emissions	lb/hr	36.7
H <sub>2</sub> SO <sub>4</sub> emissions	lb/hr	3.7

Source: ECT, 2007.

Table 10-2. Summary of Unit 6 PSD Class I Air Quality Impacts—NO<sub>x</sub>, SO<sub>2</sub>, and PM<sub>10</sub>

Pollutant	Year of Meteorology	Averaging Period	Class I Area Impact	
			Chassahowitzka NWA (µg/m <sup>3</sup> )	Everglades NP (µg/m <sup>3</sup> )
NO <sub>x</sub>	2001	Annual	0.0036	0.00054
	2002		0.0040	0.00088
	2003		0.0032	0.00059
	<b>Maximum</b>		<b>0.0040</b>	<b>0.00088</b>
	PSD SIL		0.1	0.1
% of PSD SIL		4.0	0.9	
Exceed PSD SIL		N	N	
SO <sub>2</sub>	2001	Annual	0.0043	0.0011
	2002		0.0047	0.0017
	2003		0.0043	0.0013
	<b>Maximum</b>		<b>0.0047</b>	<b>0.0017</b>
	PSD SIL		0.1	0.1
% of PSD SIL		4.7	1.7	
Exceed PSD SIL		N	N	
SO <sub>2</sub>	2001	24-Hour	0.075	0.037
	2002		0.054	0.045
	2003		0.082	0.042
	<b>Maximum</b>		<b>0.082</b>	<b>0.045</b>
	PSD SIL		0.2	0.2
% of PSD SIL		40.8	22.7	
Exceed PSD SIL		N	N	
SO <sub>2</sub>	2001	3-Hour	0.33	0.098
	2002		0.23	0.127
	2003		0.24	0.143
	<b>Maximum</b>		<b>0.33</b>	<b>0.143</b>
	PSD SIL		1.0	1.0
% of PSD SIL		33.0	14.3	
Exceed PSD SIL		N	N	
PM <sub>10</sub>	2001	Annual	0.0035	0.0011
	2002		0.0042	0.0017
	2003		0.0036	0.0015
	<b>Maximum</b>		<b>0.0042</b>	<b>0.0017</b>
	PSD SIL		0.2	0.2
% of PSD SIL		2.1	0.9	
Exceed PSD SIL		N	N	
PM <sub>10</sub>	2001	24-Hour	0.053	0.028
	2002		0.044	0.054
	2003		0.068	0.042
	<b>Maximum</b>		<b>0.068</b>	<b>0.054</b>
	PSD SIL		0.3	0.3
% of PSD SIL		22.6	17.9	
Exceed PSD SIL		N	N	

Source: ECT, 2007.

Table 10-3. Summary of Unit 6 PSD Class I Air Quality Impacts—Nitrogen and Sulfur Deposition

Pollutant	Year of Meteorology	Averaging Period	Chassahowitzka NWA		Everglades NP	
			( $\mu\text{g}/\text{m}^2/\text{s}$ )	(kg/ha/yr)	( $\mu\text{g}/\text{m}^2/\text{s}$ )	(kg/ha/yr)
Total Wet and Dry Nitrogen Deposition	2001	Annual	0.000013	0.0042	0.0000016	0.00050
	2002		0.000011	0.0035	0.0000029	0.00092
	2003		0.000012	0.0037	0.0000018	0.00056
	<b>Maximum</b>		<b>0.000013</b>	<b>0.0042</b>	<b>0.0000029</b>	<b>0.00092</b>
FLM DAT			0.01		0.01	
% of FLM DAT SIL				41.5		9.2
Exceed FLM DAT				N		N
Total Wet and Dry Sulfur Deposition	2001	Annual	0.000024	0.0077	0.0000036	0.0011
	2002		0.000022	0.0070	0.0000056	0.0018
	2003		0.000021	0.0067	0.0000043	0.0014
	<b>Maximum</b>		<b>0.000024</b>	<b>0.0077</b>	<b>0.0000056</b>	<b>0.0018</b>
FLM DAT			0.01		0.01	
% of FLM DAT SIL				77.2		17.8
Exceed FLM DAT				N		N

Source: ECT, 2007.

### 10.7.3 REGIONAL HAZE

Assessment of Unit 6 regional haze impacts was conducted for the Chassahowitzka NWA and Everglades NP in Florida. The regional haze assessments employed three analytical procedures and the EPA-approved version of the CALPUFF modeling suite. The analytical procedures included:

- Procedure 1—FLAG, NPS, and IWAQM recommended procedures including use of background extinction computation Method 2 (compute extinction from speciated PM measurements and hourly relative humidity adjustment applied to observed and modeled sulfate and nitrate), and the current IMPROVE light extinction algorithm.
- Procedure 2—Procedure 1 procedures with the new IMPROVE light extinction algorithm.
- Procedure 3—Procedure 2 procedures using background extinction computation Method 6 (compute extinction from speciated PM measurements and FLAG monthly RH adjustment factor applied to observed and modeled sulfate and nitrate).

The new IMPROVE light extinction algorithm provides a better correspondence between the measured visibility and that calculated from PM component concentrations. Technical improvements contained in the new IMPROVE algorithm include:

- Extinction efficiencies of sulfates, nitrates, and organics have been changed and are functions of their concentrations. The extinction efficiencies of sulfate and nitrate are no longer identical, although the new hygroscopic scattering enhancement factors applied to them are the same.
- The concentration of particulate organic matter is taken to be 1.8 times that of the measured organic carbon concentration.
- The contribution of fine sea salt to light extinction has been added, and is accompanied by its own hygroscopic scattering enhancement factor,  $f_{ss}(RH)$ .

- The light scattering by air itself (Rayleigh scattering) now varies with site elevation.
- The light absorption by NO<sub>2</sub> gas has been added.

The analytical procedures described for assessing regional haze compare project visibility impacts to natural background levels that would occur in the absence of all anthropogenic activities. In addition, the methods do not consider the effects of natural visibility impairment caused by rain or fog events. During such natural visibility impairment events, much lower visibility will occur compared to the assumed natural background level.

The results of the Unit 6 regional haze assessments for each Class I area evaluated are provided in the following subsections. Results are provided for the highest 24-hour average impact as well as the 98<sup>th</sup> percentile of the 24-hour average impacts (equivalent to the eighth highest 24-hour average impact at any receptor). The 24-hour average 98<sup>th</sup> percentile impact is the metric used for the assessment of regional haze impacts under the BART provisions of the CAVR. As stated in the preamble to the final BART rules issued on July 5, 2005, EPA agreed that the maximum 24-hour visibility impacts could be the result of unusual meteorological conditions. For this reason, the 98<sup>th</sup> percentile value was selected to eliminate unusual and infrequent weather conditions from unduly influencing visibility analyses. As further justification for selecting the 98<sup>th</sup> percentile value, EPA also stated that the simplified chemistry in the CALPUFF model tends to magnify the actual visibility effects of a source. Accordingly, use of the 98<sup>th</sup> percentile (eighth highest 24-hour average impact for any receptor), rather than the highest 24-hour average impact, is considered to be the most appropriate approach for assessing visibility impacts at Class I areas.

#### **10.7.3.1 Chassahowitzka NWA**

Tables 10-4 through 10-6 provide Unit 6 visibility impacts at the Chassahowitzka NWA for Procedure 1 (FLAG procedures, Method 2, and old IMPROVE algorithm), Procedure 2 (FLAG procedures, Method 2, and new IMPROVE algorithm), and Procedure 3 (FLAG procedures, Method 6, and new IMPROVE algorithm), respectively. An overall summary

Table 10-4. Unit 6 Chassahowitzka NWA Regional Haze Impacts—Procedure 1\*

Maximum 24-Hour Average Impacts	Units	2001	2002	2003	Maximum
$B_{\text{ext-s}} - \text{SO}_4$	$\text{Mm}^{-1}$	0.682	0.735	0.591	0.735
$B_{\text{ext-s}} - \text{NO}_3$	$\text{Mm}^{-1}$	0.568	0.106	0.354	0.568
$B_{\text{ext-s}} - \text{Organic Carbon (OC)}$	$\text{Mm}^{-1}$	0.065	0.035	0.074	0.074
$B_{\text{ext-s}} - \text{Elemental Carbon (EC)}$	$\text{Mm}^{-1}$	0.164	0.088	0.186	0.186
$B_{\text{ext-s}} - \text{Total}$	$\text{Mm}^{-1}$	1.479	0.964	1.205	1.479
$B_{\text{ext-b}} - \text{Background}$	$\text{Mm}^{-1}$	23.9	24.0	23.2	24.0
Visual Range, Background	km	163.5	163.2	168.7	168.7
Visual Range, Background	mi	101.6	101.4	104.8	104.8
Visual Range, Background	dv	8.7	8.7	8.4	8.7
Relative Humidity Factor - f(RH)	-	6.02	6.08	5.21	6.08
No. of Days with $B_{\text{ext}} > 5.0\%$	-	1	0	1	1
No. of Days with $B_{\text{ext}} > 10.0\%$	-	0	0	0	0
Largest $B_{\text{ext}}$ change	%	6.18	4.02	5.20	6.18
NPS Significant Impact, Bext change	%	5.00	5.00	5.00	5.00
Exceed NPS Significant Impact	Y/N	Y	N	Y	Y
Percent of NPS Significant Impact	%	123.6	80.4	104.0	123.6
No. of Days with Delta Deciview $> 0.5\%$	-	1	0	1	1
No. of Days with Delta Deciview $> 1.0\%$	-	0	0	0	0
Largest Delta Deciview Change	-	0.600	0.394	0.507	0.600
Receptor LCC Easting (km)	km	1,408.3	1,410.8	1,406.3	
Receptor LCC Northing (km)	km	-1,154.0	-1,153.7	-1,141.1	
Distance From Unit 6 (km)	km	120.3	118.9	131.4	
Direction From Unit 6 (Vector °)	Vector °	317	318	320	

\*Background light extinction Method 2, old IMPROVE algorithm.

Source: ECT, 2007.

Table 10-5. Unit 6 Chassahowitzka NWA Regional Haze Impacts—Procedure 2\*

Maximum 24-Hour Average Impacts	Units	2001	2002	2003
$B_{\text{ext-s}}$ - SO <sub>4</sub>	Mm <sup>-1</sup>	0.560	0.598	0.497
$B_{\text{ext-s}}$ - NO <sub>3</sub>	Mm <sup>-1</sup>	0.508	0.094	0.323
$B_{\text{ext-s}}$ - Organic Carbon (OC)	Mm <sup>-1</sup>	0.050	0.027	0.057
$B_{\text{ext-s}}$ - Elemental Carbon (EC)	Mm <sup>-1</sup>	0.164	0.088	0.186
$B_{\text{ext-s}}$ - Total	Mm <sup>-1</sup>	1.282	0.807	1.064
$B_{\text{ext-b}}$ - Background	Mm <sup>-1</sup>	24.9	24.0	24.3
Visual Range, Background	km	156.9	163.2	161.0
Visual Range, Background	mi	97.5	101.4	100.0
Visual Range, Background	dv	9.1	8.7	8.9
Relative Humidity	%	93	93	92
No. of Days with $B_{\text{ext}}$ >5.0 %	-	1	0	0
No. of Days with $B_{\text{ext}}$ >10.0 %	-	0	0	0
Largest $B_{\text{ext}}$ change	%	5.25	3.31	4.50
NPS Significant Impact, $B_{\text{ext}}$ change	%	5.00	5.00	5.00
Exceed NPS Significant Impact	Y/N	Y	N	N
Percent of NPS Significant Impact	%	105.0	66.2	90.0
No. of Days with Delta Deciview >0.5 %	-	1	0	0
No. of Days with Delta Deciview >1.0 %	-	0	0	0
Largest Delta Deciview Change	-	0.511	0.326	0.440
Receptor LCC Easting (km)	km	1,408.3	1,410.8	1,406.3
Receptor LCC Northing (km)	km	-1,154.0	-1,153.7	-1,141.1
Distance From Unit 6 (km)	km	120.3	118.9	131.4
Direction From Unit 6 (Vector <sup>o</sup> )	Vector <sup>o</sup>	317	318	320

\*Background light extinction Method 2, new IMPROVE algorithm.

Source: ECT, 2007.

Table 10-6. Unit 6 Chassahowitzka NWA Regional Haze Impacts—Procedure 3\*

Maximum 24-Hour Average Impacts	Units	2001	2002	2003
B <sub>ext-s</sub> - SO <sub>4</sub>	Mm <sup>-1</sup>	0.245	0.335	0.385
B <sub>ext-s</sub> - NO <sub>3</sub>	Mm <sup>-1</sup>	0.187	0.044	0.122
B <sub>ext-s</sub> - Organic Carbon (OC)	Mm <sup>-1</sup>	0.050	0.027	0.058
B <sub>ext-s</sub> - Elemental Carbon (EC)	Mm <sup>-1</sup>	0.163	0.088	0.188
B <sub>ext-s</sub> - Total	Mm <sup>-1</sup>	0.646	0.494	0.753
B <sub>ext-b</sub> - Background	Mm <sup>-1</sup>	22.7	22.9	22.9
Visual Range, Background	km	172.5	171.0	171.0
Visual Range, Background	mi	107.2	106.3	106.3
Visual Range, Background	dv	8.2	8.3	8.3
Relative Humidity	%	87	88	88
No. of Days with B <sub>ext</sub> >5.0 %	-	0	0	0
No. of Days with B <sub>ext</sub> >10.0 %	-	0	0	0
Largest B <sub>ext</sub> change	%	2.96	2.24	3.42
NPS Significant Impact, Bext change	%	5.00	5.00	5.00
Exceed NPS Significant Impact	Y/N	N	N	N
Percent of NPS Significant Impact	%	59.2	44.8	68.4
No. of Days with Delta Deciview >0.5 %	-	0	0	0
No. of Days with Delta Deciview >1.0 %	-	0	0	0
Largest Delta Deciview Change	-	0.290	0.221	0.337
Receptor LCC Easting (km)	km	1,407.4	1,410.8	1,404.2
Receptor LCC Northing (km)	km	-1,153.3	-1,153.7	-1,138.6
Distance From Unit 6 (km)	km	121.5	118.9	134.6
Direction From Unit 6 (Vector <sup>o</sup> )	Vector <sup>o</sup>	317	318	320

\*Background light extinction Method 6, new IMPROVE algorithm.

Source: ECT, 2007.



of the Unit 6 visibility impacts at the Chassahowitzka NWA is provided in Table 10-7. Table 10-7 shows the highest 24-hour average and 98<sup>th</sup> percentile changes in  $B_{ext}$  and the number of days with a change in  $B_{ext}$  greater than 5 percent. Over the 3-year period of meteorological data, there were only 2 days that are projected to exceed a 5-percent change in  $B_{ext}$  (with a maximum 24-hour average value of 6.18 percent) or 0.18 percent of the time using the FLAG procedures and old IMPROVE algorithm. Use of background extinction computation Method 6 and the new IMPROVE algorithm resulted in a maximum value of 1.75 percent for the 24-hour average 98<sup>th</sup> percentile of the impacts.

### **10.7.3.2 Everglades NP**

Tables 10-8 through 10-10 provide Unit 6 visibility impacts at the Everglades NP for Procedure 1, 2, and 3, respectively. An overall summary of the Unit 6 visibility impacts at the Everglades NWA is provided in Table 10-11. Visibility impacts are all less than a 5-percent change in  $B_{ext}$  using the FLAG recommended procedures and old IMPROVE algorithm.

### **10.7.3.3 Conclusions**

Unit 6 regional haze impacts are considered acceptable for the following reasons:

- The frequency of occurrence of Unit 6 visibility impacts exceeding a 5-percent change in  $B_{ext}$  is low. For the 3-year period of meteorological data evaluated, maximum 24-hour average Unit 6 visibility impacts at the Chassahowitzka NWA were projected to exceed a 5-percent change in  $B_{ext}$  for only 2 days or 0.18 percent of the time using the FLAG procedures and old IMPROVE algorithm. All 24-hour average 98<sup>th</sup> percentile impacts were less than a 5-percent change in  $B_{ext}$ . Use of background extinction computation Method 6 and the new IMPROVE algorithm resulted in a maximum value of 1.75 percent for the 24-hour average 98<sup>th</sup> percentile Chassahowitzka NWA impacts. Unit 6 visibility impacts at the Everglades NP were all below a 5-percent change in  $B_{ext}$  using the FLAG procedures and old IMPROVE algorithm.

Table 10-7. Summary of Unit 6 Chassahowitzka NWA Regional Haze Impacts

Metric	Units	Year	Procedure		
			1	2	3
Maximum $\Delta B_{\text{ext}}$	%	2001	6.2	5.3	3.0
		2002	4.0	3.3	2.2
		2003	5.2	4.5	3.8
98 <sup>th</sup> Percentile $\Delta B_{\text{ext}}$ (8th Highest Day - All Receptors)	%	2001	2.6	2.3	1.8
		2002	2.5	2.3	1.7
		2003	2.1	1.8	1.6
Days With $\Delta B_{\text{ext}} > 10\%$	-	2001	0	0	0
		2002	0	0	0
		2003	0	0	0
Days With $\Delta B_{\text{ext}} > 5\%$	-	2001	1	1	0
		2002	0	0	0
		2003	1	0	0

Procedure 1—Background light extinction Method 2, Rayleigh = 10.0, Old IMPROVE algorithm

Procedure 2—Background light extinction Method 2, Rayleigh = 10.0, New IMPROVE algorithm

Procedure 3—Background light extinction Method 6, Rayleigh = 11.0, New IMPROVE algorithm

Source: ECT, 2007.

Table 10-8. Unit 6 Everglades NP Regional Haze Impacts—Procedure 1\*

Maximum 24-Hour Average Impacts	Units	2001	2002	2003
B <sub>ext-s</sub> - SO <sub>4</sub>	Mm <sup>-1</sup>	0.348	0.344	0.294
B <sub>ext-s</sub> - NO <sub>3</sub>	Mm <sup>-1</sup>	0.267	0.278	0.160
B <sub>ext-s</sub> - Organic Carbon (OC)	Mm <sup>-1</sup>	0.022	0.028	0.030
B <sub>ext-s</sub> - Elemental Carbon (EC)	Mm <sup>-1</sup>	0.054	0.070	0.074
B <sub>ext-s</sub> - Total	Mm <sup>-1</sup>	0.691	0.720	0.558
B <sub>ext-b</sub> - Background	Mm <sup>-1</sup>	23.1	23.1	23.5
Visual Range, Background	km	169.1	169.1	166.7
Visual Range, Background	mi	105.1	105.1	103.6
Visual Range, Background	dv	8.4	8.4	8.5
Relative Humidity Factor - f(RH)	-	5.15	5.15	5.51
No. of Days with B <sub>ext</sub> >5.0 %	-	0	0	0
No. of Days with B <sub>ext</sub> >10.0 %	-	0	0	0
Largest B <sub>ext</sub> change	%	2.98	3.12	2.38
NPS Significant Impact, Bext change	%	5.00	5.00	5.00
Exceed NPS Significant Impact	Y/N	N	N	N
Percent of NPS Significant Impact	%	59.6	62.4	47.6
No. of Days with Delta Deciview >0.5 %	-	0	0	0
No. of Days with Delta Deciview >1.0 %	-	0	0	0
Largest Delta Deciview Change	-	0.294	0.307	0.235
Receptor LCC Easting (km)	km	1,642.0	1,581.8	1,647.1
Receptor LCC Northing (km)	km	-1,441.7	-1,437.9	-1,440.8
Distance From Unit 6 (km)	km	250.8	216.2	253.1
Direction From Unit 6 (Vector °)	Vector °	143	155	142

\*Background light extinction Method 2, old IMPROVE algorithm.

Source: ECT, 2007.

Table 10-9. Unit 6 Everglades NP Regional Haze Impacts—Procedure 2\*

Maximum 24-Hour Average Impacts	Units	2001	2002	2003
$B_{\text{ext-s}}$ - SO <sub>4</sub>	Mm <sup>-1</sup>	0.296	0.292	0.264
$B_{\text{ext-s}}$ - NO <sub>3</sub>	Mm <sup>-1</sup>	0.247	0.257	0.156
$B_{\text{ext-s}}$ - Organic Carbon (OC)	Mm <sup>-1</sup>	0.017	0.022	0.023
$B_{\text{ext-s}}$ - Elemental Carbon (EC)	Mm <sup>-1</sup>	0.054	0.070	0.074
$B_{\text{ext-s}}$ - Total	Mm <sup>-1</sup>	0.614	0.641	0.517
$B_{\text{ext-b}}$ - Background	Mm <sup>-1</sup>	24.3	24.3	24.9
Visual Range, Background	km	161.0	161.0	156.9
Visual Range, Background	mi	100.0	100.0	97.5
Visual Range, Background	dv	8.9	8.9	9.1
Relative Humidity	%	92	92	93
No. of Days with $B_{\text{ext}} > 5.0$ %	-	0	0	0
No. of Days with $B_{\text{ext}} > 10.0$ %	-	0	0	0
Largest $B_{\text{ext}}$ change	%	2.54	2.68	2.10
NPS Significant Impact, Bext change	%	5.00	5.00	5.00
Exceed NPS Significant Impact	Y/N	N	N	N
Percent of NPS Significant Impact	%	50.8	53.5	42.1
No. of Days with Delta Deciview >0.5 %	-	0	0	0
No. of Days with Delta Deciview >1.0 %	-	0	0	0
Largest Delta Deciview Change	-	0.253	0.264	0.208
Receptor LCC Easting (km)	km	1,642.0	1,581.8	1,647.1
Receptor LCC Northing (km)	km	-1,441.7	-1,437.9	-1,440.8
Distance From Unit 6 (km)	km	250.8	216.2	253.1
Direction From Unit 6 (Vector <sup>o</sup> )	Vector <sup>o</sup>	143	155	142

\*Background light extinction Method 2, new IMPROVE algorithm.

Source: ECT, 2007.

Table 10-10. Unit 6 Everglades NP Regional Haze Impacts—Procedure 3\*

Maximum 24-Hour Average Impacts	Units	2001	2002	2003
B <sub>ext-s</sub> - SO <sub>4</sub>	Mm <sup>-1</sup>	0.093	0.206	0.166
B <sub>ext-s</sub> - NO <sub>3</sub>	Mm <sup>-1</sup>	0.060	0.010	0.034
B <sub>ext-s</sub> - Organic Carbon (OC)	Mm <sup>-1</sup>	0.021	0.040	0.034
B <sub>ext-s</sub> - Elemental Carbon (EC)	Mm <sup>-1</sup>	0.067	0.129	0.111
B <sub>ext-s</sub> - Total	Mm <sup>-1</sup>	0.240	0.385	0.345
B <sub>ext-b</sub> - Background	Mm <sup>-1</sup>	21.6	21.3	21.6
Visual Range, Background	km	180.9	183.5	180.9
Visual Range, Background	mi	112.4	114.0	112.4
Visual Range, Background	dv	7.7	7.6	7.7
Relative Humidity	%	87	88	88
No. of Days with B <sub>ext</sub> >5.0 %	-	0	0	0
No. of Days with B <sub>ext</sub> >10.0 %	-	0	0	0
Largest B <sub>ext</sub> change	%	1.15	1.86	1.63
NPS Significant Impact, Bext change	%	5.00	5.00	5.00
Exceed NPS Significant Impact	Y/N	N	N	N
Percent of NPS Significant Impact	%	23.0	37.1	32.7
No. of Days with Delta Deciview >0.5 %	-	0	0	0
No. of Days with Delta Deciview >1.0 %	-	0	0	0
Largest Delta Deciview Change	-	0.115	0.184	0.162
Receptor LCC Easting (km)	km	1,580.7	1,581.8	1,575.2
Receptor LCC Northing (km)	km	-1,446.8	-1,437.9	-1,444.8
Distance From Unit 6 (km)	km	223.8	216.2	219.8
Direction From Unit 6 (Vector °)	Vector °	156	155	157

\*Background light extinction Method 6, new IMPROVE algorithm.

Source: ECT, 2007.

Table 10-11. Summary of Unit 6 Everglades NP Regional Haze Impacts

Metric	Units	Year	Procedure		
			1	2	3
Maximum $\Delta B_{ext}$	%	2001	3.0	2.5	1.2
		2002	3.1	2.7	1.9
		2003	2.4	2.1	1.6
98 <sup>th</sup> Percentile $\Delta B_{ext}$ (8th Highest Day - All Receptors)	%	2001	1.2	1.0	0.6
		2002	1.6	1.4	0.8
		2003	1.4	1.2	0.8
Days With $\Delta B_{ext} > 10\%$	-	2001	0	0	0
		2002	0	0	0
		2003	0	0	0
Days With $\Delta B_{ext} > 5\%$	-	2001	0	0	0
		2002	0	0	0
		2003	0	0	0

Procedure 1—Background light extinction Method 2, Rayleigh = 10.0, Old IMPROVE algorithm.  
 Procedure 2—Background light extinction Method 2, Rayleigh = 10.0, New IMPROVE algorithm.  
 Procedure 3—Background light extinction Method 6, Rayleigh = 11.0, New IMPROVE algorithm.

Source: ECT, 2007.

- The 5-percent FLM guideline is half of the level that is perceptible (i.e., increases in  $B_{\text{ext}}$  above 10 percent are considered to be perceptible at the furthest extent of the visual range).
- The regional haze analysis compares project impacts with natural background (i.e., a theoretical background that would occur in the absence of all anthropogenic activities). This results in a natural background  $B_{\text{ext}}$  of approximately 24 inverse megameters and a visual range of 105 miles for the Chassahowitzka NWA. Other than nighttime celestial objects, there are no line-of-sight vistas in the coastal Chassahowitzka NWA that are near this visual range. For example, the theoretical line-of-sight for a 6-ft-tall person on the shoreline of the Gulf of Mexico is 3.2 miles due to the curvature of the earth.
- There will be significant actual reductions in actual Florida power plant  $\text{NO}_x$  and  $\text{SO}_2$  emissions due to implementation of CAIR. Statewide, CAIR is expected to reduce actual 2003 Florida power plant  $\text{SO}_2$  emissions by 54 percent in Phase 1 (a reduction in actual  $\text{SO}_2$  emissions of 257,000 tpy) and actual  $\text{NO}_x$  emissions by 73 percent (a reduction in actual  $\text{NO}_x$  emissions of 184,000 tpy). The Phase 1 CAIR actual emission reductions will occur prior to the commencement of Unit 6 operation. Improvement in regional haze would be expected to occur throughout Florida due to these substantial reductions in actual power plant emissions.

## REFERENCES

- Barbo DN, Chappelka AH, Stolte K. 1994. Ozone effects on productivity and diversity of an early successional forest community. Proceedings of the Eighth Biennial Southern Silvicultural Research Council. Auburn, Alabama. Nov 1-3, 291-298.
- Barett TW, Benedict HM. 1970. Sulfur dioxide. In: Recognition of air pollution injury to vegetation: A pictorial atlas. J.S. Jacobson and A.C. Hill, editors
- Bateman DR, Jarvis G, Carmody. 1994. Mercury concentrations in fishes of the St. Marks National Wildlife Refuge. Publication No. PCFO-EC-94-07. U.S. Fish and Wildlife Service, Panama City Field Office, Panama City, Florida.
- Bennett, JH, Hill, AC. 1975. Interactions of air pollutants with canopies of vegetation. In: Responses of plants to air pollution. J.B. Mudd and T.T. Kozlowski, editors.
- Bevanger K, Albu O. 1986. Decrease in a Norwegian feral mink (*Mustela vison*) population – a response to acid precipitation? *Biological Conservation* 38: 75-58.
- Bindler R. 2003. Estimating the natural background atmospheric deposition rate of mercury utilizing ombrotrophic bogs in southern Sweden. *Environmental science and technology* 37: 40-46.
- Blancher PJ, McAuley DG. 1987. Influence of wetland acidity on avian breeding success. *Transactions of the North American Wildlife and Natural Resources Conference* 52: 628-635.
- Byrd H J, Aydelott DG, Bacon DD, Stone EM. 1961. Soil survey of McIntosh County, Georgia. U.S. Dep. Agric. Soil Conserv. Serv. 98 p.
- Davis DD, Skelly JM. 1992. Growth response of four species of eastern hardwood tree seedlings exposed to ozone, acidic precipitation, and sulfur dioxide. *Journal of the Air & Waste Management Association* 42: 309-311
- Driscoll CT, Holsapple J, Schofield CL, Munson R. 1998. The chemistry and transport of mercury in a small wetland in the Adirondack region of New York, USA. *Biogeochemistry* 40: 137-146.
- Fitzgerald et al., 1996
- Florida Fish and Wildlife Conservation Commission. 2001. A conceptual management plan for Chassahowitzka National Wildlife Area 2002-2007. Tallahassee, Florida. Southeast Regional Office. Atlanta, Georgia.



- Goldstein, RA et al., 1985. Plant response to SO<sub>2</sub>: An ecosystem perspective. In: Sulfur dioxide and vegetation, pp. 403-417. Winner W.E., Mooney HA, Goldstein RA. (eds). Sanford University Press, Sanford, CA.
- Gough LP, Shacklette HT, Case AA. 1979. Element concentrations toxic to plants, animals, and man. U. S. Geological Survey Bulletin, Report: B 1466, 80 pp.
- Hart R, Webb PG, Biggs RH, Portier KM. 1988. The use of lichen fumigation studies to evaluate the effects of new emission sources on Class I areas. *Journal of air poll. Assoc.* 38: 144-147.
- Hindawi IJ. 1970. Air pollution injury to vegetation. Raleigh, N. C: U. S. National Air Pollution Control Administration; U.S.Govt.Print.Off., Washington, 1970. 44 pp.
- Hogsett WE, Plotcher M, Wildman V, Tingey DT, Bennett JP. 1985. Growth response of two varieties of slash pine seedlings to chronic ozone exposures. *Canadian journal of botany* 63: 2369-23.
- Johnson DW, Reuss JO. 1984. Soil-mediated effects of atmospherically deposited sulphur and nitrogen. *Phil. Trans. R. Soc. Lond.* 305: 383-392.
- Jones HC, Weber D, Balsillie D. 1974. Acceptable limits for air pollution dosages and vegetation effects: Sulfur dioxide. *Proceedings of the 67<sup>th</sup> Annual Meeting of the Air Pollution Control Association.*
- Jordan DN, Green TH, Chappelka AH, Lockaby BG, Meldahl RS, Gjerstad DH. 1991. Response of total tannins and phenolics in loblolly pine foliage exposed to ozone and acid rain. *Journal of chemical ecology* 17: 505-513.
- Krabbenhoft DP, Benoit JM, Babiarz CL, Hurley JP, Andren AW. 1995. Mercury cycling in the Allequash Creek watershed, northern Wisconsin. *Water, Air & Soil Pollution* 80: 425-433.
- Llacuna S., Gorriz A., Dufort M., Nadai I. 1993. Effects of air pollution on passerine birds and small mammals. *Arch. Environ. Contam. Toxicol.* 24: 59-66.
- Lawrence GB, Huntington TG. 1999. Soil-calcium depletion linked to acid rain and forest growth in the eastern united states. USGS Water-Resources Investigations Report 98-4267.
- LeBlanc F, Rao DN, Comeau G. 1972. The epiphytic vegetation of *Populus balsamitera* and its significance as an air pollution indicator in Sudbury, Ontario. *Can. J. Bot.* 50: 519-528.
- LeBlanc F, Rao DN. 1975. Effects of air pollutants on lichens and bryophytes. In: Responses of plants to air pollution. Mudd JB, and Kozlowski TT (eds).

- Longcore JR, Ross RK, Fischer KI. 1987. Wildlife resources at risk through acidification of wetlands. *Transactions of the North American Wildlife and Natural Resources Conference* 52: 608-618.
- MacLean DC, Delbert DC, BcCune DC, Weinstein LH, Mandl RH, Woodruff GN. 1968. Effects of acute hydrogen fluoride and nitrogen dioxide on citrus and ornamental plants of central Florida. *Enviorn. Sci. and Tech.* 2: 444-449.
- Majernik O, Mansfield TA. 1970. Direct effect of SO<sub>2</sub> pollution on the degree of opening of stomata. *Nature* 227: 377-378.
- Masson GR, Bowers MD. 1995. Mercury and lead levels in fish of the Okefenokee National Wildlife Refuge. Report by U.S. Fish and Wildlife Service, Environmental Contaminants Division, Brunswick, Georgia. 11 pp.
- Middleton JT, Kendrick JB, Schwalm HW. 1950. Smog in the south coastal area of California. *California agriculture* 4: 7-11.
- Mortensen L. 1993. Effects of ozone on growth of several subalpine plant species. *Norwegian journal of agricultural science* 7: 91-97.
- Mortensen L. 1994. Further studies on the effects of ozone concentration on growth of subalpine plant species. *Norwegian journal of agricultural science* 8: 91-97.
- Mortensen L, Nilsen J. 1992. Effects of ozone and temperature on growth of several wild plant species. *Norwegian journal of agricultural science* 6: 195-204.
- Mudd JB, Kozlowski TT. 1975. Peroxyaci Nitrates. In: Responses of plants to air pollution. JB Mudd and TT Kozlowski (eds).
- Newman JR. 1980. Effects of air emissions on wildlife resources. US Fish and Wildlife Service, Biological Services Program, National Power Plant Team, FWS/OBS-80/40.1 32 pp.
- Newman JR, Schreiber RK. 1985. Effects of acidic deposition and other energy emissions on wildlife: A compendium. *Veterinary and human toxicology* 27: 394-401.
- Newman, J.R. and R.K. Schreiber. 1988. Air Pollution and Wildlife Toxicology. *Environmental Toxicology and Chemistry.* 7: 381-390.
- Nikonov VV, Koptsik GN (eds.). 1999. Acid Deposition and Forest Soils. Apatity. 325 p. (In Russian).
- Porter, E. 2003. Ozone Sensitive Plant Species on National Park Service and U.S. Fish and Wildlife Service Lands: Results of a June 24-25, 2003 Workshop Baltimore, Maryland. Natural Resource Report NPS/NRARD/NRR-2003/01.

- Potter L, Foot JP, Caporn SJM, Lee A. 1996. The effects of long-term elevated ozone concentrations on the growth and photosynthesis of *Sphagnum recurvum* and *Polytrichum commune*. *New Phytologist* 134: 649-656.
- Prinz B, Brandt CJ. 1985. Effects of air pollution on vegetation. In: Pollutants and their ecotoxicological significance, pp. 67-84. H.W. Nurnberg, editor. John Wiley & Sons, New York.
- Pye JM. 1988. Impact of ozone on the growth and yield of trees: A review. *Journal of environmental quality* 17: 347-360.
- Rattner BA, Haramis GM, Chu DS, Bunck CM. 1987. Growth and physiological condition of black ducks reared in acidified wetlands. *Canadian Journal of Zoology* 65: 2953-2958.
- Reich, PE. 1987. Quantifying the response of plants to ozone: A unified explanation. *Tree phys.* 3: 63-91.
- Reiling K, Davison AW. 1992. Effects of a short ozone exposure given at different stages in the development of *Plantago major*. *New Phytologist* 120: 643-647.
- Reinert et al. 1975. Plant responses to pollutant combinations. In: Plant responses to air pollution. JB Mudd and TT Kozlowski (eds).
- Shanklin J, Kozlowski, TT. 1985. Effect of flooding of soil on growth and subsequent responses of *Taxodium distichum* seedlings to SO<sub>2</sub>. *Environ. Pollut. (A Ecol. Biol.)* 38: 199-212.E
- Siegel BZ, Lasconia M, Yaeger E, Siegel SM. 1984. The phytotoxicity of mercury vapor. *Water, air and soil pollution* 23: 15-24.
- St Louis VL, Rudd JWM, Kelly CA, Beaty KG, Bloom NS, Flett RJ. 1994. Importance of wetlands as sources of methyl mercury to boreal forest ecosystems. *Canadian Journal of Fisheries and Aquatic Sciences* 51: 1065-1076.
- Taylor OC et al. 1975. Oxides of nitrogen. In: Responses of plants to air pollution. JB Mudd and TT Kozlowski (eds.).
- Taylor OC, MacLean DC. 1970. Nitrogen oxides and peroxyacyl nitrates. In: Recognition air pollution injury to vegetation: A pictorial atlas; pp. E1-E14. JS Jacobsen, editor. Air Pollution Control Association, Pittsburgh, PA.
- Thimonier A, Dupouey JL, Bost F, Becker M. 1994. Simultaneous eutrophication and acidification of a forest ecosystem in north-east France. *New Phytologist* 3: 533-539.

- Treshow M, Anderson FK. 1989. Plant stress from air pollution, John Wiley and Sons Ltd.
- United States Fish and Wildlife Service. 2006(a). Okefenokee National Wildlife Refuge comprehensive conservation plan. Southeast Region. Atlanta, Georgia.
- United States Fish and Wildlife Service. 2006(b). St. Marks National Wildlife Refuge comprehensive conservation plan and environmental assessment.
- Varshney CK, Garg JK. 1979. Plant responses to sulfur dioxide pollution. CRC Critical Reviews in Environmental Control.
- Westman, WF et al. 1985. SO<sub>2</sub> effects on the growth of native plants. In: Sulfur dioxide and vegetation, pp. 264-280. WE Winner et al., editors. Sanford University Press, Sanford, CA.
- Wetmore CM. 1983. Lichens of the air quality Class I National Parks. Final Report. NPS Contract CX-0001-2-0034.
- Winger PW. 1997. Fate of airborne contaminants in Okefenokee National Wildlife Refuge. U.S. Department of the Interior. Geological Survey, Biological Resources Division. University of Georgia, Athens, Georgia.
- World Health Organization. 2000. Air quality guidelines for Europe. 2<sup>nd</sup> edition. 288 pages.
- Wright LM, Lockaby SG, Meldahl R, Thornton F, Chappelka AH. 1991. The influence of acid precipitation and ozone on nitrogen nutrition of young loblolly pine. *Water, air, and soil pollution* 5.

## Appendix A - Polk Power Station Unit 6 IGCC Emission Rate Calculations List of Tables

Table No.	Description
<b>Operation Sources</b>	
A-1	Unit 6 Annual Emission Rate Summary
A-2	CT/HRSG Operating Cases
A-3	CT/HRSG Emission Rates; NO <sub>x</sub> , SO <sub>2</sub> , CO, VOC, PM <sub>10</sub> , and Pb - Syngas
A-4	CT/HRSG Emission Rates; H <sub>2</sub> SO <sub>4</sub> Mist, Hg, NH <sub>3</sub> , and CO <sub>2</sub> - Syngas
A-5	CT/HRSG Emission Rates; NO <sub>x</sub> , SO <sub>2</sub> , CO, VOC, PM <sub>10</sub> , and Pb - Natural Gas
A-6	CT/HRSG Emission Rates; H <sub>2</sub> SO <sub>4</sub> Mist, Hg, NH <sub>3</sub> , and CO <sub>2</sub> - Natural Gas
A-7	CT/HRSG Hazardous Air Pollutant Emission Rates - Syngas
A-8	CT/HRSG Hazardous Air Pollutant Emission Rates - Natural Gas
A-9A	CT/HRSG Startup/Shutdown Emission Rates - Year 1
A-9B	CT/HRSG Startup/Shutdown Emission Rates - Year 4+ (Mature Facility)
A-10	Sulfuric Acid Plant Emission Rates
A-11	Sulfuric Acid Plant Startup/Shutdown Emission Rates
A-12	Auxiliary Boiler Emission Rates - Criteria Pollutants
A-13	Auxiliary Boiler Emission Rates - Hazardous Air Pollutants
A-14	Gasifier Preheat Stack Emission Rates
A-15A	Flare Emission Rates - Year 1
A-15B	Flare Emission Rates - Year 4+ (Mature Facility)
A-16	Emergency Firewater Pump Diesel Engines Emission Rates - Criteria Pollutants
A-17	Emergency Firewater Pump Diesel Engines Emission Rates - Hazardous Air Pollutants
A-18	Emergency Generator Diesel Engine Emission Rates - Criteria Pollutants
A-19	Emergency Generator Diesel Engine Emission Rates - Hazardous Air Pollutants
A-20	Cooling Tower PM/PM <sub>10</sub> Emission Rates

## Appendix A - Polk Power Station Unit 6 IGCC Emission Rate Calculations List of Tables (continued)

Table No.	Description
<b>Operation Sources</b>	
A-21	Cooling Tower PM/PM <sub>10</sub> Fractions
A-22	Storage Pile PM/PM <sub>10</sub> Emission Rates
A-23	Material Handling Point Source PM/PM <sub>10</sub> Emission Rates
A-24	Material Handling Fugitive Source PM <sub>10</sub> Emission Rates
A-25	Material Handling Fugitive Source PM Emission Rates
A-26	Gasifier Feedstock Flow Rates
A-27	CT/HRSG Fuel Flow Rates - Syngas
A-28	CT/HRSG Fuel Flow Rates - Natural Gas
A-29	CT/HRSG Exhaust Flow Rates - Syngas
A-30	CT/HRSG Exhaust Flow Rates - Natural Gas
<b>Construction Activities</b>	
A-31	Construction Excavation and Fill Operations PM/ PM <sub>10</sub> Emission Rates
A-32	Construction Grading and Earth Moving Operations PM <sub>10</sub> Emission Rates
A-33	Construction Unpaved Roads PM <sub>10</sub> Emission Rates
A-34	Construction Wind Erosion PM <sub>10</sub> Emission Rates
A-35	Construction Diesel Engine Emission Rates
<b>Stack Parameters</b>	
A-36	CT/HRSG Units - Stack Parameters (Syngas)
A-37	CT/HRSG Units - Stack Parameters (Natural Gas)
A-38	Auxiliary Boiler, Emergency Diesel Engines, Sulfuric Acid Plant, and Cooling Tower Stack Parameters

Source: ECT, 2007.

**Table A-1. Polk Power Station Unit 6 IGCC  
Annual Emission Rate Summary**

Pollutant	Potential Annual Emissions (tpy)															Unit 6 Totals
	CT/HRSG Train 1	CT/HRSG Train 2	CT/HRSG Startup/Shutdown	Sulfuric Acid plant	Sulfuric Acid plant Startup/Shutdown	Auxiliary Boiler	Gasifier Preheat Train 1	Gasifier Preheat Train 2	Flare	Emergency Firewater Pump Diesel Engines	Emergency Generator Diesel Engine	Cooling Tower	Feedstock & Slag Storage Piles	Feedstock Handling Point Sources	Feedstock Handling Fugitive Sources	
Criteria Pollutants																
NO <sub>x</sub>	433.6	433.6	44.6	Neg.	0.78	4.7	0.90	0.90	3.8	0.72	1.16	N/A	N/A	N/A	N/A	<b>924.8</b>
CO	407.3	407.3	71.2	Neg.	0.66	4.7	0.76	0.76	16.0	0.24	0.63	N/A	N/A	N/A	N/A	<b>909.6</b>
VOC	14.5	14.5	7.2	Neg.	0.043	1.4	0.050	0.050	0.052	0.11	0.078	N/A	N/A	N/A	N/A	<b>37.9</b>
SO <sub>2</sub>	227.8	227.8	0.61	160.6	1.31	0.77	0.054	0.054	51.2	0.00051	0.0013	N/A	N/A	N/A	N/A	<b>670.1</b>
PM <sub>10</sub> (filterable + condensable)	170.8	170.8	4.2	16.1	0.060	1.0	0.069	0.069	0.073	0.037	0.036	0.60	0.74	1.9	1.2	<b>367.6</b>
Pb	0.054	0.054	Neg.	Neg.	N/A	Neg.	Neg.	Neg.	Neg.	Neg.	Neg.	N/A	N/A	N/A	N/A	<b>0.11</b>
Hazardous Air Pollutants <sup>1</sup>																
Hydrogen Chloride	1.1	1.1	Neg.	Neg.	Neg.	Neg.	Neg.	Neg.	Neg.	Neg.	Neg.	N/A	N/A	N/A	N/A	<b>2.3</b>
Total HAPs	2.9	2.9	Neg.	Neg.	Neg.	Neg.	Neg.	Neg.	Neg.	Neg.	Neg.	N/A	N/A	N/A	N/A	<b>5.8</b>
Other Pollutants																
H <sub>2</sub> SO <sub>4</sub> Mist	53.4	53.4	0.057	16.1	0.13	Neg.	Neg.	Neg.	Neg.	Neg.	Neg.	N/A	N/A	N/A	N/A	<b>123.1</b>
PM (filterable)	78.8	78.8	4.2	16.1	0.06	1.0	Neg.	Neg.	0.073	0.037	0.036	25.8	1.5	1.9	2.5	<b>210.8</b>
NH <sub>3</sub>	89.0	89.0	N/A	Neg.	Neg.	Neg.	Neg.	Neg.	Neg.	Neg.	Neg.	N/A	N/A	N/A	N/A	<b>178.0</b>
CO <sub>2</sub>	2,628,282	2,628,282	Neg.	219,024	Neg.	15,459	Neg.	Neg.	Neg.	48	128	N/A	N/A	N/A	N/A	<b>5,491,223</b>
Hg (lb/yr)	26.9	26.9	Neg.	Neg.	Neg.	Neg.	Neg.	Neg.	Neg.	Neg.	Neg.	N/A	N/A	N/A	N/A	<b>53.8</b>

N/A - not applicable  
Neg. - negligible

<sup>1</sup> HAP emission rates when firing syngas.

Sources: ECT, 2007.  
GE, 2007.  
TEC, 2007.  
Bechtel, 2007.

**Table A-2. Polk Power Station Unit 6 IGCC  
CT/HRSG Operating Cases (Per CT/HRSG Unit)**

**A. Syngas**

Case No.	Ambient Temperature (°F)	CT/HRSG - Syngas			Annual Profile #1 (hr/yr)
		Load			
		100 %	80 %	60 %	
1 - Syn	0	✓			
2 - Syn	0		✓		
3 - Syn	0			✓	
4 - Syn	59	✓			8,760
5 - Syn	59		✓		
6 - Syn	59			✓	
7 - Syn	100	✓			
8 - Syn	100		✓		
9 - Syn	100			✓	

**B. Natural Gas**

Case No.	Ambient Temperature (°F)	CT/HRSG - Natural Gas			Annual Profile #2 (hr/yr)
		Load			
		100 %	80 %	60 %	
1 - NG	0	✓			
2 - NG	0		✓		
3 - NG	0			✓	
4 - NG	59	✓			8,760
5 - NG	59		✓		
6 - NG	59			✓	
7 - NG	100	✓			
8 - NG	100		✓		
9 - NG	100			✓	

Note: CTs will include equipment for compressor inlet air evaporative cooling.

Sources: ECT, 2007.  
TEC, 2007.



**Table A-3. Polk Power Station Unit 6 IGCC; CT/HRSG Emissions (Per CT/HRSG Unit)**  
**NO<sub>x</sub>, SO<sub>2</sub>, CO, VOC, PM<sub>10</sub>, and Pb Emission Rates - Syngas**

Pollutant	Averaging Period	Units	Operating Case									Maximums
			1 - Syn 0° F Amb. 100% Load	2 - Syn 0° F Amb. 80% Load	3 - Syn 0° F Amb. 60% Load	4 - Syn 59° F Amb. 100% Load	5 - Syn 59° F Amb. 80% Load	6 - Syn 59° F Amb. 60% Load	7 - Syn 100° F Amb. 100% Load	8 - Syn 100° F Amb. 80% Load	9 - Syn 100° F Amb. 60% Load	
			Operating Hours	Annual	hrs/yr	8,760	8,760	8,760	8,760	8,760	8,760	
Output <sup>1</sup>	Maximum	MW, gross	413.3	341.4	275.5	408.0	336.8	268.7	398.5	308.4	245.0	413.3
Gasifier Heat Input <sup>2</sup>	Max. Hourly	10 <sup>6</sup> Btu/hr (HHV)	3,200	2,691	2,265	3,073	2,577	2,138	3,047	2,373	1,982	3,200
CT Heat Input	Max. Hourly	10 <sup>6</sup> Btu/hr (HHV)	2,571	2,162	1,820	2,469	2,071	1,718	2,448	1,907	1,593	2,571
NO <sub>x</sub>	30-day	lb / 10 <sup>6</sup> Btu <sup>2</sup>	0.031	0.029	0.028	0.032	0.029	0.028	0.031	0.028	0.028	0.032
		lb / MWh, gross	0.24	0.23	0.23	0.24	0.22	0.22	0.23	0.22	0.22	0.24
	Rolling	ppmvd @ 15% O <sub>2</sub>	9.1	9.0	9.0	9.0	9.1	9.1	8.6	9.1	9.1	9.1
	tpy	N/A	N/A	N/A	433.6	N/A	N/A	N/A	N/A	N/A	N/A	433.6
	lb/hr	100	77	64	99	74	60	93	67	55	100	
g/s	12.6	9.7	8.1	12.5	9.3	7.6	11.7	8.4	6.9	12.6		
SO <sub>2</sub>	30-day	lb / 10 <sup>6</sup> Btu <sup>2</sup>	0.017	0.017	0.017	0.017	0.017	0.017	0.016	0.017	0.017	0.017
		lb / MWh, gross	0.13	0.13	0.14	0.13	0.13	0.13	0.12	0.13	0.14	0.14
	Rolling	ppmvd @ 15% O <sub>2</sub>	3.5	3.9	3.9	3.4	3.9	3.9	3.2	3.9	4.0	4.0
	tpy	N/A	N/A	N/A	227.8	N/A	N/A	N/A	N/A	N/A	N/A	227.8
	lb/hr	54	46	38	52	44	36	48	40	34	54	
g/s	6.80	5.80	4.79	6.55	5.54	4.54	6.05	5.04	4.28	6.80		
CO	24-Hour	lb / 10 <sup>6</sup> Btu <sup>2</sup>	0.029	0.029	0.030	0.030	0.030	0.031	0.029	0.030	0.032	0.032
		lb / MWh, gross	0.23	0.23	0.24	0.23	0.23	0.25	0.22	0.23	0.26	0.26
	Rolling	ppmvd @ 15% O <sub>2</sub>	14.0	15.1	15.6	13.9	15.5	16.4	13.2	16.0	17.4	17.4
	tpy	N/A	N/A	N/A	407.3	N/A	N/A	N/A	N/A	N/A	N/A	407.3
	lb/hr	94	79	67	93	77	66	87	72	64	94	
g/s	11.84	9.95	8.44	11.72	9.70	8.32	10.96	9.07	8.06	11.84		
VOC (As CH <sub>4</sub> )	3-hr	lb / 10 <sup>6</sup> Btu <sup>2</sup>	0.0010	0.0010	0.0011	0.0011	0.0010	0.0011	0.0010	0.0011	0.0012	0.0012
		lb / MWh, gross	0.0080	0.0082	0.0087	0.0081	0.0080	0.0086	0.0078	0.0084	0.0094	0.0094
	Rolling	ppmvd @ 15% O <sub>2</sub>	0.9	0.9	1.0	0.9	1.0	1.0	0.8	1.0	1.1	1.1
	tpy	N/A	N/A	N/A	14.5	N/A	N/A	N/A	N/A	N/A	N/A	14.5
	lb/hr	3.3	2.8	2.4	3.3	2.7	2.3	3.1	2.6	2.3	3.3	
g/s	0.42	0.35	0.30	0.42	0.34	0.29	0.39	0.33	0.29	0.42		
PM <sub>10</sub> (filterable)	3-Hr	lb / 10 <sup>6</sup> Btu <sup>2</sup>	0.0056	0.0067	0.0079	0.0059	0.0070	0.0084	0.0059	0.0076	0.0091	0.0091
		lb / MWh, gross	0.044	0.053	0.065	0.044	0.053	0.067	0.045	0.058	0.073	0.073
	tpy	N/A	N/A	N/A	78.8	N/A	N/A	N/A	N/A	N/A	78.8	
	lb/hr	18	18	18	18	18	18	18	18	18	18	
	g/s	2.27	2.27	2.27	2.27	2.27	2.27	2.27	2.27	2.27	2.27	
PM <sub>10</sub> (condensable)	3-Hr	lb / 10 <sup>6</sup> Btu <sup>2</sup>	0.0066	0.0078	0.0088	0.0068	0.0081	0.0094	0.0069	0.0084	0.0101	0.010
		lb / MWh, gross	0.051	0.062	0.073	0.051	0.062	0.074	0.053	0.065	0.082	0.082
	tpy	N/A	N/A	N/A	92.0	N/A	N/A	N/A	N/A	N/A	92.0	
	lb/hr	21	21	20	21	21	20	21	20	20	21	
	g/s	2.65	2.65	2.52	2.65	2.65	2.52	2.65	2.52	2.52	2.65	
PM <sub>10</sub> (total)	3-Hr	lb / 10 <sup>6</sup> Btu <sup>2</sup>	0.012	0.014	0.017	0.013	0.015	0.018	0.013	0.016	0.019	0.019
		lb / MWh, gross	0.094	0.114	0.138	0.096	0.116	0.141	0.098	0.123	0.155	0.155
	tpy	N/A	N/A	N/A	170.8	N/A	N/A	N/A	N/A	N/A	170.8	
	lb/hr	39	39	38	39	39	38	39	38	38	39	
	g/s	4.91	4.91	4.79	4.91	4.91	4.79	4.91	4.79	4.79	4.91	
Pb	N/A	lb / 10 <sup>12</sup> Btu <sup>2</sup>	4.00	4.00	4.00	4.00	4.00	4.00	4.00	4.00	4.00	4.00
		lb / MWh, gross	0.000031	0.000032	0.000033	0.000030	0.000031	0.000032	0.000031	0.000031	0.000032	0.000033
	tpy	N/A	N/A	N/A	0.054	N/A	N/A	N/A	N/A	N/A	0.054	
	lb/hr	0.0128	0.0108	0.0091	0.0123	0.0103	0.0086	0.0122	0.0095	0.0079	0.0128	
	g/s	0.00161	0.00136	0.00114	0.00155	0.00130	0.00108	0.00154	0.00120	0.00100	0.00161	

<sup>1</sup> CT output plus 50% of common steam turbine output.

<sup>2</sup> Fresh feedstock heat input to one gasifier.

Sources: ECT, 2007.  
 GE, 2007.  
 TEC, 2007.

**Table A-4. Polk Power Station Unit 6 IGCC; CT/HRSG Emissions (Per CT/HRSG Unit)  
H<sub>2</sub>SO<sub>4</sub> Mist, Hg, NH<sub>3</sub>, and CO<sub>2</sub> Emission Rates - Syngas**

Pollutant	Averaging Period	Units	Operating Case									Maximums	
			1 - Syn	2 - Syn	3 - Syn	4 - Syn	5 - Syn	6 - Syn	7 - Syn	8 - Syn	9 - Syn		
			0° F Amb. 100% Load	0° F Amb. 80% Load	0° F Amb. 60% Load	59° F Amb. 100% Load	59° F Amb. 80% Load	59° F Amb. 60% Load	100° F Amb. 100% Load	100° F Amb. 80% Load	100° F Amb. 60% Load		
Operating Hours	Annual	hrs/yr	8,760	8,760	8,760	8,760	8,760	8,760	8,760	8,760	8,760	8,760	8,760
Output <sup>1</sup>	Maximum	MW, gross	413.3	341.4	275.5	408.0	336.8	268.7	398.5	308.4	245.0	413.3	413.3
Gasifier Heat Input <sup>2</sup>	Max. Hourly	10 <sup>6</sup> Btu/hr (HHV)	3,200	2,691	2,265	3,073	2,577	2,138	3,047	2,373	1,982	3,200	3,200
CT Heat Input	Max. Hourly	10 <sup>6</sup> Btu/hr (HHV)	2,571	2,162	1,820	2,469	2,071	1,718	2,448	1,907	1,593	2,571	2,571
H <sub>2</sub> SO <sub>4</sub> Mist	3-Hr	lb / 10 <sup>6</sup> Btu <sup>2</sup>	0.0040	0.0039	0.0040	0.0040	0.0040	0.0039	0.0037	0.0040	0.0039	0.0040	0.0040
		lb / MWh, gross	0.031	0.031	0.033	0.030	0.030	0.031	0.029	0.030	0.032	0.033	0.033
		tpy	N/A	N/A	N/A	53.4	N/A	N/A	N/A	N/A	N/A	N/A	53.4
		lb/hr	12.8	10.6	9.0	12.2	10.2	8.4	11.4	9.4	7.8	12.8	12.8
		g/s	1.6	1.3	1.1	1.5	1.3	1.1	1.4	1.2	1.0	1.6	1.6
Hg	Annual	lb / 10 <sup>12</sup> Btu	1.0	1.0	1.0	1.0	1.0	1.0	1.0	1.0	1.0	1.0	1.0
		lb x 10 <sup>6</sup> / MWh, gross	7.7	7.9	8.2	7.5	7.7	6.0	7.6	7.7	8.1	8.2	8.2
		tpy	N/A	N/A	N/A	0.013	N/A	N/A	N/A	N/A	N/A	0.013	0.013
		lb/yr	N/A	N/A	N/A	26.9	N/A	N/A	N/A	N/A	N/A	26.9	26.9
		lb/hr	0.0032	0.0027	0.0023	0.0031	0.0026	0.0021	0.0030	0.0024	0.0020	0.0032	0.0032
NH <sub>3</sub>	3-Hr	lb / 10 <sup>6</sup> Btu <sup>2</sup>	0.0064	0.0059	0.0058	0.0066	0.0058	0.0057	0.0066	0.0058	0.0056	0.0066	0.0066
		lb / MWh, gross	0.049	0.046	0.047	0.050	0.045	0.046	0.050	0.044	0.046	0.050	0.050
		ppmvd @ 15% O <sub>2</sub>	5.0	5.0	5.0	5.0	5.0	5.0	5.0	5.0	5.0	5.0	5.0
		tpy	N/A	N/A	N/A	89.0	N/A	N/A	N/A	N/A	N/A	89.0	89.0
		lb/hr	20.4	15.8	13.1	20.3	15.1	12.2	20.0	13.7	11.2	20.4	20.4
CO <sub>2</sub> <sup>3</sup>	N/A	g/s	2.6	2.0	1.6	2.6	1.9	1.5	2.5	1.7	1.4	2.6	2.6
		lb / 10 <sup>6</sup> Btu <sup>2</sup>	203.4	203.4	203.4	203.4	203.4	203.4	203.4	203.4	203.4	203.4	203.4
		lb / MWh, gross	1,575	1,604	1,673	1,532	1,557	1,619	1,555	1,565	1,646	1,673	1,673
		tpy <sup>4</sup>	N/A	N/A	N/A	2,628,282	N/A	N/A	N/A	N/A	N/A	2,628,282	2,628,282
		lb/hr <sup>4</sup>	624,819	525,484	442,319	600,064	503,323	417,589	594,977	463,306	387,038	624,819	624,819

<sup>1</sup> CT output plus 50% of common steam turbine output

<sup>2</sup> Fresh feedstock heat input to one gasifier

<sup>3</sup> 100% design coal, assume complete oxidation of feedstock carbon to CQ.

<sup>4</sup> Approximately 96% of total CO<sub>2</sub> will be emitted from the CT/HRSG stacks, with the remaining 4% emitted from the sulfuric acid plant stack..

Sources: ECT, 2007.  
GE, 2007.  
TEC, 2007.

**Table A-5. Polk Power Station Unit 6 IGCC; CT/HRSG Emissions (Per CT/HRSG Unit)**  
**NO<sub>x</sub>, SO<sub>2</sub>, CO, VOC, PM<sub>10</sub>, and Pb Emission Rates - Natural Gas**

Pollutant	Averaging Period	Units	Operating Case									Maximums	
			1 - NG	2 - NG	3 - NG	4 - NG	5 - NG	6 - NG	7 - NG	8 - NG	9 - NG		
			0° F Amb. 100% Load	0° F Amb. 80% Load	0° F Amb. 60% Load	59° F Amb. 100% Load	59° F Amb. 80% Load	59° F Amb. 60% Load	100° F Amb. 100% Load	100° F Amb. 80% Load	100° F Amb. 60% Load		
Operating Hours	Annual	hrs/yr	8,760	8,760	8,760	8,760	8,760	8,760	8,760	8,760	8,760	8,760	
Output <sup>1</sup>	Maximum	MW, gross	267.0	228.0	185.3	247.4	210.7	170.3	235.3	188.6	151.2	267.0	
CT Heat Input	Max. Hourly	10 <sup>6</sup> Btu/hr (HHV)	1,980	1,710	1,448	1,804	1,572	1,323	1,735	1,438	1,207	1,980	
NO <sub>x</sub>	30-day	lb / 10 <sup>6</sup> Btu	0.018	0.019	0.019	0.018	0.018	0.018	0.017	0.018	0.018	0.019	
		lb / MWh, gross	0.13	0.14	0.15	0.13	0.14	0.14	0.13	0.14	0.14	0.15	
	Rolling	ppmvd @ 15% O <sub>2</sub>	5.0	5.1	5.1	5.0	5.0	4.9	4.7	4.9	5.0	5.1	
		tpy	N/A	N/A	N/A	144.5	N/A	N/A	N/A	N/A	N/A	N/A	144.5
		lb/hr	36	32	27	33	29	24	30	26	22	36	
g/s	4.5	4.0	3.4	4.2	3.7	3.0	3.8	3.3	2.8	4.5			
SO <sub>2</sub> <sup>2</sup>	N/A	lb / 10 <sup>6</sup> Btu	0.0056	0.0056	0.0056	0.0056	0.0056	0.0056	0.0056	0.0056	0.0056	0.0056	
		lb / MWh, gross	0.04	0.042	0.044	0.041	0.042	0.044	0.041	0.043	0.045	0.045	
	ppmvd @ 15% O <sub>2</sub>	1.1	1.1	1.1	1.1	1.1	1.1	1.1	1.1	1.1	1.1		
		tpy	N/A	N/A	N/A	44.3	N/A	N/A	N/A	N/A	N/A	44.3	
		lb/hr	11.1	9.6	8.1	10.1	8.8	7.4	9.7	8.1	6.8	11.1	
g/s	1.4	1.2	1.0	1.3	1.1	0.9	1.2	1.0	0.9	1.4			
CO	24-Hour	lb / 10 <sup>6</sup> Btu	0.045	0.042	0.042	0.045	0.043	0.045	0.042	0.044	0.047	0.047	
		lb / MWh, gross	0.34	0.32	0.33	0.33	0.32	0.35	0.31	0.33	0.38	0.38	
	Rolling	ppmvd @ 15% O <sub>2</sub>	20.3	18.9	18.9	20.1	19.4	20.0	18.9	19.6	21.2	21.2	
		tpy	N/A	N/A	N/A	354.8	N/A	N/A	N/A	N/A	N/A	354.8	
		lb/hr	90	72	61	81	68	59	73	63	57	90	
g/s	11.3	9.1	7.7	10.2	8.6	7.4	9.2	7.9	7.2	11.3			
VOC (As CH <sub>4</sub> )	3-hr	lb / 10 <sup>6</sup> Btu	0.0017	0.0016	0.0015	0.0017	0.0016	0.0017	0.0016	0.0017	0.0017	0.0017	
		lb / MWh, gross	0.012	0.012	0.012	0.012	0.012	0.013	0.012	0.013	0.014	0.014	
	ppmvd @ 15% O <sub>2</sub>	1.3	1.2	1.2	1.3	1.2	1.3	1.3	1.3	1.3	1.4		
		tpy	N/A	N/A	N/A	13.1	N/A	N/A	N/A	N/A	N/A	13.1	
		lb/hr	3.3	2.7	2.2	3.0	2.5	2.2	2.8	2.4	2.1	3.3	
g/s	0.42	0.34	0.28	0.38	0.31	0.28	0.35	0.30	0.26	0.42			
PM <sub>10</sub> (filterable)	3-Hr	lb / 10 <sup>6</sup> Btu	0.0045	0.0053	0.0062	0.0050	0.0057	0.0068	0.0052	0.0063	0.0075	0.0075	
		lb / MWh, gross	0.034	0.039	0.049	0.036	0.043	0.053	0.038	0.048	0.060	0.060	
	tpy	N/A	N/A	N/A	39.4	N/A	N/A	N/A	N/A	N/A	N/A	39.4	
		lb/hr	9	9	9	9	9	9	9	9	9	9	
		g/s	1.1	1.1	1.1	1.1	1.1	1.1	1.1	1.1	1.1	1.1	
PM <sub>10</sub> (condensable)	3-Hr	lb / 10 <sup>6</sup> Btu	0.0045	0.0053	0.0062	0.0050	0.0057	0.0068	0.0052	0.0063	0.0075	0.0075	
		lb / MWh, gross	0.034	0.039	0.049	0.036	0.043	0.053	0.038	0.048	0.060	0.060	
	tpy	N/A	N/A	N/A	39.4	N/A	N/A	N/A	N/A	N/A	N/A	39.4	
		lb/hr	9	9	9	9	9	9	9	9	9	9	
		g/s	1.1	1.1	1.1	1.1	1.1	1.1	1.1	1.1	1.1	1.1	
PM <sub>10</sub> (total)	3-Hr	lb / 10 <sup>6</sup> Btu	0.0091	0.0105	0.0124	0.0100	0.0115	0.0136	0.0104	0.0125	0.0149	0.015	
		lb / MWh, gross	0.067	0.079	0.097	0.073	0.085	0.106	0.077	0.095	0.119	0.119	
	tpy	N/A	N/A	N/A	78.8	N/A	N/A	N/A	N/A	N/A	N/A	78.8	
		lb/hr	18	18	18	18	18	18	18	18	18	18	
		g/s	2.3	2.3	2.3	2.3	2.3	2.3	2.3	2.3	2.3	2.3	
Pb <sup>3</sup>	N/A	lb / 10 <sup>12</sup> Btu	0.49	0.49	0.49	0.49	0.49	0.49	0.49	0.49	0.49	0.49	
		lb / MWh, gross	3.64E-06	3.68E-06	3.83E-06	3.57E-06	3.66E-06	3.81E-06	3.62E-06	3.74E-06	3.91E-06	3.91E-06	
	tpy	N/A	N/A	N/A	0.0039	N/A	N/A	N/A	N/A	N/A	N/A	0.0039	
		lb/hr	0.0010	0.0008	0.0007	0.0009	0.0008	0.0006	0.0009	0.0007	0.0006	0.0010	
		g/s	0.00012	0.00011	0.00009	0.00011	0.00010	0.00008	0.00011	0.00009	0.00007	0.00012	

<sup>1</sup> CT output plus 50% of common steam turbine output.

<sup>2</sup> Natural gas sulfur content of 2.0 grains S per 100 scf per FDEP guidance.

<sup>3</sup> Natural Gas Combustion, Table 1.4-2, AP-42, 3/98.

Sources: ECT, 2007.  
 GE, 2007.  
 TEC, 2007.

**Table A-6. Polk Power Station Unit 6 IGCC; CT/HRSG Emissions (Per CT/HRSG Unit)  
H<sub>2</sub>SO<sub>4</sub> Mist, Hg, NH<sub>3</sub>, and CO<sub>2</sub> Emission Rates - Natural Gas**

Pollutant	Averaging Period	Units	Operating Case									Maximums	
			1 - NG 0° F Amb.	2 - NG 0° F Amb.	3 - NG 0° F Amb.	4 - NG 59° F Amb.	5 - NG 59° F Amb.	6 - NG 59° F Amb.	7 - NG 100° F Amb.	8 - NG 100° F Amb.	9 - NG 100° F Amb.		
			100% Load	80% Load	60% Load	100% Load	80% Load	60% Load	100% Load	80% Load	60% Load		
Operating Hours	Annual	hrs/yr	8,760	8,760	8,760	8,760	8,760	8,760	8,760	8,760	8,760	8,760	
Output <sup>1</sup>	Maximum	MW, gross	267.0	228.0	185.3	247.4	210.7	170.3	235.3	188.6	151.2	267.0	
CT Heat Input	Max. Hourly	10 <sup>6</sup> Btu/hr (HHV)	1,980	1,710	1,448	1,804	1,572	1,323	1,735	1,438	1,207	1,980	
H <sub>2</sub> SO <sub>4</sub> Mist <sup>2</sup>	3-Hr	lb / 10 <sup>6</sup> Btu	0.00086	0.00086	0.00086	0.00086	0.00086	0.00086	0.00086	0.00086	0.00086	0.00086	0.00086
		lb / MWh, gross	0.0064	0.0064	0.0067	0.0063	0.0064	0.0067	0.0063	0.0065	0.0069	0.0069	0.0069
		tpy	N/A	N/A	N/A	6.6	N/A	N/A	N/A	N/A	N/A	N/A	6.8
		lb/hr	1.7	1.5	1.2	1.5	1.3	1.1	1.5	1.2	1.0	1.0	1.7
		g/s	0.21	0.18	0.16	0.19	0.17	0.14	0.19	0.16	0.13	0.13	0.21
Hg <sup>3</sup>	Annual	lb / 10 <sup>12</sup> Btu	0.25	0.25	0.25	0.25	0.25	0.25	0.25	0.25	0.25	0.25	0.25
		lb x 10 <sup>6</sup> / MWh, gross	1.9	1.9	2.0	1.9	1.9	2.0	1.9	1.9	2.0	2.0	2.0
		tpy	N/A	N/A	N/A	0.0020	N/A	N/A	N/A	N/A	N/A	N/A	0.0020
		lb/hr	0.00050	0.00044	0.00037	0.00048	0.00040	0.00034	0.00044	0.00037	0.00031	0.00031	0.00050
		g/s	0.000064	0.000055	0.000046	0.000058	0.000050	0.000042	0.000056	0.000046	0.000039	0.000039	0.000064
NH <sub>3</sub>	3-Hr	lb / 10 <sup>6</sup> Btu	0.0068	0.0068	0.0068	0.0068	0.0068	0.0068	0.0068	0.0068	0.0068	0.0068	0.0068
		lb / MWh, gross	0.050	0.051	0.053	0.049	0.051	0.053	0.050	0.052	0.054	0.054	0.054
		ppmvd @ 15% O <sub>2</sub>	5.0	5.0	5.0	5.0	5.0	5.0	5.0	5.0	5.0	5.0	5.0
		tpy	N/A	N/A	N/A	53.6	N/A	N/A	N/A	N/A	N/A	N/A	53.6
		lb/hr	13.4	11.6	9.6	12.2	10.7	9.0	11.8	9.7	8.2	8.2	13.4
CO <sub>2</sub> <sup>4</sup>	N/A	lb / 10 <sup>6</sup> Btu	117.6	117.6	117.6	117.6	117.6	117.6	117.6	117.6	117.6	117.6	117.6
		lb / MWh, gross	872.6	882.3	919.3	857.8	877.5	913.8	867.7	896.9	939.6	939.6	939.6
		tpy	N/A	N/A	N/A	929,629	N/A	N/A	N/A	N/A	N/A	N/A	929,629
		lb/hr	232,956	201,180	170,328	212,244	184,920	155,592	204,120	169,164	142,056	142,056	232,956
		g/s	29,352	25,348	21,461	26,742	23,300	19,604	25,719	21,314	17,899	17,899	29,352

<sup>1</sup> CT output plus 50% of common steam turbine output

<sup>2</sup> 10% conversion of SO<sub>2</sub> to H<sub>2</sub>SO<sub>4</sub> on a volume basis.

<sup>3</sup> Natural Gas Combustion, Table 1.4-4, AP-42, 7/98

<sup>4</sup> Natural Gas Combustion, Table 1.4-2, AP-42, 7/98

Sources: ECT, 2007.

GE, 2007.

TEC, 2007.

**Table A-7. Polk Power Station Unit 6 IGCC (Per CT/HRSG Unit)  
Hazardous Air Pollutants - Syngas**

Parameter	Units	CT/HRSG Unit		
		100%, 0°F	100%, 59°F	100%, 100°F
Maximum Heat Input (HHV):	10 <sup>6</sup> Btu/hr	2,571	2,469	2,448
Maximum Annual Hours	hrs/yr	N/A	8,760	N/A

Pollutant	Emission Factor <sup>1,2</sup> (lb/10 <sup>12</sup> Btu)	Potential Emission Rates	
		(lb/hr)	(tpy)
2-Methylnaphthalene	0.3600	0.0009	0.0039
Acenaphthylene	0.0260	0.0001	0.0003
Acetaldehyde	1.8000	0.0046	0.0195
Antimony	3.9000	0.0100	0.0422
Arsenic	3.0000	0.0077	0.0324
Benzaldehyde	2.9000	0.0075	0.0314
Benzene	4.4000	0.0113	0.0476
Benzo(a)anthracene	0.0023	0.0000	0.0000
Benzo(e)pyrene	0.0055	0.0000	0.0001
Benzo(g,h,i)perylene	0.0095	0.0000	0.0001
Beryllium	0.9200	0.0024	0.0100
Cadmium	4.2000	0.0108	0.0454
Carbon Disulfide	45.0000	0.1157	0.4867
Chromium	3.8000	0.0098	0.0411
Cobalt	0.8100	0.0021	0.0088
Formaldehyde	17.0000	0.0437	0.1839
Hydrogen Chloride <sup>3</sup>	105.1889	0.2705	1.1377
Hydrogen Fluoride	56.0000	0.1440	0.6057
Lead	4.0000	0.0103	0.0433
Manganese	4.3000	0.0111	0.0465
Mercury <sup>3</sup>	1.2435	0.0032	0.0135
Naphthalene	0.4000	0.0010	0.0043
Nickel	5.6000	0.0144	0.0606
Selenium	4.3000	0.0111	0.0465
Maximum Individual HAP		0.2705	1.1377
Total HAPs		0.6921	2.9113

<sup>1</sup> Unless otherwise indicated, emission factors from *A Study of Toxic Emissions from a Coal-Fired Gasification Plant* Radian, December 1995.

<sup>2</sup> Based on syngas heat input to the CT.

<sup>3</sup> HCl and Hg emission factors based on Unit 6 project data.

Sources: ECT, 2007  
GE, 2007

**Table A-8. Polk Power Station Unit 6 IGCC (Per CT/HRSG Unit)  
Hazardous Air Pollutants - Natural Gas**

Parameter	Units	CT/HRSG Unit		
		100%, 0 °F	100%, 59 °F	100%, 100 °F
Maximum Heat Input (HHV):	10 <sup>6</sup> Btu/hr	1,980	1,804	1,735
Maximum Annual Hours:	hrs/yr	N/A	8,760	N/A

Pollutant	Emission Factor <sup>1</sup> (lb/10 <sup>12</sup> Btu)	Potential Emission Rates	
		(lb/hr)	(tpy)
1,3-Butadiene	0.4300	0.0009	0.0034
Acetaldehyde	40.0000	0.0792	0.3161
Acrolein	6.4000	0.0127	0.0506
Benzene	12.0000	0.0238	0.0948
Ethylbenzene	32.0000	0.0634	0.2529
Formaldehyde <sup>2</sup>	300.0000	0.5940	2.3706
Lead	0.4902	0.0010	0.0039
Naphthalene	1.3000	0.0026	0.0103
Polycyclic Aromatic Hydrocarbons (PAHs)	2.2000	0.0044	0.0174
Propylene Oxide	29.0000	0.0574	0.2292
Toluene	130.0000	0.2574	1.0272
Xylene	64.0000	0.1267	0.5057
Maximum Individual HAP		0.5940	2.3706
Total HAPs		1.2234	4.8819

<sup>1</sup> - EPA AP-42, Table 3.1-3, April 2000.

<sup>2</sup> - CT Factor is based on the average of EPA AP-42 test data for large, heavy duty CTs.

Sources: ECT, 2007  
GE, 2007

**Table A-9A. Polk Power Station Unit 6 IGCC  
CT/HRSG Controlled Startup/Shutdown Emission Rates: Year 1**

**A. Controlled Cold Startups (Year 1)**

Annual Startup Events (Per Train) 21 events/yr

Pollutant	CT/HRSG Cold Starts <sup>1,2</sup>					
	CT/HRSG Train 1		CT/HRSG Train 2		Trains 1 & 2	
	(lb/event)	(tpy)	(lb/event)	(tpy)	(lb/event)	(tpy)
PM <sub>10</sub>	330	3.5	37	0.39	367	3.9
CO	6,075	63.8	358	3.8	6,433	67.5
SO <sub>2</sub>	22	0.23	21	0.22	43	0.45
NO <sub>x</sub>	3,219	33.8	564	5.9	3,783	39.7
VOC	633	6.6	19	0.2	652	6.8
H <sub>2</sub> SO <sub>4</sub> Mist	1.7	0.018	1.7	0.018	3.4	0.036

<sup>1</sup> Startup on natural gas, transfer to syngas at minimum 30% CT load, ramp to 60% CT load, at 59°F ambient without SCR.

<sup>2</sup> During startups, Gasifier Train 1 will operate for approximately 18 hours, and Gasifier Train 2 for 2 hours.

**B. Controlled Hot Startups (Year 1)**

Annual Startup Events (Per Train) 5 events/yr

Pollutant	CT/HRSG Hot Starts <sup>3</sup>					
	CT/HRSG Train 1		CT/HRSG Train 2		Trains 1 & 2	
	(lb/event)	(tpy)	(lb/event)	(tpy)	(lb/event)	(tpy)
PM <sub>10</sub>	37	0.09	37	0.09	74	0.2
CO	396	1.0	358	0.9	754	1.9
SO <sub>2</sub>	8	0.02	21	0.05	29	0.07
NO <sub>x</sub>	364	0.9	564	1.4	928	2.3
VOC	19	0.048	19	0.048	38	0.1
H <sub>2</sub> SO <sub>4</sub> Mist	0.7	0.002	2.0	0.005	2.7	0.007

<sup>3</sup> Startup on natural gas, transfer to syngas at minimum 30% CT load, ramp to 60% CT load, at 59°F ambient without SCR.

**C. Controlled Shutdowns (Year 1)**

Annual Shutdown Events (Per Train) 21 events/yr (shutdowns occurring prior to a cold start)

Pollutant	CT/HRSG Shutdowns <sup>4</sup>					
	CT/HRSG Train 1		CT/HRSG Train 2		Trains 1 & 2	
	(lb/event)	(tpy)	(lb/event)	(tpy)	(lb/event)	(tpy)
PM <sub>10</sub>	5.5	0.06	5.5	0.06	11.0	0.12
CO	82.5	0.9	82.5	0.9	165.0	1.7
SO <sub>2</sub>	4.1	0.04	4.1	0.04	8.2	0.09
NO <sub>x</sub>	123.5	1.3	123.5	1.3	247.0	2.6
VOC	14.5	0.2	14.5	0.2	29.0	0.3
H <sub>2</sub> SO <sub>4</sub> Mist	0.7	0.007	0.7	0.007	1.4	0.015

<sup>4</sup> During shutdowns, each gasifier train will operate for approximately 2.5 hours.

**D. Total CT/HRSG Startup/Shutdown Emissions (Year 1)**

Pollutant	CT/HRSG Startup Shutdown Emissions (tpy)						
	Cold/Hot Starts		Shutdowns		Totals		
	Train 1	Train 2	Train 1	Train 2	Train 1	Train 2	Trains 1 & 2
PM <sub>10</sub>	3.56	0.48	0.06	0.06	3.62	0.54	4.2
CO	64.78	4.65	0.87	0.87	65.64	5.52	71.2
SO <sub>2</sub>	0.25	0.27	0.04	0.04	0.29	0.32	0.6
NO <sub>x</sub>	34.71	7.33	1.30	1.30	36.01	8.63	44.6
VOC	6.69	0.25	0.15	0.15	6.84	0.40	7.2
H <sub>2</sub> SO <sub>4</sub> Mist	0.020	0.023	0.007	0.007	0.027	0.030	0.057

Sources: ECT, 2007.  
GE, 2007.

**Table A-9B. Polk Power Station Unit 6 IGCC  
CT/HRSG Controlled Startup/Shutdown Emission Rates: Year 4+**

**A. Controlled Cold Startups (Year 4+)**

Annual Startup Events (Per Train) 8 events/yr

Pollutant	CT/HRSG Cold Starts <sup>1,2</sup>					
	CT/HRSG Train 1		CT/HRSG Train 2		Trains 1 & 2	
	(lb/event)	(tpy)	(lb/event)	(tpy)	(lb/event)	(tpy)
PM <sub>10</sub>	330	1.3	37	0.15	367	1.5
CO	6,075	24.3	358	1.4	6,433	25.7
SO <sub>2</sub>	22	0.09	21	0.08	43	0.17
NO <sub>x</sub>	3,219	12.9	564	2.3	3,783	15.1
VOC	633	2.5	19	0.1	652	2.6
H <sub>2</sub> SO <sub>4</sub> Mist	1.7	0.007	1.7	0.007	3.4	0.014

<sup>1</sup> Startup on natural gas, transfer to syngas at minimum 30% CT load, ramp to 60% CT load, at 59°F ambient without SCR.

<sup>2</sup> During startups, Gasifier Train 1 will operate for approximately 18 hours, and Gasifier Train 2 for 2 hours.

**B. Controlled Hot Startups (Year 4+)**

Annual Startup Events (Per Train) 8 events/yr

Pollutant	CT/HRSG Hot Starts <sup>3</sup>					
	CT/HRSG Train 1		CT/HRSG Train 2		Trains 1 & 2	
	(lb/event)	(tpy)	(lb/event)	(tpy)	(lb/event)	(tpy)
PM <sub>10</sub>	37	0.15	37	0.15	74	0.3
CO	396	1.6	358	1.4	754	3.0
SO <sub>2</sub>	8	0.03	21	0.08	29	0.12
NO <sub>x</sub>	364	1.5	564	2.3	928	3.7
VOC	19	0.076	19	0.076	38	0.2
H <sub>2</sub> SO <sub>4</sub> Mist	0.7	0.003	2.0	0.008	2.7	0.011

<sup>3</sup> Startup on natural gas, transfer to syngas at minimum 30% CT load, ramp to 60% CT load, at 59°F ambient without SCR.

**C. Controlled Shutdowns (Year 4+)**

Annual Shutdown Events (Per Train) 8 events/yr (shutdowns occurring prior to a cold start)

Pollutant	CT/HRSG Shutdowns <sup>4</sup>					
	CT/HRSG Train 1		CT/HRSG Train 2		Trains 1 & 2	
	(lb/event)	(tpy)	(lb/event)	(tpy)	(lb/event)	(tpy)
PM <sub>10</sub>	5.5	0.02	5.5	0.02	11.0	0.04
CO	82.5	0.3	82.5	0.3	165.0	0.7
SO <sub>2</sub>	4.1	0.02	4.1	0.02	8.2	0.03
NO <sub>x</sub>	123.5	0.5	123.5	0.5	247.0	1.0
VOC	14.5	0.1	14.5	0.1	29.0	0.1
H <sub>2</sub> SO <sub>4</sub> Mist	0.7	0.003	0.7	0.003	1.4	0.006

<sup>4</sup> During shutdowns, each gasifier train will operate for approximately 2.5 hours.

**D. Total CT/HRSG Startup/Shutdown Emissions (Year 4+)**

Pollutant	CT/HRSG Startup Shutdown Emissions (tpy)						
	Cold/Hot Starts		Shutdowns		Totals		
	Train 1	Train 2	Train 1	Train 2	Train 1	Train 2	Trains 1 & 2
PM <sub>10</sub>	1.47	0.30	0.02	0.02	1.49	0.32	1.8
CO	25.88	2.86	0.33	0.33	26.21	3.19	29.4
SO <sub>2</sub>	0.12	0.17	0.02	0.02	0.14	0.18	0.3
NO <sub>x</sub>	14.33	4.51	0.49	0.49	14.83	5.01	19.8
VOC	2.61	0.15	0.06	0.06	2.66	0.21	2.9
H <sub>2</sub> SO <sub>4</sub> Mist	0.010	0.015	0.003	0.003	0.012	0.018	0.030

Sources: ECT, 2007.  
GE, 2007.



<b>POTENTIAL EMISSION INVENTORY WORKSHEET</b>			<b>A-10</b>
Polk Power Station - Unit 6 IGCC			<b>SAP</b>
<b>EMISSION SOURCE TYPE</b>			
SULFURIC ACID PLANT - SO <sub>2</sub> and H <sub>2</sub> SO <sub>4</sub> Mist			
<b>FACILITY AND SOURCE DESCRIPTION</b>			
Emission Source Description:	Sulfuric Acid Plant (SAP)		
Emission Control Method(s)/ID No.(s):	Dual Absorption Contact Process and Mist Eliminators		
Emission Point Description:	6.4		
<b>EMISSION ESTIMATION EQUATIONS</b>			
Emission Rate (lb/hr) = Emission Factor (lb/ton 100% H <sub>2</sub> SO <sub>4</sub> Acid) x Rated Capacity (ton 100% H <sub>2</sub> SO <sub>4</sub> Acid/hr)			
Emission Rate (ton/yr) = Emission Factor (lb/ton 100% H <sub>2</sub> SO <sub>4</sub> Acid) x Rated Capacity (ton 100% H <sub>2</sub> SO <sub>4</sub> Acid/yr) x (1 ton/2,000 lb)			
<b>INPUT DATA AND EMISSIONS CALCULATIONS</b>			
Maximum Operating Hours	8,760	hrs/yr	
Maximum 100% H <sub>2</sub> SO <sub>4</sub> Acid Production Rate:	36.7	tons/hr	
	880.0	tons/day	
	321,200	tons/yr	
Pollutant	Emission Factors	Potential Emission Rates	
	(lb/ton 100% H <sub>2</sub> SO <sub>4</sub> Acid)	(lb/hr)	(tpy)
SO <sub>2</sub>	1.0	36.7	160.6
H <sub>2</sub> SO <sub>4</sub>	0.10	3.7	16.1
CO <sub>2</sub> (contained in acid gas)	N/A	N/A	219,024
<b>SOURCES OF INPUT DATA</b>			
Parameter	Data Source		
Operating Hours	TEC, 2007		
Maximum 100% H <sub>2</sub> SO <sub>4</sub> Acid Production	TEC, 2007		
Emission Factors ( SO <sub>2</sub> and H <sub>2</sub> SO <sub>4</sub> Mist)	TEC, 2007		
<b>NOTES AND OBSERVATIONS</b>			
<b>DATA CONTROL</b>			
Prepared by:	T. Davis, ECT	Date:	July 2007
Reviewed by:	D. Lukcic, TEC	Date:	July 2007

**Table A-11. Polk Power Station Unit 6 IGCC  
Sulfuric Acid Plant Startup/Shutdown Emission Rates**

**A. Sulfuric Acid Plant Decomposition Furnace Preheat Burner Data**

Natural Gas Usage (Per Event)	2.80	10 <sup>9</sup> ft <sup>3</sup>
	2,856	10 <sup>9</sup> Btu
Annual Preheat Events (Year 1)	3	events/yr

**B. Sulfuric Acid Plant Converter Preheat Burner Data**

Natural Gas Usage (Per Event)	2.42	10 <sup>9</sup> ft <sup>3</sup>
	2,468	10 <sup>9</sup> Btu
Annual Preheat Events (Year 1)	3	events/yr

**C. Sulfuric Acid Plant Preheat Burner Emissions (Year 1)**

Pollutant	Emission Factors (lb/10 <sup>9</sup> Btu) <sup>1</sup>	Sulfuric Acid Plant Preheat Burner Emissions				Totals	
		Decomposition Furnace		Converter		(lb/event)	(tpy)
		(lb/event)	(tpy)	(lb/event)	(tpy)		
PM <sub>10</sub>	0.0075	21.28	0.03	18.39	0.03	39.67	0.06
CO	0.0824	235.20	0.35	203.28	0.30	438.48	0.66
SO <sub>2</sub> <sup>2</sup>	0.0059	16.80	0.03	14.52	0.02	31.32	0.05
NO <sub>x</sub>	0.0980	280.00	0.42	242.00	0.36	522.00	0.78
VOC	0.0054	15.40	0.02	13.31	0.02	28.71	0.04

**D. Sulfuric Acid Plant Startup/Shutdown Emissions (Year 1)**

Annual Startup/Shutdown Events (Year 1) 3 events/yr

Pollutant	Sulfuric Acid Plant Startup/Shutdown Emissions (tpy)				Totals	
	Startup		Shutdown		(lb/event)	(tpy)
	(lb/event)	(tpy)	(lb/event)	(tpy)		
SO <sub>2</sub>	833.00	1.25	8.30	0.01	841.30	1.26
H <sub>2</sub> SO <sub>4</sub> Mist	83.00	0.12	0.83	0.00	83.83	0.13

**E. Total Sulfuric Acid Plant Startup/Shutdown Emissions (Year 1)**

Pollutant	Sulfuric Acid Plant Startup/Shutdown Emissions (tpy)			Totals
	Decomposition Furnace Preheat	Converter Preheat	Sulfuric Acid Plant	
PM <sub>10</sub>	0.03	0.03	N/A	0.06
CO	0.35	0.30	N/A	0.66
SO <sub>2</sub>	0.03	0.02	1.26	1.31
NO <sub>x</sub>	0.42	0.36	N/A	0.78
VOC	0.02	0.02	N/A	0.04
H <sub>2</sub> SO <sub>4</sub> Mist	Neg.	Neg.	0.13	0.13

<sup>1</sup> Section 1.4 (Natural Gas Combustion), AP-42, July 1998.

<sup>2</sup> SO<sub>2</sub> emission factor based on FDEP recommended natural gas sulfur content of 2.0 grains S / 100 ft<sup>3</sup>.

Sources: ECT, 2007.  
GE, 2007.

<b>POTENTIAL EMISSION INVENTORY WORKSHEET</b>				<b>A-12</b>	
Polk Power Station - Unit 6 IGCC				<b>Aux. Boiler</b>	
<b>EMISSION SOURCE TYPE</b>					
NATURAL GAS-FIRED EXTERNAL COMBUSTION SOURCES - CRITERIA POLLUTANTS AND CO					
<b>FACILITY AND SOURCE DESCRIPTION</b>					
Emission Source Description:		Natural Gas-Fired Auxiliary Steam Boiler			
Emission Control Method(s)/ID No.(s):		Low NO <sub>x</sub> Burners			
Emission Point Description:		6.21			
<b>EMISSION ESTIMATION EQUATIONS</b>					
Emission Rate (lb/hr) = Emission Factor (lb/MMBtu) x Rated Capacity (MMBtu/hr)					
Emission Rate (ton/yr) = Emission Factor (lb/hr) x Operating Period (hrs/yr) x (1 ton/ 2,000 lb)					
<b>INPUT DATA AND EMISSIONS CALCULATIONS</b>					
Maximum Operating Hours		876 hrs/yr			
Maximum Heat Input:		300.0 MMBtu/hr (HHV)			
Natural Gas Heat Content:		1,020 Btu/ft <sup>3</sup> (HHV)			
Fuel Consumption:		0.294 MM ft <sup>3</sup> /hr			
		257.6 MM ft <sup>3</sup> /yr			
No. of Boilers:		1			
Criteria Pollutant	Emission Factors		Potential Emission Rates		
	(lb/MM ft <sup>3</sup> )	(lb/MMBtu)	(lb/hr)	(tpy)	
NO <sub>x</sub>	37	0.036	10.8	4.7	
CO	37	0.036	10.8	4.7	
VOC	11.0	0.011	3.2	1.4	
SO <sub>2</sub>	6.0	0.0059	1.8	0.77	
PM/PM <sub>10</sub>	7.6	0.007	2.2	1.0	
Pb	5.00E-04	4.90E-07	1.47E-04	6.44E-05	
Non-Criteria Pollutant					
CO <sub>2</sub>	120,000	117.6	35,294	15,459	
<b>SOURCES OF INPUT DATA</b>					
Parameter		Data Source			
Operating Hours		TEC, 2007			
Maximum Heat Input (MMBtu/hr, HHV)		Bechtel, 2007.			
Emission Factors ( NO <sub>x</sub> and CO)		BACT			
Emission Factors ( PM/PM <sub>10</sub> , SO <sub>2</sub> , VOC, Pb, and CO <sub>2</sub> )		Section 1.3, Table 1.4-2, AP-42, July 1998.			
<b>NOTES AND OBSERVATIONS</b>					
SO <sub>2</sub> emission factor based on FDEP recommended natural gas sulfur content of 2.0 grains S / 100 ft <sup>3</sup> .					
<b>DATA CONTROL</b>					
Prepared by:		T. Davis, ECT		Date: July 2007	
Reviewed by:		D. Lukcic, TEC		Date: July 2007	

**POTENTIAL EMISSION INVENTORY WORKSHEET**

**A-13**

Polk Power Station - Unit 6 IGCC

**Aux. Boiler**

**EMISSION SOURCE TYPE**

NATURAL GAS FIRED EXTERNAL COMBUSTION SOURCES - HAZARDOUS AIR POLLUTANTS

**FACILITY AND SOURCE DESCRIPTION**

Emission Source Description: Natural Gas-Fired Auxiliary Steam Boiler  
 Emission Control Method(s)/ID No.(s): Low NO<sub>x</sub> Burners  
 Emission Point Description: 6.21

**EMISSION ESTIMATION EQUATIONS**

Emission Rate (lb/hr) = Emission Factor (lb/MMBtu) x Rated Capacity (MMBtu/hr)  
 Emission Rate (ton/yr) = Emission Rate (lb/hr) x Operating Period (hrs/yr) x (1 ton/ 2,000 lb)

**INPUT DATA AND EMISSIONS CALCULATIONS**

Maximum Operating Hours: 876 hrs/yr  
 Maximum Heat Input: 300.0 MMBtu/hr (HHV)  
 Natural Gas Heat Content: 1,020 Btu/ft<sup>3</sup> (HHV)  
 Fuel Consumption: 0.294 MM ft<sup>3</sup>/hr  
 257.6 MM ft<sup>3</sup>/yr  
 No. of Boilers: 1

Hazardous Air Pollutant	Emission Factors		Potential Emission Rates	
	(lb/MM ft <sup>3</sup> )	(lb/MMBtu)	(lb/hr)	(tpy)
<b>Organics</b>				
Acenaphthene	1.80E-06	1.76E-09	5.29E-07	2.32E-07
Acenaphthylene	1.80E-06	1.76E-09	5.29E-07	2.32E-07
Anthracene	2.40E-06	2.35E-09	7.06E-07	3.09E-07
Benz(a)anthracene	1.80E-06	1.76E-09	5.29E-07	2.32E-07
Benzene	2.10E-03	2.06E-06	6.18E-04	2.71E-04
Benzo(a)pyrene	1.20E-06	1.18E-09	3.53E-07	1.55E-07
Benzo(b,k)fluoranthene	1.80E-06	1.76E-09	5.29E-07	2.32E-07
Benzo(g,h,i)perylene	1.32E-06	1.29E-09	3.88E-07	1.70E-07
Benzo(k)fluoranthene	1.80E-06	1.76E-09	5.29E-07	2.32E-07
Chrysene	1.80E-06	1.76E-09	5.29E-07	2.32E-07
Dibenzo(a,h) anthracene	1.20E-06	1.18E-09	3.53E-07	1.55E-07
Dichlorobenzene	1.20E-03	1.18E-06	3.53E-04	1.55E-04
Fluoranthene	3.00E-06	2.94E-09	8.82E-07	3.86E-07
Fluorene	2.80E-06	2.75E-09	8.24E-07	3.61E-07
Formaldehyde	7.50E-02	7.35E-05	2.21E-02	9.66E-03
Hexane	3.31E-02	3.25E-05	9.74E-03	4.26E-03
Indo(1,2,3-cd)pyrene	1.80E-06	1.76E-09	5.29E-07	2.32E-07
Naphthalene	6.10E-04	5.98E-07	1.79E-04	7.86E-05
Phenanthrene	1.70E-05	1.67E-08	5.00E-06	2.19E-06
Pyrene	5.00E-06	4.90E-09	1.47E-06	6.44E-07
Toluene	3.40E-03	3.33E-06	1.00E-03	4.38E-04
<b>Metals</b>				
Arsenic	2.00E-04	1.96E-07	5.88E-05	2.58E-05
Beryllium	1.20E-05	1.18E-08	3.53E-06	1.55E-06
Cadmium	1.10E-03	1.08E-06	3.24E-04	1.42E-04
Chromium	1.40E-03	1.37E-06	4.12E-04	1.80E-04
Lead	5.00E-04	4.90E-07	1.47E-04	6.44E-05
Manganese	3.80E-04	3.73E-07	1.12E-04	4.90E-05
Mercury	2.60E-04	2.55E-07	7.65E-05	3.35E-05
Nickel	2.10E-03	2.06E-06	6.18E-04	2.71E-04
Selenium	2.40E-05	2.35E-08	7.06E-06	3.09E-06
<b>Totals</b>			<b>3.57E-02</b>	<b>1.56E-02</b>

Parameter	Data Source
Operating Hours	TEC, 2007
Maximum Heat Input (MMBtu/hr, HHV)	Bechtel, 2007.
Emission Factors (Organic Pollutants)	Section 1.4, Table 1.4-3, AP-42, July 1998.
Emission Factors (Metallic Pollutants)	Section 1.4, Table 1.4-4, AP-42, July 1998.

**NOTES AND OBSERVATIONS**

**DATA CONTROL**

Prepared by: T. Davis, ECT Date: July 2007  
 Reviewed by: D. Lukcic, TEC Date: July 2007

**Table A-14. Polk Power Station Unit 6 IGCC  
Gasifier Preheat Stack Emission Rates**

**A. Gasifier Preheat Burner Data (Per Gasifier)**

Natural Gas Usage (Per Event)	0.86	10 <sup>6</sup> ft <sup>3</sup>
	877	10 <sup>6</sup> Btu
Annual Preheat Events (Year 1)	21	events/yr

**B. Gasifier Preheat Stack Emissions (Year 1)**

Pollutant	Emission Factors (lb/10 <sup>6</sup> Btu) <sup>1</sup>	Gasifier Preheat Stack Emissions					
		Train 1		Train 2		Trains 1 & 2	
		(lb/event)	(tpy)	(lb/event)	(tpy)	(lb/event)	(tpy)
PM <sub>10</sub>	0.0075	6.5	0.07	6.5	0.07	13.1	0.14
CO	0.0824	72.2	0.8	72.2	0.8	144.5	1.5
SO <sub>2</sub> <sup>2</sup>	0.0059	5.2	0.054	5.2	0.054	10.3	0.108
NO <sub>x</sub>	0.0980	86.0	0.9	86.0	0.9	172.0	1.8
VOC	0.0054	4.7	0.050	4.7	0.050	9.5	0.099

<sup>1</sup> Section 1.4 (Natural Gas Combustion), AP-42, July 1998.

<sup>2</sup> SO<sub>2</sub> emission factor based on FDEP recommended natural gas sulfur content of 2.0 grains S / 100 ft<sup>3</sup>.

Sources: ECT, 2007.  
GE, 2007.

**Table A-15A. Polk Power Station Unit 6 IGCC  
Flare Emission Rates: Year 1**

**A. Flare Pilots**

Flare Pilots Natural Gas Heat Input	1.23	10 <sup>6</sup> Btu/hr
Annual Hours	8,760	hr/yr

Pollutant	Emissions		
	(lb/10 <sup>6</sup> Btu) <sup>1</sup>	(lb/hr)	(tpy)
PM <sub>10</sub>	0.0075	0.009	0.04
CO	0.0824	0.101	0.44
SO <sub>2</sub> <sup>2</sup>	0.0059	0.007	0.03
NO <sub>x</sub>	0.0980	0.121	0.53
VOC	0.0054	0.007	0.03

**B. Gasifier Startups (Year 1)**

Annual Startup Events (Per Train)	26	events/yr
-----------------------------------	----	-----------

Pollutant	Flare Emissions -Gasifier Startups					
	Train 1		Train 2		Trains 1 & 2	
	(lb/event)	(tpy)	(lb/event)	(tpy)	(lb/event)	(tpy)
PM <sub>10</sub>	0.41	0.0053	0.41	0.0053	0.82	0.0107
CO	479.0	6.2	419.0	5.4	898.0	11.7
SO <sub>2</sub>	653.0	8.5	634.0	8.2	1,287.0	16.7
NO <sub>x</sub>	93.0	1.2	82.0	1.1	175.0	2.3
VOC	0.30	0.0039	0.30	0.0039	0.6	0.008

**C. Gasifier Shutdowns (Year 1)**

Annual Shutdown Events (Per Train)	26	events/yr
------------------------------------	----	-----------

Pollutant	Flare Emissions - Gasifier Shutdowns					
	Train 1		Train 2		Trains 1 & 2	
	(lb/event)	(tpy)	(lb/event)	(tpy)	(lb/event)	(tpy)
PM <sub>10</sub>	0.85	0.0111	0.85	0.0111	1.7	0.0221
CO	147.5	1.9	147.5	1.9	295.0	3.8
SO <sub>2</sub>	1,325.0	17.2	1,325.0	17.2	2,650.0	34.5
NO <sub>x</sub>	36.5	0.5	36.5	0.5	73.0	0.9
VOC	0.60	0.0078	0.60	0.0078	1.2	0.016

**D. Total Flare Emissions (Year 1)**

Pollutant	Flare Emissions (tpy)			
	Pilots	Startups	Shutdowns	Totals
PM <sub>10</sub>	0.04	0.01	0.02	0.07
CO	0.44	11.67	3.84	15.95
SO <sub>2</sub>	0.03	16.73	34.45	51.21
NO <sub>x</sub>	0.53	2.28	0.95	3.75
VOC	0.03	0.01	0.02	0.05

<sup>1</sup> Section 1.4 (Natural Gas Combustion), AP-42, July 1998.

<sup>2</sup> SO<sub>2</sub> emission factor based on FDEP recommended natural gas sulfur content of 2.0 grains S / 100 ft<sup>3</sup>.

Sources: ECT, 2007.  
GE, 2007.

**Table A-15B. Polk Power Station Unit 6 IGCC  
Flare Emission Rates: Year 4+**

**A. Flare Pilots**

Flare Pilots Natural Gas Heat Input 1.23 10<sup>6</sup> Btu/hr

Annual Hours 8,760 hr/yr

Pollutant	Emissions		
	(lb/10 <sup>6</sup> Btu) <sup>1</sup>	(lb/hr)	(tpy)
PM <sub>10</sub>	0.0075	0.009	0.04
CO	0.0824	0.101	0.44
SO <sub>2</sub> <sup>2</sup>	0.0059	0.007	0.03
NO <sub>x</sub>	0.0980	0.121	0.53
VOC	0.0054	0.007	0.03

**B. Gasifier Startups (Year 4+)**

Annual Startup Events (Per Train) 16 events/yr

Pollutant	Flare Emissions -Gasifier Startups					
	Train 1		Train 2		Trains 1 & 2	
	(lb/event)	(tpy)	(lb/event)	(tpy)	(lb/event)	(tpy)
PM <sub>10</sub>	0.41	0.0033	0.41	0.0033	0.82	0.0066
CO	479.0	3.8	419.0	3.4	898.0	7.2
SO <sub>2</sub>	653.0	5.2	634.0	5.1	1,287.0	10.3
NO <sub>x</sub>	93.0	0.7	82.0	0.7	175.0	1.4
VOC	0.30	0.0024	0.30	0.0024	0.6	0.005

**C. Gasifier Shutdowns (Year 4+)**

Annual Shutdown Events (Per Train) 16 events/yr

Pollutant	Flare Emissions - Gasifier Shutdowns					
	Train 1		Train 2		Trains 1 & 2	
	(lb/event)	(tpy)	(lb/event)	(tpy)	(lb/event)	(tpy)
PM <sub>10</sub>	0.85	0.0068	0.85	0.0068	1.7	0.0136
CO	147.5	1.2	147.5	1.2	295.0	2.4
SO <sub>2</sub>	1,325.0	10.6	1,325.0	10.6	2,650.0	21.2
NO <sub>x</sub>	36.5	0.3	36.5	0.3	73.0	0.6
VOC	0.60	0.0048	0.60	0.0048	1.2	0.010

**D. Total Flare Emissions (Year 4+)**

Pollutant	Flare Emissions (tpy)			
	Pilots	Startups	Shutdowns	Totals
PM <sub>10</sub>	0.04	0.01	0.01	0.06
CO	0.44	7.18	2.36	9.99
SO <sub>2</sub>	0.03	10.30	21.20	31.53
NO <sub>x</sub>	0.53	1.40	0.58	2.51
VOC	0.03	0.00	0.01	0.04

<sup>1</sup> Section 1.4 (Natural Gas Combustion), AP-42, July 1998.

<sup>2</sup> SO<sub>2</sub> emission factor based on FDEP recommended natural gas sulfur content of 2.0 grains S / 100 ft<sup>3</sup>.

Sources: ECT, 2007.  
GE, 2007.

**POTENTIAL EMISSION INVENTORY WORKSHEET**

**A-16**

Polk Power Station - Unit 6 IGCC

**Firewater Diesels**

**EMISSION SOURCE TYPE**

EMERGENCY FIREWATER PUMP DIESEL ENGINE - CRITERIA POLLUTANTS AND CO<sub>2</sub>

**FACILITY AND SOURCE DESCRIPTION**

Emission Source Description: 420 HP Diesel Engine  
 Emission Control Method(s)/ID No.(s): Lean Burn  
 Emission Point Location: 6.19

**EMISSION ESTIMATION EQUATIONS**

Emission Rate (lb/hr) = Emission Factor (g/kW-hr) x Engine Output (kW)  
 Emission Rate (ton/yr) = Emission Factor (g/kW-hr) x Engine Output (kW) x Operating Period (hrs/yr) x (1 ton/ 2,000 lb)

**INPUT DATA AND EMISSIONS CALCULATIONS**

Operating Hours:	100	hrs/yr (for maintenance and testing, excluding emergency situations)
Number of Engines:	2	
Diesel Fuel Oil Sulfur Content:	0.0015	Weight % S
Diesel Fuel Oil Heat Content:	134,000	Btu/gal (HHV)
Engine Heat Rate:	7,000	Btu/HP-hr (nominal rate, assumed)
Heat Input:	2.94	MMBtu/hr
Diesel Fuel Consumption:	21.9	gal/hr
	2,194	gal/yr (for maintenance and testing, excluding emergency situations)
Engine Output	313	Kilowatts (kW)
Engine Output:	420	Horsepower (HP)

Criteria Pollutant	Emission Factors		Potential Emission Rates (Per Engine)		Potential Emission Rates (Two Engines)	
	(g/kW-hr)	(lb/HP-hr)	(lb/hr)	(tpy)	(lb/hr)	(tpy)
NO <sub>x</sub>	10.5	0.0173	7.2	0.36	14.5	0.72
CO	3.5	0.0058	2.4	0.12	4.8	0.24
VOC	1.5	0.0025	1.1	0.05	2.1	0.11
SO <sub>2</sub>	0.0074	0.000012	0.0051	0.00025	0.010	0.00051
PM	0.54	0.00089	0.37	0.0186	0.75	0.037
PM <sub>10</sub>	0.54	0.00089	0.37	0.0186	0.75	0.037
Non-Criteria Pollutant						
CO <sub>2</sub>	699.5	1.15	483.0	24.2	966.0	48.3

**SOURCES OF INPUT DATA**

Parameter	Data Source
Engine Output (HP)	Bechtel, 2007.
Diesel Fuel Sulfur Content	TEC, 2007.
Emission Factors (NO <sub>x</sub> , CO, and PM)	NSPS Subpart IIII, Table 4
Emission Factors (VOC and CO <sub>2</sub> )	Section 3.3, Table 3.3-1, AP-42, October 1996.
Emission Factor (SO <sub>2</sub> )	Section 3.4, Table 3.4-1, AP-42, October 1996.

**NOTES AND OBSERVATIONS**

PM and PM<sub>10</sub> emissions assumed to be equal.

**DATA CONTROL**

Prepared by:	T. Davis, ECT	Date:	July 2007
Reviewed by:	D. Lukcic, TEC	Date:	July 2007



**POTENTIAL EMISSION INVENTORY WORKSHEET**

**A-17**

Polk Power Station - Unit 6 IGCC

Firewater Diesels

**EMISSION SOURCE TYPE**

EMERGENCY FIREWATER PUMP DIESEL ENGINE - HAZARDOUS AIR POLLUTANTS

**FACILITY AND SOURCE DESCRIPTION**

Emission Source Description: 420 HP Diesel Engine  
 Emission Control Method(s)/ID No.(s): Lean Burn  
 Emission Point Location: 6.19

**EMISSION ESTIMATION EQUATIONS**

Emission Rate (lb/hr) = Emission Factor (lb/MMBtu) x Engine Heat Input (MMBtu/hr)  
 Emission Rate (ton/yr) = Emission Factor (lb/MMBtu) x Engine Heat Input (MMBtu/hr) x Operating Period (hrs/yr) x (1 ton/ 2,000 lb)

**INPUT DATA AND EMISSIONS CALCULATIONS**

Operating Hours:	100	hrs/yr (for maintenance and testing, excluding emergency situations)
Number of Engines:	2	
Diesel Fuel Oil Sulfur Content:	0.0015	Weight % S
Diesel Fuel Oil Heat Content:	134,000	Btu/gal (HHV)
Engine Heat Rate:	7,000	Btu/HP-hr (nominal rate, assumed)
Heat Input:	2.94	MMBtu/hr
Diesel Fuel Consumption:	21.9	gal/hr
	2,194	gal/yr (for maintenance and testing, excluding emergency situations)
Engine Output	313	Kilowatts (kW)
Engine Output:	420	Horsepower (HP)

Criteria Pollutant	Emission Factors		Potential Emission Rates (Per Engine)		Potential Emission Rates (Two Engines)	
	(lb/MMBtu)	(lb/HP-hr)	(lb/hr)	(tpy)	(lb/hr)	(tpy)
1,3-Butadiene	3.91E-05	2.74E-07	1.15E-04	5.75E-06	2.30E-04	1.15E-05
Acetaldehyde	7.67E-04	5.37E-06	2.25E-03	1.13E-04	4.51E-03	2.25E-04
Acrolein	9.25E-05	6.48E-07	2.72E-04	1.36E-05	5.44E-04	2.72E-05
Benzene	9.33E-04	6.53E-06	2.74E-03	1.37E-04	5.49E-03	2.74E-04
Formaldehyde	1.18E-03	8.26E-06	3.47E-03	1.73E-04	6.94E-03	3.47E-04
Polycyclic Aromatic Hydrocarbons (PAH)	1.68E-04	1.18E-06	4.94E-04	2.47E-05	9.88E-04	4.94E-05
Toluene	4.09E-04	2.86E-06	1.20E-03	6.01E-05	2.40E-03	1.20E-04
Xylene	2.85E-04	2.00E-06	8.38E-04	4.19E-05	1.68E-03	8.38E-05
<b>Total HAPs</b>			<b>1.14E-02</b>	<b>5.69E-04</b>	<b>2.28E-02</b>	<b>1.14E-03</b>

**SOURCES OF INPUT DATA**

Parameter	Data Source
Engine Output (HP)	Bechtel, 2007.
Diesel Fuel Sulfur Content	TEC, 2007.
Emission Factors (All)	Section 3.3, Table 3.3-2, AP-42, October 1996.

**NOTES AND OBSERVATIONS**

PM and PM<sub>10</sub> emissions assumed to be equal.

**DATA CONTROL**

Prepared by:	T. Davis, ECT	Date:	July 2007
Reviewed by:	D. Lukcic, TEC	Date:	July 2007

**POTENTIAL EMISSION INVENTORY WORKSHEET**

**A-18**

Polk Power Station - Unit 6 IGCC

Generator Diesel

**EMISSION SOURCE TYPE**

EMERGENCY GENERATOR DIESEL ENGINE - CRITERIA POLLUTANTS AND CO<sub>2</sub>

**FACILITY AND SOURCE DESCRIPTION**

Emission Source Description: 2,200 HP Diesel Engine  
 Emission Control Method(s)/ID No.(s): Lean Burn  
 Emission Point Location: 6.20

**EMISSION ESTIMATION EQUATIONS**

Emission Rate (lb/hr) = Emission Factor (g/kW-hr) x Engine Output (kW)  
 Emission Rate (ton/yr) = Emission Factor (g/kW-hr) x Engine Output (kW) x Operating Period (hrs/yr) x (1 ton/ 2,000 lb)

**INPUT DATA AND EMISSIONS CALCULATIONS**

Operating Hours:	100	hrs/yr (for maintenance and testing, excluding emergency situations)
Number of Engines:	1	
Diesel Fuel Oil Sulfur Content:	0.0015	Weight % S
Diesel Fuel Oil Heat Content:	134,000	Btu/gal (HHV)
Engine Heat Rate:	7,000	Btu/HP-hr (nominal rate, assumed)
Heat Input:	15.40	MMBtu/hr
Diesel Fuel Consumption:	114.9	gal/hr
	11,493	gal/yr (for maintenance and testing, excluding emergency situations)
Engine Output	1,641	Kilowatts (kW)
Engine Output:	2,200	Horsepower (HP)

Criteria Pollutant	Emission Factors		Potential Emission Rates	
	(g/kW-hr)	(lb/HP-hr)	(lb/hr)	(tpy)
NO <sub>x</sub>	6.4	0.0105	23.1	1.2
CO	3.5	0.0058	12.7	0.63
VOC	0.4	0.00071	1.6	0.078
SO <sub>2</sub>	0.0074	0.000012	0.0267	0.0013
PM	0.2	0.00033	0.72	0.036
PM <sub>10</sub>	0.2	0.00033	0.72	0.036
Non-Criteria Pollutant				
CO <sub>2</sub>	705.6	1.16	2,552	127.6

**SOURCES OF INPUT DATA**

Parameter	Data Source
Engine Output (HP)	Bechtel Power Corporation, April 2007.
Diesel Fuel Sulfur Content	TEC, April, 2007.
Emission Factors (NO <sub>x</sub> , CO, and PM)	NSPS Subpart IIII, 40 CFR 89.112, Tier 2
Emission Factors (SO <sub>2</sub> , VOC and CO <sub>2</sub> )	Section 3.4, Table 3.4-1, AP-42, October 1996.

**NOTES AND OBSERVATIONS**

PM and PM<sub>10</sub> emissions assumed to be equal.

**DATA CONTROL**

Prepared by:	T. Davis, ECT	Date:	July 2007
Reviewed by:	D. Lukcic, TEC	Date:	July 2007

**POTENTIAL EMISSION INVENTORY WORKSHEET**

**A-19**  
Generator Diesel

Polk Power Station - Unit 6 IGCC

**EMISSION SOURCE TYPE**

EMERGENCY GENERATOR DIESEL ENGINE - HAZARDOUS AIR POLLUTANTS

**FACILITY AND SOURCE DESCRIPTION**

Emission Source Description: 2,200 HP Diesel Engine  
 Emission Control Method(s)/ID No.(s): Lean Burn  
 Emission Point Location: 6.20

**EMISSION ESTIMATION EQUATIONS**

Emission Rate (lb/hr) = Emission Factor (lb/MMBtu) x Engine Heat Input (MMBtu/hr)  
 Emission Rate (ton/yr) = Emission Factor (lb/MMBtu) x Engine Heat Input (MMBtu/hr) x Operating Period (hrs/yr) x (1 ton/ 2,000 lb)

**INPUT DATA AND EMISSIONS CALCULATIONS**

Operating Hours:	100	hrs/yr (for maintenance and testing, excluding emergency situations)
Number of Engines:	1	
Diesel Fuel Oil Sulfur Content:	0.0015	Weight % S
Diesel Fuel Oil Heat Content:	134,000	Btu/gal (HHV)
Engine Heat Rate:	7,000	Btu/HP-hr (nominal rate, assumed)
Heat Input:	15.40	MMBtu/hr
Diesel Fuel Consumption:	114.9	gal/hr
	11,493	gal/yr (for maintenance and testing, excluding emergency situations)
Engine Output	1,641	Kilowatts (kW)
Engine Output:	2,200	Horsepower (HP)

Criteria Pollutant	Emission Factors		Potential Emission Rates (Per Engine)	
	(lb/MMBtu)	(lb/HP-hr)	(lb/hr)	(tpy)
Acetaldehyde	2.25E-05	1.58E-07	3.47E-04	1.73E-05
Acrolein	7.88E-06	5.52E-08	1.21E-04	6.07E-06
Benzene	7.76E-04	5.43E-06	1.20E-02	5.98E-04
Formaldehyde	7.89E-05	5.52E-07	1.22E-03	6.08E-05
Polycyclic Aromatic Hydrocarbons (PAH)	2.12E-04	1.48E-06	3.26E-03	1.63E-04
Toluene	2.81E-04	1.97E-06	4.33E-03	2.16E-04
Xylene	1.93E-04	1.35E-06	2.97E-03	1.49E-04
<b>Total HAPs</b>			<b>2.42E-02</b>	<b>1.21E-03</b>

**SOURCES OF INPUT DATA**

Parameter	Data Source
Engine Output (HP)	Bechtel, 2007.
Diesel Fuel Sulfur Content	TEC, April, 2007.
Emission Factors (All except PAH)	Section 3.4, Table 3.4-3, AP-42, October 1996.
Emission Factors (PAH)	Section 3.4, Table 3.4-4, AP-42, October 1996.

**NOTES AND OBSERVATIONS**

**DATA CONTROL**

Prepared by:	T. Davis, ECT	Date:	July 2007
Reviewed by:	D. Lukcic, TEC	Date:	July 2007

# POTENTIAL EMISSION INVENTORY WORKSHEET

**Table A-20**  
**Cooling Tower**

Polk Power Station - Unit 6 IGCC

## EMISSION SOURCE TYPE

COOLING TOWERS - PM/PM<sub>10</sub>

## FACILITY AND SOURCE DESCRIPTION

Emission Source Description: Mechanical Draft Cooling Tower

Emission Control Method(s)/ID No.(s): Mist Eliminators

Emission Point Description: 6.5

## EMISSION ESTIMATION EQUATIONS

PM Emission Rate (lb/hr) = Recirculating Water Flow Rate (gpm) x (Drift Loss Rate (%) / 100) x 8.345 lb/gal x (TDS (ppmw) / 100) x 60 min/hr

PM Emission Rate (ton/yr) = PM Emission (lb/hr) x Operating Period (hrs/yr) x (1 ton/ 2,000 lb)

PM<sub>10</sub> Emission Rate (lb/hr) = PM Emissions (lb/hr) x PM<sub>10</sub>/PM Fraction

PM<sub>10</sub> Emission Rate (ton/yr) = PM<sub>10</sub> Emission (lb/hr) x Operating Period (hrs/yr) x (1 ton/ 2,000 lb)

Source: ECT, 2007.

## INPUT DATA AND EMISSIONS CALCULATIONS

### Cooling Tower Data

Operating Hours:	8,760	hrs/yr		
Number of Cells:	10			
Recirculating Water Flow Rate:	145,000	gal/min		
Drift Loss Rate:	0.0005	%		
Total Dissolved Solids (TDS):	16,250	ppmw		
PM <sub>10</sub> /PM Fraction:	0.023			
Number of Towers:	1			
Pollutant	Potential Emission Rates (Per Cell)		Potential Emission Rates (Total)	
	(lb/hr)	(tpy)	(lb/hr)	(tpy)
PM	0.59	2.6	5.9	25.8
PM <sub>10</sub>	0.014	0.06	0.14	0.6

## SOURCES OF INPUT DATA

Parameter	Data Source
Operating Hours (annual)	TEC, 2007.
Recirculating Water Flow Rate (gpm)	Bechtel, 2007.
Drift Loss Rate (%)	Bechtel, 2007.
Total Dissolved Solids (ppmw)	Bechtel, 2007.
PM <sub>10</sub> /PM Fraction:	ECT, 2007.

## NOTES AND OBSERVATIONS

## DATA CONTROL

Prepared by: T. Davis, ECT July 2007  
Reviewed by: D. Lukcic, TEC July 2007

**Table A-21. Polk Power Station Unit 6 IGCC  
Cooling Tower PM/PM<sub>10</sub> Fractions**

**Procedure Citation:**

AWMA Abstract No. 216, Session No. AM-1b, Orlando, 2001.  
*Calculating Realistic PM<sub>10</sub> Emissions from Cooling Towers*

**Cooling Tower Design Data:**

Cooling Tower Recirculating Water Total Dissolved Solids: 16,250 ppmw  
Cooling Tower PM<sub>10</sub> Density (assumed NaCl): 2.2 g/cm<sup>3</sup>

**Particle Size Distribution:**

Droplet Diameter (μm)	Droplet Volume (m <sup>3</sup> )	Droplet Mass (g)	Particle Mass (g)	Particle Volume (m <sup>3</sup> )	Particle Diameter (μm)	Mass Fraction (%)
10	5.24E-16	5.24E-10	8.51E-12	3.87E-18	1.947	0.000
20	4.19E-15	4.19E-09	6.81E-11	3.09E-17	3.895	0.196
30	1.41E-14	1.41E-08	2.30E-10	1.04E-16	5.842	0.226
40	3.35E-14	3.35E-08	5.45E-10	2.48E-16	7.790	0.514
50	6.54E-14	6.54E-08	1.06E-09	4.83E-16	9.737	1.816
60	1.13E-13	1.13E-07	1.84E-09	8.35E-16	11.685	5.702
70	1.80E-13	1.80E-07	2.92E-09	1.33E-15	13.632	21.348
90	3.82E-13	3.82E-07	6.20E-09	2.82E-15	17.527	49.812
110	6.97E-13	6.97E-07	1.13E-08	5.15E-15	21.422	70.509
130	1.15E-12	1.15E-06	1.87E-08	8.50E-15	25.317	82.023
150	1.77E-12	1.77E-06	2.87E-08	1.31E-14	29.212	88.012
180	3.05E-12	3.05E-06	4.96E-08	2.26E-14	35.055	91.032
210	4.85E-12	4.85E-06	7.88E-08	3.58E-14	40.897	92.468
240	7.24E-12	7.24E-06	1.18E-07	5.35E-14	46.740	94.091
270	1.03E-11	1.03E-05	1.67E-07	7.61E-14	52.582	94.689
300	1.41E-11	1.41E-05	2.30E-07	1.04E-13	58.425	96.288
350	2.24E-11	2.24E-05	3.65E-07	1.66E-13	68.162	97.011
400	3.35E-11	3.35E-05	5.45E-07	2.48E-13	77.900	98.340
450	4.77E-11	4.77E-05	7.75E-07	3.52E-13	87.637	99.071
500	6.54E-11	6.54E-05	1.06E-06	4.83E-13	97.375	99.071
600	1.13E-10	1.13E-04	1.84E-06	8.35E-13	116.850	100.000

**Linear Interpolation:**

Droplet Diameter (μm)	Droplet Volume (m <sup>3</sup> )	Droplet Mass (g)	Particle Mass (g)	Particle Volume (m <sup>3</sup> )	Particle Diameter (μm)	Mass Fraction (%)
50	6.54E-14	6.54E-08	1.06E-09	4.83E-16	9.737	1.816
60	1.13E-13	1.13E-07	1.84E-09	8.35E-16	11.685	5.702
					<b>10.000</b>	<b>2.340</b>

Mass Fraction of Cooling Tower PM ≤ PM <sub>10</sub> :	0.023
--	-------

Sources: ECT, 2007  
Bechtel, 2007

# POTENTIAL EMISSION INVENTORY WORKSHEET

Table A-22

Polk Power Station - Unit 6 IGCC

## EMISSION SOURCE TYPE

### FUGITIVE PM/PM<sub>10</sub> - OUTDOOR STORAGE PILES

#### FACILITY AND SOURCE DESCRIPTION

Emission Source Description: Fugitive PM - Outdoor Storage Piles (Gasifier Feedstocks and Slag)  
 Emission Control Method(s)/ID No.(s): Moist materials, watering and use of surfactants, as necessary, application of crusting agents.  
 Emission Point ID: 6.6 (Active Feedstock), 6.109 (Inactive Feedstock - North), 6.7 (Inactive Feedstock - South), 6.8 (Emergency Feedstock), 6.9 (Slag)

#### EMISSION ESTIMATION EQUATIONS

PM/PM<sub>10</sub> Emission (lb/hr) = Emission Factor (lb PM/PM<sub>10</sub>/acre/day) x Storage Pile Area (acres) x (1 day/24 hrs)  
 PM/PM<sub>10</sub> Emission (ton/yr) = Emission Factor (lb PM/PM<sub>10</sub>/acre/day) x Storage Pile Area (acres) x Storage Period (dys/yr) x (1 ton/2,000 lb)

Source: ECT, 2007.

#### INPUT DATA AND EMISSIONS CALCULATIONS

Storage Pile Material Type	Source ID	Period of Storage (dys/yr)	Pile Area (acre)	Uncontrolled Emission Factor (lb PM/acre/dy)	Control Efficiency (%)	Controlled Emission Factor (lb PM/acre/dy)	Potential PM Emission Rates		
							(lb/hr)	(tpy)	
Active Feedstock Pile	6.6	365	1.406	13.2	85.0	1.98	0.116	0.508	
Emergency Feedstock Stack-Out	6.8	365	0.721	13.2	85.0	1.98	0.059	0.261	
Inactive Feedstock Pile - North	6.109	365	8.884	3.5	95.0	0.18	0.065	0.284	
Inactive Feedstock Pile - South	6.7	365	10.285	3.5	95.0	0.18	0.075	0.328	
Slag Storage	6.9	365	0.413	13.2	85.0	1.98	0.034	0.149	
<b>Totals</b>								<b>0.349</b>	<b>1.530</b>

Storage Pile Material Type	Source ID	Period of Storage (dys/yr)	Pile Area (acre)	Uncontrolled Emission Factor (lb PM <sub>10</sub> /acre/dy)	Control Efficiency (%)	Controlled Emission Factor (lb PM <sub>10</sub> /acre/dy)	Potential PM <sub>10</sub> Emission Rates		
							(lb/hr)	(tpy)	
Active Feedstock Pile	6.6	365	1.406	6.3	85.0	0.95	0.055	0.242	
Emergency Feedstock Stack-Out	6.8	365	0.721	6.3	85.0	0.95	0.028	0.124	
Inactive Feedstock Pile - North	6.109	365	8.884	1.7	95.0	0.09	0.031	0.138	
Inactive Feedstock Pile - South	6.7	365	10.285	1.7	95.0	0.09	0.036	0.160	
Slag Storage	6.9	365	0.413	6.3	85.0	0.95	0.016	0.071	
<b>Totals</b>								<b>0.168</b>	<b>0.736</b>

#### SOURCES OF INPUT DATA

Parameter	Data Source
Uncontrolled Emission Factors	Section 8.19.1-1, AP-42, September 1991.
Control Efficiency - Active Pile	Watering and use of surfactants, as necessary. <i>Fugitive Emissions from Coal-Fired Power Plants</i> , EPRI, June 1984.
Control Efficiency - Inactive Piles	Application of crusting agents.
Pile Size (acre)	Bechtel, 2007.

#### NOTES AND OBSERVATIONS

#### DATA CONTROL

**Prepared by:** T. Davis, ECT **Date:** July 2007  
**Reviewed by:** D. Lukcic, TEC **Date:** July 2007

**Table A-23. Polk Power Station Unit 6 IGCC  
Material Handling Point Source PM/PM<sub>10</sub> Emission Rates**

Emission Source	Source ID	Baghouse Flow Rate (scf/min)	PM/PM <sub>10</sub> Emissions		
			(gr/scf)	(lb/hr)	(tpy)
Feedstock Blending	6.10	2,500	0.010	0.21	0.9
Feedstock Grinding	6.11	2,500	0.010	0.21	0.9
<b>Totals</b>		<b>5,000</b>	<b>N/A</b>	<b>0.43</b>	<b>1.9</b>

Sources: Bechtel, 2007.  
ECT, 2007.

**Table A-24. Polk Power Station Unit 6 IGCC  
Material Handling Fugitive Source PM<sub>10</sub> Emission Rates**

Area/Source Description	Max. Capacity (ton/hr)	Average Throughput (ton/yr)	Annual Operations (hrs/yr)	PM <sub>10</sub> Emission Factor		Emission Control(s)	Control Efficiency (%)	Potential PM <sub>10</sub> Emissions	
				Value	Units			(lb/hr)	(tpy)
<b>Rail Unloading Station Enclosure</b>									
Railcar to unloading bins	3,000	3,011,250	1,004	1.02E-04	lb/ton	WS	85	0.046	0.023
Unloading bins to 01-MH-002	3,000	3,011,250	1,004	1.02E-04	lb/ton	Residual	75	0.076	0.038
							<b>Totals</b>	<b>0.122</b>	<b>0.061</b>
<b>Transfer Tower (01-AK-002) to Coal/Coke Storage Structure</b>									
01-MH-002 to 01-MH-004	3,000	2,162,625	721	1.02E-04	lb/ton	WS	85	0.046	0.017
01-MH-002 to 01-MH-007	3,000	2,162,625	721	1.02E-04	lb/ton	WS	85	0.046	0.017
01-MH-005 to 01-MH-006	500	848,625	1,697	1.02E-04	lb/ton	Residual	75	0.013	0.011
							<b>Totals</b>	<b>0.104</b>	<b>0.044</b>
<b>Coal/Coke Storage Structure</b>									
Tripper MY-003 to coal/coke piles	3,000	2,162,625	721	1.02E-04	lb/ton	WS	85	0.046	0.017
Tripper MY-006 to coal/coke piles	500	848,625	1,697	1.02E-04	lb/ton	WS	85	0.008	0.006
Reclaimers MY-007A to 01-MH-008A/B	500	1,505,625	3,011	1.02E-04	lb/ton	Residual	75	0.013	0.019
Reclaimers MY-007B to 01-MH-008A/B	500	1,505,625	3,011	1.02E-04	lb/ton	Residual	75	0.013	0.019
01-MH-008A to 01-MH-009A/B	500	1,505,625	3,011	1.02E-04	lb/ton	Residual	75	0.013	0.019
01-MH-008B to 01-MH-009A/B	500	1,505,625	3,011	1.02E-04	lb/ton	Residual	75	0.013	0.019
							<b>Totals</b>	<b>0.104</b>	<b>0.100</b>
<b>Emergency Storage Pile</b>									
01-MH-007 to stacking tubc	3,000	3,011,250	1,004	4.00E-04	lb/ton	WS	85	0.180	0.090
Grading	1,000	3,011,250	3,011	1.22E-01	lb/VMT	WS	85	0.037	0.055
Dozer to reclaim bins	500	3,011,250	6,023	1.22E-01	lb/VMT	Residual	75	0.061	0.184
Reclaim bins to 01-MH-011	500	3,011,250	6,023	1.02E-04	lb/ton	Residual	75	0.013	0.038
01-MH-0011 to 01-MH-009A/B	500	3,011,250	6,023	1.02E-04	lb/ton	Residual	75	0.013	0.038
							<b>Totals</b>	<b>0.303</b>	<b>0.406</b>
<b>Transfer Tower (01-AK-004) to Coal/Coke Silos</b>									
01-MH-009A to 01-MH-013A	500	1,505,625	3,011	1.02E-04	lb/ton	Residual	75	0.013	0.019
01-MH-009B to 01-MH-013B	500	1,505,625	3,011	1.02E-04	lb/ton	Residual	75	0.013	0.019
							<b>Totals</b>	<b>0.025</b>	<b>0.038</b>
<b>Blending Area - Fuel Silos &amp; Fluxant Storage Bin</b>									
Coal/Coke to belt weigh feeders	1,000	3,011,250	3,011	1.02E-04	lb/ton	WS	85	0.015	0.023
Flux to belt weigh feeders	500	451,688	903	1.02E-04	lb/ton	WS	85	0.008	0.003
Belt weigh feeders to 01MH-024A/B	1,000	3,462,938	3,463	1.02E-04	lb/ton	WS	85	0.015	0.026
01MH-024A/B to Unit 6 via MH-026A/B	1,000	2,487,019	2,487	1.02E-04	lb/ton	WS	85	0.015	0.019
01MH-024A/B to Unit 1 via MH-025A/B	1,000	975,919	976	1.02E-04	lb/ton	WS	85	0.015	0.007
							<b>Totals</b>	<b>0.069</b>	<b>0.079</b>
<b>Transfer Tower (01-AK-005) to Blended Fuel Hoppers</b>									
01-MH-026A/B to MH-027A/B	1,000	2,487,019	2,487	1.02E-04	lb/ton	Residual	75	0.025	0.032
01-MH-029 to MH-027A/B	500	500,000	1,000	1.02E-04	lb/ton	Residual	75	0.013	0.006
							<b>Totals</b>	<b>0.038</b>	<b>0.038</b>
<b>Grinding Structure (blended fuel for Unit 1)</b>									
Fuel Storage Hoppers to weigh feeders	500	2,487,019	4,974	1.02E-04	lb/ton	Residual	75	0.013	0.032
							<b>Totals</b>	<b>0.013</b>	<b>0.032</b>
<b>Inactive Coal Pile</b>									
01-MH-008A to conveyor	500	3,011,250	6,023	1.02E-04	lb/ton	Residual	75	0.013	0.038
Conveyor to conveyor	500	3,011,250	6,023	1.02E-04	lb/ton	Residual	75	0.013	0.038
Conveyor to inactive coal pile area	500	3,011,250	6,023	1.02E-04	lb/ton	Residual	75	0.013	0.038
Grading	1,000	3,011,250	3,011	1.22E-01	lb/VMT	WS	85	0.037	0.055
Dozing to dozer trap	500	3,011,250	6,023	1.22E-01	lb/VMT	Residual	75	0.061	0.184
Conveyor to conveyor	500	3,011,250	6,023	1.02E-04	lb/ton	Residual	75	0.013	0.038
Conveyor to transfer tower AK-002	500	3,011,250	6,023	1.02E-04	lb/ton	Residual	75	0.013	0.038
							<b>Totals</b>	<b>0.161</b>	<b>0.430</b>
								<b>0.941</b>	<b>1.228</b>

Notes:

Total Units 1 & 6 coal/pe coke: 3,011,250 Emission factors (EFs) for grading operations based on AP-42: Section 11.9 Western Surface Coal Mining dated October 1998.  
 Fluxant (max at 15% of coal/coke) 451,688 PM<sub>10</sub> = 0.60 x 0.051 x S<sup>2.0</sup> = 0.122 lb/VMT (VMT is vehicle miles traveled)  
 Total Units 1 & 6 coal/coke plus fluxant (15% max): 3,462,938 PM = 0.04 x S<sup>2.3</sup> = 0.226 lb/VMT  
 Estimated biomass: 500,000 Assume vehicle speed (S) for grading and dozing occur at 2 miles per hour.

Emissions from transfer points are based on the following equation contained in AP-42 Section 13.2.4.1, Aggregate Handling and Storage Piles (1/95)

$$\text{Emission Factor (EF) (lb/ton)} = k \times (0.0032) \times (U/S)^{1.3} / (M/2)^{1.4}$$

where: k = dimensionless constant = 0.74 for PM, and 0.35 for PM<sub>10</sub>.

U = mean wind speed (mph) = 8.6 mph as measured at both Tampa and Orlando International Airports.

For enclosed transfer points, an air flow of 3 mph is assumed.

M = material moisture content (%) = 6.9% for coal.

EF(PM) = 0.074 x (0.0032) x (3/5)<sup>1.3</sup> / (6.9/2)<sup>1.4</sup> = 2.15E-04 (enclosed transfer point) WS = wet dust suppression system  
 EF(PM<sub>10</sub>) = 0.035 x (0.0032) x (3/5)<sup>1.3</sup> / (6.9/2)<sup>1.4</sup> = 1.02E-04 (enclosed transfer point) Residual = residual wet suppression  
 EF(PM) = 0.074 x (0.0032) x (6.6/5)<sup>1.3</sup> / (6.9/2)<sup>1.4</sup> = 8.46E-04 (exposed transfer point)  
 EF(PM<sub>10</sub>) = 0.035 x (0.0032) x (6.6/5)<sup>1.3</sup> / (6.9/2)<sup>1.4</sup> = 4.00E-04 (exposed transfer point)

Sources: Bechtel, 2007.  
ECT, 2007.



**Table A-25. Polk Power Station Unit 6 IGCC  
Material Handling Fugitive Source PM Emission Rates**

Area/Source Description	Max. Capacity (ton/hr)	Average Throughput (ton/yr)	Annual Operations (hrs/yr)	PM Emission Factor		Emission Control(s)	Control Efficiency (%)	Potential PM Emissions	
				Value	Units			(lb/hr)	(tpy)
<b>Rail Unloading Station Enclosure</b>									
Railcar to unloading bins	3,000	3,011,250	1,004	2.15E-04	lb/ton	WS	85	0.097	0.049
Unloading bins to 01-MH-002	3,000	3,011,250	1,004	2.15E-04	lb/ton	Residual	75	0.161	0.081
<b>Totals</b>								<b>0.258</b>	<b>0.130</b>
<b>Transfer Tower (01-AK-002) to Coal/Coke Storage Structure</b>									
01-MH-002 to 01-MH-004	3,000	2,162,625	721	2.15E-04	lb/ton	WS	85	0.097	0.035
01-MH-002 to 01-MH-007	3,000	2,162,625	721	2.15E-04	lb/ton	WS	85	0.097	0.035
01-MH-005 to 01-MH-006	500	848,625	1,697	2.15E-04	lb/ton	Residual	75	0.027	0.023
<b>Totals</b>								<b>0.221</b>	<b>0.093</b>
<b>Coal/Coke Storage Structure</b>									
Tripper MY-003 to coal/coke piles	3,000	2,162,625	721	2.15E-04	lb/ton	WS	85	0.097	0.035
Tripper MY-006 to coal/coke piles	500	848,625	1,697	2.15E-04	lb/ton	WS	85	0.016	0.014
Reclaimers MY-007A to 01-MH-008A/B	500	1,505,625	3,011	2.15E-04	lb/ton	Residual	75	0.027	0.041
Reclaimers MY-007B to 01-MH-008A/B	500	1,505,625	3,011	2.15E-04	lb/ton	Residual	75	0.027	0.041
01-MH-008A to 01-MH-009A/B	500	1,505,625	3,011	2.15E-04	lb/ton	Residual	75	0.027	0.041
01-MH-008B to 01-MH-009A/B	500	1,505,625	3,011	2.15E-04	lb/ton	Residual	75	0.027	0.041
<b>Totals</b>								<b>0.221</b>	<b>0.211</b>
<b>Emergency Storage Pile</b>									
01-MH-007 to stacking tube	3,000	3,011,250	1,004	8.46E-04	lb/ton	WS	85	0.381	0.191
Grading	1,000	3,011,250	3,011	2.26E-01	lb/VMT	WS	85	0.068	0.102
Dozer to reclaim bins	500	3,011,250	6,023	2.26E-01	lb/VMT	Residual	75	0.113	0.340
Reclaim bins to 01-MH-011	500	3,011,250	6,023	2.15E-04	lb/ton	Residual	75	0.027	0.081
01-MH-0011 to 01-MH-009A/B	500	3,011,250	6,023	2.15E-04	lb/ton	Residual	75	0.027	0.081
<b>Totals</b>								<b>0.616</b>	<b>0.796</b>
<b>Transfer Tower (01-AK-004) to Coal/Coke Silos</b>									
01-MH-009A to 01-MH-013A	500	1,505,625	3,011	2.15E-04	lb/ton	Residual	75	0.027	0.041
01-MH-009B to 01-MH-013B	500	1,505,625	3,011	2.15E-04	lb/ton	Residual	75	0.027	0.041
<b>Totals</b>								<b>0.054</b>	<b>0.081</b>
<b>Blending Area - Fuel Silos &amp; Fluxant Storage Bin</b>									
Coal/Coke to belt weigh feeders	1,000	3,011,250	3,011	2.15E-04	lb/ton	WS	85	0.032	0.049
Flux to belt weigh feeders	500	451,688	903	2.15E-04	lb/ton	WS	85	0.016	0.007
Belt weigh feeders to 01MH-024A/B	1,000	3,462,938	3,463	2.15E-04	lb/ton	WS	85	0.032	0.056
01MH-024A/B to Unit 6 via MH-026A/B	1,000	2,487,019	2,487	2.15E-04	lb/ton	WS	85	0.032	0.040
01MH-024A/B to Unit 1 via MH-025A/B	1,000	975,919	976	2.15E-04	lb/ton	WS	85	0.032	0.016
<b>Totals</b>								<b>0.145</b>	<b>0.168</b>
<b>Transfer Tower (01-AK-005) to Blended Fuel Hoppers</b>									
01-MH-026A/B to MH-027A/B	1,000	2,487,019	2,487	2.15E-04	lb/ton	Residual	75	0.054	0.067
01-MH-029 to MH-027A/B	500	500,000	1,000	2.15E-04	lb/ton	Residual	75	0.027	0.013
<b>Totals</b>								<b>0.081</b>	<b>0.080</b>
<b>Grinding Structure (blended fuel for Unit 1)</b>									
Fuel Storage Hoppers to weigh feeders	500	2,487,019	4,974	2.15E-04	lb/ton	Residual	75	0.027	0.067
<b>Totals</b>								<b>0.027</b>	<b>0.067</b>
<b>Inactive Coal Pile</b>									
01-MH-008A to conveyor	500	3,011,250	6,023	2.15E-04	lb/ton	Residual	75	0.027	0.081
Conveyor to conveyor	500	3,011,250	6,023	2.15E-04	lb/ton	Residual	75	0.027	0.081
Conveyor to inactive coal pile area	500	3,011,250	6,023	2.15E-04	lb/ton	Residual	75	0.027	0.081
Grading	1,000	3,011,250	3,011	2.26E-01	lb/VMT	WS	85	0.068	0.102
Dozing to dozer trap	500	3,011,250	6,023	2.26E-01	lb/VMT	Residual	75	0.113	0.340
Conveyor to conveyor	500	3,011,250	6,023	2.15E-04	lb/ton	Residual	75	0.027	0.081
Conveyor to transfer tower AK-002	500	3,011,250	6,023	2.15E-04	lb/ton	Residual	75	0.027	0.081
<b>Totals</b>								<b>0.315</b>	<b>0.848</b>
<b>Totals</b>								<b>1.937</b>	<b>2.472</b>

Notes:

Total Units 1 & 6 coal/pet coke: 3,011,250 Emission factors (EFs) for grading operations based on AP-42: Section 11.9 Western Surface Coal Mining dated October 1998.  
 Fluxant (max at 15% of coal/coke) 451,688  $PM_{10} = 0.60 \times 0.051 \times S^{2.0} = 0.122 \text{ lb/VMT}$  (VMT is vehicle miles traveled)  
 Total Units 1 & 6 coal/coke plus fluxant (15% max): 3,462,938  $PM = 0.04 \times S^{2.5} = 0.226 \text{ lb/VMT}$   
 Estimated biomass: 500,000 Assume vehicle speed (S) for grading and dozing occur at 2 miles per hour.

Emissions from transfer points are based on the following equation contained in AP-42 Section 13.2.4.1, Aggregate Handling and Storage Piles (1/95)

$$\text{Emission Factor (EF) (lb/ton)} = k \times (0.0032) \times (L/S)^{1.3} / (M/2)^{1.4}$$

where: k = dimensionless constant = 0.74 for PM, and 0.35 for  $PM_{10}$ .

U = mean wind speed (mph) = 8.6 mph as measured at both Tampa and Orlando International Airports.

For enclosed transfer points, an air flow of 3 mph is assumed.

M = material moisture content (%) = 6.9% for coal.

$EF(PM) = 0.074 \times (0.0032) \times (3/5)^{1.3} / (6.9/2)^{1.4} = 2.15E-04$  (enclosed transfer point) WS = wet dust suppression system  
 $EF(PM_{10}) = 0.035 \times (0.0032) \times (3/5)^{1.3} / (6.9/2)^{1.4} = 1.02E-04$  (enclosed transfer point) Residual = residual wet suppression  
 $EF(PM) = 0.074 \times (0.0032) \times (6.6/5)^{1.3} / (6.9/2)^{1.4} = 8.46E-04$  (exposed transfer point)  
 $EF(PM_{10}) = 0.035 \times (0.0032) \times (6.6/5)^{1.3} / (6.9/2)^{1.4} = 4.00E-04$  (exposed transfer point)

Sources: Bechtel, 2007.  
ECT, 2007.

**Table A-26. Polk Power Station Unit 6 IGCC  
Gasifier Feedstock Flow Rates**

**A. Each Gasifier, 100% Design Coal**

CT Load (%)	0°F Ambient Temperature			59°F Ambient Temperature			100°F Ambient Temperature		
	100	80	60	100	80	60	100	80	60
Case No.	1 - Syn	2 - Syn	3 - Syn	4 - Syn	5 - Syn	6 - Syn	7 - Syn	8 - Syn	9 - Syn
Heat Input - LHV (10 <sup>6</sup> Btu/hr)	3,088.5	2,597.5	2,186.4	2,966.2	2,488.0	2,064.2	2,941.0	2,290.2	1,913.2
Heat Input - HHV (10 <sup>6</sup> Btu/hr)	3,199.6	2,691.0	2,265.1	3,072.9	2,577.5	2,138.4	3,046.8	2,372.5	1,982.0
Feedstock Rate (lb/hr)	255,440	214,830	180,830	245,320	205,770	170,720	243,240	189,410	158,230
Feedstock Rate (ton/hr)	127.720	107.415	90.415	122.660	102.885	85.360	121.620	94.705	79.115
Feedstock Rate (ton/day)	3,065	2,578	2,170	2,944	2,469	2,049	2,919	2,273	1,899

**B. Both Gasifiers, 100% Design Coal**

CT Load (%)	0°F Ambient Temperature			59°F Ambient Temperature			100°F Ambient Temperature		
	100	80	60	100	80	60	100	80	60
Case No.	1 - Syn	2 - Syn	3 - Syn	4 - Syn	5 - Syn	6 - Syn	7 - Syn	8 - Syn	9 - Syn
Heat Input - LHV (10 <sup>6</sup> Btu/hr)	6,177.1	5,195.0	4,372.8	5,932.3	4,975.9	4,128.4	5,882.0	4,580.3	3,826.3
Heat Input - HHV (10 <sup>6</sup> Btu/hr)	6,399.3	5,381.9	4,530.2	6,145.8	5,155.0	4,276.9	6,093.6	4,745.1	3,964.0
Feedstock Rate (lb/hr)	510,880	429,660	361,660	490,640	411,540	341,440	486,480	378,820	316,460
Feedstock Rate (ton/hr)	255.440	214.830	180.830	245.320	205.770	170.720	243.240	189.410	158.230
Feedstock Rate (ton/day)	6,131	5,156	4,340	5,888	4,938	4,097	5,838	4,546	3,798

Sources: ECT, 2007  
GE, 2007.

**Table A-27. Polk Power Station Unit 6 IGCC  
CT/HRSG Fuel Flow Rates - Syngas**

**A. Each CT/HRSG Unit**

CT Load (%)	0°F Ambient Temperature			59°F Ambient Temperature			100°F Ambient Temperature		
	100	80	60	100	80	60	100	80	60
Case No.	1 - Syn	2 - Syn	3 - Syn	4 - Syn	5 - Syn	6 - Syn	7 - Syn	8 - Syn	9 - Syn
Heat Input - LHV (10 <sup>6</sup> Btu/hr)	2,371.5	1,994.5	1,678.8	2,277.6	1,910.3	1,585.0	2,258.2	1,758.4	1,469.0
Heat Input - HHV (10 <sup>6</sup> Btu/hr)	2,571.2	2,162.5	1,820.2	2,469.4	2,071.2	1,718.4	2,448.4	1,906.5	1,592.7
Fuel Rate (lb/hr)	584,360	491,467	413,689	561,221	470,725	390,555	556,455	433,306	361,984
Fuel Rate (lb/sec)	162.322	136.519	114.914	155.895	130.757	108.488	154.571	120.363	100.551
Fuel Rate (10 <sup>6</sup> ft <sup>3</sup> /hr)	10.4350	8.7762	7.3873	10.0218	8.4058	6.9742	9.9367	7.7376	6.4640

**B. Both CT/HRSG Units**

CT Load (%)	0°F Ambient Temperature			59°F Ambient Temperature			100°F Ambient Temperature		
	100	80	60	100	80	60	100	80	60
Case No.	1 - Syn	2 - Syn	3 - Syn	4 - Syn	5 - Syn	6 - Syn	7 - Syn	8 - Syn	9 - Syn
Heat Input - LHV (10 <sup>6</sup> Btu/hr)	4,742.9	3,989.0	3,357.7	4,555.1	3,820.6	3,169.9	4,516.4	3,516.9	2,938.0
Heat Input - HHV (10 <sup>6</sup> Btu/hr)	5,142.4	4,324.9	3,640.5	4,938.7	4,142.4	3,436.9	4,896.8	3,813.1	3,185.5
Fuel Rate (lb/hr)	1,168,720	982,934	827,378	1,122,442	941,450	781,110	1,112,910	866,611	723,968
Fuel Rate (lb/sec)	324.644	273.037	229.827	311.789	261.514	216.975	309.142	240.725	201.102
Fuel Rate (10 <sup>6</sup> ft <sup>3</sup> /hr)	20.8700	17.5524	14.7746	20.0436	16.8116	13.9484	19.8734	15.4752	12.9280

Sources: ECT, 2007  
GE, 2007.

**Table A-28. Polk Power Station Unit 6 IGCC  
CT/HRSG Fuel Flow Rates - Natural Gas**

**A. Each CT/HRSG Unit**

CT Load (%)	0°F Ambient Temperature			59°F Ambient Temperature			100°F Ambient Temperature		
	100	80	60	100	80	60	100	80	60
Case No.	1 - NG	2 - NG	3 - NG	4 - NG	5 - NG	6 - NG	7 - NG	8 - NG	9 - NG
Heat Input - LHV (10 <sup>6</sup> Btu/hr)	1,784.1	1,540.7	1,304.4	1,625.4	1,416.2	1,191.6	1,563.2	1,295.5	1,087.9
Heat Input - HHV (10 <sup>6</sup> Btu/hr)	1,980.1	1,710.0	1,447.8	1,804.1	1,571.8	1,322.5	1,735.0	1,437.9	1,207.5
Fuel Rate (lb/hr)	88,329	76,281	64,583	80,476	70,116	58,995	77,396	64,141	53,863
Fuel Rate (lb/sec)	24.536	21.189	17.940	22.354	19.477	16.388	21.499	17.817	14.962
Fuel Rate (10 <sup>6</sup> ft <sup>3</sup> /hr)	1.9413	1.6765	1.4194	1.7687	1.5410	1.2966	1.7010	1.4097	1.1838

**B. Both CT/HRSG Units**

CT Load (%)	0°F Ambient Temperature			59°F Ambient Temperature			100°F Ambient Temperature		
	100	80	60	100	80	60	100	80	60
Case No.	1 - NG	2 - NG	3 - NG	4 - NG	5 - NG	6 - NG	7 - NG	8 - NG	9 - NG
Heat Input - LHV (10 <sup>6</sup> Btu/hr)	3,568.1	3,081.4	2,608.9	3,250.9	2,832.4	2,383.2	3,126.4	2,591.0	2,175.8
Heat Input - HHV (10 <sup>6</sup> Btu/hr)	3,960.3	3,420.1	2,895.6	3,608.1	3,143.6	2,645.1	3,470.0	2,875.8	2,415.0
Fuel Rate (lb/hr)	176,658	152,562	129,165	160,952	140,231	117,991	154,791	128,283	107,726
Fuel Rate (lb/sec)	49.072	42.378	35.879	44.709	38.953	32.775	42.998	35.634	29.924
Fuel Rate (10 <sup>6</sup> ft <sup>3</sup> /hr)	3.8826	3.3530	2.8388	3.5374	3.0820	2.5932	3.4020	2.8194	2.3676

Sources: ECT, 2007  
GE, 2007.

**Table A-29. Polk Power Station Unit 6 IGCC  
CT/HRSO Exhaust Flow Rates - Syngas (Per CT/HRSO Unit)**

**A. Exhaust Composition**

Component	CT Load (%) Case No.	Exhaust Gas Composition - Volume %								
		0°F Ambient Temperature			59°F Ambient Temperature			100°F Ambient Temperature		
		100	80	60	100	80	60	100	80	60
		1 - Syn	2 - Syn	3 - Syn	4 - Syn	5 - Syn	6 - Syn	7 - Syn	8 - Syn	9 - Syn
Ar	MW (lb/lb-mole) 39.944	0.95	0.96	0.97	0.93	0.96	0.96	0.92	0.95	0.95
CO <sub>2</sub>	44.010	9.64	9.67	9.55	9.35	9.37	9.09	9.24	9.14	8.67
H <sub>2</sub> O	18.015	8.75	8.78	8.68	9.23	9.32	9.08	10.49	10.05	9.67
N <sub>2</sub>	28.013	71.22	70.44	70.36	71.19	69.98	70.02	70.17	69.30	69.49
O <sub>2</sub>	31.999	9.44	10.15	10.45	9.29	10.37	10.85	9.18	10.56	11.22
	Totals	100.00	100.00	100.01	99.99	100.00	100.00	100.00	100.00	100.00
Exhaust MW (lb/mole)		29.17	29.20	29.21	29.06	29.11	29.11	28.92	29.00	28.99
Exhaust Flow (lb/sec)		1,191.06	1,000.39	852.79	1,175.96	985.48	843.15	1,173.30	927.16	815.85
Exhaust Temperature (°F)		275	275	275	275	275	275	275	275	275
(K)		408	408	408	408	408	408	408	408	408
Exhaust O <sub>2</sub> (Vol % Dry)		10.35	11.13	11.44	10.23	11.44	11.93	10.26	11.74	12.42

**B. Exhaust Flow Rates**

Case No.	Flow Rates (ft <sup>3</sup> /min)								
	0°F Ambient Temperature			59°F Ambient Temperature			100°F Ambient Temperature		
	100	80	60	100	80	60	100	80	60
	1 - Syn	2 - Syn	3 - Syn	4 - Syn	5 - Syn	6 - Syn	7 - Syn	8 - Syn	9 - Syn
ACFM	1,310,482	1,099,515	937,085	1,298,566	1,086,596	929,715	1,302,186	1,025,936	903,107
Velocity (fps)	80.4	67.4	57.5	79.7	66.7	57.0	79.9	62.9	55.4
Velocity (m/s)	24.50	20.56	17.52	24.28	20.31	17.38	24.35	19.18	16.88
SCFM, Dry <sup>1</sup>	861,346	722,445	616,408	849,024	709,730	608,868	839,573	664,715	587,604
ACFM (15% O <sub>2</sub> , Dry)	2,139,251	1,661,382	1,371,685	2,130,734	1,580,559	1,284,627	2,102,830	1,432,755	1,172,350
SCFM (15% O <sub>2</sub> , Dry)	1,540,903	1,196,694	988,025	1,534,769	1,138,477	925,317	1,514,669	1,032,014	844,445

<sup>1</sup> At 68°F.

Sources: ECT, 2007  
GE, 2007.

**Table A-30. Polk Power Station Unit 6 IGCC  
CT/HRSG Exhaust Flow Rates - Natural Gas (Per CT/HRSG Unit)**

**A. Exhaust Composition**

Component		Exhaust Gas Composition - Volume %								
		0°F Ambient Temperature			59°F Ambient Temperature			100°F Ambient Temperature		
		100	80	60	100	80	60	100	80	60
Case No.		1 - NG	2 - NG	3 - NG	4 - NG	5 - NG	6 - NG	7 - NG	8 - NG	9 - NG
Ar	MW (lb/lb-mole) 39.944	0.85	0.84	0.85	0.84	0.84	0.84	0.83	0.83	0.84
CO <sub>2</sub>	44.010	3.66	3.90	3.92	3.66	3.78	3.71	3.67	3.71	3.53
H <sub>2</sub> O	18.015	12.31	12.86	12.59	13.45	13.46	12.70	14.75	14.12	12.92
N <sub>2</sub>	28.013	71.21	70.97	71.19	70.33	70.41	70.95	69.32	69.84	70.64
O <sub>2</sub>	31.999	11.97	11.43	11.46	11.73	11.51	11.80	11.44	11.51	12.08
Totals		100.00	100.00	100.01	100.01	100.00	100.00	100.01	100.01	100.01
Exhaust MW (lb/mole)		27.95	27.91	27.94	27.82	27.83	27.91	27.68	27.76	27.87
Exhaust Flow (lb/sec)		1,138.28	919.75	776.48	1,032.29	869.74	748.24	984.23	809.74	718.06
Exhaust Temperature (°F)		275	275	275	275	275	275	275	275	275
(K)		408	408	408	408	408	408	408	408	408
Exhaust O <sub>2</sub> (Vol %, Dry)		13.65	13.12	13.11	13.55	13.30	13.52	13.42	13.40	13.87

**B. Exhaust Flow Rates**

Case No.		Flow Rates (ft <sup>3</sup> /min)								
		0°F Ambient Temperature			59°F Ambient Temperature			100°F Ambient Temperature		
		100	80	60	100	80	60	100	80	60
		1 - NG	2 - NG	3 - NG	4 - NG	5 - NG	6 - NG	7 - NG	8 - NG	9 - NG
ACFM		1,307,246	1,057,765	891,866	1,190,718	1,002,982	860,508	1,141,069	936,333	826,891
Velocity (fps)		80.2	64.9	54.7	73.0	61.5	52.8	70.0	57.4	50.7
Velocity (m/s)		24.4	19.8	16.7	22.3	18.8	16.1	21.3	17.5	15.5
SCFM, Dry <sup>1</sup>		825,697	663,927	561,532	742,317	625,207	541,107	700,681	579,210	518,657
ACFM (15% O <sub>2</sub> , Dry)		1,408,548	1,215,939	1,029,226	1,283,341	1,118,046	940,098	1,233,370	1,021,860	857,685
SCFM (15% O <sub>2</sub> , Dry)		1,014,578	875,841	741,352	924,391	805,329	677,153	888,397	736,046	617,791

<sup>1</sup> At 68 °F.

Sources: ECT, 2007  
GE, 2007.

**Table A-31. Polk Power Station Unit 6  
Construction Excavation and Fill Operations PM / PM<sub>10</sub> Emission Rates**

---

**Total Cut/Fill Material**

Plant Area	96,800 cubic yards (at 1.5 ft of fill on 40 acres)
Laydown Area	278,300 cubic yards (at 3.0 ft of fill on 57.5 acres)
Total	375,100 cubic yards
	10,127,700 cubic feet
	455,747 tons (at 90 pounds per cubic feet)

Emissions from transfer points are based on the following equation contained in AP-42 Section 13.2.4.1, Aggregate Handling and Storage Piles (1/95).

$$\text{Emission Factor (EF) (lb/ton)} = k \times (0.0032) \times (U/5)^{1.3} / (M/2)^{1.4}$$

where: k = dimensionless constant = 0.74 for PM, and 0.35 for PM<sub>10</sub>.

U = mean wind speed (mph) = 8.6 mph as measured at Orlando International Airport.

M = material moisture content (%) = for soil 8%.

$$\text{EF(PM)} = 1.908\text{E-}04 \text{ lb/ton}$$

$$\text{EF(PM}_{10}\text{)} = 9.024\text{E-}05 \text{ lb/ton}$$

$$\text{PM} = 0.17 \text{ tpy (conservatively assumed that the material is transferred 4 times)}$$

$$\text{PM}_{10} = 0.08 \text{ tpy (conservatively assumed that the material is transferred 4 times)}$$

---

ECT, 2007.

**Table A-32. Polk Power Station Unit 6  
Construction Grading and Earth Moving Operations PM<sub>10</sub> Emission Rates**

Emission factors (EFs) for grading operations based on AP-42: Section 11.9 Western Surface Coal Mining dated October 1998.

$PM_{10} = 0.60 * .051 * (S)^{2.0} =$	0.122 lb/VMT
Vehicle speed (S)	2.00 mph
	2,600 hr/yr
	10 number of grading and earth moving equipment
Vehicle miles traveled (VMT)	52,000 VMT/yr
$PM_{10} =$	6,365 lb/yr
$PM_{10} =$	3.2 tpy

ECT, 2007.



**Table A-33. Polk Power Station Unit 6  
Construction Unpaved Roads PM<sub>10</sub> Emission Rates**

Emission Source Description: Unpaved Roads  
 Emission Control Method(s)/ID No.(s): Watering as needed  
 Emission Point Description: Fugitive

$$E = k * (s/12)^a * (W/3)^b \quad \text{Equation 1a of AP-42 Section 13.2.2}$$

E= particulate emission factor (having units matching the units of k)

k = particle size multiplier for particle size range and units of interest

s = road surface silt loading

W = average weight (tons) of the vehicles traveling the road

Daily VMT = round trip distance \* number of trucks/day

k	1.5	PM <sub>10</sub> , AP-42 Table 13.2.2-2
s	8.5	% (from AP-42: Table 13.2.2-1, mean for construction site)
W	30	Average vehicle weight (20 ton empty, 40 tons loaded)
a	0.90	PM <sub>10</sub> , AP-42 Table 13.2.2-2
b	0.45	PM <sub>10</sub> , AP-42 Table 13.2.2-2
EF	3.10	lb/VMT for PM <sub>10</sub>

	Material		Load (ton)	# trips/yr	Trip Length (mi)	VMT/yr	
	Fill	455,747	ton/yr	20	22,787	0.75	17,091
	Misc	22,787	ton/yr	20	1,139	1.00	1,139
	Totals	478,534			23,927		18,230
Criteria Pollutant	Emission Factor (lb/VMT)	Maximum Uncontrolled Rates		Control Efficiency (%)	Maximum Controlled Rates		
		(lb/hr)	(tpy)		(lb/hr)	(tpy)	
PM <sub>10</sub>	3.10	0.011	28.3	50	0.0054	14.1	

Notes:

Miscellaneous materials delivered was estimated to be 5% of total fill used.

Half of fill material was assumed to come from site excavation and half from offsite.

Source: ECT, 2007.

**Table A-34. Polk Power Station Unit 6  
Construction Wind Erosion PM<sub>10</sub> Emission Rates**

Total Area Disturbed (acrc)	Daily Percent Disturbed (%)	Daily Area Disturbed (acre/dy)	PM <sub>10</sub> Emission Factor (lb/acre/dy)	Construction Activity Level	Emission Control(s)	Control Efficiency (%)	PM <sub>10</sub> Emission Rates		
							Uncontrolled (lb/dy)	Controlled	
								(lb/dy)	(tpy)
240	95	228	1.70	inactive area	WS	95	387.6	19.4	2.5
240	5	12	6.30	active arca	WS	85	75.6	11.3	1.5
							<b>Total</b>		<b>4.0</b>

Notes:

PM<sub>10</sub> emission factors from Table 8.19.1-1 of the 4th Edition of U.S. EPA AP-42, September, 1991.

Emission controls assume wetting and crusting agents as needed.

WS - wet suppression

ECT, 2007.

**Table A-35. Polk Power Station Unit 6  
Construction Diesel Engine Emission Rates**

---

Heavy Equipment	30	total number
Operating Hours	2,600	hr/yr (10 hr/dy, 5 dy/wk, 52 wk/yr)
Fuel Use	5.0	gal/hr
Fuel Use	390,000	gal/yr
Engine Rating	500	hp
Diesel Fuel	7.0	lb/gal
Fuel Sulfur	0.0015	wt% S

	Emission Factor (gm/hp-hr)	Emissions (tpy)
PM <sub>10</sub>	0.15	6.4
NO <sub>x</sub>	2.5	107.5
SO <sub>2</sub>	0.0010	0.041
CO	0.84	36.2
VOC	0.17	7.2

---

ECT, 2007.

**Table A-36. Polk Power Station Unit 6  
CT/HRSG Units - Stack Parameters (Syngas)**

Parameter		Operating Case								
		Case 1	Case 2	Case 3	Case 4	Case 5	Case 6	Case 7	Case 8	Case 9
		Load (%) 100	80	60	100	80	60	100	80	60
	Ambient Temp. (°F)	0	59	100	0	59	100	0	59	100
Height	ft	175	175	175	175	175	175	175	175	175
Above Grade	m	53.3	53.3	53.3	53.3	53.3	53.3	53.3	53.3	53.3
Exit	ft	18.6	18.6	18.6	18.6	18.6	18.6	18.6	18.6	18.6
Diameter	m	5.67	5.67	5.67	5.67	5.67	5.67	5.67	5.67	5.67
Stack Area	ft <sup>2</sup>	271.7	271.7	271.7	271.7	271.7	271.7	271.7	271.7	271.7
Flow Rate	acfm	1,310,482	1,099,515	937,085	1,298,566	1,086,596	929,715	1,302,186	1,025,936	903,107
Exit	ft/sec	80.4	67.4	57.5	79.7	66.7	57.0	79.9	62.9	55.4
Velocity	m/sec	24.5	20.6	17.5	24.3	20.3	17.4	24.3	19.2	16.9
Exit	°F	275.0	275.0	275.0	275.0	275.0	275.0	275.0	275.0	275.0
Temperature	K	408.2	408.2	408.2	408.2	408.2	408.2	408.2	408.2	408.2

Sources: ECT, 2007.  
GE, 2007.

**Table A-37. Polk Power Station Unit 6  
CT/HRSG Units - Stack Parameters (Natural Gas)**

Parameter		Operating Case								
		Case 1	Case 2	Case 3	Case 4	Case 5	Case 6	Case 7	Case 8	Case 9
		Load (%) Ambient Temp. (°F)	100 0	80 59	60 100	100 0	80 59	60 100	100 0	80 59
Height Above Grade	ft	175	175	175	175	175	175	175	175	175
	m	53.3	53.3	53.3	53.3	53.3	53.3	53.3	53.3	53.3
Exit Diameter	ft	18.6	18.6	18.6	18.6	18.6	18.6	18.6	18.6	18.6
	m	5.67	5.67	5.67	5.67	5.67	5.67	5.67	5.67	5.67
Stack Area	ft <sup>2</sup>	271.7	271.7	271.7	271.7	271.7	271.7	271.7	271.7	271.7
Flow Rate	acfm	1,307,246	1,057,765	891,866	1,190,718	1,002,982	860,508	1,141,069	936,333	826,891
Exit Velocity	ft/sec	80.2	64.9	54.7	73.0	61.5	52.8	70.0	57.4	50.7
	m/sec	24.4	19.8	16.7	22.3	18.8	16.1	21.3	17.5	15.5
Exit Temperature	°F	275.0	275.0	275.0	275.0	275.0	275.0	275.0	275.0	275.0
	K	408.2	408.2	408.2	408.2	408.2	408.2	408.2	408.2	408.2

Sources: ECT, 2007.  
GE, 2007.

**Table A-38. Polk Power Station Unit 6  
Auxiliary Boiler, Emergency Diesel Engines,  
Sulfuric Acid Plant, and Cooling Tower Stack Parameters**

Parameter	Units	Emission Source				
		Auxiliary Boiler	Generator Diesel Engine	Fire Water Pump Diesel Engine	Sulfuric Acid Plant	Cooling Tower <sup>1</sup>
Height Above Grade	ft	100	18	12	275	42
	m	30.5	5.5	3.7	83.8	12.8
Exit Diameter	ft	5.0	0.8	0.7	6.5	37.5
	m	1.52	0.24	0.21	1.98	11.43
Stack Area	ft <sup>2</sup>	19.6	0.5	0.4	33.2	1,104.5
Flow Rate	acfm	70,686	10,601	2,080	57,739	1,789,235
Exit Velocity	ft/sec	60.0	351.5	90.1	29.0	27.0
	m/sec	18.3	107.1	27.5	8.8	8.2
Exit Temperature	°F	500.0	800.0	790.0	180.0	95.0
	K	533.2	699.8	694.3	355.4	308.2

<sup>1</sup> Per cell.

Sources: ECT, 2007.  
GE, 2007.

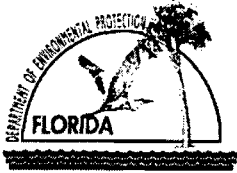

# Department of Environmental Protection

## Division of Air Resource Management

### APPLICATION FOR AIR PERMIT - LONG FORM

#### I. APPLICATION INFORMATION

**Air Construction Permit** – Use this form to apply for any air construction permit at a facility operating under a federally enforceable state air operation permit (FESOP) or Title V air permit. Also use this form to apply for an air construction permit:

- For a proposed project subject to prevention of significant deterioration (PSD) review, nonattainment area (NAA) new source review, or maximum achievable control technology (MACT) review; or
- Where the applicant proposes to assume a restriction on the potential emissions of one or more pollutants to escape a federal program requirement such as PSD review, NAA new source review, Title V, or MACT; or
- Where the applicant proposes to establish, revise, or renew a plantwide applicability limit (PAL).

**Air Operation Permit** – Use this form to apply for:

- An initial federally enforceable state air operation permit (FESOP); or
- An initial/revised/renewal Title V air operation permit.

**Air Construction Permit & Title V Air Operation Permit (Concurrent Processing Option)** – Use this form to apply for both an air construction permit and a revised or renewal Title V air operation permit incorporating the proposed project.

To ensure accuracy, please see form instructions.

#### Identification of Facility

1. Facility Owner/Company Name: <b>Tampa Electric Company</b>	
2. Site Name: <b>Polk Power Station</b>	
3. Facility Identification Number: <b>1050233</b>	
4. Facility Location... Street Address or Other Locator: <b>9895 State Road 37 South</b> City: <b>Mulberry</b> County: <b>Polk</b> Zip Code: <b>33860-0775</b>	
5. Relocatable Facility? <input type="checkbox"/> Yes <input checked="" type="checkbox"/> No	6. Existing Title V Permitted Facility? <input checked="" type="checkbox"/> Yes <input type="checkbox"/> No

#### Application Contact

1. Application Contact Name: <b>Paul L. Carpinone</b> <b>Director, Environmental, Health &amp; Safety</b>	
2. Application Contact Mailing Address Organization/Firm: <b>Tampa Electric Company</b> Street Address: <b>P.O. Box 111</b> City: <b>Tampa</b> State: <b>Florida</b> Zip Code: <b>33601-0111</b>	
3. Application Contact Telephone Numbers... Telephone: <b>(813) 228-4858</b> ext. Fax: <b>(813) 228-1308</b>	
4. Application Contact Email Address: <b>plcarpinone@tecoenergy.com</b>	

#### Application Processing Information (DEP Use)

1. Date of Receipt of Application: <b>9/11/07</b>	3. PSD Number (if applicable): <b>PSD-FL-394</b>
2. Project Number(s): <b>1050233-020-AC</b>	4. Siting Number (if applicable): <b>PA92-32</b>

## APPLICATION INFORMATION

### Purpose of Application

**This application for air permit is submitted to obtain: (Check one)**

#### **Air Construction Permit**

- Air construction permit.
- Air construction permit to establish, revise, or renew a plantwide applicability limit (PAL).
- Air construction permit to establish, revise, or renew a plantwide applicability limit (PAL), and separate air construction permit to authorize construction or modification of one or more emissions units covered by the PAL.

#### **Air Operation Permit**

- Initial Title V air operation permit.
- Title V air operation permit revision.
- Title V air operation permit renewal.
- Initial federally enforceable state air operation permit (FESOP) where professional engineer (PE) certification is required.
- Initial federally enforceable state air operation permit (FESOP) where professional engineer (PE) certification is not required.

#### **Air Construction Permit and Revised/Renewal Title V Air Operation Permit (Concurrent Processing)**

- Air construction permit and Title V permit revision, incorporating the proposed project.
- Air construction permit and Title V permit renewal, incorporating the proposed project.

**Note: By checking one of the above two boxes, you, the applicant, are requesting concurrent processing pursuant to Rule 62-213.405, F.A.C. In such case, you must also check the following box:**

- I hereby request that the department waive the processing time requirements of the air construction permit to accommodate the processing time frames of the Title V air operation permit.

### Application Comment

**PSD air construction permit application for a nominal 630-megawatt (MW), net (790-MW, gross) integrated gasification combined cycle (IGCC) power plant. The IGCC facility, referred to as Unit 6, will be located at the existing Polk Power Station (PPS) in southwest Polk County. A detailed description of the Unit 6 project is provided in Section 2.0.**

**Unit 6 is being licensed under the Florida Electrical Power Plant Siting Act (FEPPSA).**



**APPLICATION INFORMATION**

**Scope of Application**

Emissions Unit ID Number	Description of Emissions Unit	Air Permit Type	Air Permit Proc. Fee
011	Unit 6 CT/HRSG No. 1	AC1A	
012	Unit 6 CT/HRSG No. 2	AC1A	
013	Unit 6 Auxiliary Boiler	AC1A	
014	Unit 6 Cooling Tower	AC1A	
015	Unit 6 Sulfuric Acid Plant	AC1A	
016	Unit 6 Flare	AC1A	
017	Unit 6 Gasification Feedstock and Byproduct Material Handling and Storage Systems	AC1A	
018	Unit 6 Emergency Generator Diesel Engine	AC1A	
019	Unit 6 Emergency Firewater Pump Diesel Engine No. 1	AC1A	
020	Unit 6 Emergency Firewater Pump Diesel Engine No. 2	AC1A	

**Application Processing Fee**

Check one:  Attached - Amount: \$ 7,500       Not Applicable

**Application processing fee of \$7,500 is required pursuant to Rule 62-4.050(4)(a)1, F.A.C.**

## APPLICATION INFORMATION

### Owner/Authorized Representative Statement

**Complete if applying for an air construction permit or an initial FESOP.**

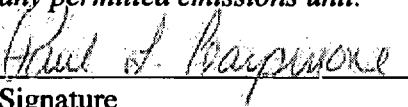
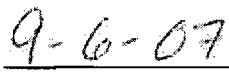
1. Owner/Authorized Representative Name: <b>Paul L. Carpinone, Director, Environmental, Health &amp; Safety</b>
2. Owner/Authorized Representative Mailing Address Organization/Firm: <b>Tampa Electric Company</b> Street Address: <b>P.O. Box 111</b> City: <b>Tampa</b> State: <b>Florida</b> Zip Code: <b>33601-0111</b>
3. Owner/Authorized Representative Telephone Numbers Telephone: Telephone: <b>(813) 228-4858</b> ext. Fax: <b>(813) 228-1308</b>
4. Owner/Authorized Representative Email Address: <b>plcarpinone@tecoenergy.com</b>
5. Owner/Authorized Representative Statement:  <i>I, the undersigned, am the owner or authorized representative of the facility addressed in this air permit application. I hereby certify, based on information and belief formed after reasonable inquiry, that the statements made in this application are true, accurate and complete and that, to the best of my knowledge, any estimates of emissions reported in this application are based upon reasonable techniques for calculating emissions. The air pollutant emissions units and air pollution control equipment described in this application will be operated and maintained so as to comply with all applicable standards for control of air pollutant emissions found in the statutes of the State of Florida and rules of the Department of Environmental Protection and revisions thereof and all other requirements identified in this application to which the facility is subject. I understand that a permit, if granted by the department, cannot be transferred without authorization from the department, and I will promptly notify the department upon sale or legal transfer of the facility or any permitted emissions unit.</i>   Signature  Date

APPLICATION INFORMATION

Owner/Authorized Representative Statement

Complete if applying for an air construction permit or an initial FESOP.

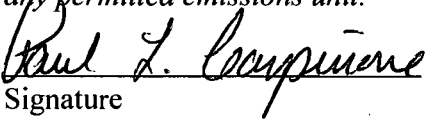
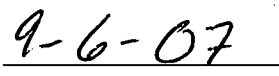
1. Owner/Authorized Representative Name: <b>Paul L. Carpinone, Director, Environmental, Health &amp; Safety</b>
2. Owner/Authorized Representative Mailing Address Organization/Firm: <b>Tampa Electric Company</b> Street Address: <b>P.O. Box 111</b> City: <b>Tampa</b> State: <b>Florida</b> Zip Code: <b>33601-0111</b>
3. Owner/Authorized Representative Telephone Numbers Telephone: Telephone: <b>(813) 228-4858</b> ext. Fax: <b>(813) 228-1308</b>
4. Owner/Authorized Representative Email Address: <b>plcarpinone@tecoenergy.com</b>
5. Owner/Authorized Representative Statement:  <i>I, the undersigned, am the owner or authorized representative of the facility addressed in this air permit application. I hereby certify, based on information and belief formed after reasonable inquiry, that the statements made in this application are true, accurate and complete and that, to the best of my knowledge, any estimates of emissions reported in this application are based upon reasonable techniques for calculating emissions. The air pollutant emissions units and air pollution control equipment described in this application will be operated and maintained so as to comply with all applicable standards for control of air pollutant emissions found in the statutes of the State of Florida and rules of the Department of Environmental Protection and revisions thereof and all other requirements identified in this application to which the facility is subject. I understand that a permit, if granted by the department, cannot be transferred without authorization from the department, and I will promptly notify the department upon sale or legal transfer of the facility or any permitted emissions unit.</i>   Signature   Date

**APPLICATION INFORMATION**

**Scope of Application**

Emissions Unit ID Number	Description of Emissions Unit	Air Permit Type	Air Permit Proc. Fee
011	Unit 6 Combined Cycle Unit 1	AC1A	
012	Unit 6 Combined Cycle Unit 2	AC1A	
013	Unit 6 Auxiliary Boiler	AC1A	
014	Unit 6 Cooling Tower	AC1A	
015	Unit 6 Sulfuric Acid Plant	AC1A	
016	Unit 6 Flare	AC1A	
017	Unit 6 Gasification Feedstock and Byproduct Material Handling and Storage Systems	AC1A	
018	Unit 6 Emergency Generator Diesel Engine	AC1A	
019	Unit 6 Emergency Firewater Pumps Diesel Engines	AC1A	

**Application Processing Fee**

Check one:  Attached - Amount: \$ 7,500       Not Applicable

**Application processing fee of \$7,500 is required pursuant to Rule 62-4.050(4)(a)1, F.A.C.**

**APPLICATION INFORMATION**

**Application Responsible Official Certification NOT APPLICABLE**

**Complete if applying for an initial/revised/renewal Title V permit or concurrent processing of an air construction permit and a revised/renewal Title V permit. If there are multiple responsible officials, the “application responsible official” need not be the “primary responsible official.”**

1. Application Responsible Official Name:
2. Application Responsible Official Qualification (Check one or more of the following options, as applicable): <input type="checkbox"/> For a corporation, the president, secretary, treasurer, or vice-president of the corporation in charge of a principal business function, or any other person who performs similar policy or decision-making functions for the corporation, or a duly authorized representative of such person if the representative is responsible for the overall operation of one or more manufacturing, production, or operating facilities applying for or subject to a permit under Chapter 62-213, F.A.C. <input type="checkbox"/> For a partnership or sole proprietorship, a general partner or the proprietor, respectively. <input type="checkbox"/> For a municipality, county, state, federal, or other public agency, either a principal executive officer or ranking elected official. <input type="checkbox"/> The designated representative at an Acid Rain source.
3. Application Responsible Official Mailing Address... Organization/Firm: Street Address: <div style="display: flex; justify-content: space-between; margin-top: 10px;"> <span>City:</span> <span>State:</span> <span>Zip Code:</span> </div>
4. Application Responsible Official Telephone Numbers... Telephone: ( ) - ext. Fax: ( ) -
5. Application Responsible Official Email Address:
6. Application Responsible Official Certification:  <i>I, the undersigned, am a responsible official of the Title V source addressed in this air permit application. I hereby certify, based on information and belief formed after reasonable inquiry, that the statements made in this application are true, accurate and complete and that, to the best of my knowledge, any estimates of emissions reported in this application are based upon reasonable techniques for calculating emissions. The air pollutant emissions units and air pollution control equipment described in this application will be operated and maintained so as to comply with all applicable standards for control of air pollutant emissions found in the statutes of the State of Florida and rules of the Department of Environmental Protection and revisions thereof and all other applicable requirements identified in this application to which the Title V source is subject. I understand that a permit, if granted by the department, cannot be transferred without authorization from the department, and I will promptly notify the department upon sale or legal transfer of the facility or any permitted emissions unit. Finally, I certify that the facility and each emissions unit are in compliance with all applicable requirements to which they are subject, except as identified in compliance plan(s) submitted with this application.</i>  <div style="display: flex; justify-content: space-between; margin-top: 20px;"> <div style="width: 45%; border-top: 1px solid black; text-align: center;">Signature</div> <div style="width: 45%; border-top: 1px solid black; text-align: center;">Date</div> </div>

# APPLICATION INFORMATION

## Professional Engineer Certification

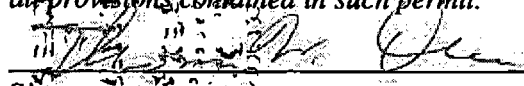
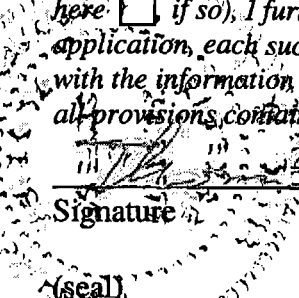
1. Professional Engineer Name: <b>Thomas W. Davis</b> Registration Number: <b>36777</b>
2. Professional Engineer Mailing Address Organization/Firm: <b>Environmental Consulting &amp; Technology, Inc.</b> Street Address: <b>3701 Northwest 98<sup>th</sup> Street</b> City: <b>Gainesville</b> State: <b>FL</b> Zip Code: <b>32606</b>
3. Professional Engineer Telephone Numbers... Telephone: <b>(352) 332-6230</b> ext. <b>11351</b> Fax: <b>(352) 332-6722</b>
4. Professional Engineer Email Address: <b>tdavis@ectinc.com</b>
5. Professional Engineer Statement: <i>I, the undersigned, hereby certify, except as particularly noted herein*, that:</i> <i>(1) To the best of my knowledge, there is reasonable assurance that the air pollutant emissions unit(s) and the air pollution control equipment described in this application for air permit, when properly operated and maintained, will comply with all applicable standards for control of air pollutant emissions found in the Florida Statutes and rules of the Department of Environmental Protection; and</i> <i>(2) To the best of my knowledge, any emission estimates reported or relied on in this application are true, accurate, and complete and are either based upon reasonable techniques available for calculating emissions or, for emission estimates of hazardous air pollutants not regulated for an emissions unit addressed in this application, based solely upon the materials, information and calculations submitted with this application.</i> <i>(3) If the purpose of this application is to obtain a Title V air operation permit (check here <input type="checkbox"/> if so), I further certify that each emissions unit described in this application for air permit, when properly operated and maintained, will comply with the applicable requirements identified in this application to which the unit is subject, except those emissions units for which a compliance plan and schedule is submitted with this application.</i> <i>(4) If the purpose of this application is to obtain an air construction permit (check here <input checked="" type="checkbox"/> if so) or concurrently process and obtain an air construction permit and a Title V air operation permit revision or renewal for one or more proposed new or modified emissions units (check here <input type="checkbox"/> if so), I further certify that the engineering features of each such emissions unit described in this application have been <del>designed or</del> examined by me or individuals under my direct supervision and found to be in conformity with sound engineering principles applicable to the control of emissions of the air pollutants characterized in this application.</i> <i>(5) If the purpose of this application is to obtain an initial air operation permit or operation permit revision or renewal for one or more newly constructed or modified emissions units (check here <input type="checkbox"/> if so), I further certify that, with the exception of any changes detailed as part of this application, each such emissions unit has been constructed or modified in substantial accordance with the information given in the corresponding application for air construction permit and with all provisions contained in such permit.</i>  Signature _____ Date <u>9/10/07</u>  (seal)

\* Attach any exception to certification statement.

**APPLICATION INFORMATION**

**Professional Engineer Certification**

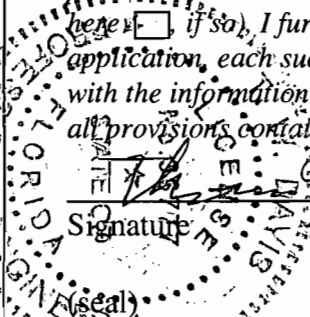
1. Professional Engineer Name: <b>Thomas W. Davis</b> Registration Number: <b>36777</b>
2. Professional Engineer Mailing Address Organization/Firm: <b>Environmental Consulting &amp; Technology, Inc.</b> Street Address: <b>3701 Northwest 98<sup>th</sup> Street</b> City: <b>Gainesville</b> State: <b>FL</b> Zip Code: <b>32606</b>
3. Professional Engineer Telephone Numbers... Telephone: <b>(352) 332-6230</b> ext. <b>11351</b> Fax: <b>(352) 332-6722</b>
4. Professional Engineer Email Address: <b>tdavis@ectinc.com</b>
5. Professional Engineer Statement: <i>I, the undersigned, hereby certify, except as particularly noted herein*, that:</i> <i>(1) To the best of my knowledge, there is reasonable assurance that the air pollutant emissions unit(s) and the air pollution control equipment described in this application for air permit, when properly operated and maintained, will comply with all applicable standards for control of air pollutant emissions found in the Florida Statutes and rules of the Department of Environmental Protection; and</i> <i>(2) To the best of my knowledge, any emission estimates reported or relied on in this application are true, accurate, and complete and are either based upon reasonable techniques available for calculating emissions or, for emission estimates of hazardous air pollutants not regulated for an emissions unit addressed in this application, based solely upon the materials, information and calculations submitted with this application.</i> <i>(3) If the purpose of this application is to obtain a Title V air operation permit (check here <input type="checkbox"/> if so), I further certify that each emissions unit described in this application for air permit, when properly operated and maintained, will comply with the applicable requirements identified in this application to which the unit is subject, except those emissions units for which a compliance plan and schedule is submitted with this application.</i> <i>(4) If the purpose of this application is to obtain an air construction permit (check here <input checked="" type="checkbox"/> if so) or concurrently process and obtain an air construction permit and a Title V air operation permit revision or renewal for one or more proposed new or modified emissions units (check here <input type="checkbox"/> if so), I further certify that the engineering features of each such emissions unit described in this application have been <del>designed</del> or examined by me or individuals under my direct supervision and found to be in conformity with sound engineering principles applicable to the control of emissions of the air pollutants characterized in this application.</i> <i>(5) If the purpose of this application is to obtain an initial air operation permit or operation permit revision or renewal for one or more newly constructed or modified emissions units (check here <input type="checkbox"/> if so), I further certify that, with the exception of any changes detailed as part of this application, each such emissions unit has been constructed or modified in substantial accordance with the information given in the corresponding application for air construction permit and with all provisions contained in such permit.</i>  Signature: <u><i>Thomas W. Davis</i></u> Date: <u>9/10/07</u>

\* Attach any exception to certification statement.

**II. FACILITY INFORMATION**

**A. GENERAL FACILITY INFORMATION**

**Facility Location and Type**

1. Facility UTM Coordinates... Zone <b>17</b> East (km) <b>402.45</b> North (km) <b>3,067.35</b>		2. Facility Latitude/Longitude... Latitude (DD/MM/SS) <b>27/43/43</b> Longitude (DD/MM/SS) <b>81/59/23</b>	
3. Governmental Facility Code: <b>0</b>	4. Facility Status Code: <b>A</b>	5. Facility Major Group SIC Code: <b>49</b>	6. Facility SIC(s): <b>4911</b>
7. Facility Comment :			

**Facility Contact**

1. Facility Contact Name: <b>Mike Perkins, Environmental Coordinator</b>
2. Facility Contact Mailing Address Organization/Firm: <b>Tampa Electric Company</b> Street Address: <b>P.O. Box 111</b> City: <b>Tampa</b> State: <b>Florida</b> Zip Code: <b>33601-0111</b>
3. Facility Contact Telephone Numbers: Telephone: <b>(813) 228-1111 ext. 39109</b> Fax: <b>(863) 428-5927</b>
4. Facility Contact Email Address: <b>mrperkins@tecoenergy.com</b>

**Facility Primary Responsible Official**

<b>NOT APPLICABLE</b>
-----------------------

**Complete if an “application responsible official” is identified in Section I. that is not the facility “primary responsible official.”**

1. Facility Primary Responsible Official Name:
2. Facility Primary Responsible Official Mailing Address... Organization/Firm: Street Address: City: State: Zip Code:
3. Facility Primary Responsible Official Telephone Numbers... Telephone: ( ) - ext. Fax: ( ) -
4. Facility Primary Responsible Official Email Address:



**Facility Regulatory Classifications**

**Check all that would apply *following* completion of all projects and implementation of all other changes proposed in this application for air permit. Refer to instructions to distinguish between a “major source” and a “synthetic minor source.”**

1. <input type="checkbox"/> Small Business Stationary Source	<input type="checkbox"/> Unknown
2. <input type="checkbox"/> Synthetic Non-Title V Source	
3. <input checked="" type="checkbox"/> Title V Source	
4. <input checked="" type="checkbox"/> Major Source of Air Pollutants, Other than Hazardous Air Pollutants (HAPs)	
5. <input type="checkbox"/> Synthetic Minor Source of Air Pollutants, Other than HAPs	
6. <input type="checkbox"/> Major Source of Hazardous Air Pollutants (HAPs)	
7. <input checked="" type="checkbox"/> Synthetic Minor Source of HAPs	
8. <input checked="" type="checkbox"/> One or More Emissions Units Subject to NSPS (40 CFR 60)	
9. <input type="checkbox"/> One or More Emissions Units Subject to Emission Guidelines (40 CFR 60)	
10. <input type="checkbox"/> One or More Emissions Units Subject to NESHAP (40 CFR 61 or Part 63)	
11. <input type="checkbox"/> Title V Source Solely by EPA Designation (40 CFR 70.3(a)(5))	
12. Facility Regulatory Classifications Comment:	
<p style="text-align: center;"><b>Applicable State and Federal emission standards are discussed in Section 4.0.</b></p>	

**List of Pollutants Emitted by Facility**

1. Pollutant Emitted	2. Pollutant Classification	3. Emissions Cap [Y or N]?
<b>NO<sub>x</sub></b>	<b>A</b>	<b>N</b>
<b>SO<sub>2</sub></b>	<b>A</b>	<b>N</b>
<b>PM</b>	<b>A</b>	<b>N</b>
<b>PM<sub>10</sub></b>	<b>A</b>	<b>N</b>
<b>CO</b>	<b>A</b>	<b>N</b>
<b>VOC</b>	<b>A</b>	<b>N</b>
<b>SAM</b>	<b>A</b>	<b>N</b>
<b>PB</b>	<b>B</b>	<b>N</b>
<b>Arsenic Compounds (H015)</b>	<b>B</b>	<b>N</b>
<b>Beryllium Compounds (H021)</b>	<b>B</b>	<b>N</b>
<b>Mercury Compounds (H114)</b>	<b>B</b>	<b>N</b>

## B. EMISSIONS CAPS

**Facility-Wide or Multi-Unit Emissions Caps** **NOT APPLICABLE**

1. Pollutant Subject to Emissions Cap	2. Facility Wide Cap [Y or N]? (all units)	3. Emissions Unit ID No.s Under Cap (if not all units)	4. Hourly Cap (lb/hr)	5. Annual Cap (ton/yr)	6. Basis for Emissions Cap
<b>7. Facility-Wide or Multi-Unit Emissions Cap Comment:</b>					

### C. FACILITY ADDITIONAL INFORMATION

#### Additional Requirements for All Applications, Except as Otherwise Stated

1. Facility Plot Plan: (Required for all permit applications, except Title V air operation permit revision applications if this information was submitted to the department within the previous five years and would not be altered as a result of the revision being sought) <input checked="" type="checkbox"/> Attached, Document ID: <b>Section 2.0</b> <input type="checkbox"/> Previously Submitted, Date: _____
2. Process Flow Diagram(s): (Required for all permit applications, except Title V air operation permit revision applications if this information was submitted to the department within the previous five years and would not be altered as a result of the revision being sought) <input checked="" type="checkbox"/> Attached, Document ID: <b>Section 2.0</b> <input type="checkbox"/> Previously Submitted, Date: _____
3. Precautions to Prevent Emissions of Unconfined Particulate Matter: (Required for all permit applications, except Title V air operation permit revision applications if this information was submitted to the department within the previous five years and would not be altered as a result of the revision being sought) <input checked="" type="checkbox"/> Attached, Document ID: <b>Section 5.0</b> <input type="checkbox"/> Previously Submitted, Date: _____

#### Additional Requirements for Air Construction Permit Applications

1. Area Map Showing Facility Location: <input checked="" type="checkbox"/> Attached, Document ID: <b>Section 2.0</b> <input type="checkbox"/> Not Applicable (existing permitted facility)
2. Description of Proposed Construction, Modification, or Plantwide Applicability Limit (PAL): <input checked="" type="checkbox"/> Attached, Document ID: <b>Section 2.0</b>
3. Rule Applicability Analysis: <input checked="" type="checkbox"/> Attached, Document ID: <b>Section 4.0</b>
4. List of Exempt Emissions Units (Rule 62-210.300(3), F.A.C.): <input type="checkbox"/> Attached, Document ID: _____ <input checked="" type="checkbox"/> Not Applicable (no exempt units at facility)
5. Fugitive Emissions Identification: <input checked="" type="checkbox"/> Attached, Document ID: <b>Section 2.0</b> <input type="checkbox"/> Not Applicable
6. Air Quality Analysis (Rule 62-212.400(7), F.A.C.): <input checked="" type="checkbox"/> Attached, Document ID: <b>Section 8.0</b> <input type="checkbox"/> Not Applicable
7. Source Impact Analysis (Rule 62-212.400(5), F.A.C.): <input checked="" type="checkbox"/> Attached, Document ID: <b>Sections 7.0 and 10.0</b> <input type="checkbox"/> Not Applicable
8. Air Quality Impact since 1977 (Rule 62-212.400(4)(e), F.A.C.): <input checked="" type="checkbox"/> Attached, Document ID: <b>Section 9.0</b> <input type="checkbox"/> Not Applicable
9. Additional Impact Analyses (Rules 62-212.400(8) and 62-212.500(4)(e), F.A.C.): <input checked="" type="checkbox"/> Attached, Document ID: <b>Section 9.0</b> <input type="checkbox"/> Not Applicable
10. Alternative Analysis Requirement (Rule 62-212.500(4)(g), F.A.C.): <input type="checkbox"/> Attached, Document ID: _____ <input checked="" type="checkbox"/> Not Applicable

**Additional Requirements for FESOP Applications** **NOT APPLICABLE**

1. List of Exempt Emissions Units (Rule 62-210.300(3)(a) or (b)1., F.A.C.):  
 Attached, Document ID: \_\_\_\_\_  Not Applicable (no exempt units at facility)

**Additional Requirements for Title V Air Operation Permit Applications** **NOT APPLICABLE**

1. List of Insignificant Activities (Required for initial/renewal applications only):  
 Attached, Document ID: \_\_\_\_\_  Not Applicable (revision application)

2. Identification of Applicable Requirements (Required for initial/renewal applications, and for revision applications if this information would be changed as a result of the revision being sought):  
 Attached, Document ID: \_\_\_\_\_  
 Not Applicable (revision application with no change in applicable requirements)

3. Compliance Report and Plan (Required for all initial/revision/renewal applications):  
 Attached, Document ID: \_\_\_\_\_  
Note: A compliance plan must be submitted for each emissions unit that is not in compliance with all applicable requirements at the time of application and/or at any time during application processing. The department must be notified of any changes in compliance status during application processing.

4. List of Equipment/Activities Regulated under Title VI (If applicable, required for initial/renewal applications only):  
 Attached, Document ID: \_\_\_\_\_  
 Equipment/Activities On site but Not Required to be Individually Listed  
 Not Applicable

5. Verification of Risk Management Plan Submission to EPA (If applicable, required for initial/renewal applications only) :  
 Attached, Document ID: \_\_\_\_\_  Not Applicable

6. Requested Changes to Current Title V Air Operation Permit:  
 Attached, Document ID: \_\_\_\_\_  Not Applicable

**Additional Requirements Comment**

**EMISSIONS UNIT INFORMATION**

Section [ 1 ] of [ 10 ]

**A. GENERAL EMISSIONS UNIT INFORMATION**

**Title V Air Operation Permit Emissions Unit Classification**

1. Regulated or Unregulated Emissions Unit? (Check one, if applying for an initial, revised or renewal Title V air operation permit. Skip this item if applying for an air construction permit or FESOP only.) N/A

The emissions unit addressed in this Emissions Unit Information Section is a regulated emissions unit.

The emissions unit addressed in this Emissions Unit Information Section is an unregulated emissions unit.

**Emissions Unit Description and Status**

1. Type of Emissions Unit Addressed in this Section: (Check one)

This Emissions Unit Information Section addresses, as a single emissions unit, a single process or production unit, or activity, which produces one or more air pollutants and which has at least one definable emission point (stack or vent).

This Emissions Unit Information Section addresses, as a single emissions unit, a group of process or production units and activities which has at least one definable emission point (stack or vent) but may also produce fugitive emissions.

This Emissions Unit Information Section addresses, as a single emissions unit, one or more process or production units and activities which produce fugitive emissions only.

2. Description of Emissions Unit Addressed in this Section:

**GE 7FB combustion turbine (CT) and unfired recovery steam generator (HRSG). The CT may be fired with either syngas or pipeline natural gas. CT/HRSG No. 1 shares a common steam turbine with CT/HRSG No. 2.**

3. Emissions Unit Identification Number: **011 (Unit 6 CT/HRSG No. 1)**

4. Emissions Unit Status Code:  
**C**

5. Commence Construction Date:  
**N/A**

6. Initial Startup Date:  
**N/A**

7. Emissions Unit Major Group SIC Code:  
**49**

8. Acid Rain Unit?  
 Yes  
 No

9. Package Unit:

Manufacturer:

Model Number:

10. Generator Nameplate Rating: **790-MW, gross 630-MW, net (nominal)**

11. Emissions Unit Comment:

**Generator nameplate ratings are total nominal generation capacities for Unit 6 CT/HRSG No. 1, CT/HRSG No. 2, and common steam turbine.**

**EMISSIONS UNIT INFORMATION**

Section [ 1 ] of [ 10 ]

**Emissions Unit Control Equipment**

1. Control Equipment/Method(s) Description:

**Syngas**

**NO<sub>x</sub> – Nitrogen Diluent**

– Syngas Moisturization

– Selective Catalytic Reduction (SCR) [139]

**Natural Gas**

**NO<sub>x</sub> – Wet Injection [028]**

– Selective Catalytic Reduction (SCR) [139]

2. Control Device or Method Code(s): **Syngas (139), Natural Gas (028, 139)**

**EMISSIONS UNIT INFORMATION**

Section [ 1 ] of [ 10 ]

**B. EMISSIONS UNIT CAPACITY INFORMATION**

(Optional for unregulated emissions units.)

**Emissions Unit Operating Capacity and Schedule**

1. Maximum Process or Throughput Rate: N/A
2. Maximum Production Rate: N/A
3. Maximum Heat Input Rate: <b>3,200</b> million Btu/hr, <b>HHV</b>
4. Maximum Incineration Rate: N/A pounds/hr tons/day
5. Requested Maximum Operating Schedule: 24 hours/day 7 days/week 52 weeks/year 8,760 hours/year
6. Operating Capacity/Schedule Comment:  <b>Maximum heat input shown above is the Train No. 1 gasifier heat input at 100% load and 0°F ambient temperature, on a higher heating value basis (HHV).</b>  <b>Maximum CT heat input for the Unit 6 CT/HRSG No. 1 during natural gas-firing is 1,980 x 10<sup>6</sup> Btu/hr at 100% load and 0°F ambient temperature, HHV basis.</b>



**EMISSIONS UNIT INFORMATION**

Section [ 1 ] of [ 10 ]

**C. EMISSION POINT (STACK/VENT) INFORMATION**  
 (Optional for unregulated emissions units.)

**Emission Point Description and Type**

1. Identification of Point on Plot Plan or Flow Diagram: <b>Unit 6 CT/HRSG No. 1</b>		2. Emission Point Type Code: <b>1</b>	
3. Descriptions of Emission Points Comprising this Emissions Unit for VE Tracking:  <b>N/A</b>			
4. ID Numbers or Descriptions of Emission Units with this Emission Point in Common:  <b>N/A</b>			
5. Discharge Type Code: <b>V</b>	6. Stack Height: <b>175 feet</b>	7. Exit Diameter: <b>18.6 feet</b>	
8. Exit Temperature: <b>275 °F</b>	9. Actual Volumetric Flow Rate: <b>1,298,566 acfm</b>	10. Water Vapor: <b>N/A %</b>	
11. Maximum Dry Standard Flow Rate: <b>N/A dscfm</b>		12. Nonstack Emission Point Height: <b>N/A feet</b>	
13. Emission Point UTM Coordinates Zone: <b>17</b> East (km): <b>402.53</b> North (km): <b>3,066.79</b>		14. Emission Point Latitude/Longitude <b>N/A</b> Latitude (DD/MM/SS) <b>N/A</b> Longitude (DD/MM/SS)	
15. Emission Point Comment:  <b>Exit temperature (Field 8) and volumetric flow rate (Field 9) for are syngas Operating Case No. 4 – 100% load and 59°F ambient temperature.</b>			

**EMISSIONS UNIT INFORMATION**

Section [ 1 ] of [ 10 ]

**D. SEGMENT (PROCESS/FUEL) INFORMATION**

**Segment Description and Rate: Segment 1 of 2**

1. Segment Description (Process/Fuel Type):  <b>Combustion turbine fired with coal-derived syngas.</b>		
2. Source Classification Code (SCC): <b>1-01-019-01</b>		3. SCC Units: <b>Million Cubic Feet Burned</b>
4. Maximum Hourly Rate: <b>10.44</b>	5. Maximum Annual Rate: <b>91,454.4</b>	6. Estimated Annual Activity Factor: <b>N/A</b>
7. Maximum % Sulfur: <b>&lt;0.1</b>	8. Maximum % Ash: <b>N/A</b>	9. Million Btu per SCC Unit: <b>246, HHV</b>
10. Segment Comment:		

**Segment Description and Rate: Segment 2 of 2**

1. Segment Description (Process/Fuel Type):  <b>Combustion turbine fired with pipeline natural gas.</b>		
2. Source Classification Code (SCC): <b>2-01-002-01</b>		3. SCC Units: <b>Million Cubic Feet Burned</b>
4. Maximum Hourly Rate: <b>1.94</b>	5. Maximum Annual Rate: <b>16,994.4</b>	6. Estimated Annual Activity Factor: <b>N/A</b>
7. Maximum % Sulfur: <b>N/A</b>	8. Maximum % Ash: <b>N/A</b>	9. Million Btu per SCC Unit: <b>1,020 HHV</b>
10. Segment Comment:		

**EMISSIONS UNIT INFORMATION**

Section [ 1 ] of [ 10 ]

**E. EMISSIONS UNIT POLLUTANTS**

**List of Pollutants Emitted by Emissions Unit**

1. Pollutant Emitted	2. Primary Control Device Code	3. Secondary Control Device Code	4. Pollutant Regulatory Code
<b>1 - NOX</b>	<b>028</b>	<b>139</b>	<b>EL</b>
<b>2 - CO</b>			<b>EL</b>
<b>3 - VOC</b>			<b>NS</b>
<b>4 - SO2</b>			<b>EL</b>
<b>5 - PM</b>			<b>EL</b>
<b>6 - PM10</b>			<b>EL</b>
<b>7 - SAM</b>			<b>EL</b>
<b>8 - HG</b>			<b>EL</b>
<b>Notes:</b>			
<b>SAM - sulfuric acid mist</b>	<b>028 - water or steam injection</b>	<b>139 - SCR</b>	<b>EL - emissions limited</b>
			<b>NS - no standard</b>

**F1. EMISSIONS UNIT POLLUTANT DETAIL INFORMATION –  
 POTENTIAL, FUGITIVE, AND ACTUAL EMISSIONS**

(Optional for unregulated emissions units.)

**Potential, Estimated Fugitive, and Baseline & Projected Actual Emissions**

Complete for each pollutant identified in Subsection E if applying for an air construction permit or concurrent processing of an air construction permit and a revised or renewal Title V permit. Complete for each emissions-limited pollutant identified in Subsection E if applying for an air operation permit.

1. Pollutant Emitted: <b>NOX</b>		2. Total Percent Efficiency of Control: <b>94%</b>	
3. Potential Emissions: <b>100</b> lb/hour <b>433.6</b> tons/year		4. Synthetically Limited? <input type="checkbox"/> Yes <input checked="" type="checkbox"/> No	
5. Range of Estimated Fugitive Emissions (as applicable): <b>N/A</b> to tons/year			
6. Emission Factor: <b>N/A</b>  Reference: <b>GE Data</b>		7. Emissions Method Code: <b>2</b>	
8.a. Baseline Actual Emissions (if required): <b>N/A</b> tons/year		8.b. Baseline 24-month Period: <b>N/A</b> From:                                      To:	
9.a. Projected Actual Emissions (if required): <b>N/A</b> tons/year		9.b. Projected Monitoring Period: <b>N/A</b> <input type="checkbox"/> 5 years <input type="checkbox"/> 10 years	
10. Calculation of Emissions:  <b>Detailed emission calculations are provided in Appendix A.</b>			
11. Potential, Fugitive, and Actual Emissions Comment:  <b>Potential emissions represent syngas-firing.</b>			

**F2. EMISSIONS UNIT POLLUTANT DETAIL INFORMATION -  
 ALLOWABLE EMISSIONS**

Complete if the pollutant identified in Subsection F1 is or would be subject to a numerical emissions limitation.

**Allowable Emissions** Allowable Emissions  1  of  2

1. Basis for Allowable Emissions Code: <b>RULE (BACT)</b>	2. Future Effective Date of Allowable Emissions: N/A
3. Allowable Emissions and Units: N/A	4. Equivalent Allowable Emissions: 99 lb/hour N/A tons/year
5. Method of Compliance: NO <sub>x</sub> CEMS, 30-day rolling average	
6. Allowable Emissions Comment (Description of Operating Method): Limit applicable to syngas-firing. CT/HRSG No 1. is also subject to the less stringent Subpart Da limit of 1.0 lb/MWh, gross.	

**Allowable Emissions** Allowable Emissions  2  of  2

1. Basis for Allowable Emissions Code: <b>RULE (BACT)</b>	2. Future Effective Date of Allowable Emissions: N/A
3. Allowable Emissions and Units: N/A	4. Equivalent Allowable Emissions: 33 lb/hour N/A tons/year
5. Method of Compliance: NO <sub>x</sub> CEMS, 30-day rolling average	
6. Allowable Emissions Comment (Description of Operating Method): Limit applicable to natural gas-firing. CT/HRSG No 1. is also subject to the less stringent Subpart KKKK limits of 15 ppmvd @15% O <sub>2</sub> , or 0.43 lb/MWh, gross.	

**F1. EMISSIONS UNIT POLLUTANT DETAIL INFORMATION –  
POTENTIAL, FUGITIVE, AND ACTUAL EMISSIONS**

(Optional for unregulated emissions units.)

**Potential, Estimated Fugitive, and Baseline & Projected Actual Emissions**

Complete for each pollutant identified in Subsection E if applying for an air construction permit or concurrent processing of an air construction permit and a revised or renewal Title V permit. Complete for each emissions-limited pollutant identified in Subsection E if applying for an air operation permit.

1. Pollutant Emitted: <b>CO</b>		2. Total Percent Efficiency of Control: <b>N/A</b>	
3. Potential Emissions: <b>94 lb/hour                      407.3 tons/year</b>		4. Synthetically Limited? <input type="checkbox"/> Yes <input checked="" type="checkbox"/> No	
5. Range of Estimated Fugitive Emissions (as applicable): <b>N/A</b> to tons/year			
6. Emission Factor: <b>N/A</b>  Reference: <b>GE Data</b>		7. Emissions Method Code: <b>2</b>	
8.a. Baseline Actual Emissions (if required): <b>N/A tons/year</b>		8.b. Baseline 24-month Period: <b>N/A</b> From:                      To:	
9.a. Projected Actual Emissions (if required): <b>N/A tons/year</b>		9.b. Projected Monitoring Period: <b>N/A</b> <input type="checkbox"/> 5 years <input type="checkbox"/> 10 years	
10. Calculation of Emissions:  <b>Detailed emission calculations are provided in Appendix A.</b>			
11. Potential, Fugitive, and Actual Emissions Comment:  <b>Potential emissions represent syngas-firing.</b>			

**F2. EMISSIONS UNIT POLLUTANT DETAIL INFORMATION -  
 ALLOWABLE EMISSIONS**

**Complete if the pollutant identified in Subsection F1 is or would be subject to a numerical emissions limitation.**

**Allowable Emissions** Allowable Emissions  1  of  2

1. Basis for Allowable Emissions Code: <b>RULE (BACT)</b>	2. Future Effective Date of Allowable Emissions: <b>N/A</b>
3. Allowable Emissions and Units: <b>N/A</b>	4. Equivalent Allowable Emissions: <b>93 lb/hour N/A tons/year</b>
5. Method of Compliance: <b>CO CEMS, 24-hour rolling average</b>	
6. Allowable Emissions Comment (Description of Operating Method):  <b>Limit applicable to syngas-firing.</b>	

**Allowable Emissions** Allowable Emissions  2  of  2

1. Basis for Allowable Emissions Code: <b>RULE (BACT)</b>	2. Future Effective Date of Allowable Emissions: <b>N/A</b>
3. Allowable Emissions and Units: <b>N/A</b>	4. Equivalent Allowable Emissions: <b>81 lb/hour N/A tons/year</b>
5. Method of Compliance: <b>CO CEMS, 24-hour rolling average</b>	
6. Allowable Emissions Comment (Description of Operating Method):  <b>Limit applicable to natural gas-firing.</b>	

F1. EMISSIONS UNIT POLLUTANT DETAIL INFORMATION –  
POTENTIAL, FUGITIVE, AND ACTUAL EMISSIONS

(Optional for unregulated emissions units.)

**Potential, Estimated Fugitive, and Baseline & Projected Actual Emissions**

Complete for each pollutant identified in Subsection E if applying for an air construction permit or concurrent processing of an air construction permit and a revised or renewal Title V permit. Complete for each emissions-limited pollutant identified in Subsection E if applying for an air operation permit.

1. Pollutant Emitted: <b>VOC</b>		2. Total Percent Efficiency of Control: <b>N/A</b>	
3. Potential Emissions: <b>3.3 lb/hour                      14.5 tons/year</b>		4. Synthetically Limited? <input type="checkbox"/> Yes <input checked="" type="checkbox"/> No	
5. Range of Estimated Fugitive Emissions (as applicable): <b>N/A</b> to tons/year			
6. Emission Factor: <b>N/A</b>  Reference: <b>GE Data</b>		7. Emissions Method Code: <b>2</b>	
8.a. Baseline Actual Emissions (if required): <b>N/A tons/year</b>		8.b. Baseline 24-month Period: <b>N/A</b> From:                      To:	
9.a. Projected Actual Emissions (if required): <b>N/A tons/year</b>		9.b. Projected Monitoring Period: <b>N/A</b> <input type="checkbox"/> 5 years <input type="checkbox"/> 10 years	
10. Calculation of Emissions:  <b>Detailed emission calculations are provided in Appendix A.</b>			
11. Potential, Fugitive, and Actual Emissions Comment:  <b>Potential emissions represent syngas-firing.</b>			



**F2. EMISSIONS UNIT POLLUTANT DETAIL INFORMATION -  
 ALLOWABLE EMISSIONS N/A**

**Complete if the pollutant identified in Subsection F1 is or would be subject to a numerical emissions limitation.**

**Allowable Emissions** Allowable Emissions of

1. Basis for Allowable Emissions Code:	2. Future Effective Date of Allowable Emissions:
3. Allowable Emissions and Units:	4. Equivalent Allowable Emissions: Lb/hour                      tons/year
5. Method of Compliance:	
6. Allowable Emissions Comment (Description of Operating Method):	

**Allowable Emissions** Allowable Emissions of

1. Basis for Allowable Emissions Code:	2. Future Effective Date of Allowable Emissions:
3. Allowable Emissions and Units:	4. Equivalent Allowable Emissions: Lb/hour                      tons/year
5. Method of Compliance:	
6. Allowable Emissions Comment (Description of Operating Method):	

**F1. EMISSIONS UNIT POLLUTANT DETAIL INFORMATION –  
POTENTIAL, FUGITIVE, AND ACTUAL EMISSIONS**

(Optional for unregulated emissions units.)

**Potential, Estimated Fugitive, and Baseline & Projected Actual Emissions**

Complete for each pollutant identified in Subsection E if applying for an air construction permit or concurrent processing of an air construction permit and a revised or renewal Title V permit. Complete for each emissions-limited pollutant identified in Subsection E if applying for an air operation permit.

1. Pollutant Emitted: <b>SO2</b>		2. Total Percent Efficiency of Control: <b>N/A</b>	
3. Potential Emissions: <b>54 lb/hour</b> <b>227.8 tons/year</b>		4. Synthetically Limited? <input type="checkbox"/> Yes <input checked="" type="checkbox"/> No	
5. Range of Estimated Fugitive Emissions (as applicable): <b>N/A</b> to tons/year			
6. Emission Factor: <b>N/A</b>  Reference: <b>GE Data</b>		7. Emissions Method Code: <b>2</b>	
8.a. Baseline Actual Emissions (if required): <b>N/A tons/year</b>		8.b. Baseline 24-month Period: <b>N/A</b> From:                      To:	
9.a. Projected Actual Emissions (if required): <b>N/A tons/year</b>		9.b. Projected Monitoring Period: <b>N/A</b> <input type="checkbox"/> 5 years <input type="checkbox"/> 10 years	
10. Calculation of Emissions:  <b>Detailed emission calculations are provided in Appendix A.</b>			
11. Potential, Fugitive, and Actual Emissions Comment:  <b>Potential emissions represent syngas-firing.</b>			

**F2. EMISSIONS UNIT POLLUTANT DETAIL INFORMATION -  
 ALLOWABLE EMISSIONS**

**Complete if the pollutant identified in Subsection F1 is or would be subject to a numerical emissions limitation.**

**Allowable Emissions** Allowable Emissions 1 of 2

1. Basis for Allowable Emissions Code: <b>RULE (BACT)</b>	2. Future Effective Date of Allowable Emissions: N/A
3. Allowable Emissions and Units: N/A	4. Equivalent Allowable Emissions: 52 lb/hour N/A tons/year
5. Method of Compliance: <b>SO<sub>2</sub> CEMS, 30-day rolling average</b>	
6. Allowable Emissions Comment (Description of Operating Method): <b>Limit applicable to syngas-firing. CT/HRSG No 1. is also subject to the less stringent Subpart Da limit of 1.4 lb/MWh, gross.</b>	

**Allowable Emissions** Allowable Emissions 2 of 2

1. Basis for Allowable Emissions Code: <b>RULE (BACT)</b>	2. Future Effective Date of Allowable Emissions: N/A
3. Allowable Emissions and Units: <b>Pipeline Natural Gas</b>	4. Equivalent Allowable Emissions: N/A lb/hour N/A tons/year
5. Method of Compliance: <b>Applicable 40 CFR Part 75 procedures.</b>	
6. Allowable Emissions Comment (Description of Operating Method): <b>Limit applicable to natural gas-firing. CT/HRSG No 1. is also subject to the less stringent Subpart KKKK limits of 0.060 lb/MMBtu or 0.90 lb/MWh, gross.</b>	

**F1. EMISSIONS UNIT POLLUTANT DETAIL INFORMATION –  
POTENTIAL, FUGITIVE, AND ACTUAL EMISSIONS**

(Optional for unregulated emissions units.)

**Potential, Estimated Fugitive, and Baseline & Projected Actual Emissions**

Complete for each pollutant identified in Subsection E if applying for an air construction permit or concurrent processing of an air construction permit and a revised or renewal Title V permit. Complete for each emissions-limited pollutant identified in Subsection E if applying for an air operation permit.

1. Pollutant Emitted: <b>PM/PM10</b>		2. Total Percent Efficiency of Control: <b>N/A</b>	
3. Potential Emissions: <b>39 lb/hour</b> <b>170.8 tons/year</b>		4. Synthetically Limited? <input type="checkbox"/> Yes <input checked="" type="checkbox"/> No	
5. Range of Estimated Fugitive Emissions (as applicable): <b>N/A</b> to tons/year			
6. Emission Factor: <b>N/A</b>  Reference: <b>GE Data</b>		7. Emissions Method Code: <b>2</b>	
8.a. Baseline Actual Emissions (if required): <b>N/A tons/year</b>		8.b. Baseline 24-month Period: <b>N/A</b> From:                      To:	
9.a. Projected Actual Emissions (if required): <b>N/A tons/year</b>		9.b. Projected Monitoring Period: <b>N/A</b> <input type="checkbox"/> 5 years <input type="checkbox"/> 10 years	
10. Calculation of Emissions:  <b>Detailed emission calculations are provided in Appendix A.</b>			
11. Potential, Fugitive, and Actual Emissions Comment:  <b>Potential emissions represent syngas-firing.</b>			

**F2. EMISSIONS UNIT POLLUTANT DETAIL INFORMATION -  
ALLOWABLE EMISSIONS**

Complete if the pollutant identified in Subsection F1 is or would be subject to a numerical emissions limitation.

**Allowable Emissions** Allowable Emissions  1  of  2

1. Basis for Allowable Emissions Code: <b>RULE (BACT)</b>	2. Future Effective Date of Allowable Emissions: <b>N/A</b>
3. Allowable Emissions and Units: <b>N/A</b>	4. Equivalent Allowable Emissions: <b>39 lb/hour                      N/A tons/year</b>
5. Method of Compliance: <b>EPA Reference Methods 201 or 201A, and 202.</b>	
6. Allowable Emissions Comment (Description of Operating Method): <b>Limit applicable to syngas-firing. CT/HRSG No 1. is also subject to the less stringent Subpart Da limits of 0.14 lb/MWh, gross or 0.015 lb/MMBtu.</b>	

**Allowable Emissions** Allowable Emissions  2  of  2

1. Basis for Allowable Emissions Code: <b>RULE (BACT)</b>	2. Future Effective Date of Allowable Emissions: <b>N/A</b>
3. Allowable Emissions and Units: <b>Pipeline Natural Gas</b>	4. Equivalent Allowable Emissions: <b>N/A lb/hour                      N/A tons/year</b>
5. Method of Compliance: <b>Applicable 40 CFR Part 75 procedures.</b>	
6. Allowable Emissions Comment (Description of Operating Method):  <b>Limit applicable to natural gas-firing.</b>	

**F1. EMISSIONS UNIT POLLUTANT DETAIL INFORMATION –  
POTENTIAL, FUGITIVE, AND ACTUAL EMISSIONS**

(Optional for unregulated emissions units.)

**Potential, Estimated Fugitive, and Baseline & Projected Actual Emissions**

Complete for each pollutant identified in Subsection E if applying for an air construction permit or concurrent processing of an air construction permit and a revised or renewal Title V permit. Complete for each emissions-limited pollutant identified in Subsection E if applying for an air operation permit.

1. Pollutant Emitted: <b>SAM</b>		2. Total Percent Efficiency of Control: <b>N/A</b>	
3. Potential Emissions: <b>12.8 lb/hour</b> <b>53.4 tons/year</b>		4. Synthetically Limited? <input type="checkbox"/> Yes <input checked="" type="checkbox"/> No	
5. Range of Estimated Fugitive Emissions (as applicable): <b>N/A</b> to tons/year			
6. Emission Factor: <b>N/A</b>  Reference: <b>GE Data</b>		7. Emissions Method Code: <b>2</b>	
8.a. Baseline Actual Emissions (if required): <b>N/A tons/year</b>		8.b. Baseline 24-month Period: <b>N/A</b> From:                      To:	
9.a. Projected Actual Emissions (if required): <b>N/A tons/year</b>		9.b. Projected Monitoring Period: <b>N/A</b> <input type="checkbox"/> 5 years <input type="checkbox"/> 10 years	
10. Calculation of Emissions:  <b>Detailed emission calculations are provided in Appendix A.</b>			
11. Potential, Fugitive, and Actual Emissions Comment:  <b>Potential emissions represent syngas-firing.</b>			

**F2. EMISSIONS UNIT POLLUTANT DETAIL INFORMATION -  
 ALLOWABLE EMISSIONS**

**Complete if the pollutant identified in Subsection F1 is or would be subject to a numerical emissions limitation.**

**Allowable Emissions** Allowable Emissions 1 of 2

1. Basis for Allowable Emissions Code: <b>RULE (BACT)</b>	2. Future Effective Date of Allowable Emissions: N/A
3. Allowable Emissions and Units: N/A	4. Equivalent Allowable Emissions: <b>12.8 lb/hour</b> N/A tons/year
5. Method of Compliance: <b>EPA Reference Method 8 or NCASI Method 8A.</b>	
6. Allowable Emissions Comment (Description of Operating Method):  <b>Limit applicable to syngas-firing.</b>	

**Allowable Emissions** Allowable Emissions 2 of 2

1. Basis for Allowable Emissions Code: <b>RULE (BACT)</b>	2. Future Effective Date of Allowable Emissions: N/A
3. Allowable Emissions and Units: <b>Pipeline Natural Gas</b>	4. Equivalent Allowable Emissions: N/A lb/hour N/A tons/year
5. Method of Compliance: <b>Applicable 40 CFR Part 75 procedures.</b>	
6. Allowable Emissions Comment (Description of Operating Method):  <b>Limit applicable to natural gas-firing.</b>	

**F1. EMISSIONS UNIT POLLUTANT DETAIL INFORMATION –  
 POTENTIAL, FUGITIVE, AND ACTUAL EMISSIONS**

(Optional for unregulated emissions units.)

**Potential, Estimated Fugitive, and Baseline & Projected Actual Emissions**

Complete for each pollutant identified in Subsection E if applying for an air construction permit or concurrent processing of an air construction permit and a revised or renewal Title V permit. Complete for each emissions-limited pollutant identified in Subsection E if applying for an air operation permit.

1. Pollutant Emitted: <b>HG</b>		2. Total Percent Efficiency of Control: <b>N/A</b>	
3. Potential Emissions: <b>0.0032 lb/hour      0.013 tons/year</b>		4. Synthetically Limited? <input type="checkbox"/> Yes <input checked="" type="checkbox"/> No	
5. Range of Estimated Fugitive Emissions (as applicable): <b>N/A</b> to tons/year			
6. Emission Factor: <b>1.0 lb / 10<sup>12</sup> Btu</b>  Reference: <b>TEC Data</b>		7. Emissions Method Code: <b>2</b>	
8.a. Baseline Actual Emissions (if required): <b>N/A tons/year</b>		8.b. Baseline 24-month Period: <b>N/A</b> From:                      To:	
9.a. Projected Actual Emissions (if required): <b>N/A tons/year</b>		9.b. Projected Monitoring Period: <b>N/A</b> <input type="checkbox"/> 5 years <input type="checkbox"/> 10 years	
10. Calculation of Emissions:  <b>Detailed emission calculations are provided in Appendix A.</b>			
11. Potential, Fugitive, and Actual Emissions Comment:			



**F2. EMISSIONS UNIT POLLUTANT DETAIL INFORMATION -  
 ALLOWABLE EMISSIONS**

Complete if the pollutant identified in Subsection F1 is or would be subject to a numerical emissions limitation.

**Allowable Emissions** Allowable Emissions  1  of  2

1. Basis for Allowable Emissions Code: <b>RULE (NSPS Subpart Da)</b>	2. Future Effective Date of Allowable Emissions: N/A
3. Allowable Emissions and Units: <b>20 x 10<sup>-6</sup> lb / MWh</b>	4. Equivalent Allowable Emissions: N/A lb/hour <b>0.035 tons/year</b>
5. Method of Compliance: <b>Applicable 40 CFR Part 60 Subpart Da procedures, 12-month rolling average.</b>	
6. Allowable Emissions Comment (Description of Operating Method):  <b>Limit applicable to syngas-firing.</b>	

**Allowable Emissions** Allowable Emissions  2  of  2

1. Basis for Allowable Emissions Code: <b>OTHER</b>	2. Future Effective Date of Allowable Emissions: N/A
3. Allowable Emissions and Units: <b>7.5 x 10<sup>-6</sup> lb / MWh</b>	4. Equivalent Allowable Emissions: N/A lb/hour <b>0.013 tons/year</b>
5. Method of Compliance: <b>Applicable 40 CFR Part 60 Subpart Da procedures, 12-month rolling average.</b>	
6. Allowable Emissions Comment (Description of Operating Method):  <b>Limit applicable to syngas-firing. Voluntary limit.</b>	

**EMISSIONS UNIT INFORMATION**

Section [ 1 ] of [ 10 ]

**G. VISIBLE EMISSIONS INFORMATION**

Complete if this emissions unit is or would be subject to a unit-specific visible emissions limitation.

**Visible Emissions Limitation:** Visible Emissions Limitation 1 of 1

1. Visible Emissions Subtype: <b>VE20</b>	2. Basis for Allowable Opacity: <input checked="" type="checkbox"/> Rule <input type="checkbox"/> Other
3. Allowable Opacity: Normal Conditions: <b>20 %</b> Exceptional Conditions: % Maximum Period of Excess Opacity Allowed: min/hour	
4. Method of Compliance: <b>EPA Reference Method 9</b>	
5. Visible Emissions Comment:  <b>Rule 62-296.320(4)(b), F.A.C. NSPS Subpart Da.</b>	

**Visible Emissions Limitation:** Visible Emissions Limitation \_\_\_ of \_\_\_

1. Visible Emissions Subtype:	2. Basis for Allowable Opacity: <input type="checkbox"/> Rule <input type="checkbox"/> Other
3. Allowable Opacity: Normal Conditions: % Exceptional Conditions: % Maximum Period of Excess Opacity Allowed: min/hour	
4. Method of Compliance:	
5. Visible Emissions Comment	

**EMISSIONS UNIT INFORMATION**

Section [ 1 ] of [ 10 ]

**H. CONTINUOUS MONITOR INFORMATION**

Complete if this emissions unit is or would be subject to continuous monitoring.

**Continuous Monitoring System:** Continuous Monitor 1 of 4

1. Parameter Code: <b>EM</b>	2. Pollutant(s): <b>NO<sub>x</sub></b>
3. CMS Requirement: <input checked="" type="checkbox"/> Rule <input type="checkbox"/> Other	
4. Monitor Information Manufacturer: Model Number: Serial Number:	
5. Installation Date:	6. Performance Specification Test Date:
7. Continuous Monitor Comment:  <b>Required by 40 CFR Part 75 (Acid Rain Program). Specific CEMS information will be provided to FDEP when available.</b>	

**Continuous Monitoring System:** Continuous Monitor 2 of 4

1. Parameter Code: <b>O<sub>2</sub> or CO<sub>2</sub></b>	2. Pollutant(s):
3. CMS Requirement: <input checked="" type="checkbox"/> Rule <input type="checkbox"/> Other	
4. Monitor Information Manufacturer: Model Number: Serial Number:	
5. Installation Date:	6. Performance Specification Test Date:
7. Continuous Monitor Comment:  <b>NO<sub>x</sub> diluent CEM requirements of 40 CFR Part 75 (Acid Rain Program). Specific CEMS information will be provided to FDEP when available.</b>	

**EMISSIONS UNIT INFORMATION**

Section [ 1 ] of [ 10 ]

**H. CONTINUOUS MONITOR INFORMATION**

Complete if this emissions unit is or would be subject to continuous monitoring.

**Continuous Monitoring System:** Continuous Monitor 3 of 4

1. Parameter Code: <b>EM</b>	2. Pollutant(s): <b>Hg</b>
3. CMS Requirement: <input checked="" type="checkbox"/> Rule <input type="checkbox"/> Other	
4. Monitor Information Manufacturer: Model Number: Serial Number:	
5. Installation Date:	6. Performance Specification Test Date:
7. Continuous Monitor Comment:  <b>Required by 40 CFR Part 60, Subpart Da. Specific CEMS information will be provided to FDEP when available.</b>	

**Continuous Monitoring System:** Continuous Monitor 4 of 4

1. Parameter Code: <b>EM</b>	2. Pollutant(s): <b>CO</b>
3. CMS Requirement: <input type="checkbox"/> Rule <input checked="" type="checkbox"/> Other	
4. Monitor Information Manufacturer: Model Number: Serial Number:	
5. Installation Date:	6. Performance Specification Test Date:
7. Continuous Monitor Comment:  <b>Specific CEMS information will be provided to FDEP when available.</b>	

**EMISSIONS UNIT INFORMATION**

Section [ 1 ] of [ 10 ]

**I. EMISSIONS UNIT ADDITIONAL INFORMATION**

**Additional Requirements for All Applications, Except as Otherwise Stated**

1. Process Flow Diagram (Required for all permit applications, except Title V air operation permit revision applications if this information was submitted to the department within the previous five years and would not be altered as a result of the revision being sought) <input checked="" type="checkbox"/> Attached, Document ID: <u>Fig. 2-4</u> <input type="checkbox"/> Previously Submitted, Date _____
2. Fuel Analysis or Specification (Required for all permit applications, except Title V air operation permit revision applications if this information was submitted to the department within the previous five years and would not be altered as a result of the revision being sought) <input checked="" type="checkbox"/> Attached, Document ID: <u>Section 2.2, Tables 2-2 and 2-4</u>
3. Detailed Description of Control Equipment (Required for all permit applications, except Title V air operation permit revision applications if this information was submitted to the department within the previous five years and would not be altered as a result of the revision being sought) <input checked="" type="checkbox"/> Attached, Document ID: <u>Section 2.0</u> <input type="checkbox"/> Previously Submitted, Date _____
4. Procedures for Startup and Shutdown (Required for all operation permit applications, except Title V air operation permit revision applications if this information was submitted to the department within the previous five years and would not be altered as a result of the revision being sought) <input checked="" type="checkbox"/> Not Applicable (construction application)
5. Operation and Maintenance Plan (Required for all permit applications, except Title V air operation permit revision applications if this information was submitted to the department within the previous five years and would not be altered as a result of the revision being sought) <input type="checkbox"/> Attached, Document ID: _____ <input type="checkbox"/> Previously Submitted, Date _____ <input checked="" type="checkbox"/> Not Applicable
6. Compliance Demonstration Reports/Records <input type="checkbox"/> Attached, Document ID: _____ Test Date(s)/Pollutant(s) Tested: _____ _____ <input type="checkbox"/> Previously Submitted, Date: _____ Test Date(s)/Pollutant(s) Tested: _____ _____ <input type="checkbox"/> To be Submitted, Date (if known): _____ Test Date(s)/Pollutant(s) Tested: _____ _____ <input checked="" type="checkbox"/> Not Applicable  Note: For FESOP applications, all required compliance demonstration records/reports must be submitted at the time of application. For Title V air operation permit applications, all required compliance demonstration reports/records must be submitted at the time of application, or a compliance plan must be submitted at the time of application.
7. Other Information Required by Rule or Statute <input type="checkbox"/> Attached, Document ID: _____ <input checked="" type="checkbox"/> Not Applicable

**EMISSIONS UNIT INFORMATION**

Section [ 1 ] of [ 10 ]

**Additional Requirements for Air Construction Permit Applications**

1. Control Technology Review and Analysis (Rules 62-212.400(10) and 62-212.500(7), F.A.C.; 40 CFR 63.43(d) and (e)) <input checked="" type="checkbox"/> Attached, Document ID: <u>Section 5.0</u> <input type="checkbox"/> Not Applicable
2. Good Engineering Practice Stack Height Analysis (Rule 62-212.400(4)(d), F.A.C., and Rule 62-212.500(4)(f), F.A.C.) <input checked="" type="checkbox"/> Attached, Document ID: <u>Section 6.0</u> <input type="checkbox"/> Not Applicable
3. Description of Stack Sampling Facilities (Required for proposed new stack sampling facilities only) <b>To be provided to FDEP when available.</b> <input type="checkbox"/> Attached, Document ID: _____ <input type="checkbox"/> Not Applicable

**Additional Requirements for Title V Air Operation Permit Applications** **NOT APPLICABLE**

1. Identification of Applicable Requirements <input type="checkbox"/> Attached, Document ID: _____
2. Compliance Assurance Monitoring <input type="checkbox"/> Attached, Document ID: _____ <input type="checkbox"/> Not Applicable
3. Alternative Methods of Operation <input type="checkbox"/> Attached, Document ID: _____ <input type="checkbox"/> Not Applicable
4. Alternative Modes of Operation (Emissions Trading) <input type="checkbox"/> Attached, Document ID: _____ <input type="checkbox"/> Not Applicable
5. Acid Rain Part Application <input type="checkbox"/> Certificate of Representation (EPA Form No. 7610-1) <input type="checkbox"/> Copy Attached, Document ID: _____ <input type="checkbox"/> Acid Rain Part (Form No. 62-210.900(1)(a)) <input type="checkbox"/> Attached, Document ID: _____ <input type="checkbox"/> Previously Submitted, Date: _____ <input type="checkbox"/> Repowering Extension Plan (Form No. 62-210.900(1)(a)1.) <input type="checkbox"/> Attached, Document ID: _____ <input type="checkbox"/> Previously Submitted, Date: _____ <input type="checkbox"/> New Unit Exemption (Form No. 62-210.900(1)(a)2.) <input type="checkbox"/> Attached, Document ID: _____ <input type="checkbox"/> Previously Submitted, Date: _____ <input type="checkbox"/> Retired Unit Exemption (Form No. 62-210.900(1)(a)3.) <input type="checkbox"/> Attached, Document ID: _____ <input type="checkbox"/> Previously Submitted, Date: _____ <input type="checkbox"/> Phase II NOx Compliance Plan (Form No. 62-210.900(1)(a)4.) <input type="checkbox"/> Attached, Document ID: _____ <input type="checkbox"/> Previously Submitted, Date: _____ <input type="checkbox"/> Phase II NOx Averaging Plan (Form No. 62-210.900(1)(a)5.) <input type="checkbox"/> Attached, Document ID: _____ <input type="checkbox"/> Previously Submitted, Date: _____ <input type="checkbox"/> Not Applicable

**EMISSIONS UNIT INFORMATION**

**Section [ 1 ] of [ 10 ]**

**Additional Requirements Comment**

**EMISSIONS UNIT INFORMATION**

Section | 2 | of | 10 |

**A. GENERAL EMISSIONS UNIT INFORMATION**

**Title V Air Operation Permit Emissions Unit Classification**

1. Regulated or Unregulated Emissions Unit? (Check one, if applying for an initial, revised or renewal Title V air operation permit. Skip this item if applying for an air construction permit or FESOP only.) N/A

- The emissions unit addressed in this Emissions Unit Information Section is a regulated emissions unit.
- The emissions unit addressed in this Emissions Unit Information Section is an unregulated emissions unit.

**Emissions Unit Description and Status**

1. Type of Emissions Unit Addressed in this Section: (Check one)

- This Emissions Unit Information Section addresses, as a single emissions unit, a single process or production unit, or activity, which produces one or more air pollutants and which has at least one definable emission point (stack or vent).
- This Emissions Unit Information Section addresses, as a single emissions unit, a group of process or production units and activities which has at least one definable emission point (stack or vent) but may also produce fugitive emissions.
- This Emissions Unit Information Section addresses, as a single emissions unit, one or more process or production units and activities which produce fugitive emissions only.

2. Description of Emissions Unit Addressed in this Section:

**GE 7FB combustion turbine (CT) and unfired recovery steam generator (HRSG). The CT may be fired with either syngas or pipeline natural gas. CT/HRSG No. 2 shares a common steam turbine with CT/HRSG No. 1.**

3. Emissions Unit Identification Number: **012 (Unit 6 CT/HRSG No. 2)**

4. Emissions Unit Status Code: <b>C</b>	5. Commence Construction Date: <b>N/A</b>	6. Initial Startup Date: <b>N/A</b>	7. Emissions Unit Major Group SIC Code: <b>49</b>	8. Acid Rain Unit? <input checked="" type="checkbox"/> Yes <input type="checkbox"/> No
--	--	--	--	--

9. Package Unit:  
Manufacturer:

Model Number:

10. Generator Nameplate Rating: **790-MW, gross 630-MW, net (nominal)**

11. Emissions Unit Comment:

**Generator nameplate ratings are total nominal generation capacities for Unit 6 CT/HRSG No. 1, CT/HRSG No. 2, and common steam turbine.**



**EMISSIONS UNIT INFORMATION**

**Section | 2 | of | 10 |**

**Emissions Unit Control Equipment**

1. Control Equipment/Method(s) Description:

**Syngas**

**NO<sub>x</sub> – Nitrogen Diluent**

– Syngas Moisturization

– Selective Catalytic Reduction (SCR) [139]

**Natural Gas**

**NO<sub>x</sub> – Wet Injection [028]**

– Selective Catalytic Reduction (SCR) [139]

2. Control Device or Method Code(s): **Syngas (139), Natural Gas (028, 139)**

**EMISSIONS UNIT INFORMATION**

Section | 2 | of | 10 |

**B. EMISSIONS UNIT CAPACITY INFORMATION**

(Optional for unregulated emissions units.)

**Emissions Unit Operating Capacity and Schedule**

1. Maximum Process or Throughput Rate: N/A
2. Maximum Production Rate: N/A
3. Maximum Heat Input Rate: <b>3,200</b> million Btu/hr, <b>HHV</b>
4. Maximum Incineration Rate: <b>N/A</b> pounds/hr tons/day
5. Requested Maximum Operating Schedule: 24 hours/day 7 days/week 52 weeks/year 8,760 hours/year
6. Operating Capacity/Schedule Comment:  <b>Maximum heat input shown above is the Train No. 2 gasifier heat input at 100% load and 0°F ambient temperature, on a higher heating value basis (HHV).</b>  <b>Maximum CT heat input for the Unit 6 CT/HRSG No. 2 during natural gas-firing is 1,980 x 10<sup>6</sup> Btu/hr at 100% load and 0°F ambient temperature, HHV basis.</b>

**EMISSIONS UNIT INFORMATION**  
**Section [ 2 ] of [ 10 ]**

**C. EMISSION POINT (STACK/VENT) INFORMATION**  
**(Optional for unregulated emissions units.)**

**Emission Point Description and Type**

1. Identification of Point on Plot Plan or Flow Diagram: <b>Unit 6 CT/HRSG No. 2</b>		2. Emission Point Type Code: <b>1</b>	
3. Descriptions of Emission Points Comprising this Emissions Unit for VE Tracking:  <b>N/A</b>			
4. ID Numbers or Descriptions of Emission Units with this Emission Point in Common:  <b>N/A</b>			
5. Discharge Type Code: <b>V</b>	6. Stack Height: <b>175 feet</b>	7. Exit Diameter: <b>18.6 feet</b>	
8. Exit Temperature: <b>275 °F</b>	9. Actual Volumetric Flow Rate: <b>1,298,566 acfm</b>	10. Water Vapor: <b>N/A %</b>	
11. Maximum Dry Standard Flow Rate: <b>N/A dscfm</b>		12. Nonstack Emission Point Height: <b>N/A feet</b>	
13. Emission Point UTM Coordinates Zone: <b>17</b> East (km): <b>402.53</b> North (km): <b>3,066.75</b>		14. Emission Point Latitude/Longitude <b>N/A</b> Latitude (DD/MM/SS) <b>N/A</b> Longitude (DD/MM/SS)	
15. Emission Point Comment:  <b>Exit temperature (Field 8) and volumetric flow rate (Field 9) for are syngas Operating Case No. 4 – 100% load and 59°F ambient temperature.</b>			

**EMISSIONS UNIT INFORMATION**

Section [ 2 ] of [ 10 ]

**D. SEGMENT (PROCESS/FUEL) INFORMATION**

**Segment Description and Rate: Segment 1 of 2**

1. Segment Description (Process/Fuel Type):  <b>Combustion turbine fired with coal-derived syngas.</b>		
2. Source Classification Code (SCC): <b>1-01-019-01</b>		3. SCC Units: <b>Million Cubic Feet Burned</b>
4. Maximum Hourly Rate: <b>10.44</b>	5. Maximum Annual Rate: <b>91,454.4</b>	6. Estimated Annual Activity Factor: <b>N/A</b>
7. Maximum % Sulfur: <b>&lt;0.1</b>	8. Maximum % Ash: <b>N/A</b>	9. Million Btu per SCC Unit: <b>246, HHV</b>
10. Segment Comment:		

**Segment Description and Rate: Segment 2 of 2**

1. Segment Description (Process/Fuel Type):  <b>Combustion turbine fired with pipeline natural gas.</b>		
2. Source Classification Code (SCC): <b>2-01-002-01</b>		3. SCC Units: <b>Million Cubic Feet Burned</b>
4. Maximum Hourly Rate: <b>1.94</b>	5. Maximum Annual Rate: <b>16,994.4</b>	6. Estimated Annual Activity Factor: <b>N/A</b>
7. Maximum % Sulfur: <b>N/A</b>	8. Maximum % Ash: <b>N/A</b>	9. Million Btu per SCC Unit: <b>1,020 HHV</b>
10. Segment Comment:		

**EMISSIONS UNIT INFORMATION**

Section [ 2 ] of [ 10 ]

**E. EMISSIONS UNIT POLLUTANTS**

**List of Pollutants Emitted by Emissions Unit**

1. Pollutant Emitted	2. Primary Control Device Code	3. Secondary Control Device Code	4. Pollutant Regulatory Code
<b>1 - NOX</b>	<b>028</b>	<b>139</b>	<b>EL</b>
<b>2 - CO</b>			<b>EL</b>
<b>3 - VOC</b>			<b>NS</b>
<b>4 - SO2</b>			<b>EL</b>
<b>5 - PM</b>			<b>EL</b>
<b>6 - PM10</b>			<b>EL</b>
<b>7 - SAM</b>			<b>EL</b>
<b>8 - HG</b>			<b>EL</b>
<b>Notes:</b> <b>SAM - sulfuric acid mist</b>	<b>028 - water or steam injection</b>	<b>139 - SCR</b>	<b>EL - emissions limited</b>
			<b>NS - no standard</b>

**F1. EMISSIONS UNIT POLLUTANT DETAIL INFORMATION –  
 POTENTIAL, FUGITIVE, AND ACTUAL EMISSIONS**

(Optional for unregulated emissions units.)

**Potential, Estimated Fugitive, and Baseline & Projected Actual Emissions**

Complete for each pollutant identified in Subsection E if applying for an air construction permit or concurrent processing of an air construction permit and a revised or renewal Title V permit. Complete for each emissions-limited pollutant identified in Subsection E if applying for an air operation permit.

1. Pollutant Emitted: <b>NOX</b>	2. Total Percent Efficiency of Control: <b>94%</b>
3. Potential Emissions: <b>100 lb/hour 433.6 tons/year</b>	4. Synthetically Limited? <input type="checkbox"/> Yes <input checked="checked" type="checkbox"/> No
5. Range of Estimated Fugitive Emissions (as applicable): <b>N/A</b> to tons/year	
6. Emission Factor: <b>N/A</b>  Reference: <b>GE Data</b>	7. Emissions Method Code: <b>2</b>
8.a. Baseline Actual Emissions (if required): <b>N/A tons/year</b>	8.b. Baseline 24-month Period: <b>N/A</b> From: To:
9.a. Projected Actual Emissions (if required): <b>N/A tons/year</b>	9.b. Projected Monitoring Period: <b>N/A</b> <input type="checkbox"/> 5 years <input type="checkbox"/> 10 years
10. Calculation of Emissions:  <b>Detailed emission calculations are provided in Appendix A.</b>	
11. Potential, Fugitive, and Actual Emissions Comment:  <b>Potential emissions represent syngas-firing.</b>	

**F2. EMISSIONS UNIT POLLUTANT DETAIL INFORMATION -  
 ALLOWABLE EMISSIONS**

Complete if the pollutant identified in Subsection F1 is or would be subject to a numerical emissions limitation.

**Allowable Emissions** Allowable Emissions  1  of  2

1. Basis for Allowable Emissions Code: <b>RULE (BACT)</b>	2. Future Effective Date of Allowable Emissions: N/A
3. Allowable Emissions and Units: N/A	4. Equivalent Allowable Emissions: <b>99 lb/hour</b> N/A tons/year
5. Method of Compliance: <b>NO<sub>x</sub> CEMS, 30-day rolling average</b>	
6. Allowable Emissions Comment (Description of Operating Method): <b>Limit applicable to syngas-firing. CT/HRSG No 2. is also subject to the less stringent Subpart Da limit of 1.0 lb/MWh, gross.</b>	

**Allowable Emissions** Allowable Emissions  2  of  2

1. Basis for Allowable Emissions Code: <b>RULE (BACT)</b>	2. Future Effective Date of Allowable Emissions: N/A
3. Allowable Emissions and Units: N/A	4. Equivalent Allowable Emissions: <b>33 lb/hour</b> N/A tons/year
5. Method of Compliance: <b>NO<sub>x</sub> CEMS, 30-day rolling average</b>	
6. Allowable Emissions Comment (Description of Operating Method): <b>Limit applicable to natural gas-firing. CT/HRSG No 2. is also subject to the less stringent Subpart KKKK limits of 15 ppmvd @15% O<sub>2</sub>, or 0.43 lb/MWh, gross.</b>	

F1. EMISSIONS UNIT POLLUTANT DETAIL INFORMATION –  
 POTENTIAL, FUGITIVE, AND ACTUAL EMISSIONS

(Optional for unregulated emissions units.)

**Potential, Estimated Fugitive, and Baseline & Projected Actual Emissions**

Complete for each pollutant identified in Subsection E if applying for an air construction permit or concurrent processing of an air construction permit and a revised or renewal Title V permit. Complete for each emissions-limited pollutant identified in Subsection E if applying for an air operation permit.

1. Pollutant Emitted: <b>CO</b>		2. Total Percent Efficiency of Control: <b>N/A</b>	
3. Potential Emissions: <b>94 lb/hour</b> <b>407.3 tons/year</b>		4. Synthetically Limited? <input type="checkbox"/> Yes <input checked="" type="checkbox"/> No	
5. Range of Estimated Fugitive Emissions (as applicable): <b>N/A</b> to tons/year			
6. Emission Factor: <b>N/A</b>  Reference: <b>GE Data</b>		7. Emissions Method Code: <b>2</b>	
8.a. Baseline Actual Emissions (if required): <b>N/A tons/year</b>		8.b. Baseline 24-month Period: <b>N/A</b> From:                      To:	
9.a. Projected Actual Emissions (if required): <b>N/A tons/year</b>		9.b. Projected Monitoring Period: <b>N/A</b> <input type="checkbox"/> 5 years <input type="checkbox"/> 10 years	
10. Calculation of Emissions:  <b>Detailed emission calculations are provided in Appendix A.</b>			
11. Potential, Fugitive, and Actual Emissions Comment:  <b>Potential emissions represent syngas-firing.</b>			



**F2. EMISSIONS UNIT POLLUTANT DETAIL INFORMATION -  
ALLOWABLE EMISSIONS**

Complete if the pollutant identified in Subsection F1 is or would be subject to a numerical emissions limitation.

**Allowable Emissions** Allowable Emissions 1 of 2

1. Basis for Allowable Emissions Code: <b>RULE (BACT)</b>	2. Future Effective Date of Allowable Emissions: <b>N/A</b>
3. Allowable Emissions and Units: <b>N/A</b>	4. Equivalent Allowable Emissions: <b>93 lb/hour N/A tons/year</b>
5. Method of Compliance: <b>CO CEMS, 24-hour rolling average</b>	
6. Allowable Emissions Comment (Description of Operating Method):  <b>Limit applicable to syngas-firing.</b>	

**Allowable Emissions** Allowable Emissions 2 of 2

1. Basis for Allowable Emissions Code: <b>RULE (BACT)</b>	2. Future Effective Date of Allowable Emissions: <b>N/A</b>
3. Allowable Emissions and Units: <b>N/A</b>	4. Equivalent Allowable Emissions: <b>81 lb/hour N/A tons/year</b>
5. Method of Compliance: <b>CO CEMS, 24-hour rolling average</b>	
6. Allowable Emissions Comment (Description of Operating Method):  <b>Limit applicable to natural gas-firing.</b>	

**F1. EMISSIONS UNIT POLLUTANT DETAIL INFORMATION –  
 POTENTIAL, FUGITIVE, AND ACTUAL EMISSIONS**

(Optional for unregulated emissions units.)

**Potential, Estimated Fugitive, and Baseline & Projected Actual Emissions**

**Complete for each pollutant identified in Subsection E if applying for an air construction permit or concurrent processing of an air construction permit and a revised or renewal Title V permit. Complete for each emissions-limited pollutant identified in Subsection E if applying for an air operation permit.**

1. Pollutant Emitted: <b>VOC</b>		2. Total Percent Efficiency of Control: <b>N/A</b>	
3. Potential Emissions: <b>3.3 lb/hour                      14.5 tons/year</b>		4. Synthetically Limited? <input type="checkbox"/> Yes <input checked="" type="checkbox"/> No	
5. Range of Estimated Fugitive Emissions (as applicable): <b>N/A</b> to tons/year			
6. Emission Factor: <b>N/A</b>  Reference: <b>GE Data</b>		7. Emissions Method Code: <b>2</b>	
8.a. Baseline Actual Emissions (if required): <b>N/A tons/year</b>		8.b. Baseline 24-month Period: <b>N/A</b> From:                      To:	
9.a. Projected Actual Emissions (if required): <b>N/A tons/year</b>		9.b. Projected Monitoring Period: <b>N/A</b> <input type="checkbox"/> 5 years <input type="checkbox"/> 10 years	
10. Calculation of Emissions:  <b>Detailed emission calculations are provided in Appendix A.</b>			
11. Potential, Fugitive, and Actual Emissions Comment:  <b>Potential emissions represent syngas-firing.</b>			

**F2. EMISSIONS UNIT POLLUTANT DETAIL INFORMATION -  
 ALLOWABLE EMISSIONS N/A**

**Complete if the pollutant identified in Subsection F1 is or would be subject to a numerical emissions limitation.**

**Allowable Emissions** Allowable Emissions of

1. Basis for Allowable Emissions Code:	2. Future Effective Date of Allowable Emissions:
3. Allowable Emissions and Units:	4. Equivalent Allowable Emissions: Lb/hour                      tons/year
5. Method of Compliance:	
6. Allowable Emissions Comment (Description of Operating Method):	

**Allowable Emissions** Allowable Emissions of

1. Basis for Allowable Emissions Code:	2. Future Effective Date of Allowable Emissions:
3. Allowable Emissions and Units:	4. Equivalent Allowable Emissions: Lb/hour                      tons/year
5. Method of Compliance:	
6. Allowable Emissions Comment (Description of Operating Method):	

**F1. EMISSIONS UNIT POLLUTANT DETAIL INFORMATION –  
 POTENTIAL, FUGITIVE, AND ACTUAL EMISSIONS**

(Optional for unregulated emissions units.)

**Potential, Estimated Fugitive, and Baseline & Projected Actual Emissions**

Complete for each pollutant identified in Subsection E if applying for an air construction permit or concurrent processing of an air construction permit and a revised or renewal Title V permit. Complete for each emissions-limited pollutant identified in Subsection E if applying for an air operation permit.

1. Pollutant Emitted: <b>SO2</b>		2. Total Percent Efficiency of Control: <b>N/A</b>	
3. Potential Emissions: <b>54 lb/hour</b> <b>227.8 tons/year</b>		4. Synthetically Limited? <input type="checkbox"/> Yes <input checked="" type="checkbox"/> No	
5. Range of Estimated Fugitive Emissions (as applicable): <b>N/A</b> to tons/year			
6. Emission Factor: <b>N/A</b>  Reference: <b>GE Data</b>		7. Emissions Method Code: <b>2</b>	
8.a. Baseline Actual Emissions (if required): <b>N/A tons/year</b>		8.b. Baseline 24-month Period: <b>N/A</b> From:                      To:	
9.a. Projected Actual Emissions (if required): <b>N/A tons/year</b>		9.b. Projected Monitoring Period: <b>N/A</b> <input type="checkbox"/> 5 years <input type="checkbox"/> 10 years	
10. Calculation of Emissions:  <b>Detailed emission calculations are provided in Appendix A.</b>			
11. Potential, Fugitive, and Actual Emissions Comment:  <b>Potential emissions represent syngas-firing.</b>			

**F2. EMISSIONS UNIT POLLUTANT DETAIL INFORMATION -  
 ALLOWABLE EMISSIONS**

Complete if the pollutant identified in Subsection F1 is or would be subject to a numerical emissions limitation.

**Allowable Emissions** Allowable Emissions  1  of  2

1. Basis for Allowable Emissions Code: <b>RULE (BACT)</b>	2. Future Effective Date of Allowable Emissions: <b>N/A</b>
3. Allowable Emissions and Units: <b>N/A</b>	4. Equivalent Allowable Emissions: <b>52 lb/hour                      N/A tons/year</b>
5. Method of Compliance: <b>SO<sub>2</sub> CEMS, 30-day rolling average</b>	
6. Allowable Emissions Comment (Description of Operating Method): <b>Limit applicable to syngas-firing. CT/HRSG No 2. is also subject to the less stringent Subpart Da limit of 1.4 lb/MWh, gross.</b>	

**Allowable Emissions** Allowable Emissions  2  of  2

1. Basis for Allowable Emissions Code: <b>RULE (BACT)</b>	2. Future Effective Date of Allowable Emissions: <b>N/A</b>
3. Allowable Emissions and Units: <b>Pipeline Natural Gas</b>	4. Equivalent Allowable Emissions: <b>N/A lb/hour                      N/A tons/year</b>
5. Method of Compliance: <b>Applicable 40 CFR Part 75 procedures.</b>	
6. Allowable Emissions Comment (Description of Operating Method): <b>Limit applicable to natural gas-firing. CT/HRSG No 2. is also subject to the less stringent Subpart KKKK limits of 0.060 lb/MMBtu or 0.90 lb/MWh, gross.</b>	

**F1. EMISSIONS UNIT POLLUTANT DETAIL INFORMATION –  
 POTENTIAL, FUGITIVE, AND ACTUAL EMISSIONS**

(Optional for unregulated emissions units.)

**Potential, Estimated Fugitive, and Baseline & Projected Actual Emissions**

Complete for each pollutant identified in Subsection E if applying for an air construction permit or concurrent processing of an air construction permit and a revised or renewal Title V permit. Complete for each emissions-limited pollutant identified in Subsection E if applying for an air operation permit.

1. Pollutant Emitted: <b>PM/PM10</b>		2. Total Percent Efficiency of Control: <b>N/A</b>	
3. Potential Emissions: <b>39 lb/hour</b> <b>170.8 tons/year</b>		4. Synthetically Limited? <input type="checkbox"/> Yes <input checked="" type="checkbox"/> No	
5. Range of Estimated Fugitive Emissions (as applicable): <b>N/A</b> to tons/year			
6. Emission Factor: <b>N/A</b>  Reference: <b>GE Data</b>		7. Emissions Method Code: <b>2</b>	
8.a. Baseline Actual Emissions (if required): <b>N/A tons/year</b>		8.b. Baseline 24-month Period: <b>N/A</b> From:                      To:	
9.a. Projected Actual Emissions (if required): <b>N/A tons/year</b>		9.b. Projected Monitoring Period: <b>N/A</b> <input type="checkbox"/> 5 years <input type="checkbox"/> 10 years	
10. Calculation of Emissions:  <b>Detailed emission calculations are provided in Appendix A.</b>			
11. Potential, Fugitive, and Actual Emissions Comment:  <b>Potential emissions represent syngas-firing.</b>			

**F2. EMISSIONS UNIT POLLUTANT DETAIL INFORMATION -  
 ALLOWABLE EMISSIONS**

Complete if the pollutant identified in Subsection F1 is or would be subject to a numerical emissions limitation.

**Allowable Emissions** Allowable Emissions  1  of  2

1. Basis for Allowable Emissions Code: <b>RULE (BACT)</b>	2. Future Effective Date of Allowable Emissions: N/A
3. Allowable Emissions and Units: N/A	4. Equivalent Allowable Emissions: 39 lb/hour      N/A tons/year
5. Method of Compliance: <b>EPA Reference Methods 201 or 201A, and 202.</b>	
6. Allowable Emissions Comment (Description of Operating Method): <b>Limit applicable to syngas-firing. CT/HRSG No 2. is also subject to the less stringent Subpart Da limits of 0.14 lb/MWh, gross or 0.015 lb/MMBtu.</b>	

**Allowable Emissions** Allowable Emissions  2  of  2

1. Basis for Allowable Emissions Code: <b>RULE (BACT)</b>	2. Future Effective Date of Allowable Emissions: N/A
3. Allowable Emissions and Units: <b>Pipeline Natural Gas</b>	4. Equivalent Allowable Emissions: N/A lb/hour      N/A tons/year
5. Method of Compliance: <b>Applicable 40 CFR Part 75 procedures.</b>	
6. Allowable Emissions Comment (Description of Operating Method):  <b>Limit applicable to natural gas-firing.</b>	

**F1. EMISSIONS UNIT POLLUTANT DETAIL INFORMATION –  
 POTENTIAL, FUGITIVE, AND ACTUAL EMISSIONS**

(Optional for unregulated emissions units.)

**Potential, Estimated Fugitive, and Baseline & Projected Actual Emissions**

Complete for each pollutant identified in Subsection E if applying for an air construction permit or concurrent processing of an air construction permit and a revised or renewal Title V permit. Complete for each emissions-limited pollutant identified in Subsection E if applying for an air operation permit.

1. Pollutant Emitted: <b>SAM</b>		2. Total Percent Efficiency of Control: <b>N/A</b>	
3. Potential Emissions: <b>12.8 lb/hour                      53.4 tons/year</b>		4. Synthetically Limited? <input type="checkbox"/> Yes <input checked="" type="checkbox"/> No	
5. Range of Estimated Fugitive Emissions (as applicable): <b>N/A</b> to tons/year			
6. Emission Factor: <b>N/A</b>  Reference: <b>GE Data</b>		7. Emissions Method Code: <b>2</b>	
8.a. Baseline Actual Emissions (if required): <b>N/A tons/year</b>		8.b. Baseline 24-month Period: <b>N/A</b> From:                      To:	
9.a. Projected Actual Emissions (if required): <b>N/A tons/year</b>		9.b. Projected Monitoring Period: <b>N/A</b> <input type="checkbox"/> 5 years <input type="checkbox"/> 10 years	
10. Calculation of Emissions:  <b>Detailed emission calculations are provided in Appendix A.</b>			
11. Potential, Fugitive, and Actual Emissions Comment:  <b>Potential emissions represent syngas-firing.</b>			



**F2. EMISSIONS UNIT POLLUTANT DETAIL INFORMATION -  
 ALLOWABLE EMISSIONS**

Complete if the pollutant identified in Subsection F1 is or would be subject to a numerical emissions limitation.

**Allowable Emissions** Allowable Emissions  1  of  2

1. Basis for Allowable Emissions Code: <b>RULE (BACT)</b>	2. Future Effective Date of Allowable Emissions: N/A
3. Allowable Emissions and Units: N/A	4. Equivalent Allowable Emissions: 12.8 lb/hour      N/A tons/year
5. Method of Compliance: <b>EPA Reference Method 8 or NCASI Method 8A.</b>	
6. Allowable Emissions Comment (Description of Operating Method):  <b>Limit applicable to syngas-firing.</b>	

**Allowable Emissions** Allowable Emissions  2  of  2

1. Basis for Allowable Emissions Code: <b>RULE (BACT)</b>	2. Future Effective Date of Allowable Emissions: N/A
3. Allowable Emissions and Units: <b>Pipeline Natural Gas</b>	4. Equivalent Allowable Emissions: N/A lb/hour      N/A tons/year
5. Method of Compliance: <b>Applicable 40 CFR Part 75 procedures.</b>	
6. Allowable Emissions Comment (Description of Operating Method):  <b>Limit applicable to natural gas-firing.</b>	

**F1. EMISSIONS UNIT POLLUTANT DETAIL INFORMATION –  
 POTENTIAL, FUGITIVE, AND ACTUAL EMISSIONS**

(Optional for unregulated emissions units.)

**Potential, Estimated Fugitive, and Baseline & Projected Actual Emissions**

Complete for each pollutant identified in Subsection E if applying for an air construction permit or concurrent processing of an air construction permit and a revised or renewal Title V permit. Complete for each emissions-limited pollutant identified in Subsection E if applying for an air operation permit.

1. Pollutant Emitted: <b>HG</b>		2. Total Percent Efficiency of Control: <b>N/A</b>	
3. Potential Emissions: <b>0.0032 lb/hour      0.013 tons/year</b>		4. Synthetically Limited? <input type="checkbox"/> Yes <input checked="" type="checkbox"/> No	
5. Range of Estimated Fugitive Emissions (as applicable): <b>N/A</b> to tons/year			
6. Emission Factor: <b>1.0 lb / 10<sup>12</sup> Btu</b> Reference: <b>TEC Data</b>		7. Emissions Method Code: <b>2</b>	
8.a. Baseline Actual Emissions (if required): <b>N/A tons/year</b>		8.b. Baseline 24-month Period: <b>N/A</b> From:                                 To:	
9.a. Projected Actual Emissions (if required): <b>N/A tons/year</b>		9.b. Projected Monitoring Period: <b>N/A</b> <input type="checkbox"/> 5 years <input type="checkbox"/> 10 years	
10. Calculation of Emissions:  <b>Detailed emission calculations are provided in Appendix A.</b>			
11. Potential, Fugitive, and Actual Emissions Comment:			

**F2. EMISSIONS UNIT POLLUTANT DETAIL INFORMATION -  
 ALLOWABLE EMISSIONS**

Complete if the pollutant identified in Subsection F1 is or would be subject to a numerical emissions limitation.

**Allowable Emissions** Allowable Emissions  1  of  2

1. Basis for Allowable Emissions Code: <b>RULE (NSPS Subpart Da)</b>	2. Future Effective Date of Allowable Emissions: N/A
3. Allowable Emissions and Units: <b>20 x 10<sup>-6</sup> lb / MWh</b>	4. Equivalent Allowable Emissions: N/A lb/hour <b>0.035 tons/year</b>
5. Method of Compliance: <b>Applicable 40 CFR Part 60 Subpart Da procedures, 12-month rolling average.</b>	
6. Allowable Emissions Comment (Description of Operating Method):  <b>Limit applicable to syngas-firing.</b>	

**Allowable Emissions** Allowable Emissions  2  of  2

1. Basis for Allowable Emissions Code: <b>OTHER</b>	2. Future Effective Date of Allowable Emissions: N/A
3. Allowable Emissions and Units: <b>7.5 x 10<sup>-6</sup> lb / MWh</b>	4. Equivalent Allowable Emissions: N/A lb/hour <b>0.013 tons/year</b>
5. Method of Compliance: <b>Applicable 40 CFR Part 60 Subpart Da procedures, 12-month rolling average.</b>	
6. Allowable Emissions Comment (Description of Operating Method):  <b>Limit applicable to syngas-firing. Voluntary limit.</b>	

**EMISSIONS UNIT INFORMATION**

Section [ 2 ] of [ 10 ]

**G. VISIBLE EMISSIONS INFORMATION**

Complete if this emissions unit is or would be subject to a unit-specific visible emissions limitation.

**Visible Emissions Limitation:** Visible Emissions Limitation 1 of 1

1. Visible Emissions Subtype: <b>VE20</b>	2. Basis for Allowable Opacity: <input checked="" type="checkbox"/> Rule <input type="checkbox"/> Other
3. Allowable Opacity: Normal Conditions: <b>20 %</b> Exceptional Conditions: % Maximum Period of Excess Opacity Allowed: min/hour	
4. Method of Compliance: <b>EPA Reference Method 9</b>	
5. Visible Emissions Comment:  <b>Rule 62-296.320(4)(b), F.A.C. NSPS Subpart Da.</b>	

**Visible Emissions Limitation:** Visible Emissions Limitation \_\_\_ of \_\_\_

1. Visible Emissions Subtype:	2. Basis for Allowable Opacity: <input type="checkbox"/> Rule <input type="checkbox"/> Other
3. Allowable Opacity: Normal Conditions: % Exceptional Conditions: % Maximum Period of Excess Opacity Allowed: min/hour	
4. Method of Compliance:	
5. Visible Emissions Comment	

**EMISSIONS UNIT INFORMATION**

Section [ 2 ] of [ 10 ]

**H. CONTINUOUS MONITOR INFORMATION**

Complete if this emissions unit is or would be subject to continuous monitoring.

**Continuous Monitoring System:** Continuous Monitor 1 of 4

1. Parameter Code: <b>EM</b>	2. Pollutant(s): <b>NO<sub>x</sub></b>
3. CMS Requirement:	<input checked="" type="checkbox"/> Rule <input type="checkbox"/> Other
4. Monitor Information Manufacturer: Model Number:	Serial Number:
5. Installation Date:	6. Performance Specification Test Date:
7. Continuous Monitor Comment:  <b>Required by 40 CFR Part 75 (Acid Rain Program). Specific CEMS information will be provided to FDEP when available.</b>	

**Continuous Monitoring System:** Continuous Monitor 2 of 4

1. Parameter Code: <b>O<sub>2</sub> or CO<sub>2</sub></b>	2. Pollutant(s):
3. CMS Requirement:	<input checked="" type="checkbox"/> Rule <input type="checkbox"/> Other
4. Monitor Information Manufacturer: Model Number:	Serial Number:
5. Installation Date:	6. Performance Specification Test Date:
7. Continuous Monitor Comment:  <b>NO<sub>x</sub> diluent CEM requirements of 40 CFR Part 75 (Acid Rain Program). Specific CEMS information will be provided to FDEP when available.</b>	

**EMISSIONS UNIT INFORMATION**

Section [ 2 ] of [ 10 ]

**H. CONTINUOUS MONITOR INFORMATION**

Complete if this emissions unit is or would be subject to continuous monitoring.

**Continuous Monitoring System:** Continuous Monitor 3 of 4

1. Parameter Code: <b>EM</b>	2. Pollutant(s): <b>Hg</b>
3. CMS Requirement: <input checked="" type="checkbox"/> Rule <input type="checkbox"/> Other	
4. Monitor Information Manufacturer: Model Number: <span style="float: right;">Serial Number:</span>	
5. Installation Date:	6. Performance Specification Test Date:
7. Continuous Monitor Comment:  <b>Required by 40 CFR Part 60, Subpart Da. Specific CEMS information will be provided to FDEP when available.</b>	

**Continuous Monitoring System:** Continuous Monitor 4 of 4

1. Parameter Code: <b>EM</b>	2. Pollutant(s): <b>CO</b>
3. CMS Requirement: <input type="checkbox"/> Rule <input checked="" type="checkbox"/> Other	
4. Monitor Information Manufacturer: Model Number: <span style="float: right;">Serial Number:</span>	
5. Installation Date:	6. Performance Specification Test Date:
7. Continuous Monitor Comment:  <b>Specific CEMS information will be provided to FDEP when available.</b>	

**EMISSIONS UNIT INFORMATION**

Section [ 2 ] of [ 10 ]

**I. EMISSIONS UNIT ADDITIONAL INFORMATION**

**Additional Requirements for All Applications, Except as Otherwise Stated**

1. Process Flow Diagram (Required for all permit applications, except Title V air operation permit revision applications if this information was submitted to the department within the previous five years and would not be altered as a result of the revision being sought) <input checked="" type="checkbox"/> Attached, Document ID: <u>Fig. 2-4</u> <input type="checkbox"/> Previously Submitted, Date _____
2. Fuel Analysis or Specification (Required for all permit applications, except Title V air operation permit revision applications if this information was submitted to the department within the previous five years and would not be altered as a result of the revision being sought) <input checked="" type="checkbox"/> Attached, Document ID: <u>Section 2.2, Tables 2-2 and 2-4</u>
3. Detailed Description of Control Equipment (Required for all permit applications, except Title V air operation permit revision applications if this information was submitted to the department within the previous five years and would not be altered as a result of the revision being sought) <input checked="" type="checkbox"/> Attached, Document ID: <u>Section 2.0</u> <input type="checkbox"/> Previously Submitted, Date _____
4. Procedures for Startup and Shutdown (Required for all operation permit applications, except Title V air operation permit revision applications if this information was submitted to the department within the previous five years and would not be altered as a result of the revision being sought) <input checked="" type="checkbox"/> Not Applicable (construction application)
5. Operation and Maintenance Plan (Required for all permit applications, except Title V air operation permit revision applications if this information was submitted to the department within the previous five years and would not be altered as a result of the revision being sought) <input type="checkbox"/> Attached, Document ID: _____ <input type="checkbox"/> Previously Submitted, Date _____ <input checked="" type="checkbox"/> Not Applicable
6. Compliance Demonstration Reports/Records <input type="checkbox"/> Attached, Document ID: _____ Test Date(s)/Pollutant(s) Tested: _____ <input type="checkbox"/> Previously Submitted, Date: _____ Test Date(s)/Pollutant(s) Tested: _____ <input type="checkbox"/> To be Submitted, Date (if known): _____ Test Date(s)/Pollutant(s) Tested: _____ <input checked="" type="checkbox"/> Not Applicable  Note: For FESOP applications, all required compliance demonstration records/reports must be submitted at the time of application. For Title V air operation permit applications, all required compliance demonstration reports/records must be submitted at the time of application, or a compliance plan must be submitted at the time of application.
7. Other Information Required by Rule or Statute <input type="checkbox"/> Attached, Document ID: _____ <input checked="" type="checkbox"/> Not Applicable

**EMISSIONS UNIT INFORMATION**

Section | 2 | of | 10 |

**Additional Requirements for Air Construction Permit Applications**

1. Control Technology Review and Analysis (Rules 62-212.400(10) and 62-212.500(7), F.A.C.; 40 CFR 63.43(d) and (e)) <input checked="" type="checkbox"/> Attached, Document ID: <u>Section 5.0</u> <input type="checkbox"/> Not Applicable
2. Good Engineering Practice Stack Height Analysis (Rule 62-212.400(4)(d), F.A.C., and Rule 62-212.500(4)(f), F.A.C.) <input checked="" type="checkbox"/> Attached, Document ID: <u>Section 6.0</u> <input type="checkbox"/> Not Applicable
3. Description of Stack Sampling Facilities (Required for proposed new stack sampling facilities only) <b>To be provided to FDEP when available.</b> <input type="checkbox"/> Attached, Document ID: _____ <input type="checkbox"/> Not Applicable

**Additional Requirements for Title V Air Operation Permit Applications** **NOT APPLICABLE**

1. Identification of Applicable Requirements <input type="checkbox"/> Attached, Document ID: _____
2. Compliance Assurance Monitoring <input type="checkbox"/> Attached, Document ID: _____ <input type="checkbox"/> Not Applicable
3. Alternative Methods of Operation <input type="checkbox"/> Attached, Document ID: _____ <input type="checkbox"/> Not Applicable
4. Alternative Modes of Operation (Emissions Trading) <input type="checkbox"/> Attached, Document ID: _____ <input type="checkbox"/> Not Applicable
5. Acid Rain Part Application <input type="checkbox"/> Certificate of Representation (EPA Form No. 7610-1) <input type="checkbox"/> Copy Attached, Document ID: _____ <input type="checkbox"/> Acid Rain Part (Form No. 62-210.900(1)(a)) <input type="checkbox"/> Attached, Document ID: _____ <input type="checkbox"/> Previously Submitted, Date: _____ <input type="checkbox"/> Repowering Extension Plan (Form No. 62-210.900(1)(a)1.) <input type="checkbox"/> Attached, Document ID: _____ <input type="checkbox"/> Previously Submitted, Date: _____ <input type="checkbox"/> New Unit Exemption (Form No. 62-210.900(1)(a)2.) <input type="checkbox"/> Attached, Document ID: _____ <input type="checkbox"/> Previously Submitted, Date: _____ <input type="checkbox"/> Retired Unit Exemption (Form No. 62-210.900(1)(a)3.) <input type="checkbox"/> Attached, Document ID: _____ <input type="checkbox"/> Previously Submitted, Date: _____ <input type="checkbox"/> Phase II NOx Compliance Plan (Form No. 62-210.900(1)(a)4.) <input type="checkbox"/> Attached, Document ID: _____ <input type="checkbox"/> Previously Submitted, Date: _____ <input type="checkbox"/> Phase II NOx Averaging Plan (Form No. 62-210.900(1)(a)5.) <input type="checkbox"/> Attached, Document ID: _____ <input type="checkbox"/> Previously Submitted, Date: _____ <input type="checkbox"/> Not Applicable



**EMISSIONS UNIT INFORMATION**

Section | 2 | of | 10 |

**Additional Requirements Comment**

**EMISSIONS UNIT INFORMATION**

Section [ 3 ] of [ 10 ]

**A. GENERAL EMISSIONS UNIT INFORMATION**

**Title V Air Operation Permit Emissions Unit Classification**

1. Regulated or Unregulated Emissions Unit? (Check one, if applying for an initial, revised or renewal Title V air operation permit. Skip this item if applying for an air construction permit or FESOP only.)

- The emissions unit addressed in this Emissions Unit Information Section is a regulated emissions unit.
- The emissions unit addressed in this Emissions Unit Information Section is an unregulated emissions unit.

**Emissions Unit Description and Status**

1. Type of Emissions Unit Addressed in this Section: (Check one)

- This Emissions Unit Information Section addresses, as a single emissions unit, a single process or production unit, or activity, which produces one or more air pollutants and which has at least one definable emission point (stack or vent).
- This Emissions Unit Information Section addresses, as a single emissions unit, a group of process or production units and activities which has at least one definable emission point (stack or vent) but may also produce fugitive emissions.
- This Emissions Unit Information Section addresses, as a single emissions unit, one or more process or production units and activities which produce fugitive emissions only.

2. Description of Emissions Unit Addressed in this Section:

**Auxiliary team boiler fired with pipeline natural gas.**

3. Emissions Unit Identification Number: **013 (Auxiliary Boiler)**

4. Emissions Unit Status Code: <b>C</b>	5. Commence Construction Date: <b>N/A</b>	6. Initial Startup Date: <b>N/A</b>	7. Emissions Unit Major Group SIC Code: <b>49</b>	8. Acid Rain Unit? <input type="checkbox"/> Yes <input checked="" type="checkbox"/> No
--	--	--	--	--

9. Package Unit:

Manufacturer:

Model Number:

10. Generator Nameplate Rating: **MW**

11. Emissions Unit Comment:

**EMISSIONS UNIT INFORMATION**

Section [ 3 ] of [ 10 ]

**Emissions Unit Control Equipment**

1. Control Equipment/Method(s) Description:

**NO<sub>x</sub> and CO**

**Low NO<sub>x</sub> Burners (LNB [Control Device Code 205]**

**PM, PM<sub>10</sub>, SO<sub>2</sub>, and H<sub>2</sub>SO<sub>4</sub> Mist**

**Pipeline Natural Gas**

2. Control Device or Method Code(s): **205**

**EMISSIONS UNIT INFORMATION**

Section [ 3 ] of [ 10 ]

**B. EMISSIONS UNIT CAPACITY INFORMATION**

(Optional for unregulated emissions units.)

**Emissions Unit Operating Capacity and Schedule**

1. Maximum Process or Throughput Rate: N/A
2. Maximum Production Rate: N/A
3. Maximum Heat Input Rate: <b>300</b> million Btu/hr, <b>HHV</b>
4. Maximum Incineration Rate: N/A pounds/hr tons/day
5. Requested Maximum Operating Schedule: hours/day days/week weeks/year <b>876</b> hours/year
6. Operating Capacity/Schedule Comment:

**EMISSIONS UNIT INFORMATION**

Section [ 3 ] of [ 10 ]

**C. EMISSION POINT (STACK/VENT) INFORMATION**  
 (Optional for unregulated emissions units.)

**Emission Point Description and Type**

1. Identification of Point on Plot Plan or Flow Diagram: <b>Auxiliary Boiler</b>		2. Emission Point Type Code: <b>1</b>	
3. Descriptions of Emission Points Comprising this Emissions Unit for VE Tracking:  <b>N/A</b>			
4. ID Numbers or Descriptions of Emission Units with this Emission Point in Common:  <b>N/A</b>			
5. Discharge Type Code: <b>V</b>	6. Stack Height: <b>100</b> feet	7. Exit Diameter: <b>5.0</b> feet	
8. Exit Temperature: <b>500°F</b>	9. Actual Volumetric Flow Rate: <b>70,686</b> acfm	10. Water Vapor: <b>N/A</b> %	
11. Maximum Dry Standard Flow Rate: <b>N/A</b> dscfm		12. Nonstack Emission Point Height: <b>N/A</b> feet	
13. Emission Point UTM Coordinates Zone: <b>17</b> East (km): <b>402.52</b> North (km): <b>3,066.99</b>		14. Emission Point Latitude/Longitude <b>N/A</b> Latitude (DD/MM/SS) <b>N/A</b> Longitude (DD/MM/SS)	
15. Emission Point Comment:			

**EMISSIONS UNIT INFORMATION**

Section [ 3 ] of [ 10 ]

**D. SEGMENT (PROCESS/FUEL) INFORMATION**

**Segment Description and Rate:** Segment 1 of 1

1. Segment Description (Process/Fuel Type):  <b>Pipeline natural gas combusted in an industrial boiler.</b>		
2. Source Classification Code (SCC): <b>1-02-006-01</b>		3. SCC Units: <b>Million Cubic Feet Burned</b>
4. Maximum Hourly Rate: <b>0.29</b>	5. Maximum Annual Rate: <b>257.6</b>	6. Estimated Annual Activity Factor: <b>N/A</b>
7. Maximum % Sulfur: <b>N/A</b>	8. Maximum % Ash: <b>N/A</b>	9. Million Btu per SCC Unit: <b>1,020 HHV</b>
10. Segment Comment:		

**Segment Description and Rate:** Segment of

1. Segment Description (Process/Fuel Type):		
2. Source Classification Code (SCC):		3. SCC Units:
4. Maximum Hourly Rate:	5. Maximum Annual Rate:	6. Estimated Annual Activity Factor:
7. Maximum % Sulfur:	8. Maximum % Ash:	9. Million Btu per SCC Unit:
10. Segment Comment:		

**EMISSIONS UNIT INFORMATION**

Section [ 3 ] of [ 10 ]

**E. EMISSIONS UNIT POLLUTANTS**

**List of Pollutants Emitted by Emissions Unit**

1. Pollutant Emitted	2. Primary Control Device Code	3. Secondary Control Device Code	4. Pollutant Regulatory Code
1 - NOX	205		EL
2 - SO2			EL
3 - PM			EL
4 - PM10			EL
5 - CO	205		EL
6 - VOC			NS
7 - SAM			EL

**F1. EMISSIONS UNIT POLLUTANT DETAIL INFORMATION –  
POTENTIAL, FUGITIVE, AND ACTUAL EMISSIONS**

(Optional for unregulated emissions units.)

**Potential, Estimated Fugitive, and Baseline & Projected Actual Emissions**

Complete for each pollutant identified in Subsection E if applying for an air construction permit or concurrent processing of an air construction permit and a revised or renewal Title V permit. Complete for each emissions-limited pollutant identified in Subsection E if applying for an air operation permit.

1. Pollutant Emitted: <b>NOX</b>		2. Total Percent Efficiency of Control:	
3. Potential Emissions: <b>10.8 lb/hour</b> <b>4.7 tons/year</b>		4. Synthetically Limited? <input checked="" type="checkbox"/> Yes <input type="checkbox"/> No	
5. Range of Estimated Fugitive Emissions (as applicable): <b>N/A</b> to tons/year			
6. Emission Factor: <b>0.036 lb/MMBtu</b>  Reference: <b>TEC, 2007.</b>		7. Emissions Method Code: <b>5</b>	
8.a. Baseline Actual Emissions (if required): <b>N/A tons/year</b>		8.b. Baseline 24-month Period: <b>N/A</b> From:                      To:	
9.a. Projected Actual Emissions (if required): <b>N/A tons/year</b>		9.b. Projected Monitoring Period: <b>N/A</b> <input type="checkbox"/> 5 years <input type="checkbox"/> 10 years	
10. Calculation of Emissions:  <b>Detailed emission calculations are provided in Appendix A.</b>			
11. Potential, Fugitive, and Actual Emissions Comment:  <b>Auxiliary boiler will have a maximum capacity factor of 10%; i.e., 876 hours per year at design capacity.</b>			



**F2. EMISSIONS UNIT POLLUTANT DETAIL INFORMATION -  
ALLOWABLE EMISSIONS**

**Complete if the pollutant identified in Subsection F1 is or would be subject to a numerical emissions limitation.**

**Allowable Emissions** Allowable Emissions **1** of **1**

1. Basis for Allowable Emissions Code: <b>RULE (BACT)</b>	2. Future Effective Date of Allowable Emissions: <b>N/A</b>
3. Allowable Emissions and Units: <b>N/A</b>	4. Equivalent Allowable Emissions: <b>10.8 lb/hour      N/A tons/year</b>
5. Method of Compliance: <b>Stack Test – EPA Reference Method 7E.</b>	
6. Allowable Emissions Comment (Description of Operating Method):  <b>Rule 62-212.400(4)(c), F.A.C.</b>	

**Allowable Emissions** Allowable Emissions of

1. Basis for Allowable Emissions Code:	2. Future Effective Date of Allowable Emissions:
3. Allowable Emissions and Units:	4. Equivalent Allowable Emissions: <b>lb/hour      tons/year</b>
5. Method of Compliance:	
6. Allowable Emissions Comment (Description of Operating Method):	

**Allowable Emissions** Allowable Emissions of

1. Basis for Allowable Emissions Code:	2. Future Effective Date of Allowable Emissions:
3. Allowable Emissions and Units:	4. Equivalent Allowable Emissions: <b>lb/hour      tons/year</b>
5. Method of Compliance:	
6. Allowable Emissions Comment (Description of Operating Method):	

**F1. EMISSIONS UNIT POLLUTANT DETAIL INFORMATION –  
POTENTIAL, FUGITIVE, AND ACTUAL EMISSIONS**

(Optional for unregulated emissions units.)

**Potential, Estimated Fugitive, and Baseline & Projected Actual Emissions**

Complete for each pollutant identified in Subsection E if applying for an air construction permit or concurrent processing of an air construction permit and a revised or renewal Title V permit. Complete for each emissions-limited pollutant identified in Subsection E if applying for an air operation permit.

1. Pollutant Emitted: <b>SO2</b>		2. Total Percent Efficiency of Control:	
3. Potential Emissions: <b>1.8 lb/hour</b> <b>0.8 tons/year</b>		4. Synthetically Limited? <input checked="" type="checkbox"/> Yes <input type="checkbox"/> No	
5. Range of Estimated Fugitive Emissions (as applicable): <b>N/A</b> to tons/year			
6. Emission Factor: <b>0.0059 lb/MMBtu</b>  Reference: <b>ECT, 2007.</b>		7. Emissions Method Code: <b>2</b>	
8.a. Baseline Actual Emissions (if required): <b>N/A tons/year</b>		8.b. Baseline 24-month Period: <b>N/A</b> From:                      To:	
9.a. Projected Actual Emissions (if required): <b>N/A tons/year</b>		9.b. Projected Monitoring Period: <b>N/A</b> <input type="checkbox"/> 5 years <input type="checkbox"/> 10 years	
10. Calculation of Emissions:  <b>Detailed emission calculations are provided in Appendix A.</b>			
11. Potential, Fugitive, and Actual Emissions Comment:  <b>Auxiliary boiler will have a maximum capacity factor of 10%; i.e., 876 hours per year at design capacity.</b>			

**F2. EMISSIONS UNIT POLLUTANT DETAIL INFORMATION -  
 ALLOWABLE EMISSIONS**

**Complete if the pollutant identified in Subsection F1 is or would be subject to a numerical emissions limitation.**

**Allowable Emissions** Allowable Emissions **1** of **1**

1. Basis for Allowable Emissions Code: <b>RULE (BACT)</b>	2. Future Effective Date of Allowable Emissions: <b>N/A</b>
3. Allowable Emissions and Units: <b>Pipeline Natural Gas</b>	4. Equivalent Allowable Emissions: <b>N/A lb/hour      N/A tons/year</b>
5. Method of Compliance: <b>Natural gas analysis for sulfur content.</b>	
6. Allowable Emissions Comment (Description of Operating Method):  <b>Rule 62-212.400(4)(c), F.A.C.</b>	

**Allowable Emissions** Allowable Emissions of

1. Basis for Allowable Emissions Code:	2. Future Effective Date of Allowable Emissions:
3. Allowable Emissions and Units:	4. Equivalent Allowable Emissions: <b>lb/hour      tons/year</b>
5. Method of Compliance:	
6. Allowable Emissions Comment (Description of Operating Method):	

**Allowable Emissions** Allowable Emissions of

1. Basis for Allowable Emissions Code:	2. Future Effective Date of Allowable Emissions:
3. Allowable Emissions and Units:	4. Equivalent Allowable Emissions: <b>lb/hour      tons/year</b>
5. Method of Compliance:	
6. Allowable Emissions Comment (Description of Operating Method):	

**F1. EMISSIONS UNIT POLLUTANT DETAIL INFORMATION –  
POTENTIAL, FUGITIVE, AND ACTUAL EMISSIONS**

(Optional for unregulated emissions units.)

**Potential, Estimated Fugitive, and Baseline & Projected Actual Emissions**

Complete for each pollutant identified in Subsection E if applying for an air construction permit or concurrent processing of an air construction permit and a revised or renewal Title V permit. Complete for each emissions-limited pollutant identified in Subsection E if applying for an air operation permit.

1. Pollutant Emitted: <b>PM/PM10</b>		2. Total Percent Efficiency of Control:	
3. Potential Emissions: <b>2.2 lb/hour</b> <b>1.0 tons/year</b>		4. Synthetically Limited? <input checked="" type="checkbox"/> Yes <input type="checkbox"/> No	
5. Range of Estimated Fugitive Emissions (as applicable): <b>N/A</b> to tons/year			
6. Emission Factor: <b>0.007 lb/MMBtu</b>  Reference: <b>AP-42.</b>		7. Emissions Method Code: <b>3</b>	
8.a. Baseline Actual Emissions (if required): <b>N/A tons/year</b>		8.b. Baseline 24-month Period: <b>N/A</b> From:                      To:	
9.a. Projected Actual Emissions (if required): <b>N/A tons/year</b>		9.b. Projected Monitoring Period: <b>N/A</b> <input type="checkbox"/> 5 years <input type="checkbox"/> 10 years	
10. Calculation of Emissions:  <b>Detailed emission calculations are provided in Appendix A.</b>			
11. Potential, Fugitive, and Actual Emissions Comment:  <b>Auxiliary boiler will have a maximum capacity factor of 10%; i.e., 876 hours per year at design capacity.</b>			

**F2. EMISSIONS UNIT POLLUTANT DETAIL INFORMATION -  
 ALLOWABLE EMISSIONS**

**Complete if the pollutant identified in Subsection F1 is or would be subject to a numerical emissions limitation.**

**Allowable Emissions** Allowable Emissions 1 of 1

1. Basis for Allowable Emissions Code: <b>RULE (BACT)</b>	2. Future Effective Date of Allowable Emissions: <b>N/A</b>
3. Allowable Emissions and Units: <b>Pipeline Natural Gas</b>	4. Equivalent Allowable Emissions: <b>N/A lb/hour      N/A tons/year</b>
5. Method of Compliance: <b>Natural gas analysis for sulfur content.</b>	
6. Allowable Emissions Comment (Description of Operating Method):  <b>Rule 62-212.400(4)(c), F.A.C.</b>	

**Allowable Emissions** Allowable Emissions of

1. Basis for Allowable Emissions Code:	2. Future Effective Date of Allowable Emissions:
3. Allowable Emissions and Units:	4. Equivalent Allowable Emissions: <b>lb/hour      tons/year</b>
5. Method of Compliance:	
6. Allowable Emissions Comment (Description of Operating Method):	

**Allowable Emissions** Allowable Emissions of

1. Basis for Allowable Emissions Code:	2. Future Effective Date of Allowable Emissions:
3. Allowable Emissions and Units:	4. Equivalent Allowable Emissions: <b>lb/hour      tons/year</b>
5. Method of Compliance:	
6. Allowable Emissions Comment (Description of Operating Method):	

**F1. EMISSIONS UNIT POLLUTANT DETAIL INFORMATION –  
POTENTIAL, FUGITIVE, AND ACTUAL EMISSIONS**

(Optional for unregulated emissions units.)

**Potential, Estimated Fugitive, and Baseline & Projected Actual Emissions**

Complete for each pollutant identified in Subsection E if applying for an air construction permit or concurrent processing of an air construction permit and a revised or renewal Title V permit. Complete for each emissions-limited pollutant identified in Subsection E if applying for an air operation permit.

1. Pollutant Emitted: <b>CO</b>		2. Total Percent Efficiency of Control:	
3. Potential Emissions: <b>10.8 lb/hour</b> <b>4.7 tons/year</b>		4. Synthetically Limited? <input checked="" type="checkbox"/> Yes <input type="checkbox"/> No	
5. Range of Estimated Fugitive Emissions (as applicable): <b>N/A</b> to tons/year			
6. Emission Factor: <b>0.036 lb/MMBtu</b>  Reference: <b>TEC, 2007.</b>		7. Emissions Method Code: <b>5</b>	
8.a. Baseline Actual Emissions (if required): <b>N/A tons/year</b>		8.b. Baseline 24-month Period: <b>N/A</b> From:                      To:	
9.a. Projected Actual Emissions (if required): <b>N/A tons/year</b>		9.b. Projected Monitoring Period: <b>N/A</b> <input type="checkbox"/> 5 years <input type="checkbox"/> 10 years	
10. Calculation of Emissions:  <b>Detailed emission calculations are provided in Appendix A.</b>			
11. Potential, Fugitive, and Actual Emissions Comment:  <b>Auxiliary boiler will have a maximum capacity factor of 10%; i.e., 876 hours per year at design capacity.</b>			

**F2. EMISSIONS UNIT POLLUTANT DETAIL INFORMATION -  
ALLOWABLE EMISSIONS**

Complete if the pollutant identified in Subsection F1 is or would be subject to a numerical emissions limitation.

**Allowable Emissions** Allowable Emissions  1  of  1

1. Basis for Allowable Emissions Code: <b>RULE (BACT)</b>	2. Future Effective Date of Allowable Emissions: N/A
3. Allowable Emissions and Units: N/A	4. Equivalent Allowable Emissions: <b>10.8 lb/hour</b> N/A tons/year
5. Method of Compliance: <b>Stack Test – EPA Reference Method 10.</b>	
6. Allowable Emissions Comment (Description of Operating Method):  <b>Rule 62-212.400(4)(c), F.A.C.</b>	

**Allowable Emissions** Allowable Emissions    of

1. Basis for Allowable Emissions Code:	2. Future Effective Date of Allowable Emissions:
3. Allowable Emissions and Units:	4. Equivalent Allowable Emissions: lb/hour      tons/year
5. Method of Compliance:	
6. Allowable Emissions Comment (Description of Operating Method):	

**Allowable Emissions** Allowable Emissions    of

1. Basis for Allowable Emissions Code:	2. Future Effective Date of Allowable Emissions:
3. Allowable Emissions and Units:	4. Equivalent Allowable Emissions: lb/hour      tons/year
5. Method of Compliance:	
6. Allowable Emissions Comment (Description of Operating Method):	

**F1. EMISSIONS UNIT POLLUTANT DETAIL INFORMATION –  
POTENTIAL, FUGITIVE, AND ACTUAL EMISSIONS**

(Optional for unregulated emissions units.)

**Potential, Estimated Fugitive, and Baseline & Projected Actual Emissions**

Complete for each pollutant identified in Subsection E if applying for an air construction permit or concurrent processing of an air construction permit and a revised or renewal Title V permit. Complete for each emissions-limited pollutant identified in Subsection E if applying for an air operation permit.

1. Pollutant Emitted: <b>VOC</b>		2. Total Percent Efficiency of Control:	
3. Potential Emissions: <b>3.2 lb/hour</b> <b>1.4 tons/year</b>		4. Synthetically Limited? <input checked="" type="checkbox"/> Yes <input type="checkbox"/> No	
5. Range of Estimated Fugitive Emissions (as applicable): <b>N/A</b> to tons/year			
6. Emission Factor: <b>0.011 lb/MMBtu</b>  Reference: <b>AP-42.</b>		7. Emissions Method Code: <b>3</b>	
8.a. Baseline Actual Emissions (if required): <b>N/A tons/year</b>		8.b. Baseline 24-month Period: <b>N/A</b> From:                      To:	
9.a. Projected Actual Emissions (if required): <b>N/A tons/year</b>		9.b. Projected Monitoring Period: <b>N/A</b> <input type="checkbox"/> 5 years <input type="checkbox"/> 10 years	
10. Calculation of Emissions:  <b>Detailed emission calculations are provided in Appendix A.</b>			
11. Potential, Fugitive, and Actual Emissions Comment:  <b>Auxiliary boiler will have a maximum capacity factor of 10%; i.e., 876 hours per year at design capacity.</b>			



**F2. EMISSIONS UNIT POLLUTANT DETAIL INFORMATION -  
 ALLOWABLE EMISSIONS N/A**

**Complete if the pollutant identified in Subsection F1 is or would be subject to a numerical emissions limitation.**

**Allowable Emissions** Allowable Emissions of

1. Basis for Allowable Emissions Code:	2. Future Effective Date of Allowable Emissions:
3. Allowable Emissions and Units:	4. Equivalent Allowable Emissions: Lb/hour                      tons/year
5. Method of Compliance:	
6. Allowable Emissions Comment (Description of Operating Method):	

**Allowable Emissions** Allowable Emissions of

1. Basis for Allowable Emissions Code:	2. Future Effective Date of Allowable Emissions:
3. Allowable Emissions and Units:	4. Equivalent Allowable Emissions: Lb/hour                      tons/year
5. Method of Compliance:	
6. Allowable Emissions Comment (Description of Operating Method):	

**Allowable Emissions** Allowable Emissions of

1. Basis for Allowable Emissions Code:	2. Future Effective Date of Allowable Emissions:
3. Allowable Emissions and Units:	4. Equivalent Allowable Emissions: Lb/hour                      tons/year
5. Method of Compliance:	
6. Allowable Emissions Comment (Description of Operating Method):	

**F1. EMISSIONS UNIT POLLUTANT DETAIL INFORMATION –  
POTENTIAL, FUGITIVE, AND ACTUAL EMISSIONS**

(Optional for unregulated emissions units.)

**Potential, Estimated Fugitive, and Baseline & Projected Actual Emissions**

Complete for each pollutant identified in Subsection E if applying for an air construction permit or concurrent processing of an air construction permit and a revised or renewal Title V permit. Complete for each emissions-limited pollutant identified in Subsection E if applying for an air operation permit.

1. Pollutant Emitted: <b>SAM</b>		2. Total Percent Efficiency of Control:	
3. Potential Emissions: Neg. lb/hour                      Neg. tons/year		4. Synthetically Limited? <input checked="" type="checkbox"/> Yes <input type="checkbox"/> No	
5. Range of Estimated Fugitive Emissions (as applicable): <b>N/A</b> to tons/year			
6. Emission Factor: <b>N/A</b> Reference: <b>ECT, 2007.</b>		7. Emissions Method Code: <b>2</b>	
8.a. Baseline Actual Emissions (if required): <b>N/A</b> tons/year		8.b. Baseline 24-month Period: <b>N/A</b> From:                      To:	
9.a. Projected Actual Emissions (if required): <b>N/A</b> tons/year		9.b. Projected Monitoring Period: <b>N/A</b> <input type="checkbox"/> 5 years <input type="checkbox"/> 10 years	
10. Calculation of Emissions:  <b>Auxiliary boiler sulfuric acid mist emissions resulting from the combustion of natural gas will be negligible.</b>			
11. Potential, Fugitive, and Actual Emissions Comment:  <b>Auxiliary boiler will have a maximum capacity factor of 10%; i.e., 876 hours per year at design capacity.</b>			

**F2. EMISSIONS UNIT POLLUTANT DETAIL INFORMATION -  
ALLOWABLE EMISSIONS**

Complete if the pollutant identified in Subsection F1 is or would be subject to a numerical emissions limitation.

**Allowable Emissions** Allowable Emissions 1 of 1

1. Basis for Allowable Emissions Code: <b>RULE (BACT)</b>	2. Future Effective Date of Allowable Emissions: N/A
3. Allowable Emissions and Units: <b>Pipeline Natural Gas</b>	4. Equivalent Allowable Emissions: N/A lb/hour      N/A tons/year
5. Method of Compliance: <b>Natural gas analysis for sulfur content.</b>	
6. Allowable Emissions Comment (Description of Operating Method):  <b>Rule 62-212.400(4)(c), F.A.C.</b>	

**Allowable Emissions** Allowable Emissions    of

1. Basis for Allowable Emissions Code:	2. Future Effective Date of Allowable Emissions:
3. Allowable Emissions and Units:	4. Equivalent Allowable Emissions: lb/hour      tons/year
5. Method of Compliance:	
6. Allowable Emissions Comment (Description of Operating Method):	

**Allowable Emissions** Allowable Emissions    of

1. Basis for Allowable Emissions Code:	2. Future Effective Date of Allowable Emissions:
3. Allowable Emissions and Units:	4. Equivalent Allowable Emissions: lb/hour      tons/year
5. Method of Compliance:	
6. Allowable Emissions Comment (Description of Operating Method):	

**EMISSIONS UNIT INFORMATION**

Section [ 3 ] of [ 10 ]

**G. VISIBLE EMISSIONS INFORMATION**

Complete if this emissions unit is or would be subject to a unit-specific visible emissions limitation.

**Visible Emissions Limitation:** Visible Emissions Limitation  1  of  2

1. Visible Emissions Subtype: <b>VE20</b>	2. Basis for Allowable Opacity: <input checked="" type="checkbox"/> Rule <input type="checkbox"/> Other
3. Allowable Opacity: Normal Conditions: <b>20 %</b> Exceptional Conditions: % Maximum Period of Excess Opacity Allowed: min/hour	
4. Method of Compliance: <b>EPA Reference Method 9</b>	
5. Visible Emissions Comment:  <b>Rule 62-296.320(4)(b), F.A.C.</b>	

**Visible Emissions Limitation:** Visible Emissions Limitation  2  of  2

1. Visible Emissions Subtype: <b>VE99</b>	2. Basis for Allowable Opacity: <input checked="" type="checkbox"/> Rule <input type="checkbox"/> Other
3. Allowable Opacity: Normal Conditions: % Exceptional Conditions: % Maximum Period of Excess Opacity Allowed: <b>60 min/hour</b>	
4. Method of Compliance: <b>EPA Reference Method 9</b>	
5. Visible Emissions Comment:  <b>Excess emissions resulting from startup, shutdown or malfunction of any emissions unit shall be permitted providing (1) best operational practices to minimize emissions are adhered to and (2) the duration of excess emissions shall be minimized but in no case exceed two hours in any 24 hour period unless specifically authorized by the Department for longer duration.</b>  <b>Rule 62-210.700(1), F.A.C.</b>	

**EMISSIONS UNIT INFORMATION**

Section [ 3 ] of [ 10 ]

**H. CONTINUOUS MONITOR INFORMATION – N/A**

**Complete if this emissions unit is or would be subject to continuous monitoring.**

**Continuous Monitoring System:** Continuous Monitor of

1. Parameter Code:	2. Pollutant(s):
3. CMS Requirement:	<input type="checkbox"/> Rule <input type="checkbox"/> Other
4. Monitor Information Manufacturer: Model Number:	Serial Number:
5. Installation Date:	6. Performance Specification Test Date:
7. Continuous Monitor Comment:	

**Continuous Monitoring System:** Continuous Monitor of

1. Parameter Code:	2. Pollutant(s):
3. CMS Requirement:	<input type="checkbox"/> Rule <input type="checkbox"/> Other
4. Monitor Information Manufacturer: Model Number:	Serial Number:
5. Installation Date:	6. Performance Specification Test Date:
7. Continuous Monitor Comment:	

**EMISSIONS UNIT INFORMATION**

Section [ 3 ] of [ 10 ]

**I. EMISSIONS UNIT ADDITIONAL INFORMATION**

**Additional Requirements for All Applications, Except as Otherwise Stated**

1. Process Flow Diagram (Required for all permit applications, except Title V air operation permit revision applications if this information was submitted to the department within the previous five years and would not be altered as a result of the revision being sought) <input checked="" type="checkbox"/> Attached, Document ID: <u>Fig. 2-4</u> <input type="checkbox"/> Previously Submitted, Date _____
2. Fuel Analysis or Specification (Required for all permit applications, except Title V air operation permit revision applications if this information was submitted to the department within the previous five years and would not be altered as a result of the revision being sought) <input checked="" type="checkbox"/> Attached, Document ID: <u>Section 2.2, Table 2-4</u>
3. Detailed Description of Control Equipment (Required for all permit applications, except Title V air operation permit revision applications if this information was submitted to the department within the previous five years and would not be altered as a result of the revision being sought) <input checked="" type="checkbox"/> Attached, Document ID: <u>Section 2.0</u> <input type="checkbox"/> Previously Submitted, Date _____
4. Procedures for Startup and Shutdown (Required for all operation permit applications, except Title V air operation permit revision applications if this information was submitted to the department within the previous five years and would not be altered as a result of the revision being sought) <input checked="" type="checkbox"/> Not Applicable (construction application)
5. Operation and Maintenance Plan (Required for all permit applications, except Title V air operation permit revision applications if this information was submitted to the department within the previous five years and would not be altered as a result of the revision being sought) <input type="checkbox"/> Attached, Document ID: _____ <input type="checkbox"/> Previously Submitted, Date _____ <input checked="" type="checkbox"/> Not Applicable
6. Compliance Demonstration Reports/Records <input type="checkbox"/> Attached, Document ID: _____ Test Date(s)/Pollutant(s) Tested: _____ _____ <input type="checkbox"/> Previously Submitted, Date: _____ Test Date(s)/Pollutant(s) Tested: _____ _____ <input type="checkbox"/> To be Submitted, Date (if known): _____ Test Date(s)/Pollutant(s) Tested: _____ _____ <input checked="" type="checkbox"/> Not Applicable  Note: For FESOP applications, all required compliance demonstration records/reports must be submitted at the time of application. For Title V air operation permit applications, all required compliance demonstration reports/records must be submitted at the time of application, or a compliance plan must be submitted at the time of application.
7. Other Information Required by Rule or Statute <input type="checkbox"/> Attached, Document ID: _____ <input checked="" type="checkbox"/> Not Applicable

**EMISSIONS UNIT INFORMATION**

Section [ 3 ] of [ 10 ]

**Additional Requirements for Air Construction Permit Applications**

1. Control Technology Review and Analysis (Rules 62-212.400(10) and 62-212.500(7), F.A.C.; 40 CFR 63.43(d) and (e)) <input checked="" type="checkbox"/> Attached, Document ID: <u>Section 5.0</u> <input type="checkbox"/> Not Applicable
2. Good Engineering Practice Stack Height Analysis (Rule 62-212.400(4)(d), F.A.C., and Rule 62-212.500(4)(f), F.A.C.) <input checked="" type="checkbox"/> Attached, Document ID: <u>Section 6.0</u> <input type="checkbox"/> Not Applicable
3. Description of Stack Sampling Facilities (Required for proposed new stack sampling facilities only) <input type="checkbox"/> Attached, Document ID: _____ <input checked="" type="checkbox"/> Not Applicable

**Additional Requirements for Title V Air Operation Permit Applications** **NOT APPLICABLE**

1. Identification of Applicable Requirements <input type="checkbox"/> Attached, Document ID: _____
2. Compliance Assurance Monitoring <input type="checkbox"/> Attached, Document ID: _____ <input type="checkbox"/> Not Applicable
3. Alternative Methods of Operation <input type="checkbox"/> Attached, Document ID: _____ <input type="checkbox"/> Not Applicable
4. Alternative Modes of Operation (Emissions Trading) <input type="checkbox"/> Attached, Document ID: _____ <input type="checkbox"/> Not Applicable
5. Acid Rain Part Application <input type="checkbox"/> Certificate of Representation (EPA Form No. 7610-1) <input type="checkbox"/> Copy Attached, Document ID: _____ <input type="checkbox"/> Acid Rain Part (Form No. 62-210.900(1)(a)) <input type="checkbox"/> Attached, Document ID: _____ <input type="checkbox"/> Previously Submitted, Date: _____ <input type="checkbox"/> Repowering Extension Plan (Form No. 62-210.900(1)(a)1.) <input type="checkbox"/> Attached, Document ID: _____ <input type="checkbox"/> Previously Submitted, Date: _____ <input type="checkbox"/> New Unit Exemption (Form No. 62-210.900(1)(a)2.) <input type="checkbox"/> Attached, Document ID: _____ <input type="checkbox"/> Previously Submitted, Date: _____ <input type="checkbox"/> Retired Unit Exemption (Form No. 62-210.900(1)(a)3.) <input type="checkbox"/> Attached, Document ID: _____ <input type="checkbox"/> Previously Submitted, Date: _____ <input type="checkbox"/> Phase II NOx Compliance Plan (Form No. 62-210.900(1)(a)4.) <input type="checkbox"/> Attached, Document ID: _____ <input type="checkbox"/> Previously Submitted, Date: _____ <input type="checkbox"/> Phase II NOx Averaging Plan (Form No. 62-210.900(1)(a)5.) <input type="checkbox"/> Attached, Document ID: _____ <input type="checkbox"/> Previously Submitted, Date: _____ <input type="checkbox"/> Not Applicable

**EMISSIONS UNIT INFORMATION**

Section [ 3 ] of [ 10 ]

**Additional Requirements Comment**

[Empty rectangular box for Additional Requirements Comment]



**EMISSIONS UNIT INFORMATION**

Section [ 4 ] of [ 10 ]

**A. GENERAL EMISSIONS UNIT INFORMATION**

**Title V Air Operation Permit Emissions Unit Classification**

1. Regulated or Unregulated Emissions Unit? (Check one, if applying for an initial, revised or renewal Title V air operation permit. Skip this item if applying for an air construction permit or FESOP only.)

The emissions unit addressed in this Emissions Unit Information Section is a regulated emissions unit.

The emissions unit addressed in this Emissions Unit Information Section is an unregulated emissions unit.

**Emissions Unit Description and Status**

1. Type of Emissions Unit Addressed in this Section: (Check one)

This Emissions Unit Information Section addresses, as a single emissions unit, a single process or production unit, or activity, which produces one or more air pollutants and which has at least one definable emission point (stack or vent).

This Emissions Unit Information Section addresses, as a single emissions unit, a group of process or production units and activities which has at least one definable emission point (stack or vent) but may also produce fugitive emissions.

This Emissions Unit Information Section addresses, as a single emissions unit, one or more process or production units and activities which produce fugitive emissions only.

2. Description of Emissions Unit Addressed in this Section:  
**10-cell mechanical draft cooling tower. Tower is equipped with drift eliminators for control of PM/PM<sub>10</sub> emissions.**

3. Emissions Unit Identification Number: **014 (Unit 6 Cooling Tower)**

4. Emissions Unit Status Code: <b>C</b>	5. Commence Construction Date: <b>N/A</b>	6. Initial Startup Date: <b>N/A</b>	7. Emissions Unit Major Group SIC Code: <b>49</b>	8. Acid Rain Unit? <input type="checkbox"/> Yes <input checked="" type="checkbox"/> No
--	--	--	--	--

9. Package Unit:  
 Manufacturer: \_\_\_\_\_ Model Number: \_\_\_\_\_

10. Generator Nameplate Rating: **MW**

11. Emissions Unit Comment:

**EMISSIONS UNIT INFORMATION**

Section [ 4 ] of [ 10 ]

**Emissions Unit Control Equipment**

1. Control Equipment/Method(s) Description:

**Drift eliminators – High Velocity (Velocity > 250 ft/min) [Control Device Code 014]**

2. Control Device or Method Code(s): **014**

**EMISSIONS UNIT INFORMATION**

Section [ 4 ] of [ 10 ]

**B. EMISSIONS UNIT CAPACITY INFORMATION**

(Optional for unregulated emissions units.)

**Emissions Unit Operating Capacity and Schedule**

1. Maximum Process or Throughput Rate: <b>145,000 gal/min</b>
2. Maximum Production Rate: <b>N/A</b>
3. Maximum Heat Input Rate: <b>N/A million Btu/hr,</b>
4. Maximum Incineration Rate: <b>N/A pounds/hr</b> <b>tons/day</b>
5. Requested Maximum Operating Schedule: <b>24 hours/day</b> <b>7 days/week</b> <b>52 weeks/year</b> <b>8,760 hours/year</b>
6. Operating Capacity/Schedule Comment:  <b>Field 1 maximum process rate is the cooling tower water recirculation rate.</b>

**EMISSIONS UNIT INFORMATION**

Section [ 4 ] of [ 10 ]

**C. EMISSION POINT (STACK/VENT) INFORMATION  
(Optional for unregulated emissions units.)**

**Emission Point Description and Type**

1. Identification of Point on Plot Plan or Flow Diagram: <b>Unit 6 Cooling Tower</b>		2. Emission Point Type Code: <b>3</b>	
3. Descriptions of Emission Points Comprising this Emissions Unit for VE Tracking:  <b>Cooling tower consists of 10 cells.</b>			
4. ID Numbers or Descriptions of Emission Units with this Emission Point in Common:  <b>N/A</b>			
5. Discharge Type Code: <b>V</b>	6. Stack Height: <b>42 feet</b>	7. Exit Diameter: <b>37.5 feet</b>	
8. Exit Temperature: <b>95 °F</b>	9. Actual Volumetric Flow Rate: <b>1,789,235 acfm</b>	10. Water Vapor: <b>N/A %</b>	
11. Maximum Dry Standard Flow Rate: <b>N/A dscfm</b>		12. Nonstack Emission Point Height: <b>N/A feet</b>	
13. Emission Point UTM Coordinates Zone: East (km): <b>N/A</b> North (km): <b>N/A</b>		14. Emission Point Latitude/Longitude <b>N/A</b> Latitude (DD/MM/SS) <b>N/A</b> Longitude (DD/MM/SS)	
15. Emission Point Comment:  <b>Cooling tower consists of 10 cells with 10 individual exhaust fans. Stack height and diameter data provided in Fields 6 and 7 are for each cell. Exhaust volume and temperature will vary with ambient temperatures.</b>			

**EMISSIONS UNIT INFORMATION**

Section [ 4 ] of [ 10 ]

**D. SEGMENT (PROCESS/FUEL) INFORMATION**

**Segment Description and Rate:** Segment 1 of 1

1. Segment Description (Process/Fuel Type):  <b>Cooling Tower – Process Cooling, Mechanical Draft</b>		
2. Source Classification Code (SCC): <b>3-85-001-01</b>		3. SCC Units: <b>Million Gallons Throughput</b>
4. Maximum Hourly Rate: <b>8.7</b>	5. Maximum Annual Rate: <b>76,212</b>	6. Estimated Annual Activity Factor: <b>N/A</b>
7. Maximum % Sulfur: <b>N/A</b>	8. Maximum % Ash: <b>N/A</b>	9. Million Btu per SCC Unit: <b>N/A</b>
10. Segment Comment:		

**Segment Description and Rate:** Segment of

1. Segment Description (Process/Fuel Type):		
2. Source Classification Code (SCC):		3. SCC Units:
4. Maximum Hourly Rate:	5. Maximum Annual Rate:	6. Estimated Annual Activity Factor:
7. Maximum % Sulfur:	8. Maximum % Ash:	9. Million Btu per SCC Unit:
10. Segment Comment:		

**EMISSIONS UNIT INFORMATION**

Section [ 4 ] of [ 10 ]

**E. EMISSIONS UNIT POLLUTANTS**

**List of Pollutants Emitted by Emissions Unit**

1. Pollutant Emitted	2. Primary Control Device Code	3. Secondary Control Device Code	4. Pollutant Regulatory Code
1 – PM	014		NS
2 – PM10	014		NS

**F1. EMISSIONS UNIT POLLUTANT DETAIL INFORMATION –  
POTENTIAL, FUGITIVE, AND ACTUAL EMISSIONS**

(Optional for unregulated emissions units.)

**Potential, Estimated Fugitive, and Baseline & Projected Actual Emissions**

**Complete for each pollutant identified in Subsection E if applying for an air construction permit or concurrent processing of an air construction permit and a revised or renewal Title V permit. Complete for each emissions-limited pollutant identified in Subsection E if applying for an air operation permit.**

1. Pollutant Emitted: <b>PM</b>		2. Total Percent Efficiency of Control: <b>N/A</b>	
3. Potential Emissions: <b>5.9 lb/hour</b> <b>25.8 tons/year</b>		4. Synthetically Limited? <input type="checkbox"/> Yes <input checked="" type="checkbox"/> No	
5. Range of Estimated Fugitive Emissions (as applicable): <b>N/A</b> to tons/year			
6. Emission Factor: <b>N/A</b>  Reference: <b>AP-42, ECT, 2007.</b>		7. Emissions Method Code: <b>2</b>	
8.a. Baseline Actual Emissions (if required): <b>N/A</b> tons/year		8.b. Baseline 24-month Period: <b>N/A</b> From:    To:	
9.a. Projected Actual Emissions (if required): <b>N/A</b> tons/year		9.b. Projected Monitoring Period: <b>N/A</b> <input type="checkbox"/> 5 years <input type="checkbox"/> 10 years	
10. Calculation of Emissions:  <b>Detailed emission calculations are provided in Appendix A.</b>			
11. Potential, Fugitive, and Actual Emissions Comment:			

**F2. EMISSIONS UNIT POLLUTANT DETAIL INFORMATION -  
ALLOWABLE EMISSIONS**

Complete if the pollutant identified in Subsection F1 is or would be subject to a numerical emissions limitation.

Allowable Emissions Allowable Emissions 1 of 1

1. Basis for Allowable Emissions Code: <b>RULE (BACT)</b>	2. Future Effective Date of Allowable Emissions: <b>N/A</b>
3. Allowable Emissions and Units: <b>0.0005-percent drift loss</b>	4. Equivalent Allowable Emissions: <b>5.9 lb/hour      25.8 tons/year</b>
5. Method of Compliance: <b>Cooling tower vendor design data</b>	
6. Allowable Emissions Comment (Description of Operating Method):	

Allowable Emissions Allowable Emissions of

1. Basis for Allowable Emissions Code:	2. Future Effective Date of Allowable Emissions:
3. Allowable Emissions and Units:	4. Equivalent Allowable Emissions: lb/hour      tons/year
5. Method of Compliance:	
6. Allowable Emissions Comment (Description of Operating Method):	



**F1. EMISSIONS UNIT POLLUTANT DETAIL INFORMATION –  
POTENTIAL, FUGITIVE, AND ACTUAL EMISSIONS**

(Optional for unregulated emissions units.)

**Potential, Estimated Fugitive, and Baseline & Projected Actual Emissions**

**Complete for each pollutant identified in Subsection E if applying for an air construction permit or concurrent processing of an air construction permit and a revised or renewal Title V permit. Complete for each emissions-limited pollutant identified in Subsection E if applying for an air operation permit.**

1. Pollutant Emitted: <b>PM10</b>		2. Total Percent Efficiency of Control: <b>N/A</b>	
3. Potential Emissions: <b>0.14 lb/hour                      0.6 tons/year</b>		4. Synthetically Limited? <input type="checkbox"/> Yes <input checked="" type="checkbox"/> No	
5. Range of Estimated Fugitive Emissions (as applicable): <b>N/A</b> to tons/year			
6. Emission Factor: <b>N/A</b>  Reference: <b>AP-42, ECT, 2007.</b>		7. Emissions Method Code: <b>2</b>	
8.a. Baseline Actual Emissions (if required): <b>N/A tons/year</b>		8.b. Baseline 24-month Period: <b>N/A</b> From:                      To:	
9.a. Projected Actual Emissions (if required): <b>N/A tons/year</b>		9.b. Projected Monitoring Period: <b>N/A</b> <input type="checkbox"/> 5 years <input type="checkbox"/> 10 years	
10. Calculation of Emissions:  <b>Detailed emission calculations are provided in Appendix A.</b>			
11. Potential, Fugitive, and Actual Emissions Comment:			

**F2. EMISSIONS UNIT POLLUTANT DETAIL INFORMATION -  
 ALLOWABLE EMISSIONS**

Complete if the pollutant identified in Subsection F1 is or would be subject to a numerical emissions limitation.

Allowable Emissions Allowable Emissions  1  of  1

1. Basis for Allowable Emissions Code: <b>RULE (BACT)</b>	2. Future Effective Date of Allowable Emissions: <b>N/A</b>
3. Allowable Emissions and Units: <b>0.0005-percent drift loss</b>	4. Equivalent Allowable Emissions: <b>0.14 lb/hour      0.6 tons/year</b>
5. Method of Compliance: <b>Cooling tower vendor design data</b>	
6. Allowable Emissions Comment (Description of Operating Method):	

Allowable Emissions Allowable Emissions    of

1. Basis for Allowable Emissions Code:	2. Future Effective Date of Allowable Emissions:
3. Allowable Emissions and Units:	4. Equivalent Allowable Emissions: lb/hour                      tons/year
5. Method of Compliance:	
6. Allowable Emissions Comment (Description of Operating Method):	

**EMISSIONS UNIT INFORMATION**

Section [ 4 ] of [ 10 ]

**G. VISIBLE EMISSIONS INFORMATION**

**Complete if this emissions unit is or would be subject to a unit-specific visible emissions limitation.**

**Visible Emissions Limitation:** Visible Emissions Limitation  1  of  1

1. Visible Emissions Subtype: <b>VE20</b>	2. Basis for Allowable Opacity: <input checked="" type="checkbox"/> Rule <input type="checkbox"/> Other
3. Allowable Opacity: Normal Conditions: <b>20 %</b> Exceptional Conditions: % Maximum Period of Excess Opacity Allowed: min/hour	
4. Method of Compliance: <b>EPA Reference Method 9</b>	
5. Visible Emissions Comment:  <b>Rule 62-296.320(4)(b), F.A.C.</b>	

**Visible Emissions Limitation:** Visible Emissions Limitation of

1. Visible Emissions Subtype:	2. Basis for Allowable Opacity: <input type="checkbox"/> Rule <input type="checkbox"/> Other
3. Allowable Opacity: Normal Conditions: % Exceptional Conditions: % Maximum Period of Excess Opacity Allowed: min/hour	
4. Method of Compliance:	
5. Visible Emissions Comment:	

**EMISSIONS UNIT INFORMATION**

Section [ 4 ] of [ 10 ]

**H. CONTINUOUS MONITOR INFORMATION – N/A**

Complete if this emissions unit is or would be subject to continuous monitoring.

**Continuous Monitoring System:** Continuous Monitor of

1. Parameter Code:	2. Pollutant(s):
3. CMS Requirement:	<input type="checkbox"/> Rule <input type="checkbox"/> Other
4. Monitor Information Manufacturer: Model Number: Serial Number:	
5. Installation Date:	6. Performance Specification Test Date:
7. Continuous Monitor Comment:	

**Continuous Monitoring System:** Continuous Monitor of

1. Parameter Code:	2. Pollutant(s):
3. CMS Requirement:	<input type="checkbox"/> Rule <input type="checkbox"/> Other
4. Monitor Information Manufacturer: Model Number: Serial Number:	
5. Installation Date:	6. Performance Specification Test Date:
7. Continuous Monitor Comment:	

**EMISSIONS UNIT INFORMATION**

Section [ 4 ] of [ 10 ]

**I. EMISSIONS UNIT ADDITIONAL INFORMATION**

**Additional Requirements for All Applications, Except as Otherwise Stated**

1. Process Flow Diagram (Required for all permit applications, except Title V air operation permit revision applications if this information was submitted to the department within the previous five years and would not be altered as a result of the revision being sought) <input checked="" type="checkbox"/> Attached, Document ID: <b>Fig. 2-4</b> <input type="checkbox"/> Previously Submitted, Date _____
2. Fuel Analysis or Specification (Required for all permit applications, except Title V air operation permit revision applications if this information was submitted to the department within the previous five years and would not be altered as a result of the revision being sought) <input type="checkbox"/> Attached, Document ID: _____ <input checked="" type="checkbox"/> Not Applicable
3. Detailed Description of Control Equipment (Required for all permit applications, except Title V air operation permit revision applications if this information was submitted to the department within the previous five years and would not be altered as a result of the revision being sought) <input checked="" type="checkbox"/> Attached, Document ID: <b>Section 2.0</b> <input type="checkbox"/> Previously Submitted, Date _____
4. Procedures for Startup and Shutdown (Required for all operation permit applications, except Title V air operation permit revision applications if this information was submitted to the department within the previous five years and would not be altered as a result of the revision being sought) <input checked="" type="checkbox"/> Not Applicable (construction application)
5. Operation and Maintenance Plan (Required for all permit applications, except Title V air operation permit revision applications if this information was submitted to the department within the previous five years and would not be altered as a result of the revision being sought) <input type="checkbox"/> Attached, Document ID: _____ <input type="checkbox"/> Previously Submitted, Date _____ <input checked="" type="checkbox"/> Not Applicable
6. Compliance Demonstration Reports/Records <input type="checkbox"/> Attached, Document ID: _____ Test Date(s)/Pollutant(s) Tested: _____ <input type="checkbox"/> Previously Submitted, Date: _____ Test Date(s)/Pollutant(s) Tested: _____ <input type="checkbox"/> To be Submitted, Date (if known): _____ Test Date(s)/Pollutant(s) Tested: _____ <input checked="" type="checkbox"/> Not Applicable  Note: For FESOP applications, all required compliance demonstration records/reports must be submitted at the time of application. For Title V air operation permit applications, all required compliance demonstration reports/records must be submitted at the time of application, or a compliance plan must be submitted at the time of application.
7. Other Information Required by Rule or Statute <input type="checkbox"/> Attached, Document ID: _____ <input checked="" type="checkbox"/> Not Applicable

**EMISSIONS UNIT INFORMATION**

Section [ 4 ] of [ 10 ]

**Additional Requirements for Air Construction Permit Applications**

1. Control Technology Review and Analysis (Rules 62-212.400(10) and 62-212.500(7), F.A.C.; 40 CFR 63.43(d) and (e)) <input checked="" type="checkbox"/> Attached, Document ID: <u>Section 5.0</u> <input type="checkbox"/> Not Applicable
2. Good Engineering Practice Stack Height Analysis (Rule 62-212.400(4)(d), F.A.C., and Rule 62-212.500(4)(f), F.A.C.) <input checked="" type="checkbox"/> Attached, Document ID: <u>Section 6.0</u> <input type="checkbox"/> Not Applicable
3. Description of Stack Sampling Facilities (Required for proposed new stack sampling facilities only) <input type="checkbox"/> Attached, Document ID: _____ <input checked="" type="checkbox"/> Not Applicable

**Additional Requirements for Title V Air Operation Permit Applications** **NOT APPLICABLE**

1. Identification of Applicable Requirements <input type="checkbox"/> Attached, Document ID: _____
2. Compliance Assurance Monitoring <input type="checkbox"/> Attached, Document ID: _____ <input type="checkbox"/> Not Applicable
3. Alternative Methods of Operation <input type="checkbox"/> Attached, Document ID: _____ <input type="checkbox"/> Not Applicable
4. Alternative Modes of Operation (Emissions Trading) <input type="checkbox"/> Attached, Document ID: _____ <input type="checkbox"/> Not Applicable
5. Acid Rain Part Application <input type="checkbox"/> Certificate of Representation (EPA Form No. 7610-1) <input type="checkbox"/> Copy Attached, Document ID: _____ <input type="checkbox"/> Acid Rain Part (Form No. 62-210.900(1)(a)) <input type="checkbox"/> Attached, Document ID: _____ <input type="checkbox"/> Previously Submitted, Date: _____ <input type="checkbox"/> Repowering Extension Plan (Form No. 62-210.900(1)(a)1.) <input type="checkbox"/> Attached, Document ID: _____ <input type="checkbox"/> Previously Submitted, Date: _____ <input type="checkbox"/> New Unit Exemption (Form No. 62-210.900(1)(a)2.) <input type="checkbox"/> Attached, Document ID: _____ <input type="checkbox"/> Previously Submitted, Date: _____ <input type="checkbox"/> Retired Unit Exemption (Form No. 62-210.900(1)(a)3.) <input type="checkbox"/> Attached, Document ID: _____ <input type="checkbox"/> Previously Submitted, Date: _____ <input type="checkbox"/> Phase II NOx Compliance Plan (Form No. 62-210.900(1)(a)4.) <input type="checkbox"/> Attached, Document ID: _____ <input type="checkbox"/> Previously Submitted, Date: _____ <input type="checkbox"/> Phase II NOx Averaging Plan (Form No. 62-210.900(1)(a)5.) <input type="checkbox"/> Attached, Document ID: _____ <input type="checkbox"/> Previously Submitted, Date: _____ <input type="checkbox"/> Not Applicable

**EMISSIONS UNIT INFORMATION**

**Section [ 4 ] of [ 10 ]**

**Additional Requirements Comment**

**EMISSIONS UNIT INFORMATION**

Section [ 5 ] of [ 10 ]

**A. GENERAL EMISSIONS UNIT INFORMATION**

**Title V Air Operation Permit Emissions Unit Classification**

1. Regulated or Unregulated Emissions Unit? (Check one, if applying for an initial, revised or renewal Title V air operation permit. Skip this item if applying for an air construction permit or FESOP only.)

- The emissions unit addressed in this Emissions Unit Information Section is a regulated emissions unit.
- The emissions unit addressed in this Emissions Unit Information Section is an unregulated emissions unit.

**Emissions Unit Description and Status**

1. Type of Emissions Unit Addressed in this Section: (Check one)

- This Emissions Unit Information Section addresses, as a single emissions unit, a single process or production unit, or activity, which produces one or more air pollutants and which has at least one definable emission point (stack or vent).
- This Emissions Unit Information Section addresses, as a single emissions unit, a group of process or production units and activities which has at least one definable emission point (stack or vent) but may also produce fugitive emissions.
- This Emissions Unit Information Section addresses, as a single emissions unit, one or more process or production units and activities which produce fugitive emissions only.

2. Description of Emissions Unit Addressed in this Section:

**Sulfuric acid plant.**

3. Emissions Unit Identification Number: **015 (Unit 6 Sulfuric Acid Plant)**

4. Emissions Unit Status Code:  
**C**

5. Commence Construction Date:  
**N/A**

6. Initial Startup Date:  
**N/A**

7. Emissions Unit Major Group SIC Code:  
**49**

8. Acid Rain Unit?  
 Yes  
 No

9. Package Unit:

Manufacturer:

Model Number:

10. Generator Nameplate Rating: **MW**

11. Emissions Unit Comment:

**Sulfuric acid plant will be a double contact process or equivalent; e.g., Haldor Topsoe Wet Sulfuric Acid (WSA) process.**



**EMISSIONS UNIT INFORMATION**

**Section [ 5 ] of [ 10 ]**

**Emissions Unit Control Equipment**

1. Control Equipment/Method(s) Description:

**Double Contact Process [Control Device Code 044] or equivalent**

2. Control Device or Method Code(s): **044**

**EMISSIONS UNIT INFORMATION**

Section [ 5 ] of [ 10 ]

**B. EMISSIONS UNIT CAPACITY INFORMATION**

(Optional for unregulated emissions units.)

**Emissions Unit Operating Capacity and Schedule**

1. Maximum Process or Throughput Rate: N/A
2. Maximum Production Rate: <b>880 tons/day 100% H<sub>2</sub>SO<sub>4</sub> Acid</b>
3. Maximum Heat Input Rate: N/A million Btu/hr,
4. Maximum Incineration Rate: N/A pounds/hr tons/day
5. Requested Maximum Operating Schedule: 24 hours/day 7 days/week 52 weeks/year <b>8,760 hours/year</b>
6. Operating Capacity/Schedule Comment:

**EMISSIONS UNIT INFORMATION**

Section [ 5 ] of [ 10 ]

**C. EMISSION POINT (STACK/VENT) INFORMATION**  
 (Optional for unregulated emissions units.)

**Emission Point Description and Type**

1. Identification of Point on Plot Plan or Flow Diagram: <b>Unit 6 Sulfuric Acid Plant</b>		2. Emission Point Type Code: <b>1</b>	
3. Descriptions of Emission Points Comprising this Emissions Unit for VE Tracking:  <b>N/A.</b>			
4. ID Numbers or Descriptions of Emission Units with this Emission Point in Common:  <b>N/A</b>			
5. Discharge Type Code: <b>V</b>	6. Stack Height: <b>275 feet</b>	7. Exit Diameter: <b>6.5 feet</b>	
8. Exit Temperature: <b>180 °F</b>	9. Actual Volumetric Flow Rate: <b>57,700 acfm</b>	10. Water Vapor: <b>N/A %</b>	
11. Maximum Dry Standard Flow Rate: <b>N/A dscfm</b>		12. Nonstack Emission Point Height: <b>N/A feet</b>	
13. Emission Point UTM Coordinates Zone: <b>17</b> East (km): <b>402.26</b> North (km): <b>3,066.76</b>		14. Emission Point Latitude/Longitude <b>N/A</b> Latitude (DD/MM/SS) <b>N/A</b> Longitude (DD/MM/SS)	
15. Emission Point Comment:			

**EMISSIONS UNIT INFORMATION**

Section [ 5 ] of [ 10 ]

**D. SEGMENT (PROCESS/FUEL) INFORMATION****Segment Description and Rate:** Segment 1 of 1

1. Segment Description (Process/Fuel Type):  <b>Sulfuric Acid Plant – Contact Process (or equivalent)</b>		
2. Source Classification Code (SCC): <b>3-01-023-01</b>		3. SCC Units: <b>Tons 100% H<sub>2</sub>SO<sub>4</sub> Acid</b>
4. Maximum Hourly Rate: <b>880</b>	5. Maximum Annual Rate: <b>7,708,800</b>	6. Estimated Annual Activity Factor: <b>N/A</b>
7. Maximum % Sulfur: <b>N/A</b>	8. Maximum % Ash: <b>N/A</b>	9. Million Btu per SCC Unit: <b>N/A</b>
10. Segment Comment:		

**Segment Description and Rate:** Segment of

1. Segment Description (Process/Fuel Type):		
2. Source Classification Code (SCC):		3. SCC Units:
4. Maximum Hourly Rate:	5. Maximum Annual Rate:	6. Estimated Annual Activity Factor:
7. Maximum % Sulfur:	8. Maximum % Ash:	9. Million Btu per SCC Unit:
10. Segment Comment:		

**EMISSIONS UNIT INFORMATION**

Section [ 5 ] of [ 10 ]

**E. EMISSIONS UNIT POLLUTANTS**

**List of Pollutants Emitted by Emissions Unit**

1. Pollutant Emitted	2. Primary Control Device Code	3. Secondary Control Device Code	4. Pollutant Regulatory Code
<b>1 – SO<sub>2</sub></b>	<b>044</b>		<b>EL</b>
<b>2 – SAM</b>	<b>044</b>		<b>EL</b>



**F2. EMISSIONS UNIT POLLUTANT DETAIL INFORMATION -  
ALLOWABLE EMISSIONS**

**Complete if the pollutant identified in Subsection F1 is or would be subject to a numerical emissions limitation.**

**Allowable Emissions** Allowable Emissions  1  of  1

1. Basis for Allowable Emissions Code: <b>RULE (BACT)</b>	2. Future Effective Date of Allowable Emissions: <b>N/A</b>
3. Allowable Emissions and Units: <b>N/A</b>	4. Equivalent Allowable Emissions: <b>36.7 lb/hour      N/A tons/year</b>
5. Method of Compliance: <b>EPA Reference Method 6C</b>	
6. Allowable Emissions Comment (Description of Operating Method):  <b>Sulfuric acid plant is also subject to the less stringent 62-296.402(2)(b) limit of 4.0 lb / ton of 100% H<sub>2</sub>SO<sub>4</sub> acid.</b>	

**Allowable Emissions** Allowable Emissions of

1. Basis for Allowable Emissions Code:	2. Future Effective Date of Allowable Emissions:
3. Allowable Emissions and Units:	4. Equivalent Allowable Emissions: lb/hour      tons/year
5. Method of Compliance:	
6. Allowable Emissions Comment (Description of Operating Method):	

**F1. EMISSIONS UNIT POLLUTANT DETAIL INFORMATION –  
POTENTIAL, FUGITIVE, AND ACTUAL EMISSIONS**

(Optional for unregulated emissions units.)

**Potential, Estimated Fugitive, and Baseline & Projected Actual Emissions**

Complete for each pollutant identified in Subsection E if applying for an air construction permit or concurrent processing of an air construction permit and a revised or renewal Title V permit. Complete for each emissions-limited pollutant identified in Subsection E if applying for an air operation permit.

1. Pollutant Emitted: <b>SAM</b>		2. Total Percent Efficiency of Control: <b>99+</b>	
3. Potential Emissions: <b>3.7 lb/hour                      16.1 tons/year</b>		4. Synthetically Limited? <input type="checkbox"/> Yes <input checked="" type="checkbox"/> No	
5. Range of Estimated Fugitive Emissions (as applicable): <b>N/A</b> to tons/year			
6. Emission Factor: <b>0.1 lb/ton 100% H<sub>2</sub>SO<sub>4</sub> Acid</b>  Reference: <b>GE Data.</b>		7. Emissions Method Code: <b>5</b>	
8.a. Baseline Actual Emissions (if required): <b>N/A tons/year</b>		8.b. Baseline 24-month Period: <b>N/A</b> From:                      To:	
9.a. Projected Actual Emissions (if required): <b>N/A tons/year</b>		9.b. Projected Monitoring Period: <b>N/A</b> <input type="checkbox"/> 5 years <input type="checkbox"/> 10 years	
10. Calculation of Emissions:  <b>Detailed emission calculations are provided in Appendix A.</b>			
11. Potential, Fugitive, and Actual Emissions Comment:			



**F2. EMISSIONS UNIT POLLUTANT DETAIL INFORMATION -  
ALLOWABLE EMISSIONS**

Complete if the pollutant identified in Subsection F1 is or would be subject to a numerical emissions limitation.

**Allowable Emissions** Allowable Emissions  1  of  1

1. Basis for Allowable Emissions Code: <b>RULE (BACT)</b>	2. Future Effective Date of Allowable Emissions: N/A
3. Allowable Emissions and Units: N/A	4. Equivalent Allowable Emissions: 3.7 lb/hour      N/A tons/year
5. Method of Compliance: <b>EPA Reference Method 8 or NCASI Method 8A</b>	
6. Allowable Emissions Comment (Description of Operating Method):  <b>Sulfuric acid plant is also subject to the less stringent 62-296.402(2)(c) limit of 0.15 lb / ton of 100% H<sub>2</sub>SO<sub>4</sub> acid.</b>	

**Allowable Emissions** Allowable Emissions    of

1. Basis for Allowable Emissions Code:	2. Future Effective Date of Allowable Emissions:
3. Allowable Emissions and Units:	4. Equivalent Allowable Emissions: lb/hour      tons/year
5. Method of Compliance:	
6. Allowable Emissions Comment (Description of Operating Method):	

**EMISSIONS UNIT INFORMATION**

Section [ 5 ] of [ 10 ]

**G. VISIBLE EMISSIONS INFORMATION**

**Complete if this emissions unit is or would be subject to a unit-specific visible emissions limitation.**

**Visible Emissions Limitation:** Visible Emissions Limitation 1 of 1

1. Visible Emissions Subtype: <b>VE10</b>	2. Basis for Allowable Opacity: <input checked="" type="checkbox"/> Rule <input type="checkbox"/> Other
3. Allowable Opacity: Normal Conditions: <b>10 %</b> Exceptional Conditions: % Maximum Period of Excess Opacity Allowed: min/hour	
4. Method of Compliance: <b>EPA Reference Method 9</b>	
5. Visible Emissions Comment:  <b>Rule 62-296.402(2)(a), F.A.C.</b>	

**Visible Emissions Limitation:** Visible Emissions Limitation of

1. Visible Emissions Subtype:	2. Basis for Allowable Opacity: <input type="checkbox"/> Rule <input type="checkbox"/> Other
3. Allowable Opacity: Normal Conditions: % Exceptional Conditions: % Maximum Period of Excess Opacity Allowed: min/hour	
4. Method of Compliance:	
5. Visible Emissions Comment:	

**EMISSIONS UNIT INFORMATION**

Section [ 2 ] of [ 10 ]

**H. CONTINUOUS MONITOR INFORMATION**

**Complete if this emissions unit is or would be subject to continuous monitoring.**

**Continuous Monitoring System:** Continuous Monitor 1 of 1

1. Parameter Code: <b>EM</b>	2. Pollutant(s): <b>SO<sub>2</sub></b>
3. CMS Requirement: <input checked="" type="checkbox"/> Rule <input type="checkbox"/> Other	
4. Monitor Information Manufacturer: Model Number: <span style="float: right;">Serial Number:</span>	
5. Installation Date:	6. Performance Specification Test Date:
7. Continuous Monitor Comment:  <b>Required by 62-296.402(4)(a), F.A.C. Specific CEMS information will be provided to FDEP when available.</b>	

**Continuous Monitoring System:** Continuous Monitor of

1. Parameter Code:	2. Pollutant(s):
3. CMS Requirement: <input type="checkbox"/> Rule <input type="checkbox"/> Other	
4. Monitor Information Manufacturer: Model Number: <span style="float: right;">Serial Number:</span>	
5. Installation Date:	6. Performance Specification Test Date:
7. Continuous Monitor Comment:	

**EMISSIONS UNIT INFORMATION**

Section [ 5 ] of [ 10 ]

**I. EMISSIONS UNIT ADDITIONAL INFORMATION**

**Additional Requirements for All Applications, Except as Otherwise Stated**

1. Process Flow Diagram (Required for all permit applications, except Title V air operation permit revision applications if this information was submitted to the department within the previous five years and would not be altered as a result of the revision being sought) <input checked="" type="checkbox"/> Attached, Document ID: <u>Fig. 2-4</u> <input type="checkbox"/> Previously Submitted, Date _____
2. Fuel Analysis or Specification (Required for all permit applications, except Title V air operation permit revision applications if this information was submitted to the department within the previous five years and would not be altered as a result of the revision being sought) <input type="checkbox"/> Attached, Document ID: _____ <input checked="" type="checkbox"/> Not Applicable
3. Detailed Description of Control Equipment (Required for all permit applications, except Title V air operation permit revision applications if this information was submitted to the department within the previous five years and would not be altered as a result of the revision being sought) <input checked="" type="checkbox"/> Attached, Document ID: <u>Section 2.0</u> <input type="checkbox"/> Previously Submitted, Date _____
4. Procedures for Startup and Shutdown (Required for all operation permit applications, except Title V air operation permit revision applications if this information was submitted to the department within the previous five years and would not be altered as a result of the revision being sought) <input checked="" type="checkbox"/> Not Applicable (construction application)
5. Operation and Maintenance Plan (Required for all permit applications, except Title V air operation permit revision applications if this information was submitted to the department within the previous five years and would not be altered as a result of the revision being sought) <input type="checkbox"/> Attached, Document ID: _____ <input type="checkbox"/> Previously Submitted, Date _____ <input checked="" type="checkbox"/> Not Applicable
6. Compliance Demonstration Reports/Records <input type="checkbox"/> Attached, Document ID: _____ Test Date(s)/Pollutant(s) Tested: _____ _____ <input type="checkbox"/> Previously Submitted, Date: _____ Test Date(s)/Pollutant(s) Tested: _____ _____ <input type="checkbox"/> To be Submitted, Date (if known): _____ Test Date(s)/Pollutant(s) Tested: _____ _____ <input checked="" type="checkbox"/> Not Applicable  Note: For FESOP applications, all required compliance demonstration records/reports must be submitted at the time of application. For Title V air operation permit applications, all required compliance demonstration reports/records must be submitted at the time of application, or a compliance plan must be submitted at the time of application.
7. Other Information Required by Rule or Statute <input type="checkbox"/> Attached, Document ID: _____ <input checked="" type="checkbox"/> Not Applicable

**EMISSIONS UNIT INFORMATION**

Section [ 5 ] of [ 10 ]

**Additional Requirements for Air Construction Permit Applications**

1. Control Technology Review and Analysis (Rules 62-212.400(10) and 62-212.500(7), F.A.C.; 40 CFR 63.43(d) and (e)) <input checked="" type="checkbox"/> Attached, Document ID: <u>Section 5.0</u> <input type="checkbox"/> Not Applicable
2. Good Engineering Practice Stack Height Analysis (Rule 62-212.400(4)(d), F.A.C., and Rule 62-212.500(4)(f), F.A.C.) <input checked="" type="checkbox"/> Attached, Document ID: <u>Section 6.0</u> <input type="checkbox"/> Not Applicable
3. Description of Stack Sampling Facilities (Required for proposed new stack sampling facilities only) <b>To be provided to FDEP when available.</b> <input type="checkbox"/> Attached, Document ID: _____ <input type="checkbox"/> Not Applicable

**Additional Requirements for Title V Air Operation Permit Applications** **NOT APPLICABLE**

1. Identification of Applicable Requirements <input type="checkbox"/> Attached, Document ID: _____
2. Compliance Assurance Monitoring <input type="checkbox"/> Attached, Document ID: _____ <input type="checkbox"/> Not Applicable
3. Alternative Methods of Operation <input type="checkbox"/> Attached, Document ID: _____ <input type="checkbox"/> Not Applicable
4. Alternative Modes of Operation (Emissions Trading) <input type="checkbox"/> Attached, Document ID: _____ <input type="checkbox"/> Not Applicable
5. Acid Rain Part Application <input type="checkbox"/> Certificate of Representation (EPA Form No. 7610-1) <input type="checkbox"/> Copy Attached, Document ID: _____ <input type="checkbox"/> Acid Rain Part (Form No. 62-210.900(1)(a)) <input type="checkbox"/> Attached, Document ID: _____ <input type="checkbox"/> Previously Submitted, Date: _____ <input type="checkbox"/> Repowering Extension Plan (Form No. 62-210.900(1)(a)1.) <input type="checkbox"/> Attached, Document ID: _____ <input type="checkbox"/> Previously Submitted, Date: _____ <input type="checkbox"/> New Unit Exemption (Form No. 62-210.900(1)(a)2.) <input type="checkbox"/> Attached, Document ID: _____ <input type="checkbox"/> Previously Submitted, Date: _____ <input type="checkbox"/> Retired Unit Exemption (Form No. 62-210.900(1)(a)3.) <input type="checkbox"/> Attached, Document ID: _____ <input type="checkbox"/> Previously Submitted, Date: _____ <input type="checkbox"/> Phase II NOx Compliance Plan (Form No. 62-210.900(1)(a)4.) <input type="checkbox"/> Attached, Document ID: _____ <input type="checkbox"/> Previously Submitted, Date: _____ <input type="checkbox"/> Phase II NOx Averaging Plan (Form No. 62-210.900(1)(a)5.) <input type="checkbox"/> Attached, Document ID: _____ <input type="checkbox"/> Previously Submitted, Date: _____ <input type="checkbox"/> Not Applicable

**EMISSIONS UNIT INFORMATION**

**Section [ 5 ] of [ 10 ]**

**Additional Requirements Comment**

[Empty rectangular box for comment]

**EMISSIONS UNIT INFORMATION**

Section [ 6 ] of [ 10 ]

**A. GENERAL EMISSIONS UNIT INFORMATION**

**Title V Air Operation Permit Emissions Unit Classification**

1. Regulated or Unregulated Emissions Unit? (Check one, if applying for an initial, revised or renewal Title V air operation permit. Skip this item if applying for an air construction permit or FESOP only.)

- The emissions unit addressed in this Emissions Unit Information Section is a regulated emissions unit.
- The emissions unit addressed in this Emissions Unit Information Section is an unregulated emissions unit.

**Emissions Unit Description and Status**

1. Type of Emissions Unit Addressed in this Section: (Check one)

- This Emissions Unit Information Section addresses, as a single emissions unit, a single process or production unit, or activity, which produces one or more air pollutants and which has at least one definable emission point (stack or vent).
- This Emissions Unit Information Section addresses, as a single emissions unit, a group of process or production units and activities which has at least one definable emission point (stack or vent) but may also produce fugitive emissions.
- This Emissions Unit Information Section addresses, as a single emissions unit, one or more process or production units and activities which produce fugitive emissions only.

2. Description of Emissions Unit Addressed in this Section:  
**Flare used to combust syngas during gasifier startups, shutdowns, and process upsets.**

3. Emissions Unit Identification Number: **016 (Unit 6 Flare)**

4. Emissions Unit Status Code: <b>C</b>	5. Commence Construction Date: <b>N/A</b>	6. Initial Startup Date: <b>N/A</b>	7. Emissions Unit Major Group SIC Code: <b>49</b>	8. Acid Rain Unit? <input type="checkbox"/> Yes <input checked="" type="checkbox"/> No
--	--	--	--	--

9. Package Unit:  
 Manufacturer: \_\_\_\_\_ Model Number: \_\_\_\_\_

10. Generator Nameplate Rating:

11. Emissions Unit Comment:

**EMISSIONS UNIT INFORMATION**

**Section [ 6 ] of [ 10 ]**

**Emissions Unit Control Equipment**

1. Control Equipment/Method(s) Description:

**Flaring [023]**

2. Control Device or Method Code(s): **023**



**EMISSIONS UNIT INFORMATION**

Section [ 6 ] of [ 10 ]

**B. EMISSIONS UNIT CAPACITY INFORMATION**

(Optional for unregulated emissions units.)

**Emissions Unit Operating Capacity and Schedule**

1. Maximum Process or Throughput Rate: N/A
2. Maximum Production Rate: N/A
3. Maximum Heat Input Rate: N/A million Btu/hr,
4. Maximum Incineration Rate: N/A pounds/hr tons/day
5. Requested Maximum Operating Schedule: 24 hours/day 7 days/week 52 weeks/year 8,760 hours/year
6. Operating Capacity/Schedule Comment:  <b>Flare will be used to combust syngas during gasifier startups, shutdowns, and process upsets.</b>

**EMISSIONS UNIT INFORMATION**

Section [ 6 ] of [ 10 ]

**C. EMISSION POINT (STACK/VENT) INFORMATION  
(Optional for unregulated emissions units.)**

**Emission Point Description and Type**

1. Identification of Point on Plot Plan or Flow Diagram: <b>Unit 6 Flare</b>		2. Emission Point Type Code: <b>1</b>	
3. Descriptions of Emission Points Comprising this Emissions Unit for VE Tracking:  N/A			
4. ID Numbers or Descriptions of Emission Units with this Emission Point in Common:  N/A			
5. Discharge Type Code: <b>V</b>	6. Stack Height: <b>200 feet</b>	7. Exit Diameter: <b>N/A feet</b>	
8. Exit Temperature: <b>N/A °F</b>	9. Actual Volumetric Flow Rate: <b>N/A acfm</b>	10. Water Vapor: <b>N/A %</b>	
11. Maximum Dry Standard Flow Rate: <b>N/A dscfm</b>		12. Nonstack Emission Point Height: <b>N/A feet</b>	
13. Emission Point UTM Coordinates Zone: East (km): <b>N/A</b> North (km): <b>N/A</b>		14. Emission Point Latitude/Longitude <b>N/A</b> Latitude (DD/MM/SS) <b>N/A</b> Longitude (DD/MM/SS)	
15. Emission Point Comment:			

**EMISSIONS UNIT INFORMATION**

Section [ 6 ] of [ 10 ]

**D. SEGMENT (PROCESS/FUEL) INFORMATION**

**Segment Description and Rate:** Segment  1  of  1

1. Segment Description (Process/Fuel Type):  <b>Flaring of syngas during gasifier startups, shutdowns, and process upsets.</b>		
2. Source Classification Code (SCC): <b>N/A</b>		3. SCC Units: <b>N/A</b>
4. Maximum Hourly Rate: <b>Variable</b>	5. Maximum Annual Rate: <b>Variable</b>	6. Estimated Annual Activity Factor: <b>N/A</b>
7. Maximum % Sulfur: <b>N/A</b>	8. Maximum % Ash: <b>N/A</b>	9. Million Btu per SCC Unit: <b>N/A</b>
10. Segment Comment:		

**Segment Description and Rate:** Segment of

1. Segment Description (Process/Fuel Type):		
2. Source Classification Code (SCC):		3. SCC Units:
4. Maximum Hourly Rate:	5. Maximum Annual Rate:	6. Estimated Annual Activity Factor:
7. Maximum % Sulfur:	8. Maximum % Ash:	9. Million Btu per SCC Unit:
10. Segment Comment:		

**EMISSIONS UNIT INFORMATION**

Section [ 6 ] of [ 10 ]

**E. EMISSIONS UNIT POLLUTANTS**

**List of Pollutants Emitted by Emissions Unit**

1. Pollutant Emitted	2. Primary Control Device Code	3. Secondary Control Device Code	4. Pollutant Regulatory Code
<b>1 – NOX</b>			<b>WP</b>
<b>2 – CO</b>			<b>WP</b>
<b>3 – VOC</b>			<b>NS</b>
<b>4 – SO2</b>			<b>WP</b>
<b>5 – PM</b>			<b>WP</b>
<b>6 – PM10</b>			<b>WP</b>
<b>Notes:</b>			<b>WP – work practice</b>
			<b>NS – no standard</b>

**F1. EMISSIONS UNIT POLLUTANT DETAIL INFORMATION –  
POTENTIAL, FUGITIVE, AND ACTUAL EMISSIONS**

(Optional for unregulated emissions units.)

**Potential, Estimated Fugitive, and Baseline & Projected Actual Emissions**

**Complete for each pollutant identified in Subsection E if applying for an air construction permit or concurrent processing of an air construction permit and a revised or renewal Title V permit. Complete for each emissions-limited pollutant identified in Subsection E if applying for an air operation permit.**

1. Pollutant Emitted: <b>NOX</b>		2. Total Percent Efficiency of Control: <b>N/A</b>	
3. Potential Emissions: <b>N/A lb/hour                      3.8 tons/year</b>		4. Synthetically Limited? <input type="checkbox"/> Yes <input checked="" type="checkbox"/> No	
5. Range of Estimated Fugitive Emissions (as applicable): <b>N/A</b> to tons/year			
6. Emission Factor: <b>N/A</b>  Reference: <b>GE Data</b>		7. Emissions Method Code: <b>2</b>	
8.a. Baseline Actual Emissions (if required): <b>N/A tons/year</b>		8.b. Baseline 24-month Period: <b>N/A</b> From:                      To:	
9.a. Projected Actual Emissions (if required): <b>N/A tons/year</b>		9.b. Projected Monitoring Period: <b>N/A</b> <input type="checkbox"/> 5 years <input type="checkbox"/> 10 years	
10. Calculation of Emissions:  <b>Detailed emission calculations are provided in Appendix A.</b>			
11. Potential, Fugitive, and Actual Emissions Comment:			

**F2. EMISSIONS UNIT POLLUTANT DETAIL INFORMATION -  
 ALLOWABLE EMISSIONS**

**Complete if the pollutant identified in Subsection F1 is or would be subject to a numerical emissions limitation.**

**Allowable Emissions** Allowable Emissions  1  of  1

1. Basis for Allowable Emissions Code: <b>RULE (BACT)</b>	2. Future Effective Date of Allowable Emissions: <b>N/A</b>
3. Allowable Emissions and Units: <b>Clean Fuels, Good Combustion Practice</b>	4. Equivalent Allowable Emissions: <b>N/A lb/hour      N/A tons/year</b>
5. Method of Compliance: <b>N/A</b>	
6. Allowable Emissions Comment (Description of Operating Method):	

**Allowable Emissions** Allowable Emissions of

1. Basis for Allowable Emissions Code:	2. Future Effective Date of Allowable Emissions:
3. Allowable Emissions and Units:	4. Equivalent Allowable Emissions: <b>lb/hour      tons/year</b>
5. Method of Compliance:	
6. Allowable Emissions Comment (Description of Operating Method):	

F1. EMISSIONS UNIT POLLUTANT DETAIL INFORMATION –  
POTENTIAL, FUGITIVE, AND ACTUAL EMISSIONS  
(Optional for unregulated emissions units.)

Potential, Estimated Fugitive, and Baseline & Projected Actual Emissions

Complete for each pollutant identified in Subsection E if applying for an air construction permit or concurrent processing of an air construction permit and a revised or renewal Title V permit. Complete for each emissions-limited pollutant identified in Subsection E if applying for an air operation permit.

1. Pollutant Emitted: <b>CO</b>	2. Total Percent Efficiency of Control: <b>N/A</b>
3. Potential Emissions: <b>N/A lb/hour      16.0 tons/year</b>	4. Synthetically Limited? <input type="checkbox"/> Yes <input checked="checked" type="checkbox"/> No
5. Range of Estimated Fugitive Emissions (as applicable): <b>N/A</b> to tons/year	
6. Emission Factor: <b>N/A</b> Reference: <b>GE Data</b>	7. Emissions Method Code: <b>2</b>
8.a. Baseline Actual Emissions (if required): <b>N/A tons/year</b>	8.b. Baseline 24-month Period: <b>N/A</b> From:                          To:
9.a. Projected Actual Emissions (if required): <b>N/A tons/year</b>	9.b. Projected Monitoring Period: <b>N/A</b> <input type="checkbox"/> 5 years <input type="checkbox"/> 10 years
10. Calculation of Emissions:  <b>Detailed emission calculations are provided in Appendix A.</b>	
11. Potential, Fugitive, and Actual Emissions Comment:	

**F2. EMISSIONS UNIT POLLUTANT DETAIL INFORMATION -  
ALLOWABLE EMISSIONS**

Complete if the pollutant identified in Subsection F1 is or would be subject to a numerical emissions limitation.

Allowable Emissions Allowable Emissions 1 of 1

1. Basis for Allowable Emissions Code: <b>RULE (BACT)</b>	2. Future Effective Date of Allowable Emissions: <b>N/A</b>
3. Allowable Emissions and Units: <b>Clean Fuels, Good Combustion Practice</b>	4. Equivalent Allowable Emissions: <b>N/A lb/hour      N/A tons/year</b>
5. Method of Compliance: <b>N/A</b>	
6. Allowable Emissions Comment (Description of Operating Method):	

Allowable Emissions Allowable Emissions of

1. Basis for Allowable Emissions Code:	2. Future Effective Date of Allowable Emissions:
3. Allowable Emissions and Units:	4. Equivalent Allowable Emissions: <b>lb/hour      tons/year</b>
5. Method of Compliance:	
6. Allowable Emissions Comment (Description of Operating Method):	



**F1. EMISSIONS UNIT POLLUTANT DETAIL INFORMATION –  
 POTENTIAL, FUGITIVE, AND ACTUAL EMISSIONS**

(Optional for unregulated emissions units.)

**Potential, Estimated Fugitive, and Baseline & Projected Actual Emissions**

**Complete for each pollutant identified in Subsection E if applying for an air construction permit or concurrent processing of an air construction permit and a revised or renewal Title V permit. Complete for each emissions-limited pollutant identified in Subsection E if applying for an air operation permit.**

1. Pollutant Emitted: <b>SO2</b>		2. Total Percent Efficiency of Control: <b>N/A</b>	
3. Potential Emissions: <b>N/A lb/hour</b> <b>51.2 tons/year</b>		4. Synthetically Limited? <input type="checkbox"/> Yes <input checked="" type="checkbox"/> No	
5. Range of Estimated Fugitive Emissions (as applicable): <b>N/A</b> to tons/year			
6. Emission Factor: <b>N/A</b>  Reference: <b>GE Data</b>		7. Emissions Method Code: <b>2</b>	
8.a. Baseline Actual Emissions (if required): <b>N/A tons/year</b>		8.b. Baseline 24-month Period: <b>N/A</b> From:    To:	
9.a. Projected Actual Emissions (if required): <b>N/A tons/year</b>		9.b. Projected Monitoring Period: <b>N/A</b> <input type="checkbox"/> 5 years <input type="checkbox"/> 10 years	
10. Calculation of Emissions:  <b>Detailed emission calculations are provided in Appendix A.</b>			
11. Potential, Fugitive, and Actual Emissions Comment:			

**F2. EMISSIONS UNIT POLLUTANT DETAIL INFORMATION -  
 ALLOWABLE EMISSIONS**

**Complete if the pollutant identified in Subsection F1 is or would be subject to a numerical emissions limitation.**

**Allowable Emissions** Allowable Emissions  1  of  1

1. Basis for Allowable Emissions Code: <b>RULE (BACT)</b>	2. Future Effective Date of Allowable Emissions: <b>N/A</b>
3. Allowable Emissions and Units: <b>Clean Fuels, Good Combustion Practice</b>	4. Equivalent Allowable Emissions: <b>N/A lb/hour            N/A tons/year</b>
5. Method of Compliance: <b>N/A</b>	
6. Allowable Emissions Comment (Description of Operating Method):	

**Allowable Emissions** Allowable Emissions of

1. Basis for Allowable Emissions Code:	2. Future Effective Date of Allowable Emissions:
3. Allowable Emissions and Units:	4. Equivalent Allowable Emissions: <b>lb/hour            tons/year</b>
5. Method of Compliance:	
6. Allowable Emissions Comment (Description of Operating Method):	

**F1. EMISSIONS UNIT POLLUTANT DETAIL INFORMATION –  
POTENTIAL, FUGITIVE, AND ACTUAL EMISSIONS**

(Optional for unregulated emissions units.)

**Potential, Estimated Fugitive, and Baseline & Projected Actual Emissions**

Complete for each pollutant identified in Subsection E if applying for an air construction permit or concurrent processing of an air construction permit and a revised or renewal Title V permit. Complete for each emissions-limited pollutant identified in Subsection E if applying for an air operation permit.

1. Pollutant Emitted: <b>PM/PM10</b>		2. Total Percent Efficiency of Control: <b>N/A</b>	
3. Potential Emissions: <b>N/A</b> lb/hour <b>0.07</b> tons/year		4. Synthetically Limited? <input type="checkbox"/> Yes <input checked="" type="checkbox"/> No	
5. Range of Estimated Fugitive Emissions (as applicable): <b>N/A</b> to tons/year			
6. Emission Factor: <b>N/A</b>  Reference: <b>GE Data</b>		7. Emissions Method Code: <b>2</b>	
8.a. Baseline Actual Emissions (if required): <b>N/A</b> tons/year		8.b. Baseline 24-month Period: <b>N/A</b> From:                                      To:	
9.a. Projected Actual Emissions (if required): <b>N/A</b> tons/year		9.b. Projected Monitoring Period: <b>N/A</b> <input type="checkbox"/> 5 years <input type="checkbox"/> 10 years	
10. Calculation of Emissions:  <b>Detailed emission calculations are provided in Appendix A.</b>			
11. Potential, Fugitive, and Actual Emissions Comment:			

**F2. EMISSIONS UNIT POLLUTANT DETAIL INFORMATION -  
 ALLOWABLE EMISSIONS**

Complete if the pollutant identified in Subsection F1 is or would be subject to a numerical emissions limitation.

Allowable Emissions Allowable Emissions **1** of **1**

1. Basis for Allowable Emissions Code: <b>RULE (BACT)</b>	2. Future Effective Date of Allowable Emissions: <b>N/A</b>
3. Allowable Emissions and Units: <b>Clean Fuels, Good Combustion Practice</b>	4. Equivalent Allowable Emissions: <b>N/A lb/hour      N/A tons/year</b>
5. Method of Compliance: <b>N/A</b>	
6. Allowable Emissions Comment (Description of Operating Method):	

Allowable Emissions Allowable Emissions of

1. Basis for Allowable Emissions Code:	2. Future Effective Date of Allowable Emissions:
3. Allowable Emissions and Units:	4. Equivalent Allowable Emissions: <b>lb/hour      tons/year</b>
5. Method of Compliance:	
6. Allowable Emissions Comment (Description of Operating Method):	

**F1. EMISSIONS UNIT POLLUTANT DETAIL INFORMATION –  
 POTENTIAL, FUGITIVE, AND ACTUAL EMISSIONS**

**(Optional for unregulated emissions units.)**

**Potential, Estimated Fugitive, and Baseline & Projected Actual Emissions**

**Complete for each pollutant identified in Subsection E if applying for an air construction permit or concurrent processing of an air construction permit and a revised or renewal Title V permit. Complete for each emissions-limited pollutant identified in Subsection E if applying for an air operation permit.**

1. Pollutant Emitted: <b>VOC</b>	2. Total Percent Efficiency of Control: <b>N/A</b>
3. Potential Emissions: <b>N/A lb/hour                      0.05 tons/year</b>	4. Synthetically Limited? <input type="checkbox"/> Yes <input checked="" type="checkbox"/> No
5. Range of Estimated Fugitive Emissions (as applicable): <b>N/A</b> to tons/year	
6. Emission Factor: <b>N/A</b>  Reference: <b>GE Data</b>	7. Emissions Method Code: <b>2</b>
8.a. Baseline Actual Emissions (if required): <b>N/A tons/year</b>	8.b. Baseline 24-month Period: <b>N/A</b> From:                      To:
9.a. Projected Actual Emissions (if required): <b>N/A tons/year</b>	9.b. Projected Monitoring Period: <b>N/A</b> <input type="checkbox"/> 5 years <input type="checkbox"/> 10 years
10. Calculation of Emissions:  <p style="text-align: center;"><b>Detailed emission calculations are provided in Appendix A.</b></p>	
11. Potential, Fugitive, and Actual Emissions Comment:	

**F2. EMISSIONS UNIT POLLUTANT DETAIL INFORMATION -  
 ALLOWABLE EMISSIONS N/A**

**Complete if the pollutant identified in Subsection F1 is or would be subject to a numerical emissions limitation.**

**Allowable Emissions** Allowable Emissions of

1. Basis for Allowable Emissions Code:	2. Future Effective Date of Allowable Emissions:
3. Allowable Emissions and Units:	4. Equivalent Allowable Emissions: lb/hour                      tons/year
5. Method of Compliance:	
6. Allowable Emissions Comment (Description of Operating Method):	

**Allowable Emissions** Allowable Emissions of

1. Basis for Allowable Emissions Code:	2. Future Effective Date of Allowable Emissions:
3. Allowable Emissions and Units:	4. Equivalent Allowable Emissions: lb/hour                      tons/year
5. Method of Compliance:	
6. Allowable Emissions Comment (Description of Operating Method):	

**EMISSIONS UNIT INFORMATION**

Section [ 6 ] of [ 10 ]

**G. VISIBLE EMISSIONS INFORMATION**

**Complete if this emissions unit is or would be subject to a unit-specific visible emissions limitation.**

**Visible Emissions Limitation:** Visible Emissions Limitation  1  of  1

1. Visible Emissions Subtype: <b>VE20</b>	2. Basis for Allowable Opacity: <input checked="" type="checkbox"/> Rule <input type="checkbox"/> Other
3. Allowable Opacity: Normal Conditions: <b>20 %</b> Exceptional Conditions: % Maximum Period of Excess Opacity Allowed: min/hour	
4. Method of Compliance: <b>EPA Reference Method 9</b>	
5. Visible Emissions Comment:  <b>Rule 62-296.320(4)(b), F.A.C.</b>	

**Visible Emissions Limitation:** Visible Emissions Limitation \_\_\_ of \_\_\_

1. Visible Emissions Subtype:	2. Basis for Allowable Opacity: <input type="checkbox"/> Rule <input type="checkbox"/> Other
3. Allowable Opacity: Normal Conditions: % Exceptional Conditions: % Maximum Period of Excess Opacity Allowed: min/hour	
4. Method of Compliance:	
5. Visible Emissions Comment	

**EMISSIONS UNIT INFORMATION**

Section [ 6 ] of [ 10 ]

**H. CONTINUOUS MONITOR INFORMATION** **NOT APPLICABLE**

**Complete if this emissions unit is or would be subject to continuous monitoring.**

**Continuous Monitoring System:** Continuous Monitor of

1. Parameter Code:	2. Pollutant(s):
3. CMS Requirement:	<input type="checkbox"/> Rule <input type="checkbox"/> Other
4. Monitor Information Manufacturer: Model Number: .. Serial Number:	
5. Installation Date:	6. Performance Specification Test Date:
7. Continuous Monitor Comment:	

**Continuous Monitoring System:** Continuous Monitor of

1. Parameter Code:	2. Pollutant(s):
3. CMS Requirement:	<input type="checkbox"/> Rule <input type="checkbox"/> Other
4. Monitor Information Manufacturer: Model Number: .. Serial Number:	
5. Installation Date:	6. Performance Specification Test Date:
7. Continuous Monitor Comment:	



**EMISSIONS UNIT INFORMATION**

Section [ 6 ] of [ 10 ]

**I. EMISSIONS UNIT ADDITIONAL INFORMATION**

**Additional Requirements for All Applications, Except as Otherwise Stated**

1. Process Flow Diagram (Required for all permit applications, except Title V air operation permit revision applications if this information was submitted to the department within the previous five years and would not be altered as a result of the revision being sought) <input checked="" type="checkbox"/> Attached, Document ID: <u>Fig. 2-4</u> <input type="checkbox"/> Previously Submitted, Date _____
2. Fuel Analysis or Specification (Required for all permit applications, except Title V air operation permit revision applications if this information was submitted to the department within the previous five years and would not be altered as a result of the revision being sought) <input checked="" type="checkbox"/> Attached, Document ID: <u>Section 2.2, Tables 2-2 and 2-4</u>
3. Detailed Description of Control Equipment (Required for all permit applications, except Title V air operation permit revision applications if this information was submitted to the department within the previous five years and would not be altered as a result of the revision being sought) <input checked="" type="checkbox"/> Attached, Document ID: <u>Section 2.0</u> <input type="checkbox"/> Previously Submitted, Date _____
4. Procedures for Startup and Shutdown (Required for all operation permit applications, except Title V air operation permit revision applications if this information was submitted to the department within the previous five years and would not be altered as a result of the revision being sought) <input checked="" type="checkbox"/> Not Applicable (construction application)
5. Operation and Maintenance Plan (Required for all permit applications, except Title V air operation permit revision applications if this information was submitted to the department within the previous five years and would not be altered as a result of the revision being sought) <input type="checkbox"/> Attached, Document ID: _____ <input type="checkbox"/> Previously Submitted, Date _____ <input checked="" type="checkbox"/> Not Applicable
6. Compliance Demonstration Reports/Records <input type="checkbox"/> Attached, Document ID: _____ Test Date(s)/Pollutant(s) Tested: _____ <input type="checkbox"/> Previously Submitted, Date: _____ Test Date(s)/Pollutant(s) Tested: _____ <input type="checkbox"/> To be Submitted, Date (if known): _____ Test Date(s)/Pollutant(s) Tested: _____ <input checked="" type="checkbox"/> Not Applicable  Note: For FESOP applications, all required compliance demonstration records/reports must be submitted at the time of application. For Title V air operation permit applications, all required compliance demonstration reports/records must be submitted at the time of application, or a compliance plan must be submitted at the time of application.
7. Other Information Required by Rule or Statute <input type="checkbox"/> Attached, Document ID: _____ <input checked="" type="checkbox"/> Not Applicable

**EMISSIONS UNIT INFORMATION**

Section [ 6 ] of [ 10 ]

**Additional Requirements for Air Construction Permit Applications**

1. Control Technology Review and Analysis (Rules 62-212.400(10) and 62-212.500(7), F.A.C.; 40 CFR 63.43(d) and (e)) <input checked="" type="checkbox"/> Attached, Document ID: <u>Section 5.0</u> <input type="checkbox"/> Not Applicable
2. Good Engineering Practice Stack Height Analysis (Rule 62-212.400(4)(d), F.A.C., and Rule 62-212.500(4)(f), F.A.C.) <input checked="" type="checkbox"/> Attached, Document ID: <u>Section 6.0</u> <input type="checkbox"/> Not Applicable
3. Description of Stack Sampling Facilities (Required for proposed new stack sampling facilities only) <input type="checkbox"/> Attached, Document ID: _____ <input checked="" type="checkbox"/> Not Applicable

**Additional Requirements for Title V Air Operation Permit Applications** **NOT APPLICABLE**

1. Identification of Applicable Requirements <input type="checkbox"/> Attached, Document ID: _____
2. Compliance Assurance Monitoring <input type="checkbox"/> Attached, Document ID: _____ <input type="checkbox"/> Not Applicable
3. Alternative Methods of Operation <input type="checkbox"/> Attached, Document ID: _____ <input type="checkbox"/> Not Applicable
4. Alternative Modes of Operation (Emissions Trading) <input type="checkbox"/> Attached, Document ID: _____ <input type="checkbox"/> Not Applicable
5. Acid Rain Part Application <input type="checkbox"/> Certificate of Representation (EPA Form No. 7610-1) <input type="checkbox"/> Copy Attached, Document ID: _____ <input type="checkbox"/> Acid Rain Part (Form No. 62-210.900(1)(a)) <input type="checkbox"/> Attached, Document ID: _____ <input type="checkbox"/> Previously Submitted, Date: _____ <input type="checkbox"/> Repowering Extension Plan (Form No. 62-210.900(1)(a)1.) <input type="checkbox"/> Attached, Document ID: _____ <input type="checkbox"/> Previously Submitted, Date: _____ <input type="checkbox"/> New Unit Exemption (Form No. 62-210.900(1)(a)2.) <input type="checkbox"/> Attached, Document ID: _____ <input type="checkbox"/> Previously Submitted, Date: _____ <input type="checkbox"/> Retired Unit Exemption (Form No. 62-210.900(1)(a)3.) <input type="checkbox"/> Attached, Document ID: _____ <input type="checkbox"/> Previously Submitted, Date: _____ <input type="checkbox"/> Phase II NOx Compliance Plan (Form No. 62-210.900(1)(a)4.) <input type="checkbox"/> Attached, Document ID: _____ <input type="checkbox"/> Previously Submitted, Date: _____ <input type="checkbox"/> Phase II NOx Averaging Plan (Form No. 62-210.900(1)(a)5.) <input type="checkbox"/> Attached, Document ID: _____ <input type="checkbox"/> Previously Submitted, Date: _____ <input type="checkbox"/> Not Applicable

**EMISSIONS UNIT INFORMATION**

**Section [ 6 ] of [ 10 ]**

**Additional Requirements Comment**

[Empty comment box]

**EMISSIONS UNIT INFORMATION**

Section [ 7 ] of [ 10 ]

**A. GENERAL EMISSIONS UNIT INFORMATION**

**Title V Air Operation Permit Emissions Unit Classification**

1. Regulated or Unregulated Emissions Unit? (Check one, if applying for an initial, revised or renewal Title V air operation permit. Skip this item if applying for an air construction permit or FESOP only.)

- The emissions unit addressed in this Emissions Unit Information Section is a regulated emissions unit.
- The emissions unit addressed in this Emissions Unit Information Section is an unregulated emissions unit.

**Emissions Unit Description and Status**

1. Type of Emissions Unit Addressed in this Section: (Check one)

- This Emissions Unit Information Section addresses, as a single emissions unit, a single process or production unit, or activity, which produces one or more air pollutants and which has at least one definable emission point (stack or vent).
- This Emissions Unit Information Section addresses, as a single emissions unit, a group of process or production units and activities which has at least one definable emission point (stack or vent) but may also produce fugitive emissions.
- This Emissions Unit Information Section addresses, as a single emissions unit, one or more process or production units and activities which produce fugitive emissions only.

2. Description of Emissions Unit Addressed in this Section:

**Gasifier feedstock and byproduct unloading, transfer, conveying, and storage systems.**

3. Emissions Unit Identification Number: **017 (Unit 6 Material Handling and Storage)**

4. Emissions Unit Status Code: <b>C</b>	5. Commence Construction Date: <b>N/A</b>	6. Initial Startup Date: <b>N/A</b>	7. Emissions Unit Major Group SIC Code: <b>49</b>	8. Acid Rain Unit? <input type="checkbox"/> Yes <input checked="" type="checkbox"/> No
--	--	--	--	--

9. Package Unit:  
Manufacturer:

Model Number:

10. Generator Nameplate Rating: **MW**

11. Emissions Unit Comment:

**EMISSIONS UNIT INFORMATION**

Section | 7 | of | 10 |

**Emissions Unit Control Equipment**

1. Control Equipment/Method(s) Description:

**Fabric Filters - Low Temperature (< 180°F) [Control Device/Method Code 018]**

**Process Enclosure [Control Device/Method Code 054]**

**Dust Suppression By Water Sprays [Control Device/Method Code 061]**

**Dust Suppression By Chemical Stabilizers or Wetting Agents  
[Control Device/Method Code 062]**

**Dust Suppression By Physical Stabilization [Control Device/Method Code 106]**

**Dust Suppression – Traffic Control [Control Device/Method Code 108]**

2. Control Device or Method Code(s): **018, 054, 061, 062, 106, and 108**

**EMISSIONS UNIT INFORMATION**

Section [ 7 ] of [ 10 ]

**B. EMISSIONS UNIT CAPACITY INFORMATION**

**(Optional for unregulated emissions units.)**

**Emissions Unit Operating Capacity and Schedule**

1. Maximum Process or Throughput Rate: <b>Section 2.0</b>
2. Maximum Production Rate: N/A
3. Maximum Heat Input Rate: N/A million Btu/hr,
4. Maximum Incineration Rate: N/A pounds/hr tons/day
5. Requested Maximum Operating Schedule: 24 hours/day 7 days/week 52 weeks/year 8,760 hours/year
6. Operating Capacity/Schedule Comment:  <b>Gasifier feedstock and byproduct material handling and storage system throughput rates are discussed in Section 2.0.</b>

**EMISSIONS UNIT INFORMATION**

Section [ 7 ] of [ 10 ]

**C. EMISSION POINT (STACK/VENT) INFORMATION**  
 (Optional for unregulated emissions units.)

**Emission Point Description and Type**

1. Identification of Point on Plot Plan or Flow Diagram: <b>N/A</b>		2. Emission Point Type Code: <b>3 and 4</b>	
3. Descriptions of Emission Points Comprising this Emissions Unit for VE Tracking:  <b>Gasifier feedstock and byproduct material handling and storage systems including material transfer, storage silos and piles, and vehicular traffic on paved and unpaved roads.</b>			
4. ID Numbers or Descriptions of Emission Units with this Emission Point in Common:  <b>N/A</b>			
5. Discharge Type Code: <b>F and V</b>	6. Stack Height: <b>N/A</b> feet	7. Exit Diameter: <b>N/A</b> feet	
8. Exit Temperature: <b>77 °F</b>	9. Actual Volumetric Flow Rate: <b>N/A</b> acfm	10. Water Vapor: <b>N/A</b> %	
11. Maximum Dry Standard Flow Rate: <b>N/A</b> dscfm		12. Nonstack Emission Point Height: <b>N/A</b> feet	
13. Emission Point UTM Coordinates Zone: East (km): <b>N/A</b> North (km): <b>N/A</b>		14. Emission Point Latitude/Longitude <b>N/A</b> Latitude (DD/MM/SS) <b>N/A</b> Longitude (DD/MM/SS)	
15. Emission Point Comment:  <b>Information regarding the material handling point source stack parameters is provided in Appendix A.</b>			

**EMISSIONS UNIT INFORMATION**

Section [ 7 ] of [ 10 ]

**D. SEGMENT (PROCESS/FUEL) INFORMATION**

**Segment Description and Rate:** Segment 1 of 1

1. Segment Description (Process/Fuel Type):  <b>Gasifier Feedstock (Coal, Petcoke, and Biomass) Handling</b>		
2. Source Classification Code (SCC): <b>3-05-101-03</b>		3. SCC Units: <b>Tons Transferred</b>
4. Maximum Hourly Rate: <b>3,000</b>	5. Maximum Annual Rate: <b>2,233,800</b>	6. Estimated Annual Activity Factor: <b>N/A</b>
7. Maximum % Sulfur: <b>N/A</b>	8. Maximum % Ash: <b>N/A</b>	9. Million Btu per SCC Unit: <b>N/A</b>
10. Segment Comment:		

**Segment Description and Rate:** Segment of

1. Segment Description (Process/Fuel Type):		
2. Source Classification Code (SCC):		3. SCC Units:
4. Maximum Hourly Rate:	5. Maximum Annual Rate:	6. Estimated Annual Activity Factor:
7. Maximum % Sulfur:	8. Maximum % Ash:	9. Million Btu per SCC Unit:
10. Segment Comment:		



**EMISSIONS UNIT INFORMATION**  
 Section [ 7 ] of [ 10 ]

**E. EMISSIONS UNIT POLLUTANTS**

**List of Pollutants Emitted by Emissions Unit**

1. Pollutant Emitted	2. Primary Control Device Code	3. Secondary Control Device Code	4. Pollutant Regulatory Code
1 – PM	018, 054, 061, 062, 106, and 108		NS
2 – PM10	018, 054, 061, 062, 106, and 108		NS

**F1. EMISSIONS UNIT POLLUTANT DETAIL INFORMATION –  
POTENTIAL, FUGITIVE, AND ACTUAL EMISSIONS**

(Optional for unregulated emissions units.)

**Potential, Estimated Fugitive, and Baseline & Projected Actual Emissions**

**Complete for each pollutant identified in Subsection E if applying for an air construction permit or concurrent processing of an air construction permit and a revised or renewal Title V permit. Complete for each emissions-limited pollutant identified in Subsection E if applying for an air operation permit.**

1. Pollutant Emitted: <b>PM</b>		2. Total Percent Efficiency of Control: <b>N/A</b>	
3. Potential Emissions: <b>2.0 lb/hour</b> <b>2.5 tons/year</b>		4. Synthetically Limited? <input type="checkbox"/> Yes <input checked="" type="checkbox"/> No	
5. Range of Estimated Fugitive Emissions (as applicable): <b>N/A</b> to tons/year			
6. Emission Factor: <b>N/A</b> Reference: <b>AP-42, ECT, 2007.</b>		7. Emissions Method Code: <b>3</b>	
8.a. Baseline Actual Emissions (if required): <b>N/A tons/year</b>		8.b. Baseline 24-month Period: <b>N/A</b> From:                      To:	
9.a. Projected Actual Emissions (if required): <b>N/A tons/year</b>		9.b. Projected Monitoring Period: <b>N/A</b> <input type="checkbox"/> 5 years <input type="checkbox"/> 10 years	
10. Calculation of Emissions:  <b>Detailed emission calculations are provided in Appendix A.</b>			
11. Potential, Fugitive, and Actual Emissions Comment:			

**F2. EMISSIONS UNIT POLLUTANT DETAIL INFORMATION -  
ALLOWABLE EMISSIONS**

Complete if the pollutant identified in Subsection F1 is or would be subject to a numerical emissions limitation.

**Allowable Emissions** Allowable Emissions  1  of  1

1. Basis for Allowable Emissions Code: <b>RULE (BACT)</b>	2. Future Effective Date of Allowable Emissions: N/A
3. Allowable Emissions and Units: <b>Best Management Practices (BMPs)</b>	4. Equivalent Allowable Emissions: N/A lb/hour      N/A tons/year
5. Method of Compliance: <b>Implementation of BMPs to control fugitive and non-fugitive PM from material handling and storage systems.</b>	
6. Allowable Emissions Comment (Description of Operating Method):  <b>Rule 62-212.400(4)(c), F.A.C.</b>	

**Allowable Emissions** Allowable Emissions    of

1. Basis for Allowable Emissions Code:	2. Future Effective Date of Allowable Emissions:
3. Allowable Emissions and Units:	4. Equivalent Allowable Emissions: lb/hour      tons/year
5. Method of Compliance:	
6. Allowable Emissions Comment (Description of Operating Method):	

**F1. EMISSIONS UNIT POLLUTANT DETAIL INFORMATION –  
POTENTIAL, FUGITIVE, AND ACTUAL EMISSIONS**

(Optional for unregulated emissions units.)

**Potential, Estimated Fugitive, and Baseline & Projected Actual Emissions**

Complete for each pollutant identified in Subsection E if applying for an air construction permit or concurrent processing of an air construction permit and a revised or renewal Title V permit. Complete for each emissions-limited pollutant identified in Subsection E if applying for an air operation permit.

1. Pollutant Emitted: <b>PM10</b>		2. Total Percent Efficiency of Control: <b>N/A</b>	
3. Potential Emissions: <b>1.0 lb/hour</b> <b>1.3 tons/year</b>		4. Synthetically Limited? <input type="checkbox"/> Yes <input checked="" type="checkbox"/> No	
5. Range of Estimated Fugitive Emissions (as applicable): <b>N/A</b> to tons/year			
6. Emission Factor: <b>N/A</b> Reference: <b>AP-42, ECT, 2007.</b>		7. Emissions Method Code: <b>3</b>	
8.a. Baseline Actual Emissions (if required): <b>N/A tons/year</b>		8.b. Baseline 24-month Period: <b>N/A</b> From:                      To:	
9.a. Projected Actual Emissions (if required): <b>N/A tons/year</b>		9.b. Projected Monitoring Period: <b>N/A</b> <input type="checkbox"/> 5 years <input type="checkbox"/> 10 years	
10. Calculation of Emissions:  <b>Detailed emission calculations are provided in Appendix A.</b>			
11. Potential, Fugitive, and Actual Emissions Comment:			

**F2. EMISSIONS UNIT POLLUTANT DETAIL INFORMATION -  
ALLOWABLE EMISSIONS**

Complete if the pollutant identified in Subsection F1 is or would be subject to a numerical emissions limitation.

**Allowable Emissions** Allowable Emissions 1 of 1

1. Basis for Allowable Emissions Code: <b>RULE (BACT)</b>	2. Future Effective Date of Allowable Emissions: N/A
3. Allowable Emissions and Units: <b>Best Management Practices (BMPs)</b>	4. Equivalent Allowable Emissions: N/A lb/hour      N/A tons/year
5. Method of Compliance: <b>Implementation of BMPs to control fugitive and non-fugitive PM<sub>10</sub> from material handling and storage systems.</b>	
6. Allowable Emissions Comment (Description of Operating Method):  <b>Rule 62-212.400(4)(c), F.A.C.</b>	

**Allowable Emissions** Allowable Emissions of

1. Basis for Allowable Emissions Code:	2. Future Effective Date of Allowable Emissions:
3. Allowable Emissions and Units:	4. Equivalent Allowable Emissions: lb/hour      tons/year
5. Method of Compliance:	
6. Allowable Emissions Comment (Description of Operating Method):	

**EMISSIONS UNIT INFORMATION**

Section [ 7 ] of [ 10 ]

**G. VISIBLE EMISSIONS INFORMATION**

**Complete if this emissions unit is or would be subject to a unit-specific visible emissions limitation.**

**Visible Emissions Limitation:** Visible Emissions Limitation  1  of  1

1. Visible Emissions Subtype: <b>VE20</b>	2. Basis for Allowable Opacity: <input checked="" type="checkbox"/> Rule <input type="checkbox"/> Other
3. Allowable Opacity: Normal Conditions: <b>20 %</b> Exceptional Conditions: % Maximum Period of Excess Opacity Allowed: min/hour	
4. Method of Compliance: <b>EPA Reference Method 9</b>	
5. Visible Emissions Comment:  <b>Rule 62-296.320(4)(b), F.A.C.</b>  <b>NSPS Subpart Y – Coal Handling and Storage.</b>	

**Visible Emissions Limitation:** Visible Emissions Limitation of

1. Visible Emissions Subtype:	2. Basis for Allowable Opacity: <input type="checkbox"/> Rule <input type="checkbox"/> Other
3. Allowable Opacity: Normal Conditions: % Exceptional Conditions: % Maximum Period of Excess Opacity Allowed: min/hour	
4. Method of Compliance:	
5. Visible Emissions Comment:	

**EMISSIONS UNIT INFORMATION**

Section [ 7 ] of [ 10 ]

**H. CONTINUOUS MONITOR INFORMATION** **NOT APPLICABLE**

**Complete if this emissions unit is or would be subject to continuous monitoring.**

**Continuous Monitoring System:** Continuous Monitor of

1. Parameter Code:	2. Pollutant(s):
3. CMS Requirement:	<input type="checkbox"/> Rule <input type="checkbox"/> Other
4. Monitor Information Manufacturer: Model Number: <span style="float: right;">Serial Number:</span>	
5. Installation Date:	6. Performance Specification Test Date:
7. Continuous Monitor Comment:	

**Continuous Monitoring System:** Continuous Monitor of

1. Parameter Code:	2. Pollutant(s):
3. CMS Requirement:	<input type="checkbox"/> Rule <input type="checkbox"/> Other
4. Monitor Information Manufacturer: Model Number: <span style="float: right;">Serial Number:</span>	
5. Installation Date:	6. Performance Specification Test Date:
7. Continuous Monitor Comment:	

**EMISSIONS UNIT INFORMATION**

Section [ 7 ] of [ 10 ]

**I. EMISSIONS UNIT ADDITIONAL INFORMATION**

**Additional Requirements for All Applications, Except as Otherwise Stated**

1. Process Flow Diagram (Required for all permit applications, except Title V air operation permit revision applications if this information was submitted to the department within the previous five years and would not be altered as a result of the revision being sought) <input checked="" type="checkbox"/> Attached, Document ID: <u>Fig. 2-4</u> <input type="checkbox"/> Previously Submitted, Date _____
2. Fuel Analysis or Specification (Required for all permit applications, except Title V air operation permit revision applications if this information was submitted to the department within the previous five years and would not be altered as a result of the revision being sought) <input type="checkbox"/> Attached, Document ID: _____ <input checked="" type="checkbox"/> Not Applicable
3. Detailed Description of Control Equipment (Required for all permit applications, except Title V air operation permit revision applications if this information was submitted to the department within the previous five years and would not be altered as a result of the revision being sought) <input checked="" type="checkbox"/> Attached, Document ID: <u>Section 2.0</u> <input type="checkbox"/> Previously Submitted, Date _____
4. Procedures for Startup and Shutdown (Required for all operation permit applications, except Title V air operation permit revision applications if this information was submitted to the department within the previous five years and would not be altered as a result of the revision being sought) <input checked="" type="checkbox"/> Not Applicable (construction application)
5. Operation and Maintenance Plan (Required for all permit applications, except Title V air operation permit revision applications if this information was submitted to the department within the previous five years and would not be altered as a result of the revision being sought) <input type="checkbox"/> Attached, Document ID: _____ <input type="checkbox"/> Previously Submitted, Date _____ <input checked="" type="checkbox"/> Not Applicable
6. Compliance Demonstration Reports/Records <input type="checkbox"/> Attached, Document ID: _____ Test Date(s)/Pollutant(s) Tested: _____ _____ <input type="checkbox"/> Previously Submitted, Date: _____ Test Date(s)/Pollutant(s) Tested: _____ _____ <input type="checkbox"/> To be Submitted, Date (if known): _____ Test Date(s)/Pollutant(s) Tested: _____ _____ <input checked="" type="checkbox"/> Not Applicable  Note: For FESOP applications, all required compliance demonstration records/reports must be submitted at the time of application. For Title V air operation permit applications, all required compliance demonstration reports/records must be submitted at the time of application, or a compliance plan must be submitted at the time of application.
7. Other Information Required by Rule or Statute <input type="checkbox"/> Attached, Document ID: _____ <input checked="" type="checkbox"/> Not Applicable



**EMISSIONS UNIT INFORMATION**

Section [ 7 ] of [ 10 ]

**Additional Requirements for Air Construction Permit Applications**

1. Control Technology Review and Analysis (Rules 62-212.400(10) and 62-212.500(7), F.A.C.; 40 CFR 63.43(d) and (e)) <input checked="" type="checkbox"/> Attached, Document ID: <u>Section 5.0</u> <input type="checkbox"/> Not Applicable
2. Good Engineering Practice Stack Height Analysis (Rule 62-212.400(4)(d), F.A.C., and Rule 62-212.500(4)(f), F.A.C.) <input checked="" type="checkbox"/> Attached, Document ID: <u>Section 6.0</u> <input type="checkbox"/> Not Applicable
3. Description of Stack Sampling Facilities (Required for proposed new stack sampling facilities only) <input type="checkbox"/> Attached, Document ID: _____ <input checked="" type="checkbox"/> Not Applicable

**Additional Requirements for Title V Air Operation Permit Applications** **NOT APPLICABLE**

1. Identification of Applicable Requirements <input type="checkbox"/> Attached, Document ID: _____
2. Compliance Assurance Monitoring <input type="checkbox"/> Attached, Document ID: _____ <input type="checkbox"/> Not Applicable
3. Alternative Methods of Operation <input type="checkbox"/> Attached, Document ID: _____ <input type="checkbox"/> Not Applicable
4. Alternative Modes of Operation (Emissions Trading) <input type="checkbox"/> Attached, Document ID: _____ <input type="checkbox"/> Not Applicable
5. Acid Rain Part Application <input type="checkbox"/> Certificate of Representation (EPA Form No. 7610-1) <input type="checkbox"/> Copy Attached, Document ID: _____ <input type="checkbox"/> Acid Rain Part (Form No. 62-210.900(1)(a)) <input type="checkbox"/> Attached, Document ID: _____ <input type="checkbox"/> Previously Submitted, Date: _____ <input type="checkbox"/> Repowering Extension Plan (Form No. 62-210.900(1)(a)1.) <input type="checkbox"/> Attached, Document ID: _____ <input type="checkbox"/> Previously Submitted, Date: _____ <input type="checkbox"/> New Unit Exemption (Form No. 62-210.900(1)(a)2.) <input type="checkbox"/> Attached, Document ID: _____ <input type="checkbox"/> Previously Submitted, Date: _____ <input type="checkbox"/> Retired Unit Exemption (Form No. 62-210.900(1)(a)3.) <input type="checkbox"/> Attached, Document ID: _____ <input type="checkbox"/> Previously Submitted, Date: _____ <input type="checkbox"/> Phase II NOx Compliance Plan (Form No. 62-210.900(1)(a)4.) <input type="checkbox"/> Attached, Document ID: _____ <input type="checkbox"/> Previously Submitted, Date: _____ <input type="checkbox"/> Phase II NOx Averaging Plan (Form No. 62-210.900(1)(a)5.) <input type="checkbox"/> Attached, Document ID: _____ <input type="checkbox"/> Previously Submitted, Date: _____ <input type="checkbox"/> Not Applicable

**EMISSIONS UNIT INFORMATION**

**Section [ 7 ] of [ 10 ]**

**Additional Requirements Comment**

[Empty rectangular box for comment]

**EMISSION EMISSIONS UNIT INFORMATION**

Section | 8 | of | 10 |

**A. GENERAL EMISSIONS UNIT INFORMATION**

**Title V Air Operation Permit Emissions Unit Classification**

1. Regulated or Unregulated Emissions Unit? (Check one, if applying for an initial, revised or renewal Title V air operation permit. Skip this item if applying for an air construction permit or FESOP only.)

The emissions unit addressed in this Emissions Unit Information Section is a regulated emissions unit.

The emissions unit addressed in this Emissions Unit Information Section is an unregulated emissions unit.

**Emissions Unit Description and Status**

1. Type of Emissions Unit Addressed in this Section: (Check one)

This Emissions Unit Information Section addresses, as a single emissions unit, a single process or production unit, or activity, which produces one or more air pollutants and which has at least one definable emission point (stack or vent).

This Emissions Unit Information Section addresses, as a single emissions unit, a group of process or production units and activities which has at least one definable emission point (stack or vent) but may also produce fugitive emissions.

This Emissions Unit Information Section addresses, as a single emissions unit, one or more process or production units and activities which produce fugitive emissions only.

2. Description of Emissions Unit Addressed in this Section:  
**Emergency generator diesel engine fired with ultra low sulfur diesel (ULSD) fuel oil.**

3. Emissions Unit Identification Number: **018 (Unit 6 Emergency Generator Diesel Engine)**

4. Emissions Unit Status Code: <b>C</b>	5. Commence Construction Date: <b>N/A</b>	6. Initial Startup Date: <b>N/A</b>	7. Emissions Unit Major Group SIC Code: <b>49</b>	8. Acid Rain Unit? <input type="checkbox"/> Yes <input checked="" type="checkbox"/> No
--	--	--	--	--

9. Package Unit:  
Manufacturer: \_\_\_\_\_ Model Number: \_\_\_\_\_

10. Generator Nameplate Rating: **1.64 MW**

11. Emissions Unit Comment:

**EMISSIONS UNIT INFORMATION**

Section [ 8 ] of [ 10 ]

**Emissions Unit Control Equipment**

1. Control Equipment/Method(s) Description:

**NO<sub>x</sub> and CO**

**Diesel engine design**

**PM, PM<sub>10</sub>, SO<sub>2</sub>, and H<sub>2</sub>SO<sub>4</sub> Mist**

**Ultra Low Sulfur Diesel (ULSD) Fuel Oil**

2. Control Device or Method Code(s):

**EMISSIONS UNIT INFORMATION**

Section [ 8 ] of [ 10 ]

**B. EMISSIONS UNIT CAPACITY INFORMATION**

(Optional for unregulated emissions units.)

**Emissions Unit Operating Capacity and Schedule**

1. Maximum Process or Throughput Rate: N/A
2. Maximum Production Rate: N/A
3. Maximum Heat Input Rate: <b>15.4</b> million Btu/hr
4. Maximum Incineration Rate: N/A pounds/hr tons/day
5. Requested Maximum Operating Schedule: hours/day days/week weeks/year <b>100</b> hours/year
6. Operating Capacity/Schedule Comment:  <b>Excluding operations during emergency conditions, the emergency generator diesel engine will operate up to 100 hours per year for routine testing and maintenance.</b>

**EMISSIONS UNIT INFORMATION**

Section | 8 | of | 10 |

**C. EMISSION POINT (STACK/VENT) INFORMATION**  
 (Optional for unregulated emissions units.)

**Emission Point Description and Type**

1. Identification of Point on Plot Plan or Flow Diagram: <b>Unit 6 Emergency Generator Engine</b>		2. Emission Point Type Code: <b>1</b>	
3. Descriptions of Emission Points Comprising this Emissions Unit for VE Tracking:  N/A			
4. ID Numbers or Descriptions of Emission Units with this Emission Point in Common:  N/A			
5. Discharge Type Code: <b>V</b>	6. Stack Height: <b>18 feet</b>	7. Exit Diameter: <b>0.8 feet</b>	
8. Exit Temperature: <b>800 °F</b>	9. Actual Volumetric Flow Rate: <b>10,600 acfm</b>	10. Water Vapor: <b>N/A %</b>	
11. Maximum Dry Standard Flow Rate: <b>N/A dscfm</b>		12. Nonstack Emission Point Height: <b>N/A feet</b>	
13. Emission Point UTM Coordinates Zone: East (km): <b>N/A</b> North (km): <b>N/A</b>		14. Emission Point Latitude/Longitude <b>N/A</b> Latitude (DD/MM/SS) <b>N/A</b> Longitude (DD/MM/SS)	
15. Emission Point Comment:			

**EMISSIONS UNIT INFORMATION**

Section [ 8 ] of [ 10 ]

**D. SEGMENT (PROCESS/FUEL) INFORMATION**

**Segment Description and Rate:** Segment **1** of **1**

1. Segment Description (Process/Fuel Type):  <b>Emergency generator diesel engine fired with distillate fuel oil</b>		
2. Source Classification Code (SCC): <b>2-01-001-02</b>		3. SCC Units: <b>Thousand Gallons Burned</b>
4. Maximum Hourly Rate: <b>0.11</b>	5. Maximum Annual Rate: <b>11.5</b>	6. Estimated Annual Activity Factor:
7. Maximum % Sulfur: <b>0.0015</b>	8. Maximum % Ash: <b>0.01</b>	9. Million Btu per SCC Unit: <b>134</b>
10. Segment Comment:  <b>Fuel flow estimated based on engine rating of 2,200 hp and assumed heat rate of 7,000 Btu/hp-hr.</b>		

**Segment Description and Rate:** Segment of

1. Segment Description (Process/Fuel Type):		
2. Source Classification Code (SCC):		3. SCC Units:
4. Maximum Hourly Rate:	5. Maximum Annual Rate:	6. Estimated Annual Activity Factor:
7. Maximum % Sulfur:	8. Maximum % Ash:	9. Million Btu per SCC Unit:
10. Segment Comment:		

**EMISSIONS UNIT INFORMATION**  
 Section [ 8 ] of [ 10 ]

**E. EMISSIONS UNIT POLLUTANTS**

**List of Pollutants Emitted by Emissions Unit**

1. Pollutant Emitted	2. Primary Control Device Code	3. Secondary Control Device Code	4. Pollutant Regulatory Code
<b>1 – NOX</b>			<b>EL</b>
<b>2 – SO2</b>			<b>EL</b>
<b>3 – PM</b>			<b>EL</b>
<b>4 – PM10</b>			<b>EL</b>
<b>5 – CO</b>			<b>EL</b>
<b>6 – VOC</b>			<b>NS</b>
<b>7 – SAM</b>			<b>WP</b>



**F1. EMISSIONS UNIT POLLUTANT DETAIL INFORMATION –  
POTENTIAL, FUGITIVE, AND ACTUAL EMISSIONS**

(Optional for unregulated emissions units.)

**Potential, Estimated Fugitive, and Baseline & Projected Actual Emissions**

**Complete for each pollutant identified in Subsection E if applying for an air construction permit or concurrent processing of an air construction permit and a revised or renewal Title V permit. Complete for each emissions-limited pollutant identified in Subsection E if applying for an air operation permit.**

1. Pollutant Emitted: <b>NOX</b>		2. Total Percent Efficiency of Control:	
3. Potential Emissions: <b>23.1 lb/hour</b> <b>1.2 tons/year</b>		4. Synthetically Limited? <input checked="" type="checkbox"/> Yes <input type="checkbox"/> No	
5. Range of Estimated Fugitive Emissions (as applicable): <b>N/A</b> to tons/year			
6. Emission Factor: <b>6.4 grams per kilowatt-hour (g/kWh)</b> Reference: <b>NSPS Subpart III.</b>		7. Emissions Method Code: <b>0</b>	
8.a. Baseline Actual Emissions (if required): <b>N/A tons/year</b>		8.b. Baseline 24-month Period: <b>N/A</b> From:                      To:	
9.a. Projected Actual Emissions (if required): <b>N/A tons/year</b>		9.b. Projected Monitoring Period: <b>N/A</b> <input type="checkbox"/> 5 years <input type="checkbox"/> 10 years	
10. Calculation of Emissions:  <b>Detailed emission calculations are provided in Appendix A.</b>			
11. Potential, Fugitive, and Actual Emissions Comment:  <b>Excluding operations during emergency conditions, the emergency generator diesel engine will operate up to 100 hours per year for routine testing and maintenance.</b>			

**F2. EMISSIONS UNIT POLLUTANT DETAIL INFORMATION -  
ALLOWABLE EMISSIONS**

Complete if the pollutant identified in Subsection F1 is or would be subject to a numerical emissions limitation.

**Allowable Emissions** Allowable Emissions  1  of  1

1. Basis for Allowable Emissions Code: <b>RULE (BACT)</b>	2. Future Effective Date of Allowable Emissions: <b>N/A</b>
3. Allowable Emissions and Units: <b>6.4 g/kWh</b>	4. Equivalent Allowable Emissions: <b>23.1 lb/hour      1.2 tons/year</b>
5. Method of Compliance: <b>Engine manufacturer certification per NSPS Subpart III.</b>	
6. Allowable Emissions Comment (Description of Operating Method): <b>Limit in Field 3 is for NO<sub>x</sub> + NMHC per NSPS Subpart III. Rule 62-212.400(4)(c), F.A.C.</b>	

**Allowable Emissions** Allowable Emissions    of

1. Basis for Allowable Emissions Code:	2. Future Effective Date of Allowable Emissions:
3. Allowable Emissions and Units:	4. Equivalent Allowable Emissions: lb/hour      tons/year
5. Method of Compliance:	
6. Allowable Emissions Comment (Description of Operating Method):	
6. Allowable Emissions Comment (Description of Operating Method):	

F1. EMISSIONS UNIT POLLUTANT DETAIL INFORMATION –  
POTENTIAL, FUGITIVE, AND ACTUAL EMISSIONS

(Optional for unregulated emissions units.)

**Potential, Estimated Fugitive, and Baseline & Projected Actual Emissions**

Complete for each pollutant identified in Subsection E if applying for an air construction permit or concurrent processing of an air construction permit and a revised or renewal Title V permit. Complete for each emissions-limited pollutant identified in Subsection E if applying for an air operation permit.

1. Pollutant Emitted: <b>SO2</b>	2. Total Percent Efficiency of Control:
3. Potential Emissions: <b>0.03</b> lb/hour <b>0.0013</b> tons/year	4. Synthetically Limited? <input checked="" type="checkbox"/> Yes <input type="checkbox"/> No
5. Range of Estimated Fugitive Emissions (as applicable): <b>N/A</b> to tons/year	
6. Emission Factor: <b>0.0074 g/kWh</b>  Reference: <b>AP-42.</b>	7. Emissions Method Code: <b>3</b>
8.a. Baseline Actual Emissions (if required): <b>N/A</b> tons/year	8.b. Baseline 24-month Period: <b>N/A</b> From:                                        To:
9.a. Projected Actual Emissions (if required): <b>N/A</b> tons/year	9.b. Projected Monitoring Period: <b>N/A</b> <input type="checkbox"/> 5 years <input type="checkbox"/> 10 years
10. Calculation of Emissions:  <b>Detailed emission calculations are provided in Appendix A.</b>	
11. Potential, Fugitive, and Actual Emissions Comment:  <b>Excluding operations during emergency conditions, the emergency generator diesel engine will operate up to 100 hours per year for routine testing and maintenance.</b>	

**F2. EMISSIONS UNIT POLLUTANT DETAIL INFORMATION -  
ALLOWABLE EMISSIONS**

Complete if the pollutant identified in Subsection F1 is or would be subject to a numerical emissions limitation.

**Allowable Emissions** Allowable Emissions 1 of 1

1. Basis for Allowable Emissions Code: <b>RULE (BACT)</b>	2. Future Effective Date of Allowable Emissions: <b>N/A</b>
3. Allowable Emissions and Units: <b>0.0015 % S fuel oil</b>	4. Equivalent Allowable Emissions: <b>0.03 lb/hour 0.0013 tons/year</b>
5. Method of Compliance: <b>Fuel oil analysis for sulfur content.</b>	
6. Allowable Emissions Comment (Description of Operating Method): <b>Rule 62-212.400(4)(c), F.A.C.</b>	

**Allowable Emissions** Allowable Emissions of

1. Basis for Allowable Emissions Code:	2. Future Effective Date of Allowable Emissions:
3. Allowable Emissions and Units:	4. Equivalent Allowable Emissions: lb/hour tons/year
5. Method of Compliance:	
6. Allowable Emissions Comment (Description of Operating Method):	

**Allowable Emissions** Allowable Emissions of

1. Basis for Allowable Emissions Code:	2. Future Effective Date of Allowable Emissions:
3. Allowable Emissions and Units:	4. Equivalent Allowable Emissions: lb/hour tons/year
5. Method of Compliance:	
6. Allowable Emissions Comment (Description of Operating Method):	

**F1. EMISSIONS UNIT POLLUTANT DETAIL INFORMATION –  
POTENTIAL, FUGITIVE, AND ACTUAL EMISSIONS**

**(Optional for unregulated emissions units.)**

**Potential, Estimated Fugitive, and Baseline & Projected Actual Emissions**

**Complete for each pollutant identified in Subsection E if applying for an air construction permit or concurrent processing of an air construction permit and a revised or renewal Title V permit. Complete for each emissions-limited pollutant identified in Subsection E if applying for an air operation permit.**

1. Pollutant Emitted: <b>PM/PM10</b>		2. Total Percent Efficiency of Control:	
3. Potential Emissions: <b>0.7 lb/hour                      0.04 tons/year</b>		4. Synthetically Limited? <input checked="" type="checkbox"/> Yes <input type="checkbox"/> No	
5. Range of Estimated Fugitive Emissions (as applicable): <b>N/A</b> to tons/year			
6. Emission Factor: <b>0.20 g/kWh</b>  Reference: <b>NSPS Subpart III.</b>		7. Emissions Method Code: <b>0</b>	
8.a. Baseline Actual Emissions (if required): <b>N/A tons/year</b>		8.b. Baseline 24-month Period: <b>N/A</b> From:                      To:	
9.a. Projected Actual Emissions (if required): <b>N/A tons/year</b>		9.b. Projected Monitoring Period: <b>N/A</b> <input type="checkbox"/> 5 years <input type="checkbox"/> 10 years	
10. Calculation of Emissions:  <b>Detailed emission calculations are provided in Appendix A.</b>			
11. Potential, Fugitive, and Actual Emissions Comment:  <b>Excluding operations during emergency conditions, the emergency generator diesel engine will operate up to 100 hours per year for routine testing and maintenance.</b>			

**F2. EMISSIONS UNIT POLLUTANT DETAIL INFORMATION -  
ALLOWABLE EMISSIONS**

Complete if the pollutant identified in Subsection F1 is or would be subject to a numerical emissions limitation.

Allowable Emissions Allowable Emissions  1  of  1

1. Basis for Allowable Emissions Code: <b>RULE (BACT)</b>	2. Future Effective Date of Allowable Emissions: <b>N/A</b>
3. Allowable Emissions and Units: <b>0.20 g/kWh</b>	4. Equivalent Allowable Emissions: <b>0.7 lb/hour      0.04 tons/year</b>
5. Method of Compliance: <b>Engine manufacturer certification per NSPS Subpart III.</b>	
6. Allowable Emissions Comment (Description of Operating Method):  <b>Rule 62-212.400(4)(c), F.A.C.</b>	

Allowable Emissions Allowable Emissions    of

1. Basis for Allowable Emissions Code:	2. Future Effective Date of Allowable Emissions:
3. Allowable Emissions and Units:	4. Equivalent Allowable Emissions: <b>lb/hour      tons/year</b>
5. Method of Compliance:	
6. Allowable Emissions Comment (Description of Operating Method):	

Allowable Emissions Allowable Emissions    of

1. Basis for Allowable Emissions Code:	2. Future Effective Date of Allowable Emissions:
3. Allowable Emissions and Units:	4. Equivalent Allowable Emissions: <b>lb/hour      tons/year</b>
5. Method of Compliance:	
6. Allowable Emissions Comment (Description of Operating Method):	

**F1. EMISSIONS UNIT POLLUTANT DETAIL INFORMATION –  
POTENTIAL, FUGITIVE, AND ACTUAL EMISSIONS**

(Optional for unregulated emissions units.)

**Potential, Estimated Fugitive, and Baseline & Projected Actual Emissions**

**Complete for each pollutant identified in Subsection E if applying for an air construction permit or concurrent processing of an air construction permit and a revised or renewal Title V permit. Complete for each emissions-limited pollutant identified in Subsection E if applying for an air operation permit.**

1. Pollutant Emitted: <b>CO</b>		2. Total Percent Efficiency of Control:	
3. Potential Emissions: <b>12.7 lb/hour</b> <b>0.6 tons/year</b>		4. Synthetically Limited? <input checked="" type="checkbox"/> Yes <input type="checkbox"/> No	
5. Range of Estimated Fugitive Emissions (as applicable): <b>N/A</b> to tons/year			
6. Emission Factor: <b>3.5 g/kWh</b>  Reference: <b>NSPS Subpart IIII.</b>		7. Emissions Method Code: <b>0</b>	
8.a. Baseline Actual Emissions (if required): <b>N/A tons/year</b>		8.b. Baseline 24-month Period: <b>N/A</b> From:                      To:	
9.a. Projected Actual Emissions (if required): <b>N/A tons/year</b>		9.b. Projected Monitoring Period: <b>N/A</b> <input type="checkbox"/> 5 years <input type="checkbox"/> 10 years	
10. Calculation of Emissions:  <b>Detailed emission calculations are provided in Appendix A.</b>			
11. Potential, Fugitive, and Actual Emissions Comment:  <b>Excluding operations during emergency conditions, the emergency generator diesel engine will operate up to 100 hours per year for routine testing and maintenance.</b>			

**F2. EMISSIONS UNIT POLLUTANT DETAIL INFORMATION -  
 ALLOWABLE EMISSIONS**

**Complete if the pollutant identified in Subsection F1 is or would be subject to a numerical emissions limitation.**

**Allowable Emissions** Allowable Emissions 1 of 1

1. Basis for Allowable Emissions Code: <b>RULE (BACT)</b>	2. Future Effective Date of Allowable Emissions: <b>N/A</b>
3. Allowable Emissions and Units: <b>3.5 g/kWh</b>	4. Equivalent Allowable Emissions: <b>12.7 lb/hour      0.6 tons/year</b>
5. Method of Compliance: <b>Engine manufacturer certification per NSPS Subpart III.</b>	
6. Allowable Emissions Comment (Description of Operating Method):  <b>Rule 62-212.400(4)(c), F.A.C.</b>	

**Allowable Emissions** Allowable Emissions    of

1. Basis for Allowable Emissions Code:	2. Future Effective Date of Allowable Emissions:
3. Allowable Emissions and Units:	4. Equivalent Allowable Emissions: lb/hour      tons/year
5. Method of Compliance:	
6. Allowable Emissions Comment (Description of Operating Method):	

**Allowable Emissions** Allowable Emissions    of

1. Basis for Allowable Emissions Code:	2. Future Effective Date of Allowable Emissions:
3. Allowable Emissions and Units:	4. Equivalent Allowable Emissions: lb/hour      tons/year
5. Method of Compliance:	
6. Allowable Emissions Comment (Description of Operating Method):	



**F1. EMISSIONS UNIT POLLUTANT DETAIL INFORMATION –  
POTENTIAL, FUGITIVE, AND ACTUAL EMISSIONS**

(Optional for unregulated emissions units.)

**Potential, Estimated Fugitive, and Baseline & Projected Actual Emissions**

**Complete for each pollutant identified in Subsection E if applying for an air construction permit or concurrent processing of an air construction permit and a revised or renewal Title V permit. Complete for each emissions-limited pollutant identified in Subsection E if applying for an air operation permit.**

1. Pollutant Emitted: <b>VOC</b>		2. Total Percent Efficiency of Control:	
3. Potential Emissions: <b>1.6 lb/hour</b> <b>0.08 tons/year</b>		4. Synthetically Limited? <input checked="" type="checkbox"/> Yes <input type="checkbox"/> No	
5. Range of Estimated Fugitive Emissions (as applicable): <b>N/A</b> to tons/year			
6. Emission Factor: <b>0.4 g/kWh</b>  Reference: <b>AP-42.</b>		7. Emissions Method Code: <b>3</b>	
8.a. Baseline Actual Emissions (if required): <b>N/A tons/year</b>		8.b. Baseline 24-month Period: <b>N/A</b> From:                                      To:	
9.a. Projected Actual Emissions (if required): <b>N/A tons/year</b>		9.b. Projected Monitoring Period: <b>N/A</b> <input type="checkbox"/> 5 years <input type="checkbox"/> 10 years	
10. Calculation of Emissions:  <b>Detailed emission calculations are provided in Appendix A.</b>			
11. Potential, Fugitive, and Actual Emissions Comment:  <b>Excluding operations during emergency conditions, the emergency generator diesel engine will operate up to 96 hours per year for routine testing and maintenance.</b>			

**F2. EMISSIONS UNIT POLLUTANT DETAIL INFORMATION -  
ALLOWABLE EMISSIONS N/A**

Complete if the pollutant identified in Subsection F1 is or would be subject to a numerical emissions limitation.

**Allowable Emissions** Allowable Emissions of

1. Basis for Allowable Emissions Code:	2. Future Effective Date of Allowable Emissions:
3. Allowable Emissions and Units:	4. Equivalent Allowable Emissions: lb/hour                      tons/year
5. Method of Compliance:	
6. Allowable Emissions Comment (Description of Operating Method):	

**Allowable Emissions** Allowable Emissions of

1. Basis for Allowable Emissions Code:	2. Future Effective Date of Allowable Emissions:
3. Allowable Emissions and Units:	4. Equivalent Allowable Emissions: lb/hour                      tons/year
5. Method of Compliance:	
6. Allowable Emissions Comment (Description of Operating Method):	

**Allowable Emissions** Allowable Emissions of

1. Basis for Allowable Emissions Code:	2. Future Effective Date of Allowable Emissions:
3. Allowable Emissions and Units:	4. Equivalent Allowable Emissions: lb/hour                      tons/year
5. Method of Compliance:	
6. Allowable Emissions Comment (Description of Operating Method):	

**F1. EMISSIONS UNIT POLLUTANT DETAIL INFORMATION –  
POTENTIAL, FUGITIVE, AND ACTUAL EMISSIONS**

**(Optional for unregulated emissions units.)**

**Potential, Estimated Fugitive, and Baseline & Projected Actual Emissions**

**Complete for each pollutant identified in Subsection E if applying for an air construction permit or concurrent processing of an air construction permit and a revised or renewal Title V permit. Complete for each emissions-limited pollutant identified in Subsection E if applying for an air operation permit.**

1. Pollutant Emitted: <b>SAM</b>		2. Total Percent Efficiency of Control:	
3. Potential Emissions: Neg. lb/hour                      Neg. tons/year		4. Synthetically Limited? <input checked="" type="checkbox"/> Yes <input type="checkbox"/> No	
5. Range of Estimated Fugitive Emissions (as applicable): <b>N/A</b> to tons/year			
6. Emission Factor: <b>N/A</b>  Reference: <b>ECT, 2007.</b>		7. Emissions Method Code: <b>2</b>	
8.a. Baseline Actual Emissions (if required): <b>N/A</b> tons/year		8.b. Baseline 24-month Period: <b>N/A</b> From:                                      To:	
9.a. Projected Actual Emissions (if required): <b>N/A</b> tons/year		9.b. Projected Monitoring Period: <b>N/A</b> <input type="checkbox"/> 5 years <input type="checkbox"/> 10 years	
10. Calculation of Emissions:  <b>Emergency generator diesel engine sulfuric acid mist emissions resulting from the combustion of ULSD fuel oil will be negligible.</b>			
11. Potential, Fugitive, and Actual Emissions Comment:  <b>Excluding operations during emergency conditions, the emergency generator diesel engine will operate up to 100 hours per year for routine testing and maintenance.</b>			

F2. EMISSIONS UNIT POLLUTANT DETAIL INFORMATION -  
ALLOWABLE EMISSIONS

Complete if the pollutant identified in Subsection F1 is or would be subject to a numerical emissions limitation.

Allowable Emissions Allowable Emissions 1 of 1

1. Basis for Allowable Emissions Code: <b>RULE (BACT)</b>	2. Future Effective Date of Allowable Emissions: <b>N/A</b>
3. Allowable Emissions and Units: <b>0.0015 % S fuel oil</b>	4. Equivalent Allowable Emissions: <b>N/A lb/hour      N/A tons/year</b>
5. Method of Compliance: <b>Fuel oil analysis for sulfur content.</b>	
6. Allowable Emissions Comment (Description of Operating Method):  <b>Rule 62-212.400(4)(c), F.A.C.</b>	

Allowable Emissions Allowable Emissions      of

1. Basis for Allowable Emissions Code:	2. Future Effective Date of Allowable Emissions:
3. Allowable Emissions and Units:	4. Equivalent Allowable Emissions: <b>lb/hour      tons/year</b>
5. Method of Compliance:	
6. Allowable Emissions Comment (Description of Operating Method):	

Allowable Emissions Allowable Emissions      of

1. Basis for Allowable Emissions Code:	2. Future Effective Date of Allowable Emissions:
3. Allowable Emissions and Units:	4. Equivalent Allowable Emissions: <b>lb/hour      tons/year</b>
5. Method of Compliance:	
6. Allowable Emissions Comment (Description of Operating Method):	

**EMISSIONS UNIT INFORMATION**

Section [ 8 ] of [ 10 ]

**G. VISIBLE EMISSIONS INFORMATION**

**Complete if this emissions unit is or would be subject to a unit-specific visible emissions limitation.**

**Visible Emissions Limitation:** Visible Emissions Limitation  1  of  2

1. Visible Emissions Subtype: <b>VE20</b>	2. Basis for Allowable Opacity: <input checked="" type="checkbox"/> Rule <input type="checkbox"/> Other
3. Allowable Opacity: Normal Conditions: <b>20 %</b> Exceptional Conditions:      % Maximum Period of Excess Opacity Allowed:      min/hour	
4. Method of Compliance: <b>EPA Reference Method 9</b>	
5. Visible Emissions Comment:  <b>Rule 62-296.320(4)(b), F.A.C.</b>	

**Visible Emissions Limitation:** Visible Emissions Limitation  2  of  2

1. Visible Emissions Subtype: <b>VE99</b>	2. Basis for Allowable Opacity: <input checked="" type="checkbox"/> Rule <input type="checkbox"/> Other
3. Allowable Opacity: Normal Conditions:      %      Exceptional Conditions:      % Maximum Period of Excess Opacity Allowed: <b>60 min/hour</b>	
4. Method of Compliance: <b>EPA Reference Method 9</b>	
5. Visible Emissions Comment:  <b>Excess emissions resulting from startup, shutdown or malfunction of any emissions unit shall be permitted providing (1) best operational practices to minimize emissions are adhered to and (2) the duration of excess emissions shall be minimized but in no case exceed two hours in any 24 hour period unless specifically authorized by the Department for longer duration.</b>  <b>Rule 62-210.700(1), F.A.C.</b>	

**EMISSIONS UNIT INFORMATION**

Section [ 8 ] of [ 10 ]

**H. CONTINUOUS MONITOR INFORMATION – N/A**

**Complete if this emissions unit is or would be subject to continuous monitoring.**

**Continuous Monitoring System:** Continuous Monitor of

1. Parameter Code:	2. Pollutant(s):
3. CMS Requirement:	<input type="checkbox"/> Rule <input type="checkbox"/> Other
4. Monitor Information Manufacturer: Model Number: Serial Number:	
5. Installation Date:	6. Performance Specification Test Date:
7. Continuous Monitor Comment:	

**Continuous Monitoring System:** Continuous Monitor of

1. Parameter Code:	2. Pollutant(s):
3. CMS Requirement:	<input type="checkbox"/> Rule <input type="checkbox"/> Other
4. Monitor Information Manufacturer: Model Number: Serial Number:	
5. Installation Date:	6. Performance Specification Test Date:
7. Continuous Monitor Comment:	

**EMISSIONS UNIT INFORMATION**

Section [ 8 ] of [ 10 ]

**I. EMISSIONS UNIT ADDITIONAL INFORMATION**

**Additional Requirements for All Applications, Except as Otherwise Stated**

1. Process Flow Diagram (Required for all permit applications, except Title V air operation permit revision applications if this information was submitted to the department within the previous five years and would not be altered as a result of the revision being sought) <input checked="" type="checkbox"/> Attached, Document ID: <b>Fig. 2-4</b> <input type="checkbox"/> Previously Submitted, Date _____
2. Fuel Analysis or Specification (Required for all permit applications, except Title V air operation permit revision applications if this information was submitted to the department within the previous five years and would not be altered as a result of the revision being sought) <input checked="" type="checkbox"/> Attached, Document ID: <b>Section 2.2, Table 2-5</b>
3. Detailed Description of Control Equipment (Required for all permit applications, except Title V air operation permit revision applications if this information was submitted to the department within the previous five years and would not be altered as a result of the revision being sought) <input checked="" type="checkbox"/> Attached, Document ID: <b>Section 2.0</b> <input type="checkbox"/> Previously Submitted, Date _____
4. Procedures for Startup and Shutdown (Required for all operation permit applications, except Title V air operation permit revision applications if this information was submitted to the department within the previous five years and would not be altered as a result of the revision being sought) <input checked="" type="checkbox"/> Not Applicable (construction application)
5. Operation and Maintenance Plan (Required for all permit applications, except Title V air operation permit revision applications if this information was submitted to the department within the previous five years and would not be altered as a result of the revision being sought) <input type="checkbox"/> Attached, Document ID: _____ <input type="checkbox"/> Previously Submitted, Date _____ <input checked="" type="checkbox"/> Not Applicable
6. Compliance Demonstration Reports/Records <input type="checkbox"/> Attached, Document ID: _____ Test Date(s)/Pollutant(s) Tested: _____ <input type="checkbox"/> Previously Submitted, Date: _____ Test Date(s)/Pollutant(s) Tested: _____ <input type="checkbox"/> To be Submitted, Date (if known): _____ Test Date(s)/Pollutant(s) Tested: _____ <input checked="" type="checkbox"/> Not Applicable  Note: For FESOP applications, all required compliance demonstration records/reports must be submitted at the time of application. For Title V air operation permit applications, all required compliance demonstration reports/records must be submitted at the time of application, or a compliance plan must be submitted at the time of application.
7. Other Information Required by Rule or Statute <input type="checkbox"/> Attached, Document ID: _____ <input checked="" type="checkbox"/> Not Applicable

**EMISSIONS UNIT INFORMATION**

Section [ 8 ] of [ 10 ]

**Additional Requirements for Air Construction Permit Applications**

1. Control Technology Review and Analysis (Rules 62-212.400(10) and 62-212.500(7), F.A.C.; 40 CFR 63.43(d) and (e)) <input checked="" type="checkbox"/> Attached, Document ID: <u>Section 5.0</u> <input type="checkbox"/> Not Applicable
2. Good Engineering Practice Stack Height Analysis (Rule 62-212.400(4)(d), F.A.C., and Rule 62-212.500(4)(f), F.A.C.) <input checked="" type="checkbox"/> Attached, Document ID: <u>Section 6.0</u> <input type="checkbox"/> Not Applicable
3. Description of Stack Sampling Facilities (Required for proposed new stack sampling facilities only) <input type="checkbox"/> Attached, Document ID: _____ <input checked="" type="checkbox"/> Not Applicable

**Additional Requirements for Title V Air Operation Permit Applications** **NOT APPLICABLE**

1. Identification of Applicable Requirements <input type="checkbox"/> Attached, Document ID: _____
2. Compliance Assurance Monitoring <input type="checkbox"/> Attached, Document ID: _____ <input type="checkbox"/> Not Applicable
3. Alternative Methods of Operation <input type="checkbox"/> Attached, Document ID: _____ <input type="checkbox"/> Not Applicable
4. Alternative Modes of Operation (Emissions Trading) <input type="checkbox"/> Attached, Document ID: _____ <input type="checkbox"/> Not Applicable
5. Acid Rain Part Application <input type="checkbox"/> Certificate of Representation (EPA Form No. 7610-1) <input type="checkbox"/> Copy Attached, Document ID: _____ <input type="checkbox"/> Acid Rain Part (Form No. 62-210.900(1)(a)) <input type="checkbox"/> Attached, Document ID: _____ <input type="checkbox"/> Previously Submitted, Date: _____ <input type="checkbox"/> Repowering Extension Plan (Form No. 62-210.900(1)(a)1.) <input type="checkbox"/> Attached, Document ID: _____ <input type="checkbox"/> Previously Submitted, Date: _____ <input type="checkbox"/> New Unit Exemption (Form No. 62-210.900(1)(a)2.) <input type="checkbox"/> Attached, Document ID: _____ <input type="checkbox"/> Previously Submitted, Date: _____ <input type="checkbox"/> Retired Unit Exemption (Form No. 62-210.900(1)(a)3.) <input type="checkbox"/> Attached, Document ID: _____ <input type="checkbox"/> Previously Submitted, Date: _____ <input type="checkbox"/> Phase II NOx Compliance Plan (Form No. 62-210.900(1)(a)4.) <input type="checkbox"/> Attached, Document ID: _____ <input type="checkbox"/> Previously Submitted, Date: _____ <input type="checkbox"/> Phase II NOx Averaging Plan (Form No. 62-210.900(1)(a)5.) <input type="checkbox"/> Attached, Document ID: _____ <input type="checkbox"/> Previously Submitted, Date: _____ <input type="checkbox"/> Not Applicable



**EMISSIONS UNIT INFORMATION**

**Section [ 8 ] of [ 10 ]**

**Additional Requirements Comment**

[Empty rectangular box for comment]

**EMISSION EMISSIONS UNIT INFORMATION**

Section | 9 | of | 10 |

**A. GENERAL EMISSIONS UNIT INFORMATION**

**Title V Air Operation Permit Emissions Unit Classification**

1. Regulated or Unregulated Emissions Unit? (Check one, if applying for an initial, revised or renewal Title V air operation permit. Skip this item if applying for an air construction permit or FESOP only.)

The emissions unit addressed in this Emissions Unit Information Section is a regulated emissions unit.

The emissions unit addressed in this Emissions Unit Information Section is an unregulated emissions unit.

**Emissions Unit Description and Status**

1. Type of Emissions Unit Addressed in this Section: (Check one)

This Emissions Unit Information Section addresses, as a single emissions unit, a single process or production unit, or activity, which produces one or more air pollutants and which has at least one definable emission point (stack or vent).

This Emissions Unit Information Section addresses, as a single emissions unit, a group of process or production units and activities which has at least one definable emission point (stack or vent) but may also produce fugitive emissions.

This Emissions Unit Information Section addresses, as a single emissions unit, one or more process or production units and activities which produce fugitive emissions only.

2. Description of Emissions Unit Addressed in this Section:  
**Emergency firewater pump diesel engine fired with ultra low sulfur diesel (ULSD) fuel oil.**

3. Emissions Unit Identification Number: **019 (Unit 6 Emergency Firewater Pump Diesel Engine No. 1)**

4. Emissions Unit Status Code: <b>C</b>	5. Commence Construction Date: <b>N/A</b>	6. Initial Startup Date: <b>N/A</b>	7. Emissions Unit Major Group SIC Code: <b>49</b>	8. Acid Rain Unit? <input type="checkbox"/> Yes <input checked="" type="checkbox"/> No
--	--	--	--	--

9. Package Unit:  
 Manufacturer: \_\_\_\_\_ Model Number: \_\_\_\_\_

10. Generator Nameplate Rating: **MW**

11. Emissions Unit Comment:

**EMISSIONS UNIT INFORMATION**  
Section [ 9 ] of [ 10 ]

**Emissions Unit Control Equipment**

1. Control Equipment/Method(s) Description:

**NO<sub>x</sub> and CO**

**Diesel engine design**

**PM, PM<sub>10</sub>, SO<sub>2</sub>, and H<sub>2</sub>SO<sub>4</sub> Mist**

**Ultra Low Sulfur Diesel (ULSD) Fuel Oil**

2. Control Device or Method Code(s):

**EMISSIONS UNIT INFORMATION**

Section [ 9 ] of [ 10 ]

**B. EMISSIONS UNIT CAPACITY INFORMATION**

(Optional for unregulated emissions units.)

**Emissions Unit Operating Capacity and Schedule**

1. Maximum Process or Throughput Rate: N/A
2. Maximum Production Rate: N/A
3. Maximum Heat Input Rate: 2.9 million Btu/hr
4. Maximum Incineration Rate: N/A pounds/hr tons/day
5. Requested Maximum Operating Schedule: hours/day weeks/year days/week <b>100</b> hours/year
6. Operating Capacity/Schedule Comment:  <b>Excluding operations during emergency conditions, the emergency firewater pump diesel engine will operate up to 100 hours per year for routine testing and maintenance.</b>

**EMISSIONS UNIT INFORMATION**  
**Section [ 9 ] of [ 10 ]**

**C. EMISSION POINT (STACK/VENT) INFORMATION**  
**(Optional for unregulated emissions units.)**

**Emission Point Description and Type**

1. Identification of Point on Plot Plan or Flow Diagram: <b>Unit 6 Emergency Firewater Pump Engine No. 1</b>		2. Emission Point Type Code: <b>1</b>	
3. Descriptions of Emission Points Comprising this Emissions Unit for VE Tracking:  <b>N/A</b>			
4. ID Numbers or Descriptions of Emission Units with this Emission Point in Common:  <b>N/A</b>			
5. Discharge Type Code: <b>V</b>	6. Stack Height: <b>12 feet</b>	7. Exit Diameter: <b>0.7 feet</b>	
8. Exit Temperature: <b>790 °F</b>	9. Actual Volumetric Flow Rate: <b>2,080 acfm</b>	10. Water Vapor: <b>N/A %</b>	
11. Maximum Dry Standard Flow Rate: <b>N/A dscfm</b>		12. Nonstack Emission Point Height: <b>N/A feet</b>	
13. Emission Point UTM Coordinates Zone: East (km): <b>N/A</b> North (km): <b>N/A</b>		14. Emission Point Latitude/Longitude <b>N/A</b> Latitude (DD/MM/SS) <b>N/A</b> Longitude (DD/MM/SS)	
15. Emission Point Comment:			

**EMISSIONS UNIT INFORMATION**

Section [ 9 ] of [ 10 ]

**D. SEGMENT (PROCESS/FUEL) INFORMATION**

**Segment Description and Rate:** Segment  1  of  1

1. Segment Description (Process/Fuel Type):  <b>Emergency firewater pump diesel engine fired with distillate fuel oil</b>		
2. Source Classification Code (SCC): <b>2-01-001-02</b>		3. SCC Units: <b>Thousand Gallons Burned</b>
4. Maximum Hourly Rate: <b>0.022</b>	5. Maximum Annual Rate: <b>2.19</b>	6. Estimated Annual Activity Factor:
7. Maximum % Sulfur: <b>0.0015</b>	8. Maximum % Ash: <b>0.01</b>	9. Million Btu per SCC Unit: <b>134</b>
10. Segment Comment:  <b>Fuel flow estimated based on engine rating of 420 hp and assumed heat rate of 7,000 Btu/hp-hr.</b>		

**Segment Description and Rate:** Segment of

1. Segment Description (Process/Fuel Type):		
2. Source Classification Code (SCC):		3. SCC Units:
4. Maximum Hourly Rate:	5. Maximum Annual Rate:	6. Estimated Annual Activity Factor:
7. Maximum % Sulfur:	8. Maximum % Ash:	9. Million Btu per SCC Unit:
10. Segment Comment:		

**EMISSIONS UNIT INFORMATION**

Section [ 9 ] of [ 10 ]

**E. EMISSIONS UNIT POLLUTANTS**

**List of Pollutants Emitted by Emissions Unit**

1. Pollutant Emitted	2. Primary Control Device Code	3. Secondary Control Device Code	4. Pollutant Regulatory Code
1 – NOX			EL
2 – SO2			EL
3 – PM			EL
4 – PM10			EL
5 – CO			EL
6 – VOC			NS
7 – SAM			WP

**F1. EMISSIONS UNIT POLLUTANT DETAIL INFORMATION –  
POTENTIAL, FUGITIVE, AND ACTUAL EMISSIONS**

(Optional for unregulated emissions units.)

**Potential, Estimated Fugitive, and Baseline & Projected Actual Emissions**

Complete for each pollutant identified in Subsection E if applying for an air construction permit or concurrent processing of an air construction permit and a revised or renewal Title V permit. Complete for each emissions-limited pollutant identified in Subsection E if applying for an air operation permit.

1. Pollutant Emitted: <b>NOX</b>		2. Total Percent Efficiency of Control:	
3. Potential Emissions: <b>7.2 lb/hour</b> <b>0.4 tons/year</b>		4. Synthetically Limited? <input checked="" type="checkbox"/> Yes <input type="checkbox"/> No	
5. Range of Estimated Fugitive Emissions (as applicable): <b>N/A</b> to tons/year			
6. Emission Factor: <b>10.5 grams per kilowatt-hour (g/kWh)</b> Reference: <b>NSPS Subpart III.</b>		7. Emissions Method Code: <b>0</b>	
8.a. Baseline Actual Emissions (if required): <b>N/A tons/year</b>		8.b. Baseline 24-month Period: <b>N/A</b> From:                      To:	
9.a. Projected Actual Emissions (if required): <b>N/A tons/year</b>		9.b. Projected Monitoring Period: <b>N/A</b> <input type="checkbox"/> 5 years <input type="checkbox"/> 10 years	
10. Calculation of Emissions:  <b>Detailed emission calculations are provided in Appendix A.</b>			
11. Potential, Fugitive, and Actual Emissions Comment:  <b>Excluding operations during emergency conditions, the emergency firewater pump diesel engine will operate up to 100 hours per year for routine testing and maintenance.</b>			



**F2. EMISSIONS UNIT POLLUTANT DETAIL INFORMATION -  
ALLOWABLE EMISSIONS**

Complete if the pollutant identified in Subsection F1 is or would be subject to a numerical emissions limitation.

**Allowable Emissions** Allowable Emissions  1  of  1

1. Basis for Allowable Emissions Code: <b>RULE (BACT)</b>	2. Future Effective Date of Allowable Emissions: N/A
3. Allowable Emissions and Units: <b>10.5 g/kWh</b>	4. Equivalent Allowable Emissions: <b>7.2 lb/hour      0.4 tons/year</b>
5. Method of Compliance: <b>Engine manufacturer certification per NSPS Subpart III.</b>	
6. Allowable Emissions Comment (Description of Operating Method): <b>Limit in Field 3 is for NO<sub>x</sub> + NMHC per NSPS Subpart III. Rule 62-212.400(4)(c), F.A.C.</b>	

**Allowable Emissions** Allowable Emissions    of

1. Basis for Allowable Emissions Code:	2. Future Effective Date of Allowable Emissions:
3. Allowable Emissions and Units:	4. Equivalent Allowable Emissions: lb/hour      tons/year
5. Method of Compliance:	
6. Allowable Emissions Comment (Description of Operating Method):	
6. Allowable Emissions Comment (Description of Operating Method):	

**F1. EMISSIONS UNIT POLLUTANT DETAIL INFORMATION –  
POTENTIAL, FUGITIVE, AND ACTUAL EMISSIONS**

(Optional for unregulated emissions units.)

**Potential, Estimated Fugitive, and Baseline & Projected Actual Emissions**

Complete for each pollutant identified in Subsection E if applying for an air construction permit or concurrent processing of an air construction permit and a revised or renewal Title V permit. Complete for each emissions-limited pollutant identified in Subsection E if applying for an air operation permit.

1. Pollutant Emitted: <b>SO2</b>		2. Total Percent Efficiency of Control:	
3. Potential Emissions: <b>0.005 lb/hour      0.0003 tons/year</b>		4. Synthetically Limited? <input checked="" type="checkbox"/> Yes <input type="checkbox"/> No	
5. Range of Estimated Fugitive Emissions (as applicable): <b>N/A</b> to tons/year			
6. Emission Factor: <b>0.0074 g/kWh</b>  Reference: <b>AP-42.</b>		7. Emissions Method Code: <b>3</b>	
8.a. Baseline Actual Emissions (if required): <b>N/A tons/year</b>	8.b. Baseline 24-month Period: <b>N/A</b> From:                          To:		
9.a. Projected Actual Emissions (if required): <b>N/A tons/year</b>	9.b. Projected Monitoring Period: <b>N/A</b> <input type="checkbox"/> 5 years <input type="checkbox"/> 10 years		
10. Calculation of Emissions:  <b>Detailed emission calculations are provided in Appendix A.</b>			
11. Potential, Fugitive, and Actual Emissions Comment:  <b>Excluding operations during emergency conditions, the emergency firewater pump diesel engine will operate up to 100 hours per year for routine testing and maintenance.</b>			

**F2. EMISSIONS UNIT POLLUTANT DETAIL INFORMATION -  
ALLOWABLE EMISSIONS**

Complete if the pollutant identified in Subsection F1 is or would be subject to a numerical emissions limitation.

**Allowable Emissions** Allowable Emissions 1 of 1

1. Basis for Allowable Emissions Code: <b>RULE (BACT)</b>	2. Future Effective Date of Allowable Emissions: N/A
3. Allowable Emissions and Units: <b>0.0015 % S fuel oil</b>	4. Equivalent Allowable Emissions: <b>0.005 lb/hour 0.0003 tons/year</b>
5. Method of Compliance: <b>Fuel oil analysis for sulfur content.</b>	
6. Allowable Emissions Comment (Description of Operating Method):  <b>Rule 62-212.400(4)(c), F.A.C.</b>	

**Allowable Emissions** Allowable Emissions of

1. Basis for Allowable Emissions Code:	2. Future Effective Date of Allowable Emissions:
3. Allowable Emissions and Units:	4. Equivalent Allowable Emissions: lb/hour tons/year
5. Method of Compliance:	
6. Allowable Emissions Comment (Description of Operating Method):	

**Allowable Emissions** Allowable Emissions of

1. Basis for Allowable Emissions Code:	2. Future Effective Date of Allowable Emissions:
3. Allowable Emissions and Units:	4. Equivalent Allowable Emissions: lb/hour tons/year
5. Method of Compliance:	
6. Allowable Emissions Comment (Description of Operating Method):	

**F1. EMISSIONS UNIT POLLUTANT DETAIL INFORMATION –  
POTENTIAL, FUGITIVE, AND ACTUAL EMISSIONS**

(Optional for unregulated emissions units.)

**Potential, Estimated Fugitive, and Baseline & Projected Actual Emissions**

Complete for each pollutant identified in Subsection E if applying for an air construction permit or concurrent processing of an air construction permit and a revised or renewal Title V permit. Complete for each emissions-limited pollutant identified in Subsection E if applying for an air operation permit.

1. Pollutant Emitted: <b>PM/PM10</b>		2. Total Percent Efficiency of Control:	
3. Potential Emissions: <b>0.4 lb/hour</b> <b>0.02 tons/year</b>		4. Synthetically Limited? <input checked="" type="checkbox"/> Yes <input type="checkbox"/> No	
5. Range of Estimated Fugitive Emissions (as applicable): <b>N/A</b> to tons/year			
6. Emission Factor: <b>0.54 g/kWh</b> Reference: <b>NSPS Subpart III.</b>		7. Emissions Method Code: <b>0</b>	
8.a. Baseline Actual Emissions (if required): <b>N/A tons/year</b>		8.b. Baseline 24-month Period: <b>N/A</b> From:                      To:	
9.a. Projected Actual Emissions (if required): <b>N/A tons/year</b>		9.b. Projected Monitoring Period: <b>N/A</b> <input type="checkbox"/> 5 years <input type="checkbox"/> 10 years	
10. Calculation of Emissions:  <b>Detailed emission calculations are provided in Appendix A.</b>			
11. Potential, Fugitive, and Actual Emissions Comment:  <b>Excluding operations during emergency conditions, the emergency firewater pump diesel engine will operate up to 100 hours per year for routine testing and maintenance.</b>			

**F2. EMISSIONS UNIT POLLUTANT DETAIL INFORMATION -  
ALLOWABLE EMISSIONS**

Complete if the pollutant identified in Subsection F1 is or would be subject to a numerical emissions limitation.

**Allowable Emissions** Allowable Emissions 1 of 1

1. Basis for Allowable Emissions Code: <b>RULE (BACT)</b>	2. Future Effective Date of Allowable Emissions: N/A
3. Allowable Emissions and Units: <b>0.54 g/kWh</b>	4. Equivalent Allowable Emissions: <b>0.4 lb/hour      0.02 tons/year</b>
5. Method of Compliance: <b>Engine manufacturer certification per NSPS Subpart III.</b>	
6. Allowable Emissions Comment (Description of Operating Method):  <b>Rule 62-212.400(4)(c), F.A.C.</b>	

**Allowable Emissions** Allowable Emissions    of

1. Basis for Allowable Emissions Code:	2. Future Effective Date of Allowable Emissions:
3. Allowable Emissions and Units:	4. Equivalent Allowable Emissions: lb/hour      tons/year
5. Method of Compliance:	
6. Allowable Emissions Comment (Description of Operating Method):	

**Allowable Emissions** Allowable Emissions    of

1. Basis for Allowable Emissions Code:	2. Future Effective Date of Allowable Emissions:
3. Allowable Emissions and Units:	4. Equivalent Allowable Emissions: lb/hour      tons/year
5. Method of Compliance:	
6. Allowable Emissions Comment (Description of Operating Method):	

**F1. EMISSIONS UNIT POLLUTANT DETAIL INFORMATION –  
POTENTIAL, FUGITIVE, AND ACTUAL EMISSIONS**

(Optional for unregulated emissions units.)

**Potential, Estimated Fugitive, and Baseline & Projected Actual Emissions**

**Complete for each pollutant identified in Subsection E if applying for an air construction permit or concurrent processing of an air construction permit and a revised or renewal Title V permit. Complete for each emissions-limited pollutant identified in Subsection E if applying for an air operation permit.**

1. Pollutant Emitted: <b>CO</b>		2. Total Percent Efficiency of Control:	
3. Potential Emissions: <b>2.4 lb/hour</b> <b>0.1 tons/year</b>		4. Synthetically Limited? <input checked="" type="checkbox"/> Yes <input type="checkbox"/> No	
5. Range of Estimated Fugitive Emissions (as applicable): <b>N/A</b> to tons/year			
6. Emission Factor: <b>3.5 g/kWh</b>  Reference: <b>NSPS Subpart III.</b>		7. Emissions Method Code: <b>0</b>	
8.a. Baseline Actual Emissions (if required): <b>N/A tons/year</b>		8.b. Baseline 24-month Period: <b>N/A</b> From:                      To:	
9.a. Projected Actual Emissions (if required): <b>N/A tons/year</b>		9.b. Projected Monitoring Period: <b>N/A</b> <input type="checkbox"/> 5 years <input type="checkbox"/> 10 years	
10. Calculation of Emissions:  <b>Detailed emission calculations are provided in Appendix A.</b>			
11. Potential, Fugitive, and Actual Emissions Comment:  <b>Excluding operations during emergency conditions, the emergency firewater pump diesel engine will operate up to 100 hours per year for routine testing and maintenance.</b>			

**F2. EMISSIONS UNIT POLLUTANT DETAIL INFORMATION -  
 ALLOWABLE EMISSIONS**

**Complete if the pollutant identified in Subsection F1 is or would be subject to a numerical emissions limitation.**

**Allowable Emissions** Allowable Emissions  1  of  1

1. Basis for Allowable Emissions Code: <b>RULE (BACT)</b>	2. Future Effective Date of Allowable Emissions: <b>N/A</b>
3. Allowable Emissions and Units: <b>3.5 g/kWh</b>	4. Equivalent Allowable Emissions: <b>2.4 lb/hour      0.1 tons/year</b>
5. Method of Compliance: <b>Engine manufacturer certification per NSPS Subpart III.</b>	
6. Allowable Emissions Comment (Description of Operating Method):  <b>Rule 62-212.400(4)(c), F.A.C.</b>	

**Allowable Emissions** Allowable Emissions    of

1. Basis for Allowable Emissions Code:	2. Future Effective Date of Allowable Emissions:
3. Allowable Emissions and Units:	4. Equivalent Allowable Emissions: <b>lb/hour      tons/year</b>
5. Method of Compliance:	
6. Allowable Emissions Comment (Description of Operating Method):	

**Allowable Emissions** Allowable Emissions    of

1. Basis for Allowable Emissions Code:	2. Future Effective Date of Allowable Emissions:
3. Allowable Emissions and Units:	4. Equivalent Allowable Emissions: <b>lb/hour      tons/year</b>
5. Method of Compliance:	
6. Allowable Emissions Comment (Description of Operating Method):	

**F1. EMISSIONS UNIT POLLUTANT DETAIL INFORMATION –  
POTENTIAL, FUGITIVE, AND ACTUAL EMISSIONS**

(Optional for unregulated emissions units.)

**Potential, Estimated Fugitive, and Baseline & Projected Actual Emissions**

Complete for each pollutant identified in Subsection E if applying for an air construction permit or concurrent processing of an air construction permit and a revised or renewal Title V permit. Complete for each emissions-limited pollutant identified in Subsection E if applying for an air operation permit.

1. Pollutant Emitted: <b>VOC</b>		2. Total Percent Efficiency of Control:	
3. Potential Emissions: <b>1.1 lb/hour</b> <b>0.05 tons/year</b>		4. Synthetically Limited? <input checked="" type="checkbox"/> Yes <input type="checkbox"/> No	
5. Range of Estimated Fugitive Emissions (as applicable): <b>N/A</b> to tons/year			
6. Emission Factor: <b>1.5 g/kWh</b>  Reference: <b>AP-42.</b>		7. Emissions Method Code: <b>3</b>	
8.a. Baseline Actual Emissions (if required): <b>N/A tons/year</b>		8.b. Baseline 24-month Period: <b>N/A</b> From:                      To:	
9.a. Projected Actual Emissions (if required): <b>N/A tons/year</b>		9.b. Projected Monitoring Period: <b>N/A</b> <input type="checkbox"/> 5 years <input type="checkbox"/> 10 years	
10. Calculation of Emissions:  <b>Detailed emission calculations are provided in Appendix A.</b>			
11. Potential, Fugitive, and Actual Emissions Comment:  <b>Excluding operations during emergency conditions, the emergency firewater pump diesel engine will operate up to 100 hours per year for routine testing and maintenance.</b>			



**F2. EMISSIONS UNIT POLLUTANT DETAIL INFORMATION -  
ALLOWABLE EMISSIONS N/A**

**Complete if the pollutant identified in Subsection F1 is or would be subject to a numerical emissions limitation.**

**Allowable Emissions** Allowable Emissions of

1. Basis for Allowable Emissions Code:	2. Future Effective Date of Allowable Emissions:
3. Allowable Emissions and Units:	4. Equivalent Allowable Emissions: lb/hour                      tons/year
5. Method of Compliance:	
6. Allowable Emissions Comment (Description of Operating Method):	

**Allowable Emissions** Allowable Emissions of

1. Basis for Allowable Emissions Code:	2. Future Effective Date of Allowable Emissions:
3. Allowable Emissions and Units:	4. Equivalent Allowable Emissions: lb/hour                      tons/year
5. Method of Compliance:	
6. Allowable Emissions Comment (Description of Operating Method):	

**Allowable Emissions** Allowable Emissions of

1. Basis for Allowable Emissions Code:	2. Future Effective Date of Allowable Emissions:
3. Allowable Emissions and Units:	4. Equivalent Allowable Emissions: lb/hour                      tons/year
5. Method of Compliance:	
6. Allowable Emissions Comment (Description of Operating Method):	

**F1. EMISSIONS UNIT POLLUTANT DETAIL INFORMATION –  
POTENTIAL, FUGITIVE, AND ACTUAL EMISSIONS**

(Optional for unregulated emissions units.)

**Potential, Estimated Fugitive, and Baseline & Projected Actual Emissions**

**Complete for each pollutant identified in Subsection E if applying for an air construction permit or concurrent processing of an air construction permit and a revised or renewal Title V permit. Complete for each emissions-limited pollutant identified in Subsection E if applying for an air operation permit.**

1. Pollutant Emitted: <b>SAM</b>		2. Total Percent Efficiency of Control:	
3. Potential Emissions: Neg. lb/hour                      Neg. tons/year		4. Synthetically Limited? <input checked="" type="checkbox"/> Yes <input type="checkbox"/> No	
5. Range of Estimated Fugitive Emissions (as applicable): <b>N/A</b> to tons/year			
6. Emission Factor: <b>N/A</b> Reference: <b>ECT, 2007.</b>		7. Emissions Method Code: <b>2</b>	
8.a. Baseline Actual Emissions (if required): <b>N/A tons/year</b>		8.b. Baseline 24-month Period: <b>N/A</b> From:                                      To:	
9.a. Projected Actual Emissions (if required): <b>N/A tons/year</b>		9.b. Projected Monitoring Period: <b>N/A</b> <input type="checkbox"/> 5 years <input type="checkbox"/> 10 years	
10. Calculation of Emissions:  <b>Emergency generator diesel engine sulfuric acid mist emissions resulting from the combustion of ULSD fuel oil will be negligible.</b>			
11. Potential, Fugitive, and Actual Emissions Comment:  <b>Excluding operations during emergency conditions, the emergency firewater pump diesel engine will operate up to 100 hours per year for routine testing and maintenance.</b>			

**F2. EMISSIONS UNIT POLLUTANT DETAIL INFORMATION -  
 ALLOWABLE EMISSIONS**

**Complete if the pollutant identified in Subsection F1 is or would be subject to a numerical emissions limitation.**

**Allowable Emissions** Allowable Emissions  1  of  1

1. Basis for Allowable Emissions Code: <b>RULE (BACT)</b>	2. Future Effective Date of Allowable Emissions: <b>N/A</b>
3. Allowable Emissions and Units: <b>0.0015 % S fuel oil</b>	4. Equivalent Allowable Emissions: <b>N/A lb/hour      N/A tons/year</b>
5. Method of Compliance: <b>Fuel oil analysis for sulfur content.</b>	
6. Allowable Emissions Comment (Description of Operating Method):  <b>Rule 62-212.400(4)(c), F.A.C.</b>	

**Allowable Emissions** Allowable Emissions    of

1. Basis for Allowable Emissions Code:	2. Future Effective Date of Allowable Emissions:
3. Allowable Emissions and Units:	4. Equivalent Allowable Emissions: <b>lb/hour      tons/year</b>
5. Method of Compliance:	
6. Allowable Emissions Comment (Description of Operating Method):	

**Allowable Emissions** Allowable Emissions    of

1. Basis for Allowable Emissions Code:	2. Future Effective Date of Allowable Emissions:
3. Allowable Emissions and Units:	4. Equivalent Allowable Emissions: <b>lb/hour      tons/year</b>
5. Method of Compliance:	
6. Allowable Emissions Comment (Description of Operating Method):	

**EMISSIONS UNIT INFORMATION**

Section [ 9 ] of [ 10 ]

**G. VISIBLE EMISSIONS INFORMATION****Complete if this emissions unit is or would be subject to a unit-specific visible emissions limitation.****Visible Emissions Limitation:** Visible Emissions Limitation 1 of 2

1. Visible Emissions Subtype: <b>VE20</b>	2. Basis for Allowable Opacity: <input checked="" type="checkbox"/> Rule <input type="checkbox"/> Other
3. Allowable Opacity: Normal Conditions: <b>20 %</b> Exceptional Conditions: % Maximum Period of Excess Opacity Allowed: min/hour	
4. Method of Compliance: <b>EPA Reference Method 9</b>	
5. Visible Emissions Comment:  <b>Rule 62-296.320(4)(b), F.A.C.</b>	

**Visible Emissions Limitation:** Visible Emissions Limitation 2 of 2

1. Visible Emissions Subtype: <b>VE99</b>	2. Basis for Allowable Opacity: <input checked="" type="checkbox"/> Rule <input type="checkbox"/> Other
3. Allowable Opacity: Normal Conditions: % Exceptional Conditions: % Maximum Period of Excess Opacity Allowed: <b>60</b> min/hour	
4. Method of Compliance: <b>EPA Reference Method 9</b>	
5. Visible Emissions Comment:  <b>Excess emissions resulting from startup, shutdown or malfunction of any emissions unit shall be permitted providing (1) best operational practices to minimize emissions are adhered to and (2) the duration of excess emissions shall be minimized but in no case exceed two hours in any 24 hour period unless specifically authorized by the Department for longer duration.</b>  <b>Rule 62-210.700(1), F.A.C.</b>	

**EMISSIONS UNIT INFORMATION**

Section [ 9 ] of [ 10 ]

**H. CONTINUOUS MONITOR INFORMATION – N/A**

**Complete if this emissions unit is or would be subject to continuous monitoring.**

**Continuous Monitoring System:** Continuous Monitor of

1. Parameter Code:	2. Pollutant(s):
3. CMS Requirement:	<input type="checkbox"/> Rule <input type="checkbox"/> Other
4. Monitor Information Manufacturer: Model Number:	Serial Number:
5. Installation Date:	6. Performance Specification Test Date:
7. Continuous Monitor Comment:	

**Continuous Monitoring System:** Continuous Monitor of

1. Parameter Code:	2. Pollutant(s):
3. CMS Requirement:	<input type="checkbox"/> Rule <input type="checkbox"/> Other
4. Monitor Information Manufacturer: Model Number:	Serial Number:
5. Installation Date:	6. Performance Specification Test Date:
7. Continuous Monitor Comment:	

**EMISSIONS UNIT INFORMATION**

Section [ 9 ] of [ 10 ]

**I. EMISSIONS UNIT ADDITIONAL INFORMATION**

**Additional Requirements for All Applications, Except as Otherwise Stated**

1. Process Flow Diagram (Required for all permit applications, except Title V air operation permit revision applications if this information was submitted to the department within the previous five years and would not be altered as a result of the revision being sought) <input checked="" type="checkbox"/> Attached, Document ID: <u>Fig. 2-4</u> <input type="checkbox"/> Previously Submitted, Date _____
2. Fuel Analysis or Specification (Required for all permit applications, except Title V air operation permit revision applications if this information was submitted to the department within the previous five years and would not be altered as a result of the revision being sought) <input checked="" type="checkbox"/> Attached, Document ID: <u>Section 2.2, Table 2-5</u>
3. Detailed Description of Control Equipment (Required for all permit applications, except Title V air operation permit revision applications if this information was submitted to the department within the previous five years and would not be altered as a result of the revision being sought) <input checked="" type="checkbox"/> Attached, Document ID: <u>Section 2.0</u> <input type="checkbox"/> Previously Submitted, Date _____
4. Procedures for Startup and Shutdown (Required for all operation permit applications, except Title V air operation permit revision applications if this information was submitted to the department within the previous five years and would not be altered as a result of the revision being sought) <input checked="" type="checkbox"/> Not Applicable (construction application)
5. Operation and Maintenance Plan (Required for all permit applications, except Title V air operation permit revision applications if this information was submitted to the department within the previous five years and would not be altered as a result of the revision being sought) <input type="checkbox"/> Attached, Document ID: _____ <input type="checkbox"/> Previously Submitted, Date _____ <input checked="" type="checkbox"/> Not Applicable
6. Compliance Demonstration Reports/Records <input type="checkbox"/> Attached, Document ID: _____ Test Date(s)/Pollutant(s) Tested: _____ _____ <input type="checkbox"/> Previously Submitted, Date: _____ Test Date(s)/Pollutant(s) Tested: _____ _____ <input type="checkbox"/> To be Submitted, Date (if known): _____ Test Date(s)/Pollutant(s) Tested: _____ _____ <input checked="" type="checkbox"/> Not Applicable  Note: For FESOP applications, all required compliance demonstration records/reports must be submitted at the time of application. For Title V air operation permit applications, all required compliance demonstration reports/records must be submitted at the time of application, or a compliance plan must be submitted at the time of application.
7. Other Information Required by Rule or Statute <input type="checkbox"/> Attached, Document ID: _____ <input checked="" type="checkbox"/> Not Applicable

**EMISSIONS UNIT INFORMATION**

Section | 9 | of | 10 |

**Additional Requirements for Air Construction Permit Applications**

1. Control Technology Review and Analysis (Rules 62-212.400(10) and 62-212.500(7), F.A.C.; 40 CFR 63.43(d) and (e)) <input checked="" type="checkbox"/> Attached, Document ID: <u>Section 5.0</u> <input type="checkbox"/> Not Applicable
2. Good Engineering Practice Stack Height Analysis (Rule 62-212.400(4)(d), F.A.C., and Rule 62-212.500(4)(f), F.A.C.) <input checked="" type="checkbox"/> Attached, Document ID: <u>Section 6.0</u> <input type="checkbox"/> Not Applicable
3. Description of Stack Sampling Facilities (Required for proposed new stack sampling facilities only) <input type="checkbox"/> Attached, Document ID: _____ <input checked="" type="checkbox"/> Not Applicable

**Additional Requirements for Title V Air Operation Permit Applications** **NOT APPLICABLE**

1. Identification of Applicable Requirements <input type="checkbox"/> Attached, Document ID: _____
2. Compliance Assurance Monitoring <input type="checkbox"/> Attached, Document ID: _____ <input type="checkbox"/> Not Applicable
3. Alternative Methods of Operation <input type="checkbox"/> Attached, Document ID: _____ <input type="checkbox"/> Not Applicable
4. Alternative Modes of Operation (Emissions Trading) <input type="checkbox"/> Attached, Document ID: _____ <input type="checkbox"/> Not Applicable
5. Acid Rain Part Application <input type="checkbox"/> Certificate of Representation (EPA Form No. 7610-1) <input type="checkbox"/> Copy Attached, Document ID: _____ <input type="checkbox"/> Acid Rain Part (Form No. 62-210.900(1)(a)) <input type="checkbox"/> Attached, Document ID: _____ <input type="checkbox"/> Previously Submitted, Date: _____ <input type="checkbox"/> Repowering Extension Plan (Form No. 62-210.900(1)(a)1.) <input type="checkbox"/> Attached, Document ID: _____ <input type="checkbox"/> Previously Submitted, Date: _____ <input type="checkbox"/> New Unit Exemption (Form No. 62-210.900(1)(a)2.) <input type="checkbox"/> Attached, Document ID: _____ <input type="checkbox"/> Previously Submitted, Date: _____ <input type="checkbox"/> Retired Unit Exemption (Form No. 62-210.900(1)(a)3.) <input type="checkbox"/> Attached, Document ID: _____ <input type="checkbox"/> Previously Submitted, Date: _____ <input type="checkbox"/> Phase II NOx Compliance Plan (Form No. 62-210.900(1)(a)4.) <input type="checkbox"/> Attached, Document ID: _____ <input type="checkbox"/> Previously Submitted, Date: _____ <input type="checkbox"/> Phase II NOx Averaging Plan (Form No. 62-210.900(1)(a)5.) <input type="checkbox"/> Attached, Document ID: _____ <input type="checkbox"/> Previously Submitted, Date: _____ <input type="checkbox"/> Not Applicable

**EMISSIONS UNIT INFORMATION**

Section [ 9 ] of [ 10 ]

**Additional Requirements Comment**

[Empty comment box]



**EMISSION EMISSIONS UNIT INFORMATION**

Section | 10 | of | 10 |

**A. GENERAL EMISSIONS UNIT INFORMATION**

**Title V Air Operation Permit Emissions Unit Classification**

1. Regulated or Unregulated Emissions Unit? (Check one, if applying for an initial, revised or renewal Title V air operation permit. Skip this item if applying for an air construction permit or FESOP only.)

The emissions unit addressed in this Emissions Unit Information Section is a regulated emissions unit.

The emissions unit addressed in this Emissions Unit Information Section is an unregulated emissions unit.

**Emissions Unit Description and Status**

1. Type of Emissions Unit Addressed in this Section: (Check one)

This Emissions Unit Information Section addresses, as a single emissions unit, a single process or production unit, or activity, which produces one or more air pollutants and which has at least one definable emission point (stack or vent).

This Emissions Unit Information Section addresses, as a single emissions unit, a group of process or production units and activities which has at least one definable emission point (stack or vent) but may also produce fugitive emissions.

This Emissions Unit Information Section addresses, as a single emissions unit, one or more process or production units and activities which produce fugitive emissions only.

2. Description of Emissions Unit Addressed in this Section:  
**Emergency firewater pump diesel engine fired with ultra low sulfur diesel (ULSD) fuel oil.**

3. Emissions Unit Identification Number: **020 (Unit 6 Emergency Firewater Pump Diesel Engine No. 2)**

4. Emissions Unit Status Code: <b>C</b>	5. Commence Construction Date: <b>N/A</b>	6. Initial Startup Date: <b>N/A</b>	7. Emissions Unit Major Group SIC Code: <b>49</b>	8. Acid Rain Unit? <input type="checkbox"/> Yes <input checked="" type="checkbox"/> No
--	--	--	--	--

9. Package Unit:  
 Manufacturer: \_\_\_\_\_ Model Number: \_\_\_\_\_

10. Generator Nameplate Rating: **MW**

11. Emissions Unit Comment:

**EMISSIONS UNIT INFORMATION**

**Section [ 10 ] of [ 10 ]**

**Emissions Unit Control Equipment**

1. Control Equipment/Method(s) Description:

**NO<sub>x</sub> and CO**

**Diesel engine design**

**PM, PM<sub>10</sub>, SO<sub>2</sub>, and H<sub>2</sub>SO<sub>4</sub> Mist**

**Ultra Low Sulfur Diesel (ULSD) Fuel Oil**

2. Control Device or Method Code(s):

**EMISSIONS UNIT INFORMATION**

Section [ 10 ] of [ 10 ]

**B. EMISSIONS UNIT CAPACITY INFORMATION**

(Optional for unregulated emissions units.)

**Emissions Unit Operating Capacity and Schedule**

1. Maximum Process or Throughput Rate: N/A
2. Maximum Production Rate: N/A
3. Maximum Heat Input Rate: 2.9 million Btu/hr
4. Maximum Incineration Rate: N/A pounds/hr tons/day
5. Requested Maximum Operating Schedule: hours/day days/week weeks/year 100 hours/year
6. Operating Capacity/Schedule Comment:  <b>Excluding operations during emergency conditions, the emergency firewater pump diesel engine will operate up to 100 hours per year for routine testing and maintenance.</b>

**EMISSIONS UNIT INFORMATION**

Section [ 10 ] of [ 10 ]

**C. EMISSION POINT (STACK/VENT) INFORMATION**  
**(Optional for unregulated emissions units.)**

**Emission Point Description and Type**

1. Identification of Point on Plot Plan or Flow Diagram: <b>Unit 6 Emergency Firewater Pump Engine No. 2</b>		2. Emission Point Type Code: <b>1</b>	
3. Descriptions of Emission Points Comprising this Emissions Unit for VE Tracking:  <b>N/A</b>			
4. ID Numbers or Descriptions of Emission Units with this Emission Point in Common:  <b>N/A</b>			
5. Discharge Type Code: <b>V</b>	6. Stack Height: <b>12 feet</b>	7. Exit Diameter: <b>0.7 feet</b>	
8. Exit Temperature: <b>790 °F</b>	9. Actual Volumetric Flow Rate: <b>2,080 acfm</b>	10. Water Vapor: <b>N/A %</b>	
11. Maximum Dry Standard Flow Rate: <b>N/A dscfm</b>		12. Nonstack Emission Point Height: <b>N/A feet</b>	
13. Emission Point UTM Coordinates Zone: East (km): <b>N/A</b> North (km): <b>N/A</b>		14. Emission Point Latitude/Longitude <b>N/A</b> Latitude (DD/MM/SS) <b>N/A</b> Longitude (DD/MM/SS)	
15. Emission Point Comment:			

**EMISSIONS UNIT INFORMATION**

Section [ 10 ] of [ 10 ]

**D. SEGMENT (PROCESS/FUEL) INFORMATION**

**Segment Description and Rate:** Segment 1 of 1

1. Segment Description (Process/Fuel Type):  <b>Emergency firewater pump diesel engine fired with distillate fuel oil</b>		
2. Source Classification Code (SCC): <b>2-01-001-02</b>		3. SCC Units: <b>Thousand Gallons Burned</b>
4. Maximum Hourly Rate: <b>0.022</b>	5. Maximum Annual Rate: <b>2.19</b>	6. Estimated Annual Activity Factor:
7. Maximum % Sulfur: <b>0.0015</b>	8. Maximum % Ash: <b>0.01</b>	9. Million Btu per SCC Unit: <b>134</b>
10. Segment Comment:  <b>Fuel flow estimated based on engine rating of 420 hp and assumed heat rate of 7,000 Btu/hp-hr.</b>		

**Segment Description and Rate:** Segment of

1. Segment Description (Process/Fuel Type):		
2. Source Classification Code (SCC):		3. SCC Units:
4. Maximum Hourly Rate:	5. Maximum Annual Rate:	6. Estimated Annual Activity Factor:
7. Maximum % Sulfur:	8. Maximum % Ash:	9. Million Btu per SCC Unit:
10. Segment Comment:		

**EMISSIONS UNIT INFORMATION**

Section [ 10 ] of [ 10 ]

**E. EMISSIONS UNIT POLLUTANTS**

**List of Pollutants Emitted by Emissions Unit**

1. Pollutant Emitted	2. Primary Control Device Code	3. Secondary Control Device Code	4. Pollutant Regulatory Code
1 – NOX			EL
2 – SO2			EL
3 – PM			EL
4 – PM10			EL
5 – CO			EL
6 – VOC			NS
7 – SAM			WP

**F1. EMISSIONS UNIT POLLUTANT DETAIL INFORMATION –  
POTENTIAL, FUGITIVE, AND ACTUAL EMISSIONS**

**(Optional for unregulated emissions units.)**

**Potential, Estimated Fugitive, and Baseline & Projected Actual Emissions**

**Complete for each pollutant identified in Subsection E if applying for an air construction permit or concurrent processing of an air construction permit and a revised or renewal Title V permit. Complete for each emissions-limited pollutant identified in Subsection E if applying for an air operation permit.**

1. Pollutant Emitted: <b>NOX</b>		2. Total Percent Efficiency of Control:	
3. Potential Emissions: <b>7.2 lb/hour</b> <b>0.4 tons/year</b>		4. Synthetically Limited? <input checked="" type="checkbox"/> Yes <input type="checkbox"/> No	
5. Range of Estimated Fugitive Emissions (as applicable): <b>N/A</b> to tons/year			
6. Emission Factor: <b>10.5 grams per kilowatt-hour (g/kWh)</b> Reference: <b>NSPS Subpart III.</b>		7. Emissions Method Code: <b>0</b>	
8.a. Baseline Actual Emissions (if required): <b>N/A tons/year</b>		8.b. Baseline 24-month Period: <b>N/A</b> From:                                      To:	
9.a. Projected Actual Emissions (if required): <b>N/A tons/year</b>		9.b. Projected Monitoring Period: <b>N/A</b> <input type="checkbox"/> 5 years <input type="checkbox"/> 10 years	
10. Calculation of Emissions:  <b>Detailed emission calculations are provided in Appendix A.</b>			
11. Potential, Fugitive, and Actual Emissions Comment:  <b>Excluding operations during emergency conditions, the emergency firewater pump diesel engine will operate up to 100 hours per year for routine testing and maintenance.</b>			

F2. EMISSIONS UNIT POLLUTANT DETAIL INFORMATION -  
ALLOWABLE EMISSIONS

Complete if the pollutant identified in Subsection F1 is or would be subject to a numerical emissions limitation.

Allowable Emissions Allowable Emissions 1 of 1

1. Basis for Allowable Emissions Code: <b>RULE (BACT)</b>	2. Future Effective Date of Allowable Emissions: <b>N/A</b>
3. Allowable Emissions and Units: <b>10.5 g/kWh</b>	4. Equivalent Allowable Emissions: <b>7.2 lb/hour      0.4 tons/year</b>
5. Method of Compliance: <b>Engine manufacturer certification per NSPS Subpart III.</b>	
6. Allowable Emissions Comment (Description of Operating Method): <b>Limit in Field 3 is for NO<sub>x</sub> + NMHC per NSPS Subpart III. Rule 62-212.400(4)(c), F.A.C.</b>	

Allowable Emissions Allowable Emissions    of

1. Basis for Allowable Emissions Code:	2. Future Effective Date of Allowable Emissions:
3. Allowable Emissions and Units:	4. Equivalent Allowable Emissions: lb/hour      tons/year
5. Method of Compliance:	
6. Allowable Emissions Comment (Description of Operating Method):	
6. Allowable Emissions Comment (Description of Operating Method):	



**F1. EMISSIONS UNIT POLLUTANT DETAIL INFORMATION –  
 POTENTIAL, FUGITIVE, AND ACTUAL EMISSIONS**

**(Optional for unregulated emissions units.)**

**Potential, Estimated Fugitive, and Baseline & Projected Actual Emissions**

**Complete for each pollutant identified in Subsection E if applying for an air construction permit or concurrent processing of an air construction permit and a revised or renewal Title V permit. Complete for each emissions-limited pollutant identified in Subsection E if applying for an air operation permit.**

1. Pollutant Emitted: <b>SO2</b>		2. Total Percent Efficiency of Control:	
3. Potential Emissions: <b>0.005 lb/hour      0.0003 tons/year</b>		4. Synthetically Limited? <input checked="" type="checkbox"/> Yes <input type="checkbox"/> No	
5. Range of Estimated Fugitive Emissions (as applicable): <b>N/A</b> to tons/year			
6. Emission Factor: <b>0.0074 g/kWh</b>  Reference: <b>AP-42.</b>		7. Emissions Method Code: <b>3</b>	
8.a. Baseline Actual Emissions (if required): <b>N/A tons/year</b>		8.b. Baseline 24-month Period: <b>N/A</b> From:      To:	
9.a. Projected Actual Emissions (if required): <b>N/A tons/year</b>		9.b. Projected Monitoring Period: <b>N/A</b> <input type="checkbox"/> 5 years <input type="checkbox"/> 10 years	
10. Calculation of Emissions:  <b>Detailed emission calculations are provided in Appendix A.</b>			
11. Potential, Fugitive, and Actual Emissions Comment:  <b>Excluding operations during emergency conditions, the emergency firewater pump diesel engine will operate up to 100 hours per year for routine testing and maintenance.</b>			

F2. EMISSIONS UNIT POLLUTANT DETAIL INFORMATION -  
ALLOWABLE EMISSIONS

Complete if the pollutant identified in Subsection F1 is or would be subject to a numerical emissions limitation.

Allowable Emissions Allowable Emissions 1 of 1

1. Basis for Allowable Emissions Code: <b>RULE (BACT)</b>	2. Future Effective Date of Allowable Emissions: <b>N/A</b>
3. Allowable Emissions and Units: <b>0.0015 % S fuel oil</b>	4. Equivalent Allowable Emissions: <b>0.005 lb/hour      0.0003 tons/year</b>
5. Method of Compliance: <b>Fuel oil analysis for sulfur content.</b>	
6. Allowable Emissions Comment (Description of Operating Method):  <b>Rule 62-212.400(4)(c), F.A.C.</b>	

Allowable Emissions Allowable Emissions of

1. Basis for Allowable Emissions Code:	2. Future Effective Date of Allowable Emissions:
3. Allowable Emissions and Units:	4. Equivalent Allowable Emissions: lb/hour      tons/year
5. Method of Compliance:	
6. Allowable Emissions Comment (Description of Operating Method):	

Allowable Emissions Allowable Emissions of

1. Basis for Allowable Emissions Code:	2. Future Effective Date of Allowable Emissions:
3. Allowable Emissions and Units:	4. Equivalent Allowable Emissions: lb/hour      tons/year
5. Method of Compliance:	
6. Allowable Emissions Comment (Description of Operating Method):	

**F1. EMISSIONS UNIT POLLUTANT DETAIL INFORMATION –  
POTENTIAL, FUGITIVE, AND ACTUAL EMISSIONS**

(Optional for unregulated emissions units.)

**Potential, Estimated Fugitive, and Baseline & Projected Actual Emissions**

Complete for each pollutant identified in Subsection E if applying for an air construction permit or concurrent processing of an air construction permit and a revised or renewal Title V permit. Complete for each emissions-limited pollutant identified in Subsection E if applying for an air operation permit.

1. Pollutant Emitted: <b>PM/PM10</b>		2. Total Percent Efficiency of Control:	
3. Potential Emissions: <b>0.4 lb/hour</b> <b>0.02 tons/year</b>		4. Synthetically Limited? <input checked="" type="checkbox"/> Yes <input type="checkbox"/> No	
5. Range of Estimated Fugitive Emissions (as applicable): <b>N/A</b> to tons/year			
6. Emission Factor: <b>0.54 g/kWh</b>  Reference: <b>NSPS Subpart IIII.</b>		7. Emissions Method Code: <b>0</b>	
8.a. Baseline Actual Emissions (if required): <b>N/A tons/year</b>		8.b. Baseline 24-month Period: <b>N/A</b> From:                                      To:	
9.a. Projected Actual Emissions (if required): <b>N/A tons/year</b>		9.b. Projected Monitoring Period: <b>N/A</b> <input type="checkbox"/> 5 years <input type="checkbox"/> 10 years	
10. Calculation of Emissions:  <b>Detailed emission calculations are provided in Appendix A.</b>			
11. Potential, Fugitive, and Actual Emissions Comment:  <b>Excluding operations during emergency conditions, the emergency firewater pump diesel engine will operate up to 100 hours per year for routine testing and maintenance.</b>			

**F2. EMISSIONS UNIT POLLUTANT DETAIL INFORMATION -  
ALLOWABLE EMISSIONS**

Complete if the pollutant identified in Subsection F1 is or would be subject to a numerical emissions limitation.

**Allowable Emissions** Allowable Emissions  1  of  1

1. Basis for Allowable Emissions Code: <b>RULE (BACT)</b>	2. Future Effective Date of Allowable Emissions: <b>N/A</b>
3. Allowable Emissions and Units: <b>0.54 g/kWh</b>	4. Equivalent Allowable Emissions: <b>0.4 lb/hour      0.02 tons/year</b>
5. Method of Compliance: <b>Engine manufacturer certification per NSPS Subpart III.</b>	
6. Allowable Emissions Comment (Description of Operating Method):  <b>Rule 62-212.400(4)(c), F.A.C.</b>	

**Allowable Emissions** Allowable Emissions      of

1. Basis for Allowable Emissions Code:	2. Future Effective Date of Allowable Emissions:
3. Allowable Emissions and Units:	4. Equivalent Allowable Emissions: <b>lb/hour      tons/year</b>
5. Method of Compliance:	
6. Allowable Emissions Comment (Description of Operating Method):	

**Allowable Emissions** Allowable Emissions      of

1. Basis for Allowable Emissions Code:	2. Future Effective Date of Allowable Emissions:
3. Allowable Emissions and Units:	4. Equivalent Allowable Emissions: <b>lb/hour      tons/year</b>
5. Method of Compliance:	
6. Allowable Emissions Comment (Description of Operating Method):	

**F1. EMISSIONS UNIT POLLUTANT DETAIL INFORMATION –  
POTENTIAL, FUGITIVE, AND ACTUAL EMISSIONS**

**(Optional for unregulated emissions units.)**

**Potential, Estimated Fugitive, and Baseline & Projected Actual Emissions**

**Complete for each pollutant identified in Subsection E if applying for an air construction permit or concurrent processing of an air construction permit and a revised or renewal Title V permit. Complete for each emissions-limited pollutant identified in Subsection E if applying for an air operation permit.**

1. Pollutant Emitted: <b>CO</b>		2. Total Percent Efficiency of Control:	
3. Potential Emissions: <b>2.4 lb/hour</b> <b>0.1 tons/year</b>		4. Synthetically Limited? <input checked="" type="checkbox"/> Yes <input type="checkbox"/> No	
5. Range of Estimated Fugitive Emissions (as applicable): <b>N/A</b> to tons/year			
6. Emission Factor: <b>3.5 g/kWh</b>  Reference: <b>NSPS Subpart IIII.</b>		7. Emissions Method Code: <b>0</b>	
8.a. Baseline Actual Emissions (if required): <b>N/A tons/year</b>		8.b. Baseline 24-month Period: <b>N/A</b> From:                      To:	
9.a. Projected Actual Emissions (if required): <b>N/A tons/year</b>		9.b. Projected Monitoring Period: <b>N/A</b> <input type="checkbox"/> 5 years <input type="checkbox"/> 10 years	
10. Calculation of Emissions:  <b>Detailed emission calculations are provided in Appendix A.</b>			
11. Potential, Fugitive, and Actual Emissions Comment:  <b>Excluding operations during emergency conditions, the emergency firewater pump diesel engine will operate up to 100 hours per year for routine testing and maintenance.</b>			

**F2. EMISSIONS UNIT POLLUTANT DETAIL INFORMATION -  
ALLOWABLE EMISSIONS**

Complete if the pollutant identified in Subsection F1 is or would be subject to a numerical emissions limitation.

**Allowable Emissions** Allowable Emissions 1 of 1

1. Basis for Allowable Emissions Code: <b>RULE (BACT)</b>	2. Future Effective Date of Allowable Emissions: <b>N/A</b>
3. Allowable Emissions and Units: <b>3.5 g/kWh</b>	4. Equivalent Allowable Emissions: <b>2.4 lb/hour      0.1 tons/year</b>
5. Method of Compliance: <b>Engine manufacturer certification per NSPS Subpart III.</b>	
6. Allowable Emissions Comment (Description of Operating Method): <b>Rule 62-212.400(4)(c), F.A.C.</b>	

**Allowable Emissions** Allowable Emissions    of

1. Basis for Allowable Emissions Code:	2. Future Effective Date of Allowable Emissions:
3. Allowable Emissions and Units:	4. Equivalent Allowable Emissions: lb/hour      tons/year
5. Method of Compliance:	
6. Allowable Emissions Comment (Description of Operating Method):	

**Allowable Emissions** Allowable Emissions    of

1. Basis for Allowable Emissions Code:	2. Future Effective Date of Allowable Emissions:
3. Allowable Emissions and Units:	4. Equivalent Allowable Emissions: lb/hour      tons/year
5. Method of Compliance:	
6. Allowable Emissions Comment (Description of Operating Method):	

**F1. EMISSIONS UNIT POLLUTANT DETAIL INFORMATION –  
POTENTIAL, FUGITIVE, AND ACTUAL EMISSIONS**

**(Optional for unregulated emissions units.)**

**Potential, Estimated Fugitive, and Baseline & Projected Actual Emissions**

**Complete for each pollutant identified in Subsection E if applying for an air construction permit or concurrent processing of an air construction permit and a revised or renewal Title V permit. Complete for each emissions-limited pollutant identified in Subsection E if applying for an air operation permit.**

1. Pollutant Emitted: <b>VOC</b>		2. Total Percent Efficiency of Control:	
3. Potential Emissions: <b>1.1 lb/hour                      0.05 tons/year</b>		4. Synthetically Limited? <input checked="" type="checkbox"/> Yes <input type="checkbox"/> No	
5. Range of Estimated Fugitive Emissions (as applicable): <b>N/A</b> to tons/year			
6. Emission Factor: <b>1.5 g/kWh</b>  Reference: <b>AP-42.</b>		7. Emissions Method Code: <b>3</b>	
8.a. Baseline Actual Emissions (if required): <b>N/A tons/year</b>		8.b. Baseline 24-month Period: <b>N/A</b> From:                      To:	
9.a. Projected Actual Emissions (if required): <b>N/A tons/year</b>		9.b. Projected Monitoring Period: <b>N/A</b> <input type="checkbox"/> 5 years <input type="checkbox"/> 10 years	
10. Calculation of Emissions:  <b>Detailed emission calculations are provided in Appendix A.</b>			
11. Potential, Fugitive, and Actual Emissions Comment:  <b>Excluding operations during emergency conditions, the emergency firewater pump diesel engine will operate up to 100 hours per year for routine testing and maintenance.</b>			

**F2. EMISSIONS UNIT POLLUTANT DETAIL INFORMATION -  
ALLOWABLE EMISSIONS N/A**

Complete if the pollutant identified in Subsection F1 is or would be subject to a numerical emissions limitation.

**Allowable Emissions** Allowable Emissions of

1. Basis for Allowable Emissions Code:	2. Future Effective Date of Allowable Emissions:
3. Allowable Emissions and Units:	4. Equivalent Allowable Emissions: lb/hour                      tons/year
5. Method of Compliance:	
6. Allowable Emissions Comment (Description of Operating Method):	

**Allowable Emissions** Allowable Emissions of

1. Basis for Allowable Emissions Code:	2. Future Effective Date of Allowable Emissions:
3. Allowable Emissions and Units:	4. Equivalent Allowable Emissions: lb/hour                      tons/year
5. Method of Compliance:	
6. Allowable Emissions Comment (Description of Operating Method):	

**Allowable Emissions** Allowable Emissions of

1. Basis for Allowable Emissions Code:	2. Future Effective Date of Allowable Emissions:
3. Allowable Emissions and Units:	4. Equivalent Allowable Emissions: lb/hour                      tons/year
5. Method of Compliance:	
6. Allowable Emissions Comment (Description of Operating Method):	



**F1. EMISSIONS UNIT POLLUTANT DETAIL INFORMATION –  
POTENTIAL, FUGITIVE, AND ACTUAL EMISSIONS**

**(Optional for unregulated emissions units.)**

**Potential, Estimated Fugitive, and Baseline & Projected Actual Emissions**

**Complete for each pollutant identified in Subsection E if applying for an air construction permit or concurrent processing of an air construction permit and a revised or renewal Title V permit. Complete for each emissions-limited pollutant identified in Subsection E if applying for an air operation permit.**

1. Pollutant Emitted: <b>SAM</b>		2. Total Percent Efficiency of Control:	
3. Potential Emissions: Neg. lb/hour                      Neg. tons/year		4. Synthetically Limited? <input checked="" type="checkbox"/> Yes <input type="checkbox"/> No	
5. Range of Estimated Fugitive Emissions (as applicable): <b>N/A</b> to tons/year			
6. Emission Factor: <b>N/A</b>  Reference: <b>ECT, 2007.</b>		7. Emissions Method Code: <b>2</b>	
8.a. Baseline Actual Emissions (if required): <b>N/A tons/year</b>		8.b. Baseline 24-month Period: <b>N/A</b> From:                                      To:	
9.a. Projected Actual Emissions (if required): <b>N/A tons/year</b>		9.b. Projected Monitoring Period: <b>N/A</b> <input type="checkbox"/> 5 years <input type="checkbox"/> 10 years	
10. Calculation of Emissions:  <b>Emergency generator diesel engine sulfuric acid mist emissions resulting from the combustion of ULSD fuel oil will be negligible.</b>			
11. Potential, Fugitive, and Actual Emissions Comment:  <b>Excluding operations during emergency conditions, the emergency firewater pump diesel engine will operate up to 100 hours per year for routine testing and maintenance.</b>			

F2. EMISSIONS UNIT POLLUTANT DETAIL INFORMATION -  
ALLOWABLE EMISSIONS

Complete if the pollutant identified in Subsection F1 is or would be subject to a numerical emissions limitation.

Allowable Emissions Allowable Emissions 1 of 1

1. Basis for Allowable Emissions Code: <b>RULE (BACT)</b>	2. Future Effective Date of Allowable Emissions: N/A
3. Allowable Emissions and Units: <b>0.0015 % S fuel oil</b>	4. Equivalent Allowable Emissions: N/A lb/hour      N/A tons/year
5. Method of Compliance: <b>Fuel oil analysis for sulfur content.</b>	
6. Allowable Emissions Comment (Description of Operating Method):  <b>Rule 62-212.400(4)(c), F.A.C.</b>	

Allowable Emissions Allowable Emissions      of

1. Basis for Allowable Emissions Code:	2. Future Effective Date of Allowable Emissions:
3. Allowable Emissions and Units:	4. Equivalent Allowable Emissions: lb/hour      tons/year
5. Method of Compliance:	
6. Allowable Emissions Comment (Description of Operating Method):	

Allowable Emissions Allowable Emissions      of

1. Basis for Allowable Emissions Code:	2. Future Effective Date of Allowable Emissions:
3. Allowable Emissions and Units:	4. Equivalent Allowable Emissions: lb/hour      tons/year
5. Method of Compliance:	
6. Allowable Emissions Comment (Description of Operating Method):	

**EMISSIONS UNIT INFORMATION**

Section [ 10 ] of [ 10 ]

**G. VISIBLE EMISSIONS INFORMATION**

Complete if this emissions unit is or would be subject to a unit-specific visible emissions limitation.

**Visible Emissions Limitation:** Visible Emissions Limitation 1 of 2

1. Visible Emissions Subtype: <b>VE20</b>	2. Basis for Allowable Opacity: <input checked="" type="checkbox"/> Rule <input type="checkbox"/> Other
3. Allowable Opacity: Normal Conditions: <b>20 %</b> Exceptional Conditions: % Maximum Period of Excess Opacity Allowed: min/hour	
4. Method of Compliance: <b>EPA Reference Method 9</b>	
5. Visible Emissions Comment:  <b>Rule 62-296.320(4)(b), F.A.C.</b>	

**Visible Emissions Limitation:** Visible Emissions Limitation 2 of 2

1. Visible Emissions Subtype: <b>VE99</b>	2. Basis for Allowable Opacity: <input checked="" type="checkbox"/> Rule <input type="checkbox"/> Other
3. Allowable Opacity: Normal Conditions: % Exceptional Conditions: % Maximum Period of Excess Opacity Allowed: <b>60 min/hour</b>	
4. Method of Compliance: <b>EPA Reference Method 9</b>	
5. Visible Emissions Comment:  <b>Excess emissions resulting from startup, shutdown or malfunction of any emissions unit shall be permitted providing (1) best operational practices to minimize emissions are adhered to and (2) the duration of excess emissions shall be minimized but in no case exceed two hours in any 24 hour period unless specifically authorized by the Department for longer duration.</b>  <b>Rule 62-210.700(1), F.A.C.</b>	

**EMISSIONS UNIT INFORMATION**

Section [ 10 ] of [ 10 ]

**H. CONTINUOUS MONITOR INFORMATION – N/A**

**Complete if this emissions unit is or would be subject to continuous monitoring.**

**Continuous Monitoring System:** Continuous Monitor of

1. Parameter Code:	2. Pollutant(s):
3. CMS Requirement:	<input type="checkbox"/> Rule <input type="checkbox"/> Other
4. Monitor Information Manufacturer: Model Number: Serial Number:	
5. Installation Date:	6. Performance Specification Test Date:
7. Continuous Monitor Comment:	

**Continuous Monitoring System:** Continuous Monitor of

1. Parameter Code:	2. Pollutant(s):
3. CMS Requirement:	<input type="checkbox"/> Rule <input type="checkbox"/> Other
4. Monitor Information Manufacturer: Model Number: Serial Number:	
5. Installation Date:	6. Performance Specification Test Date:
7. Continuous Monitor Comment:	

**EMISSIONS UNIT INFORMATION**

Section [ 10 ] of [ 10 ]

**I. EMISSIONS UNIT ADDITIONAL INFORMATION**

**Additional Requirements for All Applications, Except as Otherwise Stated**

<p>1. Process Flow Diagram (Required for all permit applications, except Title V air operation permit revision applications if this information was submitted to the department within the previous five years and would not be altered as a result of the revision being sought)</p> <p><input checked="" type="checkbox"/> Attached, Document ID: <u>Fig. 2-4</u>    <input type="checkbox"/> Previously Submitted, Date _____</p>
<p>2. Fuel Analysis or Specification (Required for all permit applications, except Title V air operation permit revision applications if this information was submitted to the department within the previous five years and would not be altered as a result of the revision being sought)</p> <p><input checked="" type="checkbox"/> Attached, Document ID: <u>Section 2.2, Table 2-5</u></p>
<p>3. Detailed Description of Control Equipment (Required for all permit applications, except Title V air operation permit revision applications if this information was submitted to the department within the previous five years and would not be altered as a result of the revision being sought)</p> <p><input checked="" type="checkbox"/> Attached, Document ID: <u>Section 2.0</u>    <input type="checkbox"/> Previously Submitted, Date _____</p>
<p>4. Procedures for Startup and Shutdown (Required for all operation permit applications, except Title V air operation permit revision applications if this information was submitted to the department within the previous five years and would not be altered as a result of the revision being sought)</p> <p><input checked="" type="checkbox"/> Not Applicable (construction application)</p>
<p>5. Operation and Maintenance Plan (Required for all permit applications, except Title V air operation permit revision applications if this information was submitted to the department within the previous five years and would not be altered as a result of the revision being sought)</p> <p><input type="checkbox"/> Attached, Document ID: _____    <input type="checkbox"/> Previously Submitted, Date _____</p> <p><input checked="" type="checkbox"/> Not Applicable</p>
<p>6. Compliance Demonstration Reports/Records</p> <p><input type="checkbox"/> Attached, Document ID: _____</p> <p>    Test Date(s)/Pollutant(s) Tested: _____</p> <p><input type="checkbox"/> Previously Submitted, Date: _____</p> <p>    Test Date(s)/Pollutant(s) Tested: _____</p> <p><input type="checkbox"/> To be Submitted, Date (if known): _____</p> <p>    Test Date(s)/Pollutant(s) Tested: _____</p> <p><input checked="" type="checkbox"/> Not Applicable</p> <p>Note: For FESOP applications, all required compliance demonstration records/reports must be submitted at the time of application. For Title V air operation permit applications, all required compliance demonstration reports/records must be submitted at the time of application, or a compliance plan must be submitted at the time of application.</p>
<p>7. Other Information Required by Rule or Statute</p> <p><input type="checkbox"/> Attached, Document ID: _____    <input checked="" type="checkbox"/> Not Applicable</p>

**EMISSIONS UNIT INFORMATION**

Section [ 10 ] of [ 10 ]

**Additional Requirements for Air Construction Permit Applications**

1. Control Technology Review and Analysis (Rules 62-212.400(10) and 62-212.500(7), F.A.C.; 40 CFR 63.43(d) and (e)) <input checked="" type="checkbox"/> Attached, Document ID: <u>Section 5.0</u> <input type="checkbox"/> Not Applicable
2. Good Engineering Practice Stack Height Analysis (Rule 62-212.400(4)(d), F.A.C., and Rule 62-212.500(4)(f), F.A.C.) <input checked="" type="checkbox"/> Attached, Document ID: <u>Section 6.0</u> <input type="checkbox"/> Not Applicable
3. Description of Stack Sampling Facilities (Required for proposed new stack sampling facilities only) <input type="checkbox"/> Attached, Document ID: _____ <input checked="" type="checkbox"/> Not Applicable

**Additional Requirements for Title V Air Operation Permit Applications** **NOT APPLICABLE**

1. Identification of Applicable Requirements <input type="checkbox"/> Attached, Document ID: _____
2. Compliance Assurance Monitoring <input type="checkbox"/> Attached, Document ID: _____ <input type="checkbox"/> Not Applicable
3. Alternative Methods of Operation <input type="checkbox"/> Attached, Document ID: _____ <input type="checkbox"/> Not Applicable
4. Alternative Modes of Operation (Emissions Trading) <input type="checkbox"/> Attached, Document ID: _____ <input type="checkbox"/> Not Applicable
5. Acid Rain Part Application <input type="checkbox"/> Certificate of Representation (EPA Form No. 7610-1) <input type="checkbox"/> Copy Attached, Document ID: _____ <input type="checkbox"/> Acid Rain Part (Form No. 62-210.900(1)(a)) <input type="checkbox"/> Attached, Document ID: _____ <input type="checkbox"/> Previously Submitted, Date: _____ <input type="checkbox"/> Repowering Extension Plan (Form No. 62-210.900(1)(a)1.) <input type="checkbox"/> Attached, Document ID: _____ <input type="checkbox"/> Previously Submitted, Date: _____ <input type="checkbox"/> New Unit Exemption (Form No. 62-210.900(1)(a)2.) <input type="checkbox"/> Attached, Document ID: _____ <input type="checkbox"/> Previously Submitted, Date: _____ <input type="checkbox"/> Retired Unit Exemption (Form No. 62-210.900(1)(a)3.) <input type="checkbox"/> Attached, Document ID: _____ <input type="checkbox"/> Previously Submitted, Date: _____ <input type="checkbox"/> Phase II NOx Compliance Plan (Form No. 62-210.900(1)(a)4.) <input type="checkbox"/> Attached, Document ID: _____ <input type="checkbox"/> Previously Submitted, Date: _____ <input type="checkbox"/> Phase II NOx Averaging Plan (Form No. 62-210.900(1)(a)5.) <input type="checkbox"/> Attached, Document ID: _____ <input type="checkbox"/> Previously Submitted, Date: _____ <input type="checkbox"/> Not Applicable

**EMISSIONS UNIT INFORMATION**

**Section [ 10 ] of [ 10 ]**

**Additional Requirements Comment**

[Empty rectangular box for Additional Requirements Comment]

**Polk Power Station Unit 6 IGCC  
Class I Area Dispersion Modeling Files**

Directory Name	No. of Files	File Name	File Description
CLASS I/PUFF-INP	3	U6YY.INP YY = 01, 02, and 03	CALPUFF input files
CLASS I/PUFF-OUT	3	U6YY.CON	CALPUFF output concentration files
	3	U6DFYY.CON	CALPUFF output concentration files, dry deposition flux files
	3	U6WFYY.CON	CALPUFF output concentration files, wet deposition flux files
	3	U6YY.LST	CALPUFF output concentration list files
	3	VISYY.ZIP YY = 01, 02, and 03	CALPUFF output visibility relative humidity (RH) files
Subtotal Files	15		
CLASS I/UTIL-INP	3	U6YYP1.INP	POSTUTIL input files, NO <sub>2</sub> /HNO <sub>3</sub> Repartition
	3	U6YYP2.INP	POSTUTIL input files, PM <sub>10</sub> and Visibility Species Processing
	3	U6YYP3.INP YY = 01, 02, and 03	POSTUTIL input files, Nitrogen and Sulfur Deposition
Subtotal Files	9		
CLASS I/UTIL-OUT	3	U6YYP1.CON	POSTUTIL output concentration files, NO <sub>2</sub> /HNO <sub>3</sub> Repartition
	3	U6YYP2.CON	POSTUTIL output concentration files, PM <sub>10</sub> and Visibility Species Processing
	3	U6YYTDEP.CON	POSTUTIL output concentration files, Nitrogen and Sulfur Deposition
	3	U6YYP1.LST	POSTUTIL output list files, NO <sub>2</sub> /HNO <sub>3</sub> Repartition
	3	U6YYP2.LST	POSTUTIL output list files, PM <sub>10</sub> and Visibility Species Processing
	3	U6YYTDEP.LST YY = 01, 02, and 03	POSTUTIL output list files, Nitrogen and Sulfur Deposition
Subtotal Files	18		
CLASS I/POST-INP	3	U6NO2CHYY.INP	CALPOST input NO <sub>2</sub> files - Chassahowitzka NWA
	3	U6PMCHYY.INP	CALPOST input PM <sub>10</sub> files - - Chassahowitzka NWA
	3	U6SO2CHYY.INP	CALPOST input SO <sub>2</sub> files - - Chassahowitzka NWA
	3	U6NDCHYY.INP	CALPOST input nitrogen deposition files - Chassahowitzka NWA
	3	U6SDCHYY.INP	CALPOST input sulfur deposition files - Chassahowitzka NWA
	3	U6V1CHYY.INP	CALPOST input visibility files; Method 2 - Chassahowitzka NWA
	3	U6V2CHYY.INP	CALPOST input visibility files; Method 6 - Chassahowitzka NWA
	3	U6NO2EVYY.INP	CALPOST input NO <sub>2</sub> files - Everglades NP
	3	U6PMEVYY.INP	CALPOST input PM <sub>10</sub> files - - Everglades NP
	3	U6SO2EVYY.INP	CALPOST input SO <sub>2</sub> files - - Everglades NP
	3	U6NDEVYY.INP	CALPOST input nitrogen deposition files - Everglades NP
	3	U6SDEVYY.INP	CALPOST input sulfur deposition files - Everglades NP
	3	U6V1EVYY.INP	CALPOST input visibility files; Method 2 - Everglades NP
	3	U6V2EVYY.INP YY = 01, 02, and 03	CALPOST input visibility files; Method 6 - Everglades NP
Subtotal Files	42		
CLASS I/POST-OUT	3	U6NO2CHYY.OUT	CALPOST output NO <sub>2</sub> files - Chassahowitzka NWA
	3	U6PMCHYY.OUT	CALPOST output PM <sub>10</sub> files - - Chassahowitzka NWA
	3	U6SO2CHYY.OUT	CALPOST output SO <sub>2</sub> files - - Chassahowitzka NWA
	3	U6NDCHYY.OUT	CALPOST output nitrogen deposition files - Chassahowitzka NWA
	3	U6SDCHYY.OUT	CALPOST output sulfur deposition files - Chassahowitzka NWA
	3	U6V1CHYY.OUT	CALPOST output visibility files; Method 2 - Chassahowitzka NWA
	3	U6V2CHYY.OUT	CALPOST output visibility files; Method 6 - Chassahowitzka NWA
	3	U6NO2EVYY.OUT	CALPOST output NO <sub>2</sub> files - Everglades NP
	3	U6PMEVYY.OUT	CALPOST output PM <sub>10</sub> files - - Everglades NP
	3	U6SO2EVYY.OUT	CALPOST output SO <sub>2</sub> files - - Everglades NP
	3	U6NDEVYY.OUT	CALPOST output nitrogen deposition files - Everglades NP
	3	U6SDEVYY.OUT	CALPOST output sulfur deposition files - Everglades NP
	3	U6V1EVYY.OUT	CALPOST output visibility files; Method 2 - Everglades NP
	3	U6V2EVYY.OUT YY = 01, 02, and 03	CALPOST output visibility files; Method 6 - Everglades NP
Subtotal Files	42		
Total Files	129		



**Polk Power Station Unit 6 IGCC  
Class II Area Dispersion Modeling Files**

Directory Name	No. of Files	File Name	File Description
AERMOD MET DATA	5	MCOTPAYY.PFL	Meteorological Data - Orlando Intl. Airport Surface and Tampa Intl. Airport Upper Air profile files
	5	MCOTPAYY.SFC YY = 99 - 03	Meteorological Data - Orlando Intl. Airport Surface and Tampa Intl. Airport Upper Air surface files
Subtotal Files	10		
GEP	1	U6.BPI	Building Profile Input Program (BPIP) input file
	1	U6.PRO	Building Profile Input Program (BPIP) output file
Subtotal Files	2		
AERMOD INPUT	5	CO_YY.INP	AERMOD input files; 1- and 8-Hour Average Carbon Monoxide (CO)
	5	NO2_YY.INP	AERMOD input files; Annual Average Nitrogen Dioxide (NO <sub>2</sub> )
	5	SO2_YY.INP	AERMOD input files; 3-, 8-, and 24-Hour and Annual Average Sulfur Dioxide (SO <sub>2</sub> )
	5	PM_YY.INP	AERMOD input files; 24-Hour and Annual Average Particulate Matter (PM <sub>10</sub> )
	1	U6.ROU YY = 99 - 03	AERMOD input file; Receptor File
Subtotal files	21		
AERMOD OUTPUT	5	CO_YY.OUT	AERMOD output files; 1- and 8-Hour Average Carbon Monoxide (CO)
	5	NO2_YY.OUT	AERMOD output files; Annual Average Nitrogen Dioxide (NO <sub>2</sub> )
	5	SO2_YY.OUT	AERMOD output files; 3-, 8-, and 24-Hour and Annual Average Sulfur Dioxide (SO <sub>2</sub> )
	5	PM_YY.OUT	AERMOD output files; 24-Hour and Annual Average Particulate Matter (PM <sub>10</sub> )
		YY = 99 - 03	
Subtotal files	20		
Total Files	53		

Source: ECT, 2007.

## Appendix D – Analysis of Class II Meteorological Data

1. AERSURFACE Surface Characteristics
2. Orlando International Airport Land Use (Figure D-1A)
3. Orlando International Airport Land Use Legend (Figure D-1B)
4. Orlando International Airport Aerial (Figure D-2)
5. Tampa International Airport Land Use (Figure D-3)
6. Tampa International Airport Aerial (Figure D-4)
7. Polk Power Station Land Use (Figure D-5)
8. Polk Power Station Aerial (Figure D-6)

# AERSURFACE Surface Characteristics

## A-3. Seasonal Values of Surface Roughness for the NLCD 92 21-Land Use Classification System

Ser	Class Name	Seasonal Surface Roughness <sup>1</sup> (m)					Reference
		1	2	3	4	5	
11	Open Water	0.001	0.001	0.001	0.001	0.001	Stull <sup>2</sup>
12	Perennial Ice/Snow	0.002	0.002	0.002	0.002	0.002	Stull <sup>2</sup>
21	Low Intensity Residential	0.77	0.77	0.65	0.63	0.72	$(22+43+85)/3^3$
22	High Intensity Residential	1	1	1	1	1	AERMET <sup>4</sup>
23	Commercial/Industrial/Transp (Site at Airport)	0.1	0.1	0.1	0.1	0.1	5%: 22 & 95%: 31 <sup>5</sup>
	Commercial/Industrial/Transp (Not at Airport)	0.8	0.8	0.8	0.8	0.8	80%: 22 & 20%: 31 <sup>5</sup>
31	Bare Rock/Sand/Clay (Arid Region)	0.05	0.05	0.05	NA	0.05	Slade <sup>6</sup>
	Bare Rock/Sand/Clay (Non-arid Region)	0.05	0.05	0.05	0.05	0.05	Slade <sup>6</sup>
32	Quarries/Strip Mines/Gravel	0.3	0.3	0.3	0.3	0.3	Estimate <sup>7</sup>
33	Transitional	0.2	0.2	0.2	0.2	0.2	Estimate <sup>8</sup>
41	Deciduous Forest	1.3	1.3	0.6	0.5	1	AERMET <sup>4</sup>
42	Evergreen Forest	1.3	1.3	1.3	1.3	1.3	AERMET <sup>4</sup>
43	Mixed Forest	1.3	1.3	0.95	0.9	1.15	$(41+42)/2^9$
51	Shrubland (Arid Region)	0.15	0.15	0.15	NA	0.15	50% 51 (Non-Arid) <sup>10</sup>
	Shrubland (Non-arid Region)	0.3	0.3	0.3	0.15	0.3	AERMET <sup>4</sup>
51	Orchards/Vineyards/Other	0.3	0.3	0.1	0.05	0.2	Garratt <sup>11</sup>
71	Grasslands/Herbaceous	0.1	0.1	0.01	0.005	0.05	AERMET <sup>4</sup>
31	Pasture/Hay	0.15	0.15	0.02	0.01	0.03	Garratt <sup>11</sup> & Slade <sup>12</sup>
32	Row Crops	0.2	0.2	0.02	0.01	0.03	Garratt <sup>11</sup> & Slade <sup>12</sup>
33	Small Grains	0.15	0.15	0.02	0.01	0.03	Garratt <sup>11</sup> & Slade <sup>12</sup>
34	Fallow	0.05	0.05	0.02	0.01	0.02	31 & 81,82,83 <sup>13</sup>
35	Urban/Recreational Grasses	0.02	0.015	0.01	0.005	0.015	Randerson <sup>14</sup>
91	Woody Wetlands	0.7	0.7	0.6	0.5	0.7	$(43+92)/2^{15}$
92	Emergent Herbaceous Wetlands	0.2	0.2	0.2	0.1	0.2	AERMET <sup>4</sup>

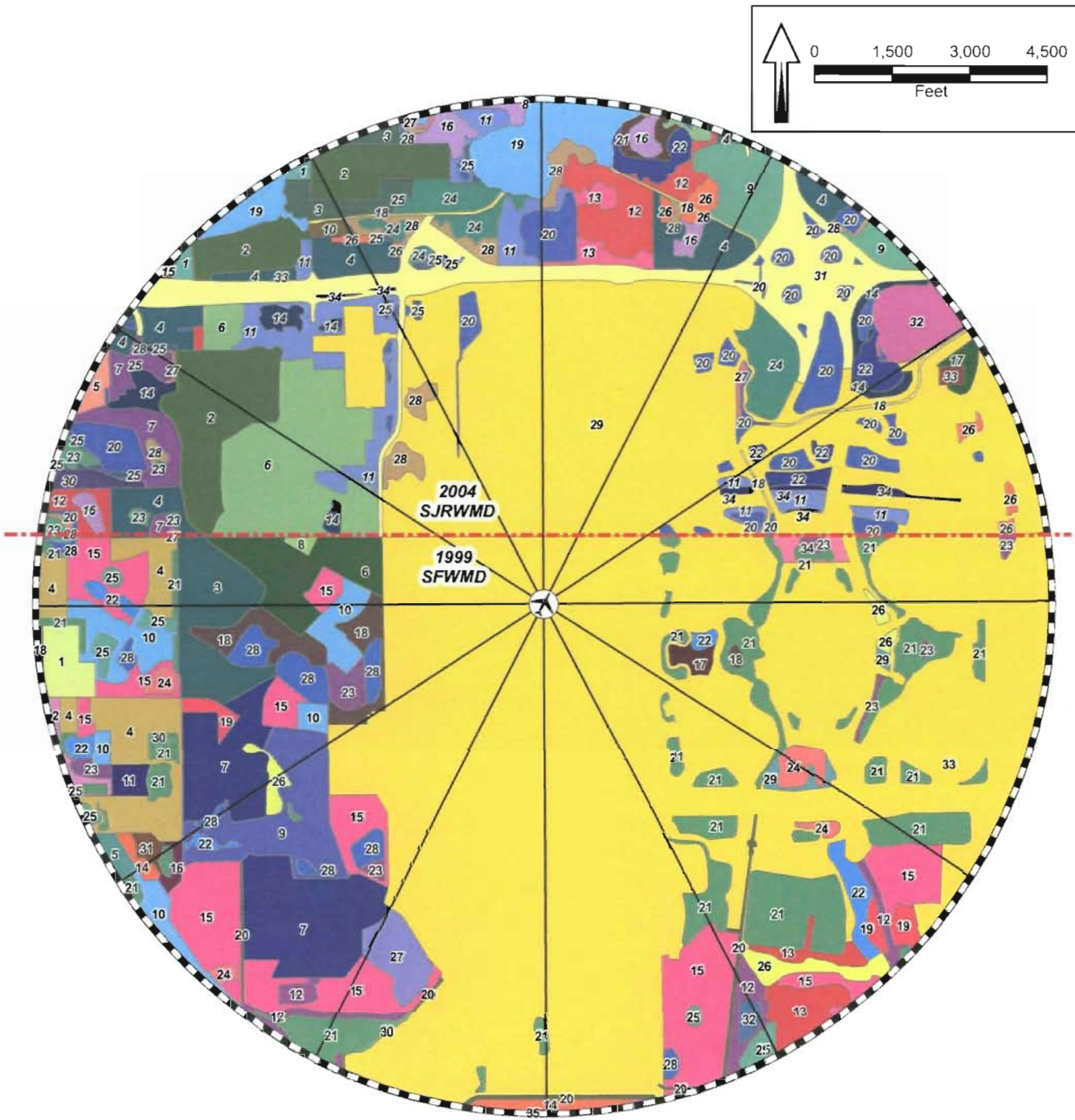

**Legend**

-  Orlando International Airport
-  3km Buffer of Airport
-  Sectors

FIGURE D-1A.  
2004 SJRWMD/1999 SFWMD FLUCFCS  
ORLANDO INTERNATIONAL AIRPORT

Sources: Labins, 2004; Tampa Electric, 2007; ECT, 2007.



### LEGEND APPENDIX

#### 2004 SJRWMD FLUCFCS/MAP KEY, DESCRIPTION

	1, 1100: Residential, low density - less than 2 dwelling units/acre
	2, 1200: Residential, medium density - 2-5 dwelling units/acre
	3, 1300: Residential, high density - 6 or more dwelling units/acre
	4, 1400: Commercial and services
	5, 1550: Other light industrial
	6, 1700: Institutional
	7, 1900: Open land
	8, 2120: Unimproved pastures
	9, 2150: Field crops
	10, 2240: Abandoned tree crops
	11, 3100: Herbaceous upland nonforested
	12, 3200: Shrub and brushland (wax myrtle or saw palmetto, occasionally scrub oak)
	13, 3300: Mixed upland nonforested
	14, 4110: Pine flatwoods
	15, 4200: Upland hardwood forests
	16, 4340: Upland mixed coniferous/hardwood
	17, 4410: Coniferous pine
	18, 5100: Streams and waterways
	19, 5200: Lakes
	20, 5300: Reservoirs - pits, retention ponds, dams
	21, 6110: Bay swamp (if distinct)
	22, 6170: Mixed wetland hardwoods
	23, 6210: Cypress
	24, 6300: Wetland forested mixed
	25, 6410: Freshwater marshes
	26, 6430: Wet prairies
	27, 6440: Emergent aquatic vegetation
	28, 6460: Mixed scrub-shrub wetland
	29, 8110: Airports
	30, 8120: Railroads
	31, 8140: Roads and highways (divided 4-lanes with medians)
	32, 8180: Auto parking facilities
	33, 8310: Electrical power facilities
	34, 8370: Surface water collection ponds

#### 1999 SFWMD FLUCFCS/MAP KEY, DESCRIPTION

	1, 1210 - Medium Density: Fixed Single Family Units
	2, 1310 - High Density: Fixed Single Family Units
	3, 1330 - Multiple Dwelling Units, Low Rise
	4, 1400 - Commercial and Services
	5, 1550 - Other light industry
	6, 1700 - Institutional
	7, 1730 - Military
	8, 1800 - Recreational
	9, 1820 - Golf course
	10, 1900 - Open Land
	11, 2430 - Ornamentals
	12, 3100 - Herbaceous (Dry Prairie)
	13, 3200 - Upland Shrub and Brush land
	14, 3300 - Mixed Rangeland
	15, 4110 - Pine Flatwoods
	16, 4200 - Upland Hardwood Forest
	17, 4220 - Brazilian Pepper
	18, 4340 - Hardwood / Coniferous Mixed
	19, 4410 - Coniferous Plantations
	20, 5120 - Channelized Waterways, Canals
	21, 5300 - Reservoirs
	22, 6170 - Mixed wetland hardwoods
	23, 6172 - Mixed Shrubs
	24, 6210 - Cypress
	25, 6215 - Cypress - Domes/Heads
	26, 6216 - Cypress - Mixed Hardwoods
	27, 6250 - Wet Pinelands Hydric Pine
	28, 6300 - Wetland Forested Mixed
	29, 6410 - Freshwater Marshes / Graminoid Prairie-Marsh
	30, 6440 - Emergent aquatic vegetation
	31, 7400 - Disturbed land
	32, 7430 - Spoil areas
	33, 8110 - Airports
	34, 8140 - Roads and highways
	35, 8340 - Sewage treatment

FIGURE D-1B.  
2004 SJRWMD/1999 SFWMD FLUCFCS  
ORLANDO INTERNATIONAL AIRPORT

Sources: Labins, 2004; Tampa Electric, 2007; ECT, 2007.



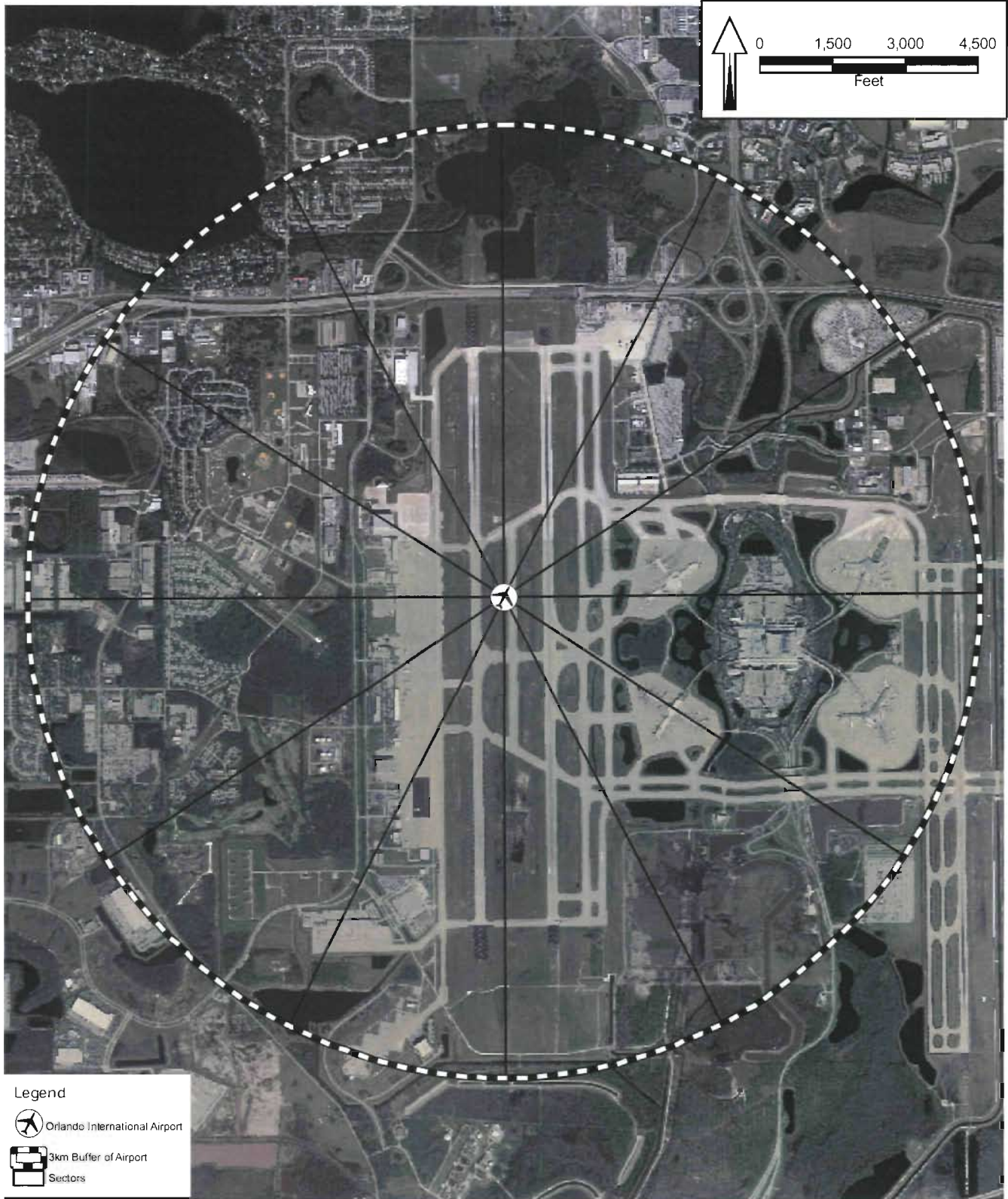
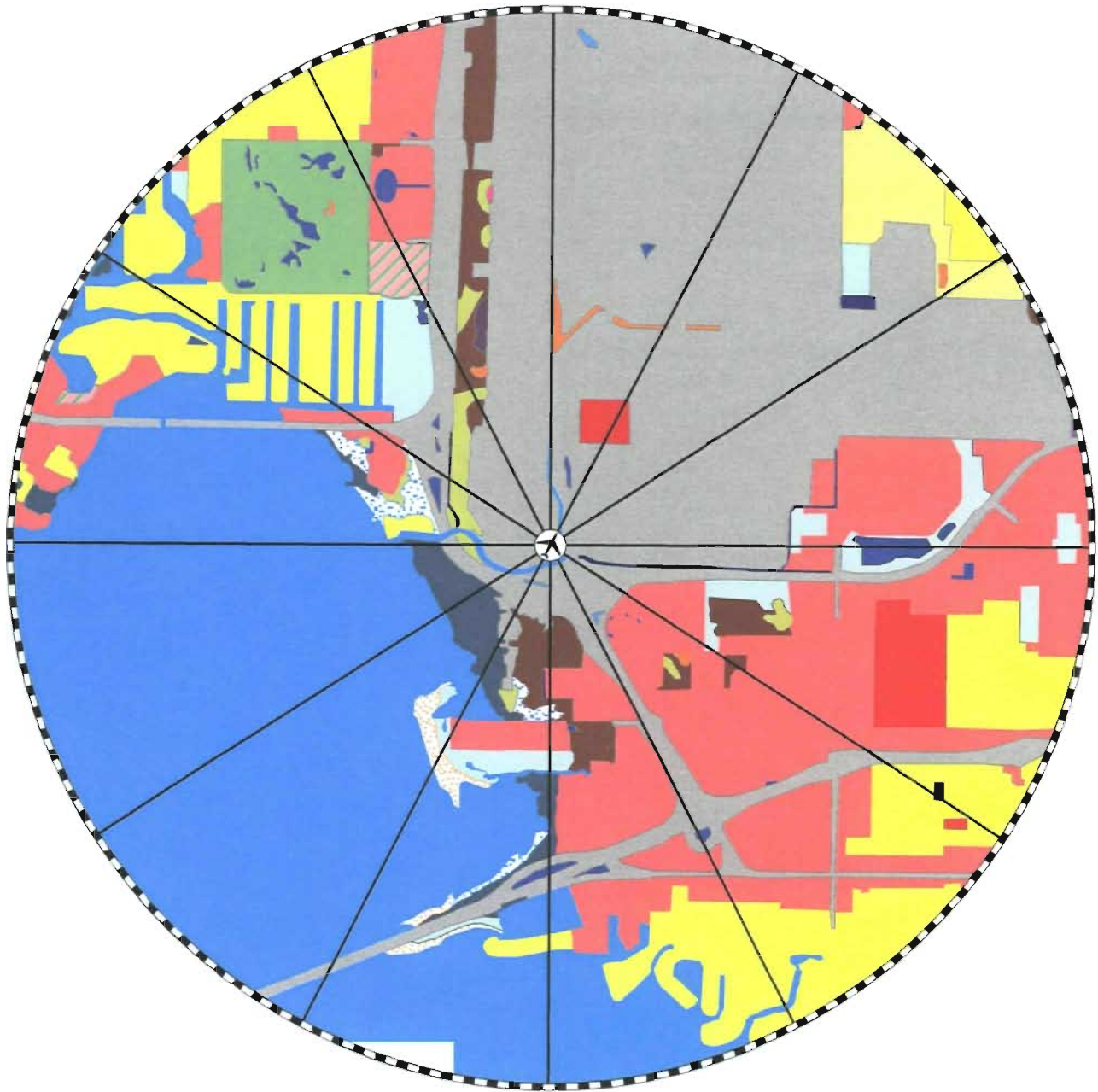

FIGURE D-2.

2004 AERIAL ORLANDO INTERNATIONAL AIRPORT

Sources: Labins, 2004; Tampa Electric, 2007; ECT, 2007.





Legend

- |                                |                           |                              |   |
|--------------------------------|---------------------------|------------------------------|---|
| Tampa International Airport    | 1500, INDUSTRIAL          | 4340, HARDWOOD CONIFER MIXED | 6420, SALTWATER MARSHES                   |
| 3km Buffer of Airport          | 1700, INSTITUTIONAL       | 5100, STREAMS AND WATERWAYS  | 6430, WET PRAIRIES                        |
| Sectors                        | 1800, RECREATIONAL        | 5300, RESERVOIRS             | 6440, EMERGENT AQUATIC VEGETATION         |
| <b>SWFWMD 2005 FLUCFCS</b>     | 1820, GOLF COURSES        | 5400, BAYS AND ESTUARIES     | 6530, INTERMITTENT PONDS                  |
| 1300, RESIDENTIAL HIGH DENSITY | 1900, OPEN LAND           | 6120, MANGROVE SWAMPS        | 7100, BEACHES OTHER THAN SWIMMING BEACHES |
| 1400, COMMERCIAL AND SERVICES  | 3200, SHRUB AND BRUSHLAND | 6300, WETLAND FORESTED MIXED | 8100, TRANSPORTATION                      |
|                                | 4110, PINE FLATWOODS      | 6410, FRESHWATER MARSHES     | 8300, UTILITIES                           |

FIGURE D-3.

2005 SWFWMD FLUCFCS TAMPA INTERNATIONAL AIRPORT

Sources: SWFWMD, 2005/2006; Tampa Electric, 2007; ECT, 2007.





FIGURE D-4.

2006 AERIAL TAMPA INTERNATIONAL AIRPORT

Sources: SWFWMD, 2005/2006; Tampa Electric, 2007; ECT, 2007.





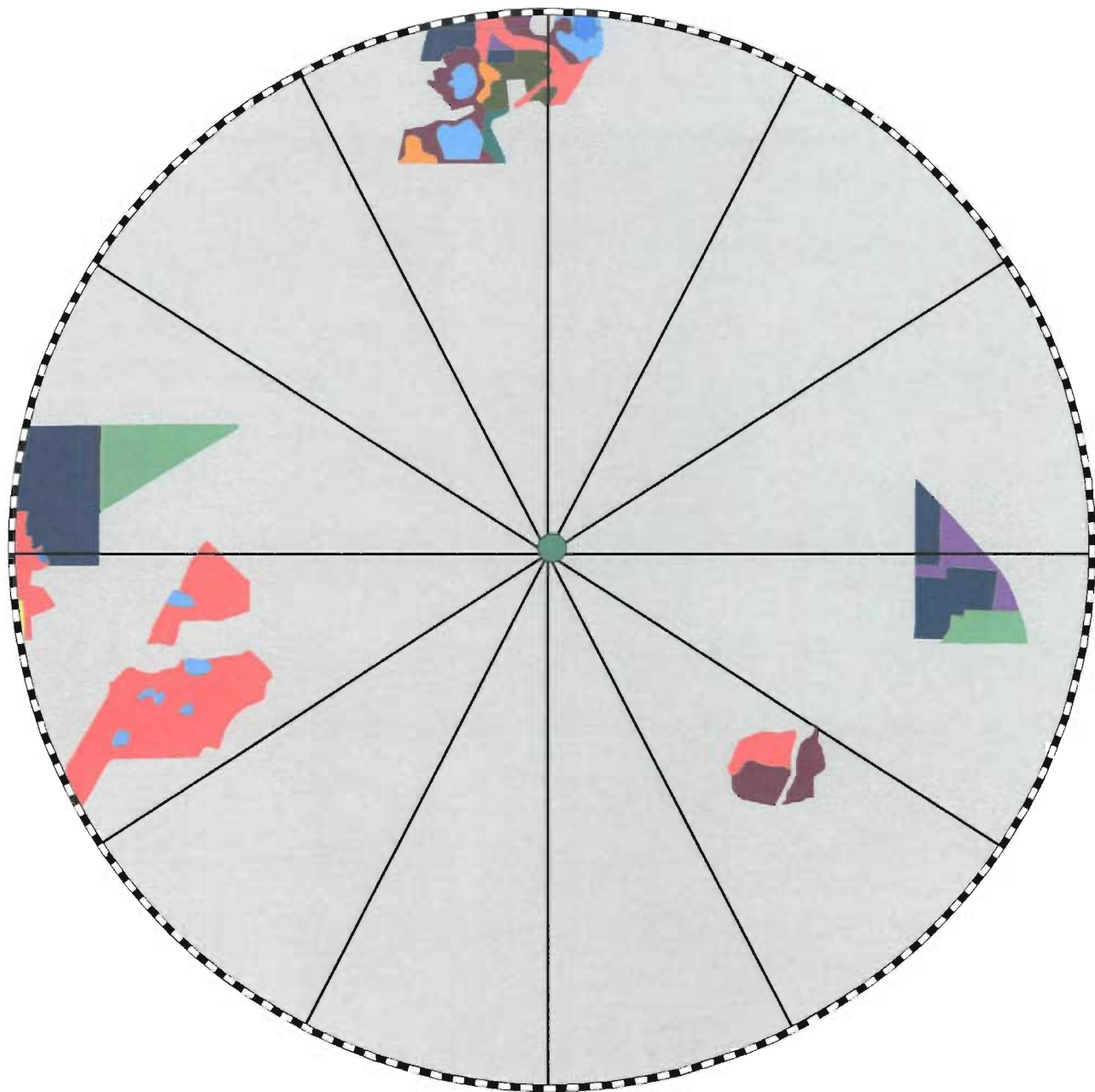

Legend

-  STACK
-  3km Buffer of Unit 6 Stack
-  Sectors
- 2005 SWFWMD FLUCFCS**
-  1100, RESIDENTIAL LOW DENSITY < 2 DWELLING UNITS
-  1600, EXTRACTIVE
-  2100, CROPLAND AND PASTURELAND
-  2200, TREE CROPS
-  2600, OTHER OPEN LANDS <RURAL>
-  3200, SHRUB AND BRUSHLAND
-  4200, UPLAND HARDWOOD FORESTS - PART 1
-  4340, HARDWOOD CONIFER MIXED
-  5300, RESERVOIRS
-  6150, STREAM AND LAKE SWAMPS (BOTTOMLAND)
-  6410, FRESHWATER MARSHES
-  6430, WET PRAIRIES

FIGURE D-5.

2005 SWFWMD FLUCFCS POLK POWER STATION

Sources: SWFWMD, 2005/2006; Tampa Electric, 2007; ECT, 2007.



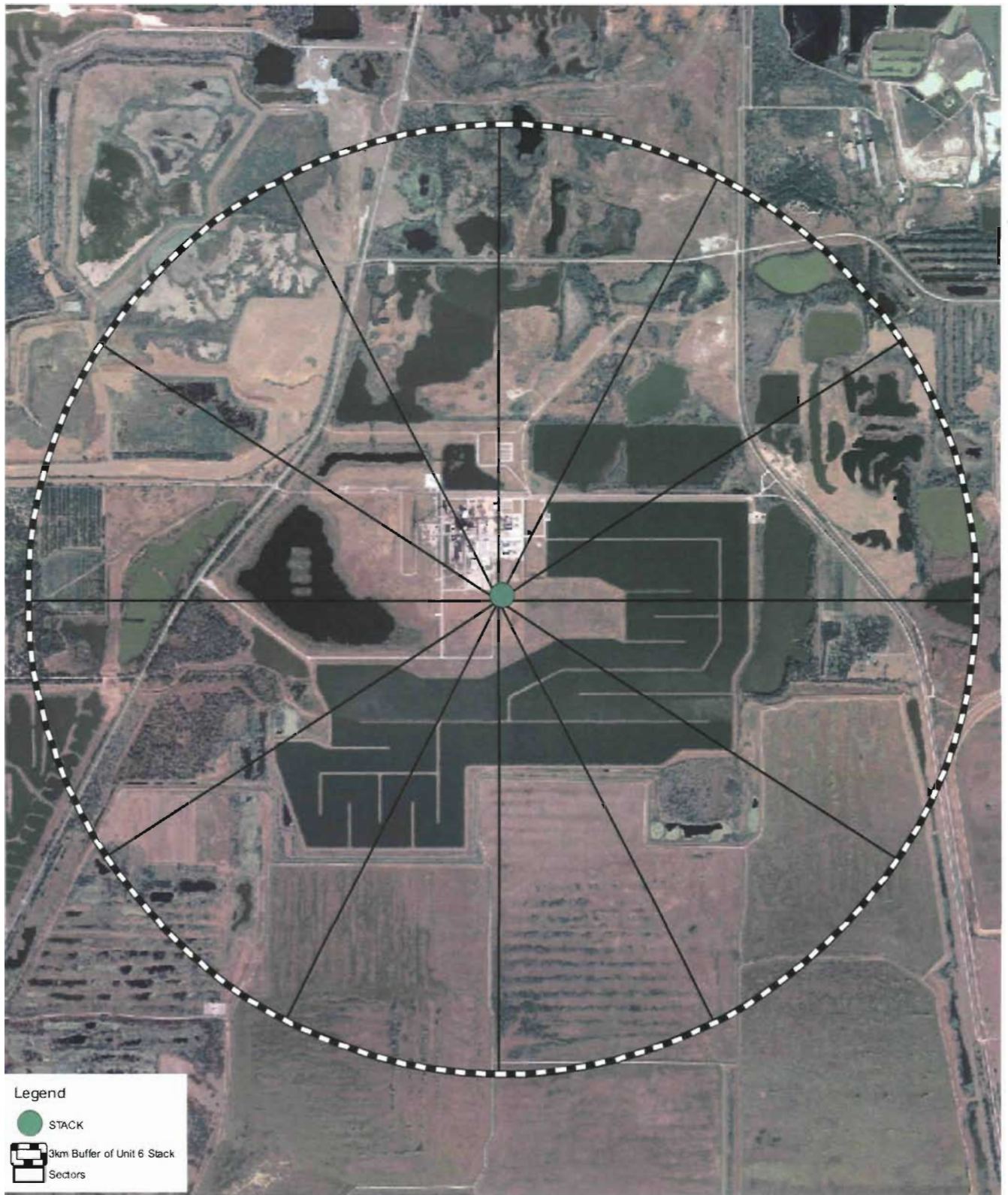

FIGURE D-6.

2006 AERIAL POLK POWER STATION

Sources: SWFWMD, 2005/2006; Tampa Electric, 2007; ECT, 2007.





TAMPA ELECTRIC

# POLK POWER STATION UNIT 6

BEST AVAILABLE COPY

AIR CONSTRUCTION/  
PREVENTION OF SIGNIFICANT  
DETERIORATION PERMIT  
APPLICATION

RECEIVED

SEP 11 2007

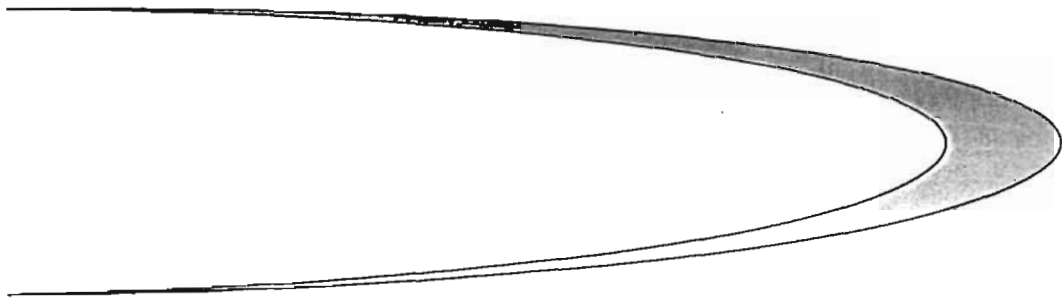
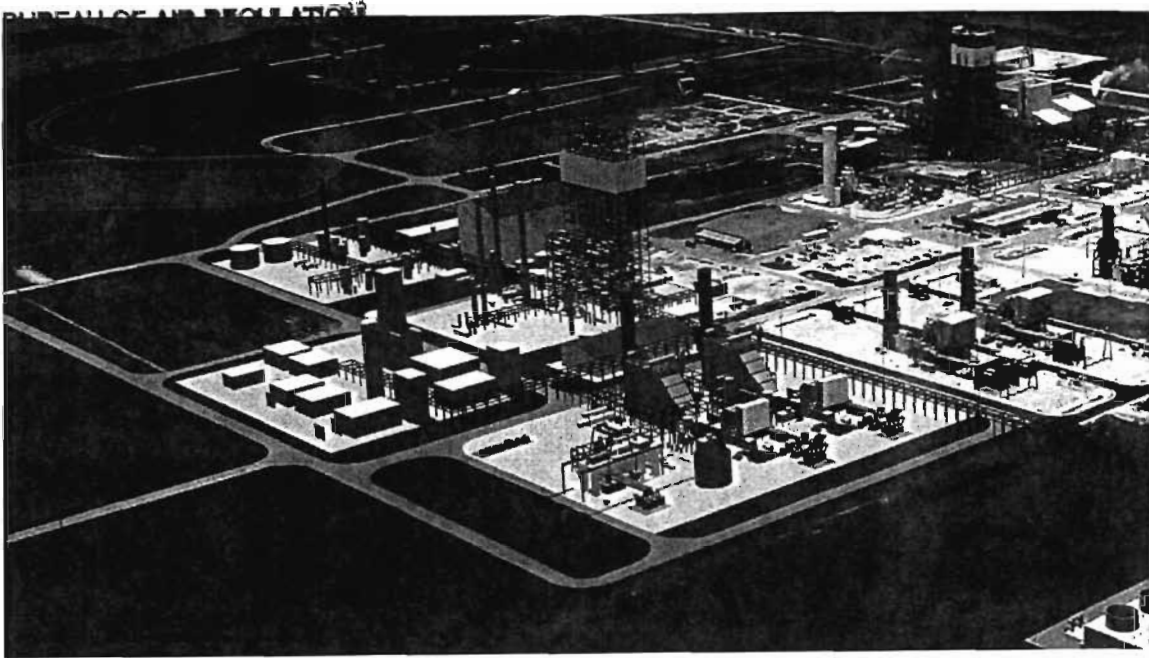

Prepared by:

**ECT**

Environmental Consulting & Technology, Inc.  
3701 Northwest 98<sup>th</sup> Street  
Gainesville, Florida 32606  
ECT No. 070040-0100

September 2007



FIGURE 2-1.  
OVERALL SITE LAYOUT OR EASTERN PORTION OF PPS SITE

Source: 2018 SWFWMD Aerials; Bechtel, 2007; ECT, 2007.



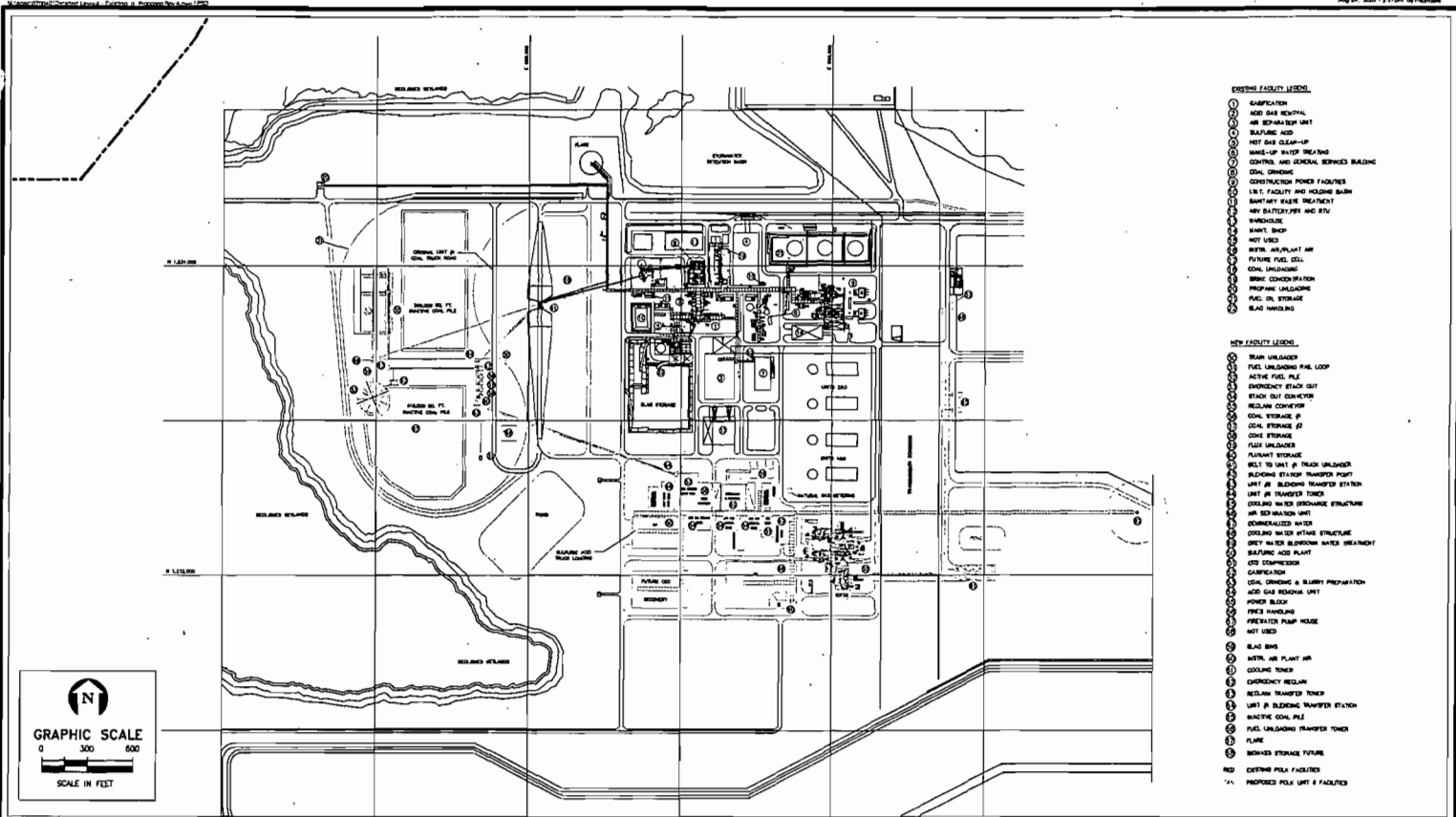

FIGURE 2-2.  
DETAILED LAYOUT OF EXISTING AND PROPOSED POLK UNIT 6 FACILITIES

Sources: Bechtel, 2007; ECT, 2007.



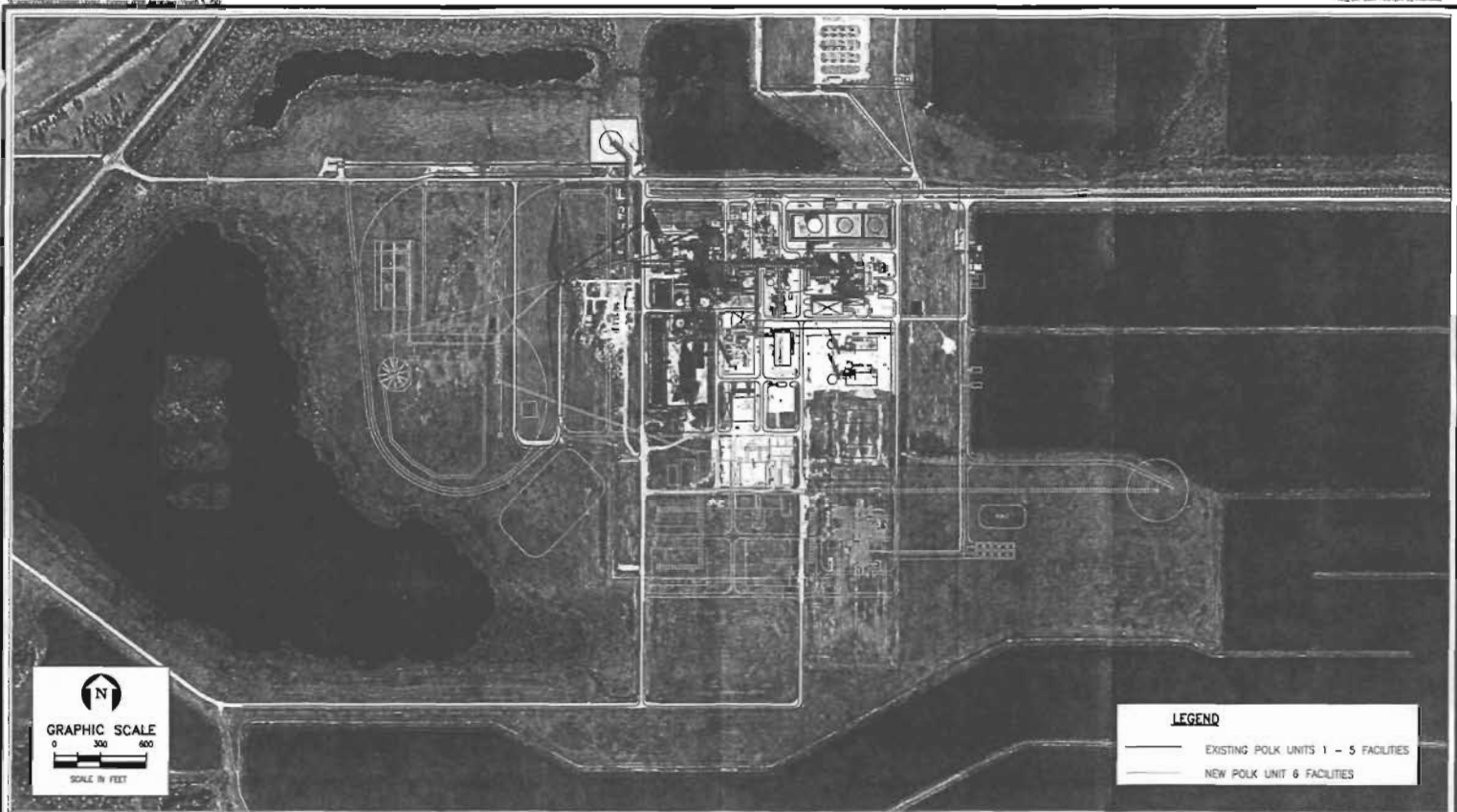
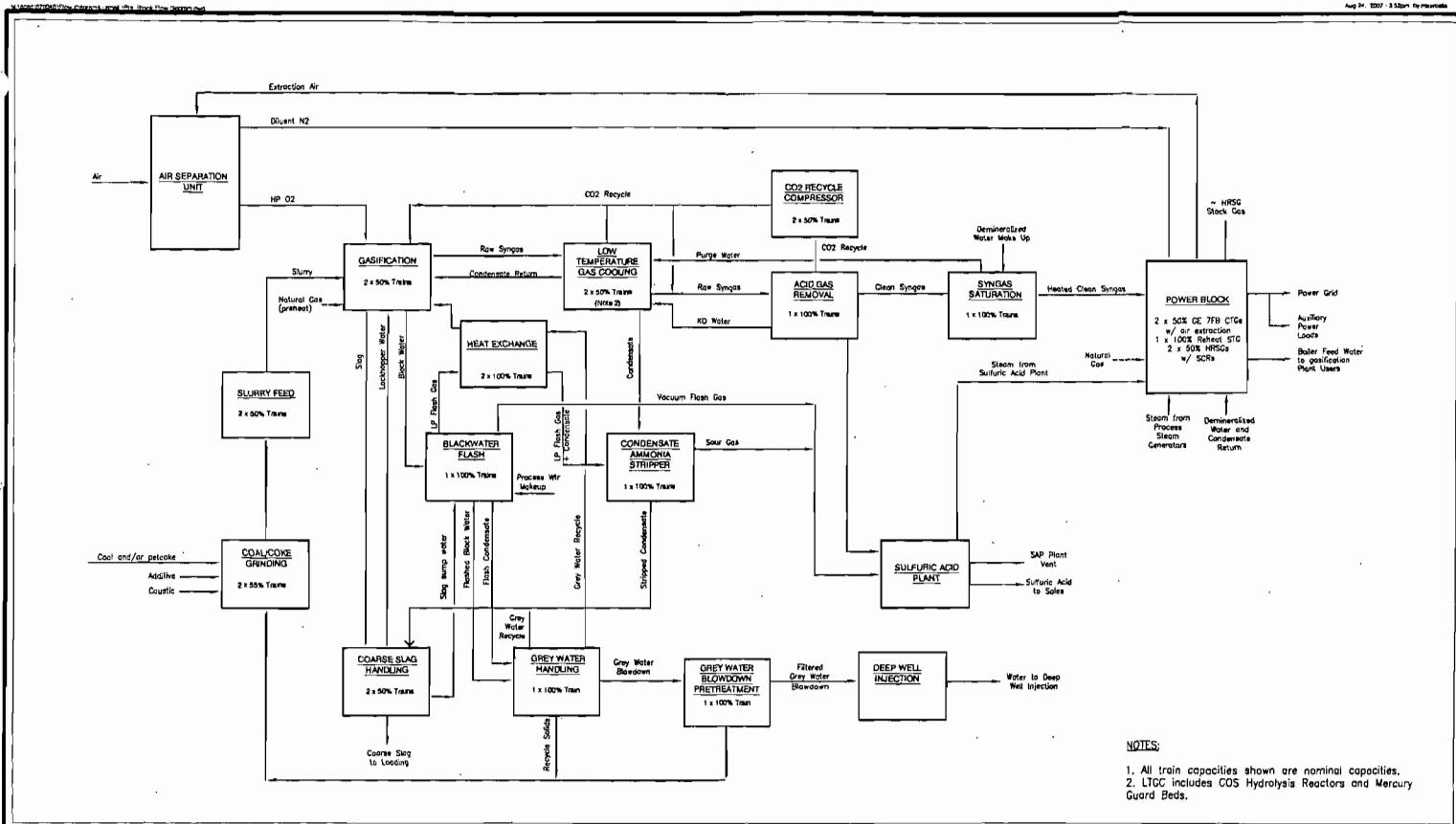

FIGURE 2-3.  
DETAILED LAYOUT OF FACILITIES ON AERIAL PHOTOGRAPH

Sources: 2006 SWFWMD Aerials; Bachtel, 2007; ECT, 2007.





NOTES:  
 1. All train capacities shown are nominal capacities.  
 2. LTGC includes COS Hydrolysis Reactors and Mercury Guard Beds.

FIGURE 2-4.  
 PRELIMINARY BLOCK FLOW DIAGRAM FOR POLK UNIT 6 PROJECT

Sources: GE Energy (USA) LLC, 2007.



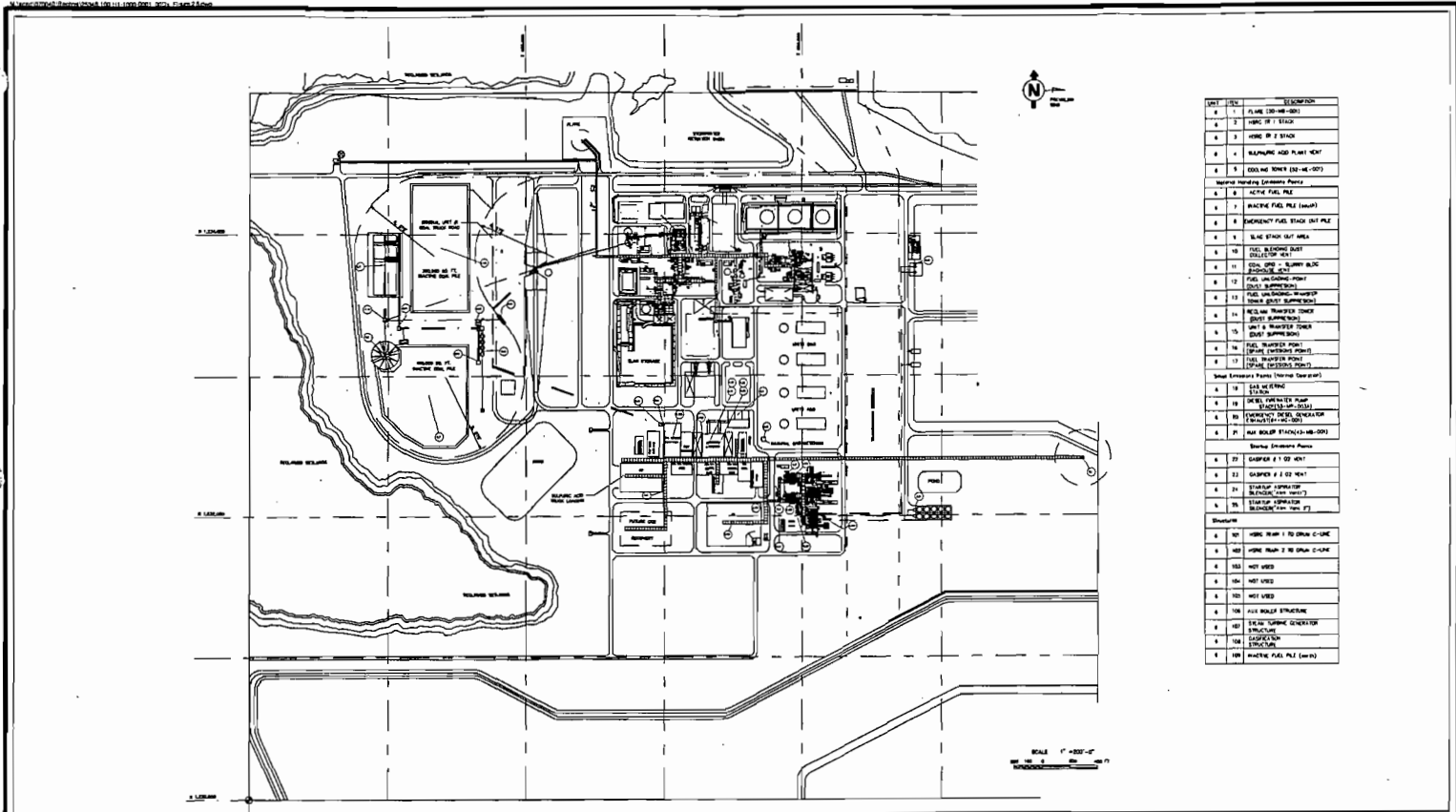

FIGURE 2-5.  
UNIT 6 - LOCATION OF AIR EMISSION SOURCES

Source: Bechtel, 2007; ECT, 2007.





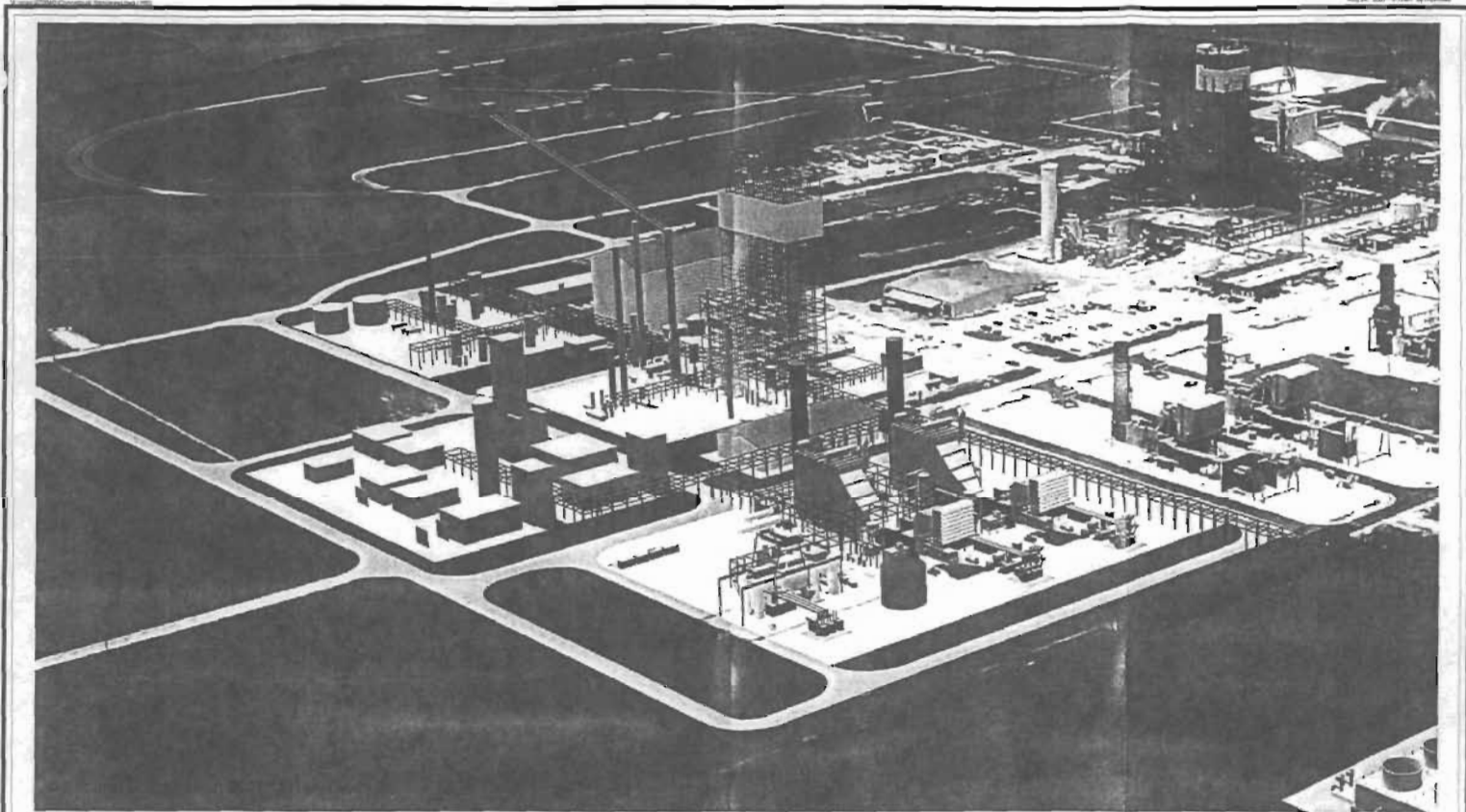

FIGURE 6-1.  
UNIT 6 THREE-DIMENSIONAL VIEW

Source: Bechtel Corporation, 2007.



**BEST AVAILABLE COPY**

**Table A-1. Polk Power Station Unit 6 IGCC  
Annual Emission Rate Summary**

Pollutant	Potential Annual Emissions (tpy)																Unit 6 Totals
	CT/HRSG Train 1	CT/HRSG Train 2	CT/HRSG Startup/Shutdown	Sulfuric Acid plant	Sulfuric Acid plant Startup/Shutdown	Auxiliary Boiler	Gasifier Preheat Train 1	Gasifier Preheat Train 2	Flare	Emergency Firewater Pump Diesel Engines	Emergency Generators Diesel Engine	Cooling Tower	Feedstock & Slag Storage Piles	Feedstock Handling Point Sources	Feedstock Handling Fugitive Sources		
<b>Criteria Pollutants</b>																	
NO <sub>x</sub>	433.6	433.6	44.6	Neg.	0.75	4.7	0.90	0.90	3.8	0.72	1.16	N/A	N/A	N/A	N/A	924.8	
CO	407.3	407.3	71.2	Neg.	0.66	4.7	0.76	0.76	18.0	0.24	0.63	N/A	N/A	N/A	N/A	909.6	
VOC	14.5	14.5	7.2	Neg.	0.043	1.4	0.050	0.050	0.052	0.11	0.078	N/A	N/A	N/A	N/A	37.9	
SO <sub>2</sub>	227.6	227.6	0.61	160.6	1.31	0.77	0.054	0.054	51.2	0.00051	0.0013	N/A	N/A	N/A	N/A	670.1	
PM <sub>10</sub> (filterable + condensable)	170.8	170.8	4.2	16.1	0.060	1.0	0.069	0.069	0.073	0.037	0.036	0.80	0.74	1.9	1.2	387.8	
Pb	0.054	0.054	Neg.	Neg.	N/A	Neg.	Neg.	Neg.	Neg.	Neg.	Neg.	N/A	N/A	N/A	N/A	0.11	
<b>Hazardous Air Pollutants<sup>1</sup></b>																	
Hydrogen Chloride	1.1	1.1	Neg.	Neg.	Neg.	Neg.	Neg.	Neg.	Neg.	Neg.	Neg.	N/A	N/A	N/A	N/A	2.3	
Total HAPs	2.9	2.9	Neg.	Neg.	Neg.	Neg.	Neg.	Neg.	Neg.	Neg.	Neg.	N/A	N/A	N/A	N/A	5.6	
<b>Other Pollutants</b>																	
H <sub>2</sub> SO <sub>4</sub> Mist	53.4	53.4	0.057	16.1	0.13	Neg.	Neg.	Neg.	Neg.	Neg.	Neg.	N/A	N/A	N/A	N/A	123.1	
PM (Residue)	76.8	76.8	4.2	16.1	0.06	1.0	Neg.	Neg.	0.073	0.037	0.036	25.8	1.5	1.9	2.5	210.8	
NH <sub>3</sub>	89.0	89.0	N/A	Neg.	Neg.	Neg.	Neg.	Neg.	Neg.	Neg.	Neg.	N/A	N/A	N/A	N/A	178.0	
CO <sub>2</sub>	2,628,262	2,628,262	Neg.	219,024	Neg.	15,459	Neg.	Neg.	Neg.	Neg.	48	128	N/A	N/A	N/A	5,491,223	
Hg (lb/yr)	26.9	26.9	Neg.	Neg.	Neg.	Neg.	Neg.	Neg.	Neg.	Neg.	Neg.	N/A	N/A	N/A	N/A	53.8	

N/A - not applicable  
Neg - negligible

<sup>1</sup> HAP emission rates when firing syngas.

Sources: ECT, 2007.  
CE, 2007.  
TEC, 2007.  
Bechtel, 2007.