



August 21, 1997

**RECEIVED**

**AUG 25 1997**

**BUREAU OF  
AIR REGULATION**

Mr. Scott Sheplak, P. E.  
Administrator, Title V Section  
Florida Department of Environmental Protection  
111 South Magnolia Dr., Suite 4  
Magnolia Park Courtyard  
Tallahassee, Florida 32301

Re: Florida Power Corporation - Bartow Plant  
File No. 1030011-002-AV

Dear Mr. Sheplak:

The Department has indicated that in order to continue processing the Title V application for the above-referenced facility, additional information will be required. Since the initial submittal of Florida Power Corporation's (FPC) Title V application for this facility, several permit amendments have been obtained from the Department's Southwest District to allow the firing of additional fuels. Specifically, permit changes were made to allow the firing of on-specification used oil in the steam units and the firing of natural gas in the combustion turbines.

FPC requests that these permit amendments be included in the Title V permit. Accordingly, all appropriate information, including fuel segment pages for natural gas and on-specification used oil are enclosed. As required, four copies of the requested information are included.

If you should have additional questions, please do not hesitate to contact me at (813) 866-5158.

Sincerely,

A handwritten signature in black ink, appearing to read "Scott H. Osbourn", is written over a horizontal line.

Scott H. Osbourn  
Senior Environmental Engineer

Enclosure

cc: Ken Kosky, Golder Associates

**Owner/Authorized Representative or Responsible Official**

1. Name and Title of Owner/Authorized Representative or Responsible Official: <b>W. Jeffrey Pardue, C.E.P., Director, Env Services Dept</b>	
2. Owner/Authorized Representative or Responsible Official Mailing Address:  Organization/Firm: <b>Florida Power Corporation</b> Street Address: <b>3201 34th Street South</b> City: <b>St. Petersburg</b> State: <b>FL</b> Zip Code: <b>33711</b>	
3. Owner/Authorized Representative or Responsible Official Telephone Numbers:  Telephone: <b>(813) 855-5151</b> Fax: <b>(813) 866-4926</b>	
4. Owner/Authorized Representative or Responsible Official Statement:  <i>I, the undersigned, am the owner or authorized representative* of the non-Title V source addressed in this Application for Air Permit or the responsible official, as defined in Rule 62-210.200, F.A.C., of the Title V source addressed in this application, whichever is applicable. I hereby certify, based on information and belief formed after reasonable inquiry, that the statements made in this application are true, accurate and complete and that, to the best of my knowledge, any estimates of emissions reported in this application are based upon reasonable techniques for calculating emissions. The air pollutant emissions units and air pollution control equipment described in this application will be operated and maintained so as to comply with all applicable standards for control of air pollutant emissions found in the statutes of the State of Florida and rules of the Department of Environmental Protection and revisions thereof. I understand that a permit, if granted by the Department, cannot be transferred without authorization from the Department, and I will promptly notify the Department upon sale or legal transfer of any permitted emissions unit.</i>	
 _____ Signature	<u>8/22/97</u> _____ Date

\* Attach letter of authorization if not currently on file.

4. Professional Engineer's Statement:

*I, the undersigned, hereby certify, except as particularly noted herein\*, that:*

*(1) To the best of my knowledge, there is reasonable assurance that the air pollutant emissions unit(s) and the air pollution control equipment described in this Application for Air Permit, when properly operated and maintained, will comply with all applicable standards for control of air pollutant emissions found in the Florida Statutes and rules of the Department of Environmental Protection; and*

*(2) To the best of my knowledge, any emission estimates reported or relied on in this application are true, accurate, and complete and are either based upon reasonable techniques available for calculating emissions or, for emission estimates of hazardous air pollutants not regulated for an emissions unit addressed in this application, based solely upon the materials, information and calculations submitted with this application.*

*If the purpose of this application is to obtain a Title V source air operation permit (check here [  ] if so), I further certify that each emissions unit described in this Application for Air Permit, when properly operated and maintained, will comply with the applicable requirements identified in this application to which the unit is subject, except those emissions units for which a compliance schedule is submitted with this application.*

*If the purpose of this application is to obtain an air construction permit for one or more proposed new or modified emissions units (check here [  ] if so), I further certify that the engineering features of each such emissions unit described in this application have been designed or examined by me or individuals under my direct supervision and found to be in conformity with sound engineering principles applicable to the control of emissions of the air pollutants characterized in this application.*

*If the purpose of this application is to obtain an initial air operation permit or operation permit revision for one or more newly constructed or modified emissions units (check here [  ] if so), I further certify that, with the exception of any changes detailed as part of this application, each such emissions unit has been constructed or modified in substantial accordance with the information given in the corresponding application for air construction permit and with all provisions contained in such permit.*

*James L. Hoff*  
\_\_\_\_\_  
Signature  
(seal) *1997*

*13 Aug 1997*  
\_\_\_\_\_  
Date

\* Attach any exception to certification statement.

## C. FACILITY POLLUTANTS

### Facility Pollutant Information

1. Pollutant Emitted	2. Pollutant Classification
SO2 Sulfur Dioxide	A
PM Particulate Matter - Total	A
PM10 Particulate Matter - PM10	A
NOx Nitrogen Oxides	A
CO Carbon Monoxide	A
VOC Volatile Organic Compounds	A
SAM Sulfuric Acid Mist	A
H133 Nickel Compounds	A
HAPS Total Hazardous Air Pollutants	A
PB Lead - Total	A

**F. SEGMENT (PROCESS/FUEL) INFORMATION  
(Regulated and Unregulated Emissions Units)**

**Segment Description and Rate:** Segment  3  of  3

1. Segment Description (Process/Fuel Type and Associated Operating Method/Mode) (limit to 500 characters):  <b>On-specification used oil</b>	
2. Source Classification Code (SCC):  <p style="text-align: center;"><b>1-01-013-02</b></p>	
3. SCC Units:  <p style="text-align: center;"><b>Thousand Gallons Burned</b></p>	
4. Maximum Hourly Rate:  <p style="text-align: center;"><b>8.841</b></p>	5. Maximum Annual Rate:  <p style="text-align: center;"><b>14,850</b></p>
6. Estimated Annual Activity Factor:	
7. Maximum Percent Sulfur:  <p style="text-align: center;"><b>2.5</b></p>	8. Maximum Percent Ash:  <p style="text-align: center;"><b>0.9</b></p>
9. Million Btu per SCC Unit:  <p style="text-align: center;"><b>138</b></p>	
10. Segment Comment (limit to 200 characters):  <b>Heat content - HHV. Max annual rate based on facility-wide limit. Monthly facility limit is 2.475 million gals.</b>	

**G. EMISSIONS UNIT POLLUTANTS  
(Regulated and Unregulated Emissions Units)**

1. Pollutant Emitted	2. Primary Control Device Code	3. Secondary Control Device Code	4. Pollutant Regulatory Code
SO2	010		EL
PM			EL
PM10			NS
NOx			NS
CO			NS
VOC			NS
H133			NS
HAPS			NS
PB			NS

**F. SEGMENT (PROCESS/FUEL) INFORMATION**  
**(Regulated and Unregulated Emissions Units)**

**Segment Description and Rate:** Segment 3 of 4

1. Segment Description (Process/Fuel Type and Associated Operating Method/Mode) (limit to 500 characters):  <b>On-specification used oil</b>	
2. Source Classification Code (SCC):  <b>1-01-013-02</b>	
3. SCC Units: <b>Thousand Gallons Burned</b>	
4. Maximum Hourly Rate:  <b>9.543</b>	5. Maximum Annual Rate:  <b>14,850</b>
6. Estimated Annual Activity Factor:	
7. Maximum Percent Sulfur:  <b>2.5</b>	8. Maximum Percent Ash:  <b>0.9</b>
9. Million Btu per SCC Unit:  <b>138</b>	
10. Segment Comment (limit to 200 characters):  <b>Heat content - HHV. Max annual rate based on facility-wide limit. Monthly facility limit is 2.475 million gals.</b>	

**G. EMISSIONS UNIT POLLUTANTS  
(Regulated and Unregulated Emissions Units)**

1. Pollutant Emitted	2. Primary Control Device Code	3. Secondary Control Device Code	4. Pollutant Regulatory Code
SO2			EL
PM			EL
PM10			NS
NOx			NS
CO			NS
VOC			NS
H133			NS
HAPS			NS
PB			NS



Segment Description and Rate: Segment 4 of 5

1. Segment Description (Process/Fuel Type and Associated Operating Method/Mode) (limit to 500 characters): <b>On-specification used oil</b>	
2. Source Classification Code (SCC): <b>1-01-013-02</b>	
3. SCC Units: <b>Thousand Gallons Burned</b>	
4. Maximum Hourly Rate: <b>16.022</b>	5. Maximum Annual Rate: <b>14,850</b>
6. Estimated Annual Activity Factor:	
7. Maximum Percent Sulfur: <b>2.5</b>	8. Maximum Percent Ash: <b>0.9</b>
9. Million Btu per SCC Unit: <b>138</b>	
10. Segment Comment (limit to 200 characters): <b>Heat content - HHV. Max annual rate based on facility-wide limit. Monthly facility limit is 2.475 million gals.</b>	

**G. EMISSIONS UNIT POLLUTANTS  
(Regulated and Unregulated Emissions Units)**

1. Pollutant Emitted	2. Primary Control Device Code	3. Secondary Control Device Code	4. Pollutant Regulatory Code
SO2			EL
PM			EL
PM10			NS
NOx			NS
CO			NS
VOC			NS
H133			NS
HAPS			NS
PB			NS

**C. EMISSIONS UNIT DETAIL INFORMATION**  
(Regulated Emissions Units Only)

**Emissions Unit Details**

1. Initial Startup Date:	14 Jun 1972	
2. Long-term Reserve Shutdown Date:		
3. Package Unit:		
Manufacturer:	General Electric	Model Number: MS 7000
4. Generator Nameplate Rating:	56 MW	
5. Incinerator Information:		
	Dwell Temperature:	°F
	Dwell Time:	seconds
	Incinerator Afterburner Temperature:	°F

**Emissions Unit Operating Capacity**

1. Maximum Heat Input Rate:	714	mmBtu/hr
2. Maximum Incineration Rate:	lbs/hr	tons/day
3. Maximum Process or Throughput Rate:		
4. Maximum Production Rate:		
5. Operating Capacity Comment (limit to 200 characters):		
	Maximum heat input based on permit limit firing No. 2 fuel oil and natural gas. Max heat input rate function of ambient temperature.	

**Emissions Unit Operating Schedule**

1. Requested Maximum Operating Schedule:		
	24 hours/day	7 days/week
	52 weeks/yr	8,760 hours/yr

**Segment Description and Rate:** Segment 2 of 2

1. Segment Description (Process/Fuel Type and Associated Operating Method/Mode) (limit to 500 characters): <b>Natural gas</b>	
2. Source Classification Code (SCC): <b>2-01-002-01</b>	
3. SCC Units: <b>Million Cubic Feet</b>	
4. Maximum Hourly Rate: <b>0.714</b>	5. Maximum Annual Rate: <b>6,255</b>
6. Estimated Annual Activity Factor:	
7. Maximum Percent Sulfur:	8. Maximum Percent Ash:
9. Million Btu per SCC Unit: <b>1,000</b>	
10. Segment Comment (limit to 200 characters): <b>Heat Content - LHV.</b>	

**Additional Supplemental Requirements for Category I Applications Only**

10. Alternative Methods of Operation <input checked="" type="checkbox"/> Attached, Document ID: <u>BA-EU5-L10</u> <input type="checkbox"/> Not Applicable
11. Alternative Modes of Operation (Emissions Trading) <input type="checkbox"/> Attached, Document ID: _____ <input checked="" type="checkbox"/> Not Applicable
12. Identification of Additional Applicable Requirements <input checked="" type="checkbox"/> Attached, Document ID: <u>BA-EU5-L12</u> <input type="checkbox"/> Not Applicable
13. Compliance Assurance Monitoring Plan <input checked="" type="checkbox"/> Attached, Document ID: <u>BA-EU5-L13</u> <input type="checkbox"/> Not Applicable
14. Acid Rain Permit Application (Hard Copy Required) <input type="checkbox"/> Acid Rain Part - Phase II (Form No. 62-210.900(1)(a)) Attached, Document ID: _____ <input type="checkbox"/> Repowering Extension Plan (Form No. 62-210.900(1)(a)1.) Attached, Document ID: _____ <input type="checkbox"/> New Unit Exemption (Form No. 62-210.900(1)(a)2.) Attached, Document ID: _____ <input type="checkbox"/> Retired Unit Exemption (Form No. 62-210.900(1)(a)3.) Attached, Document ID: _____ <input checked="" type="checkbox"/> Not Applicable

**ATTACHMENT BA-EU5-L1**

**PROCESS FLOW DIAGRAM**

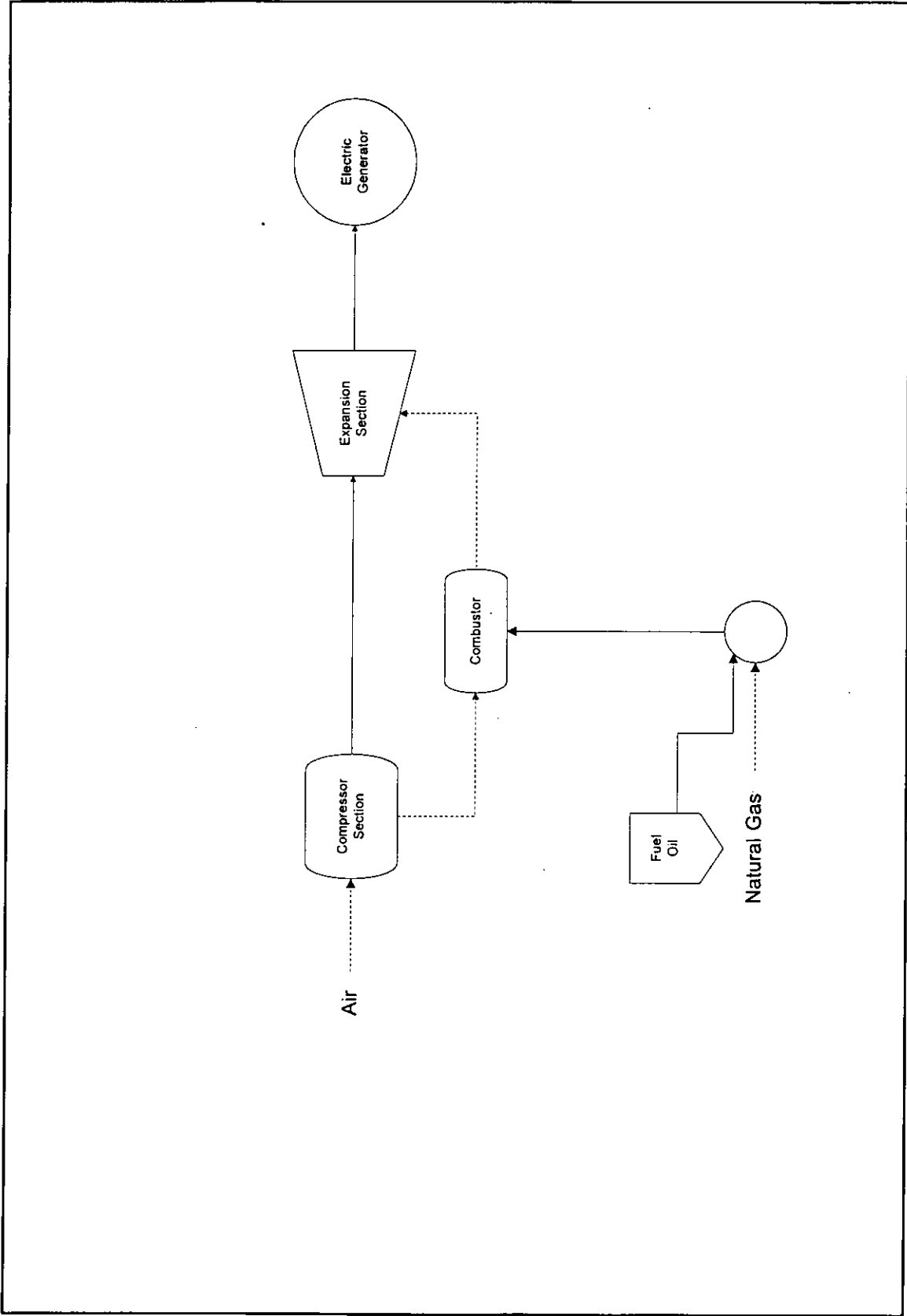

Florida Power Corporation, Bartow Plant Process Flow Diagram	<b>Process Flow Legend:</b> Solid / Liquid Gas		<b>Emission Unit:</b> Peaking Gas Turbines No. 1, 2, 3, 4 <b>Filename:</b> FPCBA.VSD <b>Latest Revision Date:</b> 8/18/97	

## ATTACHMENT BA-EU5-L2

### FUEL ANALYSIS

#### Natural Gas Analysis

<u>Parameter</u>	<u>Typical Value</u>	<u>Max Value</u>
Relative density	0.58 (compared to air)	
heat content	950 - 1124 Btu/cu ft.	
% sulfur	0.43 grains/CCF <sup>1</sup>	1 grain/100 CF
% nitrogen	0.8% by volume	
% ash	negligible	

Note: The values listed are "typical" values based upon information supplied to FPC by Florida Gas Transmission (FGT). However, analytical results from grab samples of fuel taken at any given point in time may vary from those listed.

<sup>1</sup> Data from laboratory analysis



**ATTACHMENT BA-EU5-L10**  
**ALTERNATIVE METHODS OF OPERATION**

## ATTACHMENT BA-EU5-L10

### ALTERNATIVE METHODS OF OPERATION

The combustion turbines can be fired with either natural gas or No. 2 fuel oil with a maximum sulfur content of 0.5% by weight. Maximum heat input rate is 714 MMBtu/hr (LHV) for each turbine.

**ATTACHMENT BA-EU5-L12**

**IDENTIFICATION OF ADDITIONAL APPLICABLE REQUIREMENTS**



File: 420001, 4, 1711 permits  
**Department of  
Environmental Protection**

JMK  
**RECEIVED**

**FEB 21 1997**

Environmental Svcs  
Department

Lawton Chiles  
Governor

Southwest District  
3804 Coconut Palm Drive  
Tampa, Florida 33619

Virginia B. Wetherell  
Secretary

**NOTICE OF PERMIT AMENDMENTS**

Mr. W. Jeffrey Pardue, C.E.P.  
Director of Environmental Services  
Florida Power Corporation  
Post Office Box 14042  
St. Petersburg, FL 33733

Dear Mr. Pardue:

Re: Air Pollution Operation Permit Amendment Requests, Dated  
November 3, 1995 and August 29, 1996 to Allow the Burning of  
On-Specification Used Oil in Bartow Unit Nos. 1, 2, and 3  
Reference Permit Nos.: Unit No. 1 - AO52-233149  
Unit No. 2 - AO52-216412  
Unit No. 3 - AO52-216413 and amendment  
dated August 16, 1995

ARMS Processing No.: 1030011-001-AO

On November 7, 1995 and September 3, 1996, the Department received the above referenced requests from Florida Power Corporation. The following amendments allow the burning of on-specification used oil at a level corresponding to five percent of the total allowable annual heat input to Unit Nos. 1, 2, and 3 (i.e., up to 14.85 million gallons per year for a facility-wide total) and up to ten percent in any one month (i.e., up to 2.475 million gallons per month for a facility-wide total).

**UNIT NO. 1, PERMIT NO. AO52-233149**

*Change Description (page 1) From:*

For the operation of Bartow Plant Fossil Fuel Steam Generator Unit No. 1 rated at 120 MW/hour with a maximum heat input of 1,220 MMBTU/hour. This unit is fired with new No. 6 fuel oil having a maximum sulfur content not to exceed 2.5% by weight. The maximum fuel usage is 187.0 BBL/hour. Emissions are controlled by a General Electric Environmental Services, Inc., Model 1-BAB1.2x37(9)36.0-434-4.3P, Electrostatic Precipitator consisting of five fields in depth. A Contraves Goertz Model 701 Continuous Emissions Monitor (CEM) for opacity with a recorder is used for continual observation of stack opacity.

*Change Description (page 1) To:*

For the operation of Bartow Plant Fossil Fuel Steam Generator Unit No. 1 rated at 120 MW/hour with a maximum heat input of 1,220 MMBTU/hour. This unit is fired with new No. 6 fuel oil having a maximum sulfur content not to exceed 2.5% by weight. The maximum fuel usage for Unit No. 1 is 187.0 BBL/hour, 7,854 gallons/hour. On-specification used oil is also allowed to be fired, as specified below. The amount of on-specification used oil burned shall not exceed a level corresponding to five percent of the total allowable annual heat input to Unit Nos. 1, 2, and 3 (i.e., up to 14.85 million gallons per year) and up to ten percent in any one month (i.e., up to 2.475 million gallons per month for a facility-wide total). Emissions are controlled by a General Electric Environmental Services, Inc., Model 1-BAB1.2x37(9)36.0-434-4.3P, Electrostatic Precipitator consisting of five fields in depth. A Durag Model 281 Continuous Emissions Monitor (CEM) for opacity with a recorder is used for continual observation of stack opacity..

*Change Specific Condition 4 From:*

4. This boiler shall be fired with new No. 6 fuel oil at a maximum heat input rate not to exceed 1,220 MMBTU/hour, 7,854 gallons/hour. [Previous permits and information supplied with application]

*Change Specific Condition 4 To:*

4.(a) This boiler shall be fired with new No. 6 fuel oil and/or on-specification used oil at a maximum heat input rate not to exceed 1,220 MMBTU/hour, 7,854 gallons/hour . [Previous permits and requests dated 11/3/95 & 8/29/96]

(b) The burning of on-specification used oil in Unit Nos. 1, 2, and 3 shall not exceed a total of 14.85 million gallons per consecutive 12-month period and 2.475 million gallons per month and is subject to the following restrictions:

(1) In order to be considered on-specification used oil, the oil shall meet the following specifications:

1. Arsenic shall not exceed 5 ppm.
2. Cadmium shall not exceed 2 ppm.
3. Chromium shall not exceed 10 ppm.
4. Lead shall not exceed 100 ppm.
5. Total halogens shall not exceed 1,000 ppm.
6. Flash point shall not be less than 100 degrees F

[40 CFR 279.11 & Rule 62-710.210, F.A.C.]

- (2) Used oil containing a PCB concentration of 50 or more ppm shall not be burned in this source. Used oil shall not be blended to meet this requirement.  
[40 CFR 279.11 & 40 CFR 761.20]
- (3) On-specification used oil with a PCB concentration of 2 to 49 ppm shall be burned only at normal source operating temperatures (i.e., at 50% of full load or greater); used oil with a PCB concentration of less than 2 ppm may be at any time  
[40 CFR 761.20(e)(3) & Rule 62-4.070(3), F.A.C.]
- (4) Before accepting from each marketer the first shipment of on-specification used oil with a PCB concentration of 2 to 49 ppm, the permittee shall provide each marketer with a one-time written and signed notice certifying that the permittee will burn the used oil in a qualified combustion device. The notice must state that EPA or a RCRA-delegated state agency has been given a description of the used oil management activities at the facility and that an industrial boiler or furnace will be used to burn the used oil with a PCB concentration of 2 to 49 ppm. The description of the used oil management activities may be submitted to the Administrator, Hazardous Waste Regulation Section, Florida Department of Environmental Protection, 2600 Blair Stone Road, Tallahassee, FL 32399-2400.  
[40 CFR 279.61 & 40 CFR 761.20(e)(3)(ii)]
- (5) Each shipment or on-site generated batch of used oil to be burned shall be sampled and analyzed for sulfur, arsenic, cadmium, chromium, lead, total halogens, flash point, and PCBs\* using EPA or ASTM approved methods.

\*A claim that used oil does not contain quantifiable levels of PCBs (that is, that the used oil contains less than 2 ppm of PCBs) must be documented by analysis or other information. The first person making the claim that the used oil does not contain PCBs is responsible for furnishing the documentation. The documentation can be tests, personal or special knowledge of the source and composition of the used oil, or a certification from the person generating the used oil claiming that the used oil contains no detectable PCBs.  
[40 CFR 761(e)(2) & Rule 62-4.070(3), F.A.C.]

*Change Specific Condition 5 From:*

5. Sulfur content of the new No. 6 fuel oil fired in this boiler shall not exceed 2.5% sulfur by weight. In no case shall sulfur dioxide emissions from this boiler exceed 2.75 pounds/MMBTU of heat input nor 3,355 lbs per hour at maximum heat input rate.  
[Previous permits and Rule 17-296.405(1)(c)1.k., F.A.C.]

*Change Specific Condition 5 To:*

5. The sulfur content of the new No. 6 fuel oil fired in this boiler shall not exceed 2.5% sulfur by weight. The sulfur content of the on-specification used oil fired in this boiler shall not exceed 2.5% sulfur by weight. In no case shall sulfur dioxide emissions from this boiler exceed 2.75 pounds/MMBTU of heat input nor 3,355 lbs per hour at maximum heat input rate.  
[Previous permits and Rules 62-296.405(1)(c)1.k. & 62-4.070(3), F.A.C.]

*Change Specific Condition 14 From:*

14. Approved compliance testing of emissions must be conducted while firing new No. 6 fuel oil...

*Change Specific Condition 14 To:*

14. Approved compliance testing of emissions must be conducted while firing new No. 6 fuel oil or new No. 6 fuel oil/on-specification used oil ...

*Change Specific Condition 15 From:*

15. The following are the specified permitted process parameters for this Unit [Rule 17-296.700(6)(d), F.A.C.]:

A. Process Parameters

- |                      |  |
|----------------------|--|
| 1. Heat Input Rate:  | 1,220 MMBTU/hour (maximum)                               |
| 2. Fuel:             | No. 6 fuel oil with a sulfur content of 2.5% (maximum)   |
| 3. Fuel Firing Rate: | 7,854 gallons/hour (187 BBL/hour) of No. 6 oil (maximum) |
| 4....                |  |

*Change Specific Condition 15 To:*

15. The following are the specified permitted process parameters for this Unit [Rule 62-296.700(6)(d), F.A.C.]:

A. Process Parameters

1. Heat Input Rate: 1,220 MMBTU/hour (maximum)
2. Fuel: New No. 6 fuel oil with a sulfur content of 2.5%, by weight (maximum) and on-specification used oil with a sulfur content of 2.5%, by weight (maximum).
3. Fuel Firing Rate: 7,854 gallons/hour (187 BBL/hour) of new No. 6 fuel oil and/or on-specification used oil (maximum)
- 4....

*Add Specific Condition Nos. 22 and 23:*

22. In order to document continuing compliance with Specific Condition No. 4(b) for Unit Nos. 1, 2, and 3, the permittee shall maintain the following records:

- (a) The quantity of used oil accepted, the date of acceptance, and the receiving tank ID No.
- (b) The name, address, and EPA identification number (if applicable) of all transporters and generators or processors/re-refiners of the used oil delivered to the facility.
- (c) A copy of the notice to EPA or a RCRA-delegated state agency and a copy of the one-time written notice provided to each marketer.
- (d) Results of the analyses required in Specific Condition No. 4(b)(5).
- (e) Documentation that the used oil contains less than 2 ppm PCBs, if claimed, including the name and address of the person making the claim.
- (f) The date, time, Unit No., and a statement of the status of the unit (startup, normal operating, or shutdown) when burning used oil containing 2 to 49 ppm PCBs. Records of % of full load shall be made available, if requested.
- (g) The monthly total of used oil burned at the facility (based on monthly receipts).



- (h) The total used oil burned at the facility for the most recent consecutive 12-month period.

These records shall be recorded in a permanent form suitable for inspection by the Department upon request, and shall be retained for at least a 5 year period. [40 CFR 60.279.65 & 66, 40 CFR 761.20(30(4) & Rule 62-4.070(3), F.A.C.]

23. The permittee shall submit with the annual operation report the total amount of on-specification used oil received and burned in the prior calendar year.

[Rule 62-4.070(3), F.A.C.]

UNIT NO. 2, PERMIT NO. A052-216412

*Change Description (page 1) From:*

For the operation of Bartow Unit No. 2, a fossil fuel fired electric utility steam generator rated at 120 MW/hour. The unit is fired with No. 6 fuel oil, with a maximum sulfur content of 2.5% by weight, at a maximum heat input rate of 1,317 MMBtu/hour (209 BBL/hour, 8,778 gallons/hour).

*Change Description (page 1) To:*

For the operation of Bartow Unit No. 2, a fossil fuel fired electric utility steam generator rated at 120 MW/hour. The unit is fired with new No. 6 fuel oil, with a maximum sulfur content of 2.5% by weight, at a maximum heat input rate of 1,317 MMBtu/hour (209 BBL/hour, 8,778 gallons/hour). On-specification used oil is also allowed to be fired. The on-specification used oil burned in Unit No. 2 shall comply with usage, content, operating, and recordkeeping requirements contained in the above amendments to Unit No. 1. The burning of on-specification used oil in Unit Nos. 1, 2, and 3 shall not exceed a total of 14.85 million gallons per consecutive 12-month period and 2.475 million gallons per month.

*Change Specific Condition 4 From:*

4. This boiler shall be fired with No. 6 fuel oil at a maximum heat input rate not to exceed 1,317 MMBtu/hour (8,778 gallons/hour).  
[Previous permits and information supplied with application].

*Change Specific Condition 4 To:*

4.(a) This boiler shall be fired with new No. 6 fuel oil and/or on-specification used oil at a maximum heat input rate not to exceed 1,317 MMBtu/hour (8,778 gallons/hour).  
[Previous permits and requests dated 11/3/95 & 8/29/96]

(b) The burning of on-specification used oil in Unit Nos. 1, 2, and 3 shall not exceed a total of 14.85 million gallons per consecutive 12-month period and 2.475 million gallons per month and shall comply with Specific Condition No. 4(b) from the above amendments to Unit No. 1.

*Change Specific Condition 5 From:*

5. Sulfur content of the No. 6 fuel oil fired in this boiler shall not exceed 2.5% sulfur by weight. In no case shall sulfur dioxide emissions from this boiler exceed 2.75 pounds/MMBtu of heat input nor 3,662 lbs per hour at maximum heat input rate.  
[Previous permits and Rule 17-296.405(1)(c)1.k, F.A.C.]

*Change Specific Condition 5 To:*

5. The sulfur content of the new No. 6 fuel oil fired in this boiler shall not exceed 2.5% sulfur by weight. The sulfur content of the on-specification used oil fired in this boiler shall not exceed 2.5% sulfur by weight. In no case shall sulfur dioxide emissions from this boiler exceed 2.75 pounds/MMBTU of heat input nor 3,662 lbs per hour at maximum heat input rate.  
[Previous permits and Rules 62-296.405(1)(c)1.k. & 62-4.070(3), F.A.C.]

*Change Specific Condition 14 From:*

14. Approved compliance testing of emissions must be conducted while firing No. 6 fuel oil...

*Change Specific Condition 14 To:*

14. Approved compliance testing of emissions must be conducted while firing new No. 6 fuel oil or new No. 6 fuel oil/on-specification used oil ...

*Change Specific Condition 15 From:*

15. The following is the specified Operation and Maintenance Plan for Particulate Control as required by Rule 17-296.700(6), F.A.C. (Particulate Matter RACT).

A. Process Parameters (Rule 17-296.700(6)(d), F.A.C.)

1. Heat Input Rate: 1,317 MMBtu/hour (maximum)
2. Fuel: No. 6 fuel oil with a max. sulfur content of 2.5%
3. Fuel Firing Rate: 8,778 gallons/hour (209 BBL/hour) of No. 6 oil (maximum)
- 4....

*Change Specific Condition 15 To:*

15. The following is the specified Operation and Maintenance Plan for Particulate Control as required by Rule 62-296.700(6), F.A.C. (Particulate Matter RACT).

A. Process Parameters

1. Heat Input Rate: 1,317 MMBtu/hour (maximum)
2. Fuel: New No. 6 fuel oil with a sulfur content of 2.5%, by weight (maximum) and on-specification used oil with a sulfur content of 2..5%, by weight (maximum)
3. Fuel Firing Rate: 8,778 gallons/hour (209 BBL/hour) of new No. 6 fuel oil and/or on-specification used oil (maximum)
- 4....

UNIT NO. 3, PERMIT NO. A052-216413

&

UNIT NO. 3, AMENDMENTS DATED AUGUST 16, 1995

*Change Description From:*

For the operation of Bartow Unit No. 3, a fossil fired electric utility steam generator rated at 225 MW/hour. The unit is fired with No. 6 fuel oil, with a maximum sulfur content of 2.5%, by weight, at a maximum heat input rate of 2,211 MMBtu/hour or natural gas at a maximum heat rate input of 2,266 MMBtu/hour.

*Change Description (page 1) To:*

For the operation of Bartow Unit No. 3, a fossil fired electric utility steam generator rated at 225 MW/hour. The unit is fired with new No. 6 fuel oil (maximum sulfur content of 2.5%, by weight) and/or on-specification used oil (maximum sulfur content of 2.5%, by weight) at a maximum heat input rate of 2,211 MMBtu/hour. Natural gas is also allowed to be fired at a maximum heat rate input of 2,266 MMBtu/hour. The on-specification used oil burned in Unit No. 3 shall comply with usage, content, operating, and recordkeeping requirements contained in the above amendments to Unit No. 1. The burning of on-specification used oil in Unit Nos. 1, 2, and 3 shall not exceed a total of 14.85 million gallons per consecutive 12-month period and 2.475 million gallons per month.

*Change Specific Condition 4 From:*

4. This boiler is permitted to fire No. 6 fuel oil and/or natural gas. The maximum heat input rate to this boiler shall not exceed the following:

- A. 2,211 MMBtu/hr when firing No. 6 fuel oil alone;
- B. 2,266 MMBtu/hr when firing natural gas alone;
- C. 2,266 MMBtu/hour when firing No. 6 fuel oil and natural gas together, with a maximum of 2,211 MMBtu/hour coming from No. 6 fuel oil.

[Previous permits and renewal information]

*Change Specific Condition 4 To:*

4. (a) This boiler is permitted to fire new No. 6 fuel oil, on-specification used oil, and natural gas. The maximum heat input rate to this boiler shall not exceed the following:

1. 2,211 MMBtu/hr when firing new No. 6 fuel oil and/or on-specification used oil;
2. 2,266 MMBtu/hr when firing natural gas alone;
3. 2,266 MMBtu/hour when firing new No. 6 fuel oil and/or on-specification used oil and natural gas together, with a maximum of 2,211 MMBtu/hour coming from new No. 6 fuel oil and/or on-specification used oil.

(b) The burning of on-specification used oil in Unit Nos. 1, 2, and 3 shall not exceed a total of 14.85 million gallons per consecutive 12-month period and 2.475 million gallons per month and shall comply with Specific Condition No. 4(b) from the above amendments to Unit No. 1. [Previous permits and requests dated 11/3/95 and 8/29/96]

*Change Specific Condition 5 From:*

5. Sulfur content of the No. 6 fuel oil fired in this boiler shall not exceed 2.5% sulfur by weight. In no case shall sulfur dioxide emissions from this boiler exceed 2.75 pounds/MMBtu of heat input nor 6,080 pounds per hour at maximum heat input rate. [Previous permits and Rule 17-296.40591)(c)1.k, F.A.C.]

*Change Specific Condition 5 To:*

5. The sulfur content of the new No. 6 fuel oil fired in this boiler shall not exceed 2.5% sulfur by weight. The sulfur content of the on-specification used oil fired in this boiler shall not exceed 2.5% sulfur by weight. In no case shall sulfur dioxide emissions from this boiler exceed 2.75 pounds/MMBTU of heat input nor 6,080 pounds per hour at maximum heat input rate. [Previous permits and Rules 62-296.405(1)(c)1.k. & 62-4.070(3), F.A.C.]

*Change Specific Condition 14 From:*

14. Approved compliance testing of emissions must be conducted while firing No. 6 fuel oil...

*Change Specific Condition 14 To:*

14. Approved compliance testing of emissions must be conducted while firing new No. 6 fuel oil or new No. 6 fuel oil/on-specification used oil ...

*Change Specific Condition 15 From:*

15. The following is the specified Operation and Maintenance Plan for Particulate Control as required by Rule 17-296.700(6), F.A.C. (Particulate Matter RACT).

A. Process Parameters (Rule 17-296.700(6)(d), F.A.C.)

1. Heat Input Rate: 2,266 MMBtu/hour (maximum)
2. Fuel: No. 6 fuel oil with a max. sulfur content of 2.5% (also natural gas when available)
3. Fuel Firing Rate: 14,742 gallons/hour (351 BBL/hour) of No. 6 oil (maximum), 2.2 MMCF/hour of natural gas (max.)
- 4....

*Change Specific Condition 15 To:*

15. The following is the specified Operation and Maintenance Plan for Particulate Control as required by Rule 62-296.700(6), F.A.C.. (Particulate Matter RACT).

A. Process Parameters

1. Heat Input Rate: 2,266 MMBtu/hour (maximum)
2. Fuel: New No. 6 fuel oil with a sulfur content of 2.5%, by weight (maximum) and/or on-specification used oil with a sulfur content of 2.5%, by weight (maximum) (also natural gas when available)
3. Fuel Firing Rate: 14,742 gallons/hour (351 BBL/hour) of No. 6 oil and/or on-specification used oil (maximum), 2.2 MMCF/hour of natural gas (max.)

Any party to this Order (permit amendments) has the right to seek judicial review of the permit pursuant to Section 120.68, Florida Statutes, by the filing of a Notice of Appeal pursuant to Rule 9.110, Florida Rules of Appellate Procedure, with the Clerk of the Department in the Office of General Counsel, Douglas Building, Mail Station 35, 3900 Commonwealth Blvd., Tallahassee, Florida 32399-3000; and by filing a copy of the Notice of Appeal accompanied by the applicable filing fees with the appropriate District Court of Appeal. The Notice of Appeal must be filed within 30 days from the date this Notice is filed with the Clerk of the Department.

Executed in Tampa, Florida.

STATE OF FLORIDA DEPARTMENT  
OF ENVIRONMENTAL PROTECTION

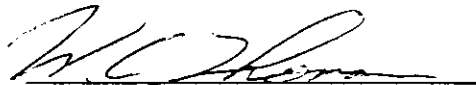

W.C. Thomas, P.E.  
District Air Administrator  
Southwest District

cc:

Mr. Gary Robbins, PCDEM  
Mr. Ed Svec, DARM

CERTIFICATE OF SERVICE

The undersigned duly designated deputy clerk hereby certifies that this NOTICE OF PERMIT AMENDMENTS and all copies were mailed by certified mail before the close of business on 2/19/97 to the listed persons.

FILING AND ACKNOWLEDGEMENT FILED, on this date, pursuant to Section 120.52(11), Florida Statutes, with the designated Department Clerk, receipt of which is hereby acknowledged.

Carol S. Moore 2/19/97  
Clerk /Date



File: Bartow CT/Air Permit

# Department of Environmental Protection

Lawton Chiles  
Governor

Southwest District  
3804 Coconut Palm Drive  
Tampa, Florida 33619

Virginia B. Wetherell  
Secretary

## NOTICE OF PERMIT AMENDMENT

### CERTIFIED MAIL

Mr. Scott Osbourn  
Senior Environmental Engineer  
Florida Power Corporation  
P.O. Box 14042  
St. Petersburg, Florida 33733

Dear Mr. Osbourn:

Re: Bartow Combustion Turbine Peaking Units 1 - 4  
Operation Permit Amendments -  
Addition of Natural Gas as a Permitted Fuel  
Permit Numbers: AO52-253215A (Peaking Unit No. 1)  
AO52-253216A (Peaking Unit No. 2)  
AO52-253217A (Peaking Unit No. 3)  
AO52-253218A (Peaking Unit No. 4)  
(Processed under ARMS PA Project 1030011-003-AO)

On November 18, 1996, the Department received your request to amend the above permits. The requested amendments consist of the addition of natural gas as a permitted fuel for each of the four combustion turbine peaking units. Review of the Department permit files for these emission units shows that the only construction permit for these units, AC-369, was issued on June 24, 1971, well prior to the date that would make any of its provisions federally enforceable. Therefore, since there are no federally enforceable permit requirements limiting the fuel used in these peaking units to No. 2 fuel oil only, and since the use of natural gas will not result in an increase in emission rates of any regulated pollutant, this change is not considered a modification as defined in Rule 62-210.300, F.A.C. As a result, the requested change can be accomplished by an operation permit amendment. Establishing of all of the permit requirements as federally enforceable will be accomplished at a later date through issuance of a Title V major source operation permit for this facility.

Therefore, permit numbers AO52-253215A, AO52-253216A, AO52-253217A, and AO52-253218A are hereby amended as follows:

"Protect, Conserve and Manage Florida's Environment and Natural Resources"

Printed on recycled paper.



Page 1 of 8 DescriptionFrom:

For the operation of an oil fired, gas turbine driven electrical generating unit with a rated maximum capacity of 55.7 MW. The unit is designated as the Bartow Peaking Unit No. *(insert appropriate unit number)* and is composed of a General Electric Company, Serial No. *((insert appropriate unit number)* electric generator driven by a General Electric Company, Model MS 7000, Serial No. *(insert appropriate unit number)* gas turbine. The manufacturer's fuel flow and heat input ratings for the turbine are 121 barrels per hour or 714 MMBtu per hour, respectively. The peak heat input rate of the turbine is a function of the ambient temperature as shown on the graph of *Fuel Heat Input versus Ambient Temperature* included in this permit. The turbine utilizes new, No. 2 fuel oil with a maximum sulfur content of 0.5%, by weight.

To:

For the operation of an oil/natural gas fired gas turbine driven electrical generating unit with a rated maximum capacity of 55.7 MW. The unit is designated as the Bartow Peaking Unit No. *(insert appropriate unit number)* and is composed of a General Electric Company, Serial No. *((insert appropriate unit number)* electric generator driven by a General Electric Company, Model MS 7000, Serial No. *(insert appropriate unit number)* gas turbine. The manufacturer's fuel flow and heat input ratings for the turbine are 5,174 gallons per hour of No. 2 fuel oil, or 714 MCF per hour of natural gas (corresponds to approximately 714 MMBtu per hour). The peak heat input rate of the turbine is a function of the ambient temperature as shown on the graph of *Fuel Heat Input versus Ambient Temperature* included in this permit. The turbine utilizes new No. 2 fuel oil with a maximum sulfur content of 0.5% (by weight), and/or natural gas.

- - - - -

Page 2 of 8      Specific Condition No. 6.From:

6. The Bartow Peaking Unit No. *(insert appropriate unit number)* shall only utilize new, No. 2 fuel oil with a maximum sulfur content of 0.5%, by weight. "New, No. 2 fuel oil" is defined as fuel oil that has been refined from crude oil and has not been used and which may or may not contain additives.

To:

6. The Bartow Peaking Unit No. *(insert appropriate unit number)* shall only utilize new No. 2 fuel oil with a maximum sulfur content of 0.5%, by weight, or natural gas. "New, No. 2 fuel oil" is defined as fuel oil that has been refined from crude oil and has not been used and which may or may not contain additives.

Page 3 of 8      Specific Condition No. 9.

From:

9. Testing of visible emissions should be conducted with the turbines operating within 90-100% of the peak heat input rate based on the average ambient air temperature during the test. The .....  
.....(remainder of condition unaffected).

To:

9. Testing of visible emissions should be conducted while firing No. 2 fuel oil with the turbines operating within 90-100% of the peak heat input rate based on the average ambient air temperature during the test. The .....(remainder of condition unaffected).

-----

A person whose substantial interests are affected by this permit amendment may petition for an administrative proceeding (hearing) in accordance with Section 120.57, Florida Statutes. The petition must contain the information set forth below and must be filed (received) in the Office of General Counsel of the Department at 3900 Commonwealth Boulevard, Tallahassee, Florida 32399-3000, within 14 days of receipt of this permit. Petitioner shall mail a copy of the petition to the applicant at the address indicated above at the time of filing. Failure to file a petition within this time period shall constitute a waiver of any right such person may have to request an administrative determination (hearing) under section 120.57 Florida Statutes.

The Petition shall contain the following information;

- (a) The name, address, and the telephone number of each petitioner, the applicant's name and address, the Department Permit File Number and the county in which the project is proposed;
- (b) A statement of how and when each petitioner received notice of the Department's action or proposed action;
- (c) A statement of how each petitioner's substantial interests are affected by the Department's action or proposed action;
- (d) A statement of the material facts disputed by petitioner;
- (e) A statement of facts which petitioner contends warrants reversal or modification of the Department's action;
- (f) A statement of which rules or statutes petitioner contends require reversal or modification of the Department's action or proposed action; and
- (g) A statement of the relief sought by petitioner, stating precisely the action petitioner wants the Department to take with respect to the Department's action or proposed action.

If a petition is filed, the administrative hearing process is designed to formulate agency action. Accordingly, the Department's final action may be different from the position taken by it in this permit amendment. Persons whose substantial interests will be affected by any decision of the Department with regard to the application have the right to petition to become a party to the proceeding. The petition must conform to the requirements specified above and be filed (received) within 14 days of receipt of this notice, in the Office of General Counsel at the above address of the Department. Failure to petition within the allotted time frame constitutes a waiver of any rights such person has to request a hearing under Section 120.57, F.S., and to participate as a party to this proceeding. Any subsequent intervention will only be at the approval of the presiding officer upon motion filed pursuant to Rule 28-5.207, F.A.C.

This permit amendment is final and effective on the date filed with the Clerk of the Department unless a petition is filed in accordance with the above paragraphs or unless a request for extension of time in which to file a petition is filed within the time specified for filing a petition and conforms to Rule 62-103.070, F.A.C. Upon timely filing of a petition or a request for an extension of time this permit amendment will not be effective until further Order of the Department.

When the Order (Permit Amendment) is final, any party to the Order has the right to seek judicial review of the Order pursuant to Section 120.68, Florida Statutes, by the filing of a Notice of Appeal pursuant to Rule 9.110, Florida Rules of Appellate Procedure, with the Clerk of the Department in the Office of General Counsel, 2600 Blair Street Road, Tallahassee, Florida 32399-2400; and by filing a copy of the Notice of Appeal accompanied by the applicable filing fees with the appropriate District Court of Appeal. The Notice of Appeal must be filed within 30 days from the date the Final Order is filed with the Clerk of the Department.

This letter must be attached to and becomes a part of permits AO52-253215A, AO52-253216A, AO52-253217A, and AO52-253218A. If you have any questions please call Mr. David Zell of my staff at (813) 744-6100, extension 118.

Sincerely,

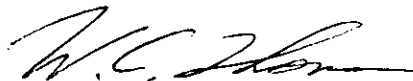

W.C. Thomas, P.E.  
Director Air Program Administrator  
Southwest District

DRZ/

copies to:

Gary Robbins, Pinellas County Dept. of Environmental Management  
Charles Logan, FDEP BAR Tallahassee, Tile V Permit Section

CERTIFICATE OF SERVICE

This is to certify that this NOTICE OF PERMIT AMENDMENT and all copies were mailed by certified mail before the close of business on JAN 13 1997 to the listed persons.

FILING AND ACKNOWLEDGEMENT FILED,  
on this date, pursuant to Section  
120.52(7), Florida Statutes, with  
the designated Department Clerk,  
receipt of which is hereby  
acknowledged.

Carol S. Moore      1/13/97  
Clerk                              Date