

Department of Environmental Protection

RECEIVED

MAR 17 2008

Division of Air Resource Management

BUREAU OF AIR REGULATION

APPLICATION FOR AIR PERMIT - LONG FORM

I. APPLICATION INFORMATION

Air Construction Permit - Use this form to apply for any air construction permit at a facility operating under a federally enforceable state air operation permit (FESOP) or Title V air permit. Also use this form to apply for an air construction permit:

- For a proposed project subject to prevention of significant deterioration (PSD) review, nonattainment area (NAA) new source review, or maximum achievable control technology (MACT) review; or
Where the applicant proposes to assume a restriction on the potential emissions of one or more pollutants to escape a federal program requirement such as PSD review, NAA new source review, Title V, or MACT; or
Where the applicant proposes to establish, revise, or renew a plantwide applicability limit (PAL).

Air Operation Permit - Use this form to apply for:

- An initial federally enforceable state air operation permit (FESOP); or
An initial/revised/renewal Title V air operation permit.

Air Construction Permit & Title V Air Operation Permit (Concurrent Processing Option) - Use this form to apply for both an air construction permit and a revised or renewal Title V air operation permit incorporating the proposed project.

To ensure accuracy, please see form instructions.

Identification of Facility

1. Facility Owner/Company Name: Orlando Utilities Commission
2. Site Name: Stanton Energy Center
3. Facility Identification Number: 0950137
4. Facility Location... Street Address or Other Locator: 5100 South Alafaya Trail
City: Orlando County: Orange Zip: Code: 32831
5. Relocatable Facility? [] Yes [x] No
6. Existing Title V Permitted Facility? [x] Yes [] No

Application Contact

1. Application Contact Name: Denise Stalls, Vice President Environmental Affairs
2. Application Contact Mailing Address... Organization/Firm: Orlando Utilities Commission
Street Address: P.O. Box 3193
City: Orlando State: FL Zip Code: 32802
3. Application Contact Telephone Numbers... Telephone: (407) 737-4236 ext. Fax: (407) 384-4020
4. Application Contact Email Address: dstalls@ouc.com

Application Processing Information (DEP Use)

1. Date of Receipt of Application: 3/17/08
2. Project Number(s): 0950137-021-AC
3. PSD Number (if applicable):
4. Siting Number (if applicable):

APPLICATION INFORMATION

Purpose of Application

This application for air permit is submitted to obtain: (Check one)

Air Construction Permit

- Air construction permit.
- Air construction permit to establish, revise, or renew a plantwide applicability limit (PAL).
- Air construction permit to establish, revise, or renew a plantwide applicability limit (PAL), and separate air construction permit to authorize construction or modification of one or more emissions units covered by the PAL.

Air Operation Permit

- Initial Title V air operation permit.
- Title V air operation permit revision.
- Title V air operation permit renewal.
- Initial federally enforceable state air operation permit (FESOP) where professional engineer (PE) certification is required.
- Initial federally enforceable state air operation permit (FESOP) where professional engineer (PE) certification is not required.

Air Construction Permit and Revised/Renewal Title V Air Operation Permit (Concurrent Processing)

- Air construction permit and Title V permit revision, incorporating the proposed project.
- Air construction permit and Title V permit renewal, incorporating the proposed project.

Note: By checking one of the above two boxes, you, the applicant, are requesting concurrent processing pursuant to Rule 62-213.405, F.A.C. In such case, you must also check the following box:

- I hereby request that the department waive the processing time requirements of the air construction permit to accommodate the processing time frames of the Title V air operation permit.

Application Comment

OUC wishes to replace the existing tradition baghouse (E.U. ID No. -010 Coal Reclaim Hopper Baghouse) with a new insertable dust collector located inside the tunnel shortly after the transfer point to coal Conveyor #5. The insertable dust collector will capture dust on a series of filters and periodically reverse air pulse the filters so as to return the collected dust to the main body of material rather than transport dust laden air to a central baghouse system. This new insertable dust collector will have no direct vent to the atmosphere and any emissions would be considered negligible especially after the further mitigation of its location underground within the coal system dust work.

Owner/Authorized Representative Statement

Complete if applying for an air construction permit or an initial FESOP.

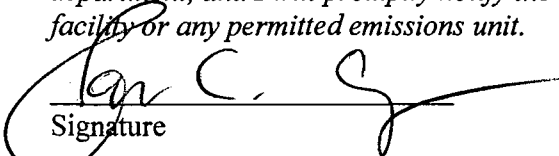
1. Owner/Authorized Representative Name: Jan C. Aspuru VP, Power Resources
2. Owner/Authorized Representative Mailing Address... Organization/Firm: Orlando Utilities Commission Street Address: P.O. Box 3193 City: Orlando State: FL Zip Code: 32802
3. Owner/Authorized Representative Telephone Numbers... Telephone: (407) 658-6444 ext. Fax: (407) 275-4120
4. Owner/Authorized Representative Email Address: jaspuru@ouc.com
5. Owner/Authorized Representative Statement: <i>I, the undersigned, am the owner or authorized representative of the facility addressed in this air permit application. I hereby certify, based on information and belief formed after reasonable inquiry, that the statements made in this application are true, accurate and complete and that, to the best of my knowledge, any estimates of emissions reported in this application are based upon reasonable techniques for calculating emissions. The air pollutant emissions units and air pollution control equipment described in this application will be operated and maintained so as to comply with all applicable standards for control of air pollutant emissions found in the statutes of the State of Florida and rules of the Department of Environmental Protection and revisions thereof and all other requirements identified in this application to which the facility is subject. I understand that a permit, if granted by the department, cannot be transferred without authorization from the department, and I will promptly notify the department upon sale or legal transfer of the facility or any permitted emissions unit.</i>  Signature <u>March 11, 2009</u> Date

Application Responsible Official Certification

Complete if applying for an initial/revise/renewal Title V permit or concurrent processing of an air construction permit and a revised/renewal Title V permit. If there are multiple responsible officials, the "application responsible official" need not be the "primary responsible official."

1. Application Responsible Official Name:
2. Application Responsible Official Qualification (Check one or more of the following options, as applicable): <input type="checkbox"/> For a corporation, the president, secretary, treasurer, or vice-president of the corporation in charge of a principal business function, or any other person who performs similar policy or decision-making functions for the corporation, or a duly authorized representative of such person if the representative is responsible for the overall operation of one or more manufacturing, production, or operating facilities applying for or subject to a permit under Chapter 62-213, F.A.C. <input type="checkbox"/> For a partnership or sole proprietorship, a general partner or the proprietor, respectively. <input type="checkbox"/> For a municipality, county, state, federal, or other public agency, either a principal executive officer or ranking elected official. <input type="checkbox"/> The designated representative at an Acid Rain source.
3. Application Responsible Official Mailing Address... Organization/Firm: Street Address: City: State: Zip Code:
4. Application Responsible Official Telephone Numbers... Telephone: () - ext. Fax: () -
5. Application Responsible Official Email Address:
6. Application Responsible Official Certification: <i>I, the undersigned, am a responsible official of the Title V source addressed in this air permit application. I hereby certify, based on information and belief formed after reasonable inquiry, that the statements made in this application are true, accurate and complete and that, to the best of my knowledge, any estimates of emissions reported in this application are based upon reasonable techniques for calculating emissions. The air pollutant emissions units and air pollution control equipment described in this application will be operated and maintained so as to comply with all applicable standards for control of air pollutant emissions found in the statutes of the State of Florida and rules of the Department of Environmental Protection and revisions thereof and all other applicable requirements identified in this application to which the Title V source is subject. I understand that a permit, if granted by the department, cannot be transferred without authorization from the department, and I will promptly notify the department upon sale or legal transfer of the facility or any permitted emissions unit. Finally, I certify that the facility and each emissions unit are in compliance with all applicable requirements to which they are subject, except as identified in compliance plan(s) submitted with this application.</i> _____ Signature _____ Date

Professional Engineer Certification

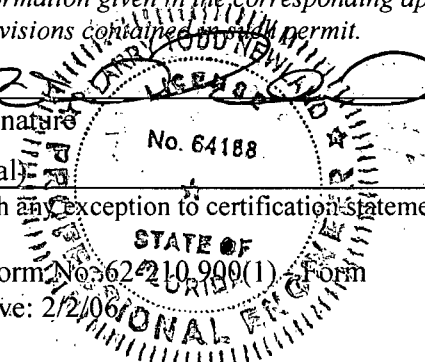
1. Professional Engineer Name: Larry T. Newland Registration Number: 64188	
2. Professional Engineer Mailing Address... Organization/Firm: Black & Veatch Street Address: 9000 Regency Parkway, Suite 300 City: Cary State: NC Zip Code: 27518	
3. Professional Engineer Telephone Numbers... Telephone: (919) 462-7415 ext. Fax: (919) 468-9212	
4. Professional Engineer Email Address: newlandlt@bv.com	
5. Professional Engineer Statement: <i>I, the undersigned, hereby certify, except as particularly noted herein*, that:</i> (1) <i>To the best of my knowledge, there is reasonable assurance that the air pollutant emissions unit(s) and the air pollution control equipment described in this application for air permit, when properly operated and maintained, will comply with all applicable standards for control of air pollutant emissions found in the Florida Statutes and rules of the Department of Environmental Protection; and</i> (2) <i>To the best of my knowledge, any emission estimates reported or relied on in this application are true, accurate, and complete and are either based upon reasonable techniques available for calculating emissions or, for emission estimates of hazardous air pollutants not regulated for an emissions unit addressed in this application, based solely upon the materials, information and calculations submitted with this application.</i> (3) <i>If the purpose of this application is to obtain a Title V air operation permit (check here <input checked="" type="checkbox"/>, if so), I further certify that each emissions unit described in this application for air permit, when properly operated and maintained, will comply with the applicable requirements identified in this application to which the unit is subject, except those emissions units for which a compliance plan and schedule is submitted with this application.</i> (4) <i>If the purpose of this application is to obtain an air construction permit (check here <input type="checkbox"/>, if so) or concurrently process and obtain an air construction permit and a Title V air operation permit revision or renewal for one or more proposed new or modified emissions units (check here <input type="checkbox"/>, if so), I further certify that the engineering features of each such emissions unit described in this application have been designed or examined by me or individuals under my direct supervision and found to be in conformity with sound engineering principles applicable to the control of emissions of the air pollutants characterized in this application.</i> (5) <i>If the purpose of this application is to obtain an initial air operation permit or operation permit revision or renewal for one or more newly constructed or modified emissions units (check here <input type="checkbox"/>, if so), I further certify that, with the exception of any changes detailed as part of this application, each such emissions unit has been constructed or modified in substantial accordance with the information given in the corresponding application for air construction permit and with all provisions contained in such permit.</i>	
Signature:  (seal): 	Date: <u>05.10.08</u>

* Attach any exception to certification statement.

FACILITY INFORMATION

Facility Regulatory Classifications

Check all that would apply *following* completion of all projects and implementation of all other changes proposed in this application for air permit. Refer to instructions to distinguish between a “major source” and a “synthetic minor source.”

1. <input type="checkbox"/> Small Business Stationary Source	<input type="checkbox"/> Unknown
2. <input type="checkbox"/> Synthetic Non-Title V Source	
3. <input checked="" type="checkbox"/> Title V Source	
4. <input checked="" type="checkbox"/> Major Source of Air Pollutants, Other than Hazardous Air Pollutants (HAPs)	
5. <input type="checkbox"/> Synthetic Minor Source of Air Pollutants, Other than HAPs	
6. <input type="checkbox"/> Major Source of Hazardous Air Pollutants (HAPs)	
7. <input type="checkbox"/> Synthetic Minor Source of HAPs	
8. <input checked="" type="checkbox"/> One or More Emissions Units Subject to NSPS (40 CFR Part 60)	
9. <input type="checkbox"/> One or More Emissions Units Subject to Emission Guidelines (40 CFR Part 60)	
10. <input type="checkbox"/> One or More Emissions Units Subject to NESHAP (40 CFR Part 61 or Part 63)	
11. <input type="checkbox"/> Title V Source Solely by EPA Designation (40 CFR 70.3(a)(5))	
12. Facility Regulatory Classifications Comment:	

FACILITY INFORMATION

C. FACILITY ADDITIONAL INFORMATION

Additional Requirements for All Applications, Except as Otherwise Stated

1. Facility Plot Plan: (Required for all permit applications, except Title V air operation permit revision applications if this information was submitted to the department within the previous five years and would not be altered as a result of the revision being sought) <input checked="" type="checkbox"/> Attached, Document ID: <u>Attach. A</u> <input type="checkbox"/> Previously Submitted, Date: _____
2. Process Flow Diagram(s): (Required for all permit applications, except Title V air operation permit revision applications if this information was submitted to the department within the previous five years and would not be altered as a result of the revision being sought) <input checked="" type="checkbox"/> Attached, Document ID: <u>Attach. B</u> <input type="checkbox"/> Previously Submitted, Date: _____
3. Precautions to Prevent Emissions of Unconfined Particulate Matter: (Required for all permit applications, except Title V air operation permit revision applications if this information was submitted to the department within the previous five years and would not be altered as a result of the revision being sought) <input checked="" type="checkbox"/> Attached, Document ID: <u>Attach. C</u> <input type="checkbox"/> Previously Submitted, Date: _____

Additional Requirements for Air Construction Permit Applications

1. Area Map Showing Facility Location: <input type="checkbox"/> Attached, Document ID: _____ <input checked="" type="checkbox"/> Not Applicable (existing permitted facility)
2. Description of Proposed Construction, Modification, or Plantwide Applicability Limit (PAL): <input checked="" type="checkbox"/> Attached, Document ID: <u>Attach. D</u>
3. Rule Applicability Analysis: <input checked="" type="checkbox"/> Attached, Document ID: <u>Attach. E</u>
4. List of Exempt Emissions Units (Rule 62-210.300(3), F.A.C.): <input checked="" type="checkbox"/> Attached, Document ID: <u>Attach. F</u> <input type="checkbox"/> Not Applicable (no exempt units at facility)
5. Fugitive Emissions Identification: <input checked="" type="checkbox"/> Attached, Document ID: <u>Attach. G</u> <input type="checkbox"/> Not Applicable
6. Air Quality Analysis (Rule 62-212.400(7), F.A.C.): <input type="checkbox"/> Attached, Document ID: _____ <input checked="" type="checkbox"/> Not Applicable
7. Source Impact Analysis (Rule 62-212.400(5), F.A.C.): <input type="checkbox"/> Attached, Document ID: _____ <input checked="" type="checkbox"/> Not Applicable
8. Air Quality Impact since 1977 (Rule 62-212.400(4)(e), F.A.C.): <input type="checkbox"/> Attached, Document ID: _____ <input checked="" type="checkbox"/> Not Applicable
9. Additional Impact Analyses (Rules 62-212.400(8) and 62-212.500(4)(e), F.A.C.): <input type="checkbox"/> Attached, Document ID: _____ <input checked="" type="checkbox"/> Not Applicable
10. Alternative Analysis Requirement (Rule 62-212.500(4)(g), F.A.C.): <input type="checkbox"/> Attached, Document ID: _____ <input checked="" type="checkbox"/> Not Applicable

EMISSIONS UNIT INFORMATION

Section [1] of [1]

III. EMISSIONS UNIT INFORMATION

Title V Air Operation Permit Application - For Title V air operation permitting only, emissions units are classified as regulated, unregulated, or insignificant. If this is an application for Title V air operation permit, a separate Emissions Unit Information Section (including subsections A through I as required) must be completed for each regulated and unregulated emissions unit addressed in this application for air permit. Some of the subsections comprising the Emissions Unit Information Section of the form are optional for unregulated emissions units. Each such subsection is appropriately marked. Insignificant emissions units are required to be listed at Section II, Subsection C.

Air Construction Permit or FESOP Application - For air construction permitting or federally enforceable state air operation permitting, emissions units are classified as either subject to air permitting or exempt from air permitting. The concept of an "unregulated emissions unit" does not apply. If this is an application for air construction permit or FESOP, a separate Emissions Unit Information Section (including subsections A through I as required) must be completed for each emissions unit subject to air permitting addressed in this application for air permit. Emissions units exempt from air permitting are required to be listed at Section II, Subsection C.

Air Construction Permit and Revised/Renewal Title V Air Operation Permit Application - Where this application is used to apply for both an air construction permit and a revised/renewal Title V air operation permit, each emissions unit is classified as either subject to air permitting or exempt from air permitting for air construction permitting purposes and as regulated, unregulated, or insignificant for Title V air operation permitting purposes. **The air construction permitting classification must be used to complete the Emissions Unit Information Section of this application for air permit.** A separate Emissions Unit Information Section (including subsections A through I as required) must be completed for each emissions unit subject to air permitting addressed in this application for air permit. Emissions units exempt from air construction permitting and insignificant emissions units are required to be listed at Section II, Subsection C.

If submitting the application form in hard copy, the number of this Emissions Unit Information Section and the total number of Emissions Unit Information Sections submitted as part of this application must be indicated in the space provided at the top of each page.

EMISSIONS UNIT INFORMATION

Section [1] of [1]

A. GENERAL EMISSIONS UNIT INFORMATION

Title V Air Operation Permit Emissions Unit Classification

1. Regulated or Unregulated Emissions Unit? (Check one, if applying for an initial, revised or renewal Title V air operation permit. Skip this item if applying for an air construction permit or FESOP only.)

The emissions unit addressed in this Emissions Unit Information Section is a regulated emissions unit.

The emissions unit addressed in this Emissions Unit Information Section is an unregulated emissions unit.

Emissions Unit Description and Status

1. Type of Emissions Unit Addressed in this Section: (Check one)

This Emissions Unit Information Section addresses, as a single emissions unit, a single process or production unit, or activity, which produces one or more air pollutants and which has at least one definable emission point (stack or vent). **(NOTE: the Insertable Dust Collector does not vent directly to the atmosphere; it is contained underground within the conveying tunnel)**

This Emissions Unit Information Section addresses, as a single emissions unit, a group of process or production units and activities which has at least one definable emission point (stack or vent) but may also produce fugitive emissions.

This Emissions Unit Information Section addresses, as a single emissions unit, one or more process or production units and activities which produce fugitive emissions only.

2. Description of Emissions Unit Addressed in this Section: Coal Reclaim Hopper Insertable Dust Collector

3. Emissions Unit Identification Number:

4. Emissions Unit Status Code:	5. Commence Construction Date:	6. Initial Startup Date:	7. Emissions Unit Major Group SIC Code	8. Acid Rain Unit? <input type="checkbox"/> Yes <input checked="" type="checkbox"/> No
--------------------------------	--------------------------------	--------------------------	--	--

9. Package Unit:
Manufacturer: _____ Model Number: _____

10. Generator Nameplate Rating: MW

11. Emissions Unit Comment:
This emission control device collects dust laden air on its fabric filters with a integral fan. Filter elements are periodically cleaned by a reverse jet of compressed air resulting in a brief inflation of the filter element dislodging the dust cake back into the main material body rather than transporting the dust to a central collection point for disposal. This is a self-contained unit that is operated inline with the material duct work underground. It does not vent directly to the atmosphere. As such, emissions are expected to be negligible.

EMISSIONS UNIT INFORMATION

Section [1] of [1]

Emissions Unit Control Equipment

1. Control Equipment/Method(s) Description:
Fabric Filter – Low Temperature

2. Control Device or Method Code(s): 018

EMISSIONS UNIT INFORMATION

Section [1] of [1]

B. EMISSIONS UNIT CAPACITY INFORMATION

(Optional for unregulated emissions units.)

Emissions Unit Operating Capacity and Schedule

1. Maximum Process or Throughput Rate: 1,800 ton per hour
2. Maximum Production Rate:
3. Maximum Heat Input Rate: million Btu/hr
4. Maximum Incineration Rate: pounds/hr tons/day
5. Requested Maximum Operating Schedule: 24 hours/day 7 days/week 52 weeks/year 8,760 hours/year
6. Operating Capacity/Schedule Comment:

EMISSIONS UNIT INFORMATION

Section [1] of [1]

**C. EMISSION POINT (STACK/VENT) INFORMATION
(Optional for unregulated emissions units.)****Emission Point Description and Type**

1. Identification of Point on Plot Plan or Flow Diagram: 010A		2. Emission Point Type Code: 1	
3. Descriptions of Emission Points Comprising this Emissions Unit for VE Tracking:			
4. ID Numbers or Descriptions of Emission Units with this Emission Point in Common:			
5. Discharge Type Code:	6. Stack Height: No defined stack to ambient air	7. Exit Diameter: Feet	
8. Exit Temperature: 77 °F	9. Actual Volumetric Flow Rate: TBD acfm	10. Water Vapor: %	
11. Maximum Dry Standard Flow Rate: Dscfm		12. Nonstack Emission Point Height: feet	
13. Emission Point UTM Coordinates... Zone: East (km): North (km):		14. Emission Point Latitude/Longitude... Latitude (DD/MM/SS) Longitude (DD/MM/SS)	
15. Emission Point Comment:			

EMISSIONS UNIT INFORMATION

Section [1] of [1]

D. SEGMENT (PROCESS/FUEL) INFORMATION

Segment Description and Rate: Segment 1 of 1

1. Segment Description (Process/Fuel Type): Handling of Solid Fuel		
2. Source Classification Code (SCC): 30501099		3. SCC Units: Tons transferred or handled
4. Maximum Hourly Rate: 1,800	5. Maximum Annual Rate: 4,260,000	6. Estimated Annual Activity Factor:
7. Maximum % Sulfur:	8. Maximum % Ash:	9. Million Btu per SCC Unit:
10. Segment Comment:		

Segment Description and Rate: Segment of

1. Segment Description (Process/Fuel Type):		
2. Source Classification Code (SCC):		3. SCC Units:
4. Maximum Hourly Rate:	5. Maximum Annual Rate:	6. Estimated Annual Activity Factor:
7. Maximum % Sulfur:	8. Maximum % Ash:	9. Million Btu per SCC Unit:
10. Segment Comment:		

EMISSIONS UNIT INFORMATION

Section [1] of [1]

D. SEGMENT (PROCESS/FUEL) INFORMATION (CONTINUED)

Segment Description and Rate: Segment __ of __

1. Segment Description (Process/Fuel Type):		
2. Source Classification Code (SCC):		3. SCC Units:
4. Maximum Hourly Rate:	5. Maximum Annual Rate:	6. Estimated Annual Activity Factor:
7. Maximum % Sulfur:	8. Maximum % Ash:	9. Million Btu per SCC Unit:
10. Segment Comment:		

Segment Description and Rate: Segment __ of __

1. Segment Description (Process/Fuel Type):		
2. Source Classification Code (SCC):		3. SCC Units:
4. Maximum Hourly Rate:	5. Maximum Annual Rate:	6. Estimated Annual Activity Factor:
7. Maximum % Sulfur:	8. Maximum % Ash:	9. Million Btu per SCC Unit:
10. Segment Comment:		

**F1. EMISSIONS UNIT POLLUTANT DETAIL INFORMATION –
POTENTIAL, FUGITIVE, AND ACTUAL EMISSIONS**

(Optional for unregulated emissions units.)

Potential, Estimated Fugitive, and Baseline & Projected Actual Emissions

Complete for each pollutant identified in Subsection E if applying for an air construction permit or concurrent processing of an air construction permit and a revised or renewal Title V permit. Complete for each emissions-limited pollutant identified in Subsection E if applying for an air operation permit.

1. Pollutant Emitted: PM/PM10		2. Total Percent Efficiency of Control:	
3. Potential Emissions: Negligible		4. Synthetically Limited? <input type="checkbox"/> Yes <input type="checkbox"/> No	
5. Range of Estimated Fugitive Emissions (as applicable): to tons/year			
6. Emission Factor: Reference:		7. Emissions Method Code:	
8.a. Baseline Actual Emissions (if required): tons/year		8.b. Baseline 24-month Period: From: To:	
9.a. Projected Actual Emissions (if required): tons/year		9.b. Projected Monitoring Period: <input type="checkbox"/> 5 years <input type="checkbox"/> 10 years	
10. Calculation of Emissions: Unit will be located inline of the coal tunnel and will not vent directly to the atmosphere. As such, emissions are expected to be negligible.			
11. Potential, Fugitive, and Actual Emissions Comment:			

**F2. EMISSIONS UNIT POLLUTANT DETAIL INFORMATION -
 ALLOWABLE EMISSIONS**

Complete if the pollutant identified in Subsection F1 is or would be subject to a numerical emissions limitation.

Allowable Emissions Allowable Emissions __ of __

1. Basis for Allowable Emissions Code:	2. Future Effective Date of Allowable Emissions:
3. Allowable Emissions and Units:	4. Equivalent Allowable Emissions: lb/hour tons/year
5. Method of Compliance:	
6. Allowable Emissions Comment (Description of Operating Method):	

Allowable Emissions Allowable Emissions __ of __

1. Basis for Allowable Emissions Code:	2. Future Effective Date of Allowable Emissions:
3. Allowable Emissions and Units:	4. Equivalent Allowable Emissions: lb/hour tons/year
5. Method of Compliance:	
6. Allowable Emissions Comment (Description of Operating Method):	

Allowable Emissions Allowable Emissions __ of __

1. Basis for Allowable Emissions Code:	2. Future Effective Date of Allowable Emissions:
3. Allowable Emissions and Units:	4. Equivalent Allowable Emissions: lb/hour tons/year
5. Method of Compliance:	
6. Allowable Emissions Comment (Description of Operating Method):	

EMISSIONS UNIT INFORMATION

Section [1] of [1]

H. CONTINUOUS MONITOR INFORMATION

Complete if this emissions unit is or would be subject to continuous monitoring.

Continuous Monitoring System: Continuous Monitor ___ of ___

1. Parameter Code:	2. Pollutant(s):
3. CMS Requirement:	<input type="checkbox"/> Rule <input type="checkbox"/> Other
4. Monitor Information... Manufacturer: Model Number: Serial Number:	
5. Installation Date:	6. Performance Specification Test Date:
7. Continuous Monitor Comment:	

Continuous Monitoring System: Continuous Monitor ___ of ___

1. Parameter Code:	2. Pollutant(s):
3. CMS Requirement:	<input type="checkbox"/> Rule <input type="checkbox"/> Other
4. Monitor Information... Manufacturer: Model Number: Serial Number:	
5. Installation Date:	6. Performance Specification Test Date:
7. Continuous Monitor Comment:	

EMISSIONS UNIT INFORMATION

Section [1] of [1]

H. CONTINUOUS MONITOR INFORMATION (CONTINUED)

Complete if this emissions unit is or would be subject to continuous monitoring.

Continuous Monitoring System: Continuous Monitor ___ of ___

1. Parameter Code:	2. Pollutant(s):
3. CMS Requirement:	<input type="checkbox"/> Rule <input type="checkbox"/> Other
4. Monitor Information... Manufacturer: Model Number: Serial Number:	
5. Installation Date:	6. Performance Specification Test Date:
7. Continuous Monitor Comment:	

Continuous Monitoring System: Continuous Monitor ___ of ___

1. Parameter Code:	2. Pollutant(s):
3. CMS Requirement:	<input type="checkbox"/> Rule <input type="checkbox"/> Other
4. Monitor Information... Manufacturer: Model Number: Serial Number:	
5. Installation Date:	6. Performance Specification Test Date:
7. Continuous Monitor Comment:	

EMISSIONS UNIT INFORMATION

Section [1] of [1]

I. EMISSIONS UNIT ADDITIONAL INFORMATION

Additional Requirements for All Applications, Except as Otherwise Stated

1. Process Flow Diagram (Required for all permit applications, except Title V air operation permit revision applications if this information was submitted to the department within the previous five years and would not be altered as a result of the revision being sought) <input type="checkbox"/> Attached, Document ID: _____ <input type="checkbox"/> Previously Submitted, Date _____
2. Fuel Analysis or Specification (Required for all permit applications, except Title V air operation permit revision applications if this information was submitted to the department within the previous five years and would not be altered as a result of the revision being sought) <input type="checkbox"/> Attached, Document ID: _____ <input type="checkbox"/> Previously Submitted, Date _____
3. Detailed Description of Control Equipment (Required for all permit applications, except Title V air operation permit revision applications if this information was submitted to the department within the previous five years and would not be altered as a result of the revision being sought) <input checked="" type="checkbox"/> Attached, Document ID: <u>Attach. H</u> <input type="checkbox"/> Previously Submitted, Date _____
4. Procedures for Startup and Shutdown (Required for all operation permit applications, except Title V air operation permit revision applications if this information was submitted to the department within the previous five years and would not be altered as a result of the revision being sought) <input type="checkbox"/> Attached, Document ID: _____ <input type="checkbox"/> Previously Submitted, Date _____ <input checked="" type="checkbox"/> Not Applicable (construction application)
5. Operation and Maintenance Plan (Required for all permit applications, except Title V air operation permit revision applications if this information was submitted to the department within the previous five years and would not be altered as a result of the revision being sought) <input checked="" type="checkbox"/> Attached, Document ID: <u>Attach. I</u> <input type="checkbox"/> Previously Submitted, Date _____ <input type="checkbox"/> Not Applicable
6. Compliance Demonstration Reports/Records <input type="checkbox"/> Attached, Document ID: _____ Test Date(s)/Pollutant(s) Tested: _____ <input type="checkbox"/> Previously Submitted, Date: _____ Test Date(s)/Pollutant(s) Tested: _____ <input type="checkbox"/> To be Submitted, Date (if known): _____ Test Date(s)/Pollutant(s) Tested: _____ <input checked="" type="checkbox"/> Not Applicable Note: For FESOP applications, all required compliance demonstration records/reports must be submitted at the time of application. For Title V air operation permit applications, all required compliance demonstration reports/records must be submitted at the time of application, or a compliance plan must be submitted at the time of application.
7. Other Information Required by Rule or Statute <input type="checkbox"/> Attached, Document ID: _____ <input checked="" type="checkbox"/> Not Applicable

EMISSIONS UNIT INFORMATION

Section [1] of [1]

Additional Requirements for Air Construction Permit Applications

1. Control Technology Review and Analysis (Rules 62-212.400(10) and 62-212.500(7), F.A.C.; 40 CFR 63.43(d) and (e)) <input type="checkbox"/> Attached, Document ID: _____ <input checked="" type="checkbox"/> Not Applicable
2. Good Engineering Practice Stack Height Analysis (Rule 62-212.400(4)(d), F.A.C., and Rule 62-212.500(4)(f), F.A.C.) <input type="checkbox"/> Attached, Document ID: _____ <input checked="" type="checkbox"/> Not Applicable
3. Description of Stack Sampling Facilities (Required for proposed new stack sampling facilities only) <input type="checkbox"/> Attached, Document ID: _____ <input checked="" type="checkbox"/> Not Applicable

Additional Requirements for Title V Air Operation Permit Applications

1. Identification of Applicable Requirements <input type="checkbox"/> Attached, Document ID: _____
2. Compliance Assurance Monitoring <input type="checkbox"/> Attached, Document ID: _____ <input type="checkbox"/> Not Applicable
3. Alternative Methods of Operation <input type="checkbox"/> Attached, Document ID: _____ <input type="checkbox"/> Not Applicable
4. Alternative Modes of Operation (Emissions Trading) <input type="checkbox"/> Attached, Document ID: _____ <input type="checkbox"/> Not Applicable
5. Acid Rain Part Application <input type="checkbox"/> Certificate of Representation (EPA Form No. 7610-1) <input type="checkbox"/> Copy Attached, Document ID: _____ <input type="checkbox"/> Acid Rain Part (Form No. 62-210.900(1)(a)) <input type="checkbox"/> Attached, Document ID: _____ <input type="checkbox"/> Previously Submitted, Date: _____ <input type="checkbox"/> Repowering Extension Plan (Form No. 62-210.900(1)(a)1.) <input type="checkbox"/> Attached, Document ID: _____ <input type="checkbox"/> Previously Submitted, Date: _____ <input type="checkbox"/> New Unit Exemption (Form No. 62-210.900(1)(a)2.) <input type="checkbox"/> Attached, Document ID: _____ <input type="checkbox"/> Previously Submitted, Date: _____ <input type="checkbox"/> Retired Unit Exemption (Form No. 62-210.900(1)(a)3.) <input type="checkbox"/> Attached, Document ID: _____ <input type="checkbox"/> Previously Submitted, Date: _____ <input type="checkbox"/> Phase II NOx Compliance Plan (Form No. 62-210.900(1)(a)4.) <input type="checkbox"/> Attached, Document ID: _____ <input type="checkbox"/> Previously Submitted, Date: _____ <input type="checkbox"/> Phase II NOx Averaging Plan (Form No. 62-210.900(1)(a)5.) <input type="checkbox"/> Attached, Document ID: _____ <input type="checkbox"/> Previously Submitted, Date: _____ <input type="checkbox"/> Not Applicable

Additional Requirements Comment

EMISSIONS UNIT INFORMATION

Attachment A

Facility Plot Plan

Attachment B

Process Flow Diagram

S35459-HI

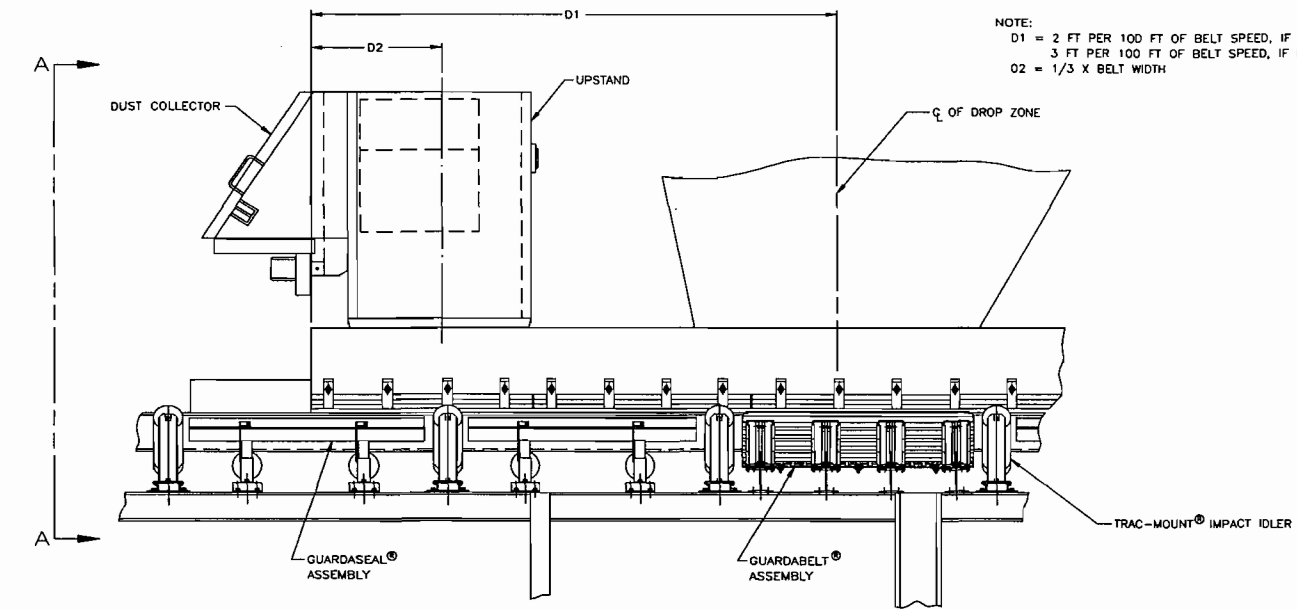

NOTE:
 D1 = 2 FT PER 100 FT OF BELT SPEED, IF LOW POSITIVE PRESSURE.
 3 FT PER 100 FT OF BELT SPEED, IF HIGH POSITIVE PRESSURE.
 D2 = 1/3 X BELT WIDTH

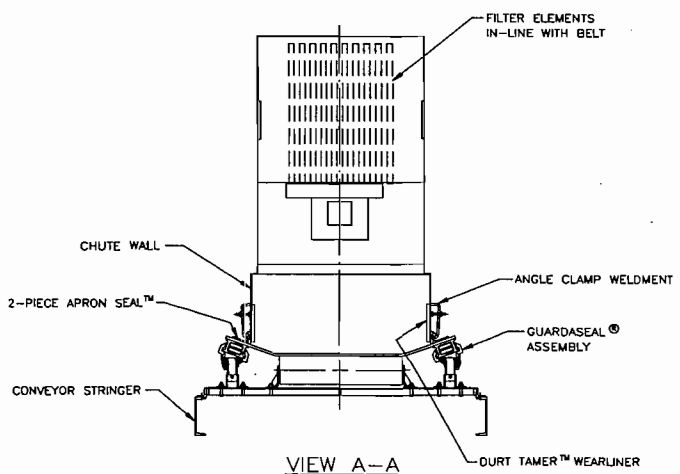

VIEW A-A

© Copyright 1998 Martin Engineering. All rights reserved. Covered by U.S. and foreign patents pending and issued. ® and TM indicate trademarks of Martin Engineering.

MARTIN ENGINEERING NEPONSET ILLINOIS USA

TITLE	INSERTABLE DUST COLLECTOR WITH HORIZONTAL UPSTAND (IN-LINE WITH BELT)	DRAWN MJT
		DATE 04/17/98
		CHECKED
		ENG. JCF
		DATE 04/23/98
		APPROVED JES
		DATE 04/23/98
		SCALE 1/16

NO.	DESCRIPTION	DATE	BY
	REVISION		

SALES DRAWING

S35459-HI

LL\SAL\S35459HI

Attachment C

Precautions to Prevent Emissions of Unconfined Particulate Matter

Precautions to Prevent Emissions of Unconfined Particulate Matter

The following reasonable precautions are taken to prevent emissions of unconfined particulate matter on an as-needed basis:

- Paving and maintenance of roads, parking areas, and yards,
- Chemical (dust suppressants) or water application to unpaved roads, and unpaved yard areas,
- Removal of particulate matter (PM) from roads and other paved areas to prevent re-entrainment, and from buildings or work areas to prevent airborne PM,
- Landscaping or planting of vegetation,
- Regular mowing of grass and care of vegetation,
- Confining abrasive blasting where possible,
- Limiting access to plant property by unnecessary vehicles, and
- Additional, or alternative activities, or other techniques to minimize unconfined PM emissions.

Attachment D

Description of Proposed Construction or Modification

Description of Proposed Construction or Modification

OUC requests FDEP approval for the replacement of the existing Coal Reclaim Hopper Baghouse (E.U. ID No. -010). The existing system is located near the Emergency Coal Pile and frequently becomes packed with coal up to the level of the motor. In order to alleviate this issue, OUC proposes to replace this above-ground baghouse with an inline Insertable Dust Collector located within the tunnel.

The new dust collector will be installed inside the transfer point enclosure, so that it can operate without ducting or the high-powered fans typically required to move dust-laden air to a central baghouse. The new dust collection system is designed to capture airborne particles and return them to the main body or material without the use of additional dust handling equipment. Periodic cleaning of the filters is accomplished with an automatic reverse jet of compressed air into the filter bags. This will create a momentary reversal of air flow, inflating the filter element to dislodge the accumulated dust. The collected filter cake will return to the main material stream. Because of this unique design and its location directly inside the chute work, the Insertable Dust Collector will not vent dust to the atmosphere; all collected dust is returned to the material conveying system. Therefore, there will no longer be an atmospheric vent (i.e., source of dust to the atmosphere) due to the replacement of the existing dust collector with this new system.

Attachment E

Rule Applicability Analysis

Rule Applicability Analysis

The following rule applicability analysis is limited to the rules associated with the proposed facility change and does not encompass overall facility rule applicability. Overall facility applicable requirements were identified in the latest Title V permit application.

Rule Applicability Analysis for the new Insertable Dust Collector (note that the dust collector does not directly vent to the atmosphere and as such no testing requirements are expected of the unit including opacity)

Federal: 40 CFR Part 60, Subpart Y – *Standards of Performance for Coal Preparation Plant* since Stanton has coal processing and conveying equipment and the facility commenced construction after October 24, 1974.

Federal: 40 CFR Part 60, Subpart A – *General Provisions*.

State: Rule 62-4.070 – *Standards for Issuing or Denying Permits*.

State: Rule 62-204.800(8)(b).31 – *General Provisions Adopted – 40 CFR 60 Subpart A – General Provisions adopted by reference, with exceptions*.

State: Rule 62-204.800(8)(d) – *Standards of Performance for Coal Preparation Plants Adopted – 40 CFR 60 Subpart Y adopted by reference*.

State: Rule 62-210.300 – *Permits Required*.

State: Rule 62-212.300 – *General Preconstruction Review Requirements*.

Attachment F

List of Exempt Emission Units

List of Exempt Emission Units

This application does not affect the existing list of exempt emission units at this facility.

Attachment G

Fugitive Emissions Identification

Fugitive Emissions Identification

No new fugitive emissions sources are anticipated as a result of this application.

Attachment H

Detailed Description of Control Equipment

Detailed Description of Control Equipment

The transmittal letter, Attachment D, and the following vendor-provided information sheet contain descriptions of the proposed control equipment.



MARTIN®

Insertable Dust Collector

To overcome the maintenance problems and operating costs of centralized dust control systems, Martin Engineering recommends the use of insertable dust collectors on conveyor transfer points.

Rather than carry dust-laden air to a central collector, insertable systems filter the air inside the transfer point. There is no large fan, no ductwork, and no central bag house. Insertable filters are integrated into the transfer point enclosure, where they can easily return material to the conveying system.

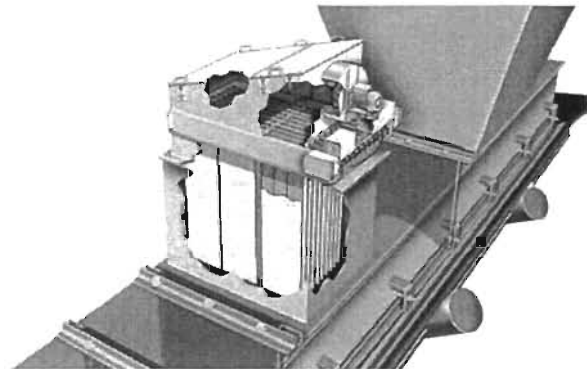

BENEFITS

- **Effective Dust Capture**
High efficiency filters remove 99.9 percent of all particles larger than one micron.
- **Continuous Operation**
Automatic "reverse jet" cleaning sequence keeps filters working effectively with minimum compressed air.
- **Returns Product To The Process**
Dust stays within the transfer point. Valuable material returns to the material handling system.
- **No Dust Disposal**
No haulage costs for waste disposal. Valuable material returns to the process. No equipment needed to handle, package, or dispose of dust.
- **Economical Installation**
No ductwork to install, balance, or clean.
- **Low Energy Costs**
Small, efficient integral fan operates only when conveyor runs.
- **Compact Design**
Small "footprint" reduces space requirements and installation cost.
- **Minimum Maintenance**
"Clean side" access for inspection and filter changeout.
- **Flexible Design**
Stand-alone system or use to supplement existing central dust collector systems.

DESIGNED EFFICIENCY

Insertable collectors can effectively handle the heavy concentrations of dust and high volumes of air arising at belt conveyor transfer points.

DCE Dalmatic® (MARTIN®) Insertable Dust Collectors are designed to remove 99.9 percent by weight of

all dry particulate particles one micron and larger in size.

(This efficiency is based on a time-weighted average and assures the collector will be installed, operated, and maintained in accordance with instructions.)

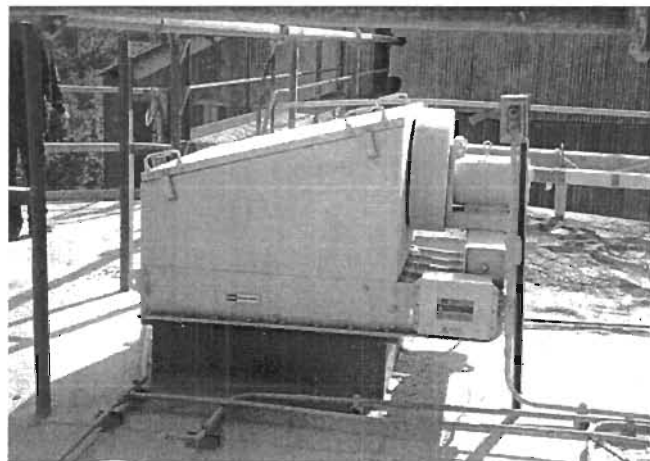

HOW IT WORKS

An integral fan pulls dust-laden air through the filter elements. The air passes through the filter, leaving the particles on the fabric.

Each filter element is regularly cleaned by a "reverse jet" of compressed air, which is injected into the filter element through the jet tube. This causes a momentary reversal of the air flow, resulting in a brief inflation of the filter element, dislodging the dust cake back into the main material body.

SYSTEMS TO FIT YOUR APPLICATION

Martin Engineering offers a full range of system sizes and filter materials to match application requirements. Filters can be installed horizontally or vertically to meet application requirements. Explosion-proof packages are available.

SIZING

Sizing requires measurements of air flow, material conveyed, temperature of material, frequency, and voltage.

The best way to measure the air velocity is to use a hand held anemometer. This small electronic device will provide a display of average velocity of the air in feet per minute. By placing the anemometer in the flow of the air as it exits the end of the transfer point chute, the air velocity for the transfer point can be determined.

Once the air velocity is determined, the cross sectional area of the transfer point chute must be measured. This should be recorded in units of feet. Once this area is determined, the area in square feet is multiplied by the air velocity in feet per minute to determine the air volume through the transfer point.

Actual size of dust collector will vary, depending on measured air flow, type of material being collected, and material drop height.

Explosion-proof units are supplied with explosion-proof fan motor, spark-resistant fan, NEMA 9 control panel, anti-static filter media, and stainless steel inserts.

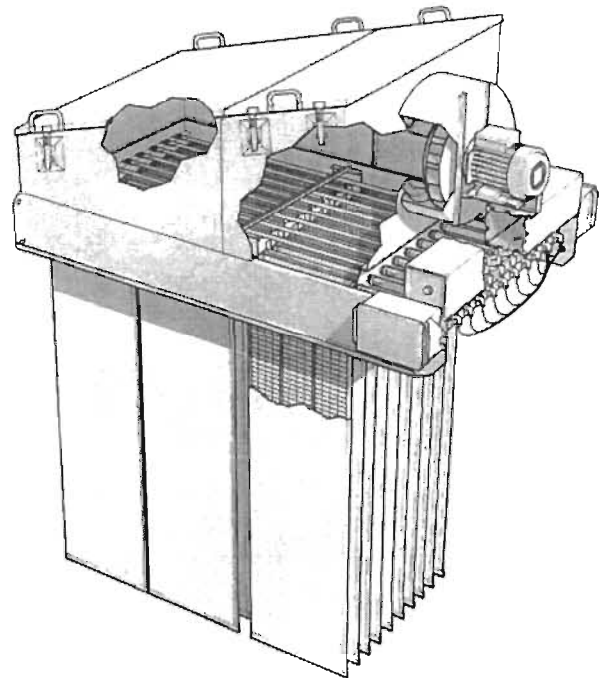
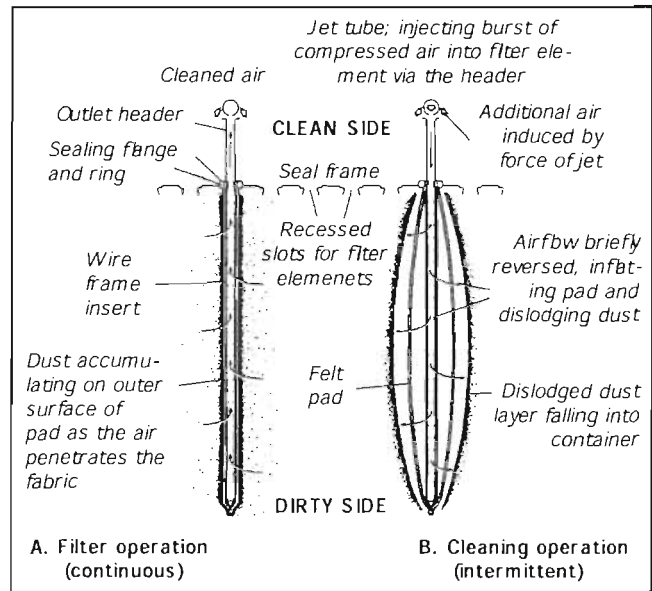

MARTIN ENGINEERING USA

One Martin Place
 Neponset IL 61345-9766 USA

800-544-2947 or 309-594-2384

FAX: 309-594-2432

www.martin-eng.com

QUALITY MANAGEMENT SYSTEM
 CERTIFIED BY DNV

ISO 9001:2000

Attachment I

Operation and Maintenance Plan

Operation and Maintenance Plan

The facility equipment will be operated and maintained in accordance with manufacturer's recommendations, operations and maintenance experience, and technical guidance taking into account protection of equipment, safety of personnel and other factors as deemed necessary to maintain compliance with the permitted limits.