

Department of
Environmental Protection
Division of Air Resource Management

**SUBMITTED APPLICATION REPORT
APPLICATION FOR AIR PERMIT - LONG FORM**

--- Form Effective 02/02/06 ---

Application Number: 1270- 2

Application Name: OKEECHOBEE AC & AV MODIFICATION
FOR FLARES: PSD

Date Submitted: 28 February 2007

I. APPLICATION INFORMATION

Air Construction Permit - Use this form to apply for any air construction permit at a facility operating under a federally enforceable state air operation permit (FESOP) or Title V air permit. Also use this form to apply for an air construction permit:

- For a proposed project subject to prevention of significant deterioration (PSD) review, nonattainment area (NAA) new source review, or maximum achievable control technology (MACT) review; or
- Where the applicant proposes to assume a restriction on the potential emissions of one or more pollutants to escape a federal program requirement such as PSD review, NAA new source review, Title V, or MACT; or
- Where the applicant proposes to establish, revise, or renew a plantwide applicability limit (PAL).

Air Operation Permit - Use this form to apply for:

- an initial federally enforceable state air operation permit (FESOP); or
- an initial/revised/renewal Title V air operation permit.

Air Construction Permit & Title V Air Operation Permit (Concurrent Processing Option) - Use this form to apply for both an air construction permit and a revised or renewal Title V air operation permit incorporating the proposed project.

To ensure accuracy, please see form instructions.

Identification of Facility

1. Facility Owner/Company Name: OKEECHOBEE LANDFILL, INC.	
2. Site Name: OKEECHOBEE LANDFILL	
3. Facility Identification Number: 0930104	
4. Facility Location...	
Street Address or Other Locator:	3.5 miles north of St. Rd. 70 on NE 128th Avenue
	10800 N.E. 128TH AVENUE
City: OKEECHOBEE	County: OKEECHOBEE Zip Code: 34972
5. Relocatable Facility? <input type="checkbox"/> Yes <input checked="" type="checkbox"/> No	6. Existing Title V Permitted Facility <input checked="" type="checkbox"/> Yes <input type="checkbox"/> No

Application Contact

1.	Application Contact Name: JOE FASULO	Application Contact Job Title: District Manager
2.	Application Contact Mailing Address... Organization/Firm: OKEECHOBEE LANDFILL, INC. Street Address: 10800 N.E. 128TH AVENUE City: OKEECHOBEE State: FL Zip Code: 34972	
3.	Application Contact Telephone Numbers... Telephone: (863) 357-0111 ext. Fax: (863) 357-0772	
4.	Application Contact Email Address: jfasulo@wm.com	

Purpose of Application**This application for air permit is submitted to obtain: (Check one)****Air Construction Permit**

- Air construction permit.
- Air construction permit to establish, revise, or renew a plantwide applicability limit (PAL).
- Air construction permit to establish, revise, or renew a plantwide applicability limit (PAL), and separate air construction permit to authorize construction or modification of one or more emissions units covered by the PAL.

Air Operation Permit

- Initial Title V air operation permit.
- Title V air operation permit revision.
- Title V air operation permit renewal.
- Initial federally enforceable state air operation permit (FESOP) where professional engineer (PE) certification is required.
- Initial federally enforceable state air operation permit (FESOP) where professional engineer (PE) certification is not required.

Air Construction Permit and Revised/Renewal Title V Air Operation Permit**(Concurrent Processing)**

- Air construction permit and Title V permit revision, incorporating the proposed project.
- Air construction permit and Title V permit renewal, incorporating the proposed project.

Note: By checking one of the above two boxes, you, the applicant, are requesting concurrent processing pursuant to Rule 62-213.405, F.A.C. In such case, you must also check the following box:

- I hereby request that the department waive the processing time requirements of the air construction permit to accommodate the processing time frames of the Title V air operation permit.

Application Comment

Application purpose: To continue construction of EU-001 a MSW landfill, its gas collection and control devices. This is a PSD Air Modification Construction Permit Application.

Scope of Application

Emissions Unit ID Number	Description of Emissions Unit	Air Permit Type
1	MSW Landfill with an active gas collection & control devices	AC1A
3	3000SCFM ENC FLARE-application redesignates a control device	ACM1
4	3000 SCFM OPEN FLARE-application redesignates a control dev.	ACM1
5	3000SCFM ENC FLARE-application redesignates a control device	ACM1

Note: The fee calculation information associated with this application may be accessed from the Main Menu of ESPAP.

Owner/Authorized Representative Statement**Complete if applying for an air construction permit or an initial FESOP.**

1. Owner/Authorized Representative Name: JOHN VAN GESSEL
 Owner/Authorized Representative Job Title: Vice President AND Assistant Secretary

2. Owner/Authorized Representative Mailing Address...
 Organization/Firm: WASTE MANAGEMENT, INC. OF FLORIDA
 Street Address: 2859 WEST PACES FERRY ROAD
 SUITE 1600
 City: ATLANTA State: GA Zip Code: 30339

3. Owner/Authorized Representative Telephone Numbers...
 Telephone: (770) 805-3350 ext. Fax: (770) 805-8485

4. Owner/Authorized Representative Email Address: jvangessel@wm.com

5. Owner/Authorized Representative Statement:
 By entering my PIN below, I certify that I am the owner/authorized representative of the facility addressed in this air permit application. I hereby certify, based on information and belief formed after reasonable inquiry, that the statements made in this application are true, accurate and complete and that, to the best of my knowledge, any estimates of emissions reported in this application are based upon reasonable techniques for calculating emissions. The air pollutant emissions units and air pollution control equipment described in this application will be operated and maintained so as to comply with all applicable standards for control of air pollutant emissions found in the statutes of the State of Florida and rules of the Department of Environmental Protection and revisions thereof and all other requirements identified in this application to which the facility is subject. I understand that a permit, if granted by the department, cannot be transferred without authorization from the department, and I will promptly notify the department upon sale or legal transfer of the facility or any permitted emissions unit.

Application Responsible Official Certification

1.	Application Responsible Official Name: MIKE STALLARD
2.	Application Responsible Official Qualification (Check one or more of the following options, as applicable): <input checked="" type="checkbox"/> For a corporation, the president, secretary, treasurer, or vice-president of the corporation in charge of a principal business function, or any other person who performs similar policy or decision-making functions for the corporation, or a duly authorized representative of such person if the representative is responsible for the overall operation of one or more manufacturing, production, or operating facilities applying for or subject to a permit under Chapter 62-213, F.A.C. <input type="checkbox"/> For a partnership or sole proprietorship, a general partner or the proprietor, respectively. <input type="checkbox"/> For a municipality, county, state, federal, or other public agency, either a principal executive officer or ranking elected official. <input type="checkbox"/> The designated representative at an Acid Rain source.
3.	Application Responsible Official Mailing Address... Organization/Firm: WASTE MANAGEMENT INC. OF FLORIDA Street Address: 10800 NE 128TH AVENUE City: OKEECHOBEE State: FL Zip Code: 34972
4.	Application Responsible Official Telephone Numbers... Telephone: (863)357-0111 ext. 221 Fax: (863)357-0772
5.	Application Responsible Official Email Address: mstallard@wm.com

Professional Engineer Certification

1.	Professional Engineer Name: KRISTIN ALZHEIMER Registration Number: 43456	Professional Engineer Job Title: Engineering Manager
2.	Professional Engineer Mailing Address... Organization/Firm: SHAW ENVIRONMENTAL INC. Street Address: 200 HORIZON CENTER BOULEVARD City: TRENTON State: NJ Zip Code: 08691	
3.	Professional Engineer Telephone Numbers... Telephone: (609) 584-6873 ext. Fax: (609) 584-6873	
4.	Professional Engineer Email Address: KRISTIN.ALZHEIMER@SHAWGRP.COM	
5.	Professional Engineer Statement: I hereby certify, except as particularly noted herein*, that: (1) To the best of my knowledge, there is reasonable assurance that the air pollutant emissions unit(s) and the air pollution control equipment described in this application for air permit, when properly operated and maintained, will comply with all applicable standards for control of air pollutant emissions found in the Florida Statutes and rules of the Department of Environmental Protection; and (2) To the best of my knowledge, any emission estimates reported or relied on in this application are true, accurate, and complete and are either based upon reasonable techniques available for calculating emissions or, for emission estimates of hazardous air pollutants not regulated for an emissions unit addressed in this application, based solely upon the materials, information and calculations submitted with this application. (3) If the purpose of this application is to obtain a Title V air operation permit (check here <input type="checkbox"/> , if so), I further certify that each emissions unit described in this application for air permit, when properly operated and maintained, will comply with the applicable requirements identified in this application to which the unit is subject, except those emissions units for which a compliance plan and schedule is submitted with this application. (4) If the purpose of this application is to obtain an air construction permit (check here <input type="checkbox"/> , if so) or concurrently process and obtain an air construction permit and a Title V air operation permit revision or renewal for one or more proposed new or modified emissions units (check here <input type="checkbox"/> , if so), I further certify that the engineering features of each such emissions unit described in this application have been designed or examined by me or individuals under my direct supervision and found to be in conformity with sound engineering principles applicable to the control of emissions of the air pollutants characterized in this application. (5) If the purpose of this application is to obtain an initial air operation permit or operation permit revision or renewal for one or more newly constructed or modified emissions units (check here <input type="checkbox"/> , if so), I further certify that, with the exception of any changes detailed as part of this application, each such emissions unit has been constructed or modified in substantial accordance with the information given in the corresponding application for air construction permit and with all provisions contained in such permit.	

* Explain any exception to the certification statement.

Professional Engineer Exception Statement:

II. FACILITY INFORMATION

A. GENERAL FACILITY INFORMATION

Facility Location and Type

1. Facility UTM Coordinates... Zone 17 East (km) 530.28 North (km) 3023.96	2. Facility Latitude/Longitude... Latitude (DD/MM/SS) 27° 20' 24" N Longitude (DD/MM/SS) 80° 41' 27" W		
3. Governmental Facility Code: (0) NOT OWNED OR OPERATED BY A FEDERAL, STATE, OR LOCAL GOVERNMENT	4. Facility Status Code: Active	5. Facility Major Group SIC Code: (49) ELECTRIC, GAS AND SANITARY SERVICES	6. Facility SIC(s): Primary: 4953 Secondary: 4911
7. Facility Comment:			

Facility Contact

1. Facility Contact Name: MIKE STALLARD	Facility Contact Job Title: LANDFILL DIRECTOR
2. Facility Contact Mailing Address... Organization/Firm: OKEECHOBEE LANDFILL, INC. Street Address: 10800 NE 128TH AVENUE <div style="display: flex; justify-content: space-between;"> City: OKEECHOBEE State: FL Zip Code: 34972 </div>	
3. Facility Contact Telephone Numbers... Telephone: (863) 357-0111 ext. Fax: (863) 357-0772	
4. Facility Contact Email Address:	

Facility Primary Responsible Official

Complete if an "application responsible official" is identified in Section I. that is not the facility "primary responsible official."

1. Facility Primary Responsible Official Name: MIKE STALLARD	Facility Primary Responsible Official Job Title: Director, Landfill Operations
2. Facility Primary Responsible Official Mailing Address... Organization/Firm: WASTE MANAGEMENT INC. OF FLORIDA Street Address: 10800 NE 128TH AVENUE <div style="display: flex; justify-content: space-between;"> City: OKEECHOBEE State: FL Zip Code: 34972 </div>	
3. Facility Primary Responsible Official Telephone Numbers... Telephone: (863) 357-0111 ext. 221 Fax: (863) 357-0772	
4. Facility Primary Responsible Official Email Address: mstallard@wm.com	

Facility Regulatory Classifications Check all that would apply *following* completion of all projects and implementation of all other changes proposed in this application for air permit. Refer to instructions to distinguish between a "major source" and a "synthetic minor source."

1.	<input type="checkbox"/> Small Business Stationary Source	<input type="checkbox"/> Unknown
2.	<input type="checkbox"/> Synthetic Non-Title V Source	
3.	<input checked="" type="checkbox"/> Title V Source	
4.	<input checked="" type="checkbox"/> Major Source of Air Pollutants, Other than Hazardous Air Pollutants (HAPs)	
5.	<input type="checkbox"/> Synthetic Minor Source of Air Pollutants, Other than HAPs	
6.	<input checked="" type="checkbox"/> Major Source of Hazardous Air Pollutants (HAPs)	
7.	<input type="checkbox"/> Synthetic Minor Source of HAPs	
8.	<input checked="" type="checkbox"/> One or More Emissions Units Subject to NSPS (40 CFR Part 60)	
9.	<input type="checkbox"/> One or More Emissions Units Subject to Emission Guidelines (40 CFR Part 60)	
10.	<input checked="" type="checkbox"/> One or More Emissions Units Subject to NESHAP (40 CFR Part 61 or Part 63)	
11.	<input type="checkbox"/> Title V Source Solely by EPA Designation (40 CFR 70.3(a)(5))	
12.	Facility Regulatory Classifications Comment:	

List of Pollutants Emitted by Facility

1. Pollutants Emitted	2. Pollutant Classification	Emissions Cap [Y or N]?
PM10	(A) ACTUAL OR POTENTIAL EMISSIONS ARE ABOVE THE APPLICABLE MAJOR SOURCE THRESHOLDS.	N
PM	(A) ACTUAL OR POTENTIAL EMISSIONS ARE ABOVE THE APPLICABLE MAJOR SOURCE THRESHOLDS.	N
HAPS	(A) ACTUAL OR POTENTIAL EMISSIONS ARE ABOVE THE APPLICABLE MAJOR SOURCE THRESHOLDS.	N
CO	(A) ACTUAL OR POTENTIAL EMISSIONS ARE ABOVE THE APPLICABLE MAJOR SOURCE THRESHOLDS.	N
NOX	(A) ACTUAL OR POTENTIAL EMISSIONS ARE ABOVE THE APPLICABLE MAJOR SOURCE THRESHOLDS.	N
NMOC	(B) ACTUAL AND POTENTIAL EMISSIONS BELOW ALL APPLICABLE MAJOR SOURCE THRESHOLDS	N
VOC	(C) CLASS IS UNKNOWN	N
SO2	()	N

B. Emissions Caps

Facility-Wide or Multi-Unit Emissions Caps

1. Pollutant Subject to Emissions Cap	2. Facility Wide Cap [Y or N]? (all units)	3. Emissions Unit ID No.s Under Cap (if not all units)	4. Hourly Cap (lb/hr)	5. Annual Cap (ton/yr)	6. Basis for Emissions Cap
NOX	No	No EUs included in the cap			OTHER
VOC	No	No EUs included in the cap			OTHER
NMOC	No	No EUs included in the cap			OTHER
<p>7. Facility-Wide or Multi-Unit Emissions Cap Comment: NOX: State, not federal, threshold for major facility (Title V). Greater than 100 TPY. F.A.C. 62.213-420(3)(c) VOC: MSW Landfill NSPS - 40 CFR 60, Subpart WWW NMOC: MSW Landfill NSPS - 40 CFR 60, Subpart WWW</p>					

C. FACILITY ADDITIONAL INFORMATION**Additional Requirements for All Applications, Except as Otherwise Stated**

1. Facility Plot Plan: (Required for all permit applications, except Title V air operation permit revision applications if this information was submitted to the department within the previous five years and would not be altered as a result of the revision being sought)	<input type="checkbox"/> Applicable	<input checked="" type="checkbox"/> Previously Submitted, Date: 26-MAR-03	<input checked="" type="checkbox"/> Attachment
2. Process Flow Diagram(s): (Required for all permit applications, except Title V air operation permit revision applications if this information was submitted to the department within the previous five years and would not be altered as a result of the revision being sought)	<input type="checkbox"/> Applicable	<input type="checkbox"/> Previously Submitted, Date:	<input checked="" type="checkbox"/> Attachment
3. Precautions to Prevent Emissions of Unconfined Particulate Matter: (Required for all permit applications, except Title V air operation permit revision applications if this information was submitted to the department within the previous five years and would not be altered as a result of the revision being sought)	<input type="checkbox"/> Applicable	<input checked="" type="checkbox"/> Previously Submitted, Date:	<input checked="" type="checkbox"/> Attachment

Additional Requirements for Air Construction Permit Applications

1. Area Map Showing Facility Location: (Not applicable for existing permitted facility)	<input checked="" type="checkbox"/> Applicable	<input checked="" type="checkbox"/> Attachment
2. Description of Proposed Construction, Modification, or Plantwide Applicability Limit (PAL):	<input checked="" type="checkbox"/> Applicable	<input checked="" type="checkbox"/> Attachment
3. Rule Applicability Analysis:	<input checked="" type="checkbox"/> Applicable	<input checked="" type="checkbox"/> Attachment
4. List of Exempt Emissions Units (Rule 62-210.300(3), F.A.C.): (Not applicable if no exempt units at facility)	<input type="checkbox"/> Applicable	<input type="checkbox"/> Attachment
5. Fugitive Emissions Identification:	<input type="checkbox"/> Applicable	<input type="checkbox"/> Attachment
6. Air Quality Analysis (Rule 62-212.400(7), F.A.C.):	<input checked="" type="checkbox"/> Applicable	<input checked="" type="checkbox"/> Attachment
7. Source Impact Analysis (Rule 62-212.400(5), F.A.C.):	<input checked="" type="checkbox"/> Applicable	<input checked="" type="checkbox"/> Attachment
8. Air Quality Impact since 1977 (Rule 62-212.400(4)(e), F.A.C.):	<input checked="" type="checkbox"/> Applicable	<input checked="" type="checkbox"/> Attachment
9. Additional Impact Analyses (Rules 62-212.400(8) and 62-212.500(4)(e), F.A.C.):	<input checked="" type="checkbox"/> Applicable	<input checked="" type="checkbox"/> Attachment
10. Alternative Analysis Requirement (Rule 62-212.500(4)(g), F.A.C.):	<input type="checkbox"/> Applicable	<input type="checkbox"/> Attachment

Additional Requirements for FESOP Applications

1. List of Exempt Emissions Units (Rule 62-210.300(3)(a) or (b)1., F.A.C.): (Not applicable if no exempt units at facility)	<input type="checkbox"/> Applicable	<input type="checkbox"/> Attachment
---	-------------------------------------	-------------------------------------

Additional Requirements for Title V Air Operation Permit Applications

1. List of Insignificant Activities: (Required for initial/renewal applications, but not for revision applications)	<input type="checkbox"/> Applicable	<input type="checkbox"/> Attachment
2. Identification of Applicable Requirements (Required for initial/renewal applications, and for revision applications if this information would be changed as a result of the revision being sought):	<input type="checkbox"/> Applicable	<input type="checkbox"/> Attachment
3. Compliance Report and Plan: (Required for all initial/revision/renewal applications): Note: A compliance plan must be submitted for each emissions unit that is not in compliance with all applicable requirements at the time of application and/or at any time during application processing. The department must be notified of any changes in compliance status during application processing.	<input type="checkbox"/> Applicable	<input type="checkbox"/> Attachment
4. List of Equipment/Activities Regulated under Title VI (If applicable, required for initial/renewal applications only):	<input type="checkbox"/> Applicable <input type="checkbox"/> Equipment/Activities On site but Not Required to be Individually Listed	<input type="checkbox"/> Attachment
5. Verification of Risk Management Plan Submission to EPA (If applicable, required for initial/renewal applications only):	<input type="checkbox"/> Applicable	<input type="checkbox"/> Attachment
6. Requested Changes to Current Title V Air Operation Permit:	<input type="checkbox"/> Applicable	<input type="checkbox"/> Attachment

Other Information Regarding this Facility:

4. Other Facility Information:	<input checked="" type="checkbox"/> Included	<input checked="" type="checkbox"/> Attachment
--------------------------------	--	--

Additional Requirements Comment

Attached are the cover letter, title pages, table of contents, and PSD/AC Permit Application 1270-2 Support Documentation.
--

Facility Attachments

Supplemental Item	Electronic File Name	Attachment Description	Electronic Document	Date Uploaded
Area Map Showing Facility Location	Figure 1 - Facility Area Map.pdf	Figure 1 - Facility Area Map	Yes	02/28/2007
Description of Proposed Construction, Modification or Plantwide Applicability Limit (PAL)	Description of proposed.doc	Please refer to Section 3.0 of the PSD Permit Application Support Documentation	Yes	02/28/2007
Rule Applicability Analysis	Rule Applicability Analysis.doc	Please refer to section 4.0 of the PSD Permit Application Support Documentation	Yes	02/28/2007
Air Quality Analysis	Air Qual Analysis.doc	Please refer to Section 4.2 of the Air Quality Impact Assessment	Yes	02/28/2007
Source Impact Analysis	Air Quality Impact Analysis_OKI draft 02-26-2007ver01 resized.pdf	Section III - Air Quality Impact Assessment	Yes	02/28/2007
Air Quality Impact since 1977	Air Qual 1977.doc	Please refer to Section 5.2 of Section III - Air Quality Impact Assessment	Yes	02/28/2007
Additional Impact Analyses	Additional Impact Analysis.doc	Please refer to Section 5.0 of the Air Quality Impact Assessment	Yes	02/28/2007
Facility Plot Plan	Figure 3 - Facility Plot Plan.pdf	Figure 3 - Plot Plan	Yes	02/28/2007
Process Flow Diagram (s)	Figure 2 - Process Flow Diagram.pdf	Figure 2 - Process Flow Diagram	Yes	02/28/2007
Precautions to Prevent Emissions of Unconfined Particulate Matter	Precautions to Prevent.doc	Please refer to Section 6.0 of the PSD Permit Application Support Documentation	Yes	02/28/2007
Other Facility Information	Air Construction PSD 02272007A.pdf	Cover Letter	Yes	02/28/2007
	TOC whole application + covers.pdf	Title Page/TOC	Yes	02/28/2007
	Final AC-PSD Report 2007-02-27.pdf	PSD/AC Permit Application Support Documentation	Yes	02/28/2007

**III. EMISSIONS UNIT INFORMATION
A. GENERAL EMISSIONS UNIT INFORMATION**

Title V Air Operation Permit Emissions Unit Classification

<p>1. (Check one, if applying for an initial, revised or renewal Title V air operation permit. Skip this item if applying for an air construction permit or FESOP only.)</p> <p><input checked="" type="checkbox"/> The emissions unit addressed in this Emissions Unit Information Section is a regulated emissions unit.</p> <p><input type="checkbox"/> The emissions unit addressed in this Emissions Unit Information Section is an unregulated emissions unit.</p>
--

Emissions Unit Description and Status

<p>1. Type of Emissions Unit Addressed in this Section: (Check one)</p> <p><input checked="" type="checkbox"/> This Emissions Unit Information Section addresses, as a single emissions unit, a single process or production unit, or activity, which produces one or more air pollutants and which has at least one definable emission point (stack or vent).</p> <p><input type="checkbox"/> This Emissions Unit Information Section addresses, as a single emissions unit, a group of process or production units and activities which has at least one definable emission point (stack or vent) but may also produce fugitive emissions.</p> <p><input type="checkbox"/> This Emissions Unit Information Section addresses, as a single emissions unit, one or more process or production units and activities which produce fugitive emissions only.</p>				
<p>2. Description of Emissions Unit Addressed in this Section: MSW Landfill with an active gas collection & control devices</p>				
<p>3. Emissions Unit Identification Number: 1</p>				
<p>4. Emissions Unit Status Code: A</p>	<p>5. Commence Construction Date:</p>	<p>6. Initial Startup Date: 01-JAN-81</p>	<p>7. Emissions Unit Major Group SIC Code: 49</p>	<p>8. Acid Rain Unit? <input type="checkbox"/> Yes <input checked="" type="checkbox"/> No</p>
<p>9. Package Unit NOT RELEVANT</p>		<p>Model Number: NA</p>		
<p>10. Generator Nameplate Rating: MW</p>				
<p>11. Emissions Unit Comment: Proposed typical operating scenario includes LFG turbines as the control device and flares as the secondary control scenario.</p>				

Emissions Unit Control Equipment

Code	Equipment	Description
0	NO CONTROL EQUIPMENT	Fugitive emission from the landfill
23	FLARING	Modification: 8 additional LFG utility (open) flares to be intalled as LFG generation increases.
13	GAS SCRUBBER, GENERAL	LFG desulfurization system
99	MISCELLANEOUS CONTROL DEVICES	LFG Turbines

B. EMISSIONS UNIT CAPACITY INFORMATION

(Optional for unregulated emissions units.)

Emissions Unit Operating Capacity and Schedule

1. Maximum Process or Throughput Rate: 32400 SCFM		
2. Maximum Production Rate:		
3. Maximum Heat Input Rate: million Btu/hr		
4. Maximum Incineration Rate:	pounds/hr	
	tons/day	
5. Requested Maximum Operating Schedule:		
	24 hours/day	7 days/week
	52 weeks/year	8760 hours/year
6. Operating Capacity/Schedule Comment:		
The EU's operating hours are not consistent with LFG generation which is always occurring.		

C. EMISSION POINT (STACK/VENT) INFORMATION

(Optional for unregulated emissions units.)

Emission Point Description and Type

<p>1. Identification of Point on Plot Plan or Flow Diagram: 4 - Turbine (Representative stack information)</p>	<p>2. Emission Point Type Code: 3 - A configuration of multiple emissions points serving a single emissions unit</p>	
<p>3. Descriptions of Emission Points Comprising this Emissions Unit for VE Tracking:</p> <ul style="list-style-type: none"> • Control Device 1: Existing Enclosed LFG Flare (permit redesignates this EU as a control device) • Control Device 2: Existing Enclosed LFG Flare (permit redesignates this EU as a control device) • Control Device 3: Existing Utility Flare (permit redesignates this EU as a control device) • Control Device 5: Utility Flare (proposed) • Control Device 7: Utility Flare (proposed) • Control Device 9: Utility Flare (proposed) • Control Device 11: LFG Turbine (proposed) • Control Device 13: LFG Turbine (proposed) • Control Device 15: LFG Turbine (proposed) • Control Device 17: LFG Turbine (proposed) • Control Device 16: LFG Turbine (proposed) • Control Device 14: LFG Turbine (proposed) • Control Device 12: LFG Turbine (proposed) • Control Device 10: Utility Flare (proposed) • Control Device 8: Utility Flare (proposed) • Control Device 6: Utility Flare (proposed) • Control Device 4: Utility Flare (existing odor control) 		
<p>4. ID Numbers or Descriptions of Emission Units with this Emission Point in Common:</p>		
<p>5. Discharge Type Code: (V) A STACK WITH AN UNOBSTRUCTED OPENING DISCHARGING IN A VERTICAL/NEARLY VERTICAL DIRECTION</p>	<p>6. Stack Height: 50 feet</p>	<p>7. Exit Diameter: 8.33 feet</p>
<p>8. Exit Temperature: 778° F</p>	<p>9. Actual Volumetric Flow Rate: 193751 acfm</p>	<p>10. Water Vapor: 8 %</p>
<p>11. Maximum Dry Standard Flow Rate: 3680 dscfm</p>	<p>12. Nonstack Emission Point Height: feet</p>	
<p>13. Emission Point UTM Coordinates... Zone: East (km): North (km):</p>	<p>14. Emission Point Latitude/Longitude... Latitude: Longitude:</p>	
<p>15. Emission Point Comment: Stack information for the multiple points is summarized in Appendix H</p>		

D. SEGMENT (PROCESS/FUEL) INFORMATION

Segment Description and Rate: Segment 1 of 4

1. Segment Description (Process/Fuel Type): Landfill Operations		
2. Source Classification Code (SCC): 50100402	3. SCC Units: Acre-Years Landfill Existing	
4. Maximum Hourly Rate:	5. Maximum Annual Rate:	6. Estimated Annual Activity Factor:
7. Maximum % Sulfur:	8. Maximum % Ash:	9. Million Btu per SCC Unit:
10. Segment Comment:		
Is this a valid segment? No		

Segment Description and Rate: Segment 2 of 4

1. Segment Description (Process/Fuel Type): LFG Generation - Gas collection		
2. Source Classification Code (SCC): 50100406	3. SCC Units: Million Cubic Feet Waste Gas Processed	
4. Maximum Hourly Rate: 1.944	5. Maximum Annual Rate: 17030	6. Estimated Annual Activity Factor:
7. Maximum % Sulfur: .6	8. Maximum % Ash:	9. Million Btu per SCC Unit:
10. Segment Comment: LFG generation is estimated based on waste deposition rate		
Is this a valid segment? Yes		

Segment Description and Rate: Segment 3 of 4

1. Segment Description (Process/Fuel Type): LFG Flaring		
2. Source Classification Code (SCC): 50100410	3. SCC Units: Million Cubic Feet Waste Gas Burned	
4. Maximum Hourly Rate: 1.944	5. Maximum Annual Rate: 17030	6. Estimated Annual Activity Factor:
7. Maximum % Sulfur: .04	8. Maximum % Ash:	9. Million Btu per SCC Unit: 972
10. Segment Comment: Sulfur content for the destructive control devices is Post-BACT (LFG desulfurization)		
Is this a valid segment? No		

Segment Description and Rate: Segment 4 of 4

1. Segment Description (Process/Fuel Type): Waste Gas Recovery: Turbines		
2. Source Classification Code (SCC): 50100420	3. SCC Units: Million Cubic Feet Waste Gas Burned	
4. Maximum Hourly Rate: 1.944	5. Maximum Annual Rate: 17030	6. Estimated Annual Activity Factor:
7. Maximum % Sulfur: .04	8. Maximum % Ash:	9. Million Btu per SCC Unit: 972
10. Segment Comment: Sulfur content for the destructive control devices is Post-BACT (LFG desulfurization)		
Is this a valid segment? No		

E. EMISSIONS UNIT POLLUTANTS**List of Pollutants Emitted by Emissions Unit**

1. Pollutant Emitted	2. Primary Control Device Code	3. Secondary Control Device Code	4. Pollutant Regulatory Code	Valid?
CO	NO CONTROL EQUIPMENT		NS	Yes
HAPS	MISCELLANEOUS CONTROL DEVICES	FLARING	WP	Yes
NMOC	MISCELLANEOUS CONTROL DEVICES	FLARING	EL	Yes
NOX	NO CONTROL EQUIPMENT		NS	Yes
PM10	NO CONTROL EQUIPMENT		NS	Yes
SO2	GAS SCRUBBER, GENERAL		WP	Yes
VOC	FLARING		NS	Yes

**F1. EMISSIONS UNIT POLLUTANT DETAIL INFORMATION -
POTENTIAL, FUGITIVE, AND ACTUAL EMISSIONS**

(Optional for unregulated emissions units.)

Potential, Estimated Fugitive, and Baseline & Projected Actual Emissions

Complete for each pollutant identified in Subsection E if applying for an air construction permit or concurrent processing of an air construction permit and a revised or renewal Title V permit. Complete for each emissions-limited pollutant identified in Subsection E if applying for an air operation permit.

1. Pollutant Emitted: CO - Carbon Monoxide		2. Total Percent Efficiency of Control:	
3. Potential Emissions: 329.5 lb/hour 1442 tons/year		4. Synthetically Limited? <input type="checkbox"/> Yes <input checked="" type="checkbox"/> No	
5. Range of Estimated Fugitive Emissions (as applicable): to tons/year			
6. Emission Factor: LB/MMBTU Reference: AP-42 13.5-1		7. Emissions Method Code: (3) CALCULATED USING EMISSION FACTOR FROM AP-42/FIRE SYSTEM.	
8.a. Baseline Actual Emissions (if required): 121 tons/year		8.b. Baseline 24-month Period: From: 01-FEB-05 To: 01-FEB-07	
9.a. Projected Actual Emissions (if required): tons/year		9.b. Projected Monitoring Period: <input type="checkbox"/> 5 years <input type="checkbox"/> 10 years	
10. Calculation of Emissions: See Appendix B Support Calculations. The emission rate for this pollutant is based on 10 LFG flares.			
11. Pollutant Potential,Fugitive, and Actual Emissions Comment: This pollutant is a product of the destructive control devices for NMOC and HAPs: turbines and flaring			

**F2. EMISSIONS UNIT POLLUTANT DETAIL INFORMATION -
ALLOWABLE EMISSIONS**

Complete if the pollutant identified in Subsection F1 is or would be subject to a numerical emissions limitation.

No Pollutant Allowable Emissions information submitted.

**F1. EMISSIONS UNIT POLLUTANT DETAIL INFORMATION -
POTENTIAL, FUGITIVE, AND ACTUAL EMISSIONS****(Optional for unregulated emissions units.)****Potential, Estimated Fugitive, and Baseline & Projected Actual Emissions****Complete for each pollutant identified in Subsection E if applying for an air construction permit or concurrent processing of an air construction permit and a revised or renewal Title V permit.****Complete for each emissions-limited pollutant identified in Subsection E if applying for an air operation permit.**

1. Pollutant Emitted: HAPS - Total Hazardous Air Pollutants	2. Total Percent Efficiency of Control: 98
3. Potential Emissions: 9 lb/hour 40 tons/year	4. Synthetically Limited? <input type="checkbox"/> Yes <input checked="" type="checkbox"/> No
5. Range of Estimated Fugitive Emissions (as applicable): to tons/year	
6. Emission Factor: PPMVD Reference: 2.4-1	7. Emissions Method Code: (3) CALCULATED USING EMISSION FACTOR FROM AP-42/FIRE SYSTEM.
8.a. Baseline Actual Emissions (if required): 5.7 tons/year	8.b. Baseline 24-month Period: From: 01-FEB-05 To: 01-FEB-07
9.a. Projected Actual Emissions (if required): tons/year	9.b. Projected Monitoring Period: <input type="checkbox"/> 5 years <input type="checkbox"/> 10 years
10. Calculation of Emissions: See Appendix B Support Calculations. The emission rate for this pollutant is based on 98% control efficiency through 10 LFG flares, 7 turbines and 2 LFG flares, or a combination of flares and turbines based on 32,400 scfm.	
11. Pollutant Potential, Fugitive, and Actual Emissions Comment:	

**F2. EMISSIONS UNIT POLLUTANT DETAIL INFORMATION -
ALLOWABLE EMISSIONS**

Complete if the pollutant identified in Subsection F1 is or would be subject to a numerical emissions limitation.

No Pollutant Allowable Emissions information submitted.

**F1. EMISSIONS UNIT POLLUTANT DETAIL INFORMATION -
POTENTIAL, FUGITIVE, AND ACTUAL EMISSIONS****(Optional for unregulated emissions units.)****Potential, Estimated Fugitive, and Baseline & Projected Actual Emissions**

Complete for each pollutant identified in Subsection E if applying for an air construction permit or concurrent processing of an air construction permit and a revised or renewal Title V permit. Complete for each emissions-limited pollutant identified in Subsection E if applying for an air operation permit.

1. Pollutant Emitted: NMOC - Nonmethane Organic Compounds from MSW Landfill		2. Total Percent Efficiency of Control: 98	
3. Potential Emissions: 5.3 lb/hour 23 tons/year		4. Synthetically Limited? <input type="checkbox"/> Yes <input checked="" type="checkbox"/> No	
5. Range of Estimated Fugitive Emissions (as applicable): to tons/year			
6. Emission Factor: 595 PPMVD Reference: AP-42 TABLE 2.4-2		7. Emissions Method Code: (3) CALCULATED USING EMISSION FACTOR FROM AP- 42/FIRE SYSTEM.	
8.a. Baseline Actual Emissions (if required): 3.4 tons/year		8.b. Baseline 24-month Period: From: 01-FEB-05 To: 01-FEB-07	
9.a. Projected Actual Emissions (if required): tons/year		9.b. Projected Monitoring Period: <input type="checkbox"/> 5 years <input type="checkbox"/> 10 years	
10. Calculation of Emissions: See Appendix B Support Calculations. The emission rate for this pollutant is based on 98% control efficiency through 10 LFG flares, 7 turbines and 2 LFG flares, or a combination of flares and turbines based on 32,400 scfm.			
11. Pollutant Potential, Fugitive, and Actual Emissions Comment:			

**F2. EMISSIONS UNIT POLLUTANT DETAIL INFORMATION -
ALLOWABLE EMISSIONS**

Complete if the pollutant identified in Subsection F1 is or would be subject to a numerical emissions limitation.

No Pollutant Allowable Emissions information submitted.

F1. EMISSIONS UNIT POLLUTANT DETAIL INFORMATION - POTENTIAL, FUGITIVE, AND ACTUAL EMISSIONS

(Optional for unregulated emissions units.)

Potential, Estimated Fugitive, and Baseline & Projected Actual Emissions

Complete for each pollutant identified in Subsection E if applying for an air construction permit or concurrent processing of an air construction permit and a revised or renewal Title V permit. Complete for each emissions-limited pollutant identified in Subsection E if applying for an air operation permit.

1. Pollutant Emitted: NOX - Nitrogen Oxides	2. Total Percent Efficiency of Control:
3. Potential Emissions: 227 lb/hour 992 tons/year	4. Synthetically Limited? <input type="checkbox"/> Yes <input checked="" type="checkbox"/> No
5. Range of Estimated Fugitive Emissions (as applicable): to tons/year	
6. Emission Factor: 60 PPMVD @ 15% O2 Reference: MANUFACTURER: SOLAR	7. Emissions Method Code: (2) CALCULATED BY USE OF MATERIAL BALANCE AND KNOWLEDGE OF THE PROCESS.
8.a. Baseline Actual Emissions (if required): 34 tons/year	8.b. Baseline 24-month Period: From: 01-FEB-05 To: 01-FEB-07
9.a. Projected Actual Emissions (if required): tons/year	9.b. Projected Monitoring Period: <input type="checkbox"/> 5 years <input type="checkbox"/> 10 years
10. Calculation of Emissions: See Appendix B Support Calculations. The emission rate for this pollutant is based maximum potential to emit for 7 turbines and 2 LFG flares.	
11. Pollutant Potential, Fugitive, and Actual Emissions Comment: This pollutant is a product of the destructive control devices for NMOC and HAPs: turbines and flaring	

**F2. EMISSIONS UNIT POLLUTANT DETAIL INFORMATION -
ALLOWABLE EMISSIONS**

Complete if the pollutant identified in Subsection F1 is or would be subject to a numerical emissions limitation.

No Pollutant Allowable Emissions information submitted.

**F1. EMISSIONS UNIT POLLUTANT DETAIL INFORMATION -
POTENTIAL, FUGITIVE, AND ACTUAL EMISSIONS**

(Optional for unregulated emissions units.)

Potential, Estimated Fugitive, and Baseline & Projected Actual Emissions

Complete for each pollutant identified in Subsection E if applying for an air construction permit or concurrent processing of an air construction permit and a revised or renewal Title V permit. Complete for each emissions-limited pollutant identified in Subsection E if applying for an air operation permit.

1. Pollutant Emitted: PM10 - Particulate Matter - PM10		2. Total Percent Efficiency of Control:	
3. Potential Emissions: 18 lb/hour		77 tons/year	4. Synthetically Limited? <input type="checkbox"/> Yes <input checked="" type="checkbox"/> No
5. Range of Estimated Fugitive Emissions (as applicable): to tons/year			
6. Emission Factor: .023 LB/MMBTU Reference: 3.1-2B & 2.4-5		7. Emissions Method Code: (3) CALCULATED USING EMISSION FACTOR FROM AP-42/FIRE SYSTEM.	
8.a. Baseline Actual Emissions (if required): 9 tons/year		8.b. Baseline 24-month Period: From: 01-FEB-05 To: 01-FEB-07	
9.a. Projected Actual Emissions (if required): tons/year		9.b. Projected Monitoring Period: <input type="checkbox"/> 5 years <input type="checkbox"/> 10 years	
10. Calculation of Emissions: See Appendix B Support Calculations. The emission rate for this pollutant is based maximum potential to emit for 7 turbines and 2 LFG flares.			
11. Pollutant Potential, Fugitive, and Actual Emissions Comment: This pollutant is a product of the destructive control devices for NMOC and HAPs: turbines and flaring			

**F2. EMISSIONS UNIT POLLUTANT DETAIL INFORMATION -
ALLOWABLE EMISSIONS**

Complete if the pollutant identified in Subsection F1 is or would be subject to a numerical emissions limitation.

No Pollutant Allowable Emissions information submitted.

**F1. EMISSIONS UNIT POLLUTANT DETAIL INFORMATION -
POTENTIAL, FUGITIVE, AND ACTUAL EMISSIONS**

(Optional for unregulated emissions units.)

Potential, Estimated Fugitive, and Baseline & Projected Actual Emissions

Complete for each pollutant identified in Subsection E if applying for an air construction permit or concurrent processing of an air construction permit and a revised or renewal Title V permit. Complete for each emissions-limited pollutant identified in Subsection E if applying for an air operation permit.

1. Pollutant Emitted: SO2 - Sulfur Dioxide		2. Total Percent Efficiency of Control: 93	
3. Potential Emissions: 131 lb/hour		575 tons/year	4. Synthetically Limited? <input type="checkbox"/> Yes <input checked="" type="checkbox"/> No
5. Range of Estimated Fugitive Emissions (as applicable): to tons/year			
6. Emission Factor: 400 PPMVD Reference:		7. Emissions Method Code: (2) CALCULATED BY USE OF MATERIAL BALANCE AND KNOWLEDGE OF THE PROCESS.	
8.a. Baseline Actual Emissions (if required): 1209 tons/year		8.b. Baseline 24-month Period: From: 01-FEB-05 To: 01-FEB-07	
9.a. Projected Actual Emissions (if required): tons/year		9.b. Projected Monitoring Period: <input type="checkbox"/> 5 years <input type="checkbox"/> 10 years	
10. Calculation of Emissions: See Appendix B Support Calculations. The emission rate for this pollutant is based on 98% control efficiency through 10 LFG flares, 7 turbines and 2 LFG flares, or a combination of flares and turbines based on 32,400 scfm.			
11. Pollutant Potential, Fugitive, and Actual Emissions Comment: This pollutant is a product of the destructive control devices for NMOC and HAPs: turbines and flaring. Primary Control Device is a pretreatment gas scrubber: desulfurization system			

**F2. EMISSIONS UNIT POLLUTANT DETAIL INFORMATION -
ALLOWABLE EMISSIONS**

Complete if the pollutant identified in Subsection F1 is or would be subject to a numerical emissions limitation.

Allowable Emissions Allowable Emissions 1 of 1

1. Basis for Allowable Emissions Code: (AMBIENT) reduce impact on ambient concentrations (Explain in comment field)	2. Future Effective Date of Allowable Emissions: 31-DEC-09
3. Allowable Emissions and Units: 400 PARTS PER MILLION DRY GAS VOLUME	4. Equivalent Allowable Emissions: 132 lb/hour 575 tons/year
5. Method of Compliance: Inlet LFG monitoring	
6. Allowable Emissions Comment (Description of Operating Method):	

**F1. EMISSIONS UNIT POLLUTANT DETAIL INFORMATION -
POTENTIAL, FUGITIVE, AND ACTUAL EMISSIONS**

(Optional for unregulated emissions units.)

Potential, Estimated Fugitive, and Baseline & Projected Actual Emissions

Complete for each pollutant identified in Subsection E if applying for an air construction permit or concurrent processing of an air construction permit and a revised or renewal Title V permit. Complete for each emissions-limited pollutant identified in Subsection E if applying for an air operation permit.

1. Pollutant Emitted: VOC - Volatile Organic Compounds		2. Total Percent Efficiency of Control:	
3. Potential Emissions: 2.1 lb/hour		9 tons/year	4. Synthetically Limited? <input type="checkbox"/> Yes <input checked="" type="checkbox"/> No
5. Range of Estimated Fugitive Emissions (as applicable): to tons/year			
6. Emission Factor: 232 PPMVD Reference: 2.4-2 NOTE C		7. Emissions Method Code: (3) CALCULATED USING EMISSION FACTOR FROM AP-42/FIRE SYSTEM.	
8.a. Baseline Actual Emissions (if required): 1.4 tons/year		8.b. Baseline 24-month Period: From: 01-FEB-05 To: 01-FEB-07	
9.a. Projected Actual Emissions (if required): tons/year		9.b. Projected Monitoring Period: <input type="checkbox"/> 5 years <input type="checkbox"/> 10 years	
10. Calculation of Emissions: See Appendix B Support Calculations. The emission rate for this pollutant is based on 98% control efficiency through 10 LFG flares, 7 turbines and 2 LFG flares, or a combination of flares and turbines based on 32,400 scfm.			
11. Pollutant Potential, Fugitive, and Actual Emissions Comment:			

**F2. EMISSIONS UNIT POLLUTANT DETAIL INFORMATION -
ALLOWABLE EMISSIONS**

Complete if the pollutant identified in Subsection F1 is or would be subject to a numerical emissions limitation.

No Pollutant Allowable Emissions information submitted.

G. VISIBLE EMISSIONS INFORMATION

Complete if this emissions unit is or would be subject to a unit-specific visible emissions limitation.

Visible Emissions Limitation: Visible Emissions Limitation 1 of 2

1. Visible Emissions Subtype: VE00 - VISIBLE EMISSIONS - 0% NORMAL OPACITY	2. Basis for Allowable Opacity: <input checked="" type="checkbox"/> Rule <input type="checkbox"/> Other
3. Allowable Opacity: Normal Conditions: % Exceptional Conditions: % Maximum Period of Excess Opacity Allowed: min/hour	
4. Method of Compliance: EPA METHOD 22	
5. Visible Emissions Comment: Applicable to Flare control devices. This method does not have a VE opacity limit. It is based on visible emissions only. The exception is 5 minutes in a 2 hour period.	

Visible Emissions Limitation: Visible Emissions Limitation 2 of 2

1. Visible Emissions Subtype: VE20 - VISIBLE EMISSIONS - 20% NORMAL OPACITY	2. Basis for Allowable Opacity: <input checked="" type="checkbox"/> Rule <input type="checkbox"/> Other
3. Allowable Opacity: Normal Conditions: 20% Exceptional Conditions: % Maximum Period of Excess Opacity Allowed: min/hour	
4. Method of Compliance: EPA METHOD 9	
5. Visible Emissions Comment: Applicable to turbine control devices	

H. CONTINUOUS MONITOR INFORMATION

Complete if this emissions unit is or would be subject to continuous monitoring.

Continuous Monitoring System: Continuous Monitor 1 of 3

1. Parameter Code: FO - Flame Outage	2. Pollutant(s):
3. CMS Requirement:	<input type="checkbox"/> Rule <input checked="" type="checkbox"/> Other
4. Monitor Information... Manufacturer: Model Number: Serial Number:	
5. Installation Date:	6. Performance Specification Test Date:
7. Continuous Monitor Comment: Enclosed Flares: flame detector used to verify flame presence.	
Status: Active	

Continuous Monitoring System: Continuous Monitor 2 of 3

1. Parameter Code: FO - Flame Outage	2. Pollutant(s):
3. CMS Requirement:	<input type="checkbox"/> Rule <input checked="" type="checkbox"/> Other
4. Monitor Information... Manufacturer: Model Number: Serial Number:	
5. Installation Date:	6. Performance Specification Test Date:
7. Continuous Monitor Comment: Utility Flares: Thermocouple at flare tip is used to detect flame presence NOT temperature.	
Status: Active	

Continuous Monitoring System: Continuous Monitor 3 of 3

1. Parameter Code: OTHER - Explain in comment field	2. Pollutant(s):
3. CMS Requirement: <input type="checkbox"/> Rule <input checked="" type="checkbox"/> Other	
4. Monitor Information... Manufacturer: Model Number: Serial Number:	
5. Installation Date:	6. Performance Specification Test Date:
7. Continuous Monitor Comment: H2S monitoring device will be installed before and after the LFG desulfurization unit	
Status: Inactive	

I. EMISSIONS UNIT ADDITIONAL INFORMATION

Additional Requirements for All Applications, Except as Otherwise Stated

<p>1. Process Flow Diagram (Required for all permit applications, except Title V air operation permit revision applications if this information was submitted to the department within the previous five years and would not be altered as a result of the revision being sought)</p> <p><input checked="" type="checkbox"/> Applicable <input type="checkbox"/> Previously Submitted, Date: <input checked="" type="checkbox"/> Attachment</p>
<p>2. Fuel Analysis or Specification (Required for all permit applications, except Title V air operation permit revision applications if this information was submitted to the department within the previous five years and would not be altered as a result of the revision being sought)</p> <p><input checked="" type="checkbox"/> Applicable <input type="checkbox"/> Previously Submitted, Date: <input checked="" type="checkbox"/> Attachment</p>
<p>3. Detailed Description of Control Equipment (Required for all permit applications, except Title V air operation permit revision applications if this information was submitted to the department within the previous five years and would not be altered as a result of the revision being sought)</p> <p><input type="checkbox"/> Applicable <input type="checkbox"/> Previously Submitted, Date: <input type="checkbox"/> Attachment</p>
<p>4. Procedures for Startup and Shutdown (Required for all operation permit applications, except Title V air operation permit revision applications if this information was submitted to the department within the previous five years and would not be altered as a result of the revision being sought)</p> <p><input checked="" type="checkbox"/> Applicable <input type="checkbox"/> Previously Submitted, Date: <input checked="" type="checkbox"/> Attachment</p>
<p>5. Operation and Maintenance Plan (Required for all permit applications, except Title V air operation permit revision applications if this information was submitted to the department within the previous five years and would not be altered as a result of the revision being sought)</p> <p><input checked="" type="checkbox"/> Applicable <input type="checkbox"/> Previously Submitted, Date: <input checked="" type="checkbox"/> Attachment</p>
<p>6. Compliance Demonstration Reports/Records</p> <p><input checked="" type="checkbox"/> Applicable <input checked="" type="checkbox"/> Previously Submitted, Date: 25-SEP-06 <input checked="" type="checkbox"/> Attachment</p> <p><input checked="" type="checkbox"/> To Be Submitted, Date (if known): 22-MAR-07</p> <p>Previously Submitted Test Date(s)/Pollutants Tested: CO</p> <p>To be Submitted Test Date(s)/Pollutants Tested: Existing backup flare and the temporary (odor control flare) to be tested for VE via Method 9</p> <p>Note: For FESOP applications, all required compliance demonstration records/reports must be submitted at the time of application. For Title V air operation permit applications, all required compliance demonstration reports/records must be submitted at the time of application, or a compliance plan must be submitted at the time of application.</p>
<p>7. Other Information Required by Rule or Statute</p> <p><input type="checkbox"/> Applicable <input type="checkbox"/> Attachment</p>

Additional Requirements for Title V Air Operation Permit Applications

1. Identification of Applicable Requirements	<input type="checkbox"/> Applicable	<input type="checkbox"/> Attachment
2. Compliance Assurance Monitoring Plan	<input type="checkbox"/> Applicable	<input type="checkbox"/> Attachment
3. Alternative Methods of Operation	<input type="checkbox"/> Applicable	<input type="checkbox"/> Attachment
4. Alternative Modes of Operation (Emissions Trading)	<input type="checkbox"/> Applicable	<input type="checkbox"/> Attachment
5. Acid Rain Part Application		
Certificate of Representation (EPA Form No. 7610-1)	<input type="checkbox"/> Applicable <input type="checkbox"/> Previously Submitted, Date:	<input type="checkbox"/> Attachment
Acid Rain Part (Form No. 62-210.900(1)(a))	<input type="checkbox"/> Applicable <input type="checkbox"/> Previously Submitted, Date:	<input type="checkbox"/> Attachment
Repowering Extension Plan (Form No. 62-210.900(1)(a)1.)	<input type="checkbox"/> Applicable <input type="checkbox"/> Previously Submitted, Date:	<input type="checkbox"/> Attachment
New Unit Exemption (Form No. 62-210.900(1)(a)2.)	<input type="checkbox"/> Applicable <input type="checkbox"/> Previously Submitted, Date:	<input type="checkbox"/> Attachment
Retired Unit Exemption (Form No. 62-210.900(1)(a)3.)	<input type="checkbox"/> Applicable <input type="checkbox"/> Previously Submitted, Date:	<input type="checkbox"/> Attachment
Phase II NOx Compliance Plan (Form No. 62-210.900(1)(a)4.)	<input type="checkbox"/> Applicable <input type="checkbox"/> Previously Submitted, Date:	<input type="checkbox"/> Attachment
Phase II NOx Averaging Plan (Form No. 62-210.900(1)(a)5.)	<input type="checkbox"/> Applicable <input type="checkbox"/> Previously Submitted, Date:	<input type="checkbox"/> Attachment

Additional Requirements for Air Construction Permit Applications

1. Control Technology Review and Analysis (Rules 62-212.400(10) and 62-212.500(7), F.A.C.; 40 CFR 63.43(d) and (e)) <input checked="" type="checkbox"/> Applicable	<input checked="" type="checkbox"/> Attachment
2. Good Engineering Practice Stack Height Analysis (Rule 62-212.400(4)(d), F.A.C., and Rule 62-212.500(4)(f), F.A.C.) <input type="checkbox"/> Applicable	<input type="checkbox"/> Attachment
3. Description of Stack Sampling Facilities (Required for proposed new stack sampling facilities only) <input checked="" type="checkbox"/> Applicable	<input checked="" type="checkbox"/> Attachment

Other Information Regarding this Emissions Unit

1. Other Emissions Unit Information <input checked="" type="checkbox"/> Applicable	<input checked="" type="checkbox"/> Attachment
Note: Provide any other information related to the emissions unit addressed in this Emissions Unit Information Section that is not elsewhere provided in the application, not otherwise required and that you, the applicant, believe may be helpful.	

Additional Requirements Comment

Under Other Emission Unit Information: Appendix A - General MSW Process Description, Appendix B - Support Calculations, Appendix E - LFG Generation Rates & Construction Schedule, and Figure 4 - Aerial Depiction of Landfill Phases

Emission Unit Attachments

Supplemental Item	Electronic File Name	Attachment Description	Electronic Document	Date Uploaded
Control Technology Review and Analysis	Section II Appendix D - BACT Analysis.pdf	Appendix D of the PSD Permit Application Support Documentation - BACT Evaluation Summary	Yes	02/28/2007
Description of Stack Sampling Facilities	Section II Appendix G - Stack Parameters and Sampling Facilities.pdf	Appendix G of PSD Permit Application Support Documentation - Description of Stack Parameters & Sampling Facilities	Yes	02/28/2007
	Good Engineering.doc	Please refer to Section 3.4 of the Air Quality Impact Assessment	Yes	02/28/2007
Process Flow Diagram	Figure 2 - Process Flow Diagram.pdf	Figure 2 - Process Flow Diagram (same as facility Process Flow Diagram)	Yes	02/28/2007
Fuel Analysis or Specification	Section II Appendix C - Fuel Analysis.pdf	Appendix C of the PSD Permit Application Support Documentation - Fuel Analysis	Yes	02/28/2007
Procedures for Startup and Shutdown	Section II Appendix F - Procedures for startup and shut down.pdf	Appendix F of PSD Permit Application Support Documentation - Startup, Shutdown, and Malfunction Plan	Yes	02/28/2007
Operation and Maintenance Plan	O _ M Plan.doc	The O & M Plan for the landfill gas collection and treatment is comprised of several large binders, therefore it will not be submitted but maintained at the facility	Yes	02/28/2007
Compliance Demonstration Reports/Records	Flare Testing Report 09252006.pdf	Recent compliance Demonstation Report	Yes	02/28/2007
Other Emissions Unit Information	Section II Appendix B - Support Calculations.pdf	Appendix B of the PSD Permit Application Support Documentation - Support Calculations	Yes	02/28/2007
	Section II Appendix E - LFG Generation n Construct Sched.pdf	Appendix E - LFG Generation Rates and Construction Schedule	Yes	02/28/2007
	Figure 4 - aerial landfill.pdf	Figure 4 - Aerial Depiction of Landfill Phases	Yes	02/28/2007
	Section II Appendix A - General LF Operations.pdf	Appendix A - General MSW Process Description	Yes	02/28/2007

III. EMISSIONS UNIT INFORMATION
A. GENERAL EMISSIONS UNIT INFORMATION

Title V Air Operation Permit Emissions Unit Classification

1. (Check one, if applying for an initial, revised or renewal Title V air operation permit. Skip this item if applying for an air construction permit or FESOP only.)

The emissions unit addressed in this Emissions Unit Information Section is a regulated emissions unit.

The emissions unit addressed in this Emissions Unit Information Section is an unregulated emissions unit.

Emissions Unit Description and Status

1. Type of Emissions Unit Addressed in this Section: (Check one)

This Emissions Unit Information Section addresses, as a single emissions unit, a single process or production unit, or activity, which produces one or more air pollutants and which has at least one definable emission point (stack or vent).

This Emissions Unit Information Section addresses, as a single emissions unit, a group of process or production units and activities which has at least one definable emission point (stack or vent) but may also produce fugitive emissions.

This Emissions Unit Information Section addresses, as a single emissions unit, one or more process or production units and activities which produce fugitive emissions only.

2. Description of Emissions Unit Addressed in this Section:
 3000SCFM ENC FLARE-application redesignates a control device

3. Emissions Unit Identification Number: 3

4. Emissions Unit Status Code: A	5. Commence Construction Date:	6. Initial Startup Date: 01-JUL-02	7. Emissions Unit Major Group SIC Code: 49	8. Acid Rain Unit? <input type="checkbox"/> Yes <input checked="" type="checkbox"/> No
-------------------------------------	--------------------------------	---------------------------------------	---	--

9. Package Unit Manufacturer: LFG SPECIALITIES, INC. Model Number: EF1045I14

10. Generator Nameplate Rating: MW

11. Emissions Unit Comment:
 Designation as a Emission Unit EU003 to be removed and added as a control device for EU-001 MSW Landfill

Emissions Unit Control Equipment

Code	Equipment	Description
23	FLARING	This application seeks to properly designate this EU as a control device for the MSW landfill (EU-001)

B. EMISSIONS UNIT CAPACITY INFORMATION

(Optional for unregulated emissions units.)

Emissions Unit Operating Capacity and Schedule

No Capacity information submitted.

C. EMISSION POINT (STACK/VENT) INFORMATION

(Optional for unregulated emissions units.)

Emission Point Description and Type

No Emission Point information submitted.

D. SEGMENT (PROCESS/FUEL) INFORMATION

Segment Description and Rate: Segment 1 of 1

1. Segment Description (Process/Fuel Type):		
2. Source Classification Code (SCC): 50100410		3. SCC Units: Million Cubic Feet Waste Gas Burned
4. Maximum Hourly Rate:	5. Maximum Annual Rate:	6. Estimated Annual Activity Factor:
7. Maximum % Sulfur:	8. Maximum % Ash:	9. Million Btu per SCC Unit:
10. Segment Comment:		
Is this a valid segment? No		

E. EMISSIONS UNIT POLLUTANTS

List of Pollutants Emitted by Emissions Unit

1. Pollutant Emitted	2. Primary Control Device Code	3. Secondary Control Device Code	4. Pollutant Regulatory Code	Valid?
CO				No
HAPS				No
NMOC				No
NOX				No
PM				No
PM10				No
SO2			NS	No
VOC				No

**F1. EMISSIONS UNIT POLLUTANT DETAIL INFORMATION -
POTENTIAL, FUGITIVE, AND ACTUAL EMISSIONS**

(Optional for unregulated emissions units.)

Potential, Estimated Fugitive, and Baseline & Projected Actual Emissions

Complete for each pollutant identified in Subsection E if applying for an air construction permit or concurrent processing of an air construction permit and a revised or renewal Title V permit. Complete for each emissions-limited pollutant identified in Subsection E if applying for an air operation permit.

1. Pollutant Emitted: CO - Carbon Monoxide		2. Total Percent Efficiency of Control:	
3. Potential Emissions: lb/hour		tons/year	4. Synthetically Limited? <input type="checkbox"/> Yes <input checked="" type="checkbox"/> No
5. Range of Estimated Fugitive Emissions (as applicable): to tons/year			
6. Emission Factor: Reference:		7. Emissions Method Code:	
8.a. Baseline Actual Emissions (if required): tons/year		8.b. Baseline 24-month Period: From: To:	
9.a. Projected Actual Emissions (if required): tons/year		9.b. Projected Monitoring Period: <input type="checkbox"/> 5 years <input type="checkbox"/> 10 years	
10. Calculation of Emissions:			
11. Pollutant Potential, Fugitive, and Actual Emissions Comment: Not a valid EU.			

**F2. EMISSIONS UNIT POLLUTANT DETAIL INFORMATION -
ALLOWABLE EMISSIONS**

Complete if the pollutant identified in Subsection F1 is or would be subject to a numerical emissions limitation.

Allowable Emissions Allowable Emissions 1 of 1

1. Basis for Allowable Emissions Code:	2. Future Effective Date of Allowable Emissions:
3. Allowable Emissions and Units: POUNDS PER MILLION BTU HEAT INPUT	4. Equivalent Allowable Emissions: lb/hour tons/year
5. Method of Compliance:	
6. Allowable Emissions Comment (Description of Operating Method):	

F1. EMISSIONS UNIT POLLUTANT DETAIL INFORMATION - POTENTIAL, FUGITIVE, AND ACTUAL EMISSIONS

(Optional for unregulated emissions units.)

Potential, Estimated Fugitive, and Baseline & Projected Actual Emissions

Complete for each pollutant identified in Subsection E if applying for an air construction permit or concurrent processing of an air construction permit and a revised or renewal Title V permit. Complete for each emissions-limited pollutant identified in Subsection E if applying for an air operation permit.

1. Pollutant Emitted: HAPS - Total Hazardous Air Pollutants		2. Total Percent Efficiency of Control:	
3. Potential Emissions: lb/hour		tons/year	4. Synthetically Limited? <input type="checkbox"/> Yes <input checked="" type="checkbox"/> No
5. Range of Estimated Fugitive Emissions (as applicable): to tons/year			
6. Emission Factor: Reference:		7. Emissions Method Code:	
8.a. Baseline Actual Emissions (if required): tons/year		8.b. Baseline 24-month Period: From: To:	
9.a. Projected Actual Emissions (if required): tons/year		9.b. Projected Monitoring Period: <input type="checkbox"/> 5 years <input type="checkbox"/> 10 years	
10. Calculation of Emissions:			
11. Pollutant Potential, Fugitive, and Actual Emissions Comment: Not a valid EU.			

**F2. EMISSIONS UNIT POLLUTANT DETAIL INFORMATION -
ALLOWABLE EMISSIONS**

Complete if the pollutant identified in Subsection F1 is or would be subject to a numerical emissions limitation.

No Pollutant Allowable Emissions information submitted.

**F1. EMISSIONS UNIT POLLUTANT DETAIL INFORMATION -
POTENTIAL, FUGITIVE, AND ACTUAL EMISSIONS**

(Optional for unregulated emissions units.)

Potential, Estimated Fugitive, and Baseline & Projected Actual Emissions

Complete for each pollutant identified in Subsection E if applying for an air construction permit or concurrent processing of an air construction permit and a revised or renewal Title V permit. Complete for each emissions-limited pollutant identified in Subsection E if applying for an air operation permit.

1. Pollutant Emitted: NMOC - Nonmethane Organic Compounds from MSW Landfill		2. Total Percent Efficiency of Control:	
3. Potential Emissions: lb/hour		tons/year	4. Synthetically Limited? <input type="checkbox"/> Yes <input checked="" type="checkbox"/> No
5. Range of Estimated Fugitive Emissions (as applicable): to tons/year			
6. Emission Factor: Reference:		7. Emissions Method Code:	
8.a. Baseline Actual Emissions (if required): tons/year		8.b. Baseline 24-month Period: From: To:	
9.a. Projected Actual Emissions (if required): tons/year		9.b. Projected Monitoring Period: <input type="checkbox"/> 5 years <input type="checkbox"/> 10 years	
10. Calculation of Emissions:			
11. Pollutant Potential, Fugitive, and Actual Emissions Comment: Not a valid EU.			

F2. EMISSIONS UNIT POLLUTANT DETAIL INFORMATION - ALLOWABLE EMISSIONS

Complete if the pollutant identified in Subsection F1 is or would be subject to a numerical emissions limitation.

Allowable Emissions Allowable Emissions 1 of 2

1. Basis for Allowable Emissions Code:	2. Future Effective Date of Allowable Emissions:
3. Allowable Emissions and Units:	4. Equivalent Allowable Emissions: <div style="display: flex; justify-content: space-around; font-size: small;"> lb/hour tons/year </div>
5. Method of Compliance:	
6. Allowable Emissions Comment (Description of Operating Method):	

Allowable Emissions Allowable Emissions 2 of 2

1. Basis for Allowable Emissions Code:	2. Future Effective Date of Allowable Emissions:
3. Allowable Emissions and Units:	4. Equivalent Allowable Emissions: <div style="display: flex; justify-content: space-around; font-size: small;"> lb/hour tons/year </div>
5. Method of Compliance:	
6. Allowable Emissions Comment (Description of Operating Method):	

**F1. EMISSIONS UNIT POLLUTANT DETAIL INFORMATION -
POTENTIAL, FUGITIVE, AND ACTUAL EMISSIONS**

(Optional for unregulated emissions units.)

Potential, Estimated Fugitive, and Baseline & Projected Actual Emissions

Complete for each pollutant identified in Subsection E if applying for an air construction permit or concurrent processing of an air construction permit and a revised or renewal Title V permit. Complete for each emissions-limited pollutant identified in Subsection E if applying for an air operation permit.

1. Pollutant Emitted: NOX - Nitrogen Oxides		2. Total Percent Efficiency of Control:	
3. Potential Emissions: lb/hour		tons/year	4. Synthetically Limited? <input type="checkbox"/> Yes <input checked="" type="checkbox"/> No
5. Range of Estimated Fugitive Emissions (as applicable): to tons/year			
6. Emission Factor: Reference:		7. Emissions Method Code:	
8.a. Baseline Actual Emissions (if required): tons/year		8.b. Baseline 24-month Period: From: To:	
9.a. Projected Actual Emissions (if required): tons/year		9.b. Projected Monitoring Period: <input type="checkbox"/> 5 years <input type="checkbox"/> 10 years	
10. Calculation of Emissions:			
11. Pollutant Potential, Fugitive, and Actual Emissions Comment: Not a valid EU.			

**F2. EMISSIONS UNIT POLLUTANT DETAIL INFORMATION -
ALLOWABLE EMISSIONS**

Complete if the pollutant identified in Subsection F1 is or would be subject to a numerical emissions limitation.

No Pollutant Allowable Emissions information submitted.

**F1. EMISSIONS UNIT POLLUTANT DETAIL INFORMATION -
POTENTIAL, FUGITIVE, AND ACTUAL EMISSIONS**

(Optional for unregulated emissions units.)

Potential, Estimated Fugitive, and Baseline & Projected Actual Emissions

Complete for each pollutant identified in Subsection E if applying for an air construction permit or concurrent processing of an air construction permit and a revised or renewal Title V permit. Complete for each emissions-limited pollutant identified in Subsection E if applying for an air operation permit.

1. Pollutant Emitted: PM - Particulate Matter - Total		2. Total Percent Efficiency of Control:	
3. Potential Emissions: lb/hour		tons/year	4. Synthetically Limited? <input type="checkbox"/> Yes <input checked="" type="checkbox"/> No
5. Range of Estimated Fugitive Emissions (as applicable): to tons/year			
6. Emission Factor: Reference:		7. Emissions Method Code:	
8.a. Baseline Actual Emissions (if required): tons/year		8.b. Baseline 24-month Period: From: To:	
9.a. Projected Actual Emissions (if required): tons/year		9.b. Projected Monitoring Period: <input type="checkbox"/> 5 years <input type="checkbox"/> 10 years	
10. Calculation of Emissions:			
11. Pollutant Potential, Fugitive, and Actual Emissions Comment: Not a valid EU.			

**F2. EMISSIONS UNIT POLLUTANT DETAIL INFORMATION -
ALLOWABLE EMISSIONS**

Complete if the pollutant identified in Subsection F1 is or would be subject to a numerical emissions limitation.

No Pollutant Allowable Emissions information submitted.

**F1. EMISSIONS UNIT POLLUTANT DETAIL INFORMATION -
POTENTIAL, FUGITIVE, AND ACTUAL EMISSIONS**

(Optional for unregulated emissions units.)

Potential, Estimated Fugitive, and Baseline & Projected Actual Emissions

Complete for each pollutant identified in Subsection E if applying for an air construction permit or concurrent processing of an air construction permit and a revised or renewal Title V permit. Complete for each emissions-limited pollutant identified in Subsection E if applying for an air operation permit.

1. Pollutant Emitted: PM10 - Particulate Matter - PM10		2. Total Percent Efficiency of Control:	
3. Potential Emissions: lb/hour		4. Synthetically Limited? <input type="checkbox"/> Yes <input checked="" type="checkbox"/> No	tons/year
5. Range of Estimated Fugitive Emissions (as applicable): to tons/year			
6. Emission Factor: Reference:		7. Emissions Method Code:	
8.a. Baseline Actual Emissions (if required): tons/year		8.b. Baseline 24-month Period: From: To:	
9.a. Projected Actual Emissions (if required): tons/year		9.b. Projected Monitoring Period: <input type="checkbox"/> 5 years <input type="checkbox"/> 10 years	
10. Calculation of Emissions:			
11. Pollutant Potential, Fugitive, and Actual Emissions Comment: Not a valid EU.			

**F2. EMISSIONS UNIT POLLUTANT DETAIL INFORMATION -
ALLOWABLE EMISSIONS**

Complete if the pollutant identified in Subsection F1 is or would be subject to a numerical emissions limitation.

No Pollutant Allowable Emissions information submitted.

**F1. EMISSIONS UNIT POLLUTANT DETAIL INFORMATION -
POTENTIAL, FUGITIVE, AND ACTUAL EMISSIONS**

(Optional for unregulated emissions units.)

Potential, Estimated Fugitive, and Baseline & Projected Actual Emissions

Complete for each pollutant identified in Subsection E if applying for an air construction permit or concurrent processing of an air construction permit and a revised or renewal Title V permit. Complete for each emissions-limited pollutant identified in Subsection E if applying for an air operation permit.

1. Pollutant Emitted: SO2 - Sulfur Dioxide		2. Total Percent Efficiency of Control:	
3. Potential Emissions: lb/hour		4. Synthetically Limited? <input type="checkbox"/> Yes <input checked="" type="checkbox"/> No	
5. Range of Estimated Fugitive Emissions (as applicable): to tons/year			
6. Emission Factor: Reference:		7. Emissions Method Code:	
8.a. Baseline Actual Emissions (if required): tons/year		8.b. Baseline 24-month Period: From: To:	
9.a. Projected Actual Emissions (if required): tons/year		9.b. Projected Monitoring Period: <input type="checkbox"/> 5 years <input type="checkbox"/> 10 years	
10. Calculation of Emissions:			
11. Pollutant Potential, Fugitive, and Actual Emissions Comment: Not a valid EU.			

**F2. EMISSIONS UNIT POLLUTANT DETAIL INFORMATION -
ALLOWABLE EMISSIONS**

Complete if the pollutant identified in Subsection F1 is or would be subject to a numerical emissions limitation.

No Pollutant Allowable Emissions information submitted.

**F1. EMISSIONS UNIT POLLUTANT DETAIL INFORMATION -
POTENTIAL, FUGITIVE, AND ACTUAL EMISSIONS**

(Optional for unregulated emissions units.)

Potential, Estimated Fugitive, and Baseline & Projected Actual Emissions

Complete for each pollutant identified in Subsection E if applying for an air construction permit or concurrent processing of an air construction permit and a revised or renewal Title V permit. Complete for each emissions-limited pollutant identified in Subsection E if applying for an air operation permit.

1. Pollutant Emitted: VOC - Volatile Organic Compounds		2. Total Percent Efficiency of Control:	
3. Potential Emissions: lb/hour		tons/year	4. Synthetically Limited? <input type="checkbox"/> Yes <input checked="" type="checkbox"/> No
5. Range of Estimated Fugitive Emissions (as applicable): to tons/year			
6. Emission Factor: Reference:		7. Emissions Method Code:	
8.a. Baseline Actual Emissions (if required): tons/year		8.b. Baseline 24-month Period: From: To:	
9.a. Projected Actual Emissions (if required): tons/year		9.b. Projected Monitoring Period: <input type="checkbox"/> 5 years <input type="checkbox"/> 10 years	
10. Calculation of Emissions:			
11. Pollutant Potential, Fugitive, and Actual Emissions Comment:			

**F2. EMISSIONS UNIT POLLUTANT DETAIL INFORMATION -
ALLOWABLE EMISSIONS**

Complete if the pollutant identified in Subsection F1 is or would be subject to a numerical emissions limitation.

No Pollutant Allowable Emissions information submitted.

G. VISIBLE EMISSIONS INFORMATION

Complete if this emissions unit is or would be subject to a unit-specific visible emissions limitation.

No Visible Emissions information submitted.

H. CONTINUOUS MONITOR INFORMATION

Complete if this emissions unit is or would be subject to continuous monitoring.

No Continuous Monitoring information submitted.

I. EMISSIONS UNIT ADDITIONAL INFORMATION

Additional Requirements for All Applications, Except as Otherwise Stated

<p>1. Process Flow Diagram (Required for all permit applications, except Title V air operation permit revision applications if this information was submitted to the department within the previous five years and would not be altered as a result of the revision being sought)</p> <p><input type="checkbox"/> Applicable <input type="checkbox"/> Previously Submitted, Date: <input type="checkbox"/> Attachment</p>
<p>2. Fuel Analysis or Specification (Required for all permit applications, except Title V air operation permit revision applications if this information was submitted to the department within the previous five years and would not be altered as a result of the revision being sought)</p> <p><input type="checkbox"/> Applicable <input type="checkbox"/> Previously Submitted, Date: <input type="checkbox"/> Attachment</p>
<p>3. Detailed Description of Control Equipment (Required for all permit applications, except Title V air operation permit revision applications if this information was submitted to the department within the previous five years and would not be altered as a result of the revision being sought)</p> <p><input type="checkbox"/> Applicable <input type="checkbox"/> Previously Submitted, Date: <input type="checkbox"/> Attachment</p>
<p>4. Procedures for Startup and Shutdown (Required for all operation permit applications, except Title V air operation permit revision applications if this information was submitted to the department within the previous five years and would not be altered as a result of the revision being sought)</p> <p><input type="checkbox"/> Applicable <input type="checkbox"/> Previously Submitted, Date: <input type="checkbox"/> Attachment</p>
<p>5. Operation and Maintenance Plan (Required for all permit applications, except Title V air operation permit revision applications if this information was submitted to the department within the previous five years and would not be altered as a result of the revision being sought)</p> <p><input type="checkbox"/> Applicable <input type="checkbox"/> Previously Submitted, Date: <input type="checkbox"/> Attachment</p>
<p>6. Compliance Demonstration Reports/Records</p> <p><input type="checkbox"/> Applicable <input type="checkbox"/> Previously Submitted, Date: <input type="checkbox"/> Attachment</p> <p style="padding-left: 40px;"><input type="checkbox"/> To Be Submitted, Date (if known):</p> <p>Previously Submitted Test Date(s)/Pollutants Tested:</p> <p>To be Submitted Test Date(s)/Pollutants Tested:</p> <p>Note: For FESOP applications, all required compliance demonstration records/reports must be submitted at the time of application. For Title V air operation permit applications, all required compliance demonstration reports/records must be submitted at the time of application, or a compliance plan must be submitted at the time of application.</p>
<p>7. Other Information Required by Rule or Statute</p> <p><input type="checkbox"/> Applicable <input type="checkbox"/> Attachment</p>

Additional Requirements for Title V Air Operation Permit Applications

1. Identification of Applicable Requirements <input type="checkbox"/> Applicable	<input type="checkbox"/> Attachment
2. Compliance Assurance Monitoring Plan <input type="checkbox"/> Applicable	<input type="checkbox"/> Attachment
3. Alternative Methods of Operation <input type="checkbox"/> Applicable	<input type="checkbox"/> Attachment
4. Alternative Modes of Operation (Emissions Trading) <input type="checkbox"/> Applicable	<input type="checkbox"/> Attachment
5. Acid Rain Part Application	
Certificate of Representation (EPA Form No. 7610-1) <input type="checkbox"/> Applicable <input type="checkbox"/> Previously Submitted, Date:	<input type="checkbox"/> Attachment
Acid Rain Part (Form No. 62-210.900(1)(a)) <input type="checkbox"/> Applicable <input type="checkbox"/> Previously Submitted, Date:	<input type="checkbox"/> Attachment
Repowering Extension Plan (Form No. 62-210.900(1)(a)1.) <input type="checkbox"/> Applicable <input type="checkbox"/> Previously Submitted, Date:	<input type="checkbox"/> Attachment
New Unit Exemption (Form No. 62-210.900(1)(a)2.) <input type="checkbox"/> Applicable <input type="checkbox"/> Previously Submitted, Date:	<input type="checkbox"/> Attachment
Retired Unit Exemption (Form No. 62-210.900(1)(a)3.) <input type="checkbox"/> Applicable <input type="checkbox"/> Previously Submitted, Date:	<input type="checkbox"/> Attachment
Phase II NOx Compliance Plan (Form No. 62-210.900(1)(a)4.) <input type="checkbox"/> Applicable <input type="checkbox"/> Previously Submitted, Date:	<input type="checkbox"/> Attachment
Phase II NOx Averaging Plan (Form No. 62-210.900(1)(a)5.) <input type="checkbox"/> Applicable <input type="checkbox"/> Previously Submitted, Date:	<input type="checkbox"/> Attachment

Additional Requirements for Air Construction Permit Applications

1. Control Technology Review and Analysis (Rules 62-212.400(10) and 62-212.500(7), F.A.C.; 40 CFR 63.43(d) and (e)) <input type="checkbox"/> Applicable <input type="checkbox"/> Attachment
2. Good Engineering Practice Stack Height Analysis (Rule 62-212.400(4)(d), F.A.C., and Rule 62-212.500(4)(f), F.A.C.) <input type="checkbox"/> Applicable <input type="checkbox"/> Attachment
3. Description of Stack Sampling Facilities (Required for proposed new stack sampling facilities only) <input type="checkbox"/> Applicable <input type="checkbox"/> Attachment

Other Information Regarding this Emissions Unit

1. Other Emissions Unit Information <input type="checkbox"/> Applicable <input type="checkbox"/> Attachment Note: Provide any other information related to the emissions unit addressed in this Emissions Unit Information Section that is not elsewhere provided in the application, not otherwise required and that you, the applicant, believe may be helpful.

Additional Requirements Comment

--

III. EMISSIONS UNIT INFORMATION

A. GENERAL EMISSIONS UNIT INFORMATION

Title V Air Operation Permit Emissions Unit Classification

1. (Check one, if applying for an initial, revised or renewal Title V air operation permit. Skip this item if applying for an air construction permit or FESOP only.)
- The emissions unit addressed in this Emissions Unit Information Section is a regulated emissions unit.
- The emissions unit addressed in this Emissions Unit Information Section is an unregulated emissions unit.

Emissions Unit Description and Status

1. Type of Emissions Unit Addressed in this Section: (Check one)
- This Emissions Unit Information Section addresses, as a single emissions unit, a single process or production unit, or activity, which produces one or more air pollutants and which has at least one definable emission point (stack or vent).
- This Emissions Unit Information Section addresses, as a single emissions unit, a group of process or production units and activities which has at least one definable emission point (stack or vent) but may also produce fugitive emissions.
- This Emissions Unit Information Section addresses, as a single emissions unit, one or more process or production units and activities which produce fugitive emissions only.

2. Description of Emissions Unit Addressed in this Section:
3000 SCFM OPEN FLARE-application redesignates a control dev.

3. Emissions Unit Identification Number: 4

4. Emissions Unit Status Code: A	5. Commence Construction Date:	6. Initial Startup Date: 01-DEC-98	7. Emissions Unit Major Group SIC Code: 49	8. Acid Rain Unit? <input type="checkbox"/> Yes <input checked="" type="checkbox"/> No
-------------------------------------	--------------------------------	---------------------------------------	---	--

9. Package Unit Manufacturer: _____ Model Number: _____

10. Generator Nameplate Rating: _____ MW

11. Emissions Unit Comment:

Emissions Unit Control Equipment

Code	Equipment	Description
23	FLARING	This application seeks to properly designate this EU as a control device for the MSW landfill (EU-001)

B. EMISSIONS UNIT CAPACITY INFORMATION

(Optional for unregulated emissions units.)

Emissions Unit Operating Capacity and Schedule

No Capacity information submitted.

C. EMISSION POINT (STACK/VENT) INFORMATION

(Optional for unregulated emissions units.)

Emission Point Description and Type

No Emission Point information submitted.

D. SEGMENT (PROCESS/FUEL) INFORMATION

Segment Description and Rate: Segment 1 of 1

1. Segment Description (Process/Fuel Type):		
2. Source Classification Code (SCC): 50100410	3. SCC Units: Million Cubic Feet Waste Gas Burned	
4. Maximum Hourly Rate:	5. Maximum Annual Rate:	6. Estimated Annual Activity Factor:
7. Maximum % Sulfur:	8. Maximum % Ash:	9. Million Btu per SCC Unit:
10. Segment Comment:		
Is this a valid segment? No		

E. EMISSIONS UNIT POLLUTANTS

List of Pollutants Emitted by Emissions Unit

1. Pollutant Emitted	2. Primary Control Device Code	3. Secondary Control Device Code	4. Pollutant Regulatory Code	Valid?
CO				No
HAPS				No
NMOC				No
NOX				No
PM10				No
SO2				No
VOC				No

**F1. EMISSIONS UNIT POLLUTANT DETAIL INFORMATION -
POTENTIAL, FUGITIVE, AND ACTUAL EMISSIONS**

(Optional for unregulated emissions units.)

Potential, Estimated Fugitive, and Baseline & Projected Actual Emissions

Complete for each pollutant identified in Subsection E if applying for an air construction permit or concurrent processing of an air construction permit and a revised or renewal Title V permit. Complete for each emissions-limited pollutant identified in Subsection E if applying for an air operation permit.

1. Pollutant Emitted: CO - Carbon Monoxide		2. Total Percent Efficiency of Control:	
3. Potential Emissions: lb/hour		tons/year	4. Synthetically Limited? <input type="checkbox"/> Yes <input checked="" type="checkbox"/> No
5. Range of Estimated Fugitive Emissions (as applicable): to tons/year			
6. Emission Factor: Reference:		7. Emissions Method Code:	
8.a. Baseline Actual Emissions (if required): tons/year		8.b. Baseline 24-month Period: From: To:	
9.a. Projected Actual Emissions (if required): tons/year		9.b. Projected Monitoring Period: <input type="checkbox"/> 5 years <input type="checkbox"/> 10 years	
10. Calculation of Emissions:			
11. Pollutant Potential, Fugitive, and Actual Emissions Comment: Not a valid EU.			

**F2. EMISSIONS UNIT POLLUTANT DETAIL INFORMATION -
ALLOWABLE EMISSIONS**

Complete if the pollutant identified in Subsection F1 is or would be subject to a numerical emissions limitation.

No Pollutant Allowable Emissions information submitted.

**F1. EMISSIONS UNIT POLLUTANT DETAIL INFORMATION -
POTENTIAL, FUGITIVE, AND ACTUAL EMISSIONS**

(Optional for unregulated emissions units.)

Potential, Estimated Fugitive, and Baseline & Projected Actual Emissions

Complete for each pollutant identified in Subsection E if applying for an air construction permit or concurrent processing of an air construction permit and a revised or renewal Title V permit.

Complete for each emissions-limited pollutant identified in Subsection E if applying for an air operation permit.

1. Pollutant Emitted: HAPS - Total Hazardous Air Pollutants		2. Total Percent Efficiency of Control:	
3. Potential Emissions: lb/hour		tons/year	4. Synthetically Limited? <input type="checkbox"/> Yes <input checked="" type="checkbox"/> No
5. Range of Estimated Fugitive Emissions (as applicable): to tons/year			
6. Emission Factor: Reference:		7. Emissions Method Code: (3) CALCULATED USING EMISSION FACTOR FROM AP-42/FIRE SYSTEM.	
8.a. Baseline Actual Emissions (if required): tons/year		8.b. Baseline 24-month Period: From: To:	
9.a. Projected Actual Emissions (if required): tons/year		9.b. Projected Monitoring Period: <input type="checkbox"/> 5 years <input type="checkbox"/> 10 years	
10. Calculation of Emissions:			
11. Pollutant Potential, Fugitive, and Actual Emissions Comment: Not a valid EU.			

**F2. EMISSIONS UNIT POLLUTANT DETAIL INFORMATION -
ALLOWABLE EMISSIONS**

Complete if the pollutant identified in Subsection F1 is or would be subject to a numerical emissions limitation.

No Pollutant Allowable Emissions information submitted.

**F1. EMISSIONS UNIT POLLUTANT DETAIL INFORMATION -
POTENTIAL, FUGITIVE, AND ACTUAL EMISSIONS**

(Optional for unregulated emissions units.)

Potential, Estimated Fugitive, and Baseline & Projected Actual Emissions

Complete for each pollutant identified in Subsection E if applying for an air construction permit or concurrent processing of an air construction permit and a revised or renewal Title V permit. Complete for each emissions-limited pollutant identified in Subsection E if applying for an air operation permit.

1. Pollutant Emitted: NMOC - Nonmethane Organic Compounds from MSW Landfill		2. Total Percent Efficiency of Control:	
3. Potential Emissions: lb/hour		tons/year	4. Synthetically Limited? <input type="checkbox"/> Yes <input checked="" type="checkbox"/> No
5. Range of Estimated Fugitive Emissions (as applicable): to tons/year			
6. Emission Factor: Reference:		7. Emissions Method Code:	
8.a. Baseline Actual Emissions (if required): tons/year		8.b. Baseline 24-month Period: From: To:	
9.a. Projected Actual Emissions (if required): tons/year		9.b. Projected Monitoring Period: <input type="checkbox"/> 5 years <input type="checkbox"/> 10 years	
10. Calculation of Emissions:			
11. Pollutant Potential, Fugitive, and Actual Emissions Comment: Not a valid EU.			

**F2. EMISSIONS UNIT POLLUTANT DETAIL INFORMATION -
ALLOWABLE EMISSIONS**

Complete if the pollutant identified in Subsection F1 is or would be subject to a numerical emissions limitation.

No Pollutant Allowable Emissions information submitted.

F1. EMISSIONS UNIT POLLUTANT DETAIL INFORMATION - POTENTIAL, FUGITIVE, AND ACTUAL EMISSIONS

(Optional for unregulated emissions units.)

Potential, Estimated Fugitive, and Baseline & Projected Actual Emissions

Complete for each pollutant identified in Subsection E if applying for an air construction permit or concurrent processing of an air construction permit and a revised or renewal Title V permit. Complete for each emissions-limited pollutant identified in Subsection E if applying for an air operation permit.

1. Pollutant Emitted: NOX - Nitrogen Oxides	2. Total Percent Efficiency of Control:
3. Potential Emissions: lb/hour tons/year	4. Synthetically Limited? <input type="checkbox"/> Yes <input checked="" type="checkbox"/> No
5. Range of Estimated Fugitive Emissions (as applicable): to tons/year	
6. Emission Factor: Reference:	7. Emissions Method Code:
8.a. Baseline Actual Emissions (if required): tons/year	8.b. Baseline 24-month Period: From: To:
9.a. Projected Actual Emissions (if required): tons/year	9.b. Projected Monitoring Period: <input type="checkbox"/> 5 years <input type="checkbox"/> 10 years
10. Calculation of Emissions:	
11. Pollutant Potential, Fugitive, and Actual Emissions Comment: Not a valid EU.	

**F2. EMISSIONS UNIT POLLUTANT DETAIL INFORMATION -
ALLOWABLE EMISSIONS**

Complete if the pollutant identified in Subsection F1 is or would be subject to a numerical emissions limitation.

No Pollutant Allowable Emissions information submitted.

**F1. EMISSIONS UNIT POLLUTANT DETAIL INFORMATION -
POTENTIAL, FUGITIVE, AND ACTUAL EMISSIONS**

(Optional for unregulated emissions units.)

Potential, Estimated Fugitive, and Baseline & Projected Actual Emissions

Complete for each pollutant identified in Subsection E if applying for an air construction permit or concurrent processing of an air construction permit and a revised or renewal Title V permit. Complete for each emissions-limited pollutant identified in Subsection E if applying for an air operation permit.

1. Pollutant Emitted: PM10 - Particulate Matter - PM10		2. Total Percent Efficiency of Control:	
3. Potential Emissions: lb/hour		tons/year	4. Synthetically Limited? <input type="checkbox"/> Yes <input checked="" type="checkbox"/> No
5. Range of Estimated Fugitive Emissions (as applicable): to tons/year			
6. Emission Factor: Reference:		7. Emissions Method Code:	
8.a. Baseline Actual Emissions (if required): tons/year		8.b. Baseline 24-month Period: From: To:	
9.a. Projected Actual Emissions (if required): tons/year		9.b. Projected Monitoring Period: <input type="checkbox"/> 5 years <input type="checkbox"/> 10 years	
10. Calculation of Emissions:			
11. Pollutant Potential, Fugitive, and Actual Emissions Comment: Not a valid EU.			

**F2. EMISSIONS UNIT POLLUTANT DETAIL INFORMATION -
ALLOWABLE EMISSIONS**

Complete if the pollutant identified in Subsection F1 is or would be subject to a numerical emissions limitation.

No Pollutant Allowable Emissions information submitted.

**F1. EMISSIONS UNIT POLLUTANT DETAIL INFORMATION -
POTENTIAL, FUGITIVE, AND ACTUAL EMISSIONS**

(Optional for unregulated emissions units.)

Potential, Estimated Fugitive, and Baseline & Projected Actual Emissions

Complete for each pollutant identified in Subsection E if applying for an air construction permit or concurrent processing of an air construction permit and a revised or renewal Title V permit.

Complete for each emissions-limited pollutant identified in Subsection E if applying for an air operation permit.

1. Pollutant Emitted: SO2 - Sulfur Dioxide		2. Total Percent Efficiency of Control:	
3. Potential Emissions: lb/hour		tons/year	4. Synthetically Limited? <input type="checkbox"/> Yes <input checked="" type="checkbox"/> No
5. Range of Estimated Fugitive Emissions (as applicable): to tons/year			
6. Emission Factor: Reference:		7. Emissions Method Code:	
8.a. Baseline Actual Emissions (if required): tons/year		8.b. Baseline 24-month Period: From: To:	
9.a. Projected Actual Emissions (if required): tons/year		9.b. Projected Monitoring Period: <input type="checkbox"/> 5 years <input type="checkbox"/> 10 years	
10. Calculation of Emissions:			
11. Pollutant Potential, Fugitive, and Actual Emissions Comment: Not a valid EU.			

**F2. EMISSIONS UNIT POLLUTANT DETAIL INFORMATION -
ALLOWABLE EMISSIONS**

Complete if the pollutant identified in Subsection F1 is or would be subject to a numerical emissions limitation.

No Pollutant Allowable Emissions information submitted.

F1. EMISSIONS UNIT POLLUTANT DETAIL INFORMATION - POTENTIAL, FUGITIVE, AND ACTUAL EMISSIONS

(Optional for unregulated emissions units.)

Potential, Estimated Fugitive, and Baseline & Projected Actual Emissions

Complete for each pollutant identified in Subsection E if applying for an air construction permit or concurrent processing of an air construction permit and a revised or renewal Title V permit. Complete for each emissions-limited pollutant identified in Subsection E if applying for an air operation permit.

1. Pollutant Emitted: VOC - Volatile Organic Compounds	2. Total Percent Efficiency of Control:
3. Potential Emissions: lb/hour	4. Synthetically Limited? <input type="checkbox"/> Yes <input checked="" type="checkbox"/> No
5. Range of Estimated Fugitive Emissions (as applicable): to tons/year	
6. Emission Factor: Reference:	7. Emissions Method Code:
8.a. Baseline Actual Emissions (if required): tons/year	8.b. Baseline 24-month Period: From: To:
9.a. Projected Actual Emissions (if required): tons/year	9.b. Projected Monitoring Period: <input type="checkbox"/> 5 years <input type="checkbox"/> 10 years
10. Calculation of Emissions:	
11. Pollutant Potential, Fugitive, and Actual Emissions Comment: Not a valid EU.	

**F2. EMISSIONS UNIT POLLUTANT DETAIL INFORMATION -
ALLOWABLE EMISSIONS**

Complete if the pollutant identified in Subsection F1 is or would be subject to a numerical emissions limitation.

No Pollutant Allowable Emissions information submitted.

G. VISIBLE EMISSIONS INFORMATION

Complete if this emissions unit is or would be subject to a unit-specific visible emissions limitation.

Visible Emissions Limitation: Visible Emissions Limitation 1 of 1

<p>1. Visible Emissions Subtype: VE00 - VISIBLE EMISSIONS - 0% NORMAL OPACITY</p>	<p>2. Basis for Allowable Opacity: <input checked="" type="checkbox"/> Rule <input type="checkbox"/> Other</p>
<p>3. Allowable Opacity: Normal Conditions: % Exceptional Conditions: % Maximum Period of Excess Opacity Allowed: min/hour</p>	
<p>4. Method of Compliance:</p>	
<p>5. Visible Emissions Comment: The standard is based on METHOD 22. NO VE except for 5 MINUTES in any 2 CONSECUTIVE Hour period</p>	

H. CONTINUOUS MONITOR INFORMATION

Complete if this emissions unit is or would be subject to continuous monitoring.

Continuous Monitoring System: Continuous Monitor 1 of 2

1. Parameter Code: FO - Flame Outage	2. Pollutant(s):
3. CMS Requirement:	<input type="checkbox"/> Rule <input type="checkbox"/> Other
4. Monitor Information... Manufacturer: LFG SPECIALITIES Model Number: PCF1228I10 Serial Number:	
5. Installation Date: 01-SEP-02	6. Performance Specification Test Date:
7. Continuous Monitor Comment:	
Status: Active	

Continuous Monitoring System: Continuous Monitor 2 of 2

1. Parameter Code: FLOW - Volumetric flow rate	2. Pollutant(s):
3. CMS Requirement:	<input type="checkbox"/> Rule <input type="checkbox"/> Other
4. Monitor Information... Manufacturer: LFG SPECIALITIES Model Number: EF1150I14 Serial Number: 1698	
5. Installation Date: 01-JAN-01	6. Performance Specification Test Date:
7. Continuous Monitor Comment:	
Status: Active	

I. EMISSIONS UNIT ADDITIONAL INFORMATION**Additional Requirements for All Applications, Except as Otherwise Stated**

1. Process Flow Diagram (Required for all permit applications, except Title V air operation permit revision applications if this information was submitted to the department within the previous five years and would not be altered as a result of the revision being sought)	<input type="checkbox"/> Applicable	<input type="checkbox"/> Previously Submitted, Date:	<input type="checkbox"/> Attachment
2. Fuel Analysis or Specification (Required for all permit applications, except Title V air operation permit revision applications if this information was submitted to the department within the previous five years and would not be altered as a result of the revision being sought)	<input type="checkbox"/> Applicable	<input type="checkbox"/> Previously Submitted, Date:	<input type="checkbox"/> Attachment
3. Detailed Description of Control Equipment (Required for all permit applications, except Title V air operation permit revision applications if this information was submitted to the department within the previous five years and would not be altered as a result of the revision being sought)	<input type="checkbox"/> Applicable	<input type="checkbox"/> Previously Submitted, Date:	<input type="checkbox"/> Attachment
4. Procedures for Startup and Shutdown (Required for all operation permit applications, except Title V air operation permit revision applications if this information was submitted to the department within the previous five years and would not be altered as a result of the revision being sought)	<input type="checkbox"/> Applicable	<input type="checkbox"/> Previously Submitted, Date:	<input type="checkbox"/> Attachment
5. Operation and Maintenance Plan (Required for all permit applications, except Title V air operation permit revision applications if this information was submitted to the department within the previous five years and would not be altered as a result of the revision being sought)	<input type="checkbox"/> Applicable	<input type="checkbox"/> Previously Submitted, Date:	<input type="checkbox"/> Attachment
6. Compliance Demonstration Reports/Records	<input type="checkbox"/> Applicable	<input type="checkbox"/> Previously Submitted, Date:	<input type="checkbox"/> Attachment
		<input type="checkbox"/> To Be Submitted, Date (if known):	
Previously Submitted Test Date(s)/Pollutants Tested:			
To be Submitted Test Date(s)/Pollutants Tested:			
Note: For FESOP applications, all required compliance demonstration records/reports must be submitted at the time of application. For Title V air operation permit applications, all required compliance demonstration reports/records must be submitted at the time of application, or a compliance plan must be submitted at the time of application.			
7. Other Information Required by Rule or Statute	<input type="checkbox"/> Applicable		<input type="checkbox"/> Attachment

Additional Requirements for Title V Air Operation Permit Applications

1. Identification of Applicable Requirements <input type="checkbox"/> Applicable	<input type="checkbox"/> Attachment
2. Compliance Assurance Monitoring Plan <input type="checkbox"/> Applicable	<input type="checkbox"/> Attachment
3. Alternative Methods of Operation <input type="checkbox"/> Applicable	<input type="checkbox"/> Attachment
4. Alternative Modes of Operation (Emissions Trading) <input type="checkbox"/> Applicable	<input type="checkbox"/> Attachment
5. Acid Rain Part Application	
Certificate of Representation (EPA Form No. 7610-1) <input type="checkbox"/> Applicable <input type="checkbox"/> Previously Submitted, Date:	<input type="checkbox"/> Attachment
Acid Rain Part (Form No. 62-210.900(1)(a)) <input type="checkbox"/> Applicable <input type="checkbox"/> Previously Submitted, Date:	<input type="checkbox"/> Attachment
Repowering Extension Plan (Form No. 62-210.900(1)(a)1.) <input type="checkbox"/> Applicable <input type="checkbox"/> Previously Submitted, Date:	<input type="checkbox"/> Attachment
New Unit Exemption (Form No. 62-210.900(1)(a)2.) <input type="checkbox"/> Applicable <input type="checkbox"/> Previously Submitted, Date:	<input type="checkbox"/> Attachment
Retired Unit Exemption (Form No. 62-210.900(1)(a)3.) <input type="checkbox"/> Applicable <input type="checkbox"/> Previously Submitted, Date:	<input type="checkbox"/> Attachment
Phase II NOx Compliance Plan (Form No. 62-210.900(1)(a)4.) <input type="checkbox"/> Applicable <input type="checkbox"/> Previously Submitted, Date:	<input type="checkbox"/> Attachment
Phase II NOx Averaging Plan (Form No. 62-210.900(1)(a)5.) <input type="checkbox"/> Applicable <input type="checkbox"/> Previously Submitted, Date:	<input type="checkbox"/> Attachment

Additional Requirements for Air Construction Permit Applications

1. Control Technology Review and Analysis (Rules 62-212.400(10) and 62-212.500(7), F.A.C.; 40 CFR 63.43(d) and (e)) <input type="checkbox"/> Applicable <input type="checkbox"/> Attachment
2. Good Engineering Practice Stack Height Analysis (Rule 62-212.400(4)(d), F.A.C., and Rule 62-212.500(4)(f), F.A.C.) <input type="checkbox"/> Applicable <input type="checkbox"/> Attachment
3. Description of Stack Sampling Facilities (Required for proposed new stack sampling facilities only) <input type="checkbox"/> Applicable <input type="checkbox"/> Attachment

Other Information Regarding this Emissions Unit

1. Other Emissions Unit Information <input type="checkbox"/> Applicable <input type="checkbox"/> Attachment Note: Provide any other information related to the emissions unit addressed in this Emissions Unit Information Section that is not elsewhere provided in the application, not otherwise required and that you, the applicant, believe may be helpful.
--

Additional Requirements Comment

EU-004 is not part of the proposed project for this Title V operation and construction permit application. The changes/updates herein are administrative only.
--

III. EMISSIONS UNIT INFORMATION
A. GENERAL EMISSIONS UNIT INFORMATION

Title V Air Operation Permit Emissions Unit Classification

1. (Check one, if applying for an initial, revised or renewal Title V air operation permit. Skip this item if applying for an air construction permit or FESOP only.)

The emissions unit addressed in this Emissions Unit Information Section is a regulated emissions unit.

The emissions unit addressed in this Emissions Unit Information Section is an unregulated emissions unit.

Emissions Unit Description and Status

1. Type of Emissions Unit Addressed in this Section: (Check one)

This Emissions Unit Information Section addresses, as a single emissions unit, a single process or production unit, or activity, which produces one or more air pollutants and which has at least one definable emission point (stack or vent).

This Emissions Unit Information Section addresses, as a single emissions unit, a group of process or production units and activities which has at least one definable emission point (stack or vent) but may also produce fugitive emissions.

This Emissions Unit Information Section addresses, as a single emissions unit, one or more process or production units and activities which produce fugitive emissions only.

2. Description of Emissions Unit Addressed in this Section:
 3000SCFM ENC FLARE-application redesignates a control device

3. Emissions Unit Identification Number: 5

4. Emissions Unit Status Code: A	5. Commence Construction Date:	6. Initial Startup Date: 01-APR-05	7. Emissions Unit Major Group SIC Code: 49	8. Acid Rain Unit? <input type="checkbox"/> Yes <input checked="" type="checkbox"/> No
-------------------------------------	--------------------------------	---------------------------------------	---	--

9. Package Unit Manufacturer: LFG SPECIALTIES, INC. Model Number: EF1045112

10. Generator Nameplate Rating: MW

11. Emissions Unit Comment:

Emissions Unit Control Equipment

Code	Equipment	Description
23	FLARING	This application seeks to properly designate this EU as a control device for the MSW landfill (EU-001)

B. EMISSIONS UNIT CAPACITY INFORMATION

(Optional for unregulated emissions units.)

Emissions Unit Operating Capacity and Schedule

1.	Maximum Process or Throughput Rate: 3000 SCFM LFG		
2.	Maximum Production Rate:		
3.	Maximum Heat Input Rate: 99 million Btu/hr		
4.	Maximum Incineration Rate:	pounds/hr	
		tons/day	
5.	Requested Maximum Operating Schedule:	24 hours/day	7 days/week
		52 weeks/year	8760 hours/year
6.	Operating Capacity/Schedule Comment:		

C. EMISSION POINT (STACK/VENT) INFORMATION

(Optional for unregulated emissions units.)

Emission Point Description and Type

1. Identification of Point on Plot Plan or Flow Diagram:		2. Emission Point Type Code: 1 - A single emission point serving a single emissions unit	
3. Descriptions of Emission Points Comprising this Emissions Unit for VE Tracking:			
4. ID Numbers or Descriptions of Emission Units with this Emission Point in Common:			
5. Discharge Type Code: (V) A STACK WITH AN UNOBSTRUCTED OPENING DISCHARGING IN A VERTICAL/NEARLY VERTICAL DIRECTION		6. Stack Height: feet	7. Exit Diameter: feet
8. Exit Temperature: 1400° F	9. Actual Volumetric Flow Rate: 196340 acfm	10. Water Vapor: 8 %	
11. Maximum Dry Standard Flow Rate: 2760 dscfm		12. Nonstack Emission Point Height: feet	
13. Emission Point UTM Coordinates... Zone: East (km): 530.705 North (km): 3024.018		14. Emission Point Latitude/Longitude... Latitude: Longitude:	
15. Emission Point Comment:			

D. SEGMENT (PROCESS/FUEL) INFORMATION**Segment Description and Rate:** Segment 1 of 1

1. Segment Description (Process/Fuel Type): LFG generated by the MSW is flared (MMcf burned)		
2. Source Classification Code (SCC): 50100410	3. SCC Units: Million Cubic Feet Waste Gas Burned	
4. Maximum Hourly Rate: .18	5. Maximum Annual Rate: 225	6. Estimated Annual Activity Factor:
7. Maximum % Sulfur: .6	8. Maximum % Ash: .1	9. Million Btu per SCC Unit: 550
10. Segment Comment:		
Is this a valid segment? Yes		

E. EMISSIONS UNIT POLLUTANTS**List of Pollutants Emitted by Emissions Unit**

1. Pollutant Emitted	2. Primary Control Device Code	3. Secondary Control Device Code	4. Pollutant Regulatory Code	Valid?
CO				No
HAPS				No
NMOC				No
NOX				No
PM				No
PM10				No
SO2				No
VOC				No

**F1. EMISSIONS UNIT POLLUTANT DETAIL INFORMATION -
POTENTIAL, FUGITIVE, AND ACTUAL EMISSIONS**

(Optional for unregulated emissions units.)

Potential, Estimated Fugitive, and Baseline & Projected Actual Emissions

Complete for each pollutant identified in Subsection E if applying for an air construction permit or concurrent processing of an air construction permit and a revised or renewal Title V permit.

Complete for each emissions-limited pollutant identified in Subsection E if applying for an air operation permit.

1. Pollutant Emitted: CO - Carbon Monoxide		2. Total Percent Efficiency of Control:	
3. Potential Emissions: lb/hour		tons/year	4. Synthetically Limited? <input type="checkbox"/> Yes <input checked="" type="checkbox"/> No
5. Range of Estimated Fugitive Emissions (as applicable): to tons/year			
6. Emission Factor: Reference:		7. Emissions Method Code:	
8.a. Baseline Actual Emissions (if required): tons/year		8.b. Baseline 24-month Period: From: To:	
9.a. Projected Actual Emissions (if required): tons/year		9.b. Projected Monitoring Period: <input type="checkbox"/> 5 years <input type="checkbox"/> 10 years	
10. Calculation of Emissions:			
11. Pollutant Potential, Fugitive, and Actual Emissions Comment: Not a valid EU.			

**F2. EMISSIONS UNIT POLLUTANT DETAIL INFORMATION -
ALLOWABLE EMISSIONS**

Complete if the pollutant identified in Subsection F1 is or would be subject to a numerical emissions limitation.

Allowable Emissions Allowable Emissions 1 of 1

1. Basis for Allowable Emissions Code:	2. Future Effective Date of Allowable Emissions:
3. Allowable Emissions and Units:	4. Equivalent Allowable Emissions: lb/hour tons/year
5. Method of Compliance:	
6. Allowable Emissions Comment (Description of Operating Method):	

**F1. EMISSIONS UNIT POLLUTANT DETAIL INFORMATION -
POTENTIAL, FUGITIVE, AND ACTUAL EMISSIONS**

(Optional for unregulated emissions units.)

Potential, Estimated Fugitive, and Baseline & Projected Actual Emissions

Complete for each pollutant identified in Subsection E if applying for an air construction permit or concurrent processing of an air construction permit and a revised or renewal Title V permit. Complete for each emissions-limited pollutant identified in Subsection E if applying for an air operation permit.

1. Pollutant Emitted: HAPS - Total Hazardous Air Pollutants		2. Total Percent Efficiency of Control:	
3. Potential Emissions: lb/hour		tons/year	4. Synthetically Limited? <input type="checkbox"/> Yes <input checked="" type="checkbox"/> No
5. Range of Estimated Fugitive Emissions (as applicable): to tons/year			
6. Emission Factor: Reference:		7. Emissions Method Code:	
8.a. Baseline Actual Emissions (if required): tons/year		8.b. Baseline 24-month Period: From: To:	
9.a. Projected Actual Emissions (if required): tons/year		9.b. Projected Monitoring Period: <input type="checkbox"/> 5 years <input type="checkbox"/> 10 years	
10. Calculation of Emissions:			
11. Pollutant Potential, Fugitive, and Actual Emissions Comment: Not a valid EU.			

**F2. EMISSIONS UNIT POLLUTANT DETAIL INFORMATION -
ALLOWABLE EMISSIONS**

Complete if the pollutant identified in Subsection F1 is or would be subject to a numerical emissions limitation.

No Pollutant Allowable Emissions information submitted.

**F1. EMISSIONS UNIT POLLUTANT DETAIL INFORMATION -
 POTENTIAL, FUGITIVE, AND ACTUAL EMISSIONS**

(Optional for unregulated emissions units.)

Potential, Estimated Fugitive, and Baseline & Projected Actual Emissions

Complete for each pollutant identified in Subsection E if applying for an air construction permit or concurrent processing of an air construction permit and a revised or renewal Title V permit. Complete for each emissions-limited pollutant identified in Subsection E if applying for an air operation permit.

1. Pollutant Emitted: NMOC - Nonmethane Organic Compounds from MSW Landfill		2. Total Percent Efficiency of Control:	
3. Potential Emissions: lb/hour		4. Synthetically Limited? <input type="checkbox"/> Yes <input checked="" type="checkbox"/> No	
5. Range of Estimated Fugitive Emissions (as applicable): to tons/year			
6. Emission Factor: Reference:		7. Emissions Method Code:	
8.a. Baseline Actual Emissions (if required): tons/year		8.b. Baseline 24-month Period: From: To:	
9.a. Projected Actual Emissions (if required): tons/year		9.b. Projected Monitoring Period: <input type="checkbox"/> 5 years <input type="checkbox"/> 10 years	
10. Calculation of Emissions:			
11. Pollutant Potential, Fugitive, and Actual Emissions Comment: Not a valid EU.			

**F2. EMISSIONS UNIT POLLUTANT DETAIL INFORMATION -
ALLOWABLE EMISSIONS**

Complete if the pollutant identified in Subsection F1 is or would be subject to a numerical emissions limitation.

Allowable Emissions Allowable Emissions 1 of 2

1. Basis for Allowable Emissions Code:	2. Future Effective Date of Allowable Emissions:
3. Allowable Emissions and Units:	4. Equivalent Allowable Emissions: lb/hour tons/year
5. Method of Compliance:	
6. Allowable Emissions Comment (Description of Operating Method):	

Allowable Emissions Allowable Emissions 2 of 2

1. Basis for Allowable Emissions Code:	2. Future Effective Date of Allowable Emissions:
3. Allowable Emissions and Units:	4. Equivalent Allowable Emissions: lb/hour tons/year
5. Method of Compliance:	
6. Allowable Emissions Comment (Description of Operating Method):	

**F1. EMISSIONS UNIT POLLUTANT DETAIL INFORMATION -
POTENTIAL, FUGITIVE, AND ACTUAL EMISSIONS**

(Optional for unregulated emissions units.)

Potential, Estimated Fugitive, and Baseline & Projected Actual Emissions

Complete for each pollutant identified in Subsection E if applying for an air construction permit or concurrent processing of an air construction permit and a revised or renewal Title V permit. Complete for each emissions-limited pollutant identified in Subsection E if applying for an air operation permit.

1. Pollutant Emitted: NOX - Nitrogen Oxides		2. Total Percent Efficiency of Control:	
3. Potential Emissions: lb/hour		tons/year	4. Synthetically Limited? <input type="checkbox"/> Yes <input checked="" type="checkbox"/> No
5. Range of Estimated Fugitive Emissions (as applicable): to tons/year			
6. Emission Factor: Reference:		7. Emissions Method Code:	
8.a. Baseline Actual Emissions (if required): tons/year		8.b. Baseline 24-month Period: From: To:	
9.a. Projected Actual Emissions (if required): tons/year		9.b. Projected Monitoring Period: <input type="checkbox"/> 5 years <input type="checkbox"/> 10 years	
10. Calculation of Emissions:			
11. Pollutant Potential, Fugitive, and Actual Emissions Comment: Not a valid EU.			

**F2. EMISSIONS UNIT POLLUTANT DETAIL INFORMATION -
ALLOWABLE EMISSIONS**

Complete if the pollutant identified in Subsection F1 is or would be subject to a numerical emissions limitation.

No Pollutant Allowable Emissions information submitted.

**F1. EMISSIONS UNIT POLLUTANT DETAIL INFORMATION -
POTENTIAL, FUGITIVE, AND ACTUAL EMISSIONS**

(Optional for unregulated emissions units.)

Potential, Estimated Fugitive, and Baseline & Projected Actual Emissions

Complete for each pollutant identified in Subsection E if applying for an air construction permit or concurrent processing of an air construction permit and a revised or renewal Title V permit. Complete for each emissions-limited pollutant identified in Subsection E if applying for an air operation permit.

1. Pollutant Emitted: PM - Particulate Matter - Total		2. Total Percent Efficiency of Control:	
3. Potential Emissions: lb/hour		tons/year	4. Synthetically Limited? <input type="checkbox"/> Yes <input checked="" type="checkbox"/> No
5. Range of Estimated Fugitive Emissions (as applicable): to tons/year			
6. Emission Factor: Reference:		7. Emissions Method Code:	
8.a. Baseline Actual Emissions (if required): tons/year		8.b. Baseline 24-month Period: From: To:	
9.a. Projected Actual Emissions (if required): tons/year		9.b. Projected Monitoring Period: <input type="checkbox"/> 5 years <input type="checkbox"/> 10 years	
10. Calculation of Emissions:			
11. Pollutant Potential, Fugitive, and Actual Emissions Comment: Not a valid EU.			

**F2. EMISSIONS UNIT POLLUTANT DETAIL INFORMATION -
ALLOWABLE EMISSIONS**

Complete if the pollutant identified in Subsection F1 is or would be subject to a numerical emissions limitation.

No Pollutant Allowable Emissions information submitted.

**F1. EMISSIONS UNIT POLLUTANT DETAIL INFORMATION -
POTENTIAL, FUGITIVE, AND ACTUAL EMISSIONS**

(Optional for unregulated emissions units.)

Potential, Estimated Fugitive, and Baseline & Projected Actual Emissions

Complete for each pollutant identified in Subsection E if applying for an air construction permit or concurrent processing of an air construction permit and a revised or renewal Title V permit. Complete for each emissions-limited pollutant identified in Subsection E if applying for an air operation permit.

1. Pollutant Emitted: PM10 - Particulate Matter - PM10		2. Total Percent Efficiency of Control:	
3. Potential Emissions: lb/hour		tons/year	4. Synthetically Limited? <input type="checkbox"/> Yes <input checked="" type="checkbox"/> No
5. Range of Estimated Fugitive Emissions (as applicable): to tons/year			
6. Emission Factor: Reference:		7. Emissions Method Code:	
8.a. Baseline Actual Emissions (if required): tons/year		8.b. Baseline 24-month Period: From: To:	
9.a. Projected Actual Emissions (if required): tons/year		9.b. Projected Monitoring Period: <input type="checkbox"/> 5 years <input type="checkbox"/> 10 years	
10. Calculation of Emissions:			
11. Pollutant Potential, Fugitive, and Actual Emissions Comment: Not a valid EU.			

**F2. EMISSIONS UNIT POLLUTANT DETAIL INFORMATION -
ALLOWABLE EMISSIONS**

Complete if the pollutant identified in Subsection F1 is or would be subject to a numerical emissions limitation.

No Pollutant Allowable Emissions information submitted.

**F1. EMISSIONS UNIT POLLUTANT DETAIL INFORMATION -
POTENTIAL, FUGITIVE, AND ACTUAL EMISSIONS**

(Optional for unregulated emissions units.)

Potential, Estimated Fugitive, and Baseline & Projected Actual Emissions

Complete for each pollutant identified in Subsection E if applying for an air construction permit or concurrent processing of an air construction permit and a revised or renewal Title V permit.

Complete for each emissions-limited pollutant identified in Subsection E if applying for an air operation permit.

1. Pollutant Emitted: SO2 - Sulfur Dioxide		2. Total Percent Efficiency of Control:	
3. Potential Emissions: lb/hour		tons/year	4. Synthetically Limited? <input type="checkbox"/> Yes <input checked="" type="checkbox"/> No
5. Range of Estimated Fugitive Emissions (as applicable): to tons/year			
6. Emission Factor: Reference:		7. Emissions Method Code:	
8.a. Baseline Actual Emissions (if required): tons/year		8.b. Baseline 24-month Period: From: To:	
9.a. Projected Actual Emissions (if required): tons/year		9.b. Projected Monitoring Period: <input type="checkbox"/> 5 years <input type="checkbox"/> 10 years	
10. Calculation of Emissions:			
11. Pollutant Potential, Fugitive, and Actual Emissions Comment: Not a valid EU.			

**F2. EMISSIONS UNIT POLLUTANT DETAIL INFORMATION -
ALLOWABLE EMISSIONS**

Complete if the pollutant identified in Subsection F1 is or would be subject to a numerical emissions limitation.

No Pollutant Allowable Emissions information submitted.

**F2. EMISSIONS UNIT POLLUTANT DETAIL INFORMATION -
ALLOWABLE EMISSIONS**

Complete if the pollutant identified in Subsection F1 is or would be subject to a numerical emissions limitation.

No Pollutant Allowable Emissions information submitted.

G. VISIBLE EMISSIONS INFORMATION

Complete if this emissions unit is or would be subject to a unit-specific visible emissions limitation.

No Visible Emissions information submitted.

H. CONTINUOUS MONITOR INFORMATION

Complete if this emissions unit is or would be subject to continuous monitoring.

No Continuous Monitoring information submitted.

I. EMISSIONS UNIT ADDITIONAL INFORMATION**Additional Requirements for All Applications, Except as Otherwise Stated**

1. Process Flow Diagram (Required for all permit applications, except Title V air operation permit revision applications if this information was submitted to the department within the previous five years and would not be altered as a result of the revision being sought)	<input type="checkbox"/> Applicable	<input type="checkbox"/> Previously Submitted, Date:	<input type="checkbox"/> Attachment
2. Fuel Analysis or Specification (Required for all permit applications, except Title V air operation permit revision applications if this information was submitted to the department within the previous five years and would not be altered as a result of the revision being sought)	<input type="checkbox"/> Applicable	<input type="checkbox"/> Previously Submitted, Date:	<input type="checkbox"/> Attachment
3. Detailed Description of Control Equipment (Required for all permit applications, except Title V air operation permit revision applications if this information was submitted to the department within the previous five years and would not be altered as a result of the revision being sought)	<input type="checkbox"/> Applicable	<input type="checkbox"/> Previously Submitted, Date:	<input type="checkbox"/> Attachment
4. Procedures for Startup and Shutdown (Required for all operation permit applications, except Title V air operation permit revision applications if this information was submitted to the department within the previous five years and would not be altered as a result of the revision being sought)	<input type="checkbox"/> Applicable	<input type="checkbox"/> Previously Submitted, Date:	<input type="checkbox"/> Attachment
5. Operation and Maintenance Plan (Required for all permit applications, except Title V air operation permit revision applications if this information was submitted to the department within the previous five years and would not be altered as a result of the revision being sought)	<input type="checkbox"/> Applicable	<input type="checkbox"/> Previously Submitted, Date:	<input type="checkbox"/> Attachment
6. Compliance Demonstration Reports/Records	<input type="checkbox"/> Applicable	<input type="checkbox"/> Previously Submitted, Date:	<input type="checkbox"/> Attachment
		<input type="checkbox"/> To Be Submitted, Date (if known):	
Previously Submitted Test Date(s)/Pollutants Tested:			
To be Submitted Test Date(s)/Pollutants Tested:			
Note: For FESOP applications, all required compliance demonstration records/reports must be submitted at the time of application. For Title V air operation permit applications, all required compliance demonstration reports/records must be submitted at the time of application, or a compliance plan must be submitted at the time of application.			
7. Other Information Required by Rule or Statute	<input type="checkbox"/> Applicable		<input type="checkbox"/> Attachment

Additional Requirements for Title V Air Operation Permit Applications

1. Identification of Applicable Requirements <input type="checkbox"/> Applicable	<input type="checkbox"/> Attachment
2. Compliance Assurance Monitoring Plan <input type="checkbox"/> Applicable	<input type="checkbox"/> Attachment
3. Alternative Methods of Operation <input type="checkbox"/> Applicable	<input type="checkbox"/> Attachment
4. Alternative Modes of Operation (Emissions Trading) <input type="checkbox"/> Applicable	<input type="checkbox"/> Attachment
5. Acid Rain Part Application	
Certificate of Representation (EPA Form No. 7610-1) <input type="checkbox"/> Applicable <input type="checkbox"/> Previously Submitted, Date:	<input type="checkbox"/> Attachment
Acid Rain Part (Form No. 62-210.900(1)(a)) <input type="checkbox"/> Applicable <input type="checkbox"/> Previously Submitted, Date:	<input type="checkbox"/> Attachment
Repowering Extension Plan (Form No. 62-210.900(1)(a)1.) <input type="checkbox"/> Applicable <input type="checkbox"/> Previously Submitted, Date:	<input type="checkbox"/> Attachment
New Unit Exemption (Form No. 62-210.900(1)(a)2.) <input type="checkbox"/> Applicable <input type="checkbox"/> Previously Submitted, Date:	<input type="checkbox"/> Attachment
Retired Unit Exemption (Form No. 62-210.900(1)(a)3.) <input type="checkbox"/> Applicable <input type="checkbox"/> Previously Submitted, Date:	<input type="checkbox"/> Attachment
Phase II NOx Compliance Plan (Form No. 62-210.900(1)(a)4.) <input type="checkbox"/> Applicable <input type="checkbox"/> Previously Submitted, Date:	<input type="checkbox"/> Attachment
Phase II NOx Averaging Plan (Form No. 62-210.900(1)(a)5.) <input type="checkbox"/> Applicable <input type="checkbox"/> Previously Submitted, Date:	<input type="checkbox"/> Attachment

Additional Requirements for Air Construction Permit Applications

- | | | |
|---|-------------------------------------|-------------------------------------|
| 1. Control Technology Review and Analysis (Rules 62-212.400(10) and 62-212.500(7), F.A.C.; 40 CFR 63.43(d) and (e)) | <input type="checkbox"/> Applicable | <input type="checkbox"/> Attachment |
| 2. Good Engineering Practice Stack Height Analysis (Rule 62-212.400(4)(d), F.A.C., and Rule 62-212.500(4)(f), F.A.C.) | <input type="checkbox"/> Applicable | <input type="checkbox"/> Attachment |
| 3. Description of Stack Sampling Facilities (Required for proposed new stack sampling facilities only) | <input type="checkbox"/> Applicable | <input type="checkbox"/> Attachment |

Other Information Regarding this Emissions Unit

- | | | |
|-------------------------------------|-------------------------------------|-------------------------------------|
| 1. Other Emissions Unit Information | <input type="checkbox"/> Applicable | <input type="checkbox"/> Attachment |
|-------------------------------------|-------------------------------------|-------------------------------------|
- Note: Provide any other information related to the emissions unit addressed in this Emissions Unit Information Section that is not elsewhere provided in the application, not otherwise required and that you, the applicant, believe may be helpful.

Additional Requirements Comment

This application seeks to properly designate this EU as a control device for the MSW landfill (EU-001)
--

APPLICATION: OKEECHOBEE AC & AV MODIFICATION FOR FLARES: PSD (#1270-2)
 FACILITY: OKEECHOBEE LANDFILL, INC. (#0930104)

Facility Attachments				
Supplemental Item	Electronic File Name	Attachment Description	Electronic Document?	Date Uploaded
ADDITIONAL IMPACT ANALYSES (RULES 62-212.400(8) and 62-212.500(4)(e), F.A.C.)	Additional Impact Analysis.doc	Please refer to Section 5.0 of the Air Quality Impact Assessment	Yes	2/28/2007
AIR QUALITY ANALYSIS (RULE 62-212.400(7), F.A.C.)	Air Qual Analysis.doc	Please refer to Section 4.2 of the Air Quality Impact Assessment	Yes	2/28/2007
AIR QUALITY IMPACT SINCE 1977 (RULE 62-212.400(4)(e), F.A.C.)	Air Qual 1977.doc	Please refer to Section 5.2 of Section III - Air Quality Impact Assessment	Yes	2/28/2007
AREA MAP SHOWING FACILITY LOCATION	Figure 1 - Facility Area Map.pdf	Figure 1 - Facility Area Map	Yes	2/28/2007
DESCRIPTION OF PROPOSED CONSTRUCTION, MODIFICATION, or PLANTWIDE APPLICABILITY LIMIT (PAL)	Description of proposed.doc	Please refer to Section 3.0 of the PSD Permit Application Support Documentation	Yes	2/28/2007
FACILITY PLOT PLAN	Figure 3 - Facility Plot Plan.pdf	Figure 3 - Plot Plan	Yes	2/28/2007
OTHER FACILITY INFORMATION	Air Construction PSD 02272007A.pdf	Cover Letter	Yes	2/28/2007
-->	Final AC-PSD Report 2007-02-27.pdf	PSD/AC Permit Application Support Documentation	Yes	2/28/2007
-->	TOC whole application + covers.pdf	Title Page/TOC	Yes	2/28/2007
PRECAUTIONS TO PREVENT EMISSIONS OF UNCONFINED PARTICULATE MATTER	Precautions to Prevent.doc	Please refer to Section 6.0 of the PSD Permit Application Support Documentation	Yes	2/28/2007
PROCESS FLOW DIAGRAM(s)	Figure 2 - Process Flow Diagram.pdf	Figure 2 - Process Flow Diagram	Yes	2/28/2007
RULE APPLICABILITY ANALYSIS	Rule Applicability Analysis.doc	Please refer to section 4.0 of the PSD Permit Application Support Documentation	Yes	2/28/2007
SOURCE IMPACT ANALYSIS (RULE 62-212.400(5), F.A.C.)	Air Quality Impact Analysis_OKI draft 02-26-2007ver01 resized.pdf	Section III - Air Quality Impact Assessment	Yes	2/28/2007

Emissions Unit Attachments

Emissions Unit: 001 - MSW Landfill with an active gas collection & control devices

Supplemental Item	Electronic File Name	Attachment Description	Electronic Document?	Date Uploaded
COMPLIANCE DEMONSTRATION REPORTS/RECORDS	Flare Testing Report 09252006.pdf	Recent compliance Demonstation Report	Yes	2/28/2007
CONTROL TECHNOLOGY REVIEW AND ANALYSIS (RULES 62-212.400 (10) and 62-212.500(7), F.A.C.; 40 CFR 63.43(d) and (e))	Section II Appendix D - BACT Analysis.pdf	Appendix D of the PSD Permit Application Support Documentation - BACT Evaluation Summary	Yes	2/28/2007
DESCRIPTION OF STACK	Section II Appendix G - Stack Parameters	Appendix G of PSD Permit Application Support Documentation - Description of Stack	Yes	2/28/2007

SAMPLING FACILITIES	and Sampling Facilities.pdf	Parameters & Sampling Facilities		
DETAILED DESCRIPTION OF CONTROL EQUIPMENT	Pages from Section II Appendix H - Control Equipment (part 2).pdf	Appendix H of the PSD Permit Application Support Documentation - Description of Control Equipment (part 2)	Yes	2/28/2007
-->	Section II Appendix H - Control Equipment (part 1).pdf	Appendix H of the PSD Permit Application Support Documentation - Description of Control Equipment (part 1)	Yes	2/28/2007
FUEL ANALYSIS OR SPECIFICATION	Section II Appendix C - Fuel Analysis.pdf	Appendix C of the PSD Permit Application Support Documentation - Fuel Analysis	Yes	2/28/2007
GOOD ENGINEERING PRACTICE STACK HEIGHT ANALYSIS (RULE 62-212.400(4)(d), F.A.C., and RULE 62-212.500(4)(f), F.A.C.)	Good Engineering.doc	Please refer to Section 3.4 of the Air Quality Impact Assessment	Yes	2/28/2007
OPERATION AND MAINTENANCE PLAN	O _ M Plan.doc	The O & M Plan for the landfill gas collection and treatment is comprised of several large binders, therefore it will not be submitted but maintained at the facility	Yes	2/28/2007
OTHER EMISSIONS UNIT INFORMATION	Section II Appendix A - General LF Operations.pdf	Appendix A - General MSW Process Description	Yes	2/28/2007
-->	Section II Appendix B - Support Calculations.pdf	Appendix B of the PSD Permit Application Support Documentation - Support Calculations	Yes	2/28/2007
-->	Section II Appendix E - LFG Generation n Construct Sched.pdf	Appendix E - LFG Generation Rates and Construction Schedule	Yes	2/28/2007
-->	Figure 4 - aerial landfill.pdf	Figure 4 - Aerial Depiction of Landfill Phases	Yes	2/28/2007
PROCEDURES FOR STARTUP AND SHUTDOWN	Section II Appendix F - Procedures for startup and shutdown.pdf	Appendix F of PSD Permit Application Support Documentation - Startup, Shutdown, and Malfunction Plan	Yes	2/28/2007
PROCESS FLOW DIAGRAM	Figure 2 - Process Flow Diagram.pdf	Figure 2 - Process Flow Diagram (same as facility Process Flow Diagram)	Yes	2/28/2007
Report Completed as of: 3/7/2007 10:57:25 AM				

Additional Impact Analysis (Rule 62-212.400(8) and 62-212.500(4)(e),F.A.C.)

**Please refer to Section 5.0 of
the Air Quality Impact Assessment**

Air Quality Analysis (Rule 62-212.400(7),F.A.C.)

**Please refer to Section 4.2 of Section III - Air Quality
Impact Assessment**

Air Quality Impact Since 1977 (Rule 62-212.400(4)(e),F.A.C.)

**Please refer to Section 5.2 of Section III - Air Quality
Impact Assessment**

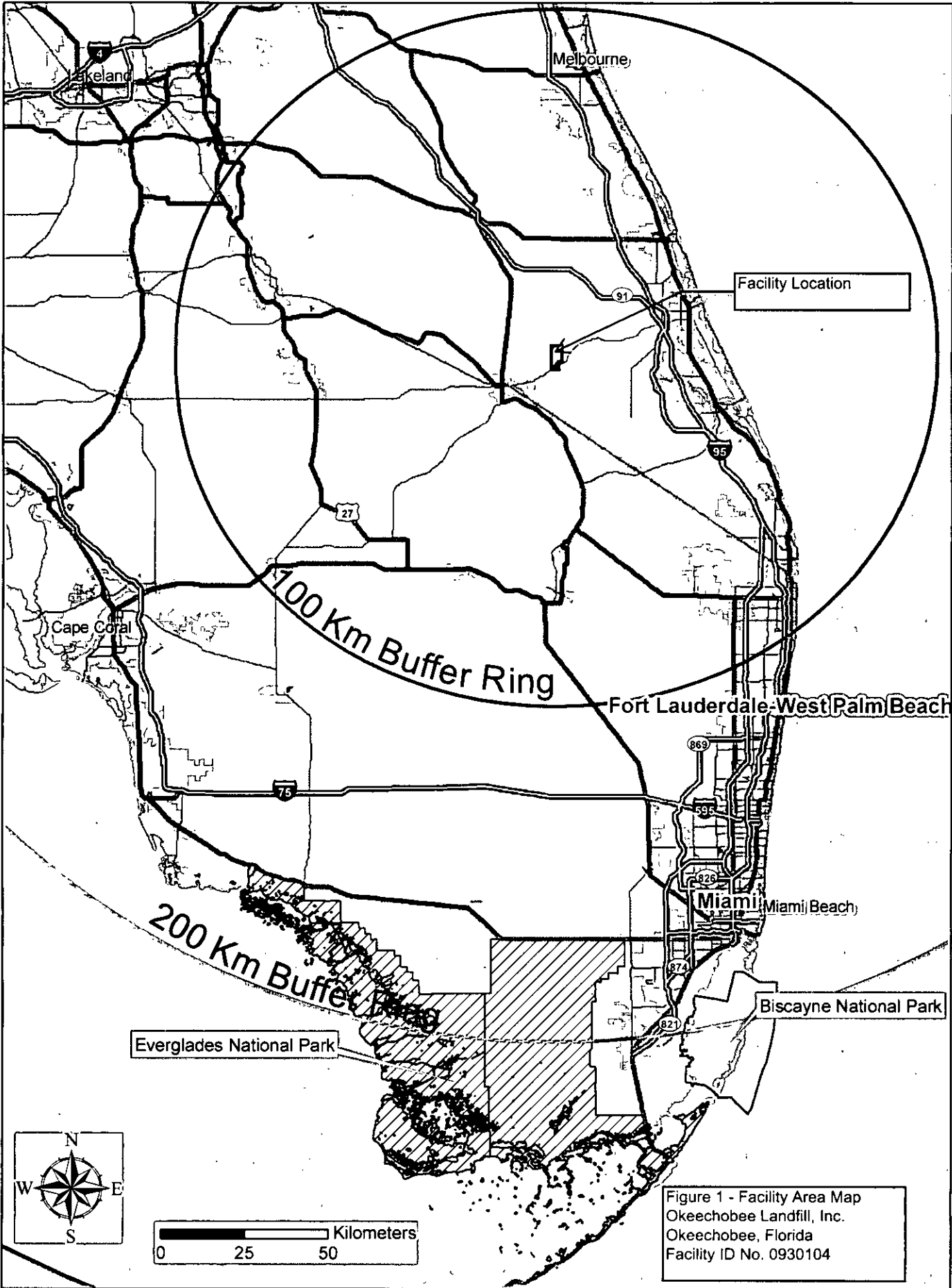

Facility Location

100 Km Buffer Ring

200 Km Buffer

Everglades National Park

Fort Lauderdale-West Palm Beach

Miami Miami Beach

Biscayne National Park

Figure 1 - Facility Area Map
 Okeechobee Landfill, Inc.
 Okeechobee, Florida
 Facility ID No. 0930104

Description of Proposed Construction, Modification, or Plantwide
Applicability Limit (PAL)

**Please refer to Section 3.0 of Section II – PSD/AC Permit
Application Support Documentation**

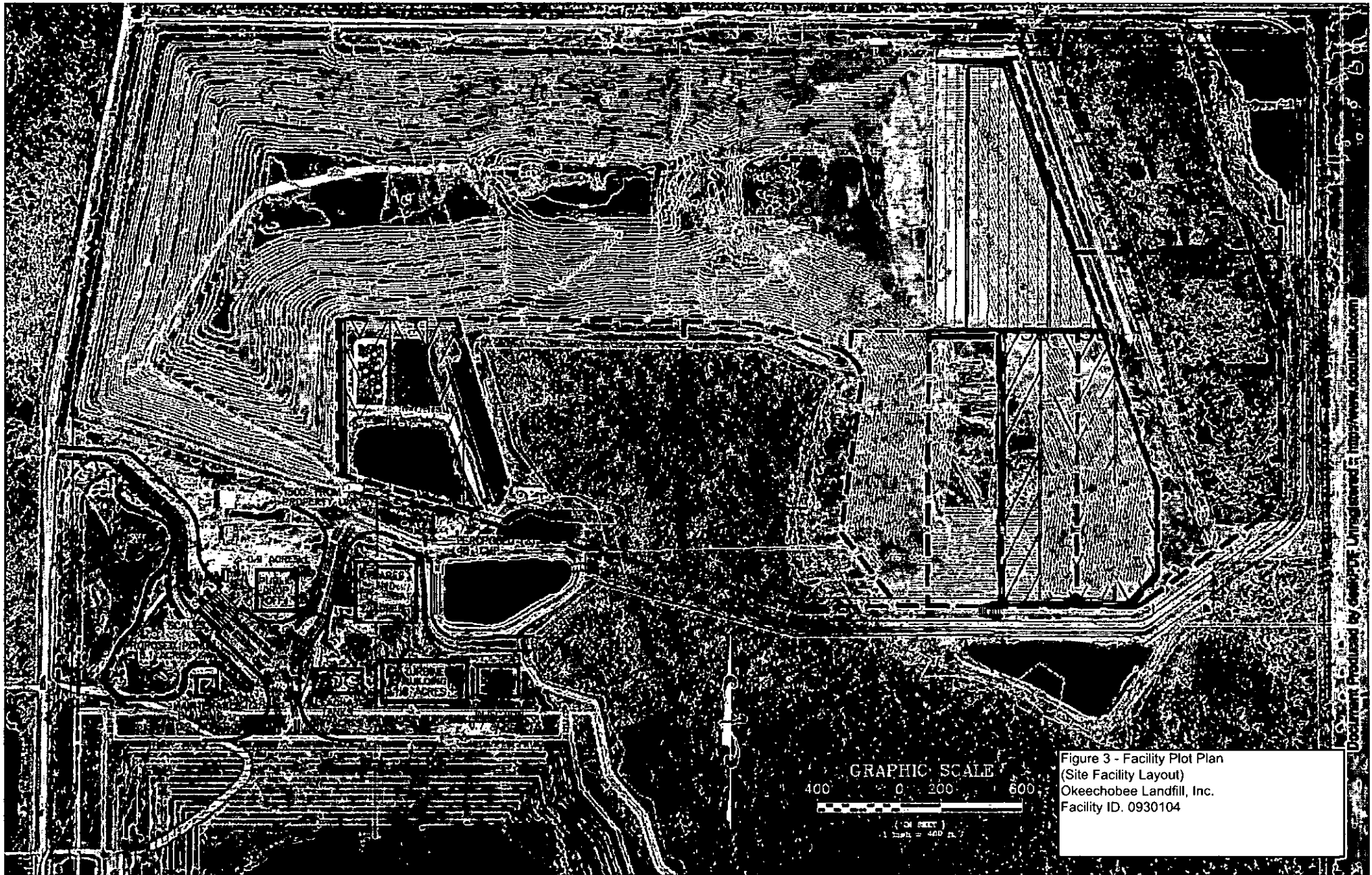

Figure 3 - Facility Plot Plan
(Site Facility Layout)
Okeechobee Landfill, Inc.
Facility ID: 0930104



OKEECHOBEE LANDFILL, INC.
A WASTE MANAGEMENT COMPANY

10800 NE 128th Ave.
Okeechobee, FL 34972
(863) 357-0111
(863) 357-0772 Fax

February 27, 2007

VIA EPSAP
(FDEP Permit Application Online Submittal Process)

Mr. Al A. Linero
Chief, Bureau of Air Regulation
Division of Air Resource Regulation
2600 Blair Stone Road MS# 5505
Tallahassee, FL 32399-2400

**Subject: Air Construction PSD Permit Application No. 1270-2
Okeechobee Landfill, Inc. Facility ID No. 0930104**

Dear Mr. Linero:

Okeechobee Landfill Inc. (OLI) has attached, through the EPSAP, the revised application for a modified construction air permit related to the construction of the Okeechobee Landfill. This application has been revised to address the issues identified in the following correspondence: (1) request for additional information from the Florida Department of Environmental Protection (FDEP) dated September 1, 2006; (2) letter from Scott Sheplak dated January 30, 2007; and (3) second Amended Order to the Settlement Agreement, OGC file 04-0094. Responses to the identified issues are also included in this cover letter. The application has also been revised to include the emissions from both phases (Berman Road and Clay Farms) of the landfill emission unit and the construction of additional flares and turbines, preceded by a desulphurization process to control emissions from the landfill. Turbines are the preferred method of control provided they continue to appear feasible.

Summary of Application

The first application (1270-1) was expeditiously submitted in accordance with the first Amended Order to the Settlement Agreement executed between Okeechobee Landfill, Inc. (OLI) and FDEP. The first Amended Order allowed the installation and operation of a landfill gas (LFG) flare to reduce odors and required that a permit application for the flare be submitted within 30 days of the Amended Order. On July 28, 2006, Application 1270-1 for the concurrent processing of a construction and Title V permit was submitted. That application also included another LFG flare and a LFG desulphurization system.

Since that application, review of the projected potential LFG generation suggests that turbines as part of a landfill gas to energy (LFGTE) plant may be economically feasible. Additionally, in light of the increased LFG actual production compared to estimates made earlier of the landfill gas production expected from the Berman Road and Clay Farms phases of the landfill, it was concluded that more LFG control devices would be required for the landfill construction and operation. During the period between the submittal of Application 1270-1 and this revised Application (1270-2), a second Amended Order has been executed that allows another flare (for a total of up to five flares) to be operated at the Facility for odor and NSPS controls.

Application 1270-2 proposes two operating scenarios: (1) the preferred operating condition would be to control LFG through up to seven (7) combustion turbines that are part of a landfill gas to energy plant and up to two (2) flares (one at partial flow) to control the balance of LFG and to control odors; (2) the alternative operating condition would consist of the addition of up to five LFG flares (in addition to the five (5) LFG flares currently authorized under the second Amended Order) for a total of ten (10) flares. Both operating scenarios would include installation and operation of a LFG desulphurization system.

This permit application is unique compared to typical PSD applications and projects. Typically, the PSD applications cover a new facility or a facility modification while still in the planning stages. In the planning stages, a project can be cancelled or located elsewhere if air emission complexities prevent it from being economically feasible. Additionally, there is typically less time constraint because the typical projects do not have increased emissions unless the project is implemented. In the case of the Okeechobee Landfill site, the emissions unit exists as an FDEP-permitted solid waste landfill and will have increasing LFG generation under the current permit. The Okeechobee Landfill site is an important part of the State of Florida's solid waste disposal capacity. The Facility has supported and is designated for natural disaster response efforts for accepting increased and specialized waste streams.

Response to Comments and Request for Information

Below are the comments from the FDEP letter dated September 1, 2006 for the Okeechobee Landfill, Inc. Facility (DEP File No. 0930104-014-AC).

Comment from FDEP Letter Paragraph 3 and 4:

"A description as to what system of continuous emissions reduction is planned and a best available control technology (BACT) proposal are needed in accordance with Paragraph 62-212.400(4)c, F.A.C. Also Source Impact Analysis, Air Quality Analysis, and Additional Impact Analyses are needed as described in Paragraphs 62-212.400(5), (7), (8) and possible (9), F.A.C. depending on effects upon the Class I Areas.

According to the information submitted, the emissions increases for the proposed projects will exceed the respective significant emissions rates for several pollutants. The key pollutant subject to PSD and that Shaw concentrated on sulfur dioxide (SO₂). It appears that emissions increase of nitrogen dioxide (NO_x), carbon monoxide (CO), and particulate matter (PM₁₀) also exceed their respective significant emissions rates. Therefore ambient analyses and a BACT proposal are required for the additional pollutants."

Response: The BACT analysis has been completed for SO₂, NO_x, CO, and PM₁₀ and is included in Appendix D of the PSD Air Construction Permit Application Support Documentation. Section III of the Application includes the Air Quality Impact Analysis for SO₂, NO_x, CO and PM₁₀.

Request for Information Letter from Scott M. Sheplak of the FDEP, dated January 30, 2007

Paragraph 2, last sentence: *"In your additional information response, please include a detailed description of the basis for the PTE of the proposed project. Include pertinent supporting information like: i) the dependent values relied upon for the landfill's capacity, e.g. design quantity of solid waste in tons and in cubic yards; ii) an aerial photograph clearly showing the footprint of the current and expanded landfill site; and, iii) how long will it take for the landfill to reach the requested capacity in years."*

The Application support document found in Section II, "Prevention of Significant Deterioration (PSD) Air Construction (AC) Permit Application Support Document", provides this information. Specifically, the PTE basis is described in Section 3.3.1 of the Document, the aerial photograph is Figure 4, and the construction duration for the landfill to reach capacity is also included in Section 3.3.1 and detailed in Appendix E.

Ordered from Second Amended Order:

Part 6, subsection xi. *"Within 60 days of the effective date of this Second Amended Order, Respondent shall submit a revised PSD permit application addressing the temporary flare(s) and the use of the back-up flare. The PSD permit application shall be accompanied by a compliance plan for the installation of the final control system."*

Response: SECOND AMENDED ORDER TO THE SETTLEMENT AGREEMENT COMPLIANCE STATUS

The Second Amended Order added six orders to the Original Order; they are listed below with a summary of the Facilities current compliance status.

6.viii. *Allowed the Respondent, Okeechobee Landfill, Inc (OLI) to continue to operate the existing temporary odor control flare and granted authority to install and operate one additional temporary odor control flare as necessary to control odor. The number of operating flares at the Facility shall not exceed five in operation at any one time. All the temporary flares shall be connected to a LFG collection system that meets the provisions of 40 CFR 60, subpart www and 40 CFR subpart AAAA. The temporary flares shall only burn LFG collected through the odor control wells. The Respondent (Facility) shall maintain a record of 1) the dates odor control wells are installed, 2) the total amount of gas collected from these wells, and 3) the amount of gas burned in the temporary flare(s).*

At the time of this Application filing, OLI is operating three flares. The odor control flare is connected to a collection system that meets the cited rules. Records are being collected and maintained on site. Copies may be provided at the Department's request.

6.ix. *The existing backup flare may be used as a temporary odor control device.*

At the time of this Application filing, OLI is not operating the existing backup flare to control odor. If the flare is operated it will be in accordance with the provisions of 40 CFR 60 Subpart www and 40 CFR 63 Subpart AAAA. Records as required for the temporary flares, Part 6.viii, will be collected and maintained on site.

6.x. *The existing temporary flare and the existing backup flare shall be tested per 40 CFR Part 60.18 for flares within 60 days of the effective date of the Second Amended Order.*

The flares will be tested for visible emissions, EPA Method 9, on or before March 22, 2007.

6.xi. *Within 60 days of the effective date of the Second Amended Order, the Respondent must submit a revised PSD permit application addressing the temporary flare(s) and the use of the existing backup flare. A compliance plan for the installation of the final control system must accompany the application.*

This compliance status and plan are accompanying the PSD air construction permit application. The Application is being submitted through the EPSAP system. A compliance plan is provided below.

6.xii. *Does not include an order that requires compliance action by the Respondent.*

6.xiii. *Does not include an order that requires a compliance action by the Respondent.*

6.xiv. *Effective June 30, 2007, the OLI will test the LFG for H₂S and total flow rates sent to the landfill flares. This data will be used to determine the tons of SO₂ emitted. For each ton emitted the OLI will pay a fee of \$25.00.*

This Order will be implemented on June 30, 2007.

COMPLIANCE PLAN FOR THE INSTALLATION OF THE FINAL CONTROL SYSTEM

1. As stated in the PSD/AC Permit Application 1270-2, the design, procurement, installation, and system proveout for the LFG desulphurization system would be completed in approximately 24 months from the issuance of the permit. The schedule presented in the Application provides approximately one year for the air permit process. The schedule assumes the proveout period would not be greater than two weeks.
2. The same process for the turbines operation is expected to begin during the same period, however, the approval process may take longer.

A construction schedule has been included in Appendix E of the PSD/AC Support Document. The basis of the schedule is the LFG generation rate model, which is also provided in Appendix

Mr. Al Linero
FDEP Division of Air Resource Regulation
Permit Application No. 1270-2, 0930104

E. The construction schedule shows the yearly incremental LFG rate increase and the control device installation schedule for both operating scenarios: flares and turbines.

If you have any questions or requests for additional information, the contacts are provided in the Application or you may contact OLI's Compliance Representative for this permit, Mr. David Thorley at 713-328-7404 or dthorley@wm.com or Michele Lersch at 813-786-6807 or mlersch@wm.com.

Respectfully submitted,



Mike Stallard
Director, Landfill Operations

CC: John Van Gessel, Okeechobee Landfill, Inc.'s Authorized Representative
Kristin Alzheimer, P.E, Shaw Environmental & Infrastructure, Inc.

SECTION II

Prevention of Significant Deterioration (PSD) Air Construction (AC) Permit Application Support Documentation

**No. 1270-2
Facility No. 0930104
Okeechobee Landfill
(Formerly Berman Road Landfill)
Okeechobee, Florida**

**Prepared for:
Okeechobee Landfill, Inc.
10800 N.E. 128th Avenue
Okeechobee, FL 34972
(863) 357-0111**

Prepared by:



**Shaw Environmental and Infrastructure, Inc.
88C Elm Street
Hopkinton, MA 01748**

Submitted to:

**Florida Department of Environmental Protection
Air Resource Management
2600 Blair Stone Road MS 5500
Tallahassee, Florida 32399-2400**

February 27, 2007

Table of Contents

1.0	INTRODUCTION AND OVERVIEW.....	1
2.0	FACILITY HISTORY AND OPERATIONS OVERVIEW.....	2
2.1	Existing Operating Conditions.....	3
2.2	Permit History.....	3
2.3	Current Compliance Status.....	4
2.4	Baseline Actual Emissions.....	4
3.0	DESCRIPTION OF THE CONSTRUCTION PROJECT.....	5
3.1	Project Necessity.....	5
3.2	Proposed Project Permit Modifications.....	6
3.3	Construction Project Conditions.....	6
3.3.1	Landfill Construction, Process Flow and Emission Control Devices.....	6
3.3.2	Project Operating Conditions.....	8
A.	Interim Pre-BACT Operating Scenario (<i>Informational Purposes Only</i>).....	8
B.	Post-BACT Operating Scenario.....	8
C.	Startup, Shutdown, Maintenance and Malfunctions.....	9
3.4	Construction Schedule.....	9
3.5	Proposed Source Emissions and Site Layout.....	10
3.6	Stack Sampling Facilities.....	10
4.0	RULE APPLICABILITY ANALYSIS.....	11
4.1	General Rule Applicability.....	11
4.2	New Source Performance Standards (NSPS).....	11
4.2.1	40 CFR 60, Subpart WWW, MSW Landfills.....	11
4.2.2	40 CFR 60, Subpart KKKK Stationary Combustion Turbines.....	11
4.3	National Emissions Standards for Hazardous Air Pollutants (NESHAPS).....	11
4.3.1	40 CFR 63, General Provisions; Subpart A General Provisions.....	11
4.3.2	40 CFR 63, General Provisions; Subpart AAAA Municipal Waste Landfills.....	11
4.4	Florida Administrative Code (F.A.C.).....	11
4.4.1	Chapter 62-4.....	11
4.4.2	Chapter 62-204 Air Pollution Control – General Provisions.....	12
4.4.3	Chapter 62-210 Stationary Sources – General Requirements.....	12
4.4.4	Chapter 62-212 Stationary Sources – Preconstruction Review.....	12
5.0	PRECONSTRUCTION REVIEW [f.a.c. 62-212].....	12
5.1	Prevention of Significant Deterioration (PSD) Process [F.A.C. 62-212.400].....	12
5.1.2	Source Emissions and PSD Emission Rate Triggers.....	13
5.2	Control Technology Review [F.A.C. 62-212.400(4)(c) and (10)].....	14
5.3	Details of Proposed Control Technologies.....	15
5.3.1	Control of NMOC and HAPs.....	15
5.3.2	Control of SO ₂	15
5.4	Summary of the Ambient Air Quality Impact Analysis.....	16
5.4.1	Source Impact Analysis [F.A.C. 62-212.400(5)].....	16
5.4.2	Air Quality Analysis [F.A.C. 62-212.400(7)].....	16
5.4.3	Air Quality Impact Since 1977 [F.A.C. 62-212.400(4)(e)].....	16
5.4.4	Additional Impact Analyses [F.A.C. 62-212.400(8)].....	16
6.0	PRECAUTIONS TO PREVENT.....	17

Tables
 Figures
 Appendices

Abbreviations, Acronyms, and Initialisms

AP-42	Compilation of Air Pollution Emission Factors (USEPA)
Application	Construction Permit Application 1270-2 for Okeechobee Landfill, Inc.
AQIA	Air Quality Impact Analysis
ascfm	actual standard cubic feet per minute
BACT	Best Available Control Technology
CD	control device
CFR	Code of Federal Regulations
CO	Carbon Monoxide
dscfm	dry standard cubic feet per minute
EU	Emission Unit
F.A.C.	Florida Administrative Code
Facility	Okeechobee Landfill, Inc, landfill facility
FDEP	Florida Department of Environmental Protection
FLM	Federal Land Managers
HAP	Hazardous Air Pollutant
H ₂ S	Hydrogen Sulfide
lb/hr	pounds per hour
LFG	Landfill gas
LFGTE	Landfill gas to energy
MSW	Municipal Solid Waste
NMOC	Nonmethane Organic Compounds
NO ₂	Nitrogen Dioxide
NO _x	Nitrogen Oxides
OLI	Okeechobee Landfill, Inc.
PCP	pollution control project
PCR	Preconstruction Review
PM	particulate matter
PSD	Prevention of Significant Deterioration
PTE	potential to emit
scfm	standard cubic feet per minute
SIL	Significant Impact Level
SO ₂	Sulfur Dioxide
TPY	tons per year
USEPA	United States Environmental Protection Agency
VOC	Volatile Organic Compounds

1.0 INTRODUCTION AND OVERVIEW

The Okeechobee Landfill Facility (the Facility), which is owned and operated by Okeechobee Landfill, Inc. (OLI), is comprised of an existing municipal solid waste (MSW) landfill and supporting operations. The facility has been operational since 1981 and under the existing solid waste permits would continue to construct and operate the landfill until approximately 2058. This Air Construction Permit Application No. 1270-2 (the Application) has been developed to support the continued construction of the MSW landfill (the Project). The landfill is an emission unit for nonmethane organic compounds (NMOCs), a landfill gas (LFG) constituent. The typical control device (CD) for NMOCs in LFG is flaring. Other destructive control devices that are sometimes used for LFG combustion are turbines, engines, enclosed combustors, and boilers. The proposed modification to the landfill includes increasing flaring capacity, adding sulfur removal equipment, and constructing a landfill-gas-to-energy (LFGTE) plant.

The Application seeks to modify the following previously-submitted construction permit applications:

- 0930104-001-AC related to the MSW landfill, and
- 0930104-003-AC, 0930104-004-AC, 0930104-005-AC, 0930104-007-AC, 0930104-008-AC, 0930104-009-AC, 0930104-010-AC related to the three existing LFG flares.

Although the Facility is not permitted as a major stationary source, recent fuel analysis for hydrogen sulfide (H_2S) indicates that the actual emissions do qualify the Facility as a major stationary source for sulfur dioxide (SO_2) a Prevention of Significant Deterioration (PSD) pollutant. Additionally, the expected emission increases for the modification are above the significant emission increase for nitrogen dioxide (NO_2), carbon monoxide (CO), and particulate matter (PM_{10}), therefore PSD is applicable. The Application provides the information required by Chapter 62-212.400, F.A.C., for PSD.

Best Available Control Technology Analysis (BACT) for SO_2 would be a LFG desulphurization system installed to pretreat the LFG in conjunction with the destructive control devices. After the installation of the desulphurization equipment, modeling analysis indicate the following results:

- The ambient air quality impacts were less than both the current and proposed the Class I significance level concentrations. Thus, Class I PSD increment analysis was not required.
- The total nitrogen and total sulfate depositions for all years were lower than the NPS deposition analysis threshold (DAT) of 0.01 Kg/ha-yr
- The visibility impairment was less than 5 percent of the background in all 24-hour periods in 2001, 2002, and 2003.
- The construction project would have negligible effects on regional growth, visibility in Class I Areas, and vegetation and soils in the project area.

Briefly, the Application consists of modifying the existing construction permits to reflect the proposed project. The proposed changes are summarized in the list below.

1. The construction permit for the existing landfill emission unit (EU-001) would be updated to include the revised estimated potential to emit (PTE) for the completed landfill under its current valid solid waste construction permit(s).

2. The construction permit EU-001 would be revised to reflect the nature and extent of the proposed air emission control devices (fuel desulphurization, turbines and flares).
3. The construction permits for the flares would be considered invalid so that the emission units (EU -003, EU -004 and EU-005) would be correctly designated as valid control devices for EU-001;
4. The construction permit for EU-001 would provide the relocation of the two existing enclosed LFG flares to the proposed central flaring device area.
5. The fuel analysis data for sulfide content that significantly differs from the EPA AP-42 default data for LFG used in past applications would be updated as would the future potential emissions for the proposed construction modification project.

The Application is comprised of the following sections:

- Section I – Air Construction Permit Application (Long Form)
- Section II - Prevention of Significant Deterioration (PSD) Air Construction (AC) Permit Application Support Documentation (the Report)
 - Section 1.0 – Introduction and Overview
 - Section 2.0 - Facility History and Operations Overview
 - Section 3.0 - Description of the Construction Project
 - Section 4.0 - Rule Applicability Analysis
 - Section 5.0 - Preconstruction Review
 - Section 6.0 – Precautions to Prevent Emission of Unconfined Particulate Matter
- Section III - Air Quality Impact Analysis for Proposed Modification Construction (AQIA)

2.0 FACILITY HISTORY AND OPERATIONS OVERVIEW

The OLI facility is located in Okeechobee County of south central Florida. **Figure 1** is an area map of the Facility. The landfill was established at 10800 N.E. 128th Avenue in 1981 under a solid waste operating permit. The permit allowed for the construction and operation of a MSW landfill called the Berman Road landfill. Today, the Facility has a second solid waste permit for another phase in construction. The landfill phase currently under construction is designated as the Berman Road Landfill and the future landfill phase is designated as the Clay Farms Landfill. The Facility is a single stationary source consisting of a single emission unit; the MSW landfill.

The Facility receives waste from various parts of the State of Florida and is an integral part of the State's solid waste disposal capacity. The landfill receives municipal solid waste, construction and demolition material and special wastes over scales at the entrance to the landfill. Trucks are directed to the operating face of the landfill for the actual disposal. The waste is compacted and covered daily. Liquids from the landfill are collected and disposed on site in LFG-fired evaporation units or trucked off site. Currently, LFG is collected in a system designed to capture gas from appropriate areas of the landfill, then the gas is flared. For a more general description of landfill construction and operation, please refer to **Appendix A**.

The facility operates odor control flare(s) under Settlement Agreement OGC File No. 04-0094 (Settlement Agreement) executed in March 2005. The facility has operated in

compliance with the FDEP rules except for occasional odor issues associated with the waste disposal business which the landfill addresses on a continuing basis. The flaring portion of the project is an integral part of the continued odor control process.

2.1 Existing Operating Conditions

The landfill currently has over 12,275,000 Megagrams (Mg) (13,500,000 tons) of waste in place. Two enclosed landfill gas flares with Evap® systems and an open, utility flare as a backup are used to control potential landfill emissions. The two enclosed flares and the backup flare are operated under the current Title V operation permit. There is currently an odor control flare that is operating under a First Amended Order to the Settlement Agreement executed between Florida Department of Environmental Protection (FDEP) and OLI on June 28, 2006. A Second Amended Order was implemented on January 7, 2007 and allows for up to five flares to be operated at the facility.

2.2 Permit History

The following table from the most recent air permit summarizes the permitting history.

EU ID No.	Description	Permit No.	Effective Date	Expiration Date	Project Type ¹
001	Landfill	0930104-001-AC	05/13/1997	05/12/1998	Construction
001	Landfill	0930104-002-AV	12/16/1997	12/15/2002	Initial TV
002	Enclosed Flare (1500 SCFM)	0930104-003-AC	05/01/1998	05/12/1999	Construction Extension
002 & 003	1500 scfm enclosed flare 3000 scfm enclosed flare	0930104-004-AC	07/23/2001	07/22/2002	Construction
002 & 003	1500 scfm enclosed flare 3000 scfm enclosed flare	0930104-005-AC	05/22/2002	11/19/2002	Construction Extension
001, 002, 003, 004	Landfill, 1500 scfm enclosed flare, 3000 scfm enclosed flare, 3000 scfm open flare	0930104-006-AV	08/08/03	08/02/2008	TV Renewal
004	3000 scfm open flare	0930104-007-AC	04/15/2003	04/14/2004	Construction
002 & 003	1500 scfm enclosed flare 3000 scfm enclosed flare	0930104-008-AC	09/24/2002	02/17/2003	Construction (Ext.)
002 & 003	1500 scfm enclosed flare 3000 scfm enclosed flare	0930104-009-AC	01/28/2003	03/19/2003	Construction (Ext.)
005	3000 scfm enclosed flare	0930104-010-AC	09/29/2003	09/28/2004	Construction

The following is the facility description from the existing Title V permit issued by FDEP:

This facility consists of a municipal solid waste landfill, a 3,000 scfm Enclosed flare Unit # 1776 with an EVAP Unit # 3016, a 3,000 scfm Enclosed flare Unit # 1698 with a leachate EVAP Unit 3004IM and a 3,000 scfm unenclosed (Utility) flare Unit 1495, as a back-up unit. The backup flare operates when one or more enclosed flares are not operating due to malfunction or maintenance and it will operate at the same capacity of the flare that is shut down. (The existing 3,000 scfm flare has a capacity of up to 3,300 scfm according to the manufacturer's specification sheet.)

This facility does not operate a bioreactor.

Also included in this permit are miscellaneous unregulated/insignificant emission units and/or activities.

*Based on the initial Title V air operating permit application received March 11, 1997 and the Title V air operation permit revision application received **March 26, 2003**, this facility is a major source of hazardous air pollutants (HAPs).*

The current operation permit lists the following emission units:

EU ID No.	Brief Description
001	A Municipal Solid Waste Landfill
003	A 3,000 scfm Enclosed flare Unit # 1776 with EVAP Unit #3016
004	A 3,000 scfm Unenclosed Flare Unit # 1495, used as a back-up unit
005	A 3,000 scfm Enclosed flare Unit # 1698 with a leachate EVAP® Unit # 3004IM.

As discussed in **Sections 1.0 and 3.2**, emission units 003, 004 and 005 would be designated as control devices for E U-001

2.3 Current Compliance Status

For the purposes of this section that addresses compliance demonstration with the current Title V operating permit, the four existing EU designations are used.

EU-001 – Municipal Waste Landfill: Semi-annual compliance reports for this facility are filed in accordance with FDEP and Federal air rules. The Facility has been the subject of discussions about compliance with FDEP. The Facility saw a significant jump in LFG generation in 2003 and 2004 that outpaced the flare capacity. The Settlement Agreement of March 2005 was implemented to control odors. In June 2006, a First Amended Order addressed control of landfill gas through the use of a temporary flare and odor control wells. A Second Amended Order was issued in January 2007 that allows operation of up to five flares for odor control and NSPS control. At the time of this filing, the Facility operates (3) flares. There is no issue of noncompliance at the time of this filing.

EU-003 and EU-005 - Enclosed 3,000-scfm flare with EVAP® systems (renamed as CD-001 and CD-002 in the Application): The flares were tested in August 2006 for CO and demonstrated that the flares are in compliance. There is no issue of non-compliance at the time of this filing. The most recent compliance demonstration testing was performed in August 2006 and the report was filed in September 2006. There is no issue of noncompliance at the time of this filing.

EU-004 Utility Backup 3,000-scfm flare (renamed as CD-003 in the Application): EU-004 is an existing landfill gas utility flare currently operated as a backup flare. Under the recent Second Amended Order to the Settlement Agreement, the flare may be operated as an odor control flare or as a control device for the collected LFG. There is no issue of non-compliance at the time of this filing.

2.4 Baseline Actual Emissions

For an existing emissions unit, baseline actual emissions mean the average rate, in tons per year (TPY), at which the emissions unit actually emitted the pollutant during any consecutive 24-month period within the previous 10-year period. The two-year period for most MSW landfills would be the most recent emissions data for each criteria pollutant because emissions may increase with the steady deposition of waste. The highest 24-month average baseline actual emissions presented in table below were derived from average monthly LFG flow rate data for February 1, 2005 through January 31, 2007.

Baseline data and the supporting calculations are presented in **Appendix B** for the four existing air emission control devices: two enclosed flares with Evap® units, one utility flare used as a backup, and an odor control flare.

Table 1 – Estimated Actual Emissions

Pollutant	Baseline Actual Emissions
Sulfur Dioxide (TPY)	1,209
Nitrogen Dioxide (TPY)	34
Carbon Monoxide (TPY)	120
NMOCs (TPY)	3.4
Volatile Organic Compounds (TPY)	1.4
Particulate Matter PM ₁₀ (TPY)	8.9
Hydrogen Sulfide (TPY)	0.7
HAPs (Total) (TPY)	5.7
HAPs (Single) (TPY)	5.0

This Application addresses a modification related to the recent fuel analysis data because the sulfide content significantly differs from the Environmental Protection Agency's (EPA) air pollutant emission factors (AP-42) default data for landfill gas. Table 2.4-1, *Default Concentrations for LFG Constituents*, lists H₂S as 35.5 parts per million by volume (ppmv). At this concentration the SO₂ emission estimates are less than 13 TPY, well under the 250TPY that would have made PSD applicable. The current Title V operating permit has no allowable emissions or emission limits for SO₂. In 2005, a sample of landfill gas was collected and analyzed for sulfides. The H₂S results of that analysis indicated that the concentration of H₂S in the landfill gas is 5,800 ppmv to produce approximately 352 lb/hr and 1,543 TPY. **Appendix C** presents the typical fuel analysis for landfill gas.

In late 2005, an electronic application for concurrent processing of a construction and Title V operating permit for an additional LFG Flare was submitted to FDEP. The 2005 application included the higher emission estimates for the SO₂, but under the pollution control project (PCP) exemption, PSD was not applicable. Ultimately, it was decided that a PSD application was appropriate and OLI withdrew the submission.

Since the Facility does not belong to one of the 28 stationary source categories that is a major stationary source if it emits more than 100 TPY of a PSD pollutant, the Facility must emit more than 250 TPY of any PSD pollutant to be considered major. Based on the baseline actual emissions, the landfill is currently a major stationary source for SO₂. Additional analysis for applicable regulations is presented in **Section 4.0**.

3.0 DESCRIPTION OF THE CONSTRUCTION PROJECT

3.1 Project Necessity

As stated earlier in this Report, the facility receives waste from various parts of the State of Florida and is an integral part of the State's solid waste disposal capacity. The Project would allow the Facility to continue to fulfill a need for sanitary services by providing a regulated area to deposit MSW. Given the Facility's ability to handle a high waste stream rate and the large capacity, the landfill could be used for disposal in emergency response actions such

as hurricane cleanup, state or national disaster response, government waste disposal contingencies, and animal epidemic control and response measures (mass animal carcass disposal), among other situations not readily identified.

A permit to operate the existing and proposed CDs would assure the adequate destruction of LFG from current and future waste decomposition. The capacity of the existing flares is approaching its maximum operational and permitted limits and is insufficient to address increased gas generation as the permitted landfill area is filled. The project is necessary to meet the requirements of NSPS Subpart WWW, which requires 98-percent control efficiency of NMOC or reduce NMOC concentrations to 20 ppmv (dry basis as hexane at 3-percent oxygen), and NESHAP Subpart AAAA, which requires the operation of a control device for HAPs. Additionally, per the First and Second Amended Order requirements, the Applicant agrees to operate up to five utility flares to control odors.

3.2 Proposed Project Permit Modifications

As presented in Section 2.1 of this Report, the current Title V operating permit is comprised of four emission units; the MSW landfill, two enclosed flares, and the backup flare. The Application seeks to modify the following previously-submitted construction permit applications:

- 0930104-001-AC related to the MSW landfill, and
- 0930104-003-AC, 0930104-004-AC, 0930104-005-AC, 0930104-007-AC, 0930104-008-AC, 0930104-009-AC, 0930104-010-AC related to the three existing LFG flares.

As part of the requested construction permit, the Application would modify the existing designation of the flares as emission units to control devices. The MSW landfill emission unit would indicate that the control device for the pollutant NMOC is a flare. The construction project described in the next section would seek to further modify the landfill emission unit by proposing new control devices. The proposed construction and operating permit would have one emission unit as follows:

EU ID No.	Brief Description	Control Device
001	A Municipal Solid Waste Landfill <i>with an active landfill gas collection system and associated control devices</i>	Destructive (Flaring or LFG Turbines) and Non-Destructive (Desulphurization LFG Pretreatment)

3.3 Construction Project Conditions

3.3.1 Landfill Construction, Process Flow and Emission Control Devices

The construction project consists of a 129,507,735 Mg landfill: the Berman Road Landfill phase currently being constructed under solid waste construction permit 0040842-010-SC and the subsequent Clay Farm Landfill phase that will be constructed under solid waste construction permit 0247963-001-SC. To date, approximately 10-percent of the landfill construction has been completed for an estimated total of 12,275,000 Mg of waste in place. The estimated schedule for the completion of construction and concurrent operation of the landfill would be approximately 51 years from the present; in the year 2058. The planned construction of the landfill requires emission control devices for the NMOC and HAPs

constituents of LFG. **Figure 2** presents the process flow diagram which are identical for the Facility and EU-001.

To estimate the quantity and capacity of control devices, Carlson Engineering LLC (Carlson) used a first-order landfill gas generation model to estimate the yearly increased and the maximum LFG generation rate. One year after closure the LFG recovery rate would be at its maximum; this is roughly 30,200 scfm. (This number should not be confused with the control device potential to emit (PTE) for the project, which is 32,400 scfm. The basis for the PTE is explained in the paragraphs below). The year after closure, the LFG generation rate quickly decreases. The Application for the landfill construction project includes the number of control devices that would handle this flow rate or throughput at the maximum and, more importantly, to match the incremental increases predicted for the landfill operation during the construction. Since the turbines and flares have upper and lower throughput limits, they would be installed as the actual landfill gas generation rate requires their necessity. Additionally, flares would be installed and operated to fulfill the requirement to control odors.

It is estimated that to complete the construction project the following additional control devices would be needed:

- up to seven LFG flares (if turbines are installed, then the backup flare would be operated as a regular control device)
- up to seven turbines
- a desulphurization process

At 3,300 scfm per flare, seven additional flares with the existing flares would provide 32,400 scfm, enough capacity for the expected maximum LFG generation and for odor control.

LFG utility flares with an operating capacity of 3,300 scfm were chosen because they can be easily turned down when gas production starts to decrease and require a smaller amount of the available LFG used by the existing CDs when first brought on line.

During the same period of construction and operation, up to seven turbines may be installed. Mars 100 LFG turbines are anticipated for the project. These turbines have an estimated rating of 10 Megawatt (MW), which has been estimated to be a maximum fuel throughput of 4,000 scfm at 100 percent load. Seven turbines theoretically provide a total maximum throughput capacity of 28,000 scfm. The remaining 4,400 scfm of LFG generated by the landfill would be flared through two of the proposed utility flares. Below is an outline summary of the destructive control devices and their maximum potential to emit.

Current Capacity:

Enclosed Flares (3000-scfm each)	Utility Flare (3300 scfm each)	Total PTE (scfm LFG)
2	3	15,900

Estimated Maximum LFG Recovery : 30,200 scfm (from Carlson Engineering, LLC.)

Proposed Control Device Capacity:

Scenario 1	Turbines (4000 scfm each)	Utility Flares (3300 scfm each)	Total PTE (scfm LFG)
	7	1 and 1 at 33% capacity	32,400
Scenario 2	Enclosed Flares (3000-scfm each)	Utility Flare (3300 scfm each)	Total PTE (scfm LFG)
	2	8	32,400

The flares and turbines are destructive control devices installed to aid in the control of NMOCs and HAPs. By combusting the gas, the control devices produce other air pollutants, namely, CO, NO₂, PM₁₀, and SO₂. A BACT evaluation was completed for these air pollutants and a desulphurization system was selected to decrease SO₂ emissions. The summary of the BACT Evaluation is presented in **Section 5.2** and the full report is found in **Appendix D**.

3.3.2 Project Operating Conditions

A. Interim Pre-BACT Operating Scenario (*Informational Purposes Only*)

The interim operating scenario is not being permitted. This section is included to support FDEP's request that an Air Quality Impact Analysis be provided.

The LFG would continue to be collected and flared. Additional flares would be added as the LFG increases during the landfill construction. During this interim operating period, construction of the desulphurization system would commence. The desulphurization unit(s) would be procured, designed, constructed and installed at the facility. During this same period, the necessary approvals and permits would be sought for the power plant construction; a detailed design of the power plant would be developed; and procurement and construction would be completed. The implementation of the desulphurization unit(s) is expected to be approximately 24 months from the approval of the construction permit. The construction schedule is presented in **Appendix E**.

During a pre-application meeting with FDEP in Tallahassee it was requested that air modeling be reviewed for the interim operating scenario (pre-BACT). The approach for the interim operating capacity considered the timeframe to implement the BACT and the estimated LFG generation. The BACT implementation period, or approximately 36 months including the permitting process, was estimated to be late in the year 2009. Yearly LFG generation estimates prepared by Carlson Engineering suggest that 9,302 scfm would be collected during the early installation of a collection system and, with 100 percent recovery; it could be as high as 11,628 scfm. (Copies of the estimates are presented in **Appendix E**.) With the additional of an odor control flare, an additional 3,300 scfm could be available for a total of 14,928 scfm. Five flares would have the capacity to serve as control for this estimated gas collection. The Second Amended Order between FDEP southeast district and the Applicant allows up to five flares to operate at the Facility.

The maximum PTE for five flares is based on two existing enclosed flares at 3,000 scfm each, the backup utility flare (which may also be used for odor control), the existing odor control flare at 3,300-scfm, and one additional utility flares at 3,300 scfm. A total fuel throughput of 15,900 scfm has been used for the modeling of the interim operating scenario. Emissions and air model results are presented in the AQIA.

B. Post-BACT Operating Scenario

As the LFG desulphurization system and turbines are brought on line, the LFG would be redirected to the turbines. Emissions and air modeling scenarios were developed for two operating scenarios were developed for the Application. These two operating scenarios would present the maximum PTE and the associated pollutants for the two types of destructive control devices; turbines and flares. Both scenarios would include the selected BACT. The preferred or standard operating scenario would direct all LFG to the power plant

turbines for electricity production. However, odor control flaring may still be necessary until the landfill's closure. This scenario would have the maximum potential to emit based on seven turbines, one utility flare at full capacity, and a second utility flare operated at 33 percent capacity. This limit on the second flare is selected so that the total maximum throughput of LFG for the standard operating scenario is equal to the alternative operating scenario. The maximum LFG throughput is 32,400 scfm. Details on the proposed control devices and the emissions are presented in **Section 3.5** and **5.2**.

The alternative operating scenario would assume that all the turbines were not installed or were by-passed for maintenance, malfunction or another event and the LFG would be flared. At the completion of the landfill construction, up to ten flares could be in operation. The use of odor control flares at various periods in the landfill construction and operation are included in the maximum emissions of ten operating flares. This scenario would have a maximum operating capacity of 33,100 scfm.

The Application presents the previous two operating scenarios as the two operating conditions that are the extreme for potential air pollutant emissions. Typically, the Facility would operate a combination of turbines and flares depending on the progress of the landfill construction, the budgetary considerations related to cost-benefit analysis, and constraints due to electricity demand. A LFGTE power plant would not only be a beneficial use of a waste gas, it would be necessary to provide revenue to support the high capital and operating cost of the desulphurization system.

C. Startup, Shutdown, Maintenance and Malfunctions

Startup and shutdown emissions for the control devices were not considered because the process is relatively short. During proper operation of the flare control devices the flame portion of the flare is at full operating capacity within two to five minutes of ignition. When there is a loss of flame in the open flares as indicated by a thermocouple; a loss of flame in the enclosed flare as indicated by the flame detector; or a change in temperature outside the set low or high temperatures, the LFG blower and the supply valve is automatically shut and the flare stops operating in less than one minutes. No excess emissions are generated. The turbines also shut down in less than five minutes. The turbine startup process from a cold start to full load is at most 45 minutes.

During maintenance or malfunction of a turbine, the LFG would be diverted to one or more flares. In the case of one or more of the desulphurization units require maintenance or malfunction or requiring maintenance, the untreated LFG would be diverted to the flares.

Based on the operating history of the Lo-Cat system at Central Landfill (a Waste Management Facility in Broward County, Florida), no more than 2 weeks (14 days) would be required for maintenance activities. During that period, LFG would be combusted in the landfill flares.

The startup, shutdown, and malfunction (SSM) plan is presented in **Appendix F** for the LFG flares. A SSM Plan for the turbines and desulphurization units would be implemented following the installation.

3.4 Construction Schedule

The construction of the landfill would continue until the available permitted air space associated with its construction is consumed. This is estimated to be around the year 2058. In compliance with the source obligation [F.A.C. 62-212.400(12)], there are no planned

stoppages of landfill construction and operation that would exceed 18 months. Control devices, permitted by this application, would be installed on an as needed basis. Under a compliance plan that would be developed for the application of a modified Title V operating permit, notification would be provided to the FDEP at least 60 days prior to installation of one of these control devices. A tentative schedule based on the predicted LFG generation has been developed for flares and turbines. **Appendix E** includes the LFG generation model and the control device schedule.

The control technology for SO₂ has been identified as a desulphurization unit and described in **Section 5.3**. The proposed unit is a LO-CAT® or Mini-CAT®, manufactured by Gas Technology Products, LLC; although an equivalent model that meets or exceeds the operating parameters of this unit may be substituted. A letter notification would be submitted to FDEP if a substitution is sought. The desulphurization unit(s) is expected require between 36 months for the permit process, procurement, design, manufacturing and installation process.

3.5 Proposed Source Emissions and Site Layout

Figure 3 is the Facility Site or Plot Plan. The Plan presents the areas where the turbines and flares would be located relative to the property lines, the access areas, landfill, and other features related to the landfill operation. Control devices would be installed in those areas as they are necessary.

Relative to the source emissions from the control devices, the construction project is a major modification, subject to PSD review. **Section 5.0** details the PSD review. The table below presents the maximum potential to emit for each pollutant for the project. The highest maximum for the PSD pollutants would be related to the following scenarios:

1. The maximum annual PTE for NO₂ and PM₁₀ would be the operation of seven turbines with two flares, one operating at a maximum 33-percent capacity.
2. The maximum annual PTE for CO, PM₁₀, would be the operation of ten flares.
3. The maximum annual PTE for SO₂, NMOC, VOC and H₂S are estimated to be essentially equivalent for both operating scenarios.

Table 2 Proposed Emissions with BACT

Pollutant	Maximum Potential Emissions (TPY)	Controls Applied	Operating Scenario 1, 2, or 3 (See list above)
Sulfur Dioxide	575	Yes	3
Nitrogen Dioxide	992	No	1
Carbon Monoxide	1173	No	2
NMOCs	23	Yes/No ¹	3
Volatile Organic Compounds	9	Yes/No ¹	3
Particulate Matter PM ₁₀	76.8	No	1
Hydrogen Sulfide	0.3	Yes	3

¹The flares and turbines are the control devices. Emissions shown for NMOC and VOC are conservatively estimated at 2 percent uncontrolled. Additional controls are not proposed for these emissions.

3.6 Stack Parameters and Sampling Facilities

The stack parameters used in air modeling and the stack sampling facilities are presented in **Appendix G**.

4.0 RULE APPLICABILITY ANALYSIS

4.1 General Rule Applicability

Title III: Existing facility is a major source of hazardous air pollutants (HAPs).
Title IV: Existing facility is not subject to the federal acid rain provisions.
Title V: Existing facility is a Title V major source of air pollution in accordance with Chapter 62-213, F.A.C.

The Application has been prepared to comply with the general areas of regulations:

- New Source Performance Standards (NSPS), 40 CFR 60, Subpart WWW, Municipal Solid Waste Landfills and Subpart KKKK Stationary Gas Turbines
- National Emissions Standards for Hazardous Air Pollutants (NESHAPS), 40 CFR 63, Subpart A, General Provisions and Subpart AAAA Municipal Waste Landfills
- [Florida Administrative Code Requirements (F.A.C.)]; including
 - Preconstruction Review
 - Prevention of Significant Deterioration (PSD)
 - Ambient Air Quality Standards (AAQS)

4.2 New Source Performance Standards (NSPS)

4.2.1 40 CFR 60, Subpart WWW, MSW Landfills

4.2.2 40 CFR 60, Subpart KKKK Stationary Combustion Turbines

Exceptions

- § 60.4335 Compliance if using water or steam injection
- § 60.4345 Continuous monitoring system (CEM) requirements
- § 60.4350 Data from CEM and excess emissions
- § 60.4365 Exemption from sulfur in fuel analysis
- § 60.4390 Operation of an emergency turbine
- § 60.4405 Performance tests with CEMs in place

4.3 National Emissions Standards for Hazardous Air Pollutants (NESHAPS)

4.3.1 40 CFR 63, General Provisions; Subpart A General Provisions

4.3.2 40 CFR 63, General Provisions; Subpart AAAA Municipal Waste Landfills

4.4 Florida Administrative Code (F.A.C.)

4.4.1 Chapter 62-4

Exceptions:

- 62-4.052 Regulatory Program and Surveillance Fees for Wastewater Facilities or Activities Discharging to Surface Waters.
- 62-4.240 Operation Permits for Water Pollution Sources.

- 62-4.242 Antidegradation Permitting Requirements; Outstanding Florida Waters; Outstanding National Resource Waters; Equitable Abatement.
- 62-4.243 Exemptions from Water Quality Criteria.
- 62-4.244 Mixing Zones: Surface Waters.
- 62-4.246 Sampling, Testing Methods, and Method Detection Limits for Water Pollution Sources.
- 62-4.249 Preservation of Rights.
- 62-4.250 Water Pollution Temporary Operation Permits; Conditions.
- 62-4.510 Scope of Part III General Permits
- 62-4.520 Definition
- 62-4.530 Procedures.
- 62-4.540 General Conditions for All General Permits.

4.4.2 Chapter 62-204 Air Pollution Control – General Provisions

Exceptions:

- 62-204.400 Public Notice and Hearing Requirements for State Implementation Plan Revisions

4.4.3 Chapter 62-210 Stationary Sources – General Requirements

Exceptions:

- 62-210.220 Small Business Assistance Program
- 62-210.340 Citrus Juice Processing Facilities

4.4.4 Chapter 62-212 Stationary Sources – Preconstruction Review

Exceptions:

- 62-212.500 Preconstruction Review for Nonattainment Areas
- 62-210.600 Sulfur Storage and Handling Facilities
- 62-210.710 Air Emissions Bubble
- 62-210.720 Actual Plantwide Applicability Limits (PALs)

5.0 PRECONSTRUCTION REVIEW [F.A.C. 62-212]

The Facility does not belong to one of the 28 stationary source categories that is a major stationary source if it emits more than 100 TPY of a PSD pollutant, the Facility must emit more than 250 TPY of any PSD pollutant to be considered major.

As defined in Rule 62-210.200, F.A.C., a "PSD Pollutant" is any pollutant listed as having a significant emission rate or significant net emission rate increase for a construction modification. Relevant air pollutants for the Facility are CO, NO_x, Carbon monoxide, Nitrogen oxides, Sulfur dioxide, particulate matter, ozone as volatile organic compounds, Hydrogen sulfide, and NMOCs. Therefore, it must be estimated if the facility emits more than 250 TPY of any of these pollutants.

5.1 Prevention of Significant Deterioration (PSD) Process [F.A.C. 62-212.400]

5.1.1 Applicability and Exemptions

The provisions of PSD apply to the construction or modification of air pollutant emitting facilities in those parts of the state in which the state ambient air quality standards (AAQS) are being met. As designated under F.A.C. 62-204.34, the Facility is located in an

attainment area for ozone, PM₁₀, SO₂, CO, and NO₂. The Facility is located in a Class II area and a designated PSD area for PM, SO₂, and NO₂. Located approximately 169 kilometers from the Facility's southern most property line, the Everglades National Park is the closest Class I area. The Biscayne Bay National Park is a Class II area, however, relative to air quality source impacts, the Federal Land Managers (FLMs) consider the Park an area of environmental concern and sensitivity.

Because this project is a major modification, PSD applicability for an existing emission unit is determined by the Baseline Actual to Projected Actual Emissions Test. However, in the unique case of landfill operations, the projected emissions would be estimated on the Baseline Actual to Projected Potential to Emit. Since LFG generation from the waste deposition may increase until the landfill is closed, it is the Facility's intention to use the existing and proposed control devices to their full potential.

The PSD applicability was tested for the applicable PSD pollutants. As defined in Rule 62-210.200, F.A.C., a "PSD Pollutant" is any pollutant listed as having a significant emission rate. For the Facility, as a major stationary source for a PSD pollutant, a significant emission rate means a net increase of the pollutant emissions that would equal or exceed:

- Carbon monoxide: 100 tons per year (TPY)
- Nitrogen oxides: 40 TPY
- Sulfur dioxide: 40 TPY
- Particulate matter less than 10 microns in diameter: 25 TPY
- Ozone: 40 TPY of volatile organic compounds
- Hydrogen sulfide (H₂S): 10 TPY
- 50 TPY of NMOCs

No exemptions apply.

5.1.2 Source Emissions and PSD Emission Rate Triggers

The increases from the actual emission rate to the potential emission rate for the project before BACT is considered is compared in the table below. A more detailed summary table for each control device is presented in **Appendix B**, Support Calculations.

Table 3 – Significant Emissions Increase Levels for Actual Emissions

Pollutant	Baseline Actual Emissions	Significant Emission Increase	Actual to Potential Net Increase for Proposed Project	Exceeds PSD trigger level? (Note 1)
Sulfur Dioxide (TPY)	1,209	40	7,124	Yes
Nitrogen Dioxide (TPY)	34	40	958	Yes
Carbon Monoxide (TPY)	120	100	1321	Yes
NMOCs (TPY)	3.4	50	20	No
Volatile Organic Compounds (TPY)	1.4	40	7.6	No
Particulate Matter PM ₁₀ (TPY)	9	15	68	Yes
Hydrogen Sulfide (TPY)	0.7	10	3.8	No

Note 1: A significant net increase occurs for the PSD pollutants, SO₂, NO₂, CO, and PM₁₀ based on the Baseline Actual-to-Projected Potential PSD Applicability Test for the proposed modification for the landfill.

5.2 Control Technology Review [F.A.C. 62-212.400(4)(c) and (10)]

Under Florida's Preconstruction Review Process (PCR), a PSD permit process requires a Control Technology Review or a BACT analysis in order to identify the pollution control device or system that is most suitable with respect to technological and economic considerations [F.A.C. 62-212.400(4)(c) and (10)]. A BACT analysis was performed for the following pollutants that the modification would cause the source to emit in significant amounts; SO₂, NO₂, CO, and PM₁₀. The code defines and provides the general approach to support a BACT analysis under Definitions [F.A.C. 62-210.200(39)].

- (a) *An emission limitation, including a visible emissions standard, based on the maximum degree of reduction of each pollutant emitted which the Department, on a case by case basis, taking into account:*
 1. *Energy, environmental and economic impacts, and other costs;*
 2. *All scientific, engineering, and technical material and other information available to the Department; and*
 3. *The emission limiting standards or BACT determinations of Florida and any other state; determines (what) is achievable through application of production processes and available methods, systems and techniques (including fuel cleaning or treatment or innovative fuel combustion techniques) for control of each such pollutant.*
- (b) *If the Department determines that technological or economic limitations on the application of measurement methodology to a particular part of an emissions unit or facility would make the imposition of an emission standard infeasible, a design, equipment, work practice, operational standard or combination thereof, may be prescribed instead to satisfy the requirement for the application of BACT. Such standard shall, to the degree possible, set forth the emissions reductions achievable by implementation of such design, equipment, work practice or operation.*
- (c) *Each BACT determination shall include applicable test methods or shall provide for determining compliance with the standard(s) by means which achieve equivalent results.*
- (d) *In no event shall application of best available control technology result in emissions of any pollutant which would exceed the emissions allowed by any applicable standard under 40 CFR Parts 60, 61, and 63.*

The definition above describes how BACT is generally developed. The proposed construction modification to the air construction permit for this MSW landfill is substantially different from other industries. In most PSD projects the facility has not been built or it has been built and is operational. In the case of an MSW landfill project, the facility has been permitted and construction is concurrent to the operation. A review of existing air permits for MSW landfills in Florida and other states found an inconsistent definition of the EU source. Often permit writers have looked at the flares or other combustion control devices for landfills as emission sources along with the landfill and each control device is permitted as it is needed. Other times, the landfill would be designated the EU with the flares included as control devices. This Application considers the landfill, not the associated control devices, as the only emission unit. The emission unit emits the air pollutants NMOC and HAPs.

It is expected that up to a three year period would be necessary for permit application approval, procurement, design and construction for the proposed BACT installation. Additionally, during the same period, the same process would be occurring for the LFGTE power plant. In the interim period, the facility would have to utilize flaring to achieve compliance with NSPS WWW.

Appendix D presents the BACT analysis summary report.

5.3 Details of Proposed Control Technologies

The proposed control technology for the potential emissions for the proposed modification construction and the facility are described in this section.

5.3.1 Control of NMOC and HAPs

NSPS for MSW landfills with the potential to emit (before controls) greater than 50 TPY of NMOCs install LFG collection and control devices. Combustion is a typical and acceptable means to destroy NMOCs and HAPs. Currently, OLI uses LFG flares, both open and enclosed, to control these air pollutants. Specification sheets for the proposed additional utility LFG flares are presented in **Appendix G**.

Another combustion device to control air pollutants are turbines designed to use LFG as fuel. The turbines will produce energy that would be used on site and sold into the energy grid. For this project, the Mars 100 Solar Turbine would be installed. Specifications for the proposed turbines are presented in **Appendix G**.

For both control devices, the stack parameters used for modeling are presented in **Appendix G**.

5.3.2 Control of SO₂

As described in **Section 5.2**, a BACT analysis was performed. The best control technology was determined to be a front-end system that removes H₂S before the LFG is combusted. Of the many available technologies, LO-CAT® is best suited for the high sulfur and gas flow rate estimated for the project. This desulphurization system would be located upstream of the combustion devices; both the turbines and the flares, including the odor control flares.

Pollutant	Baseline Actual Emissions	Actual to Potential Net Increase for Proposed Project
Sulfur Dioxide (TPY)	1,209	(634)
Hydrogen Sulfide (TPY)	0.7	(0.4)

LO-CAT® is an aerobic process to control hydrogen sulfide odors developed by Gas Technology Products, LLC, subsidiary of Merichem Company. The process uses a chelated iron catalyst to convert H₂S into elemental sulfur.

The LO-CAT® system consists of a venturi absorber and a mobile bed oxidizer. Landfill gas is treated in the absorber vessel by the iron catalyst, which is held in solution by organic chelating agents that form a film around the iron ions. The chelating agents prevent precipitation of either iron sulfide or iron hydroxide. In the absorber, H₂S is absorbed into a slightly alkaline aqueous solution. The H₂S ionizes to bisulfide, which is oxidized to sulfur by reducing the iron ion from ferric to ferrous state. The reduced ions are then transferred to the oxidizer, where the catalyst is regenerated. Atmospheric oxygen is absorbed into the LO-CAT® (Mini-Cat) solution to re-oxidize ferrous iron to ferric iron, hence regenerating the catalyst.

The overall reaction is an isothermal modified Claus reaction. The chemical additions required to maintain the above reactions are caustic for maintaining the pH, chelated iron, which is lost in the sulfur removal process, and chelating agents that are degraded in the process and need to be replaced. Thiosulfate and bicarbonates may form as side reactions to produce excess amounts of sour gas and carbon dioxide. Caustic is required to be added under such conditions to maintain the pH.

A product brochure that includes a link to the company website is presented in **Appendix H**.

5.4 Summary of the Ambient Air Quality Impact Analysis

5.4.1 Source Impact Analysis [F.A.C. 62-212.400(5)]

The source impacts did not exceed NAAQS or Florida AAQS at any location for any PSD pollutant. An air quality analysis is presented in the report "Ambient Air Quality Impact Analysis for Okeechobee Landfill" (AQIA) prepared for the Application and provided in **Section III** of the Air Permit Application.

5.4.2 Air Quality Analysis [F.A.C. 62-212.400(7)]

The owner must provide any monitoring data or analysis as required. Monitoring data is used to develop background concentrations for determination of compliance with AAQS. Ambient air quality data for Florida are available from a monitoring network operated by the FDEP's Division of Air Resource Management. The monitoring station in Riviera Beach, Palm Beach County was used for SO₂ background data as it is the most representative of the Okeechobee Landfill due to its relative proximity to the station compared to all other stations. The monitoring station in Fort Pierce, St. Lucie County was used for NO₂ background data. These were the closest monitoring sites to Okeechobee.

Additional details are provided in **Section 4.2** of the AQIA in **Section III** of the Application.

5.4.3 Air Quality Impact Since 1977 [F.A.C. 62-212.400(4)(e)]

The significant impact area affected by the project did not have significant commercial, residential, industrial growth since 1977 and hence the air quality impact was negligible. See **Section 5.0** of the AQIA in **Section III** of the Application.

5.4.4 Additional Impact Analyses [F.A.C. 62-212.400(8)]

The additional impact analysis was addressed in **Section 5.0** of the AQIA in **Section III** of the Application. In summary:

- The significant impact area is primarily rural farmland with no other residential, commercial, industrial or other growth. There is no air quality impact from growth in this area of impact.
- No impact is expected on the soil, vegetation and wildlife in the significant impact area from the proposed modification.
- No adverse visibility impairment in the impact area is predicted for the proposed modification.

6.0 PRECAUTIONS TO PREVENT EMISSION OF UNCONFINED PARTICULATE MATTER

The Facility routinely takes steps to prevent the emission of uncontrolled particulate matter to the atmosphere. The steps are outlined below. It should be noted that the steps and procedures listed might be augmented from time to time. The weather patterns of the Okeechobee area also contribute to dust control due to the large amounts of rainfall during the year.

- Waste is placed in lifts in the landfill in a manner to prevent windblown litter and dust. The working face is kept as small as practicable to further reduce windblown dust and litter.
- Portable fences are used around and near the working face to keep windblown litter in the work area.
- Waste is covered daily to prevent windblown litter after operation hours.
- Paved Roads: During hours of operation, the frequency of vehicle traffic may warrant dust control measures. Roadway sweeping will be performed as needed, especially in the portions of the year with less rainfall. Roadway washing will take place as needed to prevent carry out of dirt and mud onto adjoining roadways.
- Unpaved Roads: Roadways in the active areas of the landfill will be graded and compacted to allow safe passage of vehicles and to prevent carry out of dirt and mud. Dust control will be managed using a water truck.
- Roads General: The type and frequency of the dust control operations will vary according to weather conditions. Maintenance of the paved and unpaved roads will be performed from time to time as needed.

**Prevention of Significant Deterioration (PSD)
Air Construction (AC)
Permit Application**

**No. 1270-2
Facility No. 0930104
Okeechobee Landfill
(Formerly Berman Road Landfill)
Okeechobee, Florida**

**Prepared for:
Okeechobee Landfill, Inc.**
10800 N.E. 128th Avenue
Okeechobee, FL 34972
(863) 357-0111

Prepared by:



Shaw Environmental and Infrastructure, Inc.
88C Elm Street
Hopkinton, MA 01748

Submitted to:

Florida Department of Environmental Protection
Air Resource Management
2600 Blair Stone Road MS 5500
Tallahassee, Florida 32399-2400

February 27, 2007

TABLE OF CONTENTS
PSD/AC Permit Application No. 1270-2
Okeechobee Landfill, Facility No. 0930104

- SECTION I. Application for Air Permit (Long Form)**
- SECTION II. Prevention of Significant Deterioration (PSD) Air Construction (AC)
Permit Application Support Documentation**
- SECTION III. Air Quality Impact Analysis**

Section I.

Application for Air Permit (Long Form)

**Section I
Application for Air Permit
(Long Form)**

**No. 1270-2
Facility No. 0930104
Okeechobee Landfill
(Formerly Berman Road Landfill)
Okeechobee, Florida**

**Prepared for:
Okeechobee Landfill, Inc.**
10800 N.E. 128th Avenue
Okeechobee, FL 34972
(863) 357-0111

Prepared by:



Shaw Environmental and Infrastructure, Inc.
88C Elm Street
Hopkinton, MA 01748

Submitted to:

Florida Department of Environmental Protection
Air Resource Management
2600 Blair Stone Road MS 5500
Tallahassee, Florida 32399-2400

February 27, 2007

Section II.

Prevention of Significant Deterioration (PSD) Air Construction (AC) Permit Application Support Documentation

Section III.

Air Quality Impact Analysis

Precautions to Prevent Emissions of Unconfined
Particulate Matter

**Please refer to Section 6.0 of Section II – PSD/AC Permit
Application Support Documentation**

OFFICE: Pittsburgh, PA
 DATE: 2/7/97
 DESIGNED BY: ---
 DRAWN BY: B. Snyder
 CHECKED BY: R. Fagan
 APPROVED BY: ---
 DRAWING NUMBER: 121525-B1

File: D:\Shaw Offices - CUD Files\Projects\121525-B1.dwg
 Size: 917 bytes, Feb 20, 2007 - 10:08am
 Plotter: HP, allison.vander...

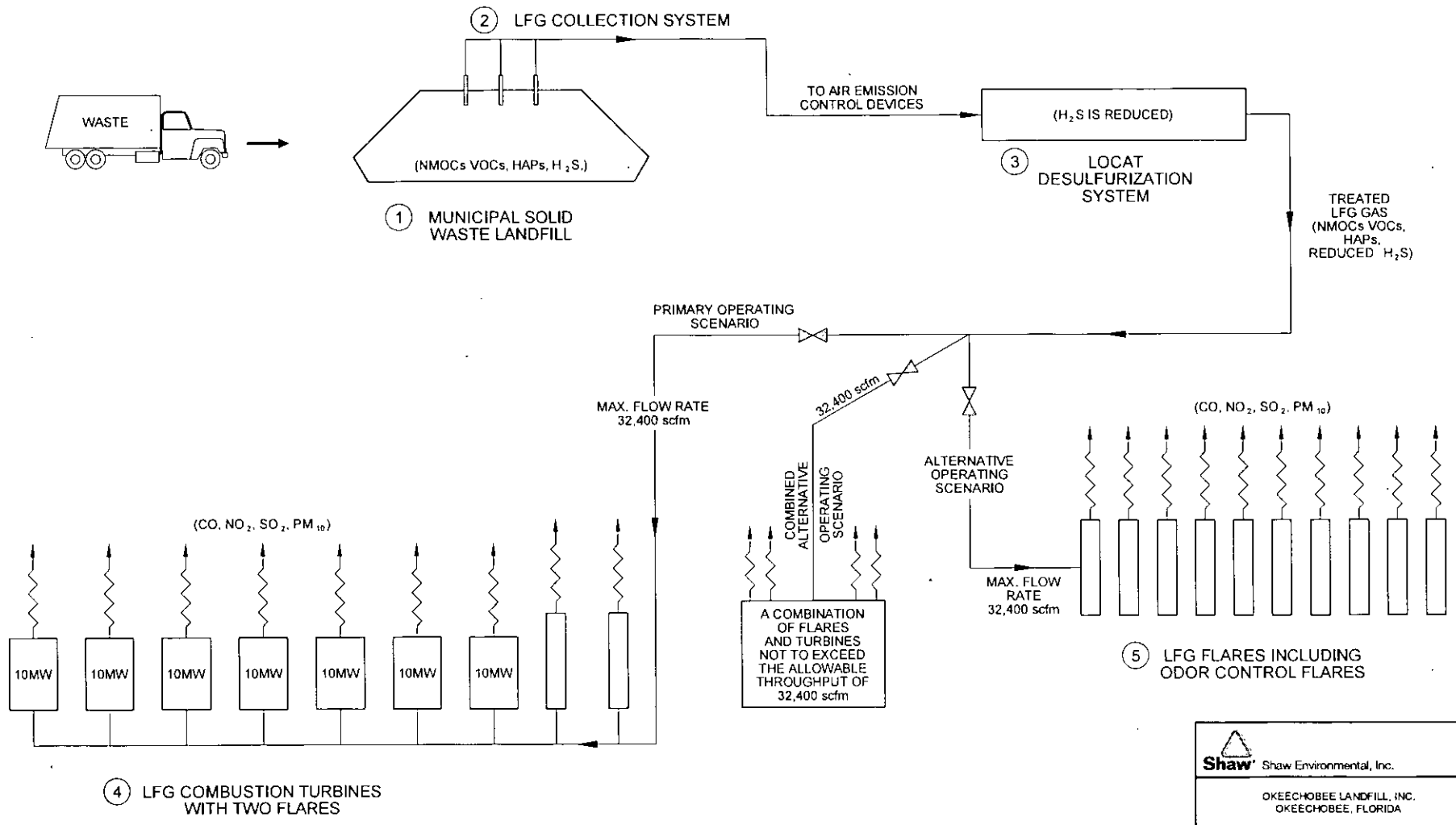

NOTE:
 FOR CLARITY, THIS PROCESS FLOW DIAGRAM
 DEPICTS THE ADDITIONAL CONTROL DEVICE
 FOR THE TURBINES OPERATING SCENARIO

Shaw Shaw Environmental, Inc.
 OKEECHOBEE LANDFILL, INC.
 OKEECHOBEE, FLORIDA

FIGURE 2
 FACILITY ID 0930104
 PROCESS FLOW DIAGRAM
 AIR CONSTRUCTION
 PERMIT APPLICATION 1270-2

Rule Applicability Analysis

**Please refer to Section 4.0 of Section II – PSD/AC Permit
Application Support Documentation**

**SECTION III
AIR CONSTRUCTION
PERMIT APPLICATION 1270-2**

**AIR QUALITY IMPACT ANALYSIS FOR
OKEECHOBEE LANDFILL, FACILITY ID No. 0930104**

Prepared for:

**Okeechobee Landfill, Inc.
Okeechobee, Florida**

Prepared by:

Shaw Shaw Environmental, Inc.

Shaw Environmental, Inc.
Monroeville, Pennsylvania

Project No. 121525
February 2007

Table of Contents

List of Tables.....	iii
List of Figures.....	iii
List of Appendices.....	iii
List of Acronyms and Abbreviations.....	iv
1.0 Introduction.....	1
2.0 Background Information.....	2
2.1 Description of Site.....	3
2.2 Description of Emission Sources.....	3
2.3 Elements of Air Quality Analysis.....	4
3.0 Technical Approach and Methodology.....	8
3.1 Air Dispersion Model.....	8
3.2 Source Parameters.....	9
3.3 Load Analysis.....	11
3.4 Building Downwash Analysis.....	12
3.5 Meteorological Data.....	13
3.6 Receptor Layout.....	13
3.7 NO _x to NO ₂ Conversion.....	15
3.8 Terrain Data.....	15
4.0 Air Quality Analysis.....	16
4.1 Preliminary Analysis.....	16
4.2 Pre-Application Monitoring Requirement Analysis.....	18
4.3 Full Impact Analysis.....	19
4.3.1 Full Impact Analysis Receptors.....	20
4.3.2 PSD Class II Increment Compliance Demonstration.....	20
4.3.3 AAQS Compliance Demonstration.....	22
5.0 Additional Impact Analysis.....	23
5.1 Class I Area Air Quality Analysis.....	23
5.2 Growth Analysis.....	24
5.3 Analysis of Impact on Soil Vegetation and Wildlife.....	25
5.4 Visibility Impairment Analysis.....	25
6.0 Conclusions.....	26

List of Tables

Table 2-1	PSD Significance Summary
Table 2-2	Reference Concentrations of Regulated Pollutants for PSD Analysis
Table 2-3	Reference Concentrations of Regulated Pollutants for Class I Impact Analysis
Table 3-1	Modeled Emissions Rate
Table 3-2	Modeled Stack Parameters
Table 3-3	Load Analysis for Combustion Turbine
Table 3-4	Buildings/Structures Considered for Aerodynamic Downwash
Table 4-1	Significance Analysis Results
Table 4-2	PSD Monitoring Requirement Analysis Results
Table 4-3	Background Concentrations Used for AAQS Analysis
Table 4-4	Design Concentrations Used in Full Impact Analyses
Table 4-5	Emission Sources Modeled for PSD Class II Increment Compliance
Table 4-6	PSD Increment Consumption Analysis Results
Table 4-7	AAQS Analysis Results

List of Figures

Figure 2-1	Location of Okeechobee Landfill
Figure 2-2	Plot Plan of Okeechobee Landfill
Figure 3-1	Locations of Meteorological Station and background Monitoring Stations
Figure 3-2A-F	Windroses for West Palm Beach Meteorological Monitoring Station for 2001-2005
Figure 3-3A-D	Layout of Preliminary Analysis Receptors
Figure 3-4A-D	Layout of Full Impact Analysis Receptors Routine BACT Scenario
Figure 3-5A-D	Layout of Full Impact Analysis Receptors Back-up BACT Scenario

List of Appendices

Appendix A	Calculations and OEPA Engineering Guide #69
Appendix B	Back-up Data and Information
Appendix C	Off-Site PSD and AAQS Emission Source Data
Appendix D	Input/Output Files (CD)

List of Acronyms and Abbreviations

AAQS	Ambient air quality standard
AQRV	Air quality related values
BACT	Best Available Control Technology
BPIP	building profile Input program
CD	Control device
CO	Carbon monoxide
DEM	Digital elevation maps
F.A.C	Florida Administrative Code
FDEP	Florida Department of Environmental Protection
FLM	Federal land manager
GEP	Good engineering practice
H ₂ SO ₄	Sulfuric acid
HAP	Hazardous air pollutant
K	Kelvin
Kw	kilowatt
LFG	Landfill gas
LFGTE	Landfill gas to energy
m/s	meters per second
NAAQS	National ambient air quality standard
NAD	North American datum
NMOC	Non methane organic compounds
NO ₂	Nitrogen dioxide
NO _x	Nitrogen oxides
NPS	National park service
NSR	New Source Review
NWS	National weather service
OEPA	Ohio Environmental protection Agency
OLI	Okkechobee Landfill Incorporated
PBL	Planetary
PM ₁₀	Particulate matter with aerodynamic diameter less than or equal to 10 microns
PSD	Prevention of significant deterioration
PTE	Potential to emit
Scfm	standard cubic feet per minute
SIP	State implementation plan
SO ₂	Sulfur dioxide
TCEQ	Texas Commission on Environmental Quality
USEPA	United States Environmental Protection Agency
USGS	United States Geological Service
UTM	Universal transverse mercaptor
VOC	Volatile organic compounds

1.0 Introduction

As mentioned in Section 1.0 of Prevention of Significant Deterioration (PSD) Air Construction Permit Application Report (Permit Application Report) the net emissions from the proposed changes in the facility exceeded the significant emission rates for New Source Review (NSR) for the following pollutants: SO₂, NO_x, PM₁₀, and CO. Therefore a Best Available Control Technology (BACT) analysis was conducted, which is described in Section 2.0 of the Permit Application Report. Per the NSR (40 CFR 52), the applicant is also required to conduct an air quality analysis associated with construction and operation of the new source or the modification. The main purpose of the air quality analysis is to demonstrate that new emissions from the proposed new source or modification after installation of the BACT will not cause, or contribute to violation of any applicable National or Florida Ambient Air Quality Standards (AAQS) or Prevention of Significant Deterioration (PSD) increment. The air quality analysis is required for each regulated pollutant for which the emission from the new source or modifications are "significant" as defined by the United States Environmental Protection Agency (USEPA) in 40 CFR Part 52. In addition, additional impact analysis is required to identify impacts of growth on surrounding area as a result of the proposed new source or modification.

USEPA has delegated the NSR program to Florida Department of Environmental Protection (FDEP), which has jurisdiction over this program in the state. FDEP's NSR program is codified in Chapter 62-212 (Stationary Sources – Preconstruction Review) and closely follows the USEPA NSR program. The requirements for air quality analysis are similar to the federal program.

This Section III of the Air Construction Permit Application provides details of the air quality analysis conducted for the proposed changes in the Okeechobee Landfill facility (Facility). The Appendix is arranged as follows:

- Section 2.0: Background Information
- Section 3.0: Technical Approach and Methodology
- Section 4.0: Air Quality Impact Analysis
- Section 5.0: Additional Impact Analysis
- Section 6.0: Conclusions

Please note that one element of an air quality analysis is Class I area impact analysis. The analysis requires estimation of impact of the proposed project on nearby federally designated Class I areas in terms of air quality, acidic deposition, and visibility degradation, which are part of the air quality related values (AQRVs).

2.0 Background Information

The Okeechobee Landfill Facility (Facility), which is owned and operated by Okeechobee Landfill, Inc. (OLI), is comprised of an existing municipal solid waste (MSW) landfill and supporting operations. The facility has been operational since 1981 and under the existing solid waste permit will continue to construct and operate the landfill until approximately 2058. The landfill is an emission unit for nonmethane organic compounds (NMOCs) and hazardous air pollutants (HAPs), which are landfill gas (LFG) constituents. The typical control device for NMOCs and HAPs in LFG is flaring of the gas. Combustion can also be achieved by engines and turbines. The proposed project includes the construction of a landfill-gas-to-energy (LFGTE) plant as the primary control devices. The LFGTE plant will consist of LFG turbines with flares as a back up option.

The Facility currently has two enclosed landfill gas flares with Evap® systems and an open, utility flare as a backup. The two enclosed flares and the backup flare are operated under the current Title V operation permit. There is currently an odor control flares that is operating under a first amended order between FDEP and Okeechobee Landfill Inc. (OLI). A second amended order allows up to five flares to be operated at the Facility. The estimated maximum potential-to-emit (PTE) based on LFG generation estimates occurs shortly after closure and will increase from current 6,000 standard cubic feet per minute (scfm) to 32,400 scfm. There is a current need to install more flaring capacity for control of collected LFG, however, as the landfill construction is ongoing, turbines will be installed and landfill gas will be diverted from the flares to the gas turbines, which will beneficially use the landfill gas by converting it into electricity. Under this scenario, the landfill gas will be always combusted in turbines (numbers increasing with time) and one flare to combust residual gas after full capacity is achieved in turbines. As the gas generation reaches the maximum for the flare, the gas will be transferred to a new turbine, and the flare will be ready for excess gas generated from the landfill.

Although the Facility is not a permitted as a major stationary source; recent fuel analysis for hydrogen sulfide indicates that the actual emissions do qualify the Facility as a major stationary source. Additionally, the expected emission increases from the current level to the predicted levels at the completion of the landfill construction are above the significant emission rate therefore, triggering PSD review under Chapter 62-212.400. The Application provides the information required by Chapter 62-212.400, F.A.C., for Prevention of Significant Deterioration (PSD) review.

The summary of significant emission rate evaluation for all PSD pollutants as described in Section 5.2 of the Permit Application Report is shown in Table 2-1. The pollutants exceeding the significant emission rates from the proposed changes are: i) SO₂; ii) NO_x; iii) PM₁₀; and iv) CO. A BACT analysis has been performed and would require installation of a LFG desulfurization system installed before the destructive control devices (e.g. flares) to control SO₂.

Table 2-1: PSD Significance Summary

Pollutant	PSD Emission Significant?
Nitrogen Oxides (NO _x)	Yes
Carbon Monoxide (CO)	Yes
Sulfur Dioxide (SO ₂)	Yes
Particulate Matter, diameter <10 microns (PM ₁₀)	Yes
Hydrogen Sulfide (H ₂ S)	No
Ozone as Volatile Organic Compounds (VOC)	No

Note: Other PSD regulated compounds are not emitted in any appreciable quantity during LFG combustion

2.1 Description of Site

The Facility is located in Okeechobee County in Central Florida near Lake Okeechobee at approximately 27°20'24" latitude and 80°41'27" longitude. Figure 2-1 shows the site within the state of Florida and nearby natural features. The 4300 acre site contains the existing Berman Road Landfill, the proposed Clay Farms expansion, and auxiliary services.

The terrain surrounding the Facility is mostly flat with terrain heights reaching 60 feet within 5 kilometers (km) from the property boundary line. The vegetation is mostly grassland and mangroves. Land use in the surrounding area is mostly rural. A large water body (Lake Okeechobee) is located approximately 30 km southwest of the Facility.

The area is not industrial and there are no large industrial sources within 10 km from the Facility. Okeechobee County is in attainment for all regulated pollutants with federal NAAQS and FDEP AAQS. The nearest Class I area is Everglades National Park approximately 169 km south of the southernmost property boundary of the Facility.

There is no meteorological monitoring station in the Facility. Meteorological data from nearest National Weather Service (NWS) station in West Palm Beach (approximately 60 km southeast of Facility) shows a predominantly westerly wind pattern. Climatological data shows that average and maximum wind speed in the area are approximately 4 meters per second (m/s) and 10 m/s. Average annual rainfall in the area is 1560 millimeter (mm).

Figure 2-2 shows a plot plan for the existing Facility. The location of the existing flares and the locations of the proposed turbines and proposed flares are also shown in Figure 2-2.

2.2 Description of Emission Sources

The current and future operations have been described in detail in Section 2.0 and 3.0 of the Air Permit Application. For the purpose of air quality analysis, the following LFG combustion emission sources have been considered:

Existing Operation (Interim Operating Scenario):

- Two existing enclosed flares (CD001 and CD002) used as a control devices each rated at 3,000 scfm of LFG; and

- Two existing and one new open flares (CD003 to CD005) one used for odor control and LFG control devices each rated at 3,300 scfm LFG.

Future Operation:

Future operations require installation of gas turbines and flares in stages based on the increase in rates of generation of landfill gases. At the completion of the project, the following emission sources are considered for the air quality analysis:

- i) Routine Operating Scenario (BACT Scenario):
 - Seven LFG turbines (CD011 to CD017) used as control devices each rated at 4,000 scfm of LFG;
 - One open flare (CD003) used as a control device rated at 3,300 scfm of LFG; and
 - One open flare (CD004) used as a control device rated at 3,300 scfm LFG, but only operating at one third capacity (1,100 scfm).
- ii) Back-up (BACT) Operating Scenario (in case gas turbines are unavailable)
 - Eight open flares (CD003 through CD010) used as control devices each rated at 3,300 scfm of LFG
 - Two existing enclosed flares (CD001 and CD002) used as control devices each rated at 3,000 scfm of LFG

Both scenarios under the future conditions will have BACT installed for SO₂ as described earlier.

The emission rates used for the air quality analysis from these emission sources are described in Section 3.2 of this Appendix.

Federal and FDEP PSD regulations require the BACT scenarios only to be considered for air quality impact analysis. In this case, both BACT scenarios, namely the routine operating scenario and the back-up operating scenario were considered. Additionally, per FDEP request, air quality impact analysis for the interim operating scenario is also included *for informational purposes only*.

2.3 Elements of Air Quality Analysis

Florida's State Implementation Plan (SIP), which contains the PSD regulations, has been approved by USEPA and therefore PSD approval authority has been granted to FDEP. FDEP's PSD regulations are codified in Rule 62.212.400, Florida Administrative Code (F.A.C.) and are same as the federal PSD regulations codified in 40 CFR Part 51.166. FDEP uses the term ambient air quality standard (AAQS), which has same meaning as federal NAAQS. Florida AAQS are equal or more stringent (24-hour average and annual SO₂) than NAAQS. Hereinafter the term AAQS will be used to represent FDEP terminology and compliance with AAQS will also mean compliance with NAAQS.

The air quality analysis involves two phases as follows:

Preliminary Analysis: The preliminary analysis includes only the significant net emission increase from proposed modifications. The result of the preliminary analysis is used to determine whether a more comprehensive "full impact analysis" is necessary. The full impact analysis is not required if the preliminary analysis shows that ambient impact of regulated pollutant is below "significance level".

Preliminary analysis is also used to determine the modeling domain (significant impact area) in case full impact analysis is required. Additionally, the analysis determines if pre-application monitoring is necessary based on whether the ambient impacts exceed PSD significant monitoring concentration.

Full Impact Analysis: This analysis is required for any regulated pollutant for which the ambient impact from the proposed modification exceeds the prescribed "significance level" concentration. The analysis expands the preliminary analysis in that it considers emissions from:

- The proposed source or modification;
- Existing sources (on-site and off-site)
- Secondary emissions resulting from the proposed new source or modification, if any.

For SO₂, NO₂, and PM₁₀, the full impact analysis consists of separate analyses for AAQS and PSD increments. For AAQS compliance, the background concentration resulting from upwind and smaller (area) sources are also included either from a pre-application monitoring station data or from existing USEPA approved monitoring station data. The existing (both on-site and off-site sources) used for PSD increment and AAQS compliance demonstration are selected using different criteria as prescribed in 40 CFR Part 51 and 62.212.400 F.A.C.

Table 2-2 lists the USEPA and FDEP significance concentration level, significant monitoring concentration, AAQS and Class II PSD increments for SO₂, NO₂, PM₁₀, and CO for reference.

Table 2-2: Reference Concentrations of Regulated Pollutants for PSD Analysis

Pollutant	Averaging Period	Significance Level Concentration (ug/m3)	Significant Monitoring Concentration (ug/m3)	FDEP AAQS (µg/m ³)	Class II PSD Increment (ug/m3)
NO ₂	Annual	1	14	100	25
CO	1-Hour	2,000	N/A	40,000	N/A
	8-Hour	500	575	10,000	N/A
SO ₂	3-Hour	25	N/A	1300	512
	24-Hour	5	13	260	91
	Annual	1	N/A	60	20
PM ₁₀	24-Hour	5	10	150	37
	Annual	1	N/A	50	19

Notes:

1. Federal NAAQS values for the concentration are same as FDEP AAQS values except for 24-Hour and Annual SO₂, which are less than FDEP AAQS
2. Other PSD pollutants are not discussed since these are not relevant for this project

Additional Impact Analysis: All PSD permit applications are required to prepare additional impact analyses for each pollutant which are emitted by the proposed new source or modification. The elements of the additional impact analyses are:

- A projection of industrial, commercial, and residential growth that may occur in the area due to the proposed changes and associated impact on air quality;
- A projection of impact on soil and vegetation due to the proposed source; and
- Visibility impairment analysis associated with the project's emissions.

The depth of the analyses is dependent on the quantity of emissions, sensitivity of local soils, vegetation, and visibility in the source's impact area.

Class I Area Impact Analysis: Class I areas are areas of special national or regional value from a natural, scenic, recreational, or historic perspective. Adverse impacts on Class I areas are prevented by:

- i) Ensuring that Class I area increments are not exceeded; and
- ii) Ensuring that the air quality related values (AQRVs) in the Class I areas are not significantly affected.

Typically, Class I area within 100 km of the proposed source or modification is considered in the analysis. Currently, due to current emphasis in improving visibility in Class I areas via the Regional Haze Rule, Class I areas at greater distances are also being included in the analysis.

The Federal Class I area nearest to the source is the Everglades National Park in South Florida, Located approximately 169 kilometers from the facility's southern most property line. The Biscayne Bay National Park is a Class II area; however, it is considered important relative to air pollution impacts and is also considered in the analyses.

The Class I area air quality analysis is conducted in two phases as follows:

- i) Significant Impact Analysis: the net emissions increase from project is used in determining the air quality impact in the Class I area and is then compared to the Class I area significance levels concentration. The Draft New Source Review Workshop Manual (1990) lists Class I significance level concentration as 1 ug/m³ for 24-hour average for all pollutants with a NAAQS. USEPA has subsequently proposed lower significance level concentration as shown in Table 2-3. These levels in Table 2-3 have not been officially promulgated as part of the PSD review process. However, FDEP has accepted the use of these significance level concentration for Class I areas.

If the project's air quality impact does not exceed the Class I significance level concentration, then no further air quality analysis is required.

- ii) Class I area PSD Increment Analysis: This analysis is needed if the project's air quality impact exceeds the Class I area significance level concentration. Table 2-3 shows the Class I area PSD increments, which can not be exceeded by the project's air quality impact.

Table 2-3: Reference Concentrations of Regulated Pollutants for Class I Impact Analysis

Pollutant	Averaging Period	Proposed USEPA Class I Significance Level (ug/m ³)	Current USEPA Class I PSD Increments (ug/m ³)
NO ₂	Annual	0.1	2.5
SO ₂	3-Hour	1	25
	24-Hour	0.2	5
	Annual	0.1	2
PM ₁₀	24-Hour	0.3	10
	Annual	0.2	5

Notes:

1. Current Class I area significance level is 1 ug/m³ for 24 hour average concentration for all PSD pollutants. Proposed Class I significance levels are guidelines at this time and have not been adopted yet in PSD regulations.

- iii) AQRV Analysis

The AQRV analysis is required for submission to Federal land Managers (FLM) who are charged with affirmative responsibility to protect the AQRVs. The AQRVs vary with the Class I area being considered. Based on discussions with the National Park Service (NPS), the AQRVs to be considered for the Everglades National Park are: i) deposition of total nitrates and sulfates; ii) visibility degradation; and iii) impact of ozone on vegetations. The results of these analyses are submitted to NPS for AQRV analyses.

3.0 Technical Approach and Methodology

Air dispersion was performed to determine ambient concentrations of applicable criteria pollutants in the near field from the various proposed emission points within the facility. The results of the air dispersion modeling were used to demonstrate compliance with PSD and AAQS.

The air dispersion was performed generally in conformance with the following guideline documents, with appropriate modifications based on site-specific data:

- "New Source Review Workshop Manual" Draft October 1990
- "Guidelines on Air Quality Models"; Appendix W of 40 CFR Part 51
- Building Profile Input Program (BPIP), USEPA, 1995
- SCREEN3 User's Guide September 1995
- AERMOD User's Guide September 2004, Addendum December 2006
- AERMAP User's Guide October 2004, Addendum December 2006
- AERMET User's Guide November 2004, Addendum December 2006
- Supplemental Implementation Guidelines for AERMOD dated September 25, 2005

The elements of the air quality impact analysis have been described in Section 2.3. The rest of this section describes the methodology of the air dispersion modeling and input data for the air dispersion model.

3.1 Air Dispersion Model

The latest version of USEPA's AERMOD (version 07026) air dispersion model was used for the air quality impact analysis. AERMOD is currently USEPA's regulatory approved air dispersion model for industrial sources as per Guidelines on Air Quality Models (Guideline), published in Appendix W to 40 CFR Part 51 (as revised).

AERMOD is a steady-state plume model that incorporates air dispersion based on planetary boundary layer turbulence structure and scaling concepts, including treatment of both surface and elevated sources, and both simple and complex terrain. AERMOD tracks plume mass that penetrates into the elevated stable layer and then allows it to reenter the boundary layer when and where appropriate. For complex terrain, the plume is modeled as either impacting and/or following the terrain. The model calculates short-term and long-term concentration at selected receptor locations based on source emissions, meteorology and land use in the modeling domain. USEPA has recommended AERMOD to be used for modeling domain up to 50 km from a source.

The AERMOD modeling system including the companion pre-processors. AERMET for meteorological data processing and AERMAP for digital terrain processing) were used per EPA guidelines. Also, USEPA's AERMOD Implementation Guide dated September 27, 2005 was used in developing appropriate land use parameters for the model.

The regulatory default option was used (MODELOPT keyword in CO pathway) in the analysis per USEPA guidelines. The defaults options include:

- Use of elevated terrain algorithms requiring input of terrain data;
- Use of stack tip downwash (except for building downwash cases);
- Use of calms processing routines; and
- Use of missing data processing routines.

Since the site was considered rural, the default option of using a 4-hour life for exponential decay of SO₂ for urban sources was not relevant.

AERMOD requires several types of input data such as source emissions and locations (Source parameters), meteorological data, land use data and receptor data for simulation of impact of emissions sources on ambient air. These input parameters are discussed in following sections.

3.2 Source Parameters

The emission points considered under various scenarios in the air dispersion modeling have been listed in Section 2.2. All of the proposed emission points were point sources with identified stacks venting the emissions to the atmosphere. This section describes the parameters required in AERMOD for point sources and the procedure for estimating the parameters.

Emission Rates: Emission rates were calculated using manufacturer's data where available. If not available, then USEPA's AP-42 emission factor database was used. For SO₂, mass balance was used considering all sulfur bearing compounds converted 100 percent to SO₂. The details of the calculations are included in Appendix A. Table 3-1 summarizes the emission rates of modeled pollutants used in the analyses. For both gas turbines and flares, the short-term and annual average emission rates were the same and both set of control devices were used at full capacity of the units except for one flare possible used a 30 percent capacity to support the turbine operating scenario. These types of equipment typically run at full capacity since landfill gas generation can not be controlled. The CO emission rate was considered for 50 percent load for reasons explained in Section 3.2 below.

Table 3-1: Modeled Emission Rates

Pollutant	Averaging Period	Enclosed Flares ¹ (lb/hr)	Open Flares ² (lb/hr)	LFG Turbines ³ (lb/hr)
NOx	Annual	5.4	6.7	31.1
CO	1-Hour	18.0	36.6	31.3
	8-Hour	18.0	36.6	31.3
SO ₂ Interim	3-Hour	176.2	193.8	-
	24-Hour	176.2	193.8	-
	Annual	176.2	193.8	-
SO ₂ BACT	3-Hour	12.1	13.4	16.2
	24-Hour	12.1	13.4	16.2
	Annual	12.1	13.4	16.2
PM ₁₀	24-Hour	1.4	1.5	2.2
	Annual	1.4	1.5	2.2

Notes:

1. For Interim and Back-up BACT scenarios only
2. For Routine and Back-up BACT scenario only
3. For Routine BACT scenario only

Stack Gas Parameters: Stack gas parameters included: i) stack gas exit temperature, and ii) stack gas exit velocity. These are discussed separately.

Stack gas exit temperatures for the enclosed flares and the turbines were obtained from manufacturer's information. For open flares, stack gas exit temperature could not be measured and was a function of the degree and rate of entrainment of ambient air in the flared gases. Ohio Environmental Protection Agency (OEPA) and Texas Commission on Environmental Quality (TCEQ) have guidelines for estimating stack gas temperature and flow rate from open industrial flares. Upon review, it was determined that the OEPA guidelines were more conservative and therefore it was used for the estimation of stack gas temperature. A copy of the guideline (Engineering Guide #69) is included in Appendix A. The guide assumed stack gas temperature of 1273 degrees Kelvin (K) for industrial flares.

Stack exit velocities for enclosed flares were obtained from stack gas flow rates and stack diameters. Stack gas flowrate for enclosed flares were obtained from combustion calculations of landfill gas flow rate through the flares and approximately at 230% excess air conditions, typical of enclosed landfill gas flares. Stack gas velocity for turbines was obtained from manufacturer's data. As per OEPA guide on flares described above, stack exit velocity of all open flares were considered as 20 meters per second (m/s).

Physical Stack Parameters: Physical stack parameters included: i) stack height, stack diameter; and stack location (coordinates). For enclosed flares and combustion turbines, the stack height and diameters were obtained from manufacturer's information.

The physical stack diameter and height were not considered (for air dispersion modeling purposes) for the open flares, as per the OEPA guide. Instead virtual stack diameter and stack height were calculated to be used for air dispersion modeling purposes. The virtual stack diameter was calculated from a buoyant flux based on a default stack temperature of 1273 K, a stack gas flow rate based on the buoyant flux, and the stack diameter based on a default stack exit velocity of 20 m/s. The virtual stack height was calculated as a function of total heat release in combustion of the gas. Details of the calculations are in Appendix A.

Stack coordinates for all flares and turbines were obtained from equipment layout and a digitized map of the facility. The stack locations were converted to NAD83 UTM coordinates for consistency with receptor coordinates. Table 3-2 shows the stack parameters used in the air dispersion modeling analysis.

Table 3-2: Modeled Stack Parameters

Control Device ID	Description	Location (UTM) Easting (m)	Location (UTM) Northing (m)	Stack Height (ft)	Stack Exit Gas Temperature (F)	Stack Velocity (ft/s)	Stack Diameter (ft)
CD001	Existing Enclosed Flare	530433.07	3023829.91	45	1,400	38.084	10.000
CD002	Existing	530433.07	3023836.01	45	1,400	38.084	10.000

**Air Quality Impact Analysis
Proposed Modification Construction
Okeechobee Landfill, Facility ID No. 0930104**

Control Device ID	Description	Location (UTM) Easting (m)	Location (UTM) Northing (m)	Stack Height (ft)	Stack Exit Gas Temperature (F)	Stack Velocity (ft/s)	Stack Diameter (ft)
	Enclosed Flare						
CD003	Utility Flare 1 (backup)	530433.07	3023842.11	62.85	1,831.73	65.616	5.729
CD004	Utility Flare 2 (odor)	530433.07	3023848.2	62.85	1,831.73	65.616	5.729
CD005	Utility Flare 3	530433.07	3023854.3	62.85	1,831.73	65.616	5.729
CD006	Utility Flare 4	530433.07	3023860.39	62.85	1,831.73	65.616	5.729
CD007	Utility Flare 5	530433.07	3023866.49	62.85	1,831.73	65.616	5.729
CD008	Utility Flare 6	530433.07	3023872.59	62.85	1,831.73	65.616	5.729
CD009	Utility Flare 7	530433.07	3023878.68	62.85	1,831.73	65.616	5.729
CD010	Utility Flare 8	530433.07	3023884.78	62.85	1,831.73	65.616	5.729
CD011	Turbine 1	530470.48	3023713.24	50	894	58.68	8.371
CD012	Turbine 2	530470.48	3023719.33	50	894	58.68	8.371
CD013	Turbine 3	530470.48	3023725.43	50	894	58.68	8.371
CD014	Turbine 4	530470.48	3023731.53	50	894	58.68	8.371
CD015	Turbine 5	530470.48	3023737.62	50	894	58.68	8.371
CD016	Turbine 6	530470.48	3023743.72	50	894	58.68	8.371
CD017	Turbine 7	530470.48	3023749.81	50	894	58.68	8.371

3.3 Load Analysis

For many emission points, the operating load has impact on the emissions and also on the stack gas parameters. As such, the ambient impact might vary at different loads. For the proposed emission points, this analysis was relevant only for the combustion turbines, in which emission rates for CO and NOx varied at varying loads. The flares were considered to operate always at full load as per common practice in landfills, and therefore, the flares were not included in load analysis.

The analysis was conducted at 100%, 75%, and 50% of the operating load for a single turbine. Estimated stack gas flow parameters and emission rates were obtained from the manufacturers. The analysis was performed using USEPA's SCREEN3 model (version 96043). Technically, with USEPA's discontinuation of the ISCST3 model, the SCREEN3 model was also discontinued by USEPA, and a new screening level model AERSCREEN was to be used instead. However, USEPA did not issue a final version of AERSCREEN at the time of this report. With concurrence from FDEP, the SCREEN3 model was used therefore in this screening level analysis.

The results of the analysis are shown in Table 3-3. Model runs are included in Appendix D. While NOx impacts were highest at full load, carbon monoxide was determined to have maximum ground-level impact at partial load of 50%. This operating load was considered for CO in subsequent air dispersion modeling analysis.

Table 3-3: Load Analysis for LFG Turbines

Pollutant	Averaging Period	100% Load (ug/m ³)	75% Load (ug/m ³)	50% Load (ug/m ³)
NOx	1-hour	28.73	18.17	12.99
CO	1-hour	29.15	21.06	39.53

3.4 *Building Downwash Analysis*

A Good Engineering Practice (GEP) stack height evaluation was conducted for the buildings and structures near the emission points to determine the potential for aerodynamic downwash. The analysis followed the guidance established in USEPA's Guidelines for Determination of Good Engineering Practice Stack Height (USEPA 1995a). The procedure is described in the following section.

As per "Guidelines for Determination of Good Engineering Practice Stack Height" (USEPA, 1995a), the maximum horizontal extent (H_x) of the aerodynamic downwash from a building/structure (in meters) is given by:

$$H_x = 5L$$

where,

- H_x = Maximum horizontal extent of aerodynamic downwash in meters
- L = Lesser of the height of the building/structure (H_b) and maximum projected width (W_p) in meters.

The maximum projected width of a rectangular building/structure is the diagonal. For a circular structure (such as cylindrical tanks, stacks), the maximum projected width is the diameter.

The next step of the analysis is to determine if the flare and turbine stacks were above the vertical extent of aerodynamic downwash from the buildings/structure, also known as the GEP stack height. This is the minimum height of a stack in the vicinity of buildings/structures to avoid aerodynamic downwash. The GEP stack height as expressed in the aforementioned USEPA document is:

$$H_g = H_b + 1.5L$$

where,

- H_g = GEP Stack height in meters
- H_b = Height of building/structure in meters
- L = Lesser of the height or maximum projected width of the building/structure in meters.

The buildings used in the analysis are shown in Table 3-4. Locations of these buildings are shown in Figure 2-2. There were no appreciable structures at the site for aerodynamic downwash.

Table 3-4: Buildings/Structures Considered for Aerodynamic Downwash

Building Name	Southwest Corner UTM (Northing/Easting) (m)	Building Height (m/ft)	Building Length (m)	Building Width (m)
Turbine Building	530468.95 / 3023710.19	7.62/25	126	58
Maintenance Building	530397.28 / 3023696.5	7.62/25	31	29

The building downwash potential was analyzed using USEPA's Building Profile Input Program (BPIP) version 04274 which using the latest PRIME algorithms. The output of the BPIP-PRIME is included in Appendix D. The output was integrated in the AERMOD input file to account for building downwash.

3.5 Meteorological Data

Five years of preprocessed meteorological data from the nearest representative National Weather Service (NWS) station was received from FDEP for use in this analysis. The surface data was for latest five years 2001-2005 from West Palm Beach Airport (Station ID: 12844) and upper air data was for the same period from West Palm Beach Airport (Station ID: 92830). The locations of the meteorological stations are shown in Figure 3-1. As directed by FDEP, Shaw used the pre-processed data for the analysis.

From information gathered from FDEP, AERMET (version 06341) was used for processing the meteorological data. Wind roses for each year of surface meteorological data are shown in Figures 3-2A to 3-2F. The data capture was determined to be 99.1% in 2001, 99.1% in 2002, and 100% for 2003-2005. Since these data capture meets EPA goals of at least 90%, no further data filling was performed.

The AERMET pre-processor requires the user to specify land use based parameters such as albedo, bowen ratio, and surface roughness. These values are typically used for each season and various wind sectors. FDEP determined that seasonal values were not practical for south Florida and therefore single values were used for all seasons. Sector averaged values used by FDEP for these parameters are included in the AERMET processed file sent to Shaw for the modeling analysis.

3.6 Receptor Layout

FDEP guidance was followed in generating receptor grids to determine the maximum impact of proposed source emissions on ambient air quality. The receptors used in the analysis were as follows:

Property Line Receptors:

These receptors were located all along the property boundary of the facility at a 100 meters spacing. The receptor layout is graphically shown in Figures 3-3A to 3-3D.

Preliminary Impact Analysis Receptors:

A Cartesian grid was used for locating receptors outside the property boundary for the preliminary analysis in determining the significance of impact of pollutants from the proposed emissions points. The receptor coverage utilized for this analysis consisted of the following:

- 100-meter spaced receptors to a distance of 500 kilometers from the fenceline (fine grid),
- 250-meter spaced receptors to a distance of 1000 meters from the fenceline (fine grid),
- 500-meter spaced receptors to a distance of 5000 meters from the fenceline (medium grid),
- 1000-meter spaced receptors to a distance of 10000 meters from the fenceline (medium grid), and
- 5000-meter spaced receptors beyond distance of 10000 meters from the fenceline (coarse grid).

A total of approximately 3600 receptors were included in this analysis.

The United States Geological Service (USGS) digital elevation maps (DEM) data for terrain within 50 kilometers of the facility were based on the NAD83 datum and in UTM Zone 17. Therefore, the NAD83 datum was used for the receptor UTM coordinates. Bowman Environmental Inc.'s "BEE-Line BEEST for Windows, V9.55" was used for calculating (interpolating) the terrain elevations for this analysis

The receptor layout is graphically shown in Figure 3-3A to 3-3D.

Full Impact Analysis Receptors:

The AAQS and PSD increment compliance demonstrations are required only at locations where the proposed project could potentially have equal to or greater than significance concentration from proposed emission points. In order to reduce computation time (for 3600 receptors and five years of meteorological data), these significance level receptors identified during the preliminary impact analyses were separated in a receptor file and used for refined analyses for AAQS and PSD compliance demonstration. The separate receptor files were used for each pollutant since the significance levels and significance level area coverage were different for each pollutant. As described later in Section 4.0, only NO₂ and SO₂ required full impact analysis. Figures 3-4A through 3-4D show the significance level receptors used in refined analysis for NO₂ and SO₂ for the Routine BACT Scenario. Figures 3-5A through 3-5D show the significance level receptors used in the refined analysis for NO₂ and SO₂ for the Back-up BACT Scenario.

3.7 *NO_x to NO₂ Conversion*

The NO_x emission rates were used in the air dispersion modeling. Since the AAQS and PSD increments are based on NO₂, the national default NO_x to NO₂ conversion factor of 75 percent was applied to the predicted impacts at receptors.

3.8 *Terrain Data*

The terrain data was processed with AERMAP, a preprocessor of AERMOD modeling system. Digital elevation maps (DEMs) of 7.5 minute quadrangle was used for area of 25 km from the source in all directions in the AERMAP, which developed characteristics of the planetary boundary layer (PBL) based on similarity theory. The heights of receptors were not required to be input in AERMOD separately.

4.0 Air Quality Analysis

This section contains the results of the ambient air quality impacts analyses. All modeling input and output files are included in electronic form on computer disks supplied as Appendix D in this report.

The details of the analysis are included in following sections. In summary, results of this modeling analysis revealed no anticipated adverse effects resulting from this project. There were no exceedances of Federal and FDEP standards as demonstrated in the AAQS analysis and PSD Class II increment analysis. In addition, the project was not expected to have an adverse effect on growth, animals, vegetation, soils, or visibility.

4.1 Preliminary Analysis

In the preliminary analysis, the impact of the proposed emission points on ambient air quality was estimated to determine if these pollutants has "significance level" impact, which required full impact analysis. The analysis was also used to determine if pre-application monitoring was required for the project.

The preliminary analysis includes emissions from proposed modification only. For the Interim scenario, three new open flares were considered for the preliminary analysis. For the Back-up BACT operating scenario, the emissions from proposed modification, eight (8) new open flares, were considered in the analysis. For the routine BACT operating scenario, the two existing enclosed flares each at 3,000 scfm (total 6,000 scfm) would be replaced by seven (7) new LFG turbines each at 4,000 scfm, an one open flare at 3,300 scfm and an open flare operating at 30-percent capacity at 1,100 scfm for a total fuel throughput of 32,400 scfm. The existing flares will be on-site as emergency but will not run under this turbine BACT scenario (If they do run due to a outage in the turbines, their emission rates for all criteria pollutants, with the exception of CO, are lower than the turbines on a scfm of LFG basis):

Thus, the new emissions are from additional 26,600 scfm (32,400 scfm – 6,000 scfm). Thus, the net emission change (projected allowable or potential – baseline actual) is calculated as follows:

$$E_{net} = E_{BACT} - E_{existing}$$

Where

E_{net} = Net emission increase

E_{BACT} = Potential emissions from 7 turbines and 1.3 new flares, total 32,400 scfm LFG

And for the pollutant CO:

E_{BACT} = Potential emissions from 8 new open flares, total 32,400 scfm LFG

$E_{existing}$ = Actual emissions from 2 existing flares, total 6,000 scfm LFG

The emission increases and decreases are from two different types of sources (turbines vs. flares) which are located at two different locations in the facility; so the net emission increase could not be used directly in the model. Since the preliminary analysis is used for determination of ambient impact only, the following method was used in the preliminary analysis.

- AERMOD was run with 7 new turbines and 1 new flare with their full potential emissions and 1 new flare operated at 30-percent capacity (i.e. at total E_{BACT}); and
- In the same run, the existing flares were added as negative emission points with total negative emissions equal to $E_{existing}$

This way, we will have the net ambient impact of the net emissions and we will compare that with the "significance level" concentrations. Concurrence from FDEP was obtained for this approach.

Table 4-1 summarizes the maximum predicted ground-level concentrations (H1H) and the corresponding PSD/AAQS significance concentration levels for all pollutants for the interim scenario, the routine BACT scenario, and the back-up BACT scenario, respectively.

Preliminary modeling results predicted CO and PM10 concentrations below the significance levels for all three scenarios. The maximum predicted off-property SO₂ (3-hour, 24-hour, and annual) concentrations were greater than respective significance level concentrations for all the three operating scenarios. The maximum predicted off-property NO₂ (annual) concentration was greater than respective significance level concentrations for the Routine BACT and Back-up BACT scenarios. Refined modeling analyses were conducted for these pollutants.

Table 4-1: Significance Analysis Results

Scenario	Pollutant	Averaging Period	Maximum Predicted Concentration (H1H)	PSD/AAQS Significance Level	Exceeds Significance Level Concentration?	Area of Significant Impact (AOI)
			µg/m ³	µg/m ³	Yes/No	km
Interim ⁽¹⁾	NO ₂	Annual	0.79	1	No	NA
	CO	1-Hour	71.53	2000	No	NA
		8-Hour	56.61	500	No	NA
	PM10	24-Hour	1.74	5	No	NA
		Annual	0.24	1	No	NA
	SO ₂	3-Hour	346.39	25	Yes	12.4
		24-Hour	224.18	5	Yes	19.6
Annual		30.60	1	Yes	7.2	
Routine BACT	NO ₂	Annual	6.60	1	Yes	2.6
	CO	1-Hour	135.89	2000	No	NA
		8-Hour	108.52	500	No	NA
	PM10	24-Hour	4.73	5	No	NA
		Annual	0.62	1	No	NA
	SO ₂	3-Hour	56.30	25	Yes	1.1
		24-Hour	34.53	5	Yes	2.5
Annual		4.52	1	Yes	1.7	

Scenario	Pollutant	Averaging Period	Maximum Predicted Concentration (H1H)	PSD/AAQS Significance Level	Exceeds Significance Level Concentration?	Area of Significant Impact (AOI)
			µg/m ³	µg/m ³	Yes/No	km
Backup BACT	NO ₂	Annual	2.09	1	Yes	1.1
	CO	1-Hour	188.35	2000	No	NA
		8-Hour	151.97	500	No	NA
	PM10	24-Hour	4.70	5	No	NA
		Annual	0.62	1	No	NA
	SO ₂	3-Hour	62.86	25	Yes	1.1
		24-Hour	41.95	5	Yes	2.5
Annual		5.58	1	Yes	1.7	

⁽¹⁾ The results of interim scenario are provided per request of FDEP and for informational purposes only

4.2 Pre-Application Monitoring Requirement Analysis

The preliminary analysis results were also used to determine if pre-application monitoring was required for the pollutant which exceeded the significance level concentration, namely NO₂ and SO₂. The monitoring data is used to develop background concentrations for determination of compliance with AAQS. Pre-application monitoring is required if: i) maximum off-site predicted concentration exceeds PSD monitoring significance concentration and ii) there are no monitoring data available in the modeling region.

Table 4-2 summarizes the maximum predicted ground-level concentrations (H1H) and compares them with the PSD monitoring significance levels for the interim, routine BACT and back-up BACT scenarios, respectively. The results indicated that only SO₂ (24-hour average) was above the monitoring significance level for all three operating scenarios. However, pre-application monitoring was not required for these pollutants because several monitoring sites were available in the modeling region and extensive monitoring data were available from these monitors. The issue of background monitoring concentration is separately discussed in Section 4.4.

Table 4-2: PSD Monitoring Requirement Analysis Results

Scenario	Pollutant	Averaging Period	Maximum Predicted Concentration (H1H)	PSD Monitoring Significance	Above Significance Level?
			µg/m ³	µg/m ³	Yes/No
Interim ⁽¹⁾	NO ₂	Annual	0.79	14	No
	PM10	24-Hour	1.74	10	No
	CO	8-Hour	56.61	575	No
	SO ₂	24-Hour	224.18	13	Yes
Routine BACT	NO ₂	Annual	6.60	14	No
	PM10	24-Hour	4.73	10	No
	CO	8-Hour	108.52	575	No
	SO ₂	24-Hour	34.53	13	Yes
Back-up BACT	NO ₂	Annual	2.09	14	No

**Air Quality Impact Analysis
Proposed Modification Construction
Okeechobee Landfill, Facility ID No. 0930104**

	PM10	24-Hour	4.70	10	No
	CO	8-Hour	151.97	575	No
	SO ₂	24-Hour	41.95	13	Yes

⁽¹⁾ The results of interim scenario are provided per request of FDEP and for informational purposes only

The Facility is located in the federally designated Southeast Florida Intrastate Air Quality Control Region and is currently in attainment of all ambient air quality standards. Ambient air quality data for Florida are available from a monitoring network operated by the Florida Department of Environmental Protection (FDEP), Division of Air Resource Management. Monitoring data on the criteria pollutants are collected at many sites within the state. These monitoring data are obtained for the years 2004 through 2006 from the DEP "Quick Look Reports" web site.

The monitoring station in Riviera Beach, Palm Beach County was used for SO₂, background data as it is the most representative of the Okeechobee Landfill due to its relative proximity to the station compared to all other stations. The monitoring station in Fort Pierce, St. Lucie County was used for NO₂ background data. These were the closest monitoring sites to Okeechobee.

The highest annual average and highest second highest short term average concentrations (i.e. 3, and 24 hours) for the period 2004 through 2006 were used to obtain the necessary background pollutant concentrations for this analysis. These background concentrations are shown in Table 4-3.

Table 4-3: Background Concentrations Used for AAQS Analysis

Pollutant	Averaging Period	Background Concentration (µg/m ³)
NO ₂	Annual	20.95
SO ₂	3-Hour	8.57
SO ₂	24-hour	8.57
SO ₂	Annual	3.43

Notes: The background concentrations for SO₂ and NO₂ were obtained from FDEP monitoring stations in Riviera Beach, Palm Beach County and Fort Pierce, St. Lucie County, respectively.

4.3 Full Impact Analysis

Guidance from the USEPA's *Guidance on Air Quality Models* (40 CFR 51, Appendix W) was followed in selecting the predicted concentrations used to determine compliance with the AAQS and PSD increment consumption limits. The guidelines state that "the design concentration based on the highest, second-highest short term concentration or the highest long term concentration...should be used to determine emission limitations to assess compliance with the AAQS and PSD increments" for SO₂, PM10, CO, Pb, and NO₂ (§8.2.1.1). Therefore, the "2nd" highest output was selected for the short-term analysis and the "1st" highest output was selected for the annual analyses. Table 4-4 shows the design concentration used for the various analyses.

Table 4-4: Design Concentrations for Full Impact Analyses

Pollutant	Refined Model	Averaging Time	Design Concentration
SO ₂	AAQS	3-hr	H2H ⁽¹⁾
		24-hr	H2H
		Annual	H1H ⁽²⁾
SO ₂	Increment	3-hr	H2H
		24-hr	H2H
		Annual	H1H
NO ₂	AAQS	Annual	H1H
	Increment	Annual	H1H

⁽¹⁾ H2H = Highest of 2nd high of each of 5 years of meteorological data

⁽²⁾ H1H = Highest of 1st high of each of 5 years of meteorological data

4.3.1 Full Impact Analysis Receptors

The AAQS and PSD increment compliance demonstrations are required only at locations where the proposed project could potentially have equal to or greater than significance concentration from proposed emission points. In order to reduce computation time (for 3,600 receptors and five years of meteorological data), these significance level receptors identified during the preliminary impact analyses were separated in a receptor file and used for refined analyses for AAQS and PSD compliance demonstration. The separate receptor files were used for each pollutant since the significance levels and significance level area coverage were different for each pollutant. Figures 3-4A through 3-4D show the significance level receptors used in refined analysis for NO₂ and SO₂.

4.3.2 PSD Class II Increment Compliance Demonstration

For the full impact analysis, the model included: i) the proposed emission sources; ii) the existing on-site sources; and iii) off-site PSD increment inventory sources. The Facility has no existing sources of SO₂ and NO₂ emissions except for the two enclosed flares used for interim operating scenario and back-up BACT operating scenario. There are few small generators in the Facility with capacity ranging from 20 kilowatt (kW) to 360 kW, which are operated infrequently. The emissions of SO₂ and NO₂ from these generators are insignificant to the flares and LFG turbines. Per discussions with FDEP, these emission sources were not required to be included in the modeling.

The off-site PSD source inventory was obtained from FDEP and is included in Appendix C. Per guidance from FDEP, all emission sources in this inventory with allowable source emissions in tons per year less than 20 times the distance in km (i.e. E <20D) were eliminated from the modeling since these emission sources would have insignificant impact in the modeling domain. The revised off-site PSD source inventory is also included in Appendix C. The FDEP database also provided the source parameter and location for these emission sources.

Table 4-5 shows the emission sources modeled for PSD Class II increment compliance for the various operating scenarios. The interim scenario was modeled per request of FDEP and for informational purposes only.

Table 4-5: Emission Sources Modeled for PSD Class II Increment Compliance

Scenario Modeled	New Emission Sources in Proposed modification	Existing On-site Emission Sources	Off-Site AAQS Inventory Emission Sources	Off-Site PSD Inventory Emission Sources
Interim	Three new open flares (CD004 to CD006)	Two enclosed flares (CD001 and CD001)	8 SO ₂ emission sources from FDEP inventory (10 SO ₂ sources for 24-hr averaging time)	5 SO ₂ emission sources from FDEP inventory (7 SO ₂ sources for 24-hr averaging time)
Routine BACT	7 LFG Turbines (CD011 to CD017); 2 open flares (CD003 and CD004)	None	8 SO ₂ and 8 NO _x emission sources from FDEP inventory	5 SO ₂ and 5 NO _x emission sources from FDEP inventory
Back-up BACT	8 proposed open flares (CD003 to CD010)	Two enclosed flares (CD001 and CD002) operating with BACT limits	8 SO ₂ and 8 NO _x emission sources from FDEP inventory	5 SO ₂ and 5 NO _x emission sources from FDEP inventory

The results of the modeling are shown in Table 4-6 for the interim operating scenario, the routine BACT operating scenario, and the back-up BACT operating scenarios, respectively. The details of the model runs are included in Appendix D. The results showed that PSD Class II increments were not exceeded for any pollutant for any averaging time in both BACT scenarios. The PSD Increment was exceeded in the 24-hour and annual averaging times for SO₂. *This scenario is temporary and listed here for informational purposes only.*

Table 4-6: PSD Increment Consumption Analysis Results

Scenario	Pollutant	Averaging Period	Maximum Predicted Concentration from Increment Consuming Project and Non-Project Sources	PSD Increment Consumption Limit	Percent of PSD Increment Consumed at Maximum Concentration	Exceed PSD Increment?	
			□g/m ³	□g/m ³	%	Yes/No	
Interim ¹	SO ₂	3-Hour ³	465.67	512	90.9	No	
		24-Hour ³	285.79	91	314.0	Yes	
		Annual ²	41.55	20	207.7	Yes	
Routine BACT	NO ₂	Annual ²	8.46	25	33.8	No	
	SO ₂	3-Hour ³	52.99	512	10.34	No	
		24-Hour ³	33.53	91	36.8	No	
Back-up BACT	SO ₂	Annual ²	5.60	20	28.0	No	
		NO ₂	Annual ²	3.12	25	12.5	No
		3-Hour ³	65.77	512	12.8	No	
Back-up BACT	SO ₂	24-Hour ³	41.00	91	45.0	No	
		Annual ²	6.70	20	33.5	No	

(1) The results of interim scenario are provided per request of FDEP and for informational purposes only

(2) H1H annual results

(3) H2H results

4.3.3 AAQS Compliance Demonstration

The AAQS modeling was similar to the PSD increment modeling except that: i) AAQS inventory emission sources obtained from FDEP were used instead of PSD inventory emission sources; and ii) background concentration was added to modeled concentration for comparison with AAQS.

As explained in Section 4.2, pre-application monitoring was not conducted for the project since adequate data were available for background concentration. The background concentrations used for AAQS compliance demonstrations are shown in Table 4-3 above.

Table 4-7 shows the results of AAQS modeling for the interim operating scenario, the routine BACT operating scenario, and the back-up BACT operating scenario, respectively. The results show that the AAQS was not exceeded for any pollutant for any averaging time in both BACT scenarios. The AAQS was exceeded in the 24-hour averaging time for SO₂. *This scenario is temporary and listed here for informational purposes only.*

Table 4-7: AAQS Analysis Results

Scenario	Pollutant	Averaging Period	Maximum Predicted Concentration from Project and Non-Project Sources	Background Concentration	Maximum Predicted Concentration from Project, Non-Project, and Background Sources	AAQS	Percent of AAQS at Location of Maximum Concentration	Exceed AAQS with Monitored Concentrations ?
			□g/m ³	□g/m ³	□g/m ³	□g/m ³	%	Yes/No
Interim ¹	SO ₂	3-Hour ³	465.68	8.57	474.25	1300	36.5	No
		24-Hour ³	285.79	8.57	294.36	260	113.2	Yes
		Annual ²	41.63	3.43	45.06	60	75	No
Routine BACT	NO ₂	Annual ²	8.72	20.95	29.66	100	29.7	No
	SO ₂	3-Hour ³	52.99	8.57	61.56	1300	4.73	No
		24-Hour ³	33.53	8.57	42.10	260	16.2	No
		Annual ²	5.68	3.43	9.11	60	15.2	No
Back-up BACT	NO ₂	Annual ²	3.38	20.95	24.32	100	24.3	No
	SO ₂	3-Hour ³	65.78	8.57	74.35	1300	5.7	No
		24-Hour ³	41.01	8.57	49.58	260	19.1	No
		Annual ²	6.78	3.43	10.21	60	17.0	No

(1) The results of interim scenario are provided per request of FDEP and for informational purposes only

(2) H1H annual results

(3) H2H results

5.0 Additional Impact Analysis

The additional impact analyses include: i) Class I area impact analysis for visibility and AQRVs; ii) analysis of growth in the significant impact area and its effect on air quality; iii) impact of proposed modifications on soils, vegetation, and wildlife in the significant impact area; and iv) impact on visibility in the significant impact area. These analyses are described in this section.

5.1 Class I Area Air Quality Analysis

Class I areas are areas of special national or regional value from a natural, scenic, recreational, or historic perspective. Adverse impacts on Class I areas are prevented by:

- iii) Ensuring that Class I area increments are not exceeded; and
- iv) Ensuring that the air quality related values (AQRVs) in the Class I areas are not significantly affected.

Typically, Class I area within 100 km of the proposed source or modification is considered in the analysis. Currently, due to current emphasis in improving visibility in Class I areas via the Regional Haze Rule, Class I areas at greater distances are also being included in the analysis.

The Federal Class I area nearest to the source is the Everglades National Park in South Florida, Located approximately 169 kilometers from the facility's southern most property line. The Biscayne Bay National Park is a Class II area; however, it is considered important relative to air pollution impacts and is also considered in the analyses.

The Class I area air quality analysis is conducted in two phases as follows:

- iv) Significant Impact Analysis: the net emissions increase from project is used in determining the air quality impact in the Class I area and is then compared to the Class I area significance level concentration. The Draft New Source Review Workshop Manual (1990) lists Class I significance level concentration as 1 ug/m³ for 24-hour average for all pollutants with NAAQS. USEPA has subsequently proposed lower significance level concentrations. The proposed levels have not been officially promulgated as part of the PSD review process. However, FDEP has accepted the use of these significance level concentration for Class I areas.

If the project's air quality impact does not exceed the Class I significance level concentration, then no further air quality analyses is required.

- v) Class I area Increment and AQRV Analysis: These analyses are needed if the project's air quality impact exceeds the Class I area significance level concentration. The impact from the project can not be exceed the Class I PSD increments.
- vi) AQRV Analysis: The AQRV analysis is required for submission to Federal land Managers (FLM) who are charged with affirmative responsibility to protect the

AQRVs. The AQRVs vary with the Class I area being considered. Based on discussions with the National Park Service (NPS), the AQRVs to be considered for the Everglades NP and Biscayne Bay NP are: i) deposition of total nitrates and sulfates; ii) visibility degradation; and iii) impact of ozone on vegetations. The results of these analyses are submitted to NPS for AQRV analyses. Since the VOC emissions (PSD surrogate for ozone) did not exceed the significant emission rate, ozone impact assessment is not required for this project.

The CALPUFF modeling system, with associated processors such as CALMET, CALPOST and POSTUTIL, were used for the Class I area impact analysis. Both the routine BACT and back-up BACT scenarios were modeled. The modeling followed USEPA and NPS guidance in following documents:

- Interagency Workgroup on Air Quality Models (IWAQM) Phase 2 Summary report in Modeling Long Range Transport Impacts (USEPA,1998), commonly referred to as IWAQM Phase 2 Report;
- Federal Land Manager's Air Quality Related Values Workgroup, Phase I Report (12/00), commonly referred to as the FLAG Document.

Meteorological data was received from FDEP in MM5 format for 2001, 2002, and 2003 for the subdomain 5 of VISTAS, in which the source and the receptors are located.

The results of the modeling indicated that:

- The ambient air quality impacts were less than both the current and proposed the Class I significance level concentrations. Thus, Class I PSD increment analysis was not required.
- The total nitrogen and total sulfate depositions for all years were lower than the NPS deposition analysis threshold (DAT) of 0.01 Kg/ha-yr
- The visibility impairment was less than 5% of the background in all 24-hour periods in 2001, 2002, and 2003.

5.2 Growth Analysis

Rule 62.212.400(3)(h)(5), F.A.C. requires an in-depth growth analysis in a PSD permitting review if the project is expected to result in significant shifts in population or if it could result in population increases on the order of thousands within the areas of significant impact of the project's emissions. The proposed project will be implemented over a period of 50 years and is not expected to create jobs sufficient to trigger the requirement for an in-depth growth analysis and is not expected to significantly increase the emissions of air contaminants from secondary sources. No additional industrial, commercial or residential growth is expected from this project, which will require 1 or 2 personnel only for operation of the new equipment. Neither any additional mobile source emissions are expected due to the proposed emission sources. Therefore, no air quality impact is predicted from the growth associated with the project.

Rule 62.212.400(3)(h)(5), F.A.C. also requires the application to include air quality impacts of, and the nature and extent of general, residential, commercial, industrial, and other growth that

has occurred since August 7, 1977, in the area the modification would affect. As shown in the Figures 3-4 and 3-5, the area of impact from this modification is only few kilometers from the facility boundary. This is primarily rural farmland with no other residential, commercial, industrial or other growth. Therefore, there is no air quality impact from growth in this area of impact.

5.3 Analysis of Impact on Soil Vegetation and Wildlife

According to USDA Soil Survey, three types of soils are found in the vicinity of the Facility: Terra Ceia muck, tidal; and Pennsuco marl, tidal. There are no significant urban developments in this area. The natural vegetations are black and red mangroves. There are no known wildlife or endangered species within the impact area from this proposed modification.

The background air concentration for SO₂ and NO₂ are both well below the secondary NAAQS levels. These levels will not be exceeded due to addition of the new sources in the proposed modification. Both the soils have high buffering capacity and are not expected to be impacted from the increased emissions from the proposed modification.

Similarly, no impact is expected on the vegetation in the significant impact area from the proposed modification.

5.4 Visibility Impairment Analysis

Visibility analysis for the Class I area is included in Section 5.1. This section describes the methodology and results of the visibility analysis within the impact area.

The flares and turbines will combust LFG that for the purposes of the analysis is approximately 50 percent methane, a clean burning gas and primary constituent of natural gas. The balance of LFG is carbon dioxide, which does not take part in combustion. A typical fuel analysis for LFG may be found in Appendix C of the Air Permit Application Report. Additionally, the flares and turbines will be in compliance with applicable opacity standards. Thus, no adverse visibility impairment in the impact area is predicted for the proposed modification.

6.0 Conclusions

Air quality impact analysis was performed for proposed modifications at the Okeechobee Landfill in Okeechobee County. The analysis included both PSD Class II increment and AAQS compliance demonstrations as well as additional impact analysis. Three operating scenarios were considered: i) interim operating scenario (for informational purposes only); ii) routine BACT operating scenario; and iii) back-up operating scenario.

USEPA approved model AERMOD was used for the analysis. The technical approach and modeling procedure followed USEPA approved methodology and FDEP instructions as needed.

In both routine and back-up operating scenarios, the Class II PSD increments and AAQS were not exceeded for any regulated pollutant. No adverse impact was predicted on soil, vegetation, wildlife and visibility in the impact area from this project.

Figures

Figure 2-1 Location of Okeechobee Landfill

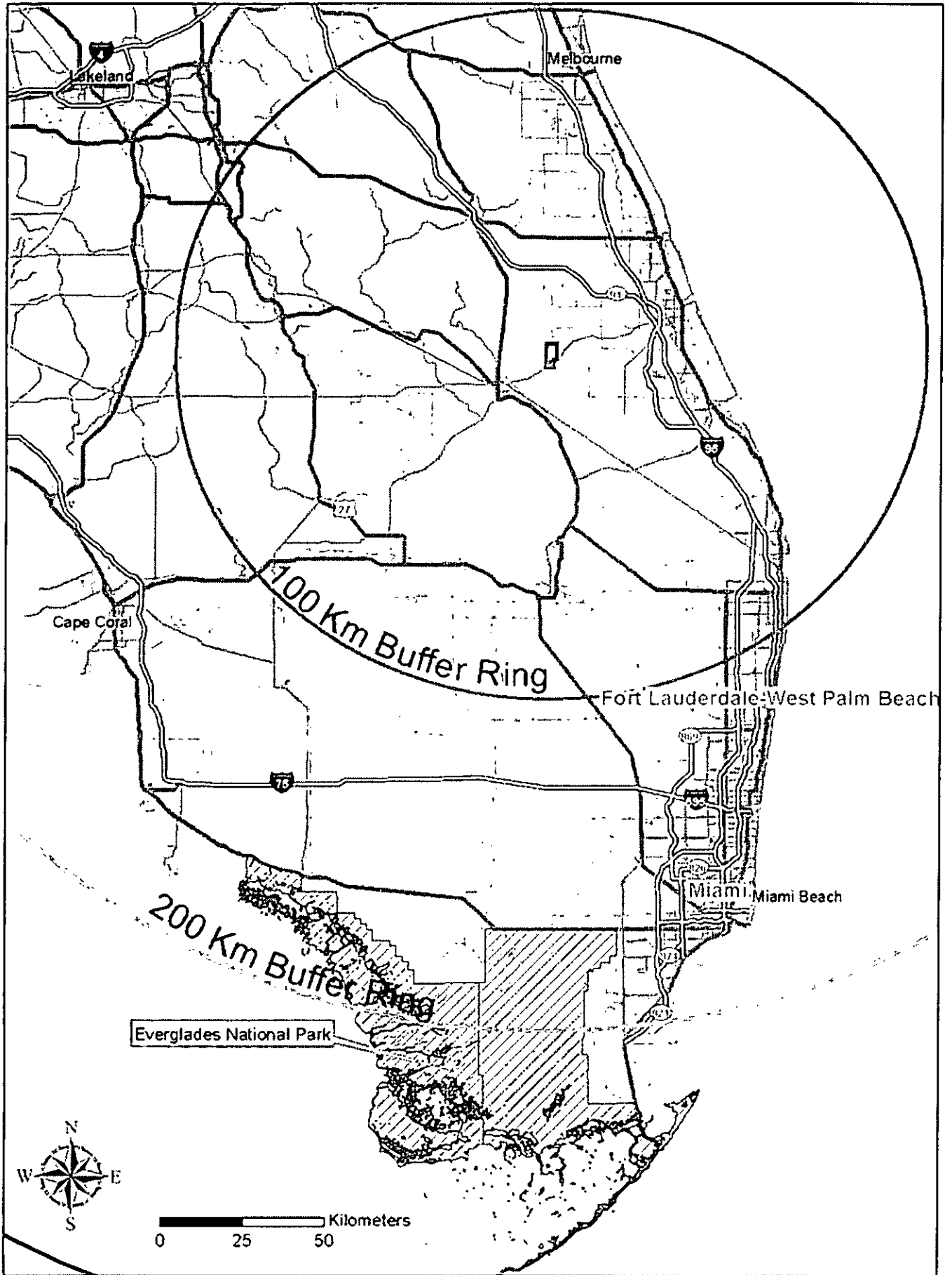

OFFICE	DATE	DESIGNED BY	DRAWN BY	CHECKED BY	APPROVED BY	DRAWING NUMBER
Pittsburgh, PA	--/--/--	--	--	--	--	121525-B14

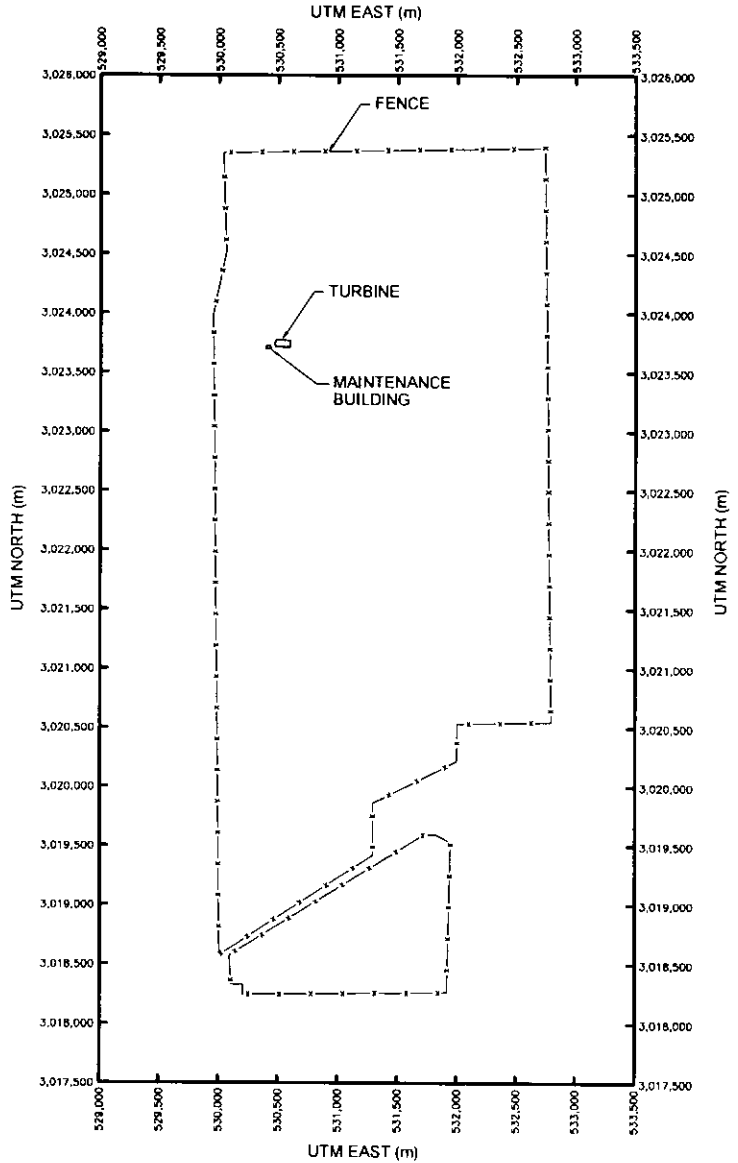

 Shaw Shaw Environmental, Inc.
OKEECHOBEE LANDFILL, INC. OKEECHOBEE, FLORIDA
FIGURE 2-2B BUILDING LOCATION OKEECHOBEE LANDFILL, INC. OKEECHOBEE, FLORIDA

Figure 3-1 Location of Meterological Station



WIND ROSE PLOT.
Okeechobee Landfill, Inc.
Okeechobee, FI

DISPLAY.
Wind Speed
Direction (blowing from)

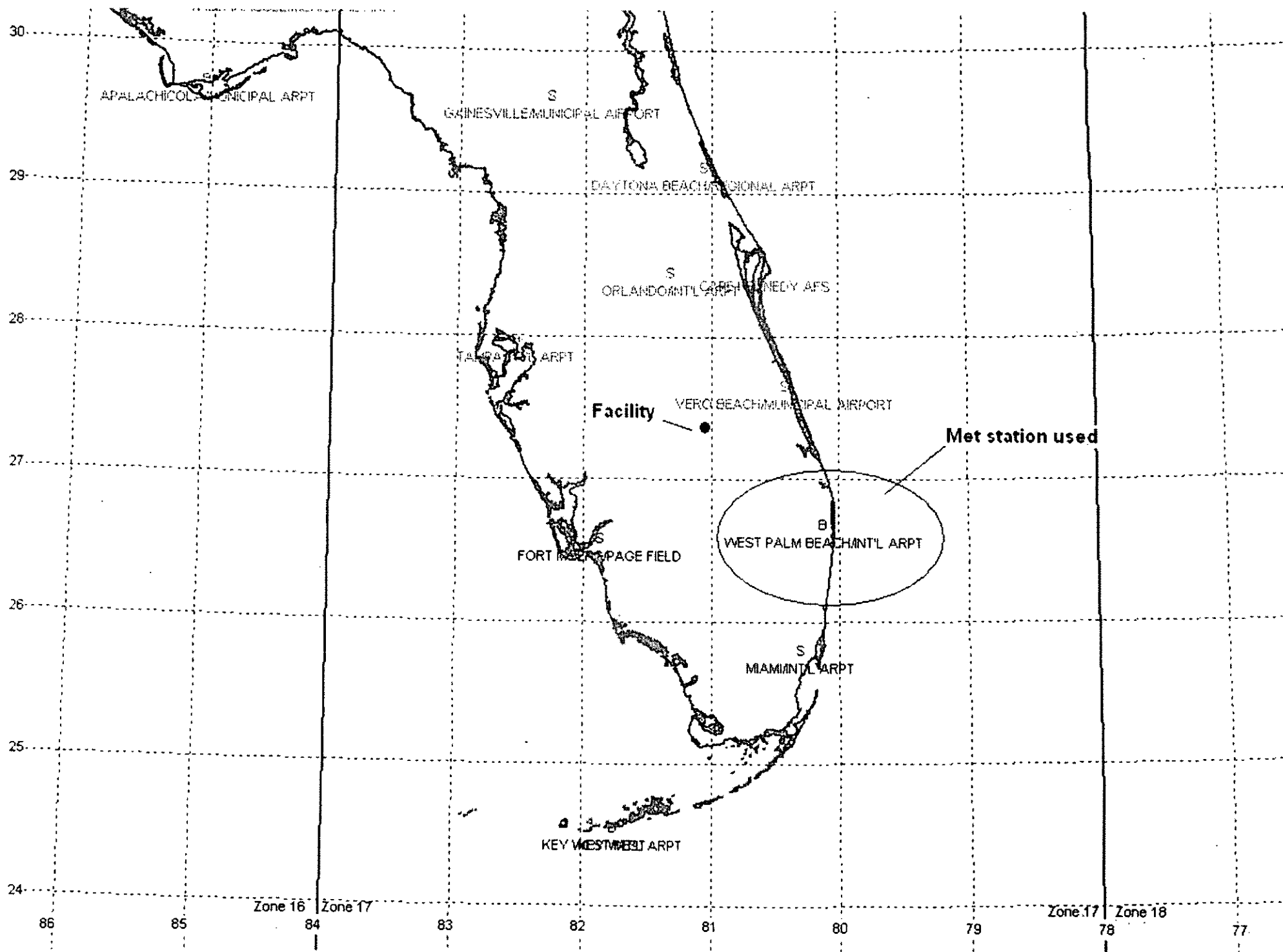
COMMENTS:

Figure 3-2A
 CY2001 Windrose

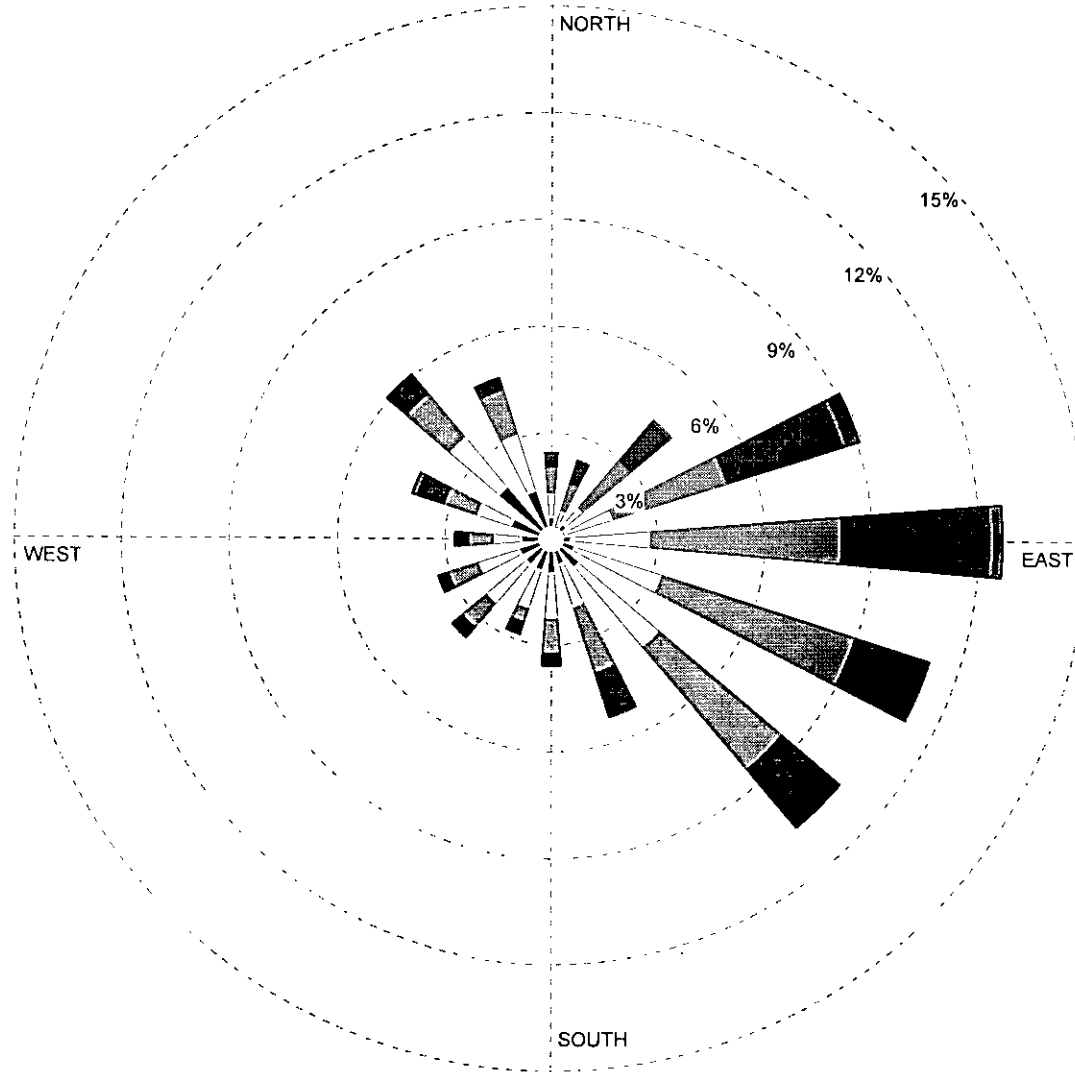

WIND SPEED
 (Knots)

- >= 22
- 17 - 21
- 11 - 17
- 7 - 11
- 4 - 7
- 1 - 4

Calms: 10.57%

CALM WINDS:

10.57%

AVG. WIND SPEED:

7.86 Knots

COMPANY NAME:

Okeechobee Landfill, Inc.

MODELER:

Shaw E & I, Pittsburgh, PA

DATE:

2/13/2007

PROJECT NO.:

121525

WIND ROSE PLOT:
Okeechobee Landfill, Inc.
Okeechobee, FI

DISPLAY:
Wind Speed
Direction (blowing from)

COMMENTS:

Figure 3-2B
 CY2002 Windrose

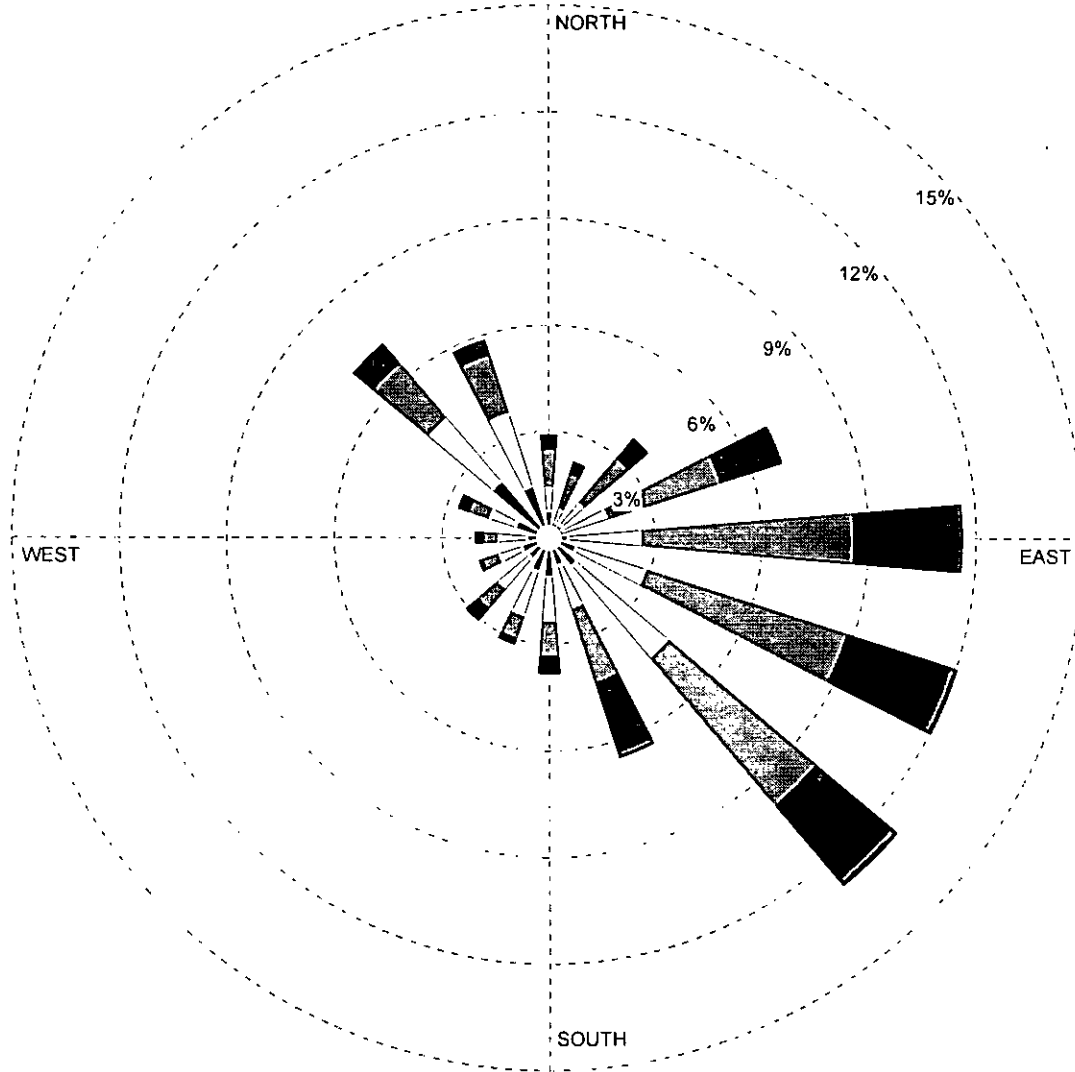

WIND SPEED
 (Knots)

- >= 22
- 17 - 21
- 11 - 17
- 7 - 11
- 4 - 7
- 1 - 4

Calms: 11.46%

CALM WINDS:
11.46%

AVG. WIND SPEED:

7.55 Knots

COMPANY NAME:

Okeechobee Landfill, Inc.

MODELER:

Shaw E & I, Pittsburgh, PA

DATE:

2/13/2007

PROJECT NO.:

121525

WIND ROSE PLOT:

**Okeechobee Landfill, Inc.
Okeechobee, FL**

DISPLAY:

**Wind Speed
Direction (blowing from)**

COMMENTS:

Figure 3-2C
CY2003 Windrose

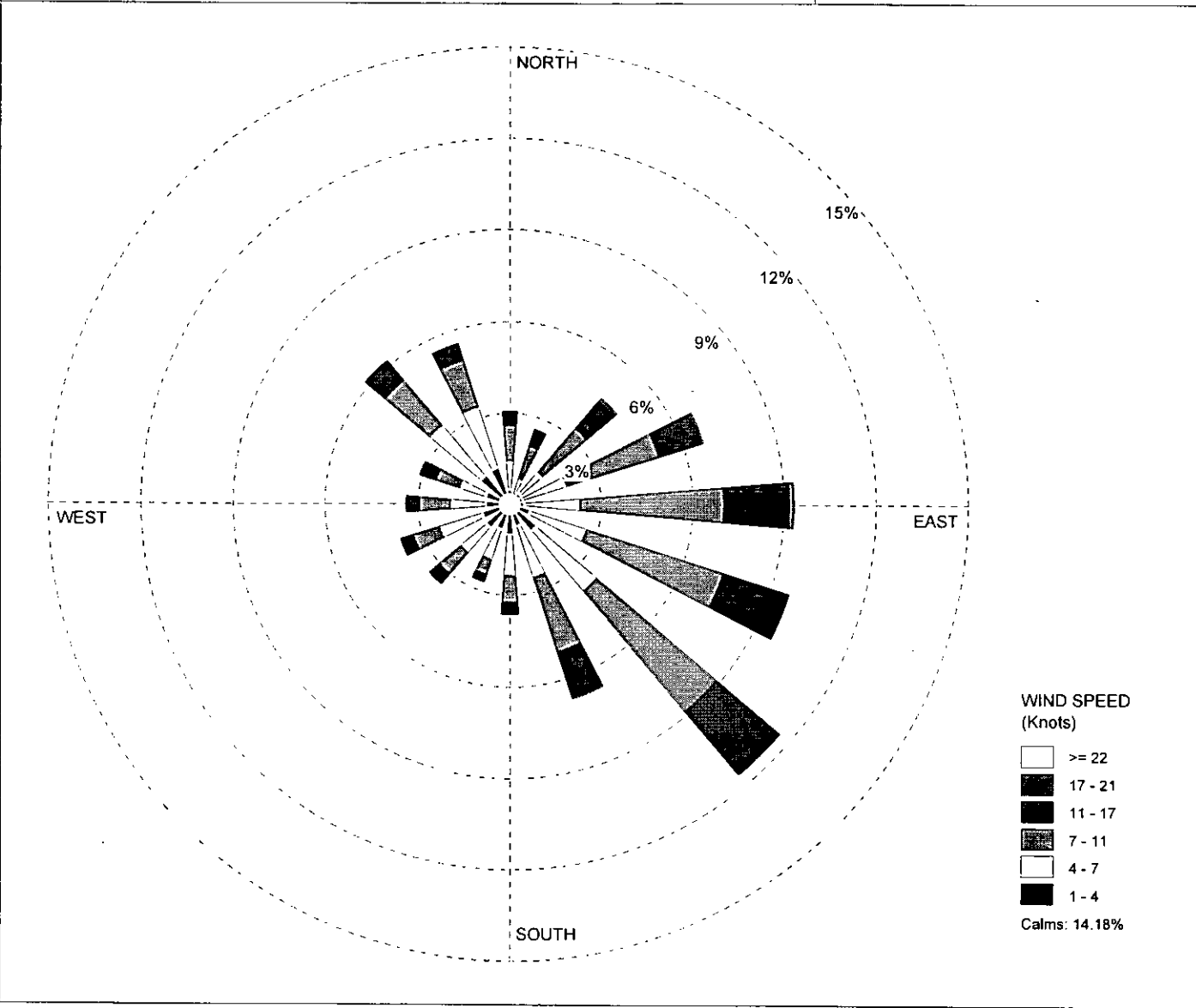

CALM WINDS:

14.18%

AVG. WIND SPEED:

7.31 Knots

COMPANY NAME:

Okeechobee Landfill, Inc.

MODELER:

Shaw E & I, Pittsburgh, PA

DATE:

2/13/2007

PROJECT NO.:

121525

WIND ROSE PLOT:

**Okeechobee Landfill, Inc.
Okeechobee, FI**

DISPLAY:

**Wind Speed
Direction (blowing from)**

COMMENTS:

Figure 3-2D
CY2004 Windrose

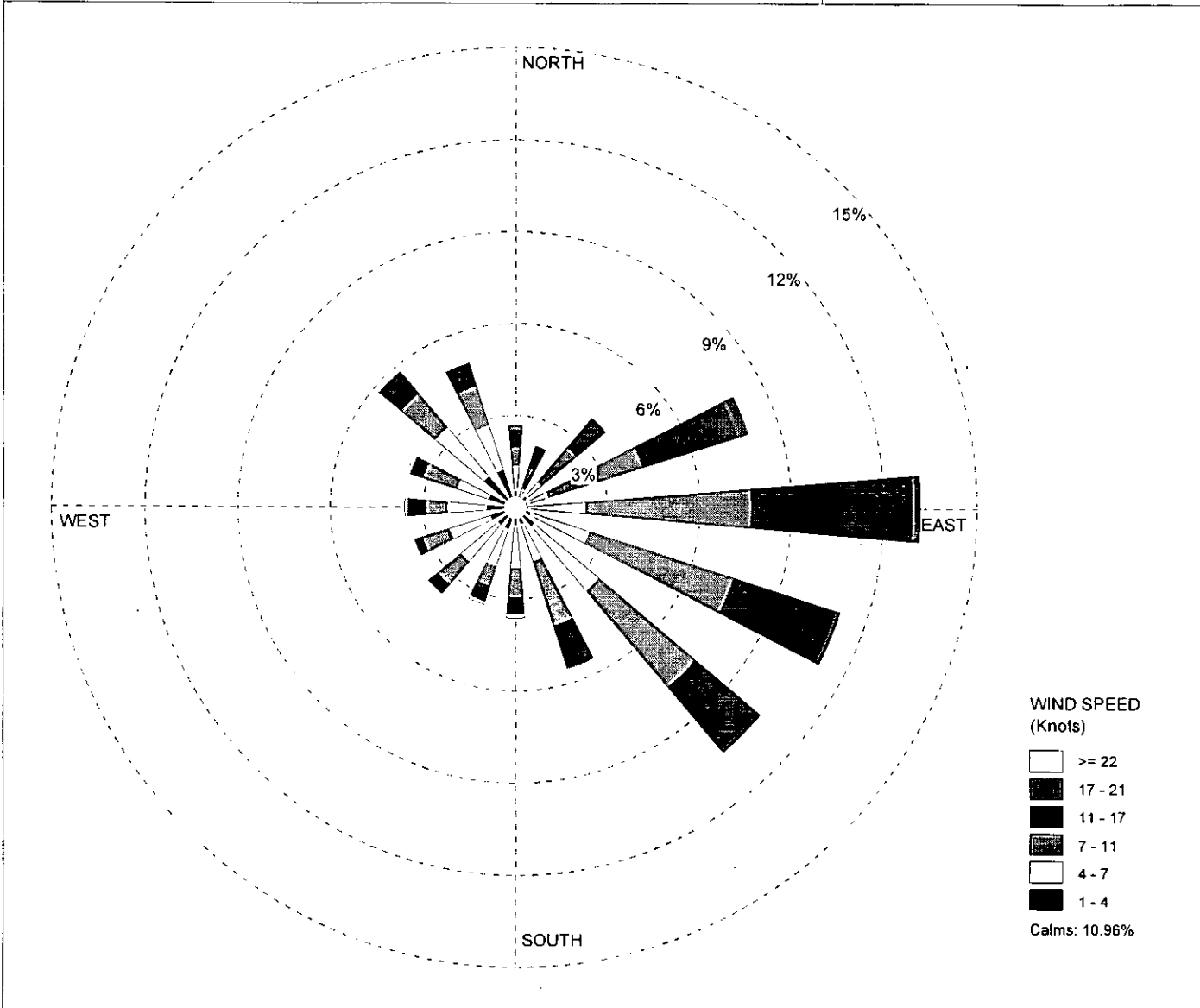

CALM WINDS:

10.96%

AVG. WIND SPEED:

8.28 Knots

COMPANY NAME:

Okeechobee Landfill, Inc.

MODELER

Shaw E & I, Pittsburgh, PA

DATE:

2/13/2007

PROJECT NO.:

121525

WIND ROSE PLOT:

**Okeechobee Landfill, Inc.
Okeechobee, FI**

DISPLAY:

**Wind Speed
Direction (blowing from)**

COMMENTS:

Figure 3-2E
CY2005 Windrose

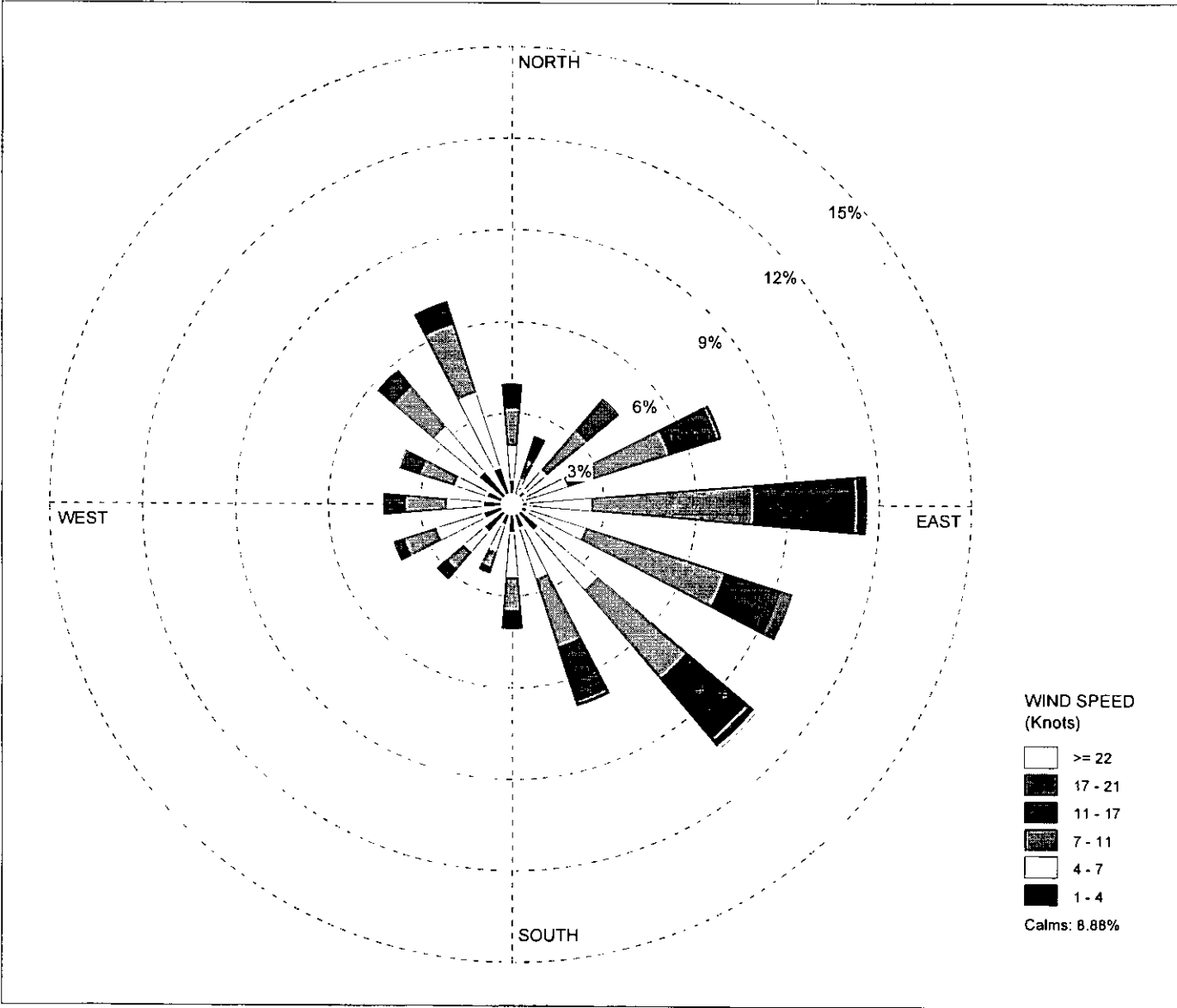

CALM WINDS:
8.88%

AVG. WIND SPEED:

8.02 Knots

COMPANY NAME:

Okeechobee Landfill, Inc.

MODELER:

Shaw E & I, Pittsburgh, PA

DATE:

2/13/2007

PROJECT NO.:

121525

WIND ROSE PLOT:
Okeechobee Landfill, Inc.
Okeechobee, FI

DISPLAY:
Wind Speed
Direction (blowing from)

COMMENTS:

Figure 3-2F
 Five-year Windrose

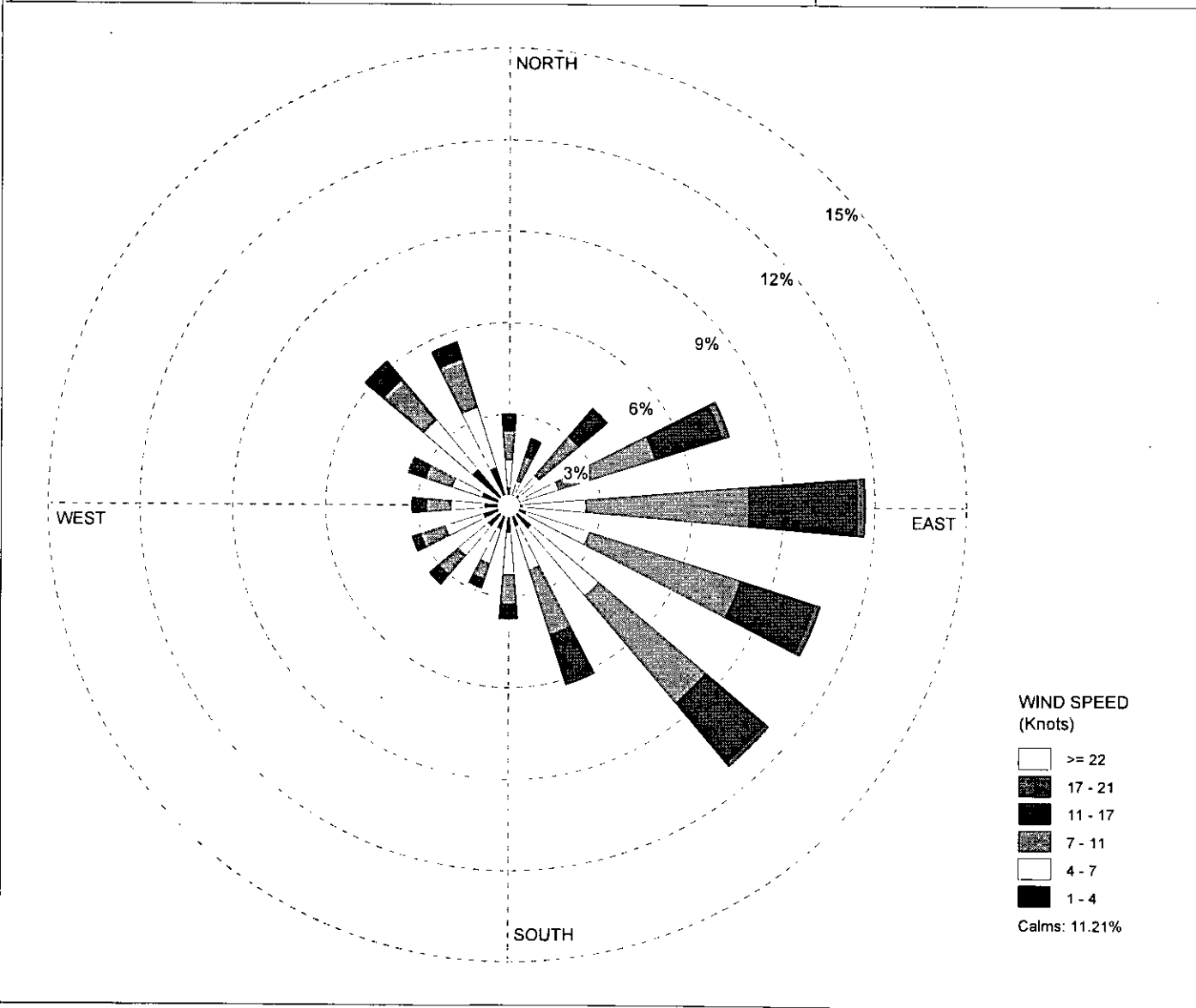

CALM WINDS:
11.21%

AVG. WIND SPEED:

7.80 Knots

COMPANY NAME:

Okeechobee Landfill, Inc.

MODELER:

Shaw E & I, Pittsburgh, PA

DATE:

2/13/2007

PROJECT NO.:

121525

PROJECT: 121525-B1
 DATE: 06/11/08
 DRAWN BY: [redacted]

OFFICE: Pittsburgh, PA
 DATE: --/--
 DESIGNED BY: --
 DRAWN BY: --
 CHECKED BY: --
 APPROVED BY: --
 DRAWING NUMBER: 121525-B1

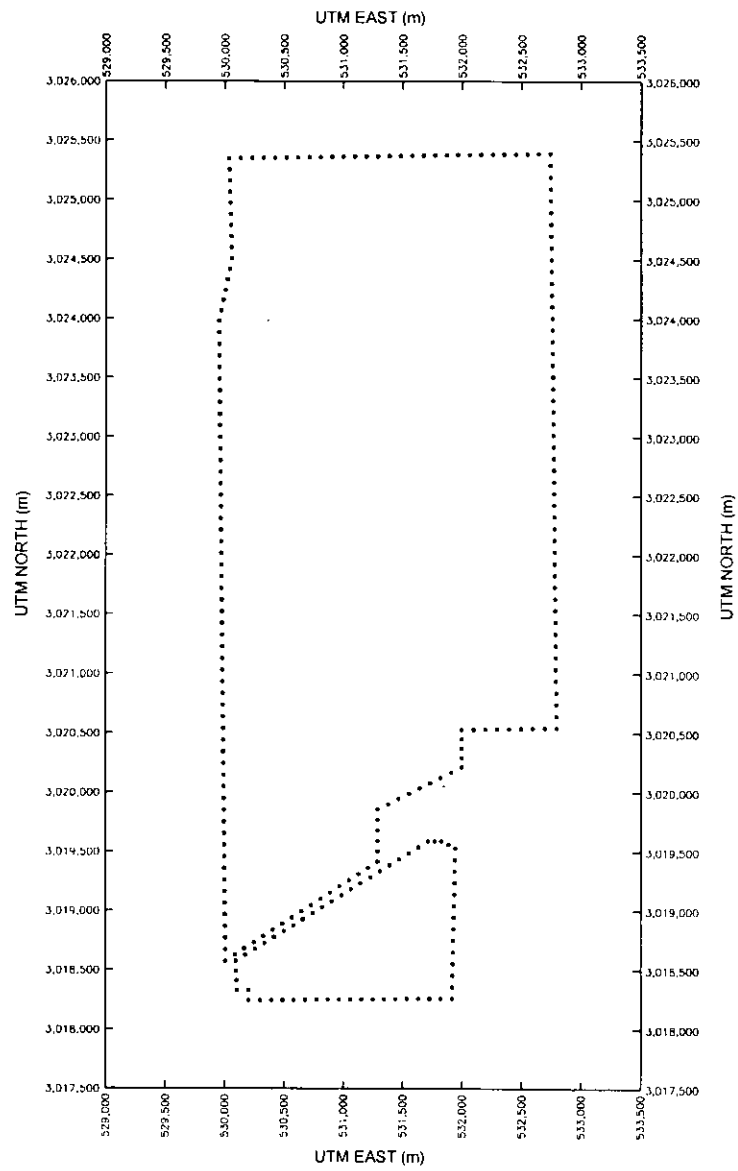

 Shaw Shaw Environmental, Inc.
OKEECHOBEE LANDFILL, INC. OKEECHOBEE, FLORIDA
FIGURE 3-3A RECEPTOR LOCATIONS FOR THE FENCE LINE GRID OKEECHOBEE LANDFILL, INC. OKEECHOBEE, FLORIDA

File: O:\Project\121525\121525B2.dwg
 Date/Time: Feb 22 2007 - 7:26am
 Plotter: plott1.mpl

OFFICE	DATE	DESIGNED BY	DRAWN BY	CHECKED BY	APPROVED BY	DRAWING NUMBER
RTI/abruph, PA	-/-/-					121525-B2

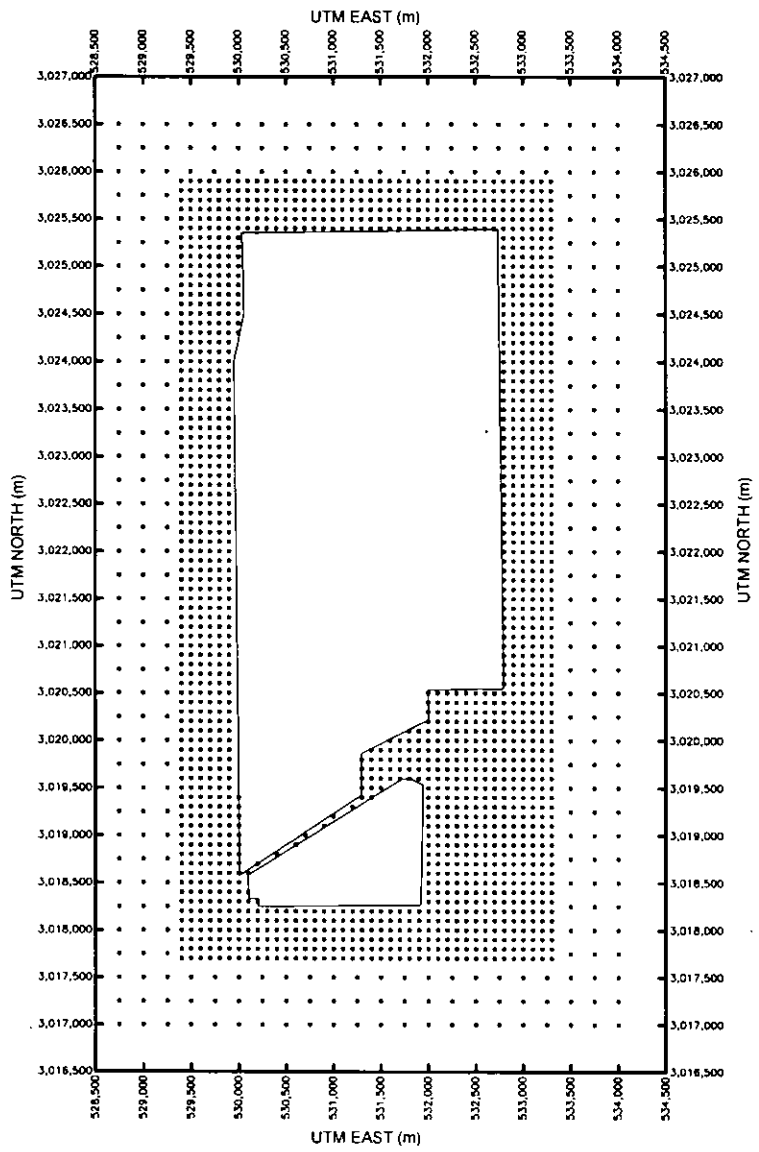



 Shaw Shaw Environmental, Inc.
OKEECHOBEE LANDFILL, INC. OKEECHOBEE, FLORIDA
FIGURE 3-3B RECEPTOR LOCATIONS FOR THE FINE GRID
OKEECHOBEE LANDFILL, INC. OKEECHOBEE, FLORIDA

File: C:\Projects\121525\12152501.dwg
 Plot Date: 02/22/2007 7:25am
 Plotted By: gns.jones

1:1
 mwp

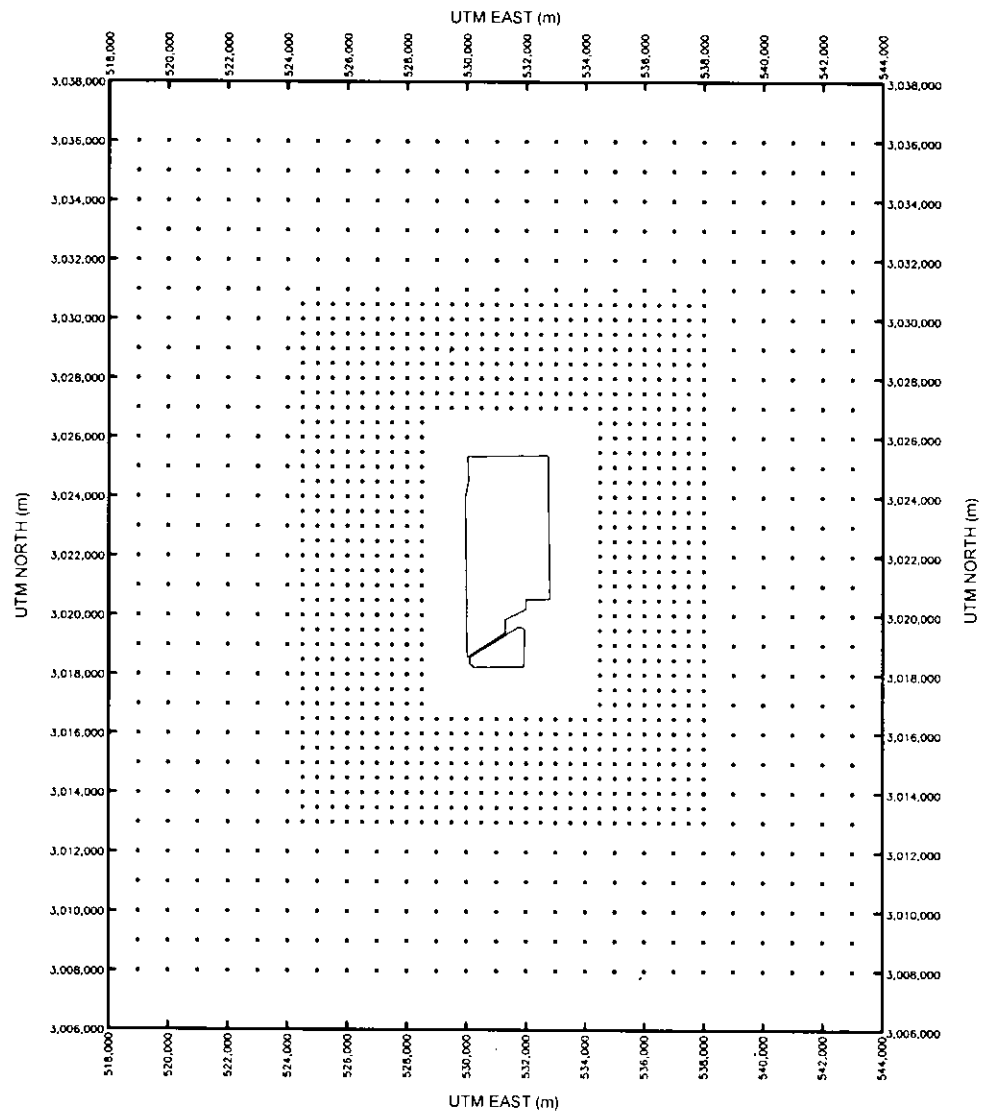
OFFICE	DATE	DESIGNED BY	DRAWN BY	CHECKED BY	APPROVED BY	DRAWING NUMBER
Pittsburgh, PA	--/--	--	--	--	--	121525-03





 Shaw Shaw Environmental, Inc.
OKEECHOBEE LANDFILL, INC. OKEECHOBEE, FLORIDA
FIGURE 3-3C RECEPTOR LOCATIONS FOR THE MEDIUM GRID
OKEECHOBEE LANDFILL, INC. OKEECHOBEE, FLORIDA

C:\Project\121525\121525.dwg
 12/22/2007 - 7:26am
 Plotted By: greg.jones

1 of 1 image

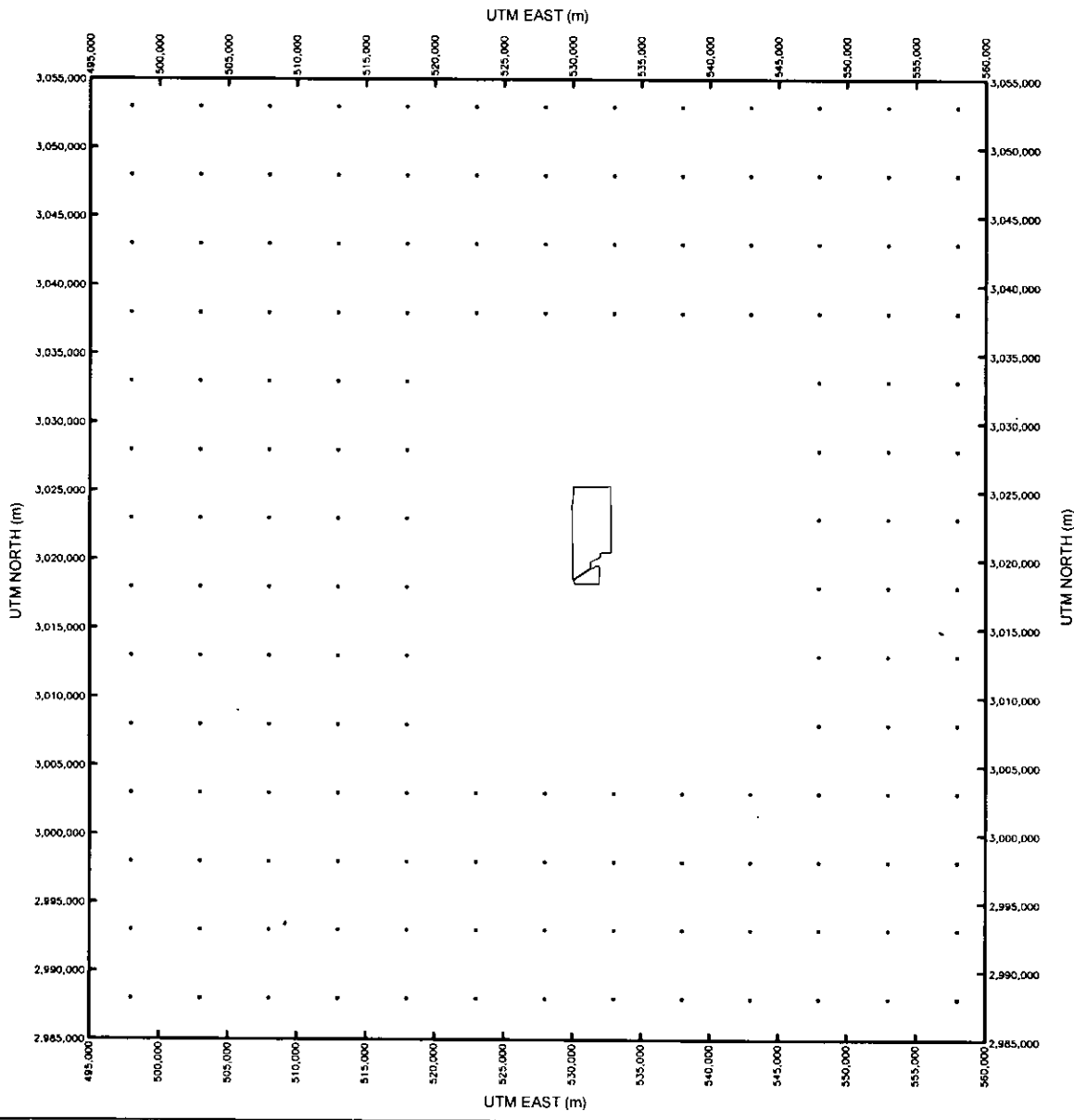
OFFICE: Pittsburgh, PA
 DATE: / /
 DESIGNED BY: / / / /
 DRAWN BY: / / / /
 CHECKED BY: / / / /
 APPROVED BY: / / / /
 DRAWING NUMBER: 121525-B4



 Shaw Shaw Environmental, Inc.
OKEECHOBEE LANDFILL, INC. OKEECHOBEE, FLORIDA
FIGURE 3-3D RECEPTOR LOCATIONS FOR THE COARSE GRID
OKEECHOBEE LANDFILL, INC. OKEECHOBEE, FLORIDA

OFFICE	DATE	DESIGNED BY	DRAWN BY	CHECKED BY	APPROVED BY	DRAWING NUMBER
Pittsburgh, PA	--/--/--	--	--	--	--	121525-B9

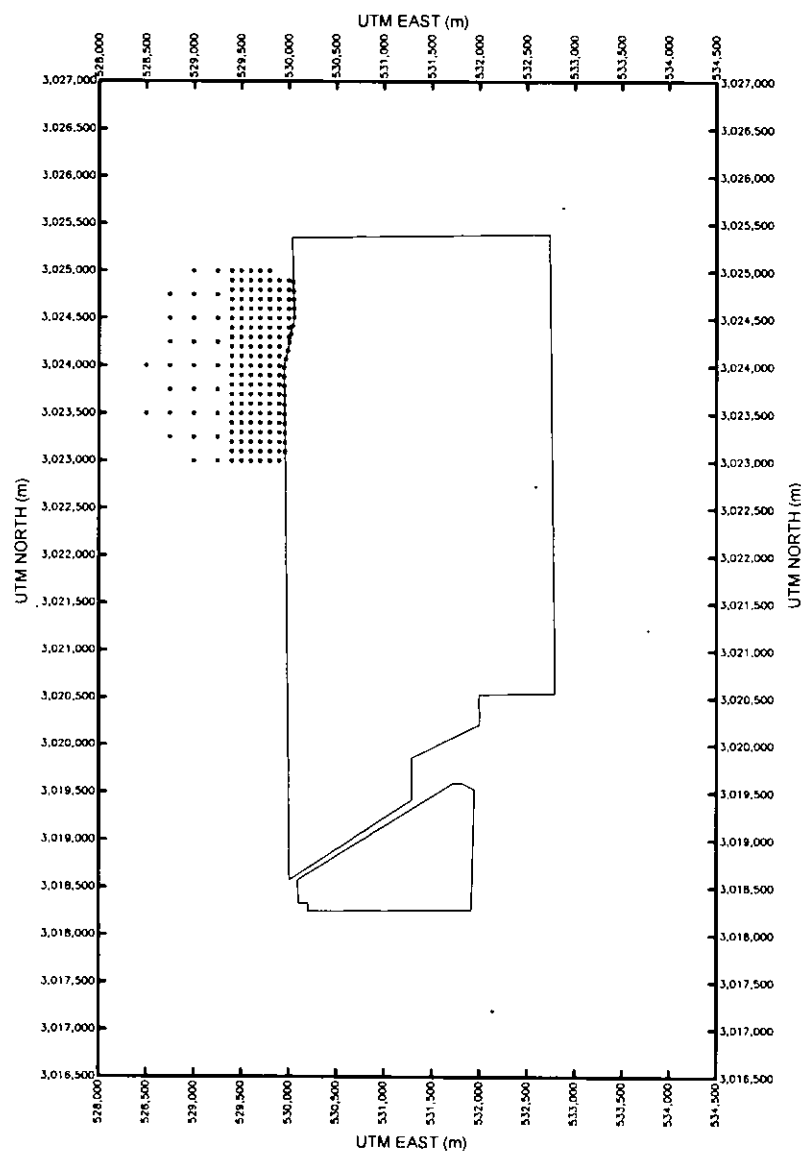



 Shaw Shaw Environmental, Inc.
OKEECHOBEE LANDFILL, INC. OKEECHOBEE, FLORIDA
FIGURE 3-4A NO2 ANNUAL SIGNIFICANCE RECEPTORS ROUTINE BACT OKEECHOBEE LANDFILL, INC. OKEECHOBEE, FLORIDA

F:\0\Project\121525\121525B10.dwg
 Plot Date/Time: Feb 22, 2007 - 7:32am
 Plotted By: greg.jones

Plot
 by greg.jones

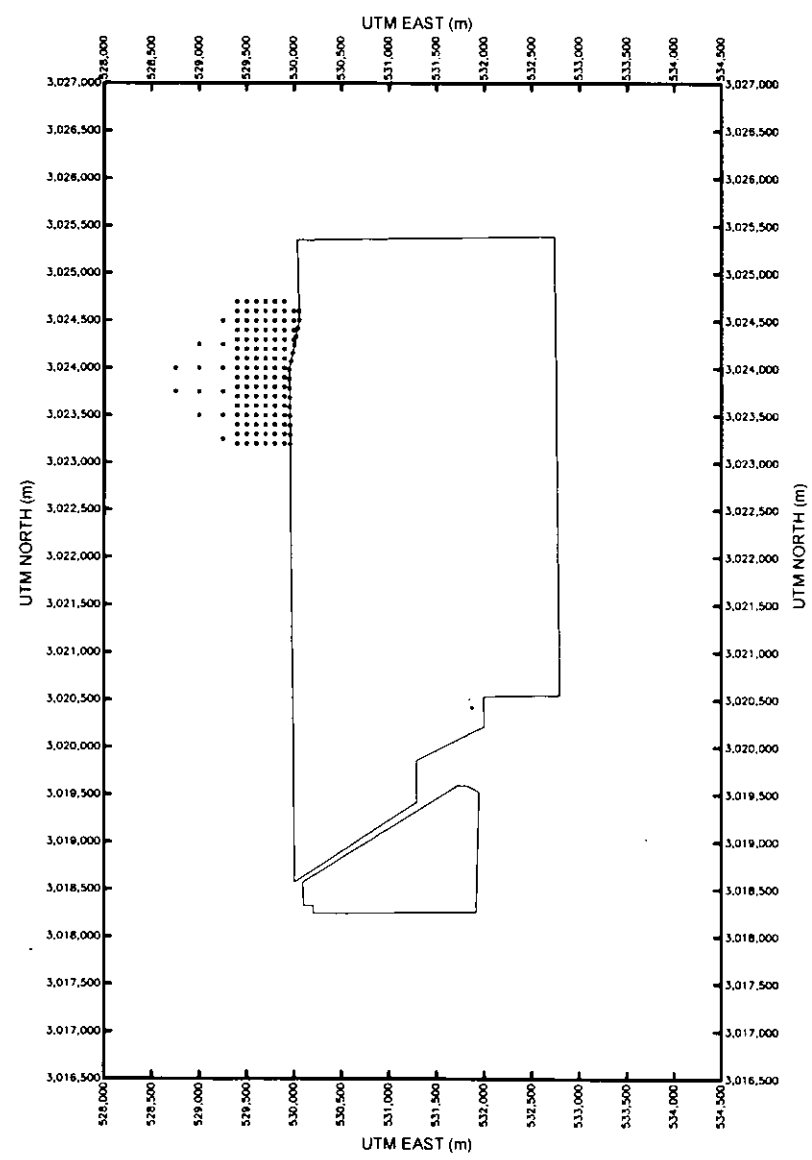
OFFICE	DATE	DESIGNED BY	DRAWN BY	CHECKED BY	APPROVED BY	DRAWING NUMBER
ENH/ENR/PA	-/-/---					121525-B10



 Shaw Shaw Environmental, Inc.
OKEECHOBEE LANDFILL, INC. OKEECHOBEE, FLORIDA
FIGURE 3-4B SO2 ANNUAL SIGNIFICANCE RECEPTORS ROUTINE BACT OKEECHOBEE LANDFILL, INC. OKEECHOBEE, FLORIDA

OFFICE	DATE	DESIGNED BY	DRAWN BY	CHECKED BY	APPROVED BY	DRAWING NUMBER
Princeton, PA	-/-/--	--	--	--	--	121525-B11

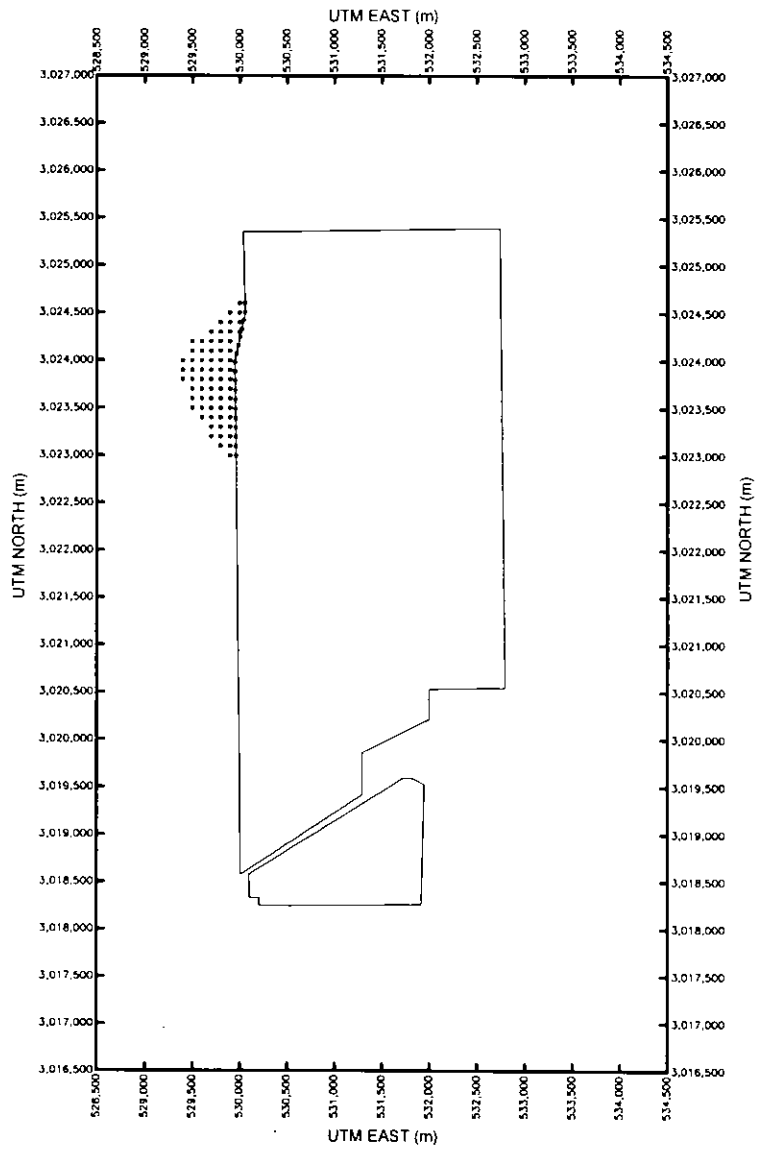



 Shaw Shaw Environmental, Inc.
OKEECHOBEE LANDFILL, INC. OKEECHOBEE, FLORIDA
FIGURE 3-4C SO2 3-HR. SIGNIFICANCE RECEPTORS ROUTINE BACT OKEECHOBEE LANDFILL, INC. OKEECHOBEE, FLORIDA

File: G:\Project\121525\121525B12.dwg
 Plot Date: Feb 22, 2027 - 7:54am
 Plot By: pgg/jam

Plot
 Page

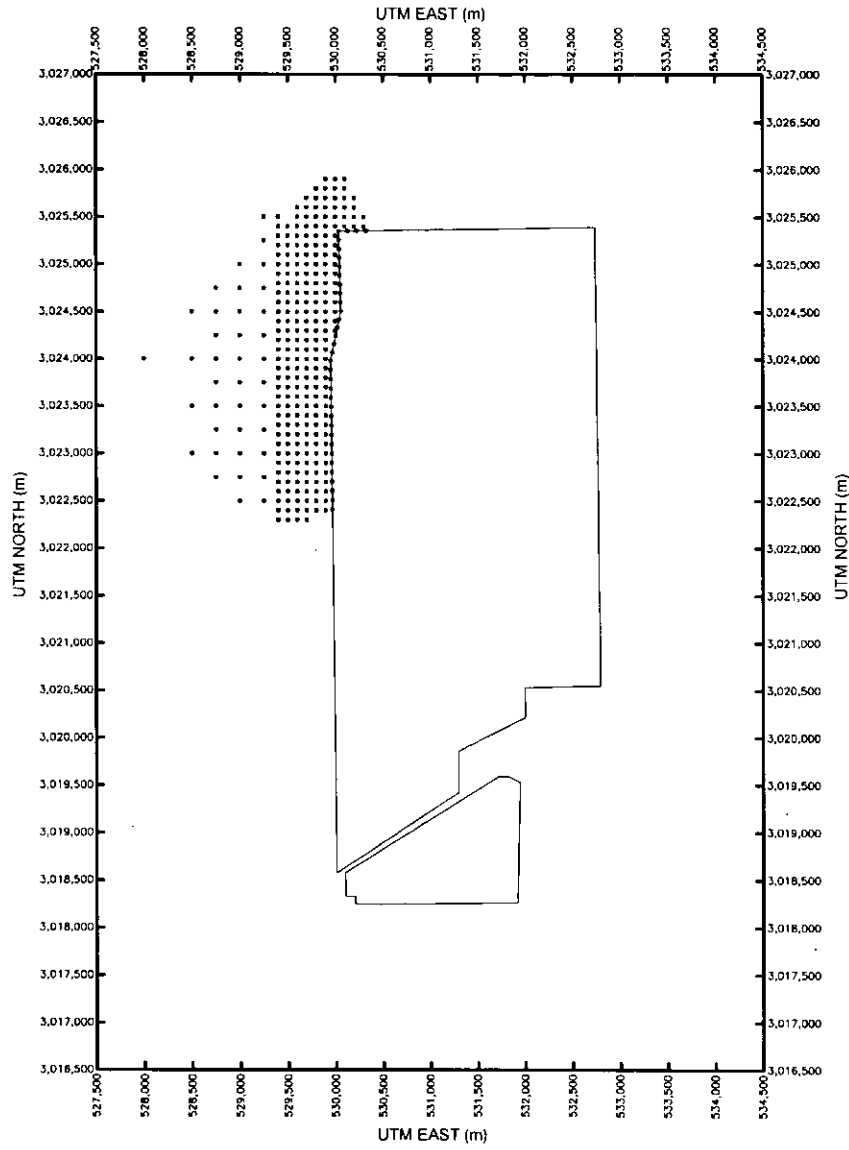
OFFICE	DATE	DESIGNED BY	DRAWN BY	CHECKED BY	APPROVED BY	DRAWING NUMBER
PHILADELPHIA, PA	-/-/-	-/-/-	-/-/-	-/-/-	-/-/-	121525-B12



 Shaw Shaw Environmental, Inc.
OKEECHOBEE LANDFILL, INC. OKEECHOBEE, FLORIDA
FIGURE 3-4D SO2 24-HR. SIGNIFICANCE RECEPTORS ROUTINE BACT OKEECHOBEE LANDFILL, INC. OKEECHOBEE, FLORIDA

File: G:\Projects\121525\121525B18.dwg
 Plot Date: 11/22/2007 11:03am
 Plotted By: vragajima

Xref
 impoly.

OFFICE	DATE	DESIGNED BY	DRAWN BY	CHECKED BY	APPROVED BY	DRAWING NUMBER
Pittsburgh, PA	11/22/07					121525-B18

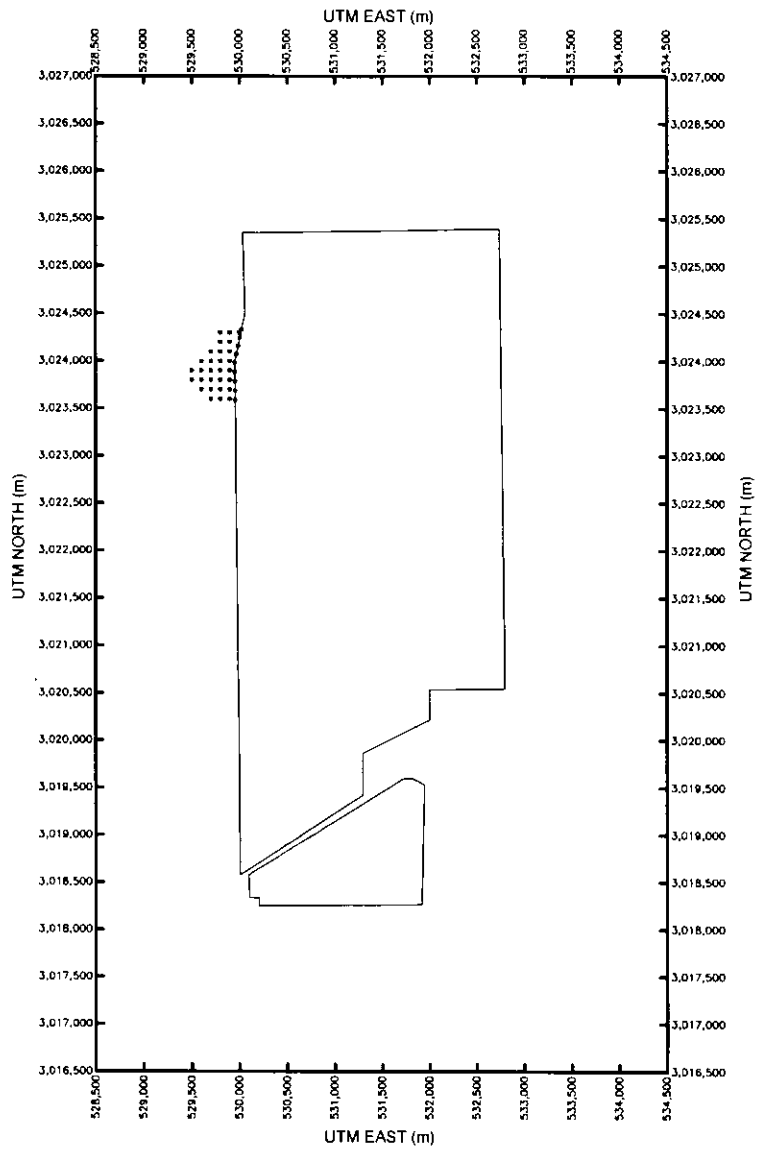

OKEECHOBEE LANDFILL, INC.
 OKEECHOBEE, FLORIDA

FIGURE 3-5A
 NO2 ANNUAL SIGNIFICANCE RECEPTORS
 BACK-UP BACT
 OKEECHOBEE LANDFILL, INC.
 OKEECHOBEE, FLORIDA

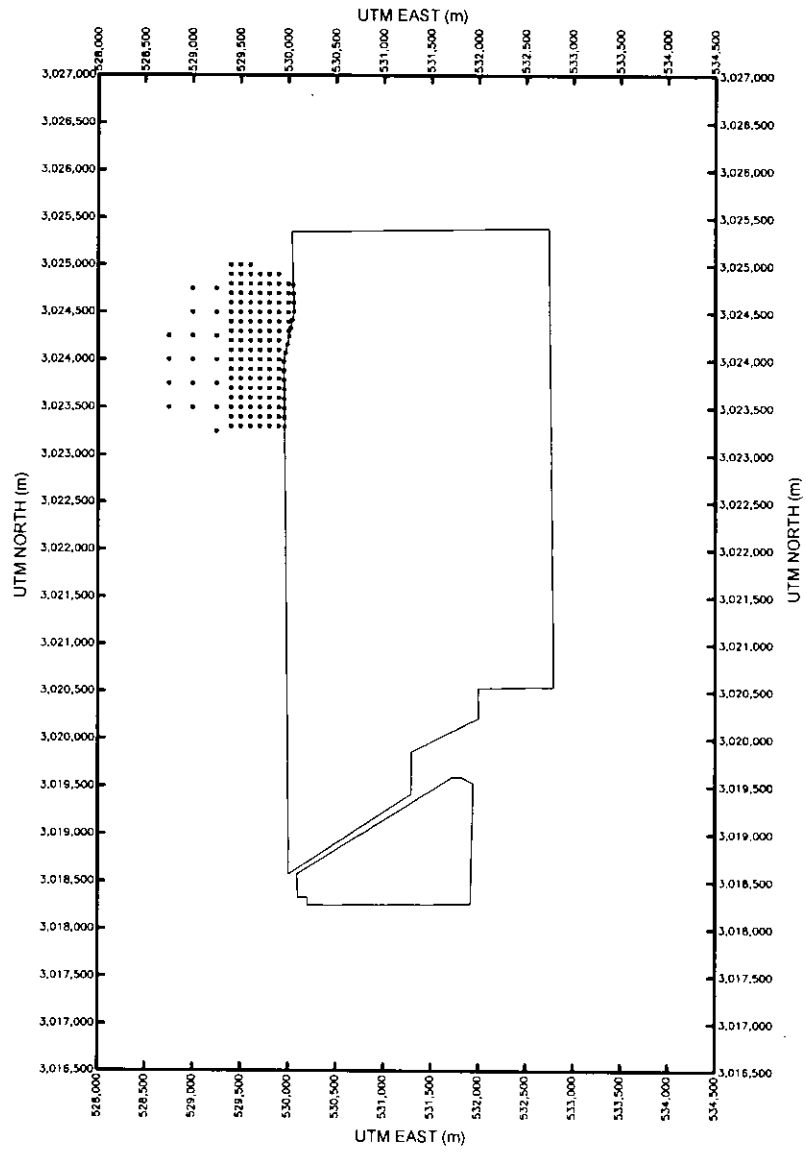

 Shaw Shaw Environmental, Inc.
OKEECHOBEE LANDFILL, INC. OKEECHOBEE, FLORIDA
FIGURE 3-5B SO2 ANNUAL SIGNIFICANCE RECEPTORS BACK-UP BACT OKEECHOBEE LANDFILL, INC. OKEECHOBEE, FLORIDA

OFFICE	DATE	DESIGNED BY	DRAWN BY	CHECKED BY	APPROVED BY	DRAWING NUMBER
Pittsburgh, PA	-/-/--	--	--	--	--	121525-B16

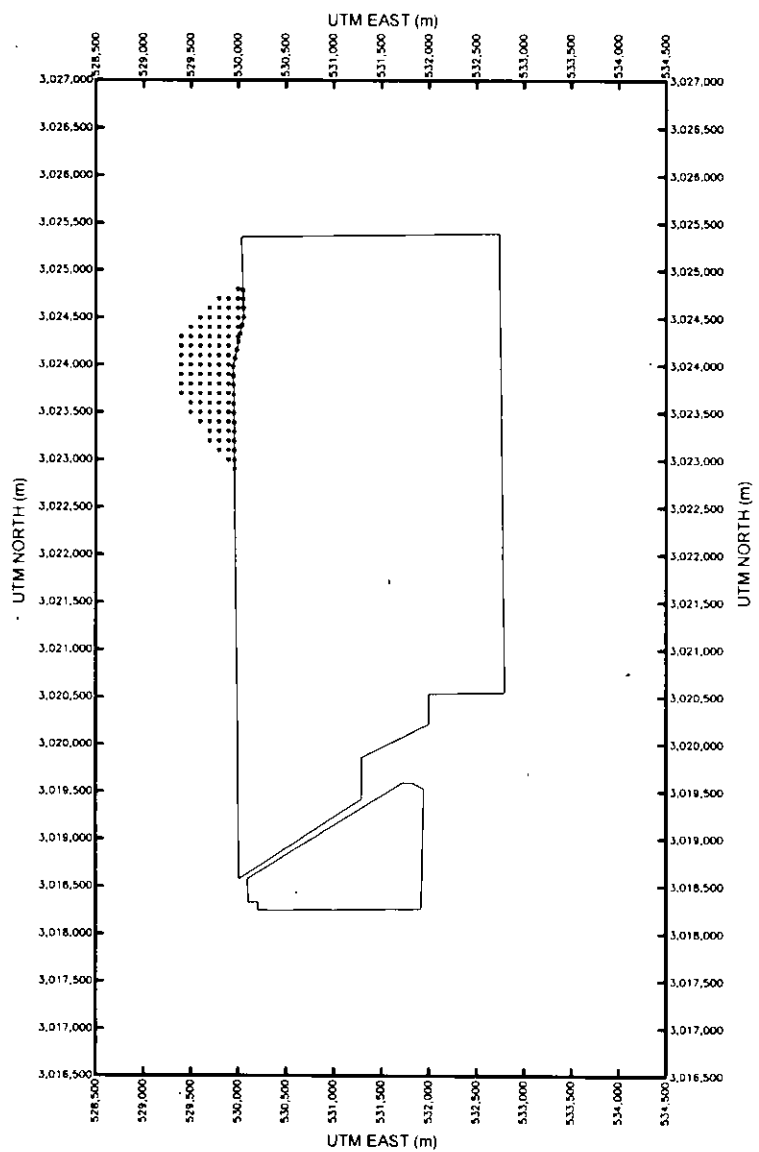

 Shaw Shaw Environmental, Inc.
OKEECHOBEE LANDFILL, INC. OKEECHOBEE, FLORIDA
FIGURE 3-5C SO2 3-HR. SIGNIFICANCE RECEPTORS BACK-UP BACT OKEECHOBEE LANDFILL, INC. OKEECHOBEE, FLORIDA

OFFICE	DATE	DESIGNED BY	DRAWN BY	CHECKED BY	APPROVED BY	DRAWING NUMBER
Pittsburgh, PA	1/1/07					121525-B15

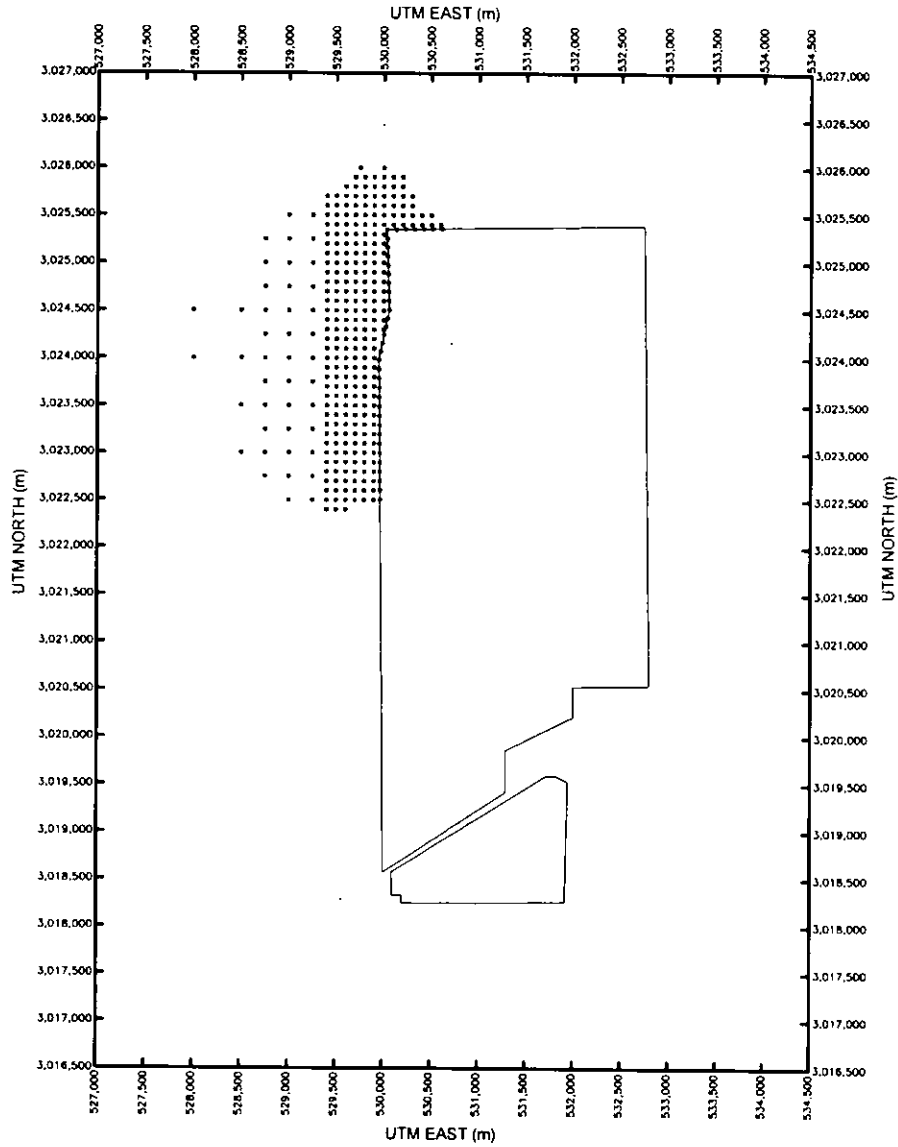

 Shaw Shaw Environmental, Inc.
OKEECHOBEE LANDFILL, INC. OKEECHOBEE, FLORIDA
FIGURE 3-5D SO2 24-HR. SIGNIFICANCE RECEPTORS BACK-UP BACT OKEECHOBEE LANDFILL, INC. OKEECHOBEE, FLORIDA

Appendix A

Emissions Calculations
Okeechobee (Berman Road) Landfill
Okeechobee, FL

BASELINE ACTUAL EMISSIONS														
EU NO.	Description	Average 24-month flow rate (scfm)	24-month period Hours of Operation	Units	Emissions									
					NO _x	CO	SO ₂ w/o BACT ^(c)	SO ₂ w/ BACT ^(c)	PM ₁₀	NMOC	VOC	HAP (Total)	HAP (Single)	H2S
003	Enclosed Flare Unit 1	2,237	16,902	lb/hr	3.66	12.2	131.6	Not relevant	1.0	0.4	0.1	0.6	0.5	1.4
				tpy	15.5	51.5	556.3		4.0	1.5	0.6	2.6	2.3	5.9
005	Enclosed Flare Unit 2	2,246	17,168	lb/hr	3.67	12.25	129.56		0.96	0.36	0.14	0.62	0.54	1.40
				tpy	15.8	52.6	556.1		4.1	1.6	0.6	2.6	2.3	6.0
004	Open Flare (Backup)	2,240	847	lb/hr	4.57	24.87	131.89		1.06	0.37	0.15	0.61	0.54	0.08
				tpy	1.0	5.3	27.9		0.2	0.1	0.0	0.1	0.1	0.0
NA	Open Flare (Odor Control)	764	5,150	lb/hr	1.6	8.5	45.0		0.4	0.1	0.1	0.2	0.2	0.03
				tpy	2.0	10.9	57.9		0.5	0.2	0.1	0.3	0.2	0.0
CURRENT ACTUAL BASELINE EMISSIONS		7,487		lb/hr	13.5	57.9	438.1		3.4	1.3	0.5	2.1	1.9	3.0
				tpy	34.3	120.4	1,198.2		8.9	3.4	1.4	5.7	5.0	12.0

SUMMARY - PROPOSED POTENTIAL TO EMIT WITHOUT BACT [INTERIM OPERATING SCENARIO]

Control Device ID	Description	Max. Potential LFG Flow (scfm)	Max. Annual Potential Operation (hours)	Units	Emissions										
					NO _x	CO	SO ₂ w/o BACT ^(c)	SO ₂ w/ BACT ^(c)	PM ₁₀	NMOC	VOC	HAP (Total)	HAP (Single)	H2S	
CD-01	Existing Enclosed Flare w/EVAP ^(a,b)	3,000	8760	lb/hr	5.4	18.0	176.2	Not relevant	1.4	0.5	0.19	0.8	0.7	1.87	
				tpy	23.7	78.8	771.6		6.2	2.1	0.8	3.6	3.2	8.2	
CD-02	Existing Enclosed Flare w/EVAP	3,000	8760	lb/hr	5.4	18.0	176.2		1.4	0.5	0.2	0.8	0.7	1.9	
				tpy	23.7	78.8	771.6		6.2	2.1	0.8	3.6	3.2	8.2	
CD-03	Open Unenclosed Flare (Backup)	0	0	lb/hr	0	0	0		0	0	0	0	0	0	0
				tpy	0	0	0		0	0	0	0	0	0	0.0
CD-04	Proposed Utility Flare (odor control)	3,300	8760	lb/hr	6.7	36.6	193.8		1.55	0.53	0.21	0.9	0.80	2.06	
				tpy	29.5	160.4	848.7		6.8	2.3	0.9	4.0	3.5	9.0	
CD-05	Proposed Utility Flare	3,300	8760	lb/hr	6.7	36.6	193.8		1.5	0.5	0.2	0.9	0.8	2.06	
				tpy	29.5	160.4	848.7		6.8	2.3	0.9	4.0	3.5	9.0	
CD-06	Proposed Utility Flare	3,300	8760	lb/hr	6.7	36.6	193.8		1.5	0.5	0.2	0.9	0.8	2.06	
				tpy	29.5	160.4	848.7		6.8	2.3	0.9	4.0	3.5	9.0	
TOTAL Proposed PTE without BACT				lb/hr	31.0	145.9	933.7		7.5	2.6	1.1	4.4	3.9	10.0	
				tpy	135.8	639.0	4,089.4		32.7	11.3	4.5	19.2	16.9	43.4	

Emissions Calculations
Okeechobee (Berman Road) Landfill
Okeechobee, FI

SUMMARY - PROPOSED POTENTIAL TO EMIT FOR TURBINE OPERATING CONDITIONS WITH BACT

Control Device ID	Description	Max. Potential LFG Flow (scfm)	Max. Annual Potential Operation	units	Emissions									
					NO _x	CO	SO ₂ w/o BACT ^(c)	SO ₂ w/ BACT ^(c)	PM ₁₀	NMOC	VOC	HAP (Total)	HAP (Single)	H2S
CD-11	Turbine ^(a,b)	4,000	8760	lb/hr	31.07	31.3	234.9	16.2	2.2	0.6	0.3	1.0	2.5	2.49
				tpy	136	137	1,029	71	10	3	1	4	11	10.92
CD-12	Turbine ^(a,b)	4,000	8760	lb/hr	31.07	31.3	234.9	16.2	2.2	0.6	0.3	1.0	2.5	2.49
				tpy	136	137	1,029	71	10	3	1	4	11	10.92
CD-13	Turbine ^(a,b)	4,000	8760	lb/hr	31.07	31.3	234.9	16.2	2.2	0.6	0.3	1.0	2.5	2.49
				tpy	136	137	1,029	71	10	3	1	4	11	10.92
CD-14	Turbine ^(a,b)	4,000	8760	lb/hr	31.07	31.3	234.9	16.2	2.2	0.6	0.3	1.0	2.5	2.49
				tpy	136	137	1,029	71	10	3	1	4	11	10.92
CD-15	Turbine ^(a,b)	4,000	8760	lb/hr	31.07	31.3	234.9	16.2	2.2	0.6	0.3	1.0	2.5	2.49
				tpy	136	137	1,029	71	10	3	1	4	11	10.92
CD-16	Turbine ^(a,b)	4,000	8760	lb/hr	31.07	31.3	234.9	16.2	2.2	0.6	0.3	1.0	2.5	2.49
				tpy	136	137	1,029	71	10	3	1	4	11	10.92
CD-17	Turbine ^(a,b)	4,000	8760	lb/hr	31.07	31.3	234.9	16.2	2.2	0.6	0.3	1.0	2.5	2.49
				tpy	136	137	1,029	71	10	3	1	4	11	10.92
CD-03	Open Unenclosed Flare	3,300	8760	lb/hr	6.7	36.6	193.8	13.36	1.5	0.5	0.2	0.9	0.8	2.06
				tpy	29	160	849	59	7	2	1	4	4	9.01
CD-04	Open Unenclosed Flare	1,100	8760	lb/hr	2.2	12.2	64.6	4.5	0.5	0.2	0.1	0.3	0.3	0.89
				tpy	10	53	283	20	2	1	0	1	1	3.00
TOTAL Proposed PTE with BACT		32,400		lb/hr	226.5	267.8	1,902.6	131.3	17.6	5.3	2.1	8.0	18.6	20.2
				tpy	991.9	1,173.0	8,333.0	574.8	76.8	23.0	9.0	35.0	81.1	88.5

Emissions Calculations
Okeechobee (Berman Road) Landfill
Okeechobee, FL

SUMMARY OF ALTERNATIVE OPERATING SCENARIO - POTENTIAL TO EMIT FOR PROPOSED FLARING														
Control Device ID	Description	Max. Potential LFG Flow (scfm)	Max. Annual Potential Operation (hours)	Units	Emissions									
					NO _x	CO	SO ₂ w/o BACT ^(c)	SO ₂ w/ BACT	PM ₁₀	NMOC	VOC	HAP (Total)	HAP (Single)	H2S
CD-01	Existing Enclosed Flare w/EVAP ^(a,b)	3,000	8760	lb/hr	5.4	18.0	176.2	12.1	1.4	0.5	0.2	0.8	0.7	1.9
				tpy	23.7	78.8	772	53.2	6.2	2.1	0.8	3.6	3.2	8.2
CD-02	Existing Enclosed Flare w/EVAP	3,000	8760	lb/hr	5.4	18.0	176.2	12.1	1.4	0.5	0.2	0.8	0.7	1.9
				tpy	23.7	78.8	772	53.2	6.2	2.1	0.8	3.6	3.2	8.2
CD-03	Open Unenclosed Flare (Backup)	3,300	8760	lb/hr	6.7	36.6	193.8	13.4	1.5	0.5	0.2	0.9	0.8	2.1
				tpy	29.5	160.4	848.7	58.5	6.8	2.3	0.9	4.0	3.5	4.0
CD-04	Proposed Utility Flare (odor control)	3,300	8760	lb/hr	6.7	36.6	193.8	13.4	1.5	0.5	0.2	0.9	0.8	2.06
				tpy	29.5	160.4	849	58.5	6.8	2.3	0.9	4.0	3.5	9.0
CD-05	Proposed Utility Flare	3,300	8760	lb/hr	6.7	36.6	193.8	13.4	1.5	0.5	0.2	0.9	0.8	2.06
				tpy	29.5	160.4	849	58.5	6.8	2.3	0.9	4.0	3.5	9.0
CD-06	Proposed Utility Flare	3,300	8760	lb/hr	6.7	36.6	193.8	13.4	1.5	0.5	0.2	0.9	0.8	2.06
				tpy	29.5	160.4	849	58.5	6.8	2.3	0.9	4.0	3.5	9.0
CD-07	Proposed Utility Flare	3,300	8760	lb/hr	6.7	36.6	193.8	13.4	1.5	0.5	0.2	0.9	0.8	2.06
				tpy	29.5	160.4	849	58.5	6.8	2.3	0.9	4.0	3.5	9.0
CD-08	Proposed Utility Flare	3,300	8760	lb/hr	6.7	36.6	193.8	13.4	1.5	0.5	0.2	0.9	0.8	2.06
				tpy	29.5	160.4	848.7	58.5	6.8	2.3	0.9	4.0	3.5	9.0
CD-09	Proposed Utility Flare	3,300	8760	lb/hr	6.7	36.6	193.8	13.4	1.5	0.5	0.2	0.9	0.8	2.06
				tpy	29.5	160.4	849	58.5	6.8	2.3	0.9	4.0	3.5	9.0
CD-10	Proposed Utility Flare	3,300	8760	lb/hr	6.7	36.6	193.8	13.4	1.5	0.5	0.2	0.9	0.8	2.1
				tpy	29.5	160.4	848.7	58.5	6.8	2.3	0.9	4.0	3.5	9.0
Total Proposed PTE Flaring with BACT				lb/hr	64.7	329.1	1,902.6	131.3	15.3	5.3	2.1	8.9	7.9	19.1
				tpy	283.2	1,441.2	8,333.0	574.8	66.6	23.0	9.0	39.0	34.4	83.4

Emissions Calculations
 Okeechobee (Berman Road) Landfill
 Okeechobee, FL

MAXIMUM POTENTIAL-TO-EMIT TO BASELINE ACTUAL NET INCREASE (highest rate used per pollutant)														
Control Device ID	Description	Max. Potential LFG Flow (scfm)	Max. Annual Potential Operation (hours)	Units	Emissions									
					NO _x	CO	SO ₂ w/o BACT	SO ₂ w/ BACT	PM ₁₀	NMOC	VOC	HAP (Total)	HAP (Single)	H2S
Varies	Control Device with For each pollutant, the	32,400	8760	tpy	957.6	1,320.8	1,320.8	(623.4)	67.9	19.6	7.6	33.3	29.4	71.4
Significant Emission Rates [62-210.200(264) F.A.C.]				tpy	40	100	40	40	15	50	40	NA	NA	10

Solar Turbines

A Caterpillar Company

PREDICTED ENGINE PERFORMANCE

Customer Waste Management		Model MARS 100-15000
Date 24-Oct-06		Process Type GSC
Prepared By Donald C Lyons		Match 59F MATCH
Engine Performance Code REV. 3.00		Gas GAS
Engine Performance Code REV. 3.0		Gas Type CHOICE NATURAL GAS

DATA FOR NOMINAL PERFORMANCE

Elevation	feet	50		
Inlet Loss	in H2O	3.6		
Exhaust Loss	in H2O	3.6		
		1	2	3
Engine Inlet Temperature	deg F	59.0	59.0	59.0
Relative Humidity	%	60.0	60.0	60.0
Specified Load*	kW	FULL	75.0%	50.0%
Net Output Power*	kW	10924	8193	5382
Fuel Flow	mmBtu/hr	111.28	80.11	68.99
Heat Rate*	Btu/kWh	10461	10585	12630
Therm Eff*	%	32.619	31.023	27.015
Engine Exhaust Flow	lbm/hr	342594	306920	263057
Exhaust Temperature	deg F	894	818	778

Fuel Gas Composition (Volume Percent)	Methane (CH ₄)	60.00
	Carbon Dioxide (CO ₂)	50.00
	Sulfur Dioxide (SO ₂)	0.0001

Fuel Gas Properties	LHV (Btu/Scf)	254.7	Specific Gravity	1.0266	Wobbe Index at 50F	446.6
---------------------	---------------	-------	------------------	--------	--------------------	-------

*Electric power measured at the generator terminals.

Notes	
Florida	

EMISSIONS DATA PROVIDED BY MANUFACTURER VIA EMAIL

-----Original Message-----

From: Chris D. Lyons [mailto:Lyons_Chris_D@solar-turbines.com]

Sent: Tuesday, October 24, 2006 11:52 AM

To: Unger, Dave (Renewable Energy)

Subject: Mars 100 emissions

Dave,

I need to get an official engineering response to your request. The landfill in Paris had a different fuel composition than your site in Florida. I am assuming 50% methane, 50% carbon dioxide.

I have attached the expected performance and below are what I believe will be the emissions.

Full	load			
NOx	=	60 ppmv @15%oxygen	=	31.067 lb/hr
CO	=	60 ppmv @15%oxygen	=	31.517 lb/hr
	75% Load			
NOx	=	42 ppmv @15%oxygen	=	16.782 lb/hr
CO	=	80 ppmv @15%oxygen	=	19.457 lb/hr
	50% Load			
NOx	=	30 ppmv @15%oxygen	=	10.278 lb/hr
CO	=	150 ppmv @15%oxygen	=	31.279 lb/hr

Let me know if you will need any other data. It will take a few days to receive an official response back from engineering.

Regards,

Chris Lyons

Solar Turbines

Phone: 1-858-694-6586

Parameter	Value	Units	Reference
Exhaust Temp	894	F	Mars 100-15000, 100% Load
Exhaust Temp	818	F	Mars 100-15000, 75% Load
Exhaust Temp	778	F	Mars 100-15000, 50% Load
Stack Height	50	ft	Bruce Maillet
Stack Side	87.5	in	Solar Turbines
Stack Side	90.5625	in	Solar Turbines
Stack Interior Diameter	100	in	Calculated
PM10 Rate	0.023	lb/MMBtu	AP-42, Table 3.1-2b
Turbine Inlet	4000	scfm	Solar Turbines
Lanfill gas HHV	400	Btu/scf	AP-42, Table 3.1-2b
PM10 Rate	2.2	lb/hr	Calculated

Calculation of Flow Rate

		100%	75%	50%
Total Mass Out	lb/hr	342,595	306,920	263,057
Solar Turbines Inc. Mass out	lb/hr	354239		
Solar Turbines Inc. Exhaust Flow	acfm	200336		
Total Flow out	acfm	193,751		148,769
Total Flow out	ft/s	58.68	52.57	45.06

~~354,239~~
~~40,488~~
 Solar Turbine Cals

Availability 51 weeks/yr 98%

Emissions Calculations
Okeechobee (Berman Road) Landfill
Okeechobee, FL

Criteria Pollutant Emissions - Turbines

Operation Period 8,760 hr
 LFG inlet flow, standard 4,000 scfm
 Heat Input 90 MMBtu/hr
 Standard Temperature^a 60 °F
 520 °R

SO₂ Emission Rate		
SO ₂ concentration in exhaust gas	400.05 ppmv	
SO ₂ emission rate	16.20 lb/hr	71.0 tpy

LFG Compound	CAS	MW (lb/lb-mol)	Conc (ppmv) ^a	Control Eff ^{a,b}	Individual Compound Contribution to SO ₂		
					No. of S Atoms	S Conc (ppmv)	SO ₂ Emiss (lb/hr)
Carbon Disulfide	75-15-0	76.13	0.58	100.0%	2	1.17	0.05
Carbonyl Sulfide	463-58-1	80.07	0.49	100.0%	1	0.49	0.02
Dimethyl Sulfide (methyl sulfide)	75-18-3	62.13	7.82	100.0%	1	7.82	0.32
Ethyl Mercaptan (ethanethiol)	75-08-1	62.13	2.28	100.0%	1	2.28	0.09
Hydrogen Sulfide	7783-06-4	34.08	385.80	100.0%	1	385.8	15.62
Methyl Mercaptan	74-93-1	48.11	2.49	100%	1	2.49	0.10
Total Contribution to SO ₂ :						400.05	16.20

NMOC Emission Rate			
NMOC conc inlet gas ^a	595	ppmv	
MW hexane	86.18	lb/lb-mol	
destruction efficiency	98%		
mass NMOC inlet gas	32.4	lb/hr	
NMOC emission rate	0.65	lb/hr	2.84 tpy
VOC Emission Rate			
NMOC conc inlet gas ^a	595	ppmv	
VOC fraction of NMOC ^a	39%		
VOC concentration in inlet gas	232	ppmv	
MW hexane	86.18	lb/lb-mol	
mass VOC inlet gas	12.6	lb/hr	
destruction efficiency	98%		
VOC emission rate	0.25	lb/hr	1.11 tpy

^aU.S. E.P.A., *Compilation of Air Pollutant Emission Factors, Volume 1. Stationary Point and Area Sources ("AP-42"), 5th Ed.*, November 1998.
^bAP-42 gives ranges for control efficiencies. Control efficiencies for halogenated species range from 91 to 99.7 percent. The upper end of the range is used here resulting in maximum calculated emissions of SO₂.
^cLFG Specialties Inc. (typical)

Emissions Calculations
Okeechobee (Berman Road) Landfill
Okeechobee, FL

LFG inlet flow 4,000 scfm
Proposed LFG Turbines

LFG Compound	HAP	CAS	MW (lb/lb-mol)	Compound Conc & Mass in Inlet Gas		Control Eff ^{a,b}	turbine Exhaust	
				(ppmv) ^a	(lb/hr)		(lb/hr) ^c	(tpy) ^c
1,1,1 - Trichloroethane (methyl chloroform)	x	71-55-6	133.41	0.48	4.05E-02	98.0%	8.10E-04	3.55E-03
1,1,2,2 - Tetrachloroethane	x	79-34-5	167.85	1.11	1.18E-01	98.0%	2.36E-03	1.03E-02
1,1,2 - Trichloroethane (1,1,2 TCA)	x	79-00-5	133.41	0.10	8.43E-03	98.0%	1.69E-04	7.39E-04
1,1 - Dichloroethane (ethylidene dichloride)	x	75-34-3	98.96	2.35	1.47E-01	98.0%	2.94E-03	1.29E-02
1,1 - Dichloroethene (vinylidene chloride)	x	75-35-4	96.94	0.20	1.23E-02	98.0%	2.46E-04	1.08E-03
1,2 - Dichloroethane (ethylene dichloride)	x	107-06-2	98.96	0.41	2.55E-02	98.0%	5.09E-04	2.23E-03
1,2 - Dichloropropane (propylene dichloride)	x	78-87-5	112.99	0.18	1.29E-02	98.0%	2.57E-04	1.13E-03
2-Propanol (isopropyl alcohol)	--	67-63-0	60.11	50.1	1.90E+00	98.0%	3.81E-02	1.67E-01
Acetone (2-propanone)	--	67-64-1	58.08	7.01	2.57E-01	98.0%	5.15E-03	2.25E-02
Acrylonitrile (Propenenitrile)	x	107-13-1	53.06	6.33	2.12E-01	98.0%	4.25E-03	1.86E-02
Benzene	x	71-43-2	78.12	1.91	9.43E-02	98.0%	1.89E-03	8.26E-03
Bromodichloromethane	--	75-27-4	163.83	3.13	3.24E-01	98.0%	6.48E-03	2.84E-02
Butane	--	106-97-8	58.12	5.03	1.85E-01	98.0%	3.70E-03	1.62E-02
Carbon Disulfide	x	75-15-0	76.14	0.58	2.81E-02	98.0%	5.61E-04	2.46E-03
Carbon Tetrachloride	x	56-23-5	153.84	0.004	3.89E-04	98.0%	7.78E-06	3.41E-05
Carbonyl Sulfide	x	463-58-1	60.07	0.49	1.86E-02	98.0%	3.72E-04	1.63E-03
Chlorobenzene (monochlorobenzene)	x	108-90-7	112.56	0.25	1.81E-02	98.0%	3.61E-04	1.58E-03
Chlorodifluoromethane (CFC-22, freon-22)	--	75-45-6	86.47	1.30	7.11E-02	98.0%	1.42E-03	6.22E-03
Chloroethane (ethyl chloride)	x	75-00-3	64.52	1.25	5.10E-02	98.0%	1.02E-03	4.47E-03
Chloroform (trichloromethane)	x	67-66-3	119.38	0.03	2.26E-03	98.0%	4.53E-05	1.98E-04
Chloromethane (methyl chloride)	x	74-87-3	50.49	1.21	3.86E-02	98.0%	7.72E-04	3.38E-03
1,4 Dichlorobenzene (p-dichlorobenzene)	x	106-46-7	147	0.21	1.98E-02	98.0%	3.96E-04	1.73E-03
Dichlorodifluoromethane (CFC-12, freon-12)	--	75-71-8	120.91	15.7	1.20E+00	98.0%	2.40E-02	1.05E-01
Dichlorofluoromethane (freon-21)	--	75-43-4	102.92	2.82	1.70E-01	98.0%	3.41E-03	1.49E-02
Dichloromethane (methylene chloride)	x	75-09-2	84.93	14.3	7.68E-01	98.0%	1.54E-02	6.72E-02
Dimethyl Sulfide (methyl sulfide)	--	75-18-3	62.13	7.82	3.07E-01	98.0%	6.14E-03	2.69E-02
Ethane	--	74-84-0	30.07	889	1.69E+01	98.0%	3.38E-01	1.48E+00
Ethanol (ethyl alcohol)	--	64-17-5	46.08	27.2	7.92E-01	98.0%	1.58E-02	6.94E-02
Ethylbenzene ^d	x	100-41-4	106.17	4.61	3.09E-01	98.0%	6.19E-03	2.71E-02
Ethyl Mercaptan (ethanethiol)	--	75-08-1	62.13	1.25	4.91E-02	98.0%	9.82E-04	4.30E-03
Ethylene dibromide (1,2 dibromoethane)	x	106-93-4	187.88	0.001	1.19E-04	98.0%	2.38E-06	1.04E-05
Fluorotrichloromethane (CFC-11, freon-11)	--	75-69-4	137.37	0.76	6.60E-02	98.0%	1.32E-03	5.78E-03
Hexane	x	110-54-3	86.18	6.57	3.58E-01	98.0%	7.16E-03	3.14E-02
Hydrogen Sulfide	--	7783-06-4	34.08	385.8	8.31E+00	98.0%	1.66E-01	7.28E-01
Mercury (total)	x	7439-97-6	200.61	2.92E-4	3.70E-05	0.0%	3.70E-05	1.62E-04
Methyl Ethyl Ketone (2-butanone)	--	78-93-3	72.11	7.09	3.23E-01	98.0%	6.46E-03	2.83E-02
Methyl Isobutyl Ketone (hexone)	x	108-10-1	100.16	1.87	1.18E-01	98.0%	2.37E-03	1.04E-02
Methyl Mercaptan	--	74-93-1	48.11	2.49	7.57E-02	98.0%	1.51E-03	6.63E-03
Pentane	--	109-66-0	72.15	3.29	1.50E-01	98.0%	3.00E-03	1.31E-02
ethene)	x	127-18-4	165.83	3.73	3.91E-01	98.0%	7.82E-03	3.42E-02
Propane	--	74-98-6	44.1	11.1	3.09E-01	98.0%	6.19E-03	2.71E-02
Toluene (methylbenzene)	x	108-88-3	92.14	39.3	2.29E+00	98.0%	4.58E-02	2.00E-01
Trichloroethylene (trichloroethene)	x	79-01-6	131.38	2.82	2.34E-01	98.0%	4.68E-03	2.05E-02
dichloroethylene)	--	156-60-5	96.94	2.84	1.74E-01	98.0%	3.48E-03	1.52E-02
Vinyl Chloride (chloroethylene, VCM)	x	75-01-4	62.50	7.34	2.90E-01	98.0%	5.80E-03	2.54E-02
Xylenes (m, o, p)	x	1330-20-7	106.17	12.1	8.12E-01	98.0%	1.62E-02	7.11E-02
Hydrogen Chloride	x	7647-01-0	36.50	42.0	9.69E-01	0.0%	9.69E-01	4.24E+00
Total HAP							1.10	4.8
Maximum Single HAP							0.97	4.24

^aU.S. E.P.A., *Compilation of Air Pollutant Emission Factors, Volume I. Stationary Point and Area Sources ("AP-42"), 5th Ed.*

^bAP-42 gives ranges for control efficiencies. Control efficiencies for halogenated species range from 91 to 99.7 percent and control. Control efficiencies for non-halogenated species range from 38 to 91 percent. For permitting purposes, the lower end

^cProduct of combustion

^dBecause HCl is a production of combustion, a default outlet concentration is listed; AP-42, Section 2.4.4.

Note: "x" denotes a HAP only or a HAP and VOC; "y" denotes a VOC only

**Emissions Calculations
Okeechobee (Berman Road) Landfill
Okeechobee, FL**

EU003 3,000-scfm enclosed flare w/evap

Standard Conditions, Constants, and Typical Values

Category	Value	Equivalent
Standard Temperature ^a	60 °F	520 °R
Universal Gas Constant	0.7302 atm-ft ³ /lb-mol ^o R	
Pressure ^a	1 atm	
Methane Heating Value ^b	1,000 Btu/ft ³	
LFG Methane Component ^c	50%	
LFG Typical Heating Value	500 Btu/ft ³	
LFG Temperature ^c	100 °F	560 °R
LFG Moisture ^c	8%	
Methane Combustion Constant ^d	9.53 ft ³ air/ft ³ CH ₄	

^aIndustrial STP (60°F, 30.00 in. Hg, 1 atm)

^bTypical

^cAssumed

^dProfessional Engineering Registration Program , 23-9.

Fuel & Equipment - Enclosed Flare

Flare Information	Value	Equivalent
Operation Period ^a	8,760 hr	
LFG inlet flow, standard ^b	3,000 scfm	
LFG Inlet Flow, dry standard	2,760 dscfm	
Heat Input	90 MMBtu/hr	
Design Flare Operating Temperature ^c	1,400 °F	1,860 °R
Excess Air for Combustion ^c	230%	
Flare Tip Flow, standard	50,174 scfm	
Flare Tip Flow, actual	179,467 acfm	
Flare Tip Diameter ^b	10.0 ft	
Flare Tip Exhaust Velocity	2,285 ft/min	38.1 ft/s
Flare Tip Height, above local grade ^b	45 ft	

^aPermit Applicant

^bFlare manufacturer - based on LFG model EF1045I12

^cFunction of design flame temperature; values are typical and are provided for 1400°F, 1600°F, 1800°F, and 2000°F by a flare manufacturer

Criteria Pollutant Emissions - Enclosed Flare
EU003 3,000-scfm enclosed flare w/evap
Operation Period 8,760 hr
LFG inlet flow, standard 3,000 scfm
Heat Input 90 MMBtu/hr

SO₂ Emission Rate without BACT							
SO ₂ concentration in exhaust gas		5800.25 ppmv					
SO ₂ emission rate		176.16 lb/hr		771.6 tpy			
LFG Compound	CAS	MW (lb/lb-mol)	Conc (ppmv) ^a	Control Eff ^{a,b}	Individual Compound Contribution to SO ₂		
					No. of S Atoms	S Conc (ppmv)	SO ₂ Emiss (lb/hr)
Carbon Disulfide	75-15-0	76.13	0.58	100.0%	2	1.17	0.04
Carbonyl Sulfide	463-58-1	60.07	0.49	100.0%	1	0.49	0.01
Dimethyl Sulfide (methyl sulfide)	75-18-3	62.13	7.82	100.0%	1	7.82	0.24
Ethyl Mercaptan (ethanethiol)	75-08-1	62.13	2.28	100.0%	1	2.28	0.07
Hydrogen Sulfide	7783-06-4	34.08	5786.00	100.0%	1	5786.0	175.72
Methyl Mercaptan	74-93-1	48.11	2.49	100.0%	1	2.49	0.08
Total Contribution to SO ₂ :						5800.25	176.16
SO₂ Emission Rate with BACT							
Sulfur concentration in exhaust gas		400.05 ppmv					
SO ₂ emission rate		12.15 lb/hr uncontrolled		53.2 tpy			
LFG Compound	CAS	MW (lb/lb-mol)	Conc (ppmv) ^a	Control Eff ^{a,b}	Individual Compound Contribution to SO ₂		
					No. of S Atoms	S Conc (ppmv)	SO ₂ Emiss (lb/hr)
Carbon Disulfide	75-15-0	76.13	0.58	100.0%	2	1.17	0.04
Carbonyl Sulfide	463-58-1	60.07	0.49	100.0%	1	0.49	0.01
Dimethyl Sulfide (methyl sulfide)	75-18-3	62.13	7.82	100.0%	1	7.82	0.24
Ethyl Mercaptan (ethanethiol)	75-08-1	62.13	2.28	100.0%	1	2.28	0.07
Hydrogen Sulfide	7783-06-4	34.08	385.80	100.0%	1	385.8	11.72
Methyl Mercaptan	74-93-1	48.11	2.49	100.0%	1	2.49	0.08
Total Contribution to SO ₂ :						400.05	12.15
PM₁₀ Emission Rate							
PM emission factor ^c	17 lb/MM dscf CH ₄						
PM emission rate	1.41 lb/hr	6.2 tpy					
NO₂ Emission Rate							
NO ₂ emission factor ^c	0.06 lb/MMBtu						
NO ₂ emission rate	5.4 lb/hr	23.7 tpy					
CO Emission Rate							
CO emission factor ^c	0.20 lb/MMBtu						
CO emission rate	18.0 lb/hr	79 tpy					
NMOC Emission Rate							
NMOC conc inlet gas ^a	595 ppmv						
MW hexane	86.18 lb/lb-mol						
destruction efficiency	98%						
mass NMOC inlet gas	24.3 lb/hr						
NMOC emission rate	0.49 lb/hr	2.13 tpy					
VOC Emission Rate							
NMOC conc inlet gas ^a	595 ppmv						
VOC fraction of NMOC ^a	39%						
VOC concentration in inlet gas	232 ppmv						
MW hexane	86.18 lb/lb-mol						
mass VOC inlet gas	9.5 lb/hr						
destruction efficiency	98%						
VOC emission rate	0.19 lb/hr	0.83 tpy					

^aU.S. E.P.A., *Compilation of Air Pollutant Emission Factors, Volume I. Stationary Point and Area Sources ("AP-42"), 5th Ed., November 1998.*

^bAP-42 gives ranges for control efficiencies. Control efficiencies for halogenated species range from 91 to 99.7 percent. The upper end of the range is used here resulting in maximum calculated emissions of SQ

^cLFG Specialties Inc. (typical)

Emissions Calculations
Okeechobee (Berman Road) Landfill
Okeechobee, FL

LFG inlet flow 3,000 scfm
EU003 3,000-scfm enclosed flare w/evap

LFG Compound	HAP	VOC	CAS	MW (lb/lb-mol)	Compound Conc & Mass in Inlet Gas		Control Eff ^{a,b}	Flare Exhaust	
					(ppmv) ^a	(lb/hr)		(lb/hr) ^c	(tpy) ^c
1,1,1 - Trichloroethane (methyl chloroform)	x	--	71-55-6	133.41	0.48	3.04E-02	98.0%	6.07E-04	2.66E-03
1,1,2,2 - Tetrachloroethane	x	x	79-34-5	167.85	1.11	8.83E-02	98.0%	1.77E-03	7.74E-03
1,1,2 - Trichloroethane (1,1,2 TCA)	x	x	79-00-5	133.41	0.10	6.32E-03	98.0%	1.26E-04	5.54E-04
1,1 - Dichloroethane (ethylidene dichloride)	x	x	75-34-3	98.96	2.35	1.10E-01	98.0%	2.20E-03	9.66E-03
1,1 - Dichloroethane (vinylidene chloride)	x	x	75-35-4	96.94	0.20	9.24E-03	98.0%	1.85E-04	8.09E-04
1,2 - Dichloroethane (ethylene dichloride)	x	x	107-06-2	98.96	0.41	1.91E-02	98.0%	3.82E-04	1.67E-03
1,2 - Dichloropropane (propylene dichloride)	x	x	78-87-5	112.99	0.18	9.64E-03	98.0%	1.93E-04	8.45E-04
2-Propanol (isopropyl alcohol)	--	x	67-63-0	60.11	50.1	1.43E+00	98.0%	2.86E-02	1.25E-01
Acetone (2-propanone)	--	--	67-64-1	58.08	7.01	1.93E-01	98.0%	3.86E-03	1.69E-02
Acrylonitrile (Propenenitrile)	x	x	107-13-1	53.06	6.33	1.59E-01	98.0%	3.18E-03	1.39E-02
Benzene	x	x	71-43-2	78.12	1.91	7.07E-02	98.0%	1.41E-03	6.20E-03
Bromodichloromethane	--	x	75-27-4	163.83	3.13	2.43E-01	98.0%	4.86E-03	2.13E-02
Butane	--	x	106-97-8	58.12	5.03	1.39E-01	98.0%	2.77E-03	1.21E-02
Carbon Disulfide	x	x	75-15-0	76.14	0.58	2.10E-02	98.0%	4.21E-04	1.84E-03
Carbon Tetrachloride	x	x	56-23-5	153.84	0.004	2.92E-04	98.0%	5.83E-06	2.56E-05
Carbonyl Sulfide	x	x	463-58-1	60.07	0.49	1.40E-02	98.0%	2.79E-04	1.22E-03
Chlorobenzene (monochlorobenzene)	x	x	108-90-7	112.56	0.25	1.36E-02	98.0%	2.71E-04	1.19E-03
Chlorodifluoromethane (CFC-22, freon-22)	--	--	75-45-6	86.47	1.30	5.33E-02	98.0%	1.07E-03	4.67E-03
Chloroethane (ethyl chloride)	x	x	75-00-3	64.52	1.25	3.82E-02	98.0%	7.65E-04	3.35E-03
Chloroform (trichloromethane)	x	x	67-66-3	119.38	0.03	1.70E-03	98.0%	3.40E-05	1.49E-04
Chloromethane (methyl chloride)	x	x	74-87-3	50.49	1.21	2.90E-02	98.0%	5.79E-04	2.54E-03
1,4 Dichlorobenzene (p-dichlorobenzene)	x	x	106-46-7	147	0.21	1.48E-02	98.0%	2.97E-04	1.30E-03
Dichlorodifluoromethane (CFC-12, freon-12)	--	--	75-71-8	120.91	15.7	9.00E-01	98.0%	1.80E-02	7.88E-02
Dichlorofluoromethane (freon-21)	--	--	75-43-4	102.92	2.62	1.28E-01	98.0%	2.56E-03	1.12E-02
Dichloromethane (methylene chloride)	x	--	75-09-2	84.93	14.3	5.76E-01	98.0%	1.15E-02	5.04E-02
Dimethyl Sulfide (methyl sulfide)	--	x	75-18-3	62.13	7.82	2.30E-01	98.0%	4.61E-03	2.02E-02
Ethane	--	--	74-84-0	30.07	889	1.27E+01	98.0%	2.53E-01	1.11E+00
Ethanol (ethyl alcohol)	--	x	64-17-5	46.08	27.2	5.94E-01	98.0%	1.19E-02	5.20E-02
Ethylbenzene ^d	x	x	100-41-4	106.17	4.61	2.32E-01	98.0%	4.64E-03	2.03E-02
Ethyl Mercaptan (ethanethiol)	--	x	75-08-1	62.13	1.25	3.68E-02	98.0%	7.36E-04	3.23E-03
Ethylene dibromide (1,2 dibromoethane)	x	x	106-93-4	187.88	0.001	8.91E-05	98.0%	1.78E-06	7.80E-06
Fluorotrichloromethane (CFC-11, freon-11)	--	--	75-69-4	137.37	0.76	4.95E-02	98.0%	9.90E-04	4.34E-03
Hexane	x	x	110-54-3	86.18	6.57	2.68E-01	98.0%	5.37E-03	2.35E-02
Hydrogen Sulfide	--	--	7783-06-4	34.08	385.8	6.23E+00	98.0%	1.25E-01	5.46E-01
Mercury (total)	x	--	7439-97-6	200.61	2.92E-4	2.78E-05	0.0%	2.78E-05	1.22E-04
Methyl Ethyl Ketone (2-butanone)	--	--	78-93-3	72.11	7.09	2.42E-01	98.0%	4.85E-03	2.12E-02
Methyl Isobutyl Ketone (hexone)	x	x	108-10-1	100.16	1.87	8.88E-02	98.0%	1.78E-03	7.78E-03
Methyl Mercaptan	--	x	74-93-1	48.11	2.49	5.68E-02	98.0%	1.14E-03	4.97E-03
Pentane	--	x	109-66-0	72.15	3.29	1.13E-01	98.0%	2.25E-03	9.86E-03
ethene)	x	x	127-18-4	165.83	3.73	2.93E-01	98.0%	5.86E-03	2.57E-02
Propane	--	x	74-98-6	44.1	11.1	2.32E-01	98.0%	4.64E-03	2.03E-02
Toluene (methylbenzene)	x	x	108-88-3	92.14	39.3	1.72E+00	98.0%	3.43E-02	1.50E-01
Trichloroethylene (trichloroethene)	x	x	79-01-6	131.38	2.82	1.76E-01	98.0%	3.51E-03	1.54E-02
dichloroethylene)	--	--	156-60-5	96.94	2.84	1.31E-01	98.0%	2.61E-03	1.14E-02
Vinyl Chloride (chloroethylene, VCM)	x	x	75-01-4	62.50	7.34	2.17E-01	98.0%	4.35E-03	1.91E-02
Xylenes (m, o, p)	x	x	1330-20-7	106.17	12.1	6.09E-01	98.0%	1.22E-02	5.33E-02
Hydrogen Chloride	x	--	7647-01-0	36.50	42.0	7.27E-01	0.0%	7.27E-01	3.18E+00
Total HAP ^a								0.82	3.6
Maximum Single HAP								0.73	3.18
Hydrogen Sulfide without BACT				34.08	5785.0	9.35E+01	98.0%	1.87	8.19

^aU.S. E.P.A., *Compilation of Air Pollutant Emission Factors, Volume I. Stationary Point and Area Sources ("AP-42")*, 5th Ed., November 1998. Tables 2.4-1, 2.4-2, 2.4-3.

^bAP-42 gives ranges for control efficiencies. Control efficiencies for halogenated species range from 91 to 99.7 percent and control. Control efficiencies for non-halogenated species range from 38 to 91 percent. For permitting purposes, the lower end of each ranges is used here.

^cProduct of combustion

^dBecause HCl is a production of combustion, a default outlet concentration is listed; AP-42, Section 2.4.4.

Note: "x" denotes a HAP only or a HAP and VOC; "y" denotes a VOC only

**Emissions Calculations
Okeechobee (Berman Road) Landfill
Okeechobee, FL**

EU NEW - Proposed 3,000-scfm utility flare

Standard Conditions, Constants, and Typical Values

Category	Value	Equivalent
Standard Temperature ^a	60 °F	520 °R
Universal Gas Constant	0.7302	atm-ft ³ /lb-mol°R
Pressure ^a	1	atm
Methane Heating Value ^b	1,000	Btu/ft ³
LFG Methane Component ^c	50%	%
LFG Typical Heating Value	500	Btu/ft ³
LFG Temperature ^c	100 °F	560 °R
LFG Moisture ^c	8%	%

^aIndustrial STP (60°F, 30.00 in. Hg, 1 atm)

^bTypical

^cAssumed

Fuel & Equipment - Open Flare

Flare Information	Value	Equivalent
No. of Hours of Operation Per Day ^a	24	hr
No. of Days in Averaging Period ^a	365	day
Operation Period ^a	8,760	hr
LFG inlet flow, standard ^a	3,300	scfm
LFG Inlet Flow, dry standard	3,036	dscfm
Heat Input	99.0	MMBtu/hr
Design Flare Operating Temperature ^b	1,400	°F
Flare Tip Flow, standard	3,300	scfm
Flare Tip Flow, actual	3,554	acfm
Flare Tip Diameter ^b	1.17	ft
Flare Tip Exhaust Velocity	3,324	ft/min
Flare Tip Height, above local grade ^b	35	ft

^aPermit Applicant

Criteria Pollutant Emissions - Open Flare

Operation Period	8,760	hr
LFG inlet flow, standard	3,300	scfm
Heat Input	99.0	MMBtu/hr

SO₂ Emission Rate		
SO ₂ concentration in exhaust gas	5800.25	ppmv
SO ₂ emission rate	193.77	lb/hr
	848.73	ton/yr

LFG Compound	CAS	MW (lb/lb-mol)	Conc (ppmv) ^a	Control Eff ^{a,b}	Individual Compound Contribution to SO ₂		
					No. of S Atoms	S Conc (ppmv)	SO ₂ Emiss (lb/hr)
Carbon Disulfide	75-15-0	76.13	0.58	100.0%	2	1.17	0.04
Carbonyl Sulfide	463-58-1	60.07	0.49	100.0%	1	0.49	0.02
Dimethyl Sulfide (methyl sulfide)	75-18-3	62.13	7.82	100.0%	1	7.82	0.26
Ethyl Mercaptan (ethanethiol)	75-06-1	62.13	2.28	100.0%	1	2.28	0.08
Hydrogen Sulfide	7783-06-4	34.06	5786.00	100.0%	1	5786.0	193.30
Methyl Mercaptan	74-93-1	48.11	2.49	100.0%	1	2.49	0.08
Total Contribution to SO ₂ :						5800.25	193.77

SO₂ Emission Rate with BACT

SO ₂ concentration in exhaust gas	400.05	ppmv
SO ₂ emission rate	13.36	lb/hr
	58.54	tpy

LFG Compound	CAS	MW (lb/lb-mol)	Conc (ppmv) ^a	Control Eff ^{a,b}	Individual Compound Contribution to SO ₂		
					No. of S Atoms	S Conc (ppmv)	SO ₂ Emiss (lb/hr)
Carbon Disulfide	75-15-0	76.13	0.58	100.0%	2	1.17	0.04
Carbonyl Sulfide	463-58-1	60.07	0.49	100.0%	1	0.49	0.02
Dimethyl Sulfide (methyl sulfide)	75-18-3	62.13	7.82	100.0%	1	7.82	0.26
Ethyl Mercaptan (ethanethiol)	75-06-1	62.13	2.28	100.0%	1	2.28	0.08
Hydrogen Sulfide	7783-06-4	34.06	385.80	100.0%	1	385.8	12.89
Methyl Mercaptan	74-93-1	48.11	2.49	100.0%	1	2.49	0.08
Total Contribution to SO ₂ :						400.05	13.36

PM₁₀ Emission Rate

PM emission factor ^a	17	lb/MM dscf CH ₄
PM emission rate	1.55	lb/hr
	6.78	tpy

NO₂ Emission Rate

NO ₂ emission factor ^c	0.068	lb/MMBtu
NO ₂ emission rate	8.73	lb/hr
	29.49	tpy

CO Emission Rate

CO emission factor ^d	0.37	lb/MMBtu
CO emission rate	36.6	lb/hr
	160.4	tpy

NMOC Emission Rate

NMOC conc inlet gas ^a	595	ppmv
MW hexane	86.18	lb/lb-mol
destruction efficiency	98%	
mass NMOC inlet gas	26.74	lb/hr
NMOC emission rate	0.53	lb/hr
	2.34	tpy

VOC Emission Rate

NMOC conc inlet gas ^a	595	ppmv
VOC fraction of NMOC ^a	39%	
VOC concentration in inlet gas	232	ppmv
MW hexane	86.18	lb/lb-mol
mass VOC inlet gas	10.43	lb/hr
destruction efficiency	98%	
VOC emission rate	0.21	lb/hr
	0.91	tpy

^aEPA 1998, "Compilation of Air Pollutant Emission Factors, Volume I. Stationary Point and Area Sources" (AP-42), 5th Ed., November

^bAP-42 gives ranges for control efficiencies. Control efficiencies for halogenated species range from 91 to 99.7 percent. The upper end of the range is used here resulting in maximum calculated emissions of SO₂

^cLFG Specialties Inc. (typ:cal)

**Emissions Calculations
Okeechobee (Berman Road) Landfill
Okeechobee, FL**

Air Toxics Emissions from Open Flare *The flare's inlet 3,300 scfm*

LFG Compound	HAP	CAS	MW (lb/lb-mol)	Compound Conc & Mass in Inlet Gas		Control Eff ^{a,b}	Flare Exhaust	
				(ppmv) ^a	(lb/hr)		(lb/hr)	(tpy)
1,1,1 - Trichloroethane (methyl chloroform)	x	71-55-6	133.41	0.48	3.34E-02	98.0%	6.68E-04	2.93E-03
1,1,2,2 - Tetrachloroethane	x	79-34-5	167.85	1.11	9.72E-02	98.0%	1.94E-03	8.51E-03
1,1,2 - Trichloroethane (1,1,2 TCA)	x	79-00-5	133.41	0.10	6.96E-03	98.0%	1.39E-04	6.09E-04
1,1 - Dichloroethane (ethylidene dichloride)	x	75-34-3	98.96	2.35	1.21E-01	98.0%	2.43E-03	1.06E-02
1,1 - Dichloroethene (vinylidene chloride)	x	75-35-4	96.94	0.20	1.02E-02	98.0%	2.03E-04	8.90E-04
1,2 - Dichloroethane (ethylene dichloride)	x	107-06-2	98.96	0.41	2.10E-02	98.0%	4.20E-04	1.84E-03
1,2 - Dichloropropane (propylene dichloride)	x	78-87-5	112.99	0.18	1.06E-02	98.0%	2.12E-04	9.29E-04
2-Propanol (isopropyl alcohol)	--	67-63-0	60.11	50.1	1.57E+00	98.0%	3.14E-02	1.38E-01
Acetone (2-propanone)	--	67-64-1	58.08	7.01	2.12E-01	98.0%	4.25E-03	1.86E-02
Acrylonitrile (Propenenitrile)	x	107-13-1	53.06	6.33	1.75E-01	98.0%	3.50E-03	1.53E-02
Benzene	x	71-43-2	78.12	1.91	7.78E-02	98.0%	1.56E-03	6.82E-03
Bromodichloromethane	--	75-27-4	163.83	3.13	2.67E-01	98.0%	5.35E-03	2.34E-02
Butane	--	106-97-8	58.12	5.03	1.52E-01	98.0%	3.05E-03	1.34E-02
Carbon Disulfide	x	75-15-0	76.14	0.58	2.31E-02	98.0%	4.63E-04	2.03E-03
Carbon Tetrachloride	x	56-23-5	153.84	0.004	3.21E-04	98.0%	6.42E-06	2.81E-05
Carbonyl Sulfide	x	463-58-1	60.07	0.49	1.53E-02	98.0%	3.07E-04	1.34E-03
Chlorobenzene (monochlorobenzene)	x	108-90-7	112.56	0.25	1.49E-02	98.0%	2.98E-04	1.31E-03
Chlorodifluoromethane (CFC-22, freon-22)	--	75-45-6	86.47	1.30	5.86E-02	98.0%	1.17E-03	5.13E-03
Chloroethane (ethyl chloride)	x	75-00-3	64.52	1.25	4.21E-02	98.0%	8.41E-04	3.68E-03
Chloroform (trichloromethane)	x	67-66-3	119.38	0.03	1.87E-03	98.0%	3.74E-05	1.64E-04
Chloromethane (methyl chloride)	x	74-87-3	50.49	1.21	3.19E-02	98.0%	6.37E-04	2.79E-03
1,4 Dichlorobenzene (p-dichlorobenzene)	x	106-46-7	147	0.21	1.63E-02	98.0%	3.27E-04	1.43E-03
Dichlorodifluoromethane (CFC-12, freon-12)	--	75-71-8	120.91	15.7	9.90E-01	98.0%	1.98E-02	8.67E-02
Dichlorofluoromethane (freon-21)	--	75-43-4	102.92	2.62	1.41E-01	98.0%	2.81E-03	1.23E-02
Dichloromethane (methylene chloride)	x	75-09-2	84.93	14.3	6.33E-01	98.0%	1.27E-02	5.55E-02
Dimethyl Sulfide (methyl sulfide)	--	75-18-3	62.13	7.82	2.53E-01	98.0%	5.07E-03	2.22E-02
Ethane	--	74-84-0	30.07	889	1.39E+01	98.0%	2.79E-01	1.22E+00
Ethanol (ethyl alcohol)	--	64-17-5	46.08	27.2	6.54E-01	98.0%	1.31E-02	5.73E-02
Ethylbenzene ^c	x	100-41-4	106.17	4.61	2.55E-01	98.0%	5.10E-03	2.24E-02
Ethyl Mercaptan (ethanethiol)	--	75-08-1	62.13	1.25	4.05E-02	98.0%	8.10E-04	3.55E-03
Ethylene dibromide (1,2 dibromoethane)	x	106-93-4	187.88	0.001	9.80E-05	98.0%	1.96E-06	8.58E-06
Fluorotrichloromethane (CFC-11, freon-11)	--	75-69-4	137.37	0.76	5.44E-02	98.0%	1.09E-03	4.77E-03
Hexane	x	110-54-3	86.18	6.57	2.95E-01	98.0%	5.91E-03	2.59E-02
Hydrogen Sulfide	--	7783-06-4	34.08	385.8	6.86E+00	98.0%	1.37E-01	6.01E-01
Mercury (total)	x	7439-97-6	200.61	2.92E-4	3.05E-05	0.0%	3.05E-05	1.34E-04
Methyl Ethyl Ketone (2-butanone)	--	78-93-3	72.11	7.09	2.67E-01	98.0%	5.33E-03	2.34E-02
Methyl Isobutyl Ketone (hexone)	x	108-10-1	100.16	1.87	9.77E-02	98.0%	1.95E-03	8.56E-03
Methyl Mercaptan	--	74-93-1	48.11	2.49	6.25E-02	98.0%	1.25E-03	5.47E-03
Pentane	--	109-66-0	72.15	3.29	1.24E-01	98.0%	2.48E-03	1.08E-02
ethene)	x	127-18-4	165.83	3.73	3.23E-01	98.0%	6.45E-03	2.83E-02
Propane	--	74-98-6	44.1	11.1	2.55E-01	98.0%	5.11E-03	2.24E-02
Toluene (methylbenzene)	x	108-88-3	92.14	39.3	1.89E+00	98.0%	3.78E-02	1.65E-01
Trichloroethylene (trichloroethene)	x	79-01-6	131.38	2.82	1.93E-01	98.0%	3.86E-03	1.69E-02
t - 1,2 - Dichloroethene (1,2 dichloroethylene)	--	156-60-5	96.94	2.84	1.44E-01	98.0%	2.87E-03	1.26E-02
Vinyl Chloride (chloroethylene, VCM)	x	75-01-4	62.50	7.34	2.39E-01	98.0%	4.78E-03	2.10E-02
Xylenes (m, o, p)	x	1330-20-7	106.17	12.1	6.70E-01	98.0%	1.34E-02	5.87E-02
Hydrogen Chloride ^{c,d}	x	7647-01-0	36.50	42.0	7.99E-01	0.0%	7.99E-01	3.50E+00
Total HAP							0.91	3.97
Maximum Single HAP							0.80	3.50
Hydrogen Sulfide without BACT			34.08	5785.0	1.03E+02	98.0%	2.06	9.01

^aEPA 1998. "Compilation of Air Pollutant Emission Factors, Volume I. Stationary Point and Area Sources" (AP-42), 5th Ed., November

^bAP-42 gives ranges for control efficiencies. Control efficiencies for halogenated species range from 91 to 99.7 percent and control. Control efficiencies for non-halogenated species range from 38 to 91 percent. For permitting purposes, the lower end of each range is used here.

^cProduct of combustion

^dBecause HCl is a production of combustion, a default outlet concentration is listed; AP-42, Section 2.4.4.

Note: "x" denotes a HAP only or a HAP and VOC; "y" denotes a VOC only

EU003 - 3,000-scfm enclosed flare w/cvap
E-VAP UNIT #3016

THEORETICAL ORGANIC/METAL/OTHER CONCENTRATIONS and EMISSIONS

Leachate input Rate (gallons/day) = 30,000 gpd 0.030 MGD

COMPOUND	HAP	8/19/1998	4/29/1998	2/5/1998	11/5/1997	11/5/97 (a)	11/5/97 (a)	Maximum	EPA Theoretical Median Conc ⁽¹⁾ (mg/l)	EPA Theoretical Median Conc ⁽¹⁾ (ug/l)	Number of Samples by EPA	Max Conc (mg/l)	Pounds per hour	Pounds per year
		ppm ^b (mg/l)	ppm ^b (mg/l)	ppm ^b (mg/l)	ppm ^b (mg/l)	ppm ^b (mg/l)	ppb ^b (ug/l)							
1,1 Dichloroethane (ethylene dichloride)	*					0.0000		0.000	0.165	165	34	0.165	1.72E-3	15.08
1,1,1 Trichloroethane	*	5.00				0.0000		5.000	0	86	0	0.0000	0.00E+0	-
1,1,2 Trichloroethane	*					0.0000		0.000	0.086	426	20	5.0000	5.22E-2	456.85
1,1,2,2 Tetrachloroethane	*					0.0000		0.000	0.426	210	4	0.4260	4.44E-3	38.92
1,2 Dichloroethane (ethylene dichloride)	*					0.0000		0.000	0.21	10	1	0.2100	2.19E-3	19.19
1,2 Dichloropropane (propylene dichloride)	*					0.0000		0.000	0.01	9	6	0.0100	1.04E-4	0.91
1,2 trans dichloroethylene	*					0.0000		0.000	0.009	92	12	0.0090	9.39E-5	0.82
1,2,3 Trichloropropane	*					0.0000		0.000	0.092	230	40	0.0920	9.60E-4	8.41
1-Propanol	*					0.0000		0.000	0.23	11000	1	0.2300	2.40E-3	21.02
2,4-dimethylphenol	*					0.0000		0.000	11	1	1	11.0000	1.15E-1	1,005.08
2-Chloroethyl Vinyl Ether	*					0.0000		0.000	0.019	19	2	0.0190	1.98E-4	1.74
2-Hexanone	*					0.0000		0.000	0.551	551	2	0.5510	5.75E-3	50.35
Acetone	*					0.0880	88.00	0.088	0.088	88	11	0.0880	9.18E-4	8.04
Acrolein	*					0.0000		0.000	0.43	430	23	0.4300	4.49E-3	39.29
Acrylonitrile	*					0.0000		0.000	0.27	270	1	0.2700	2.82E-3	24.67
Benzene	*					0.0003	0.27	0.00027	0	37	0	0.0000	0.00E+0	-
Bis(Chloromethyl) Ether	*					0.0000		0.000	0.037	250	35	0.0370	3.86E-4	3.38
Butanol	*					0.0000		0.000	0.25	10000	1	0.2500	2.61E-3	22.84
Carbon tetrachloride	*					0.0000		0.000	10	202	1	10.0000	1.04E-1	913.71
Chlorobenzene	*					0.0000		0.000	0.202	7	2	0.2020	2.11E-3	18.46
Chloroform	*					0.0000		0.000	0.007	29	12	0.0070	7.30E-5	0.64
Chloromethane	*					0.0000		0.000	0.029	175	8	0.0290	3.02E-4	2.65
Cis- 1,2 Dichloroethylene	*					0.0000		0.000	0.175	330	3	0.1750	1.83E-3	15.99
Dichloromethane (methylene chloride)	*					0.0000		0.000	0.33	440	2	0.3300	3.44E-3	30.15
Diethyl phthalate	*					0.0000		0.000	0.44	83	68	0.4400	4.59E-3	40.20
Ethanol	*					0.0000		0.000	0	83	0	0.0000	0.00E+0	-
Ethylbenzene	*	3.00				0.0010	1.00	3.000	0.083	23000	27	0.0830	8.66E-4	7.58
Isophorone	*					0.0000		0.000	23	58	1	23.0000	2.40E-1	2,101.53
Methyl ethyl ketone	*					0.0000		0.000	0.058	76	41	3.0000	3.13E-2	274.11
Methyl isobutyl ketone	*					0.1900	190.00	0.190	0.076	1550	19	0.0760	7.93E-4	6.94
Naphthalene	*					0.0280	28	0.028	1.55	270	24	1.5500	1.62E-2	141.62
p-Cresol	*					0.0000		0.000	0.27	12	9	0.2700	2.82E-3	24.67
Perchloroethylene (tetrachloroethylene)	*					0.0000		0.000	0.012	2305	23	0.0120	1.25E-4	1.10
Phenols (total)	*					0.0000		0.000	2.305	55	10	2.3050	2.40E-2	210.61
Styrene	*					0.0000		0.000	0.055	378	18	0.0550	5.74E-4	5.03
Tetrahydrofuran	*					0.0000		0.000	0.378	0	45	0.3780	3.94E-3	34.54
Toluene	*	5.00		4.00	2.00	0.0026	2.60	5.000	0	260	0	0.0000	0.00E+0	-
Trichloroethylene	*					0.0000		0.000	0.26	413	7	0.2600	2.71E-3	23.76
Vinyl chloride	*					0.0000		0.000	0.413	43	69	5.0000	5.22E-2	456.85
Xylene	*	9.00				0.0000		0.000	0.043	40	28	0.0430	4.49E-4	3.93
						0.0022	2.20	9.000	0.04	71	10	0.0400	4.17E-4	3.65
									0.071	71	7	9	9.39E-2	822.34
Total HAP:													2.46E-1	2,156.07

Notes:
HAP = Clean Air Act Hazardous Air Pollutant
mgal = million gallons
Parts per billion = ug/l
Parts per million = mg/l

x - detected below method detection limit
(1) Using EPA "typical" leachate data (median value), Summary Of Data On Municipal Solid Waste Landfill
Leachate Characteristics "Criteria For Municipal Solid Waste Landfills"
EPA, July 1988 (NTIS PB88-24241).

Emissions Calculations
 Okeechobee (Berman Road) Landfill
 Okeechobee, FL

HAP	8/19/1998 ppm ^a (mg/l)	4/29/1998 ppm ^b (mg/l)	2/5/1998 ppm ^b (mg/l)	11/5/1997 ppm ^b (mg/l)	11/5/97 (a) ppm ^b (mg/l)	11/5/97 (a) ppb ^b (ug/l)	Maximum ppm ^b (mg/l)	EPA Theoretical Median Conc (mg/l)	EPA Theoretical Conc (ug/l)	Number of Samples by EPA	Max Conc (mg/l)	Pounds per hour	Pounds per year
Hydrogen Chloride ^(d)	*	660.00	320.00	260.00			660.000	695	695000	0	695.000	-	N/A
Hydrogen fluoride					200.00		200.000	0.4	400	0	200.000	-	N/A
Hydrogen sulfide ^(e)		96.00	8.00				96.000	108	108000	0	108.000	1.13E+0	9,868.04

Leachate HAPs & metals ^c	HAP	8/19/1998 ppm ^b (mg/l)	4/29/1998 ppm ^b (mg/l)	2/5/1998 ppm ^b (mg/l)	11/5/1997 ppm ^b (mg/l)	11/5/97 (a) ppm ^b (mg/l)	11/5/97 (a) ppb ^b (ug/l)	Maximum ppm ^b (mg/l)	EPA Theoretical Median Conc (mg/l)	EPA Theoretical Conc (ug/l)	Number of Samples by EPA	Max Conc (mg/l)	Pounds per hour	Pounds per year
Bis (Chloromethyl) ether	*					0.0000		0.000	0		0	0.000	0.00E+0	0.0
Isophorone	*					0.0000		0.000	0		0	0.000	0.00E+0	0.0
Naphthalene	*					0.0000		0.000	0		0	0.000	0.00E+0	0.0
p-cresol	*					0.0000		0.000	0		0	0.000	0.00E+0	0.0
phenols (total)	*					0.0000		0.000	0		0	0.000	0.00E+0	0.0
antimony	*					0.0000		0.000	0		0	0.000	0.00E+0	0.0
arsenic	*					0.0000		0.000	0.08		0	0.080	8.34E-7	0.0
barium	*	0.17	0.06	0.06	0.08	0.0000		0.170	0.383	383	0	0.383	3.99E-6	0.0
beryllium	*					0.0000		0.000	0.0065	7	0	0.007	6.78E-8	0.0
cadmium	*					0.0000		0.000	0.015	15	0	0.015	1.56E-7	0.0
calcium	*	135.00	21.00	25.00	27.00	0.0000		135.000	336	336000	0	336.000	3.50E-3	30.7
chromium	*	0.17				0.0000		0.170	0.06	60	0	0.170	1.77E-6	0.0
copper	*	0.10				0.0420	42.00	0.100	0.07	70	0	0.100	1.04E-6	0.0
lead	*					0.0000		0.000	0.08	80	0	0.080	8.34E-7	0.0
mercury	*					0.0000		0.000	0.0006	0.6	0	0.001	6.26E-9	0.0
nickel	*	0.20	0.03	0.02	0.02	0.0000		0.200	0.16	160	0	0.200	2.09E-6	0.0
selenium	*					0.0000		0.000		0	0	0.000	0.00E+0	0.0
sodium	*	510.00	260.00	330.00	440.00	0.0000		510.000		0	0	510.000	5.32E-3	46.6
thallium	*					0.0000		0.000		0	0	0.000	0.00E+0	0.0
iron	*	6.00				3.6000	3600.00	6.000	66.2	66200	0	66.200	6.90E-4	6.0
zinc	*	0.07				0.0750	75.00	0.075	1.35	1350	0	1.350	1.41E-5	0.1

TOTAL HAP EMISSIONS:

- a - HAPs in both LFG and in leachate
 - b - from EPA Characterization of MWC Ashes and Leachates from MSW Landfills, Monofills and Co-Disposal Sites, median concentration values
 - c - draft AP-42 (9/95), Tables 2.4-3; unfisted control efficiencies assumed to be 80%
 - d - product of combustion
 - e - Additional HAPs found in leachate > 50 ppb/mgal per reference b
 - x - HAP present in leachate > 50 ppb
 - o - non-VOC HAP
- Notes:
- c - draft AP-42 (9/95), Tables 2.4-1 and 2.4-2; concentration in inlet gas
 - d - concentration of chloride in leachate; thermal conversion to hydrogen chloride in flare is presented in the "air toxics" sheets
 - e - concentration of sulfate in leachate; thermal conversion to sulfur dioxides in flare is presented in the "criteria pollutants" sheets

uncontrolled = **0.30** **2,646.05**
 lb/hr **lbs/year**
 98% control = **0.006** **52.92**
 lb/hr **lbs/year**

EU005 3,000-scfm enclosed flare w/evap
E-VAP UNIT #PROPOSED on existing flare

THEORETICAL ORGANIC/METAL/OTHER CONCENTRATIONS and EMISSIONS

Leachate input Rate (gallons/day) = 30,000 gpd 0.030 MGD

COMPOUND	HAP	8/19/1998	4/29/1998	2/5/1998	11/5/1997	11/5/97 (a)	11/5/97 (a)	Maximum	EPA Theoretical Median Conc ⁽¹⁾ (mg/l)	EPA Theoretical Median Conc ⁽¹⁾ (ug/l)	Number of Samples by EPA	Max Conc (mg/l)	Pounds per hour	Pounds per year
		ppm ^b (mg/l)	ppm ^b (mg/l)	ppm ^b (mg/l)	ppm ^b (mg/l)	ppm ^b (mg/l)	ppb ^b (ug/l)	ppm ^b (mg/l)						
1,1 Dichloroethane (ethylidene dichloride)	*					0.0000		0.000	0.165	165	34	0.165	1.72E-3	15.08
1,1,1 Trichloroethane	*	5.00				0.0000		5.000	0		0	0.0000	0.00E+0	-
1,1,2 Trichloroethane	*					0.0000		0.000	0.086	86	20	5.0000	5.22E-2	456.85
1,1,2,2 Tetrachloroethane	*					0.0000		0.000	0.426	426	4	0.4260	4.44E-3	38.92
1,2 Dichloroethane (ethylene dichloride)	*					0.0000		0.000	0.21	210	1	0.2100	2.19E-3	19.19
1,2 Dichloropropane (propylene dichloride)	*					0.0000		0.000	0.01	10	6	0.0100	1.04E-4	0.91
1,2 trans dichloroethylene	*					0.0000		0.000	0.009	9	12	0.0090	9.39E-5	0.82
1,2,3 Trichloropropane	*					0.0000		0.000	0.092	92	40	0.0920	9.60E-4	8.41
1-Propanol	*					0.0000		0.000	0.23	230	1	0.2300	2.40E-3	21.02
2,4-dimethylphenol	*					0.0000		0.000	11	11000	1	11.0000	1.15E-1	1,005.08
2-Chloroethyl Vinyl Ether	*					0.0000		0.000	0.019	19	2	0.0190	1.98E-4	1.74
2-Hexanone	*					0.0000		0.000	0.551	551	2	0.5510	5.75E-3	50.35
Acetone	*					0.0880	88.00	0.088	0.088	88	11	0.0880	9.18E-4	8.04
Acrolein	*					0.0000		0.000	0.43	430	23	0.4300	4.49E-3	39.29
Acrylonitrile	*					0.0000		0.000	0.27	270	1	0.2700	2.82E-3	24.67
Benzene	*					0.0003	0.27	0.00027	0		0	0.0000	0.00E+0	-
Bis(Chloromethyl) Ether	*					0.0000		0.000	0.037	37	35	0.0370	3.86E-4	3.38
Butanol	*					0.0000		0.000	0.25	250	1	0.2500	2.61E-3	22.84
Carbon tetrachloride	*					0.0000		0.000	10	10000	1	10.0000	1.04E-1	913.71
Chlorobenzene	*					0.0000		0.000	0.202	202	2	0.2020	2.11E-3	18.46
Chloroform	*					0.0000		0.000	0.007	7	12	0.0070	7.30E-5	0.64
Chloromethane	*					0.0000		0.000	0.029	29	8	0.0290	3.02E-4	2.65
Cis- 1,2 Dichloroethylene	*					0.0000		0.000	0.175	175	3	0.1750	1.83E-3	15.99
Dichloromethane (methylene chloride)	*					0.0000		0.000	0.33	330	2	0.3300	3.44E-3	30.15
Diethyl phthalate	*					0.0000		0.000	0.44	440	68	0.4400	4.59E-3	40.20
Ethanol	*					0.0000		0.000	0		0	0.0000	0.00E+0	-
Ethylbenzene	*	3.00				0.0010	1.00	3.000	0.083	83	27	0.0830	8.66E-4	7.58
Isophorone	*					0.0000		0.000	23	23000	1	23.0000	2.40E-1	2,101.53
Methyl ethyl ketone	*					0.0000		0.000	0.058	58	41	3.0000	3.13E-2	274.11
Methyl isobutyl ketone	*					0.0280	28	0.028	0.076	76	19	0.0760	7.93E-4	6.94
Naphthalene	*					0.0000		0.000	0.190	190.00	24	1.5500	1.62E-2	141.62
p-Cresol	*					0.0000		0.000	0.27	270	9	0.2700	2.82E-3	24.67
Perchloroethylene (tetrachloroethylene)	*					0.0000		0.000	0.012	12	23	0.0120	1.25E-4	1.10
Phenols (total)	*					0.0000		0.000	2.305	2305	10	2.3050	2.40E-2	210.61
Styrene	*					0.0000		0.000	0.055	55	18	0.0550	5.74E-4	5.03
Tetrahydrofuran	*					0.0000		0.000	0.378	378	45	0.3780	3.94E-3	34.54
Toluene	*	5.00	4.00	2.00		0.0026	2.60	5.000	0		0	0.0000	0.00E+0	-
Trichloroethylene	*					0.0000		0.000	0.26	260	7	0.2600	2.71E-3	23.76
Vinyl chloride	*					0.0000		0.000	0.413	413	69	5.0000	5.22E-2	456.85
Xylene	*	9.00				0.0022	2.20	9.000	0.043	43	28	0.0430	4.49E-4	3.93
									0.04	40	10	0.0400	4.17E-4	3.65
									0.071	71	7	9	9.39E-2	822.34

Notes:
HAP = Clean Air Act Hazardous Air Pollutant
mgal = million gallons
Parts per billion = ug/l
Parts per million = mg/l

Emissions Calculations
Okeechobee (Berman Road) Landfill
Okeechobee, FL

x - detected below method detection limit

(1) Using EPA "typical" leachate data (median value), Summary Of Data On Municipal Solid Waste Landfill Leachate Characteristics "Criteria For Municipal Solid Waste Landfills"

EPA, July 1988 (NTIS PB88-242441).

	HAP	8/19/1998 ppm ^b (mg/l)	4/29/1998 ppm ^b (mg/l)	2/5/1998 ppm ^b (mg/l)	11/5/1997 ppm ^b (mg/l)	11/5/97 (a) ppm ^b (mg/l)	11/5/97 (a) ppb ^b (ug/l)	Maximum ppm ^b (mg/l)	EPA Theoretical Median Conc (mg/l)	EPA Theoretical Conc (ug/l)	Number of Samples by EPA	Max Conc (mg/l)	Pounds per hour	Pounds per year
Hydrogen Chloride ^(d)	*	660.00	320.00	260.00				660.000	695	695000	0	695.000	-	N/A
Hydrogen fluoride						200.00		200.000	0.4	400	0	200.000	-	N/A
Hydrogen sulfide ^(d)		96.00	8.00					96.000	108	108000	0	108.000	1.13E+0	9,868.04

	HAP	8/19/1998 ppm ^b (mg/l)	4/29/1998 ppm ^b (mg/l)	2/5/1998 ppm ^b (mg/l)	11/5/1997 ppm ^b (mg/l)	11/5/97 (a) ppm ^b (mg/l)	11/5/97 (a) ppb ^b (ug/l)	Maximum ppm ^b (mg/l)	EPA Theoretical Median Conc (mg/l)	EPA Theoretical Conc (ug/l)	Number of Samples by EPA	Max Conc (mg/l)	Pounds per hour	Pounds per year
Leachate HAPs & metals^c														
Bis (Chloromethyl) ether	*					0.0000		0.000	0		0	0.000	0.00E+0	0.0
Isophorone	*					0.0000		0.000	0		0	0.000	0.00E+0	0.0
Naphthalene	*					0.0000		0.000	0		0	0.000	0.00E+0	0.0
p-cresol	*					0.0000		0.000	0		0	0.000	0.00E+0	0.0
phenols (total)	*					0.0000		0.000	0		0	0.000	0.00E+0	0.0
antimony	*					0.0000		0.000	0		0	0.000	0.00E+0	0.0
arsenic	*					0.0000		0.000	0.08		0	0.080	8.34E-7	0.0
barium	*	0.17	0.06	0.06	0.08	0.0000		0.170	0.383	383	0	0.383	3.99E-6	0.0
beryllium	*					0.0000		0.000	0.0065	7	0	0.007	6.78E-8	0.0
cadmium	*					0.0000		0.000	0.015	15	0	0.015	1.56E-7	0.0
calcium	*	135.00	21.00	25.00	27.00	0.0000		135.000	336	336000	0	336.000	3.50E-3	30.7
chromium	*	0.17				0.0000		0.170	0.06	60	0	0.170	1.77E-6	0.0
copper	*	0.10				0.0420	42.00	0.100	0.07	70	0	0.100	1.04E-6	0.0
lead	*					0.0000		0.000	0.08	80	0	0.080	8.34E-7	0.0
mercury	*					0.0000		0.000	0.0006	0.6	0	0.001	6.26E-9	0.0
nickel	*	0.20	0.03	0.02	0.02	0.0000		0.200	0.16	160	0	0.200	2.09E-6	0.0
selenium	*					0.0000		0.000		0	0	0.000	0.00E+0	0.0
sodium	*	510.00	260.00	330.00	440.00	0.0000		510.000		0	0	510.000	5.32E-3	46.6
thallium	*					0.0000		0.000		0	0	0.000	0.00E+0	0.0
iron	*	6.00				3.6000	3600.00	6.000	66.2	66200	0	66.200	6.90E-4	6.0
zinc	*	0.07				0.0750	75.00	0.075	1.35	1350	0	1.350	1.41E-5	0.1

TOTAL HAP EMISSIONS:

a - HAPs in both LFG and in leachate

b - from EPA Characterization of MWC Ashes and Leachates from MSW Landfills, Monofills and Co-Disposal Sites, median concentration values

c - draft AP-42 (9/95), Tables 2.4-3; unlisted control efficiencies assumed to be 80%

d - product of combustion

c - Additional HAPs found in leachate > 50 ppb/mgal per reference b

x - HAP present in leachate > 50 ppb

o - non-VOC HAP

Notes:

c - draft AP-42 (9/95), Tables 2.4-1 and 2.4-2; concentration in inlet gas

d - concentration of chloride in leachate; thermal conversion to hydrogen chloride in flare is presented in the "air toxics" sheets

d - concentration of sulfate in leachate; thermal conversion to sulfur dioxides in flare is presented in the "criteria pollutants" sheets

uncontrolled = **0.30** **2,646.05**
lb/hr lbs/year

98% control = **0.006** **52.92**
lb/hr lbs/year

Note: Existing 20,000-gpd EVAP unit contributed 35.3 lb/yr. Increase for new unit = 35.3

**Emissions Calculations
Okeechobee (Berman Road) Landfill
Okeechobee, FL**

Letter Symbol	Definition
atm-ft ³ /lb-mol°R	atmosphere cubic foot per pound mole degree Rankine
acfm	actual cubic foot per minute
atm	atmosphere
bhp	brake horsepower
Btu	british thermal unit
cal/s	calorie per second
CO	carbon monoxide
ft ³	cubic foot
m ³	cubic meter
d	day
°F	degree Fahrenheit
°R	degree Rankine
dscfm	dry standard cubic foot, feet per minute
dsl/min	dry standard litre per minute
ft	foot
ft/min	foot per minute
ft/s	foot per second
g	gram
hr	hour
HAP	hazardous air pollutant
HV	heating value
HHV	higher heating value
in.	inch
kW	kilowatt
kWh	kilowatt hour
l	litre
LHV	lower heating value
m	meter
m/s	meter per second
CH ₄	methane
Hg	mercury
µg	microgram
µg/dsl	microgram per dry standard litre
mg	milligram
MM	million
MMBtu	million british thermal units
min	minute
mol	mole
NO ₂	nitrogen dioxide
Nox	nitrogen oxides
NMOC	non-methane organic compounds
PM ₁₀	particulate matter less than or equal to 10 microns
Pb	lead
ppmv	parts per million by volume
ppmw	parts per million by weight
lb/hr	pound per hour
s	second
scf	standard cubic foot
scfm	standard cubic foot per minute
STP	standard temperature and pressure
SO ₂	sulfur dioxide
ton	ton
ton/yr	ton per year
R	universal gas constant
VOC	volatile organic compound

Sample Calculations

Standard Conditions and Constants

$$^{\circ}\text{R} = ^{\circ}\text{F} + 460$$

standard temperature = 60 °F

standard pressure = 1 atm

Universal gas constant (R) = 0.7302 atm-ft³/lb-mol^oR

Flow

$$\text{dscfm} = \text{scfm} * (1 - \% \text{moisture})$$

$$\text{acfm} = \text{scfm} * \left(\frac{\text{actual temp}[^{\circ}\text{R}]}{\text{standard temp}[^{\circ}\text{R}]} \right) * \left(\frac{\text{standard press}[\text{atm}]}{\text{actual press} [\text{atm}]} \right)$$

CO and NO_x Emissions

$$(\text{lb/MMbtu}) * (\text{MMbtu/hr}) = \text{lb/hr}$$

SO₂ Emissions

typically, 86% to 99.7% of sulfur compounds convert to SO₂ during combustion

$$\{(\text{scfm}) * (60 \text{ min/hr}) * (\text{total sulfur concentration} [\text{ppmv}]) * (1 - \text{control efficiency}) * (\text{MW SO}_2)\} / \{(R) * (T)\} = \text{lb/hr}$$

PM₁₀ Emissions

$$(\text{dscfm}) * (\text{CH}_4 \text{ component}) * (1\text{E-}6 \text{ MMscf/scf}) * (\text{lb PM/MMscf CH}_4) * (60 \text{ min/hr}) = \text{lb/hr}$$

VOC Emissions

$$\{(\text{scfm} * 60 \text{ min/hr} * \text{concentration}_{\text{compound}}[\text{ppmv}] * \text{MW}_{\text{compound}}) / (R) * (T)\} * (1 - \text{control efficiency}) = \text{lb/hr}$$

OR

VOCs are 39 percent of NMOC, as prescribed in AP-42

VOC concentration [ppmv] = NMOC concentration [as hexane] * 39%

flare and/or engines typically combust 98% of VOCs

$$\{(\text{scfm} * 60 \text{ min/hr} * \text{concentration}_{\text{hexane}}[\text{ppmv}] * \text{MW}_{\text{hexane}}) / (R) * (T)\} * (0.39) = \text{lb/hr}$$

LFG Compound Emissions

$$\{(\text{scfm} * 60 \text{ min/hr} * \text{concentration}_{\text{compound}}[\text{ppmv}] * \text{MW}_{\text{compound}}) / (R) * (T)\} * (1 - \text{control efficiency})$$

HCl Emissions

typically, 86% to 99.7% of chlorine compounds convert to HCl during combustion

(concentration_{compound} [ppm]) * (control efficiency) * (no. of chlorine atoms) = HCl concentration [ppm] in outlet gas from each compound

$$(\text{HCl concentration}_{\text{each compound}} [\text{ppm}] * \text{scfm} * \text{MW}_{\text{HCl}}) / \{(R) * (T)\} * (60 \text{ min/hr}) = \text{lb/hr}$$

OR

$$\{(\text{scfm}) * (60 \text{ min/hr}) * (\text{HCl outlet concentration per AP-42} [\text{ppmv}]) * (1 - \text{control efficiency}) * (\text{MW}) / \{(R) * (T)\} = \text{lb/hr}$$

Sample Calculations

Standard Conditions and Constants

°R = °F + 460
 standard temperature = 60 °F
 standard pressure = 1 atm
 Universal gas constant (R) = 0.7302 atm-ft³/lb-mol°R

Flow

dscfm = scfm*(1-%moisture)
 acfm = scfm*(actual temp[°R])/(standard temp[°R])*{(standard press[atm])/(actual press [atm])}

CO and NO_x Emissions

(lb/MMbtu)*(MMbtu/hr) = lb/hr

SO₂ Emissions

typically, 86% to 99.7% of sulfur compounds convert to SO₂ during combustion
 {(scfm)*(60 min/hr)*(total sulfur concentration [ppmv])*(1-control efficiency)*(MW SO₂)} / {(R)*(T)} = lb/hr

PM₁₀ Emissions

(dscfm)*(CH₄ component)*(1E-6 MMscf/scf)* (lb PM/MMscf CH₄)*(60 min/hr) = lb/hr

VOC Emissions

{(scfm*60 min/hr*concentration_{compound}[ppmv]*MW_{compound})/(R)*(T)}*(1-control efficiency) = lb/hr
 OR

VOCs are 39 percent of NMOC, as prescribed in AP-42

VOC concentration[ppmv] = NMOC concentration[as hexane]*39%

flare and/or engines typically combust 98% of VOCs

{(scfm*60 min/hr*concentration_{hexane}[ppmv]*MW_{hexane})/(R)*(T)}*(0.39) = lb/hr

LFG Compound Emissions

{(scfm*60 min/hr*concentration_{compound}[ppmv]*MW_{compound})/(R)*(T)}*(1-control efficiency)

HCl Emissions

typically, 86% to 99.7% of chlorine compounds convert to HCl during combustion

(concentration_{compound} [ppm])*(control efficiency)*(no. of chlorine atoms) = HCl concentration [ppm] in outlet gas from each compound

{HCl concentration_{each compound} [ppm]*scfm*MW_{HCl}}/(R)*(T)*(60 min/hr) = lb/hr

OR

{(scfm)*(60 min/hr)*(HCl outlet concentration per AP-42 [ppmv])*(1-control efficiency)*(MW)}/(R)*(T)} = lb/hr

INTENTIONALLY LEFT BLANK

Ohio EPA
Division of Air Pollution Control
Air Quality Modeling and Planning Section
Engineering Guide #69
Air Dispersion Modeling Guidance

2003

The Division of Air Pollution Control has received several questions concerning computer modeling of air pollution sources. This guide is intended to respond to those questions. Below is a list of all of the questions. The rest of the Guide contains the Division's responses. The Division welcomes comments on the application of this Guide and additional questions related to air dispersion modeling.

This document will answer the most commonly asked questions to provide a basis for consistent model application although many other questions require case-specific responses. The answers in this document do not reflect a rule or regulation, are not intended to be treated as a rule or regulation, and are subject to change on a case-by-case basis. The information within is provided so that permitting personnel, regulated entities and the public will have an understanding of the expected outcome of the situations described in this document. If you have additional questions on modeling, or comments on this guide, you should contact the Division of Air Pollution Control (614-644-2270).

.....
Table of Contents

Questions and Answers.....pg 2
APPENDIX A.....pg 29

TABLES

Table 1; Meteorological Assignmentspg 24
**Table 2; National Weather Service Anemometer
Heights and Station Numbers.....pg 27**
**Table 3; Threshold Emission Rates and
Target Concentrationspg 28**

Question 1: What specific modeling requirements are incorporated by Ohio EPA in the review of air contaminant sources?

Question 2: What models are to be used?

Question 3: What meteorological data sets are to be used?

Question 4: What modeled emission rate(s) should be used?

Question 4.1: Are fugitive emissions modeled?

Question 4.2: Are there any exceptions to the modeling thresholds for modeling criteria pollutants and toxics contained in Table 3?

Question 4.3: Should sources be modeled that emit pollutants listed in the ACGIH book, do not have a TWA, but do have a Ceiling or STEL?

Question 4.4: Are minor and exempt sources included in the modeling for a project which exceeds the thresholds in Table 3?

Question 4.5: Do you model sources within a building that have no direct vent to the outside or do not have an identified control device for capture, control and release of the emissions from the unit?

Question 5: Is building downwash required for state modeling?

Question 5.1: What building height do I use if the building has a pitched roof?

Question 6: Reserved/Deleted

Question 7: Is there any special guidance for nonstandard point source emissions?

Question 7.1: How do I model rain caps and horizontal releases?

Question 7.2: How do I model flares?

Question 7.3: What special modeling considerations are necessary for modeling combustion turbines?

Question 8: Reserved/Deleted

Question 9: What receptor grids must I use?

Question 10: What are the state significant emission rates which trigger modeling?

Question 10.5: Can a source modification trigger a requirement for modeling even where there is no increase in emission rate?

Question 11: What are the state target concentrations for acceptable incremental impacts?

Question 12: What special requirements exist for sources of fluoride?

Question 13: How do I obtain background values when performing NAAQS analyses in Ohio?

Question 14: What sources do I include in a major source PSD and/or NAAQS analysis?

Question 15: How do I model major sources in nonattainment areas to demonstrate net air quality improvement?

Question 16: Can I use SCREEN to model multiple sources?

Question 17: If multiple pollutants are being emitted, does an individual model run have to be performed for each pollutant?

Question 18: For PSD and non-PSD sources, can facilities be installed if modeling shows that more than ½ the available PSD increment is consumed?

Question 19: What determines whether a locale is rural or urban?
.....

Question 1: What specific modeling requirements are incorporated by Ohio EPA in the review of air contaminant sources?

Answer 1: The following is intended to identify current Ohio EPA, Division of Air Pollution Control requirements for air pollution control modeling applications within Ohio. Where applicable, Ohio EPA is consistent with U.S. EPA guidance. In real world applications, the US EPA Guideline on Air Quality Models and supplementary guidance does not always address detailed problems that confront modelers.

The purpose of air dispersion modeling is to predict pollutant concentrations resulting from a source or group of sources under various meteorological conditions. Modeling is necessary to demonstrate that the subject source or sources will not 1) cause or significantly contribute to a violation of the National Ambient Air Quality Standards (NAAQS); 2) cause ambient concentrations which exceed allowable PSD increments; 3) comply with Ohio EPA's policy of no new source consuming more than one half of the available PSD increment (one half the increment is the effective goal for all new source modeling of criteria pollutants, regardless of the size or location of the new source.); and/or 4) cause ground level concentrations which exceed Ohio EPA's maximum allowable ground level concentration (MAGLC) for toxic air pollutants. For criteria pollutants which do not have identified PSD increments, maximum incremental impact of new source emissions is limited to one quarter of the NAAQS.

The combined emission increases from all of the new or modified sources must be evaluated to determine the maximum incremental impact if the total emissions exceed the amounts indicated in Table 3. For criteria pollutants, the incremental impact cannot exceed one half of any PSD increment or, if no PSD increment exists, one quarter of the NAAQS. There is no requirement to model VOC emissions for incremental impact on ozone concentrations (although specific VOC constituents may require air toxic modeling). **For exceptions to the one half PSD increment policy, see Answer 18.**

New or increased emissions of toxics that exceed the levels identified in Table 3 must be evaluated to determine the maximum incremental impact of these emissions for comparison with the MAGLC as described in Ohio EPA's current procedure for reviewing new sources of air toxics.

Where the permit includes both emission increases and decreases (generally restricted to a contemporaneous 5-year period), the net increase should be modeled. Ohio EPA must approve the 'netting' emissions prior to modeling.

Question 2: What models are to be used?

Answer 2: The specific source/receptor situation dictates the appropriate model for determining ambient concentrations for comparison with NAAQS, PSD increments, short or long term exposure limits, etc. The size and complexity of the source, the

toxicity of the emissions along with other factors will dictate whether a screening model or a refined model is appropriate.

Screening models are generally the first level tools for evaluating air quality impacts. High predicted concentrations from a screening model may indicate the need for further refined modeling. Larger more significant sources and groups of sources will require the application of a refined model.

Sources in areas where terrain elevation is significant relative to the stack height will require evaluation using receptor elevations. Where terrain exceeds the stack height, a complex or intermediate terrain modeling analysis is necessary. This applies to both criteria and toxic pollutants.

Generally, the most recent version of a model is to be used. The most recent model versions of models contained in The Guideline on Air Quality Models (GAQM) can be obtained by accessing the U.S. EPA Support Center for Regulatory Air Models (SCRAM), Technology Transfer Network at <http://www.epa.gov/ttn/scram>. The SCRAM web page also provides model users manuals, ancillary programs, meteorological data and additional model application information. This Engineering Guide and meteorological data for Ohio sources are available on the Ohio EPA DAPC web page located at <http://www.epa.state.oh.us/dapc/aqmp/aqmp.html>

Note: The Guideline on Air Quality Models (Appendix W of 40 CFR Part 51) will be revised. AERMOD has been identified as the replacement for the ISC models. Federal guidance has indicated that both AERMOD and ISC will be acceptable for no more than one year after the final rule is published. At which time ISC will no longer be acceptable for PSD and SIP related modeling. Ohio EPA will continue to accept ISC for state-only permits and modeling projects until further notice.

Screening models:

Note: There is currently no screening version of AERMOD to replace SCREEN3. Until further notice, SCREEN3 will still be accepted by Ohio EPA for state-only permit modeling.

The current recommended model for screening point or area sources in simple terrain is the most recent version of SCREEN3 (or its successor), for criteria pollutants or for applications where maximum ambient concentrations of neutral buoyancy pollutants are desired. A fundamental assumption for pollutants being modeled with traditional Gaussian models is that the concentration of the pollutant in the plume will not make the plume disperse or diffuse differently than air.

Applications requiring an evaluation of emergency release scenarios or sources emitting 'light' or 'heavy' plumes may use one of the commercially available toxic

release models to determine if ambient impacts exceed the applicable MAGLC. Most routine releases, even of heavy compounds, will have a density close to that of air due to high dilution.

Point sources with stacks less than good engineering height (discussed below) must be evaluated for downwash impacts using the SCREEN3 or SCREEN3C model (or their successors).

Initial screening estimates of source impacts involving intermediate or complex terrain should utilize SCREEN3 or TSCREEN (or their successors). SCREEN3 is available as an interactive program by itself or within the TSCREEN model set.

The output from these models identifies short term (1-hour) maximum impacts. The following are the conversion factors to be used to convert these short term estimates to the averaging time of concern. Separate conversion factors have been recommended by U.S. EPA for terrain below stack tip (simple terrain) and terrain above stack tip (complex terrain).

Conversion Factors

Model output	Desired Averaging Period						
	1-hr	3-hr	8-hr	24-hr	month	qtr	ann
Simple 1-hr:	1.000	0.900	0.700	0.400	0.180	0.130	0.080
Complex 1-hr	1.000	0.700	0.500	0.150		0.060	0.030

Additional guidance on the use of SCREEN and TSCREEN is provided in Appendix A of this document.

Complex and intermediate terrain screening for state-only permit requirements can also be performed using ISC3 with five years of NWS data.

Refined models:

The most commonly used refined models for point, area and volume sources involving simple, intermediate and complex terrain are the most recent versions of ISCST3 and ISCLT3 (or their successors) using representative meteorological data in the regulatory default modes. Several commercial versions of these models have been granted model equivalency by U.S. EPA and are therefore also acceptable. For refined toxic analyses, the same procedures used for criteria pollutants are used to determine ambient concentrations. There are currently no requirements for deposition calculations. Modeling involving pollutant transformations (ozone, nitrates, sulfates) is not generally required for new or modified sources and is not addressed in this guide.

Question 3: What meteorological data sets are to be used?

Answer 3: Short Term: ISC Data Sets: Hourly surface observations are combined with twice-daily mixing height measurement to create a RAMMET meteorological input file. RAMMET data files can be created using on-site tower measurements or off-site National Weather Service (NWS) surface data sets.

If the modeling is for NAAQS or PSD analyses, at least one year of on-site or the most recent available five years of representative off-site NWS data are required. If the source of concern is located in intermediate or complex terrain, U.S. EPA believes that NWS data are not representative for the above stack portion of the analysis and are therefore not acceptable. For state-only modeling requirements, 5 years of NWS data are considered acceptable for use in a conservative screening analysis.

The most recent five-year off-site NWS data sets currently available from Ohio EPA are for the period 1987-1991. These data are acceptable. Later NWS data are also acceptable but not required. Off-site NWS data sets are assigned by county. Table 1 identifies the appropriate data set for each county in Ohio.

Certain southeastern counties of the state have been assigned Parkersburg/Huntington RAMMET and STAR data for modeling. For counties assigned 'Parkersburg' surface data, 1973-1977 data are the most recent available. This surface site is the most representative available for modeling in this region of Ohio and the older data set is considered more representative for these counties than more recent Huntington or Pittsburgh data.

NOTE: While the State of Ohio accepts NWS data for use in modeling in both simple and complex terrain for state-only modeling requirements, U.S. EPA has a more restrictive interpretation of 'representative' meteorological data when modeling impacts at receptors with elevations above the stack tip. For this and other reasons, it is important when preparing to model major PSD or nonattainment sources, that a protocol is developed and approved to assure that acceptable model calculations will be obtained for each source/receptor relationship.

AERMOD Data Sets: On-site or NWS surface data sets are combined with local surface characteristics and upper air observations within the AERMET preprocessor program to create the needed modeling meteorological data sets for AERMOD. The latest five-year data sets for use in Ohio will be provided on the Ohio EPA web page at <http://www.epa.state.oh.us/dapc/aqmp/aqmp.html> after Appendix W is finalized and final guidance is issued by U.S. EPA.

Long term: Long term (e.g., monthly, quarterly, annually) meteorological data sets are developed from short term on-site or off-site (NWS) surface data sets. These long term STAR (STability ARray) data sets are necessary to run ISCLT3 or other ISCLT3-based

long term models.

ISCST3 and AERMOD can also be used for long term modeling periods by modeling specific blocks of days and selecting appropriate n-day average concentrations.

Question 4: What modeled emission rate(s) should be used?

Answer 4: Tables 9-1 and 9-2 in the Guideline on Air Quality Models (Appendix W of 40 CFR Part 51) identify the various emission rates to be used in modeling a source. In general, the short term maximum potential (allowable) emission rate is used in the evaluation of a short term standard. For an existing source, a representative long term actual emission rate can be used to evaluate a longer term (quarterly or annual) standard. An annual permit restriction can also be used to develop a long term average emission rate to be used in evaluating a long term standard for a new source.

For state permit modeling, including Ohio air toxics modeling, the peak short term increase which the permit will allow is the emission rate to be modeled to determine the peak ambient impact this permit action will allow. This could involve the combined peak impact of several sources if there are several sources included in the same project.

For a federal netting or synthetic minor permit, the difference between existing actuals emissions and permit allowable emissions, as determined in the netting calculation, is modeled for comparison to the Ohio acceptable incremental impacts. For state-only netting modeling evaluations, the allowable to allowable difference is usually acceptable. For PSD or federal netting, though, modeled emissions should be consistent with the netting evaluation performed for the permit.

For a modification which involves an emission increase only, the net change allowed by the permit is evaluated. For PSD and other federal analyses, the net change is the difference between the existing actual emissions and the new potential allowable emissions. For state-only review, modeling the difference in allowables is usually acceptable.

For a modification involving a change in stack parameters which could increase the ambient impact due to the source(s), the emissions affected by the modification (potential allowable) are modeled to determine if the impact of the modification is below the Ohio acceptable incremental impacts. If necessary, the present (before modification) emissions can be modeled as negatives in a refined analysis to determine the net impact of the permitted modification for comparison to the Ohio acceptable incremental impacts.

Like-kind replacements would not need modeling if all emissions parameters remain the same since there would be no increase in impact due to the permit action. If, however, the replacement involves the use of a shorter stack, lower temperatures, etc., the

replacement may cause an increased peak impact which would need evaluation. As noted above, if the replacement, when viewed alone, exceeds the Ohio acceptable incremental impacts as identified in Table 3, the source being replaced can be modeled with a negative emission rate in a refined modeling analysis to determine the net peak impact for comparison to the Ohio acceptable incremental impacts. Also, see Question 14 for additional information on emission inventories.

Question 4.1: Are fugitive emissions modeled?

Answer 4.1: Major new source PSD and Nonattainment Review includes all significant sources, including fugitive sources such as storage piles and roadways.

In minor source state permit modeling, though, only the boiler or process source criteria and toxic emissions increases (both controlled and fugitive) are to be modeled. Non-process fugitive sources such as roadways and parking lots, material storage and material transfer operations are not modeled. Grinding, crushing, mixing and screening operations are considered processes and should be modeled. An evaluation of all project emissions may be required in a state analysis if circumstances warrant.

Question 4.2: Are there any exceptions to the modeling thresholds for modeling criteria pollutants and toxics contained in Table 3?

Answer 4.2: There are several new source emissions scenarios which Ohio EPA has historically not reviewed for state-only permits. These scenarios generally involve fugitive emissions from parking lots, roadways, material handling and storage piles. These scenarios usually represent situations where modeling results often indicate potential problems due to unreliable emission factors and/or unusual or extreme source configurations. Field experience with these sources, though, indicates that normal operating practices and compliance with required controls result in acceptable ambient impacts as demonstrated by ambient monitoring, field measurements of visible emissions or a lack of verified complaints by local citizens.

Therefore, the following list of source/pollutant scenarios will not be required to perform an air quality analysis in support of a state-only permit **unless factors such as source size, tons of emissions, particle size, pre-existing concerns or proximity to other sources or citizen populations indicate that a modeling review is warranted:**

- Toxic or criteria pollutants from parking lots
- Toxic or criteria pollutants from storage piles
- Toxic or criteria pollutants from storage tanks
- Toxic or criteria pollutants from transfer operations
- Toxic or criteria pollutants from grain silos or dryers

Toxic or criteria pollutants from emergency generators
Toxic or criteria pollutants from gasoline dispensing

In addition, the following pollutants will be treated as PM but not as a toxic for modeling purposes:

Wood dust
Sand
Glass dust
Coal dust
Silica
Grain dust

Source/Toxic Pollutant combinations subject to a MACT, NESHAP or an NSPS that would restrict the amount of that pollutant that could be released are not subject to toxics modeling. Toxics modeling is also not required for pollutants subject to a NAAQS (e.g., lead).

Question 4.3: Should sources be modeled that emit pollutants listed in the ACGIH book, do not have a TWA, but do have a Ceiling or STEL?

Answer 4.3: Yes, pollutants not having a listed TWA are addressed by multiplying the Ceiling or STEL by 0.737 and then following the procedures in 'Option A' to develop a MAGLC.

Question 4.4: Are minor and exempt sources included in the modeling for a project which exceeds the thresholds in Table 3?

Answer 4.4: All sources or units contained in the permits that make up a project are initially considered significant with respect to the potential impact due to the project. Many small sources, while individually insignificant, could combine to cause or contribute to an ambient problem. Smaller sources can be removed from the modeling analysis if it can be demonstrated that their emissions are insignificant relative to the rest of the project.

Question 4.5: Do you model sources within a building that have no direct vent to the outside or do not have an identified control device for capture, control and release of the emissions from the unit?

Answer 4.5: Sources can be located within an enclosure or building with no obvious control and/or vent moving the emissions to the outside. It must be assumed that all

emissions coming from the device are either captured and controlled or are escaping to ambient air. If they are not being captured and controlled (with the cleaned air being reintroduced to the work area), the emissions must be escaping the building and the modeler must determine how the emissions are being removed from the building or enclosure to the ambient air. The emission rate leaving the building or enclosure is assumed to be the same as the emission rate from the source(s). Any credit for some portion of the emissions being retained in the building due to "building capture" must be supportable and will be evaluated on a case-by-case basis.

Often the emissions are removed by the building ventilation system. In other situations, the only exchange between indoor and outdoor air occurs through open doors and windows. In any event, the modeler must identify the egress point(s) and characterize the releases as one of the available modeling release scenarios (i.e., point, area or volume). If best engineering judgement justifies assigning a fraction of the total emissions through specific egress points, the individual points can be modeled with their assigned emission rates. When using a single source screening model, the individual modeled peaks are then added together.

If it is unclear which potential egress point the emissions are actually venting through, the worst case egress point is assumed. If it is not clear which egress point is worst case, each scenario should be tested.

Question 5: Is building downwash required for state modeling?

Answer 5: Any stack source file must include building dimension data if the stack is not at or above good engineering practice (GEP) stack height. GEP is determined by evaluating all nearby structures using the formula $GEP = H + 1.5L$ where H is the height of the structure and L is the lesser of the height or projected width of the structure. The GEP height is the highest height calculated for any nearby structure (a structure is 'nearby' if it is within five times the lesser of its height or width from the stack). If direction specific building dimensions (discussed below) are not calculated, the most conservative dimensions should be used for all directions. The most conservative building dimensions are usually associated with the height and diagonal width of the tallest nearby building.

Direction specific building dimensions may be determined for 36 wind directions for ISCST or AERMOD and 16 wind directions for ISCLT. This allows the model to include the effects of the critical structure for each wind direction. Direction specific building dimensions are calculated using facility plot plans and manually determining the dominant structure dimensions for each wind direction for each stack. Alternatively, the BPIP program provided by the U.S. EPA as well as several commercial software packages are available which will calculate the dimensions for each wind direction from a single building or group of buildings for each stack.

Buildings with multiple segments can be viewed as multiple buildings. For example, a predominantly flat one story building is interrupted by a three-story tower, the flat, one story building is evaluated and the 'four story' building (1 + 3), with lateral dimensions of the tower is also evaluated.

Building dimensions are not contained in state or federal emissions data bases. These data need to be obtained from facility personnel if sources at that facility are subject to building downwash. Distant background sources might be modeled without downwash with Ohio EPA permission since this would most likely maximize those sources' impact in the study area and therefore be 'conservative'.

Question 5.1: What building height do I use if the building has a pitched roof?

Answer 5.1: Pitched roofs present a nonstandard modeling scenario. The horizontal dimensions at the peak are reduced to a single line. A conservative approach is to assume that the entire horizontal dimensions are covered by a flat roof at the elevation of the peak of the pitched roof. An acceptable alternative is to assume a building height one half the distance up the pitched roof and the corresponding horizontal dimensions below that 'roof' (i.e., one horizontal dimension would also be halved).

Question 7: Is there any special guidance for nonstandard point source emissions?

Answer 7: Nonstandard source emissions are not specifically addressed in the above screening or refined models. For example, if emissions do not exit the stack in an upward (vertical) direction, alternative characterizations of the source should be developed to more accurately represent the release point. If a 'point source' is still assumed, even though the exit velocity is blocked or diverted sideways or downward (such as in a rain cap, discussed below), an exit velocity of 0.001 m/s should be input to the model so that a fictitious upward momentum is not credited to that source.

If the temperature of the release is near ambient, a characterization as an area or volume source might be appropriate. If temperature is significant, a virtual stack might be created to represent the emission point. Alternative characterizations should be discussed with Ohio EPA staff prior to modeling.

Question 7.1: How do I model rain caps and horizontal releases?

Answer 7.1: U.S. EPA has provided a specific solution to address hot stack plumes that are interrupted by a rain cap or which are released horizontally. U.S. EPA requires that these sources reduce their stack exit velocity to 0.001 m/s.

While it would be conservative to simply reduce the velocity, the source would lose the effect of the buoyancy that the volume of hot gas would normally have. The Ohio EPA recommended adjustment provides for retention of the buoyancy while addressing the impediment to the vertical momentum of the release. The procedure is as follows (stack parameters' units are assumed to be in metric units):

1) The stack exit velocity (V_s) is set equal to 0.001 m/s (V_s')

2) Stack diameter (d_s) is adjusted using the equation

$$d_s' = 31.6 * d_s * (V_s)^{0.5}$$

(Where V_s is the actual stack exit velocity, NOT 0.001 m/s)

3) Use V_s' and d_s' in the model

The results of this approach can create an extremely large modeled stack diameter. Receptors should not be placed within the calculated diameter, d_s' .

Question 7.2: How do I model flares?

Answer 7.2: For screening purposes, the flare option in SCREEN3 or TSCREEN is acceptable. For refined modeling, it is necessary to compute equivalent emission parameters, i.e., adjusted values of temperature and stack height and diameter. Several methods appear in the literature, none of which seems to be universally accepted. Ohio EPA/DAPC has used the following procedure, which is believed to be consistent with SCREEN3:

- 1) compute the adjustment to stack height as a function of heat release Q in MMBtu/hr:

$$H_{\text{equiv.}} = H_{\text{actual}} + 0.944(Q)^{0.478} \quad (a)$$

Where H has units of meters;

- 2) assume temperature of 1273 deg. K;
- 3) assume exit velocity of 20 meters/sec;
- 4) assume the following buoyant flux:

$$F_b = 1.162(Q)$$

- 5) back-calculate the stack diameter that corresponds to the above assumed parameters. Recall the definition of buoyant flux:

$$F_b = 3.12(V)(T_{\text{stack}} - T_{\text{ambient}})/T_{\text{stack}}$$

Where V is the volumetric flow rate, actual m³/sec.

Substituting for F_b and solving for the equivalent stack diameter d_{equiv.}:

$$d_{\text{equiv.}} = 0.1755(Q)^{0.5}$$

This method pertains to the "typical" flare, and will be more or less accurate depending on various parameters of the flare in question, such as heat content and molecular weight of the fuel, velocity of the uncombusted fuel/air mixture, presence of steam for soot control, etc. Hence, this method may not be applicable to every situation, and the applicant may submit his own properly documented method.

(a) Beychok, M., 1979. Fundamentals of Stack Gas Dispersion, Irvine, CA.

Question 7.3: What special modeling considerations are necessary for modeling combustion turbines?

Answer 7.3: Combustion turbines are unique in that stack temperatures and flow rates, as well as emission rates, are dependant on ambient conditions, especially ambient temperature. Determining a worst case operating scenario resulting in peak source impacts involves evaluating the source at multiple loads (50%, 75% and 100%) as well as average and extreme ambient temperatures. Three general approaches are normally followed to establish the worst case operating scenario. The approaches described below address a PSD application.

Approach 1: Each scenario is modeled using SCREEN3. If each scenario results in insignificant impact, then the demonstration is complete. If one or more scenarios result in significant impact, the worst case scenario is carried forward into the PSD and NAAQS analyses using ISC or AERMOD. If there is no clear cut worst case scenario, multiple scenarios may need to be carried forward into the subsequent comprehensive analyses. All other things being equal, it is preferable to move forward with a 100% load scenario rather than a reduced load scenario.

Approach 2: Each scenario is modeled with ISC or AERMOD using the latest year of meteorology. The worst case scenario(s) is then run with five years of meteorology to determine if the proposed project will have a significant impact. If there is a significant impact, then the worst case scenarios are carried forward into the PSD and NAAQS analyses.

Approach 3: Worst case emission rates and stack parameters from all scenarios are used to estimate a worst case impact. This virtual worst case stack can be used through all phases of the analysis.

The same approaches can be followed for state-only (e.g., synthetic minors) modeling, with the only goal to be achieved being the Ohio Acceptable Incremental Impacts.

Question 9: What receptor grids must I use?

Answer 9: Sufficient receptors are necessary in the vicinity of projected maximum concentrations to assure that the peak concentration(s) has been found. For most applications, the spacing should be 100 meters at the 'hotspot', determined from the preliminary modeling results (either ISC, AERMOD or a screening model), out to a distance sufficient to assure that the maximum concentration has been found. Additional receptors should also be placed in areas of special concern (e.g., areas of source interaction and areas of significant terrain). It is also important that the extent of the grid covers the entire area of significant impact from the proposed project.

Receptor elevations are required unless a demonstration that the study area is flat is made. The absence of terrain above stack height is not sufficient to ignore terrain heights. 'Simple' terrain does not mean 'flat' terrain. Topographical data indicating no significant terrain features in the expected significant impact area of the source(s) or indicating flat but gently sloping terrain could justify not including terrain heights for the receptors in that study area.

Receptor elevation information as well as source and receptor location information can be derived from information contained on United States Geological Service topographical maps as well as from internet sources such as www.topozone.com. Information is also available from Digital Elevation Model (DEM) files which are also available from various host sites on the internet. DEM files are available free of charge at <http://data.geocomm.com/dem/>.

AERMOD receptor grids must be exclusively developed using the AERMAP preprocessor using DEM data. Receptor information must contain calculated information concerning the relative height of the nearby terrain (receptor height scales) in addition to the location and elevation of the receptor.

Question 10: What are the state significant emission rates which trigger modeling?

Answer 10: A comprehensive list of emission rates which trigger state and federal modeling requirements is contained in Table 3 under the heading "Ohio Modeling Significant Emission Rates." The emissions increase which will be allowed by this permit action (potential allowable increase) are compared to these levels.

Question 10.5: Can a source modification trigger a requirement for modeling even where there is no increase in emission rate?

Answer 10.5: OAC 3745-31-01(VV)(1)(b) defines "modification" to include "Any physical change in, or change in the method of operation of any significant air contaminant source that, for the specific air contaminant . . . for which the source is classified as significant, results in an increase in the ambient air quality impact . . ." greater than certain values specified in the rule. Thus, if the source is "significant" (as defined in OAC 3745-31-01(RRR)) and the proposed incremental impact at any receptor exceeds the specified value (listed under the "3745-31-01(VV)(1)(b)" heading in Table 3) then the change is a modification requiring a permit-to-install, notwithstanding the fact that it may entail no increase in emissions.

It should be kept in mind that the provisions for OAC 3745-31-01(VV)(1)(b) were promulgated for the sole purpose of ensuring that the ambient air quality standards are protected. If this provision is triggered, BAT is not required. Also, this provision is not required under any federal regulation and has not been submitted to U.S. EPA for approval as part of the SIP.

It should also be noted that the concentrations in (VV) are only trigger concentrations and are not maximum allowable impacts. The ambient air quality standards and, if applicable, the PSD increments would be the limiting factor.

An example is a coal-fired boiler where a scrubber is proposed to be installed to remove sulfur dioxide. Even though the actual and allowable emissions of NO_x might not increase, the reduced stack temperature and velocity associated with the scrubber could result in an increase of ambient concentration at some receptor exceeding the 15 ug/m³ limit under (VV)(1)(b), thereby triggering the requirement to obtain a PTI before beginning construction. Another example is any reduction of stack height. For either example the need for modeling is apparent, to resolve the PTI question. A screening model may be used, or if a refined model is selected, the controlling concentration will be the high-high increase of concentration anywhere on the receptor grid, for the relevant averaging period, using five years of off-site or one-year of on-site meteorological data.

Question 11: What are the state target concentrations for acceptable incremental impacts?

Answer 11: Table 3 also contains a listing of national ambient air quality standards and PSD increments as well as state target ambient concentrations for criteria pollutants and specific toxic emissions subject to the state air toxic policy. The state target concentrations for criteria and toxic pollutants listed under the heading "Ohio Acceptable Incremental Impact" represent the acceptable incremental impact of the new emissions which are the subject of a state permit requirement. The Ohio

significant impacts under OAC 3745-31-01 (VV)(1)(b) identify modeled impact levels which trigger permit to install requirements for a source modification (including stack height changes).

Question 12: What special requirements exist for sources of fluoride?

Answer 12: The potential for secondary impacts due to fluorides is greater than the probability for primary human health effects. Therefore, there may be observable impacts and actual complaints of damage to plants and property when the MAGLC has not been exceeded.

The approach to follow when evaluating the secondary impacts due to fluorides is as follows. The secondary 'target' is 0.5 ug/m^3 as a 30-day average. The screening approach is to model a 1-hour concentration using SCREEN and convert it to a 'monthly' average using the 0.18 conversion. Monthly averages can also be modeled directly using ISCST or ISCLT or AERMOD. The incremental impact of the new emissions is modeled.

This 'secondary' approach would also be appropriate for any other pollutants where it is determined that there may be significant non health related impacts at levels below the MAGLC.

Question 13: How do I obtain background values when performing NAAQS analyses in Ohio?

Answer 13: Modeling analyses which must estimate total concentrations of a pollutant (e.g., PSD analyses which evaluate the NAAQS) must account for those sources which are either too small or too distant to be included in the modeling analysis. This is accomplished by adding a background value to the modeled concentrations.

A separate background value is needed for each NAAQS pollutant and for each NAAQS averaging time. Actual monitored data for the most recent year, from a representative monitoring site(s) are the basis for acceptable background values. Ideally, the monitor should not be impacted by any major sources or any local smaller sources. If an unimpacted monitor is available, the second highest value for each short-term period would represent the short term backgrounds. The annual average is the annual background. The highest quarterly average would be used for lead.

If an unimpacted monitor is not available, nonimpacted values from monitors which are near a limited number of sources and which have nonimpacted sectors (no upwind sources) can be used to develop background values. **Unadjusted impacted monitor values can also be used as a conservative background.**

A nonimpacted value is a monitored value measured during a period when the wind was not blowing from a 90-degree sector centered on a line between the monitor and the potentially impacting source. For a 3-hour value, no winds should be from the impacting sectors. For 24-hour values, no more than two hours should have winds from the impacting sectors. For short term backgrounds, the second highest nonimpacted value is chosen as a fixed background. Long term background values are the average of the nonimpacted values for the specific averaging time period.

Question 14: What sources do I include in a major source PSD and/or NAAQS analysis?

Answer 14: Major Source NAAQS Analysis: All sources within the significant impact area (SIA) of the emissions increase with potential allowable emissions greater than the PSD significant emission rates (listed in Table 3), must be included in a new source review NAAQS analyses. SIA is defined as the region over which any exceedance of a PSD significant impact increment (listed in Table 3) occurs, based on each high-high concentration over five years of modeling (one year if on-site, representative data are available). In addition, all major sources with potential allowable emissions greater than 100 tons/yr outside of the SIA and within 50 km must also be included if they interact with the new source.

Whether to include a potentially interacting source can be determined using the '20D' approach. Under this approach, the modeler may exclude sources whose potential allowable emissions in tons/yr are less than 20 times the distance between the two sources in kilometers. Prior to commencement of final modeling, though, Ohio EPA must be advised as to what sources the modeler chooses to exclude using the 20D method. Ohio EPA reserves the right to require any or all of these sources to be included in a final analysis if Ohio EPA believes that any or all are potentially significant.

Major Source PSD Increment Analysis: All PSD sources located within an area where PSD baseline has been triggered or within the SIA of the new source, whichever is larger, must be included in the PSD increment analysis modeling inventory. PSD sources located outside of the baseline area or SIA which interacts with the new source must also be included. These sources may be screened using the 20D approach.

Inventory data should be obtained from the state emissions inventory system or the AIRS national data base system. Basic modeling source parameters (stack height or release height, diameter, temperature, exit velocity or volume flow, emission rate, etc.) are contained in these data systems.

The DAPC emissions inventory unit has placed several data sets on the Ohio EPA web page at: <http://www.epa.state.oh.us/dapc/eqmp/eiu/eiu.html>. While the later data sets have significant amounts of current information, it is important to check the 1990 and 1995 data bases which contain information on short term allowable emission rates.

The short term allowable rates and source capacities are included in these earlier data sets. These are important for determining maximum short term allowable emission rates for the significant sources consistent with Section 9.1 of the GAQM. If source information is missing or is suspect, you will need to contact the local air pollution agency or field office to obtain current, correct information.

Question 15: How do I model major sources in nonattainment areas to demonstrate net air quality improvement?

Answer 15: OAC 3745-31-25 discusses the requirements for determination of net air quality benefit for major sources wishing to locate in a nonattainment area (NAA). Both the rule and U.S. EPA guidance indicate the need for demonstrating area-wide benefit and progress toward attainment.

VOC emissions are not required to be modeled for net air quality benefit. All major PM and SO₂ emissions increases and corresponding offsetting emissions will need to be modeled for a net air quality benefit. The entire state is attainment for CO, NO_x and Pb so no net air quality benefit modeling is required.

In general, PM and SO₂ NAAs have undergone SIP modeling at some time and the state has identified receptor areas which were key for the SIP attainment demonstrations. In cases where the potential offsets could impact critical receptors, those receptors must show impacts less than or equal to zero. For the remaining receptors, the receptors within the significant impact area of the increasing emissions must, on average, show no net increase for each averaging period.

If greater than zero impacts at critical receptors or net area-wide increases are modeled, the applicant may present a complete NAAQS demonstration for the significant impact area of the project.

Question 16: Can I use SCREEN to model multiple sources?

Answer 16: While the SCREEN model is a single-source model, it can be used to develop a conservative estimate of the peak potential impact of emissions from multiple egress locations.

A conservative approach combines the peak impact from each individual SCREEN run as if the peak impact from each emission point occurred at the same point in space.

In the case of multiple identical stacks, all of the emissions can be assumed to come from one stack (modeled using the combined emission rate with the stack flow parameters for a single stack).

If the egress points are not identical, all of the emission could be to assume to be emitted from the 'worst case' emission point. Sometimes the determination of worst case is straightforward (e.g., shortest, coldest, lowest flow stack). In other situations, the choice may not be clear and the Local Air Agency, District Office or Central Office should be consulted.

The approaches described above will result in conservative estimates. If the source(s) does not pass using the above assumptions, less conservative approaches can be considered in consultation with the Local Air Agency, District Office or Central Office. A multisource refined model may also be appropriate to use to model the actual separation of emission points and estimate their combined peak impact.

Question 17: If multiple pollutants are being emitted, does an individual model run have to be performed for each pollutant?

Answer 17: If the emission characteristics are identical for each pollutant (all of the pollutants are emitted in the same proportion from each of the egress points) one run can be performed and the results can be adjusted. Gaussian models such as AERMOD, SCREEN and ISC are 'linear' models in that the impacts will vary proportionally to the emission rate. Therefore, in this example case, if one pollutant is being emitted at twice the rate of another pollutant, the impact of the second pollutant will be twice as high.

In the case of multiple pollutants being emitted from a single emission point, an emission rate of 1 gram per second can be modeled and the results multiplied by each allowable emission rate (expressed in grams per second) to determine the predicted ambient concentration of each of the pollutants.

If emission characteristics vary for different pollutants, or the pollutants do not vary proportionately from each egress point, then a separate modeling analysis for each pollutant is necessary.

Question 18: For PSD and non-PSD sources, can facilities be installed if modeling shows that more than ½ the available PSD increment is consumed?

Answer 18: The purpose of PSD is to keep clean areas clean. The intent of the one half increment portion of the policy is to allow future growth by preventing any single emissions increase from consuming all of the available increment.

Non-PSD sources still consume increment and increase background concentrations. Therefore, these emissions can also threaten future growth.

As such, it is Ohio EPA's practice that any new source, whether PSD or not, will not

consume more than one half the available PSD increment (In application, state-only permits do not involve modeling which would assess available increment, therefore, one half the increment is the effective goal.) .

In some cases, Ohio EPA will grant exceptions to this policy for new PSD or non-PSD sources where modeling predicts exceedances of one half of, but less than 83 percent of the available increment. (For example: If the available increment were 30 ug/m³, between 15 and 25 ug/m³.) Exceptions will be granted on a case-by-case basis (but only when public health will not be adversely affected or where modeling results are suspect). The following are examples of where exceptions will be granted:

- 1) Modeling shows that the exceedance of the one half of the available increment occurs in a very localized area near the emissions source either due to the source parameters or due to downwash and, in the Ohio EPA's judgement, it is unlikely that other new sources located near the facility will significantly impact the same exceedance locations. In other words, if it is unlikely that another source would be negatively impacted by the exceedance then the Ohio EPA may grant the exception. An example of this would be a fugitive source with low release points having close proximity maximum impact areas that in the Ohio EPA's judgement would not be areas that other facilities would impact.
- 2) If the source is located such that it is unlikely in the Ohio EPA's judgement that any other major source would locate in the same area (for instance, in an extremely remote, rural area).
- 3) If the source is temporary and the increment consumed will become available in the near future for future growth (for instance, at a clean up site where the source will be operated for only a couple of years.)
- 4) If the source is locating in a 'brownfield' area and otherwise would locate in a greenfield site.

Question 19: What determines whether a locale is rural or urban?

Answer 19: The Guideline on Air Quality Models-(Appendix W of 40 CFR Part 51) outlines two methods by which an area can be categorized as either 'urban' or 'rural'. These methods rely on evaluating either the land use or population density within a three-kilometer radius circle around the subject source. Either of these methods is acceptable for the determination of the proper classification for that source, although the land use approach is preferred.

In Ohio, many counties have had significant SIP development modeling performed which included sources from across the county. Due to the inability of the models used to incorporate both rural and urban in a single run, a single, predominate classification

was assigned for the entire county. Therefore, if multiple facilities over a wider area are being modeled as part of a PSD or NAAQS analysis, the Central Office should be consulted as to the historic classification for the overall analysis so that a consistent approach will be maintained.

WFS/JTT/wfs

July 1, 2003

Appendix A.....pg 29

SCREEN/TSCREEN Model Application Guidance

Point Sourcepg 29

Area Sourcepg 30

Volume Sourcepg 30

TABLES

Table 1; Meteorological Assignmentspg 24

Table 2; National Weather Service Anemometer
Heights and Station Numbers.....pg 27

Table 3; Threshold Emission Rates and
Target Concentrationspg 28

Table 1

METEOROLOGICAL ASSIGNMENTS

(meteorological years 1987-1991 unless otherwise specified)

<u>COUNTY</u>	<u>SURFACE</u>	<u>MIXING HEIGHT</u>
ADAMS	Huntington	Huntington
ALLEN	Dayton	Dayton
ASHLAND	Akron	Pittsburgh
ASHTABULA	Erie	Buffalo
ATHENS	Parkersburg	Huntington (1973-1977)
AUGLAIZE	Dayton	Dayton
BELMONT	Pittsburgh	Pittsburgh
BROWN	Cincinnati	Dayton
BUTLER	Cincinnati	Dayton
CARROLL	Pittsburgh	Pittsburgh
CHAMPAIGN	Dayton	Dayton
CLARK	Dayton	Dayton
CLERMONT	Cincinnati	Dayton
CLINTON	Cincinnati	Dayton
COLUMBIANA	Pittsburgh	Pittsburgh
COSHOCTON	Columbus	Pittsburgh
CRAWFORD	Columbus	Dayton
CUYAHOGA	Cleveland	Buffalo
DARKE	Dayton	Dayton
DEFIANCE	Fort Wayne	Flint
DELAWARE	Columbus	Dayton
ERIE	Cleveland	Buffalo
FAIRFIELD	Columbus	Dayton
FAYETTE	Columbus	Dayton
FRANKLIN	Columbus	Dayton
FULTON	Toledo	Flint
GALLIA	Huntington	Huntington
GEAUGA	Cleveland	Buffalo
GREENE	Dayton	Dayton
GUERNSEY	Pittsburgh	Pittsburgh
HAMILTON	Cincinnati	Dayton
HANCOCK	Toledo	Dayton
HARDIN	Dayton	Dayton

METEOROLOGICAL ASSIGNMENTS

HARRISON	Pittsburgh	Pittsburgh
HENRY	Toledo	Flint
HIGHLAND	Cincinnati	Dayton
HOCKING	Columbus	Huntington
HOLMES	Akron	Pittsburgh
HURON	Cleveland	Buffalo
JACKSON	Huntington	Huntington
JEFFERSON	Pittsburgh	Pittsburgh
KNOX	Columbus	Dayton
LAKE	Cleveland	Buffalo
LAWRENCE	Huntington	Huntington
LICKING	Columbus	Dayton
LOGAN	Dayton	Dayton
LORAIN	Cleveland	Buffalo
LUCAS	Toledo	Flint
MADISON	Columbus	Dayton
MAHONING	Youngstown	Pittsburgh
MARION	Columbus	Dayton
MEDINA	Akron	Pittsburgh
MEIGS	Parkersburg	Huntington (1973-1977)
MERCER	Fort Wayne	Dayton
MIAMI	Dayton	Dayton
MONROE	Parkersburg	Pittsburgh (1973-1977)
MONTGOMERY	Dayton	Dayton
MORGAN	Parkersburg	Huntington (1973-1977)
MORROW	Columbus	Dayton
MUSKINGUM	Columbus	Pittsburgh
NOBLE	Parkersburg	Pittsburgh (1973-1977)
OTTAWA	Toledo	Flint
PAULDING	Fort Wayne	Dayton
PERRY	Columbus	Huntington
PICKAWAY	Columbus	Dayton
PIKE	Huntington	Huntington
PORTAGE	Akron	Pittsburgh
PREBLE	Dayton	Dayton
PUTNAM	Fort Wayne	Dayton
RICHLAND	Columbus	Dayton
ROSS	Columbus	Dayton

METEOROLOGICAL ASSIGNMENTS

SANDUSKY	Toledo	Flint
SCIOTO	Huntington	Huntington
SENECA	Toledo	Dayton
SHELBY	Dayton	Dayton
STARK	Akron	Pittsburgh
SUMMIT	Akron	Pittsburgh
TRUMBULL	Youngstown	Pittsburgh
TUSCARAWAS	Akron	Pittsburgh
UNION	Columbus	Dayton
VAN WERT	Fort Wayne	Dayton
VINTON	Huntington	Huntington
WARREN	Cincinnati	Dayton
WASHINGTON	Parkersburg	Huntington (1973-1977)
WAYNE	Akron	Pittsburgh
WILLIAMS	Toledo	Flint
WOOD	Toledo	Flint
WYANDOT	Columbus	Dayton

Table 2

**National Weather Service Anemometer Heights
and Station Number**

<u>Site</u>	<u>Anemometer Height</u>	<u>Station Number</u>
Akron/Canton	20 feet	14895
Cincinnati/Covington	20 feet	93814
Cincinnati/Abbe Obs.	51 feet	93890
Cleveland	10 meters	14820
Columbus	20 feet	14821
Dayton	22 feet	93815(surface)
Dayton (Wright Pat)	NA	13840(upper air)
Mansfield	20 feet	14891
Toledo	30 feet	94830
Youngstown	20 feet	14852
Buffalo, NY	10 meters	14733
Erie, Pa.	20 feet	14860
Flint, Mi.	21 feet	14826
Fort Wayne, In.	20 feet	14827
Huntington, WV	20 feet	03860
Charleston WV	117 feet	13866
Elkins WV	20 feet	13729
Pittsburgh, Pa.	20 feet	94823
Parkersburg, WV	100 feet	13867

**Table 3
Federal and State Modeling Standards and Significant Emission Rates**

POLLUTANT	AVERAGING PERIOD	National Ambient Air Quality Standards (NAAQS) (ug/m ³)						OHIO	OHIO	
					PSD	PSD	PSD	MODELING	SIGNIFICANT	OHIO
				CLASS II	SIGNIFICANT	SIGNIFICANT	MONITORING	SIGNIFICANT	IMPACTS	ACCEPTABLE
				PSD	EMISSION	IMPACT	DE MINIMIS	EMISSION	UNDER	INCREMENTAL
				INCREMENTS	RATES	INCREMENTS	CONC	RATES	3745-31-01(vv)	IMPACT
	PRIMARY	SECONDARY	(ug/m ³)	(tons/year)	(ug/m ³)	(ug/m ³)	(tons/year)	(ug/m ³)	3745-31-01(vv)	(ug/m ³)
PM10	Annual	50 a	c	17 a	15	1 h	-	10		8.5 a
	24-Hour	150 b	c	30 b	-	5 h	10 h	-	10 (24-hr TSP) i	15 b
Sulfur Dioxide	Annual	80 a	c	20 a	40	1 h	-	25		10 a
	24 Hour	365 b	c	91 b	-	5 h	13 h	-	15 i	45.5 b
	3-Hour	-	1300 b	512 b	-	25 h	-	-		256 b
Nitrogen Dioxide	Annual	100 a	c	25 a	40	1 h	14 h	25	15 (24-hr) i	12.5 a
Ozone	1-Hour	244 d	c	--	40 e	--	-	-		
Carbon Monoxide	8-Hour	10,000 b	c	--	100	500 h	575 h	100	575ia	2500 b
	1-Hour	40,000 b	c	-	--	2000 h		-		10000 b
Lead	Calendar Quarter	1.5 a	c	-	0.6	--	0.1 h	0.6	0.1 i	0.375 a
Toxics Listed by ACGIH f	1-Hour	--	-	--	-	--	-	1		g, a

a Concentration not to be exceeded
b Concentration not to be exceeded more than once per year
c Same as primary NAAQS.
d Not to be exceeded on more than one day per year, three year average.
e Emissions of volatile organic compounds.
f Any toxics included in the latest handbook of The American Conference of Governmental Industrial Hygienists.
g Value calculated by procedure outlined in current version of the Ohio EPA Division of Air Pollution Control document entitled "Review of New Sources of Air Toxic Emission"
h Peak concentration.
i Concentration that initiates PTI requirements

Appendix A

SCREEN/TSCREEN Model Application Guidance

The type of SCREEN source to be chosen is dependant on how the emissions leave the source (if the source is not enclosed) or how they leave the building or enclosure if emitted within a building or enclosure. Once the egress points are identified and characterized, one of the following source types is applied to the emissions at the point of egress (stack, window, vent, etc.)

The following information identifies the SCREEN/TSCREEN model choices to be used when modeling for Ohio new source review. Since the TSCREEN model does not directly identify which release scenarios lead to the use of the SCREEN model, "TSCREEN pathways" are identified to assist TSCREEN users in making scenario choices that will lead to the SCREEN model and the desired source type.

Point Source

TSCREEN pathways; There are several TSCREEN release scenarios which utilize the SCREEN3 point source option including Gaseous Release Type, Stacks, Vents, Conventional Point Sources or Particulate Matter Release Type, Stacks, Vents.

- Emission rate (g/s)
- Stack Height (above ground, not roof (m))
- Stack inside diameter (m, diameter of equivalent area circle if stack is not round)
- Stack exit velocity (m/s) or flow rate (ACFM or m³/s)
- Stack gas temperature (K)
- Ambient temperature (use default of 293 K)
- Receptor height above ground (use 0, ground level)
- Urban/Rural (based on land use within 3 km of the source)
- Building downwash (Building information is necessary if stack is within the influence of a building: i.e., within five times the lesser building dimension)
- Do not consider building cavity calculations. **Note:** After mmm dd, 2002, AERMOD will replace ISC and be the only acceptable refined model. This model does incorporate building wake and cavity effects. After mmm dd, 2002, users of SCREEN will also need to consider the building cavity calculations when determining peak impacts.
- Complex terrain (yes if terrain above stack height is present in the potential impact area of the source)
- Simple or flat (yes for simple: if terrain above stack base is present in the potential impact area of the source. When in doubt, say yes and perform the analysis)
- Choice of meteorology (option 1, full meteorology)
- Automated distance array (yes, minimum distance (m) begins at "ambient air" (usually the fence line) and should extend to a point which ensures that the

- maximum concentration has been found, up to a maximum of 50,000 m)
- Discrete distance option (used for informational purposes only)
- Fumigation Option (fumigation calculations are not used for state permit modeling)

Area Source

TSCREEN pathway: There are several TSCREEN pathways which utilize the SCREEN3 area source option including Particulate Matter Release Type, Fugitive/Windblown Dust Emissions or Storage Piles or Gaseous Release Type, Multiple Fugitive Sources. The TSCREEN pathways **do not** allow the characterization of non-square area sources which is now an option with SCREEN3.

General option choices are the same as for point source except for the following;

- Emission rate (g/s/m²)
- Source height (mean height of source, m)
- Length of longer side of rectangular area, (m)
- Length of shorter side of rectangular area, (m)
- Wind direction search (yes)

Volume Source

TSCREEN pathway:(the SCREEN volume source option is not available through TSCREEN)

General options choices are the same as for point source except for the following;

- Initial lateral dimension (modified per table below (m))
- Initial vertical dimension (modified per table below (m))
- Height of release (the midpoint of the opening (m))

SUMMARY OF SUGGESTED PROCEDURES FOR ESTIMATING INITIAL LATERAL DIMENSIONS (σ_{y0}) AND INITIAL VERTICAL DIMENSIONS (σ_{z0}) FOR VOLUME SOURCES

Description of Source	Initial Dimension
(a) Initial Lateral Dimensions (σ_{y0})	
Single Volume Source	$\sigma_{y0} =$ length of side divided by 4.3
(b) Initial Vertical Dimensions (σ_{z0})	
Surface-Based Source ($h_e \sim 0$)	$\sigma_{z0} =$ vertical dimension of source divided by 2.15
Elevated Source ($h_e > 0$) on or Adjacent to a Building	$\sigma_{z0} =$ building height divided by 2.15

Elevated Source ($h_e > 0$) not on or
Adjacent to a Building

$\sigma_{z0} =$ vertical dimension of source
divided by 4.3

Appendix B

From: Pakrasi, Arijit
Sent: Tuesday, November 21, 2006 4:55 PM
To: Blinn, Leah
Subject: FW:
Please put this up in the portal for records

thanks

*Arijit Pakrasi, Ph.D., P.E.
Senior Consultant
Shaw Environmental, Inc.
2790 Mosside Boulevard
Monroeville, PA 15146
Ph: 412 858 3921
Fax: 412 372 8968
email: arijit.pakrasi@shawgrp.com*

-----Original Message-----

From: Nelson, Deborah [mailto:Deborah.Nelson@dep.state.fl.us]
Sent: Tuesday, November 21, 2006 4:50 PM
To: Pakrasi, Arijit
Subject:

Just use SCREEN3 for your screening analysis. The AERSCREEN is a beta version and is not ready for distribution.

Debbie Nelson
Meteorologist
Air Permitting South
850-921-9537
deborah.nelson@dep.state.fl.us

SOLAR TURBINES INCORPORATED
ENGINE PERFORMANCE CODE REV. 3.40
JOB ID:

DATE RUN: 22-Dec-06
RUN BY: Donald C Lyons

--- SUMMARY OF ENGINE EXHAUST ANALYSIS ---
POINT NUMBER 1

GENERAL INPUT SPECIFICATIONS

ENGINE FUEL: CHOICE NATURAL GAS
29.88 in Hg AMBIENT PRESSURE
60.0 percent RELATIVE HUMIDITY
0.0038 --- SP. HUMIDITY (LBM H2O/LBM DRY AIR)

FUEL GAS COMPOSITION (VOLUME PERCENT)

LHV (Btu/Scf) = 454.7 SG = 1.0366 W.I. @60F (Btu/Scf) = 446.6

Methane (CH4) = 49.9999
Carbon Dioxide (CO2) = 49.9999
Sulfur Dioxide (SO2) = 0.0001

*** Wobbe Index of fuel gas is outside of standard gaseous fuel ***
** limits per ES 9-98. Please submit SER for this application. **

*** Landfill and digester gas sources must be disclosed to
Solar Turbines via an SER. Landfill and digester gases
may contain Siloxanes which cause rapid deterioration of
performance and component life. ***

*** Methane content less than 80%. ***
** Please submit SER for this application. **

GENERAL OUTPUT DATA

20617.	lbm/hr	FUEL FLOW
5747.	Btu/lbm	LOWER HEATING VALUE
455.	Btu/Scf	LOWER HEATING VALUE
77379.	Scfm	EXHAUST FLOW @ 14.7 PSIA & 60F
200336.	Acfm	ACTUAL EXHAUST FLOW CFM
354239.	lbm/hr	EXHAUST GAS FLOW
4214.7	deg R	ADIA STOICH FLAME TEMP, CHOICE GAS
4674.0	deg R	ADIA STOICH FLAME TEMP, SDNG
28.96	---	MOLECULAR WEIGHT OF EXHAUST GAS
16.24	---	AIR/FUEL RATIO

EXHAUST GAS ANALYSIS

ARGON	CO2	H2O	N2	O2	
0.88	5.60	6.15	73.28	14.08	VOLUME PERCENT WET
0.93	5.97	0.00	78.08	15.01	VOLUME PERCENT DRY
4283.	30169.	13556.	251097.	55126.	lbm/hr
0.21	1.46	0.66	12.18	2.67	G/(G FUEL)

- WARNING!!! PLEASE SUBMIT FUEL SUITABILITY -
- INQUIRY TO SAN DIEGO!!!!!!!!!!!!!!!!!!!!!! -

SOLAR TURBINES INCORPORATED
ENGINE PERFORMANCE CODE REV. 3.40
JOB ID:

DATE RUN: 22-Dec-06
RUN BY: Donald C Lyons

--- SUMMARY OF ENGINE EXHAUST ANALYSIS ---
POINT NUMBER 2

GENERAL INPUT SPECIFICATIONS

ENGINE FUEL: CHOICE NATURAL GAS

29.88 in Hg AMBIENT PRESSURE
60.0 percent RELATIVE HUMIDITY
0.0064 --- SP. HUMIDITY (LBM H2O/LBM DRY AIR)

FUEL GAS COMPOSITION (VOLUME PERCENT)

LHV (Btu/Scf) = 454.7 SG = 1.0366 W.I. @60F (Btu/Scf) = 446.6

Methane (CH4) = 49.9999
Carbon Dioxide (CO2) = 49.9999
Sulfur Dioxide (SO2) = 0.0001

*** Wobbe Index of fuel gas is outside of standard gaseous fuel ***
** limits per ES 9-98. Please submit SER for this application. **

*** Landfill and digester gas sources must be disclosed to
Solar Turbines via an SER. Landfill and digester gases
may contain Siloxanes which cause rapid deterioration of
performance and component life. ***

*** Methane content less than 80%. ***
** Please submit SER for this application. **

GENERAL OUTPUT DATA

19862. lbm/hr FUEL FLOW
5747. Btu/lbm LOWER HEATING VALUE
455. Btu/Scf LOWER HEATING VALUE
74854. Scfm EXHAUST FLOW @ 14.7 PSIA & 60F
195493. Acfm ACTUAL EXHAUST FLOW CFm
342170. lbm/hr EXHAUST GAS FLOW
4221.8 deg R ADIA STOICH FLAME TEMP, CHOICE GAS
4682.0 deg R ADIA STOICH FLAME TEMP, SDNG
28.92 --- MOLECULAR WEIGHT OF EXHAUST GAS
16.28 --- AIR/FUEL RATIO

EXHAUST GAS ANALYSIS

ARGON	CO2	H2O	N2	O2	
0.87	5.57	6.50	73.00	14.05	VOLUME PERCENT WET
0.93	5.95	0.00	78.08	15.02	VOLUME PERCENT DRY
4128.	28994.	13865.	241990.	53186.	lbm/hr
0.21	1.46	0.70	12.18	2.68	G/(G FUEL)

- WARNING!!! PLEASE SUBMIT FUEL SUITABILITY -
- INQUIRY TO SAN DIEGO!!!!!!!!!!!!!!!!!!!!!! -

SOLAR TURBINES INCORPORATED
ENGINE PERFORMANCE CODE REV. 3.40
JOB ID:

DATE RUN: 22-Dec-06
RUN BY: Donald C Lyons

--- SUMMARY OF ENGINE EXHAUST ANALYSIS ---
POINT NUMBER 3

GENERAL INPUT SPECIFICATIONS

ENGINE FUEL: CHOICE NATURAL GAS
29.88 in Hg AMBIENT PRESSURE
60.0 percent RELATIVE HUMIDITY
0.0179 --- SP. HUMIDITY (LBM H2O/LBM DRY AIR)

FUEL GAS COMPOSITION (VOLUME PERCENT)

LHV (Btu/Scf) = 454.7 SG = 1.0366 W.I. @60F (Btu/Scf) = 446.6

Methane (CH4) = 49.9999
Carbon Dioxide (CO2) = 49.9999
Sulfur Dioxide (SO2) = 0.0001

*** Wobbe Index of fuel gas is outside of standard gaseous fuel ***
** limits per ES 9-98. Please submit SER for this application. **

*** Landfill and digester gas sources must be disclosed to
Solar Turbines via an SER. Landfill and digester gases
may contain Siloxanes which cause rapid deterioration of
performance and component life. ***

*** Methane content less than 80%. ***
** Please submit SER for this application. **

GENERAL OUTPUT DATA

18132.	lbm/hr	FUEL FLOW
5747.	Btu/lbm	LOWER HEATING VALUE
455.	Btu/Scf	LOWER HEATING VALUE
69041.	Scfm	EXHAUST FLOW @ 14.7 PSIA & 60F
183969.	Acfm	ACTUAL EXHAUST FLOW CFm
313581.	lbm/hr	EXHAUST GAS FLOW
4234.6	deg R	ADIA STOICH FLAME TEMP, CHOICE GAS
4696.5	deg R	ADIA STOICH FLAME TEMP, SDNG
28.73	---	MOLECULAR WEIGHT OF EXHAUST GAS
16.35	---	AIR/FUEL RATIO

EXHAUST GAS ANALYSIS

ARGON	CO2	H2O	N2	O2	
0.86	5.45	8.07	71.78	13.83	VOLUME PERCENT WET
0.93	5.93	0.00	78.08	15.05	VOLUME PERCENT DRY
3744.	26188.	15861.	219468.	48314.	lbm/hr
0.21	1.44	0.87	12.10	2.66	G/(G FUEL)

- WARNING!!! PLEASE SUBMIT FUEL SUITABILITY -
- INQUIRY TO SAN DIEGO!!!!!!!!!!!!!!!!!!!!!! -

SOLAR TURBINES INCORPORATED
ENGINE PERFORMANCE CODE REV. 3.40
JOB ID:

DATE RUN: 22-Dec-06
RUN BY: Donald C Lyons

MARS 100-15000
GSC
59F MATCH
GAS
TMF-2 REV. 3.0

DATA FOR NOMINAL PERFORMANCE

Fuel Type	CHOICE NATURAL GAS			
Elevation	feet	50		
Inlet Loss	in H2O	4.0		
Exhaust Loss	in H2O	4.0		
Engine Inlet Temp.	deg F	45.0	59.0	89.0
Relative Humidity	%	60.0	60.0	60.0
Elevation Loss	kW	20	19	17
Inlet Loss	kW	181	175	159
Exhaust Loss	kW	71	69	65
Gas Generator Speed	RPM	11168	11168	11168
Specified Load*	kW	FULL	FULL	FULL
Net Output Power*	kW	11429	10894	9644
Fuel Flow	mmBtu/hr	118.48	114.14	104.20
Heat Rate*	Btu/kW-hr	10367	10477	10804
Therm Eff*	%	32.915	32.568	31.582
Inlet Air Flow	lbm/hr	334793	323440	296487
Engine Exhaust Flow	lbm/hr	354239	342170	313581
PCD	psiG	254.9	246.1	225.3
Display TS S/W	deg F	1338	1341	1342
Exhaust Temperature	deg F	883	895	923

FUEL GAS COMPOSITION (VOLUME PERCENT)

LHV (Btu/Scf) = 454.7 SG = 1.0366 W.I. @60F (Btu/Scf) = 446.6

Methane (CH4) = 49.9999
Carbon Dioxide (CO2) = 49.9999
Sulfur Dioxide (SO2) = 0.0001

*** Wobbe Index of fuel gas is outside of standard gaseous fuel ***
** limits per ES 9-98. Please submit SER for this application. **

*** Landfill and digester gas sources must be disclosed to
Solar Turbines via an SER. Landfill and digester gases
may contain Siloxanes which cause rapid deterioration of
performance and component life. ***

*** Methane content less than 80%. ***
** Please submit SER for this application. **

*Electric power measured at the generator terminals.

From: Nelson, Deborah [Deborah.Nelson@dep.state.fl.us]

Sent: Friday, February 09, 2007 2:55 PM

To: Pakrasi, Arijit

Subject: RE: Clarification on Modeling Net Emissions for Preliminary Air Quality Analysis to Determine if Significance Level Concentration is Exceeded Okeechobee Landfill Project

Yes. This is OK when modeling the Significant Impact Analysis, determining the Significant Impact Area if multi-source modeling is required. In the write-up, explain this so I don't wonder what happened to the 2 existing flares. Also, make note that these flares will be for emergency use only.

Debbie Nelson

Meteorologist

Air Permitting South

850-921-9537

deborah.nelson@dep.state.fl.us

From: Pakrasi, Arijit [mailto:Arijit.Pakrasi@shawgrp.com]

Sent: Friday, February 09, 2007 11:51 AM

To: Nelson, Deborah

Cc: Blinn, Leah

Subject: Clarification on Modeling Net Emissions for Preliminary Air Quality Analysis to Determine if Significance Level Concentration is Exceeded Okeechobee Landfill Project

Debbie:

We are conducting the preliminary air quality analysis for the project to determine if the ambient concentrations due to *net* emission increases are above the "Significance level". If they are above "significance level" then we will need to do the full impact analysis for Class II PSD increment and NAAQS compliance demonstration. We need a clarification on how we do this for the following case.

To give you a background, the existing emissions are due to 2 existing flares, combusting approximately 6,000 cfm total of landfill gas. The BACT scenario is to replace these flares with 7 LFG turbines @4000 cfm each and a new flare at 3300 cfm, totaling to 31,300 cfm. The existing flares will be on-site as emergency but will not run under this BACT scenario (If they do run due to a outage in the turbines, their emission rates for all criteria pollutants are lower than the turbines on a cfm of LFG basis).

Thus, the net emission change (projected allowable or potential – baseline actual) is calculated as follows:

$$E_{net} = E_{BACT} - E_{existing}$$

Where

- E_{net} = Net emission increase
 E_{BACT} = Potential emissions from 7 turbines and 1 new flare
 $E_{existing}$ = Actual emissions from 2 existing flares

Since the emission increases and decreases are from two different types of sources (turbines vs flares) which are located at two different locations in the facility, we can not just model the net emission increase. So, I was planning to determine the net ambient impact from the net emission increase in the following manner for the preliminary analysis:

- Run AERMOD with 7 new turbines and 1 new flare with their full potential emissions (i.e. at total E_{BACT})
- In the same run, add the existing flares negative emission points with total negative emissions equal to $E_{existing}$

This way, we will have the net ambient impact of the net emissions and we will compare that with the "significance level" concentrations.

Does this seem okay with you?

Thanks

*Arijit Pakrasi, Ph.D., P.E.
Senior Consultant
Shaw Environmental, Inc.
2790 Mosside Boulevard
Monroeville, PA 15146
Ph: 412 858 3921
Fax: 412 372 8968
email: arijit.pakrasi@shawgrp.com*

******Internet Email Confidentiality Footer******

Privileged/Confidential Information may be contained in this message. If you are not the addressee indicated in this message (or responsible for delivery of the message to such person), you may not copy or deliver this message to anyone. In such case, you should destroy this message and notify the sender by reply email. Please advise immediately if you or your employer do not consent to Internet email for messages of this kind. Opinions, conclusions and other information in this message that do not relate to the official business of The Shaw Group Inc. or its subsidiaries shall be understood as neither given nor endorsed by it.

**The Shaw Group Inc.
<http://www.shawgrp.com>**

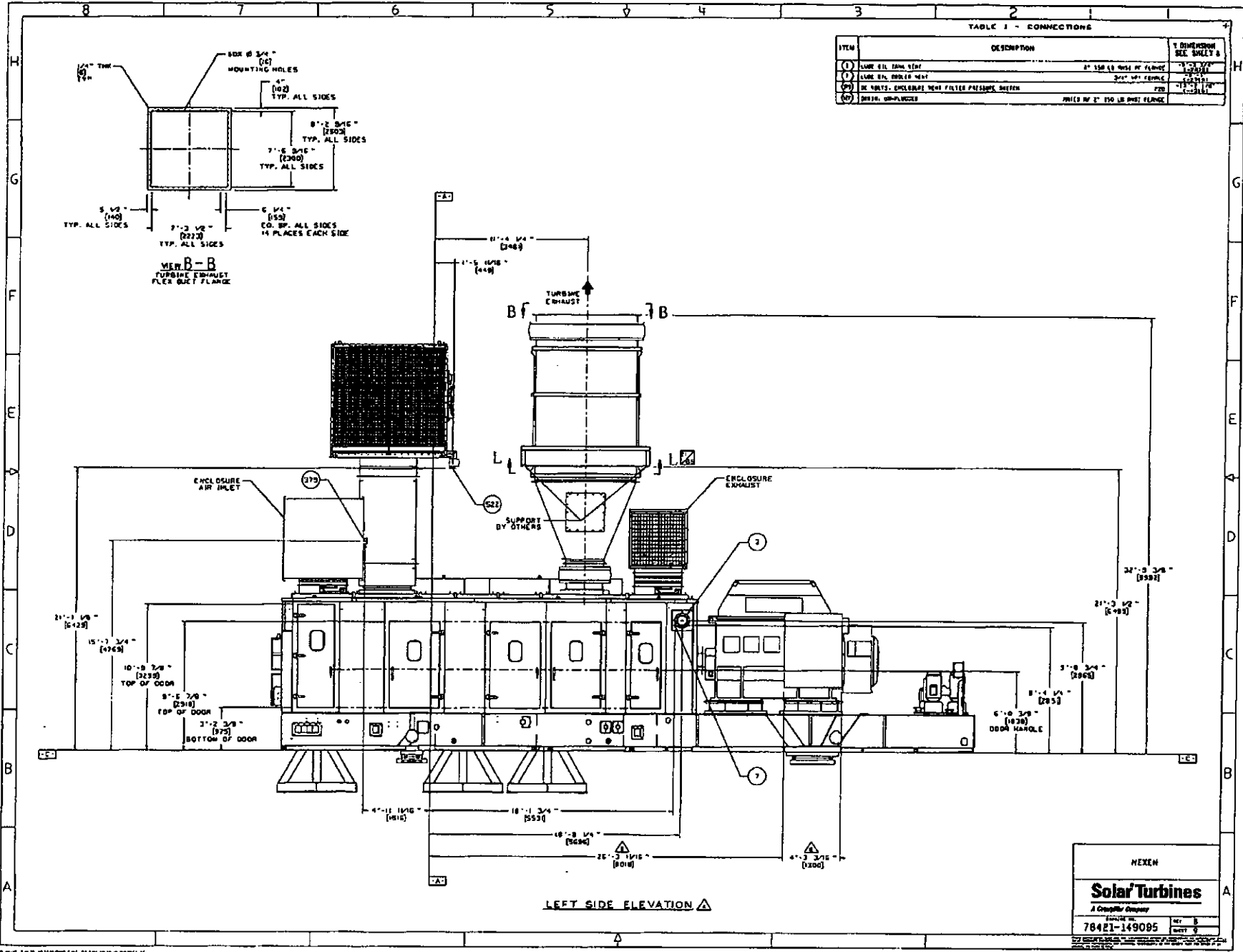

Solar Turbines

A Caterpillar Company

PREDICTED ENGINE PERFORMANCE

Customer Waste Management	
Job ID	
Run By Donald C Lyons	Date Run 24-Oct-06
Engine Performance Code REV. 3.40	Engine Performance Data REV. 3.0

Model MARS 100-15000
Package Type GSC
Match 59F MATCH
Fuel System GAS
Fuel Type CHOICE NATURAL GAS

DATA FOR NOMINAL PERFORMANCE

Elevation	feet	50		
Inlet Loss	in H2O	3.5		
Exhaust Loss	in H2O	3.5		
			1	2
Engine Inlet Temperature	deg F	59.0	59.0	59.0
Relative Humidity	%	60.0	60.0	60.0
Specified Load*	kW	FULL	75.0%	50.0%
Net Output Power*	kW	10924	8193	5462
Fuel Flow	mmBtu/hr	114.28	90.11	68.99
Heat Rate*	Btu/kW-hr	10461	10999	12630
Therm Eff*	%	32.619	31.023	27.015
Engine Exhaust Flow	lbm/hr	342595	306920	263057
Exhaust Temperature	deg F	894	818	778

Fuel Gas Composition (Volume Percent)	Methane (CH4)	50.00
	Carbon Dioxide (CO2)	50.00
	Sulfur Dioxide (SO2)	0.0001

Fuel Gas Properties	LHV (Btu/Scf)	454.7	Specific Gravity	1.0366	Wobbe Index at 60F	446.6
---------------------	---------------	-------	------------------	--------	--------------------	-------

*Electric power measured at the generator terminals.

Notes	
Florida	

Appendix C

Okeechobee
Changes to Off-Property Inventory

SO2

Action	Site Name	EJ Description
1 Deleted - no emission information:	BROWNIE-MAXWELL FUNERAL HOME	HUMAN CREMATOR
2 Deleted - no emission information:	RINKER/MELBOURNE PLANT	FLYASH SILO
3 Deleted - no emission information:	FOUNTAINHEAD FUNERAL HOME	GAS FIRED CREMATOR W/AFTERBURNER CONTROL
4 Deleted - no emission information:	DICTAPHONE CORPORATION	POWDER CURE/DRY-OFF OVEN
5 Deleted - no emission information:	DICTAPHONE CORPORATION	BURN-OFF OVEN
6 Deleted - no emission information:	FAR RESEARCH INC	CHEMICAL SPECIALTY PROCESSES
7 Deleted - no emission information:	R. A. CONNOR PAVING, INC.	AIR CURTAIN INCINERATOR, MODEL T-359
8 Deleted - no emission information:	SPACE COAST CREMATORY	HUMAN CREMATOR
9 Deleted - no emission information:	NORTH CYPRESS RESERVE	Air Curtain Incinerator
10 Deleted - no emission information:	FIBERSTAR, INC.	Citrus Pulp Dryer
11 Deleted - no emission information:	FIBERSTAR, INC.	Citrus Pulp Dryer
12 Deleted - no emission information:	LAKE WALES BRANCH PLANT # 0410	Drum Mix Asphalt Plant - 200 ton per hour
13 Deleted - no emission information:	JAHNA CONCRETE, INC.	CEMENT STORAGE SILO DUST COLLECTOR W/ FILTER VENT
14 Deleted - no emission information:	PHILLIPS STATION	EMERGENCY DIESEL GENERATING UNIT
15 Deleted - no emission information:	HIGHLANDS CREMATORY, INC.	CREMATORY WITH AN AFTERBURNER
16 Deleted - no emission information:	TCSC SEBRING PLANT	VOC Fume Collection System/Thermal Oxidizer
17 Deleted - no emission information:	AVON PARK CITRUS PROCESSING FACILITY	Citrus Feed Dryer & Waste Heat Evaporator
18 Deleted - no emission information:	AIRLITE PROCESSING/VERO BEACH FAC	PERLITE PROCESSING FURNACE #3
19 Deleted - no emission information:	OCEAN SPRAY CRANBERRIES/VERO BEACH	Emergency Generator
20 Deleted - no emission information:	SYNGENTA CROP PROTECTION INC FKA NOVARTIS	Biological waste incinerator/wastewater evaporator
21 Deleted - no emission information:	SOUTHEASTERN RACK COMPANY	BURN OFF OVEN
22 Deleted - no emission information:	SOUTHEASTERN RACK COMPANY	VINYL ROCK COATING PROCESS(CURING OVEN, & SAND BLST)
23 Deleted - no emission information:	LOWTHER CREMATION SERVICES	HUMAN CREMATOR
24 Deleted - no emission information:	ELMO GREER & SONS	Portable Hot Mix Asphalt Plant
25 Deleted - no emission information:	MARTIN POWER PLANT	Two natural gas-fired fuel heaters
26 Deleted - no emission information:	MARTIN POWER PLANT	Diesel Generator for EUs 001 and 002
27 Deleted - no emission information:	LOUIS DREYFUS CITRUS / INDIANTOWN PLANT	30 TMR CITRUS PEEL DRYER #2
28 Deleted - no emission information:	LOUIS DREYFUS CITRUS / INDIANTOWN PLANT	1000 HP Boiler #1
29 Deleted - no emission information:	LOUIS DREYFUS CITRUS / INDIANTOWN PLANT	1000 HP Boiler #2
30 Deleted - no emission information:	LOUIS DREYFUS CITRUS / INDIANTOWN PLANT	1000 HP Boiler #3
31 Deleted - no emission information:	LOUIS DREYFUS CITRUS / INDIANTOWN PLANT	1000 HP Boiler #4
32 Deleted - no emission information:	LOUIS DREYFUS CITRUS / INDIANTOWN PLANT	Citrus Peel Dryer (#1A) / Waste Heat Evaporator
33 Deleted - no emission information:	INDIANTOWN COGENERATION PLANT	Aux Boilers (2)
34 Deleted - no emission information:	RALPH EVINRUDE TEST CENTER	Two fixed engine test cells
35 Deleted - no emission information:	MARTIN FUNERAL HOME AND CREMATORY	Crawford Equipment, Model C1000H Human Crematory
36 Deleted - no emission information:	BUXTON FUNERAL HOME	Incinerator: B&L Cremation Systems, Inc. N20 Series
37 Deleted - no emission information:	BERMAN ROAD LANDFILL	Municipal Solid Waste Landfill
38 Deleted - no emission information:	BERMAN ROAD LANDFILL	3000 SCFM OPEN FLARE, MODEL 1495 (USED AS BACKUP)
39 Deleted - no emission information:	BERMAN ROAD LANDFILL	3000 SCFM ENC FLARE, MODEL 1698 EVAP 3004IM
40 Deleted - no emission information:	TWIN OAKS PET CEMETERY AND CREMATOTORIUM	A B&L System Incinerator (model BLP 500/150)
41 Deleted - no emission information:	TWIN OAKS PET CEMETERY AND CREMATOTORIUM	B&L CREMATION SYSTEMS INC. (MOEEL BLP500/150)INCINERATOR
42 Deleted - no emission information:	OKEECHOBEE CREMATORY, LLC	MATTHEWS MODEL POWER-PAK II IE43PPII
43 Deleted - no emission information:	RELIANT ENERGY OSCEOLA	Pipeline natural gas heaters (2)
44 Deleted - no emission information:	OAK HAMMOCK DISPOSAL FACILITY	PHASE I-CLASS I LANDFILL GAS COLLECTION SYSTEM FLARE 2
45 Deleted - no emission information:	OKEELANTA CORP	Sugar silos Nos. 1, 2, and 3
46 Deleted - no emission information:	OKEELANTA CORP	Railcar sugar unloading receiver No. 1
47 Deleted - no emission information:	OKEELANTA CORP	Railcar sugar unloading receiver No. 2
48 Deleted - no emission information:	ATLANTIC SUGAR MILL	Boiler 4 - 125,000 lb/hr steam rate
49 Deleted - no emission information:	PRATT & WHITNEY AIRCRAFT	CT Test Stands
50 Deleted - no emission information:	RIVIERA POWER PLANT	Emergency diesel generator, and mobile equip. & engines
51 Deleted - no emission information:	CEMEX, INC.	ship unloader with 3 diesel engines and a dust collector
52 Deleted - no emission information:	WEST PALM PLANT	Asphalt cement heater (1.4 mmBTUH) burning distillate oil
53 Deleted - no emission information:	PHYSICAL DISTRIBUTION CENTER & OSF	Wire Reclaim Furnace
54 Deleted - no emission information:	SOLID WASTE AUTHORITY OF PBC/NCRRF	Class I Landfill Flare (3500 scfm)
55 Deleted - no emission information:	VETERANS AFFAIRS MEDICAL CENTER	Fossil Fuel Fired Steam Generators
56 Deleted - no emission information:	VETERANS AFFAIRS MEDICAL CENTER	Electric Power Generators (five)
57 Deleted - no emission information:	COMMUNITY ASPHALT/WEST PALM BEACH PLANT	Asphalt cement heater
58 Deleted - no emission information:	ALL COUNTY FUNERAL HOME AND CREMATORY	HUMAN CREMATION INCINERATOR, IEE CO. #IE43-PPII (150 LB/HR)
59 Deleted - no emission information:	ALL COUNTY FUNERAL HOME AND CREMATORY	Human Cremation Incinerator IE43-PPII
60 Deleted - no emission information:	PALMS WEST CREMATORY (ROYAL PALM BEACH)	Human cremation incinerator
61 Deleted - no emission information:	BELLE GLADE ENERGY CENTER	Other Emissions Units
62 Deleted - no emission information:	EDGLEY CREMATORY, INC.	Two (2) Identical but Independent Cremation Incinerators
63 Deleted - no emission information:	SOUTH FLORIDA MATERIALS CORP.	Two heaters for asphalt
64 Deleted - no emission information:	CITROSUCO NORTH AMERICA, INC.	JOHNSTON 800 HP BOILER
65 Deleted - no emission information:	CITROSUCO NORTH AMERICA, INC.	BOILER NO 3 (2000HP)
66 Deleted - no emission information:	CITROSUCO NORTH AMERICA, INC.	2000 hp Boiler #1A
67 Deleted - no emission information:	CITROSUCO NORTH AMERICA, INC.	Two Emergency Generators
68 Deleted - no emission information:	CITRUS WORLD, INC.	WASTE HEAT BOILER 91.36 MMBTU/HR NATURAL GAS FIRED
69 Deleted - no emission information:	CITRUS WORLD, INC.	NATURAL GAS TURBINE @ 51.1MMBTU/HR (APPROX. 66 DEG. F)

Action	Site Name	EU Description
70 Deleted - no emission information:	CITRUS WORLD, INC.	300 KW Emergency Generator, North Office
71 Deleted - no emission information:	CITRUS WORLD, INC.	400 kw Emergency Generator, Power Generation Facility
72 Deleted - no emission information:	CITRUS WORLD, INC.	400 kw Emergency Generator, Water Reclamation Facility
73 Deleted - no emission information:	LAKE WALES MINE	ROTARY SAND DRYER
74 Deleted - no emission information:	C.C. CALHOUN SITE RF #7	Air Curtain Incinerator
75 Deleted - no emission information:	FT PIERCE UTILIH D KING PWR PLNT	General Purpose Internal Combustion Engines
76 Deleted - no emission information:	TROPICANA PRODUCTS	PEEL DRYER #1 & WASTE HEAT EVAPORATOR #1 WSEPRTR. & WET CYCL
77 Deleted - no emission information:	TROPICANA PRODUCTS	STEAM GENERATOR #1
78 Deleted - no emission information:	TROPICANA PRODUCTS	STEAM GENERATOR #2
79 Deleted - no emission information:	TROPICANA PRODUCTS	PEEL DRYER #2 AND WASTE HEAT EVAPORATOR #2
80 Deleted - no emission information:	TROPICANA PRODUCTS	STEAM PACKAGED BOILER [KEWANEE CLASSIC III MODEL H35-500C]
81 Deleted - no emission information:	ATLANTIC COAST RECYCLING	SECONDARY ALUMINUM SWEAT FURNACE #2
82 Deleted - no emission information:	FPL / ST LUCIE NUCLEAR POWER PLANT	4 MAIN PLANT EMERGENCY DIESEL GENERATORS, each with 2 engine
83 Deleted - no emission information:	FPL / ST LUCIE NUCLEAR POWER PLANT	2 BUILDING EMERGENCY DIESEL GENERATORS
84 Deleted - no emission information:	FPL / ST LUCIE NUCLEAR POWER PLANT	MISCELLANEOUS DIESEL DRIVEN EQUIPMENT
85 Deleted - no emission information:	TREASURE COAST TRACTOR SERVICE	Above Ground Air Curtain Incinerator
86 Deleted - no emission information:	TREASURE COAST ENERGY CENTER	Safe Shutdown Generator with 1000 gallon fuel oil tank.
87 Deleted - no emission information:	TREASURE COAST ENERGY CENTER	Diesel Engine Fire Pump with 500 gallon fuel tank.
88 Deleted - no emission information:	APAC-SOUTHEAST, INC. PORT.ASP. PLNT #450	PORTABLE DRUM MIX ASPHALT PLANT
89 Deleted - no emission information:	APAC-SOUTHEAST, INC. PORT.ASP. PLNT #450	250 TPH Recycle Asphalt Pavement (RAP) Crusher
90 Changed stack ht to 65 m	MARTIN POWER PLANT	Fossil Fuel Fired Steam Generator #1(Acid Rain, Phase II)
91 Changed stack ht to 65 m	MARTIN POWER PLANT	Fossil Fuel Fired Steam Generator #2(Acid Rain, Phase II)
92 Changed stack ht to 65 m	INDIANTOWN COGENERATION PLANT	Pulverized Coal Main Boiler
93 Changed stack ht to 65 m	RIVIERA POWER PLANT	Fossil Fuel Steam Generator, Unit 3 -Phase II Acid Rain Unit
94 Changed stack ht to 65 m	RIVIERA POWER PLANT	Fossil Fuel Steam Generator, Unit 4 -Phase II Acid Rain Unit
95 Deleted - 20D Method	PRATT & WHITNEY AIRCRAFT	Water evaporator (EV-1-MW) wheat input of 0.2 MMBTUH
96 Deleted - 20D Method	PRATT & WHITNEY AIRCRAFT	Boiler (BO-14-E8) wheat input of 7 MMBTUH, propane fired
97 Deleted - 20D Method	SIKORSKY AIRCRAFT CORP. - JUPITER	Paint spray booth (PS-13-SIK) with drying oven
98 Deleted - 20D Method	SIKORSKY AIRCRAFT CORP. - JUPITER	Small boiler (BO-4-SIK), fired by natural gas, 2.93 mmBTU/hr
99 Deleted - 20D Method	FROSTPROOF CITRUS PROCESSING FACILITY	CLEAVER BROOKS BOILER MODEL P-52-E DESIGNATED AS NO. 3
100 Deleted - 20D Method	PRATT & WHITNEY AIRCRAFT	Two furnaces (FU-3-MHT, FU-4-MHT), 6 MMBTUH each
101 Deleted - 20D Method	AVON PARK CITRUS PROCESSING FACILITY	Boiler #1 750 hp Johnston
102 Deleted - 20D Method	AVON PARK CITRUS PROCESSING FACILITY	Boiler #2 750 hp Johnston
103 Deleted - 20D Method	PRATT & WHITNEY AIRCRAFT	Emergency electrical generating facility
104 Deleted - 20D Method	MARTIN NATURAL GAS METER STATION 701	Unit 1 - 10 MMBtu/hour gas-fired natural gas fuel heater
105 Deleted - 20D Method	MARTIN NATURAL GAS METER STATION 701	Unit 2 - 10 MMBtu/hour gas-fired natural gas fuel heater
106 Deleted - 20D Method	MARTIN POWER PLANT	Auxiliary Boiler
107 Deleted - 20D Method	INDIAN RIVER MEMORIAL HOSPITAL	BOILER #1 OIL FIRED 8.40 MMBTU/HR
108 Deleted - 20D Method	HIGHLANDS COUNTY DEPT.OF SOLID WASTE	Landfill Gas Flare
109 Deleted - 20D Method	AVON PARK CITRUS PROCESSING FACILITY	PELLET MILL COOLER
110 Deleted - 20D Method	ANIMAL RESCUE LEAGUE	ANIMAL CREMATION INCINERATOR; CRAWFORD #C-500P; 75 LB/HR
111 Deleted - 20D Method	PALM BCH CO ANIMAL CARE AND CONTROL	ANIMAL CREMATORY
112 Deleted - 20D Method	SDOUTH FLORIDA SHAVINGS CO.	Wood shavings dryer
113 Deleted - 20D Method	HALSLEY-HOBBS FUNERAL HOME	INCINERATOR - HUMAN REMAINS
114 Deleted - 20D Method	PRATT & WHITNEY AIRCRAFT	Miscellaneous air and fuel heaters fired with natural gas
115 Deleted - 20D Method	AIRLITE PROCESSING/VERO BEACH FAC	PERLITE EXPANDER FURNANCE #2
116 Deleted - 20D Method	FOUNTAIN FUNERAL HOME	Crematory Industrial Equipment & Engineering IE43 Power-Pak
117 Deleted - 20D Method	PRATT & WHITNEY AIRCRAFT	2 boilers (BO-1-MBH,BO-2-BMH); 54 MMBTU/hr each, at BH
118 Deleted - 20D Method	PRATT & WHITNEY AIRCRAFT	Miscellaneous diesel engines drving generators, pumps, etc.
119 Deleted - 20D Method	ST LUCIE CO INTL AIRPORT / INCINERATOR	SIMONDS MODEL 751-B INCINERATOR
120 Deleted - 20D Method	SCOBEE-COMBS-BOWDEN FUNERAL HOME	HUMAN CREMATION INCINERATOR, IEE CO, #IE43-PPII (150 LB/HR)
121 Deleted - 20D Method	ANIMAL RESCUE LEAGUE	ANIMAL CREMATION INCINERATOR; CRAWFORD #C-1000S; 250 LB/HR
122 Deleted - 20D Method	PARKWAY ASPHALT (RIVIERA)	Asphalt cement heater fired by No. 2 fuel oil
123 Deleted - 20D Method	LEHIGH ACRES SITE	Above-Ground Refractory-Lined Air Curtain Incinerator - S220
124 Deleted - 20D Method	LAKE WALES BRANCH PLANT # 0410	Relocatable Non-Metallic Mineral Processing Plant
125 Deleted - 20D Method	INDIAN TRAIL IMPROVEMENT DISTRICT - ACI	Air curtain incinerator with compacted limestone pit
126 Deleted - 20D Method	RELIANT ENERGY OSCEOLA	170 MW Simple Cycle Combustion Turbine
127 Deleted - 20D Method	RELIANT ENERGY OSCEOLA	170 MW Simple Cycle Combustion Turbine
128 Deleted - 20D Method	RELIANT ENERGY OSCEOLA	170 MW Simple Cycle Combustion Turbine
129 Deleted - 20D Method	DANIEL P. MAYS/CHURCH ROAD SITE	Portable Refractory-Line Air Curtain Incinerator
130 Deleted - 20D Method	ROYAL PALM MEMORIAL GARDENS, INC.	HUMAN CREMATION INCINERATOR, IEE CO, #IE 43-PPII (100 LB/HR)
131 Deleted - 20D Method	RIVERFRONT GROVES	100 HP STEAM BOILER
132 Deleted - 20D Method	SEAWINDS CREMATORY	CRAWFORD MODEL C-100 HUMAN CREMATORY
133 Deleted - 20D Method	YATES FUNERAL HOME	INDUSTRIAL EQUIPMENT AND ENG MODEL IE43-PPII INCINERATOR
134 Deleted - 20D Method	CITROSUCO NORTH AMERICA, INC.	New 1000 HP Boiler
135 Deleted - 20D Method	TREASURE COAST CREMATORY	HUMAN CREMATION INCINERATOR, MODEL #C-1000
136 Deleted - 20D Method	TREASURE COAST CREMATORY	HUMAN CREMATION INCINERATOR, C-1000
137 Deleted - 20D Method	U.S. SUGAR CLEWISTON MILL AND REFINERY	Boiler 4 - 300,000 lb/hr steam rate (1-hr max.)
138 Deleted - 20D Method	FGTC COMPRESSOR STATION 19	I. C. Engine No. 1901 (2600) NG fired 4 Stroke Lean Burn
139 Deleted - 20D Method	FGTC COMPRESSOR STATION 19	I. C. Engine No. 1902 (2600) NG fired 4 Stroke Lean Burn
140 Deleted - 20D Method	NORTHWOOD FUNERAL HOME	HUMAN CREMATION INCINERATOR, IEE CO, #IE43-PPII (150 LB/HR)
141 Deleted - 20D Method	AYCOCK FUNERAL HOME	IND. EQUIP. & ENGR. MODEL IE43-PPII CREMATOR
142 Deleted - 20D Method	ALICO ROAD ASPHALT PLANT	PORTABLE DRUM MIX ASPHALT PLANT

Action	Site Name	EU Description
143 Deleted - 20D Method	INDIAN RIVER PACKING CO	150 HP PROCESS STEAM BOILER #1
144 Deleted - 20D Method	TRS CONCRETE RECYCLING	Caterpillar diesel engine
145 Deleted - 20D Method	U.S. SUGAR CLEWISTON MILL AND REFINERY	Granular carbon regeneration furnace
146 Deleted - 20D Method	FGTC COMPRESSOR STATION 20	1500 BHP NAT GAS FIRED RECIP IC ENGINE #2001
147 Deleted - 20D Method	FGTC COMPRESSOR STATION 20	1500 BHP NAT GAS FIRED RECIP IC ENGINE #2002
148 Deleted - 20D Method	LAKE PLACID ASPHALT PLANT	Recalable crusher for asphalt, concrete & rock
149 Deleted - 20D Method	SFWMD PUMP STATION G-310	SICE-Six engines driving four pumps and two generators
150 Deleted - 20D Method	APAC-SOUTHEAST, INC. PORT.ASP. PLNT #450	320 HP Diesel Engine and the 100 KW Power generator
151 Deleted - 20D Method	CITROSUCO NORTH AMERICA, INC.	PEEL DRYER NO 2
152 Deleted - 20D Method	SFWMD PUMP STATION S-362	Three - 1303 bhp and two - 639 hp diesel engines.
153 Deleted - 20D Method	CITROSUCO NORTH AMERICA, INC.	PEEL DRYER NO 3
154 Deleted - 20D Method	SFWMD PUMP STATION S-319	Three - 2005 bhp and two - 1210 bhp diesel engines
155 Deleted - 20D Method	FGTC COMPRESSOR STATION 20	2000 BHP NAT GAS FIRED RECIP IC ENGINE #2003
156 Deleted - 20D Method	FGTC COMPRESSOR STATION 19	I. C. Engine No. 1903 (5000) NG fired 2 Stroke Lean
157 Deleted - 20D Method	FGTC COMPRESSOR STATION 20	2400 BHP NAT GAS FIRED RECIP IC ENGINE #2004
158 Deleted - 20D Method	VERO BEACH CITRUS PACKERS	SUPERIOR BOILER-300 HP-BURNING FUEL OIL
159 Deleted - 20D Method	ALICO ROAD ASPHALT PLANT	HEATER
160 Deleted - 20D Method	WEST FELDA TANK BATTERY	Flare with 4 heater/treaters & 3 free water knockout vessels
161 Deleted - 20D Method	FGTC COMPRESSOR STATION 21	COMPRESSOR #2101, 6500 BHP NATURAL GAS FIRED TURBINE
162 Deleted - 20D Method	FGTC COMPRESSOR STATION 21	COMPRESSOR #2102, 6500 BHP NATURAL GAS FIRED TURBINE
163 Deleted - 20D Method	BIOMASS PROCESSING FACILITY - OKEECHOBEE	Kewanee Packaged Scotch Boiler
164 Deleted - 20D Method	FROSTPROOF CITRUS PROCESSING FACILITY	PROCESS STEAM BOILER #2
165 Deleted - 20D Method	FGTC COMPRESSOR STATION 20	4000 BHP I.C. Reciprocating Engine & Assoc. Equip. #2005
166 Deleted - 20D Method	PRATT & WHITNEY AIRCRAFT	Boiler (BO-12-E6) w/heat input of 42 mmBTUH in Test Area E
167 Deleted - 20D Method	WYNNE RANCH SITE (ORANGE AVE.)	Above-ground ACI
168 Deleted - 20D Method	SOUTHERN GARDENS CITRUS PROCESSING CORP.	BOILER #4
169 Deleted - 20D Method	CITRUS WORLD, INC.	GAS TURBINE NO. 2 WWW BOILER
170 Deleted - 20D Method	LEROY E SMITHS SONS	125 HP TITUSVILLE PROCESS STEAM BOILER MODEL #SPO-60
171 Deleted - 20D Method	OCEAN SPRAY CRANBERRIES/VERO BEACH	OIL-FIRED PROCESS STEAM BOILER #1
172 Deleted - 20D Method	ATLANTIC COAST RECYCLING	SECONDARY ALUMINUM SWEAT FURNACE #1
173 Deleted - 20D Method	SFWMD PUMP STATION S-5A	Six - 1600 hp diesel engines powering flood control pumps
174 Deleted - 20D Method	MARTIN POWER PLANT	Diesel Generator(0.718 MW for Units 003-006)
175 Deleted - 20D Method	INDIANTOWN COGENERATION PLANT	(2) Auxiliary Boilers and Temporary Auxiliary Boiler
176 Deleted - 20D Method	MARTIN POWER PLANT	Unit 8B - 170 MW gas turbine with gas-fired HRSG
177 Deleted - 20D Method	OCEAN SPRAY CRANBERRIES/VERO BEACH	500 HP PROCESS STEAM BOILER #3
178 Deleted - 20D Method	BELLE GLADE ENERGY CENTER	176 MW Simple Cycle Unit
179 Deleted - 20D Method	BELLE GLADE ENERGY CENTER	176 MW Simple Cycle Unit
180 Deleted - 20D Method	ATLANTIC SUGAR MILL	Boiler 5 - 115,000 lb/hr steam rate
181 Deleted - 20D Method	OCEAN SPRAY CRANBERRIES/VERO BEACH	CITRUS PEEL DRYER #1
182 Deleted - 20D Method	OCEAN SPRAY CRANBERRIES/VERO BEACH	OIL-FIRED PROCESS STEAM BOILER#2
183 Deleted - 20D Method	FT PIERCE UTIL/H D KING PWR PLNT	37.5 MW Boiler Unit #7 (Phase II Acid Rain Unit)
184 Deleted - 20D Method	FT PIERCE UTIL/H D KING PWR PLNT	37.5 MW Boiler Unit #7 (Phase II Acid Rain Unit)
185 Deleted - 20D Method	FT PIERCE UTIL/H D KING PWR PLNT	16.5 MW Boiler Unit #8
186 Deleted - 20D Method	FT PIERCE UTIL/H D KING PWR PLNT	16.5 MW Boiler Unit #8
187 Deleted - 20D Method	INDIAN RIVER MEMORIAL HOSPITAL	200 HP STEAM BOILER #2
188 Deleted - 20D Method	TOM G. SMITH POWER PLANT	2000 KW DIESEL GENERATOR # 1 PEAKING UNIT
189 Deleted - 20D Method	TOM G. SMITH POWER PLANT	2000 KW DIESEL GENERATOR # 2 PEAKING UNIT
190 Deleted - 20D Method	TOM G. SMITH POWER PLANT	2000 KW DIESEL GENERATOR # 3 PEAKING UNIT
191 Deleted - 20D Method	TOM G. SMITH POWER PLANT	2000 KW DIESEL GENERATOR # 4 PEAKING UNIT
192 Deleted - 20D Method	TOM G. SMITH POWER PLANT	2000 KW DIESEL GENERATOR # 5 PEAKING UNIT
193 Deleted - 20D Method	PHILLIPS STATION	AUXILIARY STEAM BOILER
194 Deleted - 20D Method	U.S. SUGAR CLEWISTON MILL AND REFINERY	DIESEL ELECTRIC GENERATOR #1. GENERAL MOTORS MODEL 16-567-C
195 Deleted - 20D Method	U.S. SUGAR CLEWISTON MILL AND REFINERY	DIESEL GENERATOR #2. GENERAL MOTORS MODEL #16-567-B
196 Deleted - 20D Method	SOLID WASTE AUTHORITY OF PBC/NCRRF	Class III Landfill with Flare
197 Deleted - 20D Method	OCEAN SPRAY CRANBERRIES/VERO BEACH	Citrus Peel Dryer #2
198 Deleted - 20D Method	RELIANT ENERGY OSCEOLA	170 MW Simple Cycle Combustion Turbine
199 Deleted - 20D Method	RELIANT ENERGY OSCEOLA	170 MW Simple Cycle Combustion Turbine
200 Deleted - 20D Method	RELIANT ENERGY OSCEOLA	170 MW Simple Cycle Combustion Turbine
201 Deleted - 20D Method	OKEELANTA CORP	Boiler 16 - 150,000 lb/hr steam rate (gas/oil)
202 Deleted - 20D Method	GEORGIA PACIFIC CORP	BOILER #1
203 Deleted - 20D Method	GEORGIA PACIFIC CORP	BOILER #2
204 Deleted - 20D Method	U.S. SUGAR CORP. BRYANT MILL	DIESEL ELECTRIC GENERATOR GENERAL MOTORS MODEL 16-567-B
205 Deleted - 20D Method	PARKWAY ASPHALT (RIVIERA)	Asphalt rotary drum dryer (400 TPH); counterflow
206 Deleted - 20D Method	CITRUS BELLE	Boiler No. 5
207 Deleted - 20D Method	PHYSICAL DISTRIBUTION CENTER & OSF	12.5 mmBTU/hr boiler #1 (Unit A) burning No.6 fuel oil
208 Deleted - 20D Method	PHYSICAL DISTRIBUTION CENTER & OSF	12.5 mmBTU/hr boiler #2 (Unit B) burning No.6 fuel oil
209 Deleted - 20D Method	U.S. SUGAR CORP. BRYANT MILL	DIESEL ELECTRIC GENERATOR GENERAL MOTORS MODEL 16-567-C
210 Deleted - 20D Method	INTERSIL CORPORATION - PALM BAY	Semiconductor Manufacturing
211 Deleted - 20D Method	FROSTPROOF CITRUS PROCESSING FACILITY	500 HP ERIE CITY PROCESS STEAM BOILER #1
212 Deleted - 20D Method	EAST COAST PAVING - LOXAHATCHEE PLANT	Hot mix asphalt plant (175 TPH)
213 Deleted - 20D Method	SOUTH FLORIDA THERMAL SERVICES, INC.	THERMAL SOIL TREATMENT PLANT WITH AFTERBURNER & BAG-HOUSE
214 Deleted - 20D Method	VERO BEACH PLANT	ASPHALT DRUM-MIX PLANT
215 Deleted - 20D Method	TROPICANA PRODUCTS	New Process Steam Boiler

Action	Site Name	EU Description
216 Deleted - 20D Method	MARTIN POWER PLANT	Unit 8A - 170 MW gas turbine with gas-fired HRSG
217 Deleted - 20D Method	MARTIN POWER PLANT	Unit 8B - 170 MW gas turbine with gas-fired HRSG
218 Deleted - 20D Method	MARTIN POWER PLANT	Unit 8C - 170 MW gas turbine with gas-fired HRSG
219 Deleted - 20D Method	MARTIN POWER PLANT	Unit 8D - 170 MW gas turbine with gas-fired HRSG
220 Deleted - 20D Method	LAKE PLACID ASPHALT PLANT	Asphalt Plant Barber-Greene Drum Mix
221 Deleted - 20D Method	TREASURE COAST LAND CLEARING	Air Burners, LLC, model T-350 ACI
222 Deleted - 20D Method	SOUTHERN GARDENS CITRUS PROCESSING CORP.	BOILER #1 CLEAVER-BROOKS CBW200-800-200-ST 800 HP FIRETUBE
223 Deleted - 20D Method	SOUTHERN GARDENS CITRUS PROCESSING CORP.	BOILER #2 CLEAVER-BROOKS MODEL CBW200-800-200-ST 800 HP
224 Deleted - 20D Method	SOUTHERN GARDENS CITRUS PROCESSING CORP.	BOILER #3, 800 HP FIRETUBE, 36 MMBTU/HR
225 Deleted - 20D Method	WEST PALM PLANT	Double drum dryer (250 TPH)
226 Deleted - 20D Method	NEW PIPER AIRCRAFT	HOT WATER HEATERS/STEAM BOILERS
227 Deleted - 20D Method	FROSTPROOF CITRUS PROCESSING FACILITY	CITRUS PEEL DRYER W/ WASTE HEAT EVAPORATOR
228 Deleted - 20D Method	PRATT & WHITNEY AIRCRAFT	Ten existing jet engine test stands located in Test Area A
229 Deleted - 20D Method	U.S. SUGAR CLEWISTON MILL AND REFINERY	Boiler 4 - 300,000 lb/hr steam rate (1-hr max.)
230 Deleted - 20D Method	GRANT (VALKARIA) PLANT	DRUM MIX ASPHALT PLANT
231 Deleted - 20D Method	ATLANTIC SUGAR MILL	Boiler 3 - 130,000 lb/hr steam rate
232 Deleted - 20D Method	OSCEOLA FARMS	BOILER #3 WITH SCRUBBER
233 Deleted - 20D Method	CITRUS BELLE	Boiler No. 2
234 Deleted - 20D Method	MARTIN POWER PLANT	Unit 8A - 170 MW gas turbine with gas-fired HRSG
235 Deleted - 20D Method	MARTIN POWER PLANT	Unit 8B - 170 MW gas turbine with gas-fired HRSG
236 Deleted - 20D Method	MARTIN POWER PLANT	Unit 8C - 170 MW gas turbine with gas-fired HRSG
237 Deleted - 20D Method	MARTIN POWER PLANT	Unit 8D - 170 MW gas turbine with gas-fired HRSG
238 Deleted - 20D Method	COMMUNITY ASPHALT/WEST PALM BEACH PLANT	Rotary drum mixer (300 TPH) fired by fuel oil
239 Deleted - 20D Method	SOUTHERN GARDENS CITRUS PROCESSING CORP.	CITRUS FEED MILL WITH WASTE HEAT EVAPORATOR
240 Deleted - 20D Method	SOUTHERN GARDENS CITRUS PROCESSING CORP.	Backup Peel Dryer No. 2
241 Deleted - 20D Method	THE PACKERS OF INDIAN RIVER, INC.	STEAM BOILER - 6.27 MMBTU/HR
242 Deleted - 20D Method	OSCEOLA FARMS	BOILER #6 WITH SCRUBBER PSD
243 Deleted - 20D Method	FT PIERCE UTIL/H D KING PWR PLNT	2.75 MW West Diesel #1
244 Deleted - 20D Method	FT PIERCE UTIL/H D KING PWR PLNT	2.75 MW East Diesel #2
245 Deleted - 20D Method	TREASURE COAST ENERGY CENTER	GE PG7241 FA CT (170 MW), HRSG w/ DB, STG (130 MW)
246 Deleted - 20D Method	TREASURE COAST ENERGY CENTER	GE PG7241 FA CT (170 MW), HRSG w/ DB, STG (130 MW)
247 Deleted - 20D Method	TREASURE COAST ENERGY CENTER	GE PG7241 FA CT (170 MW), HRSG w/ DB, STG (130 MW)
248 Deleted - 20D Method	BIOMASS PROCESSING FACILITY - OKEECHOBEE	Packaged Water-Tube Boiler
249 Deleted - 20D Method	SUGAR CANE GROWERS CO-OP	BOILER #3 WITH 1 SCRUBBER AND 1 STACK
250 Deleted - 20D Method	ATLANTIC SUGAR MILL	Boiler 1 - 150,000 lb/hr steam rate
251 Deleted - 20D Method	ATLANTIC SUGAR MILL	Boiler 2 - 150,000 lb/hr steam rate
252 Deleted - 20D Method	OSCEOLA FARMS	BOILER #2 WITH 2 SCRUBBERS AND 2 STACKS
253 Deleted - 20D Method	SOLID WASTE AUTHORITY OF PBC/NCRRF	Municipal Solid Waste Boiler #1
254 Deleted - 20D Method	SOLID WASTE AUTHORITY OF PBC/NCRRF	Municipal Solid Waste Boiler #1
255 Deleted - 20D Method	SOLID WASTE AUTHORITY OF PBC/NCRRF	Municipal Solid waste boiler #2
256 Deleted - 20D Method	SOLID WASTE AUTHORITY OF PBC/NCRRF	Municipal Solid waste boiler #2
257 Deleted - 20D Method	DICKERSON/ASPHALT PLNT#14	275 TPH CONTIN. MIX ASPH.PLANT
258 Deleted - 20D Method	FT PIERCE UTIL/H D KING PWR PLNT	56.1 MW Boiler Unit #8 (Phase II Acid Rain Unit)
259 Deleted - 20D Method	FT PIERCE UTIL/H D KING PWR PLNT	56.1 MW Boiler Unit #8 (Phase II Acid Rain Unit)
260 Deleted - 20D Method	OAK HAMMOCK DISPOSAL FACILITY	PHASE I-CLASS I LANDFILL GAS COLLECTION SYSTEM FLARE 1
261 Deleted - 20D Method	OSCEOLA FARMS	165,000 LB/HR BAGASSE BOILER #5 WITH 2 SCRUBBERS & 2 STACKS
262 Deleted - 20D Method	CITRUS WORLD, INC.	CITRUS PEEL DRYER WITH WASTE-HEAT EVAPORATOR #1
263 Deleted - 20D Method	U.S. SUGAR CLEWISTON MILL AND REFINERY	Boiler 8 - Bagasse boiler rated at 500,000 lb/our steam
264 Deleted - 20D Method	OSCEOLA FARMS	BAGASSE BOILER #4 (UNIT #5), 140,000 LBS/HR STEAM
265 Deleted - 20D Method	CITRUS WORLD, INC.	ERIE CITY KEYSTONE BOILER #1 USING NAT GAS AND #2 OIL
266 Deleted - 20D Method	U.S. SUGAR CLEWISTON MILL AND REFINERY	Boiler 3 - 130,000 lb/hr steam rate (1-hr max.)
267 Deleted - 20D Method	CITY OF VERO BEACH MUNICIPAL UTILITIES	Combined Cycle Gas Turbine Unit 5 (Phase II Acid Rain Unit)
268 Deleted - 20D Method	CITY OF VERO BEACH MUNICIPAL UTILITIES	Combined Cycle Gas Turbine Unit 5 (Phase II Acid Rain Unit)
269 Deleted - 20D Method	CITY OF VERO BEACH MUNICIPAL UTILITIES	Combined Cycle Gas Turbine Unit 5 (Phase II Acid Rain Unit)
270 Deleted - 20D Method	SUGAR CANE GROWERS CO-OP	BOILER #1 WITH 1 SCRUBBER AND 1 STACK
271 Deleted - 20D Method	SUGAR CANE GROWERS CO-OP	BOILER #2 WITH 1 SCRUBBER AND 1 STACK
272 Deleted - 20D Method	OKEELANTA COGENERATION PLANT	Cogeneration Boiler A - 715 MMBtu/hr spreader stoker boiler
273 Deleted - 20D Method	OKEELANTA COGENERATION PLANT	Cogeneration Boiler A - 715 MMBtu/hr spreader stoker boiler
274 Deleted - 20D Method	OKEELANTA COGENERATION PLANT	Cogeneration Boiler A - 715 MMBtu/hr spreader stoker boiler
275 Deleted - 20D Method	OKEELANTA COGENERATION PLANT	Cogeneration Boiler B - 715 MMBtu/hr spreader stoker boiler
276 Deleted - 20D Method	OKEELANTA COGENERATION PLANT	Cogeneration Boiler B - 715 MMBtu/hr spreader stoker boiler
277 Deleted - 20D Method	OKEELANTA COGENERATION PLANT	Cogeneration Boiler B - 715 MMBtu/hr spreader stoker boiler
278 Deleted - 20D Method	OKEELANTA COGENERATION PLANT	Cogeneration Boiler C - 715 MMBtu/hr spreader stoker boiler
279 Deleted - 20D Method	OKEELANTA COGENERATION PLANT	Cogeneration Boiler C - 715 MMBtu/hr spreader stoker boiler
280 Deleted - 20D Method	OKEELANTA COGENERATION PLANT	Cogeneration Boiler C - 715 MMBtu/hr spreader stoker boiler
281 Deleted - 20D Method	U.S. SUGAR CLEWISTON MILL AND REFINERY	Boiler 1 - 255,000 lb/hr steam rate (1-hr max.)
282 Deleted - 20D Method	U.S. SUGAR CLEWISTON MILL AND REFINERY	Boiler 2 - 230,000 lb/hr steam rate (1-hr max.)
283 Deleted - 20D Method	U.S. SUGAR CORP. BRYANT MILL	BOILER #1 WITH SCRUBBER
284 Deleted - 20D Method	U.S. SUGAR CORP. BRYANT MILL	BOILER #2 WITH SCRUBBERS
285 Deleted - 20D Method	U.S. SUGAR CORP. BRYANT MILL	BOILER #3 WITH SCRUBBER
286 Deleted - 20D Method	BELLE GLADE ENERGY CENTER	249.9 MW Combined Cycle Unit
287 Deleted - 20D Method	TOM G. SMITH POWER PLANT	COMBINED CYCLE UNIT (GT-2/S-6)
288 Deleted - 20D Method	SUGAR CANE GROWERS CO-OP	BOILER #8 WITH 2 SCRUBBERS AND 1 STACK

Action	Site Name	EU Description
289 Deleted - 20D Method	CITRUS WORLD, INC.	CITRUS PEEL DRYER WITH WASTE-HEAT EVAPORATOR #2
290 Deleted - 20D Method	CITRUS WORLD, INC.	CITRUS PEEL DRYER WITH WASTE-HEAT EVAPORATOR #3
291 Deleted - 20D Method	SUGAR CANE GROWERS CO-OP	BOILER #6 WITH 2 SCRUBBERS AND 1 STACK
292 Deleted - 20D Method	OKEECHOBEE ASPHALT/ASPHALT PLANT	100 TPH ASPHALT DRUM MIXER WITH VENTURI SCRUBBER
293 Deleted - 20D Method	U.S. SUGAR CORP. BRYANT MILL	BOILER #5 WITH TWO SCRUBBERS
294 Deleted - 20D Method	TOM G. SMITH POWER PLANT	GAS TURBINE # 1
295 Deleted - 20D Method	RANGER / FT. PIERCE	260T/HR (RECYCLE(50%))DRUM MIX(S/N666-88A)
296 Deleted - 20D Method	CITRUS WORLD, INC.	ERIE CITY KEYSTONE BOILER #3 USING NAT GAS AND #2 OIL
297 Deleted - 20D Method	CITRUS WORLD, INC.	ERIE CITY KEYSTONE BOILER #2 USING NAT GAS AND #2 OIL
298 Deleted - 20D Method	U.S. SUGAR CLEWSTON MILL AND REFINERY	Boiler 7 - 385,000 lb/hr steam rate (1-hr max.)
299 Deleted - 20D Method	PRATT & WHITNEY AIRCRAFT	Air compressor/heater (ACHR-2-82)
300 Deleted - 20D Method	SUGAR CANE GROWERS CO-OP	BOILER #4 WITH 2 SCRUBBERS AND 1 STACK
301 Deleted - 20D Method	TOM G. SMITH POWER PLANT	FOSSIL FUEL STEAM GENERATOR #3 (Phase II, Acid Rain Unit)
302 Deleted - 20D Method	TOM G. SMITH POWER PLANT	7.5 MW FOSSIL FUEL STEAM GENERATING UNIT I
303 Deleted - 20D Method	MARTIN POWER PLANT	Combustion Turbine with HRSG (CT 3A)Acid Rain, Phase II)
304 Deleted - 20D Method	MARTIN POWER PLANT	Combustion Turbine with HRSG (CT 3A)Acid Rain, Phase II)
305 Deleted - 20D Method	MARTIN POWER PLANT	Combustion Turbine with HRSG (CT 3B)Acid Rain, Phase II)
306 Deleted - 20D Method	MARTIN POWER PLANT	Combustion Turbine with HRSG (CT 3B)Acid Rain, Phase II)
307 Deleted - 20D Method	MARTIN POWER PLANT	Combustion Turbine with HRSG (CT 4A)Acid Rain, Phase II)
308 Deleted - 20D Method	MARTIN POWER PLANT	Combustion Turbine with HRSG (CT 4A)Acid Rain, Phase II)
309 Deleted - 20D Method	MARTIN POWER PLANT	Combustion Turbine with HRSG (CT 4B)Acid Rain, Phase II)
310 Deleted - 20D Method	MARTIN POWER PLANT	Combustion Turbine with HRSG (CT 4B)Acid Rain, Phase II)
311 Deleted - Modeled in Site Inventory	BERMAN ROAD LANDFILL	3000 SCFM ENC FLARE, MODEL 1776 EVAP 3016
312 Deleted - Duplicate Entry	FT PIERCE UTILH D KING PWR PLNT	23.4 MW CCGT with 8.2 MW HRSG Unit # 8
313 Deleted - Duplicate Entry	CITY OF VERO BEACH MUNICIPAL UTILITIES	Fossil Fuel Steam Generator Unit 4 (Phase II Acid Rain Unit)

Middle of Sources 530167.4 (m) East 3023733 (m) North
 AOI (km)
 AOI + 50km 50000 (m)

FACILITY ID	PSD Source?	OWNER/COMPANY NAME	SITE NAME	STATUS	ZONE	NORTH (km)	EAST (km)
0510003	no	CITY OF VERO BEACH	CITY OF VERO BEACH MUNICIPAL UTILITIES	A	17	3056.5	561.4
0510003	yes	TAMPA ELECTRIC COMPANY	PHILLIPS STATION	A	17	3035.4	464.3
1110060	yes	TAMPA ELECTRIC COMPANY	PHILLIPS STATION	A	17	3035.4	464.3
1110060	no	FLORIDA POWER CORPORATION D/B/A PROGRESS	AVON PARK	A	17	3050.5	451.4
1110060	no	FLORIDA POWER CORPORATION D/B/A PROGRESS	AVON PARK	A	17	3050.5	451.4
1110107	yes	FT PIERCE UTILITIES AUTHORITY	FT PIERCE UTIL/H D KING PWR PLNT	A	17	3036.35	566.12
1110117	no	CITY OF VERO BEACH	CITY OF VERO BEACH MUNICIPAL UTILITIES	A	17	3056.5	561.4
1110121	no	CITY OF LAKE WORTH UTILITIES	TOM G. SMITH POWER PLANT	A	17	2943.7	592.8
1110121	yes	CITY OF VERO BEACH	CITY OF VERO BEACH MUNICIPAL UTILITIES	A	17	3056.5	561.4
7770073	yes	INDIANTOWN COGENERATION, L.P.	INDIANTOWN COGENERATION PLANT	A	17	2990.7	547.65
7775058	no	CITY OF VERO BEACH	CITY OF VERO BEACH MUNICIPAL UTILITIES	A	17	3056.5	561.4
7775172	no	FLORIDA POWER & LIGHT (PRV)	RIVIERA POWER PLANT	A	17	2960.62	593.27
7775172	no	FLORIDA POWER & LIGHT (PRV)	RIVIERA POWER PLANT	A	17	2960.62	593.27
7775215	yes	FLORIDA POWER & LIGHT (PMR)	MARTIN POWER PLANT	A	17	2992.65	542.68
7775253	yes	FLORIDA POWER & LIGHT (PMR)	MARTIN POWER PLANT	A	17	2992.65	542.68

EU ID	EU DESCRIPTION	EU STATUS	STACK HT (ft)	DIAM (ft)	EXIT TEMP (F)	ACFM	VEL (ft/s)	POLLUTANT
1	Fossil Fuel Steam Generator Unit No.1	A	200	3.5	289	80883	105.5	SO2
1	19.535 MW SLOW SPEED DIESEL GENERATING UNIT 1	A	150	6	335	134500	79	SO2
2	19.535 MW SLOW SPEED DIESEL GENERATING UNIT 2	A	150	6	350	135500	79	SO2
3	Gas Turbine Peaking Unit No. 1	A	55	10	850	2000000	424	SO2
4	Gas Turbine Peaking Unit No. 2	A	55	10	850	2000000	424.4	SO2
3	23.4 MW CCGT with 8.2 MW HRSG Unit # 9	A	68	11.2	426	353500	59.8	SO2
2	Fossil Fuel Steam Generator Unit No.2	A	200	3.5	347	79217	137.2	SO2
10	FOSSIL FUEL STEAM GENERATOR #4 (Phase II, Acid Rain Unit)	A	115	7.5	293	147839	55.8	SO2
4	Fossil Fuel Steam Generator Unit 4 (Phase II Acid Rain Unit)	A	200	7	283	179475	77.7	SO2
1	Pulverized Coal Main Boiler	A	213.25	16	140	1123700	93.2	SO2
3	Fossil Fuel Steam Generator Unit 3 (Phase II Acid Rain Unit)	A	200	6	342	116375	68.6	SO2
3	Fossil Fuel Steam Generator, Unit 3 -Phase II Acid Rain Unit	A	213.25	16	263	1063401	88.2	SO2
4	Fossil Fuel Steam Generator, Unit 4 -Phase II Acid Rain Unit	A	213.25	16	263	1052648	87.3	SO2
1	Fossil Fuel Fired Steam Generator #1(Acid Rain, Phase II)	A	213.25	36	338	2634519	43.1	SO2
2	Fossil Fuel Fired Steam Generator #2(Acid Rain, Phase II)	A	213.25	36	338	2634519	43.1	SO2

Potential (lb/hr)	Potential (tpy)	Allowable (lb/hr)	Allowable (tpy)	Comments
230.2	1008	230.2	1008	Based on BACT determination (Rule 62-296.406(3))
459.29	2011.5	459.29	2011.5	
459.29	2011.5	459.29	2011.5	
577	2527	577	2527	Basis for allowable emission is AO 28-202500. Sulfur content limit is not federally enforceable.
577	2527	577	2527	Basis for allowable emission is AO 28-202500. Sulfur content limit is not federally enforceable.
319.51	1385.62	319.51	1395.62	While burning natural gas. RN: see calcns -em un rpts.
399.5	1750	399.5	1750	Fuel sulfur limited by BACT.
1072	4695	1072	4695	% S limited to 2.25% by PPSC PA 74-05.
548	2400	548	2400	Limit is for liquid fuel. Cofiring with gas is allowed by rule and permit. 340 nanograms/joule heat input
582	2549	582	2549	Basis for allowable emissions: PSD-FL-168. Emission limit based on 24 hr daily block average (midnight to midnight).
1127.5	4938	1127.5	4938	Method 6 or 6C if DEP believes that exceedences of SO2 emissions limiting standard are occurring
8387.5	36737.25	8387.5	36737.25	Equivalent allowable emissions are given for liquid fuel firing.
8387.5	36737.25	8387.5	36737.25	Equivalent allowable emissions are given for liquid fuel firing.
6920	30309.6	6920	30309	Lbs/hr is for 100% oil firing.
6920	30309.6	6920	30309	Lbs/hr is for 100% oil firing.

Distance (m)	20D Tons/Distance	Include in Inventory?
45267.5556	22.26760394	Yes
66892.6997	30.07054595	
66892.6997	30.07054595	Yes
83191.199	30.37580934	Yes
83191.199	30.37580934	Yes
38102.2064	36.62832498	Yes
45267.5556	38.65903462	Yes
101627.377	46.19818161	Yes
45267.5556	53.01810463	Yes
37374.0604	68.20238347	Yes
45267.5556	109.0847503	Yes
89247.907	411.6315021	Yes
89247.907	411.6315021	Yes
33506.9851	904.55766	Yes
33506.9851	904.55766	Yes

ANNUAL

Middle of Sources : S20430.1 (m) East
AOI : 7.2 (km)
AOI = 50km 57200 (m)

3023855 (m) North

PSD Source#	NORTH (m)	EAST (m)	EU ID	EU DESCRIPTION	EU STATUS	STACK HT (m)	DIAM (m)	EXIT TEMP (F)	VEL (m/s)
99	3026.1	581.4	1	Fossil Fuel Steam Generator Unit No. 1	A	200	2.8	298	106.5
99	3026.4	464.3	2	18.333 MW SLOW SPEED DIESEL GENERATING UNIT 1	A	150	8	333	78
99	3026.4	464.3	3	18.333 MW SLOW SPEED DIESEL GENERATING UNIT 2	A	150	8	336	78
99	3026.5	451.4	4	Gas Turbine Peaking Unit No. 1	A	55	10	858	424
99	3026.5	451.4	5	Gas Turbine Peaking Unit No. 2	A	55	10	858	424
99	3026.15	581.13	6	23.4 MW CCGT Unit # 2 HRSG Unit # 9	A	58	11.2	426	98.8
99	3026.1	581.4	7	Fossil Fuel Steam Generator Unit No. 2	A	200	2.8	347	127.2
99	2943.7	592.8	8	FOSSIL FUEL STEAM GENERATOR #4 (Phase II, Acid Rain Unit)	A	111	7.5	253	53.8
99	3026.1	581.4	9	Fossil Fuel Steam Generator Unit 4 (Phase II, Acid Rain Unit)	A	300	7	283	77.2
99	2990.7	547.53	10	Pulverized Coal Main Boiler	A	213.25	16	148	53.2
99	3026.1	581.4	11	Fossil Fuel Steam Generator Unit 3 (Phase II, Acid Rain Unit)	A	200	8	342	68.8
99	2990.02	581.27	12	Fossil Fuel Steam Generator, Unit 3, Phase II, Acid Rain Unit	A	213.25	16	263	89.2
99	2943.42	593.27	13	Fossil Fuel Steam Generator, Unit 4, Phase II, Acid Rain Unit	A	213.25	16	263	87.3
99	2993.85	542.88	14	Fossil Fuel Fired Steam Generator #1(Acid Rain, Phase II)	A	213.25	36	338	43.1
99	2993.85	542.88	15	Fossil Fuel Fired Steam Generator #2(Acid Rain, Phase II)	A	213.25	36	338	43.1

NAAQ5 Sources

Scenario 1 - NAAQS - Annual

Source ID	Source Description	Easting (X) (m)	Northing (Y) (m)	Base Elevation (m)	Stack Height (ft)	Temperature (°F)	Exit Velocity (ft/s)	Stack Diameter (ft)	SO2 (lb/hr)
1	Fossil Fuel Steam Generator Unit No. 1	561400	3026500	80.08	200	283	105.5	2.5	210.2
8	23.4 MW CCGT with 8.2 MW HRSG Unit # 9	561120	3026350	20.73	68	426	59.8	11.2	319.51
7	Fossil Fuel Steam Generator Unit No. 2	561400	3026500	80.08	200	347	127.2	3.5	399.5
9	Fossil Fuel Steam Generator Unit 4 (Phase II, Acid Rain Unit)	561400	3026500	80.08	200	283	77.7	7	548
10	Pulverized Coal Main Boiler	547850	2990700	65.00	213.25	140	93.2	16	582
11	Fossil Fuel Steam Generator Unit 3 (Phase II, Acid Rain Unit)	561400	3026500	80.08	200	342	68.8	8	1127.5
14	Fossil Fuel Fired Steam Generator #1(Acid Rain, Phase II)	542880	2992850	65.00	213.25	338	43.1	36	6820
15	Fossil Fuel Fired Steam Generator #2(Acid Rain, Phase II)	542880	2992850	65.00	213.25	338	43.1	36	6820

Scenario 1 - PSD - Annual

Source ID	Source Description	Easting (X) (m)	Northing (Y) (m)	Base Elevation (m)	Stack Height (ft)	Temperature (°F)	Exit Velocity (ft/s)	Stack Diameter (ft)	SO2 (lb/hr)
8	23.4 MW CCGT with 8.2 MW HRSG Unit # 9	561120	3026350	20.73	68	426	59.8	11.2	319.51
9	Fossil Fuel Steam Generator Unit 4 (Phase II, Acid Rain Unit)	561400	3026500	80.08	200	283	77.7	7	548
10	Pulverized Coal Main Boiler	547850	2990700	65.00	213.25	140	93.2	16	582
14	Fossil Fuel Fired Steam Generator #1(Acid Rain, Phase II)	542880	2992850	65.00	213.25	338	43.1	36	6820
15	Fossil Fuel Fired Steam Generator #2(Acid Rain, Phase II)	542880	2992850	65.00	213.25	338	43.1	36	6820

Potential (N/W)	Potential (P/y)	Admissible (N/W)	Admissible (P/y)	Distance (m)	200 Time/Distance	Include in Inventory?
250.2	1008	250.2	1008	44986.0545	22.40196415	Yes
458.29	2011.5	458.29	2011.5	87133.2561	29.86278559	
458.29	2011.5	458.29	2011.5	87133.2561	29.86278559	
577	2527	577	2527	83403.7584	30.29639479	
577	2527	577	2527	83403.7584	30.29639479	
319.51	1299.62	319.51	1299.62	37811.1078	35.91031787	Yes
296.5	1160	296.5	1160	44998.0545	38.89229688	Yes
1042	4898	1042	4898	101580.102	48.22878399	
548	2400	548	2400	44998.0545	53.33800989	Yes
542	2549	542	2549	37356.7428	68.23004724	Yes
1127.5	4808	1127.5	4808	44998.0545	109.7429554	Yes
8387.5	36732.25	8387.5	36732.25	89148.7399	412.0588371	
8387.5	36732.25	8387.5	36732.25	89148.7399	412.0588371	
8930	38308.8	8930	38308.8	33522.2103	904.1488242	Yes
8930	38308.8	8930	38308.8	33522.2103	904.1488242	Yes

3-hr

Middle of Sources : 300430.1 (m) East
 AOI : 12.4 (km)
 AOI + 50km : 62400 (m)

302385 (m) North

PSD Source#	NORTH (m)	EAST (m)	EU ID	EU DESCRIPTION	EU STATUS	STACK HT (m)	DIAM (m)	EXIT TEMP (F)	VEL (m/s)
no	3058.5	561.4	1	Fossil Fuel Steam Generator Unit No.1	A	200	3.5	289	195.3
yes	3035.4	464.2	2	19.531 MW SLOW SPEED DIESEL GENERATING UNIT 1	A	156	6	335	79
yes	3035.4	464.2	3	19.531 MW SLOW SPEED DIESEL GENERATING UNIT 2	A	156	6	350	79
no	3090.8	451.4	4	Gas Turbine Peaking Unit No. 1	A	55	10	656	424
no	3090.8	451.4	5	Gas Turbine Peaking Unit No. 2	A	55	10	650	424.4
yes	3038.25	568.17	6	23.4 MW CCGT with 8.2 MW HRSG Unit # 9	A	66	11.2	425	39.6
no	3096.5	561.4	7	Fossil Fuel Steam Generator Unit No.3	A	200	3.5	347	137.2
no	2943.7	562.8	8	Fossil Fuel Steam Generator Unit 4 (Phase II Acid Rain Unit)	A	115	7.5	293	53.6
yes	3054.5	561.4	9	Fossil Fuel Steam Generator Unit 4 (Phase II Acid Rain Unit)	A	200	7	283	77.7
yes	2990.7	547.65	10	Pulverized Coal Man Boiler	A	213.25	16	348	80.2
no	3054.5	561.4	11	Fossil Fuel Steam Generator Unit 3 (Phase II Acid Rain Unit)	A	200	6	342	66.6
no	2990.62	563.27	12	Fossil Fuel Steam Generator Unit 3 (Phase II Acid Rain Unit)	A	213.25	16	363	86.2
no	2988.62	563.27	13	Fossil Fuel Steam Generator Unit 4 (Phase II Acid Rain Unit)	A	213.25	16	363	87.3
yes	2982.85	542.84	14	Fossil Fuel Steam Generator #1(Acid Rain, Phase I)	A	213.25	36	338	43.1
yes	2982.85	542.84	15	Fossil Fuel Steam Generator #2(Acid Rain, Phase I)	A	213.25	36	338	43.1

NAAQ5 Sources

Scenario 1 - NAAQS - 3-hr

Source ID	Source Description	Eastng (X) (m)	Northng (Y) (m)	Base Elevation (m)	Stack Height (ft)	Temperature (°F)	Exit Velocity (ft/s)	Stack Diameter (ft)	SO2 (lb/hr)
1	Fossil Fuel Steam Generator Unit No.1	561400	3058500	80.08	200	289	105.5	3.5	230.2
6	23.4 MW CCGT with 8.2 MW HRSG Unit # 9	566120	3038350	20.73	66	426	56.8	11.2	319.51
7	Fossil Fuel Steam Generator Unit No.2	561400	3058500	80.08	200	347	137.2	3.5	399.5
9	Fossil Fuel Steam Generator Unit 4 (Phase II Acid Rain Unit)	561400	3058500	80.08	200	283	77.7	7	548
10	Pulverized Coal Man Boiler	547650	2990700	85.00	213.25	140	93.2	16	562
11	Fossil Fuel Steam Generator Unit 3 (Phase II Acid Rain Unit)	561400	3058500	80.08	200	342	66.6	6	1127.5
14	Fossil Fuel Fired Steam Generator #1(Acid Rain, Phase I)	542860	2982850	85.00	213.25	338	43.1	36	6920
15	Fossil Fuel Fired Steam Generator #2(Acid Rain, Phase I)	542860	2982850	85.00	213.25	338	43.1	36	6920

Scenario 1 - PSD - 3-hr

Source ID	Source Description	Eastng (X) (m)	Northng (Y) (m)	Base Elevation (m)	Stack Height (ft)	Temperature (°F)	Exit Velocity (ft/s)	Stack Diameter (ft)	SO2 (lb/hr)
6	23.4 MW CCGT with 8.2 MW HRSG Unit # 9	566120	3038350	20.73	66	426	56.8	11.2	319.51
9	Fossil Fuel Steam Generator Unit 4 (Phase II Acid Rain Unit)	561400	3058500	80.08	200	283	77.7	7	548
10	Pulverized Coal Man Boiler	547650	2990700	85.00	213.25	140	93.2	16	562
14	Fossil Fuel Fired Steam Generator #1(Acid Rain, Phase I)	542860	2982850	85.00	213.25	338	43.1	36	6920
15	Fossil Fuel Fired Steam Generator #2(Acid Rain, Phase I)	542860	2982850	85.00	213.25	338	43.1	36	6920

Personnel (h/yr)	Material (py)	Allowable (h/yr)	Allowable (py)	Distance (m)	200 Total Distance	In late on Inventory?
220.2	9006	230.2	9006	44906.0645	22.40190415	Yes
458.28	2011.8	458.28	2011.8	07133.2551	29.06279559	
458.28	2011.8	458.28	2011.8	07133.2551	29.06279559	
577	2529	577	2529	83403.7504	30.29826478	
577	2529	577	2529	83403.7504	30.29826478	
319.51	1395.62	319.51	1395.62	37811.1078	26.91031767	Yes
399.5	1750	399.5	1750	44906.0545	38.89228888	Yes
1872	4896	1872	4896	101580.102	46.22878390	
548	2400	548	2400	44906.0545	53.33800989	Yes
542	2549	542	2549	37358.7428	88.25034724	Yes
1127.5	4838	1127.5	4838	44906.0645	109.7423554	Yes
6387.5	24737.25	6387.5	24737.25	89148.7388	412.0968371	
6387.5	24737.25	6387.5	24737.25	89148.7388	412.0968371	
8820	30888.8	8820	30309	33522.2100	604.1488242	Yes
8820	30309.8	8820	30309	33522.2100	604.1488242	Yes

24-hr

Middle of Sources 530433.1 (m) East
AOI 19.6 (km)
AOI = 50km 69600 (m)

3022855 (m) North

PSD Source#	NORTH (m)	EAST (m)	EU ID	EU DESCRIPTION	EU STATUS	STACK HT (m)	DASH (m)	EMT TEMP (F)	VEL (ft/s)
700	3036.1	561.4	1	Fossil Fuel Steam Generator Unit No 1	A	200	3.5	299	106.3
700	3036.4	464.2	2	19.535 MW SLOW SPEED DIESEL GENERATING UNIT 1	A	150	6	325	78
700	3031.4	464.2	3	19.535 MW SLOW SPEED DIESEL GENERATING UNIT 2	A	150	6	350	78
700	3030.5	451.4	4	Gas Turbine Peaking Unit No 1	A	55	10	650	421
700	3030.5	451.4	5	Gas Turbine Peaking Unit No 2	A	55	10	650	424.4
700	3056.25	561.12	6	23.4 MW CCGT with 2.2 MW HRSG Unit # 9	A	68	11.2	426	59.9
700	3056.5	561.4	7	Fossil Fuel Steam Generator Unit No 2	A	200	3.5	347	132.3
700	2942.7	562.8	8	FOSSIL FUEL STEAM GENERATOR #4 (Phase II Acid Rain Unit)	A	115	7.5	283	35.8
700	3056.5	561.4	9	Fossil Fuel Steam Generator Unit 4 (Phase II Acid Rain Unit)	A	200	7	253	77.7
700	2990.7	547.65	10	Pulverized Coal Main Boiler	A	213.25	16	140	93.2
700	3056.5	561.4	11	Fossil Fuel Steam Generator Unit 3 (Phase II Acid Rain Unit)	A	200	6	342	84.6
700	2990.42	562.27	12	Fossil Fuel Steam Generator Unit 3 (Phase II Acid Rain Unit)	A	213.25	16	283	84.2
700	2990.42	562.27	13	Fossil Fuel Steam Generator Unit 4 (Phase II Acid Rain Unit)	A	213.25	16	283	87.3
700	2997.65	542.86	14	Fossil Fuel Fired Steam Generator #1(Acid Rain, Phase II)	A	213.25	36	338	43.1
700	2997.65	542.86	15	Fossil Fuel Fired Steam Generator #2(Acid Rain, Phase II)	A	213.25	36	338	43.1

NAAQS Sources

Scenario 1 - NAAQS - 24-hr

Source ID	Source Description	Eastng (X) (m)	Northng (Y) (m)	Base Elevation (m)	Stack Height (ft)	Temperature (°F)	ExR Velocity (ft/s)	Stack Diameter (ft)	SO2 (lb/hr)
1	Fossil Fuel Steam Generator Unit No 1	561400	3056500	60.98	200	289	105.5	3.5	230.2
2	19.535 MW SLOW SPEED DIESEL GENERATING UNIT 1	464300	3035400	61.98	150	335	78	6	459.29
3	19.535 MW SLOW SPEED DIESEL GENERATING UNIT 2	464300	3035400	62.96	150	350	78	6	459.28
6	23.4 MW CCGT with 2.2 MW HRSG Unit # 9	566120	3036350	20.73	68	426	59.6	11.2	319.51
7	Fossil Fuel Steam Generator Unit No. 2	561400	3056500	60.98	200	347	137.2	3.5	399.5
9	Fossil Fuel Steam Generator Unit 4 (Phase II Acid Rain Unit)	561400	3056500	60.98	200	283	77.7	7	64.6
10	Pulverized Coal Main Boiler	547650	2890700	65.00	213.25	140	93.2	16	582
11	Fossil Fuel Steam Generator Unit 3 (Phase II Acid Rain Unit)	561400	3056500	60.98	200	342	66.6	6	1127.6
14	Fossil Fuel Fired Steam Generator #1(Acid Rain, Phase II)	542660	2962650	65.00	213.25	338	43.1	36	6920
15	Fossil Fuel Fired Steam Generator #2(Acid Rain, Phase II)	542660	2962650	65.00	213.25	338	43.1	36	6920

Scenario 1 - PSD - 24-hr

Source ID	Source Description	Eastng (X) (m)	Northng (Y) (m)	Base Elevation (m)	Stack Height (ft)	Temperature (°F)	ExR Velocity (ft/s)	Stack Diameter (ft)	SO2 (lb/hr)
2	19.535 MW SLOW SPEED DIESEL GENERATING UNIT 1	464300	3035400	61.98	150	335	78	6	459.29
3	19.535 MW SLOW SPEED DIESEL GENERATING UNIT 2	464300	3035400	62.96	150	350	78	6	459.28
6	23.4 MW CCGT with 2.2 MW HRSG Unit # 9	566120	3036350	20.73	68	426	59.6	11.2	319.51
9	Fossil Fuel Steam Generator Unit 4 (Phase II Acid Rain Unit)	561400	3056500	60.98	200	283	77.7	7	64.6
10	Pulverized Coal Main Boiler	547650	2990700	65.00	213.25	140	93.2	16	582
14	Fossil Fuel Fired Steam Generator #1(Acid Rain, Phase II)	542660	2962650	65.00	213.25	338	43.1	36	6920
15	Fossil Fuel Fired Steam Generator #2(Acid Rain, Phase II)	542660	2962650	65.00	213.25	338	43.1	36	6920

Potential (kWh)	Potential (kw)	Allowable (kWh)	Allowable (kw)	Distance (m)	200 Term Distance	Include in Inventory?
739.2	1088	238.2	9000	44998 0545	22 40195415	Yes
479.29	3811.5	459.29	3011.5	87133 2551	29 96278558	Yes
498.28	3811.5	459.29	3011.5	87133 2551	29 96279658	Yes
577	2527	577	7429	83403 7584	30 29639478	
577	2527	577	7429	83403 7584	30 29639479	
318.51	1389.62	318.51	1389.62	37811.1078	36 91031787	Yes
368.5	1710	368.5	1710	44998 0545	38 89278888	Yes
1072	4885	1072	4885	101660 102	48 22878399	
546	2400	546	2400	44998 0545	53 33800989	Yes
542	2549	542	2549	37358 7429	68 23034726	Yes
1137.5	4328	1137.5	4328	44998 0545	108 7429554	Yes
8387.5	36737.25	8387.5	36737.25	89148.7399	412 0988371	
8387.5	36737.25	8387.5	36737.25	89148.7399	412 0988371	
6179	30309.8	6179	30309	33522 2103	904 1468242	Yes
6120	30309.8	6120	30309	33522 2103	904 1468242	Yes

ANNUAL

Middle of Sources 530451.8 (m) East
 AOI 1.7 (km)
 AOI + 50km 51700 (m)

3023781 (m) North

PSD Source?	NORTH (m)	EAST (km)	EU ID	EU DESCRIPTION	EU STATUS	STACK HT (ft)	DIAM (ft)	EXIT TEMP (F)	VEL (ft/s)
no	3050.5	561.4	1	Fossil Fuel Steam Generator Unit No.1	A	200	3.5	289	105.5
yes	3035.4	464.3	2	18.535 MW SLOW SPEED DIESEL GENERATING UNIT 1	A	150	6	335	79
yes	3035.4	464.3	3	18.535 MW SLOW SPEED DIESEL GENERATING UNIT 2	A	150	6	350	79
no	3050.5	451.4	4	Gas Turbine Peaking Unit No. 1	A	55	10	650	424
no	3050.5	451.4	5	Gas Turbine Peaking Unit No. 2	A	55	10	650	424.4
yes	3036.35	568.12	6	23.4 MW CCGT with 8.2 MW HRSG Unit # 9	A	68	11.2	426	59.8
no	3056.5	561.4	7	Fossil Fuel Steam Generator Unit No.2	A	200	3.5	347	137.2
no	2943.7	592.8	8	FOSSIL FUEL STEAM GENERATOR #4 (Phase II, Acid Rain Unit)	A	115	7.5	293	55.8
yes	3056.5	561.4	9	Fossil Fuel Steam Generator Unit 4 (Phase II Acid Rain Unit)	A	200	7	283	77.7
yes	2990.7	547.65	10	Pulverized Coal Main Boiler	A	213.25	16	140	93.2
no	3056.5	561.4	11	Fossil Fuel Steam Generator Unit 3 (Phase II Acid Rain Unit)	A	200	6	342	68.6
no	2890.62	593.27	12	Fossil Fuel Steam Generator, Unit 3 -Phase II Acid Rain Unit	A	213.25	16	263	66.2
no	2990.62	593.27	13	Fossil Fuel Steam Generator, Unit 4 -Phase II Acid Rain Unit	A	213.25	18	263	67.3
yes	2992.65	542.68	14	Fossil Fuel Fired Steam Generator #1(Acid Rain, Phase II)	A	213.25	36	338	43.1
yes	2992.65	542.68	15	Fossil Fuel Fired Steam Generator #2(Acid Rain, Phase II)	A	213.25	36	338	43.1

NAAQS Sources

Scenario 2 - NAAQS - Annual

Source ID	Source Description	Easting (X) (m)	Northing (Y) (m)	Base Elevation (m)	Stack Height (ft)	Temperature (°F)	Exit Velocity (fps)	Stack Diameter (ft)	SO2 (lb/hr)
1	Fossil Fuel Steam Generator Unit No.1	561400	3058500	60.96	200	289	105.5	3.5	230.2
6	23.4 MW CCGT with 8.2 MW HRSG Unit # 9	566120	3036350	20.73	68	426	59.8	11.2	319.51
7	Fossil Fuel Steam Generator Unit No.2	561400	3056500	60.96	200	347	137.2	3.5	399.5
9	Fossil Fuel Steam Generator Unit 4 (Phase II Acid Rain Unit)	561400	3056500	60.96	200	283	77.7	7	548
10	Pulverized Coal Main Boiler	547650	2990700	65.00	213.25	140	93.2	16	582
11	Fossil Fuel Steam Generator Unit 3 (Phase II Acid Rain Unit)	561400	3056500	60.96	200	342	68.6	6	1127.5
14	Fossil Fuel Fired Steam Generator #1(Acid Rain, Phase II)	542680	2992650	65.00	213.25	338	43.1	36	6920
15	Fossil Fuel Fired Steam Generator #2(Acid Rain, Phase II)	542680	2992650	65.00	213.25	338	43.1	36	6920

Scenario 2 - PSD - Annual

Source ID	Source Description	Easting (X) (m)	Northing (Y) (m)	Base Elevation (m)	Stack Height (ft)	Temperature (°F)	Exit Velocity (fps)	Stack Diameter (ft)	SO2 (lb/hr)
6	23.4 MW CCGT with 8.2 MW HRSG Unit # 9	566120	3036350	20.73	68	426	59.8	11.2	319.51
9	Fossil Fuel Steam Generator Unit 4 (Phase II Acid Rain Unit)	561400	3056500	60.96	200	283	77.7	7	548
10	Pulverized Coal Main Boiler	547650	2990700	65.00	213.25	140	93.2	16	582
14	Fossil Fuel Fired Steam Generator #1(Acid Rain, Phase II)	542680	2992650	65.00	213.25	338	43.1	36	6920
15	Fossil Fuel Fired Steam Generator #2(Acid Rain, Phase II)	542680	2992650	65.00	213.25	338	43.1	36	6920

Potential (lb/hr)	Potential (tpy)	Allowable (lb/hr)	Allowable (tpy)	Distance (m)	200 Tons/Distance	Include in Inventory?
230.2	1008	230.2	1008	45036.91868	22.38163777	Yes
459.29	2011.5	459.29	2011.5	67164.43854	29.94888432	
459.29	2011.5	459.29	2011.5	67164.43854	29.94888432	
577	2527	577	2527	83445.14392	30.28336799	
577	2527	577	2527	83445.14392	30.28336799	
319.51	1395.82	319.51	1395.82	37817.98847	38.90360213	Yes
399.5	1750	399.5	1750	45036.91868	38.85701001	Yes
1072	4695	1072	4695	101490.2193	46.2606154	
548	2400	548	2400	45036.91868	53.28961373	Yes
582	2549	582	2549	37284.4558	68.36629221	Yes
1127.5	4938	1127.5	4938	45036.91868	109.6433802	Yes
8387.5	36737.25	8387.5	36737.25	89081.0764	412.4024034	
8387.5	36737.25	8387.5	36737.25	89081.0764	412.4024034	
6820	30309.8	6820	30309	33446.49513	906.1936052	Yes
6820	30309.8	6820	30309	33446.49513	906.1936052	Yes

3-hr

Middle of Sources 530451.6 (m) East
 AOI 1.1 (km)
 AOI + 50km 51100 (m)

3023781 (m) North

PSD Source?	NORTH (km)	EAST (km)	EU ID	EU DESCRIPTION	EU STATUS	STACK HT (m)	DIAM (ft)	EXIT TEMP (F)	VEL (ft/s)
no	3056.5	581.4	1	Fossil Fuel Steam Generator Unit No.1	A	200	3.5	289	105.5
yes	3035.4	464.3	2	19.535 MW SLOW SPEED DIESEL GENERATING UNIT 1	A	150	6	335	79
yes	3035.4	464.3	3	19.535 MW SLOW SPEED DIESEL GENERATING UNIT 2	A	150	6	350	79
no	3050.5	451.4	4	Gas Turbine Peaking Unit No. 1	A	55	10	850	424
no	3050.5	451.4	5	Gas Turbine Peaking Unit No. 2	A	55	10	850	424.4
yes	3036.35	566.12	6	23.4 MW CCGT with 8.2 MW HRSG Unit # 9	A	68	11.2	426	59.8
no	3056.5	561.4	7	Fossil Fuel Steam Generator Unit No.2	A	200	3.5	347	137.2
no	2943.7	592.8	8	FOSSIL FUEL STEAM GENERATOR #4 (Phase II, Acid Rain Unit)	A	115	7.5	293	55.8
yes	3056.5	581.4	9	Fossil Fuel Steam Generator Unit 4 (Phase II Acid Rain Unit)	A	200	7	283	77.7
yes	2990.7	547.65	10	Pulverized Coal Main Boiler	A	213.25	16	140	93.2
no	3056.5	581.4	11	Fossil Fuel Steam Generator Unit 3 (Phase II Acid Rain Unit)	A	200	6	342	68.6
no	2980.82	593.27	12	Fossil Fuel Steam Generator, Unit 3 -Phase II Acid Rain Unit	A	213.25	16	263	88.2
no	2960.62	593.27	13	Fossil Fuel Steam Generator, Unit 4 -Phase II Acid Rain Unit	A	213.25	16	263	87.3
yes	2992.85	542.68	14	Fossil Fuel Fired Steam Generator #1(Acid Rain, Phase II)	A	213.25	36	338	43.1
yes	2992.85	542.68	15	Fossil Fuel Fired Steam Generator #2(Acid Rain, Phase II)	A	213.25	36	338	43.1

NAAQS Sources

Scenario 2 - NAAQS - 3-hr

Source ID	Source Description	Easting (X) (m)	Northing (Y) (m)	Base Elevation (m)	Stack Height (ft)	Temperature (°F)	Exit Velocity (fps)	Stack Diameter (ft)	SO2 (lb/hr)
1	Fossil Fuel Steam Generator Unit No.1	561400	3056500	60.96	200	289	105.5	3.5	230.2
6	23.4 MW CCGT with 8.2 MW HRSG Unit # 9	566120	3036350	20.73	68	426	59.8	11.2	319.51
7	Fossil Fuel Steam Generator Unit No.2	561400	3056500	60.96	200	347	137.2	3.5	399.5
9	Fossil Fuel Steam Generator Unit 4 (Phase II Acid Rain Unit)	561400	3056500	60.96	200	283	77.7	7	548
10	Pulverized Coal Main Boiler	547650	2990700	65.00	213.25	140	93.2	16	582
11	Fossil Fuel Steam Generator Unit 3 (Phase II Acid Rain Unit)	561400	3056500	60.96	200	342	68.6	6	1127.5
14	Fossil Fuel Fired Steam Generator #1(Acid Rain, Phase II)	542680	2992650	65.00	213.25	338	43.1	36	6920
15	Fossil Fuel Fired Steam Generator #2(Acid Rain, Phase II)	542680	2992650	65.00	213.25	338	43.1	36	6920

Scenario 2 - PSD - 3-hr

Source ID	Source Description	Easting (X) (m)	Northing (Y) (m)	Base Elevation (m)	Stack Height (ft)	Temperature (°F)	Exit Velocity (fps)	Stack Diameter (ft)	SO2 (lb/hr)
6	23.4 MW CCGT with 8.2 MW HRSG Unit # 9	566120	3036350	20.73	68	426	59.8	11.2	319.51
9	Fossil Fuel Steam Generator Unit 4 (Phase II Acid Rain Unit)	561400	3056500	60.96	200	283	77.7	7	548
10	Pulverized Coal Main Boiler	547650	2990700	65.00	213.25	140	93.2	16	582
14	Fossil Fuel Fired Steam Generator #1(Acid Rain, Phase II)	542680	2992650	65.00	213.25	338	43.1	36	6920
15	Fossil Fuel Fired Steam Generator #2(Acid Rain, Phase II)	542680	2992650	65.00	213.25	338	43.1	36	6920

Potential (lb/hr)	Potential (tpy)	Allowable (lb/hr)	Allowable (tpy)	Distance (m)	200 Tons/Distance	Include in Inventory?
230.2	1008	230.2	1008	45036.91868	22.38183777	Yes
459.29	2011.5	459.29	2011.5	67164.43854	29.94888432	
459.29	2011.5	459.29	2011.5	67164.43854	29.94888432	
577	2527	577	2527	83445.14392	30.28336799	
577	2527	577	2527	83445.14392	30.28336799	
319.51	1395.82	319.51	1395.82	37817.88847	36.80360213	Yes
399.5	1750	399.5	1750	45038.91868	38.85701001	Yes
1072	4895	1072	4895	101490.2193	46.2608154	
548	2400	548	2400	45036.91868	53.28961373	Yes
582	2549	582	2549	37284.4558	68.36629221	Yes
1127.5	4938	1127.5	4938	45036.91868	109.8433802	Yes
8387.5	36737.25	8387.5	36737.25	89081.0764	412.4024034	
8387.5	36737.25	8387.5	36737.25	89081.0764	412.4024034	
6920	30309.6	6920	30309	33446.49513	906.1936052	Yes
6920	30309.6	6920	30309	33446.49513	906.1936052	Yes

24-hr

Middle of Sources 530451.8 (m) East
AOI 2.5 (km)
AOI + 50km 52500 (m)

3023781 (m) North

PSD Source?	NORTH (km)	EAST (km)	EU ID	EU DESCRIPTION	EU STATUS	STACK HT (ft)	DIAM (ft)	EXIT TEMP (F)	VEL (ft/s)
no	3056.5	561.4	1	Fossil Fuel Steam Generator Unit No.1	A	200	3.5	289	106.5
yes	3035.4	464.3	2	19.535 MW SLOW SPEED DIESEL GENERATING UNIT 1	A	150	6	335	79
yes	3035.4	464.3	3	19.535 MW SLOW SPEED DIESEL GENERATING UNIT 2	A	150	6	350	70
no	3050.5	451.4	4	Gas Turbine Peaking Unit No. 1	A	55	10	850	424
no	3050.5	451.4	5	Gas Turbine Peaking Unit No. 2	A	55	10	850	424.4
yes	3036.35	566.12	6	23.4 MW CCGT with 8.2 MW HRSG Unit # 9	A	68	11.2	426	59.8
no	3056.5	561.4	7	Fossil Fuel Steam Generator Unit No.2	A	200	3.5	347	137.2
no	2943.7	592.8	8	FOSSIL FUEL STEAM GENERATOR #4 (Phase II, Acid Rain Unit)	A	115	7.5	293	55.8
yes	3056.5	561.4	9	Fossil Fuel Steam Generator Unit 4 (Phase II Acid Rain Unit)	A	200	7	283	77.7
yes	2990.7	547.65	10	Pulverized Coal Main Boiler	A	213.25	16	140	93.2
no	3056.5	561.4	11	Fossil Fuel Steam Generator Unit 3 (Phase II Acid Rain Unit)	A	200	6	342	68.6
no	2960.62	593.27	12	Fossil Fuel Steam Generator, Unit 3 -Phase II Acid Rain Unit	A	213.25	16	263	86.2
no	2960.62	593.27	13	Fossil Fuel Steam Generator, Unit 4 -Phase II Acid Rain Unit	A	213.25	16	263	87.3
yes	2992.65	542.68	14	Fossil Fuel Fired Steam Generator #1(Acid Rain, Phase II)	A	213.25	36	338	43.1
yes	2992.65	542.68	15	Fossil Fuel Fired Steam Generator #2(Acid Rain, Phase II)	A	213.25	36	338	43.1

NAAQS Sources

Scenario 2 - NAAQS - 24-hr

Source ID	Source Description	Eastings (X) (m)	Northing (Y) (m)	Base Elevation (m)	Stack Height (ft)	Temperature (°F)	Exit Velocity (fps)	Stack Diameter (ft)	SO2 (lb/hr)
1	Fossil Fuel Steam Generator Unit No.1	561400	3056500	60.96	200	289	105.5	3.5	230.2
6	23.4 MW CCGT with 8.2 MW HRSG Unit # 9	566120	3036350	20.73	68	426	59.8	11.2	319.51
7	Fossil Fuel Steam Generator Unit No.2	561400	3056500	60.96	200	347	137.2	3.5	399.5
9	Fossil Fuel Steam Generator Unit 4 (Phase II Acid Rain Unit)	561400	3056500	60.96	200	283	77.7	7	548
10	Pulverized Coal Main Boiler	547650	2990700	65.00	213.25	140	93.2	16	582
11	Fossil Fuel Steam Generator Unit 3 (Phase II Acid Rain Unit)	561400	3056500	60.96	200	342	68.6	6	1127.5
14	Fossil Fuel Fired Steam Generator #1(Acid Rain, Phase II)	542680	2992650	65.00	213.25	338	43.1	36	6920
15	Fossil Fuel Fired Steam Generator #2(Acid Rain, Phase II)	542680	2992650	65.00	213.25	338	43.1	36	6920

Scenario 2 - PSD - 24-hr

Source ID	Source Description	Eastings (X) (m)	Northing (Y) (m)	Base Elevation (m)	Stack Height (ft)	Temperature (°F)	Exit Velocity (fps)	Stack Diameter (ft)	SO2 (lb/hr)
6	23.4 MW CCGT with 8.2 MW HRSG Unit # 9	566120	3036350	20.73	68	426	59.8	11.2	319.51
9	Fossil Fuel Steam Generator Unit 4 (Phase II Acid Rain Unit)	561400	3056500	60.96	200	283	77.7	7	548
10	Pulverized Coal Main Boiler	547650	2990700	65.00	213.25	140	93.2	16	582
14	Fossil Fuel Fired Steam Generator #1(Acid Rain, Phase II)	542680	2992650	65.00	213.25	338	43.1	36	6920
15	Fossil Fuel Fired Steam Generator #2(Acid Rain, Phase II)	542680	2992650	65.00	213.25	338	43.1	36	6920

Potential (lb/hr)	Potential (tpy)	Allowable (lb/hr)	Allowable (tpy)	Distance (m)	200 Tons/Distance	Include in Inventory?
230.2	1008	230.2	1008	45038.91868	22.38163777	Yes
459.29	2011.5	459.29	2011.5	67164.43854	29.94888432	
459.29	2011.5	459.29	2011.5	67164.43854	29.94888432	
577	2527	577	2527	83445.14392	30.28336799	
577	2527	577	2527	83445.14392	30.28336799	
319.51	1395.62	319.51	1395.62	37817.98847	36.90360213	Yes
399.5	1750	399.5	1750	45036.91868	38.85701001	Yes
1072	4695	1072	4695	101490.2193	46.2608154	
548	2400	548	2400	45036.91868	53.28961373	Yes
582	2549	582	2549	37284.4558	68.36629221	Yes
1127.5	4938	1127.5	4938	45036.91868	109.6433802	Yes
8387.5	36737.25	8387.5	36737.25	89081.0764	412.4024034	
8387.5	36737.25	8387.5	36737.25	89081.0764	412.4024034	
6920	30309.8	6920	30309	33446.49513	906.1936052	Yes
6920	30309.8	6920	30309	33446.49513	906.1936052	Yes

ANNUAL

Middle of Sources 530433.1 (m) East
 AOI 1.7 (km)
 AOI + 50km 51700 (m)

3023864 (m) North

PSD Source?	NORTH (km)	EAST (km)	EU ID	EU DESCRIPTION	EU STATUS	STACK HT (ft)	DIAM (ft)	EXIT TEMP (F)	VEL (ft/s)
no	3056.5	581.4	1	Fossil Fuel Steam Generator Unit No.1	A	200	3.5	289	105.5
yes	3035.4	464.3	2	19.535 MW SLOW SPEED DIESEL GENERATING UNIT 1	A	150	6	335	79
yes	3035.4	464.3	3	19.535 MW SLOW SPEED DIESEL GENERATING UNIT 2	A	150	8	350	79
no	3090.5	451.4	4	Gas Turbine Peaking Unit No. 1	A	55	10	850	424
no	3050.5	451.4	5	Gas Turbine Peaking Unit No. 2	A	56	10	850	424.4
yes	3038.35	586.12	6	23.4 MW CCGT with 8.2 MW HRSG Unit # 9	A	68	11.2	426	59.8
no	3056.5	581.4	7	Fossil Fuel Steam Generator Unit No.2	A	200	3.5	347	137.2
no	2943.7	592.8	8	FOSSIL FUEL STEAM GENERATOR #4 (Phase II, Acid Rain Unit)	A	115	7.5	293	55.8
yes	3058.5	581.4	9	Fossil Fuel Steam Generator Unit 4 (Phase II Acid Rain Unit)	A	200	7	283	77.7
yes	2980.7	547.85	10	Pulverized Coal Main Boiler	A	213.25	16	140	93.2
no	3058.5	581.4	11	Fossil Fuel Steam Generator Unit 3 (Phase II Acid Rain Unit)	A	200	6	342	66.6
no	2960.62	593.27	12	Fossil Fuel Steam Generator, Unit 3 -Phase II Acid Rain Unit	A	213.25	16	263	88.2
no	2960.62	593.27	13	Fossil Fuel Steam Generator, Unit 4 -Phase II Acid Rain Unit	A	213.25	16	263	87.3
yes	2992.65	542.68	14	Fossil Fuel Fired Steam Generator #1(Acid Rain, Phase II)	A	213.25	36	338	43.1
yes	2992.65	542.68	15	Fossil Fuel Fired Steam Generator #2(Acid Rain, Phase II)	A	213.25	36	338	43.1

NAAQS Sources

Scenario 2A - NAAQS - Annual

Source ID	Source Description	Easting (X) (m)	Northing (Y) (m)	Base Elevation (m)	Stack Height (ft)	Temperature (°F)	Exit Velocity (fps)	Stack Diameter (ft)	SO2 (lb/hr)
1	Fossil Fuel Steam Generator Unit No.1	661400	3056500	60.96	200	289	105.5	3.5	230.2
6	23.4 MW CCGT with 8.2 MW HRSG Unit # 9	566120	3036350	20.73	68	426	59.8	11.2	319.51
7	Fossil Fuel Steam Generator Unit No.2	561400	3056500	60.96	200	347	137.2	3.5	399.5
9	Fossil Fuel Steam Generator Unit 4 (Phase II Acid Rain Unit)	561400	3056500	60.96	200	283	77.7	7	548
10	Pulverized Coal Main Boiler	547850	2990700	65.00	213.25	140	93.2	16	582
11	Fossil Fuel Steam Generator Unit 3 (Phase II Acid Rain Unit)	561400	3056500	60.96	200	342	68.6	6	1127.5
14	Fossil Fuel Fired Steam Generator #1(Acid Rain, Phase II)	542680	2992650	65.00	213.25	338	43.1	36	6920
15	Fossil Fuel Fired Steam Generator #2(Acid Rain, Phase II)	542680	2992650	65.00	213.25	338	43.1	36	6920

Scenario 2A - PSD - Annual

Source ID	Source Description	Easting (X) (m)	Northing (Y) (m)	Base Elevation (m)	Stack Height (ft)	Temperature (°F)	Exit Velocity (fps)	Stack Diameter (ft)	SO2 (lb/hr)
6	23.4 MW CCGT with 8.2 MW HRSG Unit # 9	566120	3036350	20.73	68	426	59.8	11.2	319.51
9	Fossil Fuel Steam Generator Unit 4 (Phase II Acid Rain Unit)	561400	3056500	60.96	200	283	77.7	7	548
10	Pulverized Coal Main Boiler	547850	2990700	65.00	213.25	140	93.2	16	582
14	Fossil Fuel Fired Steam Generator #1(Acid Rain, Phase II)	542680	2992650	65.00	213.25	338	43.1	36	6920
15	Fossil Fuel Fired Steam Generator #2(Acid Rain, Phase II)	542680	2992650	65.00	213.25	338	43.1	36	6920

Potential (lb/yr)	Potential (tpy)	Allowable (lb/yr)	Allowable (tpy)	Distance (m)	200 Tons/Distance	Include in Inventory?
230.2	1008	230.2	1008	44989.52535	22.40521526	Yes
459.29	2011.5	459.29	2011.5	67131.70794	29.96348613	
459.29	2011.5	459.29	2011.5	67131.70794	29.96348613	
577	2527	577	2527	83400.88364	30.28943916	
577	2527	577	2527	83400.88364	30.28943916	
319.51	1395.62	319.51	1395.62	37808.13441	38.91322044	Yes
399.5	1750	399.5	1750	44989.52535	38.89794316	Yes
1072	4895	1072	4895	101567.2049	46.2255509	
548	2400	548	2400	44989.52535	53.34575082	Yes
582	2548	582	2548	37366.73041	68.21576231	Yes
1127.5	4938	1127.5	4938	44989.52535	109.7588819	Yes
8387.5	38737.25	8387.5	38737.25	89153.1241	412.0691268	
8387.5	38737.25	8387.5	38737.25	89153.1241	412.0691268	
6920	30309.6	6920	30309	33530.58836	903.9209118	Yes
6920	30309.6	6920	30309	33530.58836	903.9209118	Yes

3-hr

Middle of Sources 530433.1 (m) East
AOI 1.1 (km)
AOI + 50km 51100 (m)

3023864 (m) North

PSD Source?	NORTH (km)	EAST (km)	EU ID	EU DESCRIPTION	EU STATUS	STACK HT (ft)	DIAM (ft)	EXIT TEMP (F)	VEL (f/s)
no	3056.5	561.4	1	Fossil Fuel Steam Generator Unit No.1	A	200	3.5	289	105.5
yes	3035.4	464.3	2	19.535 MW SLOW SPEED DIESEL GENERATING UNIT 1	A	150	6	335	79
yes	3035.4	464.3	3	19.535 MW SLOW SPEED DIESEL GENERATING UNIT 2	A	150	6	350	79
no	3050.5	451.4	4	Gas Turbine Peaking Unit No. 1	A	55	10	850	424
no	3050.5	451.4	5	Gas Turbine Peaking Unit No. 2	A	55	10	850	424.4
yes	3036.35	566.12	6	23.4 MW CCGT with 8.2 MW HRSG Unit # 9	A	88	11.2	426	59.8
no	3058.5	561.4	7	Fossil Fuel Steam Generator Unit No.2	A	200	3.5	347	137.2
no	2943.7	592.8	8	FOSSIL FUEL STEAM GENERATOR #4 (Phase II, Acid Rain Unit)	A	115	7.5	293	55.8
yes	3058.5	561.4	9	Fossil Fuel Steam Generator Unit 4 (Phase II Acid Rain Unit)	A	200	7	283	77.7
yes	2990.7	547.65	10	Pulverized Coal Main Boiler	A	213.25	16	140	93.2
no	3058.5	561.4	11	Fossil Fuel Steam Generator Unit 3 (Phase II Acid Rain Unit)	A	200	6	342	68.6
no	2960.62	593.27	12	Fossil Fuel Steam Generator, Unit 3 -Phase II Acid Rain Unit	A	213.25	16	263	68.2
no	2960.62	593.27	13	Fossil Fuel Steam Generator, Unit 4 -Phase II Acid Rain Unit	A	213.25	16	263	67.3
yes	2992.65	542.68	14	Fossil Fuel Fired Steam Generator #1(Acid Rain, Phase II)	A	213.25	36	338	43.1
yes	2992.65	542.68	15	Fossil Fuel Fired Steam Generator #2(Acid Rain, Phase II)	A	213.25	36	338	43.1

NAAQS Sources

Scenario 2A - NAAQS - 3-hr

Source ID	Source Description	Easting (X) (m)	Northing (Y) (m)	Base Elevation (m)	Stack Height (ft)	Temperature (°F)	Exit Velocity (f/s)	Stack Diameter (ft)	SO2 (lb/hr)
1	Fossil Fuel Steam Generator Unit No.1	561400	3056500	60.96	200	289	105.5	3.5	230.2
6	23.4 MW CCGT with 8.2 MW HRSG Unit # 9	566120	3036350	20.73	88	426	59.8	11.2	319.51
7	Fossil Fuel Steam Generator Unit No.2	561400	3056500	60.96	200	347	137.2	3.5	399.5
9	Fossil Fuel Steam Generator Unit #4 (Phase II Acid Rain Unit)	561400	3056500	60.96	213.25	140	93.2	16	582
10	Pulverized Coal Main Boiler	547650	2990700	65.00	200	283	77.7	7	548
11	Fossil Fuel Steam Generator Unit 3 (Phase II Acid Rain Unit)	561400	3056500	60.96	200	342	68.6	6	1127.5
14	Fossil Fuel Fired Steam Generator #1(Acid Rain, Phase II)	542680	2992650	65.00	213.25	338	43.1	36	6920
15	Fossil Fuel Fired Steam Generator #2(Acid Rain, Phase II)	542680	2992650	65.00	213.25	338	43.1	36	6920

Scenario 2A - PSD - 3-hr

Source ID	Source Description	Easting (X) (m)	Northing (Y) (m)	Base Elevation (m)	Stack Height (ft)	Temperature (°F)	Exit Velocity (f/s)	Stack Diameter (ft)	SO2 (lb/hr)
6	23.4 MW CCGT with 8.2 MW HRSG Unit # 9	566120	3036350	20.73	88	426	59.8	11.2	319.51
9	Fossil Fuel Steam Generator Unit 4 (Phase II Acid Rain Unit)	561400	3056500	60.96	213.25	140	93.2	16	582
10	Pulverized Coal Main Boiler	547650	2990700	65.00	200	283	77.7	7	548
14	Fossil Fuel Fired Steam Generator #1(Acid Rain, Phase II)	542680	2992650	65.00	213.25	338	43.1	36	6920
15	Fossil Fuel Fired Steam Generator #2(Acid Rain, Phase II)	542680	2992650	65.00	213.25	338	43.1	36	6920

Potential (lb/hr)	Potential (tpy)	Allowable (lb/hr)	Allowable (tpy)	Distance (m)	200 Tons/Distance	Include in Inventory?
230.2	1008	230.2	1008	44989.52535	22.40521526	Yes
459.29	2011.5	459.29	2011.5	67131.70794	29.96348613	
459.29	2011.5	459.29	2011.5	67131.70794	29.96348613	
577	2527	577	2527	83400.88364	30.29943916	
577	2527	577	2527	83400.88364	30.29943916	
319.51	1395.62	319.51	1395.62	37808.13441	36.91322044	Yes
399.5	1750	399.5	1750	44989.52535	38.89794316	Yes
1072	4695	1072	4695	101567.2049	46.2255509	
548	2400	548	2400	44989.52535	53.34575062	Yes
582	2549	582	2549	37368.73041	68.21576231	Yes
1127.5	4938	1127.5	4938	44989.52535	109.7588819	Yes
8387.5	36737.25	8387.5	36737.25	89153.1241	412.0691268	
8387.5	36737.25	8387.5	36737.25	89153.1241	412.0691268	
6920	30309.6	6920	30309	33530.58836	903.9209118	Yes
6920	30309.6	6920	30309	33530.58836	903.9209118	Yes

24-hr

Middle of Sources 530433.1 (m) East
 AOI 2.5 (km)
 AOI + 50km 52500 (m)

3023864 (m) North

PSD Source?	NORTH (km)	EAST (km)	EU ID	EU DESCRIPTION	EU STATUS	STACK HT (ft)	DIAM (ft)	EXIT TEMP (F)	VEL (fvs)
no	3058.5	581.4	1	Fossil Fuel Steam Generator Unit No. 1	A	200	3.5	289	105.5
yes	3035.4	484.3	2	19.535 MW SLOW SPEED DIESEL GENERATING UNIT 1	A	150	8	335	79
yes	3035.4	484.3	3	19.535 MW SLOW SPEED DIESEL GENERATING UNIT 2	A	150	8	350	79
no	3050.5	451.4	4	Gas Turbine Peaking Unit No. 1	A	55	10	850	424
no	3050.5	451.4	5	Gas Turbine Peaking Unit No. 2	A	55	10	850	424.4
yes	3038.35	568.12	6	23.4 MW CCGT with 8.2 MW HRSG Unit # 9	A	68	11.2	426	59.8
no	3058.5	581.4	7	Fossil Fuel Steam Generator Unit No. 2	A	200	3.5	347	137.2
no	2943.7	592.8	8	FOSSIL FUEL STEAM GENERATOR #4 (Phase II, Acid Rain Unit)	A	115	7.5	293	55.8
yes	3068.5	581.4	9	Fossil Fuel Steam Generator Unit 4 (Phase II Acid Rain Unit)	A	200	7	283	77.7
yes	2990.7	547.65	10	Pulverized Coal Main Boiler	A	213.25	16	140	93.2
no	3058.5	581.4	11	Fossil Fuel Steam Generator Unit 3 (Phase II Acid Rain Unit)	A	200	6	342	88.6
no	2960.62	593.27	12	Fossil Fuel Steam Generator, Unit 3 -Phase II Acid Rain Unit	A	213.25	16	283	87.3
no	2960.62	593.27	13	Fossil Fuel Steam Generator, Unit 4 -Phase II Acid Rain Unit	A	213.25	16	338	43.1
yes	2992.65	542.68	14	Fossil Fuel Fired Steam Generator #1(Acid Rain, Phase II)	A	213.25	36	338	43.1
yes	2992.65	542.68	15	Fossil Fuel Fired Steam Generator #2(Acid Rain, Phase II)	A	213.25	36	338	43.1

NAAQS Sources

Scenario 2A - NAAQS - 24-hr

Source ID	Source Description	Easting (X) (m)	Northing (Y) (m)	Base Elevation (m)	Stack Height (ft)	Temperature (°F)	Exit Velocity (fps)	Stack Diameter (ft)	SO2 (lb/hr)
1	Fossil Fuel Steam Generator Unit No.1	561400	3058500	60.96	200	289	105.5	3.5	230.2
6	23.4 MW CCGT with 8.2 MW HRSG Unit # 9	566120	3036350	20.73	68	426	59.8	11.2	319.51
7	Fossil Fuel Steam Generator Unit No.2	561400	3058500	60.96	200	347	137.2	3.5	399.5
9	Fossil Fuel Steam Generator Unit 4 (Phase II Acid Rain Unit)	561400	3058500	60.96	213.25	283	77.7	7	548
10	Pulverized Coal Main Boiler	547650	2990700	65.00	213.25	140	93.2	16	582
11	Fossil Fuel Steam Generator Unit 3 (Phase II Acid Rain Unit)	561400	3058500	60.96	200	342	88.6	6	1127.5
14	Fossil Fuel Fired Steam Generator #1(Acid Rain, Phase II)	542680	2992650	65.00	213.25	338	43.1	36	6920
15	Fossil Fuel Fired Steam Generator #2(Acid Rain, Phase II)	542680	2992650	65.00	213.25	338	43.1	36	6920

Scenario 2A - PSD - 24-hr

Source ID	Source Description	Easting (X) (m)	Northing (Y) (m)	Base Elevation (m)	Stack Height (ft)	Temperature (°F)	Exit Velocity (fps)	Stack Diameter (ft)	SO2 (lb/hr)
6	23.4 MW CCGT with 8.2 MW HRSG Unit # 9	566120	3036350	20.73	68	426	59.8	11.2	319.51
9	Fossil Fuel Steam Generator Unit 4 (Phase II Acid Rain Unit)	561400	3058500	60.96	213.25	283	77.7	7	548
10	Pulverized Coal Main Boiler	547650	2990700	65.00	213.25	140	93.2	16	582
14	Fossil Fuel Fired Steam Generator #1(Acid Rain, Phase II)	542680	2992650	65.00	213.25	338	43.1	36	6920
15	Fossil Fuel Fired Steam Generator #2(Acid Rain, Phase II)	542680	2992650	65.00	213.25	338	43.1	36	6920

Potential (lb/yr)	Potential (tpy)	Allowable (lb/yr)	Allowable (tpy)	Distance (m)	200 Tons/Distance	Include in Inventory?
230.2	1006	230.2	1006	44989.52535	22.40521526	Yes
459.29	2011.5	459.29	2011.5	67131.70794	29.96348613	
459.29	2011.5	459.29	2011.5	67131.70794	29.96348613	
577	2527	577	2527	83400.88364	30.29943916	
577	2527	577	2527	83400.88364	30.29943916	
319.51	1395.62	319.51	1395.62	37808.13441	38.91322044	Yes
399.5	1750	399.5	1750	44989.52535	38.89794316	Yes
1072	4895	1072	4895	101567.2049	46.2255509	
548	2400	548	2400	44989.52535	53.34575062	Yes
582	2549	582	2549	37366.73041	68.21578231	Yes
1127.5	4939	1127.5	4939	44989.52535	109.7588819	Yes
8387.5	36737.25	8387.5	36737.25	89153.1241	412.0691268	
8387.5	36737.25	8387.5	36737.25	89153.1241	412.0691268	
8920	30309.6	8920	30309	33530.68836	903.9209118	Yes
8920	30309.6	8920	30309	33530.68836	903.9209118	Yes

Okeechobee
Changes to Off-Property Inventory

NOx

Action	Site Name	EU Description
1 Deleted - no emission information:	RINKER/MELBOURNE PLANT	FLYASH SILO
2 Deleted - no emission information:	FOUNTAINHEAD FUNERAL HOME	GAS FIRED CREMATOR W/AFTERBURNER CONTROL
3 Deleted - no emission information:	DICTAPHONE CORPORATION	POWDER CURE/DRY-OFF OVEN
4 Deleted - no emission information:	DICTAPHONE CORPORATION	BURN-OFF OVEN
5 Deleted - no emission information:	FAR RESEARCH INC	CHEMICAL SPECIALTY PROCESSES
6 Deleted - no emission information:	FIBERSTAR, INC.	Citrus Pulp Dryer
7 Deleted - no emission information:	FIBERSTAR, INC.	Citrus Pulp Dryer
8 Deleted - no emission information:	AVON PARK	Gas Turbine Peaking Unit No. 1
9 Deleted - no emission information:	AVON PARK	Gas Turbine Peaking Unit No. 2
10 Deleted - no emission information:	LAKE WALES BRANCH PLANT # 0410	Drum Mix Asphalt Plant - 200 ton per hour
11 Deleted - no emission information:	JAHNA CONCRETE, INC.	CEMENT STORAGE SILO DUST COLLECTOR W/ FILTER VENT
12 Deleted - no emission information:	PHILLIPS STATION	EMERGENCY DIESEL GENERATING UNIT
13 Deleted - no emission information:	HIGHLANDS CREMATORY, INC.	CREMATORY WITH AN AFTERBURNER
14 Deleted - no emission information:	AVON PARK CITRUS PROCESSING FACILITY	Citrus Feed Dryer & Waste Heat Evaporator
15 Deleted - no emission information:	AIRLITE PROCESSING/VERO BEACH FAC	PERLITE PROCESSING FURNACE #3
16 Deleted - no emission information:	OCEAN SPRAY CRANBERRIES/VERO BEACH	Citrus Peel Dryer #2
17 Deleted - no emission information:	OCEAN SPRAY CRANBERRIES/VERO BEACH	Emergency Generator
18 Deleted - no emission information:	NEW PIPER AIRCRAFT	ALUMINIUM CLEANING & ETCH LINE, ALUMINIUM SCRUBBER, TANK #5
19 Deleted - no emission information:	SYNGENTA CROP PROTECTION INC FKA NOVARTS	Biological waste incinerator/wastewater evaporator
20 Deleted - no emission information:	SOUTHEASTERN RACK COMPANY	VINYL ROCK COATING PROCESS(CURING OVEN, & SAND BLST)
21 Deleted - no emission information:	LOWTHER CREMATION SERVICES	HUMAN CREMATOR
22 Deleted - no emission information:	ELMO GREER & SONS	Portable Hot Mix Asphalt Plant
23 Deleted - no emission information:	MARTIN POWER PLANT	Two natural gas-fired fuel heaters
24 Deleted - no emission information:	MARTIN POWER PLANT	Diesel Generator for EUs 001 and 002
25 Deleted - no emission information:	LOUIS DREYFUS CITRUS / INDIANTOWN PLANT	1000 HP Boiler #1
26 Deleted - no emission information:	LOUIS DREYFUS CITRUS / INDIANTOWN PLANT	1000 HP Boiler #2
27 Deleted - no emission information:	LOUIS DREYFUS CITRUS / INDIANTOWN PLANT	1000 HP Boiler #3
28 Deleted - no emission information:	LOUIS DREYFUS CITRUS / INDIANTOWN PLANT	1000 HP Boiler #4
29 Deleted - no emission information:	LOUIS DREYFUS CITRUS / INDIANTOWN PLANT	Citrus Peel Dryer (#1A) / Waste Heat Evaporator
30 Deleted - no emission information:	TURBO COMBUSTOR TECHNOLOGY	Miscellaneous Operation
31 Deleted - no emission information:	INDIANTOWN COGENERATION PLANT	Aux Boilers (2)
32 Deleted - no emission information:	RALPH EVINRUDE TEST CENTER	Two fixed engine test cells
33 Deleted - no emission information:	MARTIN FUNERAL HOME AND CREMATORY	Crawford Equipment, Model C1000H Human Crematory
34 Deleted - no emission information:	OKEECHOBEE ASPHALT/ASPHALT PLANT	100 TPH ASPHALT DRUM MIXER WITH VENTURI SCRUBBER
35 Deleted - no emission information:	BUXTON FUNERAL HOME	Incinerator B&L Cremation Systems, Inc. N20 Series
36 Deleted - no emission information:	BERMAN ROAD LANDFILL	Municipal Solid Waste Landfill
37 Deleted - no emission information:	TWIN OAKS PET CEMETERY AND CREMATOTORIUM	A B&L System Incinerator (model BLP 500/150)
38 Deleted - no emission information:	TWIN OAKS PET CEMETERY AND CREMATOTORIUM	B&L CREMATION SYSTEMS INC. (MODEL BLP500/150)INCINERATOR
39 Deleted - no emission information:	OKEECHOBEE CREMATORY, LLC	MATTHEWS MODEL POWER-PAK II IE43PPII
40 Deleted - no emission information:	RELIANT ENERGY OSCEOLA	Pipeline natural gas heaters (2)
41 Deleted - no emission information:	OAK HAMMOCK DISPOSAL FACILITY	PHASE I-CLASS I LANDFILL GAS COLLECTION SYSTEM FLARE 2
42 Deleted - no emission information:	OKEELANTA CORP	Sugar silos Nos. 1, 2, and 3
43 Deleted - no emission information:	OKEELANTA CORP	Railcar sugar unloading receiver No. 1
44 Deleted - no emission information:	OKEELANTA CORP	Railcar sugar unloading receiver No. 2
45 Deleted - no emission information:	RIVIERA POWER PLANT	Emergency diesel generator, and mobile equip. & engines
46 Deleted - no emission information:	WEST PALM PLANT	Asphalt cement heater (1.4 mmBTUH) burning distillate oil
47 Deleted - no emission information:	PHYSICAL DISTRIBUTION CENTER & OSF	Wre Reclaim Furnace
48 Deleted - no emission information:	SOLID WASTE AUTHORITY OF PBC/NCRFF	Class I Landfill Flare (3500 scfm)
49 Deleted - no emission information:	VETERANS AFFAIRS MEDICAL CENTER	Fossil Fuel Fired Steam Generators
50 Deleted - no emission information:	VETERANS AFFAIRS MEDICAL CENTER	Electric Power Generators (five)
51 Deleted - no emission information:	COMMUNITY ASPHALT/WEST PALM BEACH PLANT	Asphalt cement heater
52 Deleted - no emission information:	ALL COUNTY FUNERAL HOME AND CREMATORY	HUMAN CREMATION INCINERATOR, IEE CO. #IE43-PPII (150 LB/HR)
53 Deleted - no emission information:	ALL COUNTY FUNERAL HOME AND CREMATORY	Human Cremation Incinerator IE43-PPII
54 Deleted - no emission information:	PALMS WEST CREMATORY (ROYAL PALM BEACH)	Human cremation incinerator
55 Deleted - no emission information:	BELLE GLADE ENERGY CENTER	Other Emissions Units
56 Deleted - no emission information:	TENDER LOVING PET SERVICES	Animal Crematory
57 Deleted - no emission information:	SOUTH FLORIDA MATERIALS CORP.	Two heaters for asphalt
58 Deleted - no emission information:	CITROSUCO NORTH AMERICA, INC.	BOILER NO 3 (2000HP)
59 Deleted - no emission information:	CITROSUCO NORTH AMERICA, INC.	New 1000 HP Boiler
60 Deleted - no emission information:	CITROSUCO NORTH AMERICA, INC.	2000 hp Boiler #1A
61 Deleted - no emission information:	CITROSUCO NORTH AMERICA, INC.	Two Emergency Generators
62 Deleted - no emission information:	CITRUS WORLD, INC.	300 KW Emergency Generator, North Office
63 Deleted - no emission information:	CITRUS WORLD, INC.	400 kw Emergency Generator, Power Generation Facility
64 Deleted - no emission information:	CITRUS WORLD, INC.	400 kw Emergency Generator, Water Reclamation Facility
65 Deleted - no emission information:	LAKE WALES MINE	ROTARY SAND DRYER
66 Deleted - no emission information:	C.C. CALHOUN SITE RF #7	Air Curtain Incinerator
67 Deleted - no emission information:	FT PIERCE UTILIM D KING PWR PLNT	General Purpose Internal Combustion Engines
68 Deleted - no emission information:	TROPICANA PRODUCTS	PEEL DRYER #1 & WASTE HEAT EVAPORATOR #1 W/SEPRTR. & WET CYCL
69 Deleted - no emission information:	TROPICANA PRODUCTS	STEAM GENERATOR #1
70 Deleted - no emission information:	TROPICANA PRODUCTS	STEAM GENERATOR #2
71 Deleted - no emission information:	TROPICANA PRODUCTS	PEEL DRYER #2 AND WASTE HEAT EVAPORATOR #2
72 Deleted - no emission information:	TROPICANA PRODUCTS	STEAM PACKAGED BOILER KEWANEE CLASSIC III MODEL H35-500G)
73 Deleted - no emission information:	DICKERSON/ASPHALT PLNT#14	275 TPH CONTIN. MIX ASPH.PLANT
74 Deleted - no emission information:	RANGER / FT. PIERCE	250T/HR JRECYCLE(50%) DRUM MIX(\$N666-88A)

Action	Site Name	EU Description
75 Deleted - no emission information:	ATLANTIC COAST RECYCLING	SECONDARY ALUMINUM SWEAT FURNACE #2
76 Deleted - no emission information:	FPL / ST LUCIE NUCLEAR POWER PLANT	4 MAIN PLANT EMERGENCY DIESEL GENERATORS, each with 2 engine
77 Deleted - no emission information:	FPL / ST LUCIE NUCLEAR POWER PLANT	2 BUILDING EMERGENCY DIESEL GENERATORS
78 Deleted - no emission information:	FPL / ST LUCIE NUCLEAR POWER PLANT	MISCELLANEOUS DIESEL DRIVEN EQUIPMENT
79 Deleted - no emission information:	TREASURE COAST TRACTOR SERVICE	Above Ground Air Curtain Incinerator
80 Deleted - no emission information:	TREASURE COAST ENERGY CENTER	Safe Shutdown Generator with 1000 gallon fuel oil tank.
81 Deleted - no emission information:	TREASURE COAST ENERGY CENTER	Diesel Engine Fire Pump with 500 gallon fuel tank.
82 Deleted - no emission information:	APAC-SOUTHEAST, INC. PORT ASP. PLNT #450	250 TPH Recycle Asphalt Pavement (RAP) Crusher
83 Deleted - no emission information:	TRS CONCRETE RECYCLING	Caterpillar diesel engine
84 Changed stack ht to 65 m	MARTIN POWER PLANT	Fossil Fuel Fired Steam Generator #1(Acid Rain, Phase II)
85 Changed stack ht to 65 m	MARTIN POWER PLANT	Fossil Fuel Fired Steam Generator #1(Acid Rain, Phase II)
86 Changed stack ht to 65 m	MARTIN POWER PLANT	Fossil Fuel Fired Steam Generator #2(Acid Rain, Phase II)
87 Changed stack ht to 65 m	MARTIN POWER PLANT	Fossil Fuel Fired Steam Generator #2(Acid Rain, Phase II)
88 Changed stack ht to 65 m	INDIANTOWN COGENERATION PLANT	Pulverized Coal Main Boiler
89 Changed stack ht to 65 m	RIVIERA POWER PLANT	Fossil Fuel Steam Generator, Unit 3 -Phase II Acid Rain Unit
90 Changed stack ht to 65 m	RIVIERA POWER PLANT	Fossil Fuel Steam Generator, Unit 3 -Phase II Acid Rain Unit
91 Changed stack ht to 65 m	RIVIERA POWER PLANT	Fossil Fuel Steam Generator, Unit 4 -Phase II Acid Rain Unit
92 Changed stack ht to 65 m	RIVIERA POWER PLANT	Fossil Fuel Steam Generator, Unit 4 -Phase II Acid Rain Unit
93 Deleted - 20D Method	ANIMAL RESCUE LEAGUE	ANIMAL CREMATION INCINERATOR; CRAWFORD #C-500P; 75 LB/HR
94 Deleted - 20D Method	PALM BCH CO ANIMAL CARE AND CONTROL	ANIMAL CREMATORY
95 Deleted - 20D Method	PRATT & WHITNEY AIRCRAFT	Water evaporator (EV-1-MW) wheat input of 0.2 MMBTUH
96 Deleted - 20D Method	SOUTHEASTERN RACK COMPANY	BURN OFF OVEN
97 Deleted - 20D Method	SCOBEE-COMBS-BOWDEN FUNERAL HOME	HUMAN CREMATION INCINERATOR, IEE CO. #IE43-PP11 (150 LB/HR)
98 Deleted - 20D Method	PARKWAY ASPHALT (RIVIERA)	Asphalt cement heater fired by No. 2 fuel oil
99 Deleted - 20D Method	ANIMAL RESCUE LEAGUE	ANIMAL CREMATION INCINERATOR; CRAWFORD #C-1000S; 250 LB/HR
100 Deleted - 20D Method	FOUNTAIN FUNERAL HOME	Crematory Industrial Equipment & Engineering IE43 Power-Pak
101 Deleted - 20D Method	EDGLEY CREMATORY, INC.	Two (2) identical but Independent Cremation Incinerators
102 Deleted - 20D Method	ST LUCIE CO INTL AIRPORT / INCINERATOR	SWMONDS MODEL 751-B INCINERATOR
103 Deleted - 20D Method	ROYAL PALM MEMORIAL GARDENS, INC.	HUMAN CREMATION INCINERATOR, IEE CO. #IE 43-PP11 (100 LB/HR)
104 Deleted - 20D Method	YATES FUNERAL HOME	INDUSTRIAL EQUIPMENT AND ENG MODEL IE43-PP11 INCINERATOR
105 Deleted - 20D Method	TREASURE COAST CREMATORY	HUMAN CREMATION INCINERATOR, MODEL #C-1000
106 Deleted - 20D Method	TREASURE COAST CREMATORY	HUMAN CREMATION INCINERATOR, C-1000
107 Deleted - 20D Method	NORTHWOOD FUNERAL HOME	HUMAN CREMATION INCINERATOR, IEE CO. #IE43-PP11 (150 LB/HR)
108 Deleted - 20D Method	INDIAN RIVER MEMORIAL HOSPITAL	BOILER #1 OIL FIRED 6.40 MMBTU/HR
109 Deleted - 20D Method	WEST FELDA TANK BATTERY	Flare with 4 heater/reaters & 3 tree water knockout vessels
110 Deleted - 20D Method	AYCOCK FUNERAL HOME	IND. EQUIP. & ENGR. MODEL IE43-PP11 INCINERATOR
111 Deleted - 20D Method	SPACE COAST CREMATORY	HUMAN CREMATORY
112 Deleted - 20D Method	BROWNLEE-MAXWELL FUNERAL HOME	HUMAN CREMATORY
113 Deleted - 20D Method	SIKORSKY AIRCRAFT CORP. - JUPITER	Paint spray booth (PS-13-SIK) with drying oven
114 Deleted - 20D Method	SIKORSKY AIRCRAFT CORP. - JUPITER	Small boiler (BO-4-SIK); fired by natural gas, 2.93 mmbtu/hr
115 Deleted - 20D Method	SOUTH FLORIDA SHAVINGS CO.	Wood shavings dryer
116 Deleted - 20D Method	ALICO ROAD ASPHALT PLANT	HEATER
117 Deleted - 20D Method	SEAWINDS CREMATORY	CRAWFORD MODEL C-100 HUMAN CREMATORY
118 Deleted - 20D Method	COMMUNITY ASPHALT	Cummins diesel engine, 4 cylinder
119 Deleted - 20D Method	ATLANTIC COAST RECYCLING	SECONDARY ALUMINUM SWEAT FURNACE #1
120 Deleted - 20D Method	RIVERFRONT GROVES	100 HP STEAM BOILER
121 Deleted - 20D Method	AIRLITE PROCESSING/VERD BEACH FAC	PERLITE EXPANDER FURNANCE #2
122 Deleted - 20D Method	VERO BEACH CITRUS PACKERS	SUPERIOR BOILER-300 HP-BURNING FUEL OIL
123 Deleted - 20D Method	SOUTHERN GARDENS CITRUS PROCESSING CORP.	BOILER #4
124 Deleted - 20D Method	HASLEY-HOBBS FUNERAL HOME	INCINERATOR - HUMAN REMAINS
125 Deleted - 20D Method	LEROY E SMITHS SONS	125 HP TITUSVILLE PROCESS STEAM BOILER MODEL #SPO-60
126 Deleted - 20D Method	LEHIGH ACRES SITE	Above-Ground Refractory-Lined Air Curtain Incinerator - S220
127 Deleted - 20D Method	PRATT & WHITNEY AIRCRAFT	Miscellaneous diesel engines driving generators, pumps, etc.
128 Deleted - 20D Method	VERO BEACH PLANT	ASPHALT DRUM-MIX PLANT
129 Deleted - 20D Method	PRATT & WHITNEY AIRCRAFT	Boiler (BO-14-E8) wheat input of 7 MMBTUH, propane fired
130 Deleted - 20D Method	PRATT & WHITNEY AIRCRAFT	Two furnaces (FU-3-MHT, FU-4-MHT), 6 MMBTUH each
131 Deleted - 20D Method	COMMUNITY ASPHALT	Caterpillar Diesel engine Model 3408
132 Deleted - 20D Method	MARTIN POWER PLANT	Unit 8A - 170 MW gas turbine with gas-fired HRSG
133 Deleted - 20D Method	MARTIN POWER PLANT	Unit 8B - 170 MW gas turbine with gas-fired HRSG
134 Deleted - 20D Method	MARTIN POWER PLANT	Unit 8B - 170 MW gas turbine with gas-fired HRSG
135 Deleted - 20D Method	MARTIN POWER PLANT	Unit 8C - 170 MW gas turbine with gas-fired HRSG
136 Deleted - 20D Method	MARTIN POWER PLANT	Unit 8C - 170 MW gas turbine with gas-fired HRSG
137 Deleted - 20D Method	MARTIN POWER PLANT	Unit 8D - 170 MW gas turbine with gas-fired HRSG
138 Deleted - 20D Method	MARTIN POWER PLANT	Unit 8D - 170 MW gas turbine with gas-fired HRSG
139 Deleted - 20D Method	AVON PARK CITRUS PROCESSING FACILITY	Boiler #1 750 hp Johnston
140 Deleted - 20D Method	AVON PARK CITRUS PROCESSING FACILITY	Boiler #2 750 hp Johnston
141 Deleted - 20D Method	PHYSICAL DISTRIBUTION CENTER & OSF	12.5 mmbtu/hr boiler #1 (Unit A) burning No.6 fuel oil
142 Deleted - 20D Method	PHYSICAL DISTRIBUTION CENTER & OSF	12.5 mmbtu/hr boiler #2 (Unit B) burning No.6 fuel oil
143 Deleted - 20D Method	MARTIN POWER PLANT	Unit 8A - 170 MW gas turbine with gas-fired HRSG
144 Deleted - 20D Method	MARTIN POWER PLANT	Unit 8B - 170 MW gas turbine with gas-fired HRSG
145 Deleted - 20D Method	MARTIN POWER PLANT	Unit 8C - 170 MW gas turbine with gas-fired HRSG
146 Deleted - 20D Method	MARTIN POWER PLANT	Unit 8C - 170 MW gas turbine with gas-fired HRSG
147 Deleted - 20D Method	MARTIN POWER PLANT	Unit 8D - 170 MW gas turbine with gas-fired HRSG
148 Deleted - 20D Method	PHILLIPS STATION	AUXILIARY STEAM BOILER
149 Deleted - 20D Method	GEORGIA PACIFIC CORP	BOILER #1
150 Deleted - 20D Method	GEORGIA PACIFIC CORP	BOILER #2
151 Deleted - 20D Method	CITROSUCO NORTH AMERICA, INC.	JOHNSTON 800 HP BOILER
152 Deleted - 20D Method	MARTIN NATURAL GAS METER STATION 701	Unit 1 - 10 MMBtu/hour gas-fired natural gas fuel heater
	MARTIN NATURAL GAS METER STATION 701	Unit 2 - 10 MMBtu/hour gas-fired natural gas fuel heater

Action	Site Name	EU Description
153 Deleted - 20D Method	FT PIERCE UTIL/H D KING PWR PLNT	16.5 MW Boiler Unit #6
154 Deleted - 20D Method	OCEAN SPRAY CRANBERRIES/VERO BEACH	500 HP PROCESS STEAM BOILER #3
155 Deleted - 20D Method	OCEAN SPRAY CRANBERRIES/VERO BEACH	OIL-FIRED PROCESS STEAM BOILER #1
156 Deleted - 20D Method	OCEAN SPRAY CRANBERRIES/VERO BEACH	OIL-FIRED PROCESS STEAM BOILER#2
157 Deleted - 20D Method	LAKE WALES BRANCH PLANT # 0410	Relocatable Non-Metallic Mineral Processing Plant
158 Deleted - 20D Method	U.S. SUGAR CLEWISTON MILL AND REFINERY	Granular carbon regeneration furnace
159 Deleted - 20D Method	HIGHLANDS COUNTY DEPT.OF SOLID WASTE	Landfill Gas Flare
160 Deleted - 20D Method	COMMUNITY ASPHALT/WEST PALM BEACH PLANT	Rotary drum mixer (300 TPH) fired by fuel oil
161 Deleted - 20D Method	LAKE PLACID ASPHALT PLANT	Asphalt Plant Barber-Greene Drum Mix
162 Deleted - 20D Method	SOLID WASTE AUTHORITY OF PBC/NCRRF	Class III Landfill with Flare
163 Deleted - 20D Method	ALICO ROAD ASPHALT PLANT	PORTABLE DRUM MIX ASPHALT PLANT
164 Deleted - 20D Method	PARKWAY ASPHALT (RIVIERA)	Asphalt rotary drum dryer (400 TPH); counterflow
165 Deleted - 20D Method	THE PACKERS OF INDIAN RIVER, INC.	STEAM BOILER - 6.27 MMBTU/HR
166 Deleted - 20D Method	CITROSUCO NORTH AMERICA, INC.	PEEL DRYER NO 2
167 Deleted - 20D Method	CITROSUCO NORTH AMERICA, INC.	PEEL DRYER NO 3
168 Deleted - 20D Method	SOUTHERN GARDENS CITRUS PROCESSING CORP.	BOILER #1 CLEAVER-BROOKS CBW200-800-200-ST 800 HP FIRETUBE
169 Deleted - 20D Method	SOUTHERN GARDENS CITRUS PROCESSING CORP.	BOILER #2 CLEAVER-BROOKS MODEL CBW200-800-200-ST 800 HP
170 Deleted - 20D Method	WEST PALM PLANT	Double drum dryer (250 TPH)
171 Deleted - 20D Method	SOUTHERN GARDENS CITRUS PROCESSING CORP.	BOILER #3, 800 HP FIRETUBE, 36 MMBTU/HR
172 Deleted - 20D Method	INDIAN TRAIL IMPROVEMENT DISTRICT - ACI	Air curtain incinerator with compacted limestone pit
173 Deleted - 20D Method	NEW PIPER AIRCRAFT	HOT WATER HEATERS/STEAM BOILERS
174 Deleted - 20D Method	TREASURE COAST LAND CLEARING	Air Burners, LLC, model T-350 ACI
175 Deleted - 20D Method	AVON PARK CITRUS PROCESSING FACILITY	PELLET MILL COOLER
176 Deleted - 20D Method	CITRUS WORLD, INC.	GAS TURBINE NO. 2 WWW BOILER
177 Deleted - 20D Method	CITRUS BELLE	Boiler No. 5
178 Deleted - 20D Method	OCEAN SPRAY CRANBERRIES/VERO BEACH	CITRUS PEEL DRYER #1
179 Deleted - 20D Method	EAST COAST PAVING - LOXAHATCHEE PLANT	Hot mix asphalt plant (175 TPH)
180 Deleted - 20D Method	FROSTPROOF CITRUS PROCESSING FACILITY	CLEAVER BROOKS BOILER MODEL P-52-E DESIGNATED AS NO. 3
181 Deleted - 20D Method	FROSTPROOF CITRUS PROCESSING FACILITY	PROCESS STEAM BOILER #2
182 Deleted - 20D Method	PRATT & WHITNEY AIRCRAFT	Boiler (BC-12-E8) wheat input of 42 mmBTU/HR in Test Area E
183 Deleted - 20D Method	LOUIS DREYFUS CITRUS / INDIANTOWN PLANT	30 T/HR CITRUS PEEL DRYER #2
184 Deleted - 20D Method	INDIAN RIVER MEMORIAL HOSPITAL	200 HP STEAM BOILER #2
185 Deleted - 20D Method	FGTC COMPRESSOR STATION 21	COMPRESSOR #2101, 6500 BHP NATURAL GAS FIRED TURBINE
186 Deleted - 20D Method	FGTC COMPRESSOR STATION 21	COMPRESSOR #2102, 6500 BHP NATURAL GAS FIRED TURBINE
187 Deleted - 20D Method	MARTIN POWER PLANT	Unit 8A - 170 MW gas turbine with gas-fired HRSG
188 Deleted - 20D Method	MARTIN POWER PLANT	Unit 8B - 170 MW gas turbine with gas-fired HRSG
189 Deleted - 20D Method	MARTIN POWER PLANT	Unit 8C - 170 MW gas turbine with gas-fired HRSG
190 Deleted - 20D Method	MARTIN POWER PLANT	Unit 8D - 170 MW gas turbine with gas-fired HRSG
191 Deleted - 20D Method	SOUTH FLORIDA THERMAL SERVICES, INC.	THERMAL SOIL TREATMENT PLANT WITH AFTERBURNER & BAGHOUSE
192 Deleted - 20D Method	CITRUS WORLD, INC.	WASTE HEAT BOILER 91.38 MMBTU/HR NATURAL GAS FIRED
193 Deleted - 20D Method	MARTIN CO/PALM CITY II SANITARY LANDFILL	New 2,000 scfm non-assisted open flare
194 Deleted - 20D Method	PRATT & WHITNEY AIRCRAFT	Miscellaneous air and fuel heaters fired with natural gas
195 Deleted - 20D Method	R. A. CONNOR PAVING, INC.	AIR CURTAIN INCINERATOR, MODEL T-359
196 Deleted - 20D Method	MARTIN POWER PLANT	Unit 8A - 170 MW gas turbine with gas-fired HRSG
197 Deleted - 20D Method	MARTIN POWER PLANT	Unit 8A - 170 MW gas turbine with gas-fired HRSG
198 Deleted - 20D Method	MARTIN POWER PLANT	Unit 8B - 170 MW gas turbine with gas-fired HRSG
199 Deleted - 20D Method	MARTIN POWER PLANT	Unit 8B - 170 MW gas turbine with gas-fired HRSG
200 Deleted - 20D Method	MARTIN POWER PLANT	Unit 8C - 170 MW gas turbine with gas-fired HRSG
201 Deleted - 20D Method	MARTIN POWER PLANT	Unit 8C - 170 MW gas turbine with gas-fired HRSG
202 Deleted - 20D Method	MARTIN POWER PLANT	Unit 8D - 170 MW gas turbine with gas-fired HRSG
203 Deleted - 20D Method	MARTIN POWER PLANT	Unit 8D - 170 MW gas turbine with gas-fired HRSG
204 Deleted - 20D Method	CITRUS WORLD, INC.	Unit 8D - 170 MW gas turbine with gas-fired HRSG
205 Deleted - 20D Method	ST LUCIE CO/GLADES ROAD LANDFILL	ERIE CITY KEYSTONE BOILER #1 USING NAT GAS AND #2 OIL
206 Deleted - 20D Method	FGTC COMPRESSOR STATION 19	2000 scfm non-assisted Open Flare
207 Deleted - 20D Method	FGTC COMPRESSOR STATION 19	I. C. Engine No. 1901 (2600) NG fired 4 Stroke Lean Burn
208 Deleted - 20D Method	MARTIN POWER PLANT	I. C. Engine No. 1902 (2600) NG fired 4 Stroke Lean Burn
209 Deleted - 20D Method	CITRUS WORLD, INC.	Auxiliary Boiler
210 Deleted - 20D Method	PRATT & WHITNEY AIRCRAFT	ERIE CITY KEYSTONE BOILER #3 USING NAT GAS AND #2 OIL
211 Deleted - 20D Method	OKEELANTA CORP	CT Test Islands
212 Deleted - 20D Method	OKEELANTA CORP	Boiler 16 - 130,000 lb/hr steam rate (gas/oil)
213 Deleted - 20D Method	APAC-SOUTHEAST, INC. PORT ASP. PLNT #450	Boiler 16 - 150,000 lb/hr steam rate (gas/oil)
214 Deleted - 20D Method	CITRUS BELLE	PORTABLE DRUM MIX ASPHALT PLANT
215 Deleted - 20D Method	WYNNE RANCH SITE (ORANGE AVE.)	Boiler No. 2
216 Deleted - 20D Method	LAKE PLACID ASPHALT PLANT	Above-ground ACI
217 Deleted - 20D Method	DANIEL P. MAYS/CHURCH ROAD SITE	Relocatable crusher for asphalt, concrete & rock
218 Deleted - 20D Method	APAC-SOUTHEAST, INC. PORT ASP. PLNT #450	Portable Refractory-Line Air Curtain Incinerator
219 Deleted - 20D Method	NORTH CYPRESS RESERVE	320 HP Diesel Engine and the 100 KW Power generator
220 Deleted - 20D Method	TROPICANA PRODUCTS	Air Curtain Incinerator
221 Deleted - 20D Method	ATLANTIC SUGAR MILL	New Process Steam Boiler
222 Deleted - 20D Method	U.S. SUGAR CLEWISTON MILL AND REFINERY	Boiler 5 - 113,000 lb/hr steam rate
223 Deleted - 20D Method	SOUTHERN GARDENS CITRUS PROCESSING CORP.	Boiler 7 - 385,000 lb/hr steam rate (1-hr max.)
224 Deleted - 20D Method	MARTIN POWER PLANT	Backup Peel Dryer No 2
225 Deleted - 20D Method	MARTIN POWER PLANT	Unit 8A - 170 MW gas turbine with gas-fired HRSG
226 Deleted - 20D Method	MARTIN POWER PLANT	Unit 8B - 170 MW gas turbine with gas-fired HRSG
227 Deleted - 20D Method	MARTIN POWER PLANT	Unit 8B - 170 MW gas turbine with gas-fired HRSG
228 Deleted - 20D Method	MARTIN POWER PLANT	Unit 8C - 170 MW gas turbine with gas-fired HRSG
229 Deleted - 20D Method	MARTIN POWER PLANT	Unit 8C - 170 MW gas turbine with gas-fired HRSG
230 Deleted - 20D Method	MARTIN POWER PLANT	Unit 8D - 170 MW gas turbine with gas-fired HRSG
	MARTIN POWER PLANT	Unit 8D - 170 MW gas turbine with gas-fired HRSG

Action	Site Name	EU Description
231 Deleted - 20D Method	CITRUS WORLD, INC.	NATURAL GAS TURBINE @ 51.1MMBTU/HR (APPROX. 66 DEG. F)
232 Deleted - 20D Method	FROSTPROOF CITRUS PROCESSING FACILITY	500 HP ERIE CITY PROCESS STEAM BOILER #1
233 Deleted - 20D Method	INDIANTOWN COGENERATION PLANT	(2) Auxiliary Boilers and Temporary Auxiliary Boiler
234 Deleted - 20D Method	TCSC SEBRING PLANT	VOC Fume Collection System/Thermal Oxidizer
235 Deleted - 20D Method	SOUTHERN GARDENS CITRUS PROCESSING CORP.	CITRUS FEED MILL WITH WASTE HEAT EVAPORATOR
236 Deleted - 20D Method	OKEELANTA CORP	Boiler 18 - 150,000 lb/hr steam rate (gas/oil)
237 Deleted - 20D Method	OKEELANTA CORP	Boiler 16 - 150,000 lb/hr steam rate (gas/oil)
238 Deleted - 20D Method	MARTIN POWER PLANT	Unit 8A - 170 MW gas turbine with gas-fired HRSG
239 Deleted - 20D Method	MARTIN POWER PLANT	Unit 8B - 170 MW gas turbine with gas-fired HRSG
240 Deleted - 20D Method	MARTIN POWER PLANT	Unit 8C - 170 MW gas turbine with gas-fired HRSG
241 Deleted - 20D Method	MARTIN POWER PLANT	Unit 8D - 170 MW gas turbine with gas-fired HRSG
242 Deleted - 20D Method	PRATT & WHITNEY AIRCRAFT	2 boilers (BO-1-MBH,BO-2-BMH); 54 MMBTU/hr each, at BH
243 Deleted - 20D Method	CEMEX, INC.	ship unloader with 3 diesel engines and a dust collector
244 Deleted - 20D Method	SUGAR CANE GROWERS CO-OP	BOILER #2 WITH 1 SCRUBBER AND 1 STACK
245 Deleted - 20D Method	RELIANT ENERGY OSCEOLA	170 MW Simple Cycle Combustion Turbine
246 Deleted - 20D Method	RELIANT ENERGY OSCEOLA	170 MW Simple Cycle Combustion Turbine
247 Deleted - 20D Method	RELIANT ENERGY OSCEOLA	170 MW Simple Cycle Combustion Turbine
248 Deleted - 20D Method	CITRUS WORLD, INC.	CITRUS PEEL DRYER WITH WASTE-HEAT EVAPORATOR #1
249 Deleted - 20D Method	CITRUS WORLD, INC.	ERIE CITY KEYSTONE BOILER #2 USING NAT GAS AND #2 OIL
250 Deleted - 20D Method	FGTC COMPRESSOR STATION 19	I. C. Engine No. 1803 (5000) NG fired 2 Stroke Lean
251 Deleted - 20D Method	RELIANT ENERGY OSCEOLA	170 MW Simple Cycle Combustion Turbine
252 Deleted - 20D Method	RELIANT ENERGY OSCEOLA	170 MW Simple Cycle Combustion Turbine
253 Deleted - 20D Method	RELIANT ENERGY OSCEOLA	170 MW Simple Cycle Combustion Turbine
254 Deleted - 20D Method	GRANT (VALKARIA) PLANT	DRUM MIX ASPHALT PLANT
255 Deleted - 20D Method	TROPICANA PRODUCTS	New Process Steam Boiler
256 Deleted - 20D Method	BELLE GLADE ENERGY CENTER	249.8 MW Combined Cycle Unit
257 Deleted - 20D Method	FGTC COMPRESSOR STATION 20	2400 BHP NAT GAS FIRED RECIP IC ENGINE #2004
258 Deleted - 20D Method	OSCEOLA FARMS	BOILER #3 WITH SCRUBBER
259 Deleted - 20D Method	FROSTPROOF CITRUS PROCESSING FACILITY	CITRUS PEEL DRYER W/ WASTE HEAT EVAPORATOR
260 Deleted - 20D Method	U.S. SUGAR CLEWISTON MILL AND REFINERY	Boiler 3 - 130,000 lb/hr steam rate (1-hr max.)
261 Deleted - 20D Method	BELLE GLADE ENERGY CENTER	175 MW Simple Cycle Unit
262 Deleted - 20D Method	BELLE GLADE ENERGY CENTER	175 MW Simple Cycle Unit
263 Deleted - 20D Method	BIOMASS PROCESSING FACILITY - OKEECHOBEE	Kewanee Packaged Scotch Boiler
264 Deleted - 20D Method	MARTIN POWER PLANT	Unit 8A - 170 MW gas turbine with gas-fired HRSG
265 Deleted - 20D Method	MARTIN POWER PLANT	Unit 8A - 170 MW gas turbine with gas-fired HRSG
266 Deleted - 20D Method	MARTIN POWER PLANT	Unit 8B - 170 MW gas turbine with gas-fired HRSG
267 Deleted - 20D Method	MARTIN POWER PLANT	Unit 8B - 170 MW gas turbine with gas-fired HRSG
268 Deleted - 20D Method	MARTIN POWER PLANT	Unit 8C - 170 MW gas turbine with gas-fired HRSG
269 Deleted - 20D Method	MARTIN POWER PLANT	Unit 8C - 170 MW gas turbine with gas-fired HRSG
270 Deleted - 20D Method	MARTIN POWER PLANT	Unit 8D - 170 MW gas turbine with gas-fired HRSG
271 Deleted - 20D Method	MARTIN POWER PLANT	Unit 8D - 170 MW gas turbine with gas-fired HRSG
272 Deleted - 20D Method	OSCEOLA FARMS	BOILER #6 WITH SCRUBBER PSD
273 Deleted - 20D Method	U.S. SUGAR CLEWISTON MILL AND REFINERY	DIESEL ELECTRIC GENERATOR #1. GENERAL MOTORS MODEL 16-567-CE
274 Deleted - 20D Method	U.S. SUGAR CLEWISTON MILL AND REFINERY	DIESEL GENERATOR #2. GENERAL MOTORS MODEL #16-567-B
275 Deleted - 20D Method	CITRUS WORLD, INC.	CITRUS PEEL DRYER WITH WASTE-HEAT EVAPORATOR #2
276 Deleted - 20D Method	CITRUS WORLD, INC.	CITRUS PEEL DRYER WITH WASTE-HEAT EVAPORATOR #3
277 Deleted - 20D Method	MARTIN POWER PLANT	Unit 8A - 170 MW gas turbine with gas-fired HRSG
278 Deleted - 20D Method	MARTIN POWER PLANT	Unit 8B - 170 MW gas turbine with gas-fired HRSG
279 Deleted - 20D Method	MARTIN POWER PLANT	Unit 8B - 170 MW gas turbine with gas-fired HRSG
280 Deleted - 20D Method	MARTIN POWER PLANT	Unit 8C - 170 MW gas turbine with gas-fired HRSG
281 Deleted - 20D Method	MARTIN POWER PLANT	Unit 8C - 170 MW gas turbine with gas-fired HRSG
282 Deleted - 20D Method	MARTIN POWER PLANT	Unit 8D - 170 MW gas turbine with gas-fired HRSG
283 Deleted - 20D Method	MARTIN POWER PLANT	Unit 8D - 170 MW gas turbine with gas-fired HRSG
284 Deleted - 20D Method	TOM G. SMITH POWER PLANT	7.5 MW FOSSIL FUEL STEAM GENERATING UNIT I
285 Deleted - 20D Method	MARTIN POWER PLANT	Unit 8A - 170 MW gas turbine with gas-fired HRSG
286 Deleted - 20D Method	MARTIN POWER PLANT	Unit 8B - 170 MW gas turbine with gas-fired HRSG
287 Deleted - 20D Method	MARTIN POWER PLANT	Unit 8C - 170 MW gas turbine with gas-fired HRSG
288 Deleted - 20D Method	MARTIN POWER PLANT	Unit 8D - 170 MW gas turbine with gas-fired HRSG
289 Deleted - 20D Method	FGTC COMPRESSOR STATION 20	4000 BHP I.C. Reciprocating Engine & Assoc. Equip. #2005
290 Deleted - 20D Method	OAK HAMMOCK DISPOSAL FACILITY	PHASE I-CLASS I LANDFILL GAS COLLECTION SYSTEM FLARE 1
291 Deleted - 20D Method	TREASURE COAST ENERGY CENTER	GE PG7241 FA CT (170 MW), HRSG w/ DB, STG (130 MW)
292 Deleted - 20D Method	TREASURE COAST ENERGY CENTER	GE PG7241 FA CT (170 MW), HRSG w/ DB, STG (130 MW)
293 Deleted - 20D Method	TREASURE COAST ENERGY CENTER	GE PG7241 FA CT (170 MW), HRSG w/ DB, STG (130 MW)
294 Deleted - 20D Method	TREASURE COAST ENERGY CENTER	GE PG7241 FA CT (170 MW), HRSG w/ DB, STG (130 MW)
295 Deleted - 20D Method	TREASURE COAST ENERGY CENTER	GE PG7241 FA CT (170 MW), HRSG w/ DB, STG (130 MW)
296 Deleted - 20D Method	TREASURE COAST ENERGY CENTER	GE PG7241 FA CT (170 MW), HRSG w/ DB, STG (130 MW)
297 Deleted - 20D Method	TREASURE COAST ENERGY CENTER	GE PG7241 FA CT (170 MW), HRSG w/ DB, STG (130 MW)
298 Deleted - 20D Method	TREASURE COAST ENERGY CENTER	GE PG7241 FA CT (170 MW), HRSG w/ DB, STG (130 MW)
299 Deleted - 20D Method	SPWMD PUMP STATION G-310	SICE-Six engines driving four pumps and two generators
300 Deleted - 20D Method	SPWMD PUMP STATION G-310	SICE-Six engines driving four pumps and two generators
301 Deleted - 20D Method	SPWMD PUMP STATION S-362	Three - 1303 bhp and two - 839 hp diesel engines.
302 Deleted - 20D Method	ATLANTIC SUGAR MILL	Boiler 4 - 125,000 lb/hr steam rate
303 Deleted - 20D Method	SPWMD PUMP STATION S-319	Three - 2005 bhp and two - 1210 bhp diesel engines
304 Deleted - 20D Method	ATLANTIC SUGAR MILL	Boiler 3 - 130,000 lb/hr steam rate
305 Deleted - 20D Method	U.S. SUGAR CLEWISTON MILL AND REFINERY	Boiler 1 - 255,000 lb/hr steam rate (1-hr max.)
306 Deleted - 20D Method	U.S. SUGAR CLEWISTON MILL AND REFINERY	Boiler 2 - 230,000 lb/hr steam rate (1-hr max.)
307 Deleted - 20D Method	SUGAR CANE GROWERS CO-OP	BOILER #3 WITH 1 SCRUBBER AND 1 STACK
308 Deleted - 20D Method	MARTIN POWER PLANT	Unit 8B - 170 MW gas turbine with gas-fired HRSG

Action	Site Name	EU Description
309 Deleted - 20D Method	MARTIN POWER PLANT	Unit 8C - 170 MW gas turbine with gas-fired HRSG
310 Deleted - 20D Method	MARTIN POWER PLANT	Unit 8D - 170 MW gas turbine with gas-fired HRSG
311 Deleted - 20D Method	MARTIN POWER PLANT	Unit 8A - 170 MW gas turbine with gas-fired HRSG
312 Deleted - 20D Method	MARTIN POWER PLANT	Unit 8B - 170 MW gas turbine with gas-fired HRSG
313 Deleted - 20D Method	MARTIN POWER PLANT	Unit 8C - 170 MW gas turbine with gas-fired HRSG
314 Deleted - 20D Method	MARTIN POWER PLANT	Unit 8D - 170 MW gas turbine with gas-fired HRSG
315 Deleted - 20D Method	ATLANTIC SUGAR MILL	Boiler 1 - 150,000 lb/hr steam rate
316 Deleted - 20D Method	ATLANTIC SUGAR MILL	Boiler 1 - 150,000 lb/hr steam rate
317 Deleted - 20D Method	ATLANTIC SUGAR MILL	Boiler 2 - 150,000 lb/hr steam rate
318 Deleted - 20D Method	PRATT & WHITNEY AIRCRAFT	Emergency electrical generating facility
319 Deleted - 20D Method	BIOMASS PROCESSING FACILITY - OKEECHOBEE	Packaged Water-Tube Boiler
320 Deleted - 20D Method	U.S. SUGAR CLEWISTON MILL AND REFINERY	Boiler 4 - 300,000 lb/hr steam rate (1-hr max.)
321 Deleted - 20D Method	OSCEOLA FARMS	BAGASSE BOILER #4 (UNIT #5), 140,000 LBS/HR STEAM
322 Deleted - 20D Method	OSCEOLA FARMS	BOILER #2 WITH 2 SCRUBBERS AND 2 STACKS
323 Deleted - 20D Method	TOM G. SMITH POWER PLANT	2000 KW DIESEL GENERATOR # 1 PEAKING UNIT
324 Deleted - 20D Method	TOM G. SMITH POWER PLANT	2000 KW DIESEL GENERATOR # 2 PEAKING UNIT
325 Deleted - 20D Method	TOM G. SMITH POWER PLANT	2000 KW DIESEL GENERATOR # 3 PEAKING UNIT
326 Deleted - 20D Method	TOM G. SMITH POWER PLANT	2000 KW DIESEL GENERATOR # 4 PEAKING UNIT
327 Deleted - 20D Method	TOM G. SMITH POWER PLANT	2000 KW DIESEL GENERATOR # 5 PEAKING UNIT
328 Deleted - 20D Method	U.S. SUGAR CORP. BRYANT MILL	DIESEL ELECTRIC GENERATOR GENERAL MOTORS MODEL 16-567-B
329 Deleted - 20D Method	OSCEOLA FARMS	185,000 LB/HR BAGASSE BOILER # 5 WITH 2 SCRUBBERS & 2 STACKS
330 Deleted - 20D Method	U.S. SUGAR CORP. BRYANT MILL	DIESEL ELECTRIC GENERATOR GENERAL MOTORS MODEL 16-567-C
331 Deleted - 20D Method	CITY OF VERO BEACH MUNICIPAL UTILITIES	Combined Cycle Gas Turbine Unit 5 (Phase II Acid Rain Unit)
332 Deleted - 20D Method	CITY OF VERO BEACH MUNICIPAL UTILITIES	Combined Cycle Gas Turbine Unit 5 (Phase II Acid Rain Unit)
333 Deleted - 20D Method	FGTC COMPRESSOR STATION 20	1500 BHP NAT GAS FIRED RECIP IC ENGINE #2001
334 Deleted - 20D Method	FGTC COMPRESSOR STATION 20	1500 BHP NAT GAS FIRED RECIP IC ENGINE #2002
335 Deleted - 20D Method	U.S. SUGAR CORP. BRYANT MILL	BOILER #1 WITH SCRUBBER
336 Deleted - 20D Method	U.S. SUGAR CORP. BRYANT MILL	BOILER #2 WITH SCRUBBERS
337 Deleted - 20D Method	U.S. SUGAR CORP. BRYANT MILL	BOILER #3 WITH SCRUBBER
338 Deleted - 20D Method	SUGAR CANE GROWERS CO-OP	BOILER # 8 WITH 2 SCRUBBERS AND 1 STACK
339 Deleted - 20D Method	SUGAR CANE GROWERS CO-OP	BOILER #1 WITH 1 SCRUBBER AND 1 STACK
340 Deleted - 20D Method	SUGAR CANE GROWERS CO-OP	BOILER #2 WITH 1 SCRUBBER AND 1 STACK
341 Deleted - 20D Method	U.S. SUGAR CLEWISTON MILL AND REFINERY	Boiler 8 - Bagasse boiler rated at 500,000 lb/hour steam
342 Deleted - 20D Method	TOM G. SMITH POWER PLANT	COMBINED CYCLE UNIT (GT-2/S-5)
343 Deleted - 20D Method	TOM G. SMITH POWER PLANT	FOSSIL FUEL STEAM GENERATOR #3 (Phase II, Acid Rain Unit)
344 Deleted - 20D Method	U.S. SUGAR CORP. BRYANT MILL	BOILER #5 WITH TWO SCRUBBERS
345 Deleted - 20D Method	FGTC COMPRESSOR STATION 20	2000 BHP NAT GAS FIRED RECIP IC ENGINE #2003
346 Deleted - 20D Method	TOM G. SMITH POWER PLANT	FOSSIL FUEL STEAM GENERATOR #4 (Phase II, Acid Rain Unit)
347 Deleted - 20D Method	PRATT & WHITNEY AIRCRAFT	Air compressor/heater (ACHR-2-B2)
348 Deleted - 20D Method	MARTIN POWER PLANT	Diesel Generator (0.718 MW for Units 003-006)
349 Deleted - 20D Method	SUGAR CANE GROWERS CO-OP	BOILER #5 WITH 2 SCRUBBERS AND 1 STACK
350 Deleted - 20D Method	OKEELANTA COGENERATION PLANT	Cogeneration Boiler A - 715 MMBtu/hr spreader stoker boiler
351 Deleted - 20D Method	OKEELANTA COGENERATION PLANT	Cogeneration Boiler B - 715 MMBtu/hr spreader stoker boiler
352 Deleted - 20D Method	OKEELANTA COGENERATION PLANT	Cogeneration Boiler C - 715 MMBtu/hr spreader stoker boiler
353 Deleted - 20D Method	FT PIERCE UTIL/D KING PWR PLNT	2.75 MW West Diesel #1
354 Deleted - 20D Method	FT PIERCE UTIL/D KING PWR PLNT	2.75 MW East Diesel #2
355 Deleted - 20D Method	CITY OF VERO BEACH MUNICIPAL UTILITIES	Fossil Fuel Steam Generator Unit No.1
356 Deleted - 20D Method	U.S. SUGAR CLEWISTON MILL AND REFINERY	Boiler 7 - 385,000 lb/hr steam rate (1-hr max.)
357 Deleted - 20D Method	FT PIERCE UTIL/D KING PWR PLNT	37.5 MW Boiler Unit #7 (Phase II Acid Rain Unit)
358 Deleted - 20D Method	TOM G. SMITH POWER PLANT	COMBINED CYCLE UNIT (GT-2/S-5)
359 Deleted - 20D Method	CITY OF VERO BEACH MUNICIPAL UTILITIES	Fossil Fuel Steam Generator Unit No.2
360 Deleted - 20D Method	CITY OF VERO BEACH MUNICIPAL UTILITIES	Fossil Fuel Steam Generator Unit 4 (Phase II Acid Rain Unit)
361 Deleted - 20D Method	PRATT & WHITNEY AIRCRAFT	Ten existing jet engine test stands located in Test Area A
362 Deleted - 20D Method	SUGAR CANE GROWERS CO-OP	BOILER #4 WITH 2 SCRUBBERS AND 1 STACK
363 Deleted - 20D Method	SPWMD PUMP STATION S-5A	Six - 1600 hp diesel engines powering flood control pumps
364 Deleted - 20D Method	SOLID WASTE AUTHORITY OF PBC/NCRFF	Municipal Solid Waste Boiler #1
365 Deleted - 20D Method	SOLID WASTE AUTHORITY OF PBC/NCRFF	Municipal Solid Waste boiler #2
366 Deleted - 20D Method	FT PIERCE UTIL/D KING PWR PLNT	23.4 MW CCGT with 8.2 MW HRSG Unit # 9
367 Deleted - 20D Method	FT PIERCE UTIL/D KING PWR PLNT	56.1 MW Boiler Unit #8 (Phase II Acid Rain Unit)
368 Deleted - 20D Method	FT PIERCE UTIL/D KING PWR PLNT	56.1 MW Boiler Unit #8 (Phase II Acid Rain Unit)
369 Deleted - 20D Method	TOM G. SMITH POWER PLANT	GAS TURBINE # 1
370 Deleted - 20D Method	CITY OF VERO BEACH MUNICIPAL UTILITIES	Fossil Fuel Steam Generator Unit 4 (Phase II Acid Rain Unit)
371 Deleted - Duplicate Entry	MARTIN POWER PLANT	Combustion Turbine with HRSG (CT 3B)(Acid Rain, Phase II)
372 Deleted - Duplicate Entry	MARTIN POWER PLANT	Combustion Turbine with HRSG (CT 4A)(Acid Rain, Phase II)
373 Deleted - Duplicate Entry	MARTIN POWER PLANT	Combustion Turbine with HRSG (CT 4B)(Acid Rain, Phase II)
374 Deleted - Duplicate Entry	MARTIN POWER PLANT	Combustion Turbine with HRSG (CT 3A)(Acid Rain, Phase II)
375 Deleted - Duplicate Entry	MARTIN POWER PLANT	Fossil Fuel Fired Steam Generator #1(Acid Rain, Phase II)
376 Deleted - Duplicate Entry	MARTIN POWER PLANT	Fossil Fuel Fired Steam Generator #2(Acid Rain, Phase II)
377 Deleted - Duplicate Entry, modeled worst case	RIVIERA POWER PLANT	Fossil Fuel Steam Generator, Unit 3 -Phase II Acid Rain Unit
378 Deleted - Duplicate Entry, modeled worst case	RIVIERA POWER PLANT	Fossil Fuel Steam Generator, Unit 4 -Phase II Acid Rain Unit
379 Deleted - Modeled in Site Inventory	BERMAN ROAD LANDFILL	3000 SCFM. OPEN FLARE, MODEL 1493 (USED AS BACKUP)
380 Deleted - Modeled in Site Inventory	BERMAN ROAD LANDFILL	3000 SCFM. ENC FLARE, MODEL 1776 EVAP 3016
381 Deleted - Modeled in Site Inventory	BERMAN ROAD LANDFILL	3000 SCFM. ENC FLARE, MODEL 1688 EVAP 3001AM

Middle of Sources 530167.4 (m) East 3023733 (m) North
 AOI (km)
 AOI + 50km 50000 (m)

FACILITY ID	PSD Source?	OWNER/COMPANY NAME	SITE NAME	STATUS	ZONE	NORTH (km)	EAST (km)
0810029	no	CITY OF VERO BEACH	CITY OF VERO BEACH MUNICIPAL UTILITIES	A	17	3056.5	561.4
0550018	no	TAMPA ELECTRIC COMPANY	PHILLIPS STATION	A	17	3035.4	464.3
0550018	no	TAMPA ELECTRIC COMPANY	PHILLIPS STATION	A	17	3035.4	464.3
0850102	yes	INDIANTOWN COGENERATION, L.P.	INDIANTOWN COGENERATION PLANT	A	17	2990.7	547.65
0850001	yes	FLORIDA POWER & LIGHT (PMR)	MARTIN POWER PLANT	A	17	2992.65	542.68
0850001	yes	FLORIDA POWER & LIGHT (PMR)	MARTIN POWER PLANT	A	17	2992.65	542.68
0850001	yes	FLORIDA POWER & LIGHT (PMR)	MARTIN POWER PLANT	A	17	2992.65	542.68
0850001	yes	FLORIDA POWER & LIGHT (PMR)	MARTIN POWER PLANT	A	17	2992.65	542.68
0990042	no	FLORIDA POWER & LIGHT (PRV)	RIVIERA POWER PLANT	A	17	2960.62	593.27
0990042	no	FLORIDA POWER & LIGHT (PRV)	RIVIERA POWER PLANT	A	17	2960.62	593.27
0850001	no	FLORIDA POWER & LIGHT (PMR)	MARTIN POWER PLANT	A	17	2992.65	542.68
0850001	no	FLORIDA POWER & LIGHT (PMR)	MARTIN POWER PLANT	A	17	2992.65	542.68

EU ID	EU DESCRIPTION	EU STATUS	STACK HT (ft)	DIAM (ft)	EXIT TEMP (F)	ACFM	VEL (ft/s)	POLLUTANT
3	Fossil Fuel Steam Generator Unit 3 (Phase II Acid Rain Unit)	A	200	6	342	116375	68.6	NOX
1	19.535 MW SLOW SPEED DIESEL GENERATING UNIT 1	A	150	6	335	134500	79	NOX
2	19.535 MW SLOW SPEED DIESEL GENERATING UNIT 2	A	150	6	350	135500	79	NOX
1	Pulverized Coal Main Boiler	A	213.25	16	140	1123700	93.2	NOX
3	Combustion Turbine with HRSG (CT 3A)(Acid Rain, Phase II)	A	213	20	280	2420307	128.4	NOX
4	Combustion Turbine with HRSG (CT 3B)(Acid Rain, Phase II)	A	213	20	280	2420307	128.4	NOX
5	Combustion Turbine with HRSG (CT 4A)(Acid Rain, Phase II)	A	213	20	280	2420307	128.4	NOX
6	Combustion Turbine with HRSG (CT 4B)(Acid Rain, Phase II)	A	213	20	280	2420307	128.4	NOX
3	Fossil Fuel Steam Generator, Unit 3 -Phase II Acid Rain Unit	A	213.25	16	263	1063401	88.2	NOX
4	Fossil Fuel Steam Generator, Unit 4 -Phase II Acid Rain Unit	A	213.25	16	263	1052646	87.3	NOX
1	Fossil Fuel Fired Steam Generator #1(Acid Rain, Phase II)	A	213.25	36	338	2634519	43.1	NOX
2	Fossil Fuel Fired Steam Generator #2(Acid Rain, Phase II)	A	213.25	36	338	2634519	43.1	NOX

Potential (lb/hr)	Potential (tpy)	Allowable (lb/hr)	Allowable (tpy)	Comments
222.7	975.3			
571.8	2504.5	571.8	2504.5	
571.82	2504.5	571.82	2504.5	
582	2549	582	2549	Basis for allowable emission: PSD-FL-168. Emission limit based on 24 hr daily block average (midnight to midnight).
461	3108	177	3108	While burning natural gas. TYP represent the total allowed for fuel oil and natural gas. Basis for allowable: PSD-FL-146
461	3108	177	3108	While burning natural gas. TYP represent the total allowed for fuel oil and natural gas. Basis for allowable: PSD-FL-146
461	3108	177	3108	While burning natural gas. TYP represent the total allowed for fuel oil and natural gas. Basis for allowable: PSD-FL-146
461	3108	461	3108	While burning fuel oil. TYP represent the total allowed for fuel oil and natural gas. Basis for allowable: PSD-FL-146
1891	8282.58	1891	8282.58	While firing fuel oil.
1891	8282.58	1891	8282.58	While firing fuel oil.
2595	11366.1	2595	11366	While burning fuel oil. Co-firing of NG and FO shall be prorated see permit condition A10.
2595	11366.1	2595	11366	While burning fuel oil. Co-firing of NG and FO shall be prorated see permit condition QA10.

Distance (m)	20D Tons/Distance	Include in Inventory?
45267.5556	21.54523227	Yes
66892.6997	37.44055796	
66892.6997	37.44055796	Yes
37374.0604	68.20238347	Yes
33506.9851	92.75677876	Yes
33506.9851	92.75677876	Yes
33506.9851	92.75677876	Yes
33506.9851	92.75677876	Yes
89247.907	92.8041932	Yes
89247.907	92.8041932	Yes
33506.9851	339.2128531	Yes
33506.9851	339.2128531	Yes

Middle of Sources 530451.8 (m) East
 AOI 2.6 (km)
 AOI + 50km 52600 (m)

3023781 (m) North

PSD Source?	NORTH (km)	EAST (km)	EU ID	EU DESCRIPTION	EU STATUS	STACK HT (ft)	DIAM (ft)	EXIT TEMP (F)	ACFM
no	3035.3	561.4	1	Fossil Fuel Steam Generator Unit 3 (Phase II Acid Rain Unit)	A	200	6	342	118375
no	3035.4	464.3	2	19.535 MW SLOW SPEED DIESEL GENERATING UNIT 1	A	150	6	335	134500
no	3035.4	464.3	3	19.535 MW SLOW SPEED DIESEL GENERATING UNIT 2	A	150	6	350	135500
yes	2990.7	547.65	4	Pulverized Coal Main Boiler	A	213.25	16	140	1123700
yes	2992.65	542.68	5	Combustion Turbine with HRSG (CT 3A)(Acid Rain, Phase II)	A	213	20	280	2420307
yes	2992.65	542.68	6	Combustion Turbine with HRSG (CT 3B)(Acid Rain, Phase II)	A	213	20	280	2420307
yes	2992.65	542.68	7	Combustion Turbine with HRSG (CT 4A)(Acid Rain, Phase II)	A	213	20	280	2420307
yes	2992.65	542.68	8	Combustion Turbine with HRSG (CT 4B)(Acid Rain, Phase II)	A	213	20	280	2420307
no	2960.62	593.27	9	Fossil Fuel Steam Generator, Unit 3 -Phase II Acid Rain Unit	A	213.25	16	263	1063401
no	2960.62	593.27	10	Fossil Fuel Steam Generator, Unit 4 -Phase II Acid Rain Unit	A	213.25	16	263	1062846
no	2992.65	542.68	11	Fossil Fuel Fired Steam Generator #1(Acid Rain, Phase II)	A	213.25	36	338	2634519
no	2992.65	542.68	12	Fossil Fuel Fired Steam Generator #2(Acid Rain, Phase II)	A	213.25	36	338	2634519

NAAQS Sources

Scenario 2 - NAAQS - Annual

Source ID	Source Description	Easting (X) (m)	Northing (Y) (m)	Base Elevation (m)	Stack Height (ft)	Temperature (°F)	Exit Velocity (fps)	Stack Diameter (ft)	NOx (lb/hr)
1	Fossil Fuel Steam Generator Unit 3 (Phase II Acid Rain Unit)	561400	3056500	60.96	200	342	68.6	6	222.67
4	Pulverized Coal Main Boiler	547650	2990700	65.00	213.25	140	93.2	16	581.96
5	Combustion Turbine with HRSG (CT 3A)(Acid Rain, Phase II)	542680	2992650	65.00	213	280	128.4	20	709.59
6	Combustion Turbine with HRSG (CT 3B)(Acid Rain, Phase II)	542680	2992650	65.00	213	280	128.4	20	709.59
7	Combustion Turbine with HRSG (CT 4A)(Acid Rain, Phase II)	542680	2992650	65.00	213	280	128.4	20	709.59
8	Combustion Turbine with HRSG (CT 4B)(Acid Rain, Phase II)	542680	2992650	65.00	213	280	128.4	20	709.59
11	Fossil Fuel Fired Steam Generator #1(Acid Rain, Phase II)	542680	2992650	65.00	213.25	338	43.1	36	2595.00
12	Fossil Fuel Fired Steam Generator #2(Acid Rain, Phase II)	542680	2992650	65.00	213.25	338	43.1	36	2595.00

Scenario 2 - PSD - Annual

Source ID	Source Description	Easting (X) (m)	Northing (Y) (m)	Base Elevation (m)	Stack Height (ft)	Temperature (°F)	Exit Velocity (fps)	Stack Diameter (ft)	SO2 (lb/hr)
4	Pulverized Coal Main Boiler	547650	2990700	65.00	213.25	140	93.2	16	581.9634703
5	Combustion Turbine with HRSG (CT 3A)(Acid Rain, Phase II)	542680	2992650	65.00	213	280	128.4	20	709.5890411
6	Combustion Turbine with HRSG (CT 3B)(Acid Rain, Phase II)	542680	2992650	65.00	213	280	128.4	20	709.5890411
7	Combustion Turbine with HRSG (CT 4A)(Acid Rain, Phase II)	542680	2992650	65.00	213	280	128.4	20	709.5890411
8	Combustion Turbine with HRSG (CT 4B)(Acid Rain, Phase II)	542680	2992650	65.00	213	280	128.4	20	709.5890411

VEL (ft/s)	Potential (lb/yr)	Potential (tpy)	Allowable (lb/yr)	Allowable (tpy)	Distance (m)	200 Tons/Distance	Include in Inventory?
66.6	222.7	975.3			45036.91868	21.65556678	Yes
79	571.8	2504.5	571.8	2504.5	67164.43854	37.28907819	
79	571.82	2504.5	571.82	2504.5	67164.43854	37.28907819	
93.2	582	2549	582	2549	37284.4558	68.36629221	Yes
128.4	481	3108	177	3108	33446.49513	92.92453479	Yes
128.4	481	3108	177	3108	33446.49513	92.92453479	Yes
128.4	481	3108	177	3108	33446.49513	92.92453479	Yes
128.4	401	3108	481	3108	33446.49513	92.92453479	Yes
88.2	1891	8282.58	1891	8282.58	89081.0764	92.97799639	
87.3	1891	8282.58	1891	8282.58	89081.0764	92.97799639	
43.1	2585	11368.1	2585	11368	33446.49513	339.8263393	Yes
43.1	2585	11368.1	2585	11368	33446.49513	339.8263393	Yes

Middle of Sources 530433.1 (m) East

3023864 (m) North

AOI 1.1 (km)

AOI + 50km 51100 (m)

PSD Source?	NORTH (km)	EAST (km)	EU ID	EU DESCRIPTION	EU STATUS	STACK HT (ft)	DIAM (ft)	EXIT TEMP (F)	ACFM
no	3056.5	561.4	1	Fossil Fuel Steam Generator Unit 3 (Phase II Acid Rain Unit)	A	200	6	342	118375
no	3035.4	464.3	2	19.535 MW SLOW SPEED DIESEL GENERATING UNIT 1	A	150	6	335	134500
no	3035.4	464.3	3	19.535 MW SLOW SPEED DIESEL GENERATING UNIT 2	A	150	6	350	135500
yes	2990.7	547.65	4	Pulverized Coal Main Boiler	A	213.25	16	140	1123700
yes	2992.65	542.68	5	Combustion Turbine with HRSG (CT 3A)(Acid Rain, Phase II)	A	213	20	290	2420307
yes	2992.65	542.68	6	Combustion Turbine with HRSG (CT 3B)(Acid Rain, Phase II)	A	213	20	280	2420307
yes	2992.65	542.68	7	Combustion Turbine with HRSG (CT 4A)(Acid Rain, Phase II)	A	213	20	280	2420307
yes	2992.65	542.68	8	Combustion Turbine with HRSG (CT 4B)(Acid Rain, Phase II)	A	213	20	280	2420307
no	2960.62	593.27	9	Fossil Fuel Steam Generator, Unit 3 -Phase II Acid Rain Unit	A	213.25	16	263	1063401
no	2960.62	593.27	10	Fossil Fuel Steam Generator, Unit 4 -Phase II Acid Rain Unit	A	213.25	16	263	1062646
no	2992.65	542.68	11	Fossil Fuel Fired Steam Generator #1(Acid Rain, Phase II)	A	213.25	36	338	2634510
no	2992.65	542.68	12	Fossil Fuel Fired Steam Generator #2(Acid Rain, Phase II)	A	213.25	36	338	2634510

NAAQS Sources

Scenario 2A - NAAQS - Annual

Source ID	Source Description	Easting (X) (m)	Northing (Y) (m)	Base Elevation (m)	Stack Height (ft)	Temperature (°F)	Exit Velocity (fps)	Stack Diameter (ft)	NOx (lb/hr)
1	Fossil Fuel Steam Generator Unit 3 (Phase II Acid Rain Unit)	561400	3056500	60.96	200	342	68.6	6	222.67
4	Pulverized Coal Main Boiler	547650	2990700	65.00	213.25	140	93.2	16	581.96
5	Combustion Turbine with HRSG (CT 3A)(Acid Rain, Phase II)	542680	2992650	65.00	213	280	128.4	20	709.59
6	Combustion Turbine with HRSG (CT 3B)(Acid Rain, Phase II)	542680	2992650	65.00	213	280	128.4	20	709.59
7	Combustion Turbine with HRSG (CT 4A)(Acid Rain, Phase II)	542680	2992650	65.00	213	280	128.4	20	709.59
8	Combustion Turbine with HRSG (CT 4B)(Acid Rain, Phase II)	542680	2992650	65.00	213	280	128.4	20	709.59
11	Fossil Fuel Fired Steam Generator #1(Acid Rain, Phase II)	542680	2992650	65.00	213.25	338	43.1	36	2595.00
12	Fossil Fuel Fired Steam Generator #2(Acid Rain, Phase II)	542680	2992650	65.00	213.25	338	43.1	36	2595.00

Scenario 2A - PSD - Annual

Source ID	Source Description	Easting (X) (m)	Northing (Y) (m)	Base Elevation (m)	Stack Height (ft)	Temperature (°F)	Exit Velocity (fps)	Stack Diameter (ft)	SO2 (lb/hr)
4	Pulverized Coal Main Boiler	547650	2990700	65.00	213.25	140	93.2	16	581.9634703
5	Combustion Turbine with HRSG (CT 3A)(Acid Rain, Phase II)	542680	2992650	65.00	213	280	128.4	20	709.5890411
6	Combustion Turbine with HRSG (CT 3B)(Acid Rain, Phase II)	542680	2992650	65.00	213	280	128.4	20	709.5890411
7	Combustion Turbine with HRSG (CT 4A)(Acid Rain, Phase II)	542680	2992650	65.00	213	280	128.4	20	709.5890411
8	Combustion Turbine with HRSG (CT 4B)(Acid Rain, Phase II)	542680	2992650	65.00	213	280	128.4	20	709.5890411

VEL (ft/s)	Potential (lb/hr)	Potential (tpy)	Allowable (lb/hr)	Allowable (tpy)	Distance (m)	200 Tons/Distance	Include in Inventory?
68.6	222.7	975.3			44989.52535	21.67837941	Yes
79	571.8	2504.5	571.8	2504.5	67131.70794	37.30725877	
79	571.82	2504.5	571.82	2504.5	67131.70794	37.30725877	
93.2	582	2549	582	2549	37366.73041	68.21576231	Yes
128.4	461	3108	177	3108	33530.58836	92.69148417	Yes
128.4	461	3108	177	3108	33530.58836	92.69148417	Yes
128.4	461	3108	177	3108	33530.58836	92.69148417	Yes
128.4	461	3108	481	3108	33530.58836	92.69148417	Yes
88.2	1891	8282.58	1891	8282.58	89153.1241	82.90285768	
87.3	1891	8282.58	1891	8282.58	89153.1241	82.90285768	
43.1	2595	11368.1	2595	11368	33530.58836	338.9740698	Yes
43.1	2595	11368.1	2595	11368	33530.58836	338.9740698	Yes

South Florida Environmental Services

EMISSIONS COMPLIANCE TEST REPORT

PREPARED FOR:

Okeechobee landfill, Inc.
10800 NE 128th Avenue
Okeechobee, Florida 34972

CONCERNING:

Two Enclosed Flare Systems
Emission Units 003 & 005
10800 128th Avenue
Okeechobee, FL 34972

PREPARED BY:

South Florida Environmental Services, LLC
2257 Vista Parkway North, Suite 25
West Palm Beach, FL 33411

I hereby certify that the information contained in this report is true and accurate to the best of my knowledge:



Francis K Morlu

Project Manager

9/25/06
Date

CONTENTS

1.0 INTRODUCTION	1-1
1.1 Overview	1-1
1.2 Project Scope.....	1-1
1.3 Report Organization.....	1-2
1.4 Results & Conclusions.....	1-2
1.5 Test Schedule	1-2
2.0 PROCESS DESCRIPTION	2-1
2.1 General.....	2-1
2.2 Flare/Leachate E-VAP® Units.....	2-1
2.3 Process Data.....	2-1
3.0 SAMPLING LOCATIONS	3-1
3.1 Enclosed Landfill Thermal Flare Inlet.....	3-1
3.2 Enclosed Landfill Gas Enclosed Flare Outlet	3-1
3.2.1 Oxygen.....	3-1
3.2.2 Carbon Dioxide	3-2
3.2.3 Carbon Monoxide	3-2
3.2.4 Moisture Determination	3-2
3.3 CEMS Sampling System Description	3-3
3.3.1 Sample Delivery and Conditioning System	3-3
3.3.2 Calibration System	3-4
3.3.3 Data Acquisition System	3-4

4.0 QUALITY ASSURANCE/QUALITY CONTROL..... 4-5

- 4.1 Overview 4-5
- 4.2 CEMS QA..... 4-5
 - 4.2.1 Calibration Gases 4-5
 - 4.2.2 Instrumental Monitoring..... 4-5
 - 4.2.3 Sampling Setup 4-6
 - 4.2.4 Calibration Criteria 4-6
 - 4.2.5 Calibration Drift and System Bias Correction..... 4-7
- 4.3 Methods Equipment Calibrations 4-7

LIST OF TABLES

Table 1-1 Test Program Informational Summary	1-3
Table 1-2 Test Summary – Enclosed Thermal Flare Outlets	1-4
Table 1-3 Summary of Emission Unit 003 Test Results	1-4
Table 1-4 Summary of Emission Unit 005 Test Results	1-5
Table 1-5 Compliance Emission Test Schedule	1-5
Table 3-1 CEM Instrument Ranges and Calibration Gases	3-3

APPENDICES

- A Field Data Sheets
- B Calculation Sheets
- C Gas Cylinder Certifications
- D Nomenclature
- E Meterbox Calibration Sheets

1.0 INTRODUCTION

1.1 Overview

Eastmount / South Florida Environmental Services, of West Palm Beach, FL was retained by Okeechobee Landfill, Inc. (OLI) of Okeechobee, Florida to conduct an emissions compliance test program at the OLI landfill. The Test was conducted on the two LFG Specialties enclosed landfill gas flares systems operating at the facility (E. U. 003 and E. U. 005)

The test program was carried out to satisfy the conditions of the facility's air pollution permit (Permit Number: 0930104-011-AV) issued by the State of Florida Department of Environmental Protection (FDEP). The testing was conducted over a two-day period August 28 and 29, 2006. A summary of the primary parties involved in this test program is presented in Table 1-1.

The objective of the program was to determine the compliance status of the LFG Specialties Enclosed Landfill gas flare/EVAP systems with respect to the limits set forth in the Air Pollution Permit and the requirements of the MSW Landfill New Source Performance Standards (NSPS). Compliance determinations were conducted on the outlets of the enclosed flares (E. U. 003 and E. U. 005). This consisted of sampling for carbon monoxide (CO) emissions while the enclosed flares were being fueled by landfill gas only. Other measurements taken during each compliance sampling run included the determination of flue gas temperature, moisture, oxygen and carbon dioxide.

1.2 Project Scope

All sampling during this compliance test program was conducted in accordance with the test methods and sampling procedures set forth in 40 CFR 60, Appendix A. In addition, the sampling program was conducted in accordance with the FDEP emission test guidelines and the methods and test procedures set forth in the Test Protocol that was submitted last year. Additionally, measurement for methane and flow at the inlet for both flares were taken with the help of the facility's instrumentation.

1.3 Report Organization

The remainder of this report is organized into three additional Sections. Section 2 provides a description of the enclosed landfill gas flare/EVAP systems. Section 3 presents a description of the sampling locations for the sources tested. A description of all test methods and analytical procedures is provided in Section 3, while Section 4 addresses the quality assurance/quality control aspects of the program. Field data sheets, emission calculation spreadsheets and equipment calibrations are included in the appendices.

1.4 Results & Conclusions

Table 1-2 indicates the EPA sampling methods and the FDEP and NSPS emission limits that were applied in order to satisfy the sampling requirements set forth by the Air Permit. Table 1-3 and Table 1-4.2 provide summaries of the emission test results from E. U. 003 and E. U. 005. These results indicate that the CO emissions from both E. U. 003 and E. U. 005 at the Okeechobee landfill are well below the permit limit of **0.27 lb/MMBtu**.

1.5 Test Schedule

The compliance test program was carried out over a three-day period. This included one day for set-up Day 1. Compliance Sampling on E. U. 003 and E. U. 005 was conducted on the second and third days respectively. Table 1-5 shows the schedule for the compliance test program.

Table 1-1 Test Program Informational Summary

Source Information	
Facility Name:	Okeechobee Landfill, Inc
Address:	10800 NE 128 th Avenue Okeechobee, Florida 34972
Contact:	Mr. Miguel Delgado
Title:	Engineering Manager
Phone:	863.763.4818
Test Firm Information	
Test Organization:	South Florida Environmental Services
Address:	2257 Vista Parkway Unit 25 West Palm Beach, FL 33411
Contact:	Mr. Francis K Morlu
Title:	Project Manager
Phone:	561.687.5300
State Information	
Organization:	Florida DEP – Southeast District
Address:	200 N. Congress Ave., Suite 200 West Palm Beach, FL 33401
Contact:	Mr. Stan Ganthier
Title:	Compliance Engineer
Phone:	(561) 681-6627

Table 1-2 Test Summary – Enclosed Thermal Flare Outlets

Fuel Type(s)	Parameter	EPA Method	No. Of Runs	Run Duration	FDEP Limit
Landfill Gas	CO	10	3	60-minutes	0.27 lb/MMBtu ⁽¹⁾
	O ₂ and CO ₂	3A	3	60-minutes	NA
	Moisture	4	3	60-minutes	NA

Table 1-3

Waste Management, Incorporated - Okeechobee Landfill Summary of Compliance Emission Test Results Air Emission Test Program - Emission Unit #003						
Date		28-Aug-06	28-Aug-06	28-Aug-06		
Run I.D.		Test-1	Test-2	Test-3		
Start Time		11:30	12:38	13:45		
End Time		12:30	13:38	14:45	Average	
Stack Temp	(°F)	1631.0	1631.8	1631.9	1631.6	
Moisture	% by Vol	18.2	21.8	18.0	19.3	
Stack Flow	DSCFM	16357	16330	16357	16347.7	
Oxygen	(%)	10.78	10.58	10.67	10.68	Permit Limits
Carbon Dioxide	(%)	9.56	9.56	9.50	9.54	
CO	ppmdv	13.70	21.85	26.08	20.54	0.270
	Lb/MMBTu	0.017	0.026	0.032	0.025	
Process Data						
Temperature	°F	1632	1630	1630	1630	
Fuel Flow	scfm	2562	2824	2811	2732	
Fuel HHV	BTU/scf	490	490	490	490	
Methane	(%)	51	49	1632	577	
$\text{Lb/MMBTu} = \text{ppm} \times \text{mw} / 383 \quad 3 / 1,000,000 \times \text{Fd} \times (20.9 / 20.9 - \text{O}_2)$ mw = 28.01						
Note: The average Fd-Factor (8144) and Heat value (Fuel HHV - BTU/scf) were taken from last years fuel analysis of this site.						

Table 1-4

Waste Management, Incorporated - Okeechobee Landfill Summary of Compliance Emission Test Results Air Emission Test Program - Emission Unit #005						
Date		29-Aug-06	29-Aug-06	29-Aug-06		
Run I.D.		Test-1	Test-2	Test-3		
Start Time		8:45	9:50	10:59		
End Time		9:45	10:50	11:59	Average	
Stack Temp	(*F)	1647	1646	1646	1646.3	
Moisture	% by Vol	26.9	24.6	21.2	24.2	
Stack Flow	DSCFM	16267	16305	16363	16311.7	
Oxygen	(%)	9.04	10.16	10.25	9.82	Permit Limits
Carbon Dioxide	(%)	11.37	10.27	10.66	10.76	
CO	ppmdv	36.01	26.74	12.96	25.24	0.270
	Lb/MMBTu	0.038	0.031	0.015	0.028	
Process Data						
Temperature	*F	1643	1653	1653	1650	
Fuel Flow	scfm	2026	2011	1999	2012	
Fuel HHV	BTU/scf	490	490	490	490	
Methane	(%)	37	35	48	40	
$\text{Lb/MMBTu} = \text{ppm} \times \text{mw} / 383.3 / 1,000,000 \times \text{Fd} \times (20.9 / 20.9 - \text{O}_2)$					mw = 28.01	
Note: The average Fd-Factor (8144) and Heat value (Fuel HHV - BTU/scf) were taken from last years fuel analysis of this site.						

Table 1-5 Compliance Emission Test Schedule

Emission Units Tested	Date & Time
Set-up on Emission Unit 003	August 23, 2006
Emission Unit 003	August 28, 2006 (8:45 am to 11:58 am)
Emission Unit 005	August 29, 2006 (11:32 am to 2:47 pm)

Appendix D

Best Available Control Technology (BACT) Analysis

TABLE OF CONTENTS

1.0	Best Available Control Technology Analysis	1
2.0	BACT: SO ₂	2
2.1	USEPA Technology Clearinghouse Database for SO ₂	2
2.2	SO ₂ Control Technologies	3
2.3	Overview of SO ₂ Control Technologies	3
2.4	SO ₂ Control Technology Descriptions	4
2.4.1	LO-CAT® or Mini-CAT	4
2.4.2	Sulfur-Rite®	4
2.4.3	Sulfa Treat	4
2.4.4	Sulfa Bind	5
2.4.5	Biopuric	5
2.4.6	Thiopaq	5
2.4.7	H2SPLUS	6
2.4.8	Enviro-Scrub®	6
2.4.9	Enviro-Tek™	6
2.4.10	Biotrickling Filter	7
2.4.11	Off-Site Power Generation Plant	7
2.5	SO ₂ Control Technology Analysis	8
2.6	SO ₂ BACT Selection	9
3.0	BACT: NO ₂	14
3.1	USEPA Technology Clearinghouse Database for NO ₂	14
3.2	Overview of NO _x Control Technologies	15
3.3	NO _x Control Technology Descriptions	15
3.3.1	Combustion Modification	15
3.3.1.1	Staged Combustion	15
3.3.1.2	Catalytic Combustion	16
3.3.1.3	Diluent Injection	16
3.3.2	Post-Combustion Control	17
3.3.2.1	SNCR	17
3.3.2.2	SCONOX™	17
3.3.2.3	SCR	17
3.4	NO ₂ Control Technology Analysis	18
3.5	NO ₂ BACT Selection	18
3.5.1	Combustion Turbines	18
3.5.2	Flares	19
4.0	BACT: CO	19
4.1	USEPA Technology Clearinghouse Database for CO	19
4.2	Overview of CO Control Technologies	20
4.3	CO Control Technology Descriptions	20
4.3.1	Combustion Control	20
4.3.2	Post Combustion Catalytic Controls	21
4.3.3	Combustion Design	21
4.3.4	Post combustion catalytic controls	22
4.4	CO Control Technology Analysis	22
4.5	CO BACT Selection	22
5.0	BACT: PM ₁₀	22
5.1	USEPA Technology Clearinghouse Database for PM ₁₀	22
5.2	Overview of PM ₁₀ Control Technologies	23
5.3	PM ₁₀ Control Technology Descriptions	24
5.3.1	Combustion Control	24

5.3.2	Post-Combustion Controls	24
5.4	PM ₁₀ Control Technology Analysis.....	24
5.5	PM ₁₀ BACT Selection	24

1.0 Best Available Control Technology Analysis

Under Florida's Preconstruction Review Process (PCR), a PSD permit process requires a BACT analysis in order to identify the pollution control device or system that is most suitable with respect to technological and economic considerations [F.A.C. 62-212.400(4)(c)]. The code defines and provides the general approach to support a BACT analysis under Definitions [F.A.C. 62-210.200(39)].

- (a) *An emission limitation, including a visible emissions standard, based on the maximum degree of reduction of each pollutant emitted which the Department, on a case by case basis, taking into account:*
 - 1. *Energy, environmental and economic impacts, and other costs;*
 - 2. *All scientific, engineering, and technical material and other information available to the Department; and*
 - 3. *The emission limiting standards or BACT determinations of Florida and any other state; determines (what) is achievable through application of production processes and available methods, systems and techniques (including fuel cleaning or treatment or innovative fuel combustion techniques) for control of each such pollutant.*
- (b) *If the Department determines that technological or economic limitations on the application of measurement methodology to a particular part of an emissions unit or facility would make the imposition of an emission standard infeasible, a design, equipment, work practice, operational standard or combination thereof, may be prescribed instead to satisfy the requirement for the application of BACT. Such standard shall, to the degree possible, set forth the emissions reductions achievable by implementation of such design, equipment, work practice or operation.*
- (c) *Each BACT determination shall include applicable test methods or shall provide for determining compliance with the standard(s) by means which achieve equivalent results.*
- (d) *In no event shall application of best available control technology result in emissions of any pollutant which would exceed the emissions allowed by any applicable standard under 40 CFR Parts 60, 61, and 63.*

The definition above describes a PCR project and how BACT is developed. This construction project and other MSW landfill projects are substantially different from most PCR processes. In most PCR projects the facility has not been built or it has been built and is operational but a definable expansion is proposed. In the case of an MSW landfill project, such as this, the facility has been permitted and construction is underway and will continue until the facility is completed. As the "community", the geographic area served by the waste disposal site, grows, the landfill will receive waste and fill the disposal site..

Historically agencies have looked at the flares or other combustion devices used to comply with requirements adopted under the Clean Air Act as emission sources along with the landfill and each control device was permitted as they were needed. In this permit application the landfill is the emission unit and the flares and gas turbines are the control devices associated with the emission unit. It is expected that up to a three year period will be necessary for permit approval, procurement, design and construction for the selected BACT control equipment prior to operation of the selected BACT equipment. Additionally, during the same period, the same process will be occurring for the LFGTE power plant.

2.0 BACT: SO₂

2.1 USEPA TECHNOLOGY CLEARINGHOUSE DATABASE FOR SO₂

A review was made of the USEPA RACT BACT LAER Clearinghouse by using the USE PA web site www.epa.gov/ttn/catc/rblc. The data base was searched for landfills with the pollutant SO₂. The results are summarized in **Table 2-1** below.

**Table 2-1
 USEPA TTN Database Search Parameters and Results for SO₂**

Process Information	Result
Fuel Combustion	
<i>Utility and Large Industrial Boiler/ Furnaces</i> 11.320 LF/ Digester/ Bio-gas	None
<i>Industrial Size Boilers/ furnaces (> 100 mi)</i> Gaseous fuel and mixtures 12.320 LF/ Digester/ Bio-Gas	None
<i>Commercial/ Industrial size boilers/ furnaces</i> Gaseous fuel and mixtures 13.320 LF/ Digester/ Bio-Gas	None
<i>Large combustion Turbines (> 25 MW)</i> Simple Cycle 15.120 LF/ Digester/ Bio-Gas	None
Combined Cycle and Co-generation 15.220 LF/ Digester/ Bio-Gas	None
<i>Small Combustion Turbines (<25 MW)</i> Simple Cycle 16.120 LF/ Digester/ Bio-Gas	None
Combined Cycle and Co-generation 16.220 LF/ Digester/ Bio-Gas	None
<i>Internal Combustion Engine</i> Large Internal Combustion Engine (> 500 HP) 17.140 LF/ Digester/ Bio-Gas	6 Facilities
Small Internal Combustion Engine 17.240 LF/ Digester/ Bio-Gas	1 Facility

Process Information	Result
Miscellaneous Combustion Flares 19.320 Digester & LF Gas Flares	6 Facilities Note: (one facility is beef processing and therefore not considered applicable)

2.2 SO₂ CONTROL TECHNOLOGIES

Further research into BACT technologies was made through known vendors and inquiries to others with technology which may be available to the project. The vendors contacted and the technologies of interest were as follows:

**Table 2-2
 Vendors for SO₂ Technologies**

Vendor Name	Technology Name
Q2	EnviroScrub
Q2	Enviro-Tek
Gas Technology Products LLC	LO-CAT®
Gas Technology Products LLC	Sulfur-Rite®
Natco Group	SulfaTreat
ADI	SulfaBind
Biothane Corp	Biopuric
Paques, Inc.	Thiopaq
Mtarri/Varani	H2SPlus
Shaw E&I, Inc.	Biotrickling Filter (BTF) system with FlexFil™ Media
Cogentrix	Off-site destination for co-generation project

Each of these technologies is further described in the paragraphs below.

2.3 OVERVIEW OF SO₂ CONTROL TECHNOLOGIES

Dry- and liquid-based chemical processes have traditionally been used for removing sulfur from various industrial process gas streams. These technologies include: activated carbon adsorption (often impregnated with ferric oxide); amine-based technology; caustic (liquid)-based technology; chlorine dioxide; metallic oxide-based technology; nitrite-based processes; and triazine-based chemical reagent processes. With the exception of metal oxide, none of the above are viewed as BACT-suitable for landfills. Metallic oxide-based technology involves using beds, slurries and powders that contain hydrated metal oxides that appear to be economical and effective in selectively removing H₂S from landfill gas streams. While initial investment and operator involvement is relatively low compared to other approaches, waste handling and disposal costs may be significant.

In the past few years, many chemical, physical and biological technologies have become available for the removal of H₂S from biogas and landfill gas streams. This BACT analysis evaluated such brand name chemical-physical systems as LO-CAT®, Mini-CAT™, Sulfa Treat™, and Sulfa Bind®. Sulfur-Rite® is a brand name, dry-based chemical system. Biological process technologies evaluated include Biopuric and Thiopaq, the latter involving both biological and chemical process units. In addition, H2SPLUS, a technology based on

iron sponge and biological processes, was also evaluated. These systems are described briefly below.

2.4 SO₂ CONTROL TECHNOLOGY DESCRIPTIONS

The information presented regarding these technologies was obtained from the manufacturers, internet-based research and technical papers.

2.4.1 LO-CAT® or Mini-CAT

LO-CAT® is an aerobic process to control hydrogen sulfide odors developed by Gas Technology Products, LLC, subsidiary of Merichem Company. The process uses a chelated iron catalyst to convert H₂S into elemental sulfur.

The LO-CAT® system consists of a venturi absorber and a mobile bed oxidizer. Landfill gas is treated in the absorber vessel by the iron catalyst, which is held in solution by organic chelating agents that form a film around the iron ions. The chelating agents prevent precipitation of either iron sulfide or iron hydroxide. In the absorber, H₂S is absorbed into a slightly alkaline aqueous solution. The H₂S ionizes to bisulfide, which is oxidized to sulfur by reducing the iron ion from ferric to ferrous state. The reduced ions are then transferred to the oxidizer, where the catalyst is regenerated. Atmospheric oxygen is absorbed into the LO-CAT® (similarly for the LO-CAT® Mini-Cat) solution to re-oxidize ferrous iron to ferric iron, hence regenerating the catalyst.

The overall reaction is an isothermal modified Claus reaction. The chemical additions required to maintain the above reactions are caustic for maintaining the pH, chelated iron, which is lost in the sulfur removal process, and chelating agents that are degraded in the process and need to be replaced. Thiosulfate and bicarbonates may form as side reactions to produce excess amounts of sour gas and carbon dioxide. Caustic is required to be added under such conditions to maintain the pH.

2.4.2 Sulfur-Rite®

Sulfur-Rite®, developed by Gas Products Technology, LLC, is a chemical process that converts H₂S into iron pyrite, a stable, non-hazardous compound.

This process consists of two vessels housing the iron-based media. Landfill gas enters the top of the vessel, traveling down through the media as it reacts with the iron. The spent media is non-regenerable and has to be replaced with new media on a periodic basis. The spent media is non-toxic and can generally be safely disposed of in a landfill.

2.4.3 Sulfa Treat

Sulfa Treat is a physico-chemical process, developed by the NATCO Group, featuring a black, granular, pea-sized dry iron compound that selectively removes H₂S.

This process consists of two vessels housing Sulfa Treat media with support trays and media loading and clean out pathways. This process is not affected by pressure variations and the unique characteristics of the media prevent channeling of the landfill gas stream. The media is non-regenerable and needs to be replaced once it is spent. The spent media is non-toxic and can be disposed of in a landfill. The process does not produce any undesirable off-gas and no foaming occurs during the

reaction. Since the media only reacts with sulfur-containing compounds, any side reaction with CO₂ that could reduce its efficiency, is eliminated.

2.4.4 Sulfa Bind

Sulfa Bind, developed by ADI Inc., is a physico-chemical technology that uses a diatomite media coated with ferric hydr oxide having a grain size of sand to remove H₂S.

The process includes four filter vessels housing the inorganic media, gravel support bed, inlet and outlet nozzles, a regeneration blower and associated piping and valves. The landfill gas is stripped of H₂S when it comes in contact with the media. The process operates with two filters at a time, while the other two are used when the media in the first two vessels is being regenerated. The media is regenerated by blowing air through the media for 8 to 12 hours. Approximately 12 regenerations are possible before the media needs to be replaced. The spent media is non-toxic and can be disposed in a municipal waste landfill.

This process is undergoing its first practical landfill application pilot test and has not yet been used on a full-scale basis at any landfill.

2.4.5 Biopuric

Biopuric is an anaerobic biological process to remove H₂S from gas streams developed by Biothane Corporation. This process uses H₂S removing bacteria to metabolize H₂S from gas streams and produce elemental sulfur.

Biopuric includes four scrubbers, recirculation pumps, and an air blower. The scrubbers house the biomass, which digest the H₂S gas. Biomass is media impregnated with bacterial "bio-film." The landfill gas is fed into the scrubber from the bottom, where contact with water transfers the H₂S from the gas stream into the liquid stream. The liquid is then circulated by pumps to be contacted with the biomass. The bacteria decompose H₂S to produce elemental sulfur. The nutrients required for the bacterial activity are supplied through the recirculation pumps.

This technology does not require any media change out. With proper operating conditions of moisture and pH, the bacteria can apparently thrive indefinitely. The media is required to be flushed periodically to remove built up elemental sulfur.

2.4.6 Thiopaq

The THIOPAQ process, developed by Paques, Inc., is a bio-chemical process for treatment of H₂S in industrial gas streams. This process consists of a caustic scrubber combined with a bioreactor in which the spent caustic solution is regenerated.

The gas enters a wet scrubber from the bottom, typically a packed column, and is desulfurized by contact with a slightly alkaline fluid, at pH 8 to 9 fed from the top. Clean gases leave the scrubber at the top, while scrubbed sulfide liquid collects at the bottom of the scrubber.

The spent scrubber liquid is collected in the bottom of the scrubber and directed to the bioreactor. In the bioreactor, *Thiobacillus* bacteria consume oxygen to convert the dissolved H₂S into solid elemental sulfur, thereby regenerating caustic soda present in the spent scrubber liquid. This sulfur depleted and caustic regenerated liquid is returned to the scrubber for renewed removal of H₂S. A small bleed stream is removed periodically from the scrubber to prevent built up of formed salts. This stream is non-hazardous and can in most cases easily be discharged.

Since there is a significant biological overcapacity in the reactor, variations in the H₂S loading rate can be handled. Caustic soda is added periodically to neutralize sulfuric acid which is a by-product of the H₂S scrubbing.

2.4.7 H2SPLUS

H2SPLUS is a physico-chemico-biological process, developed by Mtarri/Varani LLC, featuring iron sponge technology impregnated with biological agents that selectively removes odor emanating compounds such as H₂S, mercaptans, carbon disulfide and particulate matter.

This process consists of five fiber glass vessels housing iron sponge media with gas distribution piping, water recirculation piping, support trays and media loading and clean out pathways. The vessels are equipped with lifting nets to facilitate media replacement. A sump to collect condensate and recycle the leached iron oxide and sodium bicarbonate (if necessary) is located below the vessel. A small blower adds up to 3% by volume of ambient air to the inlet gas stream to maintain a lower explosive limit, regenerate the media, and facilitate the conversion of iron sulfide to elemental sulfur. When landfill gas is passed through the iron sponge media (wood chips impregnated with iron oxide), H₂S reacts with to form a pyretic-type iron sulfide compound hence immobilizing the H₂S. The biological agents react simultaneously with sulfur compounds to oxidize the pyrites and produce elemental sulfur while regenerating iron oxide.

The media is non-regenerable and needs to be replaced once it is spent. The spent media needs to be treated onsite by wetting and allowing air oxidation to occur over a four day period so that the material is not pyrophoric. The spent media is non-toxic and can be disposed of in a municipal waste landfill or composted and applied as a fertilizer in farming operations. The process does not produce any undesirable off-gas and no foaming occurs during the reaction. Since the media only reacts with sulfur-containing compounds, any side reaction with CO₂ that could reduce its efficiency is eliminated.

2.4.8 Enviro-Scrub®

Enviro-Scrub® is a physico-chemical process, developed by the Q² Technologies that is based upon sparging gas through the solution to remove the H₂S and mercaptans from hydrocarbon fluids, natural gas, gas streams, water and waste water streams. Enviro-Scrub® series of products are non-hazardous and react immediately with H₂S to produce a non-reversible, non-hazardous stable compound. The media is non-regenerable and needs to be disposed of and replaced once it is spent. The spent media is non-toxic, water soluble, forms no solids, is biodegradable and can be disposed of in a municipal waste landfill. The process does not produce any undesirable side reactions that cause the solution to be toxic or hazardous. The media yields minimal reactions with CO₂, increasing efficiency.

2.4.9 Enviro-Tek™

Enviro-Tek™ is a physico-chemical process, developed by the Q² Technologies, that utilizes the sulfur scrubbing mechanism of the Enviro-Scrub™ molecule, but may be regenerated to fresh product with aeration of the spent material in a batch or continuous flow process. Enviro-Tek™ is a patented process that selectively removes H₂S and mercaptans out of landfill gas, digester gas, natural gas, refinery flue gas and air collection systems. Enviro-Tek™, like Enviro-Scrub®, is non-toxic and non-corrosive. The Enviro-Tek™ process by-product consists of a granular elemental sulfur cake containing a small percentage of non-toxic, biodegradable Enviro-Tek™ solution. The system make-up requirement is limited to replacing

Enviro-Tek™ solution lost in removing elemental sulfur from the system. The spent media is non-toxic, water soluble, forms no solids, is biodegradable and can be disposed of in a municipal waste landfill. The process does not produce any undesirable side reactions that cause the solution to be toxic or hazardous. The media yields minimal reactions with CO₂, increasing efficiency. Once the H₂S monitor in the outlet reaches the breakthrough point, the spent chemical solution is removed and replaced with fresh chemical solution.

2.4.10 Biotrickling Filter

Shaw Environmental's Biotrickling Filter (BTF) system, utilizing FlexFil™ Media, is an innovative technology for this application. The system package removes contaminant chemicals, such as hydrocarbons and reduced sulfur compounds, from air streams. In the biotrickling filter bed, microbes are responsible for degrading and eliminating the contaminants. The FlexFil™ media is specially manufactured polyurethane foam that provides a maximum level of porosity and biological activity, low pressure drop, and a high level of physical stability and predictable long life.

A portion of the contaminants from the influent air are adsorbed on the surface of the media while the rest of the contaminants are absorbed into the thin film of water surrounding media particles. Microorganisms on the surface of the particles and in the water continuously metabolize the contaminants, converting them to water, carbon dioxide, and salts. Sulfur odors are reduced with the production of sulfate while ammonia and other nitrogen-containing compounds are treated with the generation of nitrate.

While passing through the media, the contaminants in the air stream are metabolized and removed. The purified air passes through the lower chamber of the biotrickling filter and out via a blower on the downstream of the system.

There are multiple media layers inside the Biotrickling filter. The quantity of layers depends on the size of the proposed unit. The layers include Shaw Environmental's proprietary irrigation systems, placed above each layer of the media, thereby assuring that moisture and nutrients are directed to the specific locations within the BTF where they will provide optimum benefit with minimum consumption of utilities. This irrigation system is also used to flush out accumulated salts and acids as required to maintain the performance of the biotrickling filter. Nutrient is added to the system via a nutrient injection system which delivers a nutrient solution to the system whenever the water fill valve is activated.

2.4.11 Off-Site Power Generation Plant

The use of an off-site power plant for transmission and beneficial use of the landfill gas is another alternative to on-site treatment for SO₂ reduction. Approximately 25 miles southeast of Okeechobee Landfill is a pulverized coal plant operated by Cogentrix. The plant has an air pollution control systems that may be able to handle, or with modifications be able to handle, the Okeechobee landfill gas with 5800 ppmv of H₂S and continue to meet their permitted allowable SO₂ emission limits of 0.170 lbs/MMBtu.

Transmitting the LFG to an off-site power plant for beneficial use was alternative to on-site SO₂ controls. Approximately 25 miles southeast of Okeechobee Landfill is a pulverized coal plant operated by Cogentrix. The permit for that plant was reviewed

and it appeared that control technology at the plant would be able to accept LFG with 5800 ppmv of H₂S. However, the evaluation of this alternative was not pursued any further because the estimated cost estimate to design, permit, construction the pipeline, and install retrofit air pollution controls was too high to be economically feasible.

Table 2-3

Pipeline Length: 25 miles	Cost: \$25,000,000 ¹
Retrofit the Cogentrix burners and boilers to accept LFG	Added burners:3 @\$3,000,000 each ²
LFG Acceptance Fee due to negative impact to coal burner.	Expected Fee but not available
Beneficial use of LFG to Applicant	None

Notes: ¹Estimate from Shaw Gas Pipeline Personnel, obtained in 2006

²Estimate from similar project involving a waste-to-energy plant, 2002.

2.5 SO₂ CONTROL TECHNOLOGY ANALYSIS

As of the date of this report, complete information for all the technologies was not made available by the vendors, although follow-up calls were made to the vendors to gather as much information as possible to complete the table. Capital costs and operating costs were obtained from the vendors for a landfill gas flow rate 9,000 scfm and a H₂S concentration of 5,800 ppm. Nine thousand (9,000) -scfm was used because that was the first assumption of the project scope. The final analysis is based on a per ton basis; therefore, the costs were then scaled up to the application flow rate.

The capital costs were annualized over ten years and combined with the annual operating costs. The exception is the gas transmission line project which is annualized over 30 years because this project would likely not be undertaken as a cost-benefit project unless the capital cost were over a longer period. Calculations were performed using the combined annualized capital and operating cost and the landfill gas parameter to estimate the cost per ton of SO₂ removed for each technology. **Table 4** provides a summary of the technology review. The table includes a brief description of the capital equipment and construction costs, the capital and annual costs, previous project applications, and the estimated removal performance limits for the various technologies.

Table 5 presents the ranking of the control technologies based on the following information:

- Has the technology been applied to landfills previously?
- Has the technology demonstrated an ability to handle the hydrogen sulfide levels anticipated from the landfill?
- What is the capital cost of the technology to handle to flow and Hydrogen sulfide levels at Okeechobee?
- What are the operating costs for the technology at the levels and flow anticipated at Okeechobee?
- Can the flow or hydrogen sulfide content be increased with modifications to the technology with ease?

- What are the energy costs, waste disposal costs, chemical costs and manpower requirements associated with the technology?

The following observations derive from the cost feasibility analysis presented in the above tables:

- All ten (10) combustion pre-treatment technologies claim to be able to meet the stated performance requirements, although vendors for Enviro-Scrub, Enviro-Tek, and Sulfa Treat admitted that their technologies could not treat the landfill gas at this site efficiently enough to be economically feasible.
- LO-CAT®, Sulfa Treat and Thiopaq all have direct landfill application experience.
- LO-CAT® and Biopuric have the lowest annualized costs.
- While Sulfa-Rite has the lowest capital costs, it has high annual costs and the highest annualized cost.
- Although Biopuric is an emerging technology with successful digester gas applications, its water consumption is very high and the wastewater disposal requirements, which were unaccounted for, are likely to be very significant for landfill applications.
- A final selection will consider several factors: total annualized cost, initial capital outlay and proven site-specific operating experience in order to estimate design-build level costs.
- Biofilter Trickling -
- Off-site Pipeline -

The technologies were ranked in order from 1 to 6 based on cost, treatment effectiveness, and previous successful applications; 1 being the most cost effective of the technologies reviewed. Technologies that were not feasible according to their respective vendors are labeled as "unavailable" in **Table 5**. The biofilter trickling system is an innovative technology that has not been used in production or in a pilot demonstration project and is therefore labeled as "Innovative/Unproven", which ranks before the unavailable technologies. The BACT analysis is based on the H₂S rate of 5,800 ppmv and any changes in these levels may affect the analysis outcome.

2.6 SO₂ BACT SELECTION

The technologies reviewed and compiled for the BACT analysis reflects state of the art technologies relative to sulfur dioxide control for landfill flares. The analysis is broad reaching in its search for less established technologies such as beneficial use and new biological processes, which, if successful, could be used to at other facilities interested in reducing SO₂ emissions. In general, the cost to reduce the SO₂ emissions from the landfill gas is expensive compared to the cost of SO₂ allowances available on the open market under the acid rain program in the United States. As reported by Evolution Markets, LLC. On July 27, the most recent sales of SO₂ allowances are \$652.50 per allowance on the open market.

According to current federal and state rules, the emissions of SO₂ are significant and may require reductions with the use of BACT. The two top ranked control technologies in this report: 1.) beneficial use in a power plant and 2.) LO-CAT®, need to be further analyzed in their feasibility versus cost. As part of this further analysis, the continued growth and operation of the landfill needs to be considered for the handling and control of landfill gas with high sulfur content. This BACT analysis was developed over a relatively short period to

meet the 30-day permit application submission requirement of the facility's consent decree. Since the BACT development period was expedited, additional information was not obtained to finalize the proposed BACT for the landfill flare. Additional information would include input from the power plant owners and operators for the beneficial use alternative and detailed design with consideration to water usage and waste water requirements for the LO-CAT® technology.

Selection of BACT for SO₂

After the BACT review and analysis for SO₂ BACT, LO-CAT®, was selected. Negotiations for acquisition of the equipment and design of the system will follow.

Table 2-4 Summary of Technologies and Parameters for BACT Analysis

Technologies	Description	Capital Cost Items	Capital Cost	Annual Cost Items	Annual O&M Cost	Annualized Cost (over 10 years)	Cost per Ton of SO ₂ Removed	Known Applications	Performance	Vendor Info	Comments or Notes
LO-CAT®	Consists of venturi absorbers and mobile bed absorber containing iron chelate solution.	Engineering Fabrication Initial Chemical Fill Licensing fees O&M Manuals Start up training costs Tax & FOB	\$5,000,000	Chemical costs Media Change outs Bag filters Electricity O&M Labor Media disposal	\$500,000	\$1,000,000	\$267.03	Pompano Beach LF, FL	98%	Gas technology Products David Graubard 847.285.3855	Application at Central landfill has had notable success.
Sulfur-Rite®	Split gas into six parallel streams 6 vessels, 17' dia and 22' high Each vessel requires 318,000 lbs of sulfur media.	Engineering Fabrication Initial Chemical Fill Licensing fees O&M Manuals Start up training costs Tax & FOB	\$332,000	For each vessel media change-out is required 3 times a year Media disposal Vacuum truck and water truck to flush out media	\$12,450,000	\$12,483,200	\$3,333.33	Flexus, Pittsburg, PA - Molten Sulfur Rail Co. Cytac, Toronto - Specialty chemical OMV, Pakistan - Natural gas (replaced Puraspec due to high media costs)	< 1 ppm	Gas technology Products David Graubard 847.285.3855	Vendor did not recommend this technology for this application.
Bioponic	Consists of: 24 scrubbers - 13' dia and 42' high, recirculation pumps, air blower, biomass, nutrients, blower and connecting piping, 2 control panels, 2 control skids 8' x 25' x 8' high. Each unit handles 400 scfm. No licensing fees associated.	Equipment package Structural supports Foundation Piping and valving Electrical and conduit trenching Startup cost Biomeia Tax & FOB	\$16,600,000	Labor costs Maintenance Electricity Water Nutrients Hot water/ Steam Media disposal Disposal of 17,000 gallons per day not included	\$2,324,000	\$3,984,000	\$1,063.83	Digester Gas at a Paper Mill wastewater application	97% warranty standard	Biothane Corporation Deborah Buckley 856.541.3500 x 513	
H2SPLUS (Iron Sponge)	Includes: vessels (12' diameter x 10' tall), internal piping and valve network, iron sponge media impregnated with biological agents, Fuji air blowers and controls, recycling sump and associated pump, media removal nets, Engineering design, technology license fee, 3 days of installation and start up oversight	Vessels, one time media fill, blowers, pumps, and internal piping	\$4,170,000	includes media change outs (man hours at \$50 / hr, 25 ton crane for 3 days at \$5000/ change out, sucker truck at \$4000/ change out, boom truck at \$3000/ change out Electricity costs not included	\$4,170,000	\$4,587,000	\$1151.36	Odor and H2S removal at: Cargill's Excel facility in Ft. Morgan, CO; Dodge city, KS, Simplot foods in Burley, ID; Coors Brewing Co, Golden, CO; asphalt plants; agricultural landfills	This technology can achieve 95% for the given costs. Higher efficiencies can be achieved by adding more treatment vessels	Miami Varani, LLC Paul Trost 303.277.1625	
Sulfatreat	Consists of: 2 vessels 120" dia x 32' high. Blower is not required. No licensing fees associated.	Includes: 2 vessels, piping, valving and 1st fill of media. Tax & FOB Bag lifting device Moisture knockout drum	NA - no quote received due to physical obstacles associated with using this technology at this site (i.e. 20,000 lbs of spent media/day for disposal and re-charge)	600,000 lbs of media replacement required every 30 days. Foam filters Media disposal Water truck and Vac truck	NA	NA	NA	Monmouth County LF, NJ and Freshkills LF, Staten Island, NY	95%	Sulfatreat Mike Civili 636.532.2189	Vendor did not supply a quote due to the massive amounts of media required for this technology under the guidelines of this application.

Table 2-4 Summary of Technologies and Parameters for BACT Analysis

Technologies	Description	Capital Cost Items	Capital Cost	Annual Cost Items	Annual O&M Cost	Annualized Cost (over 10 years)	Cost per Ton of SO ₂ Removed	Known Applications	Performance	Vendor Info	Comments or Notes
Sulfa Bind	Includes: 20 - 10' dia. x 20' long media filter units. Media is a diatomite, coated with ferric hydroxide having grain size of sand - 0.3 mm dia. No engineering fees associated. No licensing fees associated.	Includes 4 filters, piping, valving, purge points, control panel and media. Tax & FOB Piping and support from main gas line Foundation 1" fill of media Design package Condensate piping and collection system	\$9,794,000	Regeneration of media, via air purge, is required every 4days. Regeneration time is 8-12 hours, offline. 13 regenerations possible until media change out is required. Media will need to be changed 8 times a year One change out per unit is 37,000 lbs of media at a cost of \$0.70/lb.	\$7,811,960	\$8,791,360	\$2,347.34	First landfill installation pilot test to start at Brookhaven, Long Island, NY in October 2004. (Client preferred this technology over Sulfatreat.)	Has proven to reduce 30,000 ppm H ₂ S inlet concentration to below 1-2 ppm at wastewater treatment plants.	ADI Mike McMullin 1 800 858 1888	
Thiopaq	Includes: absorber, control system, sulfur settler, sulfur handling equipment, forced draft or induced draft blower, engineering design fees, licensing fees, and some required piping.	Sulfur handling equipment: CentInfluge = \$100,000	\$3,486,000	Includes: chemical costs, water, soda and nutrients. Includes electrical cost at \$ 0.08/KWH.	\$5,976,000	\$6,324,600	\$1,688.83	In US: Used at WWTP, Cedar Rapids, IA for treating digester gas at a lagoon for beef parts. Used at 38 locations outside US, including landfills.	95% for the presented cost. (However, technology can achieve up to 99.99% for a higher cost.)	NATCO David Meridadian 713 685.8095	
Enviro-Scrub	Consists of a physio-chemical process that involves sparging gas through a non-regenerable sulfur removing solution	NA	NA	NA	NA	NA	NA	NA	NA	Q2 14729 Highway 105 West Suite 200 Montgomery TX, 77356 (936) 588-2242	Vendor did not supply a quote; this technology cannot efficiently treat the sulfur at the flow rates and H ₂ S concentrations specified for this project.
Enviro-Tek	Consists of a physio-chemical process that involves sparging gas through a regenerable sulfur removing solution	NA	NA	NA	NA	NA	NA	NA	NA	Q2 14729 Highway 105 West Suite 200 Montgomery TX, 77356 (936) 588-2242	Vendor did not supply a quote; this technology cannot efficiently treat the sulfur at the flow rates and H ₂ S concentrations specified for this project.
Use On Indiantown Co-Gen	Pipe the gas to the Indiantown power plant, about 26 miles.	Permitting, design, construction, materials and equipment	\$50,000,000	Operation of the pipeline; \$100,000	\$100,000	\$1.6 Million	\$804.00		90%	NA	Revenue from sale of gas may offset some costs; fits well with Florida Energy plan

Notes (1) All costs were determined based upon actual quotes provided by the vendors listed.

(2) The provided cost quotes were based upon flow rates of 9,000 scfm and up-scaled to 15,000 scfm

Table 2-5 – Best Available Control Technology Analysis Ranking

Technologies	Cost per Ton of SO ₂ Removed	Performance	Comments or Notes	Rank
LO-CAT®	\$267.03	98%	Application at Central landfill has had notable success.	1
Use On Indiantown Co-Gen	\$804.66	90%	Revenue from sale of LFG may partially offset costs; fits well with FL Energy plan	2
Biopuric	\$1,063.83	97%	Almost 4X as costly as LO-CAT®	3
H2SPLUS	\$1151.36	95%	More than 4X as costly as LO-CAT®	4
Thiopaq	\$1,688.83	95%	More than 6X as costly as LO-CAT®	5
Sulfa Bind	\$2,347.34	<1-2 ppm	Almost 9X as costly as LO-CAT®	6
Sulfur-Rite®	\$3,333.33	< 1 ppm	More than 12X as costly as LO-CAT®	7
Biofilter Tricking	NA	NA	Innovative technology; cost and effectiveness not fully developed.	Innovative/Unproven
Enviro-Scrub	NA	NA	Vendor did not supply quote; this technology cannot efficiently treat the sulfur at the flow rate and H ₂ S conc. specified.	Unavailable
Enviro-Tek	NA	NA	Vendor did not supply quote; this technology cannot efficiently treat the sulfur at the flow rate and H ₂ S conc. specified.	Unavailable
Sulfatreat	NA	95%	Vendor did not supply quote; this technology cannot efficiently treat the sulfur at the flow rate and H ₂ S conc. specified.	Unavailable

3.0 BACT: NO₂

Oxides of nitrogen (NO, NO₂ and NO₃ – jointly referred to as NO_x) are products of thermal combustion processes. There are two components of NO_x formation:

“Fuel NO_x” is caused by the direct oxidation of fuel-bound-nitrogen; i.e., nitrogen that is chemically part of the fuel molecules.

“Thermal NO_x” is formed at high temperatures (generally in excess of 2100°F) by the dissociation of N₂ in the combustion air and recombination with oxygen. Thermal NO_x is predominantly NO, though NO converts to NO₂ in the presence of oxygen and with time. Trace amounts of NO₃ may also be formed, but the fraction is so small that it can be ignored for most practical purposes regarding NO_x control.

Fuel-bound-nitrogen is a concern only in liquid and solid fuels and some refinery fuel gases. There is essentially no fuel-bound-nitrogen in gaseous fuels such as natural gas or landfill gas. Nitrogen in these gaseous fuels is free nitrogen, N₂, which acts like the N₂ in the combustion air. Combustion air is the source of 99% of the free nitrogen involved in the combustion process. Therefore, referrals to NO_x in the remainder of this report are to thermal NO_x.

Although NO_x emissions from a combustion source are a mix of NO and NO₂, it is NO₂ that is the pollutant of concern. Stack measurements of NO_x are therefore reported as NO₂

3.1 USEPA TECHNOLOGY CLEARINGHOUSE DATABASE FOR NO₂

A review was made of the USEPA RACT BACT LAER Clearinghouse by using the USE PA web site www.epa.gov/ttn/catc/rblc. The database was searched for process information related to landfill gas with the pollutant NO_x. The results are summarized in the **Table 3-1**.

**Table 3-1
 USEPA TTN Database search parameters and results for NO_x**

Process Information	Result
Fuel Combustion	
<i>Utility and Large Industrial Boiler/ Furnaces</i>	
11.320 LF/ Digester/ Bio-gas	1 Facility
<i>Industrial Size Boilers/ furnaces (> 100 mi)</i>	
Gaseous fuel and mixtures	
12.320 LF/ Digester/ Bio-Gas	None
<i>Commercial/ Industrial size boilers/ furnaces</i>	
Gaseous fuel and mixtures	
13.320 LF/ Digester/ Bio-Gas	None
<i>Large combustion Turbines (> 25 MW)</i>	
Simple Cycle	
15.120 LF/ Digester/ Bio-Gas	None
Combined Cycle and Co-generation	
15.220 LF/ Digester/ Bio-Gas	None
<i>Small Combustion Turbines (<25 MW)</i>	
Simple Cycle	
16.120 LF/ Digester/ Bio-Gas	1 Facility
Combined Cycle and Co-generation	
16.220 LF/ Digester/ Bio-Gas	None

Process Information	Result
<i>Internal Combustion Engine</i>	
Large Internal Combustion Engine (> 500 HP) 17.140 LF/ Digester/ Bio-Gas	11 Facilities
Small Internal Combustion Engine 17.240 LF/ Digester/ Bio-Gas	1 Facility
<i>Miscellaneous Combustion</i>	
Flares 19.320 Digester & LF Gas Flares	16 Facilities and 18 Processes

There was one facility identified as a simple-cycle Combustion Turbine Generator (CTG) burning landfill gas. However, the Pennsylvania Department of Environmental Protection was contacted and it stated that these units were never built.

A review was also conducted of the California Air Resources Board BACT/LAER Clearinghouse as of February 21, 2007 for landfill gas-fired combustion turbines. There are no entries in the CARB database.

3.2 OVERVIEW OF NO_x CONTROL TECHNOLOGIES

Approaches to NO_x control for combustion turbines burning gaseous fuels are of two types:

Combustion modifications aimed generally at reducing the effective flame temperature. Since NO_x formation is temperature-sensitive, lowering the flame temperature reduces NO_x formation.

3.3 NO_x CONTROL TECHNOLOGY DESCRIPTIONS

Conventional CTG combustors utilize a diffusion flame, essentially mixing air with a gaseous fuel to obtain a flammable mixture and then burning it. The result is a very hot central region to the flame, cooling as it continues to diffuse more air into the combustion process. That hot zone is where most of the NO_x is formed. Typical NO_x emission rates from a natural gas-fired CTG with traditional diffusion burners are on the order of 150-250 ppm depending on other design parameters of the engines.

3.3.1 Combustion Modification

There are three general approaches to combustion modification to reduce the effective temperature of that flame, staged combustion, catalytic combustion and the addition of diluents.

3.3.1.1 Staged Combustion

In staged combustion, a limited amount of air is combined thoroughly with the fuel and combustion is started in a sub-stoichiometric mixture at low temperature. Subsequent stages add more air and complete the combustion process. In this manner, there is no hot central core to the flame; the combustion process occurs uniformly across the entire combustor. Staged combustion is known by various trade names associated with specific CTG manufacturers; e.g., Dry Low-NO_xTM (General Electric), Dry-Low EmissionsTM (Rolls-Royce) and SoLoNO_xTM (Solar Turbines). Although there are differences in actual combustor design, the principals are the same. Staged combustors have routinely achieved NO_x emission rates in the single digits in natural gas-fired CTGs. However, combustor

design is highly fuel-specific. Even regional variations in natural gas composition lead to variations in combustor design.

Staged combustion has not been developed for landfill gas combustion in CTGs and is not commercially available for the Solar Mars 100 CTGs proposed for this project.

3.3.1.2 Catalytic Combustion

Catalytic combustion, such as Xonon™, places a catalyst within the combustion chamber of a gas-fired CTG. This is a cool combustion technology which combusts fuel at temperatures below that at which thermal NOx is formed. This is a recent development to NOx control technology; the first commercial unit is about to, or has recently, commenced initial operation. This technology, though promising, is in the early stages of commercialization. It has not been applied to a landfill gas-fired CTG and is not available on the selected Mars 100 CTG.

3.3.1.3 Diluent Injection

Various diluents have been used for NOx control in fossil-fuel-fired CTGs. Water is the most common diluent and has been commonly used since the 1970s. Water is introduced into the combustion chamber, either by a finely atomized spray or by physical mixing with the fuel (limited to liquid fuels). The water absorbs heat from the combustion process as it evaporates, lowering the flame temperature while not significantly interfering with the combustion process.

With landfill gas-fired CTGs, however, the flame temperature is already considerably lower than in a natural gas-fired CTG because the gas is already diluted by about 50% with CO₂, a natural product of landfill gas production. A turbine manufacturer has indicated that natural variability in landfill gas quality and the already-diluted character of the fuel would make water injection a technical challenge, potentially leading to flame instability, which in turn can severely shorten the life of turbine components, create a safety hazard, and greatly increase CO emissions due to combustion interference, hence incomplete combustion.

Water injection is not currently available for landfill gas-fired Mars 100 CTGs.

Where available, as in combined cycle power plants, steam is similarly used as a diluent to absorb combustion heat. Steam is not available at the project site, nor does Solar offer steam injection as a NOx control option for its turbines.

Landfill gas is naturally diluted with CO₂, as indicated above. CO₂ operates in the flame just as water or steam would; it reduces the flame temperature that is achieved during combustion. Whereas a natural gas-fired Mars CTG with conventional combustors would have NOx emissions rates of ~200 ppm, firing landfill gas produces NOx emissions of about 60 ppm. Other CTGs may have slightly different NOx emissions depending upon the specifics of the gas quality and CTG design. In effect, having CO₂ as a natural diluent reduces NOx emissions by ~70%.

As the Solar Mars 100 is a high-efficiency engine with high compression ratio and "firing temperature" (firing temperature is not the same as flame temperature – it generally refers to the gas temperature entering the power turbine section of the CTG, not the temperature in the combustion zone), its emissions are slightly higher than some of the lower efficiency models. Solar has quoted 60 ppm NOx as a guaranteed emission rate for the Mars units for this project; actual emission rate may be somewhat lower. This is below the recent New Source Performance Standard for Stationary Combustion Turbines, 40CFR60 Subpart KKKK, which limits NOx for small simple-cycle CTGs burning other than natural gas or oil to 74 ppm NOx.

3.3.2 Post-Combustion Control

There are a number of processes available for NO_x removal in a gas stream; however, almost all are designed to operate in the chemical manufacturing and refining industries processing streams with concentrations from hundreds to tens of thousands of ppm NO_x and are not applicable to processing highly dilute gas flows. Examples include Single and Multiple Stage High Efficiency Nitrogen Oxide (NO_x) Control Scrubbing Systems, similar to those produced by Duall and low temperature oxidation technology, LoTOx™ Technology, from BELCO® under license from BOC. This latter technology has strong synergy with EDV® scrubbing for refinery applications such as FCCU, fluid cokers, heaters and boilers.

3.3.2.1 SNCR

The Wheelabrator NO_xOUT™ Process and other similar selective non-catalytic reduction (SNCR) technologies have been utilized commercially to reduce NO_x emissions in boiler applications. It is not applicable to combustion turbines as it requires injection of urea or ammonia into the combustion gases in a narrow temperature range, 1600°F - 2100°F, where it reacts with NO_x to form N₂ and water vapor. In a combustion turbine, this temperature range generally occurs within the power turbine section. No current CTG has the capability of injecting a gas in that zone.

3.3.2.2 SCONOX™

SCONOX is a catalytic NO_x reduction technology. A mesh or honeycomb substrate coated with a regenerable catalyst is placed in the CTGs exhaust gas path. NO_x is catalytically reacted resulting in formation of a nitrogen-based compound that remains in the coating. The catalyst is periodically taken out of service and regenerated, releasing the nitrogen that was formerly NO_x as nitrogen gas. Its apparent advantage over selective catalytic reduction (SCR), which is discussed later herein, is that ammonia is not required in the process.

This technology was technically demonstrated on a 20MW natural gas-fired CTG in the mid-1990s. It was later applied commercially to a Solar Mars turbine installation in MA that was fired with natural gas and occasionally distillate oil. After several years of continuous development, that unit was reportedly recently shut down having not continuously achieved its target performance, and plans for a second identical unit have been canceled.

The technology was offered for several years for larger U.S. power plant applications under license to ABB (later Ahlstrom) Environmental Systems, but was never utilized, in part because its cost was extreme.

This technology is not applicable to the proposed project. It requires gas temperatures that are much lower than those from a simple cycle combustion turbine installation. The process is also highly sensitive to sulfur in compounds in the gas stream. It has not been demonstrated burning landfill gas and is considered technically infeasible as well as commercially undemonstrated.

3.3.2.3 SCR

Selective catalytic reduction (SCR) is a catalytic NO_x removal process. Ammonia is injected into the exhaust gas flow which then passes over a catalyst coated mesh or honeycomb placed in the exhaust duct. Ammonia and NO_x react to N₂ and H₂O. Excess ammonia passes through unreacted and is emitted to the atmosphere.

There are two general categories of SCR systems, referred to herein as conventional and high-temperature systems. Conventional catalyst systems are limited to operation at <850°F. Even short-term excursions above that temperature can permanently damage the catalyst structure. The exhaust temperature of simple cycle CTGs varies with make, model, fuel and ambient conditions, but for a landfill gas-fired Solar Mars engine is 900 to 925 °F during the majority of the year (i.e., at ambient temperatures of 60°F or greater).

A few installations of conventional SCR on simple cycle CTGs have been accomplished by adding fresh air to the exhaust flow using dilution air fans, lowering the exhaust temperature to below 850°F. In those cases, the specific engines had peak exhaust temperatures in the range of 870-880°F. These are generally fossil-fuel-fired CTGs in utility peaking service, operating only a few hours per year. The energy penalty of adding dilution air makes the technique impractical for continuously operated units.

High temperature SCR uses a different type of catalyst which comprises the entire catalyst structure; i.e., is not just a coating. It can be used at operating temperatures exceeding the expected exhaust temperatures of the Project's CTGs. This technology has been only rarely applied, however, because it is considerably more expensive than conventional SCRs.

Virtually all SCR experience is on fossil fuel-fired CTGs. Landfill gas contains siloxanes, a silicone-carbon compound that oxidizes to silicone dioxide, SiO₂, when combusted. SiO₂ will then coat downstream components, fouling a catalyst placed in the gas path.

"There are numerous examples where SiO₂ deposits from siloxane have resulted in catalyst deactivation in hours or days.their rapid destructive effects makes this [use of a catalyst for emission control] a difficult application."¹

For this reason, use of SCR is not technically feasible for use with landfill gas-fired engines.

3.4 NO₂ CONTROL TECHNOLOGY ANALYSIS

The natural diluent effects of CO₂ in landfill gas greatly reduce NO_x formation that would otherwise occur from burning the methane component. Other combustion modifications, such as water injection or staged combustion, have not been applied to landfill gas-fired CTGs.

Post-combustion controls are not technically feasible for landfill gas-fired CTGs due to contaminants in the landfill gas that will coat and damage catalysts.

3.5 NO₂ BACT SELECTION

3.5.1 Combustion Turbines

The turbines selected for the project were selected because of their ability to burn landfill gas efficiently and steadily. The emissions from the turbines will be limited to 60 ppm, which is lower than the applicable requirement of NSPS subpart KKKK

¹ "Siloxanes in Landfill and Digester Gas Update", Wheless, Ed, Los Angeles County Sanitation District and Pierce, Jeffrey, SCS Energy (date unknown)

3.5.2 Flares

The application also reviewed the literature for BACT that had been applied to flares. The project will utilize flares as back up devices for the turbines. The flares will also be the initial control devices until the turbines are installed. The RBLC was queried for control systems to be applied to flares. The flares are the control devices. The RBLC lists flares as control devices for the petroleum industry, chemical industry, waste water treatment and landfill gas. They are generally employed where waste gas would be discharged untreated to the atmosphere. That will be the application of the flares in this project.

There are two techniques which are discussed for the better operation of the flares. The techniques are steam assisted flares and air assisted flares². These techniques are used to create a smokeless flare when the material being flared is difficult to combust when passively mixed with air. Flares developed for landfill gas are smokeless by design.

The flares being proposed for this project will be smokeless flares designed to burn landfill gas.

4.0 BACT: CO

Carbon monoxide is a product of incomplete combustion. A combustion turbine-generator ("CTG"), as a technology, is inherently highly efficient in combusting fuel; typical CO emissions from a fossil-fueled CTGs are <10 ppm at full load. CO emissions from non-fossil fuels such as landfill gas are slightly higher due to the lower flame temperature at which this fuel burns. Nevertheless, these emission rates are one to two orders of magnitude below conventional boilers and IC engines.

CO emissions from combustion turbines generally increase

- as load decreases
- When diluents, such as water, are used to control NOx emissions.

4.1 USEPA Technology Clearinghouse Database for CO

A review was made of the USEPA RACT BACT LAER Clearinghouse as of February 19, 2007, by using the USEPA web site www.epa.gov/ttn/catc/rblc. The data base was searched for landfills with the pollutant CO. The results are summarized in Table 4-1. No facilities were found in the database using landfill gas to operate a combustion turbine.

Table 4-1
USEPA TTN Database: Search Parameters and Results for CO

Process Information	Result
Fuel Combustion <i>Utility and Large Industrial Boiler/ Furnaces</i> 11.320 LF/ Digester/ Bio-gas <i>Industrial Size Boilers/ furnaces (> 100 mi)</i>	1 Facility

² Air and Waste Management association, Air pollution Engineering Manual, Second Edition, Davis, Wayne,ed.;2000

Process Information	Result
Gaseous fuel and mixtures 12.320 LF/ Digester/ Bio-Gas	None
<i>Commercial/ Industrial size boilers/ furnaces</i>	
Gaseous fuel and mixtures 13.320 LF/ Digester/ Bio-Gas	None
<i>Large combustion Turbines (> 25 MW)</i>	
Simple Cycle 15.120 LF/ Digester/ Bio-Gas	None
Combined Cycle and Co-generation 15.220 LF/ Digester/ Bio-Gas	
<i>Small Combustion Turbines (<25 MW)</i>	None
Simple Cycle 16.120 LF/ Digester/ Bio-Gas	
Combined Cycle and Co-generation 16.220 LF/ Digester/ Bio-Gas	None
<i>Internal Combustion Engine</i>	
Large Internal Combustion Engine (> 500 HP) 17.140 LF/ Digester/ Bio-Gas	11 Facilities
Small Internal Combustion Engine 17.240 LF/ Digester/ Bio-Gas	
<i>Miscellaneous Combustion</i>	1 Facility
Flares 19.320 Digester & LF Gas Flares	
	14 Facilities and 16 Processes (??)

A review was also conducted of the California Air Resources Board BACT/LAER Clearinghouse as of February 21, 2007 for landfill gas-fired combustion turbines. There are no entries in the CARB database.

4.2 Overview of CO Control Technologies

CO emissions are controlled by either combustor design or by add-on flue gas treatment.

Generation of CO is a function of the efficiency of the combustion process. Combustion turbines, as a technology, are inherently highly efficient in combusting fuel, resulting in very low CO emissions compared, for example, to conventional boilers and IC engines.

Add-on systems for CO control are comprised of oxidation catalysts placed in the hot exhaust gas flow.

4.3 CO Control Technology Descriptions

4.3.1 Combustion Control

Generally, the control of NOx through combustion modification and the generation of CO are interdependent. When NOx is reduced by changes in the combustion process (staged combustion or dry low-NOx technology, use of diluent such as water, etc), CO increases. However, since such NOx controls are not being proposed for this project (see NOx BACT sections), this is not relevant to this CO BACT analysis.

Because burner and combustion chamber design are the principal features ensuring high combustion efficiency in a combustion turbine-generator ("CTG"), fuels of variable quality,

such as digester or landfill gas and refinery fuel gas, can affect CO emission rates. Thus manufacturers' data include higher CO emission rates than for natural gas or oil-fired CTGs. Furthermore, there are relatively few CTGs burning landfill gas, and none of the Mars 100 units selected for this project; therefore, there is less confidence in the available data, further increasing the emission rates that manufacturers will guarantee.

In addition, CO emission rates can be sensitive to very slight differences in manufacturing and operation; hence CO emission rates may vary from installation to installation of the same make and model combustion turbine. As a result, combustion turbine manufacturers include significant margin in their CO emissions guarantees.

Solar Turbines, the manufacturer of the proposed CTGs, has provided an guarantee for CO emission rate of 60 parts per million, by volume, dry, corrected to 15% O₂ ("ppmv"),

4.3.2 Post Combustion Catalytic Controls

Oxidation catalysts have been commonly used on natural gas-fired combustion turbines. However, this technology is not applicable to units burning landfill gas. Landfill gas contains contaminants, specifically siloxanes that convert to SiO₂ in the combustion process. The SiO₂ will quickly foul downstream components, including catalysts. This is summarized in a U.S. EPA memorandum.³

"Oxidation Catalyst systems can be used on combustion turbines which combust all types of gaseous and liquid fuels except for landfill and digester gases, which foul the catalyst very quickly because of a compound called siloxanes contained in these fuels. Siloxanes are difficult and very costly to remove from these fuels. Therefore, the application of oxidation catalyst systems to combustion turbines that burn landfill or digester gas does not appear to be feasible. Also there are no known installations of oxidation catalysts on combustion turbines burning landfill or digester gas."

4.3.3 Combustion Design

Generally, the control of NO_x through combustion modification and the generation of CO are interdependent. When NO_x is reduced by changes in the combustion process (staged combustion or dry low-NO_x technology, use of diluent such as water, etc), CO increases. However, since such NO_x controls are not being proposed for this project (see NO_x BACT sections), this is not relevant to this CO BACT analysis.

Because burner and combustion chamber design are the principal features ensuring high combustion efficiency in a combustion turbine-generator ("CTG"), fuels of variable quality, such as digester or landfill gas and refinery fuel gas, can affect CO emission rates. Thus manufacturers' data include higher CO emission rates than for natural gas or oil-fired CTGs. Furthermore, there are relatively few CTGs burning landfill gas, and none of the Mars 100 units selected for this project; therefore, there is less confidence in the available data, further increasing the emission rates that manufacturers will guarantee.

In addition, CO emission rates can be sensitive to very slight differences in manufacturing and operation; hence CO emission rates may vary from installation to installation of the same make and model combustion turbine. As a result, combustion turbine manufacturers include significant margin in their CO emissions guarantees.

³"Hazardous Air Pollutant (HAP) Emission Control Technology for New Stationary Combustion Turbines", U.S. EPA memorandum from Sims Roy, Emission Standards Division, Combustion Group, to Docket A-95-51, August 21, 2001.

Solar Turbines, the manufacturer of the proposed CTGs, has provided a guarantee for a CO emission rate of 60 parts per million, by volume, dry, corrected to 15% O₂ ("ppmv").

4.3.4 Post combustion catalytic controls

Oxidation catalysts have been commonly used on natural gas-fired combustion turbines. However, this technology is not applicable to units burning landfill gas. Landfill gas contains contaminants, specifically siloxanes that convert to SiO₂ in the combustion process. The SiO₂ will quickly foul downstream components, including catalysts. This is summarized in a U.S. EPA memorandum.

"Oxidation Catalyst systems can be used on combustion turbines which combust all types of gaseous and liquid fuels except for landfill and digester gases, which foul the catalyst very quickly because of a compound called siloxanes contained in these fuels. Siloxanes are difficult and very costly to remove from these fuels. Therefore, the application of oxidation catalyst systems to combustion turbines that burn landfill or digester gas does not appear to be feasible. Also there are no known installations of oxidation catalysts on combustion turbines burning landfill or digester gas."⁴

4.4 CO Control Technology Analysis

Certain factors, such as limited use burning landfill gas and the lower flame temperature associated with landfill gas firing (compared to oil or natural gas firing) result in higher CO emissions guarantees from manufacturers than for fossil-fueled combustion turbines. Nevertheless, combustion turbines have inherently efficient combustion systems resulting in low CO emissions.

There are no post-combustion controls for additional CO control that are technically feasible.

4.5 CO BACT Selection

The Applicant has chosen the use of combustion turbines that employ highly efficient combustion control to minimize CO emissions to 60 ppmv or less at full load.

5.0 BACT: PM₁₀

The primary method of controlling PM₁₀ emissions from a CTG is use of clean-burning fuels. PM₁₀ emissions from gas-fired CTGs are extremely low and are generally comprised of trace contaminants in the fuel and uncombusted VOCs that form condensable particulate matter in the turbine exhaust. Trace amounts of filterable PM₁₀ may also occur from combustion products. PM₁₀ concentrations in the exhaust of gas-fired CTGs are so small that it takes special test procedures (exceptionally large sample volumes) to measure them.

5.1 USEPA TECHNOLOGY CLEARINGHOUSE DATABASE FOR PM₁₀

A review was made of the USEPA RACT/BACT/LAER Clearinghouse as of February 19, 2007, by using the USEPA web site www.epa.gov/ttn/catc/rblc. The data base was searched for landfills with the pollutant PM₁₀. The results are summarized in **Table 5-1**. No facilities were found in the database using landfill gas to operate a combustion turbine.

⁴ "Hazardous Air Pollutant (HAP) Emission Control Technology for New Stationary Combustion Turbines", U.S. EPA memorandum from Sims Roy, Emission Standards Division, Combustion Group, to Docket A-95-51, August 21, 2001.

**Table 5-1
 USEPA TTN Database search parameters and results for PM**

Process Information	Result
Fuel Combustion	
<i>Utility and Large Industrial Boiler/ Furnaces</i> 11.320 LF/ Digester/ Bio-gas	None
<i>Industrial Size Boilers/ furnaces (> 100 mi)</i> Gaseous fuel and mixtures 12.320 LF/ Digester/ Bio-Gas	None
<i>Commercial/ Industrial size boilers/ furnaces</i> Gaseous fuel and mixtures 13.320 LF/ Digester/ Bio-Gas	None
<i>Large combustion Turbines (> 25 MW)</i> Simple Cycle 15.120 LF/ Digester/ Bio-Gas	None
Combined Cycle and Co-generation 15.220 LF/ Digester/ Bio-Gas	None
<i>Small Combustion Turbines (<25 MW)</i> Simple Cycle 16.120 LF/ Digester/ Bio-Gas	None
Combined Cycle and Co-generation 16.220 LF/ Digester/ Bio-Gas	None
<i>Internal Combustion Engine</i> Large Internal Combustion Engine (> 500 HP) 17.140 LF/ Digester/ Bio-Gas	9 Facilities
Small Internal Combustion Engine 17.240 LF/ Digester/ Bio-Gas	1 Facility
<i>Miscellaneous Combustion</i> Flares 19.320 Digester & LF Gas Flares	5 Facilities and 7 Processes

5.2 OVERVIEW OF PM₁₀ CONTROL TECHNOLOGIES

PM₁₀ emissions are controlled by minimizing particulate matter in the fuel, filtering the combustion air entering the engine, and insuring high efficiency combustion. There are no add-on technologies that have been applied to CTG exhaust.

5.3 PM₁₀ CONTROL TECHNOLOGY DESCRIPTIONS

5.3.1 Combustion Control

The use of clean-burning gas fuels effectively minimizes PM₁₀ production. Landfill gas contains some contaminants that may contribute to PM₁₀ emissions, such as siloxane, but further control of fuel quality is impractical, particularly considering the very low PM₁₀ emission rate.

All combustion turbines utilize high efficiency inlet air filters to remove ambient particulate matter. Although this measure is taken primarily to protect the surfaces of their blades and rotors and to keep the compressor clean to maximize its efficiency, it also removes particles that would have otherwise contributed to PM₁₀ emissions.

The efficient combustion control in a modern CTG maximizes the complete combustion of the fuel gas components, keeping condensable C₃+ organic compounds to levels typically on the order of 1 ppm.

USEPA's AP-42 provides a PM₁₀ emission factor for landfill gas-fired CTGs of 0.023 lb/MMBtu. This is believed to be a representative value.

5.3.2 Post-Combustion Controls

The use of clean-burning gas fuels effectively minimizes PM₁₀ production. Landfill gas contains some contaminants that may contribute to PM₁₀ emissions, such as siloxane, but further control of fuel quality is impractical, particularly considering the very low PM₁₀ emission rate.

All combustion turbines utilize high efficiency inlet air filters to remove ambient particulate matter. Although this measure is taken primarily to protect the surfaces of their blades and rotors and to keep the compressor clean to maximize its efficiency, it also removes particles that would have otherwise contributed to PM₁₀ emissions.

The efficient combustion control in a modern CTG maximizes the complete combustion of the fuel gas components, keeping condensable C₃+ organic compounds to levels typically on the order of 1 ppm.

USEPA's AP-42 provides a PM₁₀ emission factor for landfill gas-fired CTGs of 0.023 lb/MMBtu. This is believed to be a representative value.

5.4 PM₁₀ CONTROL TECHNOLOGY ANALYSIS

Efficient combustion control combined with use of clean-burning fuel is the only method of PM₁₀ control applicable to landfill gas-fired combustion turbines. AP-42 provides an emission factor of 0.023 lb/MMBtu for a landfill gas-fired CTG.

There are no post-combustion controls that are technically feasible for additional PM₁₀ control.

5.5 PM₁₀ BACT SELECTION

The Applicant has chosen the use CTGs that employ highly efficient combustion control to minimize PM₁₀ emissions burning landfill gas to 0.023 lb/MMBtu.

Appendix G
Permit Application 1270-2
Facility ID No. 0930104
. Stack Sampling

{Permitting note: EU-003 emission is unchanged by the equipment upgrade; provided for information only.}

Appendix G
STACK SAMPLING FACILITIES (version dated 10/07/96)

Okeechobee Landfill, Inc.
Okeechobee Landfill

Permit No.: 1270-2
Facility ID No.: 0930104

Stack Sampling Facilities Provided by the Owner of an Emissions Unit. This section describes the minimum requirements for stack sampling facilities that are necessary to sample point emissions units. Sampling facilities include sampling ports, work platforms, access to work platforms, electrical power, and sampling equipment support. Emissions units must provide these facilities at their expense. All stack sampling facilities must meet any Occupational Safety and Health Administration (OSHA) Safety and Health Standards described in 29 CFR Part 1910, Subparts D and E.

(a) Permanent Test Facilities. The owner or operator of an emissions unit for which a compliance test, other than a visible emissions test, is required on at least an annual basis, shall install and maintain permanent stack sampling facilities.

(b) Temporary Test Facilities. The owner or operator of an emissions unit that is not required to conduct a compliance test on at least an annual basis may use permanent or temporary stack sampling facilities. If the owner chooses to use temporary sampling facilities on an emissions unit, and the Department elects to test the unit, such temporary facilities shall be installed on the emissions unit within 5 days of a request by the Department and remain on the emissions unit until the test is completed.

(c) Sampling Ports.

1. All sampling ports shall have a minimum inside diameter of 3 inches.

2. The ports shall be capable of being sealed when not in use.

3. The sampling ports shall be located in the stack at least 2 stack diameters or equivalent diameters downstream and at least 0.5 stack diameter or equivalent diameter upstream from any fan, bend, constriction or other flow disturbance.

4. For emissions units for which a complete application to construct has been filed prior to December 1, 1980, at least two sampling ports, 90 degrees apart, shall be installed at each sampling location on all circular stacks that have an outside diameter of 15 feet or less. For stacks with a larger diameter, four sampling ports, each 90 degrees apart, shall be installed. For emissions units for which a complete application to construct is filed on or after December 1, 1980, at least two sampling ports, 90 degrees apart, shall be installed at each sampling location on all circular stacks that have an outside diameter of 10 feet or less. For stacks with larger diameters, four sampling ports, each 90 degrees apart, shall be installed. On horizontal circular ducts, the ports shall be located so that the probe can enter the stack vertically, horizontally or at a 45 degree angle.

5. On rectangular ducts, the cross sectional area shall be divided into the number of equal areas in accordance with EPA Method 1. Sampling ports shall be provided which allow access to each sampling point. The ports shall be located so that the probe can be inserted perpendicular to the gas flow.

(d) Work Platforms.

1. Minimum size of the working platform shall be 24 square feet in area. Platforms shall be at least 3 feet wide.

2. On circular stacks with 2 sampling ports, the platform shall extend at least 110 degrees around the stack.

3. On circular stacks with more than two sampling ports, the work platform shall extend 360 degrees around the stack.

4. All platforms shall be equipped with an adequate safety rail (ropes are not acceptable), toeboard, and hinged floor-opening cover if ladder access is used to reach the platform. The safety rail directly in line with the sampling ports shall be removable

Appendix G
STACK SAMPLING FACILITIES (version dated 10/07/96)

Okeechobee Landfill, Inc.
Okeechobee Landfill

Permit No.: 1270-2
Facility ID No.: 0930104

so that no obstruction exists in an area 14 inches below each sample port and 6 inches on either side of the sampling port.

(e) Access to Work Platform.

1. Ladders to the work platform exceeding 15 feet in length shall have safety cages or fall arresters with a minimum of 3 compatible safety belts available for use by sampling personnel.

2. Walkways over free-fall areas shall be equipped with safety rails and toeboards.

(f) Electrical Power.

1. A minimum of two 120-volt AC, 20-amp outlets shall be provided at the sampling platform within 20 feet of each sampling port.

2. If extension cords are used to provide the electrical power, they shall be kept on the plant's property and be available immediately upon request by sampling personnel.

(g) Sampling Equipment Support.

1. A three-quarter inch eyebolt and an angle bracket shall be attached directly above each port on vertical stacks and above each row of sampling ports on the sides of horizontal ducts.

a. The bracket shall be a standard 3 inch x 3 inch x one-quarter inch equal-legs bracket which is 1 and one-half inches wide. A hole that is one-half inch in diameter shall be drilled through the exact center of the horizontal portion of the bracket. The horizontal portion of the bracket shall be located 14 inches above the centerline of the sampling port.

b. A three-eighth inch bolt which protrudes 2 inches from the stack may be substituted for the required bracket. The bolt shall be located 15 and one-half inches above the centerline of the sampling port.

c. The three-quarter inch eyebolt shall be capable of supporting a 500 pound working load. For stacks that are less than 12 feet in diameter, the eyebolt shall be located 48 inches above the horizontal portion of the angle bracket. For stacks that are greater than or equal to 12 feet in diameter, the eyebolt shall be located 60 inches above the horizontal portion of the angle bracket. If the eyebolt is more than 120 inches above the platform, a length of chain shall be attached to it to bring the free end of the chain to within safe reach from the platform.

2. A complete monorail or dualrail arrangement may be substituted for the eyebolt and bracket.

3. When the sample ports are located in the top of a horizontal duct, a frame shall be provided above the port to allow the sample probe to be secured during the test.

[Rule 62-297.310(6), F.A.C.]

Appendix G
EU Point (Stack/Vent) Information

Identification of Point on Plot Plan or Flow Diagram	Control Devices
Emission Point Type Code:	3 – A configuration of multiple emission points serving a single EU

Control Devices 1 and 2: Existing Enclosed Flares

Discharge Type Code:	V – A stack with an unobstructed opening discharging in a vertical or nearly vertical direction	
Stack Height	45	Feet
Exit Diameter	10	Feet
Exit Temperature	1400	Fahrenheit
Actual Volumetric Flow	179,467	acfm
Water Vapor	8	%
Max. Dry Standard Flow Rate	2,760	dscfm
Emission Point UTM Coordinates (Zone 17) Proposed Location:		
Control Device	X (m)	Y (m)
CD001	530433.068	3023829.915
CD002	530433.068	3023836.011
Comment: Flares are to be relocated when BACT installed.		

Control Devices 003 and 004:
Existing Backup and Odor Control Utility Flares

Discharge Type Code:	V – A stack with an unobstructed opening discharging in a vertical or nearly vertical direction	
Stack Height	35	Feet
Exit Diameter	1.17	Feet
Exit Temperature¹	1400	Fahrenheit
Actual Volumetric Flow	3,554	acfm
Water Vapor	8	%
Max. Dry Standard Flow Rate	3,036	dscfm
Emission Point UTM Coordinates (Zone 17) Proposed Location:		
Control Device	X (m)	Y (m)
CD003	530433.068	3023842.107
CD004	530433.068	3023848.203
Comment: Flares are to be relocated when BACT installed.		

Appendix G EU Point (Stack/Vent) Information

Control Device 005 through 010: Existing Utility Flare

Discharge Type Code:	V – A stack with an unobstructed opening discharging in a vertical or nearly vertical direction	
Stack Height	Minimum 35	Feet
Exit Diameter	Maximum 1.17	Feet
Exit Temperature¹	1400	Fahrenheit
Actual Volumetric Flow	3,554	acfm
Water Vapor	8	%
Max. Dry Standard Flow Rate	3,036	dscfm
Emission Point UTM Coordinates (Zone 17) Proposed Location:		
Control Device	X (m)	Y (m)
CD005	530433.068	3023854.299
CD006	530433.068	3023860.395
CD007	530433.068	3023866.491
CD008	530433.068	3023872.587
CD009	530433.068	3023878.683
CD010	530433.068	3023884.779
Comment: These proposed control devices would be installed as gas production increases.		

Control Device 011 through 017: LFG Turbine²

Discharge Type Code:	V – A stack with an unobstructed opening discharging in a vertical or nearly vertical direction	
Stack Height	Minimum 50	Feet
Exit Diameter	Maximum 8.37	Feet
Exit Temperature¹	894 (100% load)	Fahrenheit
Actual Volumetric Flow	193,751 (100% load)	acfm
Water Vapor	8	%
Max. Dry Standard Flow Rate	3,680	dscfm
Emission Point UTM Coordinates (Zone 17) Proposed Location:		
Control Device	X (m)	Y (m)
CD011	530470.478	3023713.238
CD012	530470.478	3023719.334
CD013	530470.478	3023725.430
CD014	530470.478	3023731.526
CD015	530470.478	3023737.622
CD016	530470.478	3023743.718
CD017	530470.478	3023749.814
Comment: These proposed control devices would be installed as gas production increases.		

¹ The Exit Temperature is based on manufacturer's information. The actual operating temperature cannot be measured for an open flare. The thermocouple provided by the manufacturer is to assure flame presence only.

² Turbine data based on Mars 100 Turbine manufactured by Solar Turbines. Another turbine may be implemented if the emissions parameters are equal or less than the Mars 100.

LO-CAT® Desulphurization System

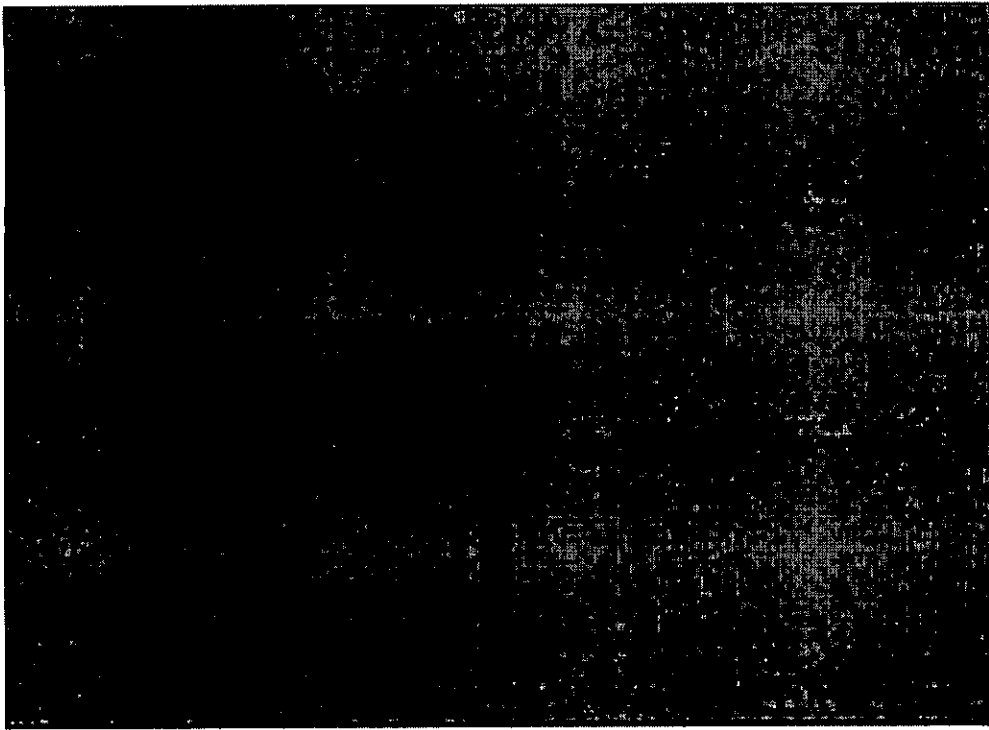

KNOCK OUT HYDROGEN SULFIDE WITH
LO-CAT[®]



COMPLETE PACKAGED SYSTEMS
FOR COST-EFFECTIVE HYDROGEN
SULFIDE REMOVAL

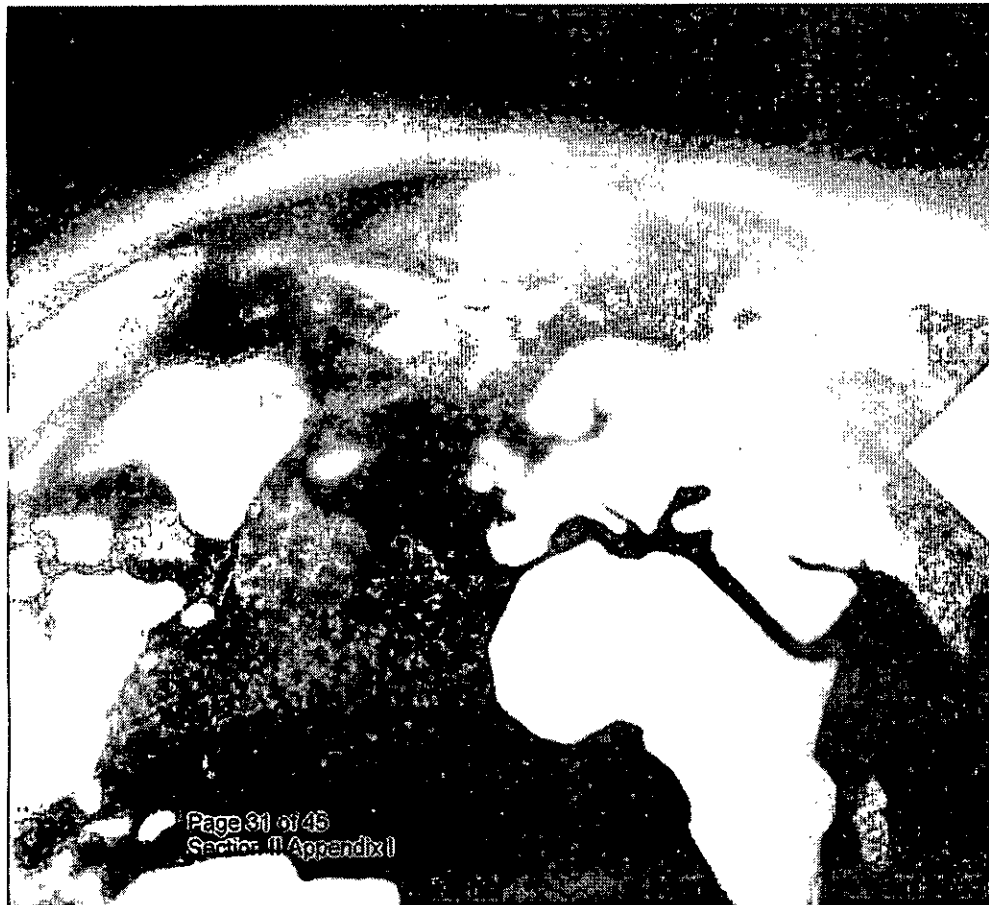

Gas Technology Products

Merichem Chemicals &
Refinery Services LLC
Application No. 1270-2

LO-CAT[®]

A COST-EFFECTIVE, ENVIRONMENTALLY FRIENDLY
WAY TO REMOVE H₂S FROM ANY GAS STREAM

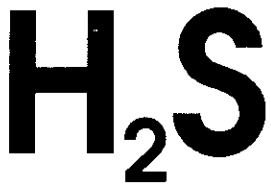
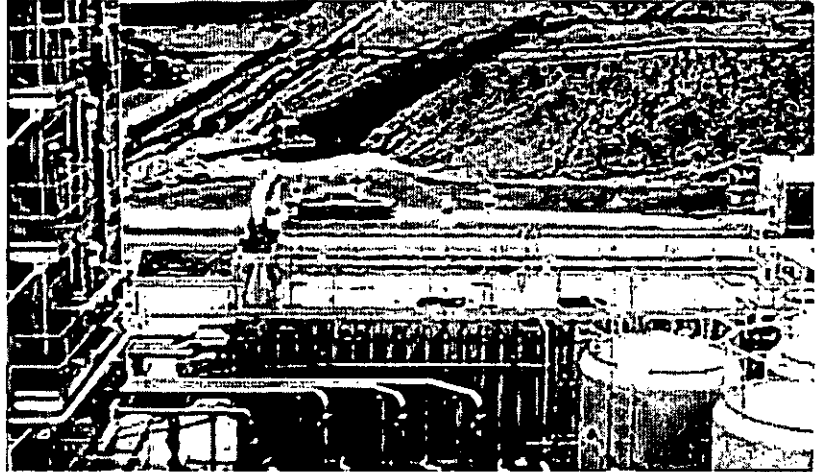

While we enjoy the fresh scent of pine forests and spring flowers, not all nature's smells are pleasant. The odor of hydrogen sulfide gas is downright offensive. But hydrogen sulfide is more than just a bad smell. It can be bad for the environment. It can be bad for the bottom line. It can be deadly.

Hydrogen sulfide is primarily a nuisance odor for wastewater treatment plants and facilities with reverse osmosis systems. But it's a nuisance that can't be ignored as residential areas encroach on once-remote plants and environmental regulations mandate odor control.

For other industries, it's more than just a bad smell. Hydrogen sulfide can be a natural component of any source of energy – natural gas, oil, geothermal steam, biogas, synthesis gas, etc. When burned, hydrogen sulfide (H₂S) forms sulfur dioxide (SO₂) – a precursor to acid rain – bringing with it the legacy of dying trees, crumbling structures, acidic surface waters... and not just in our own backyard. SO₂ is itself the subject of regulatory concern.

Even beyond the environmental problems, hydrogen sulfide is a headache for industry. H₂S becomes highly corrosive when, combined with water, it forms sulfuric acid and literally eats away at metal.

Hydrogen sulfide is a deadly poison – immediate loss of consciousness and death in as little as 30 minutes results from exposure to 500 parts per million of H₂S in air.

It's more than just a bad smell.

Gas Technology Products' **LO-CAT[®]** process is a cost-effective, environmentally friendly way to remove hydrogen sulfide from any gas stream.

LO-CAT®

LICENSEES OF THE LO-CAT® HYDROGEN SULFIDE OXIDATION PROCESS

OIL & GAS PRODUCTIONS

AGIP, SpA, Italy (AAG)* (2 units)
Alberta Nat'l Gas (AAG), Canada
Amoco Prod. Co. (EOR)* (3 units)
Amoco Oil & Gas Well Prod.
Arco Oil & Gas (EOR) Plains, TX
Atco Gas Services Ltd., Canada
(AAG)
Chemco, Mech. (NG)
Chevron Pet. Tech (AAG)
Chevron U.S.A. (EOR)
Corporven, S.A. (AAG)
Exxon Company (AAG) (2 units)
Exxon U.S.A. Inc. (AAG)
Hewitt Oil Co. (NG)
Hungarian Nat'l Oil (NG)
INA Naftaplin, Croatia (AAG)
Kuwait Petroleum
(ship unloading-loading vapors)
Lagoven, S.A. (NG)
Marathon Oil (NG)
Mobil Oil Canada (EOR)
Ellwood (Stretford conversion)
Mobil Oil Baskerfield (WHGC)*
Oil & Natural Gas Commission of
India (AAG) (3 units)
Petroelum Authority of Thailand
- PPT (NG)
Pinnacle Gas Treating (2 units) (AAG)
Rigel Oil & Gas, Canada (AAG)
Samson Resources Co.(AAG)
(2 units)
Shell Oil Co.
Tejas Gas Corp. (AAG)
Tri-link Resources Canada (AAG)
Undisclosed, Tunisia (AAG)
Union Pacific Resources Co.
(Steam flood oil prod.)
Western Gas (2 units) (AAG)

BIOGAS APPLICATIONS

FROM ANAEROBIC DIGESTERS

Boston Harbor
City of Los Angeles/Hyperion
Ellesmere Port, England
Port Adelaide, Australia
Red Star Yeast
South West Water, Hayle, England
Thames Water, Hogsmill, England
Thames Water-Wargraave, England
Wessex Water, Berryhill, England

COKE OVEN GAS DESULFURIZATION

Geneva Steel, Utah
Inland Steel (Pilot Plant)

CO₂ PURIFICATION

Consorgas S.r.L. (2 units), Italy
Praxair
Argentina
China
Mexico
Thailand (3 units)
U.S. (2 units)
Mitsui Toatsu Chemicals, Japan

GEOTHERMAL STEAM PROD.

California Energy Navy I & II
California Energy Navy II Expansion
Himpurna California Energy Inc.,
Indonesia
CE Cebu Geothermal Power,
Philippines
Visayas Geothermal Power Co.,
Philippines
UMPA, Utah Municipal Power

OIL REFINERY

Cochin Refinery, India (AAG)
Daelim Ind. Co. Ltd., Korea (AAG)
HPCL, India (AAG) (2 units)
Irish Refining, Ireland (FG)*
Koch Refining
Mobil Altona Refinery, Australia
Pennzoil Products (FG)
Petromin Lubricating Oil Refinery
Co. (AAG), Saudi Arabia
Star Enterprises (Texaco) (Asphalt)
U.S. Oil & Refining (FG)
Witco Oil (FG)
Wyoming Refining (FG)

MUNICIPAL WWTP ODOR CONTROL

City of Cappelle, Holland
City & Country of Honolulu, HI
(3 units)
Honouliuli WWTP
Kailua WWTP
Sand Island WWTP
City of Riyadh, Saudi Arabia
City of Winnipeg, Canada (2 units)
Fort Kam, Hawaii
Yorkshire Water, Rawcliffe, England

VENTILATION AIR APPLICATIONS

Martin County, Florida (RO)*
Red Star Yeast
Santa Barbara Water District
Business Park
Shanks & McEwan, Stewartby,
England
Town of Jupiter, Florida (RO)*
Westvaco Polychemicals
Zincor, So. Africa

OTHERS

BHP, Australia (hot briquetted iron)
ESD-Elektrochmelzwerk Delfzijl
B.V., Netherlands
(silicon carbide smelting)
Kronos International, Inc.,
Germany (TiO₂ production)
Louisiana Pigment, LA
(TiO₂ production)
Lubrizol, France (lube oil additives)
(2 units)
Orinoco Iron, Venezuela
(hot briquetted iron)
Praxair, Canada
(H₂S bottling)
Schumann/Sasol, Germany
(wax hydrogenation)
Texasgulf (phosphoric acid)
Viskase, Illinois
(Viscose production)
WMX, Florida (landfill gas)

REFERENCES

*AAG - Amine Acid Gas
*EOR - Enhanced Oil Recovery
*FG - Fuel Gas
*RO - Reverse Osmosis
*NG - Natural Gas
*WHGC - Well Head Gas Casing

LO-CAT[®] APPLICATIONS

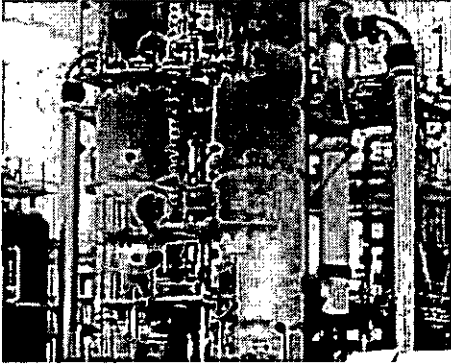

Anaerobic

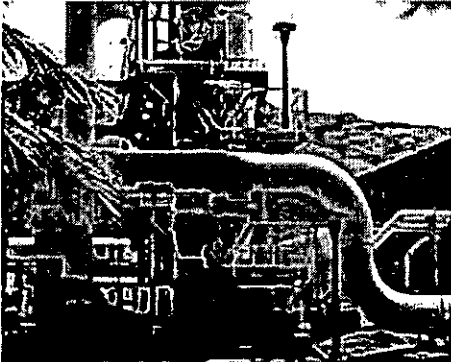

Aerobic

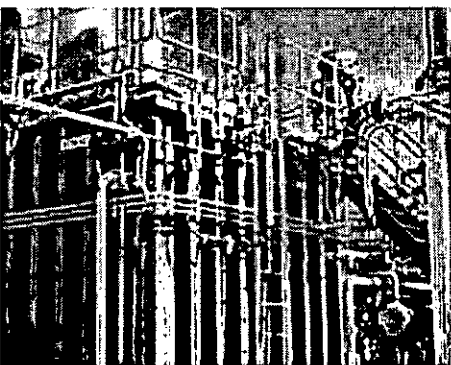

Autocirculation

LO-CAT[®] systems have proved themselves in several industries, including oil and gas production, biogas from anaerobic digesters, coke oven gas desulfurization, CO₂ purification, geothermal steam production, oil refining, odor control for municipal wastewater treatment, landfill gas, ventilation air treatment, and others.

Anaerobic Processes include LO-CAT[®] units for natural gas, refinery fuel gas, sour water stripper gas, synthetic gas from coal gasification, steel mill/coke oven gas, sewage plant digester gas, claus tail gas, CO₂ production, and EOR.

Aerobic Processes include LO-CAT[®] units for manufacturing process vents, sewage plants, wastewater treatment, and process effluent.

Autocirculation Processes include LO-CAT[®] units for amine acid gas, chemical plants, and geothermal non-condensable gases.

As you can see on the chart below – liquid reduction oxidation fits between amine/claus and H₂S scavengers or chemical oxidants.

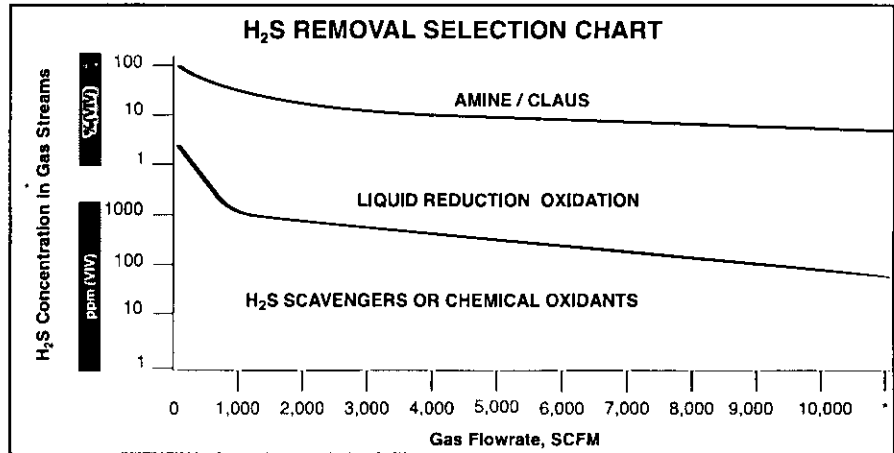

* Our general range is between 150 lbs of sulfur per day up to 20 long tons per day.

Gas Technology Products have solid, liquid and regenerable catalyst systems to custom tailor sulfur removal solutions up to 30+ tons per day.

THE LO-CAT® SOLUTION

Prompted by strict air pollution regulations and a greater concern over hazardous wastes, today's improving technology makes hydrogen sulfide removal more economical than ever.

The LO-CAT process is a patented, wet scrubbing, liquid redox system that uses a chelated iron solution to convert H₂S to innocuous, elemental sulfur. It does not use any toxic chemicals and does not produce any hazardous waste byproducts. The environmentally safe catalyst is readily available and since it's continuously regenerated in the process, less catalyst is used, more money is saved. This state-of-the-art technology is listed by the Environmental Protection Agency as maximum achievable control technology (MACT).

The LO-CAT technology is applicable to all types of gas streams including air, natural gas, CO₂, amine acid gas, biogas, landfill gas, refinery fuel gas, etc. The liquid catalyst adapts easily to variations in flow and concentration. Flexible operation allows 100% turndown in gas flow and H₂S concentrations. Units require minimal operator attention.

LO-CAT units can be designed for better than 99.9% H₂S removal efficiency.

LO-CAT. Reliable. Efficient. Economical.

LO-CAT® TOTAL PACKAGE

From engineering and design, to training and startup, through process warranties and service, we provide a Total Package. We will build to your specifications and meet your tight schedules. We provide optional turnkey projects and installation supervision.

We guarantee H₂S removal efficiency, removal capacity and chemical consumption rate. We also guarantee the continued availability of system catalyst.

We provide on-going technical service, analytical service, trouble-shooting assistance, operator training and refresher courses, annual user's seminar, technical information exchange and patent grant back program.

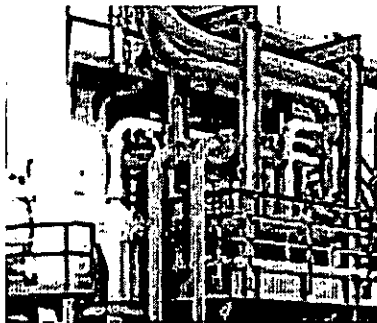
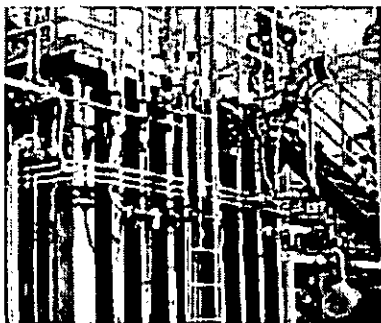

* LO-CAT and LO-CAT II are registered trademarks of Gas Technology Products.

The differences between the LO-CAT process and the LO-CAT II Process are in design. For certain applications the advanced mechanical design of LO-CAT II is appropriate.

H₂S

LO-CAT[®]

HOW THE SYSTEM WORKS

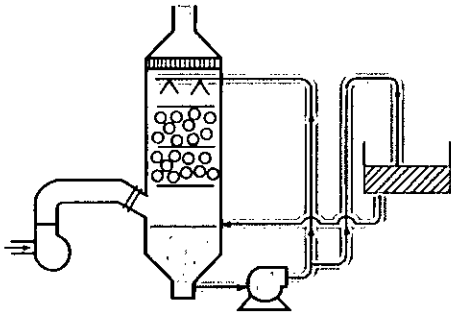

AEROBIC

The aerobic design is used where odor control is the primary concern. Typically, the air stream is discharged to atmosphere once the H₂S is removed.

Hydrogen sulfide laden air enters the absorber vessel where it comes in contact with the LO-CAT catalyst solution. The almost-instantaneous chemical reaction produces solid sulfur, which is filtered out of the catalyst solution. Oxygen present in the air stream continually regenerates the catalyst, which is used over and over again.

Air stream flowrate and H₂S concentration determine the size of the absorber. Units can be designed to handle air flow rates from a few hundred to several hundred thousand scfm and H₂S concentrations from 50 ppmv to several thousand.

ANAEROBIC

Designed to remove H₂S from anaerobic gas streams or when product recovery is desired, this LO-CAT design feature separates the absorber and oxidizer vessels. H₂S removal and conversion to solid sulfur takes place in the absorber. Reduced catalyst solution is circulated to the oxidizer and regenerated by contact with air.

Various types of sulfur handling equipment are used to remove the solid sulfur from the LO-CAT system, depending on the amount of sulfur produced. For units producing less than 1,000 lbs of sulfur per day, a bag filter system is used, which produces a 30 wt% sulfur cake. For larger units, a settler/belt filter system is used, which produces a 60 wt% sulfur cake. If desired, the belt filter cake can be melted, producing molten sulfur.

AUTOCIRCULATION

This patented system offers cost-effective treatment of anaerobic, non-explosive gas streams. Once the H₂S is removed, the sweet gas stream along with the oxidizing air is discharged to the atmosphere rather than recovered. Since the chemical reactions all occur in a single vessel, the Autocirculation process needs no catalyst circulation pumps and uses very low concentrations of catalyst.

This technology is very effective for treating effluent from amine acid gas extraction processes in natural gas production plants and the non-condensable gases released from geothermal power production.

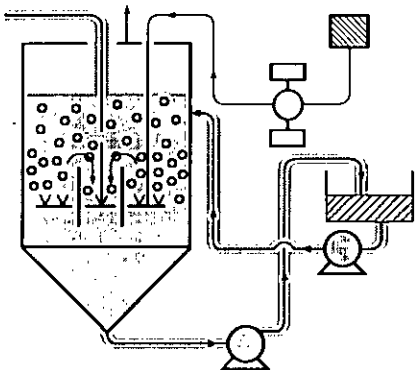
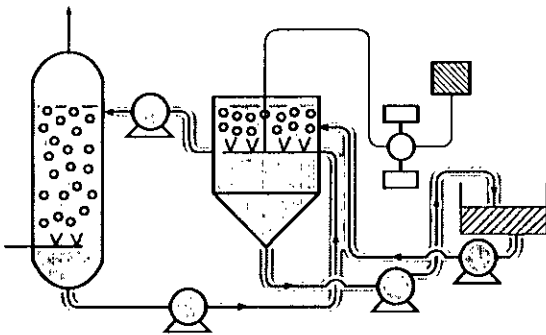

LO-CAT[®]

STATE-OF-THE-ART IN REDOX CHEMISTRY TECHNOLOGY

The basic chemistry is the same for all three system configurations. H₂S is converted to innocuous, elemental sulfur using an environmentally safe, chelated iron catalyst. The iron catalyst is held in solution by organic chelating agents that wrap around the iron ion in a claw-like fashion, preventing precipitation of either iron sulfide (FeS) or iron hydroxide (Fe(OH)₃). The LO-CAT process is based on reduction-oxidation (Redox) chemistry. Two different Redox reactions take place - one in the absorber section, which converts the H₂S to elemental sulfur, and one in the oxidizer section, which regenerates the catalyst.

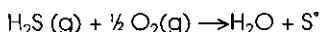
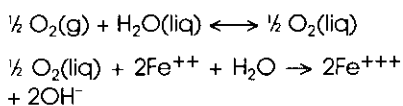
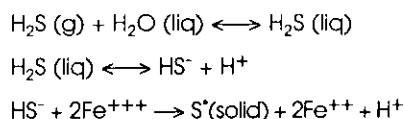

Thiosulfate Formation

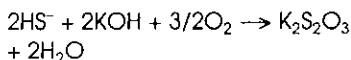

Biocarbonate Formation

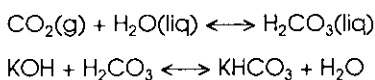

ABSORBER REACTIONS

In the absorber, H₂S is absorbed into the slightly alkaline, aqueous LO-CAT solution. The H₂S ionizes to bisulfide, which is oxidized to sulfur by reducing the iron ion from the ferric to the ferrous state. The reduced iron ions are then transferred from the absorber to the oxidizer.

OXIDIZER REACTIONS

In the oxidizer, atmospheric oxygen is absorbed into the LO-CAT solution. The ferrous iron is reoxidized to ferric iron, regenerating the catalyst. The regenerated catalyst is ready for use in the absorber section.

OVERALL REACTIONS

The overall reaction is an isothermal, low operating cost method of carrying out a modified Claus reaction. The chemical additions required to maintain the above reactions are caustic for maintaining the pH, replacement of chelated iron lost in the sulfur removal process, and replacement of degraded chelating agents.

SIDE REACTIONS

As with any chemical process, side reactions can occur during the LO-CAT process. For example, thiosulfate formation increases greatly when oxygen is present in the sour gas. This occurs when the sour gas being treated is an air stream or when the sour gas has been contaminated with air. Thiosulfate does have some benefits in the process in that it stabilizes the chelating agents, reducing degradation and thereby reducing chemical costs. On the other hand, too much thiosulfate requires the addition of caustic to maintain pH. Blowdown may be required to avoid salt buildup in the system.

Biocarbonate formation depends on the amount of carbon dioxide absorbed from the sour gas, which depends on the CO₂ partial pressure and the pH of the solution. There are no benefits to biocarbonate formation. Caustic must be added to maintain pH and some of the CO₂ is lost.



Merichem Chemicals & Refinery Services LLC
Gas Technology Products Division
846 East Algonquin Road, Suite A100
Schaumburg, IL 60173
Phone: (847) 285-3850
Fax: (847) 285-3888/3889
www.gtp-merichem.com

Japan Office:
Phone: (81) 3-5289-4530
Fax: (81) 33-255-5181

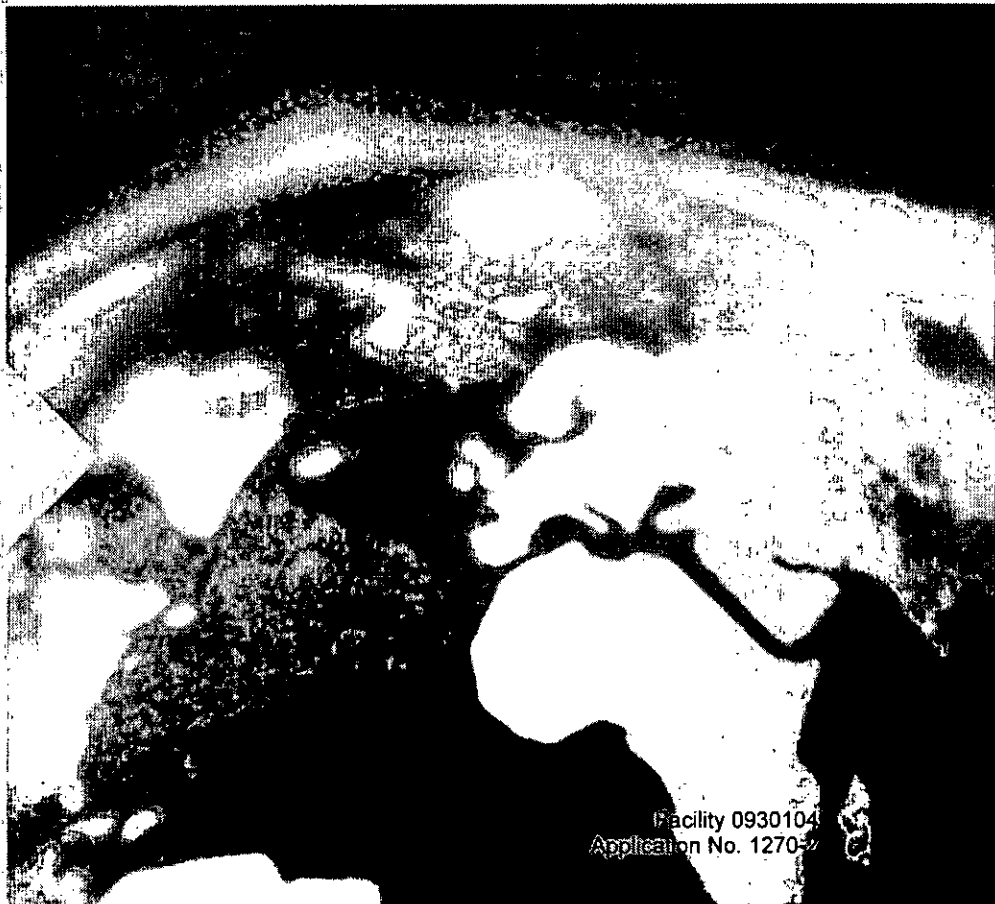

KNOCK OUT HYDROGEN SULFIDE WITH
MINI-CAT™



COMPLETE PACKAGED SYSTEMS
FOR COST-EFFECTIVE HYDROGEN
SULFIDE REMOVAL

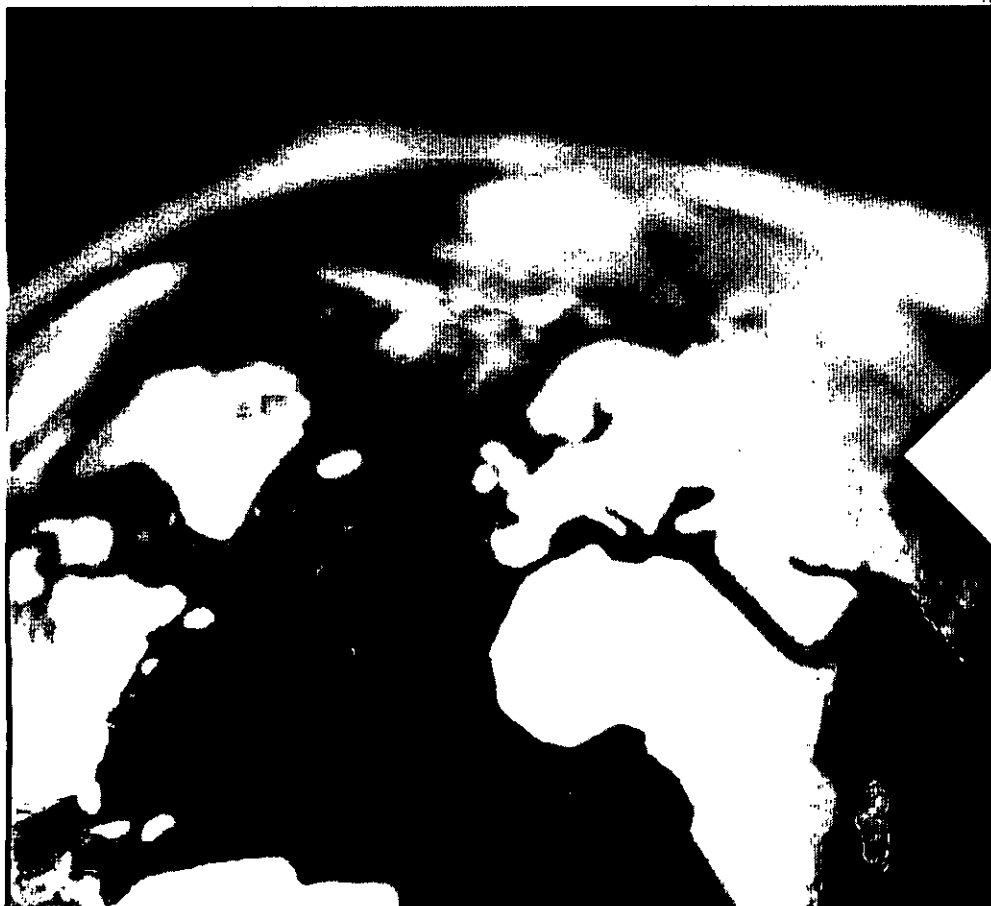

Gas Technology Products

Merichem Chemicals &
Refinery Services LLC
Application No. 1270-2

MINI-CAT™

SYSTEMS PROVIDE COST-EFFECTIVE H₂S REMOVAL IN LANDFILL GAS APPLICATIONS

MINI-CAT™ was born out of the LO-CAT® H₂S removal technology which treats sulfur loads between 1,000 kg/day and 25+ tons per day. With MINI-CAT™, Gas Technology Products is building on this tradition of simplicity and success by pre-engineering virtually the entire plant for sulfur loads between 200 - 1,000 kg/day.

With this simple change to a commercially successful technology in operations for 27 years, the result is nothing short of revolutionary. Capital cost may be reduced significantly compared to a similar custom designed unit. And delivery and installation time may be reduced by as much as 50%.

MINI-CAT™ is cost-effective in removing H₂S in numerous applications including landfills, municipal waste, and biogas treatment.

In comparison to old fashioned "scavenger" H₂S removal systems MINI-CAT™ will reduce chemical costs up to 80% (more if you use a liquid scavenger), continuously remove H₂S without unexpected sulfur breakthrough, eliminate the need for reactor change-outs, and cut waste products in half.

REMOVING H₂S FROM LANDFILL GAS (LFG)

Gas Technology Products offers a line-up of cost-effective, environmentally-friendly, and powerful H₂S removal systems that are adaptable to landfill gas treatment applications.

The MINI-CAT™ process, based on proven LO-CAT technology, treats smaller H₂S loads using the same chemistry as LO-CAT. However, MINI-CAT™ is especially attractive and cost-effective for many landfill gas applications as a modular option with lower capital cost than LO-CAT. MINI-CAT™ units are pre-fabricated, skid-mounted, have a small footprint, and offer expanded flexibility for variable landfill gas flows and H₂S concentrations.

MINI-CAT™ is a water-based H₂S removal process for landfill gas applications with higher H₂S concentrations. Typically, LO-CAT is used for removing 1,000 - 10,000 kg of sulfur per day as H₂S; MINI-CAT™ for removing 200 - 1,000 kg (440 - 2,200 lb) sulfur per day as H₂S.

The patented LO-CAT® (liquid oxidation catalyst) process uses an iron chelate solution to oxidize the H₂S to elemental sulfur and water. The iron chelate solution is then continuously regenerated using air, resulting in much lower operating costs than non-regenerable scavengers. The elemental sulfur product can be used

for agricultural applications—so it is not a waste product requiring disposal.

Different configurations are employed to yield better than 99.9% H₂S removal. In the mobile bed absorber configuration, moderately low pressure gas streams are contacted counter-currently with LO-CAT solution using spherical balls to aid in mixing. Venturi contactors are used for low pressure, high volume gas streams where the required sulfur removal efficiency is lower. In all configurations, the elemental sulfur is separated, the LO-CAT solution is regenerated with air in a separate Oxidizer vessel, and the solution is circulated back to the absorber.

To help determine the right process for your needs, use the following formulas:

$$((\text{SCFM gas flow}) \times (\text{ppmv H}_2\text{S}))/8225 = \text{lb/day sulfur}$$

$$((\text{Nm}^3/\text{hour gas flow}) \times (\text{ppmv H}_2\text{S}))/29671 = \text{kg/day sulfur}$$

REDUCED OPERATING COSTS

To illustrate typical savings in operating costs, consider the typical landfill sulfur generation profile below.

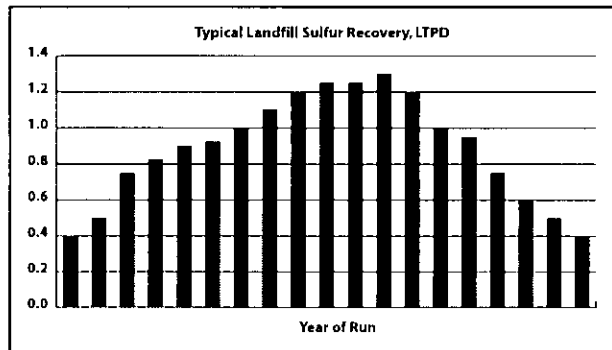

Cost savings, based on a twenty year operating cycle, are shown in the table below.

Technology Type	Capital Cost USD	Treatment Cost USD	Total Costs USD
Aerobic Iron Sponge	\$200,000	\$13,025,000	\$13,225,000
MINI-CAT	\$1,500,000*	\$1,450,000	\$2,950,000
		Savings:	\$10,275,000

* = installed cost

As the table indicates, the landfill operation would realize a savings of more than \$10,000,000 using MINI-CAT™ technology.

HOW MINI-CAT™ WORKS

The MINI-CAT™ process uses the same special form of chelated iron catalyst field-proven in the LO-CAT process. This liquid, aqueous solution sweetens sour gas, produced elemental sulfur. The overall reaction, using oxygen in the regeneration step, is shown below:

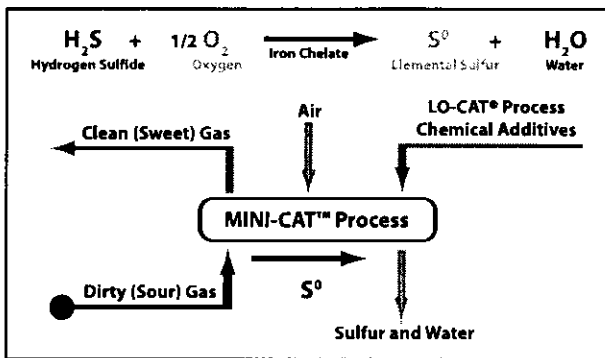

EASY OPERATION

Your operating time is greatly reduced with the MINI-CAT™ process. Typically, operators spend only thirty minutes each day taking chemical inventories and running basic field tests to determine the pH and Redox potential of the MINI-CAT™ solution. Gas Technology Products laboratory personnel will test the solution samples for iron concentration and chelate concentration to help you maintain proper solution chemistry.

THE MINI-CAT™ PROCESS

In the **gas contacting area**, gas is sweetened when it contacts the ferric iron chelate solution, creating a spent solution.

The **spent solution** is mixed with air, converting ferric iron chelate to a ferrous iron chelate solution, resulting in a **regenerated solution**.

The **regenerated solution** is clarified by decanting, cleaning the solution and thickening the solid sulfur particles.

In a final **solids filtration** step, the sulfur is filtered from the thickened sulfur particles.

Water and solid elemental sulfur are produced by the MINI-CAT™ process. Water is removed to preclude diluting the process solution, and sulfur is removed by filtering, so that this by-product can be sold as an agricultural feedstock—to be used as a fungicide, in direct soil applications.

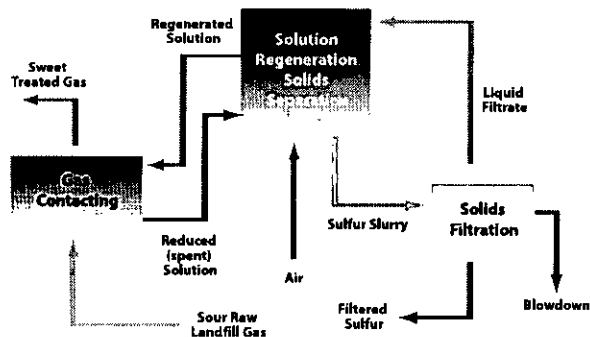



MERICHEM

Merichem Chemicals & Refinery Services LLC

Gas Technology Products Division
846 East Algonquin Road, Suite A100
Schaumburg, IL 60173

Phone: (847) 285-3850
Fax: (847) 285-3888/3889
www.gtp-merichem.com

Japan Office:
Phone: (81) 3-5289-4530
Fax: (81) 33-255-5181

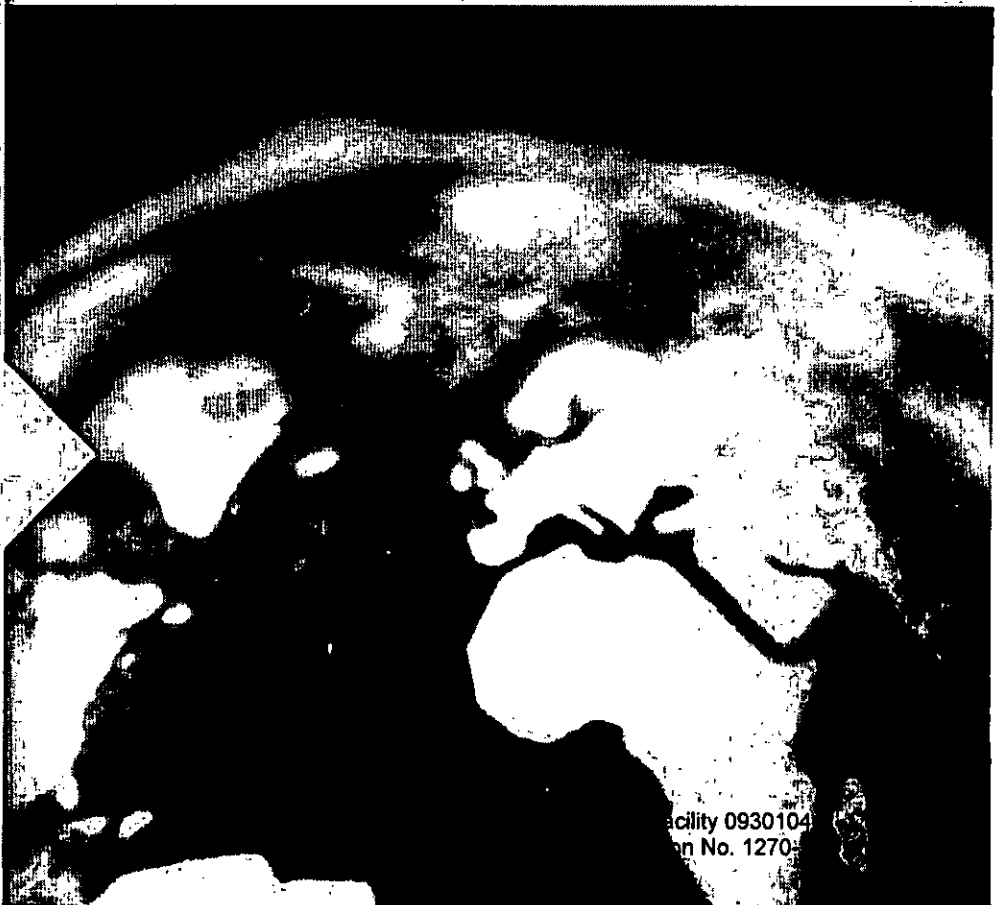

LFG COMBUSTION TURBINES
SOLAR MARS 100 TURBINES

Solar Turbines

A Caterpillar Company

MARS 100 Gas Turbine Generator Set

OIL & GAS

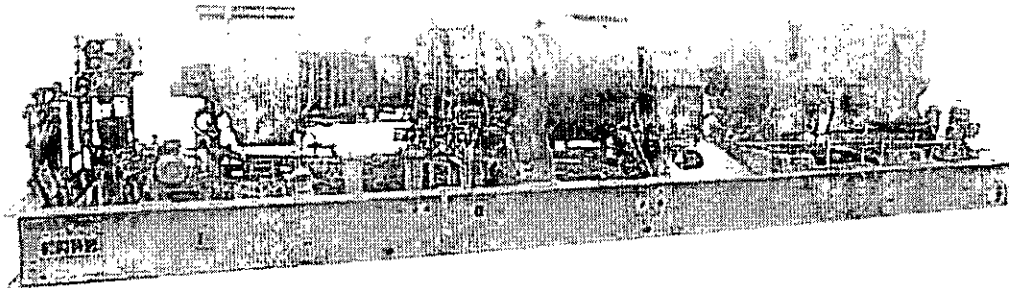

General Specifications

Mars® 100 Gas Turbine

- Industrial, Two-Shaft
- Axial Compressor
 - 15-Stage
 - Variable Inlet Guide Vanes
 - Compression Ratio: 17.4:1
 - Inlet Airflow:
41.3 kg/sec (91.0 lb/sec)
 - 100% Speed: 10,780 rpm
 - Vertically Split Case
- Combustion Chamber
 - Standard: Annular-Type (Conventional)
 - Optional: Annular-Type, Lean-Premixed, Dry, Low Emission (SoLoNO_x)¹
 - 21 Fuel Injectors (Standard)
 - 14 Fuel Injectors (SoLoNO_x)
 - Torch Ignitor System
- Gas Producer Turbine
 - 2-Stage, Reaction
 - 100% Speed: 10,780 rpm
- Power Turbine
 - 2-Stage, Reaction
 - Speed, 50-Hz Generator: 8625 rpm
 - Speed, 60-Hz Generator: 8568 rpm
- Bearings
 - Journal: Tilt-Pad
 - Thrust, Active: Tilt-Pad
 - Thrust, Inactive:
Fixed Tapered Land
- Coatings
 - Compressor: Inorganic Aluminum
 - Turbine and Nozzle Blades: Platinum Aluminide
- Vibration Transducer Type
 - Proximity Probes
 - Velocity Pick-up
- Main Reduction Drive
 - Epicyclic Type
 - 1500 or 1800 rpm
- Generator
 - Type: Salient Pole, 3-Phase, 6-Wire, Wye Connected, Synchronous, with Brushless Exciter

- Construction Options
 - Open Drip Proof
 - Weather Protected II (WPII)^{*}
 - Totally Enclosed Water/Air Cooled^{*}
- Sleeve Bearings
- Voltage Regulation
 - Solid-State Regulation with Permanent Magnet Generator
- Insulation/Rise Options
 - NEMA Class F with R Rise
- Voltages: 3300 to 13,800 Volts
- Frequency: 50 or 60 Hz

Package

- Mechanical Construction
 - Steel Base Frame with Drip Pans
 - 316L Stainless Steel Piping
 - Compression-Type Tube Fittings
 - Suitable for 3-Point Mounting
 - FPSO Modifications (Option)
- Electrical System
 - NEC, Class 1, Group D, Div 2
 - CENELEC/ATEX Zone 2
 - Conduit/Cable Tray Wiring
 - 120VDC Battery/Charger System
- Direct-Drive AC Start System
- Fuel Systems
 - Conventional Combustion or Dry Low Emission (SoLoNO_x)
- Fuel Types
 - Natural Gas or Dual (Gas/Distillate)
- Integrated Lube Oil System
 - Turbine-Driven Main Pump
 - AC Motor-Driven Pre/Post Pump
 - DC (120V) Motor-Driven Backup Pump
 - Oil Cooler and Oil Heater (Options)
 - Tank Vent Separator and Flame Trap
 - Lube Oil Filter
- On-Crank or On-Crank/On-Line Turbine Compressor Cleaning System (Options)
 - Portable Cleaning Tank (Option)

- Air Inlet and Exhaust System
 - Carbon Steel
 - Stainless Steel
 - Marine-Type Filters
- Enclosure (Driver Only or Complete)
 - Fire Detection and Suppression
- Factory Testing of Turbine and Package
- Documentation
 - Electrical Drawings
 - Mechanical Drawings
 - Quality Control Data Book
 - Inspection and Test Plan
 - Test Reports
 - Operation and Maintenance Manuals
- Digital Onskid Display Panel

Turbotronic® Control System

- Onskid Control System (Optional Offskid System)
 - 24 VDC Control Power (120VDC Input)
 - Serial Link Supervisory Interface
 - Field Programmable
- Vibration Monitoring
 - Turbine Bearings and Shaft
 - Gearbox
 - Generator Bearings
- Temperature Monitoring
 - Turbine Combustion Process
 - Turbine Bearings and Lube Oil
 - Generator Bearings and Windings
- Generator Control
 - Selectable Control Modes
 - Solid-State Voltage Regulation
 - Automatic Synchronization
 - Metering Panel with Manual Synchronization (Option)
 - KW Control (Option)
- TT4000 Display and Monitoring System
 - Multiple Operator Display Screens
 - Data Collection and Playback
 - Turbine Performance Map (Option)
 - Printer/Logger (Option)

^{*} Non-standard option

Solar Turbines

A Caterpillar Company

MARS 100 Gas Turbine Generator Set

OIL & GAS

Performance

Output Power Continuous Duty	10 695 kW _e
Heat Rate	11 090 kJ/kWe-hr (10,515 Btu/kWe-hr)
Exhaust Flow	149 930 kg/hr (330,180 lb/hr)
Exhaust Temp.	485°C (906°F)

Nominal Rating – ISO
At 15°C (59°F), sea level

No inlet/exhaust losses

Relative humidity 60%

Natural gas fuel with
LHV = 31.5 to 43.3 MJ/m³
(800 to 1100 Btu/scf)

Optimum power turbine speed

AC-driven accessories

Engine efficiency: 35.7%

15°C (59°F) turbine rating match

Other turbine rating match points available

Available Power

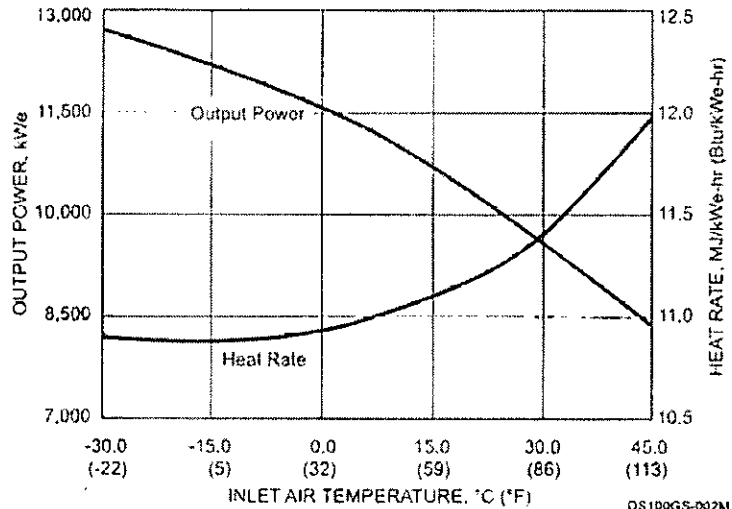

DS100GS-002M

Package Dimensions

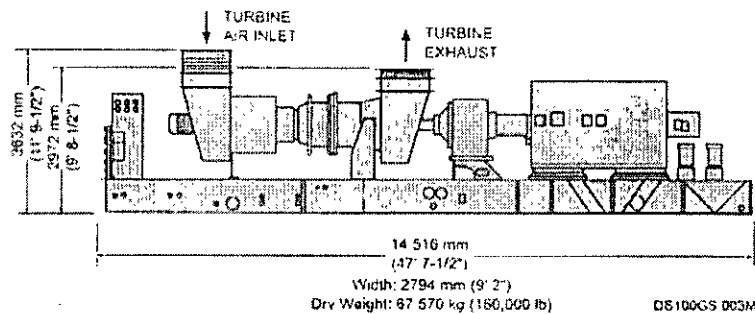

Solar Turbines Incorporated
P.O. Box 85376
San Diego, CA 92186-5376

Caterpillar is a trademark of Caterpillar Inc.
Solar, Mars, SoLARIO, and Turbosonic are trademarks of Solar Turbines Incorporated.
Specifications subject to change without notice. Printed in U.S.A.
© 2005 Solar Turbines Incorporated. All rights reserved.
DS100GS/005/ED

FOR MORE INFORMATION

Telephone: (+1) 619-544-5352
Telefax: (+1) 619-544-2633
Internet: www.solarturbines.com



SECTION II
APPENDIX H – DESCRIPTION OF CONTROL EQUIPMENT

- Landfill Gas Flares
- LO-Cat Desulphurization System
- Solar Combustion Turbines

(The following manufacturer's specifications are representative of the proposed equipment. It is expected that this equipment will be used; however, if through the procurement process, another manufacturer provides similar equipment that meets or exceeds the performance parameters used to develop the air emissions and air quality modeling in this AC permit application, a substitution may be made. The FDEP will be notified of any change at least 30 days prior to construction.)

LFG COMBUSTION TURBINES
SOLAR MARS 100 TURBINES

LANDFILL GAS FLARES

- Parnell
- PEI Perennial Energy
- LFG Specialties

OFFICE	DRAWN BY	CHECKED BY	APPROVED BY	DRAWING NUMBER
HOPKINTON, MA	KCK 08/12/05	KF 08/12/05	KF 08/12/05	836378A2-1B

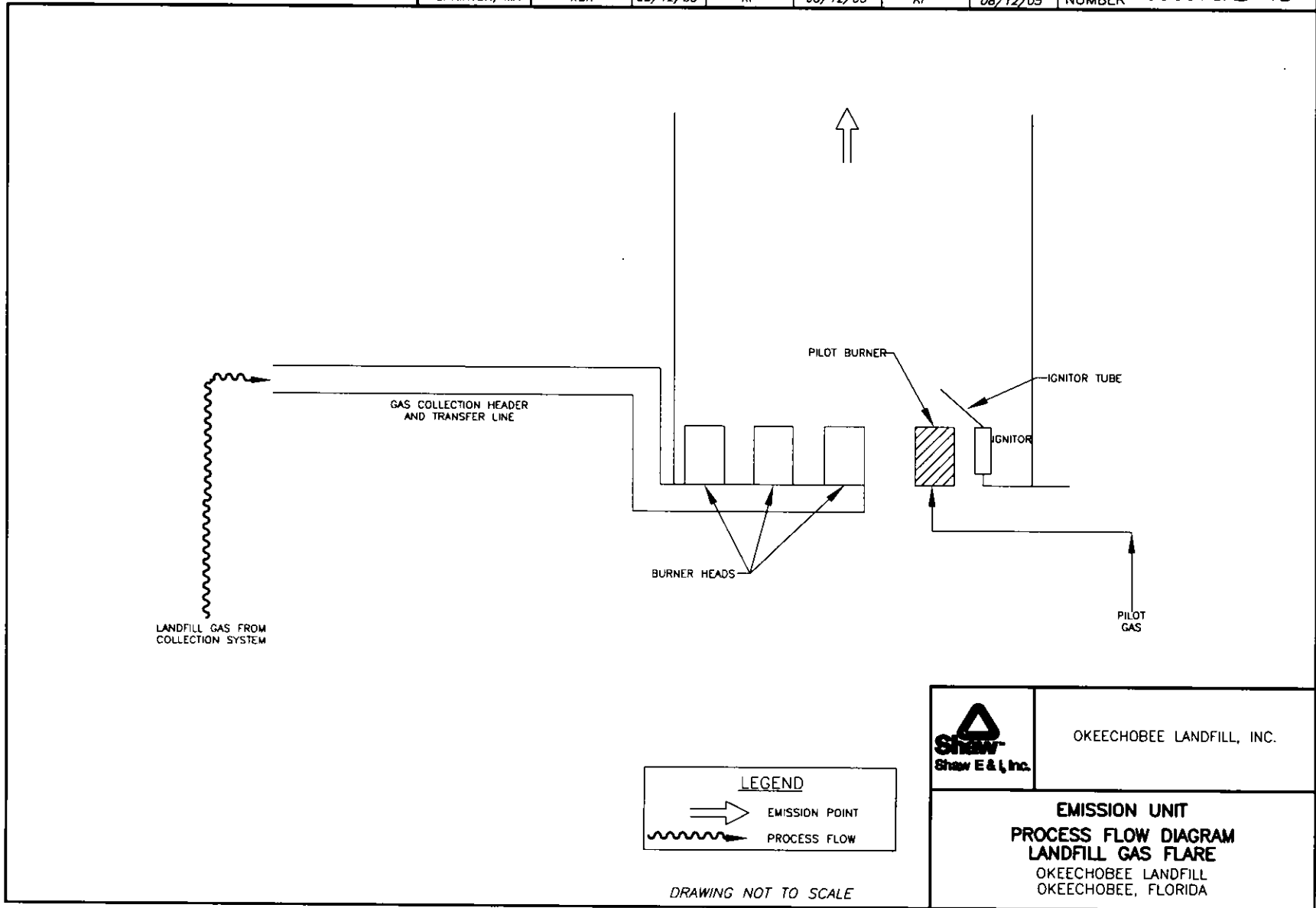

OKEECHOBEE LANDFILL, INC.

EMISSION UNIT
PROCESS FLOW DIAGRAM
LANDFILL GAS FLARE
 OKEECHOBEE LANDFILL
 OKEECHOBEE, FLORIDA

5868 S. 129th E. Ave.
Tulsa, Okla. 74134
918-294-3868 Fax: 918-294-9897



April 19, 2006

Carlson Environmental
358 Emerson Mill Road
Hampden, Maine
04444

Ph: 7045067312
Fax:

Attention: Miguel Delgado

RE: One 3000 scfm Skid-Utility Landfill Gas Flare System

Gentleman:

The solution to landfill gas control begins with selecting a company that specializes in just that! Parnel Biogas Inc. is dedicated to supplying quality landfill gas flaring equipment and service.

As a company Parnel Biogas Inc. offers:

- The latest and best available Landfill Gas Control Technology
- Flare performance guarantees
- Qualified service personnel
- And the commitment to respond to your Landfill Gas Flaring needs, immediately

Parnel Biogas Inc. Landfill Gas Flares meet the stringent operating requirements set forth by the major landfill operators. The flare combustion chamber is designed to provide the necessary residence time to completely combust the landfill gas. The control system is designed to operate one or two gas blowers and will operate the flare in manual and automatic in a trouble free and safe manner.

Parnel Biogas Inc. Proposal # 3232006-1

April 19, 2006

Page 2

Parnel Biogas Inc. though extensive field experience has improved on conventional flare designs in the following areas:

- Parnel Biogas Inc. Utility Flares are designed to prevent flame instability and flame lift off.
- Parnel Biogas Inc. Utility Flare tips are constructed of stainless steel with an integral flame holder to provide superior flame retention even in high wind conditions.
- State of the art PLC control burner management
- Guaranteed emission values
- The Parnel Biogas Inc. proprietary pilot is designed exclusively for Landfill Gas service to provide superior pilot performance and trouble free operation.

Parnel Biogas Inc. would like to earn the opportunity of being your preferred Landfill Gas Flare supplier. We enjoy discussing this proposal with you in detail at your convenience

Sincerely

Jeff Parker
Process Engineer

Process Specifications

Landfill Gas Flow rate (max)	3000 scfm
Landfill Gas Flow rate Flare (min Dependent on blower surge point)	
Blower Surge Point with 1500 scfm blowers	450 scfm
Flare exit velocity(not to exceed)	60.0 ft/sec
Landfill Gas Composition:	
Methane	50%
CO2, N2, O2, VOC's, H2O, H2S	50%
Heat Release (max)	81.9 MMBtu/hr
Inlet Pressure to flare	12" WC (approx)
Blower motor Horsepower	50 hp
Sight Elevation	1000 MSL
Design wind load per ASCE 7-93	110mph
Noise level at 3ft.	< 85dba
Design ambient air temperature	-30F to 110F
Electrical Area Classification	Non-hazardous

Expected Flow/Emissions at 3000scfm, 50% methane:

N2 73.5 % vol.
O2 13.6 % vol.
CO2 6.0 % vol.
H2O 6.9 % vol.
NO2 0.04 lbs/MMBTU
CO 0.15 lbs/MMBTU

Destruction efficiency at design flow with landfill gas methane content of 40% to 60%---98% overall destruction of total hydrocarbons.

Guaranteed to meet E.P.A. emission standards for landfill gas utility type flares. Designed in accordance of EPA established criteria for open flares 40 CFR 60.18

Parnel Biogas Inc. is pleased to submit the following proposal for the Skid-Mounted Landfill Gas Utility Flare System.

Utility Flare Stack and Skid

One (1) Skid-mounted 12" x 35' Flare stack constructed of A-53 sch.40 pipe, with 14" x 5' 304 Stainless Steel tip. Parnel Biogas Inc. 316 ss flame retention ring, 36" x 4' 316 ss 7ga. Windshield to help retain flame at the tip and provide retention time for efficient combustion.

One (1) 12" tee 150# flanged inlet with 1" drain connection

One (1) 12" flame arrestor aluminum construction and aluminum arrestor bank assembly.

One (1) Structural steel skid 8'x30' approx. with decking in accessible areas and galvanized.

One (1) Stainless steel Knock-out pot

Two (2) Landfill gas blowers HSI

One (1) 12" Pneumatic fail close valve

One (1) 12" Gear driven manual valve at KO pot inlet.

Two (2) Aluminum check valves

Four (4) Manual valves located at blower inlets and outlets

304 Stainless steel process piping for two blower system

Pilot and Igniter assembly

One (1) Parnel Biogas Inc. proprietary pilot assembly. The Pilot is constructed of 304 stainless steel with a 310 stainless steel tip.

CONTROL SYSTEM OPERATION (Generic)

The following is a brief outline of the control system operation:

System start-up (in the automatic mode) the pilot gas solenoid valve is opened to allow propane gas to the pilot assembly the igniter is pulsed to light the pilot tip. Once the pilot is detected, a signal is sent to the PLC to initiate the main flame light off sequence. Upon pilot prove the Landfill gas fail close valve is opened and the Landfill gas blower is started. Once the main flame is proved, the pilot is shut down to limit propane usage. Upon main flame loss both the waste gas valve would be closed and the landfill gas blower would be shut off. Automatic re-ignition will attempt resuming normal flare operation. If pilot re-ignition or main flame prove does not occur within a specified period of time the flare would shut down and a signal to a autodialer or alarm beacon if so equipped, to notify system operator of shutdown.

SKID-MOUNTED CONTROL SYSTEM COMPONENTS:

Master control cabinet including PLC, Yokogawa paperless chart recorder (WM standard), panel heater, interior panel light and controls needed for operation.

Pilot gas pressure control

Pilot and main flame detection

Motor starter panel including landfill gas blower variable frequency drives, blower control circuit breaker, step-down transformer.

All necessary lights and switches for proper operation of flare system in manual and automatic modes. Lamp test push button to confirm operation of panel lights.

Safety disconnect

One (1) 480v/110v step down transformer

One (1) 15amp convenience outlet

One (1) 100 watt skid light with manual and photocell control

Nitrogen and propane bottle holders (propane bottle holders sized for two 10lb. size bottles)

One (1) Safety Disconnect

One (1) Flash back detection for flame arrestor

Temperature, vacuum and pressure gauges with block and bleeds

VFD controller

One (1) System vacuum transmitter

One (1) Autodialer with cellular capabilities. (Customer supplies cellular carrier and type of service information)

Per Flare System:

FLAME ARRESTOR

One (1) 12" Eccentric Flame arrestor all aluminum construction with flash back detection.

FAIL-CLOSE VALVE

One (1) 12" Xomox fail close high performance butterfly valve. Valve has carbon steel body, 316ss disk, PTFE seals, pneumatic actuator, 3-way Asco solenoid valve, and speed control.

LANDFILL GAS BLOWER

Two (2) HSI Centrifugal Landfill Gas blower with at combined design flow rate of 1500 scfm @ a minimum of -60" wc inlet suction and 15"wc discharge pressure. Blower will be belt driven and supplied with a 50 hp inverter duty TEFC motor. All would be mounted on a unitary base and factory aligned. Blower would include coated internals, BUNA "N" shaft seals, Type B spark resistant, current transformer with ammeter, Inlet vacuum and outlet pressure gauges, outlet temperature gauge.

KNOCK OUT POT

One (1) 3' x 6' 304 stainless steel knock out pot with 14" inlet and 12" outlet. Removable lid, PVC sight glass, 2" PVC drain with valve, level switch, dp gauge across demister pad, two sample ports with ball valves with hose barb ends for remote pressure drop measurement and a integral stainless steel demister pad, differential pressure indication.

THERMAL FLOWMETER

One (1) Thermal flow meter 1/2" OD, 316ss, 1/2" NPT mounting connection, and electronics installed. The thermal meters have digital displays for instantaneous flow and totalization are not susceptible to ambient temperatures or dirty working environments. This Flowmeter retains its accuracy over the full range of flow rates, unlike the orifice plate system.

Parnel Biogas Inc. Proposal # 3232006-1

April 19, 2006

Page 7

PRICING

One Parnel Biogas Inc. standard 3000scfm Skid-Mounted Utility Landfill flare systems. One 12"x 35' flare, 14" stainless tip, Knock out pot, blower motor and control system, flame arrestor, fail close valve, 304 Stainless steel process piping three (3) operating manuals each flare, three days startup. All factory tested to the fullest extent possible.

FIRM PRICE\$

OPTIONS

- One (1) Honeywell circular chart recorder in place of Yokogawa paperless.....deduct \$ 1000.00
- One (1) VFD drives for blowers with transmitter and controller..... \$ Included
- One (1) Cellular ready Autodialer system..... \$ Included
- One (1) 12" Flame arrestor..... \$ included
- One (1) 12" Xomox pneumatic fail close valve..... \$ Included
- One (1) Knock-out pot 3' x 6' HPDE..... \$ included
- One (1) KO pot level switch for system shut down..... \$ included
- One (1) FA flash back protection..... \$ included
- Freight not to exceed..... \$ 6000.00
- System Start-up and travel expenses included for each system..... \$ included

RECOMMENDED SPARE PARTS

Two (2) Thermocouple assemblies

SPARE PARTS PRICE..... \$ 650.00

**Systems can be shipped 12-14 weeks after receipt of purchase order.
Depending on blower delivery.**

Parnel Biogas Inc. field service rate: \$800.00 a day plus expenses

If customer drawing approval is needed this would extend shipping date.

The following are to be provided by the customer:

Receiving, unloading, inspection of equipment

Interconnecting piping from Landfill header to equipment

Erection and installation of all equipment

Pilot gas propane supply and piping

Foundation design

Electrical service connection

The following are to be provided by Parnel Biogas Inc.

General arrangement drawings

P&ID's

Electrical interconnect drawings

Sufficient details for assembly

Shipping Lists

Instrument and equipment specifications

Three copies of operations manuals

Parnel Biogas Inc.
Sales inside the US

FOB POINT: All equipment is FOB Point of Manufacture

This proposal is void after 45 days. Acceptance of any order is at the sole discretion of Parnel Biogas Inc. Credit approval and agreement by the buyer to Parnel Biogas Inc. Terms and conditions

Pricing: Pricing quoted in this proposal is based on the total quantity of items being offered. Partial orders or changes in quantity may necessitate a change in pricing unless stated otherwise in the body of this proposal. No taxes or duties are included in pricing. Pricing is based upon the specifications provided to Parnel Biogas Inc. by the customer and referenced in this proposal. Additions to or changes will result in changes in pricing. The pricing presented in this proposal is based on the following payment terms.

35% upon receipt of purchase order
25% upon submittal of drawings
25% upon start of fabrication
10% upon Half-fabrication
5% upon notification to ship

Invoices: Invoices are due net 30days. Past due invoices will be charged interest at prime plus 1.5%.

Delivery: The delivery dates presented in this proposal are preliminary. The actual dates are variable dependent on variables at the time of the order and will also be affected by (1) SCOPE CHANGES MADE BY THE BUYER (2) DELAYS BY THE BUYER IN APPROVING DRAWINGS (3) OR ANY OTHER DELAYS BY BUYERS IN PERFORMING ITS OTHER OBLIGATIONS UNDER THIS ORDER.

TERMS AND CONDITIONS

LIMITATIONS OF LIABILITY: Under no circumstances shall Parnel Biogas Inc. be responsible for loss of use/loss profit, incidental, consequential, indirect, or special damages, nor shall Parnel Biogas Inc. total aggregate liability under this purchase order exceed the value of the purchase order.

WARRANTY: Parnel Biogas Inc. warrants the equipment to be free from defects in material or workmanship for 18 months from date of notification to ship or 12 months after start-up whichever occurs first. Vendor-supplied items will carry standard vendor warranties, which will be transferred to the end user. This warranty shall be for repair or replacement, at Parnel Biogas Inc. option, of any defective parts, FOB point of manufacture. All cost for labor, equipment, and/or material costs for removal and/or reinstallation of parts, are expressly excluded for this warranty

ALL WARRANTIES SHALL BE VOIDED, AND BUYER AGREES TO INDEMNIFY AND HOLD Parnel Biogas Inc. HARMLESS FROM, ANY CLAIM OF LIABILITY BY ANYONE IF: (1) ANY REPAIRS, ALTERATIONS, MODIFICATIONS, OR DISASSEMBLIES ARE MADE WITHOUT Parnel Biogas Inc. APPROVAL OR IN VIOLATION OF THE OPERATING MANUAL INSTRUCTIONS; (2) ANY REPLACEMENT PARTS ARE USED ON THE EQUIPMENT OTHER THAN THOSE SUPPLIED OR APPROVED BY Parnel Biogas Inc.; (3) THE EQUIPMENT IS USED FOR ANY OTHER USE OR MANNER THAN IT WAS ORIGINALLY DESIGNED (4) OR SYSTEM IS NOT OPERATED IN STRICT ACCORDANCE WITH THE MANUAL. The above warranty is the sole and exclusive guaranty and warranty provided by Parnel Biogas Inc. and all other warranties or guarantees (express, implied, in law or in equity, including warranties of merchantability and fitness for a particular purpose) are hereby disclaimed and excluded. Parnel Biogas Inc. total aggregate liability with regard to warranties shall not exceed the order amount.

CHANGES Many small changes may significantly affect both price and schedule. A design freeze will be placed on the project prior to release for fabrication and the buyer notified of this date. If the buyer desires to make changes in quantities or goods or work, in specifications or drawings governing the goods of the work, or otherwise amend or modify the Purchase Order, it shall deliver a change order to Parnel Biogas Inc. If within 30 days the buyer and Parnel Biogas Inc. are unable to reach an agreement regarding changes in Price or time of delivery, this Purchase Order shall remain in effect as originally issued. And any time used in attempting to resolve the problems in design shipping date ect. Will be automatically added to the buyer's delivery date. Any changes made after the design freeze may incur additional costs to the buyer and have effects of the shipping date.

PATENTS Under no circumstances, shall a patent infringement indemnity granted by Parnel Biogas Inc. if any, apply to any equipment, or any part thereof, manufactured to buyers design or to changes in Parnel Biogas Inc. design requested by the buyer. As to such equipment or part, Parnel Biogas Inc. assumes no liability whatsoever for patent infringement. Further, such an indemnity, if any, will be expressly conditioned upon the buyer's agreement to notify Parnel Biogas Inc. of any claim of suit or proceeding in which such infringement by the buyer is alleged, and buyer, shall permit Parnel Biogas Inc. to control completely the defense of compromise of any such claim, suit, or proceeding, and buyer shall render such reasonable assistance in the defense thereof as Parnel Biogas Inc. may require

CANCELLATION Any Purchase Order resulting from this proposal may be cancelled by the buyer for its convenience by giving Parnel Biogas Inc. written notice of such cancellation. Upon receipt of such notice Parnel Biogas Inc. shall cease all of its own activity (except that related to the cancellation) and terminate under the most reasonably favorable terms all related subcontracts, as soon after such cancellation as reasonably practicable. Buyer shall pay the greater of (a) 25% of the total purchase order value or (b) Parnel Biogas Inc. costs incurred for this order to the point of cancellation, plus costs incurred in the termination of related subcontracts (including reasonable cancellation charges actually paid by Parnel Biogas Inc. to its sub suppliers and reasonable costs incurred in preserving and protecting materials, work in progress, and completed goods), plus a reasonable allowance for overhead and profit on such costs, whichever is greater. However, in no event shall the amounts payable to Parnel Biogas Inc. in the cancellation under this paragraph exceed the total price of this order, less payment previously made by buyer to Parnel Biogas Inc. under this order.

INDEMNITY under no circumstances will Parnel Biogas Inc. indemnify buyer or other party for claims or losses which are not caused by the negligence or willful misconduct of Parnel Biogas Inc.

ALTERNATE DISPUTE RESOLUTION If a dispute arises concerning or related to this agreement, it is the express intent of the parties hereto that they both commit to enter into good faith efforts to resolve the dispute at a meeting or meetings in which officials from both parties who have the authority to settle the dispute shall participate. The purpose of such negotiations will be an honest effort to allow each party an opportunity to determine if the dispute is resolvable prior to expensive and lengthy litigation. The parties shall have complete discretion as to what procedures shall be used and what agenda shall be discussed. Any such negotiation or series of negotiations shall be held as confidential by all parties, and the parties hereto do commit themselves that they shall not disclose either the existence of such proceedings or the content thereof. Any participation in or initiating of such discussions shall not be deemed to be admission of liability, and no statement made or provided in or related to such negotiations shall be construed as a statement against interest or otherwise disclosed or used in any proceeding involving the two parties.

If the dispute cannot be resolved at such meeting or meetings of senior officials, the parties agree to submit the dispute to nonbonding mediation by a mediator mutually selected by the parties. If the parties are unable to agree upon a mediator, then the mediator shall be appointed by the American Arbitration Association. In any event, the mediation shall take place within thirty (30) days of the date a party gives the other party written notice of its desire to mediate the dispute. The parties agree to start these negotiations prior to litigation being filed (injunctive relief exception) They will in no event start later than four (4) after litigations filed. If the party failing to participate in such meetings and mediation prior to litigation being filed is the party who filed the litigation, the party failing to participate in such meetings and mediation being filed shall be liable to the other party for the reasonable attorney costs and expenses of the other party for the reasonable attorney costs and expenses of the party incurred in seeking a stay of litigation pending the conclusion of such meeting and mediation.

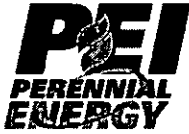

April 18, 2006

Carlson Environmental Consultants, PC
400 West Windsor Street
Monroe, NC 28112

Re: Burman Rd. Landfill (Okeechobee, FL)

Attn: Mr. Kris Carlson

Kris::

Per your request, following and attached please find our quotation to supply the described products and services relative to your Burman Road Landfill project requirements. We appreciate the opportunity to furnish this proposal.

PEI proposes to provide a unitized, modular, landfill gas candlestick flare station including all components necessary for a complete and operational system, with off-loading and installation by others. The flare station shall be sized per your request for quotation to handle **450 to 3000 SCFM** of landfill gas at **-60" WC** vacuum. The system is designed with two **1500 SCFM** blowers, and all appurtenant sub-systems to provide a fully functional system, including the **3000 SCFM** Candlestick (utility) flare.

The Candlestick Flare Station (CSFS) shall include three principal sub-systems:

- o The Candlestick Flare
- o The Gas Handling System (GHS)
- o The Candlestick Flare Station MCC/Control System

Not included in this proposal are the following:

- o Off-loading or Installation
- o Site civil or structural engineering
- o Bonds or liquidated damages

The Candlestick Flare shall include:

- o PEI 12" Candlestick flare assembly for 450 to 3000 SCFM LFG
- o 12" schedule 40 carbon steel lower mast assembly
- o 12" schedule 40 stainless steel upper mast assembly
- o 12" IPS – ANSI 125# flanged Inlet Nozzle
- o 12" Varec or Enardo all aluminum flame arrester

- 6" butterfly valve w/pneumatically controlled safety shutoff actuator w/spring assisted shutoff
- ¼" SS ball valved test ports up and downstream of flame arrester
- Valved flame arrester drain
- Stainless steel flare shroud assembly w/ operator adjustable air inlet louvers
- Stainless steel burner nozzle assembly w/ operator adjustable turbulator vanes
- Flare back pressure safety monitoring and shutdown
- Propane pilot assembly, including solenoid, regulator & manometer port
- All flare wiring pre-installed and pre-conduited
- Type "K" flame monitoring thermocouple assembly
- Flare mounting remote for GHS system skid, interconnecting piping included

The Gas Handling System shall include:

- 14" schedule 10 stainless steel (304L/316L) inlet piping
- Schedule 10 304L/316L weld hub assemblies w/ ANSI pattern coated carbon or ductile iron backing flanges
- 14" ANSI pattern flanged inlet nozzle assembly
- 12" suction and discharge header assemblies
- 10" butterfly blower inlet valves w/ SS disc & stem and Buna N elastomerics and lever handles
- 10" butterfly blower outlet valves w/ SS disc & stem and Buna N elastomerics and lever handles
- 10" check valves at the discharge of each blower
- Vacuum & Pressure gauges at the suction and discharge headers of system
- Vacuum & Temperature gauge at inlet of system
- Plugged test ports at system inlet and flare inlet
- Parallel HSI 8103 multistage centrifugal landfill gas blowers, each rated at 1500 SCFM. Provided with coated cast iron heads and sections and aluminum impellers
- 40 HP TEFC motor, 480 VAC, three phase, 60 hertz VFD duty motors

- 40 HP ABB variable frequency drives (VFD) for each blower
- All carbon steel surfaces sand blasted to SSPC SP-6 standards, primed and painted to PEI standard paint specs.
- Schedule 10 SS piping, minimum 10 upstream and 5 downstream diameters for flow tube
- PEI Landfill gas flow meter system with output through PLC to touch screen

The Candlestick Flare Station MCC/Control System shall include:

- 2-Bay NEMA 4X stainless steel MCC/control panel w/ NEMA 4 gasketing & 3 point latching
- NEMA 3/3R Weather / Heat radiation protection
- Control panel lighting
- Automation Direct PLC digital and analog logical supervision system
- Touch Screen operator interface system
- Remote communication modem system
- TELCO line surge protection
- Telephone installed in control panel
- 4 Channel Auto Dialing Alarm System (ADAS)
- Alarm and shutdown message annunciation (Touch Screen)
- TEST / OFF / Auto switch for the System
- OPEN / CLOSED / AUTO switch for the safety shutdown valve
- TEST / CONTINUOUS / AUTO switch for the propane pilot ignition system
- TEST / OFF / AUTO Switches for the blowers
- Flame failure annunciation for the flare (Touch Screen)
- Shutdown Valve failure annunciation (Touch Screen)
- Low LFG flow rate annunciation (Touch Screen)
- Surge protection and safety shutdown

- Flame failure reset (ALARM RESET / LAMP TEST switch)
- 200 A, 480 VAC, 3 phase service entrance protection
- 100 A 3 pole breakers for blower motors (52A NEC FLA)
- 20A 1 pole breaker for duplex convenience outlet
- 10A 1 pole breaker for controls circuit
- 10A 1 pole breaker for panel lighting, etc.
- AC and DC control voltage surge protection

General:

- 3 days of on-site start-up & training services by a factory field services technician/engineer are included.
- System is priced on an FOB Factory, West Plains, MO basis. Freight can be pre-paid and added to invoicing @ 110% of freight invoices.
- 3 copies of full engineering submittals are included.
- 3 copies of "as-built" Operation & Maintenance Manuals are included.

The system as described above and attached is provided as completely pre-packaged, pre-wired, and factory pre-tested as is possible. The system is offered FOB Factory, with freight billed at 110% of shipping invoice(s). Estimated freight costs are \$6,050.00.

The pricing does not include any site civil or structural engineering, or site preparation work of any kind. Neither does the price include any local, state or federal taxes, or any permits, or tariffs of any kind. The system as quoted is to be off loaded, set in place, installed and interconnected by others. The system is designed for installation on equipment pad(s) installed at the same finished elevation. The system includes only the standard PEI warranty for 18 months from date of shipment or 12 months from date of first service, whichever occurs first. Please see copy of PEI warranty, attached. We are pleased to honor this quotation for 30 days from the date of this document. The pricing is dependent on receiving an approved order that would include industry standard commercial terms. PEI standard terms are:

- 10% with order
- 30% with approved submittals
- 55% upon shipment
- 05% upon successful start-up, unless failure to achieve successful start-up is neither the fault nor cause of PEI, then net 60 days of shipment

The system as described above and attached is offered for

Based on the long lead item quotations we have received from vendors, we anticipate that we could ship the system **16 to 18** weeks from receipt of approved submittals or other irrevocable release to order all materials. Actual shipping estimates will have to be given at time of order. We anticipate that submittals can be provided in **4 to 5** weeks from receipt of an approved order.

Thank you for your consideration of PEI landfill gas products and services. Should you have any questions, or require further information in this regard, please do not hesitate to call.

Respectfully,

**PERENNIAL
ENERGY**

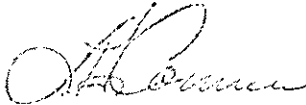

Larry H. Conner
Vice President

Attachments / Enclosures:

PEI Warranty / Service Policy and Conditions of Sale



CONDITIONS OF SALE and WARRANTY and SERVICE POLICY

1. SHOP DRAWINGS PEI will prepare shop drawings and specifications describing the equipment to be provided (when required) under this Contract. PEI shop drawings, specifications and equipment data will be provided utilizing standard PEI packaged, modular design and reflect standard PEI design and manufacture for PEI equipment as purchased. Sufficient information will be provided to illustrate major components of assemblies, standard controls (where applicable), basic materials and any special accessories or optional items. Three (3) copies of engineering submittals are provided. Extra sets are extra cost. PEI assumes no responsibility for design and/or performance of equipment manufactured from designs provided by others. Shop drawings shall be returned approved, or approved as noted, prior to commencement of component procurement or manufacture. PEI shall not be responsible for determining or verifying field conditions, or coordination with equipment or material provided by others.

All drawings, diagrams, specifications and technical data provided the Purchaser by PEI shall remain property of PEI and shall not be assigned, transferred, copied or applied to similar situations without express written consent of PEI.

2. O&M MANUALS PEI will provide 3 complete O & M Manuals for all equipment/systems provided. Additional sets are extra cost.

3. DELAY PEI shall not be responsible for delay in performance due to accidents to plant or causes beyond its control. PEI will provide purchaser prompt notice of any such delay and the time for performance by PEI shall be extended accordingly. If delay, through no fault of PEI, caused by lack of performance on part of Purchaser exceeds 30 days, Purchaser agrees to compensate PEI for increased costs in material and/or labor associated with such delay.

4. DELIVERY PEI will ship equipment in accordance with pre-agreed schedule with Purchaser. If Purchaser is unable to accept shipment on the pre-agreed date, PEI shall bill for payment due upon shipment and place equipment in storage. If shipment is not made within 14 days after placement in storage, appropriate storage charges will be assessed and purchaser agrees to pay such charges as billed monthly.

5. START-UP PEI will provide start-up services (where included) of a qualified technician(s) at Project field site for the period as stated. Start-up services include all costs associated with such service: travel, lodging, per-diem, labor and normal equipment. Additional services, extended periods or training are not included and shall be negotiated on an as-needed basis.

6. WARRANTY PEI warrants its System to be free from defects in materials and labor for a period of one year after being placed in service or eighteen months from date of shipment, whichever occurs first. Stainless steel enclosed flare burners are warranted against defects in design and/or manufacture for two years after being placed in service or thirty months from date of shipment, whichever occurs first.

All of the components not manufactured by PEI carry their own manufacturers warranty. In no way does PEI warranty override, supersede, or limit those warranties. With respect to products, parts and work not manufactured or performed by PEI, PEI's only obligation shall be to assign to Purchaser, to the extent possible, whatever warranty PEI receives from the original Manufacturer. PEI will attempt to aid the Purchaser in obtaining replacement parts or repair of the component as outlined in our Service Policy. The liability of PEI shall not, in any case, exceed the cost of correcting the defect in the component and PEI shall not be liable for indirect or consequential damages as a result of any component failure.

PEI warrants only the cost of parts and labor for repair of design and/or workmanship defects, and is not responsible for any damage and/or loss caused by the system to any personal or real property. PEI is not responsible for premature wear or failure of gas train components caused by hydrogen sulfide in excess of 1500 ppm, or chlorinated hydrocarbons in excess of 35 ppm. PEI is not responsible for any special, direct, indirect, or consequential damage or loss of income or saving due to down time on other components which rely on the System.

PEI's warranty shall not apply if damage results from maladjustment, abuse, inadequate maintenance, accident, or improper service or installation.

This warranty does not include reimbursement of any costs for shipping the product or parts to PEI facility or local designated service establishment, or for labor and/or material required for removal or reinstallation of a product in connection with a warranty repair. In no event shall PEI be liable for cost of labor for replacement or repair of defective parts when the unit has been in the possession of the Purchaser for a period longer than one year.

This warranty is in lieu of all other warranties, expressed or implied, including warranties of merchantability or fitness for a particular purpose, any legal implied warranty of fitness, merchantability or otherwise applicable to this product shall be limited in duration to the minimum period already set forth. This warranty gives the Purchaser specific legal rights; you may also have other rights which vary from state to state. Any claim by the Purchaser shall be submitted to PEI in writing during the warranty period.

7. SERVICE POLICY If repair service is required during the Warranty period, the Purchaser should first call PEI's Service Department and explain the nature of the problem. If the problem is minor, and the Purchaser is willing and able to correct it, then PEI will supply instructions. If this process is unable to correct the problem, then a service technician should be contacted by the Purchaser to do the repair work. PEI will supply maintenance instruction as needed, by phone. If the problem is determined by PEI to be related to the design or workmanship of the system, then PEI will pay reasonable, pre-approved, charges for material and labor for repair. The Purchaser shall pay the technician directly, and submit a warranty claim to PEI for reimbursement of materials and labor. In all other cases, the Purchaser is responsible for labor costs.

In the case of component failure, PEI will aid the Purchaser by providing the required part the same day (if in stock). An invoice for the part and shipping will be sent with the part. The Purchaser returns the defective part either to the original manufacturer or to PEI (depending on the circumstances) for determination of the cause of failure. An RGA (Returned Goods Authorization) number will be issued, which must appear on the return shipping label. If the part proves defective and is covered by the original manufacturers warranty, then the Purchaser will be credited for the invoice that was sent with the new part, but shall be responsible for the shipping costs.

If repair service is required after the warranty period has expired, the Purchaser is responsible for parts, labor, and shipping costs. PEI Service Department is available during normal business hours to provide assistance with service and maintenance to allow maximum equipment efficiency and service life.

-end-

HSI 8I SERIES

MULTISTAGE CENTRIFUGAL BLOWER

SPECIFICATIONS

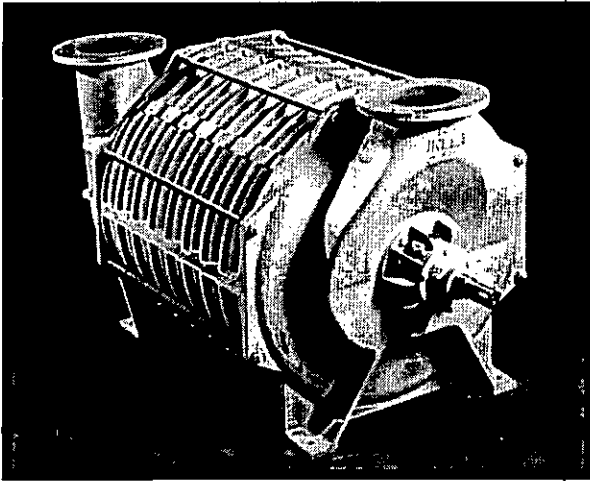

GENERAL PERFORMANCE

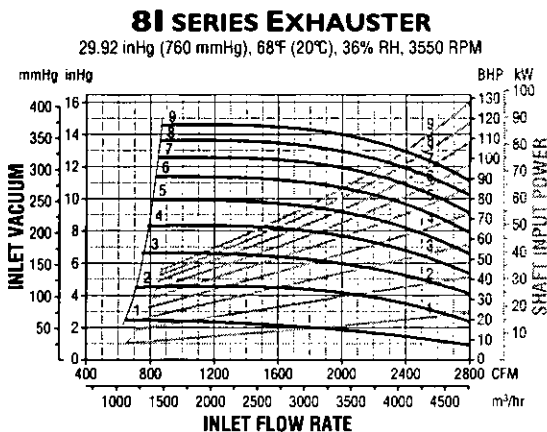
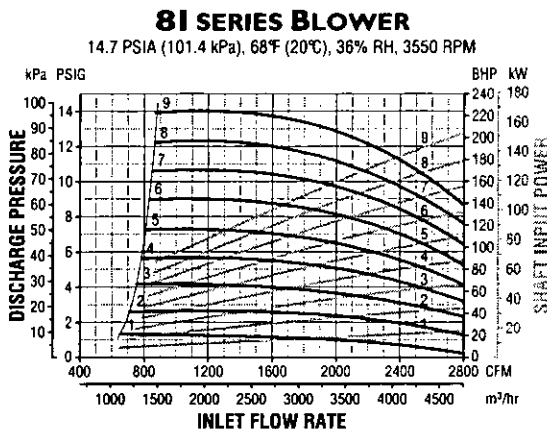

TECHNICAL DATA

Number of Stages	1 through 9
Inlet Connection	8" (203.2 mm) flange, ASA 125# drilling
Outlet Connection	8" (203.2 mm) flange, ASA 125# drilling
Operating Speed	3550 RPM (60 Hz), 2960 RPM (50 Hz)
Casing Pressure (max.)	20 PSIG (1.41 kg/cm ²)
Seals (air)	Labyrinth type
Seals (gas)	Stuffing box type (special seals available)
Bearings	Ball, 10-year minimum life per AFBMA L ₁₀ standard
Lubrication	Grease (standard) or Oil
Impeller Diameter	24.10 in (612.1 mm)
Impeller Tip Speed	373 ft/s (114 m/s) @ 3550 RPM
First Critical Speed	4701 RPM (9-stage)
Drive Type	Direct coupled or Belt driven, Inlet driven (standard) or Outlet driven
Shaft End	1.875 in (47.63 mm) diameter at coupling
Vibration Tolerance	25 in/s (6.4 mm/s) ISO overall specification, 1.25 mils (0.03 mm) peak to peak
Rotor Balance	Individual impellers statically balanced and complete rotating assembly dynamically balanced

MATERIALS OF CONSTRUCTION

Casing	Cast iron ASTM A48 grade 30
Bearing Caps & Housings	Cast iron ASTM A48 grade 30
Oil Reservoir	Cast iron ASTM A48 grade 30
Shaft	Carbon steel AISI 4140 (stainless steel available)
Impellers	Cast aluminum ANSI AA319
Seals (air)	Cast iron ASTM A48 grade 30 with lead babbitt insert
Seals (gas)	Cast aluminum ANSI AA319 stuffing box with braided packing
Tie Rods75 in (19.1 mm) diameter, high strength steel ASTM A193-B7
Blower Base	Welded structural steel
Motor Pedestal	Welded steel plate
Joint Sealing Compound	RTV silicone
Base Isolation Pads	Neoprene rubber
Finish	Two-part epoxy ASA61 gray

Note: Specifications subject to change without notice.

81 SERIES MULTISTAGE CENTRIFUGAL BLOWER

INLET & OUTLET ORIENTATION OPTIONS

The orientation of the inlet and outlet is selectable from any of three different positions, as viewed when facing the exterior of the part:

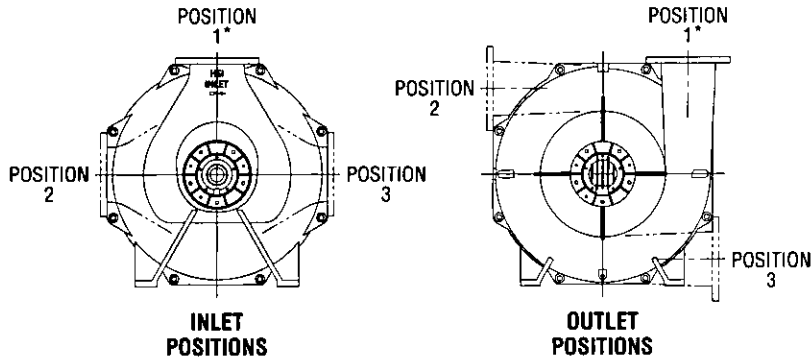

*Standard configuration.

WEIGHT & INERTIA

Model	Weight*		Wk ²	
	lb	kg	lb-ft ²	kg-m ²
8101	560	254	13	0.55
8102	860	390	23	0.97
8103	1160	526	33	1.39
8104	1460	662	43	1.81
8105	1760	798	53	2.23
8106	2060	934	63	2.65
8107	2360	1070	73	3.08
8108	2660	1207	83	3.50
8109	2960	1343	93	3.92

*Approximate weight for blower only.

GENERAL ARRANGEMENT

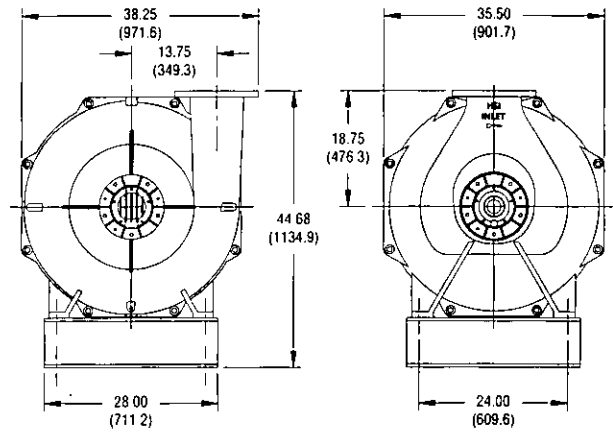
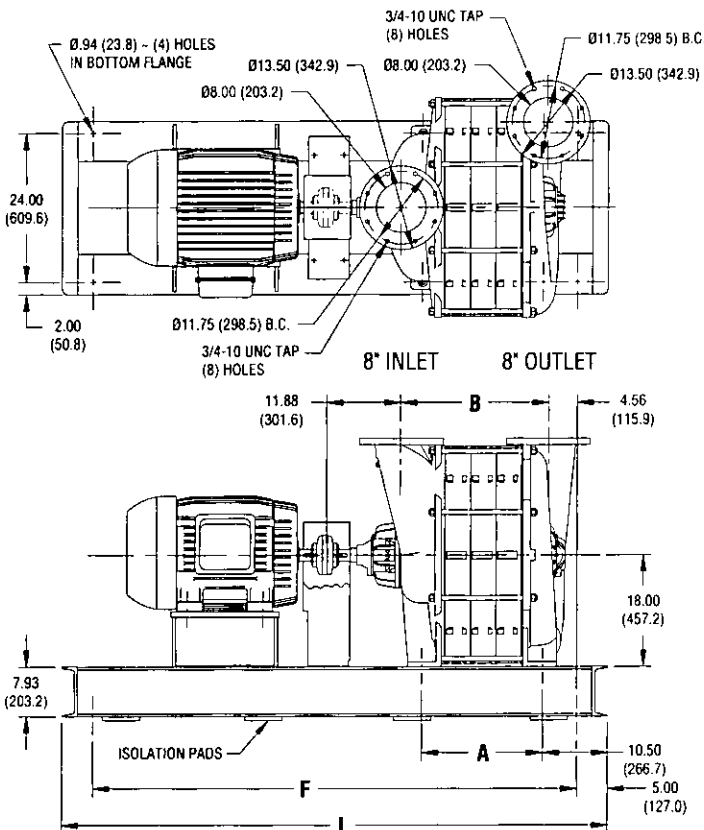

Model	Dimensions*			
	A	B	F [†]	L [†]
8101	7.13 (181)	11.56 (294)	52 (1321)	62 (1575)
8102	11.25 (286)	15.69 (398)	58 (1473)	68 (1727)
8103	15.38 (391)	19.81 (503)	65 (1651)	75 (1905)
8104	19.50 (495)	23.94 (608)	78 (1981)	88 (2235)
8105	23.63 (600)	28.06 (713)	78 (1981)	88 (2235)
8106	27.75 (705)	32.19 (818)	92 (2337)	102 (2591)
8107	31.88 (810)	36.31 (922)	92 (2337)	102 (2591)
8108	36.00 (914)	40.44 (1027)	107 (2718)	117 (2972)
8109	40.13 (1019)	44.56 (1132)	107 (2718)	117 (2972)

*Dimensions in inches and (millimeters) and are approximate. Do not use for construction purposes.

†Dimension may vary depending on motor frame size.



HOUSTON SERVICE INDUSTRIES, INC.
7901 Hansen Rd • Houston, Texas 77061-3428
Phone: 800-725-2291 • 713-947-1623
Fax: 713-947-6409
E-mail: hsi@houserv.com
Web: www.hsiblowsers.com

Facility 0930104
Application No. 1270-2
E-16-081-01-03/05

REVISIONS			
REV	DESCRIPTION	DATE	DRAWN BY

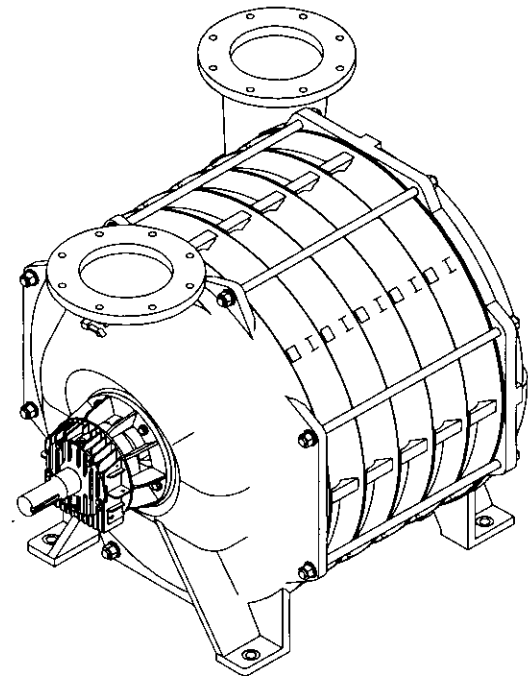
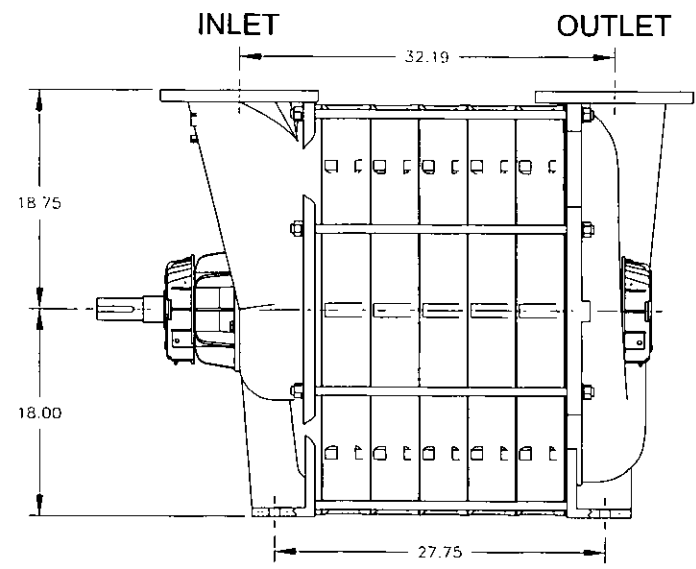
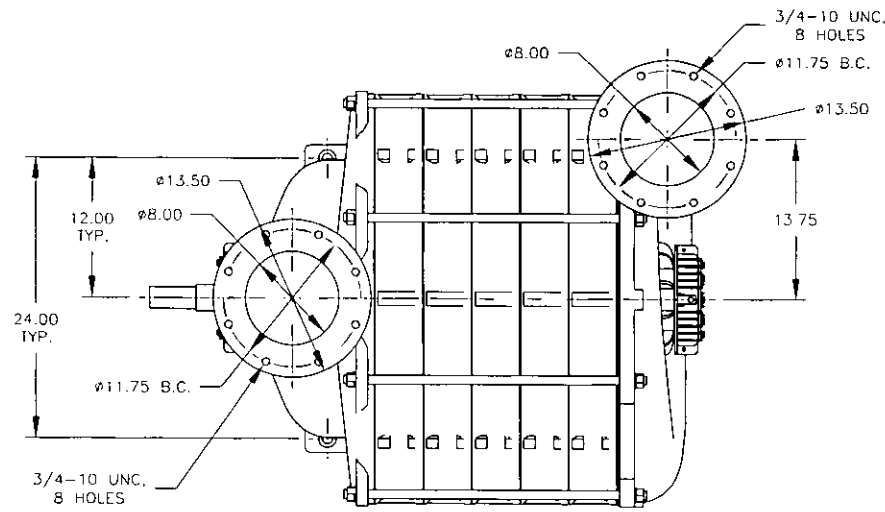

UNLESS OTHERWISE SPECIFIED: 3 PLACE DECIMALS ±.005 2 PLACE DECIMALS ±.010 ANGLES ±1° 125 ✓ MACHINED SURFACE FINISH DIMENSIONING AND TOLERANCES PER ANSI Y14.5M-1994 ALL DIMENSIONS IN INCHES REMOVE ALL BURRS AND SHARP EDGES		MATERIAL:	HOUSTON SERVICE INDUSTRIES 7901 HANSEN, HOUSTON, TX 77061	
DRAWN BY		AVG	21NOV02	
SIZE	REF.	PART NO./DWG. NO.		REV.
B		08106IDRV		0
SCALE: NONE		DO NOT SCALE DRAWING		SHEET: 1 OF 2

REVISIONS			
REV	DESCRIPTION	DATE	DRAWN BY

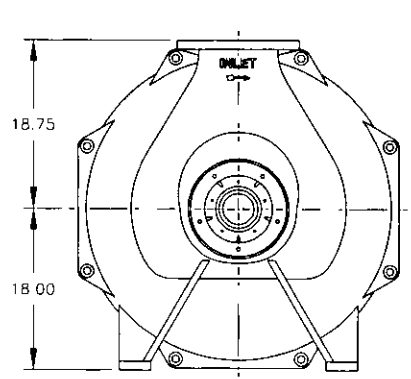

INLET POSITION 1
15081311

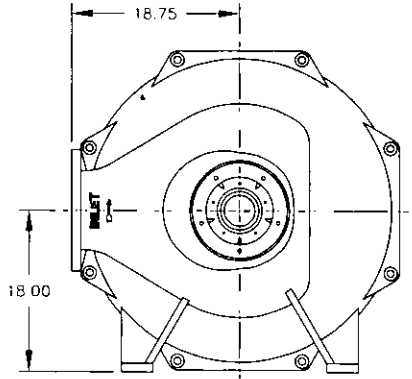

INLET POSITION 2
150813211

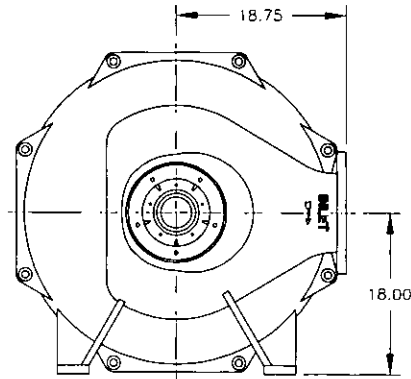

INLET POSITION 3
150813311

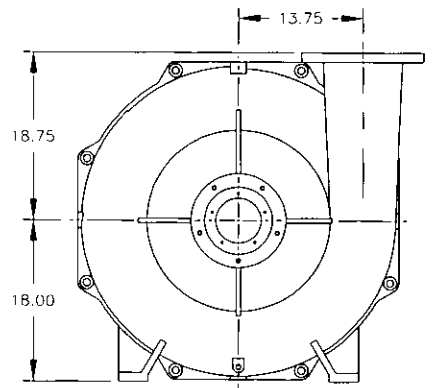

DISCHARGE POSITION 1
15081411

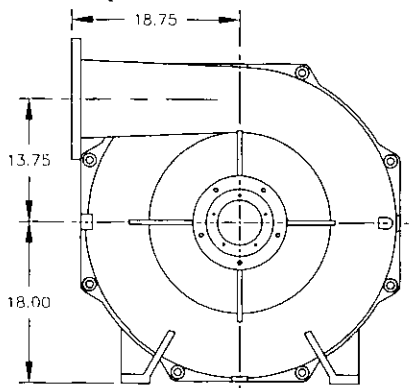

DISCHARGE POSITION 2
15081421

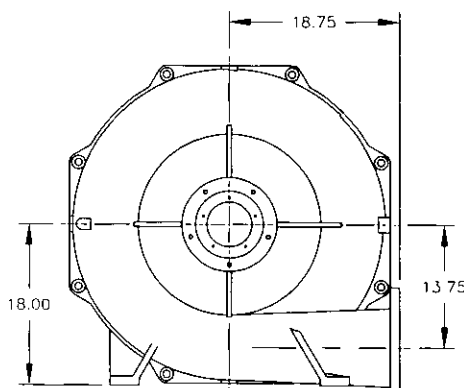

DISCHARGE POSITION 3
15081431

UNLESS OTHERWISE SPECIFIED:
 3 PLACE DECIMALS ±.005
 2 PLACE DECIMALS ±.010
 ANGLES ±1° 125/
 MACHINED SURFACE FINISH ✓
 DIMENSIONING AND TOLERANCES
 PER ANSI Y14.5M-1994
 ALL DIMENSIONS IN INCHES
 REMOVE ALL BURRS AND SHARP
 EDGES

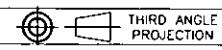

MATERIAL	
DRAWN BY	AVG 05/10/01
SIZE	REF.
B	

HSI HOUSTON SERVICE INDUSTRIES 7901 HANSEN, HOUSTON, TX 77061	
TITLE HSI 81 SERIES INLET & DISCHARGE POSITIONS	
SCALE: NONE	DO NOT SCALE DRAWING
SHEET: 2	OF 2

REVISIONS			
REV	DESCRIPTION	DATE	DRAWN BY

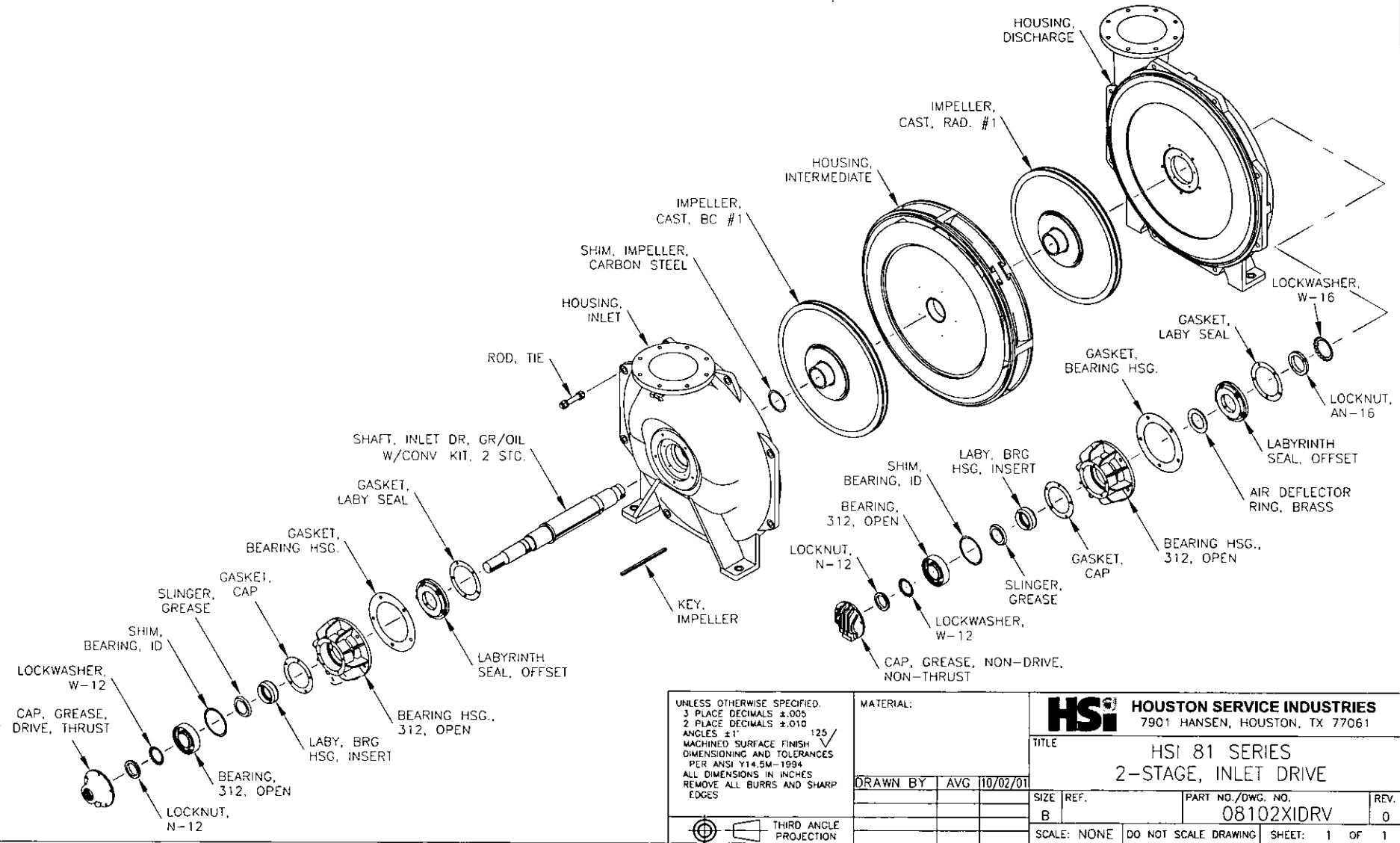

UNLESS OTHERWISE SPECIFIED:
 3 PLACE DECIMALS ±.005
 2 PLACE DECIMALS ±.010
 ANGLES ±1°
 MACHINED SURFACE FINISH 125
 DIMENSIONING AND TOLERANCES PER ANSI Y14.5M-1994
 ALL DIMENSIONS IN INCHES
 REMOVE ALL BURRS AND SHARP EDGES

MATERIAL:	
DRAWN BY	AVG 10/02/01
SIZE	REF.
B	

HSI HOUSTON SERVICE INDUSTRIES 7901 HANSEN, HOUSTON, TX 77061	
TITLE HSI 81 SERIES 2-STAGE, INLET DRIVE	
PART NO./DWG. NO. 08102XIDRV	REV. 0
SCALE: NONE DO NOT SCALE DRAWING SHEET: 1 OF 1	

HSI Series 81 & 82 Multistage Centrifugal Blower

Parts List

PART NUMBER	PART DESCRIPTION
1508173	Air Deflector Ring, Brass
15087830	Air Deflector, Baffle, Carbon Steel
15082832	Air Deflector, Baffle, Stainless Steel
15081201	Bearing Hsg.,312, Open
150812011	Bearing Hsg.,312, Open, Temp Probe
15081202	Bearing Hsg.,312, Sealed
BRG-312	Bearing, 312, Open
150812812	Cap, Bearing, Drive, Oil
150812842	Cap, Bearing, Non-Drive, Oil
150812851	Cap, Brg Hsg, w/ Pkg Gland, Thrust
150812821	Cap, Grease, Drive, Non-Thrust
150812811	Cap, Grease, Drive, Thrust
150812841	Cap, Grease, Non-Drive, Non-Thrust
150812831	Cap, Grease, Non-Drive, Thrust
150812853	Cover, Packing Gland
15081292	Gasket, Bearing Hsg.
15081291	Gasket, Cap
15081293	Gasket, Oil Reservoir
15081742	Gasket, Laby Seal
15081411	Housing, Discharge
150813111	Housing, Inlet
150818110	Housing, Intermediate
150815011	Impeller, Cast, BC #1
150815015	Impeller, Cast, BC #5
150815021	Impeller, Cast, Rad. #1
15081551	Key, Impeller
15081BRGKIT	Kit, Bearing, 081, 082
150812711	Laby, Brg Hsg Insert
15081721	Labyrinth Seal, Flat,
150817211	Labyrinth Seal, Flat, Purged
15081722	Labyrinth Seal, Offset
150817221	Labyrinth Seal, Offset, Purged
LKNUT-AN16	Locknut, AN-16
LKNUT-AN12	Locknut, N-12
LKWASHER-W12	Lockwasher, W-12
LKWASHER-W16	Lockwasher, W-16
150812862	Oil Reservoir, Non-Thrust
150812861	Oil Reservoir, Thrust
150812611	Oil Slinger, w/o Holes, Aluminum
15081046	Rod, Tie
15081111	Shaft, Inlet Dr, Gr/Oil w/ Conv. Kit, 1 Stg.
15081121	Shaft, Inlet Dr, Gr/Oil w/ Conv. Kit, 2 Stg.
15081131	Shaft, Inlet Dr, Gr/Oil w/ Conv. Kit, 3 Stg.
15081141	Shaft, Inlet Dr, Gr/Oil w/ Conv. Kit, 4 Stg.
15081151	Shaft, Inlet Dr, Gr/Oil w/ Conv. Kit, 5 Stg.
15081161	Shaft, Inlet Dr, Gr/Oil w/ Conv. Kit, 6 Stg.
15081171	Shaft, Inlet Dr, Gr/Oil w/ Conv. Kit, 7 Stg.
15081181	Shaft, Inlet Dr, Gr/Oil w/ Conv. Kit, 8 Stg.
15081191	Shaft, Inlet Dr, Gr/Oil w/ Conv. Kit, 9 Stg.
15081221	Shim, Bearing, ID
15081530	Shim, Impeller, Carbon Steel
15081531	Shim, Impeller, Stainless Steel
150812642	Slinger, Grease
15081241	Spacer, Brg/Oil Slinger
15081223	Wavy Spring Washer

FLARE Systems

Utility "Candle Stick" Flares

LFG Specialties manufactures a full range of utility "candle stick" type flares for landfill gas and wastewater gas applications. The flares are specifically designed for high-efficiency combustion of landfill gas, guaranteeing 98% destruction efficiency.

Features

- *Guaranteed to meet EPA emission standards for methane disposal*
- *Flame-Trol—advanced fully automated flare controller*
- *Energy saving pilot system*
- *Full range of standard sizes*
- *Quick delivery—eight weeks or less for most flares*
- *Full service and parts support—24 hour emergency service*

LFG Specialties will also custom design and manufacture flares, controllers and combustor systems to meet specific customer conditions and specifications.

Standard Equipment

Flare Stack—Sch 40, steel pipe with self supporting base and 150# flanged inlet.

Combuster Assembly—Burner tip with flame retainer and windshield, all 304 SS.

Igniter Assembly—304 SS pilot tip and nozzle, enclosed spark plug igniter, high temperature leads, 110/15,000 volt transformer in NEMA 4 enclosure, and chromel-alumel (type K) thermocouples in SS wells.

Peripheral Equipment—Flame arrester, temperature and flame monitoring and pilot gas controls including: pressure regulator, gauge, fail-safe solenoid valve and manual shut-off valve.

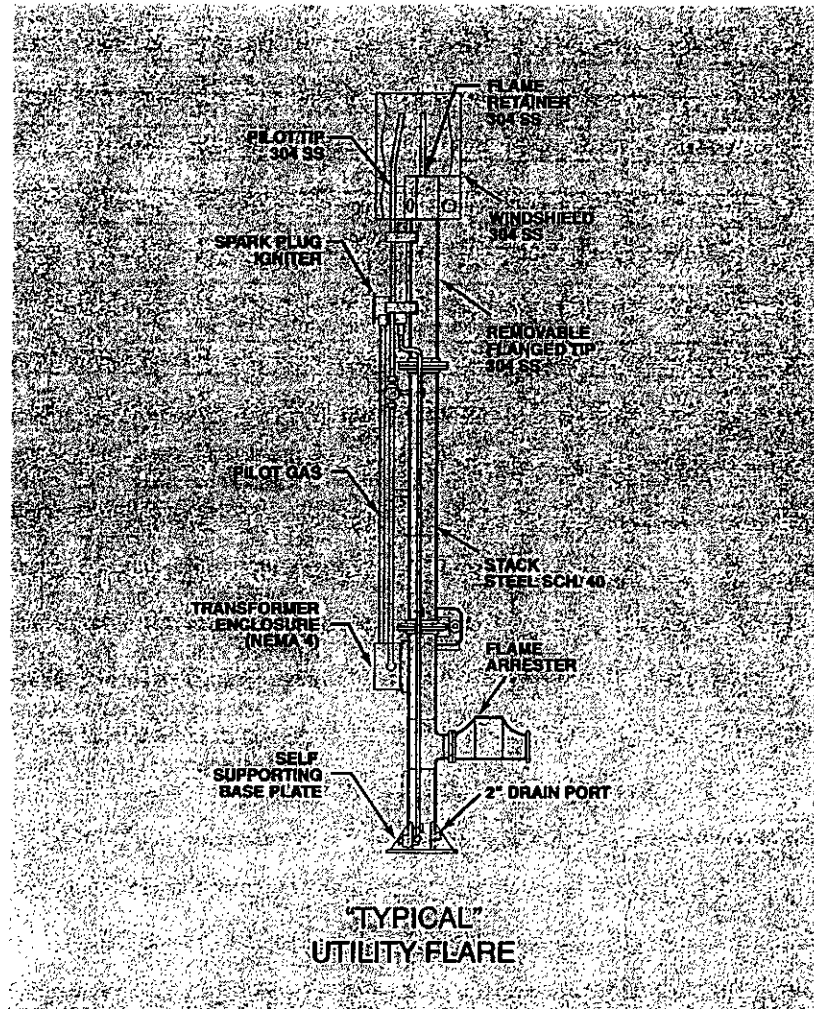

LFG Specialties, Inc.

FLARE Systems

Utility "Candle Stick" Flares
Con't.

New EU: 3,000scfm (odor control)					New EU: 6,000scfm flare				
Standard Utility Flare Specifications	CF41814	CF61914	CF82516	CF102518	CF1230110	CF1434112	CF1635114	CF1840116	CF2045118
Model									
Flow Rates (SCFM)	Turndown Ratio 10:1								
Range	35-350	79-790	135-1362	210-2131	300-3014	350-3578	470-4717	600-6013	744-7466
Design	260	590	1050	1620	2360	3210	4190	5300	6500
Tip ø In.	4"	6"	8"	10"	12"	14"	16"	18"	20"
Height Ft.	20'	21'	28'	28'	33'	38'	39'	45'	53'
Flame Arrester size (dia.)	4"	4"	6"	8"	10"	10"	12"	16"	18"

Minimum methane content - 30%

Note: Below 30% enrichment gas is required to maintain stable flame and 98% destruction efficiency.

Wind loads - Designed for 100 mph wind loading (per ANSI/ASCE 7-88)

Flame-Trol

LFG Specialities manufactures a full line of flare and system controllers. The Flame-Trol is a technically advanced fully automatic flare system controller specifically designed to obtain the maximum operating flexibility and efficiency out of a utility "candle stick" type flare. The controller has the following features:

- *Temperature controller to monitor and control set points at which operating functions will occur, including:*
 - pilot, on and off
 - blowers, on and off
 - activate automatic header valve
 - system safety shutdown.
- *Controller has constant LED temperature read-out*
- *Pilot timer, provides safety shutoff if flare fails to light*
- *Down timer, variable restart timer to allow for gas update rejuvenation*
- *Igniter timer, sets the spark duration for more reliable ignition and extending igniter system life*
- *Manual/Auto-Switch, allows operator to bypass automatic controls and operate the system manually.*

The Flame-Trol is installed in a NEMA 4 "outdoor" weather proof enclosure.

LFG Specialities is a full service manufacturer, offering standard, made to order, and special engineered flares, flare controllers and auxiliary equipment and systems. Along with standard installation, inspection and repair parts and service, LFG Specialities also offers a full range of contract rental equipment, and operation and maintenance agreements tailored to the customer's specific needs and requirements.

Appendix C
Permit Application 1270-2
Facility ID No. 0930104
Landfill Gas (Fuel) Analysis

Appendix C Landfill Gas (Fuel) Analysis

Okeechobee Landfill, Inc.
Okeechobee Landfill

Permit Application No.: 1270-2
Facility ID No.: 0930104

The fuel for the flare is provided by the municipal waste decomposition in the MSW landfill (EU-001) and varies due to the heterogeneous nature of the waste, moisture, time in place, and decomposition rate. The fuel's available heating value (Btu) is substantially provided by the methane. The table below presents the typical composition of a productive landfill gas.

Typical Landfill Gas Components	
Component	Percent by Volume
Methane	45–60
carbon dioxide	40–60
Nitrogen	2–5
Oxygen	0.1–1
ammonia	0.1–1
NMOCs (non-methane organic compounds) NMOCs most commonly found in landfills include acrylonitrile, benzene, 1,1-dichloroethane, 1,2-cis dichloroethylene, dichloromethane, carbonyl sulfide, ethyl-benzene, hexane, methyl ethyl ketone, tetrachloroethylene, toluene, trichloroethylene, vinyl chloride, and xylenes.	0.01–0.6
Sulfides (e.g., hydrogen sulfide, dimethyl sulfide, mercaptans)	0–1
hydrogen	0–0.2
carbon monoxide	0–0.2

Source: Tchobanoglous, Theisen, and Vigil 1993; EPA 1995

The following two table presents the typical fuel analysis that was used as a basis for the emission calculations of the flares for this facility. Additional information may be found in Appendix B – Support Calculations.

Standard Conditions, Constants, and Typical Values

Category	Value	Equivalent
Standard Temperature ^a	80 °F	520 °R
Universal Gas Constant:	0.7302	atm-ft ³ /lb-mol ^o R
Pressure ^a	1	atm
Methane Heating Value ^b	1,000	Btu/ft ³
LFG Methane Component ^c	50%	
LFG Typical Heating Value	500	Btu/ft ³
LFG Temperature ^c	100 °F	560 °R
LFG Moisture ^c	5%	
Methane Combustion Constant ^d	2.53	ft ³ air/ft ³ CH ₄

^aIndustrial STP (60°F, 30.00 in. Hg, 1 atm)

The following table provides the data used for sulfur content in the Landfill Gas. Values are from AP-42 except the Hydrogen Sulfide, which is based on site specific data provided by the Facility.

LFG Compound	CAS	MW (lb/lb-mol)	Conc (ppmv) ^a
Carbon Disulfide	75-15-0	76.13	0.58
Carbonyl Sulfide	483-85-1	60.07	0.40
Dimethyl Sulfide (methyl sulfide)	75-15-3	62.13	7.62
Ethyl Mercaptan (ethanethiol)	75-29-1	62.13	2.28
Hydrogen Sulfide	7783-26-4	34.08	5786.00
Methyl Mercaptan	74-93-1	48.11	2.40

Good Engineering Practice Stack Height Analysis (Rule 62-212.400(4)(d),F.A.C.,
and rule 62-212.500(4)(f),F.A.C.)

**Please refer to Section 3.4 of Section III – of the Air Quality
Impact Analysis**

Operation and Maintenance Plan

The O & M Plan for the landfill gas collection and treatment is comprised of several large binders, therefore it will not be submitted but maintained at the facility

Appendix A

General Description of the Municipal Solid Waste Landfill Process (For Informational Purposes Only)

Landfilling of municipal solid waste (MSW) has been a generally acceptable means of disposal for many years. MSW landfills (LFs) receive primarily household (42%) and/or commercial waste (11%), but also receive construction demolition wastes (29%), industrial processes wastes (2%), sewage sludge (4%), Contaminated soil (12%) and lesser amounts of incinerator ash, small quantity generator hazardous wastes, infectious wastes, asbestos-containing waste materials, and other wastes. Current practice is to spread the waste in layers, compacting and covering it with soil. The compacted layers compose the landfill building blocks called *cells*. The buried waste decomposes biologically and chemically to produce solid, liquid and gaseous products, typically significant volumes of various gases such as methane and carbon dioxide with smaller amounts of volatile organic compounds (VOCs). Other constituents of LF gas are usually present in trace amounts and are not of a concern with regard to an explosive hazard and can include hydrogen, ammonia, hydrogen sulfide, nitrogen, hydrogen chloride, and carbon monoxide.

MSW landfills are potential sources of emissions of gas mixtures generated from the natural decomposition of organic wastes and vapors from volatile compounds present in the wastes. The concerns associated with LF gas commonly involve odors, combustion/explosive hazards, and possible toxic effects. MSW LFs are different from many other emissions source categories (i.e., manufacturing facilities) because LFs will continue to generate LF gas emissions for many years after closure. Landfill operators must consider subsurface gas migration, gas collection, control and recovery systems, and ambient air quality impacts including odors. Studies of landfill gas emissions have been performed to support landfill permits, landfill closures, permitting and design of gas collection, control, and recovery systems as well as to assess potential impacts and site acceptability for alternate uses. The most important objective of landfill design is prevention of negative effects on human health and the environment and the prevention of adverse effects to groundwater and surface water.

Process Description

A cell is a constructed lined area where waste is placed. Liners used of low-permeability soil or a combination of soil and synthetic (i.e., high-density polyethylene) are often used beneath the landfill to contain liquid produced from waste decomposition. The thickness of the waste lift varies but can be generally described as approximately 10 feet. Usually a days refuse is covered as the end of each day with soil cover or an approved alternative daily cover such as temporary plastic sheets. When the final permitted elevations and grades of the waste are reached, the landfill is capped. The cap systems, similar to the cell liners, are constructed of a low-permeable soil or a synthetic liner. LFG continues to be generated but is contained by the capping system. A system of gas extraction wells and pipe headers are installed to collect the gas and prevent gas buildup, aid in the prevention of landfill gas odors, and possible landfill gas migration.

Landfill gas is generated at both active and inactive LFs. Natural biological processes occurring in LFs transform the waste's constituents, producing leachate and gas. Anaerobic decomposition of buried refuse produces relatively high concentrations of methane and carbon dioxide. Decomposition of waste can reach the anaerobic steady methanogenic phase in

around 2 to 4 years. Below are the 5 phases of landfill decomposition and the length of time for each.

- Initially, decomposition is aerobic until the oxygen supply is exhausted also characterized by the increase in carbon dioxide. The time and duration is difficult to identify for the various phases of waste decomposition and gas generation, which varies with landfill conditions such as waste composition, moisture content, temperature, weather, etc. This initial phase begins shortly after the placement of the refuse and can be expected to last on the order of between several hours and weeks.
- During phase 2, oxygen reserves are depleted and anaerobic conditions begin and can typically last for several months.
- Phase 3 is marked by the transformation of complex materials such as cellulose, fats, proteins, and carbohydrates into simple organic materials such as acetic acid. Phase 3 may last from several months to several years.
- During phase 4, the acids formed are consumed by anaerobic methanogenic bacteria and converted into methane and carbon dioxide.
- During the phase 5, most of the nutrients required to sustain the methanogenic bacterial population have been depleted, reducing the amount of methane generated. Both phases 4 and 5 can last for decades.

Heat Generated

The heating value of landfill gas is derived mostly from its methane content (note that the heating value of landfill gas is much lower than that of natural gas). This heating value makes disposal of LF gas practical and efficient by burning. It also can be recovered for use as a fuel for combustion engines or boilers for generation of electric power or cleaned up to pipeline quality for consumer use.

Figure 1 - provides an overview that illustrates the gamut of potential activities, emission sources, collection systems, recovery facilities, and control devices at MSW landfills.

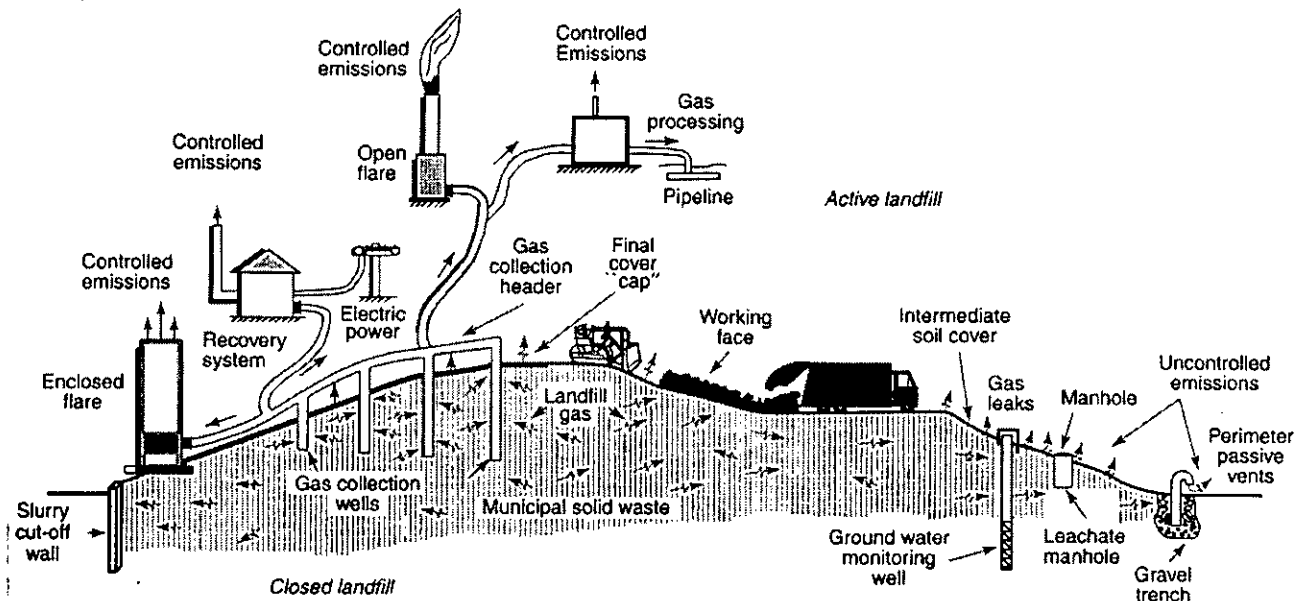

Figure 1. Municipal Solid Waste Landfill Gas Emissions.

**Emissions Calculations
Okeechobee (Berman Road) Landfill
Okeechobee, FI**

BASELINE ACTUAL EMISSIONS

EU NO.	Description	Average 24-month flow rate (scfm)	24-month period Hours of Operation	Units	Emissions										
					NO _x	CO	SO ₂ w/o BACT ^(c)	SO ₂ w/ BACT ^(c)	PM ₁₀	NMOC	VOC	HAP (Total)	HAP (Single)	H2S w/o BACT	H2S with BACT
003	Enclosed Flare Unit 1	2,237	16,902	lb/hr	3.66	12.2	131.6	Not relevant	1.0	0.4	0.1	0.6	0.5	0.07	Not relevant
				tpy	15.5	51.5	556.3		4.0	1.5	0.6	2.6	2.3	0.30	
005	Enclosed Flare Unit 2	2,246	17,168	lb/hr	3.67	12.25	132.07		0.96	0.36	0.14	0.62	0.54	0.07	
				tpy	15.8	52.6	566.9		4.1	1.6	0.6	2.6	2.3	0.30	
004	Open Flare (Backup)	2,240	847	lb/hr	4.57	24.87	131.89		1.06	0.37	0.15	0.61	0.54	0.08	
				tpy	1.0	5.3	27.9		0.2	0.1	0.0	0.1	0.1	0.02	
NA	Open Flare (Odor Control)	764	5,150	lb/hr	1.6	8.5	45.0		0.4	0.1	0.1	0.2	0.2	0.03	
				tpy	2.0	10.9	57.9		0.5	0.2	0.1	0.3	0.2	0.04	
CURRENT ACTUAL BASELINE EMISSIONS				lb/hr	13.5	57.9	440.7		3.4	1.3	0.5	2.1	1.9	0.3	
				tpy	34.3	120.4	1,209.0		8.9	3.4	1.4	5.7	5.0	0.7	

Emissions Calculations
Okeechobee (Berman Road) Landfill
Okeechobee, FI

PROVIDED FOR INFORMATIONAL PURPOSES ONLY

SUMMARY - PROPOSED POTENTIAL TO EMIT WITHOUT BACT [INTERIM OPERATING SCENARIO]

Control Device ID	Description	Max. Potential LFG Flow (scfm)	Max. Annual Potential Operation (hours)	Units	Emissions										
					NO _x	CO	SO ₂ w/o BACT ^(c)	SO ₂ w/ BACT ^(c)	PM ₁₀	NMOC	VOC	HAP (Total)	HAP (Single)	H ₂ S w/o BACT	H ₂ S with BACT
CD-01	Existing Enclosed Flare w/EVAP ^(a,b)	3,000	8760	lb/hr	5.4	18.0	176.2	Not relevant	1.4	0.5	0.19	0.8	0.7	0.09	Not relevant
				tpy	23.7	78.8	771.6		6.2	2.1	0.8	3.6	3.2	0.41	
CD-02	Existing Enclosed Flare w/EVAP	3,000	8760	lb/hr	5.4	18.0	176.2		1.4	0.5	0.2	0.8	0.7	0.09	
				tpy	23.7	78.8	771.6		6.2	2.1	0.8	3.6	3.2	0.41	
CD-03	Existing Utility Flare (backup)	3,300	8760	lb/hr	6.7	36.6	193.8		1.55	0.53	0.21	0.9	0.80	0.10	
				tpy	29.5	160.4	848.7		6.8	2.3	0.9	4.0	3.5	0.45	
CD-04	Existing Utility Flare (odor control)	3,300	8760	lb/hr	6.7	36.6	193.8		1.5	0.5	0.2	0.9	0.8	0.10	
				tpy	29.5	160.4	848.7		6.8	2.3	0.9	4.0	3.5	0.45	
CD-05	Proposed Utility Flare (odor control)	3,300	8760	lb/hr	6.7	36.6	193.8		1.5	0.5	0.2	0.9	0.8	0.10	
				tpy	29.5	160.4	848.7		6.8	2.3	0.9	4.0	3.5	0.45	
TOTAL Proposed PTE without BACT				lb/hr	31.0	145.9	933.7	7.5	2.6	1.1	4.4	3.9	0.5		
				tpy	135.8	639.0	4,089.4	32.7	11.3	4.5	19.2	16.9	2.2		

PROVIDED FOR INFORMATIONAL PURPOSES ONLY

Emissions Calculations
 Okeechobee (Berman Road) Landfill
 Okeechobee, FI

SUMMARY - PROPOSED POTENTIAL TO EMIT FOR TURBINE OPERATING CONDITIONS WITH BACT

Control Device ID	Description	Max. Potential LFG Flow (scfm)	Annual Potential Operation (hours)	units	Emissions										
					NO _x	CO	SO ₂ w/o BACT ^(c)	SO ₂ w/ BACT ^(c)	PM ₁₀	NMOC	VOC	HAP (Total)	HAP (Single)	H ₂ S w/o BACT	H ₂ S with BACT
CD-11	Turbine ^(a,b)	4,000	8760	lb/hr	31.07	31.3	234.9	16.2	2.2	0.6	0.3	1.1	1.0	0.12	0.01
				tpy	136	137	1,029	71	10	3	1	5	4	0.55	0.04
CD-12	Turbine ^(a,b)	4,000	8760	lb/hr	31.07	31.3	234.9	16.2	2.2	0.6	0.3	1.1	1.0	0.12	0.01
				tpy	136	137	1,029	71	10	3	1	5	4	0.55	0.04
CD-13	Turbine ^(a,b)	4,000	8760	lb/hr	31.07	31.3	234.9	16.2	2.2	0.6	0.3	1.1	1.0	0.12	0.01
				tpy	136	137	1,029	71	10	3	1	5	4	0.55	0.04
CD-14	Turbine ^(a,b)	4,000	8760	lb/hr	31.07	31.3	234.9	16.2	2.2	0.6	0.3	1.1	1.0	0.12	0.01
				tpy	136	137	1,029	71	10	3	1	5	4	0.55	0.04
CD-15	Turbine ^(a,b)	4,000	8760	lb/hr	31.07	31.3	234.9	16.2	2.2	0.6	0.3	1.1	1.0	0.12	0.01
				tpy	136	137	1,029	71	10	3	1	5	4	0.55	0.04
CD-16	Turbine ^(a,b)	4,000	8760	lb/hr	31.07	31.3	234.9	16.2	2.2	0.6	0.3	1.1	1.0	0.12	0.01
				tpy	136	137	1,029	71	10	3	1	5	4	0.55	0.04
CD-17	Turbine ^(a,b)	4,000	8760	lb/hr	31.07	31.3	234.9	16.2	2.2	0.6	0.3	1.1	1.0	0.12	0.01
				tpy	136	137	1,029	71	10	3	1	5	4	0.55	0.04
CD-03	Open Unenclosed Flare	3,300	8760	lb/hr	6.7	36.6	193.8	13.36	1.5	0.5	0.2	0.9	0.8	0.10	0.01
				tpy	29	160	849	59	7	2	1	4	4	0.45	0.03
CD-04	Open Unenclosed Flare	1,100	8760	lb/hr	2.2	12.2	64.6	4.5	0.5	0.2	0.1	0.3	0.3	0.03	0.002
				tpy	10	53	283	20	2	1	0	1	1	0.15	0.01
TOTAL Proposed PTE with BACT		32,400		lb/hr	226.5	267.8	1,902.6	131.3	17.6	5.3	2.1	8.9	7.9	1.1	0.1
tpy	991.9			1,173.0	8,333.0	574.8	76.8	23.0	9.0	39.0	34.4	4.5	0.3		

**Emissions Calculations
Okeechobee (Berman Road) Landfill
Okeechobee, FL**

SUMMARY - ALTERNATIVE OPERATING SCENARIO - POTENTIAL TO EMIT FOR FLARE OPERATING CONDITIONS WITH BACT

Control Device ID	Description	Max. Potential LFG Flow (scfm)	Max. Annual Potential Operation (hours)	Units	Emissions										
					NO _x	CO	SO ₂ w/o BACT ^(c)	SO ₂ w/ BACT	PM ₁₀	NMOC	VOC	HAP (Total)	HAP (Single)	H2S w/o BACT	H2S with BACT
CD-01	Existing Enclosed Flare w/EVAP ^(a,b)	3,000	8760	lb/hr	5.4	18.0	176.2	12.1	1.4	0.5	0.2	0.8	0.7	0.09	0.01
				tpy	23.7	78.8	772	53.2	6.2	2.1	0.8	3.6	3.2	0.41	0.03
CD-02	Existing Enclosed Flare w/EVAP	3,000	8760	lb/hr	5.4	18.0	176.2	12.1	1.4	0.5	0.2	0.8	0.7	0.09	0.01
				tpy	23.7	78.8	772	53.2	6.2	2.1	0.8	3.6	3.2	0.41	0.03
CD-03	Open Unenclosed Flare (Backup)	3,300	8760	lb/hr	6.7	36.6	193.8	13.4	1.5	0.5	0.2	0.9	0.8	0.10	0.01
				tpy	29.5	160.4	848.7	58.5	6.8	2.3	0.9	4.0	3.5	0.45	0.03
CD-04	Proposed Utility Flare (odor control)	3,300	8760	lb/hr	6.7	36.6	193.8	13.4	1.5	0.5	0.2	0.9	0.8	0.10	0.01
				tpy	29.5	160.4	849	58.5	6.8	2.3	0.9	4.0	3.5	0.45	0.03
CD-05	Proposed Utility Flare	3,300	8760	lb/hr	6.7	36.6	193.8	13.4	1.5	0.5	0.2	0.9	0.8	0.10	0.01
				tpy	29.5	160.4	849	58.5	6.8	2.3	0.9	4.0	3.5	0.45	0.03
CD-06	Proposed Utility Flare	3,300	8760	lb/hr	6.7	36.6	193.8	13.4	1.5	0.5	0.2	0.9	0.8	0.10	0.01
				tpy	29.5	160.4	849	58.5	6.8	2.3	0.9	4.0	3.5	0.45	0.03
CD-07	Proposed Utility Flare	3,300	8760	lb/hr	6.7	36.6	193.8	13.4	1.5	0.5	0.2	0.9	0.8	0.10	0.01
				tpy	29.5	160.4	849	58.5	6.8	2.3	0.9	4.0	3.5	0.45	0.03
CD-08	Proposed Utility Flare	3,300	8760	lb/hr	6.7	36.6	193.8	13.4	1.5	0.5	0.2	0.9	0.8	0.10	0.01
				tpy	29.5	160.4	848.7	58.5	6.8	2.3	0.9	4.0	3.5	0.45	0.03
CD-09	Proposed Utility Flare	3,300	8760	lb/hr	6.7	36.6	193.8	13.4	1.5	0.5	0.2	0.9	0.8	0.10	0.01
				tpy	29.5	160.4	849	58.5	6.8	2.3	0.9	4.0	3.5	0.45	0.03
CD-10	Proposed Utility Flare	3,300	8760	lb/hr	6.7	36.6	193.8	13.4	1.5	0.5	0.2	0.9	0.8	0.10	0.01
				tpy	29.5	160.4	848.7	58.5	6.8	2.3	0.9	4.0	3.5	0.45	0.03
Total Proposed PTE Flaring with BACT		32,400	8,760	lb/hr	64.7	329.1	1,902.6	131.3	15.3	5.3	2.1	8.9	7.9	1.1	0.1
				tpy	283.2	1,441.2	8,333.0	574.8	66.6	23.0	9.0	39.0	34.4	4.5	0.3

Emissions Calculations
Okeechobee (Berman Road) Landfill
Okeechobee, FL

MAXIMUM POTENTIAL-TO-EMIT TO BASELINE ACTUAL NET INCREASE (highest rate used per pollutant)															
Control Device ID	Description	Max. Potential LFG Flow (scfm)	Max. Annual Potential Operation (hours)	Units	Emissions										
					NO _x	CO	SO ₂ w/o BACT	SO ₂ w/ BACT	PM ₁₀	NMOC	VOC	HAP (Total)	HAP (Single)	H2S w/o BACT	H2S with BACT
					Varies	Control Device with For each pollutant,	32,400	8760	tpy	957.6	1,320.8	7,124.0	(634.2)	67.9	19.6
Significant Emission Rates [62-210.200(264) F.A.C.]				tpy	40	100	40	40	15	50	40	25	10	10	10
Source for Highest Pollutant Rate					Turbines	Flares	Both	Both	Turbines	Both	Both	Both	Both	Both	Both

Solar Turbines

A Caterpillar Company

PREDICTED ENGINE PERFORMANCE

Customer Waste Management		Model MARS 100-15000
Job ID		Package Type GSC
Run By Donald C Lyons	Date Run 24-Oct-06	Match 59F MATCH
Engine Performance Code REV. 3.40	Engine Performance Code REV. 3.0	Fuel System GAS
		Fuel Type CHOICE NATURAL GAS

DATA FOR NOMINAL PERFORMANCE

Elevation	feet	50		
Inlet Loss	in H2O	3.5		
Exhaust Loss	in H2O	3.5		
		1	2	3
Engine Inlet Temperature	deg F	59.0	59.0	59.0
Relative Humidity	%	60.0	60.0	60.0
Specified Load*	kW	FULL	75.0%	50.0%
Net Output Power*	kW	10924	8193	5462
Fuel Flow	mmBtu/hr	114.28	90.11	68.99
Heat Rate*	Btu/kW-hr	10461	10999	12630
Therm Eff*	%	32.619	31.023	27.015
Engine Exhaust Flow	lbm/hr	342595	306920	263057
Exhaust Temperature	deg F	894	818	778

Fuel Gas Composition (Volume Percent)	Methane (CH4)	50.00
	Carbon Dioxide (CO2)	50.00
	Sulfur Dioxide (SO2)	0.0001

Fuel Gas Properties	LHV (Btu/Scf)	454.7	Specific Gravity	1.0366	Wobbe Index at 60F	446.6
---------------------	---------------	-------	------------------	--------	--------------------	-------

*Electric power measured at the generator terminals.

Notes	Florida
-------	---------

Emissions Calculations
Okeechobee (Berman Road) Landfill
Okeechobee, FL

EMISSIONS DATA PROVIDED BY MANUFACTURER VIA EMAIL

-----Original Message-----

From: Chris D. Lyons [mailto:Lyons_Chris_D@solarturbines.com]

Sent: Tuesday, October 24, 2006 11:52 AM

To: Unger, Dave (Renewable Energy)

Subject: Mars 100 emissions

Dave,

I need to get an official engineering response to your request. The landfill in Paris had a different fuel composition than your site in Florida. I am assuming 50% methane, 50% carbon dioxide.

I have attached the expected performance and below are what I believe will be the emissions.

Full	load			
NOx	=	60 ppmv @15%oxygen	=	31.067 lb/hr
CO	=	60 ppmv @15%oxygen	=	31.517 lb/hr
	75% Load			
NOx	=	42 ppmv @15%oxygen	=	16.782 lb/hr
CO	=	80 ppmv @15%oxygen	=	19.457 lb/hr
	50% Load			
NOx	=	30 ppmv @15%oxygen	=	10.278 lb/hr
CO	=	150 ppmv @15%oxygen	=	31.279 lb/hr

Let me know if you will need any other data. It will take a few days to receive an official response back from engineering.

Regards,
Chris Lyons
Solar Turbines
Phone: 1-858-694-6586

**Emissions Calculations
 Okeechobee (Berman Road) Landfill
 Okeechobee, FI**

Parameter	Value	Units	Reference
Exhaust Temp	894	F	Mars 100-15000, 100% Load
Exhaust Temp	818	F	Mars 100-15000, 75% Load
Exhaust Temp	778	F	Mars 100-15000, 50% Load
Stack Height	50	ft	Parameter Modelling determined
Stack Side	87.5	in	Solar Turbines
Stack Side	90.5625	in	Solar Turbines
Stack Interior Diameter	100	in	Calculated
PM10 Rate	0.023	lb/MMBtu	AP-42, Table 3.1-2b
Turbine Inlet	4000	scfm	Solar Turbines
Lanfill gas HHV	400	Btu/scf	AP-42, Table 3.1-2b
PM10 Rate	2.2	lb/hr	Calculated

Calculation of Flow Rate

		100%	75%	50%
Total Mass Out	lb/hr	342,595	306,920	263,057
Solar Turbines Inc. Mass out	lb/hr	354239		
Solar Turbines Inc. Exhaust Flow	acfm	200336		
Total Flow out	acfm	193,751	178,678	148,769
Total Flow out	ft/s	58.68	52.57	45.06

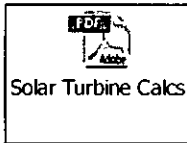

**Emissions Calculations
Okeechobee (Berman Road) Landfill
Okeechobee, FL**

Criteria Pollutant Emissions - Turbines

Operation Period 8,760 hr
LFG inlet flow, standard 4,000 scfm
Heat Input 90 MMBtu/hr
Standard Temperature^a 60 °F
520 °R

SO₂ Emission Rate

SO₂ concentration in exhaust gas 400.05 ppmv
SO₂ emission rate 16.20 lb/hr 71.0 tpy

LFG Compound	CAS	MW (lb/lb-mol)	Conc (ppmv) ^a	Control Eff ^{a,b}	Individual Compound Contribution to SO ₂		
					No. of S Atoms	S Conc (ppmv)	SO ₂ Emiss (lb/hr)
Carbon Disulfide	75-15-0	76.13	0.58	100.0%	2	1.17	0.05
Carbonyl Sulfide	463-58-1	60.07	0.49	100.0%	1	0.49	0.02
Dimethyl Sulfide (methyl sulfide)	75-18-3	62.13	7.82	100.0%	1	7.82	0.32
Ethyl Mercaptan (ethanethiol)	75-08-1	62.13	2.28	100.0%	1	2.28	0.09
Hydrogen Sulfide	7783-06-4	34.08	385.80	100.0%	1	385.8	15.62
Methyl Mercaptan	74-93-1	48.11	2.49	100%	1	2.49	0.10
Total Contribution to SO ₂ :						400.05	16.20

NMOC Emission Rate

NMOC conc inlet gas^a 595 ppmv
MW hexane 86.18 lb/lb-mol
destruction efficiency 98%
mass NMOC inlet gas 32.4 lb/hr
NMOC emission rate 0.65 lb/hr 2.84 tpy

VOC Emission Rate

NMOC conc inlet gas^a 595 ppmv
VOC fraction of NMOC^a 39%
VOC concentration in inlet gas 232 ppmv
MW hexane 86.18 lb/lb-mol
mass VOC inlet gas 12.6 lb/hr
destruction efficiency 98%
VOC emission rate 0.25 lb/hr 1.11 tpy

^aU.S. E.P.A., *Compilation of Air Pollutant Emission Factors, Volume I. Stationary Point and Area Sources ("AP-42"), 5th Ed.*, November 1998.

^bAP-42 gives ranges for control efficiencies.

LFG inlet flow
 Proposed LFG Turbines

LFG Compound	HAP	CAS	MW (lb/lb-mol)	Compound Conc & Mass in Inlet Gas		Control Eff ^{a, d}	turbine Exhaust	
				(ppmv) ^b	(lb/hr)		(lb/hr)*	(tpy)*
1,1,1 - Trichloroethane (methyl chloroform)	x	71-55-6	133.41	0.48	4.05E-02	98.0%	8.10E-04	3.55E-03
1,1,2,2 - Tetrachloroethane	x	79-34-5	167.85	1.11	1.18E-01	98.0%	2.36E-03	1.03E-02
1,1,2 - Trichloroethane (1,1,2 TCA)	x	79-00-5	133.41	0.10	8.43E-03	98.0%	1.69E-04	7.39E-04
1,1 - Dichloroethane (ethylidene dichloride)	x	75-34-3	98.96	2.35	1.47E-01	98.0%	2.94E-03	1.29E-02
1,1 - Dichloroethene (vinylidene chloride)	x	75-35-4	96.94	0.20	1.23E-02	98.0%	2.46E-04	1.08E-03
1,2 - Dichloroethane (ethylene dichloride)	x	107-06-2	98.96	0.41	2.55E-02	98.0%	5.09E-04	2.23E-03
1,2 - Dichloropropane (propylene dichloride)	x	78-87-5	112.99	0.18	1.29E-02	98.0%	2.57E-04	1.13E-03
2-Propanol (isopropyl alcohol)	--	67-63-0	60.11	50.1	1.90E+00	98.0%	3.81E-02	1.67E-01
Acetone (2-propanone)	--	67-64-1	58.08	7.01	2.57E-01	98.0%	5.15E-03	2.25E-02
Acrylonitrile (Propenenitrile)	x	107-13-1	53.06	6.33	2.12E-01	98.0%	4.25E-03	1.86E-02
Benzene	x	71-43-2	78.12	1.91	9.43E-02	98.0%	1.89E-03	8.26E-03
Bromodichloromethane	--	75-27-4	163.83	3.13	3.24E-01	98.0%	6.48E-03	2.84E-02
Butane	--	106-97-8	58.12	5.03	1.85E-01	98.0%	3.70E-03	1.62E-02
Carbon Disulfide	x	75-15-0	76.14	0.58	2.81E-02	98.0%	5.61E-04	2.46E-03
Carbon Tetrachloride	x	56-23-5	153.84	0.004	3.89E-04	98.0%	7.78E-06	3.41E-05
Carbonyl Sulfide	x	463-58-1	60.07	0.49	1.86E-02	98.0%	3.72E-04	1.63E-03
Chlorobenzene (monochlorobenzene)	x	108-90-7	112.56	0.25	1.81E-02	98.0%	3.61E-04	1.58E-03
Chlorodifluoromethane (CFC-22, freon-22)	--	75-45-6	86.47	1.30	7.11E-02	98.0%	1.42E-03	6.22E-03
Chloroethane (ethyl chloride)	x	75-00-3	64.52	1.25	5.10E-02	98.0%	1.02E-03	4.47E-03
Chloroform (trichloromethane)	x	67-66-3	119.38	0.03	2.26E-03	98.0%	4.53E-05	1.98E-04
Chloromethane (methyl chloride)	x	74-87-3	50.49	1.21	3.86E-02	98.0%	7.72E-04	3.38E-03
1,4 Dichlorobenzene (p-dichlorobenzene)	x	106-46-7	147	0.21	1.98E-02	98.0%	3.96E-04	1.73E-03
Dichlorodifluoromethane (CFC-12, freon-12)	--	75-71-8	120.91	15.7	1.20E+00	98.0%	2.40E-02	1.05E-01
Dichlorofluoromethane (freon-21)	--	75-43-4	102.92	2.62	1.70E-01	98.0%	3.41E-03	1.49E-02
Dichloromethane (methylene chloride)	x	75-09-2	84.93	14.3	7.68E-01	98.0%	1.54E-02	6.72E-02
Dimethyl Sulfide (methyl sulfide)	--	75-18-3	62.13	7.82	3.07E-01	98.0%	6.14E-03	2.69E-02
Ethane	--	74-84-0	30.07	889	1.69E+01	98.0%	3.38E-01	1.48E+00
Ethanol (ethyl alcohol)	--	64-17-5	46.08	27.2	7.92E-01	98.0%	1.58E-02	6.94E-02
Ethylbenzene	x	100-41-4	106.17	4.61	3.09E-01	98.0%	6.19E-03	2.71E-02
Ethyl Mercaptan (ethanethiol)	--	75-08-1	62.13	1.25	4.91E-02	98.0%	9.82E-04	4.30E-03
Ethylene dibromide (1,2 dibromoethane)	x	106-93-4	187.88	0.001	1.19E-04	98.0%	2.38E-06	1.04E-05
Fluorotrichloromethane (CFC-11, freon-11)	--	75-69-4	137.37	0.76	6.60E-02	98.0%	1.32E-03	5.78E-03
Hexane	x	110-54-3	86.18	6.57	3.58E-01	98.0%	7.16E-03	3.14E-02
Hydrogen Sulfide ^e	--	7783-06-4	34.08	385.8	8.31E+00	99.9%	8.31E-03	3.64E-02
Mercury (total)	x	7439-97-6	200.61	2.92E-4	3.70E-05	0.0%	3.70E-05	1.62E-04
Methyl Ethyl Ketone (2-butanone)	--	78-93-3	72.11	7.09	3.23E-01	98.0%	6.46E-03	2.83E-02
Methyl Isobutyl Ketone (hexone)	x	108-10-1	100.16	1.87	1.18E-01	98.0%	2.37E-03	1.04E-02
Methyl Mercaptan	--	74-93-1	48.11	2.49	7.57E-02	98.0%	1.51E-03	6.63E-03
Pentane	--	109-66-0	72.15	3.29	1.50E-01	98.0%	3.00E-03	1.31E-02
ethene)	x	127-18-4	165.83	3.73	3.91E-01	98.0%	7.82E-03	3.42E-02
Propane	--	74-98-6	44.1	11.1	3.09E-01	98.0%	6.19E-03	2.71E-02
Toluene (methylbenzene)	x	108-88-3	92.14	39.3	2.29E+00	98.0%	4.58E-02	2.00E-01
Trichloroethylene (trichloroethene)	x	79-01-6	131.38	2.82	2.34E-01	98.0%	4.68E-03	2.05E-02
dichloroethylene)	--	156-60-5	96.94	2.84	1.74E-01	98.0%	3.48E-03	1.52E-02
Vinyl Chloride (chloroethylene, VCM)	x	75-01-4	62.50	7.34	2.90E-01	98.0%	5.80E-03	2.54E-02
Xylenes (m, o, p)	x	1330-20-7	106.17	12.1	8.12E-01	98.0%	1.62E-02	7.11E-02
Hydrogen Chloride ^e	x	7647-01-0	36.50	42.0	9.69E-01	0.0%	9.69E-01	4.24E+00
Total HAP							1.10	4.8
Maximum Single HAP							0.97	4.24
Hydrogen Sulfide							0.01	0.04

^aU.S. E.P.A., *Compilation of Air Pollutant Emission Factors, Volume I. Stationary Point and Area Sources ("AP-42"), 5th Ed.*

^bAP-42 gives ranges for control efficiencies.

^cProduct of combustion

^dBecause HCl is a production of combustion, a default outlet concentration is listed; AP-42, Section 2.4.4.

^eControl Efficiency based on various references including; Canadian Centre for Occupational Health and Safety; CCOHS Chemical Name hydrogen Sulfide; October 3, 2005

EU003 3,000-scfm enclosed flare w/evap

Standard Conditions, Constants, and Typical Values

Category	Value	Equivalent
Standard Temperature ^a	60 °F	520 °R
Universal Gas Constant	0.7302 atm-ft ³ /lb-mol°R	
Pressure ^a	1 atm	
Methane Heating Value ^b	1,000 Btu/ft ³	
LFG Methane Component ^c	50%	
LFG Typical Heating Value	500 Btu/ft ³	
LFG Temperature ^c	100 °F	560 °R
LFG Moisture ^c	8%	
Methane Combustion Constant ^d	9.53 ft ³ air/ft ³ CH ₄	

^aIndustrial STP (60°F, 30.00 in. Hg, 1 atm)

^bTypical

^cAssumed

^dProfessional Engineering Registration Program , 23-9.

Fuel & Equipment - Enclosed Flare

Flare Information	Value	Equivalent
Operation Period ^a	8,760 hr	
LFG inlet flow, standard ^b	3,000 scfm	
LFG Inlet Flow, dry standard	2,760 dscfm	
Heat Input	90 MMBtu/hr	
Design Flare Operating Temperature ^c	1,400 °F	1,860 °R
Excess Air for Combustion ^c	230%	
Flare Tip Flow, standard	50,174 scfm	
Flare Tip Flow, actual	179,467 acfm	
Flare Tip Diameter ^b	10.0 ft	
Flare Tip Exhaust Velocity	2,285 ft/min	38.1 ft/s
Flare Tip Height, above local grade ^b	45 ft	

Criteria Pollutant Emissions - Enclosed Flare

**Emissions Calculations
 Okeechobee (Berman Road) Landfill
 Okeechobee, FL**

EU003 3,000-scfm enclosed flare w/evap

Operation Period

8,760 hr

LFG inlet flow, standard

3,000 scfm

Heat Input

90 MMBtu/hr

SO₂ Emission Rate without BACT							
SO ₂ concentration in exhaust gas		5800.25 ppmv					
SO ₂ emission rate		176.16 lb/hr		771.6 tpy			
LFG Compound	CAS	MW (lb/lb-mol)	Conc (ppmv) ^a	Control Eff ^{a,b}	Individual Compound Contribution to SO ₂		
					No. of S Atoms	S Conc (ppmv)	SO ₂ Emiss (lb/hr)
Carbon Disulfide	75-15-0	76.13	0.58	100.0%	2	1.17	0.04
Carbonyl Sulfide	463-58-1	60.07	0.49	100.0%	1	0.49	0.01
Dimethyl Sulfide (methyl sulfide)	75-18-3	62.13	7.82	100.0%	1	7.82	0.24
Ethyl Mercaptan (ethanethiol)	75-08-1	62.13	2.28	100.0%	1	2.28	0.07
Hydrogen Sulfide	7783-06-4	34.08	5786.00	100.0%	1	5786.0	175.72
Methyl Mercaptan	74-93-1	48.11	2.49	100.0%	1	2.49	0.08

Total Contribution to SO₂ : 5800.25 176.16

SO₂ Emission Rate with BACT							
Sulfur concentration in exhaust gas		400.05 ppmv					
SO ₂ emission rate		12.15 lb/hr uncontrolled		53.2 tpy			
LFG Compound	CAS	MW (lb/lb-mol)	Conc (ppmv) ^a	Control Eff ^{a,b}	No. of S Atoms	S Conc (ppmv)	SO ₂ Emiss (lb/hr)
Carbon Disulfide	75-15-0	76.13	0.58	100.0%	2	1.17	0.04
Carbonyl Sulfide	463-58-1	60.07	0.49	100.0%	1	0.49	0.01
Dimethyl Sulfide (methyl sulfide)	75-18-3	62.13	7.82	100.0%	1	7.82	0.24
Ethyl Mercaptan (ethanethiol)	75-08-1	62.13	2.28	100.0%	1	2.28	0.07
Hydrogen Sulfide	7783-06-4	34.08	385.80	100.0%	1	385.8	11.72
Methyl Mercaptan	74-93-1	48.11	2.49	100.0%	1	2.49	0.08

Total Contribution to SO₂ : 400.05 12.15

PM₁₀ Emission Rate			
PM emission factor ^a		17 lb/MM dscf CH ₄	
PM emission rate	1.41 lb/hr		6.2 tpy
NO₂ Emission Rate			
NO ₂ emission factor ^b		0.06 lb/MMBtu	
NO ₂ emission rate	5.4 lb/hr		23.7 tpy
CO Emission Rate			
CO emission factor ^b		0.20 lb/MMBtu	
CO emission rate	18.0 lb/hr		79 tpy
NMOC Emission Rate			
NMOC conc inlet gas ^a		595 ppmv	
MW hexane		86.18 lb/lb-mol	
destruction efficiency		98%	
mass NMOC inlet gas		24.3 lb/hr	
NMOC emission rate	0.49 lb/hr		2.13 tpy
VOC Emission Rate			
NMOC conc inlet gas ^a		595 ppmv	
VOC fraction of NMOC ^a		39%	
VOC concentration in inlet gas		232 ppmv	
MW hexane		86.18 lb/lb-mol	
mass VOC inlet gas		9.5 lb/hr	
destruction efficiency		98%	
VOC emission rate	0.19 lb/hr		0.83 tpy

^aEPA 1998. "Compilation of Air Pollutant Emission Factors, Volume I. Stationary Point and Area Sources" (AP-42), 5th Ed., November

^bAP-42 gives ranges for control efficiencies.

LFG inlet flow
EU003 3,000-scfm enclosed flare w/evap

Application 1270-2
3,000 scfm

Okeechobee (Berman Road) Landfill
Okeechobee, FI

LFG Compound	HAP	VOC	CAS	MW (lb/lb-mol)	Compound Conc & Mass in Inlet Gas		Control Eff ^{a,o}	Flare Exhaust	
					(ppmv) ^d	(lb/hr)		(lb/hr)*	(tpy)*
1,1,1 - Trichloroethane (methyl chloroform)	x	--	71-55-6	133.41	0.48	3.04E-02	98.0%	6.07E-04	2.66E-03
1,1,2,2 - Tetrachloroethane	x	x	79-34-5	167.85	1.11	8.83E-02	98.0%	1.77E-03	7.74E-03
1,1,2 - Trichloroethane (1,1,2 TCA)	x	x	79-00-5	133.41	0.10	6.32E-03	98.0%	1.26E-04	5.54E-04
1,1 - Dichloroethane (ethylidene dichloride)	x	x	75-34-3	98.96	2.35	1.10E-01	98.0%	2.20E-03	9.66E-03
1,1 - Dichloroethene (vinylidene chloride)	x	x	75-35-4	96.94	0.20	9.24E-03	98.0%	1.85E-04	8.09E-04
1,2 - Dichloroethane (ethylene dichloride)	x	x	107-06-2	98.96	0.41	1.91E-02	98.0%	3.82E-04	1.67E-03
1,2 - Dichloropropane (propylene dichloride)	x	x	78-87-5	112.99	0.18	9.64E-03	98.0%	1.93E-04	8.45E-04
2-Propanol (isopropyl alcohol)	--	x	67-63-0	60.11	50.1	1.43E+00	98.0%	2.86E-02	1.25E-01
Acetone (2-propanone)	--	--	67-64-1	58.08	7.01	1.93E-01	98.0%	3.86E-03	1.69E-02
Acrylonitrile (Propenenitrile)	x	x	107-13-1	53.06	6.33	1.59E-01	98.0%	3.18E-03	1.39E-02
Benzene	x	x	71-43-2	78.12	1.91	7.07E-02	98.0%	1.41E-03	6.20E-03
Bromodichloromethane	--	x	75-27-4	163.83	3.13	2.43E-01	98.0%	4.86E-03	2.13E-02
Butane	--	x	106-97-8	58.12	5.03	1.39E-01	98.0%	2.77E-03	1.21E-02
Carbon Disulfide	x	x	75-15-0	76.14	0.58	2.10E-02	98.0%	4.21E-04	1.84E-03
Carbon Tetrachloride	x	x	56-23-5	153.84	0.004	2.92E-04	98.0%	5.83E-06	2.56E-05
Carbonyl Sulfide	x	x	463-58-1	60.07	0.49	1.40E-02	98.0%	2.79E-04	1.22E-03
Chlorobenzene (monochlorobenzene)	x	x	108-90-7	112.56	0.25	1.36E-02	98.0%	2.71E-04	1.19E-03
Chlorodifluoromethane (CFC-22, freon-22)	--	--	75-45-6	86.47	1.30	5.33E-02	98.0%	1.07E-03	4.67E-03
Chloroethane (ethyl chloride)	x	x	75-00-3	64.52	1.25	3.82E-02	98.0%	7.65E-04	3.35E-03
Chloroform (trichloromethane)	x	x	67-66-3	119.38	0.03	1.70E-03	98.0%	3.40E-05	1.49E-04
Chloromethane (methyl chloride)	x	x	74-87-3	50.49	1.21	2.90E-02	98.0%	5.79E-04	2.54E-03
1,4 Dichlorobenzene (p-dichlorobenzene)	x	x	106-46-7	147	0.21	1.48E-02	98.0%	2.97E-04	1.30E-03
Dichlorodifluoromethane (CFC-12, freon-12)	--	--	75-71-8	120.91	15.7	9.00E-01	98.0%	1.80E-02	7.88E-02
Dichlorofluoromethane (freon-21)	--	--	75-43-4	102.92	2.62	1.28E-01	98.0%	2.56E-03	1.12E-02
Dichloromethane (methylene chloride)	x	--	75-09-2	84.93	14.3	5.76E-01	98.0%	1.15E-02	5.04E-02
Dimethyl Sulfide (methyl sulfide)	--	x	75-18-3	62.13	7.82	2.30E-01	98.0%	4.61E-03	2.02E-02
Ethane	--	--	74-84-0	30.07	889	1.27E+01	98.0%	2.53E-01	1.11E+00
Ethanol (ethyl alcohol)	--	x	64-17-5	46.08	27.2	5.94E-01	98.0%	1.19E-02	5.20E-02
Ethylbenzene ^o	x	x	100-41-4	106.17	4.61	2.32E-01	98.0%	4.64E-03	2.03E-02
Ethyl Mercaptan (ethanethiol)	--	x	75-08-1	62.13	1.25	3.68E-02	98.0%	7.36E-04	3.23E-03
Ethylene dibromide (1,2 dibromoethane)	x	x	106-93-4	187.88	0.001	8.91E-05	98.0%	1.78E-06	7.80E-06
Fluorotrichloromethane (CFC-11, freon-11)	--	--	75-69-4	137.37	0.76	4.95E-02	98.0%	9.90E-04	4.34E-03
Hexane	x	x	110-54-3	86.18	6.57	2.68E-01	98.0%	5.37E-03	2.35E-02
Hydrogen Sulfide ^e	--	--	7783-06-4	34.08	385.8	6.23E+00	99.9%	6.23E-03	2.73E-02
Mercury (total)	x	--	7439-97-6	200.61	2.92E-4	2.78E-05	0.0%	2.78E-05	1.22E-04
Methyl Ethyl Ketone (2-butanone)	--	--	78-93-3	72.11	7.09	2.42E-01	98.0%	4.85E-03	2.12E-02
Methyl Isobutyl Ketone (hexone)	x	x	108-10-1	100.16	1.87	8.88E-02	98.0%	1.78E-03	7.78E-03
Methyl Mercaptan	--	x	74-93-1	48.11	2.49	5.68E-02	98.0%	1.14E-03	4.97E-03
Pentane	--	x	109-66-0	72.15	3.29	1.13E-01	98.0%	2.25E-03	9.86E-03
ethene)	x	x	127-18-4	165.83	3.73	2.93E-01	98.0%	5.86E-03	2.57E-02
Propane	--	x	74-98-6	44.1	11.1	2.32E-01	98.0%	4.64E-03	2.03E-02
Toluene (methylbenzene)	x	x	108-88-3	92.14	39.3	1.72E+00	98.0%	3.43E-02	1.50E-01
Trichloroethylene (trichloroethene)	x	x	79-01-6	131.38	2.82	1.76E-01	98.0%	3.51E-03	1.54E-02
t - 1,2 - Dichloroethene (1,2 dichloroethylene)	--	--	156-60-5	96.94	2.84	1.31E-01	98.0%	2.61E-03	1.14E-02
Vinyl Chloride (chloroethylene, VCM)	x	x	75-01-4	62.50	7.34	2.17E-01	98.0%	4.35E-03	1.91E-02
Xylenes (m, o, p)	x	x	1330-20-7	106.17	12.1	6.09E-01	98.0%	1.22E-02	5.33E-02
Hydrogen Chloride ^e	x	--	7647-01-0	36.50	42.0	7.27E-01	0.0%	7.27E-01	3.18E+00
Total HAP ^a								0.82	3.6
Maximum Single HAP								0.73	3.18
Hydrogen Sulfide without BACT				34.08	5785.0	9.35E+01	99.9%	0.09	0.41

^aU.S. E.P.A., *Compilation of Air Pollutant Emission Factors, Volume I. Stationary Point and Area Sources ("AP-42")*, 5th Ed., November 1998.

^bAP-42 gives ranges for control efficiencies.

^cProduct of combustion

^dBecause HCl is a production of combustion, a default outlet concentration is listed; AP-42, Section 2.4.4.

^eControl Efficiency based on various references including; Canadian Centre for Occupational Health and Safety: CCOHS Chemical Name hydrogen Sulfide; October 3, 2005

**Emissions Calculations
Okeechobee (Berman Road) Landfill
Okeechobee, FI**

EU NEW - Proposed 3,000-scfm utility flare

Standard Conditions, Constants, and Typical Values

Category	Value	Equivalent
Standard Temperature ^a	60 °F	520 °R
Universal Gas Constant	0.7302	atm-ft ³ /lb-mol°R
Pressure ^a	1	atm
Methane Heating Value ^b	1,000	Btu/ft ³
LFG Methane Component ^c	50%	%
LFG Typical Heating Value	500	Btu/ft ³
LFG Temperature ^c	100 °F	560 °R
LFG Moisture ^c	8%	%

^aIndustrial STP (60°F, 30.00 in. Hg, 1 atm)

^bTypical

^cAssumed

Fuel & Equipment - Open Flare

Flare Information	Value	Equivalent
No. of Hours of Operation Per Day ^a	24	hr
No. of Days in Averaging Period ^a	365	day
Operation Period ^a	8,760	hr
LFG inlet flow, standard ^a	3,300	scfm
LFG Inlet Flow, dry standard	3,036	dscfm
Heat Input	99.0	MMBtu/hr
Design Flare Operating Temperature ^b	1,400 °F	1,860 °R
Flare Tip Flow, standard	3,300	scfm
Flare Tip Flow, actual	3,554	acfm
Flare Tip Diameter ^b	1.17	ft
Flare Tip Exhaust Velocity	3,324	ft/min
Flare Tip Height, above local grade ^b	35	ft

^aPermit Applicant

Criteria Pollutant Emissions - Open Flare

Operation Period	8,760	hr
LFG inlet flow, standard	3,300	scfm
Heat Input	99.0	MMBtu/hr

SO₂ Emission Rate								
SO ₂ concentration in exhaust gas	5800.25	ppmv						
SO ₂ emission rate	193.77	lb/hr	848.73	ton/yr				
LFG Compound	CAS	MW (lb/lb-mol)	Conc (ppmv) ^a	Control Eff ^{a,b}	Individual Compound Contribution to SO ₂			
					No. of S Atoms	S Conc (ppmv)	SO ₂ Emiss (lb/hr)	
Carbon Disulfide	75-15-0	76.13	0.58	100.0%	2	1.17	0.04	
Carbonyl Sulfide	463-58-1	60.07	0.49	100.0%	1	0.49	0.02	
Dimethyl Sulfide (methyl sulfide)	75-18-3	62.13	7.82	100.0%	1	7.82	0.26	
Ethyl Mercaptan (ethanethiol)	75-08-1	62.13	2.28	100.0%	1	2.28	0.08	
Hydrogen Sulfide	7783-06-4	34.08	5786.00	100.0%	1	5786.0	193.30	
Methyl Mercaptan	74-93-1	48.11	2.49	100.0%	1	2.49	0.08	
Total Contribution to SO ₂ :						5800.25	193.77	
SO₂ Emission Rate with BACT								
SO ₂ concentration in exhaust gas	400.05	ppmv						
SO ₂ emission rate	13.36	lb/hr	58.54	tpy				
Carbon Disulfide	75-15-0	76.13	0.58	100.0%	2	1.17	0.04	
Carbonyl Sulfide	463-58-1	60.07	0.49	100.0%	1	0.49	0.02	
Dimethyl Sulfide (methyl sulfide)	75-18-3	62.13	7.82	100.0%	1	7.82	0.26	
Ethyl Mercaptan (ethanethiol)	75-08-1	62.13	2.28	100.0%	1	2.28	0.08	
Hydrogen Sulfide	7783-06-4	34.08	385.80	100.0%	1	385.8	12.89	
Methyl Mercaptan	74-93-1	48.11	2.49	100.0%	1	2.49	0.08	
Total Contribution to SO ₂ :						400.05	13.36	
PM₁₀ Emission Rate								
PM emission factor ^a	17	lb/MM dscf CH ₄						
PM emission rate	1.55	lb/hr	6.78	tpy				
NO₂ Emission Rate								
NO ₂ emission factor ^p	0.068	lb/MMBtu						
NO ₂ emission rate	6.73	lb/hr	29.49	tpy				
CO Emission Rate								
CO emission factor ^p	0.37	lb/MMBtu						
CO emission rate	36.6	lb/hr	160.4	tpy				
NMOC Emission Rate								
NMOC conc inlet gas ^a	595	ppmv						
MW hexane	86.18	lb/lb-mol						
destruction efficiency	98%							
mass NMOC inlet gas	26.74	lb/hr						
NMOC emission rate	0.53	lb/hr	2.34	tpy				
VOC Emission Rate								
NMOC conc inlet gas ^a	595	ppmv						
VOC fraction of NMOC ^a	39%							
VOC concentration in inlet gas	232	ppmv						
MW hexane	86.18	lb/lb-mol						
mass VOC inlet gas	10.43	lb/hr						
destruction efficiency	98%							
VOC emission rate	0.21	lb/hr	0.91	tpy				

^aEPA 1998. "Compilation of Air Pollutant Emission Factors, Volume I. Stationary Point and Area Sources" (AP-42), 5th Ed., November

^bAP-42 gives ranges for control efficiencies.

Emissions Calculations
Okeechobee (Berman Road) Landfill
Okeechobee, FI

Air Toxics Emissions from Open Flare *The flare's inlet* 3,300 scfm

LFG Compound	HAP	CAS	MW (lb/lb-mol)	Compound Conc & Mass in Inlet Gas		Control Eff ^{a,b}	Flare Exhaust	
				(ppmv) ^a	(lb/hr)		(lb/hr)	(tpy)
1,1,1 - Trichloroethane (methyl chloroform)	x	71-55-6	133.41	0.48	3.34E-02	98.0%	6.68E-04	2.93E-03
1,1,2,2 - Tetrachloroethane	x	79-34-5	167.85	1.11	9.72E-02	98.0%	1.94E-03	8.51E-03
1,1,2 - Trichloroethane (1,1,2 TCA)	x	79-00-5	133.41	0.10	6.96E-03	98.0%	1.39E-04	6.09E-04
1,1 - Dichloroethane (ethylidene dichloride)	x	75-34-3	98.96	2.35	1.21E-01	98.0%	2.43E-03	1.06E-02
1,1 - Dichloroethane (vinylidene chloride)	x	75-35-4	96.94	0.20	1.02E-02	98.0%	2.03E-04	8.90E-04
1,2 - Dichloroethane (ethylene dichloride)	x	107-06-2	98.96	0.41	2.10E-02	98.0%	4.20E-04	1.84E-03
1,2 - Dichloropropane (propylene dichloride)	x	78-87-5	112.99	0.18	1.06E-02	98.0%	2.12E-04	9.29E-04
2-Propanol (isopropyl alcohol)	--	67-63-0	60.11	50.1	1.57E+00	98.0%	3.14E-02	1.38E-01
Acetone (2-propanone)	--	67-64-1	58.08	7.01	2.12E-01	98.0%	4.25E-03	1.86E-02
Acrylonitrile (Propenenitrile)	x	107-13-1	53.06	6.33	1.75E-01	98.0%	3.50E-03	1.53E-02
Benzene	x	71-43-2	78.12	1.91	7.78E-02	98.0%	1.56E-03	6.82E-03
Bromodichloromethane	--	75-27-4	163.83	3.13	2.67E-01	98.0%	5.35E-03	2.34E-02
Butane	--	106-97-8	58.12	5.03	1.52E-01	98.0%	3.05E-03	1.34E-02
Carbon Disulfide	x	75-15-0	76.14	0.58	2.31E-02	98.0%	4.63E-04	2.03E-03
Carbon Tetrachloride	x	56-23-5	153.84	0.004	3.21E-04	98.0%	6.42E-06	2.81E-05
Carbonyl Sulfide	x	463-58-1	60.07	0.49	1.53E-02	98.0%	3.07E-04	1.34E-03
Chlorobenzene (monochlorobenzene)	x	108-90-7	112.56	0.25	1.49E-02	98.0%	2.98E-04	1.31E-03
Chlorodifluoromethane (CFC-22, freon-22)	--	75-45-6	86.47	1.30	5.86E-02	98.0%	1.17E-03	5.13E-03
Chloroethane (ethyl chloride)	x	75-00-3	64.52	1.25	4.21E-02	98.0%	8.41E-04	3.68E-03
Chloroform (trichloromethane)	x	67-66-3	119.38	0.03	1.87E-03	98.0%	3.74E-05	1.64E-04
Chloromethane (methyl chloride)	x	74-87-3	50.49	1.21	3.19E-02	98.0%	6.37E-04	2.79E-03
1,4 Dichlorobenzene (p-dichlorobenzene)	x	106-46-7	147	0.21	1.63E-02	98.0%	3.27E-04	1.43E-03
Dichlorodifluoromethane (CFC-12, freon-12)	--	75-71-8	120.91	15.7	9.90E-01	98.0%	1.98E-02	8.67E-02
Dichlorofluoromethane (freon-21)	--	75-43-4	102.92	2.62	1.41E-01	98.0%	2.81E-03	1.23E-02
Dichloromethane (methylene chloride)	x	75-09-2	84.93	14.3	6.33E-01	98.0%	1.27E-02	5.55E-02
Dimethyl Sulfide (methyl sulfide)	--	75-18-3	62.13	7.82	2.53E-01	98.0%	5.07E-03	2.22E-02
Ethane	--	74-84-0	30.07	889	1.39E+01	98.0%	2.79E-01	1.22E+00
Ethanol (ethyl alcohol)	--	64-17-5	46.08	27.2	6.54E-01	98.0%	1.31E-02	5.73E-02
Ethylbenzene ^c	x	100-41-4	106.17	4.61	2.55E-01	98.0%	5.10E-03	2.24E-02
Ethyl Mercaptan (ethanethiol)	--	75-08-1	62.13	1.25	4.05E-02	98.0%	8.10E-04	3.55E-03
Ethylene dibromide (1,2 dibromoethane)	x	106-93-4	187.88	0.001	9.80E-05	98.0%	1.96E-06	8.58E-06
Fluorotrichloromethane (CFC-11, freon-11)	--	75-69-4	137.37	0.76	5.44E-02	98.0%	1.09E-03	4.77E-03
Hexane	x	110-54-3	86.18	6.57	2.95E-01	98.0%	5.91E-03	2.59E-02
Hydrogen Sulfide ^d	--	7783-06-4	34.08	385.8	6.86E+00	99.9%	6.86E-03	3.00E-02
Mercury (total)	x	7439-97-6	200.61	2.92E-4	3.05E-05	0.0%	3.05E-05	1.34E-04
Methyl Ethyl Ketone (2-butanone)	--	78-93-3	72.11	7.09	2.67E-01	98.0%	5.33E-03	2.34E-02
Methyl Isobutyl Ketone (hexone)	x	108-10-1	100.16	1.87	9.77E-02	98.0%	1.95E-03	8.56E-03
Methyl Mercaptan	--	74-93-1	48.11	2.49	6.25E-02	98.0%	1.25E-03	5.47E-03
Pentane	--	109-66-0	72.15	3.29	1.24E-01	98.0%	2.48E-03	1.08E-02
ethene)	x	127-18-4	165.83	3.73	3.23E-01	98.0%	6.45E-03	2.83E-02
Propane	--	74-98-6	44.1	11.1	2.55E-01	98.0%	5.11E-03	2.24E-02
Toluene (methylbenzene)	x	108-88-3	92.14	39.3	1.89E+00	98.0%	3.78E-02	1.65E-01
Trichloroethylene (trichloroethene)	x	79-01-6	131.38	2.82	1.93E-01	98.0%	3.86E-03	1.69E-02
t - 1,2 - Dichloroethene (1,2 dichloroethylene)	--	156-60-5	96.94	2.84	1.44E-01	98.0%	2.87E-03	1.26E-02
Vinyl Chloride (chloroethylene, VCM)	x	75-01-4	62.50	7.34	2.39E-01	98.0%	4.78E-03	2.10E-02
Xylenes (m, o, p)	x	1330-20-7	106.17	12.1	6.70E-01	98.0%	1.34E-02	5.87E-02
Hydrogen Chloride ^e	x	7647-01-0	36.50	42.0	7.99E-01	0.0%	7.99E-01	3.50E+00
Total HAP							0.91	3.97
Maximum Single HAP							0.80	3.50
Hydrogen Sulfide without BACT			34.08	5785.0	1.03E+02	99.9%	0.10	0.45

^aU.S. E.P.A., *Compilation of Air Pollutant Emission Factors, Volume I. Stationary Point and Area Sources ("AP-42")*, 5th Ed., November 1998.

^bAP-42 gives ranges for control efficiencies.

^cProduct of combustion

^dBecause HCl is a production of combustion, a default outlet concentration is listed; AP-42, Section 2.4.4.

^eControl Efficiency based on various references including; Canadian Centre for Occupational Health and Safety: CCOHS Chemical Name hydrogen Sulfide; October 3, 2005

EU003 - 3,000-scfm enclosed flare w/evap
E-VAP UNIT #3016

Emissions Calculations
Okeechobee (Berman Road) Landfill
Okeechobee, FL

THEORETICAL ORGANIC/METAL/OTHER CONCENTRATIONS and EMISSIONS

Leachate input Rate (gallons/day) = 30,000 gpd 0.030 MGD

COMPOUND	HAP	8/19/1998	4/29/1998	2/5/1998	11/5/1997	11/5/97 (a)	11/5/97 (a)	Maximum	EPA Theoretical Median Conc ⁽¹⁾ (mg/l)	EPA Theoretical Median Conc ⁽¹⁾ (ug/l)	Number of Samples by EPA	Max Conc (mg/l)	Pounds per hour	Pounds per year
		ppm ^b (mg/l)	ppm ^b (mg/l)	ppm ^b (mg/l)	ppm ^b (mg/l)	ppm ^b (mg/l)	ppb ^b (ug/l)	ppm ^b (mg/l)						
1,1 Dichloroethane (ethylidene dichloride)	*					0.0000		0.000	0.165	165	34	0.165	1.72E-3	15.08
1,1,1 Trichloroethane	*	5.00				0.0000		5.000	0	86	0	0.0000	0.00E+0	-
1,1,2 Trichloroethane	*					0.0000		0.000	0.086	426	20	5.0000	5.22E-2	456.85
1,1,2,2 Tetrachloroethane	*					0.0000		0.000	0.426	210	4	0.4260	4.44E-3	38.92
1,2 Dichloroethane (ethylene dichloride)	*					0.0000		0.000	0.21	10	1	0.2100	2.19E-3	19.19
1,2 Dichloropropane (propylene dichloride)	*					0.0000		0.000	0.01	9	6	0.0100	1.04E-4	0.91
1,2 trans dichloroethylene	*					0.0000		0.000	0.009	92	12	0.0090	9.39E-5	0.82
1,2,3 Trichloropropane	*					0.0000		0.000	0.092	230	40	0.0920	9.60E-4	8.41
1-Propanol						0.0000		0.000	0.23	11000	1	0.2300	2.40E-3	21.02
2,4-dimethylphenol						0.0000		0.000	11	19	1	11.0000	1.15E-1	1,005.08
2-Chloroethyl Vinyl Ether						0.0000		0.000	0.019	551	2	0.0190	1.98E-4	1.74
2-Hexanone						0.0000		0.000	0.551	88	2	0.5510	5.75E-3	50.35
Acetone						0.0880	88.00	0.088	0.088	430	11	0.0880	9.18E-4	8.04
Acrolein	*					0.0000		0.000	0.43	270	23	0.4300	4.49E-3	39.29
Acrylonitrile	*					0.0000		0.000	0.27	270	1	0.2700	2.82E-3	24.67
Benzene	*					0.0003	0.27	0.00027	0	37	35	0.0370	3.86E-4	3.38
Bis(Chloromethyl) Ether	*					0.0000		0.000	0.25	250	1	0.2500	2.61E-3	22.84
Butanol						0.0000		0.000	10	10000	1	10.0000	1.04E-1	913.71
Carbon tetrachloride	*					0.0000		0.000	0.202	202	2	0.2020	2.11E-3	18.46
Chlorobenzene	*					0.0000		0.000	0.007	7	12	0.0070	7.30E-5	0.64
Chloroform	*					0.0000		0.000	0.029	29	8	0.0290	3.02E-4	2.65
Chloromethane	*					0.0000		0.000	0.175	175	3	0.1750	1.83E-3	15.99
Cis- 1,2 Dichloroethylene						0.0000		0.000	0.33	330	2	0.3300	3.44E-3	30.15
Dichloromethane (methylene chloride)	*					0.0000		0.000	0.44	440	68	0.4400	4.59E-3	40.20
Diethyl phthalate						0.0000		0.000	0	83	0	0.0000	0.00E+0	-
Ethanol						0.0000		0.000	0.083	83	27	0.0830	8.66E-4	7.58
Ethylbenzene	*	3.00				0.0010	1.00	3.000	23	23000	1	23.0000	2.40E-1	2,101.53
Isophorone	*					0.0000		0.000	0.058	76	41	3.0000	3.13E-2	274.11
Methyl ethyl ketone	*					0.1900	190.00	0.190	0.076	76	19	0.0760	7.93E-4	6.94
Methyl isobutyl ketone	*					0.0280	28	0.028	1.55	1550	24	1.5500	1.62E-2	141.62
Naphthalene	*					0.0000		0.000	0.27	270	9	0.2700	2.82E-3	24.67
p-Cresol	*					0.0000		0.000	0.012	12	23	0.0120	1.25E-4	1.10
Perchloroethylene (tetrachloroethylene)	*					0.0000		0.000	2.305	2305	10	2.3050	2.40E-2	210.61
Phenols (total)	*					0.0000		0.000	0.055	55	18	0.0550	5.74E-4	5.03
Styrene	*					0.0000		0.000	0.378	378	45	0.3780	3.94E-3	34.54
Tetrahydrofuran						0.0000		0.000	0	0	0	0.0000	0.00E+0	-
Toluene	*	5.00		4.00	2.00	0.0026	2.60	5.000	0.26	260	7	0.2600	2.71E-3	23.76
Trichloroethylene	*					0.0000		0.000	0.413	413	69	5.0000	5.22E-2	456.85
Vinyl chloride	*					0.0000		0.000	0.043	43	28	0.0430	4.49E-4	3.93
Xylene	*	9.00				0.0022	2.20	9.000	0.04	40	10	0.0400	4.17E-4	3.65

Total HAP: 2.46E-1 2,156.07

Notes:
HAP = Clean Air Act Hazardous Air Pollutant
mgal = million gallons
Parts per billion = ug/l
Parts per million = mg/l

x - detected below method detection limit

(1) Using EPA "typical" leachate data (median value), Summary Of Data On Municipal Solid Waste Landfill Leachate Characteristics "Criteria For Municipal Solid Waste Landfills".

EPA, July 1988 (NTIS PB88-242441).

Emissions Calculations
Okeechobee (Berman Road) Landfill
Okeechobee, FL

	HAP	8/19/1998 ppm ^b (mg/l)	4/29/1998 ppm ^b (mg/l)	2/5/1998 ppm ^b (mg/l)	11/5/1997 ppm ^b (mg/l)	11/5/97 (a) ppm ^b (mg/l)	11/5/97 (a) ppb ^b (ug/l)	Maximum ppm ^b (mg/l)	EPA Theoretical Median Conc (mg/l)	EPA Theoretical Conc (ug/l)	Number of Samples by EPA	Max Conc (mg/l)	Pounds per hour	Pounds per year
Hydrogen Chloride ^(d)	*	660.00	320.00	260.00				660.000	695	695000	0	695.000	-	N/A
Hydrogen fluoride						200.00		200.000	0.4	400	0	200.000	-	N/A
Hydrogen sulfide ^(e)		96.00	8.00					96.000	108	108000	0	108.000	1.13E+0	9,868.04

	HAP	8/19/1998 ppm ^b (mg/l)	4/29/1998 ppm ^b (mg/l)	2/5/1998 ppm ^b (mg/l)	11/5/1997 ppm ^b (mg/l)	11/5/97 (a) ppm ^b (mg/l)	11/5/97 (a) ppb ^b (ug/l)	Maximum ppm ^b (mg/l)	EPA Theoretical Median Conc (mg/l)	EPA Theoretical Conc (ug/l)	Number of Samples by EPA	Max Conc (mg/l)	Pounds per hour	Pounds per year
Leachate HAPs & metals^c														
Bis (Chloromethyl) ether	*					0.0000		0.000	0		0	0.000	0.00E+0	0.0
Isophorone	*					0.0000		0.000	0		0	0.000	0.00E+0	0.0
Naphthalene	*					0.0000		0.000	0		0	0.000	0.00E+0	0.0
p-cresol	*					0.0000		0.000	0		0	0.000	0.00E+0	0.0
phenols (total)	*					0.0000		0.000	0		0	0.000	0.00E+0	0.0
antimony	*					0.0000		0.000	0		0	0.000	0.00E+0	0.0
arsenic	*					0.0000		0.000	0.08		0	0.080	8.34E-7	0.0
barium	*	0.17	0.06	0.06	0.08	0.0000		0.170	0.383	383	0	0.383	3.99E-6	0.0
beryllium	*					0.0000		0.000	0.0065	7	0	0.007	6.78E-8	0.0
cadmium	*					0.0000		0.000	0.015	15	0	0.015	1.56E-7	0.0
calcium	*	135.00	21.00	25.00	27.00	0.0000		135.000	336	336000	0	336.000	3.50E-3	30.7
chromium	*	0.17				0.0000		0.170	0.06	60	0	0.170	1.77E-6	0.0
copper	*	0.10				0.0420	42.00	0.100	0.07	70	0	0.100	1.04E-6	0.0
lead	*					0.0000		0.000	0.08	80	0	0.080	8.34E-7	0.0
mercury	*					0.0000		0.000	0.0006	0.6	0	0.001	6.26E-9	0.0
nickel	*	0.20	0.03	0.02	0.02	0.0000		0.200	0.16	160	0	0.200	2.09E-6	0.0
selenium	*					0.0000		0.000		0	0	0.000	0.00E+0	0.0
sodium	*	510.00	260.00	330.00	440.00	0.0000		510.000		0	0	510.000	5.32E-3	46.6
thallium	*					0.0000		0.000		0	0	0.000	0.00E+0	0.0
iron	*	6.00				3.6000	3600.00	6.000	66.2	66200	0	66.200	6.90E-4	6.0
zinc	*	0.07				0.0750	75.00	0.075	1.35	1350	0	1.350	1.41E-5	0.1

TOTAL HAP EMISSIONS:

a - HAPs in both LFG and in leachate

b - from EPA Characterization of MWC Ashes and Leachates from MSW Landfills,

Monofills and Co-Disposal Sites, median concentration values

c - draft AP-42 (9/95), Tables 2.4-3; unlisted control efficiencies assumed to be 80%

d - product of combustion

e - Additional HAPs found in leachate > 50 ppb/mgal per reference b

x - HAP present in leachate > 50 ppb

o - non-VOC HAP

Notes

c - draft AP-42 (9/95), Tables 2.4-1 and 2.4-2; concentration in inlet gas

d - concentration of chloride in leachate; thermal conversion to hydrogen chloride in flare is presented in the "air toxics" sheets

d - concentration of sulfate in leachate; thermal conversion to sulfur dioxides in flare is presented in the "criteria pollutants" sheets

uncontrolled = **0.30** #####
lb/hr lbs/year
98% control = **0.006** **52.92**
lb/hr lbs/year

EU005 3,000-scfm enclosed flare w/evap
E-VAP UNIT #PROPOSED on existing flare

THEORETICAL ORGANIC/METAL/OTHER CONCENTRATIONS and EMISSIONS

Leachate input Rate (gallons/day) = 30,000 gpd 0.030 MGD

COMPOUND	HAP	8/19/1998	4/29/1998	2/5/1998	11/5/1997	11/5/97 (a)	11/5/97 (a)	Maximum	EPA Theoretical Median Conc ⁽¹⁾ (mg/l)	EPA Theoretical Median Conc ⁽¹⁾ (ug/l)	Number of Samples by EPA	Max Conc (mg/l)	Pounds per hour	Pounds per year
		ppm ^b (mg/l)	ppm ^b (mg/l)	ppm ^b (mg/l)	ppm ^b (mg/l)	ppm ^b (mg/l)	ppb ^b (ug/l)	ppm ^b (mg/l)						
1,1 Dichloroethane (ethylene dichloride)	*					0.0000		0.000	0.165	165	34	0.165	1.72E-3	15.08
1,1,1 Trichloroethane	*	5.00				0.0000		5.000	0		0	0.0000	0.00E+0	-
1,1,2 Trichloroethane	*					0.0000		0.000	0.086	86	20	5.0000	5.22E-2	456.85
1,1,2,2 Tetrachloroethane	*					0.0000		0.000	0.426	426	4	0.4260	4.44E-3	38.92
1,2 Dichloroethane (ethylene dichloride)	*					0.0000		0.000	0.21	210	1	0.2100	2.19E-3	19.19
1,2 Dichloropropane (propylene dichloride)	*					0.0000		0.000	0.01	10	6	0.0100	1.04E-4	0.91
1,2 trans dichloroethylene						0.0000		0.000	0.009	9	12	0.0090	9.39E-5	0.82
1,2,3 Trichloropropane						0.0000		0.000	0.092	92	40	0.0920	9.60E-4	8.41
1-Propanol						0.0000		0.000	0.23	230	1	0.2300	2.40E-3	21.02
2,4-dimethylphenol						0.0000		0.000	11	11000	1	11.0000	1.15E-1	1,005.08
2-Chloroethyl Vinyl Ether						0.0000		0.000	0.019	19	2	0.0190	1.98E-4	1.74
2-Hexanone						0.0000		0.000	0.551	551	2	0.5510	5.75E-3	50.35
Acetone						0.0880	88.00	0.088	0.088	88	11	0.0880	9.18E-4	8.04
Acrolein	*					0.0000		0.000	0.43	430	23	0.4300	4.49E-3	39.29
Acrylonitrile	*					0.0000		0.000	0.27	270	1	0.2700	2.82E-3	24.67
Benzene	*					0.0003	0.27	0.00027	0		0	0.0000	0.00E+0	-
Bis(Chloromethyl) Ether	*					0.0000		0.000	0.037	37	35	0.0370	3.86E-4	3.38
Butanol						0.0000		0.000	0.25	250	1	0.2500	2.61E-3	22.84
Carbon tetrachloride	*					0.0000		0.000	10	10000	1	10.0000	1.04E-1	913.71
Chlorobenzene	*					0.0000		0.000	0.202	202	2	0.2020	2.11E-3	18.46
Chloroform	*					0.0000		0.000	0.007	7	12	0.0070	7.30E-5	0.64
Chloromethane	*					0.0000		0.000	0.029	29	8	0.0290	3.02E-4	2.65
Cis- 1,2 Dichloroethylene						0.0000		0.000	0.175	175	3	0.1750	1.83E-3	15.99
Dichloromethane (methylene chloride)	*					0.0000		0.000	0.33	330	2	0.3300	3.44E-3	30.15
Diethyl phthalate						0.0000		0.000	0.44	440	68	0.4400	4.59E-3	40.20
Ethanol						0.0000		0.000	0		0	0.0000	0.00E+0	-
Ethylbenzene	*	3.00				0.0010	1.00	3.000	0.083	83	27	0.0830	8.66E-4	7.58
Isophorone	*					0.0000		0.000	23	23000	1	23.0000	2.40E-1	2,101.53
Methyl ethyl ketone	*					0.1900	190.00	0.190	0.058	58	41	3.0000	3.13E-2	274.11
Methyl isobutyl ketone	*					0.0280	28	0.028	0.076	76	19	0.0760	7.93E-4	6.94
Naphthalene	*					0.0000		0.000	1.55	1550	24	1.5500	1.62E-2	141.62
p-Cresol	*					0.0000		0.000	0.27	270	9	0.2700	2.82E-3	24.67
Perchloroethylene (tetrachloroethylene)	*					0.0000		0.000	0.012	12	23	0.0120	1.25E-4	1.10
Phenols (total)	*					0.0000		0.000	2.305	2305	10	2.3050	2.40E-2	210.61
Styrene	*					0.0000		0.000	0.055	55	18	0.0550	5.74E-4	5.03
Tetrahydrofuran	*					0.0000		0.000	0.378	378	45	0.3780	3.94E-3	34.54
Toluene	*	5.00		4.00	2.00	0.0026	2.60	5.000	0		0	0.0000	0.00E+0	-
Trichloroethylene	*					0.0000		0.000	0.26	260	7	0.2600	2.71E-3	23.76
Vinyl chloride	*					0.0000		0.000	0.413	413	69	5.0000	5.22E-2	456.85
Xylene	*	9.00				0.0022	2.20	9.000	0.043	43	28	0.0430	4.49E-4	3.93

Notes:
HAP = Clean Air Act Hazardous Air Pollutant
mgal = million gallons
Parts per billion = ug/l
Parts per million = mg/l

Emissions Calculations
Okeechobee (Berman Road) Landfill
Okeechobee, FL

x - detected below method detection limit

(1) Using EPA "typical" leachate data (median value), Summary Of Data On Municipal Solid Waste Landfill Leachate Characteristics "Criteria For Municipal Solid Waste Landfills",

EPA, July 1988 (NTIS PB88-242441).

	HAP	8/19/1998 ppm ^b (mg/l)	4/29/1998 ppm ^b (mg/l)	2/5/1998 ppm ^b (mg/l)	11/5/1997 ppm ^b (mg/l)	11/5/97 (a) ppm ^b (mg/l)	11/5/97 (a) ppb ^b (ug/l)	Maximum ppm ^b (mg/l)	EPA Theoretical Median Conc (mg/l)	EPA Theoretical Conc (ug/l)	Number of Samples by EPA	Max Conc (mg/l)	Pounds per hour	Pounds per year
Hydrogen Chloride ^(d)	*	660.00	320.00	260.00				660.000	695	695000	0	695.000	-	N/A
Hydrogen fluoride						200.00		200.000	0.4	400	0	200.000	-	N/A
Hydrogen sulfide ^(e)		96.00	8.00					96.000	108	108000	0	108.000	1.13E+0	9,868.04

	HAP	8/19/1998 ppm ^b (mg/l)	4/29/1998 ppm ^b (mg/l)	2/5/1998 ppm ^b (mg/l)	11/5/1997 ppm ^b (mg/l)	11/5/97 (a) ppm ^b (mg/l)	11/5/97 (a) ppb ^b (ug/l)	Maximum ppm ^b (mg/l)	EPA Theoretical Median Conc (mg/l)	EPA Theoretical Conc (ug/l)	Number of Samples by EPA	Max Conc (mg/l)	Pounds per hour	Pounds per year
Leachate HAPs & metals^c														
Bis (Chloromethyl) ether	*					0.0000		0.000	0		0	0.000	0.00E+0	0.0
Isophorone	*					0.0000		0.000	0		0	0.000	0.00E+0	0.0
Naphthalene	*					0.0000		0.000	0		0	0.000	0.00E+0	0.0
p-cresol	*					0.0000		0.000	0		0	0.000	0.00E+0	0.0
phenols (total)	*					0.0000		0.000	0		0	0.000	0.00E+0	0.0
antimony	*					0.0000		0.000	0		0	0.000	0.00E+0	0.0
arsenic	*					0.0000		0.000	0.08		0	0.080	8.34E-7	0.0
barium		0.17	0.06	0.06	0.08	0.0000		0.170	0.383	383	0	0.383	3.99E-6	0.0
beryllium	*					0.0000		0.000	0.0065	7	0	0.007	6.78E-8	0.0
cadmium	*					0.0000		0.000	0.015	15	0	0.015	1.56E-7	0.0
calcium		135.00	21.00	25.00	27.00	0.0000		135.000	336	336000	0	336.000	3.50E-3	30.7
chromium	*	0.17				0.0000		0.170	0.06	60	0	0.170	1.77E-6	0.0
copper	*	0.10				0.0420	42.00	0.100	0.07	70	0	0.100	1.04E-6	0.0
lead	*					0.0000		0.000	0.08	80	0	0.080	8.34E-7	0.0
mercury	*					0.0000		0.000	0.0006	0.6	0	0.001	6.26E-9	0.0
nickel	*	0.20	0.03	0.02	0.02	0.0000		0.200	0.16	160	0	0.200	2.09E-6	0.0
selenium	*					0.0000		0.000		0	0	0.000	0.00E+0	0.0
sodium		510.00	260.00	330.00	440.00	0.0000		510.000		0	0	510.000	5.32E-3	46.6
thallium						0.0000		0.000		0	0	0.000	0.00E+0	0.0
iron		6.00				3,6000	3600.00	6.000	66.2	66200	0	66.200	6.90E-4	6.0
zinc		0.07				0.0750	75.00	0.075	1.35	1350	0	1.350	1.41E-5	0.1

TOTAL HAP EMISSIONS:

a - HAPs in both LFG and in leachate

b - from EPA Characterization of MWC Ashes and Leachates from MSW Landfills,

Monofills and Co-Disposal Sites, median concentration values

c - draft AP-42 (9/95), Tables 2.4-3; unlisted control efficiencies assumed to be 80%

d - product of combustion

c - Additional HAPs found in leachate > 50 ppb/mgal per reference b

x - HAP present in leachate > 50 ppb

o - non-VOC HAP

Notes:

c - draft AP-42 (9/95), Tables 2.4-1 and 2.4-2; concentration in inlet gas

d - concentration of chloride in leachate; thermal conversion to hydrogen chloride in flare is presented in the "air toxics" sheets

d - concentration of sulfate in leachate; thermal conversion to sulfur dioxides in flare is presented in the "criteria pollutants" sheets

uncontrolled = **0.30** **2,646.05**

lb/hr lbs/year

98% control = **0.006** **52.92**

lb/hr lbs/year

Note: Existing 20,000-gpd EVAP unit contributed 35.3 lb/yr. Increase for new unit =

35.3

Letter Symbol	Definition
atm-ft ³ /lb-mol ^o R	atmosphere cubic foot per pound mole degree Rankine
acfm	actual cubic foot per minute
atm	atmosphere
bhp	brake horsepower
Btu	british thermal unit
cal/s	calorie per second
CO	carbon monoxide
ft ³	cubic foot
m ³	cubic meter
d	day
°F	degree Fahrenheit
°R	degree Rankine
dscfm	dry standard cubic foot, feet per minute
dsl/min	dry standard litre per minute
ft	foot
ft/min	foot per minute
ft/s	foot per second
g	gram
hr	hour
HAP	hazardous air pollutant
HV	heating value
HHV	higher heating value
in.	inch
kW	kilowatt
kWh	kilowatt hour
l	litre
LHV	lower heating value
m	meter
m/s	meter per second
CH ₄	methane
Hg	mercury
µg	microgram
µg/dsl	microgram per dry standard litre
mg	milligram
MM	million
MMBtu	million british thermal units
min	minute
mol	mole
NO ₂	nitrogen dioxide
Nox	nitrogen oxides
NMOC	non-methane organic compounds
PM ₁₀	particulate matter less than or equal to 10 microns
Pb	lead
ppmv	parts per million by volume
ppmw	parts per million by weight
lb/hr	pound per hour
s	second
scf	standard cubic foot
scfm	standard cubic foot per minute
STP	standard temperature and pressure
SO ₂	sulfur dioxide
ton	ton
ton/yr	ton per year
R	universal gas constant
VOC	volatile organic compound

**Emissions Calculations
Okeechobee (Berman Road) Landfill
Okeechobee, FL**

Sample Calculations

Standard Conditions and Constants

$$^{\circ}\text{R} = ^{\circ}\text{F} + 460$$

$$\text{standard temperature} = 60 \text{ }^{\circ}\text{F}$$

$$\text{standard pressure} = 1 \text{ atm}$$

$$\text{Universal gas constant (R)} = 0.7302 \text{ atm}\cdot\text{ft}^3/\text{lb}\cdot\text{mol}\cdot^{\circ}\text{R}$$

Flow

$$\text{dscfm} = \text{scfm} \cdot (1 - \% \text{moisture})$$

$$\text{acfm} = \text{scfm} \cdot (\text{actual temp}[^{\circ}\text{R}] / (\text{standard temp}[^{\circ}\text{R}]) \cdot \{(\text{standard press}[\text{atm}] / (\text{actual press} [\text{atm}]))\}$$

CO and NO_x Emissions

$$(\text{lb/MMbtu}) \cdot (\text{MMbtu/hr}) = \text{lb/hr}$$

SO₂ Emissions

typically, 86% to 99.7% of sulfur compounds convert to SO₂ during combustion

$$\{(\text{scfm}) \cdot (60 \text{ min/hr}) \cdot (\text{total sulfur concentration} [\text{ppmv}]) \cdot (1 - \text{control efficiency}) \cdot (\text{MW SO}_2)\} / \{(R) \cdot (T)\} = \text{lb/hr}$$

PM₁₀ Emissions

$$(\text{dscfm}) \cdot (\text{CH}_4 \text{ component}) \cdot (1\text{E-}6 \text{ MMscf/scf}) \cdot (\text{lb PM/MMscf CH}_4) \cdot (60 \text{ min/hr}) = \text{lb/hr}$$

VOC Emissions

$$\{(\text{scfm} \cdot 60 \text{ min/hr} \cdot \text{concentration}_{\text{compound}} [\text{ppmv}] \cdot \text{MW}_{\text{compound}})\} / \{(R) \cdot (T)\} \cdot (1 - \text{control efficiency}) = \text{lb/hr}$$

OR

VOCs are 39 percent of NMOC, as prescribed in AP-42

$$\text{VOC concentration} [\text{ppmv}] = \text{NMOC concentration} [\text{as hexane}] \cdot 39\%$$

flare and/or engines typically combust 98% of VOCs

$$\{(\text{scfm} \cdot 60 \text{ min/hr} \cdot \text{concentration}_{\text{hexane}} [\text{ppmv}] \cdot \text{MW}_{\text{hexane}})\} / \{(R) \cdot (T)\} \cdot (0.39) = \text{lb/hr}$$

LFG Compound Emissions

$$\{(\text{scfm} \cdot 60 \text{ min/hr} \cdot \text{concentration}_{\text{compound}} [\text{ppmv}] \cdot \text{MW}_{\text{compound}})\} / \{(R) \cdot (T)\} \cdot (1 - \text{control efficiency})$$

HCl Emissions

typically, 86% to 99.7% of chlorine compounds convert to HCl during combustion

(concentration_{compound} [ppm]) · (control efficiency) · (no. of chlorine atoms) = HCl concentration [ppm] in outlet gas from each compound

$$\{\text{HCl concentration}_{\text{each compound}} [\text{ppm}] \cdot \text{scfm} \cdot \text{MW}_{\text{HCl}}\} / \{(R) \cdot (T)\} \cdot (60 \text{ min/hr}) = \text{lb/hr}$$

OR

$$\{(\text{scfm}) \cdot (60 \text{ min/hr}) \cdot (\text{HCl outlet concentration per AP-42} [\text{ppmv}]) \cdot (1 - \text{control efficiency}) \cdot (\text{MW})\} / \{(R) \cdot (T)\} = \text{lb/hr}$$

**Emissions Calculations
Okeechobee (Berman Road) Landfill
Okeechobee, FL**

Sample Calculations

Standard Conditions and Constants

$^{\circ}R = ^{\circ}F + 460$
standard temperature = 60 $^{\circ}F$
standard pressure = 1 atm
Universal gas constant (R) = 0.7302 atm-ft³/lb-mol $^{\circ}R$

Flow

dscfm = scfm*(1-%moisture)
acfm = scfm*(actual temp[$^{\circ}R$]/(standard temp[$^{\circ}R$])*{(standard press[atm])/(actual press [atm])})

CO and NO_x Emissions

(lb/MMbtu)*(MMbtu/hr) = lb/hr

SO₂ Emissions

typically, 86% to 99.7% of sulfur compounds convert to SO₂ during combustion
{(scfm)*(60 min/hr)*(total sulfur concentration [ppmv])*(1-control efficiency)*(MW SO₂)} / {(R)*(T)} = lb/hr

PM₁₀ Emissions

(dscfm)*(CH₄ component)*(1E-6 MMscf/scf)* (lb PM/MMscf CH₄)*(60 min/hr) = lb/hr

VOC Emissions

{(scfm*60 min/hr*concentration_{compound}[ppmv]*MW_{compound})/{(R)*(T)}*(1-control efficiency) = lb/hr
OR

VOCs are 39 percent of NMOC, as prescribed in AP-42

VOC concentration[ppmv] = NMOC concentration[as hexane]*39%

flare and/or engines typically combust 98% of VOCs

{(scfm*60 min/hr*concentration_{hexane}[ppmv]*MW_{hexane})/{(R)*(T)}*(0.39) = lb/hr

LFG Compound Emissions

{(scfm*60 min/hr*concentration_{compound}[ppmv]*MW_{compound})/{(R)*(T)}*(1-control efficiency)

HCl Emissions

typically, 86% to 99.7% of chlorine compounds convert to HCl during combustion

(concentration_{compound} [ppm])*(control efficiency)*(no. of chlorine atoms) = HCl concentration [ppm] in outlet gas from each compound

{HCl concentration_{each compound} [ppm]*scfm*MW_{HCl}}/{(R)*(T)}*(60 min/hr) = lb/hr

OR

{(scfm)*(60 min/hr)*(HCl outlet concentration per AP-42 [ppmv])*(1-control efficiency)*(MW)} / {(R)*(T)} = lb/hr

**Emissions Calculations
Okeechobee (Berman Road) Landfill
Okeechobee, FL**

INTENTIONALLY LEFT BLANK

Emissions Calculations
BASELINE ACTUAL EMISSIONS

Okeechobee Landfill
Okeechobee, Florida

Control Devices	Average 24-month flow rate (scfm)	24-month period Hours of Operation	Units	Calculated Emissions								
				NO ₂	CO	SO ₂	PM ₁₀	NMOC	VOC	Total HAPs	Single HAP	H ₂ S
Enclosed Flare Unit 1	2237	16902	lb/hr	3.66	12.2	132	0.95	0.36	0.14	0.61	0.54	0.07
			tpy	15.5	51.5	1,113	4.03	1.53	0.60	2.59	2.29	0.30
Enclosed Flare Unit 2	2246	17168	lb/hr	3.67	12.2	132	0.96	0.36	0.14	0.62	0.54	0.07
			tpy	15.8	52.6	1,134	4.11	1.56	0.61	2.65	2.34	0.30
Open Flare (Backup)	2240	847	lb/hr	4.57	24.87	131.89	1.06	0.37	0.15	0.61	0.54	0.08
			tpy	1.0	5.3	55.8	0.2	0.1	0.0	0.1	0.1	0.0
Open Flare (Odor Control)	764	5150	lb/hr	1.56	8.49	45.00	0.36	0.13	0.05	0.21	0.19	0.03
			tpy	2.01	10.93	115.88	0.46	0.17	0.06	0.27	0.24	0.04
TOTAL Baseline Actual for EU-001	7487		lb/hr	13.5	57.8	440.6	3.3	1.2	0.5	2.1	1.8	0.3
			tpy	34	120	2,418	8.8	3.3	1.3	5.6	5.0	0.7

Current Operating Permit has two allowable emissions: 1) NMOC is a 98% destruction efficiency and 2) CO is limited to 27 lb/MMBtu per emission unit and 250 tpy facility emission limit

Enclosed Flares: Existing

Description	LFG Flow (scfm)	Units	Calculated Emissions								
			NO ₂	CO	SO ₂	PM ₁₀	NMOC	VOC	Total HAPs	Single HAP	H ₂ S
Enclosed Flare Unit 1	2,237	lb/hr	3.66	12.2	132	0.95	0.36	0.14	0.61	0.54	0.07
		tpy	15.5	51.5	1,113	4.03	1.53	0.60	2.59	2.29	0.30
Enclosed Flare-Unit 2	2,246	lb/hr	3.67	12.2	132	0.96	0.36	0.14	0.62	0.54	0.07
		tpy	15.8	52.6	1,134	4.11	1.56	0.61	2.65	2.34	0.30

**EU003 3,000-scfm enclosed flare w/evap
 Unit #1 - Summary of Field Collected Data
 Flare Operation June 2004 - June 2006**

Month	Operational (hours)	Downtime (hours)	Total (hours)	Average CH4 (%)	Average Flow (scfm) To Flare	Average Flow (scfm) To EVAP	Average Flow (scfm) Total
July	742.37	1.63	744	55.1	1,894	235	2,129
August	730.22	13.78	744	57.9	1,886	275	2,161
September	618.12	101.88	720	52.9	1,755	241	1,996
October	724.67	19.33	744	54	1,664	294	1,958
November	709.5	10.5	720	52.6	1,552	300	1,852
December	729.38	14.62	744	50.6	1,293	229	1,522
January (05)	739.35	4.65	744	50.7	1,358	194	1,552
February	669.58	2.42	672	54.3	1,641	255	1,896
March	740.08	3.92	744	53.1	1,632	268	1,900
April	718.92	1.08	720	51.1	1,557	314	1,871
May	735.13	8.87	744	43.9	1,524	357	1,881
June	710.5	9.5	720	46.4	1,515	322	1,837
July	740.35	3.65	744	47.8	1,521	316	1,837
August	734.32	9.68	744	48	1,594	314	1,908
September	709.73	10.27	720	45.3	1,881	315	2,196
October	670.45	73.55	744	42	2,188	275	2,463
November	716.25	3.75	720	44.7	1,964	164	2,128
December	738.57	5.43	744	43.3	1,904	233	2,137
January (06)	738.35	5.65	744	46.2	2075	241	2316
February	667.43	4.57	672	43.8	2099	258	2357
March	737.25	6.75	744	42	2064	251	2315
April	570.4	149.6	720	41.1	2388	261	2649
May	738.22	5.78	744	39.2	2493	258	2751
June	713.9	6.1	720	38.5	2632	277	2909
July	744.00	0.00	744	42.7	2210	331	2540
August	656.42	87.58	744	45.0	2397	288	2685
September	709.12	10.88	720	49.0	2060	290	2350
October	567.77	176.23	744	46.5	2022	262	2285
November	700.17	19.83	720	46.4	1879	249	2128
December	737.33	6.67	744	47.4	1900	273	2173
January (07)	737.93	6.07	744	42.9	1845	251	2173
Highest 24-Month Total/ AVERAGES:	16902	618	17520	47.7	1836	276	2237

Standard Conditions, Constants, and Typical Values

Category	Value	Equivalent
Standard Temperature ¹	60 °F	520 °R
Universal Gas Constant	0.7302 atm-ft ³ /lb-mol ^o R	
Pressure ¹	1 atm	
Methane Heating Value ²	1,000 Btu/ft ³	
LFG Methane Component ⁸	45%	
LFG Typical Heating Value	454 Btu/ft ³	
LFG Temperature ³	100 °F	560 °R
LFG Moisture ²	8.0%	
Methane Combustion Constant ⁴	9.53 ft ³ air/ft ³ CH ₄	

Fuel & Equipment - Enclosed Flare

Flare Information	Value	Equivalent
No. of Hours of Operation Per Day ^b	24 hr	
No. of Days in Averaging Period ^d	730	
Operation Period Hours ³	16,902	
LFG inlet flow, standard ³	2,237 scfm	
LFG Inlet Flow, dry standard	2,058 dscfm	
Heat Input	61 MMBtu/hr	
Design Flare Operating Temperature ⁵	1,400 °F	1,860 °R
Excess Air for Combustion ⁵	230%	
Flare Tip Flow, standard	34,204 scfm	
Flare Tip Flow, actual	122,345 acfm	
Flare Tip Diameter ^{5,6}	10.0 ft	
Flare Tip Exhaust Velocity ⁶	1,558 ft/min	26.0 ft/s
Flare Tip Height, above local grade ^{5,6}	45 ft	

¹ Industrial STP (60°F, 30.00 in. Hg, 1 atm)

² Typical

³ Site Data

⁴ Professional Engineering Registration Program , 23-9.

⁵ Flare manufacturer

⁶ Used in air quality modeling

⁷ Typical LFG Range is 40-60%; on-site data supports 45%

⁸ Maximum possible operating period is based on two years. Actual operating hours in two year period from data provided by OLI

Criteria Pollutant Emissions - Enclosed Flare

Operation Period	16,902	hr
LFG inlet flow, standard	2,237	scfm
Heat Input	61	MMBtu/hr

SO₂ Emission Rate								
SO ₂ concentration in exhaust gas		5813	ppmv					
SO ₂ emission rate		131.6	lb/hr	1112.5	tpy			
						Individual Compound Contribution to SO₂		
						No. of S Atoms	S Conc (ppmv)	SO ₂ Emiss (lb/hr)
LFG Compound	CAS	MW (lb/lb-mol)	Conc (ppmv)¹	Control Eff^{1,2}				
Carbon Disulfide	75-15-0	76.13	0.58	100%		2	1.16	0.03
Carbonyl Sulfide	463-58-1	60.07	0.49	100%		1	0.49	0.01
Dimethyl Sulfide (methyl sulfide)	75-18-3	62.13	7.82	100%		1	7.82	0.18
Ethyl Mercaptan (ethanethiol)	75-08-1	62.13	1.25	100%		1	1.25	0.03
Hydrogen Sulfide ⁴	7783-06-4	34.08	5800	100%		1	5800.00	131.34
Methyl Mercaptan	74-93-1	48.11	2.49	100%		1	2.49	0.06
Total Contribution to SO ₂ :							5,813	132
PM₁₀ Emission Rate								
PM emission factor ¹		17	lb/MM dscf CH ₄					
PM emission rate		0.95	lb/hr	4.03	tpy			
NO₂ Emission Rate								
NO ₂ emission factor ³		0.06	lb/MMBtu					
NO ₂ emission rate		3.7	lb/hr	15.46	tpy			
CO Emission Rate								
CO emission factor ³		0.20	lb/MMBtu					
CO emission rate		12.2	lb/hr	51.54	tpy			
NMOC Emission Rate								
NMOC conc inlet gas ¹		595	ppmv					
MW hexane		86.18	lb/lb-mol					
destruction efficiency		98%						
mass NMOC inlet gas		18.1	lb/hr					
NMOC emission rate		0.36	lb/hr	1.53	tpy			
VOC Emission Rate								
NMOC conc inlet gas ¹		595	ppmv					
VOC fraction of NMOC ¹		39%						
VOC concentration in inlet gas		232	ppmv					
MW hexane		86.18	lb/lb-mol					
mass VOC inlet gas		7.1	lb/hr					
destruction efficiency		98%						
VOC emission rate		0.14	lb/hr	0.60	tpy			

¹ EPA, *Compilation of Air Pollutant Emission Factors, Volume I, Stationary Point and Area Sources, 5th Ed.* (November 1998).

² NPS required minimum control efficiency

³ LFG Specialties Inc. (typical)

⁴ The hydrogen sulfide concentration is site specific

Section II Appendix B Page 30/47
Application 1270-2

Emissions Calculations
003 Air Toxics Emissions

Okeechobee Landfill
Okeechobee, Florida

LFG inlet flow		2,237 scfm		Compound Conc & Mass		Control Eff ^{1,2}	Flare Exhaust	
LFG Compound	HAP	CAS	MW (lb/lb-mol)	in Inlet Gas (ppmv) ³	(lb/hr)		(lb/hr) ⁴	(tpy) ⁴
1,1,1 - Trichloroethane (methyl chloroform)	x	71-55-6	133.41	0.48	2.26E-02	98.0%	4.53E-04	1.91E-03
1,1,2,2 - Tetrachloroethane	x	79-34-5	167.85	1.11	6.59E-02	98.0%	1.32E-03	5.57E-03
1,1,2 - Trichloroethane (1,1,2 TCA)	x	79-00-5	133.41	0.10	4.72E-03	98.0%	9.43E-05	3.99E-04
1,1 - Dichloroethane (ethylidene dichloride)	x	75-34-3	98.96	2.35	8.22E-02	98.0%	1.64E-03	6.95E-03
1,1 - Dichloroethene (vinylidene chloride)	x	75-35-4	96.94	0.20	6.89E-03	98.0%	1.38E-04	5.82E-04
1,2 - Dichloroethane (ethylene dichloride)	x	107-06-2	98.96	0.41	1.42E-02	98.0%	2.85E-04	1.20E-03
1,2 - Dichloropropane (propylene dichloride)	x	78-87-5	112.99	0.18	7.19E-03	98.0%	1.44E-04	6.08E-04
2-Propanol (isopropyl alcohol)	--	67-63-0	60.11	50.1	1.06E+00	98.0%	2.13E-02	9.00E-02
Acetone (2-propanone)	--	67-64-1	58.08	7.01	1.44E-01	98.0%	2.88E-03	1.22E-02
Acrylonitrile (Propenenitrile)	x	107-13-1	53.06	6.33	1.19E-01	98.0%	2.37E-03	1.00E-02
Benzene	x	71-43-2	78.12	1.91	5.27E-02	98.0%	1.05E-03	4.46E-03
Bromodichloromethane	--	75-27-4	163.83	3.13	1.81E-01	98.0%	3.63E-03	1.53E-02
Butane	--	106-97-8	58.12	5.03	1.03E-01	98.0%	2.07E-03	8.73E-03
Carbon Disulfide	x	75-15-0	76.14	0.58	1.56E-02	98.0%	3.12E-04	1.32E-03
Carbon Tetrachloride	x	56-23-5	153.84	0.004	2.18E-04	98.0%	4.35E-06	1.84E-05
Carbonyl Sulfide	x	463-58-1	60.07	0.49	1.04E-02	98.0%	2.08E-04	8.79E-04
Chlorobenzene (monochlorobenzene)	x	108-90-7	112.56	0.25	1.01E-02	98.0%	2.02E-04	8.54E-04
Chlorodifluoromethane (CFC-22, freon-22)	--	75-45-6	86.47	1.30	3.97E-02	98.0%	7.95E-04	3.36E-03
Chloroethane (ethyl chloride)	x	75-00-3	64.52	1.25	2.85E-02	98.0%	5.70E-04	2.41E-03
Chloroform (trichloromethane)	x	67-66-3	119.38	0.03	1.27E-03	98.0%	2.53E-05	1.07E-04
Chloromethane (methyl chloride)	x	74-87-3	50.49	1.21	2.16E-02	98.0%	4.32E-04	1.82E-03
1,4 Dichlorobenzene (p-dichlorobenzene)	x	106-46-7	147	0.21	1.11E-02	98.0%	2.21E-04	9.35E-04
Dichlorodifluoromethane (CFC-12, freon-12)	--	75-71-8	120.91	15.7	6.71E-01	98.0%	1.34E-02	5.67E-02
Dichlorofluoromethane (freon-21)	--	75-43-4	102.92	2.62	9.53E-02	98.0%	1.91E-03	8.05E-03
Dichloromethane (methylene chloride)	x	75-09-2	84.93	14.3	4.29E-01	98.0%	8.59E-03	3.63E-02
Dimethyl Sulfide (methyl sulfide)	--	75-18-3	62.13	7.82	1.72E-01	98.0%	3.43E-03	1.45E-02
Ethane	--	74-84-0	30.07	889	9.45E+00	98.0%	1.89E-01	7.99E-01
Ethanol (ethyl alcohol)	--	64-17-5	46.08	27.2	4.43E-01	98.0%	8.86E-03	3.74E-02
Ethylbenzene	x	100-41-4	106.17	4.61	1.73E-01	98.0%	3.46E-03	1.46E-02
Ethyl Mercaptan (ethanethiol)	--	75-08-1	62.13	1.25	2.75E-02	98.0%	5.49E-04	2.32E-03
Ethylene dibromide (1,2 dibromoethane)	x	106-93-4	187.88	0.001	6.64E-05	98.0%	1.33E-06	5.61E-06
Fluorotrichloromethane (CFC-11, freon-11)	--	75-69-4	137.37	0.76	3.69E-02	98.0%	7.38E-04	3.12E-03
Hexane	x	110-54-3	86.18	6.57	2.00E-01	98.0%	4.00E-03	1.69E-02
Hydrogen Sulfide ^{5,6}	--	7783-06-4	34.08	5800	6.99E+01	99.9%	6.99E-02	2.95E-01
Mercury (total)	x	7439-97-6	200.61	2.92E-04	2.07E-05	0.0%	2.07E-05	8.75E-05
Methyl Ethyl Ketone (2-butanone)	--	78-93-3	72.11	7.09	1.81E-01	98.0%	3.61E-03	1.53E-02
Methyl Isobutyl Ketone (hexone)	x	108-10-1	100.16	1.87	6.62E-02	98.0%	1.32E-03	5.59E-03
Methyl Mercaptan	--	74-93-1	48.11	2.49	4.23E-02	98.0%	8.47E-04	3.58E-03
Pentane	--	109-66-0	72.15	3.29	8.39E-02	98.0%	1.68E-03	7.09E-03
Tetrachloroethylene (perchloroethylene, -ethene)	x	127-18-4	165.83	3.73	2.19E-01	98.0%	4.37E-03	1.85E-02
Propane	--	74-98-6	44.1	11.1	1.73E-01	98.0%	3.46E-03	1.46E-02
Toluene (methylbenzene)	x	108-88-3	92.14	39.3	1.28E+00	98.0%	2.56E-02	1.08E-01
Trichloroethylene (trichloroethene)	x	79-01-6	131.38	2.82	1.31E-01	98.0%	2.62E-03	1.11E-02
t - 1,2 - Dichloroethene (1,2 dichloroethylene)	--	156-60-5	96.94	2.84	9.73E-02	98.0%	1.95E-03	8.22E-03
Vinyl Chloride (chloroethylene, VCM)	x	75-01-4	62.50	7.34	1.62E-01	98.0%	3.24E-03	1.37E-02
Xylenes (m, o, p)	x	1330-20-7	106.17	12.1	4.54E-01	98.0%	9.08E-03	3.84E-02
Hydrogen Chloride	x	7647-01-0	36.50	42.0	5.42E-01	0.0%	5.42E-01	2.29E+00
Total HAP							0.61	2.59
Maximum Single HAP							0.54	2.29
Hydrogen Sulfide							0.07	0.30

¹ EPA, *Compilation of Air Pollutant Emission Factors, Volume 1 Stationary Point and Area Sources, 5th Ed.* (November 1998)

² NSPS required minimum control efficiency

³ Product of combustion

⁴ Because HCl is a production of combustion, a default outlet concentration is listed; AP-42, Section 2.4.4

⁵ The hydrogen sulfide concentration is site specific

⁶

Control Efficiency based on various references including, Canadian Centre for Occupational Health and Safety: CCOHS Chemical Name hydrogen Sulfide, October 3, 2005

EU005 3,000-scfm enclosed flare w/evap
Unit #2 - summary of Field Collected Data
Flare Operation - June 2004 - June 2006

Month	Operational (hours)	Downtime (hours)	Total (hours)	Average CH4 (%)	Average Flow (scfm) To Flare	Average Flow (scfm) To EVAP	Average Flow (scfm) Total
July	740.47	3.53	744	54.1	1,610	329	1,939
August	742.5	1.5	744	55.5	1,756	280	2,036
September	604.5	115.5	720	51.7	1,576	375	1,951
October	737.83	6.17	744	52.9	1,511	382	1,893
November	717.92	2.08	720	52.0	1,517	379	1,896
December	690.32	53.68	744	52.4	2,006	219	2,225
January (05)	743.72	0.28	744	48.5	1,425	357	1,782
February	671.75	0.25	672	51.7	1,741	364	2,105
March	741.5	2.5	744	48.7	1,692	380	2,072
April	718.67	1.33	720	48.9	1,570	366	1,936
May	744	0	744	47.7	1,513	382	1,895
June	714.4	5.6	720	44.6	1,576	366	1,942
July	744	0	744	50.2	1,561	325	1,886
August	740.1	3.9	744	50.4	1,716	327	2,043
September	720	0	720	45.4	1,708	350	2,058
October	739.77	4.23	744	41.9	1,786	360	2,146
November	717.43	2.57	720	40.5	1,621	322	1,943
December	742.18	1.82	744	42.7	2,168	327	2,495
January (06)	741.58	2.42	744	45.4	2359	312	2671
February	671.18	0.82	672	43.4	2452	324	2776
March	742.6	1.4	744	41.7	2467	324	2791
April	719.63	0.37	720	39.6	2333	334	2667
May	742.9	1.1	744	38.0	2088	322	2410
June	546.13	173.87	720	38.6	2190	323	2513
July	719.47	24.30	744	47.7	2547	253	2800
August	727.98	16.02	744	41.8	1716	320	2036
September	717.23	2.77	720	47.1	1851	322	2174
October	744.00	0.00	744	44.5	1976	336	2312
November	700.17	19.83	720	46.4	1879	249	2128
December	719.23	24.77	744	43.7	1639	420	2059
January (07)	682.22	61.78	744	40.4	1622	435	2057
Highest 24-Month Total/ AVERAGES:	17168	352	17520	46.9	1831	339	2246

Standard Conditions, Constants, and Typical Values

Category	Value	Equivalent
Standard Temperature ¹	60 °F	520 °R
Universal Gas Constant	0.7302 atm-ft ³ /lb-mol°R	
Pressure ¹	1 atm	
Methane Heating Value ²	1,000 Btu/ft ³	
LFG Methane Component ⁸	45%	
LFG Typical Heating Value	454 Btu/ft ³	
LFG Temperature ³	100 °F	560 °R
LFG Moisture ²	8.0%	
Methane Combustion Constant ⁴	9.53 ft ³ air/ft ³ CH ₄	

Fuel & Equipment - Enclosed Flare

Flare Information	Value	Equivalent
No. of Hours of Operation Per Day ⁹	24 hr	
No. of Days in Averaging Period ⁹	730	
Operation Period ⁹	17,168	
LFG inlet flow, standard ³	2,246 scfm	
LFG Inlet Flow, dry standard	2,067 dscfm	
Heat Input	61 MMBtu/hr	
Design Flare Operating Temperature ^{5,7}	1,400 °F	1,860 °R
Excess Air for Combustion ⁶	230%	
Flare Tip Flow, standard	34,350 scfm	
Flare Tip Flow, actual	122,869 acfm	
Flare Tip Diameter ^{5,7}	10.0 ft	
Flare Tip Exhaust Velocity ⁷	1,564 ft/min	26.1 ft/s
Flare Tip Height, above local grade ^{5,7}	45 ft	

¹ Industrial STP (60°F, 30.00 in. Hg, 1 atm)

² Typical

³ Site Data

⁴ *Professional Engineering Registration Program*, 23-9.

⁵ Flare manufacturer

⁶ Used in air quality modeling

⁷ Typical LFG Range is 40-60%; on-site data supports 45%

⁸ Maximum possible operating period is based on two years. Actual operating hours in two year period from data provided by OLI

Criteria Pollutant Emissions - Enclosed Flare

Operation Period	17,168	hr
LFG inlet flow, standard	2,246	scfm
Heat Input	61	MMBtu/hr

SO₂ Emission Rate								
SO ₂ concentration in exhaust gas		5807	ppmv					
SO ₂ emission rate		132.1	lb/hr	1133.7	tpy			
LFG Compound	CAS	MW (lb/lb-mol)	Conc (ppmv) ¹	Control Eff ^{1,2}	Individual Compound Contribution to SO ₂			
					No. of S Atoms	S Conc (ppmv)	SO ₂ Emiss (lb/hr)	
Carbon Disulfide	75-15-0	76.13	0.58	100%	2	1.16	0.03	
Carbonyl Sulfide	463-58-1	60.07	0.49	100%	1	0.49	0.01	
Dimethyl Sulfide (methyl sulfide)	75-18-3	62.13	7.82	100%	1	7.81	0.18	
Ethyl Mercaptan (ethanethiol)	75-08-1	62.13	1.25	100%	1	1.25	0.03	
Hydrogen Sulfide ⁴	7783-06-4	34.08	5800	100%	1	5794.20	131.77	
Methyl Mercaptan	74-93-1	48.11	2.49	100%	1	2.49	0.06	
Total Contribution to SO ₂ :						5,807	132	
PM₁₀ Emission Rate								
PM emission factor ¹		17	lb/MM dscf CH ₄					
PM emission rate		0.96	lb/hr	4.11	tpy			
NO₂ Emission Rate								
NO ₂ emission factor ³		0.06	lb/MMBtu					
NO ₂ emission rate		3.7	lb/hr	15.77	tpy			
CO Emission Rate								
CO emission factor ³		0.20	lb/MMBtu					
CO emission rate		12.2	lb/hr	52.58	tpy			
NMOC Emission Rate								
NMOC conc inlet gas ¹		595	ppmv					
MW hexane		86.18	lb/lb-mol					
destruction efficiency		98%						
mass NMOC inlet gas		18.2	lb/hr					
NMOC emission rate		0.36	lb/hr	1.56	tpy			
VOC Emission Rate								
NMOC conc inlet gas ¹		595	ppmv					
VOC fraction of NMOC ¹		39%						
VOC concentration in inlet gas		232	ppmv					
MW hexane		86.18	lb/lb-mol					
mass VOC inlet gas		7.1	lb/hr					
destruction efficiency		98%						
VOC emission rate		0.14	lb/hr	0.61	tpy			

¹ EPA, *Compilation of Air Pollutant Emission Factors, Volume I. Stationary Point and Area Sources, 5th Ed.* (November 1998).

² NSPS required minimum control efficiency

³ Flare manufacturer data. (typical)

⁴ The hydrogen sulfide concentration is site specific

Section II Appendix B Page 34/47
Application 1270-2

Emissions Calculations
005 Air Toxics Emissions

Okeechobee Landfill
Okeechobee, Florida

LFG inlet flow

2,248 scfm

LFG Compound	HAP	CAS	MW (lb/lb-mol)	Compound Conc & Mass in Inlet Gas		Control Eff ^{1,2}	Flare Exhaust	
				(ppmv) ³	(lb/hr)		(lb/hr)*	(tpy)*
1,1,1 - Trichloroethane (methyl chloroform)	x	71-55-6	133.41	0.48	2.27E-02	98.0%	4.55E-04	1.95E-03
1,1,2,2 - Tetrachloroethane	x	79-34-5	167.85	1.11	6.61E-02	98.0%	1.32E-03	5.68E-03
1,1,2 - Trichloroethane (1,1,2 TCA)	x	79-00-5	133.41	0.10	4.74E-03	98.0%	9.47E-05	4.07E-04
1,1 - Dichloroethane (ethylidene dichloride)	x	75-34-3	98.96	2.35	8.26E-02	98.0%	1.65E-03	7.09E-03
1,1 - Dichloroethene (vinylidene chloride)	x	75-35-4	96.94	0.20	6.92E-03	98.0%	1.38E-04	5.94E-04
1,2 - Dichloroethane (ethylene dichloride)	x	107-06-2	98.96	0.41	1.43E-02	98.0%	2.86E-04	1.23E-03
1,2 - Dichloropropane (propylene dichloride)	x	78-87-5	112.99	0.18	7.22E-03	98.0%	1.44E-04	6.20E-04
2-Propanol (isopropyl alcohol)	--	67-63-0	60.11	50.1	1.07E+00	98.0%	2.14E-02	9.18E-02
Acetone (2-propanone)	--	67-64-1	58.08	7.01	1.45E-01	98.0%	2.89E-03	1.24E-02
Acrylonitrile (Propenenitrile)	x	107-13-1	53.06	6.33	1.19E-01	98.0%	2.38E-03	1.02E-02
Benzene	x	71-43-2	78.12	1.91	5.30E-02	98.0%	1.06E-03	4.55E-03
Bromodichloromethane	--	75-27-4	163.83	3.13	1.82E-01	98.0%	3.64E-03	1.56E-02
Butane	--	106-97-8	58.12	5.03	1.04E-01	98.0%	2.08E-03	8.91E-03
Carbon Disulfide	x	75-15-0	76.14	0.58	1.57E-02	98.0%	3.14E-04	1.35E-03
Carbon Tetrachloride	x	56-23-5	153.84	0.004	2.18E-04	98.0%	4.37E-06	1.88E-05
Carbonyl Sulfide	x	463-58-1	60.07	0.49	1.04E-02	98.0%	2.09E-04	8.97E-04
Chlorobenzene (monochlorobenzene)	x	108-90-7	112.56	0.25	1.01E-02	98.0%	2.03E-04	8.71E-04
Chlorodifluoromethane (CFC-22, freon-22)	--	75-45-6	86.47	1.30	3.99E-02	98.0%	7.98E-04	3.43E-03
Chloroethane (ethyl chloride)	x	75-00-3	64.52	1.25	2.86E-02	98.0%	5.73E-04	2.46E-03
Chloroform (trichloromethane)	x	67-66-3	119.38	0.03	1.27E-03	98.0%	2.54E-05	1.09E-04
Chloromethane (methyl chloride)	x	74-87-3	50.49	1.21	2.17E-02	98.0%	4.34E-04	1.86E-03
1,4 Dichlorobenzene (p-dichlorobenzene)	x	106-46-7	147	0.21	1.11E-02	98.0%	2.22E-04	9.54E-04
Dichlorodifluoromethane (CFC-12, freon-12)	--	75-71-8	120.91	15.7	6.74E-01	98.0%	1.35E-02	5.78E-02
Dichlorofluoromethane (freon-21)	--	75-43-4	102.92	2.62	9.57E-02	98.0%	1.91E-03	8.22E-03
Dichloromethane (methylene chloride)	x	75-09-2	84.93	14.3	4.31E-01	98.0%	8.62E-03	3.70E-02
Dimethyl Sulfide (methyl sulfide)	--	75-18-3	62.13	7.82	1.72E-01	98.0%	3.45E-03	1.48E-02
Ethane	--	74-84-0	30.07	889	9.49E+00	98.0%	1.90E-01	8.15E-01
Ethanol (ethyl alcohol)	--	64-17-5	46.08	27.2	4.45E-01	98.0%	8.90E-03	3.82E-02
Ethylbenzene	x	100-41-4	106.17	4.61	1.74E-01	98.0%	3.47E-03	1.49E-02
Ethyl Mercaptan (ethanethiol)	--	75-08-1	62.13	1.25	2.76E-02	98.0%	5.51E-04	2.37E-03
Ethylene dibromide (1,2 dibromoethane)	x	106-93-4	187.88	0.001	6.67E-05	98.0%	1.33E-06	5.73E-06
Fluorotrichloromethane (CFC-11, freon-11)	--	75-69-4	137.37	0.76	3.71E-02	98.0%	7.41E-04	3.18E-03
Hexane	x	110-54-3	86.18	6.57	2.01E-01	98.0%	4.02E-03	1.73E-02
Hydrogen Sulfide ^{5,6}	--	7783-06-4	34.08	5800	7.02E+01	99.9%	7.02E-02	3.01E-01
Mercury (total)	x	7439-97-6	200.61	2.92E-04	2.08E-05	0.0%	2.08E-05	8.92E-05
Methyl Ethyl Ketone (2-butanone)	--	78-93-3	72.11	7.09	1.81E-01	98.0%	3.63E-03	1.56E-02
Methyl Isobutyl Ketone (hexone)	x	108-10-1	100.16	1.87	6.65E-02	98.0%	1.33E-03	5.71E-03
Methyl Mercaptan	--	74-93-1	48.11	2.49	4.25E-02	98.0%	8.50E-04	3.65E-03
Pentane	--	109-66-0	72.15	3.29	8.43E-02	98.0%	1.69E-03	7.23E-03
Tetrachloroethylene (perchloroethylene, -ethene)	x	127-18-4	165.83	3.73	2.20E-01	98.0%	4.39E-03	1.88E-02
Propane	--	74-98-6	44.1	11.1	1.74E-01	98.0%	3.48E-03	1.49E-02
Toluene (methylbenzene)	x	108-88-3	92.14	39.3	1.29E+00	98.0%	2.57E-02	1.10E-01
Trichloroethylene (trichloroethene)	x	79-01-6	131.38	2.82	1.32E-01	98.0%	2.63E-03	1.13E-02
1,2 - Dichloroethene (1,2 dichloroethylene)	--	156-60-5	96.94	2.84	9.77E-02	98.0%	1.95E-03	8.39E-03
Vinyl Chloride (chloroethylene, VCM)	x	75-01-4	62.50	7.34	1.63E-01	98.0%	3.26E-03	1.40E-02
Xylenes (m, o, p)	x	1330-20-7	106.17	12.1	4.56E-01	98.0%	9.12E-03	3.91E-02
Hydrogen Chloride	x	7647-01-0	36.50	42.0	5.44E-01	0.0%	5.44E-01	2.34E+00
Total HAP							0.62	2.65
Maximum Single HAP							0.54	2.34
Hydrogen Sulfide							0.07	0.30

¹ EPA, *Compilation of Air Pollutant Emission Factors, Volume I, Stationary Point and Area Sources, 5th Ed.* (November 1996)

² NSPS required minimum control efficiency

³ Product of combustion

⁴ Because HCl is a production of combustion, a default output concentration is listed, AP-42, Section 2.4.4.

⁵ The hydrogen sulfide concentration is site specific

⁶

Control Efficiency based on various references including: Canadian Centre for Occupational Health and Safety: CCOHS Chemical Name hydrogen Sulfide, October 3, 2005

Letter Symbol	Definition
acfm	actual cubic foot per minute
atm	atmosphere
atm-ft ³ /lb-mol ^o R	atmosphere cubic foot per pound mole degree Rankine
bhp	brake horsepower
Btu	british thermal unit
cal/s	calorie per second
CH ₄	methane
CO	carbon monoxide
d	day
dscfm	dry standard cubic foot, feet per minute
dsl/min	dry standard litre per minute
ft	foot
ft/min	foot per minute
ft/s	foot per second
ft ³	cubic foot
g	gram
HAP	hazardous air pollutant
Hg	mercury
HHV	higher heating value
hr	hour
HV	heating value
in.	inch
kW	kilowatt
kWh	kilowatt hour
l	litre
lb/hr	pound per hour
LHV	lower heating value
m	meter
m/s	meter per second
m ³	cubic meter
μg	microgram
mg	milligram
μg/dsl	microgram per dry standard litre
min	minute
MM	million
MMBtu	million british thermal units
mol	mole
NMOC	non-methane organic compounds
NO ₂	nitrogen dioxide
Nox	nitrogen oxides
°F	degree Fahrenheit
R	Rankine
Pb	lead
PM ₁₀	particulate matter less than or equal to 10 microns
ppmv	parts per million by volume
ppmw	parts per million by weight
R	universal gas constant
s	second
scf	standard cubic foot
scfm	standard cubic foot per minute
SO ₂	sulfur dioxide
STP	standard temperature and pressure
ton	ton
tpy	ton per year
VOC	volatile organic compound

Emissions Calculations
Sample Calculations

Okeechobee Landfill
Okeechobee, Florida

Sample Calculations

Standard Conditions and Constants

$$^{\circ}\text{R} = ^{\circ}\text{F} + 460$$

standard temperature = 60 °F

standard pressure = 1 atm

Universal gas constant (R) = 0.7302 atm-ft³/lb-mol^oR

Flow

$$\text{dscfm} = \text{scfm} * (1 - \% \text{moisture})$$

$$\text{acfm} = \text{scfm} * (\text{actual temp}[^{\circ}\text{R}]) / (\text{standard temp}[^{\circ}\text{R}]) * (\text{standard press}[\text{atm}] / (\text{actual press} [\text{atm}]})$$

CO and NO_x Emissions

$$(\text{lb/MMbtu}) * (\text{MMbtu/hr}) = \text{lb/hr}$$

SO₂ Emissions

typically, 86% to 99.7% of sulfur compounds convert to SO₂ during combustion

$$\{(\text{scfm}) * (60 \text{ min/hr}) * (\text{total sulfur concentration} [\text{ppmv}]) * (1 - \text{control efficiency}) * (\text{MW SO}_2)\} / \{(R) * (T)\} = \text{lb/hr}$$

PM₁₀ Emissions

$$(\text{dscfm}) * (\text{CH}_4 \text{ component}) * (1\text{E-}6 \text{ MMscf/scf}) * (\text{lb PM/MMscf CH}_4) * (60 \text{ min/hr}) = \text{lb/hr}$$

VOC Emissions

$$\{(\text{scfm} * 60 \text{ min/hr} * \text{concentration}_{\text{compound}} [\text{ppmv}] * \text{MW}_{\text{compound}})\} / \{(R) * (T)\} * (1 - \text{control efficiency}) = \text{lb/hr}$$

OR

VOCs are 39 percent of NMOC, as prescribed in AP-42

$$\text{VOC concentration} [\text{ppmv}] = \text{NMOC concentration} [\text{as hexane}] * 39\%$$

flare and/or engines typically combust 98% of VOCs

$$\{(\text{scfm} * 60 \text{ min/hr} * \text{concentration}_{\text{hexane}} [\text{ppmv}] * \text{MW}_{\text{hexane}})\} / \{(R) * (T)\} * (0.39) = \text{lb/hr}$$

LFG Compound Emissions

$$\{(\text{scfm} * 60 \text{ min/hr} * \text{concentration}_{\text{compound}} [\text{ppmv}] * \text{MW}_{\text{compound}})\} / \{(R) * (T)\} * (1 - \text{control efficiency})$$

HCl Emissions

typically, 86% to 99.7% of chlorine compounds convert to HCl during combustion

(concentration_{compound} [ppm]) * (control efficiency) * (no. of chlorine atoms) = HCl concentration [ppm] in outlet gas from each comp

$$\{\text{HCl concentration}_{\text{each compound}} [\text{ppm}] * \text{scfm} * \text{MW}_{\text{HCl}}\} / \{(R) * (T)\} * (60 \text{ min/hr}) = \text{lb/hr}$$

OR

$$\{(\text{scfm}) * (60 \text{ min/hr}) * (\text{HCl outlet concentration per AP-42} [\text{ppmv}]) * (1 - \text{control efficiency}) * (\text{MW})\} / \{(R) * (T)\} = \text{lb/hr}$$

EU-001 MSW Landfill - BASELINE ACTUAL EMISSIONS

24-month period for all pollutants =

Utility Flares: Utility Flare (Backup) and Odor Control Flare

Description	LFG Flow (scfm)	24-month period Hours of Operation	Units	Calculated Emissions								
				NO ₂	CO	SO ₂	PM ₁₀	NMOC	VOC	Total HAPs	Single HAP	H ₂ S
Utility Flare (Backup)	2,240	847	lb/hr	4.57	24.9	132	1.06	0.37	0.15	0.61	0.54	0.08
			tpy	1.0	5.3	56	0.22	0.08	0.03	0.13	0.11	0.02
Utility Flare - Odor Control ¹	764	5,150	lb/hr	1.56	8.5	45	0.36	0.13	0.05	0.21	0.19	0.03
			tpy	2.0	10.9	116	0.46	0.17	0.06	0.27	0.24	0.04
Total Open Flares			lb/hr	6.13	33.36	176.90	1.42	0.50	0.20	0.82	0.73	0.11
			tpy	2.98	16.19	171.71	0.69	0.25	0.10	0.40	0.35	0.06

¹ The odor control flare has been operating since July 01, 2006. The 24-month period must consider the non-operating months as zero.

**EU004 3,000-scfm Backup Utility Flare
 Summary of Field Collected Data
 Flare Operation - June 2004 - January 2007**

Month	Operational (hours)	Average Flow (scfm) Total from Shutdown
July	3.53	2,034
August	13.78	2,099
September	115.50	1,974
October	19.33	1,926
November	10.50	1,874
December	53.68	1,874
January (05)	4.65	1,667
February	2.42	2,001
March	3.92	1,986
April	1.33	1,904
May	8.87	1,888
June	9.50	1,890
July	3.65	1,862
August	9.68	1,976
September	10.27	2,127
October	73.55	2,305
November	3.75	2,036
December	5.43	2,316
January (06)	5.65	2,494
February	4.57	2,567
March	6.75	2,553
April	149.60	2,658
May	5.78	2,581
June	173.87	2,711
July	24.30	2,625
August	87.58	2,361
September	6.5	2,262
October	167.9	2,298
November	16.9	2,128
December	18.1	2,116
January (07)	46.7	2,115
TOTALS / 24-month high AVERAGES:	846.6	2240

1 Operating data not available; the backup utility flare's operating time is based on the downtime of the enclosed flares. Flow rate is based on the average of the two enclosed flares.

Standard Conditions, Constants, and Typical Values

Category	Value	Equivalent
Standard Temperature ¹	60 °F	519.7 °R
Universal Gas Constant	0.7302 atm-ft ³ /lb-mol-°R	
Pressure ¹	1 atm	
Methane Heating Value ²	1,000 Btu/ft ³	
LFG Methane Component ³	50%	
LFG Typical Heating Value	500 Btu/ft ³	
LFG Temperature ³	100 °F	559.7 °R
LFG Moisture ³	8.0%	

Fuel & Equipment - Open Flare

Flare Information	Value	Equivalent
No. of Hours of Operation Per Day ³		hr
No. of Days in Averaging Period ²		day
Operation Period ²	847	hr
LFG inlet flow, standard ⁴	2,240	scfm
LFG Inlet Flow, dry standard	2,061	dscfm
Heat Input	67.2	MMBtu/hr
Design Flare Operating Temperature ⁴	1,400 °F	1,859.7 °R
Flare Tip Flow, standard	2,240	scfm
Flare Tip Flow, actual	2,412	acfm
Flare Tip Diameter ⁴	1.00	ft
Flare Tip Exhaust Velocity	3,071	ft/min
Flare Heat release (gross) ⁵	4,703,537	cal/s
Flare Heat release (net) ⁵	3,465,297	
Flare Tip Height, above local grade ^{4,5}	35	ft
Effective Exhaust Velocity ^{5,6}	20.0	m/s
Effective Exhaust Temperature ^{5,6}	1,273	K
Effective Exhaust Diameter ^{5,6,7}	1.86	m
		35 ft
		65.6 ft/s
		1,832 °F
		6.11 ft

¹ Industrial STP (60°F, 30.00 in. Hg, 1 atm);

² Typical

³ Derived site test data

⁴ Flare manufacturer

⁵ TCEQ, Interoffice Memorandum, *Technical Basis for Flare Parameters*, (September 10, 2004)

⁶ Used in air modeling

⁷ Based on a landfill gas molecular weight of 30.03

⁸ Average of 3 stack tests

Emissions Calculations
Open Flares

Okeechobee Landfill
Okeechobee, Fla.

Criteria Pollutant Emissions - Open Flare

Operation Period	847 hr
LFG inlet flow, standard	2,240 scfm
Heat Input	67 MMBtu/hr

SO₂ Emission Rate								
SO ₂ concentration in exhaust gas		5813.2 ppmv						
SO ₂ emission rate		131.9 lb/hr		56 tpy				
LFG Compound	CAS	MW (lb/lb-mol)	Conc (ppmv) ¹	Control Eff ^{1,2}	Individual Compound Contribution to SO ₂			
					No. of S Atoms	S Conc (ppmv)	SO ₂ Emiss (lb/hr)	
Carbon Disulfide	75-15-0	76.13	0.58	100%	2	1.16	2.6E-02	
Carbonyl Sulfide	463-58-1	60.07	0.49	100%	1	0.49	1.1E-02	
Dimethyl Sulfide (methyl sulfide)	75-18-3	62.13	7.82	100%	1	7.82	1.8E-01	
Ethyl Mercaptan (ethanethiol)	75-08-1	62.13	1.25	100%	1	1.25	2.8E-02	
Hydrogen Sulfide	7783-06-4	34.08	5800.0	100%	1	5800	1.3E+02	
Methyl Mercaptan	74-93-1	48.11	2.49	100%	1	2.49	5.6E-02	
Total Contribution to SO ₂ :						5813	132	
PM₁₀ Emission Rate								
PM emission factor ²		17 lb/MM dscf CH ₄						
PM emission rate		1.06 lb/hr		0.22 tpy				
NO₂ Emission Rate								
NO ₂ emission factor ²		0.068 lb/MMBtu						
NO ₂ emission rate		4.57 lb/hr		1.0 tpy				
CO Emission Rate								
CO emission factor ²		0.37 lb/MMBtu						
CO emission rate		24.9 lb/hr		5.3 tpy				
NMOC Emission Rate								
NMOC conc inlet gas ¹		595 ppmv						
MW hexane		86.18 lb/lb-mol						
destruction efficiency		98%						
mass NMOC inlet gas		18.16 lb/hr						
NMOC emission rate		0.37 lb/hr		0.08 tpy				
VOC Emission Rate								
NMOC conc inlet gas ¹		595 ppmv						
VOC fraction of NMOC ¹		39%						
VOC concentration in inlet gas		232 ppmv						
MW hexane		86.18 lb/lb-mol						
mass VOC inlet gas		7.08 lb/hr						
destruction efficiency		98%						
VOC emission rate		0.15 lb/hr		0.03 tpy				

¹ EPA, *Compilation of Air Pollutant Emission Factors, Volume I. Stationary Point and Area Sources, 5th Ed.* (November 1998).

² NSPS minimum required control efficiency

Section II Appendix B Page 41/47
Application 1270-2

Emissions Calculations
Open Flares

Okeechobee Landfill
Okeechobee, Fla.

Air Toxics Emissions from Open Flare		The flare's inlet fld		2,240		scfm			
LFG Compound	HAP	CAS	MW (lb/lb-mol)	Compound Conc & Mass in Inlet Gas		Control Eff ^{1,2}	Flare Exhaust		
				(ppmv) ³	(lb/hr)		(lb/hr)*	(tpy)*	
1,1,1 - Trichloroethane (methyl chloroform)	x	71-55-6	133.41	0.48	2.27E-02	98.0%	4.54E-04	9.60E-05	
1,1,2,2 - Tetrachloroethane	x	79-34-5	167.85	1.11	6.60E-02	98.0%	1.32E-03	2.79E-04	
1,1,2 - Trichloroethane (1,1,2 TCA)	x	79-00-5	133.41	0.10	4.72E-03	98.0%	9.45E-05	2.00E-05	
1,1 - Dichloroethane (ethylidene dichloride)	x	75-34-3	98.96	2.35	8.24E-02	98.0%	1.65E-03	3.49E-04	
1,1 - Dichloroethene (vinylidene chloride)	x	75-35-4	96.94	0.20	6.90E-03	98.0%	1.38E-04	2.92E-05	
1,2 - Dichloroethane (ethylene dichloride)	x	107-06-2	98.96	0.41	1.43E-02	98.0%	2.85E-04	6.04E-05	
1,2 - Dichloropropane (propylene dichloride)	x	78-87-5	112.99	0.18	7.20E-03	98.0%	1.44E-04	3.05E-05	
2-Propanol (isopropyl alcohol)	--	67-63-0	60.11	50.1	1.07E+00	98.0%	2.13E-02	4.51E-03	
Acetone (2-propanone)	--	67-64-1	58.08	7.01	1.44E-01	98.0%	2.88E-03	6.10E-04	
Acrylonitrile (Propenenitrile)	x	107-13-1	53.06	6.33	1.19E-01	98.0%	2.38E-03	5.04E-04	
Benzene	x	71-43-2	78.12	1.91	5.28E-02	98.0%	1.06E-03	2.24E-04	
Bromodichloromethane	--	75-27-4	163.83	3.13	1.82E-01	98.0%	3.63E-03	7.69E-04	
Butane	--	106-97-8	58.12	5.03	1.04E-01	98.0%	2.07E-03	4.38E-04	
Carbon Disulfide	x	75-15-0	76.14	0.58	1.56E-02	98.0%	3.13E-04	6.62E-05	
Carbon Tetrachloride	x	56-23-5	153.84	0.004	2.18E-04	98.0%	4.36E-06	9.23E-07	
Carbonyl Sulfide	x	463-58-1	60.07	0.49	1.04E-02	98.0%	2.08E-04	4.41E-05	
Chlorobenzene (monochlorobenzene)	x	108-90-7	112.56	0.25	1.01E-02	98.0%	2.03E-04	4.29E-05	
Chlorodifluoromethane (CFC-22, freon-22)	--	75-45-6	86.47	1.30	3.98E-02	98.0%	7.96E-04	1.69E-04	
Chloroethane (ethyl chloride)	x	75-00-3	64.52	1.25	2.86E-02	98.0%	5.71E-04	1.21E-04	
Chloroform (trichloromethane)	x	67-66-3	119.38	0.03	1.27E-03	98.0%	2.54E-05	5.37E-06	
Chloromethane (methyl chloride)	x	74-87-3	50.49	1.21	2.16E-02	98.0%	4.33E-04	9.16E-05	
1,4 Dichlorobenzene (p-dichlorobenzene)	x	106-46-7	147	0.21	1.11E-02	98.0%	2.22E-04	4.69E-05	
Dichlorodifluoromethane (CFC-12, freon-12)	--	75-71-8	120.91	15.7	6.72E-01	98.0%	1.34E-02	2.85E-03	
Dichlorofluoromethane (freon-21)	--	75-43-4	102.92	2.62	9.55E-02	98.0%	1.91E-03	4.04E-04	
Dichloromethane (methylene chloride)	x	75-09-2	84.93	14.3	4.30E-01	98.0%	8.60E-03	1.82E-03	
Dimethyl Sulfide (methyl sulfide)	--	75-18-3	62.13	7.82	1.72E-01	98.0%	3.44E-03	7.28E-04	
Ethane	--	74-84-0	30.07	889	9.47E+00	98.0%	1.89E-01	4.01E-02	
Ethanol (ethyl alcohol)	--	64-17-5	46.08	27.2	4.44E-01	98.0%	8.88E-03	1.88E-03	
Ethylbenzene	x	100-41-4	106.17	4.61	1.73E-01	98.0%	3.47E-03	7.34E-04	
Ethyl Mercaptan (ethanethiol)	--	75-08-1	62.13	1.25	2.75E-02	98.0%	5.50E-04	1.16E-04	
Ethylene dibromide (1,2 dibromoethane)	x	106-93-4	187.88	0.001	6.65E-05	98.0%	1.33E-06	2.82E-07	
Fluorotrichloromethane (CFC-11, freon-11)	--	75-69-4	137.37	0.76	3.70E-02	98.0%	7.39E-04	1.57E-04	
Hexane	x	110-54-3	86.18	6.57	2.01E-01	98.0%	4.01E-03	8.49E-04	
Hydrogen Sulfide ⁵	--	7783-06-4	34.08	5800	7.00E+01	99.9%	7.00E-02	1.48E-02	
Mercury (total)	x	7439-97-6	200.61	2.92E-04	2.07E-05	0.0%	2.07E-05	4.39E-06	
Methyl Ethyl Ketone (2-butanone)	--	78-93-3	72.11	7.09	1.81E-01	98.0%	3.62E-03	7.66E-04	
Methyl Isobutyl Ketone (hexone)	x	108-10-1	100.16	1.87	6.63E-02	98.0%	1.33E-03	2.81E-04	
Methyl Mercaptan	--	74-93-1	48.11	2.49	4.24E-02	98.0%	8.48E-04	1.80E-04	
Pentane	--	109-66-0	72.15	3.29	8.41E-02	98.0%	1.68E-03	3.56E-04	
Tetrachloroethylene (perchloroethylene, -ethene)	x	127-18-4	165.83	3.73	2.19E-01	98.0%	4.38E-03	9.27E-04	
Propane	--	74-98-6	44.1	11.1	1.73E-01	98.0%	3.47E-03	7.34E-04	
Toluene (methylbenzene)	x	108-88-3	92.14	39.3	1.28E+00	98.0%	2.56E-02	5.43E-03	
Trichloroethylene (trichloroethene)	x	79-01-6	131.38	2.82	1.31E-01	98.0%	2.62E-03	5.55E-04	
t - 1,2 - Dichloroethene (1,2 dichloroethylene)	--	156-60-5	96.94	2.84	9.75E-02	98.0%	1.95E-03	4.13E-04	
Vinyl Chloride (chloroethylene, VCM)	x	75-01-4	62.50	7.34	1.62E-01	98.0%	3.25E-03	6.88E-04	
Xylenes (m, o, p)	x	1330-20-7	106.17	12.1	4.55E-01	98.0%	9.10E-03	1.93E-03	
Hydrogen Chloride ^{3,4}	x	7647-01-0	36.50	42.0	5.43E-01	0.0%	5.43E-01	1.15E-01	
Total HAP							0.61	1.30E-01	
Maximum Single HAP							0.54	0.11	
Hydrogen Sulfide ⁵							0.08	0.02	
Hydrogen Sulfide - WITH BACT	--	7783-06-4	34.08	250	3.02E+00	98.0%	0.060	0.03	

¹ EPA, *Compilation of Air Pollutant Emission Factors, Volume I: Stationary Point and Area Sources*, 5th Ed. (November 1998)

² NSPS minimum required control efficiency

³ Product of combustion

⁴ Because HCl is a product of combustion, a default outlet concentration is listed; AP-42, Section 2.4.4

⁵ Control Efficiency based on various references including, Canadian Centre for Occupational Health and Safety, CCOHS Chemical Name hydrogen Sulfide; October 3, 2005

Odor Control Flare 3,000-scfm Backup Utility Flare
Summary of Field Collected Data
Flare Operation - June 2004 - January 2007

Month	Operational (hours)	Flowrate (cfm)
July-04 ¹	0	0
August-04 ¹	0	0
September-04 ¹	0	0
October-04 ¹	0	0
November-04 ¹	0	0
December-04 ¹	0	0
January-05 ¹	0	0
February-05 ¹	0	0
March-05 ¹	0	0
April-05 ¹	0	0
May-05 ¹	0	0
June-05 ¹	0	0
July-05 ¹	0	0
August-05 ¹	0	0
September-05 ¹	0	0
October-05 ¹	0	0
November-05 ¹	0	0
December-05 ¹	0	0
January-06 ¹	0	0
February-06 ¹	0	0
March-06 ¹	0	0
April-06 ¹	0	0
May-06 ¹	0	0
June-06 ¹	0	0
July-06 ¹	736	2,620
August-06 ¹	736	2,620
September-06	736	2,620
October-06	736	2,620
November-06	720	2,571
December-06	744	2,478
January-07	743	2,811
total/ AVERAGES:	5150	764

year 1 0
 year 2

Note 1: Flowrate and operating hours for the odor control flare was not available from the start date July 1, 2006 to Jan 31, 2007, therefore the average from the available data was used for the previous months.

Standard Conditions, Constants, and Typical Values

Category	Value	Equivalent
Standard Temperature ¹	60 °F	519.7 °R
Universal Gas Constant	0.7302 atm-ft ³ /lb-mol-°R	
Pressure ¹	1 atm	
Methane Heating Value ²	1,000 Btu/ft ³	
LFG Methane Component ²	50%	
LFG Typical Heating Value	500 Btu/ft ³	
LFG Temperature ³	100 °F	559.7 °R
LFG Moisture ³	8.0%	

Fuel & Equipment - Open Flare

Flare Information	Value	Equivalent
No. of Hours of Operation Per Day ³		hr
No. of Days in Averaging Period ³		day
Operation Period ³	5,150 hr	
LFG inlet flow, standard ³	764 scfm	
LFG Inlet Flow, dry standard	703 dscfm	
Heat Input	22.9 MMBtu/hr	
Design Flare Operating Temperature ⁴	1,400 °F	1,859.7 °R
Flare Tip Flow, standard	764 scfm	
Flare Tip Flow, actual	823 acfm	
Flare Tip Diameter ⁴	1.00 ft	
Flare Tip Exhaust Velocity	1,048 ft/min	17.5 ft/s
Flare Heat release (gross) ⁵	1,604,886 cal/s	
Flare Heat release (net) ⁵	1,182,388	
Flare Tip Height, above local grade ^{4,5}	35 ft	35 ft
Effective Exhaust Velocity ^{5,6}	20.0 m/s	65.6 ft/s
Effective Exhaust Temperature ^{5,6}	1,273 K	1,832 °F
Effective Exhaust Diameter ^{5,6,7}	1.09 m	3.57 ft

¹ Industrial STP (60°F, 30.00 in. Hg, 1 atm);

² Typical

³ Derived site test data

⁴ Flare manufacturer

⁵ TCEQ, Interoffice Memorandum, *Technical Basis for Flare Parameters*, (September 10, 2004)

⁶ Used in air modeling

⁷ Based on a landfill gas molecular weight of 30.03

⁸ Average of 3 stack tests

Emissions Calculations
Open Flares

Okeechobee Landfill
Okeechobee, Fla.

Criteria Pollutant Emissions - Open Flare

Operation Period	5,150 hr
LFG inlet flow, standard	764 scfm
Heat Input	23 MMBtu/hr

SO₂ Emission Rate							
SO ₂ concentration in exhaust gas		5813.2 ppmv					
SO ₂ emission rate		45.0 lb/hr		116 tpy			
LFG Compound	CAS	MW (lb/lb-mol)	Conc (ppmv) ¹	Control Eff ^{1,2}	Individual Compound Contribution to SO ₂		
					No. of S Atoms	S Conc (ppmv)	SO ₂ Emiss (lb/hr)
Carbon Disulfide	75-15-0	76.13	0.58	100%	2	1.16	9.0E-03
Carbonyl Sulfide	463-58-1	60.07	0.49	100%	1	0.49	3.8E-03
Dimethyl Sulfide (methyl sulfide)	75-18-3	62.13	7.82	100%	1	7.82	6.1E-02
Ethyl Mercaptan (ethanethiol)	75-08-1	62.13	1.25	100%	1	1.25	9.7E-03
Hydrogen Sulfide	7783-06-4	34.08	5800.0	100%	1	5800	4.5E+01
Methyl Mercaptan	74-93-1	48.11	2.49	100%	1	2.49	1.9E-02
Total Contribution to SO ₂ :						5813	45
PM₁₀ Emission Rate							
PM emission factor ³		17 lb/MM dscf CH ₄					
PM emission rate		0.36 lb/hr		0.46 tpy			
NO₂ Emission Rate							
NO ₂ emission factor ³		0.068 lb/MMBtu					
NO ₂ emission rate		1.56 lb/hr		2.0 tpy			
CO Emission Rate							
CO emission factor ³		0.37 lb/MMBtu					
CO emission rate		8.5 lb/hr		10.9 tpy			
NMOC Emission Rate							
NMOC conc inlet gas ¹		595 ppmv					
MW hexane		86.18 lb/lb-mol					
destruction efficiency		98%					
mass NMOC inlet gas		6.20 lb/hr					
NMOC emission rate		0.13 lb/hr		0.17 tpy			
VOC Emission Rate							
NMOC conc inlet gas ¹		595 ppmv					
VOC fraction of NMOC ¹		39%					
VOC concentration in inlet gas		232 ppmv					
MW hexane		86.18 lb/lb-mol					
mass VOC inlet gas		2.42 lb/hr					
destruction efficiency		98%					
VOC emission rate		0.05 lb/hr		0.06 tpy			

¹ EPA, *Compilation of Air Pollutant Emission Factors, Volume I. Stationary Point and Area Sources, 5th Ed.* (November 1998).

² NSPS minimum required control efficiency

³ LFG Specialties Inc. (typical)

Note: values in shaded cells are the most likely to change (as warranted)

Section II Appendix B Page 45/47
Application 1270-2

Emissions Calculations
Open Flares

Okeechobee Landfill
Okeechobee, Fla.

Air Toxics Emissions from Open Flare

The flare's inlet flow is **764** scfm

LFG Compound	HAP	CAS	MW (lb/lb-mol)	Compound Conc & Mass in Inlet Gas		Control Eff ^{1,2}	Flare Exhaust	
				(ppmv) ³	(lb/hr)		(lb/hr) ⁴	(tpy) ⁴
1,1,1 - Trichloroethane (methyl chloroform)	x	71-55-6	133.41	0.48	7.74E-03	98.0%	1.55E-04	1.99E-04
1,1,2,2 - Tetrachloroethane	x	79-34-5	167.85	1.11	2.25E-02	98.0%	4.50E-04	5.80E-04
1,1,2 - Trichloroethane (1,1,2 TCA)	x	79-00-5	133.41	0.10	1.61E-03	98.0%	3.22E-05	4.15E-05
1,1 - Dichloroethane (ethylidene dichloride)	x	75-34-3	98.96	2.35	2.81E-02	98.0%	5.62E-04	7.24E-04
1,1 - Dichloroethene (vinylidene chloride)	x	75-35-4	96.94	0.20	2.35E-03	98.0%	4.71E-05	6.06E-05
1,2 - Dichloroethane (ethylene dichloride)	x	107-06-2	98.96	0.41	4.87E-03	98.0%	9.73E-05	1.25E-04
1,2 - Dichloropropane (propylene dichloride)	x	78-87-5	112.99	0.18	2.46E-03	98.0%	4.92E-05	6.33E-05
2-Propanol (isopropyl alcohol)	-	67-63-0	60.11	50.1	3.64E-01	98.0%	7.28E-03	9.37E-03
Acetone (2-propanone)	-	67-64-1	58.08	7.01	4.92E-02	98.0%	9.84E-04	1.27E-03
Acrylonitrile (Propenenitrile)	x	107-13-1	53.06	6.33	4.06E-02	98.0%	8.12E-04	1.05E-03
Benzene	x	71-43-2	78.12	1.91	1.80E-02	98.0%	3.61E-04	4.64E-04
Bromodichloromethane	-	75-27-4	163.83	3.13	6.20E-02	98.0%	1.24E-03	1.60E-03
Butane	-	106-97-8	58.12	5.03	3.53E-02	98.0%	7.07E-04	9.10E-04
Carbon Disulfide	x	75-15-0	76.14	0.58	5.34E-03	98.0%	1.07E-04	1.37E-04
Carbon Tetrachloride	x	56-23-5	153.84	0.004	7.44E-05	98.0%	1.49E-06	1.91E-06
Carbonyl Sulfide	x	463-58-1	60.07	0.49	3.56E-03	98.0%	7.11E-05	9.16E-05
Chlorobenzene (monochlorobenzene)	x	108-90-7	112.56	0.25	3.45E-03	98.0%	6.91E-05	8.90E-05
Chlorodifluoromethane (CFC-22, freon-22)	-	75-45-6	86.47	1.30	1.36E-02	98.0%	2.72E-04	3.50E-04
Chloroethane (ethyl chloride)	x	75-00-3	64.52	1.25	9.75E-03	98.0%	1.95E-04	2.51E-04
Chloroform (trichloromethane)	x	67-66-3	119.38	0.03	4.33E-04	98.0%	8.66E-06	1.11E-05
Chloromethane (methyl chloride)	x	74-87-3	50.49	1.21	7.38E-03	98.0%	1.48E-04	1.90E-04
1,4 Dichlorobenzene (p-dichlorobenzene)	x	106-46-7	147	0.21	3.78E-03	98.0%	7.57E-05	9.74E-05
Dichlorodifluoromethane (CFC-12, freon-12)	-	75-71-8	120.91	15.7	2.29E-01	98.0%	4.59E-03	5.91E-03
Dichlorofluoromethane (freon-21)	-	75-43-4	102.92	2.62	3.26E-02	98.0%	6.52E-04	8.39E-04
Dichloromethane (methylene chloride)	x	75-09-2	84.93	14.3	1.47E-01	98.0%	2.94E-03	3.78E-03
Dimethyl Sulfide (methyl sulfide)	-	75-18-3	62.13	7.82	5.87E-02	98.0%	1.17E-03	1.51E-03
Ethane	-	74-84-0	30.07	889	3.23E+00	98.0%	6.46E-02	8.32E-02
Ethanol (ethyl alcohol)	-	64-17-5	46.08	27.2	1.51E-01	98.0%	3.03E-03	3.90E-03
Ethylbenzene	x	100-41-4	106.17	4.61	5.91E-02	98.0%	1.18E-03	1.52E-03
Ethyl Mercaptan (ethanethiol)	-	75-08-1	62.13	1.25	9.38E-03	98.0%	1.88E-04	2.42E-04
Ethylene dibromide (1,2 dibromoethane)	x	106-93-4	187.88	0.001	2.27E-05	98.0%	4.54E-07	5.85E-07
Fluorotrichloromethane (CFC-11, freon-11)	-	75-69-4	137.37	0.76	1.26E-02	98.0%	2.52E-04	3.25E-04
Hexane	x	110-54-3	86.18	6.57	6.84E-02	98.0%	1.37E-03	1.76E-03
Hydrogen Sulfide ⁵	-	7783-06-4	34.08	5800	2.39E+01	99.9%	2.39E-02	3.08E-02
Mercury (total)	x	7439-97-6	200.61	2.92E-04	7.08E-06	0.0%	7.08E-06	9.11E-06
Methyl Ethyl Ketone (2-butanone)	-	78-93-3	72.11	7.09	6.18E-02	98.0%	1.24E-03	1.59E-03
Methyl Isobutyl Ketone (hexone)	x	108-10-1	100.16	1.87	2.26E-02	98.0%	4.53E-04	5.83E-04
Methyl Mercaptan	-	74-93-1	48.11	2.49	1.45E-02	98.0%	2.90E-04	3.73E-04
Pentane	-	109-66-0	72.15	3.29	2.87E-02	98.0%	5.74E-04	7.39E-04
Tetrachloroethylene (perchloroethylene, -ethene)	x	127-18-4	165.83	3.73	7.47E-02	98.0%	1.49E-03	1.92E-03
Propane	-	74-98-6	44.1	11.1	5.92E-02	98.0%	1.18E-03	1.52E-03
Toluene (methylbenzene)	x	108-88-3	92.14	39.3	4.38E-01	98.0%	8.75E-03	1.13E-02
Trichloroethylene (trichloroethene)	x	79-01-6	131.38	2.82	4.48E-02	98.0%	8.95E-04	1.15E-03
t - 1,2 - Dichloroethene (1,2 dichloroethylene)	-	156-60-5	96.94	2.84	3.33E-02	98.0%	6.65E-04	8.57E-04
Vinyl Chloride (chloroethylene, VCM)	x	75-01-4	62.50	7.34	5.54E-02	98.0%	1.11E-03	1.43E-03
Xylenes (m, o, p)	x	1330-20-7	106.17	12.1	1.55E-01	98.0%	3.10E-03	4.00E-03
Hydrogen Chloride ^{3,4}	x	7647-01-0	36.50	42.0	1.85E-01	0.0%	1.85E-01	2.38E-01
Total HAP							0.21	2.70E-01
Maximum Single HAP							0.19	0.24
Hydrogen Sulfide⁵							0.03	0.04

¹ EPA, *Compilation of Air Pollutant Emission Factors, Volume I, Stationary Point and Area Sources*, 5th Ed. (November 1998).

² NSPS minimum required control efficiency

³ Product of combustion

⁴ Because HCl is a production of combustion, a default outlet concentration is listed, AP-42, Section 2.4.4.

⁵ 2005

Letter Symbol	Definition
acfm	actual cubic foot per minute
atm	atmosphere
atm-ft ³ /lb-mole ^o R	atmosphere cubic foot per pound mole degree Rankine
bhp	brake horsepower
Btu	british thermal unit
cal/s	calorie per second
CH ₄	methane
CO	carbon monoxide
d	day
D	effective exhaust diameter
dscfm	dry standard cubic foot, feet per minute
dsl/min	dry standard litre per minute
ft	foot
ft/min	foot per minute
ft/s	foot per second
ft ³	cubic foot
g	gram
HAP	hazardous air pollutant
Hg	mercury
HHV	higher heating value
hr	hour
HV	heating value
in.	inch
kW	kilowatt
kWh	kilowatt hour
l	litre
lb/hr	pound per hour
LHV	lower heating value
m	meter
m/s	meter per second
m ³	cubic meter
µg	microgram
mg	milligram
µg/dsl	microgram per dry standard litre
min	minute
MM	million
MMBtu	million british thermal units
mol	mole
MW	molecular weight
NMOC	non-methane organic compound
NO ₂	nitrogen dioxide
NO _x	nitrogen oxides
°F	degree Fahrenheit
Pb	lead
PM ₁₀	particulate matter less than or equal to 10 microns
ppmv	parts per million by volume
ppmw	parts per million by weight
q	gross heat release in cal/s
q _n	net heat release in cal/s
R	Rankine
R	universal gas constant
s	second
scf	standard cubic foot
scfm	standard cubic foot per minute
SO ₂	sulfur dioxide

Emissions Calculations
Open Flares

Okeechobee Landfill
Okeechobee, Fla.

Sample Calculations

Standard Conditions and Constants

$$R = ^\circ F + 460$$

standard temperature = 60 °F

standard pressure = 1 atm

Universal gas constant (R) = 0.7302 atm-ft³/lb-mol^oR

Flow

$$dscfm = scfm * (1 - \% \text{moisture})$$

$$acfm = scfm * (\text{actual temp} [^\circ R]) / (\text{standard temp} [^\circ R]) * \{ (\text{standard press} [\text{atm}]) / (\text{actual press} [\text{atm}]) \}$$

CO and NO_x Emissions

$$(\text{lb/MMbtu}) * (\text{MMbtu/hr}) = \text{lb/hr}$$

SO₂ Emissions

typically, 86% to 99.7% of sulfur compounds convert to SO₂ during combustion

$$\{ (\text{scfm}) * (60 \text{ min/hr}) * (\text{total sulfur concentration} [\text{ppmv}]) * (1 - \text{control efficiency}) * (\text{MW SO}_2) \} / \{ (R) * (T) \} = \text{lb/hr}$$

PM₁₀ Emissions

$$(\text{dscfm}) * (\text{CH}_4 \text{ component}) * (1 \text{E-}6 \text{ MMscf/scf}) * (\text{lb PM/MMscf CH}_4) * (60 \text{ min/hr}) = \text{lb/hr}$$

VOC Emissions

$$\{ (\text{scfm} * 60 \text{ min/hr} * \text{concentration}_{\text{compound}} [\text{ppmv}] * \text{MW}_{\text{compound}}) \} / \{ (R) * (T) \} * (1 - \text{control efficiency}) = \text{lb/hr}$$

OR

VOCs are 39 percent of NMOC, as prescribed in AP-42

$$\text{VOC concentration} [\text{ppmv}] = \text{NMOC concentration} [\text{as hexane}] * 39\%$$

flare and/or engines typically combust 98% of VOCs

$$\{ (\text{scfm} * 60 \text{ min/hr} * \text{concentration}_{\text{hexane}} [\text{ppmv}] * \text{MW}_{\text{hexane}}) \} / \{ (R) * (T) \} * (0.39) = \text{lb/hr}$$

LFG Compound Emissions

$$\{ (\text{scfm} * 60 \text{ min/hr} * \text{concentration}_{\text{compound}} [\text{ppmv}] * \text{MW}_{\text{compound}}) \} / \{ (R) * (T) \} * (1 - \text{control efficiency})$$

HCl Emissions

typically, 86% to 99.7% of chlorine compounds convert to HCl during combustion

(concentration_{compound} [ppm]) * (control efficiency) * (no. of chlorine atoms) = HCl concentration [ppm] in outlet gas from each compound

$$\{ \text{HCl concentration}_{\text{each compound}} [\text{ppm}] * \text{scfm} * \text{MW}_{\text{HCl}} \} / \{ (R) * (T) \} * (60 \text{ min/hr}) = \text{lb/hr}$$

OR

$$\{ (\text{scfm}) * (60 \text{ min/hr}) * (\text{HCl outlet concentration per AP-42} [\text{ppmv}]) * (1 - \text{control efficiency}) * (\text{MW}) \} / \{ (R) * (T) \} = \text{lb/hr}$$

Total Heat Release

$$(\text{btu/scf}) * (\text{scfm}) * (60 \text{ min/hr}) * (0.07 \text{ (cal/s)}) / (\text{btu/hr}) = \text{cal/s}$$

Appendix E
Permit Application No. 1270-2
Facility ID No. 0930104

LFG Generation Rates & Construction Schedule

Carlson Environmental Consultants, PC

400 West Windsor Street
Monroe, NC 28112
704-506-7312
704-283-9755 fax

January 8, 2007

MEMORANDUM

TO: Miguel Delgado, Okeechobee Landfill, Inc.

FROM: Kris Carlson, P.E., CEC

SUBJECT: LFG Recovery Projection Model and Graph
Berman Road Landfill – Okeechobee, FL
Clay Farms Landfill – Okeechobee, FL

Per your request, please find attached to this memorandum an updated LFG model depicting projected LFG generation and possible LFG recovery rates for the Berman Road Landfill (under the existing solid waste permit capacity) and the Clay Farms Landfill (Table 1). This model was adjusted to reflect a slightly higher potential maximum LFG generation/recovery than previous modeling has shown. The model includes only areas under current solid waste permits.

Please note that the CEC model is a first-order model, similar to the U.S. Environmental Protection Agency (EPA) Landfill Gas Emissions Model (LandGEM). CEC estimated the model inputs “k” and “Lo” based upon local rainfall data and historical LFG collection data for the Berman Road Landfill. Waste disposal amounts were provided by Okeechobee; however, it was unknown the actual year-to-year waste disposal amounts from 1981 to 1992. Okeechobee provided an estimate of 2,555,000 tons per year for Clay Farms (this is based on 7,000 tons per day over 365 days per year). Okeechobee provided an estimate for Berman Road of 2,007,500 tons per year from 2006 to projected landfill closures (this is based on 5,500 tons per day over 365 days per year). Okeechobee provided the total waste mass for the sites: estimated at 23,431,195 tons for Berman Road and 119,324,245 tons for Clay Farms. These waste capacities are based on the existing permitted volumes and the projections for the Berman Road Expansion by SCS Engineers. Per Okeechobee, the waste density was assumed to be 2,000 pounds per cubic yard or a 1:1 ratio between tons and cubic yards.

For modeling purposes only, CEC estimated a LFG collection system would be installed and maintained aggressively and the landfill will be capped as soon as waste cells are filled to final grade. The average collection efficiency assumed was 80 percent during active landfill operations, with the LFG collection increasing to 100 percent after landfill closure. A 90 percent collection efficiency was assumed for the combined Clay Farms

MEMORANDUM

January 8, 2007

Page 2 of 2

and Berman Road model to reflect the final cover on Berman Road and the active waste filling on Clay Farms. Please note that no factor of safety was added to the modeling.

This report has been prepared in accordance with the care and skill generally exercised by reputable LFG professionals, under similar circumstances, in this or similar localities. No other warranty, express or implied, is made as to the professional opinions presented herein. Please note that these LFG models, like any other mathematical projection, should be used only as a tool, and not an absolute declaration of the rate of LFG generation or LFG recovery potential. Changes in the landfill property use and conditions (for example, variations in rainfall, water levels, landfill operations, LFG expansions, final cover systems, or other factors) may affect LFG generation and future gas recovery at the site. CEC does not guarantee the quantity or the quality of available landfill gas.

I appreciate the opportunity to provide LFG consulting services to Okeechobee Landfill, Inc. Please feel free to give me a call at (704) 506-7312 if I can be of further service to you.

Attachments

**TABLE 1. LFG RECOVERY/GENERATION PROJECTION
BERMAN ROAD & CLAY FARMS LANDFILLS - OKEECHOBEE, FL
(CURRENT PERMITTED AREAS ONLY)**

Year	Disposal Rate (tons/yr)	Refuse In-Place (tons)	Estimated LFG Generation Potential (scfm)	Est. LFG System Coverage (%)	Est. LFG Recovery from Existing and Planned LFG System (scfm)
1981	28,637	28,637	0	0%	0
1982	28,637	57,274	27	0%	0
1983	28,637	85,911	52	0%	0
1984	28,637	114,548	75	0%	0
1985	28,637	143,185	96	0%	0
1986	28,637	171,822	116	0%	0
1987	28,637	200,459	134	0%	0
1988	28,637	229,096	151	0%	0
1989	28,637	257,733	166	0%	0
1990	28,637	286,370	181	0%	0
1991	28,637	315,007	194	0%	0
1992	42,008	357,015	206	0%	0
1993	186,295	543,310	230	0%	0
1994	392,671	935,981	388	0%	0
1995	452,973	1,388,954	729	0%	0
1996	457,020	1,845,974	1,100	0%	0
1997	655,581	2,501,555	1,447	70%	1,013
1998	701,917	3,203,472	1,955	65%	1,271
1999	758,554	3,962,026	2,468	60%	1,481
2000	954,901	4,916,927	2,994	55%	1,647
2001	757,288	5,674,215	3,665	50%	1,833
2002	664,891	6,339,106	4,099	50%	2,049
2003	693,349	7,032,455	4,411	60%	2,647
2004	2,231,950	9,264,405	4,727	70%	3,309
2005	2,246,790	11,511,195	6,471	70%	4,530
2006	2,007,500	13,518,695	8,095	80%	6,476
2007	2,007,500	15,526,195	9,368	80%	7,494
2008	2,007,500	17,533,695	10,543	80%	8,434
2009	2,007,500	19,541,195	11,628	80%	9,302
2010	2,007,500	21,548,695	12,629	80%	10,104
2011	2,007,500	23,556,195	13,554	80%	10,843
2012	2,555,000	26,111,195	14,407	90%	12,967
2013	2,555,000	28,666,195	15,712	90%	14,141
2014	2,555,000	31,221,195	16,916	90%	15,225
2015	2,555,000	33,776,195	18,028	90%	16,225
2016	2,555,000	36,331,195	19,055	90%	17,149
2017	2,555,000	38,886,195	20,002	90%	18,002
2018	2,555,000	41,441,195	20,877	90%	18,789
2019	2,555,000	43,996,195	21,684	90%	19,516
2020	2,555,000	46,551,195	22,429	90%	20,186
2021	2,555,000	49,106,195	23,117	90%	20,805
2022	2,555,000	51,661,195	23,752	90%	21,377
2023	2,555,000	54,216,195	24,338	90%	21,905
2024	2,555,000	56,771,195	24,880	90%	22,392
2025	2,555,000	59,326,195	25,379	90%	22,841
2026	2,555,000	61,881,195	25,840	90%	23,256
2027	2,555,000	64,436,195	26,266	90%	23,639
2028	2,555,000	66,991,195	26,659	90%	23,993
2029	2,555,000	69,546,195	27,022	90%	24,320
2030	2,555,000	72,101,195	27,357	90%	24,621
2031	2,555,000	74,656,195	27,666	90%	24,899
2032	2,555,000	77,211,195	27,951	90%	25,156

**TABLE 1. LFG RECOVERY/GENERATION PROJECTION
BERMAN ROAD & CLAY FARMS LANDFILLS - OKEECHOBEE, FL
(CURRENT PERMITTED AREAS ONLY)**

Year	Disposal Rate (tons/yr)	Refuse In-Place (tons)	Estimated LFG Generation Potential (scfm)	Est. LFG System Coverage (%)	Est. LFG Recovery from Existing and Planned LFG System (scfm)
2033	2,555,000	79,766,195	28,215	90%	25,393
2034	2,555,000	82,321,195	28,458	90%	25,612
2035	2,555,000	84,876,195	28,682	90%	25,814
2036	2,555,000	87,431,195	28,889	90%	26,001
2037	2,555,000	89,986,195	29,081	90%	26,173
2038	2,555,000	92,541,195	29,257	90%	26,332
2039	2,555,000	95,096,195	29,420	90%	26,478
2040	2,555,000	97,651,195	29,571	90%	26,614
2041	2,555,000	100,206,195	29,710	90%	26,739
2042	2,555,000	102,761,195	29,838	90%	26,854
2043	2,555,000	105,316,195	29,956	90%	26,961
2044	2,555,000	107,871,195	30,066	90%	27,059
2045	2,555,000	110,426,195	30,166	90%	27,150
2046	2,555,000	112,981,195	30,260	90%	27,234
2047	2,555,000	115,536,195	30,345	90%	27,311
2048	2,555,000	118,091,195	30,425	90%	27,382
2049	2,555,000	120,646,195	30,498	90%	27,448
2050	2,555,000	123,201,195	30,566	90%	27,509
2051	2,555,000	125,756,195	30,628	90%	27,565
2052	2,555,000	128,311,195	30,686	90%	27,617
2053	2,555,000	130,866,195	30,739	90%	27,665
2054	2,555,000	133,421,195	30,788	90%	27,709
2055	2,555,000	135,976,195	30,833	90%	27,750
2056	2,555,000	138,531,195	30,875	90%	27,788
2057	2,555,000	141,086,195	30,914	90%	27,822
2058	1,669,245	142,755,440	30,949	90%	27,854
2059	0	142,755,440	30,146	100%	30,146
2060	0	142,755,440	27,828	100%	27,828
2061	0	142,755,440	25,689	100%	25,689
2062	0	142,755,440	23,714	100%	23,714
2063	0	142,755,440	21,890	100%	21,890
2064	0	142,755,440	20,207	100%	20,207
2065	0	142,755,440	18,654	100%	18,654
2066	0	142,755,440	17,220	100%	17,220
2067	0	142,755,440	15,896	100%	15,896
2068	0	142,755,440	14,674	100%	14,674
2069	0	142,755,440	13,545	100%	13,545
2070	0	142,755,440	12,504	100%	12,504
2071	0	142,755,440	11,543	100%	11,543
2072	0	142,755,440	10,655	100%	10,655

Methane Content of LFG Adjusted to:
 Selected Decay Rate Constant (k):
 Selected Ultimate Methane Recovery Rate (Lo):

50%
 0.080 1/yr
 3,360 cu ft/ton

OKEECHOBEE LANDFILL
 AIR CONSTRUCTION PERMIT APPLICATION 1270-2
 INSTALLATION SCHEDULE FOR CONTROL DEVICES (STANDARD OPERATING SCENARIO)

Year	Refuse In-Place (tons)	Estimated LFG Recovery, Existing and Planned LFG System (scfm) *	Existing and Proposed Control Device Installation							Potential to Emit without Odor Control Flare (scfm)	Potential to Emit Including Odor Control Flare (scfm)	Excess Potential (PTE - LFGgen w/o odor control flare)	Comments
			Enclosed Flares (3,000scfm)	Utility Flares (3,300 scfm)	Utility Flares (1,100 scfm)	Odor Control Flare (3300-scfm)	Turbines (4,000 scfm)	Backup Flares (3.3K & 3K scfm)	BACT				
CURRENT	13,518,695	6,476	2	1		1			No	9,300	12,600	2,824	
2007	15,526,195	7,494	2	1		1			No	9,300	12,600	1,806	
2008	17,533,695	8,434	2	1		1			No	9,300	12,600	866	
2009	19,541,195	9,302	2	2		1			No	12,600	15,900	3,298	
2010	21,548,695	10,104				1	3	4	Yes	12,000	15,300	1,896	
2011	23,556,195	10,843				1	3	4	Yes	12,000	15,300	1,157	
2012	26,111,195	12,967				1	4	4	Yes	16,000	19,300	3,033	
2013	28,666,195	14,141				1	4	4	Yes	16,000	19,300	1,859	
2014	31,221,195	15,225				1	4	4	Yes	16,000	19,300	775	
2015	33,776,195	16,225				1	5	4	Yes	20,000	23,300	3,775	
2016	36,331,195	17,149				1	5	4	Yes	20,000	23,300	2,851	
2017	38,886,195	18,002				1	5	4	Yes	20,000	23,300	1,998	
2018	41,441,195	18,789				1	5	4	Yes	20,000	23,300	1,211	
2019	43,996,195	19,516				1	5	4	Yes	20,000	23,300	484	
2020	46,551,195	20,186				1	6	4	Yes	24,000	27,300	3,814	
2021	49,106,195	20,805				1	6	4	Yes	24,000	27,300	3,195	
2022	51,661,195	21,377				1	6	4	Yes	24,000	27,300	2,623	
2023	54,216,195	21,905				1	6	4	Yes	24,000	27,300	2,095	
2024	56,771,195	22,392				1	6	4	Yes	24,000	27,300	1,608	
2025	59,326,195	22,841				1	6	4	Yes	24,000	27,300	1,159	
2026	61,881,195	23,256				1	6	4	Yes	24,000	27,300	744	
2027	64,436,195	23,639				1	6	4	Yes	24,000	27,300	361	
2028	66,991,195	23,993				1	7	4	Yes	28,000	31,300	4,007	
2029	69,546,195	24,320				1	7	4	Yes	28,000	31,300	3,680	
2030	72,101,195	24,621				1	7	4	Yes	28,000	31,300	3,379	
2031	74,656,195	24,899				1	7	4	Yes	28,000	31,300	3,101	
2032	77,211,195	25,156				1	7	4	Yes	28,000	31,300	2,844	
2033	79,766,195	25,393				1	7	4	Yes	28,000	31,300	2,607	
2034	82,321,195	25,612				1	7	4	Yes	28,000	31,300	2,388	

OKEECHOBEE LANDFILL
 AIR CONSTRUCTION PERMIT APPLICATION 1270-2
 INSTALLATION SCHEDULE FOR CONTROL DEVICES (STANDARD OPERATING SCENARIO)

Year	Refuse In-Place (tons)	Estimated LFG Recovery, Existing and Planned LFG System (scfm) *	Existing and Proposed Control Device Installation							Potential to Emit without Odor Control Flare (scfm)	Potential to Emit Including Odor Control Flare (scfm)	Excess Potential (PTE - LFGgen w/o odor control flare)	Comments
			Enclosed Flares (3,000scfm)	Utility Flares (3,300 scfm)	Utility Flares (1,100 scfm)	Odor Control Flare (3300-scfm)	Turbines (4,000 scfm)	Backup Flares (3.3K & 3K scfm)	BACT				
CURRENT	13,518,695	6,476	2	1		1			No	9,300	12,600	2,824	
2035	84,876,195	25,814				1	7	4	Yes	28,000	31,300	2,186	
2036	87,431,195	26,001				1	7	4	Yes	28,000	31,300	1,999	
2037	89,986,195	26,173				1	7	4	Yes	28,000	31,300	1,827	
2038	92,541,195	26,332				1	7	4	Yes	28,000	31,300	1,668	
2039	95,096,195	26,478				1	7	4	Yes	28,000	31,300	1,522	
2040	97,651,195	26,614				1	7	4	Yes	28,000	31,300	1,386	
2041	100,206,195	26,739				1	7	4	Yes	28,000	31,300	1,261	
2042	102,761,195	26,854				1	7	4	Yes	28,000	31,300	1,146	
2043	105,316,195	26,961				1	7	4	Yes	28,000	31,300	1,039	
2044	107,871,195	27,059				1	7	4	Yes	28,000	31,300	941	
2045	110,426,195	27,150				1	7	4	Yes	28,000	31,300	850	
2046	112,981,195	27,234			1	1	7	4	Yes	29,100	32,400	1,866	
2047	115,536,195	27,311			1	1	7	4	Yes	29,100	32,400	1,789	
2048	118,091,195	27,382			1	1	7	4	Yes	29,100	32,400	1,718	
2049	120,646,195	27,448			1	1	7	4	Yes	29,100	32,400	1,652	
2050	123,201,195	27,509			1	1	7	4	Yes	29,100	32,400	1,591	
2051	125,756,195	27,565			1	1	7	4	Yes	29,100	32,400	1,535	
2052	128,311,195	27,617			1	1	7	4	Yes	29,100	32,400	1,483	
2053	130,866,195	27,665			1	1	7	4	Yes	29,100	32,400	1,435	
2054	133,421,195	27,709			1	1	7	4	Yes	29,100	32,400	1,391	
2055	135,976,195	27,750			1	1	7	4	Yes	29,100	32,400	1,350	
2056	138,531,195	27,788			1	1	7	4	Yes	29,100	32,400	1,312	
2057	141,086,195	27,822			1	1	7	4	Yes	29,100	32,400	1,278	
2058	142,755,440	27,854			1	1	7	4	Yes	29,100	32,400	1,246	NOTE 1
2059	142,755,440	30,146				1	7	4	Yes		31,300	1,154	NOTE 2
2060	142,755,440	27,828					7	6	Yes		28,000	172	NOTE 3
2061	142,755,440	25,689					7	6	Yes		28,000	2,311	
2062	142,755,440	23,714					6	6	Yes		24,000	286	

OKEECHOBEE LANDFILL
 AIR CONSTRUCTION PERMIT APPLICATION 1270-2
 INSTALLATION SCHEDULE FOR CONTROL DEVICES (STANDARD OPERATING SCENARIO)

Year	Refuse In-Place (tons)	Estimated LFG Recovery, Existing and Planned LFG System (scfm) *	Existing and Proposed Control Device Installation							Potential to Emit without Odor Control Flare (scfm)	Potential to Emit Including Odor Control Flare (scfm)	Excess Potential (PTE - LFGgen w/o odor control flare)	Comments
			Enclosed Flares (3,000scfm)	Utility Flares (3,300 scfm)	Utility Flares (1,100 scfm)	Odor Control Flare (3300-scfm)	Turbines (4,000 scfm)	Backup Flares (3.3K & 3K scfm)	BACT				
CURRENT	13,518,695	6,476	2	1		1			No	9,300	12,600	2,824	
2063	142,755,440	21,890					6	6	Yes		24,000	2,110	
2064	142,755,440	20,207					6	6	Yes		24,000	3,793	
2065	142,755,440	18,654					5	6	Yes		20,000	1,346	
2066	142,755,440	17,220					5	6	Yes		20,000	2,780	
2067	142,755,440	15,896					4	6	Yes		16,000	104	
2068	142,755,440	14,674					4	6	Yes		16,000	1,326	
2069	142,755,440	13,545					4	6	Yes		16,000	2,455	
2070	142,755,440	12,504					4	6	Yes		16,000	3,496	
2071	142,755,440	11,543					3	6	Yes		12,000	457	
2072	142,755,440	10,655					3	6	Yes		12,000	1,345	

NOTE 1: Turbines and BACT installed by end of 2010. Existing backup flare used in production.

NOTE 2: Maximum potential to emit

NOTE 3: Odor control flare phased out and used in LFG collection system

OKEECHOBEE LANDFILL
 AIR CONSTRUCTION PERMIT APPLICATION 1270-2
 INSTALLATION SCHEDULE FOR CONTROL DEVICES (ALTERNATIVE OPERATING SCENARIO - FLARING ONLY)

Year	Refuse In-Place (tons)	Estimated LFG Recovery, Existing and Planned LFG System (scfm) *	Existing and Proposed Control Device							Potential to Emit without Odor Control Flare (scfm)	Potential to Emit Including Odor Control Flare & Backup (scfm)	Excess Potential (PTE - LFGgen w/o odor control flare)	Total Operating Flares w/odor control	Comments
			Enclosed Flares (3,000scfm)	Utility Flares (3,300 scfm)	Utility Flares (1,100 scfm)	Odor Control Flare (3300-scfm)	Turbines (4,000 scfm)	Backup Flares (3.3K & 3K scfm)	BACT					
2006	13,518,695	6,476	2			1		1	No	6,000	9,300	-476		
2007	15,526,195	7,494	2	2		1			No	12,600	15,900	5,106	5	
2008	17,533,695	8,434	2	2		1			No	12,600	15,900	4,166	5	
2009	19,541,195	9,302	2	2		1			No	12,600	15,900	3,298	5	
2010	21,548,695	10,104	2	2		1			Yes	12,600	15,900	2,496	5	NOTE 1
2011	23,556,195	10,843	2	2		1			Yes	12,600	15,900	1,757	5	
2012	26,111,195	12,967	2	3		1			Yes	15,900	19,200	2,933	6	
2013	28,666,195	14,141	2	3		1			Yes	15,900	19,200	1,759	6	
2014	31,221,195	15,225	2	3		1			Yes	15,900	19,200	675	6	
2015	33,776,195	16,225	2	4		1			Yes	19,200	22,500	2,975	7	
2016	36,331,195	17,149	2	4		1			Yes	19,200	22,500	2,051	7	
2017	38,886,195	18,002	2	4		1			Yes	19,200	22,500	1,198	7	
2018	41,441,195	18,789	2	4		1			Yes	19,200	22,500	411	7	
2019	43,996,195	19,516	2	5		1			Yes	22,500	25,800	2,984	8	
2020	46,551,195	20,186	2	5		1			Yes	22,500	25,800	2,314	8	
2021	49,106,195	20,805	2	5		1			Yes	22,500	25,800	1,695	8	
2022	51,661,195	21,377	2	5		1			Yes	22,500	25,800	1,123	8	
2023	54,216,195	21,905	2	5		1			Yes	22,500	25,800	595	8	
2024	56,771,195	22,392	2	5		1			Yes	22,500	25,800	108	8	
2025	59,326,195	22,841	2	6		1			Yes	25,800	29,100	2,959	9	
2026	61,881,195	23,256	2	6		1			Yes	25,800	29,100	2,544	9	
2027	64,436,195	23,639	2	6		1			Yes	25,800	29,100	2,161	9	
2028	66,991,195	23,993	2	6		1			Yes	25,800	29,100	1,807	9	
2029	69,546,195	24,320	2	6		1			Yes	25,800	29,100	1,480	9	
2030	72,101,195	24,621	2	6		1			Yes	25,800	29,100	1,179	9	
2031	74,656,195	24,899	2	6		1			Yes	25,800	29,100	901	9	
2032	77,211,195	25,156	2	6		1			Yes	25,800	29,100	644	9	
2033	79,766,195	25,393	2	6		1			Yes	25,800	29,100	407	9	
2034	82,321,195	25,612	2	6		1			Yes	25,800	29,100	188	9	

OKEECHOBEE LANDFILL
 AIR CONSTRUCTION PERMIT APPLICATION 1270-2
 INSTALLATION SCHEDULE FOR CONTROL DEVICES (ALTERNATIVE OPERATING SCENARIO - FLARING ONLY)

Year	Refuse In-Place (tons)	Estimated LFG Recovery, Existing and Planned LFG System (scfm) *	Existing and Proposed Control Device							Potential to Emit without Odor Control Flare (scfm)	Potential to Emit Including Odor Control Flare & Backup (scfm)	Excess Potential (PTE - LFGgen w/o odor control flare)	Total Operating Flares w/odor control	Comments
			Enclosed Flares (3,000scfm)	Utility Flares (3,300 scfm)	Utility Flares (1,100 scfm)	Odor Control Flare (3300-scfm)	Turbines (4,000 scfm)	Backup Flares (3.3K & 3K scfm)	BACT					
2006	13,518,695	6,476	2			1		1	No	6,000	9,300	-476		
2035	84,876,195	25,814	2	6		1			Yes	25,800	29,100	-14	9	
2036	87,431,195	26,001	2	7		1			Yes	29,100	32,400	3,099	10	
2037	89,986,195	26,173	2	7		1			Yes	29,100	32,400	2,927	10	
2038	92,541,195	26,332	2	7		1			Yes	29,100	32,400	2,768	10	
2039	95,096,195	26,478	2	7		1			Yes	29,100	32,400	2,622	10	
2040	97,651,195	26,614	2	7		1			Yes	29,100	32,400	2,486	10	
2041	100,206,195	26,739	2	7		1			Yes	29,100	32,400	2,361	10	
2042	102,761,195	26,854	2	7		1			Yes	29,100	32,400	2,246	10	
2043	105,316,195	26,961	2	7		1			Yes	29,100	32,400	2,139	10	
2044	107,871,195	27,059	2	7		1			Yes	29,100	32,400	2,041	10	
2045	110,426,195	27,150	2	7		1			Yes	29,100	32,400	1,950	10	
2046	112,981,195	27,234	2	7		1			Yes	29,100	32,400	1,866	10	
2047	115,536,195	27,311	2	7		1			Yes	29,100	32,400	1,789	10	
2048	118,091,195	27,382	2	7		1			Yes	29,100	32,400	1,718	10	
2049	120,646,195	27,448	2	7		1			Yes	29,100	32,400	1,652	10	
2050	123,201,195	27,509	2	7		1			Yes	29,100	32,400	1,591	10	
2051	125,756,195	27,565	2	7		1			Yes	29,100	32,400	1,535	10	
2052	128,311,195	27,617	2	7		1			Yes	29,100	32,400	1,483	10	
2053	130,866,195	27,665	2	7		1			Yes	29,100	32,400	1,435	10	
2054	133,421,195	27,709	2	7		1			Yes	29,100	32,400	1,391	10	
2055	135,976,195	27,750	2	7		1			Yes	29,100	32,400	1,350	10	
2056	138,531,195	27,788	2	7		1			Yes	29,100	32,400	1,312	10	
2057	141,086,195	27,822	2	7		1			Yes	29,100	32,400	1,278	10	
2058	142,755,440	27,854	2	7		1			Yes	29,100	32,400	1,246	10	
2059	142,755,440	30,146	2	7		1			Yes		32,400	2,254	10	Note 2, 3
2060	142,755,440	27,828	1	7		1		2	Yes		29,400	1,572	9	
2061	142,755,440	25,689	1	7				2	Yes		26,100	411	8	
2062	142,755,440	23,714	1	7				2	Yes		26,100	2,386	8	

OKEECHOBEE LANDFILL
 AIR CONSTRUCTION PERMIT APPLICATION 1270-2
 INSTALLATION SCHEDULE FOR CONTROL DEVICES (ALTERNATIVE OPERATING SCENARIO - FLARING ONLY)

Year	Refuse In-Place (tons)	Estimated LFG Recovery, Existing and Planned LFG System (scfm) *	Existing and Proposed Control Device							Potential to Emit without Odor Control Flare (scfm)	Potential to Emit Including Odor Control Flare & Backup (scfm)	Excess Potential (PTE - LFGgen w/o odor control flare)	Total Operating Flares w/odor control	Comments
			Enclosed Flares (3,000scfm)	Utility Flares (3,300 scfm)	Utility Flares (1,100 scfm)	Odor Control Flare (3300-scfm)	Turbines (4,000 scfm)	Backup Flares (3.3K & 3K scfm)	BACT					
2006	13,518,695	6,476	2			1		1	No	6,000	9,300	-476		
2063	142,755,440	21,890		7				3	Yes		23,100	1,210	7	
2064	142,755,440	20,207		7				3	Yes		23,100	2,893	7	
2065	142,755,440	18,654		6				4	Yes		19,800	1,146	6	
2066	142,755,440	17,220		6				4	Yes		19,800	2,580	6	
2067	142,755,440	15,896		5				5	Yes		16,500	604	5	
2068	142,755,440	14,674		5				5	Yes		16,500	1,826	5	
2069	142,755,440	13,545		5				5	Yes		16,500	2,955	5	
2070	142,755,440	12,504		4				6	Yes		13,200	696	4	
2071	142,755,440	11,543		4				6	Yes		13,200	1,657	4	
2072	142,755,440	10,655		4				6	Yes		13,200	2,545	4	

NOTE 1: Turbines and BACT installed by end of 2010. Existing backup flare used in production.

NOTE 2: Maximum potential to emit

NOTE 3: Odor control flare phased out at landfill closure and used for NSPS gas collection system.

File: O:\Show Offices - CAD Files\Hspanton\121525\121525B3.dwg
Plot Date/Time: Feb 27, 2007 - 4:29pm
Printed By: william.ander

OFFICE	DATE	DESIGNED BY	DRAWN BY	CHECKED BY	APPROVED BY	DRAWING NUMBER
PA	2/27/07		B. Spitzer			121525-B3

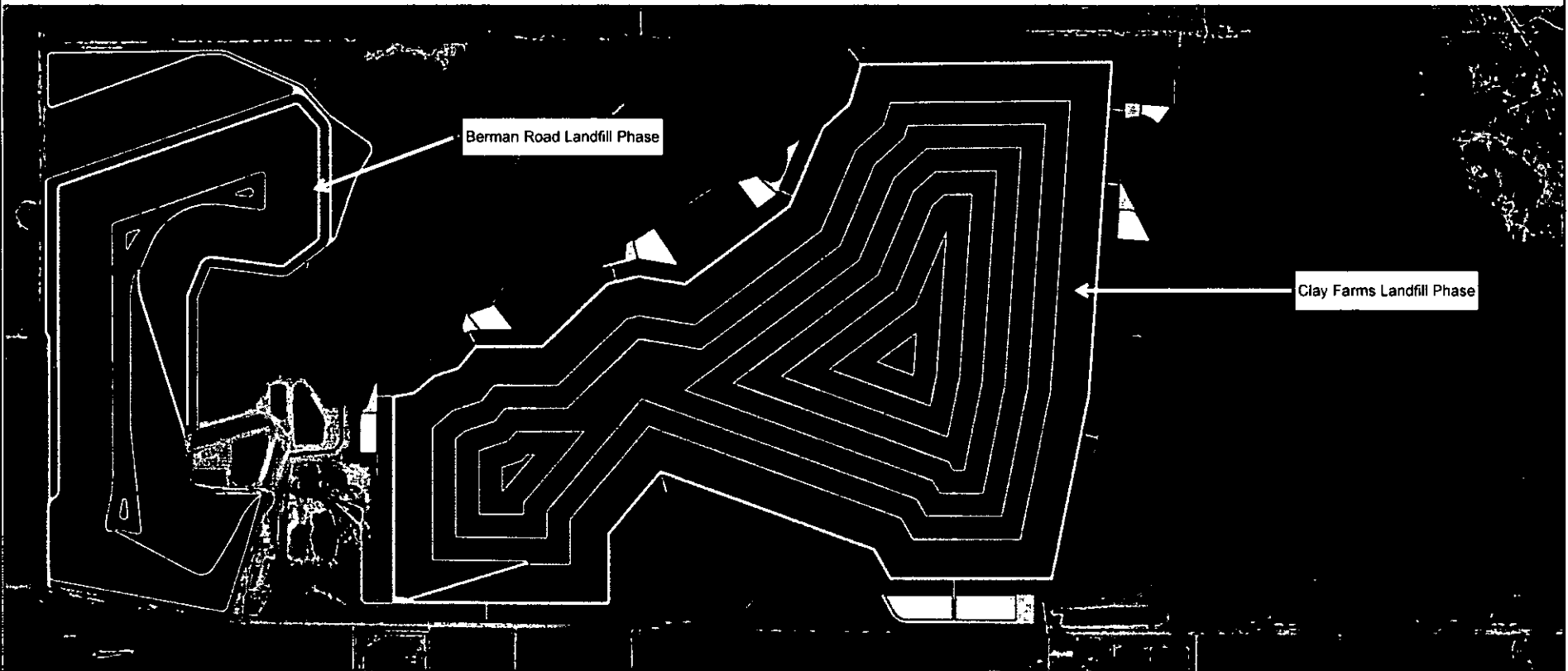
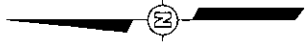

 Shaw Environmental, Inc.
OKEECHOBEE LANDFILL, INC. OKEECHOBEE, FLORIDA
FIGURE 4 AERIAL DEPICTION OF FUTURE LANDFILL
AIR CONSTRUCTION PERMIT APPLICATION 1270-2

Appendix F

Permit Application 1270-2

Facility ID No. 0930104



**MUNICIPAL SOLID WASTE LANDFILL
GAS COLLECTION AND CONTROL SYSTEM (GCCS)
STARTUP, SHUTDOWN, AND MALFUNCTION
PLAN**

**Okeechobee Landfill, Inc.
Berman Road Landfill
Okeechobee, Florida**

Prepared by:
Okeechobee Landfill, Inc.
10800 N.E. 128th Avenue
Okeechobee, FL 34972
(863)357-0111

Date of Issuance:
August 8, 2005

This version of this plan has been superseded.

If the box above has been checked, complete the following information:

This copy of the plan may be discarded after _____
(enter the date that is 5 years after date on which this version was superseded by a newer version)

MUNICIPAL SOLID WASTE LANDFILL GAS COLLECTION AND CONTROL SYSTEM (GCCS)

STARTUP, SHUTDOWN, AND MALFUNCTION PLAN

Berman Road Landfill Okeechobee, Florida

This startup, shutdown and malfunction (SSM) plan (SSM Plan) was prepared by Okeechobee Landfill, Inc. (OLI) in order to comply with the requirements of 40 CFR 63.6(e)(3), as this facility is subject to 40 CFR Part 63, Subpart AAAAA, the National Emission Standard for Hazardous Air Pollutants (NESHAPs) for Municipal Solid Waste (MSW) landfills. The SSM Plan contains all of the required elements set forth within 40 CFR 63.6(e).

This SSM Plan will be revised if the procedures described herein do not adequately address any malfunction or startup/shutdown events that occur at the facility. A copy of the original plan and all revisions/addenda will be kept on file at the facility for at least five (5) years. John Van Gessel, Vice President and Assistant Secretary and Mike Stallard, District Manager are responsible for assuring that the most recent copy of this SSM Plan is made available to all personnel involved with the landfill gas (LFG) collection and control system (GCCS) at Berman Road Landfill as well as to appropriate regulatory agency personnel for inspection.

Name of Plan Preparer: _____
Name Date

Approved:
John Van Gessel
Vice President and Assistant Secretary: _____
Name Date

TABLE OF CONTENTS

1	Revision History	4
2	Introduction.....	5
2.1	Purpose and Scope	5
2.2	Description Of SSM Plan.....	5
2.3	Site Equipment Subject To This SSM Plan	6
2.4	Site Equipment NOT Subject To This SSM Plan	6
3	Startup/Shutdown Plan.....	6
3.1	How to Identify a GCCS Startup / Shutdown Event.....	6
3.2	Actions To Take When the GCCS is Started-Up.....	7
3.2.1	Gas Mover and Collection System	7
3.2.2	Control Device(s):.....	8
3.3	Actions To Take When The GCCS Is Shutdown	8
3.3.1	Collection System	8
3.3.2	Control Device(s):.....	9
3.4	What to Record for All Startup / Shutdown Events.....	10
3.5	Whom to Notify at the Facility in Case of a Startup/Shutdown Event	10
3.6	What to Report for a Startup/Shutdown Event	10
4	Malfunction Plan.....	12
4.1	How to Identify a GCCS Malfunction	12
4.2	Actions to Take When The GCCS Malfunctions—All Malfunctions	13
4.3	Loss of LFG Flow/Gas Mover Malfunction	15
4.4	Loss of Electrical Power	15
4.5	Low Temperature Conditions at the Control Device.....	15
4.6	Loss of Flame at the Control Device	16
4.7	Malfunctions of Flow Monitoring/Recording Device	16
4.8	Malfunctions of Temperature Monitoring/Recording Device	16
4.9	Collection Well and Pipe Failures	17
4.10	Other Control Device Malfunctions.....	17
4.11	Malfunctions of Field Monitoring Equipment.....	17
4.12	Buildup of Liquid in Piping	18
4.13	What to Record for a Malfunction	18
4.14	Whom to Notify at the Facility in Case of a Malfunction	19
4.15	What to Report for a Malfunction Event	19

Appendices

- A Common Causes and Response Actions for GCCS Malfunctions
- B SSM Reporting Forms

1 Revision History

Add the effective date of the most-recent revision to the list below. Do not overwrite or delete any dates. This is intended to be a complete record of all revisions made to this plan and assists in making certain that all plan versions are retained for at least 5 years as required by §63.6(e)(3)(v).

Date of Initial Issuance
January 16, 2004
Revision Dates
January 26, 2005
August 8, 2005

2 Introduction

2.1 Purpose and Scope

The municipal solid waste (MSW) landfill owner or operator of an affected source must develop and implement a written Startup, Shutdown and Malfunction (SSM) Plan that describes, in detail, procedures for operating and maintaining the source during periods of startup, shutdown and malfunction; a program of corrective action for malfunctioning processes; and air pollution control and monitoring equipment used to comply with the relevant standards. The purpose of the SSM Plan is to:

- Ensure that, at all times, the MSW landfill owner or operator operates and maintains the affected source, including associated air pollution control and monitoring equipment, in a manner consistent with safety and good air pollution control practices for minimizing emissions to the levels required by the relevant standards;
- Ensure that MSW landfill owners or operators are prepared to correct malfunctions as soon as practicable after their occurrence in order to minimize excess emissions of hazardous air pollutants (HAP); and
- Reduce the reporting burden associated with periods of startup, shutdown and malfunction (including corrective action taken to restore malfunctioning process and air pollution control equipment to its normal or usual manner of operation).

A more detailed summary of the regulatory background and summary of requirements for preparation and use of a startup, shutdown and malfunction (SSM) plan (SSM Plan) is contained in the document "Guidance for Preparation of Startup, Shutdown and Malfunction Plans", Waste Management, Inc., October 27, 2003 for guidance and instructions for completing and customizing the plan.

The Berman Road Landfill is an existing affected source under the Maximum Achievable Control Technology (MACT) rule for MSW landfills. Berman Road Landfill is subject to the MSW Landfill New Source Performance Standards (NSPS). Because it is NSPS applicable, it is also subject to the National Emission Standards for Hazardous Air Pollutants (NESHAP) for MSW Landfills. As such, a SSM Plan is required to be prepared and implemented for this landfill site by January 16, 2004 and this SSM Plan meets or exceeds this requirement.

The management of the Berman Road Landfill fully understands and acknowledges the SSM Plan requirements of the MACT rule. This SSM Plan has been developed to specifically address these requirements as summarized above.

2.2 Description Of SSM Plan

This SSM Plan has been divided into three major sections comprising the major elements related to startup, shutdown and/or malfunction of a landfill gas (LFG) collection and control system (GCCS) at a MSW landfill. Malfunction events are distinct events when the GCCS is not operating in accordance with NSPS/EG requirements and which result, or have the potential to result, in an exceedance of one or more emission limitations or operational standards under the NSPS/EG. Startup and shutdown events are generally planned events associated with system repair, maintenance, testing and upgrade and may or may not be related to or occur in association with a malfunction of the GCCS.

2.3 Site Equipment Subject To This SSM Plan

The following components of the GCCS are subject to this SSM Plan:

Collection wells and other collectors
Lateral and header extraction piping
LFG mover equipment
Temperature monitoring and recording equipment
Flow monitoring and recording equipment
Enclosed Flares
Open, Unenclosed Flare
Leachate EVAP Systems
Condensate Knockout/Collection

2.4 Site Equipment NOT Subject To This SSM Plan

The following components of the GCCS are NOT subject to this SSM Plan:

Passive, Solar Flares

Berman Road Landfill is not considering the passive, solar flares as part of this SSM Plan because these devices are not used as part of the GCCS for compliance with NSPS requirements. The passive, solar flares are used for temporary control of newly installed landfill gas wells to control the odor emitted from them prior to final connection to the active GCCS. Prior to connection to the active GCCS, the subject wells are not considered NSPS applicable, therefore, the passive, solar flares would not be NSPS or NESHAP applicable.

3 Startup/Shutdown Plan

This section details procedures for the startup of the GCCS to ensure that, at all times, good safety and air pollution control practices are used for minimizing emissions to the levels required by the relevant standards.

Pursuant to the requirements of the NSPS/EG for MSW landfills, a GCCS must be installed and operated when the landfill exceeds a threshold of 50 Megagrams (Mg)/year nonmethane organic compounds (NMOC) and meets all the applicable criteria for a controlled landfill.

3.1 How to Identify a GCCS Startup / Shutdown Event

The regulatory definition of "startup" reads as follows:

"Startup means the setting in operation of an affected source or portion of an affected source for any purpose." (§63.2)

The regulatory definition of “shutdown” reads as follows:

“**Shutdown** means the cessation of an affected source or portion of an affected source or portion of an affected source for any purpose.” (§63.2)

GCCS startup operations and shutdown events generally include startup or shutdown of gas mover equipment, LFG control devices and any ancillary equipment that could affect the operation of the GCCS (e.g., power supply, air compressors, etc.). This section details procedures for the startup and/or shutdown of the GCCS to ensure that, at all times, good safety and air pollution control practices are used for minimizing emissions to the levels required by the relevant standards.

The following list includes events that may necessitate a shutdown of the GCCS at a MSW Landfill. This list should not be considered exhaustive.

Table 3-1—Potential Events Necessitating Shutdown of the GCCS

Control Device Maintenance, Repair or Cleaning
Addition of New GCCS Components
Extraction Well Raising
Vertical well(s), horizontal collector(s) isolation/shutdown for well/landfill cover maintenance and construction
Movement of LFG Piping to Accommodate New Components or Filling Operations
Source Testing
Gas Mover Equipment Maintenance, Repair or Cleaning
Gas Processing Equipment Maintenance, Repair or Cleaning
Ancillary Equipment (e.g., compressors, etc.) Maintenance, Repair or Cleaning
New Equipment Testing and Debugging
Shutdown and Subsequent Startup to Address Malfunctions or Other Occurrences
Planned Electrical Outages
Horizontal collectors buildup of liquid (“watered out”)
Gas collection system header buildup of liquid (“watered out”)

3.2 Actions To Take When the GCCS is Started-Up

The following provides a summary of typical response actions for startup of the GCCS.

3.2.1 Gas Mover and Collection System

The following activities may have the potential to emit regulated air pollutants to the atmosphere during startup of the collection system portion of GCCS: (1) purging of gases trapped within piping system prior to normal operation; (2) repair of system leaks discovered during startup and (3) all other activities after construction of the system but prior to fulltime operation, which could release HAPs from the collection system. These activities would be subject to the Startup Plan portion of the SSM Plan.

During such activities, work shall progress such that air emissions are minimized to the greatest extent possible by:

- Temporarily capping pipes venting gas if such capping does not impact safety or the effective construction of the system.

- Minimizing surface area allowing gas to emit to the atmosphere to the extent that it does not impact safety or the effective construction of the system.
- Ensuring that other parts of the system, not impacted by the activity, are operating in accordance with the applicable requirements of NSPS/EG.
- Limiting the purging of piping to as short duration as possible to ensure safe combustion of the gas in the control device.

GCCSs, once installed, are “closed” systems designed to prevent the uncontrolled release of LFG to the atmosphere. The network of piping installed at the site connects each extraction point with the control device(s) with no open vents located anywhere in the collection system.

Portions of collection systems or individual extraction points may be isolated by valves installed in the system from time to time and subsequently opened. Opening these valves shall not be considered a startup, unless such an activity causes the venting of gas to the atmosphere. If the activity results in emissions to the atmosphere, the actions listed above shall be followed.

The operation of the collection system, once installed, shall be consistent with the provisions of NSPS/EG as well as the GCCS Design Plan, which has been developed, and approved for the facility.

3.2.2 Control Device(s):

Personnel shall follow the procedures as identified below when starting the respective control devices. Control devices operating at MSW landfills normally undergo planned startups. However, flare systems are designed for unattended operation. There are instances when the flare system will shutdown and automatically restart. The shutdown may occur when there is a brief interruption of gas flow to the flare. These shutdown events are followed by an automatic startup sequence as described in the standard operating procedures listed below and incorporated by reference as part of this SSM Plan.

The flare temperature and/or flow recorders will document significant decreases in temperature and/or flow measurements followed by an almost immediate increase back to normal ranges whenever the automatic shutdown/startup sequence occurs. Documentation of the date, time and duration of these automatic shutdown/startup events is contained in the flare temperature and/or flow charts. In addition, there are no actions that need to be taken to affect the shutdown/startup sequence in these instances; therefore, these activities do not need to be documented beyond the information already contained on chart recorders. Documentation of automatic shutdown/startup events will be included in the semi-annual reports.

3.3 Actions To Take When The GCCS Is Shutdown

3.3.1 Collection System

GCCSs, once installed, are “closed” systems designed to prevent the uncontrolled release of LFG to the atmosphere. The network of piping installed at the site connects each extraction point with the control device(s) with no open vents located anywhere in the collection system.

Portions of collection systems or individual extraction points may be isolated by valves installed in the system from time to time. Closing these valves shall be considered a shutdown, only when such an activity causes an exceedance of the provisions of NSPS/EG and/or any subsequent approvals of alternatives in the facility’s GCCS Design Plan or approved variances issued thereafter. The parameters used to determine if there has been an exceedance that would trigger the need for implementing the SSM Plan would be the monthly well monitoring parameters of pressure (>0 in Hg). An individual well may have a differing monitoring parameter that will be documented in the NSPS GCCS Plan or approved in a Permit. These values will be used in place of those listed above. If one or more well exceed one or more of these parameters, then the SSM Plan will be invoked. Because the closing of valves usually occur

when multiple wells are closed or isolated by a header or lateral valve, these occurrences will be considered “events” and documented with by completing a single **SSM Report Form** (Appendix B), not individual SSM Report Forms for each well affected by the shutdown. The well(s) that are part of the “event” will normally be returned to services less than 5 days after isolation of multiple wells or closing of individual wells.

3.3.2 Control Device(s):

Personnel shall follow the procedures as identified below when shutting down the respective control devices. Control devices operating at MSW landfills normally undergo planned shutdown for the various events listed above. Shutdowns for equipment malfunction or breakdown should be addressed in the malfunction plan. Control device shutdown guidance are described in the standard operating procedures in the flare Operation & Maintenance (O&M) Manual incorporated as part of this SSM Plan, as listed below. In addition to the procedures outline in the O&M Manual, the flare can be shutdown safely by turning off power to the control panel. Power can be turned off by pressing the large red button on the control panel or by throwing the main power breaker switch for the control panel.

Table 3-2—Startup / Shutdown Guidance Procedure Reference

Device Name	Operations manual, notes, report, etc.	
	Title	Page(s)
Enclosed Flare – Unit# 1776	LFG Specialties Enclosed Flare System O&M Manual	Section 2.0 – Operation Sub-Section
Enclosed Flare – Unit# 1698	LFG Specialties Enclosed Flare System O&M Manual	Section 2.0 – Operation Sub-Section
Open, Unenclosed Flare – Unit# 1495	LFG Specialties Utility Flare System O&M Manual	Section 2.0 – Operation Sub-Section
Leachate EVAP System – Unit# 3016 - STARTUP	LFG Specialties Leachate Evaporator System O&M Manual	Section 1.0 –Sub-Section II – Operation, Pages viii-xii
Leachate EVAP System – Unit# 3016 - SHUTDOWN	LFG Specialties Leachate Evaporator System O&M Manual	Section 1.0 –Sub-Section II – Sequence of Operations for Flame Supervisory System; Step 7
Leachate EVAP System – Unit# 3004IM – STARTUP	LFG Specialties Leachate Evaporator System O&M Manual	Section 1.0 –Sub-Section II – Operation, Pages viii-xii
Leachate EVAP System – Unit# 3004IM – SHUTDOWN	LFG Specialties Leachate Evaporator System O&M Manual	Section 1.0 –Sub-Section II – Sequence of Operations for Flame Supervisory System; Step 7

3.4 What to Record for All Startup / Shutdown Events

The operator shall record the following information on the attached **SSM Report Form** (Appendix B), which should be retained in the landfill operating record for five (5) years:

- The date and time the startup/shutdown occurred.
- The duration of the startup/shutdown.
- The actions taken to effect the startup/shutdown.
- Whether procedures in this SSM Plan were followed. If the procedures in the SSM Plan were not followed, a **SSM Plan Departure Report Form** (Appendix B) must also be completed.
- If an applicable emission limitation was exceeded, a description of the emission standard that was exceeded.

3.5 Whom to Notify at the Facility in Case of a Startup/Shutdown Event

- John Van Gessel, Vice President and Assistant Secretary; Mike Stallard, District Manager or Miguel Delgado, Engineering Manager should be verbally notified within a reasonable timeframe of the startup/shutdown.
- John Van Gessel, Vice President and Assistant Secretary; Mike Stallard, District Manager or Miguel Delgado, Engineering Manager should be verbally notified within a reasonable timeframe of progress of the diagnosis and resolution of the startup/shutdown.
- John Van Gessel, Vice President and Assistant Secretary; Mike Stallard, District Manager and Miguel Delgado, Engineering Manager should be verbally notified when the alternative timeframe for startup/shutdown has been established if it is outside of the timeframes currently allowed by the NSPS/EG for particular compliance elements.
- The **SSM Report Form** should be initially prepared upon startup/shutdown, or discovery of an automatic startup/shutdown and implementation of the SSM Plan. The form should be finalized by the operator on duty upon successful implementation of the SSM Plan and submitted to the John Van Gessel, Vice President and Assistant Secretary; Mike Stallard, District Manager or Miguel Delgado, Engineering Manager. The original form should be retained in the landfill operating record for five (5) years.

3.6 What to Report for a Startup/Shutdown Event

- If the actions taken during the startup/shutdown **were consistent** with this SSM Plan, file the necessary information in your semi-annual SSM report (*within 30 days following the end of each 6-month period*) with the following information included:
 1. Name and title of John Van Gessel, Vice President and Assistant Secretary; Mike Stallard, District Manager or Miguel Delgado, Engineering Manager;
 2. Certifying signature of the owner/operator or other responsible official; and
 3. Statement that the actions taken during the startup or shutdown were consistent with the SSM Plan.

- If the actions taken during a startup **were not consistent** with this SSM Plan, the John Van Gessel, Vice President and Assistant Secretary; Mike Stallard, District Manager or Miguel Delgado, Engineering Manager must report the actions taken to the enforcing authority by telephone or facsimile transmission within two (2) working days after the startup or shutdown. A letter must then be sent to the enforcing authority within seven (7) working days after the subject startup or shutdown. The letter should be sent by certified or registered mail or overnight delivery service and must include the following information:
 1. Name and title of John Van Gessel, Vice President and Assistant Secretary; Mike Stallard, District Manager or Miguel Delgado, Engineering Manager;
 2. Certifying signature of the owner/operator or other responsible official (Note that “responsible official” has the same meaning as under the Title V permitting program. See previous corporate guidance on this topic.);
 3. Detailed explanation of the circumstances of the start/shutdown;
 4. The reasons the SSM Plan was not adequate; and whether any excess emissions and/or parameter monitoring exceedances is believed to have occurred during the event.
 5. A copy of the **SSM Plan Departure Report Form**.

- Note: If the revisions to the SSM Plan alter the scope of the process activities at Berman Road Landfill or otherwise modify the applicability of any emission limit, work practice requirement, or other requirement in the MACT rule and/or the NSPS/EG, the revised SSM Plan is not effective until written notice has been provided to the permitting authority describing the SSM Plan revision(s).

4 Malfunction Plan

4.1 How to Identify a GCCS Malfunction

The regulatory definition of “malfunction” reads as follows:

“Malfunction means any sudden, infrequent and not reasonably preventable failure of air pollution control and monitoring equipment, process equipment, or a process to operate in a normal or usual manner which causes, or has the potential to cause, the emission limitations in an applicable standard to be exceeded. Failures that are caused in part by poor maintenance or careless operation are not malfunctions.” (§63.2, revised 5/30/03)

The following list includes events that may constitute a malfunction of the GCCS at Berman Road Landfill. The cause of these events should be investigated immediately in order to determine the best course of action to correct the malfunction. Each of these malfunctions could have multiple causes that need to be evaluated and possibly considered. It is the intent of this SSM Plan to include all possible causes for the specific malfunction events. Common malfunction events for LFG collection and control systems are listed in Table 4-1.

Table 4-1—Potential Malfunction Events

Possible Malfunction	Section
Loss of LFG Flow/Gas Mover Malfunction	4.3
Loss of Electrical Power	4.4
Low Temperature Conditions at Control Device	4.5
Loss of Flame at the Control Device	4.6
Malfunction of Flow Measuring/Recording Device	4.7
Malfunction of Temperature Measuring/Recording Device	4.8
Collection Well and Pipe Failures	4.9
Other Control Device Malfunctions	4.10
Malfunction of Field Monitoring Equipment	4.11
Buildup of Liquid in Piping	4.12

For one of these occurrences to be considered a malfunction that is required to be addressed by this SSM Plan, it must result in, or have the potential to result in, an exceedance of one or more of the NSPS/EG operational and compliance requirements or the provisions of the MACT rule (e.g., exceedance, reading outside of required operational range, etc). The following list constitutes the possible exceedances of the New Source Performance Standards (NSPS) for MSW landfills and/or the state/local emission guidelines (EG) rule that could occur due to a malfunction of GCCS, thereby necessitating implementation of this SSM Plan:

**Table 4-2— Potential Emission Limitation Exceedances
Caused by Malfunction Events**

GCCS downtime of greater than 5 days (if alternative timeframe has not been established)
Free venting of collected LFG without control for greater than one hour
Control device temperatures excursions in which 3-hour block average is less than established minimum temperature
Downtime for temperature monitoring and/or recording equipment of greater than 15 minutes (if alternative timeframe has not been established)
Any downtime for LFG flow monitoring and/or recording equipment (if alternative timeframe has not been established)
Reserved for modifications or reinterpretations of the NSPS rule by the U.S. EPA or state/local jurisdiction or state/local requirements that are in addition to or more stringent than NSPS/EG

If the occurrence does not result in an exceedance of an applicable emission limitation, or does not have the potential to result in such an exceedance, then **it is not required to be corrected in accordance with this SSM Plan**, although use of the plan may still be advisable. Malfunctions should be considered actionable under this SSM Plan whether discovered by the MSW landfill owner or operator during normal operations or by a regulatory agency during compliance inspections.

The operator should follow all the corrective action, notification, record keeping and reporting procedures described herein in case of malfunction of the GCCS.

4.2 Actions to Take When The GCCS Malfunctions—All Malfunctions

- Determine whether the malfunction has caused an exceedance, or has the potential to cause an exceedance, of any applicable emission limitation contained in the NSPS/EG or MACT.
- Identify whether the malfunction is causing or has caused excess emissions to the atmosphere. If excess emissions are occurring, take necessary steps to reduce emissions to the maximum extent possible using good air pollution control practices and safety procedures.
- Contact the site John Van Gessel, Vice President and Assistant Secretary; Mike Stallard, District Manager or Miguel Delgado, Engineering Manager immediately and proceed with the malfunction diagnosis and correction procedures described in Appendix A (“Common Causes and Response Actions for GCCS Malfunctions”) for each specific malfunction.
- Site-specific malfunction and/or troubleshooting procedures are contained in the documents or appendices referenced below. Personnel shall follow these guidance procedures when addressing a malfunction of a collection system or control device.

Table 4-3—Malfunction Guidance Procedure Reference

Control Device ID	Operations manual, notes, report, etc.	
	Title	Page(s)
Enclosed Flare – Unit# 1776	LFG Specialties Enclosed Flare System O&M Manual	Section 2.0 – Operation Sub-Section; Steps 7-10
Enclosed Flare – Unit# 1698	LFG Specialties Enclosed Flare System O&M Manual	Section 2.0 – Operation Sub-Section; Steps 7-10
Open, Unenclosed Flare – Unit# 1495	LFG Specialties Utility Flare System O&M Manual	Section 2.0 – Operation Sub-Section; Steps 5-11
Leachate EVAP System – Unit# 3016	LFG Specialties Leachate Evaporator System O&M Manual	Section 1.0 –Sub-Section II –
Leachate EVAP System – Unit# 3004IM	LFG Specialties Leachate Evaporator System O&M Manual	Section 1.0 –Sub-Section II –

- If the procedures in this SSM Plan do not address or adequately address the malfunction that has occurred, the operator should attempt to correct the malfunction with the best resources available. John Van Gessel, Vice President and Assistant Secretary; Mike Stallard, District Manager or Miguel Delgado, Engineering Manager should be notified of this situation immediately. Complete a **SSM Plan Departure Report Form** (Appendix B) as discussed in Section 4.14. The SSM Plan must be updated to better address this type of malfunction.
- Notify the John Van Gessel, Vice President and Assistant Secretary; Mike Stallard, District Manager or Miguel Delgado, Engineering Manager of the progress of the diagnosis and correction procedures and status of the malfunction as soon as practicable.
- If the GCCS malfunction cannot be corrected within the time frame specified in the NSPS/EG, notify the John Van Gessel, Vice President and Assistant Secretary; Mike Stallard, District Manager or Miguel Delgado, Engineering Manager and proceed to shutdown the control device and/or the process(es) venting to the control device, if this has not already automatically occurred.
- If the GCCS malfunction cannot be corrected within the time frame allowed by the NSPS/EG rule for each specific malfunction, define the appropriate alternative timeframe for corrective action that is reasonable for the type of repair or maintenance that is required to correct the malfunction.
- If the GCCS malfunction cannot be corrected within alternative timeframe for corrective action specified above, notify the John Van Gessel, Vice President and Assistant Secretary; Mike Stallard, District Manager or Miguel Delgado, Engineering Manager and conduct the appropriate record keeping and reporting required for deviations of the MACT rule and Title V permit.
- Once the malfunction is corrected, notify the John Van Gessel, Vice President and Assistant Secretary; Mike Stallard, District Manager or Miguel Delgado, Engineering Manager as soon as the system is operational.

- Complete the **SSM Plan Departure Report Form** (Appendix B) after the malfunction diagnosis and correction procedures are completed.
- If the procedures in this SSM Plan do not address or adequately address the malfunction that has occurred, the operator should note the circumstances and the actual steps taken to correct the malfunction in the **SSM Report Form** (Appendix B). This SSM Plan will need to be revised based on this information, as described in Section 4.13 below.
- Follow procedures in Sections 4.12 through 4.14, as appropriate, to adequately document, notify and report the malfunction and corrective action.

4.3 Loss of LFG Flow/Gas Mover Malfunction

- Follow the procedures in Section 4.2, above: **What to Do When the GCCS Malfunctions—All Malfunctions.**
- Check to see if the control device has shutdown. If control device has shutdown, make sure that gas mover equipment has shutdown to prevent free venting of LFG. Attempt to restart control device to determine if system will remain operational.
- Conduct diagnostic procedures to identify the cause of the malfunction. Potential causes and response actions for this type of malfunction are listed in Appendix A.
- If the malfunction cannot be corrected within 5 days, follow the procedures under Section 4.2 above to establish an appropriate alternative timeframe for corrective action and complete necessary record keeping and reporting if the malfunction cannot be corrected within the established timeframe.

4.4 Loss of Electrical Power

- Follow also the procedures in Section 4.2, above: **What to Do When the GCCS Malfunctions—All Malfunctions.**
- Conduct diagnostic procedures to identify the cause of the malfunction. Potential causes and response actions for this type of malfunction are listed in Appendix A.
- If the malfunction cannot be corrected within the time frame allowed by the NSPS/EG rule, follow the procedures under Section 4.2 above to establish an appropriate alternative timeframe for corrective action and complete necessary record keeping and reporting if malfunction cannot be corrected within the established timeframe.

4.5 Low Temperature Conditions at the Control Device

- Follow also the procedures in Section 4.2, above: **What to Do When the GCCS Malfunctions—All Malfunctions.**
- Check to see if the control device has shutdown. If control device has shutdown, make sure that gas mover equipment has shutdown to prevent free venting of LFG. Attempt to restart control device to determine if system will remain operational.
- Conduct diagnostic procedures to identify the cause of the malfunction. Potential causes and response actions for this type of malfunction are listed in Appendix A.

- If the malfunction causes an exceedance of the control device's minimum temperature for a 3-hour block average, follow the procedures under Section 4.2 above to establish an appropriate alternative timeframe for corrective action and complete necessary record keeping and reporting if the malfunction cannot be corrected within the established timeframe.
- If the malfunction causes the GCCS to go off-line and cannot be corrected within the time frame allowed by the NSPS/EG rule, follow the procedures under Section 4.2 above to establish an appropriate alternative timeframe for corrective action and complete necessary record keeping and reporting if the malfunction cannot be corrected within the established timeframe.

4.6 Loss of Flame at the Control Device

- Follow also the procedures in Section 4.2, above: **What to Do When the GCCS Malfunctions—All Malfunctions.**
- Check to see if the control device has shutdown. If control device has shutdown, make sure that gas mover equipment has shutdown to prevent free venting of LFG. Attempt to restart control device to determine if system will remain operational.
- If system will not restart, follow also the procedures in Section 4.3, above: **Loss of LFG Flow.**
- Conduct diagnostic procedures to identify the cause of the malfunction. Potential causes and response actions for this type of malfunction are listed in Appendix A.
- If the malfunction cannot be corrected within the time frame allowed by the NSPS/EG rule, follow the procedures under Section 4.2 above to establish an appropriate alternative timeframe for corrective action and complete necessary record keeping and reporting if the malfunction cannot be corrected within the established timeframe.

4.7 Malfunctions of Flow Monitoring/Recording Device

- Follow the procedures in Section 4.2, above: **What to Do When the GCCS Malfunctions—All Malfunctions.**
- Conduct diagnostic procedures to identify the cause of the malfunction. Potential causes and response actions for this type of malfunction are listed in Appendix A.
- If the malfunction cannot be corrected in the time frame allowed by the NSPS/EG rule, follow the procedures under Section 4.2 above to establish an appropriate alternative timeframe for corrective action and complete necessary record keeping and reporting if the malfunction cannot be corrected within the established timeframe.

4.8 Malfunctions of Temperature Monitoring/Recording Device

- Follow the procedures in Section 4.2, above: **What to Do When the GCCS Malfunctions—All Malfunctions.**
- Conduct diagnostic procedures to identify the cause of the malfunction. Potential causes and response actions for this type of malfunction are listed in Appendix A.

- If the malfunction cannot be corrected within 15 minutes, follow the procedures under Section 4.2 above to establish an appropriate alternative timeframe for corrective action and complete necessary record keeping and reporting if the malfunction cannot be corrected within the established timeframe.

4.9 Collection Well and Pipe Failures

- Follow the procedures in Section 4.2, above: **What to Do When the GCCS Malfunctions—All Malfunctions.**
- Follow also the procedures in Section 4.3, above: **Loss of Flow/Gas Mover Malfunction.**
- Conduct diagnostic procedures to identify the cause of the malfunction. Potential causes and response actions for this type of malfunction are listed in Appendix A.
- If the malfunction causes the entire GCCS to go off-line and cannot be corrected within 5 days, follow the procedures under Section 4.2 above to establish an appropriate alternative timeframe for corrective action and complete necessary record keeping and reporting if the malfunction cannot be corrected within the established timeframe.

4.10 Other Control Device Malfunctions

- Follow also the procedures in Section 4.2, above: **What to Do When the GCCS Malfunctions—All Malfunctions.**
- Check to see if the control device has shutdown. If control device has shutdown, make sure that gas mover equipment has shutdown to prevent free venting of LFG. Attempt to restart control device to determine if system will remain operational.
- Conduct diagnostic procedures to identify the cause of the malfunction. Potential causes and response actions for this type of malfunction are listed in Appendix A.
- If the malfunction causes an exceedance of the control device's minimum temperature for a 3-hour block average, follow the procedures under Section 4.2 above to establish an appropriate alternative timeframe for corrective action and complete necessary record keeping and reporting if the malfunction cannot be corrected within the established timeframe.
- If the malfunction causes the entire GCCS to go off-line and cannot be corrected within 5 days, follow the procedures under Section 4.2 above to establish an appropriate alternative timeframe for corrective action and complete necessary record keeping and reporting if the malfunction cannot be corrected within the established timeframe.

4.11 Malfunctions of Field Monitoring Equipment

- Follow the procedures in Section 4.2, above: **What to Do When the GCCS Malfunctions—All Malfunctions.**
- Verify that malfunction of monitoring equipment will cause a deviation of the NSPS/EG requirements for wellhead and/or surface emissions monitoring.
- Conduct diagnostic procedures to identify the cause of the malfunction.
- Repair the device or obtain replacement device to complete the monitoring as required by the NSPS/EG.

- Conduct proper calibration procedures before use of the device for NSPS/EG compliance monitoring.
- If the malfunction cannot be corrected so that the monitoring equipment can be used for the purposes required by the NSPS/EG rule, follow the procedures under Section 4.2 above to establish an appropriate alternative timeframe for corrective action and complete necessary record keeping and reporting if the malfunction cannot be corrected within the established timeframe.

4.12 Buildup of Liquid in Piping

- Follow the procedures in Section 4.2, above: **What to Do When the GCCS Malfunctions—All Malfunctions.**
- Verify that blockage resulting from the build-up of liquid will cause a deviation of the NSPS/EG requirements for operation of the control devices by restricting flow resulting in low operating temperature.
- Verify that blockage resulting from the build-up of liquid will cause a deviation of the NSPS/EG requirements for operation of the collection system by restricting flow resulting in positive pressures at the wellheads.
- Conduct diagnostic procedures to identify the cause and the location of the build-up of liquid.
- Follow shutdown procedures for the gas mover and control devices outlined in Section 4. Allow condensate to drain, or manually remove excess condensate from the piping via use of water pumps.
- Follow startup procedures for the gas mover and control devices outlined in Section 3.
- Assess whether liquid removal remedied the low flow conditions.

4.13 What to Record for a Malfunction

The operator must record the following information on the attached **SSM Report Form**, which must be retained in the landfill operating record for five (5) years:

- The date and time the malfunction occurred.
- The duration of the malfunction.
- A description of the affected equipment.
- The cause or reason for the malfunction (if known).
- The actions taken to correct the malfunction (checklist).
- Whether the procedures in this SSM Plan were followed. If the procedures in the plan were not followed, a **SSM Plan Departure Report Form** must also be completed.
- A description of the emission standard that was exceeded or had the potential to be exceeded.

4.14 Whom to Notify at the Facility in Case of a Malfunction

- John Van Gessel, Vice President and Assistant Secretary; Mike Stallard, District Manager or Miguel Delgado, Engineering Manager shall be notified immediately of the malfunction.
- John Van Gessel, Vice President and Assistant Secretary; Mike Stallard, District Manager or Miguel Delgado, Engineering Manager shall be notified within a reasonable timeframe of progress of the diagnosis and corrective action of the malfunction.
- John Van Gessel, Vice President and Assistant Secretary; Mike Stallard, District Manager or Miguel Delgado, Engineering Manager shall be notified when the alternative timeframe for corrective action has been established if it is outside of the timeframes currently allowed by the NSPS/EG for particular compliance elements.
- John Van Gessel, Vice President and Assistant Secretary; Mike Stallard, District Manager or Miguel Delgado, Engineering Manager shall be notified if the malfunction cannot be corrected within the timeframe allowed by the NSPS rule or the alternate timeframe established under this SSM Plan. Notification should also occur if the current SSM Plan had not addressed the malfunction.
- The **SSM Report Form** shall be initially prepared upon discovery of the malfunction and implementation of the SSM Plan. The form shall be finalized by the operator on duty upon successful implementation of the SSM Plan and submitted to John Van Gessel, Vice President and Assistant Secretary; Mike Stallard, District Manager or Miguel Delgado, Engineering Manager. The original form must be retained in the landfill operating record for five (5) years.

4.15 What to Report for a Malfunction Event

- If the actions taken during the malfunction **were consistent** with this SSM Plan and the malfunction resulted or had the potential to result in an exceedance of an applicable emission standard, file the necessary information in your semi-annual SSM report (*within 30 days following the end of each 6-month period*) with the following information included:
 1. Name and title of John Van Gessel, Vice President and Assistant Secretary; Mike Stallard, District Manager or Miguel Delgado, Engineering Manager;
 2. Certifying signature of the owner/operator or other responsible official (Note that "responsible official" has the same meaning as under the Title V permitting program. See previous corporate guidance on this topic.); and
 3. Statement that the actions taken during the malfunction were consistent with the SSM Plan.
- If the actions taken during a malfunction **were not consistent** with this SSM Plan and the malfunction resulted in or had the potential to result in an exceedance of an applicable emission standard, (see items listed under Step 1 above), John Van Gessel, Vice President and Assistant Secretary; Mike Stallard, District Manager or Miguel Delgado, Engineering Manager must report the actions taken to the enforcing authority by telephone or facsimile (FAX) transmission within two (2) working days after commencing the actions that were inconsistent with the plan. A letter must then be sent to the enforcing authority within seven (7) working days after the malfunction. The letter should be sent by certified or registered mail-or overnight delivery service and must include the following information:
 1. Name and title of John Van Gessel, Vice President and Assistant Secretary; Mike Stallard, District Manager or Miguel Delgado, Engineering Manager;
 2. Certifying signature of the owner/operator or other responsible official (Note that "responsible official" has the same meaning as under the Title V permitting program. See previous corporate guidance on this topic.);

3. Detailed explanation of the circumstances of the malfunction;
 4. The reasons the SSM Plan was not adequate; and
 5. Whether any excess emissions and/or parameter monitoring exceedances is believed to have occurred during the event.
 6. Prepare and include **SSM Plan Departure Report Form**.
- If the actions taken during the malfunction **were not consistent** with this SSM Plan, the John Van Gessel, Vice President and Assistant Secretary; Mike Stallard, District Manager or Miguel Delgado, Engineering Manager at the landfill must:
 1. Revise the SSM Plan within 45 days after the malfunction to include procedures for operating and maintaining the GCCS during similar malfunction events.
 2. Include the revised SSM Plan in the semi-annual report (within 30 days following the end of each 6-month period).

Note: If the revisions to the SSM Plan alter the scope of the process activities at Berman Road Landfill or otherwise modify the applicability of any emission limit, work practice requirement, or other requirement in the MACT rule and/or the NSPS/EG, the revised SSM Plan is not effective until written notice has been provided to the permitting/enforcing authority describing the SSM Plan revision(s).

APPENDIX A

Common Causes and Response Actions for GCCS Malfunctions

(Appendix A represents a summary of possible causes and response actions for GCCS malfunctions. The list is not considered to be exhaustive. The list of response actions is not intended to be a sequence of events that are to be implemented in order. Certain malfunction incidents may or may not be associated with the listed “common causes” nor will the “common response actions” be appropriate in all instances. Site-specific evaluation of the malfunctions and development of specific response actions is recommended in all cases.)

EQUIPMENT	PURPOSE	MALFUNCTION EVENT	COMMON CAUSES	TYPICAL RESPONSE ACTIONS
LFG Collection and Control System				
Blower or Other Gas Mover Equipment	Applies vacuum to wellfield to extract LFG and transport to control device	Loss of LFG Flow/Blower Malfunction	<ul style="list-style-type: none"> -Flame arrestor fouling/deterioration -Automatic valve problems -Blower failure (e.g., belt, motor, impeller, coupling, seizing, etc.) -Loss of power -Extraction piping failure -Condensate knock-out problems -Extraction piping blockages 	<ul style="list-style-type: none"> -Repair breakages in extraction piping -Clean flame arrestor -Repair blockages in extraction piping -Verify automatic valve operation, compressed air/nitrogen supply -Notify power utility, if appropriate -Provide/utilize auxiliary power source, if necessary -Repair Settlement in Collection Piping - Repair Blower -Activate back-up blower, if available -Clean knock-up pot/demister -Drain knock-out pot
Extraction Wells and Collection Piping	Conduits for extractions and movement of LFG flow	Collection well and pipe failures	<ul style="list-style-type: none"> -Break/crack in header or lateral piping -Leaks at wellheads, valves, flanges, test ports, seals, couplings, etc. -Collection piping blockages -Problems due to settlement (e.g. pipe separation, deformation, development of low points) 	<ul style="list-style-type: none"> -Repair leaks or breaks in lines or wellheads -Follow procedures for loss of LFG flow/blower malfunction -Repair blockages in collection piping -Repair settlement in collection piping -Re-install, repair, or replace piping -Review waste types, age of waste, etc.

EQUIPMENT	PURPOSE	MALFUNCTION EVENT	COMMON CAUSES	TYPICAL RESPONSE ACTIONS
LFG Collection and Control System				
Blower or Other Gas Mover Equipment And Control Device	Collection and control of LFG	Loss of electrical power	<ul style="list-style-type: none"> - Force majeure/Act of God (e.g., lightning, flood, earthquake, etc.) -Area-wide or local blackout or brown-out -Interruption in service (e.g. blown service fuse) -Electrical line failure -Breaker trip -Transformer failure -Motor starter failure/trip -Overdraw of power -Problems in electrical panel -Damage to electrical equipment from on-site operations 	<ul style="list-style-type: none"> -Check/reset breaker -Check/repair electrical panel components -Check/repair transformer -Check/repair motor starter -Check/repair electrical line -Test amperage to various equipment -Contact electricity supplier -Contact/contract electrician -Provide auxiliary power (if necessary)
LFG Control Device	Combusts LFG	Low temperature conditions at control device	<ul style="list-style-type: none"> -Problems with temperature - monitoring equipment -Problems/failure of -thermocouple and/or thermocouple wiring -Change of LFG flow -Change of LFG quality -Problems with air louvers -Problems with air/fuel controls -Change in atmospheric conditions 	<ul style="list-style-type: none"> -Check/repair temperature monitoring equipment -Check/repair thermocouple and/or wiring -Follow procedures for loss of flow/blower malfunction -Check/adjust louvers -Check/adjust air/fuel controls
LFG Control Device	Combusts LFG	Loss of Flame	<ul style="list-style-type: none"> -Problems/failure of thermocouple -Loss/change of LFG flow -Loss/change of LFG quality -Problems with air/fuel controls -Problems/failure of flame sensor -Problems with temperature monitoring equipment 	<ul style="list-style-type: none"> -Check/repair temperature monitoring equipment -Check/repair thermocouple -Follow procedures for loss of flow/blower malfunction -Check/adjust air/fuel controls -Check/adjust/repair flame sensor -Check/adjust LFG collectors
Flow Monitoring/Recording Device	Measures and records gas flow from collection system to control	Malfunctions of Flow Monitoring/Recording Device	<ul style="list-style-type: none"> -Problems with orifice plate, pitot tube, or other in-line flow measuring device -Problems with device controls and/or wiring -Problems with chart recorder 	<ul style="list-style-type: none"> -Check/adjust/repair flow measuring device and/or wiring -Check/repair chart recorder -Replace paper in chart recorder

EQUIPMENT	PURPOSE	MALFUNCTION EVENT	COMMON CAUSES	TYPICAL RESPONSE ACTIONS
LFG Collection and Control System				
Temperature Monitoring/ Recording Device	Monitors and records combustion temperature of enclosed combustion device	Malfunctions of Temperature Monitoring/Recording Device	<ul style="list-style-type: none"> -Problems with thermocouple -Problems with device controls and/or wiring -Problems with chart recorder 	<ul style="list-style-type: none"> -Check/adjust/repair thermocouple -Check/adjust/repair controller and/or wiring -Check/adjust/repair electrical panel components -Check/repair chart recorder -Replace paper in chart recorder
Control Device	Combusts LFG	Other Control Device Malfunctions	<ul style="list-style-type: none"> -Control device smoking (i.e. visible emissions) -Problems with flare insulation -Problems with pilot light system -Problems with air louvers -Problems with air/fuel controllers -Problems with thermocouple -Problems with burners -Problems with flame arrester -Alarmed malfunction conditions not covered above -Unalarmed conditions discovered during inspection not covered above 	<ul style="list-style-type: none"> -Site-specific diagnosis procedures -Site-specific responses actions based on diagnosis -Open manual louvers -Clean pitot orifice -Clean/drain flame arrester -Refill propane supply -Check/repair pilot sparking system
Collection Piping	Conduit movement of LFG flow	Blockage of LFG Flow	<ul style="list-style-type: none"> -Collection piping blockages due to build-up of liquid -Problems due to settlement (e.g. pipe separation, deformation, development of low points) 	<ul style="list-style-type: none"> -Follow procedures for loss of LFG flow/blower malfunction -Repair blockages in collection piping -Repair settlement in collection piping -Re-install, repair or replace piping

APPENDIX B
SSM Plan Reporting Forms

Type of Event	Military Time		Duration (hours)	Event Code (see back of form)	SCP* Followed?	
	Date/Time Start	Date/Time End			Yes	No**
<input type="checkbox"/> Startup						
<input type="checkbox"/> Shutdown						
<input type="checkbox"/> Malfunction					Complete Section 2 Below	
<input type="checkbox"/> Non-malfunction						

Date Form Filled Out: _____ Signature: _____

* Standard Operating Procedure (SCP) for Flare Startups (Manual & Automatic) and Shutdowns are provided in SSM Plan

**If SCP in SSM Plan was not followed, notify Market Area General Manager, District Manager or Engineering/Compliance Manager.

Section 2 - Malfunction Events Only

Step	Corrective Action Procedures for All Malfunctions	Check one of the following for each step:	
		Procedure completed	Procedure Not Applicable
1.	Determine if the malfunction causing an unsafe operating condition (air entering landfill or piping, smoking, vibration, or other problem), which may harm people, the environment or the landfill gas control equipment. <i>If conditions are unsafe, notify your supervisor and follow steps under No. 3</i>		
2.	Determine if landfill gas being released to the air (can you smell landfill gas, or measure/detect uncombusted gas flow?). <i>If landfill gas is being released, follow steps under No. 3</i>		
3.	If unsafe operating condition exists, or landfill gas is being released to the air, stop (if possible) landfill gas flow by one or more of the following: a. Close nearest valve to source of emissions b. Place a temporary cap on piping c. Apply other device (i.e. duct tape) d. Shut down blower e. Turn off main power disconnect switch to blower f. Other (Describe): _____ Note: If flare is shut down, follow shutdown SCP and record shutdown time in Section 1 (above)		
4.	Determine if other personnel/resource (qualified technician, electrician, consultant or other) are needed for malfunction diagnosis. <i>If other personnel or resources are not needed, go to No. 6</i>		
5.	Contact qualified resource: a. Record contact name, date and time: _____ b. Contact site representative with information recorded in #5.a		
6.	Start malfunction diagnosis.		
7.	Determine if other resources are needed to fix the malfunction (qualified technician, electrician, contractor, on-site resources, manufacturer's representative, or other). <i>If other resources are not needed, go to No. 9</i>		
8.	Contact qualified resource: a. Record contact name, date and time: _____ b. Contact site representative with information recorded in #8.a		
9.	Fix the malfunction.		
10.	Once the malfunction is fixed, re-start the system per SCP if it had been shut down, and record start-up times and dates on this form.		
11.	Record date that malfunction occurred, date that malfunction was repaired, and total time that system was out of service in boxes in Section 1 of this form.		
12.	Sign this form, copy it, and place it in the Start-up, Shutdown, Malfunction file.		
13.	If the procedures listed above were not followed, contact the site engineer immediately.		

Berman Road Landfill - SSM PLAN DEPARTURE REPORT FORM

EVENT CODES

For Start-ups and Shutdowns:

Startup: The setting in operation of an affected source or portion of an affected source for any purpose.

<u>Code</u>	<u>Event</u>
1	Maintenance
2	Suspected Collection System Malfunction
3	Suspected Control Device Malfunction
4	Suspected Continuous Monitoring System Malfunction (Temperature/Flow/Other)
5	Training
6	Gas System Construction/Expansion
99	Other (Describe)

Shutdown: The cessation of operation of an affected source or portion of any source for any purpose.

For Malfunctions:

Malfunction: Any sudden, infrequent and not reasonably preventable failure of air pollution control equipment, process equipment, or a process to operate in a normal or usual manner. Failures that are caused in part by poor maintenance or careless operation are not malfunctions.

10	Automatic shutdown of control device by designed protective systems
11	Autodialer Callout
12	Shutdown alarms that result in the device not shutting down
13	Unalarmed shutdown
14	Control Device Smoking
15	Inspection identified malfunction
16	Loss of power - utility down
17	Loss of power - unknown
18	Damaged Well, Header or Lateral Piping
19	Leaks at wellheads, valves, flanges, test ports, seals, couplings, etc.
20	Condensate Knock-out Problems
21	Collection Piping Blockages
22	Problems due to Settlement
23	Loss of phase
24	Blower overload condition
25	Blower bearing failure
26	Broken belts (if belt-drive) or broken coupling (if direct-drive) in blower
27	Continuous Monitoring System Malfunction - Thermocouple
28	Continuous Monitoring System Malfunction - UV Scanner
29	Continuous Monitoring System Malfunction - Flow Monitor
30	Continuous Monitoring System Malfunction - Flow Recorder
31	Continuous Monitoring System Malfunction - Temperature Recorder
32	Act of God (i.e., lightning, wind, etc.)
99	Other (Describe)

OFFICE: P/15borough, PA
 DATE: 2/7/07
 DESIGNED BY: B. Snyder
 DRAWN BY: B. Snyder
 CHECKED BY: K. Pagan
 APPROVED BY: ---
 DRAWING NUMBER: 121525-B1

Mr. O. V. Sh...
 Shaw Environmental, Inc.
 1000...
 1000...

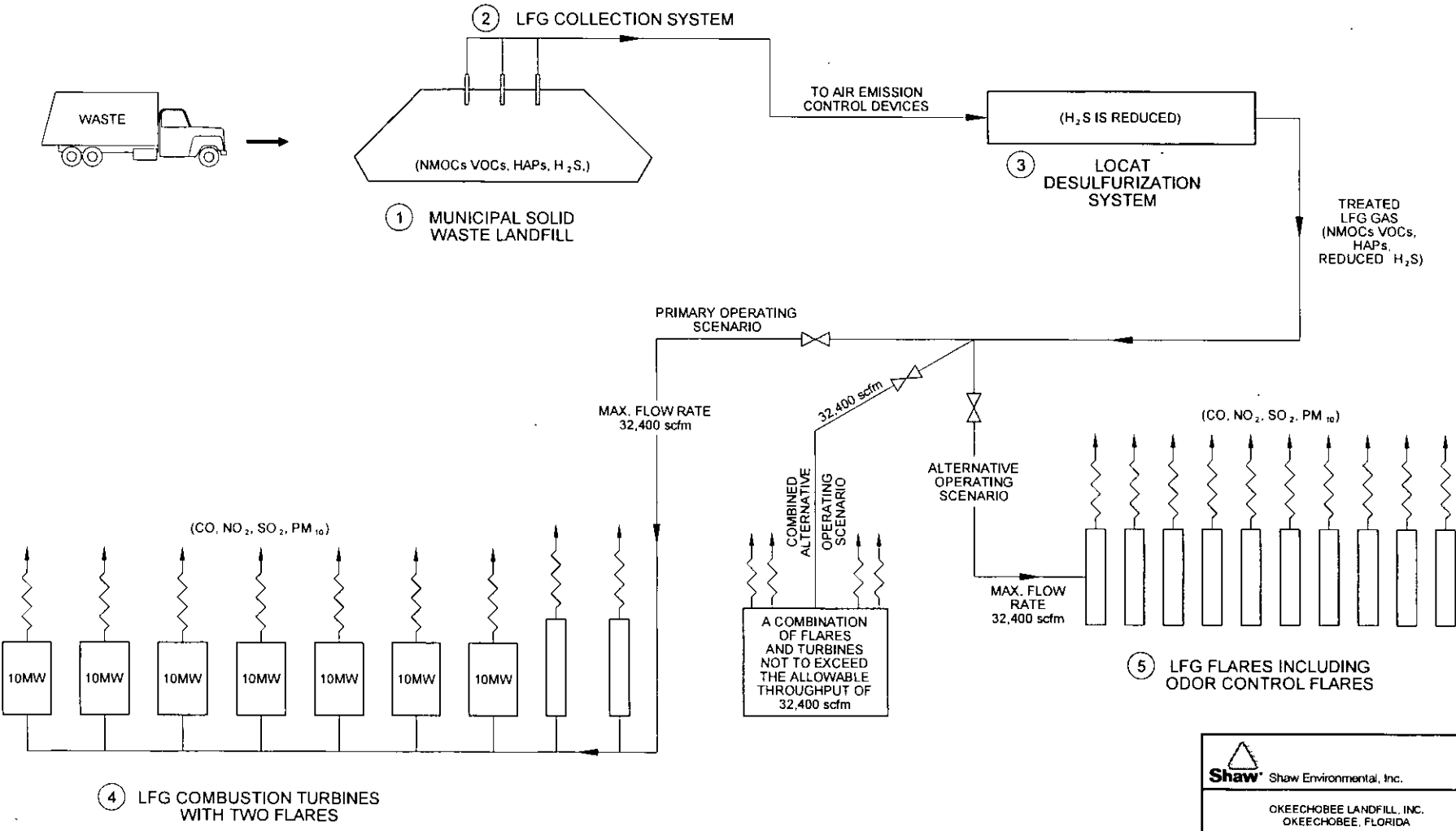

NOTE:
 FOR CLARITY, THIS PROCESS FLOW DIAGRAM DEPICTS THE ADDITIONAL CONTROL DEVICE FOR THE TURBINES OPERATING SCENARIO

Shaw Environmental, Inc.
 OKEECHOBEE LANDFILL, INC.
 OKEECHOBEE, FLORIDA

FIGURE 2
 FACILITY ID 0930104
 PROCESS FLOW DIAGRAM
 AIR CONSTRUCTION
 PERMIT APPLICATION 1270-2