

**DARABI  
AND  
ASSOCIATES, INC.**  
Environmental Consultants

Suite A · 730 North Waldo Road, Gainesville, Florida 32601 · Phone: 904/376-6533

October 22, 1997

Mr. A. A. Linero, P.E., Administrator  
New Source Review Section  
Department of Environmental Protection  
2600 Blair Stone Road  
Tallahassee, Florida 32399

**RECEIVED**

OCT 27 1997

BUREAU OF  
AIR REGULATION

RE: Mulliniks Construction Co., Inc.  
File No. 7775036-002AC, 7775037-002AC, 7775038-002AC

Dear Mr. Linero:

In response to your letter of October 9, 1997, we provide the following additional information:

1. The list of components for each crusher unit is shown on Attachment 1.
2. Process flow diagram for each crusher is attached.
3. Attachment 2 identifies fugitive dust control measures.
4. Attachment 3 shows the fugitive dust emission for each crusher.
5. The unit can be operated in accordance with sub part 000 and rule 62-296.71 FAC where applicable. The 5% standard should be imposed only in areas that are subject to the rule.
6. Attachment 4 provides the required O&M schedule.
7. Copy of the existing air construction permit for Duval County is attached.

Please proceed with the process of this application.

*cc: W. Hanks, BAR  
Districts  
Local Prog.*

Sincerely,

DARABI AND ASSOCIATES, INC.

*Frank A. Darabi*

Frank A. Darabi, P.E.  
President

FAD/lef[MULL.988]  
Enclosure  
xc: Billy Mulliniks

## ATTACHMENT 1

Crusher Plant ID: CP03

Make: Eagle Crusher

Crusher Plant ID: CP04

Make: Cedar Rapids

Crusher Plant ID: CP05

Make: Excel

## ATTACHMENT 2

### **Fugitive Dust Control:**

To control fugitive dust emission from this facility, the best management practice such as the following will be incorporated into the daily operations:

1. All storage material will be kept in a confined area and wetted as needed.
2. The unpaved roads will be sprayed with water on an as needed basis.
3. Care will be exercised while transporting materials to minimize overfilling and spillage.

## ATTACHMENT 3

### Mobile Rock Crusher

#### Fugitive Emission Factors:

**From: Storage Piles at 35,000 tons stored AP.42 - Section 11.2.3**

PM 0.0087 lbs/ton

$$35,000 \times 0.0087 = 304.5 \text{ lbs } 0.15 \text{ TPY}$$

**From: Unpaved Road 0.33 lbs/VMT**

$$0.33 \times 0.5 \text{ VMT} = 0.165 \text{ lbs/hr } 0.165 \text{ TPY}$$

$$(0.165)(2000 \text{ hrs/yr}) =$$

$$\text{Total } \quad \mathbf{0.15 + 0.165 = 0.215 \text{ TPY}}$$

## ATTACHMENT 4

### O&E MANUAL

**Primary Crusher** - visually check bearings, wear items, safety guards, grease all on daily basis.

**Secondary Crusher** - visually check bearings, wear items, safety guards, grease all on daily basis.

**Screens** - check to make sure screens are secured daily, check for damage to screens, grease and safety check daily.

**Conveyor Belts** - check daily for bearings, safety, tears in belts.

**Water Nozzle** - check hourly, and daily to make sure they stay properly positioned for the best control on all controlled places.

**Water Pump** - Make sure pump is checked and properly operating on a daily basis.

**Power Units** - Check engine oil and water daily, make sure all guards are in place.

**Loader** - Check daily general maintenance, oil, water, wear, tires.

PLANT ID: CP03

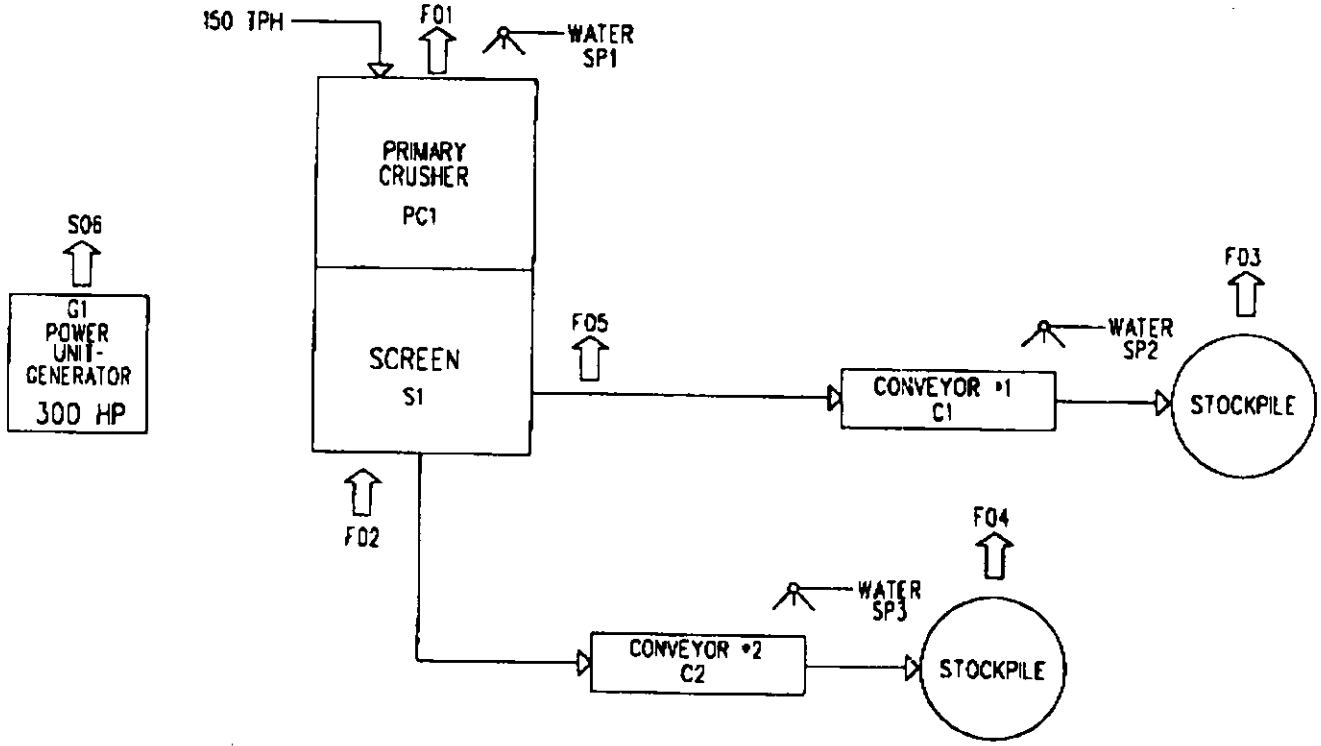

PLANT D: CP04

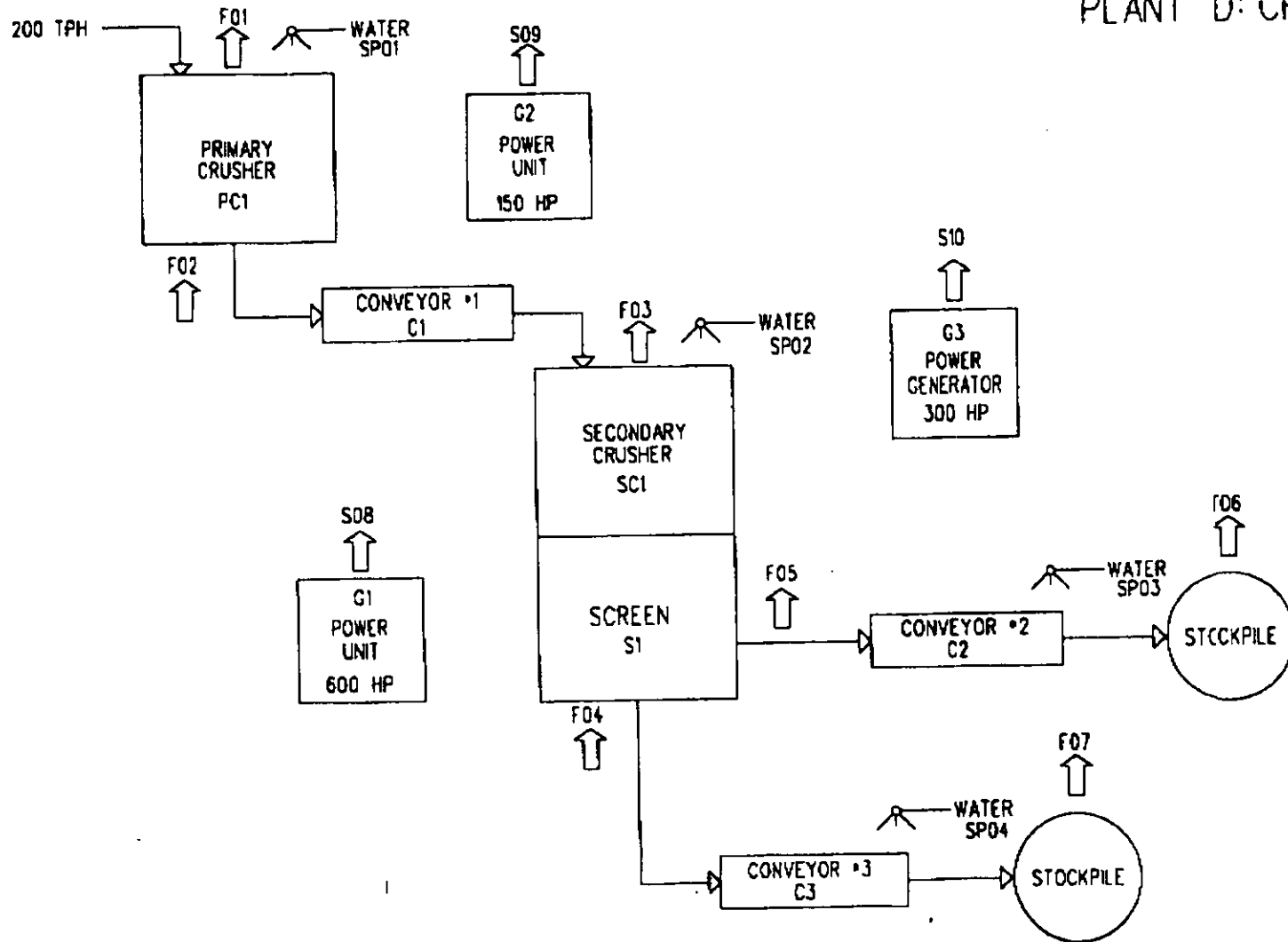

PLANT ID: CP05

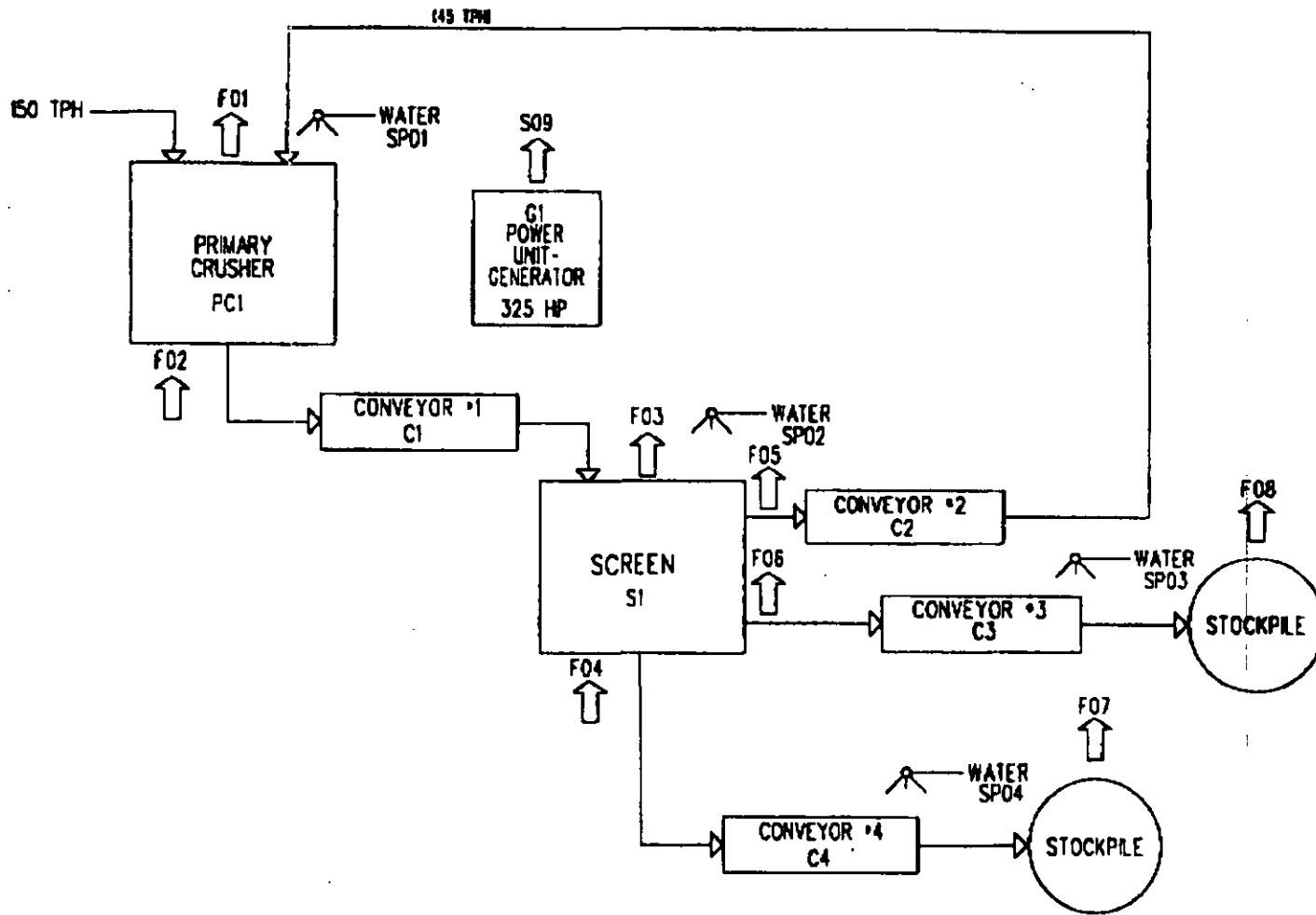





# Department of Environmental Protection

Lawton Chiles  
Governor

Twin Towers Office Building  
2600 Blair Stone Road  
Tallahassee, Florida 32399-2400

Virginia B. Wetherell  
Secretary

October 9, 1997

## CERTIFIED MAIL - RETURN RECEIPT REQUESTED

Mr. Billy Mulliniks, Jr., President  
Mulliniks Construction Company, Inc.  
5937 Soutel Drive  
Jacksonville, Florida 32219

Re: File Nos. 7775036-002-AC, 7775037-002-AC, & 7775038-002-AC  
Mobile Concrete and Asphalt Material Crushing Units

Dear Mr. Mulliniks:

The Department has reviewed your application for permits to construct three mobile concrete and asphalt material crushing units that was received in this office on October 7, 1997. We need the additional information/clarification listed below to process this request.

1. List the key components of the facility. Give make and model number of the equipment when available.
2. Provide a process flow diagram and brochure, if available, on the crusher system.
3. Describe how fugitive dust from this operation will be controlled.
4. Estimate the fugitive particulate matter emissions from each crusher. Use of AP-42 emissions factors to calculate these emissions will be acceptable.
5. Can this unit be operated in compliance with the visible emissions standards of 10 percent opacity for conveyors and 15 percent opacity for crushers specified in the new source performance standard (40 CFR 60, Subpart OOO) and a visible emission standard of 5 percent opacity as required by the particulate matter Reasonably Available Control Technology regulations (Rule 62-296.711, F.A.C.)?
6. Please provide an Operation and Maintenance plan for the crusher unit, including the water spray system used to control fugitive emissions.
7. Please provide a copy of the existing air construction permits for these facilities.

Mr. Billy Mulliniks  
Page 2  
October 9, 1997

The Department will resume processing this application after receipt of the requested information. If you have any questions on this matter, please call Willard Hanks at 850/488-1344.

Sincerely,

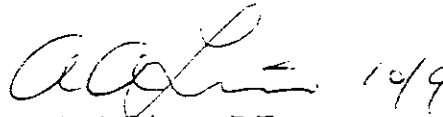

A. A. Linero, P.E.  
Administrator  
New Source Review Section

AAL/wh

cc: Mr. Frank Darabi, Darabi and Assoc.  
District Air Program Administrators  
County Air Program Administrators

Fold at line over top of envelope to

Is your RETURN ADDRESS completed on the reverse side?

**SENDER:**

- Complete items 1 and/or 2 for additional services.
- Complete items 3, 4a, and 4b.
- Print your name and address on the reverse of this form so that we can return this card to you.
- Attach this form to the front of the mailpiece, or on the back if space does not permit.
- Write "Return Receipt Requested" on the mailpiece below the article number.
- The Return Receipt will show to whom the article was delivered and the date delivered.

I also wish to receive the following services (for an extra fee):

1.  Addressee's Address
2.  Restricted Delivery

Consult postmaster for fee.

3. Article Addressed to:  
**Billy Mulliniks, Pres.**  
**Mulliniks Const. Co.**  
**5937 Soutel Dr**  
**Jacksonville, FL**  
32219

4a. Article Number  
**P 265 659 466**

4b. Service Type

<input type="checkbox"/> Registered	<input checked="" type="checkbox"/> Certified
<input type="checkbox"/> Express Mail	<input type="checkbox"/> Insured
<input type="checkbox"/> Return Receipt for Merchandise	<input type="checkbox"/> COD

7. Date of Delivery  
**10-14-97** *A. P. P. [Signature]*

5. Received By: (Print Name)  
*Billy Mulliniks Jr.*

8. Addressee's Address (Only if requested and fee is paid)

6. Signature: (Addressee or Agent)  
*[Signature]*

PS Form **3811**, December 1994 Domestic Return Receipt

Thank you for using Return Receipt Service.

P 265 659 466

US Postal Service  
**Receipt for Certified Mail**

No Insurance Coverage Provided.  
 Do not use for International Mail (See reverse)

Sent to	
<b>Billy Mulliniks</b>	
Street & Number	
<b>Mulliniks Const.</b>	
Post Office, State, & ZIP Code	
<b>Jax, FL</b>	
Postage	\$
Certified Fee	
Special Delivery Fee	
Restricted Delivery Fee	
Return Receipt Showing to Whom & Date Delivered	
Return Receipt Showing to Whom, Date, & Addressee's Address	
<b>TOTAL Postage &amp; Fees</b>	<b>\$</b>
Postmark or Date	<b>10-9-97</b>
7775036-002 7775037-002 "AC"	

PS Form 3800, April 1995