

UNITED STATES SUGAR CORPORATION

Post Office Box 1207 • Clewiston, Florida 33440-1207
Telephone 941/983-8121

June 9, 1997

Mr. Al Linero
New Source Review Section
Florida Dept. of Environmental Protection
2600 Blair Stone Road (MS5505)
Tallahassee, Florida 32399-2400

Re: Construction Permit Application - Portable Rock Crusher

Dear Mr. Linero:

Enclosed are four (4) additional signed copies of the above-referenced application to include with the signed, original application form which we mailed to your office on June 2, 1997.

If you should have any questions or if we can be of further assistance, please contact Mr. Peter Briggs, (941)902-2224, or Mr. David Buff, P.E. (Golder Associates), (352)336-5600.

Sincerely,

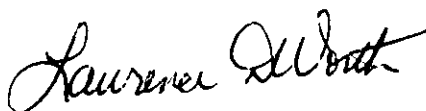

Lawrence D. Worth
Vice-President, Engineering

LDW:js
N:\ROCKPMT2.WPD

Enclosures

cc: Mr. David Buff, P.E.
Golder Associates

cc: W. Hanks, BAR
SFD
Palm Bch Co.

RECEIVED

JUN 11 1997

BUREAU OF
AIR REGULATION

Department of Environmental Protection

DIVISION OF AIR RESOURCES MANAGEMENT

APPLICATION FOR AIR PERMIT - LONG FORM

See Instructions for Form No. 62-210.900(1)

I. APPLICATION INFORMATION

This section of the Application for Air Permit form identifies the facility and provides general information on the scope and purpose of this application. This section also includes information on the owner or authorized representative of the facility (or the responsible official in the case of a Title V source) and the necessary statements for the applicant and professional engineer, where required, to sign and date for formal submittal of the Application for Air Permit to the Department. If the application form is submitted to the Department using ELSA, this section of the Application for Air Permit must also be submitted in hard-copy.

Identification of Facility Addressed in This Application

Enter the name of the corporation, business, governmental entity, or individual that has ownership or control of the facility; the facility site name, if any; and the facility's physical location. If known, also enter the facility identification number.

1. Facility Owner/Company Name: United States Sugar Corporation	
2. Site Name: Agricultural Property	
3. Facility Identification Number: <input checked="" type="checkbox"/>] Unknown	
4. Facility Location Information: Street Address or Other Locator: 111 Ponce De Leon Avenue City: Clewiston County: Henry Zip Code: 33440	
5. Relocatable Facility? <input checked="" type="checkbox"/>] Yes [] No	6. Existing Permitted Facility? [] Yes <input checked="" type="checkbox"/>] No

Application Processing Information (DEP Use)

1. Date of Receipt of Application:	June 5th, 1997
2. Permit Number:	7775035-001-AC
3. PSD Number (if applicable):	
4. Siting Number (if applicable):	

Owner/Authorized Representative or Responsible Official

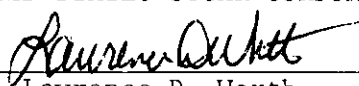
1. Name and Title of Owner/Authorized Representative or Responsible Official: Lawrence Worth, V.P. of Engineering
2. Owner/Authorized Representative or Responsible Official Mailing Address: Organization/Firm: United States Sugar Corporation Street Address: 111 Ponce De Leon Ave. City: Clewiston State: FL Zip Code: 33440
3. Owner/Authorized Representative or Responsible Official Telephone Numbers: Telephone: (941) 983-8121 Fax: (941) 983-0223
4. Owner/Authorized Representative or Responsible Official Statement: <i>I, the undersigned, am the owner or authorized representative* of the non-Title V source addressed in this Application for Air Permit or the responsible official, as defined in Rule 62-210.200, F.A.C., of the Title V source addressed in this application, whichever is applicable. I hereby certify, based on information and belief formed after reasonable inquiry, that the statements made in this application are true, accurate and complete and that, to the best of my knowledge, any estimates of emissions reported in this application are based upon reasonable techniques for calculating emissions. The air pollutant emissions units and air pollution control equipment described in this application will be operated and maintained so as to comply with all applicable standards for control of air pollutant emissions found in the statutes of the State of Florida and rules of the Department of Environmental Protection and revisions thereof. I understand that a permit, if granted by the Department, cannot be transferred without authorization from the Department, and I will promptly notify the Department upon sale or legal transfer of any permitted emissions unit.</i> UNITED STATES SUGAR CORPORATION By: <u></u> <u>6/3/97</u> Signature Lawrence D. Worth Date Vice-President, Engineering

* Attach letter of authorization if not currently on file.

Scope of Application

This Application for Air Permit addresses the following emissions unit(s) at the facility. An Emissions Unit Information Section (a Section III of the form) must be included for each emissions unit listed.

Emissions Unit ID	Description of Emissions Unit	Permit Type
Unit # Unit ID		
1R	Portable Rock Crusher	ACLD
<p>See individual Emissions Unit (EU) sections for more detailed descriptions. Multiple EU IDs indicated with an asterisk (*). Regulated EU indicated with an "R".</p>		

Purpose of Application and Category

Check one (except as otherwise indicated):

Category I: All Air Operation Permit Applications Subject to Processing Under Chapter 62-213, F.A.C.

This Application for Air Permit is submitted to obtain:

-] Initial air operation permit under Chapter 62-213, F.A.C., for an existing facility which is classified as a Title V source.

-] Initial air operation permit under Chapter 62-213, F.A.C., for a facility which, upon start up of one or more newly constructed or modified emissions units addressed in this application, would become classified as a Title V source.

Current construction permit number: _____

-] Air operation permit renewal under Chapter 62-213, F.A.C., for a Title V source.

Operation permit to be renewed: _____

-] Air operation permit revision for a Title V source to address one or more newly constructed or modified emissions units addressed in this application.

Current construction permit number: _____

Operation permit to be renewed: _____

-] Air operation permit revision or administrative correction for a Title V source to address one or more proposed new or modified emissions units and to be processed concurrently with the air construction permit application. Also check Category III.

Operation permit to be revised/corrected: _____

-] Air operation permit revision for a Title V source for reasons other than construction or modification of an emissions unit. Give reason for the revision e.g., to comply with a new applicable requirement or to request approval of an "Early Reductions" proposal.

Operation permit to be revised: _____

Reason for revision: _____

Category II: All Air Construction Permit Applications Subject to Processing Under Rule 62-210.300(2)(b), F.A.C.

This Application for Air Permit is submitted to obtain:

- Initial air operation permit under Rule 62-210.300(2)(b), F.A.C., for an existing facility seeking classification as a synthetic non-Title V source.

Current operation/construction permit number(s): _____

- Renewal air operation permit under Rule 62-210.300(2)(b), F.A.C., for a synthetic non-Title V source.

Operation permit to be renewed: _____

- Air operation permit revision for a synthetic non-Title V source. Give reason for revision; e.g.; to address one or more newly constructed or modified emissions units.

Operation permit to be revised: _____

Reason for revision: _____

Category III: All Air Construction Permit Applications for All Facilities and Emissions Units.

This Application for Air Permit is submitted to obtain:

- Air construction permit to construct or modify one or more emissions units within a facility (including any facility classified as a Title V source).

Current operation permit number(s), if any: _____

- Air construction permit to make federally enforceable an assumed restriction on the potential emissions of one or more existing, permitted emissions units.

Current operation permit number(s): _____

- Air construction permit for one or more existing, but unpermitted, emissions units.

Application Processing Fee

Check one:

Attached - Amount: \$ \$ 2,000.00

Not Applicable.

Construction/Modification Information

1. Description of Proposed Project or Alterations: Application for a portable rock crusher. The rock crusher is used principally on USSC (or its subsidiaries) controlled property to crush rocks, boulders, etc.
2. Projected or Actual Date of Commencement of Construction : 1 Jun 1997
3. Projected Date of Completion of Construction : 1 Jun 1997

Professional Engineer Certification

1. Professional Engineer Name: David A. Buff Registration Number: 19011
2. Professional Engineer Mailing Address: Organization/Firm: Golder Associates Street Address: 6241 NW 23rd Street, Suite 500 City: Gainesville State: FL Zip Code: 32653-1500
3. Professional Engineer Telephone Numbers: Telephone: (352) 336-5600 Fax: (352) 336-6603

4. Professional Engineer's Statement:

I, the undersigned, hereby certify, except as particularly noted herein, that:*

(1) To the best of my knowledge, there is reasonable assurance that the air pollutant emissions unit(s) and the air pollution control equipment described in this Application for Air Permit, when properly operated and maintained, will comply with all applicable standards for control of air pollutant emissions found in the Florida Statutes and rules of the Department of Environmental Protection; and

(2) To the best of my knowledge, any emission estimates reported or relied on in this application are true, accurate, and complete and are either based upon reasonable techniques available for calculating emissions or, for emission estimates of hazardous air pollutants not regulated for an emissions unit addressed in this application, based solely upon the materials, information and calculations submitted with this application.

If the purpose of this application is to obtain a Title V source air operation permit (check here [] if so), I further certify that each emissions unit described in this Application for Air Permit, when properly operated and maintained, will comply with the applicable requirements identified in this application to which the unit is subject, except those emissions units for which a compliance schedule is submitted with this application.

If the purpose of this application is to obtain an air construction permit for one or more proposed new or modified emissions units (check here [X] if so), I further certify that the engineering features of each such emissions unit described in this application have been designed or examined by me or individuals under my direct supervision and found to be in conformity with sound engineering principles applicable to the control of emissions of the air pollutants characterized in this application.

If the purpose of this application is to obtain an initial air operation permit or operation permit revision for one or more newly constructed or modified emissions units (check here [] if so), I further certify that, with the exception of any changes detailed as part of this application, each such emissions unit has been constructed or modified in substantial accordance with the information given in the corresponding application for air construction permit and with all provisions contained in such permit.

David A. Buff _____ 5/20/97
Signature Date
(seal)

* Attach any exception to certification statement.

Application Contact

1. Name and Title of Application Contact: Lawrence Worth, V.P. of Engineering
2. Application Contact Mailing Address: Organization/Firm: United States Sugar Corporation Street Address: 111 Ponce De Leon Av;PO Dr1207 City: Clewiston State: FL Zip Code: 33440
3. Application Contact Telephone Numbers: Telephone: (941) 983-8121 Fax: (941) 983-0223

Application Comment

II. FACILITY INFORMATION

A. GENERAL FACILITY INFORMATION

Facility Location and Type

1. Facility UTM Coordinates: Zone: _____ East (km): _____ North (km): _____			
2. Facility Latitude/Longitude: Latitude (DD/MM/SS): / / Longitude: (DD/MM/SS): / /			
3. Governmental Facility Code: 0	4. Facility Status Code: A	5. Facility Major Group SIC Code: 14	6. Facility SIC(s): 1422, 1427
7. Facility Comment (limit to 500 characters): Portable rock crusher will operate principally on property controlled (owned or leased) by U.S. Sugar Corporation or its subsidiaries. These areas are located primarily in Palm Beach, Glades and Hendry counties. See Attachment A for further information.			

Facility Contact

1. Name and Title of Facility Contact: Lawrence Worth, V.P. of Engineering
2. Facility Contact Mailing Address: Organization/Firm: United States Sugar Corporation Street Address: 111 Ponce De Leon Av; PO Dr 1207 City: Clewiston State: FL Zip Code: 33440
3. Facility Contact Telephone Numbers: Telephone: (941) 983-8121 Fax: (941) 983-4255

Facility Regulatory Classifications

1. Small Business Stationary Source? <input type="checkbox"/> Yes <input checked="" type="checkbox"/> No <input type="checkbox"/> Unknown
2. Title V Source? <input type="checkbox"/> Yes <input checked="" type="checkbox"/> No
3. Synthetic Non-Title V Source? <input type="checkbox"/> Yes, <input checked="" type="checkbox"/> No
4. Major Source of Pollutants Other than Hazardous Air Pollutants (HAPs)? <input type="checkbox"/> Yes <input checked="" type="checkbox"/> No
5. Synthetic Minor Source of Pollutants Other than HAPs? <input type="checkbox"/> Yes <input checked="" type="checkbox"/> No
6. Major Source of Hazardous Air Pollutants (HAPs)? <input type="checkbox"/> Yes <input checked="" type="checkbox"/> No
7. Synthetic Minor Source of HAPs? <input type="checkbox"/> Yes <input checked="" type="checkbox"/> No
8. One or More Emissions Units Subject to NSPS? <input type="checkbox"/> Yes <input checked="" type="checkbox"/> No
9. One or More Emissions Units Subject to NESHAP? <input type="checkbox"/> Yes <input checked="" type="checkbox"/> No
10. Title V Source by EPA Designation? <input type="checkbox"/> Yes <input checked="" type="checkbox"/> No
11. Facility Regulatory Classifications Comment (limit to 200 characters):

B. FACILITY REGULATIONS

Rule Applicability Analysis (Required for Category II applications and Category III applications involving non Title-V sources. See Instructions.)

62-210.700(1) Excess Emissions
62-210.700(4) Excess Emissions
62-210.700(5) Excess Emissions
62-210.700(6) Excess Emissions
62-212.300 General Preconstruction Review Requirements
62-296.320(2) Objectionable Odor Prohibited
62-296.320(4)(a)2. Particulate Matter Emissions Standard
62-296.320(4)(b) General Visible Emissions Standard
62-296.320(4)(c) Unconfined Emissions of Particulate Matter
62-297.310(2)(b) Operating Rate During Testing
62-297.310(4)(a)2. Opacity Compliance Tests
62-297.310(5) Determination of Process Variables
62-297.310(7) Frequency of Compliance Tests
62-297.310(8) Test Reports
62-297.401(9)(a) EPA Method 9

List of Applicable Regulations (Required for Category I applications and Category III applications involving Title-V sources. See Instructions.)

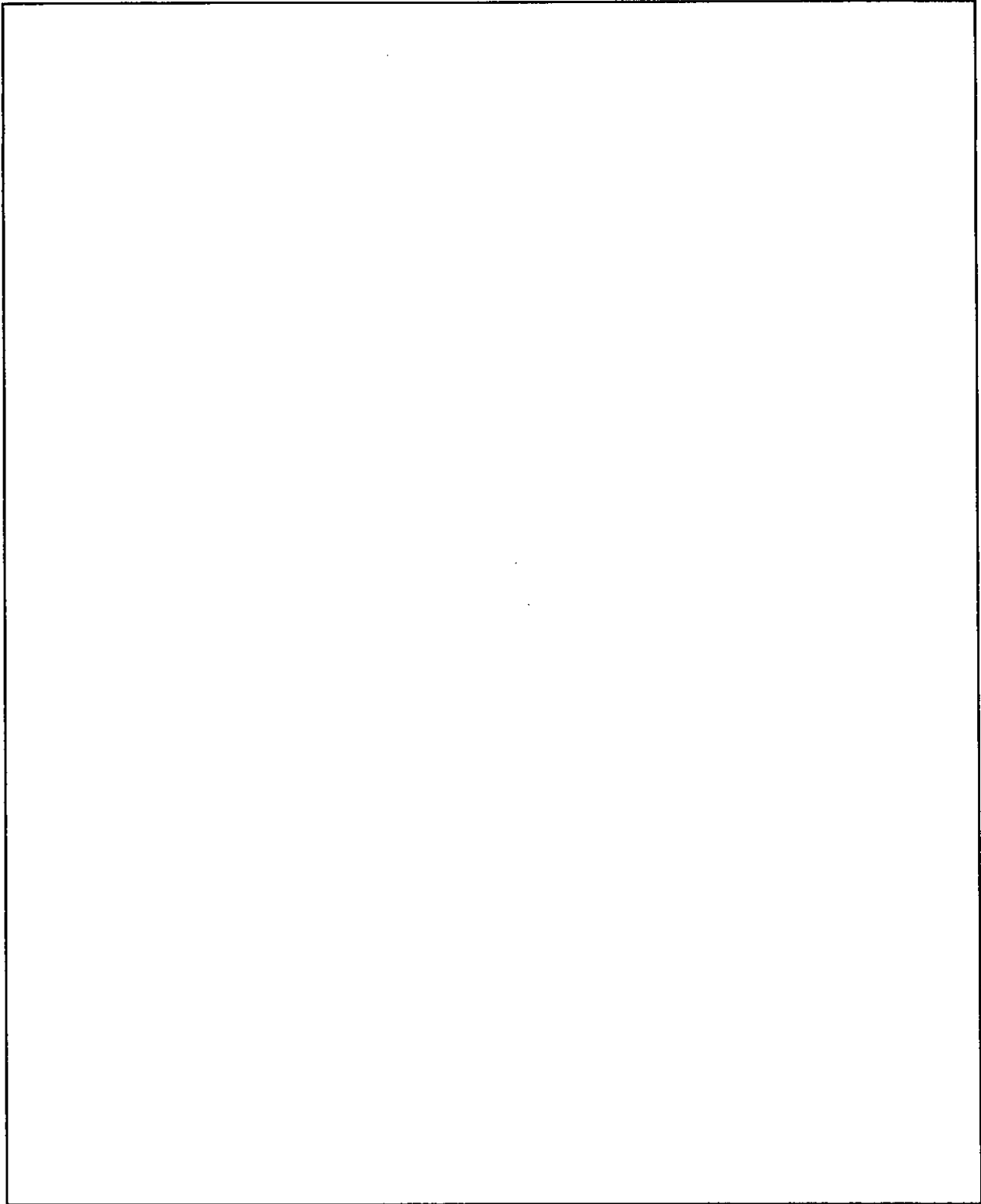

C. FACILITY POLLUTANTS

Facility Pollutant Information

1. Pollutant Emitted	2. Pollutant Classification
PM Particulate Matter - Total	B
PM10 Particulate Matter - PM10	B

D. FACILITY POLLUTANT DETAIL INFORMATION

Facility Pollutant Detail Information:

1. Pollutant Emitted:		
2. Requested Emissions Cap:	(lb/hr)	(tons/yr)
3. Basis for Emissions Cap Code:		
4. Facility Pollutant Comment (limit to 400 characters):		

Facility Pollutant Detail Information:

1. Pollutant Emitted:		
2. Requested Emissions Cap:	(lb/hr)	(tons/yr)
3. Basis for Emissions Cap Code:		
4. Facility Pollutant Comment (limit to 400 characters):		

E. FACILITY SUPPLEMENTAL INFORMATION

Supplemental Requirements for All Applications

1. Area Map Showing Facility Location: <input checked="" type="checkbox"/> Attached, Document ID: <u>Attachment A</u> <input type="checkbox"/> Not Applicable <input type="checkbox"/> Waiver Requested
2. Facility Plot Plan: <input checked="" type="checkbox"/> Attached, Document ID: <u>Attachment B</u> <input type="checkbox"/> Not Applicable <input type="checkbox"/> Waiver Requested
3. Process Flow Diagram(s): <input checked="" type="checkbox"/> Attached, Document ID(s): <u>Attachment A</u> <input type="checkbox"/> Not Applicable <input type="checkbox"/> Waiver Requested
4. Precautions to Prevent Emissions of Unconfined Particulate Matter: <input checked="" type="checkbox"/> Attached, Document ID: <u>Attachment A</u> <input type="checkbox"/> Not Applicable <input type="checkbox"/> Waiver Requested
5. Fugitive Emissions Identification: <input checked="" type="checkbox"/> Attached, Document ID: <u>Attachment A</u> <input type="checkbox"/> Not Applicable <input type="checkbox"/> Waiver Requested
6. Supplemental Information for Construction Permit Application: <input checked="" type="checkbox"/> Attached, Document ID: <u>Attachment A</u> <input type="checkbox"/> Not Applicable

Additional Supplemental Requirements for Category I Applications Only

7. List of Proposed Exempt Activities: <input type="checkbox"/> Attached, Document ID: _____ <input type="checkbox"/> Not Applicable
8. List of Equipment/Activities Regulated under Title VI: <input type="checkbox"/> Attached, Document ID: _____ <input type="checkbox"/> Equipment/Activities On site but Not Required to be Individually Listed <input type="checkbox"/> Not Applicable
9. Alternative Methods of Operation: <input type="checkbox"/> Attached, Document ID: _____ <input type="checkbox"/> Not Applicable
10. Alternative Modes of Operation (Emissions Trading): <input type="checkbox"/> Attached, Document ID: _____ <input type="checkbox"/> Not Applicable

<p>11. Identification of Additional Applicable Requirements:</p> <p><input type="checkbox"/> Attached, Document ID: _____</p> <p><input type="checkbox"/> Not Applicable</p>
<p>12. Compliance Assurance Monitoring Plan:</p> <p><input type="checkbox"/> Attached, Document ID: _____</p> <p><input type="checkbox"/> Not Applicable</p>
<p>13. Risk Management Plan Verification:</p> <p><input type="checkbox"/> Plan Submitted to Implementing Agency - Verification Attached Document ID: _____</p> <p><input type="checkbox"/> Plan to be Submitted to Implementing Agency by Required Date</p> <p><input type="checkbox"/> Not Applicable</p>
<p>14. Compliance Report and Plan</p> <p><input type="checkbox"/> Attached, Document ID: _____</p> <p><input type="checkbox"/> Not Applicable</p>
<p>15. Compliance Statement (Hard-copy Required)</p> <p><input type="checkbox"/> Attached, Document ID: _____</p> <p><input type="checkbox"/> Not Applicable</p>

III. EMISSIONS UNIT INFORMATION

A separate Emissions Unit Information Section (including subsections A through L as required) must be completed for each emissions unit addressed in this Application for Air Permit. If submitting the application form in hard copy, indicate, in the space provided at the top of each page, the number of this Emissions Unit Information Section and the total number of Emissions Unit Information Sections submitted as part of this application. Some of the subsections comprising the Emissions Unit Information Section of the form are intended for regulated emissions units only. Others are intended for both regulated and unregulated emissions units. Each subsection is appropriately marked.

**A. TYPE OF EMISSIONS UNIT
(Regulated and Unregulated Emissions Units)****Type of Emissions Unit Addressed in This Section**

1. Regulated or Unregulated Emissions Unit? Check one:

The emissions unit addressed in this Emissions Unit Information Section is a regulated emissions unit.

The emissions unit addressed in this Emissions Unit Information Section is an unregulated emissions unit.

2. Single Process, Group of Processes, or Fugitive Only? Check one:

This Emissions Unit information Section addresses, as a single emissions unit, a single process or production unit, or activity, which produces one or more air pollutants and which has at least one definable emission point (stack or vent).

This Emissions Unit Information Section addresses, as a single emissions unit, a group of process or production units and activities which has at least one definable emission point (stack or vent) but may also produce fugitive emissions.

This Emissions Unit Information Section addresses, as a single emissions unit, one or more process or production units and activities which produce fugitive emissions only.

**B. GENERAL EMISSIONS UNIT INFORMATION
(Regulated and Unregulated Emissions Units)**

Emissions Unit Description and Status

<p>1. Description of Emissions Unit Addressed in This Section (limit to 60 characters): Portable Rock Crusher</p>		
<p>2. Emissions Unit Identification Number: <input checked="" type="checkbox"/> No Corresponding ID <input type="checkbox"/> Unknown</p>		
<p>3. Emissions Unit Status Code: A</p>	<p>4. Acid Rain Unit? <input type="checkbox"/> Yes <input checked="" type="checkbox"/> No</p>	<p>5. Emissions Unit Major Group SIC Code: 14</p>
<p>6. Emissions Unit Comment (limit to 500 characters): This emissions unit represents a portable rock crusher. This is a relocatable emissions unit.</p>		

Emissions Unit Control Equipment Information

A.

1. Description (limit to 200 characters):
2. Control Device or Method Code:

B.

1. Description (limit to 200 characters):
2. Control Device or Method Code:

C.

1. Description (limit to 200 characters):
2. Control Device or Method Code:

**C. EMISSIONS UNIT DETAIL INFORMATION
(Regulated Emissions Units Only)**

Emissions Unit Details

1. Initial Startup Date:		
2. Long-term Reserve Shutdown Date:		
3. Package Unit:		
Manufacturer: Iowa Manufacturing Company	Model Number: 3633	
4. Generator Nameplate Rating:		MW
5. Incinerator Information:		
Dwell Temperature:		°F
Dwell Time:		seconds
Incinerator Afterburner Temperature:		°F

Emissions Unit Operating Capacity

1. Maximum Heat Input Rate:	1	mmBtu/hr
2. Maximum Incineration Rate:	lbs/hr	tons/day
3. Maximum Process or Throughput Rate:	325	tons rock/hour
4. Maximum Production Rate:		
5. Operating Capacity Comment (limit to 200 characters):		
Rock Crusher has a 318 H.P. diesel engine		

Emissions Unit Operating Schedule

1. Requested Maximum Operating Schedule:		
20	hours/day	7
		days/week
52	weeks/yr	7,280
		hours/yr

**D. EMISSIONS UNIT REGULATIONS
(Regulated Emissions Units Only)**

Rule Applicability Analysis (Required for Category II Applications and Category III applications involving non-Title-V sources. See Instructions.)

62-210.700(1) Excess Emissions
62-210.700(4) Excess Emissions
62-210.700(5) Excess Emissions
62-210.700(6) Excess Emissions
62-212.300 General Preconstruction Review Requirements
62-296.320(2) Objectionable Odor Prohibited
62-296.320(4)(a)2. Particulate Matter Emissions Standard
62-296.320(4)(b) General Visible Emissions Standard
62-296.320(4)(c) Unconfined Emissions of Particulate Matter
62-297.310(2)(b) Operating Rate During Testing
62-297.310(4)(a)2. Opacity Compliance Tests
62-297.310(5) Determination of Process Variables
62-297.310(7) Frequency of Compliance Tests
62-297.310(8) Test Reports
62-297.401(9)(a) EPA Method 9

List of Applicable Regulations (Required for Category I applications and Category III applications involving Title-V sources. See Instructions.)

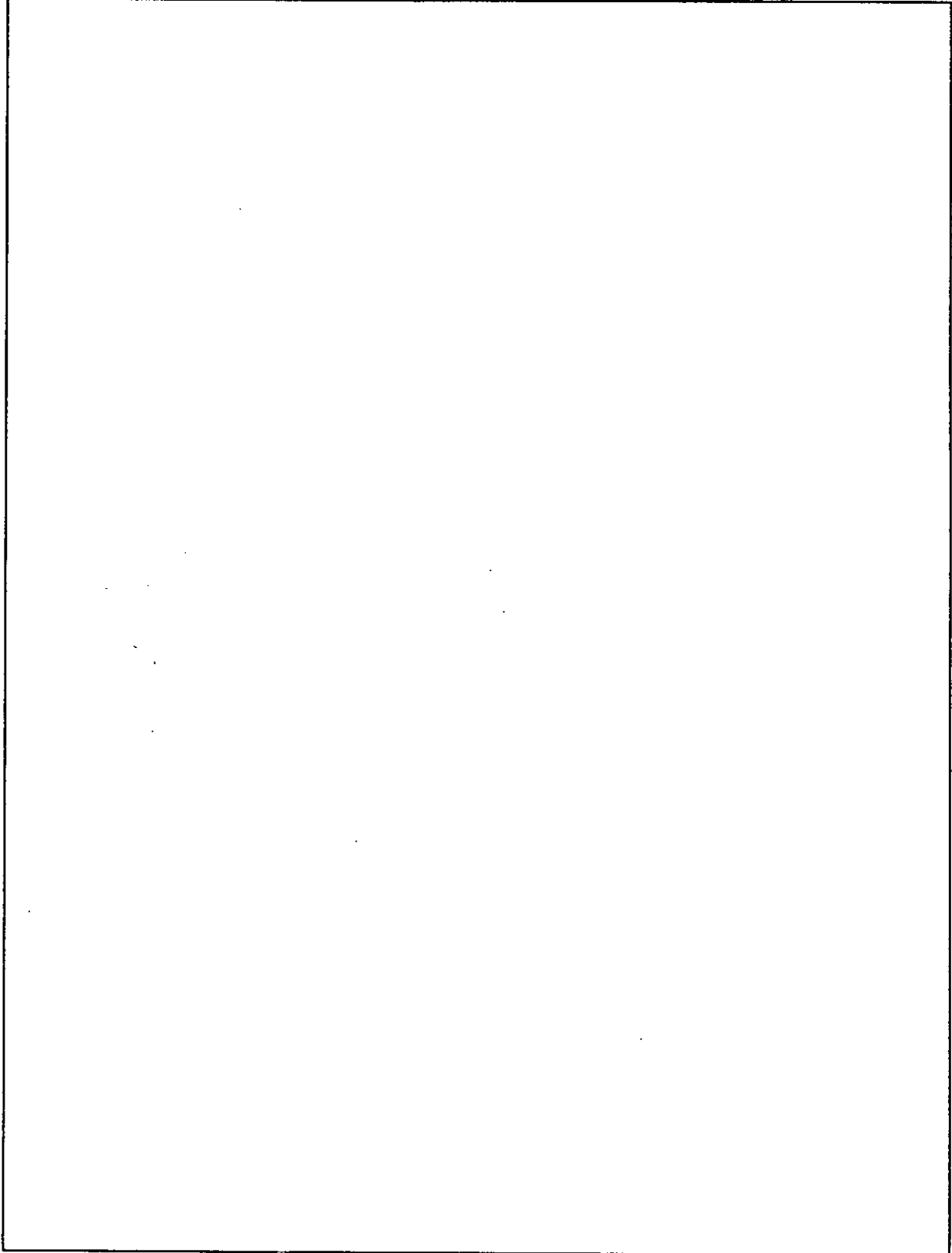

**E. EMISSION POINT (STACK/VENT) INFORMATION
(Regulated Emissions Units Only)**

Emission Point Description and Type

1. Identification of Point on Plot Plan or Flow Diagram: RC1	
2. Emission Point Type Code: []1 []2 []3 [x]4	
3. Descriptions of Emissions Points Comprising this Emissions Unit for VE Tracking (limit to 100 characters per point): 1. Exhaust on diesel engine. 2. Rock Crusher	
4. ID Numbers or Descriptions of Emission Units with this Emission Point in Common:	
5. Discharge Type Code: []D [x]F []H []P []R []V []W	
6. Stack Height:	feet
7. Exit Diameter:	feet
8. Exit Temperature:	77 °F

9. Actual Volumetric Flow Rate:	acfm
10. Percent Water Vapor:	%
11. Maximum Dry Standard Flow Rate:	dscfm
12. Nonstack Emission Point Height:	9 feet
13. Emission Point UTM Coordinates:	
Zone:	East (km): North (km):
14. Emission Point Comment (limit to 200 characters):	
<p>This emissions unit is a portable source. The emission point is identified as Fugitive PM Emissions.</p>	

**F. SEGMENT (PROCESS/FUEL) INFORMATION
(Regulated and Unregulated Emissions Units)**

Segment Description and Rate: Segment 1 of 2

1. Segment Description (Process/Fuel Type and Associated Operating Method/Mode) (limit to 500 characters): Mineral Products - Stone Quarrying-Processing; Primary Crushing	
2. Source Classification Code (SCC): <p style="text-align: center;">3-05-020-01</p>	
3. SCC Units: <p style="text-align: center;">Tons Raw Material</p>	
4. Maximum Hourly Rate: <p style="text-align: center;">325</p>	5. Maximum Annual Rate: <p style="text-align: center;">2,366,000</p>
6. Estimated Annual Activity Factor: 	
7. Maximum Percent Sulfur: 	8. Maximum Percent Ash:
9. Million Btu per SCC Unit: 	
10. Segment Comment (limit to 200 characters): 	

Segment Description and Rate: Segment 2 of 2

1. Segment Description (Process/Fuel Type and Associated Operating Method/Mode) (limit to 500 characters): Internal Combustion Engines - Industrial: Distillate Oil	
2. Source Classification Code (SCC): 2-02-001-02	
3. SCC Units: 1,000 Gallons Burned	
4. Maximum Hourly Rate: 0.01	5. Maximum Annual Rate: 73
6. Estimated Annual Activity Factor:	
7. Maximum Percent Sulfur: 0.5	8. Maximum Percent Ash:
9. Million Btu per SCC Unit: 140	
10. Segment Comment (limit to 200 characters): No. 2 Diesel Fuel	

**G. EMISSIONS UNIT POLLUTANTS
(Regulated and Unregulated Emissions Units)**

1. Pollutant Emitted	2. Primary Control Device Code	3. Secondary Control Device Code	4. Pollutant Regulatory Code
PM			NS
PM10			NS
NOx			NS
CO			NS

H. EMISSIONS UNIT POLLUTANT DETAIL INFORMATION
(Regulated Emissions Units Only - Emissions Limited Pollutants Only)**Pollutant Detail Information:**

1. Pollutant Emitted: PM		
2. Total Percent Efficiency of Control:		%
3. Potential Emissions:	0.93 lb/hour	3.38 tons/year
4. Synthetically Limited? <input checked="" type="checkbox"/> Yes <input type="checkbox"/> No		
5. Range of Estimated Fugitive/Other Emissions: <input type="checkbox"/> 1 <input type="checkbox"/> 2 <input type="checkbox"/> 3 _____ to _____ tons/yr		
6. Emission Factor:		7 E-04 lb/ton
Reference: AP-42		
7. Emissions Method Code: <input type="checkbox"/> 0 <input type="checkbox"/> 1 <input type="checkbox"/> 2 <input checked="" type="checkbox"/> 3 <input type="checkbox"/> 4 <input type="checkbox"/> 5		
8. Calculation of Emissions (limit to 600 characters): Rock Crushing: 325 TPH x 0.0007 lb/ton = 0.23 lb/hr; 0.23 lb/hr x 7,280 hr/yr x 1 ton/2,000 lb = 0.83 TPY; Diesel Combustion: 318 hp x 0.0022 lb/hp-hr = 0.70 lb/hr; 0.70 lb/hr x 7,280 x 1 ton/2,000 = 2.55 TPY		
9. Pollutant Potential/Estimated Emissions Comment (limit to 200 characters):		

Emissions Unit Information Section 1 of 1
Allowable Emissions (Pollutant identified on front page)

A.

1. Basis for Allowable Emissions Code:		
2. Future Effective Date of Allowable Emissions:		
3. Requested Allowable Emissions and Units:		
4. Equivalent Allowable Emissions:	lb/hour	tons/year
5. Method of Compliance (limit to 60 characters):		
6. Pollutant Allowable Emissions Comment (Desc. of Related Operating Method/Mode). (limit to 200 characters):		

B.

1. Basis for Allowable Emissions Code:		
2. Future Effective Date of Allowable Emissions:		
3. Requested Allowable Emissions and Units:		
4. Equivalent Allowable Emissions:	lb/hour	tons/year
5. Method of Compliance (limit to 60 characters):		
6. Pollutant Allowable Emissions Comment (Desc. of Related Operating Method/Mode). (limit to 200 characters):		

H. EMISSIONS UNIT POLLUTANT DETAIL INFORMATION
(Regulated Emissions Units Only - Emissions Limited Pollutants Only)

Pollutant Detail Information:

1. Pollutant Emitted: PM10		
2. Total Percent Efficiency of Control:	%	
3. Potential Emissions:	0.93 lb/hour	3.38 tons/year
4. Synthetically Limited? <input checked="" type="checkbox"/> Yes <input type="checkbox"/> No		
5. Range of Estimated Fugitive/Other Emissions:		
<input type="checkbox"/> 1 <input type="checkbox"/> 2 <input type="checkbox"/> 3 _____ to _____ tons/yr		
6. Emission Factor: 7 E-04 lb/ton		
Reference: AP-42		
7. Emissions Method Code:		
<input type="checkbox"/> 0 <input type="checkbox"/> 1 <input type="checkbox"/> 2 <input checked="" type="checkbox"/> 3 <input type="checkbox"/> 4 <input type="checkbox"/> 5		
8. Calculation of Emissions (limit to 600 characters):		
Rock Crushing: 325 TPH x 0.0007 lb/ton = 0.23 lb/hr; 0.23 lb/hr x 7,280 hr/yr x 1 ton/2,000 lb = 0.83 TPY; Diesel Combustion: 318 hp x 0.0022 lb/hp-hr = 0.70 lb/hr; 0.70 lb/hr x 7,280 x 1 ton/2,000 = 2.55 TPY		
9. Pollutant Potential/Estimated Emissions Comment (limit to 200 characters):		

Emissions Unit Information Section 1 of 1
Allowable Emissions (Pollutant identified on front page)

A.

1. Basis for Allowable Emissions Code:		
2. Future Effective Date of Allowable Emissions:		
3. Requested Allowable Emissions and Units:		
4. Equivalent Allowable Emissions:	lb/hour	tons/year
5. Method of Compliance (limit to 60 characters):		
6. Pollutant Allowable Emissions Comment (Desc. of Related Operating Method/Mode) (limit to 200 characters):		

B.

1. Basis for Allowable Emissions Code:		
2. Future Effective Date of Allowable Emissions:		
3. Requested Allowable Emissions and Units:		
4. Equivalent Allowable Emissions:	lb/hour	tons/year
5. Method of Compliance (limit to 60 characters):		
6. Pollutant Allowable Emissions Comment (Desc. of Related Operating Method/Mode) (limit to 200 characters):		

H. EMISSIONS UNIT POLLUTANT DETAIL INFORMATION
(Regulated Emissions Units Only - Emissions Limited Pollutants Only)

Pollutant Detail Information:

1. Pollutant Emitted: NOx	
2. Total Percent Efficiency of Control:	%
3. Potential Emissions:	9.9 lb/hour 35.9 tons/year
4. Synthetically Limited? <input checked="" type="checkbox"/> Yes <input type="checkbox"/> No	
5. Range of Estimated Fugitive/Other Emissions: <input type="checkbox"/> 1 <input type="checkbox"/> 2 <input type="checkbox"/> 3 _____ to _____ tons/yr	
6. Emission Factor:	0.031 lb/hp-hr
Reference: AP-42	
7. Emissions Method Code: <input type="checkbox"/> 0 <input type="checkbox"/> 1 <input type="checkbox"/> 2 <input checked="" type="checkbox"/> 3 <input type="checkbox"/> 4 <input type="checkbox"/> 5	
8. Calculation of Emissions (limit to 600 characters): 318 hp x 0.031 lb/hp-hr = 9.9 lb/hr; 9.9 lb/hr x 7,280 hr/yr x 1 ton/2,000 lb = 35.9 TPY	
9. Pollutant Potential/Estimated Emissions Comment (limit to 200 characters):	

Emissions Unit Information Section 1 of 1
Allowable Emissions (Pollutant identified on front page)

A.

1. Basis for Allowable Emissions Code:		
2. Future Effective Date of Allowable Emissions:		
3. Requested Allowable Emissions and Units:		
4. Equivalent Allowable Emissions:	lb/hour	tons/year
5. Method of Compliance (limit to 60 characters):		
6. Pollutant Allowable Emissions Comment (Desc. of Related Operating Method/Mode) (limit to 200 characters):		

B.

1. Basis for Allowable Emissions Code:		
2. Future Effective Date of Allowable Emissions:		
3. Requested Allowable Emissions and Units:		
4. Equivalent Allowable Emissions:	lb/hour	tons/year
5. Method of Compliance (limit to 60 characters):		
6. Pollutant Allowable Emissions Comment (Desc. of Related Operating Method/Mode) (limit to 200 characters):		

H. EMISSIONS UNIT POLLUTANT DETAIL INFORMATION
(Regulated Emissions Units Only - Emissions Limited Pollutants Only)

Pollutant Detail Information:

1. Pollutant Emitted: CO		
2. Total Percent Efficiency of Control:		%
3. Potential Emissions:	2.1 lb/hour	7.7 tons/year
4. Synthetically Limited? <input checked="" type="checkbox"/> Yes <input type="checkbox"/> No		
5. Range of Estimated Fugitive/Other Emissions:		
[] 1 [] 2 [] 3 _____ to _____ tons/yr		
6. Emission Factor:	0.0067 lb/hp-hr	
Reference: AP-42		
7. Emissions Method Code:		
[] 0 [] 1 [] 2 <input checked="" type="checkbox"/> 3 [] 4 [] 5		
8. Calculation of Emissions (limit to 600 characters):		
318 hp x 0.00668 lb/hp-hr = 2.12 lb/hr; 2.12 lb/hr x 7,280 hr/yr x 1 ton/2,000 lb = 7.7 TPY		
9. Pollutant Potential/Estimated Emissions Comment (limit to 200 characters):		

Emissions Unit Information Section 1 of 1
 Allowable Emissions (Pollutant identified on front page)

A.

1. Basis for Allowable Emissions Code:		
2. Future Effective Date of Allowable Emissions:		
3. Requested Allowable Emissions and Units:		
4. Equivalent Allowable Emissions:	lb/hour	tons/year
5. Method of Compliance (limit to 60 characters):		
6. Pollutant Allowable Emissions Comment (Desc. of Related Operating Method/Mode) (limit to 200 characters):		

B.

1. Basis for Allowable Emissions Code:		
2. Future Effective Date of Allowable Emissions:		
3. Requested Allowable Emissions and Units:		
4. Equivalent Allowable Emissions:	lb/hour	tons/year
5. Method of Compliance (limit to 60 characters):		
6. Pollutant Allowable Emissions Comment (Desc. of Related Operating Method/Mode) (limit to 200 characters):		

**I. VISIBLE EMISSIONS INFORMATION
(Regulated Emissions Units Only)**

Visible Emissions Limitations: Visible Emissions Limitation 1 of 1

1.	Visible Emissions Subtype: VE20
2.	Basis for Allowable Opacity: <input checked="" type="checkbox"/> Rule <input type="checkbox"/> Other
3.	Requested Allowable Opacity Normal Conditions: 20 % Exceptional Conditions: % Maximum Period of Excess Opacity Allowed: min/hour
4.	Method of Compliance: EPA Method 9
5.	Visible Emissions Comment (limit to 200 characters): Rule 62-296.320(4)(b), F.A.C.

Visible Emissions Limitations: Visible Emissions Limitation of

1.	Visible Emissions Subtype:
2.	Basis for Allowable Opacity: <input type="checkbox"/> Rule <input type="checkbox"/> Other
3.	Requested Allowable Opacity Normal Conditions: % Exceptional Conditions: % Maximum Period of Excess Opacity Allowed: min/hour
4.	Method of Compliance:
5.	Visible Emissions Comment (limit to 200 characters):

**J. CONTINUOUS MONITOR INFORMATION
(Regulated Emissions Units Only)**

Continuous Monitoring System Continuous Monitor ____ of ____

1. Parameter Code:	2. Pollutant(s):
3. CMS Requirement: [] Rule [] Other	
4. Monitor Information: Monitor Manufacturer: Model Number:	Serial Number:
5. Installation Date:	
6. Performance Specification Test Date:	
7. Continuous Monitor Comment (limit to 200 characters):	

Continuous Monitoring System Continuous Monitor ____ of ____

1. Parameter Code:	2. Pollutant(s):
3. CMS Requirement: [] Rule [] Other	
4. Monitor Information: Monitor Manufacturer: Model Number:	Serial Number:
5. Installation Date:	
6. Performance Specification Test Date:	
7. Continuous Monitor Comment (limit to 200 characters):	

**K. PREVENTION OF SIGNIFICANT DETERIORATION (PSD) INCREMENT
TRACKING INFORMATION
(Regulated and Unregulated Emissions Units)**

PSD Increment Consumption Determination

1. Increment Consuming for Particulate Matter or Sulfur Dioxide?

If the emissions unit addressed in this section emits particulate matter or sulfur dioxide, answer the following series of questions to make a preliminary determination as to whether or not the emissions unit consumes PSD increment for particulate matter or sulfur dioxide. Check the first statement, if any, that applies and skip remaining statements.

- The emissions unit is undergoing PSD review as part of this application, or has undergone PSD review previously, for particulate matter or sulfur dioxide. If so, emissions unit consumes increment.
- The facility addressed in this application is classified as an EPA major source pursuant to paragraph (c) of the definition of "major source of air pollution" in Chapter 62-213, F.A.C., and the emissions unit addressed in this section commenced (or will commence) construction after January 6, 1975. If so, baseline emissions are zero, and the emissions unit consumes increment.
- The facility addressed in this application is classified as an EPA major source and the emissions unit began initial operation after January 6, 1975, but before December 27, 1977. If so, baseline emissions are zero, and the emissions unit consumes increment.
- For any facility, the emissions unit began (or will begin) initial operation after December 27, 1977. If so, baseline emissions are zero, and emissions unit consumes increment.
- None of the above apply. If so, the baseline emissions of the emissions unit are nonzero. In such case, additional analysis, beyond the scope of this application, is needed to determine whether changes in emissions have occurred (or will occur) after the baseline date that may consume or expand increment.

2. Increment Consuming for Nitrogen Dioxide?

If the emissions unit addressed in this section emits nitrogen oxides, answer the following series of questions to make a preliminary determination as to whether or not the emissions unit consumes PSD increment for nitrogen dioxide. Check first statement, if any, that applies and skip remaining statements.

- The emissions unit addressed in this section is undergoing PSD review as part of this application, or has undergone PSD review previously, for nitrogen dioxide. If so, emissions unit consumes increment.
- The facility addressed in this application is classified as an EPA major source pursuant to paragraph (c) of the definition of "major source of air pollution" in Chapter 62-213, F.A.C., and the emissions unit addressed in this section commenced (or will commence) construction after February 8, 1988. If so, baseline emissions are zero, and the source consumes increment.
- The facility addressed in this application is classified as an EPA major source and the emissions unit began initial operation after February 8, 1988, but before March 28, 1988. If so, baseline emissions are zero, and the source consumes increment.
- For any facility, the emissions unit began (or will begin) initial operation after March 28, 1988. If so, baseline emissions are zero, and the emissions unit consumes increment.
- None of the above apply. If so, baseline emissions of the emissions unit are nonzero. In such case, additional analysis, beyond the scope of this application, is needed to determine whether changes in emissions have occurred (or will occur) after the baseline date that may consume or expand increment.

3.	Increment Consuming/Expanding Code:			
	PM	<input type="checkbox"/> C	<input type="checkbox"/> E	<input checked="" type="checkbox"/> Unknown
	SO ₂	<input type="checkbox"/> C	<input type="checkbox"/> E	<input checked="" type="checkbox"/> Unknown
	NO ₂	<input type="checkbox"/> C	<input type="checkbox"/> E	<input checked="" type="checkbox"/> Unknown
4.	Baseline Emissions:			
	PM	lb/hour		tons/year
	SO ₂	lb/hour		tons/year
	NO ₂			tons/year
5.	PSD Comment (limit to 200 characters):			

**L. EMISSIONS UNIT SUPPLEMENTAL INFORMATION
(Regulated Emissions Units Only)**

Supplemental Requirements for All Applications

1.	Process Flow Diagram	<input checked="" type="checkbox"/> Attached, Document ID: <u>Attachment A</u>	<input type="checkbox"/> Waiver Requested
		<input type="checkbox"/> Not Applicable	
2.	Fuel Analysis or Specification	<input checked="" type="checkbox"/> Attached, Document ID: <u>Attachment A</u>	<input type="checkbox"/> Waiver Requested
		<input type="checkbox"/> Not Applicable	
3.	Detailed Description of Control Equipment	<input type="checkbox"/> Attached, Document ID: _____	<input type="checkbox"/> Waiver Requested
		<input checked="" type="checkbox"/> Not Applicable	
4.	Description of Stack Sampling Facilities	<input type="checkbox"/> Attached, Document ID: _____	<input type="checkbox"/> Waiver Requested
		<input checked="" type="checkbox"/> Not Applicable	
5.	Compliance Test Report	<input type="checkbox"/> Attached, Document ID: _____	<input checked="" type="checkbox"/> Not Applicable
		<input type="checkbox"/> Previously Submitted, Date: _____	
6.	Procedures for Startup and Shutdown	<input type="checkbox"/> Attached, Document ID: _____	<input checked="" type="checkbox"/> Not Applicable
7.	Operation and Maintenance Plan	<input type="checkbox"/> Attached, Document ID: _____	<input checked="" type="checkbox"/> Not Applicable
8.	Supplemental Information for Construction Permit Application	<input checked="" type="checkbox"/> Attached, Document ID: <u>Attachment A</u>	<input type="checkbox"/> Not Applicable
9.	Other Information Required by Rule or Statute	<input checked="" type="checkbox"/> Attached, Document ID: <u>Attachment A</u>	<input type="checkbox"/> Not Applicable

Additional Supplemental Requirements for Category I Applications Only

10. Alternative Methods of Operation <input type="checkbox"/> Attached, Document ID: _____ <input type="checkbox"/> Not Applicable
11. Alternative Modes of Operation (Emissions Trading) <input type="checkbox"/> Attached, Document ID: _____ <input type="checkbox"/> Not Applicable
12. Identification of Additional Applicable Requirements <input type="checkbox"/> Attached, Document ID: _____ <input type="checkbox"/> Not Applicable
13. Compliance Assurance Monitoring Plan <input type="checkbox"/> Attached, Document ID: _____ <input type="checkbox"/> Not Applicable.
14. Acid Rain Permit Application (Hard Copy Required) <input type="checkbox"/> Acid Rain Part - Phase II (Form No. 62-210.900(1)(a)) Attached, Document ID: _____ <input type="checkbox"/> Repowering Extension Plan (Form No. 62-210.900(1)(a)1.) Attached, Document ID: _____ <input type="checkbox"/> New Unit Exemption (Form No. 62-210.900(1)(a)2.) Attached, Document ID: _____ <input type="checkbox"/> Retired Unit Exemption (Form No. 62-210.900(1)(a)3.) Attached, Document ID: _____ <input type="checkbox"/> Not Applicable

ATTACHMENT A

ATTACHMENT A

1.0 PROJECT DESCRIPTION

United States Sugar Corporation (USSC) currently controls several thousand acres of property located principally in Palm Beach, Hendry and Glades counties (see Figure 1). The majority of the property is agricultural land, such as sugar cane fields, citrus groves, and vegetable farms. Several operations are conducted in maintaining these agricultural areas, including construction and maintenance of limerock roads. From time to time, rocks and boulders are encountered in the operations, which must be removed in order to prevent damage to other operating equipment. In order to remove and dipose of the rocks and boulders, USSC utilizes a portable rock crusher.

USSC is applying for an after-the-fact construction permit for a portable rock crusher. In addition, it is requested that the initial air operating permit be issued concurrently with the construction permit. The rock crusher will be operated primarily on property controlled by USSC. The extent of USSC's property, as of 1996, is shown in Figure 1. Although this map shows the extent of USSC's property as of 1996, it is noted that USSC frequently purchases and sells property. As a result, USSC's property holdings are frequently changing, and the USSC area denoted in Figure 1 could change in the future. As shown, the vast majority of property is located in Palm Beach county, with property also in Hendry and Glades counties. The portable rock crusher may also occasionally be operated outside of USSC's property, primarily to assist other cane field or citrus grove operators.

The maximum design capacity of the rock crusher is 325 tons per hour. Current actual operating time of the rock crusher is about 6 hr/day, 5 days/week and 48 weeks per year (about 1,440 hr/yr). Maximum expected operating time is 7,280 hr/yr. Under normal operating conditions, the rock crusher will not be operated at these maximum conditions.

Manufacturer's literature and specifications for the rock crusher are contained in Attachment B. A process flow diagram for the portable rock crusher is presented in Figure 2. A schematic and dimensions of the rock crusher is also contained in the manufacturer's literature.

2.0 AIR EMISSIONS

Estimated air emissions due to the diesel-fired engine associated with the portable rock crusher are presented in Table 1. These emissions are based upon the size of the diesel engine (318 hp), expected maximum operating hours, and USEPA publication AP-42 emission factors for diesel internal combustion engines. As shown, the maximum estimated emissions for any pollutant is less than 36 tons per year (TPY).

PM/PM10 emissions from the rock crushing operations are presented in Table 2. The emissions are based upon AP-42 emission factors for the crushed stone processing industry, which specifically includes limestone crushing. Being located in south Florida, the material processed by USSC's rock crusher is primarily limestone. As shown in Table 2, the maximum estimated PM/PM10 emissions from the portable rock crusher are 0.83 TPY.

3.0 APPLICABILITY OF NSPS

Federal new source performance standards (NSPS) for nonmetallic mineral processing plants (NMMPP) have been promulgated by EPA in 40 CFR 60, Subpart OOO. The Subpart OOO NSPS is applicable to NMMPP for which construction, reconstruction or modification commenced after August 31, 1983. Nonmetallic minerals defined under the NSPS includes limestone. The NSPS applies to portable rock crushers with capacities greater than 150 tons per hour.

USSC purchased the portable rock crusher in 1973. Since this date is prior to the Subpart OOO applicability date of August 31, 1983, the NSPS does not apply to USSC's portable rock crusher.

Table 1. Potential Emissions for the Portable Rock Crusher Diesel Engine

Parameter		Specification	
OPERATING DATA			
Operating Time (hr/yr)		7,280	
Power Output (hp/hr)		318.0	
Maximum Fuel Sulfur Content (Wt %)		0.5	
Pollutant	Emission Factor ^a	No. 2 Fuel Oil	
		lb/hr	TPY
EMISSIONS DATA			
SO ₂	2.05E-03 lb/hp-hr	0.65	2.37
NO _x	0.031 lb/hp-hr	9.86	35.88
PM/PM ₁₀	2.20E-03 lb/hp-hr	0.70	2.55
CO	6.68E-03 lb/hp-hr	2.12	7.73
VOC ^b	2.51E-03 lb/hp-hr	0.80	2.91

Note: NA = not applicable.

^a Emission factors based on AP-42 Table 3.3-1.

^b VOC emissions include emissions from exhaust, evaporative, crankcase, and refueling.

Table 2. Potential PM Emissions from the Rock Crusher

OPERATING DATA		SPECIFICATION	
Operating Time (hr/yr)		7,280	
Material Throughput (ton/hr)		325	
Material Throughput (ton/yr)		2,366,000	
Activity	Emission Factor ^a	PM/PM10	
		lb/hr	TPY
EMISSIONS DATA			
Primary Crushing	7.00E-04 lb/ton	0.23	0.83

Note: NA = not applicable.

^a Emission factors based on AP-42, Table 11.19.2-2.

Table 3.3-1. EMISSION FACTORS FOR UNCONTROLLED GASOLINE AND DIESEL INDUSTRIAL ENGINES^a

Pollutant	Gasoline Fuel (SCC 2-02-003-01, 2-03-003-01)		Diesel Fuel (SCC 2-02-001-02, 2-03-001-01)		EMISSION FACTOR RATING
	Emission Factor (lb/hp-hr) (power output)	Emission Factor (lb/MMBtu) (fuel input)	Emission Factor (lb/hp-hr) (power output)	Emission Factor (lb/MMBtu) (fuel input)	
NO _x	0.011	1.63	0.031	4.41	D
CO	0.439	62.7	6.68 E-03	0.95	D
SO _x	5.91 E-04	0.084	2.05 E-03	0.29	D
PM-10 ^b	7.21 E-04	0.10	2.20 E-03	0.31	D
CO ₂ ^c	1.08	154	1.15	164	B
Aldehydes	4.85 E-04	0.07	4.63 E-04	0.07	D
TOC					
Exhaust	0.015	2.10	2.47 E-03	0.35	D
Evaporative	6.61 E-04	0.09	0.00	0.00	E
Crankcase	4.85 E-03	0.69	4.41 E-05	0.01	E
Refueling	1.08 E-03	0.15	0.00	0.00	E

^a References 2,5-6,9-14. When necessary, an average brake-specific fuel consumption (BSFC) of 7,000 Btu/hp-hr was used to convert from lb/MMBtu to lb/hp-hr. To convert from lb/hp-hr to kg/kw-hr, multiply by 0.608. To convert from lb/MMBtu to ng/J, multiply by 430. SCC = Source Classification Code. TOC = total organic compounds.

^b PM-10 = particulate matter less than or equal to 10 µm aerodynamic diameter. All particulate is assumed to be ≤ 1 µm in size.

^c Assumes 99% conversion of carbon in fuel to CO₂ with 87 weight % carbon in diesel, 86 weight % carbon in gasoline, average BSFC of 7,000 Btu/hp-hr, diesel heating value of 19,300 Btu/lb, and gasoline heating value of 20,300 Btu/lb.

Table 11.19.2-2 (English Units). EMISSION FACTORS FOR CRUSHED STONE PROCESSING OPERATIONS^a

Source ^b	Total Particulate Matter	EMISSION FACTOR RATING	Total PM-10 ^c	EMISSION FACTOR RATING
Screening (SCC 3-05-020-02,-03)	— ^d		0.015 ^c	C
Screening (controlled) (SCC 3-05-020-02-03)	— ^d		0.00084 ^c	C
Primary crushing (SCC 3-05-020-01)	0.00070 ^f	E	ND ^e	
Secondary crushing (SCC 3-05-020-02)	ND		ND ^e	
Tertiary crushing (SCC 3-05-020-03)	— ^d		0.0024 ^b	C
Primary crushing (controlled) (SCC 3-05-020-01)	ND		ND ^e	NA
Secondary crushing (controlled) (SCC 3-05-020-02)	ND		ND ^e	NA
Tertiary crushing (controlled) (SCC 3-05-020-03)	— ^d		0.00059 ^b	C
Fines crushing ^j (SCC 3-05-020-05)	— ^d		0.015	E
Fines crushing (controlled) ^j (SCC 3-05-020-05)	— ^d		0.0020	E
Fines screening ^j (SCC 3-05-020-21)	— ^d		0.071	E
Fines screening (controlled) ^j (SCC 3-05-020-21)	— ^d		0.0021	E
Conveyor transfer point ^k (SCC 3-05-020-06)	— ^d		0.0014	D
Conveyor transfer point (controlled) ^k (SCC 3-05-020-06)	— ^d		4.8x10 ⁻⁵	D
Wet drilling: unfragmented stone ^m (SCC 3-05-020-10)	ND		8.0x10 ⁻⁵	E
Truck unloading: fragmented stone ^m (SCC 3-05-020-31)	ND		1.6x10 ⁻⁵	E
Truck loading—conveyor: crushed stone ⁿ (SCC 3-05-020-32)	ND		0.00010	E

^a Emission factors represent uncontrolled emissions unless noted. Emission factors in lb/ton of material throughput. SCC = Source Classification Code. ND = no data.

^b Controlled sources (with wet suppression) are those that are part of the processing plant that employs current wet suppression technology similar to the study group. The moisture content of the study group without wet suppression systems operating (uncontrolled) ranged from 0.21 to 1.3 percent and the same facilities operating wet suppression systems (controlled) ranged from 0.55 to 2.88 percent. Due to carry over or the small amount of moisture required, it has been shown that each source, with the exception of crushers, does not need to employ direct water sprays. Although the moisture content was the only variable measured, other process features may have as much influence on emissions from a given source. Visual observations from each source under normal operating conditions are probably the best indicator of which emission factor is most appropriate. Plants that employ sub-standard control measures as indicated by visual observations should use the uncontrolled factor with an appropriate control efficiency that best reflects the effectiveness of the controls employed.

^c Although total suspended particulate (TSP) is not a measurable property from a process, some states may require estimates of TSP emissions. No data are available to make these estimates. However, relative ratios in AP-42 Sections 13.2.2 and 13.2.4 indicate that TSP emission factors may be estimated by multiplying PM-10 by 2.1.

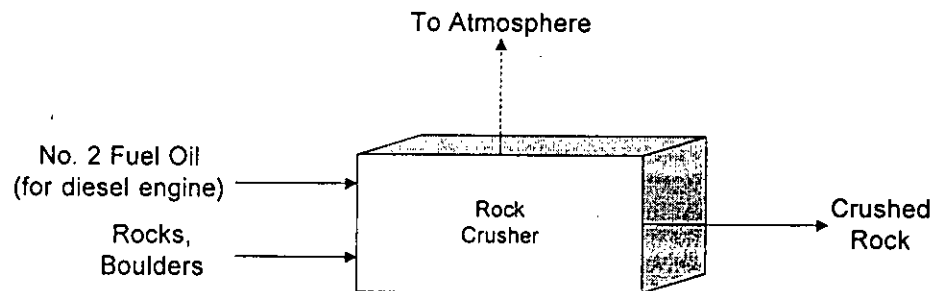

Attachment UC-EU1-L1
 U. S. Sugar Corporation
 Process Flow Diagram
 Clewiston, Florida

Process Flow Legend:
 Solid / Liquid ————▶
 Gas▶
 Steam - - - - -▶

Emission Unit: Rock Crusher

Filename: CRUSHER.VSD

Latest Revision Date: 5/15/97



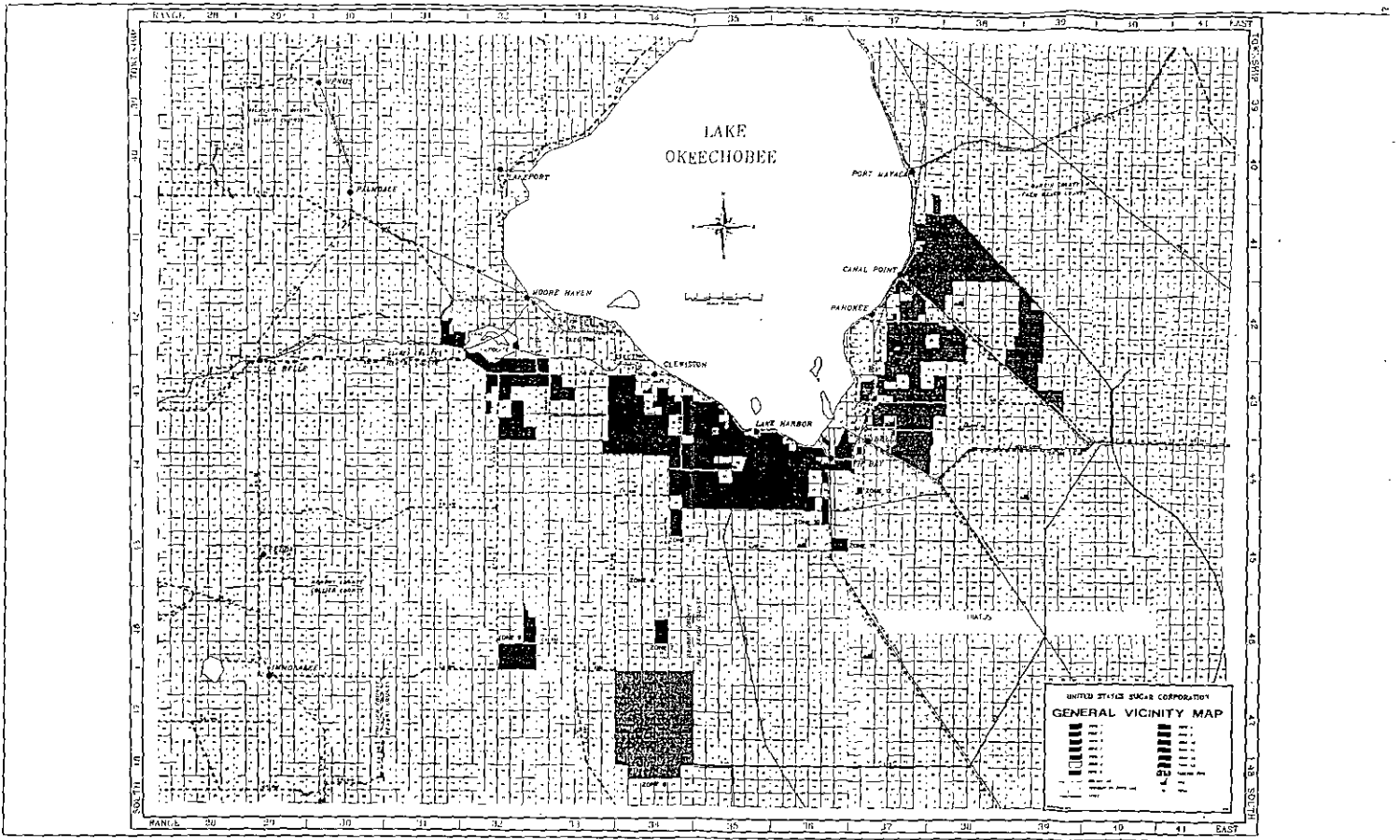

Figure 1
 Agricultural Area Under the Control of United States Sugar Corporation
 or its Subsidiaries (as of 1996)



ATTACHMENT B

SINGLE IMPELLER IMPACT BREAKER SPECIFICATIONS

1. OVERALL DIMENSIONS	3020 SECONDARY	3026 PRIMARY (Nth. Feeder)	3623 SECONDARY	3633 PRIMARY (All Feeders)	4325 SECONDARY	4326 SECONDARY	4336V† PRIMARY (Nth. Feeder)	4340 PRIMARY (All Feeders)	5348 PRIMARY (All Feeders)	6360 PRIMARY (All Feeders)
Height	80"	91 1/2"	87"	9'-4"	94"	8'-5"	9'-4"	10'-6"	12'-0"	16'-0 1/2"
Length	62 1/2"	62 1/2"	68"	68"	74 1/2"	75"	74 1/2"	75"	90"	10'-0"
Width	77"	77"	91"	91"	100"	9'-0"	100"	9'-0"	10'-0"	12'-8"
Inlet opening	30" x 20"	30" x 34"	36" x 23"	36" x 48"	43" x 25"	43" x 26"	43" x 45"	43" x 54"	53" x 69"	63" x 96"
Outlet opening	30" x 37"	30" x 37"	36" x 36"	36" x 36"	43" x 44"	43" x 46"	43" x 44"	43" x 46"	53" x 48"	63" x 90"
Weight in lbs. **	15,200	16,500	25,000	29,850	31,300	38,620	34,070	44,115	71,900	160,300
2. IMPELLERS										
Total weight with shaft and bars	4,575	4,575	6,725	6,725	10,180	10,700	10,160	10,700	17,440	35,700
Dia. outside bars	35 1/2"	35 1/2"	37 1/2"	37 1/2"	42 1/2"	42 1/2"	42 1/2"	42 1/2"	49 1/2"	59 1/2"
Core (material)	Cast Ni Steel	Cast Ni Steel	Cast Ni Steel	Cast Ni Steel	Cast Ni Steel	Cast Ni Steel	Cast Ni Steel	Cast Ni Steel	Cast Ni Steel	Cast Ni Steel
Weight	3,180	3,180	4,600	4,600	7,525	8,360	7,525	8,360	12,570	26,300
Impeller Bars	Manganese	Manganese	Manganese	Manganese	Manganese	Manganese	Manganese	Manganese	Manganese	Manganese
Weight	390	390	430	430	530	530	530	530	720	870
Number	2	2	2	2	2	2	2	2	3	3
Wearing Surfaces	1	1	1	1	1	1	1	1	1	1
3. SHAFTS										
Dia. through Impeller	4 1/2"	4 1/2"	6 1/2"	6 1/2"	6 1/2"	7 1/2"	6 1/2"	7 1/2"	10"	14 1/2"
Dia. at ends	3 1/2"	3 1/2"	4 1/2"	4 1/2"	4 1/2"	5 1/2"	4 1/2"	5 1/2"	7"	11 1/2" paper
Keyways at ends	7/8" Sq.	7/8" Sq.	1 1/2" Sq.	1 1/2" Sq.	1 1/2" Sq.	1 1/2" Sq.	1 1/2" Sq.	1 1/2" Sq.	1 1/2" Sq.	3" x 1"
4. BEARINGS --- Heavy Duty, Spherical Double Row Self Aligning										
5. BREAKER BAR										
Material	1045 H.R.S.	1045 H.R.S.	1045 H.R.S.	1045 H.R.S.	1045 H.R.S.	1045 H.R.S.	1045 H.R.S.	1045 H.R.S.	1045 H.R.S.	Hi. Carb. Steel
Diameter	5"	5"	6 1/2"	6 1/2"	6 1/2"	6 1/2"	6 1/2"	6 1/2"	8"	10 1/2"
6. SLEEVES										
Material	Manganese	Manganese	Manganese	Manganese	Manganese	Manganese	Manganese	Manganese	Manganese	Manganese
Diameter	7"	7"	9"	9"	9"	9"	9"	9"	12"	16 1/2"
7. LINER PLATES										
Material	Mang.-A.R.S.	Mang.-A.R.S.	Mang.-A.R.S.	Mang.-A.R.S.	Mang.-A.R.S.	Mang.-A.R.S.	Mang.-A.R.S.	Mang.-A.R.S.	Mang.-A.R.S.	Mang.-A.R.S.
Thickness	1"	1"	1"	1"	1 1/2"	1 1/2"	1 1/2"	1 1/2"	3 1/2"	1 1/2"
8. SIDE PLATES										
Material	H. R. S.	H. R. S.	H. R. S.	H. R. S.	H. R. S.	H. R. S.	H. R. S.	H. R. S.	H. R. S.	H. R. S.
Thickness	1 1/2"	1 1/2"	1 1/2"	1 1/2"	2"	2"	2"	2"	3"	4"
9. H. P. REQUIREMENTS --- For Maximum Output										
HP***	125-150	125-150	150-200	150-200	250-300	250-300	250-300	250-300	300-400	500-600
R.P.M. Breaker	350-550	350-550	350-575	350-575	350-650	350-650	350-650	350-650	350-500	300-450
R.P.M. Motor	900-1400	900-1400	900-1200	900-1200	900-1200	900-1200	900-1200	900-1200	900-1200	900-1200
10. MINIMUM PRODUCT SIZE --- Dependent on Type and Characteristics of Material Processed										
Practical minimum size	1 1/2" Minus	1 1/2" Minus	1 1/2" Minus	1 1/2" Minus	2" Minus	2" Minus	2" Minus	2" Minus	3" Minus	6" Minus
Closed Circuit	100-200	100-200	200-350	200-350	250-500	250-500	250-500	250-500	500-1000	1000-1500
Tons per hour	100-200	100-200	200-350	200-350	250-500	250-500	250-500	250-500	500-1000	1000-1500
11. CAPACITIES --- Dependent on Type and Characteristics of Material Processed										

Specifications Subject to Change Without Notice.

*Maximum without feeder. Breakers will accept feed size according to model designation. For example, a Model 3633 will accept rock of maximum size of 36" x 36".
 **Weights do not include feed chute, chain curtain, discharge chute, drives or std.
 ***If new frame motors are used, increase electric HP requirements by 25%.
 †Model 4336A (Apron Feeder) height 10'-2", weight 36,050 lbs. All other data applies.

Specifications subject to change without notice.



IOWA MANUFACTURING COMPANY

CEDAR RAPIDS, IOWA • U.S.A. • 52402



SPECIFICATIONS

**SINGLE IMPELLER
IMPACT BREAKER**

**ENGINEERED
FOR GREATER
PRODUCTION
OF SPECIFICATION
MATERIALS**

Use engineering drawings for installation purposes.

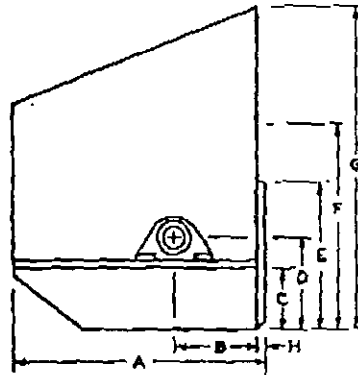

MODELS — 3020 & 4325

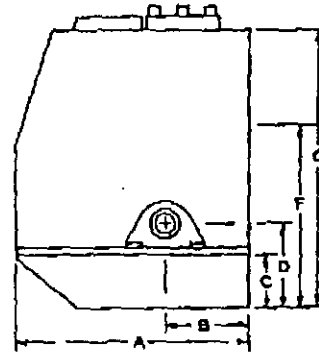

MODELS — 3623, 3633, 4326,
4340, 5348 & 6360

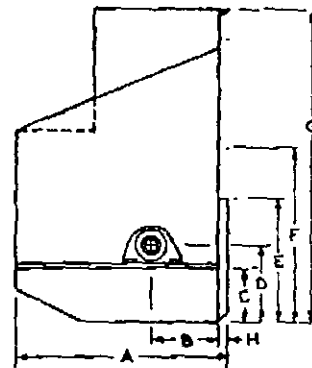

MODELS — 3026, 4336A (VIBRATING FEEDER)
---- 4336 (APRON FEEDER)

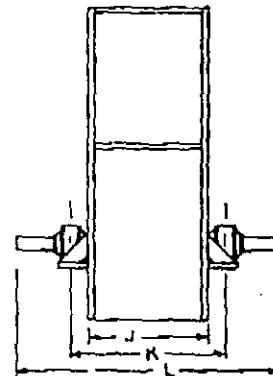

ALL MODELS — END VIEW

DIMENSIONS All dimensions in inches unless noted.

Model	A	B	C	D	E	F***	G	H	J	K	L
3020	62 1/2	20	15 1/2	21 1/2	36	50 1/2	80	2 1/2	35	45 1/2	77
3026**	62 1/2	24	15 1/2	21 1/2	36	50 1/2	91 1/2	2 1/2	35	45 1/2	77
3623	68	24	15 1/2	23 1/2	—	53	87	—	41	54	91
3633	68	24	15 1/2	23 1/2	—	53	9'-4"	—	41	54	91
4325	74 1/2	24	18	26 1/2	43	59 1/2	94	2 1/2	50	64	100
4326	75	27	18	27 1/2	—	59 1/2	8'-5"	—	50	64	9'-0"
4336**	74 1/2	24	18	26 1/2	43	59 1/2	9'-4"	2 1/2	50	64	100
4336*	74 1/2	24	18	26 1/2	43	59 1/2	10'-2"	2 1/2	50	64	100
4340	75	27	18	27 1/2	—	59 1/2	10'-6"	—	50	64	9'-0"
5348	90	30	18	30 1/2	—	62 1/2	12'-0"	—	62	80	10'-0"
6360	120	42	25	43	—	82 1/2	16'-0 1/2"	—	74	94	12'-8"

*Model 4336 available with apron feeder.

**Models 4336 and 3026 available with vibrating feeder. Models 5348 and 3633 available with all feeders.

***Dimension "F" to bottom of feed opening.

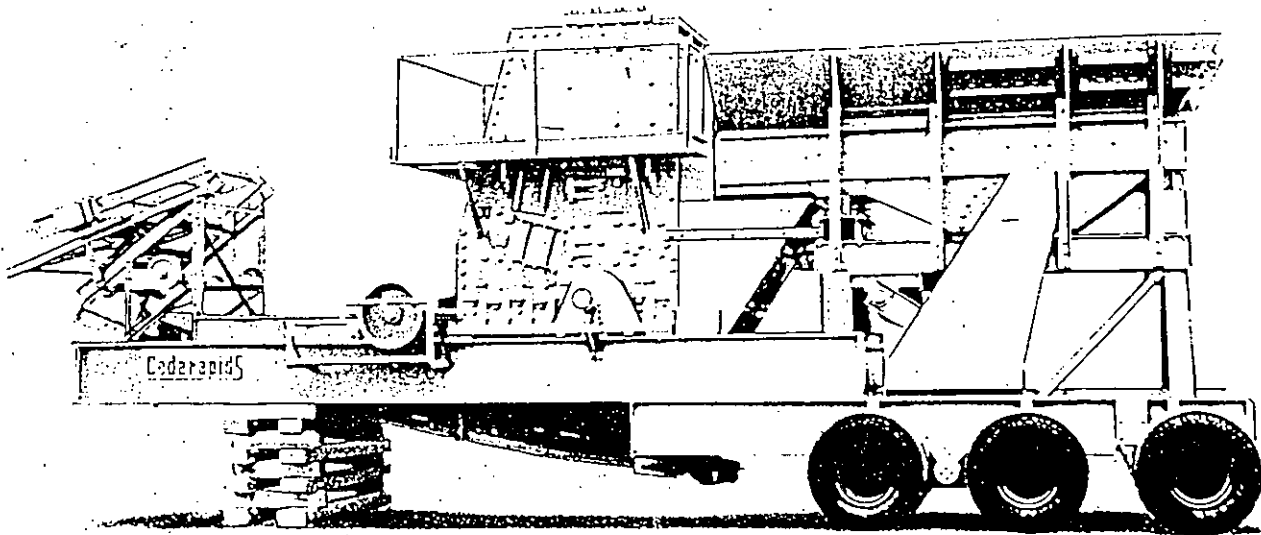

Single Impeller Primary with 15' Vibrating Scalping Feeder

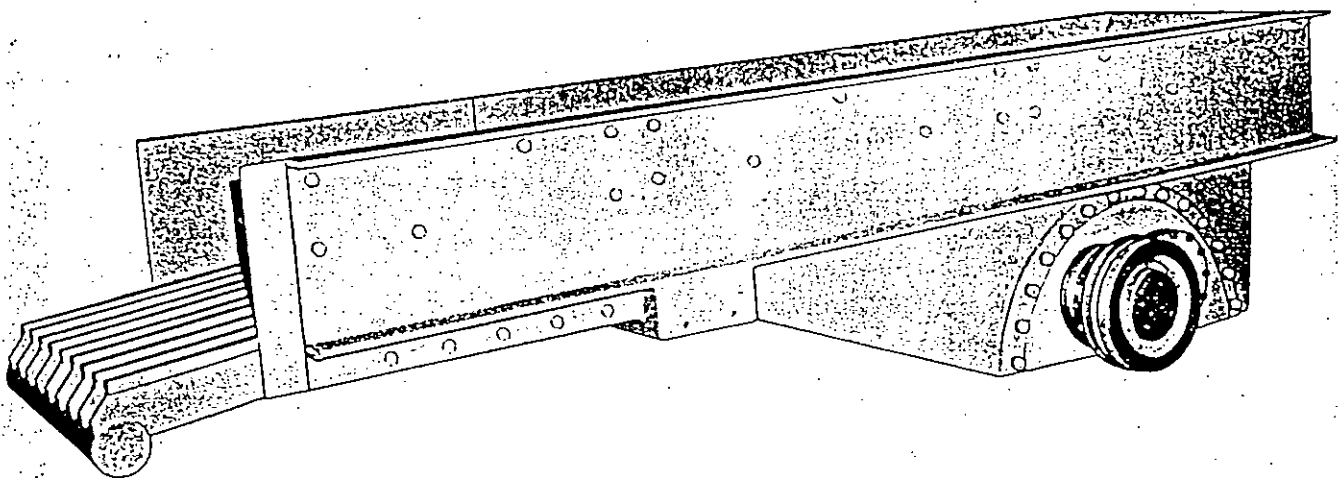

View of 12' Vibrating Scalping Feeder

VIBRATING FEEDER BOX

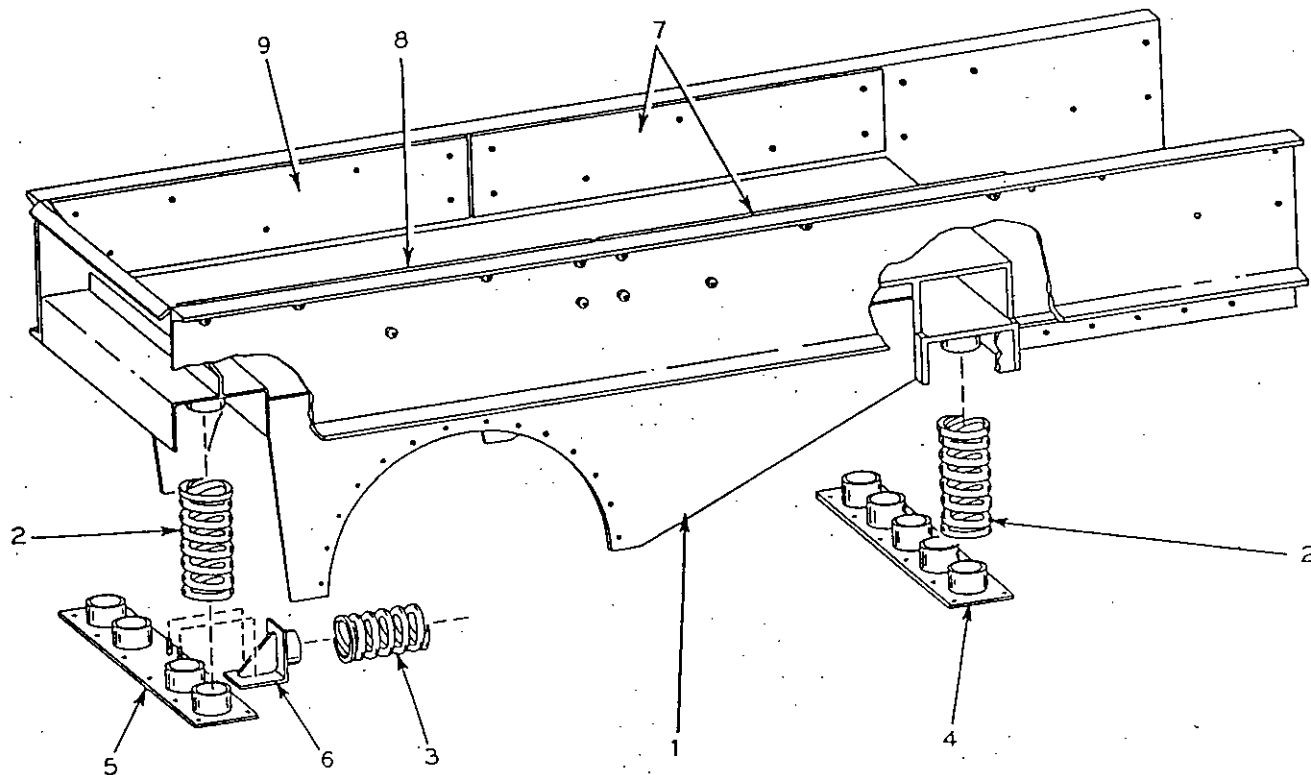

Ref. No.	Description	Quantity
1	Box, Feeder	1
2	Spring	Variable
3	Spring	1
4	Guide, Spring—Front	1
5	Guide, Spring—Rear	1
6	Guide, Spring—Horizontal	1
*7	Liner, Center	2
8	Liner, Rear—RH	1
9	Liner, Rear—LH	1

*Liner not used on 10'-6" feeders.

Figure 3

DESCRIPTION	DATE	GROSS AMOUNT	DISCOUNT	NET AMOUNT
6203052297 482280	05/22/97	2000.00	0.00	2000.00
		-----	-----	-----
		2000.00	0.00	2000.00

DETACH ALONG PERFORATION

DETACH ALONG PERFORATION

THIS CHECK IS VOID IF BLUE COLORED BACKGROUND IS ABSENT



United States Sugar Corporation
 P.O. Drawer 1207
 Clewiston, FL 33440
 (941) 983-8121

First Union National Bank
 of Florida
 Pensacola, FL 32534

63-1012 CHECK NO. **00834090**
 632

DATE
05/27/97



PAY TO THE ORDER OF TWO THOUSAND DOLLARS AND 00 CENTS *****

AMOUNT
 *****\$2,000.00

TO THE ORDER OF
 FL DEPARTMENT OF ENVIRONMENTAL PROTECTION - SOUTH DISTRICT
 2295 VICTORIA AVE. SUITE 364
 FORT MYERS FL 33901-3881

Robert [Signature]

VOID OVER \$2,000.00

⑈00834090⑈ ⑆063210125⑆ 2079900151774⑈