



Florida Gas Transmission Company

A Southern Union/El Paso Affiliate

5444 Westheimer Road
Houston, TX 77056-5306

P.O. Box 4967
Houston, TX 77210-4967
713.989.7000

November 26, 2008

UPS Overnight

~~CERTIFIED MAIL - RETURN RECEIPT~~

Ms. Trina Vielhauer, Chief
Bureau of Air Regulation
Florida Department of Environmental Protection
2600 Blairstone, MS 5500
Tallahassee, FL 32399-2400
Phone: 850-921-9504

RECEIVED

NOV 26 2008

BUREAU OF AIR REGULATION

Reference: Facility: 1230034

Compressor Station No. 15, Taylor County

Project No. : 1230034-018-AC

Dear Ms. Vielhauer:

Subject: Application for Air Construction Permit

Florida Gas Transmission Company (FGT) is proposing to install a new emergency generator at the above referenced facility.

Enclosed is an Application with supporting documentation for an Air Construction Permit for the proposed modifications. FGT understands that no processing fee is required since this facility is operated under a Part 70 Permit.

If you have any questions or need additional information, please call me at (713) 989-7459.

Sincerely,

Charles Wait
Principal Engineer



CC: Arnold L. Eisenstein
Frank Diemont
Kevin McGlynn, P.E.
Duane Pierce, AQMcs, LLC
Compressor Station No. 15



Application for Air Permit to Construct

**Florida Gas Transmission Company, LLC
Phase VIII Expansion Project
Perry Compressor Station No. 15
Perry, Taylor County, Florida
Facility No. 1230034**

November 2008

AQMcs

Table of Contents

1.0	INTRODUCTION.....	1
2.0	PROJECT DESCRIPTION.....	3
2.1	<i>Existing Operations</i>	3
2.2	<i>Proposed Modification</i>	3
2.2.2	<i>New Emergency Generator</i>	3
2.2.3	<i>Fugitive Emissions</i>	3
2.2	<i>Emissions Summary</i>	6
3.0	REGULATORY ANALYSIS.....	7
3.2	<i>Federal Regulations Review</i>	7
3.1.1	<i>PSD Applicability</i>	7
3.1.2	<i>Non-attainment New source Review (NNSR) Applicability</i>	8
3.1.3	<i>Applicability of New source Performance Standards (NSPS)</i>	8
3.1.4	<i>Applicability of National Emission Standards for Hazardous Air Pollutants (NESHAPS)</i>	9
3.2	<i>Florida state air Quality Regulations</i>	9
3.2.1	<i>Rule 62-210.300 Permits Required</i>	10
3.2.2	<i>Rule 62-204.240 Ambient Air Quality Standards</i>	10
3.2.3	<i>Rule 62-296.320(2) Objectionable Odors</i>	10
3.2.4	<i>Rule 62-296.320(4)(b)1 General Particulate Emission Limiting Standards</i>	10
4.0	REFERENCES.....	11

Attachment A	DEP Forms
Attachment B	Process Flow Diagram
Attachment C	Precautions to Prevent Emissions of Unconfined Particulate Matter
Attachment D	Plot Plan
Attachment E	Vendor Information
Attachment F	Calculations
Attachment G	Fuel Analysis
Attachment H	Exempt Sources List

AQMcs

List of Tables

Table 2-1 Proposed Emergency Generator Engine Specifications and Stack Parameters	.4
Table 2-2 Emissions from Each Proposed Generator Engine	5
Table 2-3 VOC Fugitive Emission Calculations and Summary	6
Table 3-1 Applicability of New Source Performance Standards Subpart JJJJ.....	9

List of Figures

Figure 1-1 Location Map.....	2
------------------------------	---

1.0 INTRODUCTION

Florida Gas Transmission Company (FGT) is proposing to expand its existing natural gas pipeline facility near Perry, in Taylor County, Florida (Compressor Station No. 15). This proposed modification is part of FGT's Phase VIII Expansion Project, aimed at increasing the supply capacity of FGT's network servicing domestic suppliers, commercial, and industrial customers in Florida. The scope of work for the Phase VIII Expansion Project includes expansion through the addition of state-of-the-art compressor engines at nine existing compressor stations within the States of Florida and Alabama. Three compressor stations within Florida will receive electric driven turbine compressors and five compressor stations within Florida will receive natural gas-fired turbine compressors.

Compressor Station No. 15 is located in Taylor County, Florida, on Pisgah Road approximately 1 mile east of U.S. Highway 19. Figure 1-1 shows the location of the existing compressor station.

FGT is proposing to add a new emergency generator with catalytic converter at this facility. This new generator will be powered by a 223 bhp, gas-fired reciprocating compressor engine. This engine will be subject to the requirements of 40 CFR Subpart JJJJ.

This narrative contains three additional sections. Descriptions of the existing operation at FGT's Compressor Station No. 15 and the proposed new emergency generator are presented in Section 2.0. The air quality review requirements and applicability of state and federal regulations are discussed in Section 3.0. References are included in Section 4.0. FDEP permit application forms are provided in Attachment A. Attachment B contains a process flow diagrams and Attachment C contains Precautions to Prevent Emissions of Unconfined Particulate Matter. A plot plan of the facility is located in Attachment D. Attachment E contains vendor information and Attachment F contains emission calculations. Attachment G provides a fuel analysis and Attachment H has a list of exempt sources.

Figure 1-1 Location Map

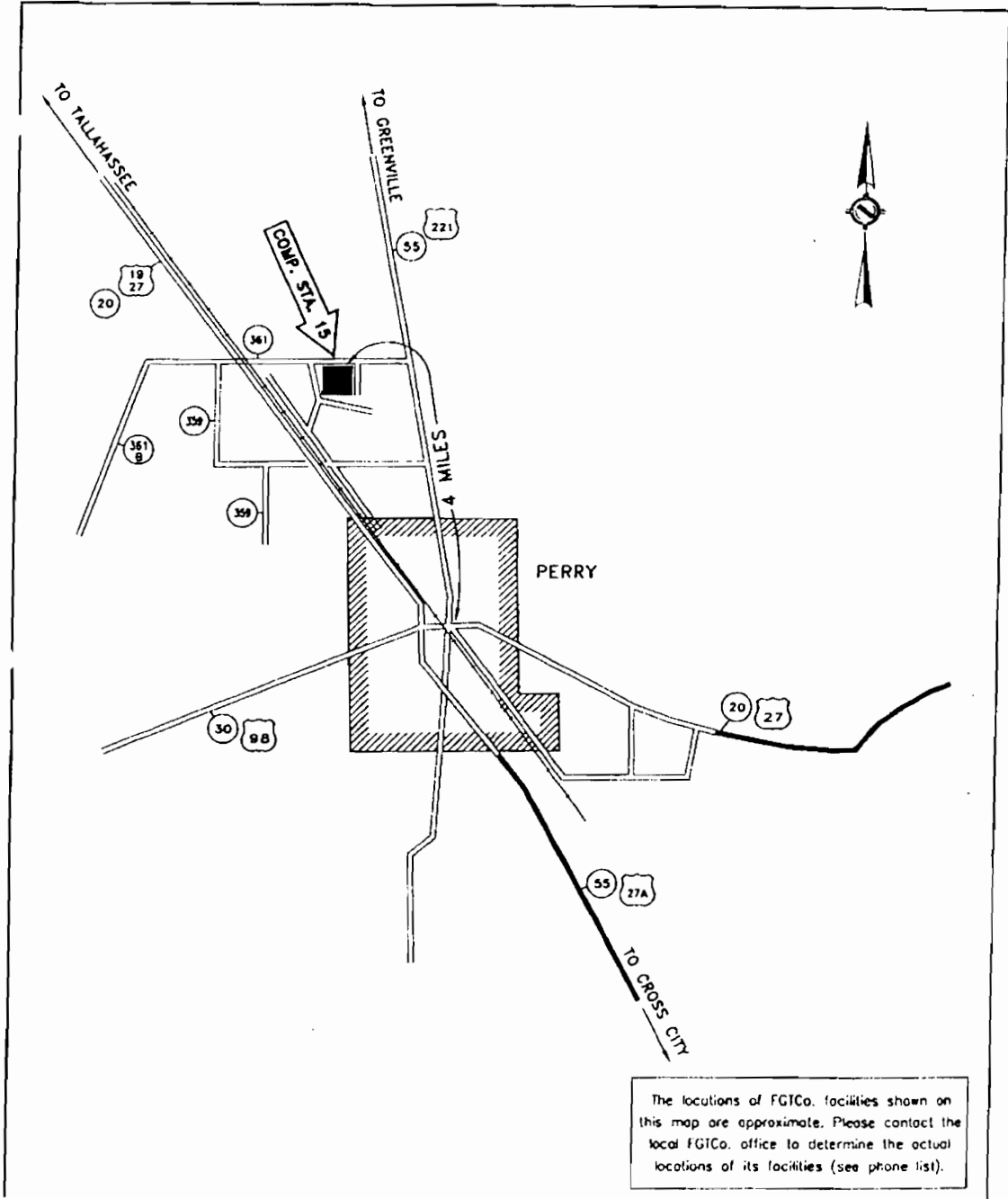

PLOT NO. 04/26/2000 FILE NAME: 4625TA15.DWG		P.L. STA. NO. CONSTRUCTION TR. 2000 DESIGNED BY DRAWN GDS 10/11/99 ASSEMBLED FILE NO. SCALE NAME Florida Gas Transmission Co. Houston, Texas	COMPRESSOR STATION NO. 15 FGT PHASE V EXPANSION VICINITY MAP TAYLOR COUNTY, FLORIDA	P.L. WORK ORDER 539940 NUMBER ONE NO. CONSTRUCTION SHEET NO. STA. 15 SHEET 1 OF 1
--	--	--	--	---

2.0 PROJECT DESCRIPTION

A plot plan of FGT's Compressor Station No. 15, showing the location of the plant boundaries, and the location of the new generator is presented in Attachment B. The following sections provide a description of the existing operations at this location, as well as a description of the proposed project.

2.1 Existing Operations

FGT's existing Compressor Station No. 15 emission sources include five 2,000 bhp and one 4,000 bhp natural-gas-fired reciprocating internal combustion (IC) engines. Compressor Station No. 15 also has one 15,000 bhp gas-fired turbine and one 7,222 bhp gas-fired turbine. The existing facility also has supporting equipment including lube and used oil storage tanks, air compressors and emergency generators.

2.1 Proposed Modification

FGT proposes to install a new emergency generator. The generator will be powered by a 223 bhp, gas-fired, 4-stroke, rich burn reciprocating compressor engine with emissions that will be controlled to meet the new 40 CFR Subpart JJJJ standards as required. Details of the changes are described in the following sections. Additionally, an electric motor driven natural gas compressor is being installed at the facility. The motor itself produces no emissions and does not require a construction permit. However, there is a minor change to the fugitive emissions as discussed below.

2.2.2 New Emergency Generator

The new generator will be powered by natural gas fueled, rich burn Generac Model SG150 rated at 150 kW (223 bhp). Engine specifications and stack parameters for the proposed engines are presented in Table 2-1 and emissions are presented in Table 2-2.

2.2.3 Fugitive Emissions

Potential new emissions from Compressor Station No. 15 also include fugitive emissions from the new valves and flanges that will be in gas service. These fugitive emissions have been estimated using USEPA factors for components in gas service at oil and gas facilities (EPA publication EPA-453/R-95-017, November 1995, "Protocol for Equipment Leak Emission

Estimates"). Table 2-3 lists the quantities new components to be added as part of the Phase VIII Expansion Project and an estimate of the fugitive emissions from these sources. These emissions are exempt under Rule 62-210.300(3)(b), F.A.C.

Table 2-1 Proposed Emergency Generator Engine Specifications and Stack Parameters

Parameter	Design
Compressor Engine	Gen 04
Type	Natural Gas, Rich Burn Reciprocating
Manufacturer	Generac
Model	SG150
Unit Size	223 bhp
Heat Input	2.49 MM Btu/hr
Fuel Consumption ^a	0.002395 MMscf/h
Speed	2760 rpm
Stack Parameters	
Stack Height	20 ft
Stack Diameter	0.67 ft
Exhaust Gas Flow	1560 acfm
Exhaust Gas Flow	1500 °F
Exhaust Temperature	74.5 ft/sec
Exhaust Gas Velocity	
<p>NOTE:</p> <p>acfm = actual cubic feet per minute.</p> <p>bhp = brake horsepower.</p> <p>Btu/hr = British thermal units per hour.</p> <p>°F = degrees Fahrenheit.</p> <p>ft = feet.</p> <p>ft/sec = feet per second.</p> <p>Lb/hr = pound per hour.</p> <p>rpm = revolutions per minute.</p> <p>scf/h = standard cubic feet per hour</p> <p>^a Based on heating value for natural gas of 1040 British thermal units per standard cubic foot (Btu/scf).</p>	

Table 2-2 Emissions from Each Proposed Generator Engine

Pollutant	Controlled			
	Emission Factor	lb/hr ^a	TPY ^{a, b}	Reference
Nitrogen Oxides	2.0 g/hp-hr	0.98	0.05	NSPS Supart JJJJ
Carbon Monoxide	4.0 g/hp-hr	1.97	0.10	NSPS Supart JJJJ
Volatile Organic Compounds ^c	1.0 g/hp-hr	0.49	0.02	NSPS Supart JJJJ
Particulate Matter	0.01941 lb/MMBtu	0.048	0.002	AP-42, Table 3.2-3
Sulfur Dioxide	10 grains/100 scf	0.068	0.003	FERC Limit
Hazardous Air Pollutants	0.0234 lb/MMBtu	0.058	0.003	AP-42, Table 3.2-3

- a. The manufacturer has not finalized design at this time. Actual values may be lower.
- b. Based on 454 bhp, 100 hours of operation per year
- c. assumed VOC 10% of UHC/THC

Table 2-3 VOC Fugitive Emission Calculations and Summary

Component	Service	Component	Emissions *	NM/NE	Emissions
		Count	Factor (ton/yr)	Fraction	(ton/yr)
Valves	Gas	56	0.0434606	0.05	0.1217
Connector	Gas	0	0.0019316	0.05	0.0000
Flanges	Gas	116	0.0037666	0.05	0.0218
Open-Ended Line	Gas	0	0.0193158	0.05	0.0000
Pumps	Gas	0	0.023179	0.05	0.0000
Other	Gas	0	0.0849895	0.05	0.0000
Valves	Light Oil	0	0.0241448	1.00	0.0000
Connector	Light Oil	0	0.0020282	1.00	0.0000
Flanges	Light Oil	0	0.0010624	1.00	0.0000
Open-Ended Line	Light Oil	0	0.0135211	1.00	0.0000
Pumps	Light Oil	0	0.1255527	1.00	0.0000
Other	Light Oil	0	0.0724343	1.00	0.0000
Valves	Heavy Oil	0	0.0000811	1.00	0.0000
Connector	Heavy Oil	0	0.0000724	1.00	0.0000
Flanges	Heavy Oil	0	0.0000038	1.00	0.0000
Open-Ended Line	Heavy Oil	0	0.0013521	1.00	0.0000
Other	Heavy Oil	0	0.0002994	1.00	0.0000
				TOTAL:	0.1435

*EPA publication EPA-453/R-95-017, November 1995, "Protocol for Equipment Leak Emission Estimates"

2.1 Emissions Summary

The total changes in emissions resulting from the project are those listed as controlled emissions in Table 2-2. The calculations used to estimate these emissions are presented in Attachment F.

3.0 REGULATORY ANALYSIS

This section presents a review of federal and Florida State air quality regulations, which govern the operations and proposed modifications to be conducted at Compressor Station No. 15.

3.1 Federal Regulations Review

The federal regulatory programs administered by the USEPA have been developed under the authority of the Clean Air Act. The following subsections review the essential elements of the federal regulatory program and the impact they have on the operations and proposed modifications at Compressor Station No. 15.

3.1.1 PSD Applicability

The 1977 CAA Amendments added Part C: Prevention of Significant Deterioration to the Act. This part required proposed new major stationary sources or existing sources planning a major modification in an area that has attained the National AAQS, to conduct a preconstruction review that includes a detailed analysis of the impacts from the source's emissions.

Federal air quality permitting regulations for attainment areas are codified in the Code of Federal Regulations (CFR), Title 40- Protection of the Environment, Part 52.21 - Prevention of Significant Deterioration (40 CFR 52.21). Major revisions to the rules were finalized on December 31, 2002, and became effective on March 3, 2003. State of Florida requirements are located at 62-212.400 F.A.C.

For the PSD regulations to apply to a given project, the project's potential to emit must constitute a new major stationary source or a major modification to an existing major stationary source. A major stationary source is defined as any of the 28 sources identified in 40 CFR 52.21 that has a potential to emit 100 tons or more per year of any regulated pollutant, or any other stationary source that has the potential to emit 250 tons or more per year of a regulated pollutant. "Potential to emit" is determined on an annual basis after the application of air pollution control equipment, or any other federally enforceable restriction.

Since Compressor Station No. 15 is not one of the 28 named source categories, but does emit >250 TPY of at least one regulated pollutant, it is considered a major source. However, the increase in emissions resulting from the proposed actions will not exceed the PSD significant rates; therefore, the compressor station is not subject to PSD pre-construction review

3.1.2 Non-attainment New source Review (NNSR) Applicability

Based on the current non-attainment provisions, all new major stationary sources, or major modifications to such sources, located in a non-attainment area must undergo non-attainment New Source Review, if they have the potential to emit above an NSR significant threshold. For major new sources or major modifications in an attainment or unclassifiable area, the non-attainment provisions apply if the source or modification is located within the area of influence of a non-attainment area. The area of influence is defined as an area, which is outside the boundary of a non-attainment area, but within the locus of all points that are 50 kilometers outside the non-attainment area.

Compressor Station No. 15 is located in an area that is designated as either attainment or not classifiable for all criteria pollutants and is not located in an area of influence outside a non-attainment area. Therefore, this compressor station is not subject to federal non-attainment New Source Review.

3.1.3 Applicability of New source Performance Standards (NSPS)

Standards of Performance for New Sources are published in 40 CFR 60. All Standards apply to all new sources within a given category, regardless of geographic location or ambient air quality at the location.

40 CFR 60 Subpart JJJJ

The new emergency generator engine is subject to 40 CFR Subpart 60 Subpart JJJJ Standards of Performance for Stationary Spark Ignition Internal Combustion Engines. Owners and operators of stationary spark ignition internal combustion engines with maximum engine power greater than or equal to 100 hp must comply with the standards for NOX, CO and VOC established in Table 1 of Subpart JJJJ. The proposed generator engines will comply with the applicable standards. FGT will also be required to comply with all recordkeeping and monitoring requirements of this regulation.

Table 3-1 summarizes the NSPS applicability for the proposed gas-fired emergency generator engines.

Table 3-1 Applicability of New Source Performance Standards Subpart JJJJ

NESHAP Regulations	Fuel	Pollutant	Equipment Design Maximum	NSPS Emission Limits (g/hp-hr)	Equipment Emissions (G/hp-hr)
60.4230 Table 1	Gas	NO ₂	100 hp and higher	2.0	2.0
60.4230 Table 1	Gas	CO	100 hp and higher	4.0	4.0
60.4230 Table 1	Gas	VOC	100 hp and higher	1.0	1.0

3.1.4 Applicability of National Emission Standards for Hazardous Air Pollutants (NESHAPS)

Section 112 of the Clean Air Act required the USEPA to list categories and subcategories of major sources and area sources of hazardous air pollutants (HAP) and to establish NESHAPS for the listed source categories and subcategories. NESHAPS require all major sources to meet HAP emission standards reflecting the application of the maximum achievable control technology (MACT).

Compressor Station 15 is a major source of HAPS and is, therefore, subject to any applicable NESHAPS. The new emergency generator engine is subject to 40 CFR 63 Subpart ZZZZ - National Emission Standard for Hazardous Air Pollutants: Reciprocating Internal Combustion Engines. Engines in compliance with the New Source Performance Standards at 40 CFR Subpart 60 Subpart JJJJ are considered to be in compliance with 40 CFR 63 Subpart ZZZZ. Since the proposed new emergency generator engines will meet the standards of 40 CFR 60 Subpart JJJJ, they will also comply with the requirements of 40 CFR 63 subpart ZZZZ.

The only other NESHAPS that is potentially applicable to this compressor station is 40 CFR 63 Subpart HHH. Compressor Station No. 15 has no affected sources as defined by 40 CFR 63 Subpart HHH and is, therefore, not subject to this subpart.

3.2 Florida State Air Quality Regulations

Compressor Station No. 15 is currently operating under Permit No.1230034-016-AV and is subject to the provisions of that permit. Rule 62, F.A.C., contains the air quality rules and regulations for the State of Florida. The primary federal regulations that affect Compressor Station No. 15 have been incorporated into or are referenced by these rules. The significant

state regulations that are applicable to the new emission units are briefly listed below.

3.2.1 Rule 62-210.300 Permits Required

FGT is required to obtain a construction permit prior to modification of an emission unit. This requirement is being met by the submittal of this application.

3.2.2 Rule 62-204.240 Ambient Air Quality Standards

FGT must not violate any of the ambient air quality standards listed under this rule. The proposed new emissions will not violate any air quality standards.

3.2.3 Rule 62-296.320(2) Objectionable Odors

This rule prohibits the discharge of pollutants that will cause or contribute to an objectionable odor. There will be no odors from the proposed changes.

3.2.4 Rule 62-296.320(4)(b)1 General Particulate Emission Limiting Standards

FGT is prohibited from allowing the new compressor engine to discharge into the atmosphere the emissions of air pollutants, the density of which is equal to or greater than that designated as Number 1 on the Ringelmann Chart (20 percent opacity). The new engines will not violate this standard.



4.0 REFERENCES

U.S. Environmental Protection Agency (USEPA). 1980. PSD Workshop Manual. Research Triangle Park, NC.

U.S. Environmental Protection Agency (USEPA). 1985. Protocol for Equipment Leak Emission Estimates, EPA-453/R-95-017

U.S. Environmental Protection Agency (USEPA). 2000. Compilation of Air Pollutant Emission Factors, Volume I: Stationary Point and Area Sources (5th Ed.) AP-42. Supplement E, Research Triangle Park, NC.



Attachment A

DEP Forms

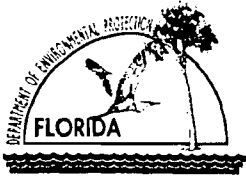

Department of Environmental Protection

Division of Air Resource Management

APPLICATION FOR AIR PERMIT - LONG FORM

RECEIVED
NOV 26 2008
BUREAU OF AIR REGULATION

I. APPLICATION INFORMATION

Air Construction Permit – Use this form to apply for an air construction permit:

- For any required purpose at a facility operating under a federally enforceable state air operation permit (FESOP) or Title V air operation permit;
- For a proposed project subject to prevention of significant deterioration (PSD) review, nonattainment new source review, or maximum achievable control technology (MACT);
- To assume a restriction on the potential emissions of one or more pollutants to escape a requirement such as PSD review, nonattainment new source review, MACT, or Title V; or
- To establish, revise, or renew a plantwide applicability limit (PAL).

Air Operation Permit – Use this form to apply for:

- An initial federally enforceable state air operation permit (FESOP); or
- An initial, revised, or renewal Title V air operation permit.

To ensure accuracy, please see form instructions.

Identification of Facility

1. Facility Owner/Company Name: Florida Gas Transmission Company, LLC	
2. Site Name: Compressor Station No. 15	
3. Facility Identification Number: 1230034	
4. Facility Location... Street Address or Other Locator: 2065 Pisgah Road, CR 361 City: Perry County: Taylor Zip Code: 32347	
5. Relocatable Facility? <input type="checkbox"/> Yes <input checked="" type="checkbox"/> No	6. Existing Title V Permitted Facility? <input checked="" type="checkbox"/> Yes <input type="checkbox"/> No

Application Contact

1. Application Contact Name: Charles Wait	
2. Application Contact Mailing Address... Organization/Firm: Florida Gas Transmission Company, LLC Street Address: 5444 Westheimer City: Houston State: TX Zip Code: 77056	
3. Application Contact Telephone Numbers... Telephone: (713) 989 - 7459 ext. Fax: (713) 989 - 1135	
4. Application Contact E-mail Address: charles.wait@SUG.com	

Application Processing Information (DEP Use)

1. Date of Receipt of Application: 11-26-08	3. PSD Number (if applicable):
2. Project Number(s): 1230034-018-AC	4. Siting Number (if applicable):

APPLICATION INFORMATION

Purpose of Application

This application for air permit is being submitted to obtain: (Check one)

Air Construction Permit

- Air construction permit.
- Air construction permit to establish, revise, or renew a plantwide applicability limit (PAL).
- Air construction permit to establish, revise, or renew a plantwide applicability limit (PAL), and separate air construction permit to authorize construction or modification of one or more emissions units covered by the PAL.

Air Operation Permit

- Initial Title V air operation permit.
- Title V air operation permit revision.
- Title V air operation permit renewal.
- Initial federally enforceable state air operation permit (FESOP) where professional engineer (PE) certification is required.
- Initial federally enforceable state air operation permit (FESOP) where professional engineer (PE) certification is not required.

Air Construction Permit and Revised/Renewal Title V Air Operation Permit (Concurrent Processing)

- Air construction permit and Title V permit revision, incorporating the proposed project.
- Air construction permit and Title V permit renewal, incorporating the proposed project.

Note: By checking one of the above two boxes, you, the applicant, are requesting concurrent processing pursuant to Rule 62-213.405, F.A.C. In such case, you must also check the following box:

- I hereby request that the department waive the processing time requirements of the air construction permit to accommodate the processing time frames of the Title V air operation permit.

Application Comment

Florida Gas Transmission Company is proposing to install a new 223 bhp gas-fired SI ICE 4-stroke rich-burn emergency generator engine.

These proposed modifications are part of FGT's Phase VIII Expansion project, aimed at increasing the supply capacity of FGT's network servicing domestic, commercial, and industrial customers in Florida.

APPLICATION INFORMATION

Scope of Application

Emissions Unit ID Number	Description of Emissions Unit	Air Permit Type	Air Permit Processing Fee
	Emergency Generator Engine, GEN04, 223 bhp, 4-stroke, rich-burn natural gas fired	AC1D	\$0

Application Processing Fee

Check one: Attached - Amount: \$ _____

Not Applicable

APPLICATION INFORMATION

Owner/Authorized Representative Statement

Complete if applying for an air construction permit or an initial FESOP.

1. Owner/Authorized Representative Name : David Shellhouse, Vice President, Southeastern Operations
2. Owner/Authorized Representative Mailing Address Organization/Firm: Florida Gas Transmission Company, LLC Street Address: 2405 Lucien Way, Suite 200 City: Maitland State: FL Zip Code: 32751
3. Owner/Authorized Representative Telephone Numbers... Telephone: (407) 838 - 7122 ext. Fax: (407) 838 - 7151
4. Owner/Authorized Representative E-mail Address: <u>dave.shellhouse@SUG.com</u>
5. Owner/Authorized Representative Statement: <i>I, the undersigned, am the owner or authorized representative of the corporation, partnership, or other legal entity submitting this air permit application. To the best of my knowledge, the statements made in this application are true, accurate and complete, and any estimates of emissions reported in this application are based upon reasonable techniques for calculating emissions. I understand that a permit, if granted by the department, cannot be transferred without authorization from the department.</i> Signature <u><i>David Shellhouse</i></u> on behalf of David Shellhouse Date <u>11-25-08</u>

APPLICATION INFORMATION

Application Responsible Official Certification

Complete if applying for an initial, revised, or renewal Title V air operation permit or concurrent processing of an air construction permit and revised or renewal Title V air operation permit. If there are multiple responsible officials, the "application responsible official" need not be the "primary responsible official."

1. Application Responsible Official Name: NA			
2. Application Responsible Official Qualification (Check one or more of the following options, as applicable):			
<input type="checkbox"/> For a corporation, the president, secretary, treasurer, or vice-president of the corporation in charge of a principal business function, or any other person who performs similar policy or decision-making functions for the corporation, or a duly authorized representative of such person if the representative is responsible for the overall operation of one or more manufacturing, production, or operating facilities applying for or subject to a permit under Chapter 62-213, F.A.C.			
<input type="checkbox"/> For a partnership or sole proprietorship, a general partner or the proprietor, respectively.			
<input type="checkbox"/> For a municipality, county, state, federal, or other public agency, either a principal executive officer or ranking elected official.			
<input type="checkbox"/> The designated representative at an Acid Rain source, CAIR source, or Hg Budget source.			
3. Application Responsible Official Mailing Address...			
Organization/Firm:			
Street Address:			
City:	State:	Zip Code:	
4. Application Responsible Official Telephone Numbers...			
Telephone: () - ext. Fax: () -			
5. Application Responsible Official E-mail Address:			
6. Application Responsible Official Certification:			
<i>I, the undersigned, am a responsible official of the Title V source addressed in this air permit application. I hereby certify, based on information and belief formed after reasonable inquiry, that the statements made in this application are true, accurate and complete and that, to the best of my knowledge, any estimates of emissions reported in this application are based upon reasonable techniques for calculating emissions. The air pollutant emissions units and air pollution control equipment described in this application will be operated and maintained so as to comply with all applicable standards for control of air pollutant emissions found in the statutes of the State of Florida and rules of the Department of Environmental Protection and revisions thereof and all other applicable requirements identified in this application to which the Title V source is subject. I understand that a permit, if granted by the department, cannot be transferred without authorization from the department, and I will promptly notify the department upon sale or legal transfer of the facility or any permitted emissions unit. Finally, I certify that the facility and each emissions unit are in compliance with all applicable requirements to which they are subject, except as identified in compliance plan(s) submitted with this application.</i>			
_____ Signature		_____ Date	

APPLICATION INFORMATION

Professional Engineer Certification

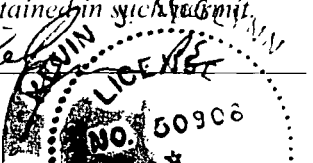
1. Professional Engineer Name: Kevin J. McGlynn Registration Number: 50908
2. Professional Engineer Mailing Address. Organization/Firm: Trow Engineering consultants, Inc. Street Address: 1200 Metropolitan Blvd. Ste. 200 City: Tallahassee State: FL Zip Code: 32308
3. Professional Engineer Telephone Numbers. Telephone: (850) 385 - 5441 ext. 314 Fax: (850) 385 - 5523
4. Professional Engineer E-mail Address: <u>Kevin.mcglynn@trow.com</u>
5. Professional Engineer Statement: <i>I, the undersigned, hereby certify, except as particularly noted herein*, that:</i> <i>(1) To the best of my knowledge, there is reasonable assurance that the air pollutant emissions unit(s) and the air pollution control equipment described in this application for air permit, when properly operated and maintained, will comply with all applicable standards for control of air pollutant emissions found in the Florida Statutes and rules of the Department of Environmental Protection; and</i> <i>(2) To the best of my knowledge, any emission estimates reported or relied on in this application are true, accurate, and complete and are either based upon reasonable techniques available for calculating emissions or, for emission estimates of hazardous air pollutants not regulated for an emissions unit addressed in this application, based solely upon the materials, information and calculations submitted with this application.</i> <i>(3) If the purpose of this application is to obtain a Title V air operation permit (check here <input type="checkbox"/> , if so), I further certify that each emissions unit described in this application for air permit, when properly operated and maintained, will comply with the applicable requirements identified in this application to which the unit is subject, except those emissions units for which a compliance plan and schedule is submitted with this application.</i> <i>(4) If the purpose of this application is to obtain an air construction permit (check here <input checked="" type="checkbox"/> , if so) or concurrently process and obtain an air construction permit and a Title V air operation permit revision or renewal for one or more proposed new or modified emissions units (check here <input type="checkbox"/> , if so), I further certify that the engineering features of each such emissions unit described in this application have been designed or examined by me or individuals under my direct supervision and found to be in conformity with sound engineering principles applicable to the control of emissions of the air pollutants characterized in this application.</i> <i>(5) If the purpose of this application is to obtain an initial air operation permit or operation permit revision or renewal for one or more newly constructed or modified emissions units (check here <input type="checkbox"/> . if so), I further certify that, with the exception of any changes detailed as part of this application, each such emissions unit has been constructed or modified in substantial accordance with the information given in the corresponding application for air construction permit and with all provisions contained in such permit.</i> Signature <u>Kevin J. McGlynn</u> Date <u>Nov. 18, 2008</u> (seal) 

* Attach any exception to certification statement

II. FACILITY INFORMATION
A. GENERAL FACILITY INFORMATION

Facility Location and Type

1. Facility UTM Coordinates... Zone 17 East (km) 249.02 North (km) 3339.60		2. Facility Latitude/Longitude... Latitude (DD/MM/SS) 30/09/54 Longitude (DD/MM/SS) 83/36/33	
3. Governmental Facility Code: 0	4. Facility Status Code: A	5. Facility Major Group SIC Code: 49	6. Facility SIC(s): 4922
7. Facility Comment :			
Compressor Station No. 15 is an existing natural gas pipeline compressor station with six reciprocating compressor engines and two compressor turbines.			

Facility Contact

1. Facility Contact Name: David Read
2. Facility Contact Mailing Address: Organization/Firm: Florida Gas Transmission Company Street Address: Rt. 5, Box 48610 CR. 361 or Pisgah Rd City: Perry State: FL Zip Code: 32347
3. Facility Contact Telephone Numbers: Telephone: (850) 350 - 5367 ext. Fax: (850) 350 - 5351
4. Facility Contact E-mail Address: David.Read@SUG.com

Facility Primary Responsible Official

Complete if an "application responsible official" is identified in Section I that is not the facility "primary responsible official."

1. Facility Primary Responsible Official Name: NA
2. Facility Primary Responsible Official Mailing Address... Organization/Firm: Street Address: City: State: Zip Code:
3. Facility Primary Responsible Official Telephone Numbers... Telephone: () - ext. Fax: () -
4. Facility Primary Responsible Official E-mail Address:

FACILITY INFORMATION

Facility Regulatory Classifications

Check all that would apply *following* completion of all projects and implementation of all other changes proposed in this application for air permit. Refer to instructions to distinguish between a "major source" and a "synthetic minor source."

1.	<input type="checkbox"/> Small Business Stationary Source	<input type="checkbox"/> Unknown
2.	<input type="checkbox"/> Synthetic Non-Title V Source	
3.	<input checked="" type="checkbox"/> Title V Source	
4.	<input checked="" type="checkbox"/> Major Source of Air Pollutants, Other than Hazardous Air Pollutants (HAPs)	
5.	<input type="checkbox"/> Synthetic Minor Source of Air Pollutants, Other than HAPs	
6.	<input checked="" type="checkbox"/> Major Source of Hazardous Air Pollutants (HAPs)	
7.	<input type="checkbox"/> Synthetic Minor Source of HAPs	
8.	<input checked="" type="checkbox"/> One or More Emissions Units Subject to NSPS (40 CFR Part 60)	
9.	<input type="checkbox"/> One or More Emissions Units Subject to Emission Guidelines (40 CFR Part 60)	
10.	<input checked="" type="checkbox"/> One or More Emissions Units Subject to NESHAP (40 CFR Part 61 or Part 63)	
11.	<input type="checkbox"/> Title V Source Solely by EPA Designation (40 CFR 70.3(a)(5))	
12.	Facility Regulatory Classifications Comment: New gas-fired reciprocating internal combustion emergency generator engine is subject to (NSPS) 40 CFR 60 Subpart JJJJ and (NESHAP) 40 CFR 63 Subpart ZZZZ.	

FACILITY INFORMATION

List of Pollutants Emitted by Facility

1. Pollutant Emitted	2. Pollutant Classification	3. Emissions Cap [Y or N]?
NOX	A	N
CO	A	N
VOC	B	N
SO2	B	N
PM	B	N
HAPs	A	N

FACILITY INFORMATION

B. EMISSIONS CAPS

Facility-Wide or Multi-Unit Emissions Caps

1. Pollutant Subject to Emissions Cap	2. Facility-Wide Cap [Y or N]? (all units)	3. Emissions Unit ID's Under Cap (if not all units)	4. Hourly Cap (lb/hr)	5. Annual Cap (ton/yr)	6. Basis for Emissions Cap
NA					

7. Facility-Wide or Multi-Unit Emissions Cap Comment:

FACILITY INFORMATION

C. FACILITY ADDITIONAL INFORMATION

Additional Requirements for All Applications, Except as Otherwise Stated

1. Facility Plot Plan: (Required for all permit applications, except Title V air operation permit revision applications if this information was submitted to the department within the previous five years and would not be altered as a result of the revision being sought) <input checked="" type="checkbox"/> Attached, Document ID: <u>Attach. D</u> <input type="checkbox"/> Previously Submitted, Date: _____
2. Process Flow Diagram(s): (Required for all permit applications, except Title V air operation permit revision applications if this information was submitted to the department within the previous five years and would not be altered as a result of the revision being sought) <input checked="" type="checkbox"/> Attached, Document ID: <u>Attach. B</u> <input type="checkbox"/> Previously Submitted, Date: _____
3. Precautions to Prevent Emissions of Unconfined Particulate Matter: (Required for all permit applications, except Title V air operation permit revision applications if this information was submitted to the department within the previous five years and would not be altered as a result of the revision being sought) <input type="checkbox"/> Attached, Document ID: <u>Attach. C</u> <input checked="" type="checkbox"/> Previously Submitted, Date: _____

Additional Requirements for Air Construction Permit Applications

1. Area Map Showing Facility Location: <input checked="" type="checkbox"/> Attached, Document ID: <u>Narr.Fig. 1-1</u> <input type="checkbox"/> Not Applicable (existing permitted facility)
2. Description of Proposed Construction, Modification, or Plantwide Applicability Limit (PAL): <input checked="" type="checkbox"/> Attached, Document ID: <u>Narr.Sect 2.0</u>
3. Rule Applicability Analysis: <input checked="" type="checkbox"/> Attached, Document ID: <u>Narr.Sect 3.0</u>
4. List of Exempt Emissions Units: <input checked="" type="checkbox"/> Attached, Document ID: <u>Attach. H</u> <input type="checkbox"/> Not Applicable (no exempt units at facility)
5. Fugitive Emissions Identification: <input checked="" type="checkbox"/> Attached, Document ID: <u>Narr.Sect 2.2.5</u> <input type="checkbox"/> Not Applicable
6. Air Quality Analysis (Rule 62-212.400(7), F.A.C.): <input type="checkbox"/> Attached, Document ID: _____ <input checked="" type="checkbox"/> Not Applicable
7. Source Impact Analysis (Rule 62-212.400(5), F.A.C.): <input type="checkbox"/> Attached, Document ID: _____ <input checked="" type="checkbox"/> Not Applicable
8. Air Quality Impact since 1977 (Rule 62-212.400(4)(e), F.A.C.): <input type="checkbox"/> Attached, Document ID: _____ <input checked="" type="checkbox"/> Not Applicable
9. Additional Impact Analyses (Rules 62-212.400(8) and 62-212.500(4)(e), F.A.C.): <input type="checkbox"/> Attached, Document ID: _____ <input checked="" type="checkbox"/> Not Applicable
10. Alternative Analysis Requirement (Rule 62-212.500(4)(g), F.A.C.): <input type="checkbox"/> Attached, Document ID: _____ <input checked="" type="checkbox"/> Not Applicable

FACILITY INFORMATION

C. FACILITY ADDITIONAL INFORMATION (CONTINUED)

Additional Requirements for FESOP Applications

- | |
|---|
| 1. List of Exempt Emissions Units:
<input type="checkbox"/> Attached, Document ID: <u>NA</u> <input type="checkbox"/> Not Applicable (no exempt units at facility) |
|---|

Additional Requirements for Title V Air Operation Permit Applications

- | |
|--|
| 1. List of Insignificant Activities: (Required for initial/renewal applications only)
<input type="checkbox"/> Attached, Document ID: <u>NA</u> <input type="checkbox"/> Not Applicable (revision application) |
| 2. Identification of Applicable Requirements: (Required for initial/renewal applications, and for revision applications if this information would be changed as a result of the revision being sought)
<input type="checkbox"/> Attached, Document ID: <u>NA</u>
<input type="checkbox"/> Not Applicable (revision application with no change in applicable requirements) |
| 3. Compliance Report and Plan: (Required for all initial/revision/renewal applications)
<input type="checkbox"/> Attached, Document ID: <u>NA</u>

Note: A compliance plan must be submitted for each emissions unit that is not in compliance with all applicable requirements at the time of application and/or at any time during application processing. The department must be notified of any changes in compliance status during application processing. |
| 4. List of Equipment/Activities Regulated under Title VI: (If applicable, required for initial/renewal applications only)
<input type="checkbox"/> Attached, Document ID: <u>NA</u>
<input type="checkbox"/> Equipment/Activities Onsite but Not Required to be Individually Listed
<input type="checkbox"/> Not Applicable |
| 5. Verification of Risk Management Plan Submission to EPA: (If applicable, required for initial/renewal applications only)
<input type="checkbox"/> Attached, Document ID: <u>NA</u> <input type="checkbox"/> Not Applicable |
| 6. Requested Changes to Current Title V Air Operation Permit:
<input type="checkbox"/> Attached, Document ID: <u>NA</u> <input type="checkbox"/> Not Applicable |

FACILITY INFORMATION

C. FACILITY ADDITIONAL INFORMATION (CONTINUED)

Additional Requirements for Facilities Subject to Acid Rain, CAIR, or Hg Budget Program

1. Acid Rain Program Forms: NA Acid Rain Part Application (DEP Form No. 62-210.900(1)(a)): <input type="checkbox"/> Attached, Document ID: _____ <input type="checkbox"/> Previously Submitted, Date: _____ <input type="checkbox"/> Not Applicable (not an Acid Rain source) Phase II NO _x Averaging Plan (DEP Form No. 62-210.900(1)(a)1.): <input type="checkbox"/> Attached, Document ID: _____ <input type="checkbox"/> Previously Submitted, Date: _____ <input type="checkbox"/> Not Applicable New Unit Exemption (DEP Form No. 62-210.900(1)(a)2.): <input type="checkbox"/> Attached, Document ID: _____ <input type="checkbox"/> Previously Submitted, Date: _____ <input type="checkbox"/> Not Applicable
2. CAIR Part (DEP Form No. 62-210.900(1)(b)): NA <input type="checkbox"/> Attached, Document ID: _____ <input type="checkbox"/> Previously Submitted, Date: _____ <input type="checkbox"/> Not Applicable (not a CAIR source)
3. Hg Budget Part (DEP Form No. 62-210.900(1)(c)): NA <input type="checkbox"/> Attached, Document ID: _____ <input type="checkbox"/> Previously Submitted, Date: _____ <input type="checkbox"/> Not Applicable (not a Hg Budget unit)

Additional Requirements Comment

Attachment B provides a Process Flow Diagram
Attachment C presents Precautions to Prevent Emissions of Unconfined Particulate Matter
Attachment D contains a plot plan.
Attachment E has vendor supplied information.
Attachment F has supporting calculations.
Attachment G contains a recent fuel analysis
Attachment H contains a list of Exempt Emission Units

EMISSIONS UNIT INFORMATION

Section [1] of [1]

A. GENERAL EMISSIONS UNIT INFORMATION

Title V Air Operation Permit Emissions Unit Classification

1. Regulated or Unregulated Emissions Unit? (Check one, if applying for an initial, revised or renewal Title V air operation permit. Skip this item if applying for an air construction permit or FESOP only.) NA

The emissions unit addressed in this Emissions Unit Information Section is a regulated emissions unit.

The emissions unit addressed in this Emissions Unit Information Section is an unregulated emissions unit.

Emissions Unit Description and Status

1. Type of Emissions Unit Addressed in this Section: (Check one)

This Emissions Unit Information Section addresses, as a single emissions unit, a single process or production unit, or activity, which produces one or more air pollutants and which has at least one definable emission point (stack or vent).

This Emissions Unit Information Section addresses, as a single emissions unit, a group of process or production units and activities which has at least one definable emission point (stack or vent) but may also produce fugitive emissions.

This Emissions Unit Information Section addresses, as a single emissions unit, one or more process or production units and activities which produce fugitive emissions only.

2. Description of Emissions Unit Addressed in this Section:

223 bhp natural gas fired, spark ignition, 4-stroke, rich-burn, internal combustion emergency generator engine, FGT Engine No. GEN04

3. Emissions Unit Identification Number: 013

4. Emissions Unit Status Code: C	5. Commence Construction Date: NA	6. Initial Startup Date: NA	7. Emissions Unit Major Group SIC Code: 49
---	--	------------------------------------	---

8. Federal Program Applicability: (Check all that apply)

Acid Rain Unit

CAIR Unit

Hg Budget Unit

9. Package Unit:
Manufacturer: Generac
Model Number: SG150

10. Generator Nameplate Rating: 150 KW

11. Emissions Unit Comment:

Fuel will be exclusively natural gas from the FGT's gas pipeline

EMISSIONS UNIT INFORMATION

Section [1] of [1]

Emissions Unit Control Equipment/Method: Control NA of

1. Control Equipment/Method Description:

2. Control Device or Method Code:

Emissions Unit Control Equipment/Method: Control of

1. Control Equipment/Method Description:

2. Control Device or Method Code:

Emissions Unit Control Equipment/Method: Control of

1. Control Equipment/Method Description:

2. Control Device or Method Code:

Emissions Unit Control Equipment/Method: Control of

1. Control Equipment/Method Description:

2. Control Device or Method Code:

EMISSIONS UNIT INFORMATION

Section [1] of [1]

B. EMISSIONS UNIT CAPACITY INFORMATION

(Optional for unregulated emissions units.)

Emissions Unit Operating Capacity and Schedule

1. Maximum Process or Throughput Rate: NA
2. Maximum Production Rate: NA
3. Maximum Heat Input Rate: 2.49 million Btu/hr
4. Maximum Incineration Rate: pounds/hr NA tons/day
5. Requested Maximum Operating Schedule: hours/day days/week weeks/year 100 hours/year
6. Operating Capacity/Schedule Comment: Schedule is based on USEPA defined emergency generator usage of 100 hours per year for maintenance and testing (40 CFR 60.4243(d)). This does not include emergency operation.

EMISSIONS UNIT INFORMATION

Section [1] of [1]

C. EMISSION POINT (STACK/VENT) INFORMATION**(Optional for unregulated emissions units.)****Emission Point Description and Type**

1. Identification of Point on Plot Plan or Flow Diagram: GEN04		2. Emission Point Type Code: 1			
3. Descriptions of Emission Points Comprising this Emissions Unit for VE Tracking: NA					
4. ID Numbers or Descriptions of Emission Units with this Emission Point in Common: NA					
5. Discharge Type Code: V		6. Stack Height: 7.0 Feet		7. Exit Diameter: 0.33 feet	
8. Exit Temperature: 1490 °F		9. Actual Volumetric Flow Rate: 4335 acfm		10. Water Vapor: NA %	
11. Maximum Dry Standard Flow Rate: NA dscfm			12. Nonstack Emission Point Height: NA feet		
13. Emission Point UTM Coordinates... Zone: 17 East (km): 249.02 North (km): 3339.60			14. Emission Point Latitude/Longitude... Latitude (DD/MM/SS) Longitude (DD/MM/SS)		
15. Emission Point Comment:					

EMISSIONS UNIT INFORMATION

Section [1] of [1]

D. SEGMENT (PROCESS/FUEL) INFORMATION

Segment Description and Rate: Segment 1 of 1

1. Segment Description (Process/Fuel Type): Natural gas fired 4-stroke, rich-burn engine driving an emergency generator.		
2. Source Classification Code (SCC): 2-02-002-53		3. SCC Units: million cubic feet burned
4. Maximum Hourly Rate: 0.0024	5. Maximum Annual Rate: 0.24	6. Estimated Annual Activity Factor: NA
7. Maximum % Sulfur: NA	8. Maximum % Ash: NA	9. Million Btu per SCC Unit: 1040
10. Segment Comment: Annual usage based on 100 hours per year operation.		

Segment Description and Rate: Segment __ of __

1. Segment Description (Process/Fuel Type): 		
2. Source Classification Code (SCC):		3. SCC Units:
4. Maximum Hourly Rate:	5. Maximum Annual Rate:	6. Estimated Annual Activity Factor:
7. Maximum % Sulfur:	8. Maximum % Ash:	9. Million Btu per SCC Unit:
10. Segment Comment:		

EMISSIONS UNIT INFORMATION

Section [1] of [1]

E. EMISSIONS UNIT POLLUTANTS

List of Pollutants Emitted by Emissions Unit

1. Pollutant Emitted	2. Primary Control Device Code	3. Secondary Control Device Code	4. Pollutant Regulatory Code
VOC			EL
SO ₂			NS
PM			NS
NO _x			EL
CO			EL
PM ₁₀			NS
HAPs			NS

EMISSIONS UNIT INFORMATION

Section [1] of [1]

POLLUTANT DETAIL INFORMATION

Page [1] of [6]

**F1. EMISSIONS UNIT POLLUTANT DETAIL INFORMATION –
POTENTIAL, FUGITIVE, AND ACTUAL EMISSIONS
(Optional for unregulated emissions units.)**

Complete a Subsection F1 for each pollutant identified in Subsection E if applying for an air construction permit or concurrent processing of an air construction permit and a revised or renewal Title V operation permit. Complete for each emissions-limited pollutant identified in Subsection E if applying for an air operation permit.

Potential, Estimated Fugitive, and Baseline & Projected Actual Emissions

1. Pollutant Emitted: NOX		2. Total Percent Efficiency of Control: unknown	
3. Potential Emissions: 0.98 lb/hour 0.05 tons/year		4. Synthetically Limited? <input type="checkbox"/> Yes <input checked="" type="checkbox"/> No	
5. Range of Estimated Fugitive Emissions (as applicable): NA to tons/year			
6. Emission Factor: 2.00 g/hp-hr Reference: Vendor data		7. Emissions Method Code: 5	
8.a. Baseline Actual Emissions (if required): NA tons/year		8.b. Baseline 24-month Period: From: To:	
9.a. Projected Actual Emissions (if required): NA tons/year		9.b. Projected Monitoring Period: <input type="checkbox"/> 5 years <input type="checkbox"/> 10 years	
10. Calculation of Emissions: (2.0 g/hp-hr)(223 bhp)(1lb/453.6 g) = 0.98 lb/hr (0.98 lb/hr)(100 hr/yr)(1 ton/2000 lb) = 0.05 ton/yr			
11. Potential, Fugitive, and Actual Emissions Comment: Calculations based on emergency generator usage of 100 hours per year and minimum control efficiency.			

EMISSIONS UNIT INFORMATION

Section [1] of [1]

POLLUTANT DETAIL INFORMATION

Page [1] of [6]

**F2. EMISSIONS UNIT POLLUTANT DETAIL INFORMATION -
ALLOWABLE EMISSIONS****Complete Subsection F2 if the pollutant identified in Subsection F1 is or would be subject to a numerical emissions limitation.**Allowable Emissions Allowable Emissions 1 of 1

1. Basis for Allowable Emissions Code: RULE	2. Future Effective Date of Allowable Emissions: NA
3. Allowable Emissions and Units: 2.0 g/hp-hr.	4. Equivalent Allowable Emissions: 0.98 lb/hour 0.05 tons/year
5. Method of Compliance: Monitor hours of operation	
6. Allowable Emissions Comment (Description of Operating Method): 60.4230 Table 1 limits NOX emissions to 2 g/hp-hr.	

Allowable Emissions Allowable Emissions of

1. Basis for Allowable Emissions Code:	2. Future Effective Date of Allowable Emissions:
3. Allowable Emissions and Units:	4. Equivalent Allowable Emissions: lb/hour tons/year
5. Method of Compliance:	
6. Allowable Emissions Comment (Description of Operating Method):	

Allowable Emissions Allowable Emissions of

1. Basis for Allowable Emissions Code:	2. Future Effective Date of Allowable Emissions:
3. Allowable Emissions and Units:	4. Equivalent Allowable Emissions: lb/hour tons/year
5. Method of Compliance:	
6. Allowable Emissions Comment (Description of Operating Method):	

EMISSIONS UNIT INFORMATION

Section [1] of [1]

POLLUTANT DETAIL INFORMATION

Page [2] of [6]

**F1. EMISSIONS UNIT POLLUTANT DETAIL INFORMATION –
POTENTIAL, FUGITIVE, AND ACTUAL EMISSIONS
(Optional for unregulated emissions units.)**

Complete a Subsection F1 for each pollutant identified in Subsection E if applying for an air construction permit or concurrent processing of an air construction permit and a revised or renewal Title V operation permit. Complete for each emissions-limited pollutant identified in Subsection E if applying for an air operation permit.

Potential, Estimated Fugitive, and Baseline & Projected Actual Emissions

1. Pollutant Emitted: CO		2. Total Percent Efficiency of Control: unknown	
3. Potential Emissions: 1.97 lb/hour 0.10 tons/year		4. Synthetically Limited? <input checked="" type="checkbox"/> Yes <input type="checkbox"/> No	
5. Range of Estimated Fugitive Emissions (as applicable): NA to tons/year			
6. Emission Factor: 4.0 g/hp-hr Reference: Vendor data		7. Emissions Method Code: 5	
8.a. Baseline Actual Emissions (if required): NA tons/year		8.b. Baseline 24-month Period: From: To:	
9.a. Projected Actual Emissions (if required): NA tons/year		9.b. Projected Monitoring Period: <input type="checkbox"/> 5 years <input type="checkbox"/> 10 years	
10. Calculation of Emissions: $(4.0 \text{ g/hp-hr})(223 \text{ bhp})(1\text{lb}/453.6 \text{ g}) = 1.97 \text{ lb/hr}$ $(1.97 \text{ lb/hr})(100 \text{ hr/yr})(1 \text{ ton}/2000 \text{ lb}) = 0.10 \text{ ton/yr}$			
11. Potential, Fugitive, and Actual Emissions Comment: Calculations based on emergency generator usage of 100 hours per year and minimum control efficiency.			

EMISSIONS UNIT INFORMATION

Section [1] of [1]

POLLUTANT DETAIL INFORMATION

Page [2] of [6]

**F2. EMISSIONS UNIT POLLUTANT DETAIL INFORMATION -
ALLOWABLE EMISSIONS****Complete Subsection F2 if the pollutant identified in Subsection F1 is or would be subject to a numerical emissions limitation.**Allowable Emissions Allowable Emissions 1 of 1

1. Basis for Allowable Emissions Code: RULE	2. Future Effective Date of Allowable Emissions: NA
3. Allowable Emissions and Units: 4.0 g/hp-hr.	4. Equivalent Allowable Emissions: 1.97 lb/hour 0.10 tons/year
5. Method of Compliance: Monitor hours of operation	
6. Allowable Emissions Comment (Description of Operating Method): 60.4230 Table 1 limits CO emissions to 4 g/hh-hr.	

Allowable Emissions Allowable Emissions of

1. Basis for Allowable Emissions Code:	2. Future Effective Date of Allowable Emissions:
3. Allowable Emissions and Units:	4. Equivalent Allowable Emissions: lb/hour tons/year
5. Method of Compliance:	
6. Allowable Emissions Comment (Description of Operating Method):	

Allowable Emissions Allowable Emissions of

1. Basis for Allowable Emissions Code:	2. Future Effective Date of Allowable Emissions:
3. Allowable Emissions and Units:	4. Equivalent Allowable Emissions: lb/hour tons/year
5. Method of Compliance:	
6. Allowable Emissions Comment (Description of Operating Method):	

EMISSIONS UNIT INFORMATION

Section [1] of [1]

POLLUTANT DETAIL INFORMATION

Page [3] of [6]

**F1. EMISSIONS UNIT POLLUTANT DETAIL INFORMATION –
POTENTIAL, FUGITIVE, AND ACTUAL EMISSIONS
(Optional for unregulated emissions units.)**

Complete a Subsection F1 for each pollutant identified in Subsection E if applying for an air construction permit or concurrent processing of an air construction permit and a revised or renewal Title V operation permit. Complete for each emissions-limited pollutant identified in Subsection E if applying for an air operation permit.

Potential, Estimated Fugitive, and Baseline & Projected Actual Emissions

1. Pollutant Emitted: VOC		2. Total Percent Efficiency of Control: unknown	
3. Potential Emissions: 0.49 lb/hour 0.025 tons/year		4. Synthetically Limited? <input type="checkbox"/> Yes <input checked="" type="checkbox"/> No	
5. Range of Estimated Fugitive Emissions (as applicable): NA to tons/year			
6. Emission Factor: 1.0 g/hp-hr Reference: Vendor data		7. Emissions Method Code: 5	
8.a. Baseline Actual Emissions (if required): NA tons/year		8.b. Baseline 24-month Period: From: To:	
9.a. Projected Actual Emissions (if required): NA tons/year		9.b. Projected Monitoring Period: <input type="checkbox"/> 5 years <input type="checkbox"/> 10 years	
10. Calculation of Emissions: $(1.0 \text{ g/hp-hr})(223 \text{ bhp})(1 \text{ lb}/453.6 \text{ g}) = 0.49 \text{ lb/hr}$ $(0.49 \text{ lb/hr})(100 \text{ hr/yr})(1 \text{ ton}/2000 \text{ lb}) = 0.025 \text{ ton/yr}$			
11. Potential, Fugitive, and Actual Emissions Comment: Calculations based on emergency generator usage of 100 hours per year and minimum control efficiency.			

EMISSIONS UNIT INFORMATION

Section [1] of [1]

POLLUTANT DETAIL INFORMATION

Page [3] of [6]

F2. EMISSIONS UNIT POLLUTANT DETAIL INFORMATION - ALLOWABLE EMISSIONS

Complete Subsection F2 if the pollutant identified in Subsection F1 is or would be subject to a numerical emissions limitation.

Allowable Emissions Allowable Emissions 1 of 1

1. Basis for Allowable Emissions Code: RULE	2. Future Effective Date of Allowable Emissions: NA
3. Allowable Emissions and Units: 1.0 g/hp-hr.	4. Equivalent Allowable Emissions: 0.49 lb/hour 0.025 tons/year
5. Method of Compliance: Monitor hours of operation	
6. Allowable Emissions Comment (Description of Operating Method): 60.4230 Table 1 limits VOC emissions to 1 g/hp-hr.	

Allowable Emissions Allowable Emissions of

1. Basis for Allowable Emissions Code:	2. Future Effective Date of Allowable Emissions:
3. Allowable Emissions and Units:	4. Equivalent Allowable Emissions: lb/hour tons/year
5. Method of Compliance:	
6. Allowable Emissions Comment (Description of Operating Method):	

Allowable Emissions Allowable Emissions of

1. Basis for Allowable Emissions Code:	2. Future Effective Date of Allowable Emissions:
3. Allowable Emissions and Units:	4. Equivalent Allowable Emissions: lb/hour tons/year
5. Method of Compliance:	
6. Allowable Emissions Comment (Description of Operating Method):	

EMISSIONS UNIT INFORMATION

Section [1] of [1]

POLLUTANT DETAIL INFORMATION

Page [4] of [6]

**F1. EMISSIONS UNIT POLLUTANT DETAIL INFORMATION –
POTENTIAL, FUGITIVE, AND ACTUAL EMISSIONS
(Optional for unregulated emissions units.)**

Complete a Subsection F1 for each pollutant identified in Subsection E if applying for an air construction permit or concurrent processing of an air construction permit and a revised or renewal Title V operation permit. Complete for each emissions-limited pollutant identified in Subsection E if applying for an air operation permit.

Potential, Estimated Fugitive, and Baseline & Projected Actual Emissions

1. Pollutant Emitted: SO2		2. Total Percent Efficiency of Control:	
3. Potential Emissions: 0.117 lb/hour 0.006 tons/year		4. Synthetically Limited? <input checked="" type="checkbox"/> Yes <input type="checkbox"/> No	
5. Range of Estimated Fugitive Emissions (as applicable): NA to tons/year			
6. Emission Factor: 10 grains / 100 scf Reference: FERC limit		7. Emissions Method Code: 2	
8.a. Baseline Actual Emissions (if required): NA tons/year		8.b. Baseline 24-month Period: From: To:	
9.a. Projected Actual Emissions (if required): NA tons/year		9.b. Projected Monitoring Period: <input type="checkbox"/> 5 years <input type="checkbox"/> 10 years	
10. Calculation of Emissions: $(10 \text{ gr S}/100 \text{ scf})(2395 \text{ scf/hr})(1 \text{ lb}/7000 \text{ gr}) = 0.034 \text{ lb S/hr}$ $(0.034 \text{ lb S/hr})(2 \text{ lb SO}_2/\text{lb S}) = 0.068 \text{ lb SO}_2/\text{hr}$ $(0.068 \text{ lb SO}_2/\text{hr})(100 \text{ hr/yr})(1 \text{ ton}/2000 \text{ lb}) = 0.003 \text{ ton/yr}$			
11. Potential, Fugitive, and Actual Emissions Comment: Calculations based on emergency generator usage of 100 hours per year.			

**F2. EMISSIONS UNIT POLLUTANT DETAIL INFORMATION -
 ALLOWABLE EMISSIONS**

Complete Subsection F2 if the pollutant identified in Subsection F1 is or would be subject to a numerical emissions limitation.

Allowable Emissions Allowable Emissions NA of

1. Basis for Allowable Emissions Code:	2. Future Effective Date of Allowable Emissions: NA
3. Allowable Emissions and Units:	4. Equivalent Allowable Emissions: lb/hour tons/year
5. Method of Compliance:	
6. Allowable Emissions Comment (Description of Operating Method):	

Allowable Emissions Allowable Emissions of

1. Basis for Allowable Emissions Code:	2. Future Effective Date of Allowable Emissions:
3. Allowable Emissions and Units:	4. Equivalent Allowable Emissions: lb/hour tons/year
5. Method of Compliance:	
6. Allowable Emissions Comment (Description of Operating Method):	

Allowable Emissions Allowable Emissions of

1. Basis for Allowable Emissions Code:	2. Future Effective Date of Allowable Emissions:
3. Allowable Emissions and Units:	4. Equivalent Allowable Emissions: lb/hour tons/year
5. Method of Compliance:	
6. Allowable Emissions Comment (Description of Operating Method):	

EMISSIONS UNIT INFORMATION

Section [1] of [1]

POLLUTANT DETAIL INFORMATION

Page [5] of [6]

**F1. EMISSIONS UNIT POLLUTANT DETAIL INFORMATION –
POTENTIAL, FUGITIVE, AND ACTUAL EMISSIONS**

(Optional for unregulated emissions units.)

Complete a Subsection F1 for each pollutant identified in Subsection E if applying for an air construction permit or concurrent processing of an air construction permit and a revised or renewal Title V operation permit. Complete for each emissions-limited pollutant identified in Subsection E if applying for an air operation permit.

Potential, Estimated Fugitive, and Baseline & Projected Actual Emissions

1. Pollutant Emitted: PM		2. Total Percent Efficiency of Control:	
3. Potential Emissions: 0.05 lb/hour 0.002 tons/year		4. Synthetically Limited? <input checked="" type="checkbox"/> Yes <input type="checkbox"/> No	
5. Range of Estimated Fugitive Emissions (as applicable): NA to tons/year			
6. Emission Factor: 0.01941 lb/MM Btu Reference: Table 3.2-3, AP-42 7/00		7. Emissions Method Code: 3	
8.a. Baseline Actual Emissions (if required): NA tons/year		8.b. Baseline 24-month Period: From: To:	
9.a. Projected Actual Emissions (if required): NA tons/year		9.b. Projected Monitoring Period: <input type="checkbox"/> 5 years <input type="checkbox"/> 10 years	
10. Calculation of Emissions: (0.01941 lb/MM Btu)(2.49 MM Btu/hr) = 0.048 lb/hr (0.048 lb/hr)(100 hr/yr)(1 ton/2000 lb) = 0.002 ton/y			
11. Potential, Fugitive, and Actual Emissions Comment: Calculations based on emergency generator usage of 100 hours per year.			

**F2. EMISSIONS UNIT POLLUTANT DETAIL INFORMATION -
ALLOWABLE EMISSIONS**

Complete Subsection F2 if the pollutant identified in Subsection F1 is or would be subject to a numerical emissions limitation.

Allowable Emissions Allowable Emissions NA of

1. Basis for Allowable Emissions Code:	2. Future Effective Date of Allowable Emissions: NA
3. Allowable Emissions and Units:	4. Equivalent Allowable Emissions: lb/hour tons/year
5. Method of Compliance:	
6. Allowable Emissions Comment (Description of Operating Method):	

Allowable Emissions Allowable Emissions of

1. Basis for Allowable Emissions Code:	2. Future Effective Date of Allowable Emissions:
3. Allowable Emissions and Units:	4. Equivalent Allowable Emissions: lb/hour tons/year
5. Method of Compliance:	
6. Allowable Emissions Comment (Description of Operating Method):	

Allowable Emissions Allowable Emissions of

1. Basis for Allowable Emissions Code:	2. Future Effective Date of Allowable Emissions:
3. Allowable Emissions and Units:	4. Equivalent Allowable Emissions: lb/hour tons/year
5. Method of Compliance:	
6. Allowable Emissions Comment (Description of Operating Method):	

**F1. EMISSIONS UNIT POLLUTANT DETAIL INFORMATION –
POTENTIAL, FUGITIVE, AND ACTUAL EMISSIONS
(Optional for unregulated emissions units.)**

Complete a Subsection F1 for each pollutant identified in Subsection E if applying for an air construction permit or concurrent processing of an air construction permit and a revised or renewal Title V operation permit. Complete for each emissions-limited pollutant identified in Subsection E if applying for an air operation permit.

Potential, Estimated Fugitive, and Baseline & Projected Actual Emissions

1. Pollutant Emitted: HAPS		2. Total Percent Efficiency of Control:	
3. Potential Emissions: 0.058 lb/hour 0.003 tons/year		4. Synthetically Limited? <input checked="" type="checkbox"/> Yes <input type="checkbox"/> No	
5. Range of Estimated Fugitive Emissions (as applicable): NA to tons/year			
6. Emission Factor: 0.0234 lb/MM Btu Reference: AP-42, Table 3.2-3		7. Emissions Method Code: 3	
8.a. Baseline Actual Emissions (if required): NA tons/year		8.b. Baseline 24-month Period: From: To:	
9.a. Projected Actual Emissions (if required): NA tons/year		9.b. Projected Monitoring Period: <input type="checkbox"/> 5 years <input type="checkbox"/> 10 years	
10. Calculation of Emissions: $(0.0234 \text{ lb/MM Btu})(2.49 \text{ MM Btu/hr}) = 0.058 \text{ lb/hr}$ $(0.058 \text{ lb/hr})(100 \text{ hr/yr})(1 \text{ ton}/2000 \text{ lb}) = 0.003 \text{ ton/y}$			
11. Potential, Fugitive, and Actual Emissions Comment: Calculations based on emergency generator usage of 100 hours per year.			

EMISSIONS UNIT INFORMATION

Section [1] of [1]

POLLUTANT DETAIL INFORMATION

Page [6] of [6]

**F2. EMISSIONS UNIT POLLUTANT DETAIL INFORMATION -
ALLOWABLE EMISSIONS****Complete Subsection F2 if the pollutant identified in Subsection F1 is or would be subject to a numerical emissions limitation.****Allowable Emissions** Allowable Emissions NA of

1. Basis for Allowable Emissions Code:	2. Future Effective Date of Allowable Emissions: NA
3. Allowable Emissions and Units:	4. Equivalent Allowable Emissions: lb/hour tons/year
5. Method of Compliance:	
6. Allowable Emissions Comment (Description of Operating Method):	

Allowable Emissions Allowable Emissions __ of __

1. Basis for Allowable Emissions Code:	2. Future Effective Date of Allowable Emissions:
3. Allowable Emissions and Units:	4. Equivalent Allowable Emissions: lb/hour tons/year
5. Method of Compliance:	
6. Allowable Emissions Comment (Description of Operating Method):	

Allowable Emissions Allowable Emissions __ of __

1. Basis for Allowable Emissions Code:	2. Future Effective Date of Allowable Emissions:
3. Allowable Emissions and Units:	4. Equivalent Allowable Emissions: lb/hour tons/year
5. Method of Compliance:	
6. Allowable Emissions Comment (Description of Operating Method):	

EMISSIONS UNIT INFORMATION

Section [1] of [1]

G. VISIBLE EMISSIONS INFORMATION

Complete Subsection G if this emissions unit is or would be subject to a unit-specific visible emissions limitation.

Visible Emissions Limitation: Visible Emissions Limitation NA of

1. Visible Emissions Subtype:	2. Basis for Allowable Opacity: <input type="checkbox"/> Rule <input type="checkbox"/> Other
3. Allowable Opacity: Normal Conditions: % Exceptional Conditions: % Maximum Period of Excess Opacity Allowed: min/hour 5	
3. Method of Compliance:	
4. Visible Emissions Comment:	

Visible Emissions Limitation: Visible Emissions Limitation of

1. Visible Emissions Subtype:	2. Basis for Allowable Opacity: <input type="checkbox"/> Rule <input type="checkbox"/> Other
3. Allowable Opacity: Normal Conditions: % Exceptional Conditions: % Maximum Period of Excess Opacity Allowed: min/hour	
4. Method of Compliance:	
5. Visible Emissions Comment:	

EMISSIONS UNIT INFORMATION

Section [1] of [1]

H. CONTINUOUS MONITOR INFORMATION

Complete Subsection H if this emissions unit is or would be subject to continuous monitoring.

Continuous Monitoring System: Continuous Monitor NA of

1. Parameter Code:	2. Pollutant(s):
3. CMS Requirement:	<input type="checkbox"/> Rule <input type="checkbox"/> Other
4. Monitor Information... Manufacturer: Model Number: Serial Number:	
5. Installation Date:	6. Performance Specification Test Date:
7. Continuous Monitor Comment:	

Continuous Monitoring System: Continuous Monitor of

1. Parameter Code:	2. Pollutant(s):
3. CMS Requirement:	<input type="checkbox"/> Rule <input type="checkbox"/> Other
4. Monitor Information... Manufacturer: Model Number: Serial Number:	
5. Installation Date:	6. Performance Specification Test Date:
7. Continuous Monitor Comment:	

EMISSIONS UNIT INFORMATION

Section | 1 | of | 1 |

I. EMISSIONS UNIT ADDITIONAL INFORMATION

Additional Requirements for All Applications, Except as Otherwise Stated

1. Process Flow Diagram: (Required for all permit applications, except Title V air operation permit revision applications if this information was submitted to the department within the previous five years and would not be altered as a result of the revision being sought) <input checked="" type="checkbox"/> Attached, Document ID: <u>Attach. B</u> <input type="checkbox"/> Previously Submitted, Date _____
2. Fuel Analysis or Specification: (Required for all permit applications, except Title V air operation permit revision applications if this information was submitted to the department within the previous five years and would not be altered as a result of the revision being sought) <input checked="" type="checkbox"/> Attached, Document ID: <u>Attach. G</u> <input type="checkbox"/> Previously Submitted, Date _____
3. Detailed Description of Control Equipment: (Required for all permit applications, except Title V air operation permit revision applications if this information was submitted to the department within the previous five years and would not be altered as a result of the revision being sought) <input checked="" type="checkbox"/> Attached, Document ID: <u>See note below</u> <input type="checkbox"/> Previously Submitted, Date _____
4. Procedures for Startup and Shutdown: (Required for all operation permit applications, except Title V air operation permit revision applications if this information was submitted to the department within the previous five years and would not be altered as a result of the revision being sought) <input type="checkbox"/> Attached, Document ID: _____ <input type="checkbox"/> Previously Submitted, Date _____ <input checked="" type="checkbox"/> Not Applicable (construction application)
5. Operation and Maintenance Plan: (Required for all permit applications, except Title V air operation permit revision applications if this information was submitted to the department within the previous five years and would not be altered as a result of the revision being sought) <input type="checkbox"/> Attached, Document ID: _____ <input type="checkbox"/> Previously Submitted, Date _____ <input checked="" type="checkbox"/> Not Applicable
6. Compliance Demonstration Reports/Records: <input type="checkbox"/> Attached, Document ID: _____ Test Date(s)/Pollutant(s) Tested: _____ <input type="checkbox"/> Previously Submitted, Date: _____ Test Date(s)/Pollutant(s) Tested: _____ <input type="checkbox"/> To be Submitted, Date (if known): _____ Test Date(s)/Pollutant(s) Tested: _____ <input checked="" type="checkbox"/> Not Applicable Note: For FESOP applications, all required compliance demonstration records/reports must be submitted at the time of application. For Title V air operation permit applications, all required compliance demonstration reports/records must be submitted at the time of application, or a compliance plan must be submitted at the time of application.
7. Other Information Required by Rule or Statute: <input type="checkbox"/> Attached, Document ID: _____ <input checked="" type="checkbox"/> Not Applicable

EMISSIONS UNIT INFORMATION

Section [1] of [1]

I. EMISSIONS UNIT ADDITIONAL INFORMATION (CONTINUED)

Additional Requirements for Air Construction Permit Applications

1. Control Technology Review and Analysis (Rules 62-212.400(10) and 62-212.500(7), F.A.C.; 40 CFR 63.43(d) and (e)): <input checked="" type="checkbox"/> Attached, Document ID: <u>Narr. Sec. 3.0</u> <input type="checkbox"/> Not Applicable
2. Good Engineering Practice Stack Height Analysis (Rules 62-212.400(4)(d) and 62-212.500(4)(f), F.A.C.): <input type="checkbox"/> Attached, Document ID: _____ <input checked="" type="checkbox"/> Not Applicable
3. Description of Stack Sampling Facilities: (Required for proposed new stack sampling facilities only) <input type="checkbox"/> Attached, Document ID: _____ <input checked="" type="checkbox"/> Not Applicable

Additional Requirements for Title V Air Operation Permit Applications

1. Identification of Applicable Requirements: <input type="checkbox"/> Attached, Document ID: <u>NA</u>
2. Compliance Assurance Monitoring: <input type="checkbox"/> Attached, Document ID: _____ <input type="checkbox"/> Not Applicable
3. Alternative Methods of Operation: <input type="checkbox"/> Attached, Document ID: _____ <input type="checkbox"/> Not Applicable
4. Alternative Modes of Operation (Emissions Trading): <input type="checkbox"/> Attached, Document ID: _____ <input type="checkbox"/> Not Applicable

Additional Requirements Comment

Supplemental information is provided in the narrative description and Attachments B, and G accompanying these forms.

The manufacturer has not completed design specifications and has not provided final emission rates at this time. Emissions will comply with applicable 40 CFR Subpart JJJJ requirements.

Specifications for the sampling facilities have not been completed at this time. Final specifications will comply with USEPA and FDEP regulatory requirements.

Attachment B
Process Flow Diagram

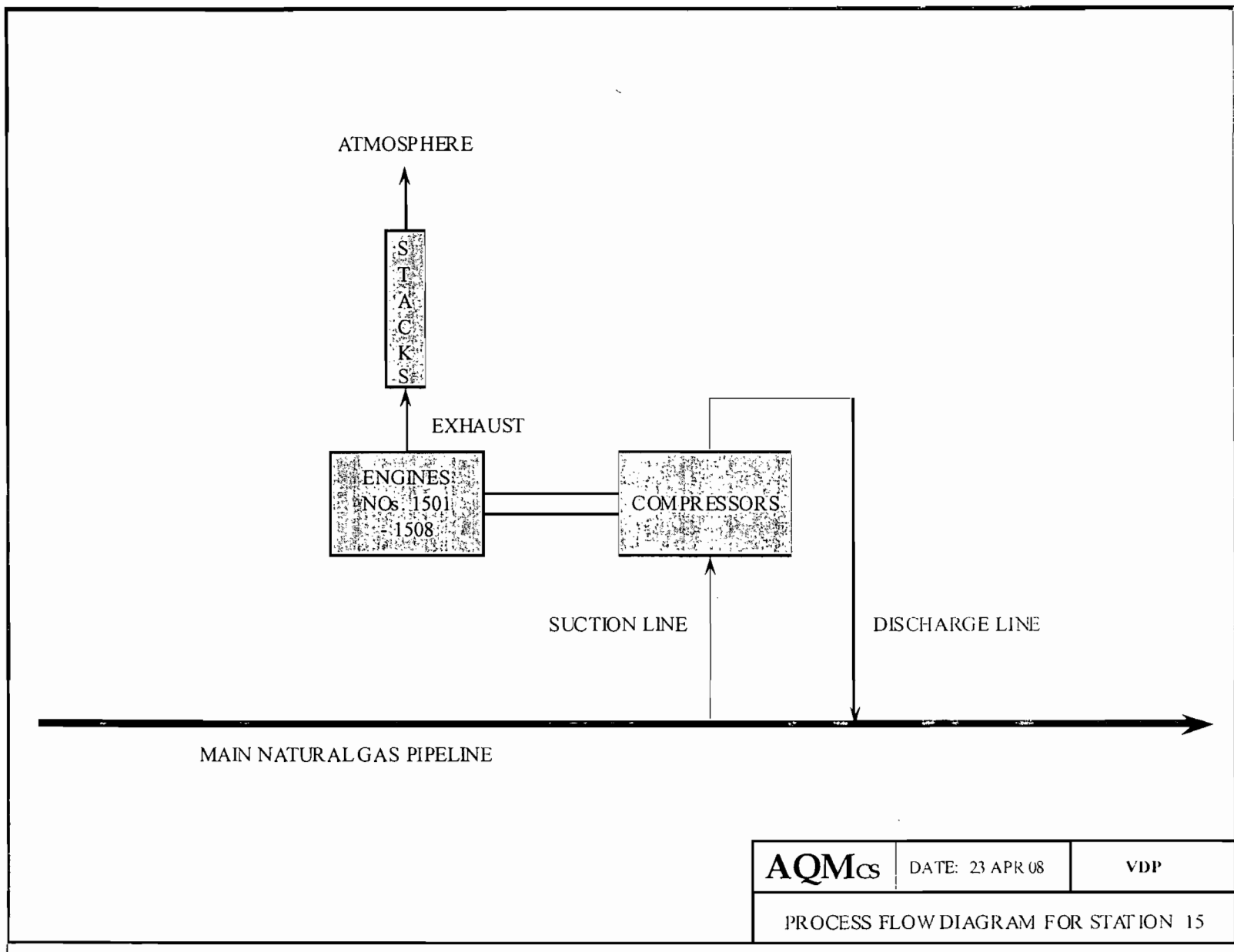

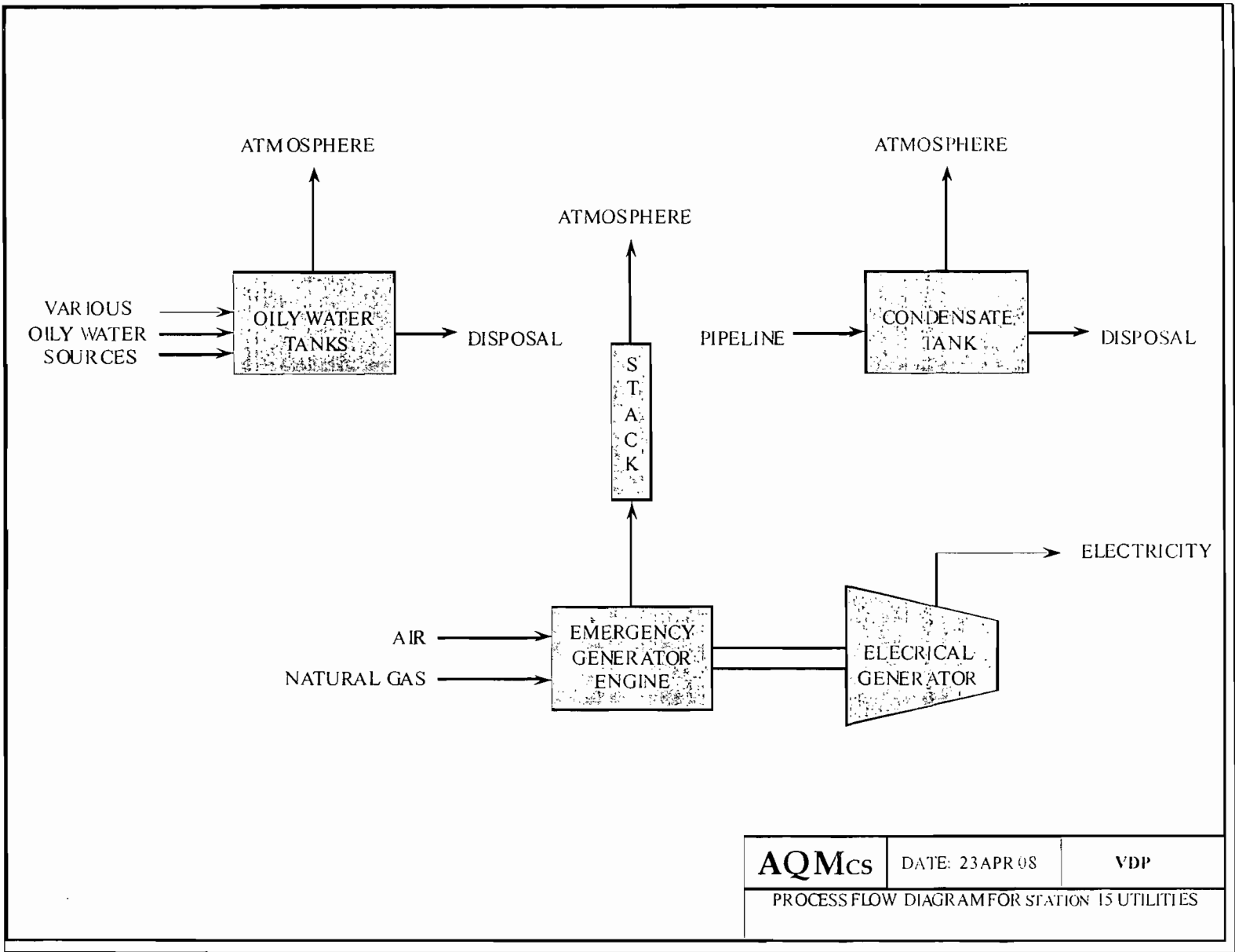

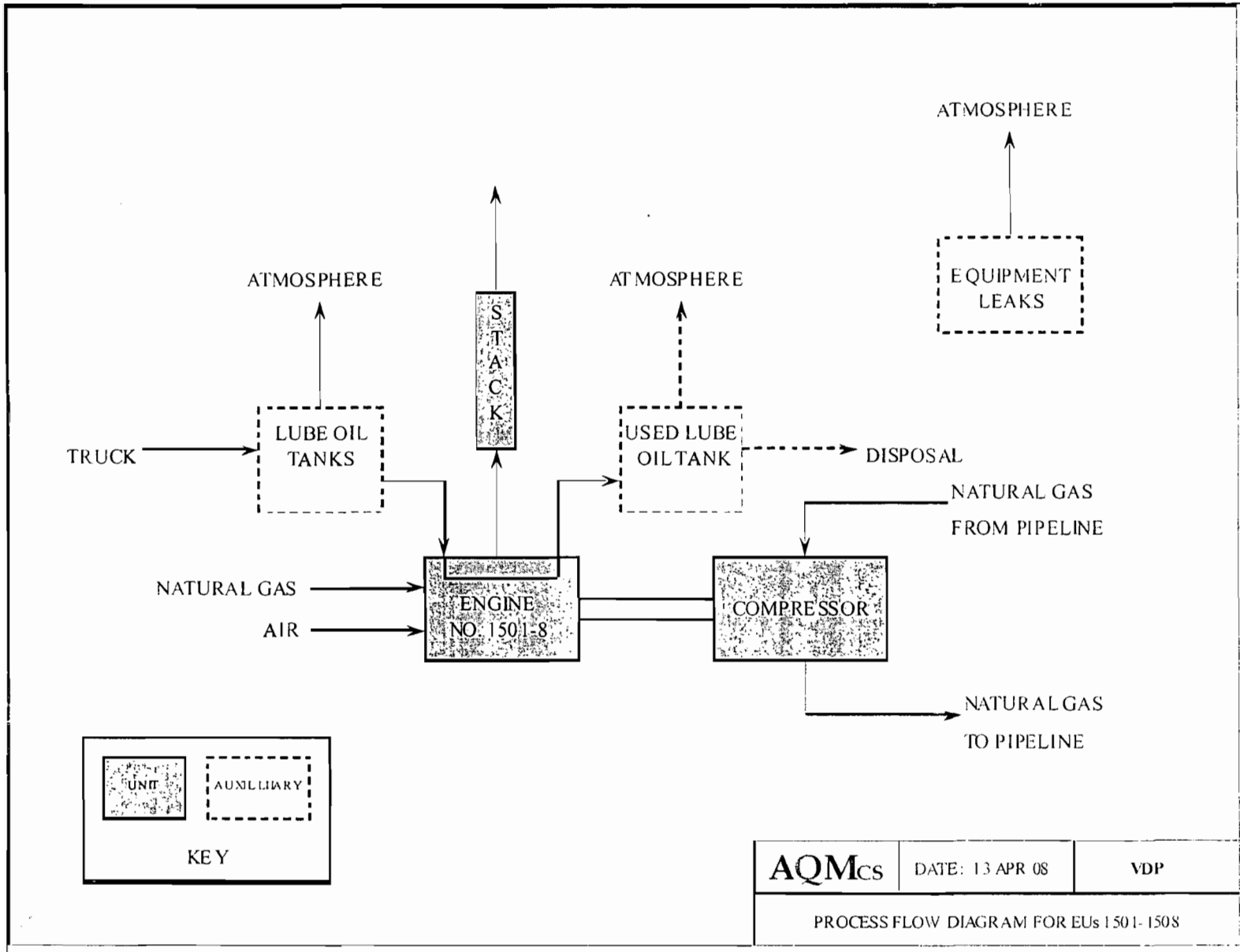

BEST AVAILABLE COPY

Attachment C

Precautions to Prevent Emissions of Unconfined Particulate Mat

Best Available Copy

Precautions to Prevent Emissions of Unconfined Particulate M

Precautions that will be taken to prevent unconfined emissions of unconfined particulate matter include:

- a) Chemical or water application to unpaved roads and unpaved yard areas;
- b) Paving and maintenance of roads, parking areas and yards; Landscaping or planting of vegetation;
- d) Other techniques, as necessary.

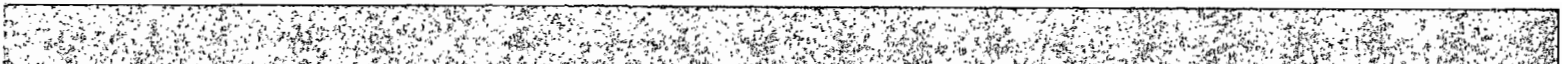

Attachment D

Plot Plan

Best Available Copy

TRANSMISSION\10882 STATION 15\CIVIL\STA 15A\S1-15A-0C-01.DWG I=2400.0000 SEPTEMBER 25, 2008 1:51 PM NORMAN.MERCIOT

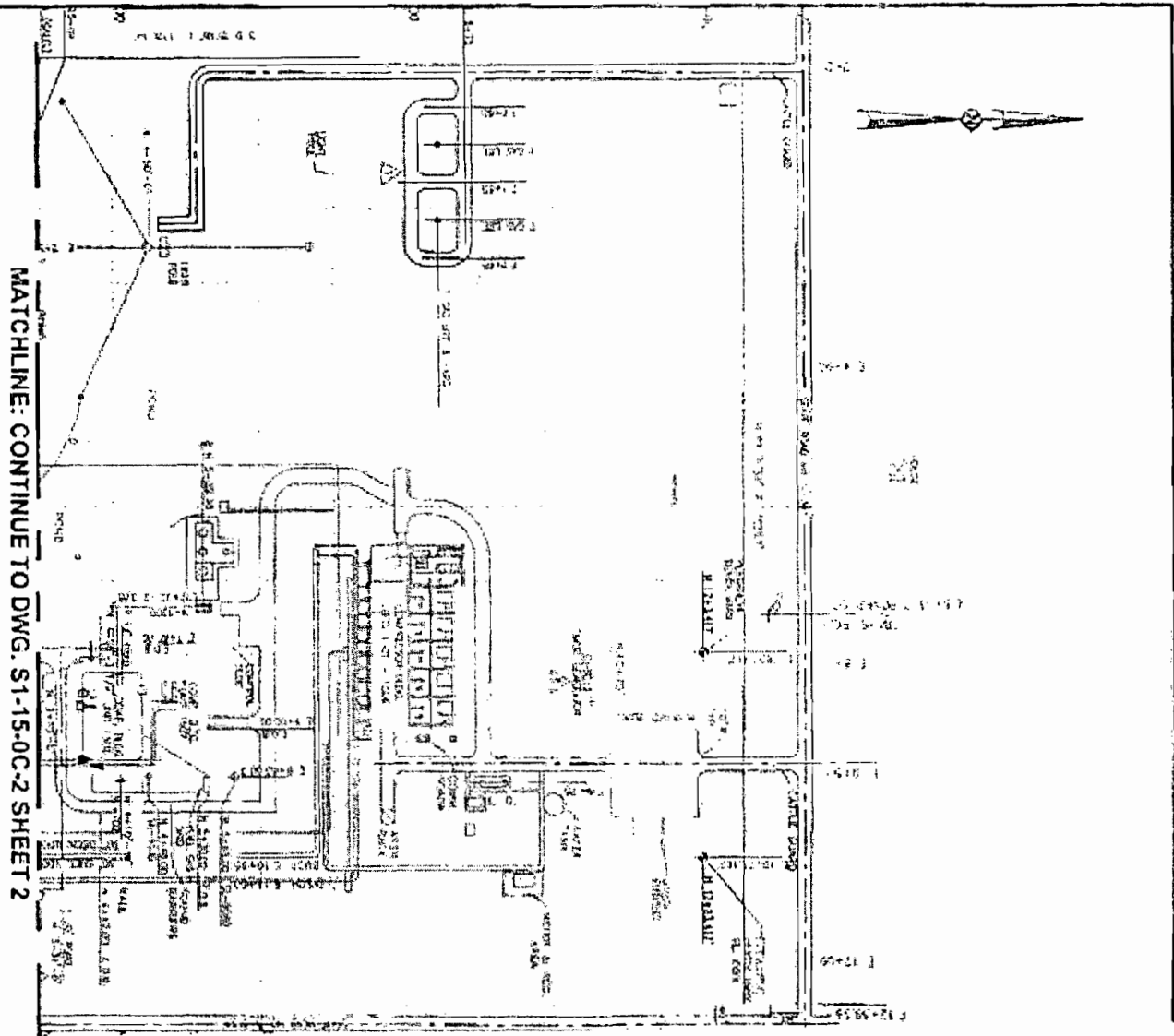

MATCHLINE: CONTINUE TO DWG. S1-15-0C-2 SHEET 2

Best Available Copy

MSBASSON\10662 STATION 19\CIVIL\STA 15A\15A-DC-01.DWG 1-2400.0000 SEPTEMBER 26, 2008 1:49 PM MORHA.WTG:JIT

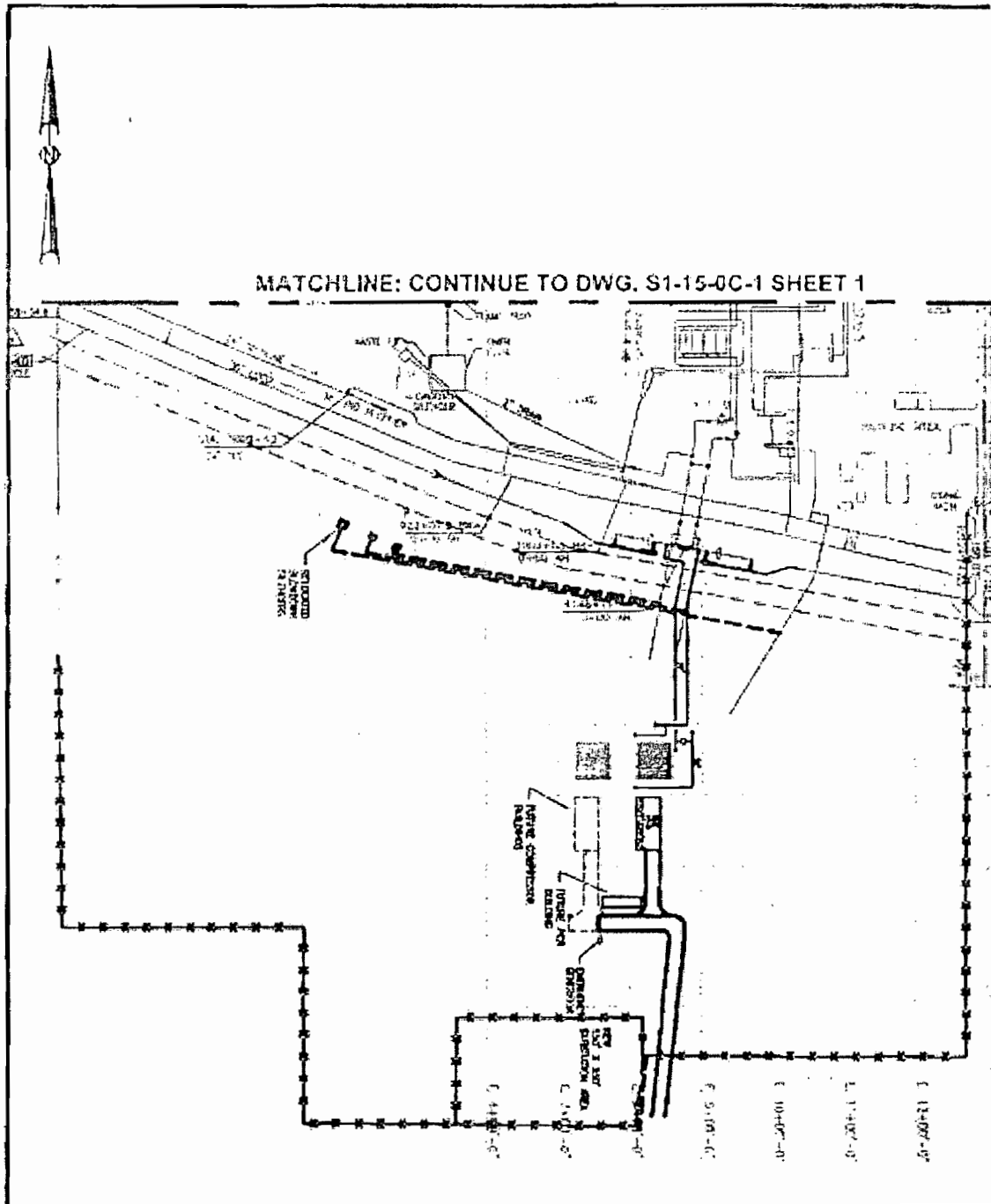



Attachment E

Vendor Information

Generac SG150

BEST AVAILABLE COPY

SG150

Liquid Cooled Gas Engine Genera

Standby Power Rating

150KW 60 Hz / 150KVA 50 Hz

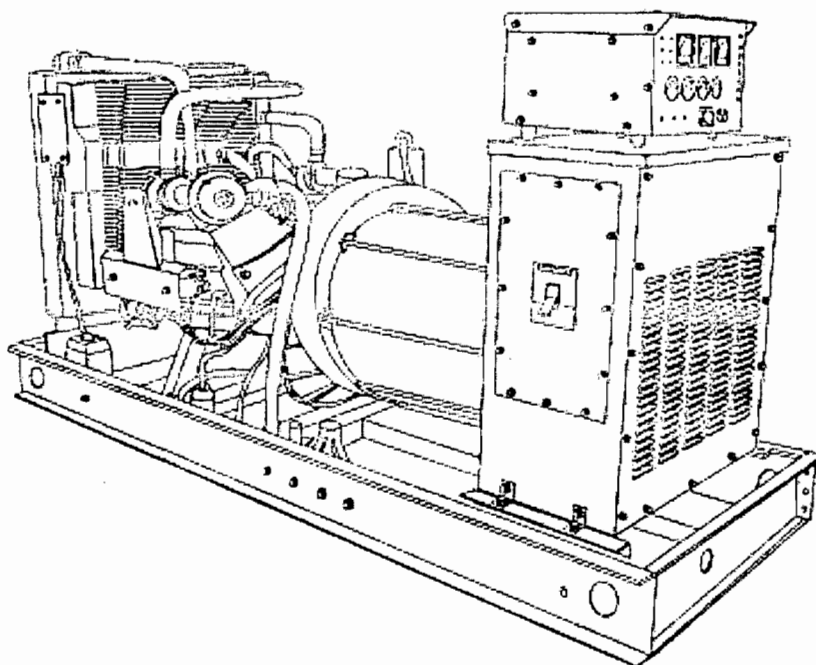

GENERAC 7.4GT

Turbocharged, Aftercooled

FEATURES

- **INNOVATIVE DESIGN & PROTOTYPE TESTING** are key components of GENERAC'S success in "IMPROVING POWER BY DESIGN." But it doesn't stop there. Total commitment to component testing, reliability testing, environmental testing, destruction and life testing, plus testing to applicable CSA, NEMA, EGSA, and other standards, allows you to choose GENERAC POWER SYSTEMS with the confidence that these systems will provide superior performance.
- **TEST CRITERIA:**
 - ✓ PROTOTYPE TESTED
 - ✓ SYSTEM TORSIONAL TESTED
 - ✓ ELECTRO-MAGNETIC INTERFERENCE
 - ✓ NEMA MG1-22 EVALUATION
 - ✓ MOTOR STARTING ABILITY
- **SOLID-STATE, FREQUENCY COMPENSATED V_R REGULATION:** This state-of-the-art power factor regulation system is standard on all Generac made optimized FAST RESPONSE to changing load conditions MAXIMUM MOTOR STARTING CAPABILITY by of torque-matching the surge loads to the engine.
- **SINGLE SOURCE SERVICE RESPONSE** from Generac network provides parts and service know-how for it from the engine to the smallest electronic component never on your own when you own an GENERAC POWER SYSTEM.
- **GENERAC TRANSFER SWITCHES, SWITCHGEAR, ACCESSORIES.** Long life and reliability is synonymous GENERAC POWER SYSTEMS. One reason for this is that the GENERAC product line includes its own

BEST AVAILABLE COPY

APPLICATION & ENGINEERING DATA

GENERATOR SPECIFICATIONS

TYPE Four-pole, revolving field
ROTOR INSULATION Class H
STATOR INSULATION Class H
TOTAL HARMONIC DISTORTION <3%
BALANCED TELEPHONE INFLUENCE FACTOR (TIF) <50
ALTERNATOR Self-ventilated and drip-proof
BEARINGS (PRE-LUBED & SEALED) 1
COUPLING Direct, Flexible Disc
LOAD CAPACITY (STANDBY) 100%

NOTE: Emergency loading in compliance with NFPA 99, NFPA 110, paragraph 5-13.2.6. Generator rating and performance in accordance with ISO8529-5, BS5514, SAE J1349, ISO7046 and DIN6271 standards.

EXCITATION SYSTEM

PERMANENT MAGNET EXCITER Eighteen pole exciter /
Magnetically coupled DC current /
Mounted outboard of main bearing /

REGULATION Solid-state /
 $\pm 1\%$ regulation/

GENERATOR FEATURES

- Four pole, revolving field generator, directly connected to the engine shaft through a heavy-duty, flexible disc for permanent alignment.
- Generator meets temperature rise standards for class "F" insulation as defined by NEMA MG1-22 and NEMA MG1-1.
- Rotor and stator and other insulation is impregnated twice with class "H" varnish.
- All models have passed a three-phase symmetrical short circuit test to assure system protection and reliability.
- Unit tested for motor-starting ability by measuring instantaneous voltage dip with a waveform data acquisition system.
- All models utilize an advanced wire harness design for reliable interconnection within the circuitry.
- Magnetic circuit, including amortisseur windings, teeth and skewed stator design, provides a minimal level of waveform distortion and an electromagnetic interference level which meets accepted requirements for standard AM radio, TV, and marine radio telephone applications.

ENGINE SPECIFICATIONS

MAKE
MODEL
CYLINDERS
DISPLACEMENT 7.4 Liter
BORE 108
STROKE 103
COMPRESSION RATIO
INTAKE AIR Twin Turbocharged
NUMBER OF MAIN BEARINGS
CONNECTING RODS 8-Drop
CYLINDER HEAD
PISTONS 8-Notched Head, All
CRANKSHAFT f

VALVE TRAIN

LIFTER TYPE
INTAKE VALVE MATERIAL Heat Resistant
EXHAUST VALVE MATERIAL
HARDENED VALVE SEATS
.....

ENGINE GOVERNOR

ELECTRONIC
FREQUENCY REGULATION, NO-LOAD TO FULL LOAD
STEADY STATE REGULATION
.....

LUBRICATION SYSTEM

TYPE OF OIL PUMP
OIL FILTER Full Flow
CRANKCASE CAPACITY 7.5 L

COOLING SYSTEM

TYPE OF SYSTEM Pressurized, closed
WATER PUMP Pre-lubed,
TYPE OF FAN Pulse
NUMBER OF FAN BLADES
DIAMETER OF FAN 660.4
COOLANT HEATER 12

FUEL SYSTEM

FUEL - Material Gas
CARBURETOR Twin
SECONDARY FUEL REGULATOR
.....

BEST AVAILABLE COPY

GENE
POWER SYST

SG150

OPERATING DATA

	STANDBY		NO PRIME RATING AV.
	SG150		
GENERATOR OUTPUT VOLTAGE/KW-60Hz	NO	BASELINE	
120/240V, 1-phase, 1.0 pf	150	205	
120/208V, 3-phase, 0.8 pf	150	221	
120/240V, 3-phase, 0.8 pf	150	152	
277/480V, 3-phase, 0.8 pf	150	238	
600V, 3-phase, 0.8 pf	150	181	
GENERATOR OUTPUT VOLTAGE/KVA-60Hz	NO	BASELINE	
110/220V, 1 phase, 1.0 pf	150	263	
115/200V, 3-phase, 0.8 pf	150	434	
120/208V, 3-phase, 0.8 pf	150	434	
231/400V, 3-phase, 0.8 pf	150	217	
480V, 3-phase, 0.8 pf	150	181	
MOTOR STARTING			
Maximum at 50% instantaneous voltage dip with standard alternator	240V	480V	
	390	405	
with optional alternator	500	630	
FUEL	N.D.		
Fuel consumption—60 Hz—100% Load			
ft. ³ /hr.		2300	
m ³ /hr.		67.8	
Fuel consumption—50 Hz—100% Load			
ft. ³ /hr.		1950	
m ³ /hr.		56.5	
COOLING			
Coolant capacity			
System lit.(US gal.)		20 (5)	
Engine lit.(US gal.)		8 (2)	
Radiator lit.(US gal.)		12 (3)	
Coolant flow/min.			
60 Hz lit.(US gal.)		189 (50)	
50 Hz lit.(US gal.)		158 (42)	
Heat rejection to coolant		751,000	
BTU/hr.			
Inlet air			
60 Hz m ³ /min. (cfm)		250 (8600)	
50 Hz m ³ /min. (cfm)		208 (7330)	
Max. inlet air temperature		110	
°F			
COMBUSTION AIR REQUIREMENTS			
Flow at rated power			
60 Hz m ³ /min. (cfm)		10.8 (425)	
50 Hz m ³ /min. (cfm)		9.0 (340)	
EXHAUST			
Exhaust flow at rated output			
60 Hz m ³ /min. (cfm)		44.2 (1560)	
50 Hz m ³ /min. (cfm)		30.7 (1090)	
Maximum recommended back pressure		5.0 (1.5")	
Kpa (Hq)			
Exhaust temperature at rated output		815(1500)1500Max	
°C (°F)			
Exhaust outlet size		(2) - 15"	
N.P.T. (female)			
ENGINE			
Rated RPM			
60 Hz		2700	
50 Hz		2300	
HP at rated kW			
60 Hz		223	

BEST AVAILABLE COPY

STANDARD ENGINE & SAFETY FEATURES

- High Coolant Temperature Automatic Shutdown
- Low Coolant Level Automatic Shutdown
- Low Oil Pressure Automatic Shutdown
- Overspeed Automatic Shutdown (Solid-state)
- Crank Limiter (Solid-state)
- Oil Drain Extension
- Radiator Drain Extension
- Factory-Installed Cool Flow Radiator
- Closed Coolant Recovery System
- UV/Ozone Resistant Hoses
- Rubber-Booted Engine Electrical Connections
- Fuel Lockoff Solenoid
- Secondary Fuel Regulator
- Stainless Steel Flexible Exhaust Connection
- Battery Charge Assistor
- Battery Cables
- Battery Tray
- Vibration Isolation of Unit to Mounting Base
- 12 Volt, Solenoid-Activated Starter Motor
- Air CleanerS
- Fan Guard
- Control Console
- Electronic Governor

OPTIONS

■ OPTIONAL COOLING SYSTEM ACCESSORIES

- Radiator Exit Adapter
- 208/240V Coolant Heater

■ OPTIONAL FUEL ACCESSORIES

- Flexible Fuel Lines

■ OPTIONAL EXHAUST ACCESSORIES

- Critical Exhaust Silencer

■ OPTIONAL ELECTRICAL ACCESSORIES

- Battery, 12 Volt, 135 A.H., 4DL
- Battery Heater
- 2A Battery Charger
- 10A Dual Rate Battery Charger

■ OPTIONAL ALTERNATOR ACCESSORIES

- Alternator Strip Heater
- Alternator Tropicalization
- Voltage Changeover Switch
- Main Line Circuit Breaker

■ CONTROL CONSOLE OPTIONS

- See control console specification sheet

■ ADDITIONAL OPTIONAL EQUIPMENT

- Automatic Transfer Switch
- Weather Protective Enclosure (Locking Type)
- Isochronous Governor
- 3 Light Remote Annunciator
- 5 Light Remote Annunciator
- 20 Light Remote Annunciator
- Remote Relay Panel
- Oil Heater
- Export Boxing

Distributed by:

Design and specification subject to change without notice. Dimensions shown are approximate. Contact your Deere dealer for detailed drawings. DO NOT USE THESE DIMENSIONS FOR INSTALLATION.

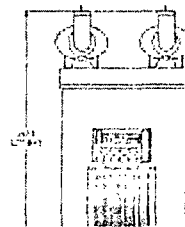
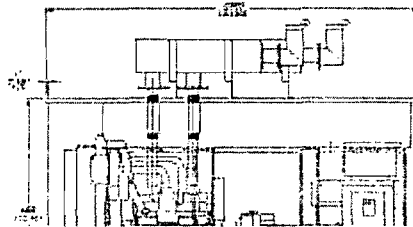



Attachment F
Emission Calculations

BEST AVAILABLE COPY

Compressor Station No. 15

Emergency Gen. No. 4 EPN:

NOx Emissions: (Based on Vendor Data)

$$\begin{aligned} \text{lb NOx/hr} &= (\text{g/bhp-hr})(\text{bhp})(1 \text{ lb}/453.59 \text{ g}) \\ &= (2.00 \text{ g/bhp-hr})(223 \text{ bhp})(1 \text{ lb}/453.59 \text{ g}) \\ &= 0.983 \end{aligned}$$

$$\begin{aligned} \text{tons NOx/yr} &= (\text{lb NOx/hr})(\text{hr/yr})(1 \text{ ton}/2000 \text{ lb}) \\ &= (0.98 \text{ lb NOx/hr})(100 \text{ hr/yr})(1 \text{ ton}/2000 \text{ lb}) \\ &= 0.0492 \end{aligned}$$

CO Emissions: (Based on Vendor Data)

$$\begin{aligned} \text{lb CO/hr} &= (\text{g/bhp-hr})(\text{bhp})(1 \text{ lb}/453.59 \text{ g}) \\ &= (4.0 \text{ g/bhp-hr})(223 \text{ bhp})(1 \text{ lb}/453.59 \text{ g}) \\ &= 1.966 \end{aligned}$$

$$\begin{aligned} \text{tons CO/yr} &= (\text{lb CO/hr})(\text{hr/yr})(1 \text{ ton}/2000 \text{ lb}) \\ &= (1.97 \text{ lb CO/hr})(100 \text{ hr/yr})(1 \text{ ton}/2000 \text{ lb}) \\ &= 0.098 \end{aligned}$$

VOC Emissions: (Based on Vendor Data)

$$\begin{aligned} \text{lb VOC/hr} &= (\text{g/bhp-hr})(\text{bhp})(1 \text{ lb}/453.59 \text{ g}) \\ &= (1.0 \text{ g/bhp-hr})(223 \text{ bhp})(1 \text{ lb}/453.59 \text{ g}) \\ &= 0.492 \end{aligned}$$

$$\begin{aligned} \text{tons VOC/yr} &= (\text{lb VOC/hr})(\text{hr/yr})(1 \text{ ton}/2000 \text{ lb}) \\ &= (0.49 \text{ lb VOC/hr})(100 \text{ hr/yr})(1 \text{ ton}/2000 \text{ lb}) \\ &= 0.0246 \end{aligned}$$

SO2 Emissions: (Based on FERC Limits)

$$\begin{aligned} \text{lb S/hr} &= (\text{gr S}/100 \text{ scf})(\text{scf/hr})(1 \text{ lb}/7000 \text{ gr}) \\ &= (10 \text{ gr S}/100 \text{ scf})(2395 \text{ scf/hr})(1 \text{ lb}) \\ &= 0.034 \end{aligned}$$

$$\begin{aligned} \text{lb SO2/hr} &= (\text{lb S/hr})(2 \text{ lb SO2}/\text{lb S}) \\ &= (0.034 \text{ lb S/hr})(2 \text{ lb SO2}/\text{lb S}) \\ &= 0.068 \end{aligned}$$

$$\begin{aligned} \text{tons SO2/yr} &= (\text{lb SO2/hr})(\text{hr/yr})(1 \text{ ton}/2000 \text{ lb}) \\ &= (0.068 \text{ lb SO2/hr})(100 \text{ hr/yr})(1 \text{ ton}) \\ &= 0.003 \end{aligned}$$

PM Emissions: (Based on AP-42 Table 3.2-3, 7/00)

$$\begin{aligned} \text{lb PM/hr} &= (\text{lb PM}/\text{MMBtu})(\text{MMBtu/hr}) \\ &= (0.01941 \text{ lb}/\text{MMBtu})(2.49 \text{ MMBtu/hr}) \\ &= 0.048 \end{aligned}$$

$$\begin{aligned} \text{tons PM/yr} &= (\text{lb PM/hr})(\text{hr/yr})(1 \text{ ton}/2000 \text{ lb}) \\ &= (0.048 \text{ lb PM/hr})(100 \text{ hr/yr})(1 \text{ ton}) \\ &= 0.0024 \end{aligned}$$

HAPs Emissions: (Based on AP-42 Table 3.2-3, 7/00)

$$\begin{aligned} \text{lb HAP/hr} &= (\text{lb HAP}/\text{MMBtu})(\text{MMBtu/hr}) \\ &= (0.0234 \text{ lb}/\text{MMBtu})(2.49 \text{ MMBtu/hr}) \\ &= 0.0586 \end{aligned}$$

$$\begin{aligned} \text{tons HAP/yr} &= (\text{lb HAP/hr})(\text{hr/yr})(1 \text{ ton}/2000 \text{ lb}) \\ &= (0.058 \text{ lb HAP/hr})(100 \text{ hr/yr})(1 \text{ ton}) \\ &= 0.0029 \end{aligned}$$



Attachment G

Fuel Analysis

BEST AVAILABLE COPY

FTWSCB1.ener	East System Chromatographs								01-Aug-2008 14:05:09
	Station 15 36"	Station 15 30"	Station 16	Station 18	Jacksonville Lat	Gainsville Lab	Brandy Branch	Station 21	
n-Hexanes +	0.0698	0.0706	0.0627	0.0199	0.0058	0.0638	0.0013	0.0453	
Nitrogen	0.5661	0.5581	0.5374	0.4067	0.0616	0.5267	0.0184	0.4515	
Methane	95.5536	95.5834	95.5528	95.9043	96.5431	95.6856	96.6087	95.6529	
Carbon Dioxide	0.9859	0.9896	0.9931	0.7936	0.1266	1.0224	0.0153	0.7481	
Ethane	2.2210	2.2010	2.2452	2.3074	2.6850	2.1642	2.7702	2.4459	
Propane	0.3579	0.3530	0.3637	0.3569	0.4396	0.3325	0.4590	0.4177	
Iso-Butane	0.0806	0.0796	0.0814	0.0710	0.0704	0.0728	0.0702	0.0854	
n-Butane	0.0944	0.0933	0.0947	0.0716	0.0563	0.0757	0.0515	0.0923	
Iso-Pentane	0.0406	0.0411	0.0395	0.0270	0.0076	0.0343	0.0039	0.0356	
n-Pentane	0.0301	0.0304	0.0295	0.0187	0.0038	0.0229	0.0016	0.0253	
Un-normalized Totals	100.00	100.11	99.91	99.78	100.08	100.00	99.85	99.40	
Specific Gravity	0.5869	0.5873	0.5868	0.5831	0.5759	0.5857	0.5750	0.5850	
BTU / cu. ft	1030.2	1029.5	1030.4	1031.8	1043.2	1029.1	1045.2	1035.1	
	CR15		BRO1	CR18	CRJX	GLAB	CRBB	CR21	
Dew Point and H2S		Recal		West Chromatographs			East On Line Chromatographs		

Attachment H

List of Exempt Emissions Units

List of Exempt Emissions Units

1. Fugitive emissions from component leaks