

**Prickett, Patricia**

---

**From:** Mike Byrd [mbyrd@raineyconstruction.com]  
**Sent:** Friday, June 10, 2011 1:17 PM  
**To:** Prickett, Patricia  
**Subject:** RE: RAINEY ASPHALT/WILDWOOD PLANT Number 1; 1190050-003-AC

Pat thank you very much for your help in getting this permit we have received it and everything is ok.  
Thank you, Mike

---

**From:** Prickett, Patricia [<mailto:Patricia.Prickett@dep.state.fl.us>]  
**Sent:** Friday, June 10, 2011 12:54 PM  
**To:** Mike Byrd  
**Cc:** Flavors, Brandy  
**Subject:** FW: RAINEY ASPHALT/WILDWOOD PLANT Number 1; 1190050-003-AC  
**Importance:** High

Per your request, please see email below. As we discussed on the phone today, I need a response from Ike Rainey stating he was able to access the Link and Attachment. If he is unable to send response, someone else may respond for him stating they are responding on his behalf.  
Thank you for your help,

*Patricia Prickett*  
Patricia Prickett  
Senior Clerk  
FDEP - Air Program - SWD  
(813) 632-7600 Ext 102

Email: [Patricia.Prickett@dep.state.fl.us](mailto:Patricia.Prickett@dep.state.fl.us)

Please Note: Florida has a very broad Public Records Law. Most written communications to or from State and Local Officials regarding State or Local business are public records available to the public and media upon request. Your email communications may therefore be subject to public disclosure.

*The Department of Environmental Protection values your feedback as a customer. DEP Secretary Herschel T. Vinyard Jr. is committed to continuously assessing and improving the level and quality of services provided to you. Please take a few minutes to comment on the quality of service you received. Simply click on [this link to the DEP Customer Survey](#). Thank you in advance for completing the survey.*

**From:** Prickett, Patricia  
**Sent:** Wednesday, June 01, 2011 1:50 PM  
**To:** 'irainey@raineyconstruction.com'  
**Cc:** 'Sara Greivell'; 'jshow@cfl.rr.com'; Flavors, Brandy; Zhang-Torres  
**Subject:** RAINEY ASPHALT/WILDWOOD PLANT Number 1; 1190050-003-AC  
**Importance:** High

Attention: Mr. Ike Rainey, Manager

Owner/Company Name: RAINEY ASPHALT LLC  
Facility Name: RAINEY ASPHALT/WILDWOOD PLANT Number1  
Project Number: 1190050-003-AC  
Permit Status: FINAL

Permit Activity: CONSTRUCTION

Facility County: SUMTER

Dear Mr. Rainey:

**IMPORTANT: We must receive verification, by email stating that you are able to access the attachment(s), and the LINK shown below. Your immediate reply will preclude subsequent e-mail transmissions to verify accessibility of the document(s).**

Click on the following link to access the permit project documents:

[http://ARM-PERMIT2K.dep.state.fl.us/adh/prod/pdf\\_permit\\_zip\\_files/1190050.003.AC.F\\_pdf.zip](http://ARM-PERMIT2K.dep.state.fl.us/adh/prod/pdf_permit_zip_files/1190050.003.AC.F_pdf.zip)

Attached is the official **Final Permit** for the project referenced above. This Final Permit (including the Final Permit and the Attachments) has been posted on the Department of Environmental Protection's website.

Click on the link displayed above to access the permit project documents and send a "reply" message verifying receipt of the document(s) provided in the link; this may be done by selecting "Reply" on the menu bar of your e-mail software, noting that you can view the documents, and then selecting "Send".

Permit project documents that are addressed in this email may require immediate action within a specified time frame. Please open and review the document(s) as soon as possible, and verify that they are accessible. Please advise this office of any changes to your e-mail address or that of the Engineer-of-Record.

The Southwest District is issuing electronic documents for permits, notices and other correspondence in lieu of hard copies through the United States Postal System, to provide greater service to the applicant and the engineering community. Access these documents by clicking on the link provided above, or search for other project documents using the "*Air Permit Documents Search*" website at <http://www.dep.state.fl.us/air/emission/apds/default.asp>.

If you should have any questions, please contact Brandy Flavors, the Permit Engineer at [Brandy.Flavors@dep.state.fl.us](mailto:Brandy.Flavors@dep.state.fl.us).

Sincerely,

*Patricia Prickett*

Patricia Prickett  
Senior Clerk  
FDEP - Air Program - SWD  
(813) 632-7600 Ext 102

Email: [Patricia.Prickett@dep.state.fl.us](mailto:Patricia.Prickett@dep.state.fl.us)

Please Note: Florida has a very broad Public Records Law. Most written communications to or from State and Local Officials regarding State or Local business are public records available to the public and media upon request. Your email communications may therefore be subject to public disclosure.

**Prickett, Patricia**

---

**From:** Prickett, Patricia  
**Sent:** Friday, June 10, 2011 1:10 PM  
**To:** 'mbyrd@raineyasphalt.com'  
**Subject:** See Link Below

Click on the following link to access the permit project documents:

[http://ARM-PERMIT2K.dep.state.fl.us/adh/prod/pdf\\_permit\\_zip\\_files/1190050.003.AC.F\\_pdf.zip](http://ARM-PERMIT2K.dep.state.fl.us/adh/prod/pdf_permit_zip_files/1190050.003.AC.F_pdf.zip)

*Patricia Prickett*

Patricia Prickett  
Senior Clerk  
FDEP - Air Program - SWD  
(813) 632-7600 Ext 102

Email: [Patricia.Prickett@dep.state.fl.us](mailto:Patricia.Prickett@dep.state.fl.us)

*Please Note: Florida has a very broad Public Records Law. Most written communications to or from State and Local Officials regarding State or Local business are public records available to the public and media upon request. Your email communications may therefore be subject to public disclosure.*

**Prickett, Patricia**

---

**From:** Mike Byrd [mbyrd@raineyconstruction.com]  
**Sent:** Friday, June 10, 2011 1:04 PM  
**Subject:** Read: RAINEY ASPHALT/WILDWOOD PLANT Number 1; 1190050-003-AC

Your message was read on Friday, June 10, 2011 1:03:55 PM (GMT-05:00) Eastern Time (US & Canada).

**Prickett, Patricia**

---

**From:** Prickett, Patricia  
**Sent:** Friday, June 10, 2011 12:54 PM  
**To:** 'mbyrd@raineyasphalt.com'  
**Cc:** Flavors, Brandy  
**Subject:** FW: RAINEY ASPHALT/WILDWOOD PLANT Number 1; 1190050-003-AC  
**Attachments:** 1190050.003.ac.f.rainey asphalt.SignaturePage.pdf

**Importance:** High

<b>Tracking:</b>	<b>Recipient</b>	<b>Delivery</b>
	'mbyrd@raineyasphalt.com'	
	Flavors, Brandy	Delivered: 6/10/2011 12:54 PM

Per your request, please see email below. As we discussed on the phone today, I need a response from Ike Rainey stating he was able to access the Link and Attachment. If he is unable to send response, someone else may respond for him stating they are responding on his behalf.  
Thank you for your help,

*Patricia Prickett*

Patricia Prickett  
Senior Clerk  
FDEP - Air Program - SWD  
(813) 632-7600 Ext 102

Email: [Patricia.Prickett@dep.state.fl.us](mailto:Patricia.Prickett@dep.state.fl.us)

Please Note: Florida has a very broad Public Records Law. Most written communications to or from State and Local Officials regarding State or Local business are public records available to the public and media upon request. Your email communications may therefore be subject to public disclosure.

---

**From:** Prickett, Patricia  
**Sent:** Wednesday, June 01, 2011 1:50 PM  
**To:** 'irainey@raineyconstruction.com'  
**Cc:** 'Sara Greivell'; 'jshow@cfl.rr.com'; Flavors, Brandy; Zhang-Torres  
**Subject:** RAINEY ASPHALT/WILDWOOD PLANT Number 1; 1190050-003-AC  
**Importance:** High

Attention: Mr. Ike Rainey, Manager

Owner/Company Name: RAINEY ASPHALT LLC  
Facility Name: RAINEY ASPHALT/WILDWOOD PLANT Number1  
Project Number: 1190050-003-AC  
Permit Status: FINAL  
Permit Activity: CONSTRUCTION  
Facility County: SUMTER

Dear Mr. Rainey:

**IMPORTANT: We must receive verification, by email stating that you are able to access the attachment(s), and the LINK shown below. Your immediate reply will preclude subsequent e-mail transmissions to verify accessibility of the document(s).**

Click on the following link to access the permit project documents:

[http://ARM-PERMIT2K.dep.state.fl.us/adh/prod/pdf\\_permit\\_zip\\_files/1190050.003.AC.F\\_pdf.zip](http://ARM-PERMIT2K.dep.state.fl.us/adh/prod/pdf_permit_zip_files/1190050.003.AC.F_pdf.zip)

Attached is the official **Final Permit** for the project referenced above. This Final Permit (including the **Final Permit and the Attachments**) has been posted on the Department of Environmental Protection's website.

Click on the link displayed above to access the permit project documents and send a "reply" message verifying receipt of the document(s) provided in the link; this may be done by selecting "Reply" on the menu bar of your e-mail software, noting that you can view the documents, and then selecting "Send".

Permit project documents that are addressed in this email may require immediate action within a specified time frame. Please open and review the document(s) as soon as possible, and verify that they are accessible. Please advise this office of any changes to your e-mail address or that of the Engineer-of-Record.

The Southwest District is issuing electronic documents for permits, notices and other correspondence in lieu of hard copies through the United States Postal System, to provide greater service to the applicant and the engineering community. Access these documents by clicking on the link provided above, or search for other project documents using the "*Air Permit Documents Search*" website at <http://www.dep.state.fl.us/air/emission/apds/default.asp>.

If you should have any questions, please contact Brandy Flavors, the Permit Engineer at [Brandy.Flavors@dep.state.fl.us](mailto:Brandy.Flavors@dep.state.fl.us).

Sincerely,

*Patricia Prickett*

Patricia Prickett  
Senior Clerk  
FDEP - Air Program - SWD  
(813) 632-7600 Ext 102

Email: [Patricia.Prickett@dep.state.fl.us](mailto:Patricia.Prickett@dep.state.fl.us)

*Please Note: Florida has a very broad Public Records Law. Most written communications to or from State and Local Officials regarding State or Local business are public records available to the public and media upon request. Your email communications may therefore be subject to public disclosure.*

## Prickett, Patricia

---

**From:** Prickett, Patricia  
**Sent:** Thursday, June 02, 2011 3:24 PM  
**To:** 'irainey@raineyconstruction.com'  
**Cc:** Flavors, Brandy  
**Subject:** FW: RAINEY ASPHALT/WILDWOOD PLANT Number 1; 1190050-003-AC  
**Attachments:** 1190050.003.ac.f.rainey asphalt.SignaturePage.pdf

**Importance:** High

ATTENTION: Mr. Name/Title  
**2<sup>nd</sup> Request**

Dear Mr. Rainey:

The e-mail shown below was sent to you June 1, 2011. **We have not received confirmation that you were able to access the link and document(s) attached to the e-mail. Please confirm receipt/access to me at your earliest convenience.**

If you are unable to send the email, please have a designated representative send it for you specifying they are responding on your behalf.

The Southwest District is sending electronic versions of these documents rather than sending them Return Receipt Requested via the US Postal service. Your "receipt confirmation" reply serves the same purpose as tracking the receipt of the signed "Return Receipt" card from the US Postal Service. Please let me know if you have any questions.

Thank you for your help,

Sincerely,

*Patricia Prickett*

Patricia Prickett  
Senior Clerk  
FDEP - Air Program - SWD  
(813) 632-7600 Ext 102

Email: [Patricia.Prickett@dep.state.fl.us](mailto:Patricia.Prickett@dep.state.fl.us)

Please Note: Florida has a very broad Public Records Law. Most written communications to or from State and Local Officials regarding State or Local business are public records available to the public and media upon request. Your email communications may therefore be subject to public disclosure.

---

**From:** Prickett, Patricia  
**Sent:** Wednesday, June 01, 2011 1:50 PM  
**To:** 'irainey@raineyconstruction.com'  
**Cc:** 'Sara Greivell'; 'jshow@cfl.rr.com'; Flavors, Brandy; Zhang-Torres  
**Subject:** RAINEY ASPHALT/WILDWOOD PLANT Number 1; 1190050-003-AC  
**Importance:** High

Attention: Mr. Ike Rainey, Manager

Owner/Company Name: RAINEY ASPHALT LLC  
Facility Name: RAINEY ASPHALT/WILDWOOD PLANT Number1  
Project Number: 1190050-003-AC  
Permit Status: FINAL  
Permit Activity: CONSTRUCTION  
Facility County: SUMTER

Dear Mr. Rainey:

**IMPORTANT: We must receive verification, by email stating that you are able to access the attachment(s), and the LINK shown below. Your immediate reply will preclude subsequent e-mail transmissions to verify accessibility of the document(s).**

Click on the following link to access the permit project documents:

[http://ARM-PERMIT2K.dep.state.fl.us/adh/prod/pdf\\_permit\\_zip\\_files/1190050.003.AC.F\\_pdf.zip](http://ARM-PERMIT2K.dep.state.fl.us/adh/prod/pdf_permit_zip_files/1190050.003.AC.F_pdf.zip)

Attached is the official **Final Permit** for the project referenced above. This Final Permit (including the Final Permit and the Attachments) has been posted on the Department of Environmental Protection's website.

Click on the link displayed above to access the permit project documents and send a "reply" message verifying receipt of the document(s) provided in the link; this may be done by selecting "Reply" on the menu bar of your e-mail software, noting that you can view the documents, and then selecting "Send".

Permit project documents that are addressed in this email may require immediate action within a specified time frame. Please open and review the document(s) as soon as possible, and verify that they are accessible. Please advise this office of any changes to your e-mail address or that of the Engineer-of-Record.

The Southwest District is issuing electronic documents for permits, notices and other correspondence in lieu of hard copies through the United States Postal System, to provide greater service to the applicant and the engineering community. Access these documents by clicking on the link provided above, or search for other project documents using the "Air Permit Documents Search" website at <http://www.dep.state.fl.us/air/emission/apds/default.asp>.

If you should have any questions, please contact Brandy Flavors, the Permit Engineer at [Brandy.Flavors@dep.state.fl.us](mailto:Brandy.Flavors@dep.state.fl.us).

Sincerely,

*Patricia Prickett*

Patricia Prickett  
Senior Clerk  
FDEP - Air Program - SWD  
(813) 632-7600 Ext 102

Email: [Patricia.Prickett@dep.state.fl.us](mailto:Patricia.Prickett@dep.state.fl.us)

Please Note: Florida has a very broad Public Records Law. Most written communications to or from State and Local Officials regarding State or Local business are public records available to the public and media upon request. Your email communications may therefore be subject to public disclosure.



**Prickett, Patricia**

---

**From:** Prickett, Patricia  
**Sent:** Wednesday, June 01, 2011 1:50 PM  
**To:** 'irainey@raineyconstruction.com'  
**Cc:** 'Sara Greivell'; 'jshow@cfl.rr.com'; Flavors, Brandy; Zhang-Torres  
**Subject:** RAINEY ASPHALT/WILDWOOD PLANT Number 1; 1190050-003-AC  
**Attachments:** 1190050.003.ac.f.rainey asphalt.SignaturePage.pdf

**Importance:** High

<b>Tracking:</b>	<b>Recipient</b>	<b>Delivery</b>
	'irainey@raineyconstruction.com'	
	'Sara Greivell'	
	'jshow@cfl.rr.com'	
	Flavors, Brandy	Delivered: 6/1/2011 1:50 PM
	Zhang-Torres	Delivered: 6/1/2011 1:50 PM

Attention: Mr. Ike Rainey, Manager

Owner/Company Name: RAINEY ASPHALT LLC  
Facility Name: RAINEY ASPHALT/WILDWOOD PLANT Number1  
Project Number: 1190050-003-AC  
Permit Status: FINAL  
Permit Activity: CONSTRUCTION  
Facility County: SUMTER

Dear Mr. Rainey:

**IMPORTANT: We must receive verification, by email stating that you are able to access the attachment(s), and the LINK shown below. Your immediate reply will preclude subsequent e-mail transmissions to verify accessibility of the document(s).**

Click on the following link to access the permit project documents:  
[http://ARM-PERMIT2K.dep.state.fl.us/adh/prod/pdf\\_permit\\_zip\\_files/1190050.003.AC.F\\_pdf.zip](http://ARM-PERMIT2K.dep.state.fl.us/adh/prod/pdf_permit_zip_files/1190050.003.AC.F_pdf.zip)

Attached is the official **Final Permit** for the project referenced above. This Final Permit (including the Final Permit and the Attachments) has been posted on the Department of Environmental Protection's website.

Click on the link displayed above to access the permit project documents and send a "reply" message verifying receipt of the document(s) provided in the link; this may be done by selecting "Reply" on the menu bar of your e-mail software, noting that you can view the documents, and then selecting "Send".

Permit project documents that are addressed in this email may require immediate action within a specified time frame. Please open and review the document(s) as soon as possible, and verify that they are accessible. Please advise this office of any changes to your e-mail address or that of the Engineer-of-Record.

The Southwest District is issuing electronic documents for permits, notices and other correspondence in lieu of hard copies through the United States Postal System, to provide greater service to the applicant and the engineering community. Access these documents by clicking on the link provided above, or search for other project documents using the "Air Permit Documents Search" website at <http://www.dep.state.fl.us/air/emission/apds/default.asp>.

If you should have any questions, please contact Brandy Flavors, the Permit Engineer at [Brandy.Flavors@dep.state.fl.us](mailto:Brandy.Flavors@dep.state.fl.us).

Sincerely,

*Patricia Prickett*

Patricia Prickett  
Senior Clerk  
FDEP - Air Program - SWD  
(813) 632-7600 Ext 102

Email: [Patricia.Prickett@dep.state.fl.us](mailto:Patricia.Prickett@dep.state.fl.us)

*Please Note: Florida has a very broad Public Records Law. Most written communications to or from State and Local Officials regarding State or Local business are public records available to the public and media upon request. Your email communications may therefore be subject to public disclosure.*

**Prickett, Patricia**

---

**From:** Microsoft Exchange  
**To:** 'jshow@cfl.rr.com'  
**Sent:** Wednesday, June 01, 2011 1:50 PM  
**Subject:** Relayed: RAINEY ASPHALT/WILDWOOD PLANT Number 1; 1190050-003-AC

**Delivery to these recipients or distribution lists is complete, but delivery notification was not sent by the destination:**

'jshow@cfl.rr.com'

Subject: RAINEY ASPHALT/WILDWOOD PLANT Number 1; 1190050-003-AC

---

Sent by Microsoft Exchange Server 2007

**Prickett, Patricia**

---

**From:** Sara Greivell [sara@grovescientific.com]  
**Sent:** Wednesday, June 01, 2011 1:54 PM  
**To:** Prickett, Patricia  
**Subject:** Re: RAINEY ASPHALT/WILDWOOD PLANT Number 1; 1190050-003-AC

Thank you

On Wed, Jun 1, 2011 at 1:49 PM, Prickett, Patricia <[Patricia.Prickett@dep.state.fl.us](mailto:Patricia.Prickett@dep.state.fl.us)> wrote:

Attention: Mr. Ike Rainey, Manager

Owner/Company Name: RAINEY ASPHALT LLC  
Facility Name: RAINEY ASPHALT/WILDWOOD PLANT Number1  
Project Number: 1190050-003-AC  
Permit Status: FINAL  
Permit Activity: CONSTRUCTION  
Facility County: SUMTER

Dear Mr. Rainey:

**IMPORTANT: We must receive verification, by email stating that you are able to access the attachment(s), and the LINK shown below. Your immediate reply will preclude subsequent e-mail transmissions to verify accessibility of the document(s).**

Click on the following link to access the permit project documents:

[http://ARM-PERMIT2K.dep.state.fl.us/adh/prod/pdf\\_permit\\_zip\\_files/1190050.003.AC.F\\_pdf.zip](http://ARM-PERMIT2K.dep.state.fl.us/adh/prod/pdf_permit_zip_files/1190050.003.AC.F_pdf.zip)

Attached is the official **Final Permit** for the project referenced above. This Final Permit (including the Final Permit and the Attachments) has been posted on the Department of Environmental Protection's website.

Click on the link displayed above to access the permit project documents and send a "reply" message verifying receipt of the document(s) provided in the link; this may be done by selecting "Reply" on the menu bar of your e-mail software, noting that you can view the documents, and then selecting "Send".

Permit project documents that are addressed in this email may require immediate action within a specified time frame. Please open and review the document(s) as soon as possible, and verify that they are accessible. Please advise this office of any changes to your e-mail address or that of the Engineer-of-Record.

The Southwest District is issuing electronic documents for permits, notices and other correspondence in lieu of hard copies through the United States Postal System, to provide greater service to the applicant and the engineering community. Access these documents by clicking on the link provided above, or search for other project documents using the "*Air Permit Documents Search*" website at

<http://www.dep.state.fl.us/air/emission/apds/default.asp>.

If you should have any questions, please contact Brandy Flavors, the Permit Engineer at [Brandy.Flavors@dep.state.fl.us](mailto:Brandy.Flavors@dep.state.fl.us).

Sincerely,

*Patricia Prickett*

Patricia Prickett

Senior Clerk

FDEP - Air Program - SWD

(813) 632-7600 Ext 102

Email: [Patricia.Prickett@dep.state.fl.us](mailto:Patricia.Prickett@dep.state.fl.us)

*Please Note: Florida has a very broad Public Records Law. Most written communications to or from State and Local Officials regarding State or Local business are public records available to the public and media upon request. Your email communications may therefore be subject to public disclosure.*

*The Department of Environmental Protection values your feedback as a customer. DEP Secretary Herschel T. Vinyard Jr. is committed to continuously assessing and improving the level and quality of services provided to you. Please take a few minutes to comment on the quality of service you received. Simply click on [this link to the DEP Customer Survey](#). Thank you in advance for completing the survey.*

--

Sara Greivell

Project Manager

Grove Scientific & Engineering

Phone: 407-298-2282 ext.108

Fax: 407-290-9038

[sara@grovescientific.com](mailto:sara@grovescientific.com)

**Prickett, Patricia**

---

**From:** Microsoft Exchange  
**To:** 'Sara Greivell'  
**Sent:** Wednesday, June 01, 2011 1:50 PM  
**Subject:** Relayed: RAINEY ASPHALT/WILDWOOD PLANT Number 1; 1190050-003-AC

**Delivery to these recipients or distribution lists is complete, but delivery notification was not sent by the destination:**

'Sara Greivell'

Subject: RAINEY ASPHALT/WILDWOOD PLANT Number 1; 1190050-003-AC

---

Sent by Microsoft Exchange Server 2007

**SWD INTERNAL PERMITTING MEMORANDUM**

TO: Cindy Zhang-Torres, P.E.  
Air Permitting Manager

FROM: Brandy Flavors   
Air Permitting Engineer

DATE: 06/01/2011

SUBJECT: Final Construction Permit No: 1190050-003-AC  
Rainey Asphalt, LLC

Day 90: 7/26/2011

The final permit for this project is attached for your approval and signature, which authorizes the addition of RAP crushing system. The work will be performed in Sumter County at 4477 CR 462 in Wildwood, Florida. The project results in a minor source air construction permit.

The Final Determination, attached to the Final Permit, summarizes the publication and comment process. There are no pending petitions for administrative hearings or extensions of time in which to file a petition for an administrative hearing. I recommend your approval of the attached final permit for this project.

## Prickett, Patricia

---

**From:** Matt Bass [mbass@raineyconstruction.com]  
**Sent:** Tuesday, May 10, 2011 4:02 PM  
**To:** Prickett, Patricia  
**Cc:** Sara Greivell; Mike Byrd  
**Subject:** RAINEY ASPHALT/WILDWOOD PLANT Number 1; 1190050-003-AC

The Written Notice of Intent to Issue Permit for Rainey Asphalt Plant Number 1;1190050-003-AC has been viewed and downloaded into our files from the email sent earlier. If you have any questions or if we need anything further please do not hesitate to contact us.

Thank you.

*Mathew Bass  
Rainey Construction Co.  
4477 East CR 462  
Wildwood, FL 34785  
Phone: (352) 748-0955  
Fax: (352) 748-4372*



**Prickett, Patricia**

---

**From:** Richelle Heath [rheath@raineyconstruction.com]  
**To:** Prickett, Patricia  
**Sent:** Tuesday, May 10, 2011 3:51 PM  
**Subject:** Read: RAINEY ASPHALT/WILDWOOD PLANT Number 1; 1190050-003-AC

Your message was read on Tuesday, May 10, 2011 3:51:07 PM (GMT-05:00) Eastern Time (US & Canada).

**Prickett, Patricia**

---

**From:** Sara Greivell [sara@grovescientific.com]  
**Sent:** Tuesday, May 10, 2011 1:12 PM  
**To:** Prickett, Patricia  
**Subject:** Re: RAINEY ASPHALT/WILDWOOD PLANT Number 1; 1190050-003-AC

Thank you

On Tue, May 10, 2011 at 1:09 PM, Prickett, Patricia <Patricia.Prickett@dep.state.fl.us> wrote:

Attention: Mr. Ike Rainey, Manager

Owner/Company Name: RAINEY ASPHALT LLC  
Facility Name: RAINEY ASPHALT/WILDWOOD PLANT Number1  
Project Number: 1190050-003-AC  
Permit Status: DRAFT  
Permit Activity: CONSTRUCTION  
Facility County: SUMTER

Dear Mr. Rainey:

**IMPORTANT: We MUST receive verification, by email, stating that you are able to access the attachments and the LINK shown below. Your immediate reply will preclude subsequent e-mail transmissions to verify accessibility of the document(s).**

Click on the following link to access the permit project documents:  
[http://ARM-PERMIT2K.dep.state.fl.us/adh/prod/pdf\\_permit\\_zip\\_files/1190050.003.AC.D\\_pdf.zip](http://ARM-PERMIT2K.dep.state.fl.us/adh/prod/pdf_permit_zip_files/1190050.003.AC.D_pdf.zip)

Attached is the official **Written Notice of Intent to Issue Air Permit** for the project referenced above. The Written Notice of Intent to Issue Air Permit (including the Draft Permit and the Attachments) has been posted on the Department of Environmental Protection's Southwest District website.

Click on the link displayed above to access the permit project documents and send a "reply" message verifying receipt of the document(s) provided in the link; this may be done by selecting "Reply" on the menu bar of your e-mail software, noting that you can view the documents, and then selecting "Send".

Permit project documents that are addressed in this email may require immediate action within a specified time frame. Please open and review the document(s) as soon as possible, and verify that they are accessible. Please advise this office of any changes to your e-mail address or that of the Engineer-of-Record.

The Southwest District is issuing electronic documents for permits, notices and other correspondence in lieu of hard copies through the United States Postal System, to provide greater service to the applicant and the engineering community. Access these documents by clicking on the link provided above, or search for other project documents using the "*Air Permit Documents Search*" website at <http://www.dep.state.fl.us/air/emission/apds/default.asp>.

For your convenience, I have also attached the Public Notice of Intent to Issue Air Permit in a word document.

If you should have any questions, please contact Brandy Flavors, the Permit Engineer at Brandy.Flavors@dep.state.fl.us.

Sincerely,

Patricia Prickett

Patricia Prickett

Senior Clerk

FDEP - Air Program - SWD

(813) 632-7600 Ext 102

Email: Patricia.Prickett@dep.state.fl.us

*Please Note: Florida has a very broad Public Records Law. Most written communications to or from State and Local Officials regarding State or Local business are public records available to the public and media upon request. Your email communications may therefore be subject to public disclosure.*

*The Department of Environmental Protection values your feedback as a customer. DEP Secretary Herschel T. Vinyard Jr. is committed to continuously assessing and improving the level and quality of services provided to you. Please take a few minutes to comment on the quality of service you received. Simply click on this link to the DEP Customer Survey. Thank you in advance for completing the survey.*

--

Sara Greivell  
Project Manager  
Grove Scientific & Engineering  
Phone: 407-298-2282 ext.108  
Fax: 407-290-9038  
sara@grovescientific.com

**Prickett, Patricia**

---

**From:** Microsoft Exchange  
**To:** 'Sara Greivell'  
**Sent:** Tuesday, May 10, 2011 1:10 PM  
**Subject:** Relayed: RAINEY ASPHALT/WILDWOOD PLANT Number 1; 1190050-003-AC

**Delivery to these recipients or distribution lists is complete, but delivery notification was not sent by the destination:**

'Sara Greivell'

**Subject:** RAINEY ASPHALT/WILDWOOD PLANT Number 1; 1190050-003-AC

---

Sent by Microsoft Exchange Server 2007

**Prickett, Patricia**

---

**From:** Microsoft Exchange  
**To:** 'jshow@cfl.rr.com'  
**Sent:** Tuesday, May 10, 2011 1:10 PM  
**Subject:** Relayed: RAINEY ASPHALT/WILDWOOD PLANT Number 1; 1190050-003-AC

**Delivery to these recipients or distribution lists is complete, but delivery notification was not sent by the destination:**

'jshow@cfl.rr.com'

Subject: RAINEY ASPHALT/WILDWOOD PLANT Number 1; 1190050-003-AC

---

Sent by Microsoft Exchange Server 2007

**Prickett, Patricia**

---

**From:** Prickett, Patricia  
**Sent:** Tuesday, May 10, 2011 1:10 PM  
**To:** 'irainey@raineyconstruction.com'  
**Cc:** 'Sara Greivell'; 'jshow@cfl.rr.com'; Flavors, Brandy; Zhang-Torres  
**Subject:** RAINEY ASPHALT/WILDWOOD PLANT Number 1; 1190050-003-AC  
**Attachments:** 1190050.003.ac.pub.Rainey.doc; 1190050.003.ac.d.int.rainey asphalt.pdf

**Importance:** High

<b>Tracking:</b>	<b>Recipient</b>	<b>Delivery</b>	<b>Read</b>
	'irainey@raineyconstruction.com'		
	'Sara Greivell'		
	'jshow@cfl.rr.com'		
	Flavors, Brandy	Delivered: 5/10/2011 1:10 PM	
	Zhang-Torres	Delivered: 5/10/2011 1:10 PM	Read: 5/10/2011 1:10 PM

Attention: Mr. Ike Rainey, Manager

Owner/Company Name: RAINEY ASPHALT LLC  
Facility Name: RAINEY ASPHALT/WILDWOOD PLANT Number1  
Project Number: 1190050-003-AC  
Permit Status: DRAFT  
Permit Activity: CONSTRUCTION  
Facility County: SUMTER

Dear Mr. Rainey:

**IMPORTANT: We MUST receive verification, by email, stating that you are able to access the attachments and the LINK shown below. Your immediate reply will preclude subsequent e-mail transmissions to verify accessibility of the document(s).**

Click on the following link to access the permit project documents:  
[http://ARM-PERMIT2K.dep.state.fl.us/adh/prod/pdf\\_permit\\_zip\\_files/1190050.003.AC.D\\_pdf.zip](http://ARM-PERMIT2K.dep.state.fl.us/adh/prod/pdf_permit_zip_files/1190050.003.AC.D_pdf.zip)

Attached is the official **Written Notice of Intent to Issue Air Permit** for the project referenced above. The Written Notice of Intent to Issue Air Permit (including the Draft Permit and the Attachments) has been posted on the Department of Environmental Protection's Southwest District website.

Click on the link displayed above to access the permit project documents and send a "reply" message verifying receipt of the document(s) provided in the link; this may be done by selecting "Reply" on the menu bar of your e-mail software, noting that you can view the documents, and then selecting "Send".

Permit project documents that are addressed in this email may require immediate action within a specified time frame. Please open and review the document(s) as soon as possible, and verify that they are accessible. Please advise this office of any changes to your e-mail address or that of the Engineer-of-Record.

The Southwest District is issuing electronic documents for permits, notices and other correspondence in lieu of hard copies through the United States Postal System, to provide greater service to the applicant and the engineering community. Access these documents by clicking on the link provided above, or search for other

project documents using the "Air Permit Documents Search" website at <http://www.dep.state.fl.us/air/emission/apds/default.asp>.

For your convenience, I have also attached the Public Notice of Intent to Issue Air Permit in a word document.

If you should have any questions, please contact Brandy Flavors, the Permit Engineer at [Brandy.Flavors@dep.state.fl.us](mailto:Brandy.Flavors@dep.state.fl.us).

Sincerely,

*Patricia Prickett*

Patricia Prickett  
Senior Clerk  
FDEP - Air Program - SWD  
(813) 632-7600 Ext 102

Email: [Patricia.Prickett@dep.state.fl.us](mailto:Patricia.Prickett@dep.state.fl.us)

*Please Note: Florida has a very broad Public Records Law. Most written communications to or from State and Local Officials regarding State or Local business are public records available to the public and media upon request. Your email communications may therefore be subject to public disclosure.*

## SWD INTERNAL PERMITTING MEMORANDUM

TO: Cindy Zhang-Torres, P.E.  
Air Permitting Manager

FROM: Brandy Flavors   
Air Permitting Engineer

DATE: 05/09/2011

SUBJECT: Draft Permit No: 1190050-003-AC  
Facility Name: Rainey Asphalt, LLC

Day 90: 07/06/2011

This is the draft air construction permit, which authorizes the addition of a RAP Crushing System to the existing drum mix asphalt plant. The facility is a synthetic non-Title V source for particulate matter with an aerodynamic diameter less than or equal to a nominal 10 micrometers (PM<sub>10</sub>), sulfur dioxide (SO<sub>2</sub>), carbon monoxide (CO) and hazardous air pollutants (HAPs). The drum mix asphalt concrete plant is regulated under New Source Performance Standards (NSPS) - 40 CFR 60, Subpart I - Standards of Performance for Hot Mix Asphalt Facilities and the general provisions of 40 CFR 60, Subpart A. This facility is also regulated under Rule 62-210.300(3)(c)2., F.A.C., conditional exemptions from Title V permitting.

An email was sent to Sara Greivell of Grove Scientific & Engineering on April 4, 2011 requesting information regarding emission points and fuel usage by the diesel engine. Continuing correspondence took place between Jim McDonald, Sara Greivell, and myself from April 4, 2011 to April 7, 2011. On April 7, 2011 Sara emailed a list of emission points that appeared to be reasonable and was included in the permit. On May 4, 2011 I sent an email to facility requesting they confirm the proposed emission points. Mike Byrd of Rainey Asphalt responded on May 5, 2011 with a list of emission points and a flow diagram that have been incorporated into the draft permit. Also Mike estimated that the oversized material returned to the hopper to be approximately 20% of the original rate.

There is no open enforcement at the facility.

I recommend the issuance of this draft construction permit.



## Flavors, Brandy

---

**From:** Mike Byrd [mbyrd@raineyconstruction.com]  
**Sent:** Wednesday, May 04, 2011 2:46 PM  
**To:** Flavors, Brandy  
**Cc:** Sara Greivell  
**Subject:** RE: 1190050-003-AC Rainey Asphalt RAP crushing system emission points  
**Attachments:** Crusher 5.jpg; Crusher4.jpg

I did find 2 more pictures that show the oversize return to hopper belt.

The belt seen in picture is used when you are taking out fines from primary hopper we will not be discharging from this belt but if they need to be included then there will be 2 more drop points one from hopper to belt from belt to ground.

Hope this helps.

Thanks, Mike Byrd

*5/6 @ 10:08 AM @ 15-20 % 3/8 - return on side.*

---

**From:** Mike Byrd  
**Sent:** Wednesday, May 04, 2011 2:27 PM  
**To:** 'Flavors, Brandy'  
**Cc:** 'Sara Greivell'  
**Subject:** RE: 1190050-003-AC Rainey Asphalt RAP crushing system emission points

I cannot find a picture that shows the other side very well I attached one there is a conveyor attached that brings the oversize material back to the hopper this is a closed circuit system.

1.The material is put into hopper.

2.Material goes into crusher.

3.Material exits bottom of crusher.

4.material lands on belt.

5.material drops on to two deck screen built into machine.

6. Material of proper size goes onto discharge belt.

7. Oversize material drops onto short belt .

8. Material drops onto belt that returns material to hopper to be further resized.

9.All resized material and finished material are discharged on the same belt.

10.Material from discharge belt drops on radial stacker belt.

11 All finished material drops from radial stacker to ground stockpile.

There is a side belt that is used for a magnetic material discharge which discharges any tramp metal pulled from finished product.

The side discharge belt that is used for fines will not be used in our application as we want all the finished product to exit on material discharge belt.

I am attaching another picture that shows a different angle and the material discharge to the stacking conveyor any more questions I will gladly try to answer.

Thank You for Your help and patience, Mike Byrd

I hope this helps.

(Attached picture is in paint )

---

**From:** Flavors, Brandy [<mailto:Brandy.Flavors@dep.state.fl.us>]  
**Sent:** Wednesday, May 04, 2011 1:12 PM  
**To:** 'Sara Greivell'; Mike Byrd  
**Cc:** [j\\_sshow@bellsouth.net](mailto:j_sshow@bellsouth.net)  
**Subject:** 1190050-003-AC Rainey Asphalt RAP crushing system emission points

See below the points proposed to be included in the permit.

Emission Point No.	Brief Description
1	Front End Loader to Feeder Hopper
2	Feed Hopper to Crusher
3	Crusher
4	Crusher Discharge to Conveyor Belt
5	Conveyor Belt Discharge to Screen
6	Screen
7	Screen to Oversize Conveyor
8	Oversize Conveyor to Crusher
9	Screen Transfer onto Conveyor Belt
10	Conveyor Belt Transfer to Stacker Belt
11	Discharge Stacker Belt to Stockpile

Also please see below the diagram provided for the RAP crushing system to be brought on-site.

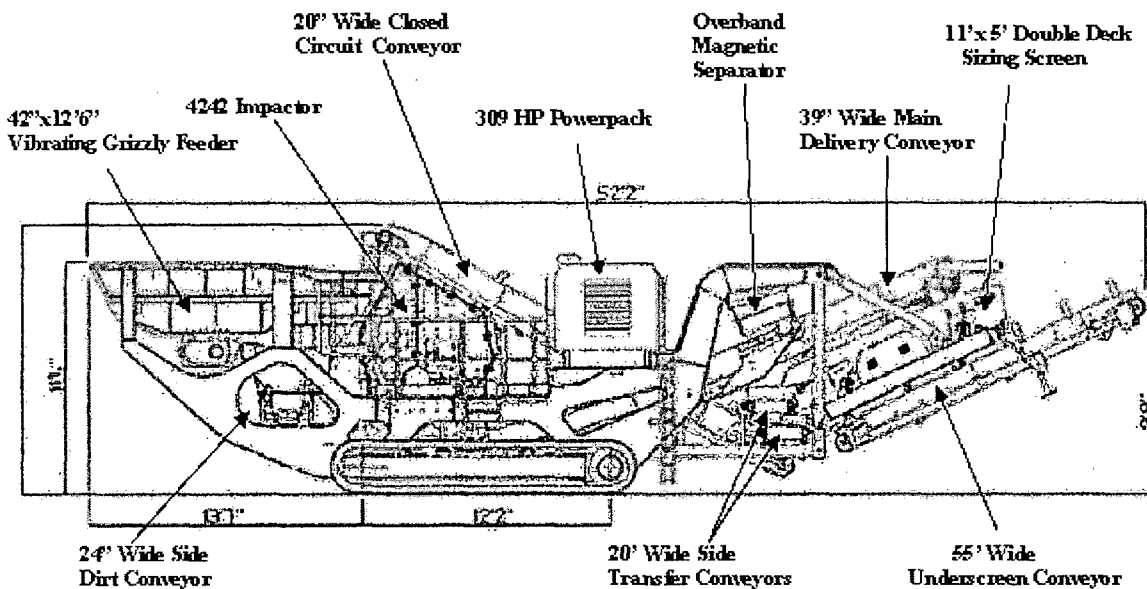

It appears from this diagram that the emission points requested and listed above will not be adequate for this diagram of the 4242sr Trakpaktor.

Please explain where the 24" Wide Dirt Conveyor and 20" Wide Side Transfer Conveyers (which there appears to be (2)) are included in the list of emissions. The Double Deck Screen eludes that there will be 3 belts leaving the screen: Are they accounted for? Also, the screen is some distance from the crusher, which conveyor return the RAP to the crusher as listed on this diagram?

If you feel that the emission points listed above are adequate, please respond advising they are acceptable. Although it appears additional emission points will be required to used the unit proposed in the application.

*The Department of Environmental Protection values your feedback as a customer. DEP Secretary Herschel T. Vinyard Jr. is committed to continuously assessing and improving the level and quality of services provided to you. Please take a few*

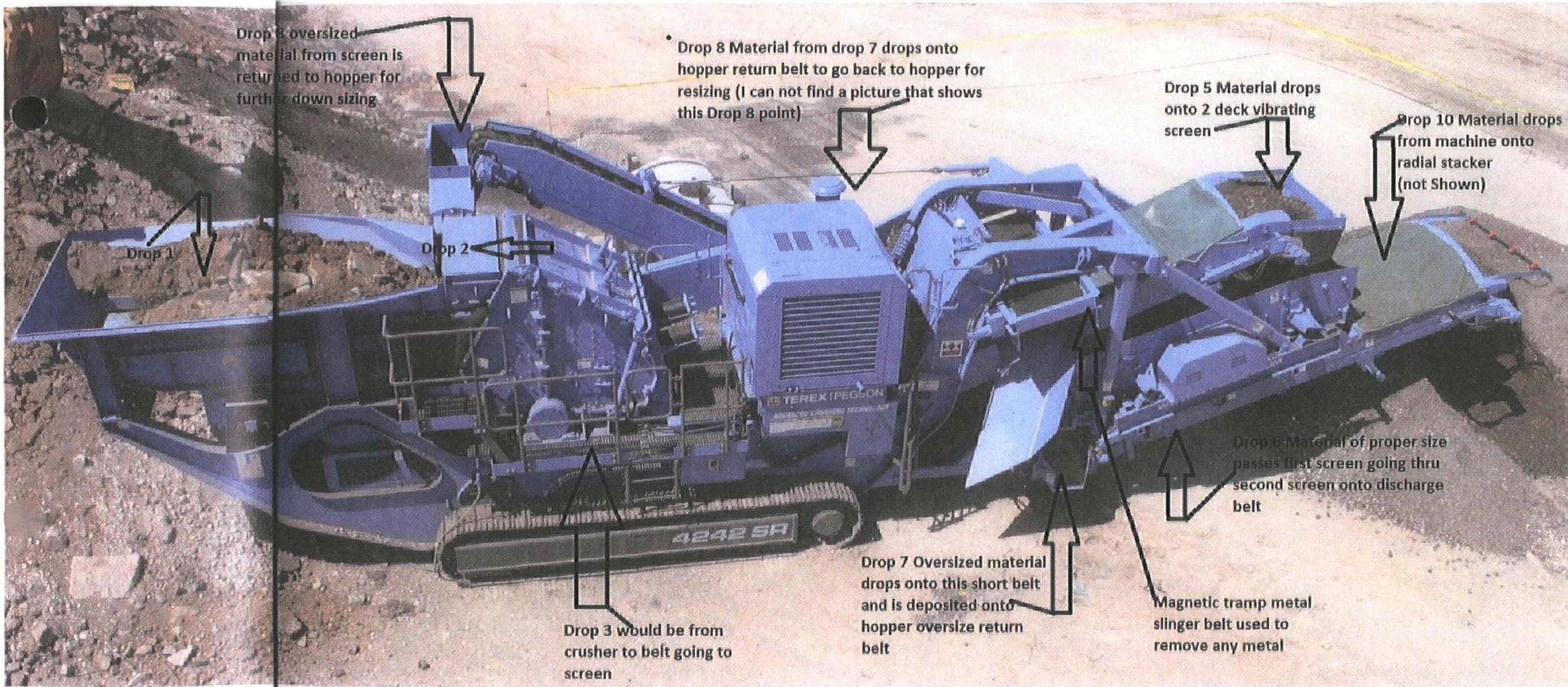

Drop 3 oversized material from screen is returned to hopper for further down sizing

Drop 8 Material from drop 7 drops onto hopper return belt to go back to hopper for resizing (I can not find a picture that shows this Drop 8 point)

Drop 5 Material drops onto 2 deck vibrating screen

Drop 10 Material drops from machine onto radial stacker (not Shown)

Drop 1

Drop 2

Drop 6 Material of proper size passes first screen going thru second screen onto discharge belt

Drop 3 would be from crusher to belt going to screen

Drop 7 Oversized material drops onto this short belt and is deposited onto hopper oversize return belt

Magnetic tramp metal slinger belt used to remove any metal





Attachment to April 7,

**RAINEY ASPHALT REVISED CRUSHER EMISSION POINTS & EMISSION CALCULATIONS**

2011 email  
from Sara  
Greivell

**Potential Emissions**

The potential emissions are calculated based on the maximum capacity of 250 tons per hour and annual throughput of 400,000 tons per year.

PM Emissions from Crushing Operations

The emissions from crushing operations are calculated using AP-42 Table 11.19.2-2 Emission Factors for Crushed Stone Processing Operations (lb/Ton). For lack of any other available emission factors, Tertiary Crushing (controlled) was used for the crusher. Screening (controlled) and Conveyor Transfer Point (controlled) are used for the emissions from the screen and transfer belts. The "controlled" emission factors are used because the crusher is equipped with dust suppression spray. Below is a table that summarized the emission points:

Emission Point Number	Description of Emission Points
1	Material from storage pile transferred by front-end loader to feeder hopper
2	Feed hopper to crusher
3	Crusher
4	Crusher discharge to conveyor belt
5	Conveyor belt discharge to screen
6	Screen
7	Conveyor from screen back to crusher
8	Screen transfer onto conveyor belt
9	Conveyor belt transfer to stacker belt
10	Discharge stacker belt to stockpile

Conveyor  
to  
crusher  
to  
Crusher.

The emissions are calculated as follows:

Crushing:

$$\text{PM} - (400,000 \text{ tons per year})(0.0012 \text{ lbs/ton}) / (2000 \text{ lbs/ton}) = \underline{0.24 \text{ tons per year PM}}$$

$$\text{PM}_{10} - (400,000 \text{ tons per year})(0.00054 \text{ lbs/ton}) / (2000 \text{ lbs/ton}) = \underline{0.108 \text{ tons per year PM}_{10}}$$

Screening:

$$\text{PM} - (400,000 \text{ tons per year})(0.0022 \text{ lbs/ton}) / (2000 \text{ lbs/ton}) = \underline{0.44 \text{ tons per year PM}}$$

$$\text{PM}_{10} - (400,000 \text{ tons per year})(0.00074 \text{ lbs/ton}) / (2000 \text{ lbs/ton}) = \underline{0.148 \text{ tons per year PM}_{10}}$$

Conveyor Transfer Points:

$$\text{PM} - (400,000 \text{ tons per year})(0.00014 \text{ lbs/ton})/(2000 \text{ lbs/ton}) = 0.028 \text{ tons per year PM}$$

$$(0.028 \text{ tons per year PM})(8 \text{ transfer points}) = \underline{0.224 \text{ tons per year PM}}$$

$$\text{PM}_{10} - (400,000 \text{ tons per year})(0.000046 \text{ lbs/ton})/(2000 \text{ lbs/ton}) = 0.0092 \text{ tons per year PM}_{10}$$

$$(0.0092 \text{ tons per year PM})(8 \text{ transfer points}) = \underline{0.0736 \text{ tons per year PM}_{10}}$$

(9 pts)  
Summary Table of PM Emissions from Crushing

Source	PM-Total	PM10
Crushing	0.24	0.108
Screening	0.44	0.148
Conveyor Transfer Points (8)	0.224	0.0736
<b>TOTAL</b>	<b>0.904</b>	<b>0.330</b>

Summary Table of Potential Emissions from Crushing Operation

	NO <sub>x</sub>	CO	SO <sub>x</sub>	PM	PM10	VOC
Crushing				0.90	0.33	
Engine	7.66	1.65	0.51	0.54	0.54	0.60
<b>TOTALS</b>	<b>7.66</b>	<b>1.65</b>	<b>0.51</b>	<b>1.44</b>	<b>0.87</b>	<b>0.60</b>

crushing 0.24 tons per year  
 screen 0.44 tons per year  
 + 8 transfer 0.224 tons per year  
 +  $(400,000 \text{ tpy})(0.20 \text{ y})(0.00014)/(2000) = 0.0056 \text{ tons/year}$   
 total emissions = 0.91 tpy

## Flavors, Brandy

---

**From:** Sara Greivell [sara@grovescientific.com]  
**Sent:** Thursday, April 07, 2011 8:56 AM  
**To:** McDonald, Jim  
**Cc:** Flavors, Brandy  
**Subject:** Re: Emission Points  
**Attachments:** RAINEY ASPHALT REVISED CRUSHER EMISSION POINTS 04-11.pdf

Brandy,

Please use this updated list of emission points and emissions calculations for the Rainey Asphalt permit application.

Thank you,  
Sara

On Wed, Apr 6, 2011 at 2:20 PM, Sara Greivell <sara@grovescientific.com> wrote:  
Hi Jim and Brandy,

I spoke with my contact at Rainey and have attached a revised list of emissions points along with revised calculations.

Let me know if you have any questions.

Thank you,  
Sara

On Tue, Apr 5, 2011 at 11:32 AM, McDonald, Jim <Jim.McDonald@dep.state.fl.us> wrote:

Sara, Brandy needs info on emission points and associated emission calculations for each material transfer/crushing/screening activity.

EXAMPLE of how we write the permit condition (this one does not have a screen).

A.5. Visible Emissions Limitations: Each emission point shown below shall comply with the following maximum visible emission limitations.

<b>Emission Point No.</b>	<b>Brief Description</b>	<b>Max. VE Limit</b>	<b>Max. VE Limit</b>	<b>Max. VE Limit</b>
---------------------------	--------------------------	----------------------	----------------------	----------------------



		(% Opacity) <sup>1</sup>	(% Opacity) <sup>2</sup>	(% Opacity) <sup>3</sup>
1	Material from outdoor stockpiles transferred by front-end loader(s) to Grizzly Feeder (Hopper)	<20	<20	<20
2	Grizzly Feeder to Crusher	<20	15	12
3	Crusher	<20	15	12
4	Crusher to Discharge Conveyor Belt	<20	15	12
5	Discharge Conveyor Belt to Stockpile	<20	<20	<20
6	Grizzly Feeder to Muck Conveyor Belt	<20	10	7
7	Muck Conveyor Belt to Stockpile	<20	<20	<20

<sup>1</sup> For crushers and affected pieces of equipment that are only subject to Rule 62-296.320(4)(b), F.A.C. and not subject to 40 CFR 60, Subpart OOO. Crushers and other affected pieces of equipment (i.e., screen, conveyor belt, etc.) are not subject to 40 CFR 60, Subpart OOO, if that crusher or piece of equipment was constructed, modified, or reconstructed prior to or on August 31, 1983.

<sup>2</sup> For crushers and affected pieces of equipment that commenced construction, modification or reconstruction after 8/31/1983, but before 4/22/2008.

<sup>3</sup> For crushers and affected pieces of equipment that commenced construction, modification or reconstruction on or after 4/22/2008.

Emission Point Nos. with a maximum opacity limit of <20% do not require regular scheduled VE compliance testing, since the applicable visible emission limitation is a facility-wide limitation and there is no applicable allowable mass emission limitation. Emission Point Nos. 2 and 3 are at the same location and require only one VE test when both activities are occurring.

[Rules 62-210.200 ("Potential to Emit") and 62-296.320(4)(b), F.A.C.; 40 CFR 60.672(b) and (d)]

Jim McDonald, Engineering Specialist IV  
Florida Department of Environmental Protection  
Southwest District - Air Resource Management  
13051 N. Telecom Parkway  
Temple Terrace, FL 33637-0926  
813-632-7600, extension 106  
Fax 813-632-7668  
email: [Jim.McDonald@dep.state.fl.us](mailto:Jim.McDonald@dep.state.fl.us)

*"This staff assessment is preliminary and is designed to assist in the review of the information provided prior to final agency action. The comments provided herein are not the final position of the department and may be subject to revision pursuant to additional information and further review".*

*The Department of Environmental Protection values your feedback as a customer. DEP Secretary Herschel T. Vinyard Jr. is committed to continuously assessing and improving the level and quality of services provided to you. Please take a few minutes to comment on the quality of service you received. Simply click on [this link to the DEP Customer Survey](#). Thank you in advance for completing the survey.*

--  
Sara Greivell  
Project Manager  
Grove Scientific & Engineering  
Phone: 407-298-2282 ext.108  
Fax: 407-290-9038  
[sara@grovescientific.com](mailto:sara@grovescientific.com)

--  
Sara Greivell  
Project Manager

Grove Scientific & Engineering  
Phone: 407-298-2282 ext.108  
Fax: 407-290-9038  
[sara@grovescientific.com](mailto:sara@grovescientific.com)

## Flavors, Brandy

---

**From:** Sara Greivell [sara@grovescientific.com]  
**Sent:** Monday, April 04, 2011 1:37 PM  
**To:** Flavors, Brandy  
**Cc:** mbyrd@raineyconstruction.com  
**Subject:** Re: Rainey Asphalt, LLC Construction Permit No. 1190050-003-AC

Brandy,

1. The drop points from the crusher that is included in the application will have (1) crushing, (2) screening, (3) drop point from crusher to conveyor, (4) drop point from the 1st conveyor to 2nd conveyor. The reason 4 transfer points (other than crusher & screening) were used to calculate emissions in a "worst case scenario" as the facility wants the flexibility to either rent this crusher (the one included in the application) or bring in an outside contractor. At this time an outside contractor has not been selected yet so 4 transfer points were used to make sure the potential emission represent the worst case.

2. The engine on the crusher that this facility plans to rent has a 309 HP engine. We agree that this engine will meet the exemption criteria and that all units claiming exemption at the facility shall not collectively burn more than 32,000 gallons of diesel fuel.

Please let me know if you have any further questions.

Thank you,  
Sara

On Mon, Apr 4, 2011 at 9:55 AM, Flavors, Brandy <[Brandy.Flavors@dep.state.fl.us](mailto:Brandy.Flavors@dep.state.fl.us)> wrote:

Sara,

Please provide additional information for the above mentioned construction permit application.

1. The supplemental information uses crushing, screening and (4) conveyer transfer points to calculate emissions. Please provide a brief description of each emission point as it would be listed in the permit.
2. The crusher will be powered by a diesel engine. It appears that the proposed is a 309 HP engine, is that correct? In order for the diesel engine to be exempt all units claiming exemption at the facility shall not collectively burn more than 32,000 gallons of diesel fuel. Do you agree to this condition?

Please provide the requested information by noon Wednesday April 6, 2011.

## Flavors, Brandy

---

**From:** Flavors, Brandy  
**Sent:** Monday, April 04, 2011 9:55 AM  
**To:** 'sara@grovescientific.com'; 'mbyrd@raineyconstruction.com'  
**Subject:** Rainey Asphalt, LLC Construction Permit No. 1190050-003-AC

Sara,

Please provide additional information for the above mentioned construction permit application.

1. The supplemental information uses crushing, screening and (4) conveyer transfer points to calculate emissions. Please provide a brief description of each emission point as it would be listed in the permit.
2. The crusher will be powered by a diesel engine. It appears that the proposed is a 309 HP engine, is that correct? In order for the diesel engine to be exempt all units claiming exemption at the facility shall not collectively burn more than 32,000 gallons of diesel fuel. Do you agree to this condition?

Please provide the requested information by noon Wednesday April 6, 2011.

## Flavors, Brandy

---

**From:** Schroeder, Bill  
**Sent:** Thursday, March 24, 2011 8:05 AM  
**To:** Flavors, Brandy  
**Subject:** FW: Rainey Asphalt LLC - AC to add a RAP crusher - Project No.:1190050-003-AC

Brandy, I have no comments on the crusher.

Bill

---

**From:** Prickett, Patricia  
**Sent:** Wednesday, March 23, 2011 1:46 PM  
**To:** Schroeder, Bill  
**Cc:** Flavors, Brandy  
**Subject:** Rainey Asphalt LLC - AC to add a RAP crusher - Project No.:1190050-003-AC

The permitting section has received an application from Rainey Asphalt LLC. The application is for adding a RAP Crusher. The Project No. is 1190050-003-AC. If you have any comments or concerns, please contact the permit engineer Brandy Flavors.

Thank you,

Patricia Prickett

Patricia Prickett  
Senior Clerk  
FDEP - Air Program - SWD  
(813) 632-7600 Ext 102

Email: [Patricia.Prickett@dep.state.fl.us](mailto:Patricia.Prickett@dep.state.fl.us)

*Please Note: Florida has a very broad Public Records Law. Most written communications to or from State and Local Officials regarding State or Local business are public records available to the public and media upon request. Your email communications may therefore be subject to public disclosure.*

**Prickett, Patricia**

---

**From:** Prickett, Patricia  
**Sent:** Wednesday, March 23, 2011 1:46 PM  
**To:** Schroeder, Bill  
**Cc:** Flavors, Brandy  
**Subject:** Rainey Asphalt LLC - AC to add a RAP crusher - Project No.:1190050-003-AC

The permitting section has received an application from Rainey Asphalt LLC. The application is for adding a RAP Crusher. The Project No. is 1190050-003-AC. If you have any comments or concerns, please contact the permit engineer Brandy Flavors.

Thank you,

*Patricia Prickett*

Patricia Prickett  
Senior Clerk  
FDEP - Air Program - SWD  
(813) 632-7600 Ext 102

Email: [Patricia.Prickett@dep.state.fl.us](mailto:Patricia.Prickett@dep.state.fl.us)

*Please Note: Florida has a very broad Public Records Law. Most written communications to or from State and Local Officials regarding State or Local business are public records available to the public and media upon request. Your email communications may therefore be subject to public disclosure.*

March 21, 2011

Ms. Cindy Zhang-Torres, P.E.  
Air Permitting Supervisor  
FDEP, Southwest District Office  
13051 North Telecom Parkway  
Temple Terrace, Florida 33637

**Re: Rainey Asphalt, LLC  
Air Construction Permit Application  
Add Crushing Operation  
EPSAP Application # 2892-1  
Permit No.: 1190050-002-AO**

Dear Ms. Zang-Torres:

Enclosed are the P.E. signature pages, the fee calculation page and attachments for the above referenced facility along with the application of \$1000.

If you have any questions or need any additional information, please e-mail me at [sara@grovescientific.com](mailto:sara@grovescientific.com) or call me at (407) 298-2282.

Respectfully,

GROVE SCIENTIFIC & ENGINEERING COMPANY

  
Sara Greivell  
Environmental Scientist

CC: Mike Byrd - Rainey Asphalt, LLC

Dept. of Environmental  
Protection  
MAR 23 2011  
Southwest District