

**GLOBAL TIRE RECYCLING  
OF SUMTER COUNTY, INC.  
AC/AO PERMIT APPLICATION  
Facility ID # 1190028**

Wildwood, Florida

SES Project No. 07P189

**Dept. of Environmental  
Protection**

**APR 17 2007**

**Southwest District**

Prepared By:

**SOUTHERN ENVIRONMENTAL SCIENCES, INC.  
1204 North Wheeler Street  
Plant City, Florida 33563**

Prepared For:

**GLOBAL TIRE RECYCLING  
OF SUMTER COUNTY, INC.  
1201 Industrial Drive  
Wildwood, Florida 34785**

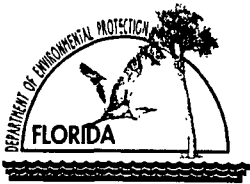

# Department of Environmental Protection

## Division of Air Resources Management

### APPLICATION FOR AIR PERMIT - NON-TITLE V SOURCE

See Instructions for Form No. 62-210.900(3)

#### I. APPLICATION INFORMATION

##### Identification of Facility

7. Facility Owner/Company Name: <b>GLOBAL TIRE RECYCLING OF SUMTER COUNTY, INC.</b>	
2. Site Name: <b>WILDWOOD FACILITY</b>	
3. Facility Identification Number: <b>1190028</b> [ ] Unknown	
4. Facility Location: Street Address or Other Locator: <b>1201 INDUSTRIAL DRIVE</b> City: <b>WILDWOOD</b> County: <b>SUMTER</b> Zip Code: <b>34785</b>	
5. Relocatable Facility? [ ] Yes [X] No	6. Existing Permitted Facility? [X] Yes [ ] No

##### Application Contact

Name and Title of Application Contact: <b>MARK J. BAILEY, VICE PRESIDENT, PLANT OPERATIONS</b>	
2. Application Contact Mailing Address: Organization/Firm: <b>GLOBAL TIRE RECYCLING OF SUMTER COUNTY, INC.</b> Street Address: <b>1201 INDUSTRIAL DRIVE</b> City: <b>WILDWOOD</b> State: <b>FL</b> Zip Code: <b>34785</b>	
3. Application Contact Telephone Numbers: Telephone: <b>(352) 330-2213</b> Fax: <b>(352) 330-2214</b>	

##### Application Processing Information (DEP Use)

1. Date of Receipt of Application:	<b>4/17/2007</b>
2. Permit Number:	<b>1190028-005-AC + 1190028-006-A0</b>

**Purpose of Application**

**Air Operation Permit Application**

This Application for Air Permit is submitted to obtain: (Check one)

Initial non-Title V air operation permit for one or more existing, but previously unpermitted, emissions units.

Initial non-Title V air operation permit for one or more newly constructed or modified emissions units.

Current construction permit number: \_\_\_\_\_

Non-Title V air operation permit revision to address one or more newly constructed or modified emissions units.

Current construction permit number: \_\_\_\_\_

Operation permit number to be revised: \_\_\_\_\_

Initial non-Title V air operation permit under Rule 62-210.300(2)(b), F.A.C., for an existing facility seeking classification as a synthetic non-Title V source.

Current operation/construction permit number(s):  
\_\_\_\_\_

Non-Title V air operation permit revision for a synthetic non-Title V source. Give reason for revision; e.g., to address one or more newly constructed or modified emissions units.

Operation permit number to be revised: \_\_\_\_\_

Reason for revision: \_\_\_\_\_

**Air Construction Permit Application**

This Application for Air Permit is submitted to obtain: (Check one)

Air construction permit to construct or modify one or more emissions units.

Air construction permit to make federally enforceable an assumed restriction on the potential emissions of one or more existing, permitted emissions units.

Air construction permit for one or more existing, but unpermitted, emissions units.

**Owner/Authorized Representative**

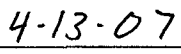
7. Name and Title of Owner/Authorized Representative: <b>MARK J. BAILEY, VICE PRESIDENT, PLANT OPERATIONS</b>	
2. Owner/Authorized Representative Mailing Address: Organization/Firm: <b>GLOBAL TIRE RECYCLING OF SUMTER COUNTY, INC.</b> Street Address: <b>1201 INDUSTRIAL DRIVE</b> City: <b>WILDWOOD</b> State: <b>FL</b> Zip Code: <b>34785</b>	
3. Owner/Authorized Representative Telephone Numbers: Telephone: <b>(352) 330-2213</b> Fax: <b>(352) 330-2214</b>	
4. Owner/Authorized Representative Statement:  <i>I, the undersigned, am the owner or authorized representative* of the facility addressed in this application. I hereby certify, based on information and belief formed after reasonable inquiry, that the statements made in this application are true, accurate and complete and that, to the best of my knowledge, any estimates of emissions reported in this application are based upon reasonable techniques for calculating emissions. The air pollutant emissions units and air pollution control equipment described in this application will be operated and maintained so as to comply with all applicable standards for control of air pollutant emissions found in the statutes of the State of Florida and rules of the Department of Environmental Protection and revisions thereof. I understand that a permit, if granted by the Department, cannot be transferred without authorization from the Department, and I will promptly notify the Department upon sale or legal transfer of any permitted emissions unit.</i>   _____ Signature   _____ Date	

\* Attach letter of authorization if not currently on file.

**Professional Engineer Certification**

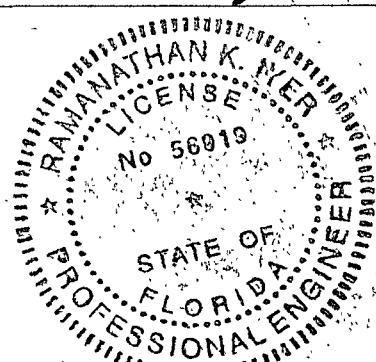
1. Professional Engineer Name: <b>RAMA IYER</b> Registration Number: <b>56919</b>
2. Professional Engineer Mailing Address: Organization/Firm: <b>SOUTHERN ENVIRONMENTAL SCIENCES, INC.</b> Street Address: <b>1204 NORTH WHEELER STREET</b> City: <b>PLANT CITY</b> State: <b>FL</b> Zip Code: <b>33563</b>
3. Professional Engineer Telephone Numbers: Telephone: <b>(813) 752-5014</b> Fax: <b>(813) 752-2475</b>
4. Professional Engineer Statement:  <i>I, the undersigned, hereby certify, except as particularly noted herein*, that:</i>  <i>(1) To the best of my knowledge, there is reasonable assurance that the air pollutant emissions unit(s) and the air pollution control equipment described in this Application for Air Permit, when properly operated and maintained, will comply with all applicable standards for control of air pollutant emissions found in the Florida Statutes and rules of the Department of Environmental Protection; and</i>  <i>(2) To the best of my knowledge, any emission estimates reported or relied on in this application are true, accurate, and complete and are either based upon reasonable techniques available for calculating emissions or, for emission estimates of hazardous air pollutants not regulated for an emissions unit addressed in this application, based solely upon the materials, information and calculations submitted with this application.</i>  <i>If the purpose of this application is to obtain an air construction permit for one or more proposed new or modified emissions units (check here [ X ], if so), I further certify that the engineering features of each such emissions unit described in this application have been designed or examined by me or individuals under my direct supervision and found to be in conformity with sound engineering principles applicable to the control of emissions of the air pollutants characterized in this application.</i>  <i>If the purpose of this application is to obtain an initial air operation permit or operation permit revision for one or more newly constructed or modified emissions units (check here [X], if so), I further certify that, with the exception of any changes detailed as part of this application, each such emissions unit has been constructed or modified in substantial accordance with the information given in the corresponding application for air construction permit and with all provisions contained in such permit.</i>  Signature: <u><i>Rama Iyer</i></u> Date: <u><i>April 16, 2007</i></u>   (seal) GLOBAL TRIE RECYCING OF SUMTER COUNTY, INC.

\* Attach any exception to certification statement.

Scope of Application

<b>Emissions Unit ID</b>	<b>Description of Emissions Unit</b>	<b>Permit Type</b>	<b>Processing Fee</b>
001	CRUMB RUBBER MANUFACTURING PLANT	AC1F	250.00
001	CRUMB RUBBER MANUFACTURING PLANT	AO2B	1000.00

**Application Processing Fee**

Check one: [  ] Attached - Amount: \$ 1250.00 [  ] Not Applicable

**Construction/Modification Information**

1. Description of Proposed Project or Alterations:

**This facility consists of waste tire receiving, storage and staging areas; a rotary shear type tire shredder; two cracker mills in series with air separation screens; three fine grind mills in parallel with air separation screens; intermediate and final product storage bins; and final product bagging and bulk loadout bins.**

**In the process, waste tires are passed through a shredder that reduces the tires to 2-4 inch chips. The chips are then passed through two cracker mills that further reduces the size of the chips and separates the fiber, metal tread and cord material from the rubber. The metal is removed with magnets and the fiber and any other foreign material is removed on air aspirated screening tables and gravity tables. The separation process results in debris free rubber 1/8 to 3/8 inch in diameter. Oversized rubber is fed back into the cracker mills. Fine grinding mills then reduce the rubber to mesh-sized crumb rubber product. Each fine grind mill is followed by and air aspirated screening operation. Oversize material is feed back to the fine grind mills. The final product is then conveyed via a screw elevator to a loadout hopper for bagging or bulk shipment to customers.**

**Particulate emissions from the air aspirated screening processes are vented through a common baghouse before being discharged to the atmosphere.**

2. Projected or Actual Date of Commencement of Construction: **NA**

3. Projected Date of Completion of Construction: **NA**

**Application Comment**

**Permittee inadvertently allowed AO permit to expire for this facility and is applying simultaneously for an AC/AO permit.**

## II. FACILITY INFORMATION

### A. GENERAL FACILITY INFORMATION

#### Facility Location and Type

1. Facility UTM Coordinates: Zone: <b>17</b> East (km): <b>397.53</b> North (km): <b>3192.08</b>			
2. Facility Latitude/Longitude: Latitude (DD/MM/SS): <b>28/51/14</b> Longitude (DD/MM/SS): <b>82/03/02</b>			
3. Governmental Facility Code: <b>0</b>	4. Facility Status Code: <b>A</b>	5. Facility Major Group SIC Code: <b>30</b>	6. Facility SIC(s): <b>3011</b>
7. Facility Comment (limit to 500 characters):			

#### Facility Contact

7. Name and Title of Facility Contact: <b>MARK J. BAILEY, VICE PRESIDENT, PLANT OPERATIONS</b>			
2. Facility Contact Mailing Address: <b>Organization/Firm: GLOBAL TIRE RECYCLING OF SUMTER COUNTY, MINC.</b> Street Address: <b>1201 INDUSTRIAL DRIVE</b> City: <b>WILDWOOD</b> State: <b>FL</b> Zip Code: <b>34785</b>			
3. Facility Contact Telephone Numbers: Telephone: <b>(352) 330-2213</b> Fax: <b>(352) 330-2214</b>			



**Facility Regulatory Classifications**

**Check all that apply:**

1. <input type="checkbox"/> Small Business Stationary Source?	<input checked="" type="checkbox"/> Unknown
2. <input type="checkbox"/> Synthetic Non-Title V Source?	
3. <input type="checkbox"/> Synthetic Minor Source of Pollutants Other than HAPs?	
4. <input type="checkbox"/> Synthetic Minor Source of HAPs?	
5. <input type="checkbox"/> One or More Emissions Units Subject to NSPS?	
6. <input type="checkbox"/> One or More Emission Units Subject to NESHAP Recordkeeping or Reporting?	
7. Facility Regulatory Classifications Comment (limit to 200 characters):	
<p><b>This facility is a natural minor source of both haps and criteria pollutants</b></p>	

**Rule Applicability Analysis**

**General Pollutant Emissions Limiting Standards, 17-296.320, FAC  
Exceptions and Approval of Alternate Procedures and Requirements 17-297.620, FAC. Five percent VE on baghouse exhaust in lieu of stack testing.**

## B. FACILITY POLLUTANTS

### List of Pollutants Emitted

1. Pollutant Emitted	2. Pollutant Classif.	3. Requested Emissions Cap		4. Basis for Emissions Cap	5. Pollutant Comment
		lb/hour	tons/year		
PM	B				



**III. EMISSIONS UNIT INFORMATION**

A separate Emissions Unit Information Section (including subsections A through G as required) must be completed for each emissions unit addressed in this Application for Air Permit. If submitting the application form in hard copy, indicate, in the space provided at the top of each page, the number of this Emissions Unit Information Section and the total number of Emissions Unit Information Sections submitted as part of this application.

**A. GENERAL EMISSIONS UNIT INFORMATION**

**Emissions Unit Description and Status**

<p>1. Type of Emissions Unit Addressed in This Section: (Check one)</p> <p><input checked="" type="checkbox"/> This Emissions Unit Information Section addresses, as a single emissions unit, a single process or production unit, or activity, which produces one or more air pollutants and which has at least one definable emission point (stack or vent).</p> <p><input type="checkbox"/> This Emissions Unit Information Section addresses, as a single emissions unit, a group of process or production units and activities which has at least one definable emission point (stack or vent) but may also produce fugitive emissions.</p> <p><input type="checkbox"/> This Emissions Unit Information Section addresses, as a single emissions unit, one or more process or production units and activities which produce fugitive emissions only.</p>		
<p>4. Description of Emissions Unit Addressed in This Section (limit to 60 characters):  <b>CRUMB RUBBER MILLING PLANT</b></p>		
<p>3. Emissions Unit Identification Number: <span style="float: right;"><input type="checkbox"/> No ID</span>                  ID: <b>001</b> <span style="float: right;"><input type="checkbox"/> ID Unknown</span></p>		
<p>4. Emissions Unit Status Code: <b>A</b></p>	<p>5. Initial Startup Date: <b>NA</b></p>	<p>6. Emissions Unit Major Group SIC Code: <b>30</b></p>
<p>5. Emissions Unit Comment: (Limit to 500 Characters)</p> <p><b>The tire milling emissions unit consists of a rotary shear type tire shredder, two cracker mills in series with air separation screens, three fine grind mills in parallel with air separation screens and intermediate holding and recycling bins. Particulate emissions from the air aspirated screening processes are vented through a common baghouse before being discharged to the atmosphere. Because of the enclosure of the process and the nature of the raw material and the product, there are no significant fugitive emissions associated with the process.</b></p>		

**Emissions Unit Control Equipment**

<p>4. Control Equipment/Method Description (limit to 200 characters per device or method):</p> <p><b>BAGHOUSE</b></p>
<p>2. Control Device or Method Code(s): <b>18</b></p>

**Emissions Unit Details**

<p>1. Package Unit:                  Manufacturer: <b>MAC ENVIRONMENTAL</b> Model Number: <b>144WMCF338</b></p>						
<p>2. Generator Nameplate Rating: <b>MW</b></p>						
<p>3. Incinerator Information:</p> <table style="width: 100%; border: none;"> <tr> <td style="text-align: right;">Dwell Temperature:</td> <td style="text-align: right;">°F</td> </tr> <tr> <td style="text-align: right;">Dwell Time:</td> <td style="text-align: right;">seconds</td> </tr> <tr> <td style="text-align: right;">Incinerator Afterburner Temperature:</td> <td style="text-align: right;">°F</td> </tr> </table>	Dwell Temperature:	°F	Dwell Time:	seconds	Incinerator Afterburner Temperature:	°F
Dwell Temperature:	°F					
Dwell Time:	seconds					
Incinerator Afterburner Temperature:	°F					

**Emissions Unit Operating Capacity and Schedule**

<p>1. Maximum Heat Input Rate: <b>mmBtu/hr</b></p>				
<p>2. Maximum Incineration Rate: <b>lb/hr</b> <b>tons/day</b></p>				
<p>3. Maximum Process or Throughput Rate: <b>29,000 LBS/HR, TIRE SHREDDING</b></p>				
<p>4. Maximum Production Rate: <b>6000 LBS/HR MESH SIZE CRUMB RUBBER</b></p>				
<p>5. Requested Maximum Operating Schedule:</p> <table style="width: 100%; border: none;"> <tr> <td style="text-align: center;">hours/day</td> <td style="text-align: center;">days/week</td> </tr> <tr> <td style="text-align: center;">weeks/year</td> <td style="text-align: center;"><b>8760 hours/year</b></td> </tr> </table>	hours/day	days/week	weeks/year	<b>8760 hours/year</b>
hours/day	days/week			
weeks/year	<b>8760 hours/year</b>			
<p>4. Operating Capacity/Schedule Comment (limit to 200 characters):  <b>Throughput Rate: is lbs/hr of whole passenger tire equivalents (WTEs)</b>  <b>Production Rate: is lbs/hr of mesh size crumb rubber.</b></p> <p><b>Max. Rates of individual Units: Shredder-14.5 tph, Primary Cracker Mill- 8 tph, Secondary Cracker Mill – 7 tph, Three Fine Grind Mills (total) – 3 tph, Air Separators – 8 tph</b></p> <p><b>The maximum annual production rate of crumb rubber is limited by the production rate of the 3 parallel fine grind mills. The maximum projected annual production rate is 20,000 tons of mesh size crumb rubber beads.</b></p>				

**B. EMISSION POINT (STACK/VENT) INFORMATION**

**Emission Point Description and Type**

1. Identification of Point on Plot Plan or Flow Diagram?		2. Emission Point Type Code: <b>1</b>	
3. Descriptions of Emission Points Comprising this Emissions Unit for VE Tracking (limit to 100 characters per point): <b>Horizontal baghouse vent</b>			
4. ID Numbers or Descriptions of Emission Units with this Emission Point in Common:			
5. Discharge Type Code:	6. Stack Height: <b>50 feet</b>	7. Exit Diameter: <b>APPROX 1.5 feet</b>	
8. Exit Temperature: <b>90°F</b>	9. Actual Volumetric Flow Rate: <b>39000 acfm</b>	10. Water Vapor: <b>3 %</b>	
11. Maximum Dry Standard Flow Rate: <b>dscfm</b>		12. Nonstack Emission Point Height: <b>feet</b>	
13. Emission Point UTM Coordinates: <b>Zone: 17                      East (km): 397.53                      North (km): 3192.08</b>			
14. Emission Point Comment (limit to 200 characters):			

**C. SEGMENT (PROCESS/FUEL) INFORMATION**

**Segment Description and Rate:** Segment  1  of  1

1. Segment Description (Process/Fuel Type) (limit to 500 characters):  <b>WASTE DISPOSAL – SHREDDING, TIRES</b>		
4. Source Classification Code (SCC): <b>265000002</b>		3. SCC Units: <b>TONS PROCESSED</b>
5. Maximum Hourly Rate: <b>14.5</b>	4. Maximum Annual Rate: <b>20,000</b>	6. Estimated Annual Activity Factor:
7. Maximum % Sulfur:	8. Maximum % Ash:	9. Million Btu per SCC Unit:
10. Segment Comment (limit to 200 characters):  <b>Final product is clean granular sized rubber beads</b>		

**Segment Description and Rate:** Segment   of

1. Segment Description (Process/Fuel Type ) (limit to 500 characters):		
2. Source Classification Code (SCC):		3. SCC Units:
4. Maximum Hourly Rate:	5. Maximum Annual Rate:	6. Estimated Annual Activity Factor:
7. Maximum % Sulfur:	8. Maximum % Ash:	9. Million Btu per SCC Unit:
10. Segment Comment (limit to 200 characters):		

**D. EMISSIONS UNIT POLLUTANT DETAIL INFORMATION**

**Potential Emissions**

1. Pollutant Emitted: <b>PM</b>		2. Pollutant Regulatory Code: <b>WP</b>	
3. Primary Control Device Code: <b>18</b>	4. Secondary Control Device Code:	5. Total Percent Efficiency of Control: <b>99.9</b>	
6. Potential Emissions: <p align="center">.46 lb/hour                      2.0 tons/year</p>		7. Synthetically Limited? [   ]	
8. Emission Factor:  Reference:		1) Emissions Method Code: <p align="center"><b>2</b></p>	
2) Calculation of Emissions (limit to 600 characters):  $20,000 \text{ TPY} \times 5\% \text{ (cord \& fiber)} + 20,000 \text{ TPY} \times 5\% \text{ (rubber dust \& foreign material)} = 2,000 \text{ TPY to baghouse}$  $2000 \text{ TPY} \times (1 - .999) = 2 \text{ TPY} / 8760 \text{ hrs/yr} = \underline{0.46 \text{ lbs/hr}}$			
1) Pollutant Potential Emissions Comment (limit to 200 characters): <b>Amount Entering Baghouse:</b> 1) Waste tire cord and tread (approx. 5% by weight of tires processed) 2) Rubber dust and foreign material (approx. 5% by weight of tires processed)			

**Allowable Emissions** Allowable Emissions NA of \_\_\_\_\_

1. Basis for Allowable Emissions Code:	2. Future Effective Date of Allowable Emissions:
3. Requested Allowable Emissions and Units:	4. Equivalent Allowable Emissions: <p align="center">lb/hour                      tons/year</p>
5. Method of Compliance (limit to 60 characters):	
6. Allowable Emissions Comment (Desc. of Operating Method) (limit to 200 characters):	





## G. EMISSIONS UNIT SUPPLEMENTAL INFORMATION

### Supplemental Requirements

1. Process Flow Diagram <input checked="" type="checkbox"/> Attached, Document ID: <u>C</u> <input type="checkbox"/> Not Applicable <input type="checkbox"/> Waiver Requested
2. Fuel Analysis or Specification <input type="checkbox"/> Attached, Document ID: _____ <input checked="" type="checkbox"/> Not Applicable <input type="checkbox"/> Waiver Requested
3. Detailed Description of Control Equipment <input checked="" type="checkbox"/> Attached, Document ID: <u>E</u> <input type="checkbox"/> Not Applicable <input type="checkbox"/> Waiver Requested
4. Description of Stack Sampling Facilities <input type="checkbox"/> Attached, Document ID: _____ <input checked="" type="checkbox"/> Not Applicable <input type="checkbox"/> Waiver Requested
5. Compliance Test Report <input type="checkbox"/> Attached, Document ID: _____ <input checked="" type="checkbox"/> Previously submitted, Date: <u>4/12/07</u> <input type="checkbox"/> Not Applicable
6. Procedures for Startup and Shutdown <input type="checkbox"/> Attached, Document ID: _____ <input checked="" type="checkbox"/> Not Applicable <input type="checkbox"/> Waiver Requested
7. Operation and Maintenance Plan <input type="checkbox"/> Attached, Document ID: _____ <input checked="" type="checkbox"/> Not Applicable <input type="checkbox"/> Waiver Requested
8. Supplemental Information for Construction Permit Application <input type="checkbox"/> Attached, Document ID: _____ <input type="checkbox"/> Not Applicable
9. Other Information Required by Rule or Statute <input type="checkbox"/> Attached, Document ID: _____ <input type="checkbox"/> Not Applicable
10. Supplemental Requirements Comment:

**DOCUMENT ID: A**

**AREA MAP**



**Area Map:**

Global Tire Recycling of Sumter County, Inc.  
 1201 Industrial Dr., Wildwood, FL  
 Lat: 28/51/14 Long: 82/03/02

**SOUTHERN ENVIRONMENTAL  
 SCIENCES, INC.**  
 1204 N. Wheeler Street  
 Plant City, Florida 33563-2354  
 (813) 752-5014 ☐ Fax (813) 752-2475

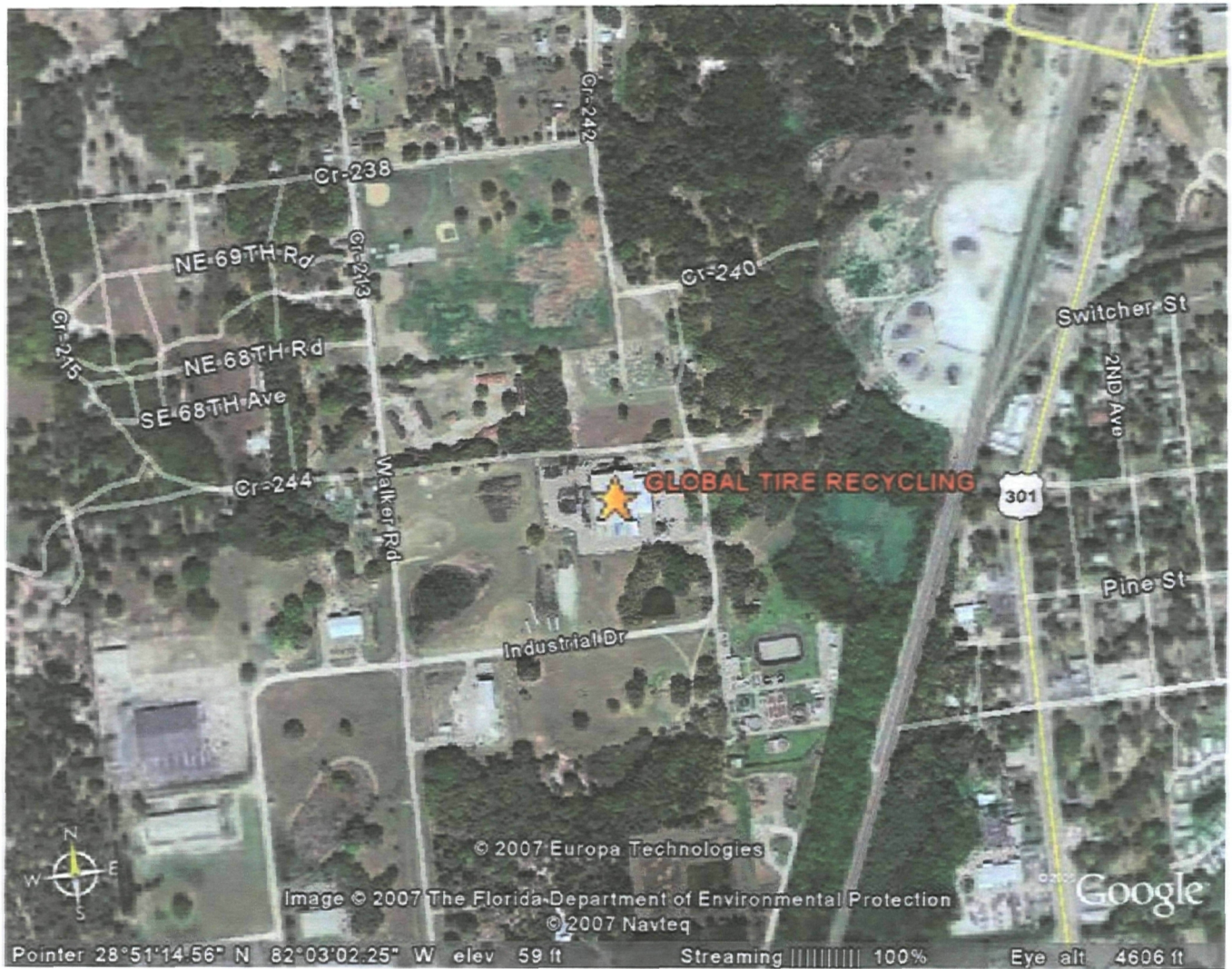

**Area Map:**

Global Tire Recycling of Sumter County, Inc.  
 1201 Industrial Dr., Wildwood, FL  
 Lat: 28/51/14 Long: 82/03/02

**SOUTHERN ENVIRONMENTAL  
 SCIENCES, INC.**

1204 N. Wheeler Street  
 Plant City, Florida 33563-2354  
 (813) 752-5014 ☐ Fax (813) 752-2475

**DOCUMENT ID: B**

**FACILITY PLOT PLAN**

An enlarged drawing is on file at the FDEP Southwest District Office

SENT 4-13-76

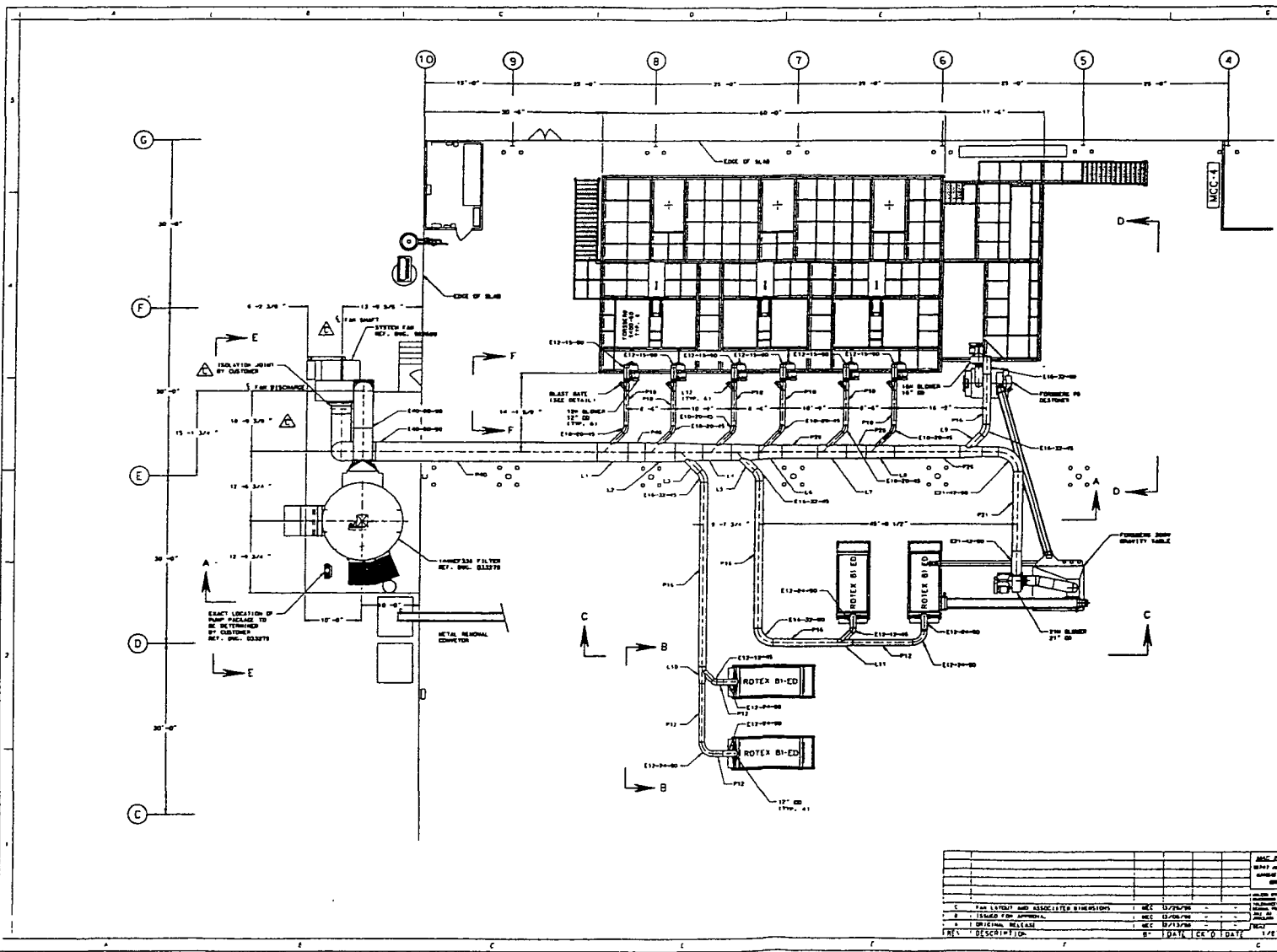

NOTE:  
TOP SECTIONAL VIEW SEE  
SPEC. 0045511, 0045512 & 004

**CERTIFIED**  
MAC EQUIPMENT, INC.  
By: *Steve McElroy* DATE: 03/24/76

DESIGNED BY	REV. 1	DATE	03/24/76
DRAWN BY	REV. 2	DATE	03/24/76
CHECKED BY	REV. 3	DATE	03/24/76
APPROVED BY	REV. 4	DATE	03/24/76
PROJECT DESCRIPTION	PLAN VIEW ASPIRATION SYSTEM		
PROJECT NO.	98-455-7C		
DATE	03/24/76		
SCALE	1/8" = 1'-0"		

MAC EQUIPMENT, INC.  
1000 S.W. 10TH AVENUE  
MIAMI, FLORIDA 33135  
PHONE (305) 351-1111  
TELETYPE (305) 351-1111  
FAX (305) 351-1111

**PROJECT**

PLAN VIEW  
ASPIRATION SYSTEM  
GLOBAL TIRE RECYCLING  
WILDWOOD FLORIDA

98-455-7C 9845510C

**DOCUMENT ID: C**

**PROCESS FLOW DIAGRAM**



WASTE TIRE RECEIVING,  
STORAGE, AND STAGING

TIRE SHREDDING

PRIMARY CRACKER  
MILLING

HOODED AIR  
SEPARATING SCREEN

SECONDARY  
CRACKER MILL

HOODED AIR  
SEPARATING SCREEN

FINE GRIND MILLING  
(3 IN PARALLEL)

HOODED AIR  
SEPARATING SCREEN

FINAL PRODUCT (MESH)  
SIZED CRUMB RUBBER)  
STAGING

PRODUCT BAGGING

TRUCK LOADOUT

Oversized Material

Oversized Material

Oversized Material

Particulate Emissions

Particulate Emissions

Particulate Emissions

To Atmosphere

8

8

3

8

13

13

7  
33

26280

**PROCESS FLOW DIAGRAM:**  
GLOBAL TIRE RECYCLING  
OF SUMTER COUNTY, INC.  
1201 INDUSTRIAL DRIVE  
WILDWOOD, FL 34785

**SOUTHERN ENVIRONMENTAL SCIENCES, INC.**  
1204 North Wheeler Street  
Plant City, Florida 33563  
(813) 752-5014, Fax (813) 752-2475

**DOCUMENT ID: D**

**PRECAUTIONS TO PREVENT  
UNCONFINED PARTICULATE EMISSIONS**

## **GLOBAL TIRE RECYCLING OF SUMTER COUNTY, INC.**

In accordance with 62-296.320(4)(c), the facility will take reasonable precautions to prevent emissions of unconfined particulate matter from the facility. Activities that can cause fugitive particulate emissions at the facility include vehicular movement, transportation of materials, and industrially related activities such as materials loading, unloading, storing, and handling. Reasonable precautions to be taken by the facility include:

1. All roads at the facility are paved.
2. The process is enclosed in a building.
3. Each air separator screen is equipped with a hood connected to a central baghouse to control emissions.

**DOCUMENT ID: E**  
**CONTROL EQUIPMENT DATA**

SENT 4-13-90

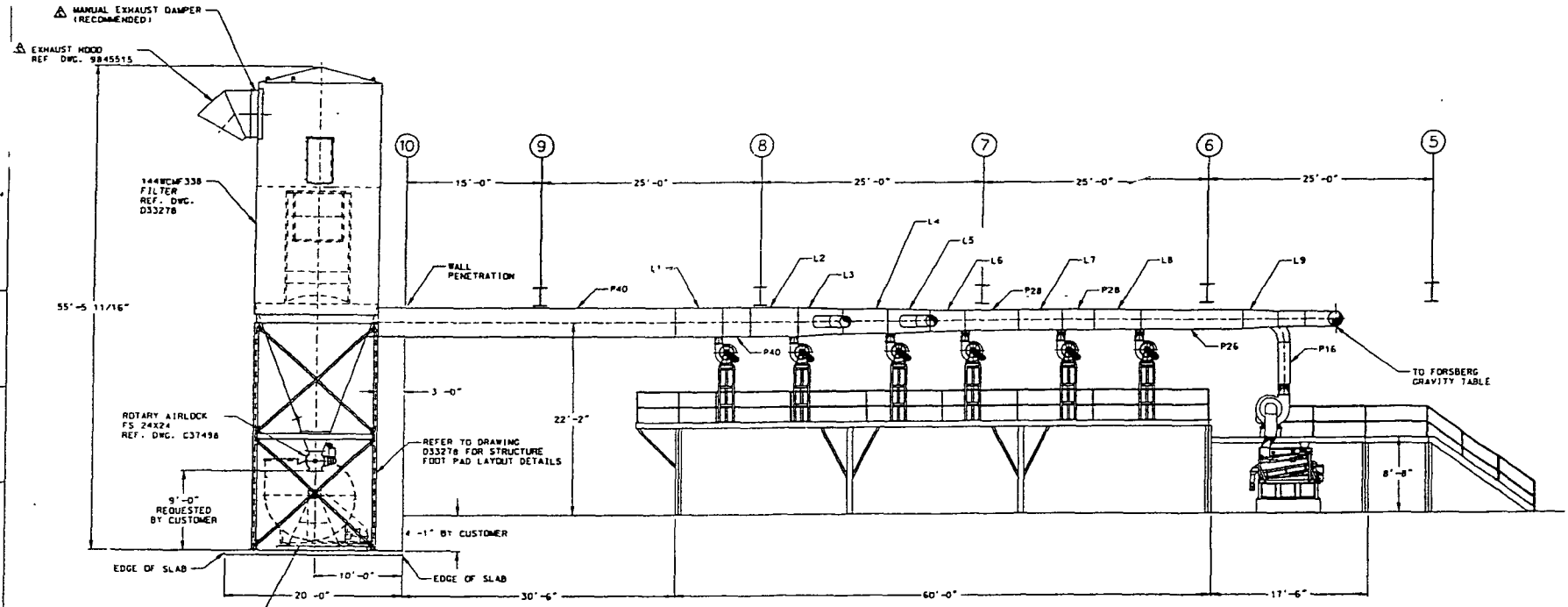

VIEW A-A

SYSTEM FAN  
REF. DWG 982609  
(TRANSITION #1 AND  
DUCTWORK NOT SHOWN  
FOR CLARITY)

**CERTIFIED**  
MAC EQUIPMENT, INC.  
BY: *Steve McNamee* DATE: 12/20/92

REV	DESCRIPTION	DATE	BY	CHECKED
1	REV. FAN LAYOUT/ADDED CONST HOOD/DAMP	11/29/90	ME	
2	ISSUED FOR APPROVAL	11/29/90	ME	
3	ORIGINAL RELEASE	01/13/91	ME	
4				
5				
6				
7				
8				
9				
10				



SECTIONAL VIEWS  
ASPIRATION SYSTEM  
GLOBAL TIRE RECYCLING  
WILDWOOD, FLORIDA

PROJECTS 138-455-7C | 9845511C

# TIRE GRINDING VENTILATION SYSTEM FOR MAC/SATURN GLOBAL TIRE PROJECT

SENT 4-13-98

MAC PROJECT # 98-455-7G

## DRAWING LIST

9845510	PLAN VIEW
9845511	SECTIONAL VIEW
9845512	SECTIONAL VIEW
9845513	SECTIONAL VIEW
9845514	FABRICATION DETAILS
9845515	FABRICATION DETAILS
D33278	FILTER
C37498	AIRLOCK
982609	FAN

### SYSTEM PARAMETERS

AIR VOLUME:	41,000 CFM @ -12" W.G.
TOTAL CLOTH AREA:	4,901 SQ. FT.
A/E RATIO:	8.5 TO 1
NO. BAGS:	388
MIN. DESIGN DUCT VELOCITY:	4,000 FPM
TEMPERATURE:	AMBIENT (MAX 250° F)
DUST:	RUBBER AND TIRE CORDAGE FIBES
VENTING:	BUCKET ELEVATORS, SHAKERS, GRINDERS, AND DESTONERS

### FIELD NOTES:

1. DUCT CONSTRUCTION DETAILS FOR ALL TRANSITIONS AND ELBOWS ARE SHOWN ON THE MATERIALS TABLE. STRAIGHTS ARE INDICATED AS TOTAL AMOUNT LENGTH. NOTE: CONTINGENCY IS NOT INCLUDED IN THE LISTED TOTAL LENGTHS.
2. USE SILICONE SEALER CAULK BETWEEN ALL BOLTED FLANGE CONNECTIONS TO PROVIDE AN AIRTIGHT SEAL.
3. ALL DUCT PENETRATIONS THROUGH THE BUILDING WALLS WILL BE FLASHED AS REQUIRED FOR WEATHERPROOFING.
4. ANCHOR BLOWER PACKAGES AND PLUMB 1 1/2" NPT PIPE FROM BLOWER OUTLET TO THE MCF 2 1/2" NPT CONNECTOR SUPPLIED ON THE BACKHOUSE SIDEWALL.
5. DUCT RUNS TO BE SUPPORTED BY INSTALLATION CONTRACTOR MINIMUM OF EVERY 10 FEET AND AS REQUIRED. HANGERS AND SUPPORTS SUPPLIED BY CONTRACTOR.
6. SUPPORT DUCTWORK IN A MANNER TO PLACE NO LOAD ON CONNECTING EQUIPMENT OR HOODS
7. FAN TO BE ANCHORED DIRECTLY TO CONCRETE PAD.
8. ALL STRAIGHT DUCT RUNS TO BE FABRICATED WITH ONE FLANGE LOOSE OR TACK WELDED FOR TRIM FIT AND SEAL WELDING IN FIELD
9. BLAST GATES TO BE INSTALLED AT ALL PICK UP HOODS TO CONTROL AIR FLOW
10. SEE MAC EQUIPMENT DRAWING NO D33278 FOR DUST COLLECTOR AND BLOWER PACKAGE ANCHOR BOLT PATTERNS.

### CONSTRUCTION/FABRICATION NOTES:

1. ALL DUCTWORK, FLANGES, HANGERS, SUPPORTS, BRACING AND BOLT PATTERNS SHALL BE CONSTRUCTED IN ACCORDANCE WITH THE LATEST EDITION OF THE "SHEET METAL AND AIR CONDITIONING NATIONAL ASSOCIATION, INC." MANUAL OF "ROUND INDUSTRIAL DUCT CONSTRUCTION STANDARDS" UNLESS OTHERWISE SPECIFIED.
2. ALL DUCTWORK CONSTRUCTION SHALL BE ROUND FLANGED DUCTWORK DESIGNED IN ACCORDANCE WITH THE "SMACNA" CLASS 2 MATERIAL AND REINFORCING SCHEDULES FOR STEEL DUCTS.
4. CENTERLINE RADII FOR ELBOWS TO BE 2 TIMES THE DIAMETER (LONG RADIUS) UNLESS OTHERWISE SPECIFIED.
3. ALL ELBOW FLANGES TO MATCH UP WITH CONNECTING DUCT DETAIL.
5. CLEAN OUT DOORS ARE TO BE PROVIDED FOR EVERY 10 FOOT OF STRAIGHT DUCT RUN OR NEAR EACH DUCT JUNCTION IN HORIZONTAL DUCT SECTIONS. SEE CLEAN OUT DOOR
6. MANUAL BLAST GATES MUST BE PROVIDED AT EACH HOOD OR PICK-UP LOCATION.
7. DUCT MATERIAL AND REINFORCEMENT SCHEDULES:

10" DIA. - 20 GAUGE STEEL - L 1x1x1/8 @ 10" SPACING
12" DIA. - 20 GAUGE STEEL - L 1x1x1/8 @ 7" SPACING
16" DIA. - 18 GAUGE STEEL - L 1x1x1/8 @ 9" SPACING
21" DIA. - 16 GAUGE STEEL - L 1x1x1/8 @ 9" SPACING
26" DIA. - 16 GAUGE STEEL - L 1 1/4x1 1/4x3/16 @ 7" SPACING
28" DIA. - 16 GAUGE STEEL - L 1 1/4x1 1/4x3/16 @ 6" SPACING
40" DIA. - 14 GAUGE STEEL - L 1 1/4x1 1/4x3/16 @ 4" SPACING
ELBOWS - 14 GAUGE STEEL
TRANSITIONS - 14 GAUGE STEEL

8. ALL DUCTWORK SHALL BE PRIME PAINTED AS PROTECTION AGAINST CORROSION

MATERIALS TABLE		
ITEM NO.	QTY./LENGTH	DESCRIPTION
P10	40'-0"	10" STEEL DUCT
P12	72'-0"	12" STEEL DUCT
P16	86'-0"	16" STEEL DUCT
P21	21'-0"	21" STEEL DUCT
P26	13'-0"	26" STEEL DUCT
P28	11'-0"	28" STEEL DUCT
P40	71'-0"	40" STEEL DUCT
E10-20-45	6	10" DUCT, 20" C.L. RAD., 45° ELBOW
E12-12-45	2	12" DUCT, 12" C.L. RAD., 45° ELBOW
E12-15-90	6	12" DUCT, 15" C.L. RAD., 90° ELBOW
E12-24-90	6	12" DUCT, 24" C.L. RAD., 90° ELBOW
E16-32-45	3	16" DUCT, 32" C.L. RAD., 45° ELBOW
E16-32-90	2	16" DUCT, 32" C.L. RAD., 90° ELBOW
E21-42-90	2	21" DUCT, 42" C.L. RAD., 90° ELBOW
E40-80-90	3	40" DUCT, 80" C.L. RAD., 90° ELBOW
L1	1	40"x 40"x 10" LATERAL 5'-5"/LENGTH
L2	1	40"x 40"x 10" LATERAL 5'-5"/LENGTH
L3	1	40"x 34"x 16" LATERAL 5'-0"/LENGTH
L4	1	34"x 34"x 10" LATERAL 5'-0"/LENGTH
L5	2	34"x 30"x 16" LATERAL 4'-9 1/8"/LENGTH
L6	1	30"x 28"x 10" LATERAL 4'-1"/LENGTH
L7	1	28"x 28"x 10" LATERAL 5'-0"/LENGTH
L8	1	28"x 26"x 10" LATERAL 5'-0"/LENGTH
L9	1	26"x 21"x 16" LATERAL 3'-11 9/16"/LENGTH
L10	1	16"x 12"x 12" LATERAL 3'-0"/LENGTH
L11	1	16"x 12"x 12" LATERAL 2'-8"/LENGTH
L12	6	12"x 10"x 08" LATERAL 1'-6"/LENGTH
BLAST GATES	6	8" DIA./SEE PLAN/SECTION VIEWS FOR LOCATION
BLAST GATES	10	12" DIA./SEE PLAN/SECTION VIEWS FOR LOCATION
TRANS 1	1	FAN EXHAUST TRANSITION
TRANS 2	1	FILTER INLET TRANSITION
TRANS 3	1	FAN INLET TRANSITION
EXHST HOOD	1	FILTER EXHAUST HOOD
ISOLN JOINT	1	FAN INLET ISOLATION JOINT
EXHST DAMPER	1	FILTER EXHAUST DAMPER

ISSUED FOR CONSTRUCTION	MCC 03/26/98	
ORIGINAL RELEASE	MCC 03/27/98	
REV. DESCRIPTION	BY DATE TCC D DATE	NONE

MCC PROJECT INC.  
2011 WINDYBROOK DRIVE  
AMERICA CITY, MO 64002  
TEL: 816-338-1100  
FAX: 816-338-1101  
WWW.MCCPROJECT.COM

**MCC PROJECTS**

THE GRINDING VENTILATION SYSTEM  
GLOBAL TIRE RECYCLE WILDMOOD FLORIDA  
98-455-7G COVER P.1

## EQUIPMENT INFORMATION

### Name of Item: Bag House (B-1)

- 1) **Quantity:** One  
**Model:** 144WMCF338 welded MCF filter  
**H.P.:** 5 HP
  
- 2) **Manufacturer:** MAC Environmental  
**Address:** 623 McWay Drive West  
**City/State/Zip:** High Point, NC 27263  
  
**Contact Person:** Larry Walker      **Telephone:** 817-558-4146
  
- 3) **Cost:** FOB Plant: \$135,250.00      **Freight:**
  
- 4) **Net Weight:** 29,300 lbs.      **Height:**      **Width:** 14'      **Depth:** 14'
  
- 5) **Capacity:** 39,000 ACFM at 20" +/- SP
  
- 6) **Dealer:** MAC/Saturn  
**Address:** 201 East Shady Grove Road  
**City/State/Zip:** Grand Prairie, TX 75050  
  
**Contact Person:** John Crowley      **Telephone:** 972-790-7800
  
- 7) **Order Date for**      **Delivery:**
  
- 8) **Pay to:** MAC/Saturn  
**Address:** See above  
**City/State/Zip:**
  
- 9) **Recommended Spare Parts and Prices List:** See Attachment 1
  
- 10) **Maintenance Schedule/Downtime Associated with Scheduled Maintenance:** See Attachment 2
  
- 11) **Referrals List:** See Attachment 3
  
- 12) **Brochure/Company Profile:** See Attachment 4
  
- 13) **Blueprint/Drawing:** See Attachment 5
  
- 14) **Miscellaneous:** Price includes MAC model FS 24x24 heavy duty fabricated rotary airlock and Airtech model 445-85 class 4 fan.

**The MCF**

**it is**

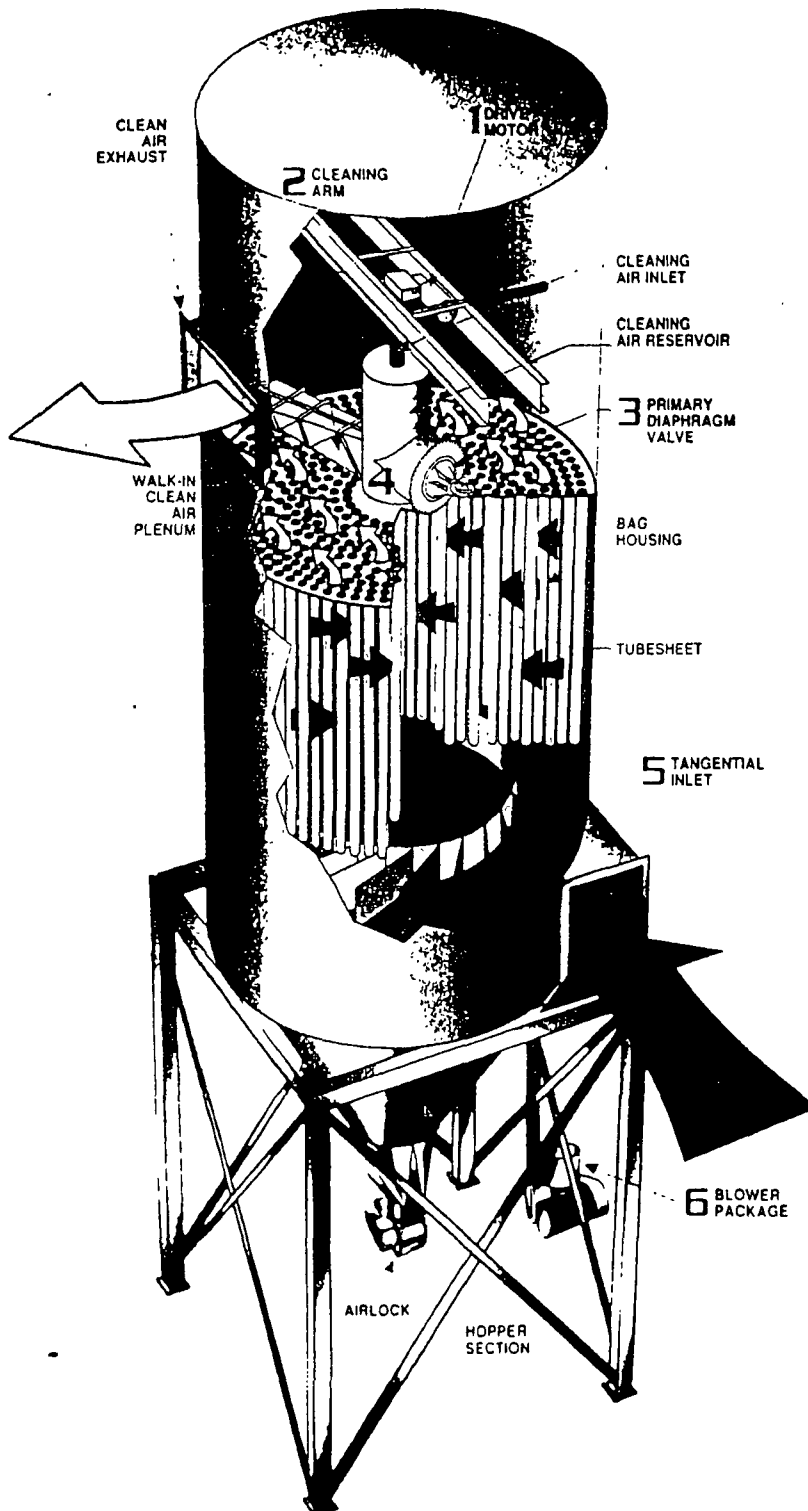

**it works**

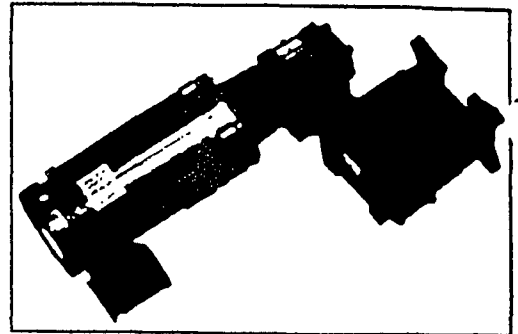

**1 Main Drive uses rugged electric motor**  
The Main Drive Assembly represents the only electronic component used inside the filter housing. Except for this motor and the external air blower package, the MCF is pneumatically operated for added safety and reliability.

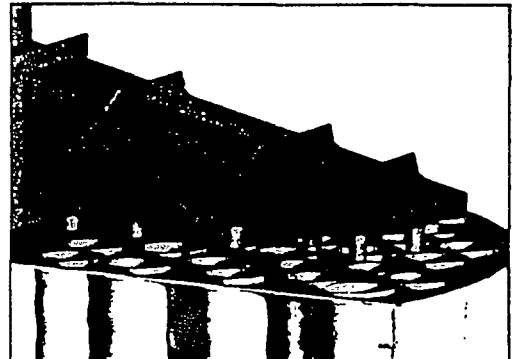

**2 Cleaning Arm directs air flow**  
When the cleaning arm and bag segments are correctly aligned, air nozzles fire directly into the bags. So there's no wasted air. No bleed. None of the wasted energy you pay for on every cycle with conventional random-fire and reverse-air systems. MAC invented and patented this Never-Miss™ Controlled-Fire System to maximize cleaning efficiency.

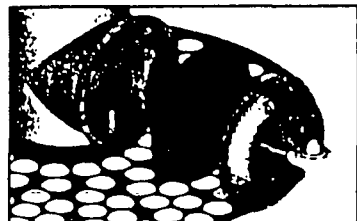

**3 Diaphragm Valving Assemblies minimize recovery time**

Primary and Secondary Valves are located close to the air reservoir and cleaning arm to maintain cleaning pressure. These two valves do the work of ten to thirty diaphragm valves and solenoids on conventional pulse-jet filters.





# MAC Environmental

# DATA SHEET

800-821-2476

City

Houston

Las Vegas

High Point

Subtotal

## WIDE BAG SPACING WMCF\* FILTER with Low Pressure Tangential Inlet (Plain Discharge)

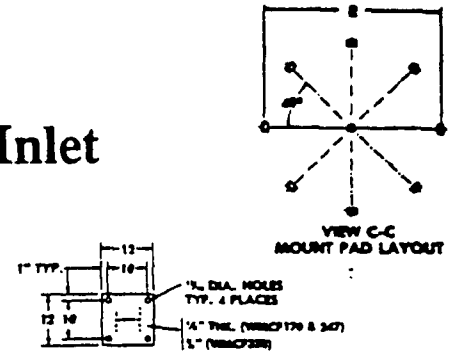
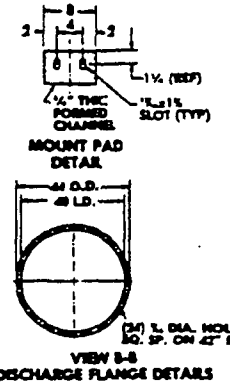
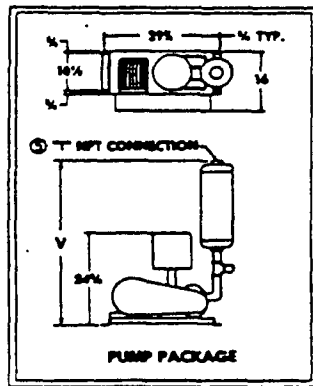
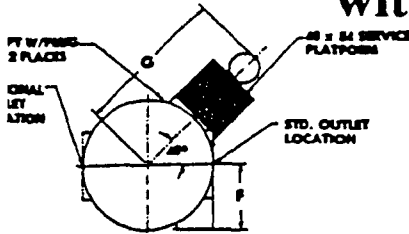

- NOTES:**
1. All dimensions are in inches
  2. 10 ga. C.S. construction - WMCFM170 & 247  
7 ga. C.S. construction - WMCF338
  3. Std. number of explosion vents provide a 30:1 volume to vent ratio
  4. If center space equals more than 6" there will be a bolt hole on the centerline
  5. Customer to provide supply line from pump plug. outlet to connection on filter.

### STANDARD SPECIFICATIONS FOR MAC WMCF PUMP PACKAGE

#### Materials of Construction

- Carbon steel horizontal base
- Full welded exterior base assembly
- Major Components**
- Positive displacement blower
- Horizontal blower frame assembly
- Adjustable motor base
- TEFC Motor 230/460/3/1800
- Air intake filter
- V-belt drive
- Belt guard
- Pressure relief valve at 10 PSI
- Outlet silencer
- Necessary hardware
- Pressure gauge 0-15 PSI and shut off valve

#### Paint

- Standard cleaning and metal preparation
- Interior and exterior primed with one coat of gray primer
- Exterior to have one finish coat
- Color to be specified:  
Standard color is MAC Blue  
Alternate standard color is MAC White

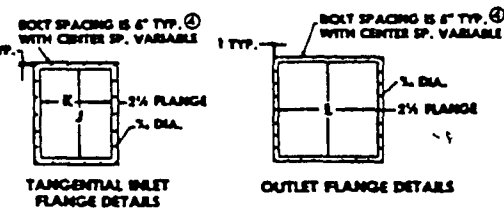
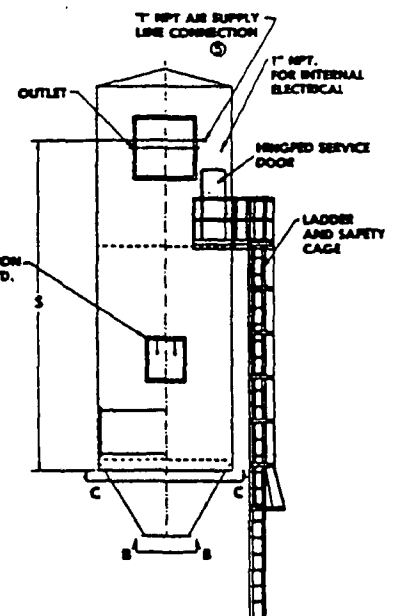
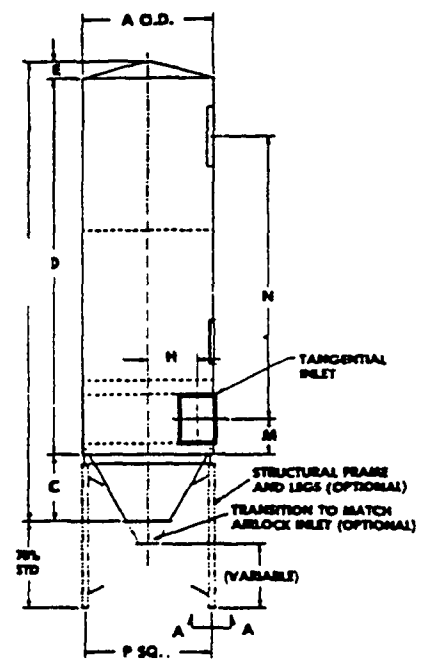

MODEL	SQ. FT. CLOTH	A	B	C	D	E	F	G	H	J	K	L	M	N	P	R	S	T	U	V	BLOWER H.P.	WT/ LBS
96WMCF170	1649	120	339 <sup>1</sup> / <sub>16</sub>	58 <sup>9</sup> / <sub>16</sub>	264 <sup>1</sup> / <sub>8</sub>	16	60	149 <sup>1</sup> / <sub>4</sub>	45	40	30	38	32	201	114 <sup>1</sup> / <sub>4</sub>	117 <sup>1</sup> / <sub>2</sub>	249 <sup>1</sup> / <sub>8</sub>	1 <sup>1</sup> / <sub>2</sub>	5	41 <sup>7</sup> / <sub>16</sub>	3	11250
120WMCF170	2057	120	291 <sup>1</sup> / <sub>16</sub>	59 <sup>9</sup> / <sub>16</sub>	316 <sup>1</sup> / <sub>8</sub>	16	60	149 <sup>1</sup> / <sub>4</sub>	43	44	34	42	34	249	114 <sup>1</sup> / <sub>4</sub>	117 <sup>1</sup> / <sub>2</sub>	277 <sup>1</sup> / <sub>8</sub>	1 <sup>1</sup> / <sub>2</sub>	5	41 <sup>7</sup> / <sub>16</sub>	3	12070
144WMCF170	2465	120	444 <sup>1</sup> / <sub>16</sub>	59 <sup>9</sup> / <sub>16</sub>	369 <sup>1</sup> / <sub>8</sub>	16	60	149 <sup>1</sup> / <sub>4</sub>	42	49	36	46	36 <sup>1</sup> / <sub>2</sub>	297 <sup>1</sup> / <sub>2</sub>	114 <sup>1</sup> / <sub>4</sub>	117 <sup>1</sup> / <sub>2</sub>	306 <sup>1</sup> / <sub>8</sub>	1 <sup>1</sup> / <sub>2</sub>	6	41 <sup>7</sup> / <sub>16</sub>	3	12995
96WMCF247	2395	144	370 <sup>1</sup> / <sub>16</sub>	80	271 <sup>1</sup> / <sub>2</sub>	19 <sup>1</sup> / <sub>4</sub>	72	161 <sup>1</sup> / <sub>4</sub>	54	47	36	45	35 <sup>1</sup> / <sub>2</sub>	201	138 <sup>3</sup> / <sub>4</sub>	141 <sup>1</sup> / <sub>2</sub>	250 <sup>1</sup> / <sub>8</sub>	2	7	40 <sup>1</sup> / <sub>16</sub>	3	14140
120WMCF247	2988	144	477 <sup>1</sup> / <sub>16</sub>	80	325 <sup>1</sup> / <sub>8</sub>	19 <sup>1</sup> / <sub>4</sub>	72	161 <sup>1</sup> / <sub>4</sub>	52	53	40	50	38 <sup>1</sup> / <sub>2</sub>	249 <sup>1</sup> / <sub>2</sub>	138 <sup>3</sup> / <sub>4</sub>	141 <sup>1</sup> / <sub>2</sub>	306 <sup>1</sup> / <sub>16</sub>	2	8	40 <sup>1</sup> / <sub>16</sub>	5	15085
144WMCF247	3581	144	477 <sup>1</sup> / <sub>16</sub>	80	378	19 <sup>1</sup> / <sub>4</sub>	72	161 <sup>1</sup> / <sub>4</sub>	50 <sup>1</sup> / <sub>2</sub>	58	43	55	41	297 <sup>1</sup> / <sub>2</sub>	138 <sup>3</sup> / <sub>4</sub>	141 <sup>1</sup> / <sub>2</sub>	335 <sup>1</sup> / <sub>16</sub>	2	9	40 <sup>1</sup> / <sub>16</sub>	5	16340
96WMCF338	3278	168	402 <sup>1</sup> / <sub>16</sub>	100 <sup>1</sup> / <sub>16</sub>	279 <sup>1</sup> / <sub>8</sub>	22 <sup>1</sup> / <sub>16</sub>	84	173 <sup>1</sup> / <sub>4</sub>	63	55	42	53	39 <sup>1</sup> / <sub>2</sub>	201	162	165 <sup>1</sup> / <sub>8</sub>	258 <sup>1</sup> / <sub>8</sub>	2 <sup>1</sup> / <sub>2</sub>	10	41 <sup>1</sup> / <sub>8</sub>	5	17910
120WMCF338	4089	168	457 <sup>1</sup> / <sub>16</sub>	100 <sup>1</sup> / <sub>16</sub>	334 <sup>1</sup> / <sub>8</sub>	22 <sup>1</sup> / <sub>16</sub>	84	173 <sup>1</sup> / <sub>4</sub>	61	62	46	59	43	249 <sup>1</sup> / <sub>2</sub>	162	165 <sup>1</sup> / <sub>8</sub>	315 <sup>1</sup> / <sub>16</sub>	2 <sup>1</sup> / <sub>2</sub>	11	41 <sup>1</sup> / <sub>8</sub>	5	19020
144WMCF338	4901	168	511 <sup>1</sup> / <sub>16</sub>	100 <sup>1</sup> / <sub>16</sub>	388 <sup>1</sup> / <sub>8</sub>	22 <sup>1</sup> / <sub>16</sub>	84	173 <sup>1</sup> / <sub>4</sub>	58 <sup>1</sup> / <sub>2</sub>	68	51	64	46	298	162	165 <sup>1</sup> / <sub>8</sub>	345 <sup>1</sup> / <sub>16</sub>	2 <sup>1</sup> / <sub>2</sub>	13	41 <sup>1</sup> / <sub>8</sub>	5	20500

\*Patent No. 4,655,799

Information on this page subject to change without notice.

# WIDE BAG SPACING WMCF\* FILTER with High Entry Inlet (Plain Discharge)

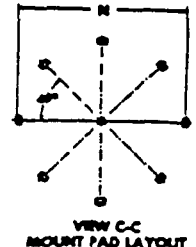
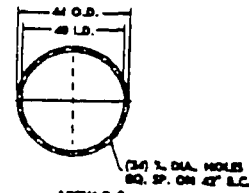
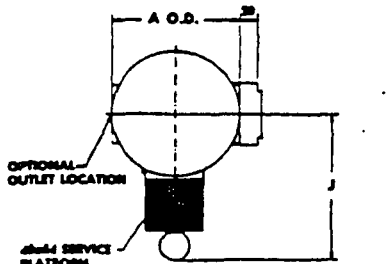

## STANDARD SPECIFICATIONS FOR MAC WMCF FILTER

### Materials of Construction

Carbon steel construction, 10, 7 ga. per Mfr. Drawing  
Full welded exterior, skip welded interior  
One piece, all welded construction  
Filter media - 16 oz. singed polyester  
Major Components

Walk-in plenum  
Gear drive rotating surge tank, diaphragm valve, and distribution arm, with a 1 HP explosion proof (NEMA 9) motor  
Pneumatically controlled firing mechanism which activates the diaphragm valves  
Service door, 60" tall x 32" wide, gasketed and hinged to left side  
Bolt on high entry inlet with bag protector baffles  
Standard number of explosion vents sized at 30:1 volume to vent ratio; bolt on frame assembly vents  
Snap band top bag removal, 16 oz. polyester singed bags  
Top removal rigid wire galvanized bag cage  
60" hopper with 40" diameter flange  
40" transition to match airlock inlet (optional)  
Pressure differential gauge kit  
Lifting lugs (4 ea.) on top plenum  
Ladder, safety cage  
Service platform with guardrail

### Paint

Standard cleaning and metal preparation  
Interior and exterior primed with one coat of gray primer  
Exterior to have one finish coat  
Color to be specified:  
Standard color is MAC Blue  
Alternate standard color is MAC White

### NOTES:

- All dimensions are in inches
- 10 ga. C.S. construction - WMCF170 & 247  
7 ga. C.S. construction - WMCF338
- Std. number of explosion vents provide a 35:1 volume to vent ratio
- If center space equals more than 8" there will be a bolt hole on the centerline
- Customer to provide supply line from pump plug, outlet to connection on filter

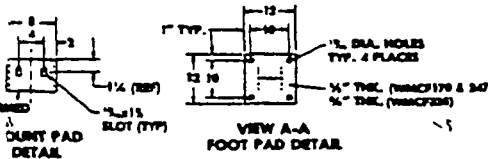
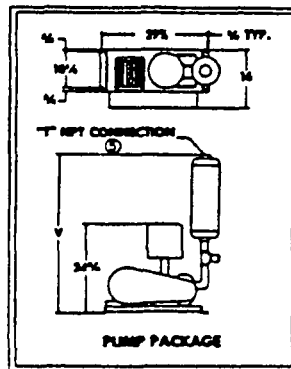
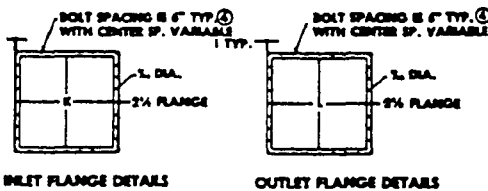
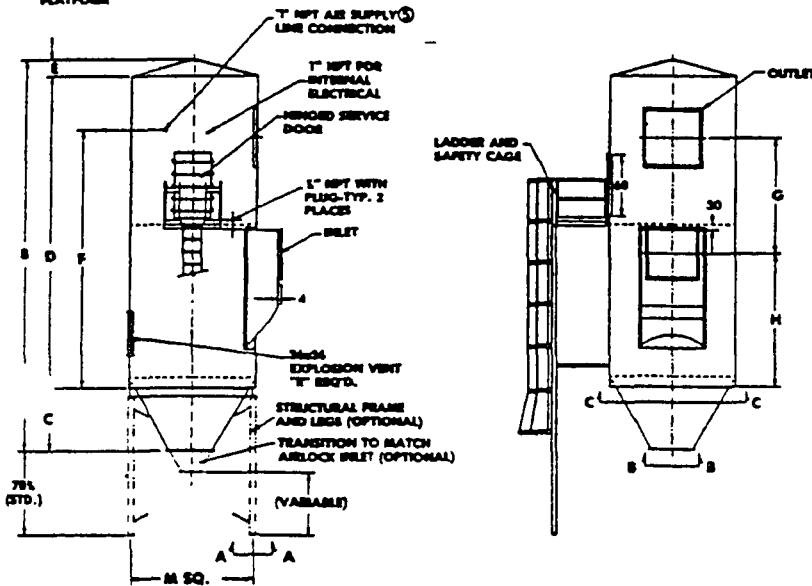

MODEL	SQ. FT. CLOTH	A	B	C	D	E	F	G	H	J	K	L	M	N	R	T	V	BLOWER H.P.	WT/LBS
96WMCF170	1649	120	301 <sup>1</sup> / <sub>4</sub>	59 <sup>1</sup> / <sub>4</sub>	226	16	211 <sup>1</sup> / <sub>4</sub>	89 <sup>1</sup> / <sub>2</sub>	105	149 <sup>1</sup> / <sub>4</sub>	38	38	114 <sup>3</sup> / <sub>4</sub>	117 <sup>1</sup> / <sub>2</sub>	4	1 <sup>1</sup> / <sub>2</sub>		3	8795
120WMCF170	2057	120	349 <sup>1</sup> / <sub>4</sub>	59 <sup>1</sup> / <sub>4</sub>	274	16	235 <sup>1</sup> / <sub>4</sub>	113 <sup>1</sup> / <sub>2</sub>	127	149 <sup>1</sup> / <sub>4</sub>	42	42	114 <sup>3</sup> / <sub>4</sub>	117 <sup>1</sup> / <sub>2</sub>	4	1 <sup>1</sup> / <sub>2</sub>	41 <sup>3</sup> / <sub>4</sub>	3	9515
144WMCF170	2465	120	397 <sup>1</sup> / <sub>4</sub>	59 <sup>1</sup> / <sub>4</sub>	322	16	259 <sup>1</sup> / <sub>4</sub>	137 <sup>1</sup> / <sub>2</sub>	149	149 <sup>1</sup> / <sub>4</sub>	46	46	114 <sup>3</sup> / <sub>4</sub>	117 <sup>1</sup> / <sub>2</sub>	5	1 <sup>1</sup> / <sub>2</sub>		3	10255
96WMCF247	2395	144	328 <sup>1</sup> / <sub>4</sub>	80	229	19 <sup>1</sup> / <sub>4</sub>	207 <sup>1</sup> / <sub>4</sub>	89 <sup>1</sup> / <sub>2</sub>	104 <sup>1</sup> / <sub>2</sub>	161 <sup>1</sup> / <sub>4</sub>	45	45	138 <sup>3</sup> / <sub>4</sub>	141 <sup>1</sup> / <sub>2</sub>	6	2		3	11440
120WMCF247	2988	144	373 <sup>1</sup> / <sub>4</sub>	80	274	19 <sup>1</sup> / <sub>4</sub>	255 <sup>1</sup> / <sub>4</sub>	113 <sup>1</sup> / <sub>2</sub>	123	161 <sup>1</sup> / <sub>4</sub>	50	50	138 <sup>3</sup> / <sub>4</sub>	141 <sup>1</sup> / <sub>2</sub>	6	2	42 <sup>1</sup> / <sub>4</sub>	5	12230
144WMCF247	3581	144	421 <sup>1</sup> / <sub>4</sub>	80	322	19 <sup>1</sup> / <sub>4</sub>	279 <sup>1</sup> / <sub>4</sub>	137 <sup>1</sup> / <sub>2</sub>	144 <sup>1</sup> / <sub>2</sub>	161 <sup>1</sup> / <sub>4</sub>	55	55	138 <sup>3</sup> / <sub>4</sub>	141 <sup>1</sup> / <sub>2</sub>	7	2		5	13140
96WMCF338	3278	168	370 <sup>1</sup> / <sub>4</sub>	100 <sup>1</sup> / <sub>4</sub>	247	22 <sup>1</sup> / <sub>4</sub>	225 <sup>1</sup> / <sub>4</sub>	89 <sup>1</sup> / <sub>2</sub>	118 <sup>1</sup> / <sub>2</sub>	173 <sup>1</sup> / <sub>4</sub>	53	53	162	165 <sup>1</sup> / <sub>2</sub>	7	2 <sup>1</sup> / <sub>2</sub>		5	15285
120WMCF338	4089	168	415 <sup>1</sup> / <sub>4</sub>	100 <sup>1</sup> / <sub>4</sub>	338	22 <sup>1</sup> / <sub>4</sub>	273 <sup>1</sup> / <sub>4</sub>	113 <sup>1</sup> / <sub>2</sub>	136 <sup>1</sup> / <sub>2</sub>	173 <sup>1</sup> / <sub>4</sub>	59	59	162	165 <sup>1</sup> / <sub>2</sub>	8	2 <sup>1</sup> / <sub>2</sub>	42 <sup>1</sup> / <sub>4</sub>	5	16190
144WMCF338	4901	168	481 <sup>1</sup> / <sub>4</sub>	100 <sup>1</sup> / <sub>4</sub>	338	22 <sup>1</sup> / <sub>4</sub>	295 <sup>1</sup> / <sub>4</sub>	137 <sup>1</sup> / <sub>2</sub>	156	173 <sup>1</sup> / <sub>4</sub>	64	64	162	165 <sup>1</sup> / <sub>2</sub>	10	2 <sup>1</sup> / <sub>2</sub>		5	17160

# MAC Environmental

Highway 75 S. • Box 205 • Sahelha, KS 66534 • (913) 284-2191 • 800-223-2191 • Fax 913-284-3565  
 10741 Ambassador Drive • Kansas City, MO 64153 • (816) 891-9100 • 800-821-2476 • Fax 816-891-8978  
 621 McWay Dr. West • High Point, NC 27263 • (910) 434-3802 • 800-882-0622 • Fax 910-434-3803  
 6655 W. Sahara • Las Vegas, NV 89102 • (702) 221-1910 • 800-442-0622 • Fax 702-221-8044

Effective 7-17-91  
 Supersedes 3-15-90

## HEAVY DUTY FABRICATED AIRLOCKS with Square Inlet

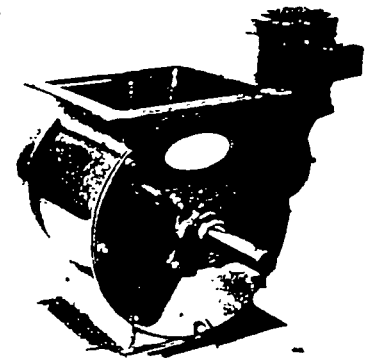
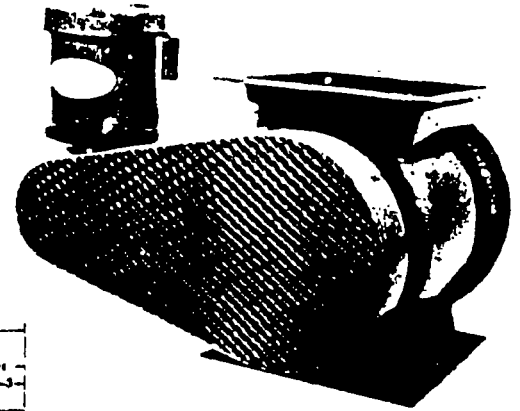
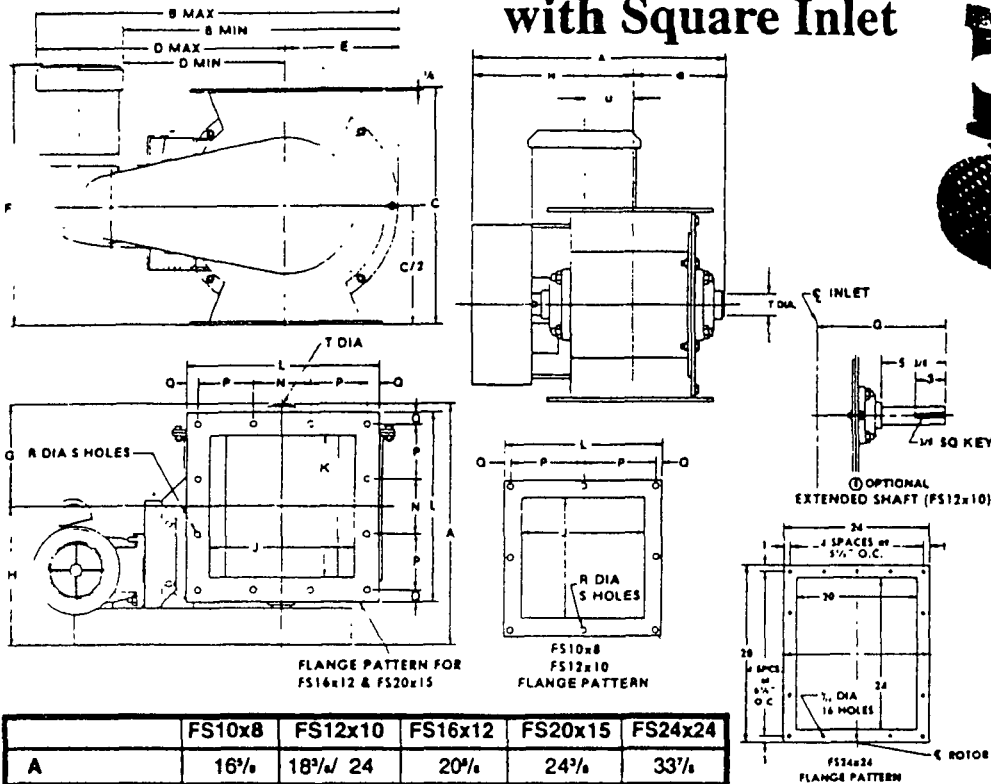

	FS10x8	FS12x10	FS16x12	FS20x15	FS24x24
A	16 <sup>3</sup> / <sub>16</sub>	18 <sup>1</sup> / <sub>2</sub> 24	20 <sup>3</sup> / <sub>16</sub>	24 <sup>3</sup> / <sub>16</sub>	33 <sup>3</sup> / <sub>16</sub>
B MIN	16 <sup>15</sup> / <sub>16</sub>	19 <sup>3</sup> / <sub>16</sub>	23 <sup>3</sup> / <sub>16</sub>	27 <sup>3</sup> / <sub>16</sub>	31 <sup>3</sup> / <sub>16</sub>
B MAX	25 <sup>3</sup> / <sub>16</sub>	27 <sup>3</sup> / <sub>16</sub>	31 <sup>3</sup> / <sub>16</sub>	35 <sup>3</sup> / <sub>16</sub>	39 <sup>3</sup> / <sub>16</sub>
C	13	16	20	24	28
D MIN	10 <sup>13</sup> / <sub>16</sub>	11 <sup>1</sup> / <sub>16</sub>	13 <sup>1</sup> / <sub>16</sub>	15 <sup>13</sup> / <sub>16</sub>	18 <sup>1</sup> / <sub>16</sub>
D MAX	19 <sup>1</sup> / <sub>16</sub>	20 <sup>1</sup> / <sub>16</sub>	22 <sup>1</sup> / <sub>16</sub>	24 <sup>1</sup> / <sub>16</sub>	26 <sup>3</sup> / <sub>16</sub>
E	6 <sup>1</sup> / <sub>16</sub>	7 <sup>1</sup> / <sub>2</sub>	9 <sup>1</sup> / <sub>2</sub>	11 <sup>1</sup> / <sub>2</sub>	13 <sup>1</sup> / <sub>2</sub>
F	26 <sup>3</sup> / <sub>16</sub>	27 <sup>3</sup> / <sub>16</sub>	29 <sup>3</sup> / <sub>16</sub>	31 <sup>3</sup> / <sub>16</sub>	33 <sup>3</sup> / <sub>16</sub>
G	6 <sup>1</sup> / <sub>16</sub>	7 / 12 <sup>3</sup> / <sub>16</sub>	8 <sup>1</sup> / <sub>16</sub>	10 <sup>1</sup> / <sub>16</sub>	14 <sup>3</sup> / <sub>16</sub>
H	10 <sup>3</sup> / <sub>16</sub>	11 <sup>3</sup> / <sub>16</sub>	12 <sup>3</sup> / <sub>16</sub>	14 <sup>1</sup> / <sub>16</sub>	19 <sup>1</sup> / <sub>16</sub>
J	8	10	12	15	20
K	8	10	12	15	24
L	11	13	16	19	24
N	—	—	4 <sup>1</sup> / <sub>16</sub>	6	—
P	4 <sup>1</sup> / <sub>16</sub>	6	4 <sup>11</sup> / <sub>16</sub>	5 <sup>1</sup> / <sub>2</sub>	—
Q	<sup>3</sup> / <sub>16</sub>	<sup>1</sup> / <sub>2</sub>	1	1	1
R	<sup>7</sup> / <sub>16</sub>	<sup>7</sup> / <sub>16</sub>	<sup>7</sup> / <sub>16</sub>	<sup>9</sup> / <sub>16</sub>	<sup>9</sup> / <sub>16</sub>
S	8	8	12	12	16
T	1 <sup>1</sup> / <sub>16</sub>	1 <sup>1</sup> / <sub>16</sub>	1 <sup>1</sup> / <sub>16</sub>	1 <sup>11</sup> / <sub>16</sub>	1 <sup>11</sup> / <sub>16</sub>
U	3 <sup>1</sup> / <sub>16</sub>	4 <sup>1</sup> / <sub>16</sub> / 3 <sup>1</sup> / <sub>16</sub>	4 <sup>1</sup> / <sub>16</sub>	6 <sup>1</sup> / <sub>16</sub>	9 <sup>1</sup> / <sub>2</sub>
HP	1	1 / 1 <sup>1</sup> / <sub>2</sub>	1 <sup>1</sup> / <sub>2</sub>	2	3
Weight (LBS)	125	160	225	325	510
Capacity CFR	.34	.62	1.32	2.60	6.00

Contact factory for more dimensional information on units larger than FS24x24.  
 FS30x30 and larger airlocks are not dimensionally interchangeable with HD30x30  
 and larger airlocks.

STANDARD SPECIFICATIONS FOR MAC FABRICATED AIRLOCKS  
 MODELS FS10x8, FS12x10, FS16x12, FS20x15, FS24x24, FS30x30, FS36x36,  
 FS36x42, FS42x42, FS48x48, FR16x12 (see back), FR20x16 (see back)

### Materials of Construction

Fabricated carbon steel housing  
 Carbon steel end plates  
 Carbon steel, urethane sandwich rotor

### Major Components

Fabricated non-machined, carbon steel housing  
 Fabricated carbon steel end plates with 4-bolt flange bearings  
 6-vane, carbon steel graphite filled, urethane flex 10 sandwich rotor construction  
 Rotation (as viewed from drive end):

Clockwise for Models FS30x30, FS36x36, FS36x42, FS42x42 & FS48x48  
 Counter-clockwise for all other models

### Paint

Standard cleaning and metal preparation  
 Exterior primed with one coat of gray primer  
 Exterior to have one finish coat

Color to be specified:

Standard color is MAC Blue  
 Alternate standard color is MAC White

NOTE: Maximum operating temperature is 220 degrees F.

FS10x8 thru FS24x24, FR16x12 & FR20x16 have right angle drives  
 FS30x30 and larger have shaft mount drives

### NOTES:

- All dimensions are in inches
- Gearmotors are 230/460 volt 3 phase 60 HZ TEFC standard, explosion proof optional
- 18 RPM is standard, except FS24x24 is 24 RPM
- Housing and flanges are 1/2" HRCS
- Rotor is 6 vane wiper style
- Bearings are sealed self-aligning 4 bolt flange units with single row ball bearing; lubrication is by pressure fitting through hole in outer race
- Rotation is CCW from drive end
- Optional extended shaft with slave drive only

**SPARE PARTS**

**FOR**

**Equipment: Bag House**

**Manufactured by: MAC Environmental**

RE: MAC Job #: 98-455\*7G

Listed below is a recommended stocking level of spare parts for our equipment listed below. I need to stress that the parts and prices listed are **ESTIMATES ONLY**. This quote is being done as a customer courtesy for MAC Saturn, so that you may comply with your regulatory agencies. At the time of this quote job 98-455\*7G has **NOT BEEN ENGINEERED**. All parts, prices & quantities are subject to change. A revised quote will be sent at a later date.

Item 1: 144MCF338 filter

338	Bags	\$10.70 each
338	Cages	\$19.35 each
1	Gear reducer	\$1418.00
1	SF cplg, 1 1/4"	\$29.00
1	SF cplg., 1 3/8"	\$29.00
1	SF cplg. Sleeve	\$30.00
1	Btm. Bearing	\$146.00
1	Top Bearing	\$69.00
1	Inlet tee assy.	\$270.00
1	Inlet tee shaft	\$94.00
1	Main diaph.	\$339.00
1	Diaph. Spring	\$49.00
1	Valve head assy.	\$315.00
1	Index sens. Spkkt.	\$84.00
1	Sec. Diaph. Kit	\$144.00
1	Alt-valve kit	\$65.00

Item 2: MCF pump kit

1	Blower (bare)	\$989.00
1	Intake filter elem.	\$65.00
1	Pressure gauge	\$65.00
1	Press. Relief vlv.	\$235.00
1	Press. Switch	\$170.00

Item 3: FS 24x24 airlock

2	Bearings	\$102.50
6	Blade tips	\$179.00

Most items are stock in our Kansas City Missouri warehouse. Lead times may be up to 4 weeks on some items if they need to be manufactured. All prices are FOB ship[ping] point and do not include shipping, tax, insurance or any duties. Terms are NET 30 from date of invoice (shipment).

MAINTENANCE ITEMS

For MCF Filter: ( See Maintenance pages 1 - 12 att'd)

<u>Description</u>	<u>Frequency</u>	<u>Estimated Downtime</u>
1) Check filter bags for excessive wear.	3 mos	1 hr
2) Check for evidence of moisture or dust buildup inside the filter.	6 mos	1 hr
3) Check oil in all gear motors.	6 mos	1 hr
4) Check belt tension on all V-belt drives.	6 mos	30 min.
5) Lubricate pump.	6 mos	15 min
6) Lubricate pump bearings.	9 weeks	15 min
7) Lubricate gear boxes (internal).	6 mos	1 hr
8) Bearings -	1 yr	2-3 hrs
9) Adjust Index Sensor Timing	As needed, depending on filter pressure differential(2 hr req'd)	
10) Replace large diaphragm	As needed, typically every 6mo to 2 yrs ( 15 min req'd)	
11) Replace all filter bags	As needed, depending on operating conditions and press. differential (1-3 days req'd)	

For FS Airlock:

1) Grease flange bearings	1000 hrs	10 min
2) Inspect wiper blades	Whenever baghouse is down, or at least every 60 days ( 1 hr req'd)	
3) Replace wiper blades	As needed, depending on wear (2-3 hrs req'd)	
4) Check tension of drive chain	200 hrs	15 min
5) Inspect sprockets, chain, base structure, drive guard, brackets	30 days	30 min

## IMPORTANT NOTES:

- A) All figures listed above are based on 8 hrs per day of operation, at ambient operating temperatures. Longer operation or higher temperatures will mean more frequent maintenance. Adhere to lubrication schedules in the final O and M manuals.
- B) The items and figures listed are estimates only. Actual time required will be dependent upon number and skill of personnel involved, working conditions, proper tool availability, amount of time for lockout / tag-out procedures and confined space entry procedures.
- C) The maintenance items listed above constitute a preliminary list, and it is not to be considered complete. Refer to the actual Operation and Maintenance Manuals that will be shipped with the final equipment. See Weekly list, pg 6-1, no downtime req'd.
- D) Fan information is not available at this time, as size of fan required is still unknown.

# Southern Environmental Sciences, Inc.

1204 North Wheeler Street □ Plant City, Florida 33563 □ (813) 752-5014 □ Fax: (813) 752-2475

## Dept. of Environmental Protection

May 25, 2007

MAY 29 2007

Mr. Danny Stubbs  
Air Permitting Engineer  
Florida Department of Environmental Protection  
13051 North Telecom Parkway  
Temple Terrace, FL 33637-0926

Southwest District

Re: Global Tire Recycling of Sumter County, Inc.  
Facility ID No. 1190028  
May 7, 2007 Request for Additional Information

Dear Mr. Stubbs,

In response to the above request I offer the following responses to help you in reviewing the permit application.

As stated on page 12 of the application the maximum projected annual production rate is 20,000 tons of mesh size crumb rubber beads. This number is based upon the original permit application for this source and has been included as a permit condition in all their past permits, hence it was included in this application as well. However, since increasing a maximum production rate of 26,280 TPY will not produce a substantial increase in potential emissions I have included several revised application pages to increase the annual maximum rate accordingly.

To avoid any more unnecessary delays in permit issuance please call me at 813-752-5014 if you have any additional questions.

Sincerely,



Rama Iyer, P.E.  
Permitting Manager

cc: Mark Bailey, – Global Tire Recycling

**Professional Engineer Certification**

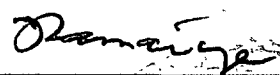
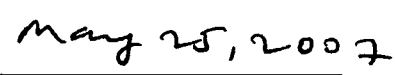
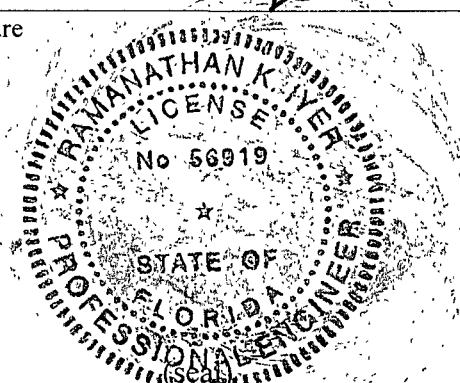
1. Professional Engineer Name: <b>RAMA IYER</b> Registration Number: <b>56919</b>
2. Professional Engineer Mailing Address: Organization/Firm: <b>SOUTHERN ENVIRONMENTAL SCIENCES, INC.</b> Street Address: <b>1204 NORTH WHEELER STREET</b> City: <b>PLANT CITY</b> State: <b>FL</b> Zip Code: <b>33563</b>
3. Professional Engineer Telephone Numbers: Telephone: <b>(813) 752-5014</b> Fax: <b>(813) 752-2475</b>
4. Professional Engineer Statement:  <i>I, the undersigned, hereby certify, except as particularly noted herein*, that:</i>  <i>(1) To the best of my knowledge, there is reasonable assurance that the air pollutant emissions unit(s) and the air pollution control equipment described in this Application for Air Permit, when properly operated and maintained, will comply with all applicable standards for control of air pollutant emissions found in the Florida Statutes and rules of the Department of Environmental Protection; and</i>  <i>(2) To the best of my knowledge, any emission estimates reported or relied on in this application are true, accurate, and complete and are either based upon reasonable techniques available for calculating emissions or, for emission estimates of hazardous air pollutants not regulated for an emissions unit addressed in this application, based solely upon the materials, information and calculations submitted with this application.</i>  <i>If the purpose of this application is to obtain an air construction permit for one or more proposed new or modified emissions units (check here [ <b>X</b> ], if so), I further certify that the engineering features of each such emissions unit described in this application have been designed or examined by me or individuals under my direct supervision and found to be in conformity with sound engineering principles applicable to the control of emissions of the air pollutants characterized in this application.</i>  <i>If the purpose of this application is to obtain an initial air operation permit or operation permit revision for one or more newly constructed or modified emissions units (check here [ <b>X</b> ], if so), I further certify that, with the exception of any changes detailed as part of this application, each such emissions unit has been constructed or modified in substantial accordance with the information given in the corresponding application for air construction permit and with all provisions contained in such permit.</i>  <div style="display: flex; justify-content: space-between;"><div style="text-align: center;"> _____ Signature</div><div style="text-align: center;"> _____ Date</div></div> <div style="text-align: center; margin-top: 20px;"></div> <div style="text-align: right; margin-top: 20px;">GLOBAL TRIE RECYCLING OF SUMTER COUNTY, INC. RESPONSE TO RAI DATED MAY 7, 2007</div>

\* Attach any exception to certification statement.

**Emissions Unit Control Equipment**

<p>4. Control Equipment/Method Description (limit to 200 characters per device or method):</p> <p><b>BAGHOUSE</b></p>
<p>2. Control Device or Method Code(s): <b>18</b></p>

**Emissions Unit Details**

<p>1. Package Unit:                  Manufacturer: <b>MAC ENVIRONMENTAL</b> Model Number: <b>144WMCF338</b></p>
<p>2. Generator Nameplate Rating: <b>MW</b></p>
<p>3. Incinerator Information:</p> <p style="text-align: right;">Dwell Temperature: °F</p> <p style="text-align: right;">Dwell Time: seconds</p> <p style="text-align: right;">Incinerator Afterburner Temperature: °F</p>

**Emissions Unit Operating Capacity and Schedule**

<p>1. Maximum Heat Input Rate: <b>mmBtu/hr</b></p>
<p>2. Maximum Incineration Rate: <b>lb/hr</b> <b>tons/day</b></p>
<p>3. Maximum Process or Throughput Rate: <b>29,000 LBS/HR, TIRE SHREDDING</b></p>
<p>4. Maximum Production Rate: <b>6000 LBS/HR MESH SIZE CRUMB RUBBER</b></p>
<p>5. Requested Maximum Operating Schedule:</p> <p style="text-align: right;">hours/day <b>days/week</b></p> <p style="text-align: right;">weeks/year <b>8760 hours/year</b></p>
<p>4. Operating Capacity/Schedule Comment (limit to 200 characters):  <b>Throughput Rate: is lbs/hr of whole passenger tire equivalents (WTEs)</b>  <b>Production Rate: is lbs/hr of mesh size crumb rubber.</b></p> <p><b>Max. Rates of individual Units: Shredder-14.5 tph, Primary Cracker Mill- 8 tph, Secondary Cracker Mill – 7 tph, Three Fine Grind Mills (total) – 3 tph, Air Separators – 8 tph</b></p> <p><b>The maximum annual production rate of crumb rubber is limited by the production rate of the 3 parallel fine grind mills.</b></p>



**C. SEGMENT (PROCESS/FUEL) INFORMATION**

**Segment Description and Rate:** Segment  1  of  1

1. Segment Description (Process/Fuel Type) (limit to 500 characters):  <b>WASTE DISPOSAL – SHREDDING, TIRES</b>		
4. Source Classification Code (SCC): <b>265000002</b>		3. SCC Units: <b>TONS PROCESSED</b>
5. Maximum Hourly Rate: <b>14.5</b>	4. Maximum Annual Rate: <b>26,280</b>	6. Estimated Annual Activity Factor:
7. Maximum % Sulfur:	8. Maximum % Ash:	9. Million Btu per SCC Unit:
10. Segment Comment (limit to 200 characters):  <b>Final product is clean granular sized rubber beads. The maximum annual production rate of crumb rubber is limited by the production rate of the 3 parallel fine grind mills.</b>		

**Segment Description and Rate:** Segment   of

1. Segment Description (Process/Fuel Type ) (limit to 500 characters):		
2. Source Classification Code (SCC):		3. SCC Units:
4. Maximum Hourly Rate:	5. Maximum Annual Rate:	6. Estimated Annual Activity Factor:
7. Maximum % Sulfur:	8. Maximum % Ash:	9. Million Btu per SCC Unit:
10. Segment Comment (limit to 200 characters):		

### D. EMISSIONS UNIT POLLUTANT DETAIL INFORMATION

#### Potential Emissions

1. Pollutant Emitted: <b>PM</b>		2. Pollutant Regulatory Code: <b>WP</b>	
3. Primary Control Device Code: <b>18</b>	4. Secondary Control Device Code:	5. Total Percent Efficiency of Control: <b>99.9</b>	
6. Potential Emissions: <div style="text-align: right; padding-right: 50px;"><b>.6 lb/hour</b></div> <div style="text-align: right;"><b>2.63 tons/year</b></div>		7. Synthetically Limited? [   ]	
8. Emission Factor:  Reference:		1) Emissions Method Code: <div style="text-align: center;"><b>2</b></div>	
1) Calculation of Emissions (limit to 600 characters):  $26,280 \text{ TPY} \times 5\% \text{ (cord \& fiber)} + 26,280 \text{ TPY} \times 5\% \text{ (rubber dust \& foreign material)} = 2,628 \text{ TPY to baghouse}$ $2628 \text{ TPY} \times (1 - .999) = \frac{2,628 \text{ TPY} \times 2000 \text{ lbs/ton}}{8760 \text{ hrs/yr}} = 0.6 \text{ lbs/hr}$			
1) Pollutant Potential Emissions Comment (limit to 200 characters): <b>Amount Entering Baghouse:</b> 1) Waste tire cord and tread (approx. 5% by weight of tires processed) 2) Rubber dust and foreign material (approx. 5% by weight of tires processed)			

**Allowable Emissions** Allowable Emissions NA of \_\_\_\_\_

1. Basis for Allowable Emissions Code:	2. Future Effective Date of Allowable Emissions:
3. Requested Allowable Emissions and Units:	4. Equivalent Allowable Emissions: <div style="text-align: right; padding-right: 50px;">lb/hour</div> <div style="text-align: right;">tons/year</div>
5. Method of Compliance (limit to 60 characters):	
6. Allowable Emissions Comment (Desc. of Operating Method) (limit to 200 characters):	