

Jeb Bush  
Governor

# Department of Environmental Protection

Southwest District  
13051 North Telecom Parkway  
Temple Terrace, FL 33637-0926  
Telephone: 813-632-7600

Colleen M. Castille  
Secretary

## NOTICE OF FINAL PERMIT

In the Matter of an  
Application for Permit by:

Mr. Kyle Garrett, Vice President  
Consolidated Minerals, Inc.  
1616 South 14<sup>th</sup> Street  
Leesburg, FL 34748

DEP File No. 1190018-012-AC  
Sumter County

Dear Mr. Garrett:

Enclosed is Final Permit Number 1190018-012-AC. This permit authorizes Consolidated Minerals, Inc. to modify a synthetic non-Title V limestone drying and process facility. This facility is located at State Road 48 West, Center Hill, Sumter County, Florida. This permit is issued pursuant to Section(s) 403.087, Florida Statutes.

Any party to this order has the right to seek judicial review of it under section 120.68 of the Florida Statutes, by filing a notice of appeal under Rule 9.110 of the Florida Rules of Appellate Procedure with the clerk of the Department of Environmental Protection in the Office of General Counsel, 3900 Commonwealth Boulevard, Mail Station #35, Tallahassee, Florida 32399-3000, and by filing a copy of the notice of appeal accompanied by the applicable filing fees with the appropriate District Court of Appeal. The notice must be filed within thirty days after this order is filed with the clerk of the Department.

Executed in Hillsborough County, Florida.

STATE OF FLORIDA DEPARTMENT  
OF ENVIRONMENTAL PROTECTION

*Mara Grace Nasca*

Mara Grace Nasca  
District Air Program Administrator  
Southwest District

MGN/JLM/pp

Enclosures

**CERTIFICATE OF SERVICE**

The undersigned duly designated deputy agency clerk hereby certifies that this Notice of Final Permit (including the Final Permit) was mailed by U.S. Mail before the close of business on 03-30-06 to the person(s) listed:

Mr. Kyle Garrett, Vice President  
Consolidated Minerals, Inc.  
1616 South 14<sup>th</sup> Street  
Leesburg, FL 34748

Mr. Steven C. Cullen, P.E.  
Koogler & Associates, Inc.  
4014 NW 13<sup>th</sup> Street  
Gainesville, FL 32609

Clerk Stamp

**FILING AND ACKNOWLEDGMENT FILED**, on this date, pursuant to §120.52, Florida Statutes, with the designated Department Clerk, receipt of which is hereby acknowledged.

  
(Clerk)

03-30-06  
(Date)



Jeb Bush  
Governor

# Department of Environmental Protection

Southwest District  
13051 North Telecom Parkway  
Temple Terrace, FL 33637-0926  
Telephone: 813-632-7600

Colleen M. Castille  
Secretary

## PROOF OF RECEIPT OF FINAL PERMIT DOCUMENTS FOR PROJECT NO. 1190018-012-AC

I, Kyle Garrett (Kyle Garrett, Vice President, Consolidated Minerals, Inc)  
acknowledge to have received and be in possession of the Final Permit documents pertaining to FDEP  
Project No. 1190018-012-AC. Such documents were hand delivered to me by authorized Department  
personnel on March 30<sup>th</sup>, 2006.

 3-30-06  
Company Authorized Representative/Date

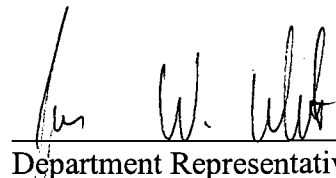
 3/30/06  
Department Representative/Date



Jeb Bush  
Governor

# Department of Environmental Protection

Southwest District  
13051 North Telecom Parkway  
Temple Terrace, FL 33637-0926  
Telephone: 813-632-7600

Colleen M. Castille  
Secretary

**PERMITTEE:**

Consolidated Minerals, Inc.  
1616 South 14<sup>th</sup> Street  
Leesburg, FL 34749-0180

**Final Permit No.:** 1190018-012-AC

**County:** Sumter

**Effective Date:** MAR 30 2006

**Expiration Date:** 12/15/2007

**Project:** Limestone Drying and  
Processing Facility

This permit is issued under the provisions of Chapter 403, Florida Statutes, and Florida Administrative Code Chapters 62-204, 62-210, 62-212, 62-213, 62-296, 62-297, and Chapter 62-4. The above named permittee is hereby authorized to perform the work or operate the facility shown on the application and approved drawing(s), plans, and other documents, attached hereto or on file with the department and made a part hereof and specifically described as follows:

This permit authorizes the construction modification of a synthetic non-Title V Limestone Drying and Processing Facility. The facility has synthetic particulate matter emission limitations and synthetic fuel oil usage limitations that keep the emissions of sulfur dioxide below the level, which would require a Title V permit. The modifications include the following:

- Increase the limestone hourly input rate of wet limestone to the dryer from 30 tons/hr. (based on a monthly average) to 35 tons/hr. based on a daily average.
- Increases the limestone annual input rate of wet limestone to the dryer from 262,800 tons per any consecutive 12-month period to 306,600 tons per any consecutive 12-month period.
- After-the-fact construction of Crusher No. 1 (CR-01) and Storage Silo No. 4 (SS-4).
- Venting emissions from some of the pieces of process equipment to a different dust collector.
- Adding 3 new emission units: 1) Fugitive Activities from the Enclosed Building; 2) Fugitive Activities from Outside the Enclosed Building; and 3) Truck Loading activities.
- Delete the requirement for the dust collector (DC-1) controlling emissions from the dryer to operate in accordance with an Operation and Maintenance Plan.
- Deleting a requirement for an Operation and Maintenance (O&M) Plan regarding the Sly, Inc., Model STJ-2817-12, baghouse (DC-1).

PERMITTEE:  
Consolidated Minerals, Inc.

FINAL PERMIT NO.: 1190018-012-AC  
PROJECT: Limestone Drying & Processing  
Facility

After the above modifications are completed the facility description will be as follows:

For the operation of a synthetic non-Title V Limestone Drying and Processing Facility to produce crushed stone meeting various specifications. Processing operations, in part, include hauling, drying, crushing, screening, conveying, stockpiling, and product handling. The facility has synthetic particulate matter emission limitations and synthetic fuel oil usage limitations that keep the emissions of sulfur dioxide below the level, which would require a Title V permit pursuant to Chapter 62-213, F.A.C. Some portions of the facility are subject to the New Source Performance Standards (NSPS) of Title 40 Code of Federal Regulations (CFR) Part 60, Subpart OOO – Standards of Performance for Nonmetallic Mineral Processing Plants. Below is a brief description of the emission units at the facility and the emission units are further described in the attached facility's process flow diagrams identified as CHMO35 1/3, CHMO35 2/3, and CHMO35 3/3, which were part of the permittee's application dated October 19, 2005.

#### **PERMITTED EMISSION UNITS**

##### Emission Unit No. 007 – Fugitive Emissions from Outside the Enclosed Building (NSPS & non-NSPS):

Wet limestone from a stockpile is transferred by front-end loader to Loading Hopper (LH-1) at a maximum rate of 120 tons/hr. From the Loading Hopper (LH-1) the wet limestone is transferred to a conveyor belt (BC-1). The conveyor belt (BC-1) then either transfers the limestone directly to Feed Bin (BN-1) or Crusher (CR-01). The conveyor belt (BC-1) cannot simultaneously transfer the limestone to the Feed Bin (BN-1) and Crusher (CR-01).

The activities associated with this emission unit are subject to the NSPS requirements of 40 CFR 60.672(b) and (c), except for the transfer of material from limestone stockpiles to the Loading Hopper (LH-1) by front-end loaders, which is subject to the General Visible Emissions Standard of Rule 62-296.320(4)(b), F.A.C.

##### Emission Unit No. 002 – Dryer (non-NSPS):

From the bottom of the Feed Bin (BN-1), which has its bottom portion inside a partially enclosed building, the wet limestone is transferred first to Feed Table (TF-1), which is part of Emission Unit No. 008 as described below. From the Feed Table the wet limestone is transferred to a dryer (DR-1) via a hopper at a maximum input rate of 35 tons/hr. based on a daily average. New No. 4 Fuel Oil (or better grade) or natural gas is used to fire the dryer at a maximum heat input rate of 85 MMBTU/hr. The maximum sulfur content of the fuel oil is 0.50% by weight. Liquefied Petroleum Gas (Propane) is used as an ignition fuel for startup of the dryer. For each ignition attempt, propane is ignited at a rate of 250,000 BTU/hour for a maximum of 20 seconds.

Emissions from the dryer are controlled by a Sly, Inc., Model STJ-2817-12, baghouse designated as DC-1 with a design airflow rate of 35,000 acfm. The baghouse's captured particulate is transferred to Storage Silo SS-3, which is part of Emission Unit No. 005 and described below.

PERMITTEE:  
Consolidated Minerals, Inc.

FINAL PERMIT NO.: 1190018-012-AC  
PROJECT: Limestone Drying & Processing  
Facility

As requested by the permittee in the application dated August 9, 2005, the requested maximum allowable particulate emissions from the dryer are stricter than Rule 62-296.320(4)(a), F.A.C. – Process Weight Table. Since the nature of this process does not allow the dryer to operate below the process input rate of 2.2 tons/hr., which is where the allowable emissions from the process weight table would be more stringent than the permittee's requested emission limitations, Rule 62-296.320(4)(a), F.A.C. is considered not applicable. Visible emissions from the dryer are subject to Rule 62-296.320(4)(b), F.A.C. – General Visible Emissions Standard.

Based on the permittee's requested particulate matter emission limitation and fuel oil usage limitation to avoid the Title V permitting requirements of Chapter 62-213, F.A.C., emissions of the pollutants particulate matter and sulfur dioxide emissions are considered synthetically limited.

Emission Unit No. 003 – Screening (NSPS) (w/Truck Loading & optional Milling – see descriptions below):

Dried limestone from the dryer (DR-1), along with oversized material from the shaker screen (SN-1) that is screw conveyed (SC-3) and crushed via crusher (CR-02), are placed on a screw conveyor (SC-2). Screw conveyor (SC-2) deposits the material into a bucket elevator (BE-1). The bucket elevator (BE-1) then delivers the material to the shaker screen (SN-1).

The shaker screen (SN-1) is a triple-deck screening system. Oversized material that does not pass through the first screen from the shaker screen (SN-1) either goes to a screw conveyor (SC-3) and gets crushed via crusher (CR-02) or is stored in a feed bin (BN-2). If the oversized material is sent to the crusher, it gets sent back to the shaker screen (SN-1) via a screw conveyor (SC-2) and bucket elevator (BE-1). If the oversized material is sent to the feed bin (BN-2), then the material is fed to a belt conveyor (BC-3) and conveyed to a rotary feeder (VF-1) for the mill (RM-1) (a.k.a., Raymond Mill) & cyclonic air/product separator (CY-1). The mill (RM-1) and a cyclonic air/product separator (CY-1) are designated as Emission Unit No. 004 and described below.

Material that does not pass the second screen of the shaker screen (SN-1) is either deposited in a feed bin (BN-2) with some of the oversized material or deposited on a belt conveyor (BC-4). If this material is deposited into the feed bin (BN-2), then the material is fed to a belt conveyor (BC-3) and conveyed to a rotary feeder (VF-1) for the mill. If the material is deposited onto a belt conveyor (BC-4), then it is dropped into a bucket elevator (BE-2), which deposits the material into a storage silo (SS-1) for truck load out. Storage silo SS-1 and 3 additional storage silos (SS-2, SS-3, SS-4) are designated as Emission Unit No. 005 and the truck loading activities are designated as Emission Unit No. 006, which are both described below.

PERMITTEE:  
Consolidated Minerals, Inc.

FINAL PERMIT NO.: 1190018-012-AC  
PROJECT: Limestone Drying & Processing  
Facility

Material that does not pass the third screen of the shaker screen (SN-1) is deposited into the product line (LL-3) and blown (BL-5) into a storage silo (SS-4) for truck load out (LS-1) or can also go to the feed bin (BN-2).

Material that passes all three screens of the shaker screen (SN-1) is deposited into the feed bin (BN-2) and fed to a belt conveyor (BC-3) and conveyed to a rotary feeder (VF-1).

Particulate matter emissions from the screw conveyor (SC-2), bucket elevators (BE-1 & BE-2), belt conveyors (BC-3 and BC-4), feed bin (BN-2), and shaker screen (SN-1) are captured by a dust collector (DC-2).

Dust collector (DC-2) is a Sly, Inc., Model STJ-1315-10, baghouse with a design airflow rate of 12,800 acfm. The baghouse's captured particulate matter is transferred to Storage Silo SS-3, which is part of Emission Unit No. 005 and described below. Note, the mill (RM-1) & cyclonic air/product separator (CY-1) are mentioned with Emission Unit No. 003, since their emissions may be vented to baghouse DC-2 and/or baghouse DC-3. Emissions from the truck loading activities are also controlled by baghouse DC-2.

When any of the activities controlled by baghouse DC-2 are operating, even if the Screening, Truck Loading, and Rotary Mill & Cyclonic air/product separator are each operating alone, the emissions from baghouse DC-2 are subject to the emissions limitations of 40 CFR 60.672(a).

Emission Unit No. 004 – Milling (non-NSPS):

Dried limestone from a feed bin (BN-2) is transferred by a belt conveyor (BC-3) and then to a variable speed rotary feeder (VF-1). The rotary feeder feeds a non-NSPS mill (a.k.a. Raymond Mill) (RM-1) at an approximate maximum process input rate of 29.4 tons/hr. from the dryer based on a daily average (35 x 0.84). Limestone from the mill (RM-1) is then transferred to a cyclonic air/product separator (CY-1). Air from the cyclonic air/product separator (CY-1) is routed back to the mill (RM-1), baghouse DC-2, and/or baghouse DC-3.

Baghouse DC-3 is a Sly, Inc., Model STJ-78-10, with a design airflow rate of 4,000 acfm. As mentioned in Emission Unit No. 003 above, the emissions from both of these pieces of equipment (Mill & Cyclonic air/product separator) is vented out the cyclonic air/product separator to baghouse DC-2 and/or DC-3. The baghouse DC-3's captured particulate matter and product from the cyclonic air/product separator are transferred by a common enclosed pipe to Storage Silo SS-2 or Storage Silo SS-3, but not to both silos simultaneously.

PERMITTEE:  
Consolidated Minerals, Inc.

FINAL PERMIT NO.: 1190018-012-AC  
PROJECT: Limestone Drying & Processing  
Facility

The permittee has requested maximum allowable particulate emissions from baghouse DC-3 that are stricter than Rule 62-296.320(4)(a), F.A.C. – Process Rate Table. Since the nature of this process does not allow the mill to operate below the process input rate of 0.17 tons/hr., which is where the allowable emissions from the process weight table would be more stringent than the permittee's requested emission limitations, Rule 62-296.320(4)(a), F.A.C. is considered not applicable. Visible emissions from baghouse DC-3 are subject to Rule 62-296.320(4)(b), F.A.C. – General Visible Emissions Standard.

Based on the permittee's requested particulate matter emission limitation to avoid the Title V permitting requirements of Chapter 62-213, F.A.C., emissions of the pollutant particulate matter is considered synthetically limited.

Emission Unit No. 005 – Four (4) Storage Silos (NSPS):

This emission unit consists of four (4) limestone storage silos and other miscellaneous activities as described below. The silos are designated Storage Silos SS-1 (west), SS-2 (middle), SS-3 (east), and SS-4 (south). All four silos are controlled by a common Sly, Inc., Model STJ-88-10, baghouse with a design airflow rate of 6,000 acfm. This baghouse is designated as baghouse DC-4. Storage Silos SS-1, SS-2, and SS-3 are of similar size and were constructed prior to the applicability date of August 31, 1983, for the New Source Performance Standards (NSPS) of 40 CFR 60, Subpart OOO – Standards of Performance for Nonmetallic Mineral Processing Plants. Storage Silo SS-4, which has a smaller storage capacity than the other three (3) storage silos, is subject to the requirements of the New Source Performance Standards (NSPS) of 40 CFR 60, Subpart OOO – Standards of Performance for Nonmetallic Mineral Processing Plants and is located on the south side of Silo SS-2.

**Storage Silo SS-1 (west):** This silo only receives dried and screened limestone from Bucket Elevator (BE-2) at an approximate maximum filling rate of 3.85 tons/hr. (35 x 0.11). The emissions during the filling of the silo are vented to Storage Silo SS-2, which then vents to Storage Silo SS-3.

**Storage Silo SS-2 (middle):** This silo receives dried and screened limestone that has passed through the cyclonic air/product separator (CY-1) at an approximate maximum filling rate of 29.4 tons/hr. (35 x 0.84) along with captured particulate from baghouse DC-3. The emissions during the filling of this silo are vented to Storage Silo SS-3.

**Storage Silo SS-3 (east):** This silo receives dried and screened limestone that has passed through the cyclonic air/product separator (CY-1) at an approximate maximum filling rate of 29.4 tons/hr. (35 x 0.84) along with following:

- Captured particulates from baghouses DC-1, DC-2, DC-3 and DC-4; and
- Emissions during the filling of Storage Silos SS-1, SS-2, and SS-4.



PERMITTEE:  
Consolidated Minerals, Inc.

FINAL PERMIT NO.: 1190018-012-AC  
PROJECT: Limestone Drying & Processing  
Facility

**Storage Silo SS-4 (south):** This silo only receives dried and screened limestone from the Shaker Screener (SN-1) at an approximate maximum filling rate of 1.75 tons/hr. (35 x 0.05). The emissions during the filling of the silo are vented to Storage Silo SS-2, which then vents to Storage Silo SS-3.

All the activities associated with this emission unit and the emissions from baghouse DC-4 are at all times subject to the particulate matter and visible emission limitations of 40 CFR 60.672(g). Note, 40 CFR 60.672(g) refers to the limitations in 40 CFR 60.672(a).

Emission Unit No. 006 – Truck Loading Operations (NSPS):

Dried Limestone (product) from Storage Silos SS-1, SS-2, SS-3, and SS-4 is transferred to a truck loading station where only 1 truck at any one time may be loaded. Trucks are loaded at the maximum loading rate of 108 tons/hr. (based on the actual filling time of the truck divided by the actual loading time of the truck).

Emissions from loading the trucks are controlled by a Sly, Inc., Model STJ-1315-10, baghouse designated as DC-2 with a design airflow rate of 12,800 acfm. The baghouse's captured particulate matter is transferred to Storage Silo SS-3, which is part of Emission Unit No. 005 and described above. This baghouse also controls emissions from Emission Unit Nos. 003 and 004 as described above.

As mentioned in Emission Unit No. 003 above, when any of the activities controlled by baghouse DC-2 are operating, even if the Screening, Truck Loading, and Rotary Mill & Cyclonic air/product separator are each operating alone, the emissions from baghouse DC-2 are subject to the emissions limitations of 40 CFR 60.672(a).

During the loading of trucks, "dust oil" may be added to the granular product from only storage silo SS-1 at an approximately rate of 0.75 lbs. per ton of product loaded.

Emission Unit No. 008 – Fugitive Emissions from Inside the Enclosed Building (NSPS):

This emission unit consists of fugitive source emissions from inside an enclosed building. Although the building is able to operate in an enclosed configuration, the facility normally operates with various garage door size type openings in the open position. Fugitive sources inside the building include the Crusher (CR-02), Feed Bin (BN-1) to the Feed Table (TF-1), belt conveyor (BC-3), and belt conveyor (BC-4).

Emissions from the fugitive sources are subject to 40 CFR 60.672(e)(1).

PERMITTEE:  
Consolidated Minerals, Inc.

FINAL PERMIT NO.: 1190018-012-AC  
PROJECT: Limestone Drying & Processing  
Facility

Exempt Emission Source(s):

The emissions from the following emission sources at this facility are deemed insignificant and exempt from permitting:

- Fuel Oil Tank, pursuant to Rule 62-210.300(3)(b)1., F.A.C.

Facility Information Summary

**Location:** State Road 48 West, Center Hill

**UTM Coordinates:** 17-401.50E 3169.50N

**Latitude:** 28°39'20" North

**Longitude:** 82°00'35" West

**Facility ID No.:** 1190018

**Emission Unit No.:**

- 002 – Dryer
- 003 – Screening (w/Truck Loading & optional Milling)
- 004 – Milling
- 005 – Four Storage Silos
- 006 – Truck Loading Operations
- 007 – Fugitive Emissions from Outside the Enclosed Building
- 008 – Fugitive Emissions from Inside the Enclosed Building

**NOTE:** Please reference the Permit No., Facility ID, and Emission Unit ID in all correspondence, test report submittals, applications, etc.

Permit History

Modifies Permit Nos.: 1190018-003-AC and 1190018-008-AO

Attachments to this permit:

- General Conditions, version dated 11/1/2005
- ATTACHMENT NSPS - New Source Performance Standards (NSPS) of Title 40 Code of Federal Regulations (CFR) Part 60, Subpart OOO - Standards of Performance for Nonmetallic Mineral Processing Plants
- GENERAL PROVISIONS – Title 40 Code of Federal Regulations, Subpart A
- Process Flow Diagrams - CHMO35 1/3, CHMO35 2/3, and CHMO35 3/3

PERMITTEE:  
Consolidated Minerals, Inc.

FINAL PERMIT NO.: 1190018-012-AC  
PROJECT: Limestone Drying & Processing  
Facility

**SPECIFIC CONDITIONS:**

The following conditions apply facility-wide:

1. General Conditions: A part of this permit is the attached 15 General Conditions.  
[Rule 62-4.160, F.A.C.]
2. Other Requirements: Issuance of this permit does not relieve the permittee from complying with the applicable emission limiting standards or other requirements of Chapters 62-204, 62-210, 62-212, 62-213, 62-296, and 62-297, F.A.C. or any other requirement under federal, state, or local law.  
[Rule 62-210.300, F.A.C.]
3. General Visible Emission Limitation: Except for emissions units that are subject to a particulate matter or opacity limit set forth or established by rule and reflected by conditions in this permit, no person shall cause, let, permit, suffer or allow to be discharged into the atmosphere the emissions of air pollutants from any activity, the density of which is equal to or greater than that designated as Number 1 on the Ringelmann Chart (20 percent opacity). EPA Method 9 is the method of compliance pursuant to Chapter 62-297, F.A.C.  
[Rules 62-296.320(4)(b)1. & 4., F.A.C.]
4. Hours of Operation: The emission units/activities at this facility are permitted to operate continuously, 8,760 hours/year.  
[Rule 62-210.200(PTE), F.A.C.]
5. Reasonable Precautions for Unconfined Emissions of Particulate Matter: No person shall cause, let, permit, suffer or allow the emissions of unconfined particulate matter from any activity, including vehicular movement; transportation of materials; construction, alteration, demolition or wrecking; or industrially related activities such as loading, unloading, storing and handling. Reasonable precautions include the following:
  - A. Paving and maintenance of roads, parking areas and yards.
  - B. Application of water or chemicals to control emissions from such activities as demolition of buildings, grading roads, construction, and land clearing.
  - C. Application of asphalt, water, oil, chemicals or other dust suppressants to unpaved roads, yards, open stock piles and similar emission units.
  - D. Removal of particulate matter from roads and other paved areas under the control of the permittee of the emissions unit to prevent re-entrainment, and from buildings or work areas to prevent particulate matter from becoming airborne.

PERMITTEE:  
Consolidated Minerals, Inc.

FINAL PERMIT NO.: 1190018-012-AC  
PROJECT: Limestone Drying & Processing  
Facility

- E. Landscaping or planting of vegetation.
- F. Use of hoods, fans, filters, and similar equipment to contain, capture and/or vent particulate matter.
- G. Confining abrasive blasting where possible.
- H. Enclosure or covering of conveyor systems.

[Rules 62-296.320(4)(c)1. and 3., F.A.C.]

6. Reasonable Assurance: In order to provide reasonable assurance that the precautions and practices required in Specific Condition No. 5 are adequate, emissions of unconfined particulate matter from the non-process emission sources shall not exceed 10 percent opacity. Exceedance of this limit shall not be considered a violation in and of itself, but an indication that additional control precautions and/or practices may be necessary.

[Rule 62-4.070(3), F.A.C.]

7. Recordkeeping Requirements: Daily records required by this permit shall be completed within 5 business days and monthly records shall be completed by the 15<sup>th</sup> day of the following month. All records required by this permit shall be maintained at the facility for a period of two (2) years following the date of such record and made available to the Department upon request.

[Rule 62-4.070(3), F.A.C. and 40 CFR 60.7(f)]

8. Excess Emissions: Excess emissions resulting from startup, shutdown, or malfunction are permitted providing: (1) best operational practices to minimize emissions are adhered to and; (2) the duration of excess emissions shall be minimized but in no case exceed two hours in any 24 hour period unless specifically authorized by the Department for longer duration. Excess emissions which are caused entirely or in part by poor maintenance, poor operation, or any other equipment or process failure which may reasonably be prevented during startup, shutdown, or malfunction shall be prohibited. In case of excess emissions resulting from malfunctions, the permittee shall notify the Department in accordance with Rule 62-4.130, F.A.C. A full written report on the malfunctions shall be submitted in a quarterly report, if requested by the Department.

{Permitting Note: This rule cannot vary any requirement of an applicable NSPS or NESHAP provision.}

[Rule 62-210.700, F.A.C.]

PERMITTEE:  
Consolidated Minerals, Inc.

FINAL PERMIT NO.: 1190018-012-AC  
PROJECT: Limestone Drying & Processing  
Facility

9. Special Testing Requirement: When the Department, after investigation, has good reason (such as complaints, increased visible emissions or questionable maintenance of control equipment) to believe that any applicable emission standard contained in a Department rule or in a permit issued pursuant to those rules is being violated, it shall require the owner or operator of the emissions unit to conduct compliance tests which identify the nature and quantity of pollutant emissions from the emissions unit and to provide a report on the results of the said tests to the Department.

[Rule 62-297.310(7)(b), F.A.C.]

10. Annual Operating Report Requirement: Submit to the Air Compliance Section of this office each calendar year on or before March 1, completed DEP Form 62-210.900(5), "Annual Operating Report for Air Pollutant Emitting Facility," for the preceding calendar year. The report may be submitted electronically in accordance with the instructions received with the AOR package sent by the Department, or a hardcopy may be submitted.

[Rule 62-210.370(3)(a)2., F.A.C.]

11. Operating Permit Application Revision: The permittee's previously submitted electronic air pollution application (DEP File No. 1190018-011-AO) to renew permit 1190018-008-AO is currently incomplete. As requested in the Department's letter June 7, 2005, the permittee shall re-submit to the Air Permitting Section of this office a revised electronic renewal application no later than 105 days after the effective date of this permit along with the following:

- A. Additional processing fees, if applicable.
- B. Test Reports as required by Specific Condition Nos. A.7., B.11., C.9., D.9, E.9., F.10., and G.6., if not previously submitted.

[Rules 62-4.050, 62-62-297.310(7), 62-210.300(2), and 62-4.090, F.A.C.]

The following conditions apply to the Fugitive Emissions from Outside the Enclosed Building (NSPS & non-NSPS) - Emission Unit No. 007:

A.1. Permitted Capacity: The maximum transfer rate of wet limestone is 120 tons/hr.

[Rule 62-210.200(PTE), F.A.C.]

A.2. Operational Limitations: The conveyor belt (BC-1) either transfers the limestone directly to Feed Bin (BN-1) or Crusher (CR-01). The conveyor belt (BC-1) cannot simultaneously transfer the limestone to the Feed Bin (BN-1) and Crusher (CR-01).

[Rule 62-210.200(PTE), F.A.C.]

PERMITTEE:  
Consolidated Minerals, Inc.

FINAL PERMIT NO.: 1190018-012-AC  
PROJECT: Limestone Drying & Processing  
Facility

A.3. Visible Emissions Limitations: The fugitive emissions from the emission points are limited as follows:

Emission Point No.	Brief Description	Max.VE Limit (% Opacity)
1	Material from outdoor storage pile(s) transferred by front-end loader(s) to Loading Hopper (LH-1)	<20*
2	Loading Hopper (LH-1) to Conveyor Belt (BC-1)	10**
3	Conveyor Belt (BC-1) to Feed Bin (BN-1)	10**
4	Conveyor Belt (BC-1) to Crusher (CR-01)	15***
5	Crusher (CR-01) to Feed Bin (BN-1)	10**

[Rule 62-296.320(4)(b), F.A.C.\* and 40 CFR 60.672(b)\*\* and (c)\*\*\*]

A.4. Recordkeeping Requirements: The permittee at a minimum shall record the following:

- A. If all of the most recent required visible emission tests were conducted within 90-100% of the maximum transfer rate of 120 tons/hr., the permittee shall only be required to determine and record the actual transfer rate during the test period.
- B. If any of the most recent required visible emission tests were conducted below 90% of the maximum transfer rate of 120 tons/hr., the permittee shall be required to **DAILY** determine and record the "actual daily average transfer rate" until all of the required visible emission tests are subsequently conducted within 90-100% of maximum transfer rate of 120 tons/hr.

MONTHLY

- C. The total hours of transferring wet limestone.
- D. The most recent consecutive 12-month period total hours of transferring wet limestone.
- E. The records required below to document the dryer's (Emission Unit No. 002) wet limestone process input rate shall be used to also document the amount of material (throughput) for this emission unit, in order to complete the Annual Operating Report required pursuant to Rule 62-210.370, F.A.C.

[Rule 62-4.070(3), F.A.C.]

PERMITTEE:  
Consolidated Minerals, Inc.

FINAL PERMIT NO.: 1190018-012-AC  
PROJECT: Limestone Drying & Processing  
Facility

A.5. Visible Emission Test Frequency Requirements: Emission Point Nos. 2, 3, 4, and 5 shall **each** be initially tested for visible emissions within 60 days after the effective date of this permit and annually thereafter during each federal fiscal year (October 1 – September 30). {Permitting Note: Visible emission testing for Emission Point No. 1 is not required to conduct regular scheduled testing, since the applicable visible emission limitation is a facility-wide limitation and there is no applicable allowable mass emission limitation.}

[Rule 62-297.310(7), F.A.C.]

A.6. Visible Emission Testing Requirement: Visible emission testing shall comply with the following:

- A. Testing shall be conducted when wet limestone is being transferred to feed bin (BN-1) within 90-100% of the maximum transfer rate of 120 tons/hr. A compliance test conducted at a transfer rate less than 90% of the maximum permitted transfer rate will automatically constitute an amended permitted rate at the lesser rate plus 10%. If the lesser amended rate is exceeded, then within 30 days of operating at that higher rate, a new visible emission test shall be conducted at no less than that higher rate, but not greater than 120 tons/hr. The test report shall be submitted to the Air Compliance Section of this office within 45 days of testing. Acceptance of the test report by the Department shall constitute an amended maximum transfer rate at the higher tested rate plus 10%. Failure to include with any test report the records required by Specific Condition No. A.4.A. or B. (as appropriate) for the test day, may invalidate the test.
- B. Each visible emission test shall be conducted in accordance with EPA Method 9, contained in 40 CFR 60, Appendix A, which is adopted and incorporated by reference in Rule 62-204.800(8), F.A.C. [40 CFR 60.675(c)(1)]
- C. The minimum distance between the observer and the emission source shall be 15 feet. [40 CFR 60.675(c)(1)(i)]
- D. The observer shall, when possible, select a position that minimizes interference from other fugitive emission sources (e.g., road dust). The required observer position relative to the sun (Method 9, Section 2.1) must be followed. [40 CFR 60.675(c)(1)(ii)]
- E. Regarding the initial visible emission tests:
  - 1. Emission Point Nos. 2, 3, and 5: The duration of each visible emission test may be reduced from 3 hours (thirty 6-minute averages) to 1 hour (ten 6-minute averages) only if the following conditions apply:
    - a. There are no individual readings greater than 10 percent opacity; and
    - b. There are no more than 3 readings of 10 percent for the 1-hour period.

[40 CFR 60.675(c)(3)]

PERMITTEE:  
Consolidated Minerals, Inc.

FINAL PERMIT NO.: 1190018-012-AC  
PROJECT: Limestone Drying & Processing  
Facility

2. Emission Point No. 4: The duration of the test visible emission test may be reduced from 3 hours (thirty 6-minute averages) to 1 hour (ten 6-minute averages) only if the following conditions apply:
  - a. There are not individual readings greater than 15 percent opacity; and
  - b. There are no more than 3 readings of 15 percent for the 1-hour period.

[40 CFR 60.675(c)(4)]

- F. Regarding visible emission testing after the initial tests: Each subsequent annual visible emission test shall be at least 30 minutes in duration. [Rule 62-297.310(4), F.A.C.]
- G. If emissions from two or more of Emission Point Nos. 2, 3, 4, and 5 cannot be read, either of the following procedures may be used:
  1. Use for the combined emission stream the highest fugitive opacity standard applicable to any of the emission points contributing to the emission stream.
  2. Separate the emissions so that the opacity of emissions from each emission point can be read.

[40 CFR 60.675(e)(1)]

[Rules 62-204.800(8), 62-297.310(4) and 62-297.401, F.A.C.]

A.7. Test Report Requirements: Visible emission test reports shall be submitted to the Air Compliance Section of this office within 45 days of testing.  
[Rule 62-297.310(8), F.A.C.]

A.8. Test Notifications: The permittee shall comply with the following:

- A. For each initial visible emission tests: The permittee shall notify the Air Compliance Section of this office at least 30 days prior to the test date on which each formal compliance test is to begin, of the date, time, and place of each such test, and the test contact person who will be responsible for coordinating and having such test conducted for the owner or operator.
- B. For each annual visible emission test after the initial test: The permittee shall notify the Air Compliance Section of this office at least 15 days prior to the test date on which each formal compliance test is to begin, of the date, time, and place of each such test, and the test contact person who will be responsible for coordinating and having such test conducted for the owner or operator.

[40 CFR 60.7(a)(6) and Rule 62-297.310(7)(a)9., F.A.C.]



PERMITTEE:  
Consolidated Minerals, Inc.

FINAL PERMIT NO.: 1190018-012-AC  
PROJECT: Limestone Drying & Processing  
Facility

The following conditions apply to the Dryer (non-NSPS) - Emission Unit No. 002:

B.1. Permitted Capacity: The wet limestone process input rate to the dryer shall not exceed the following:

- A. 35 tons/hr. based on a daily average.
- B. 306,600 tons per any consecutive 12-month period.

[Rule 62-210.200 (PTE), F.A.C.]

B.2. Methods of Operation: The dryer is fired with the following fuels:

- A. New No. 4 fuel oil or better grade (new Nos. 1, 2, or 3 fuel oils).
- B. Natural gas.
- C. Liquid Petroleum Gas (Propane) may be used as an ignition fuel for startup of the dryer. For each ignition attempt, propane is ignited at a rate of approximately 250,000 BTU/hr. for a maximum of 20 seconds.

[Rule 62-210.200(PTE), F.A.C.]

B.3. Operational Limitations: The dryer shall comply with the following:

- A. The dryer shall be fired with new fuel oil or natural gas at a maximum heat input rate of 85 MMBTU/hr. based on a monthly average. (Permitting Note: This equates to a maximum fuel oil usage rate of 582 gallons/hr. based on the heat content value of 146,000 BTU's per gallon of fuel oil and 0.081 MMcf/hr. of natural gas based on the heat content value of 1050 MMBTU/MMcf.)
- B. In order to synthetically limit the sulfur dioxide emissions below the Title V permitting requirements of Chapter 62-213, F.A.C., the new fuel oil for the dryer:
  - 1. Shall have a maximum sulfur content of 0.50% by weight at all times including periods of startup, shutdown, and malfunctions.
  - 2. Shall not exceed a usage rate of 2,620,000 gallons per any consecutive 12-month period.

{Permitting Note: These limitations equate to maximum sulfur dioxide emissions of 43.65 lbs./hr. and 98.25 tons/yr.}

[Rule 62-210.200(PTE), F.A.C.; Requested by permittee in application dated October 19, 2005]

PERMITTEE:  
Consolidated Minerals, Inc.

FINAL PERMIT NO.: 1190018-012-AC  
PROJECT: Limestone Drying & Processing  
Facility

B.4. Particulate Matter Emission Limitations: Particulate matter emissions from the dryer's baghouse (DC-1) shall not exceed the following:

- A. 0.04 gr/dscf
- B. 5.84 lbs./hr.
- C. 25.6 tons/yr.

The maximum allowable particulate emissions from the dryer are stricter than Rule 62-296.320(4)(a), F.A.C. – Process Weight Table. Since the nature of this process does not allow the dryer to operate below the process input rate of 2.2 tons/hr., which is where the allowable emissions from the process weight table would be more stringent than these emission limitations, Rule 62-296.320(4)(a), F.A.C. is considered not applicable.

[Rule 62-210.200(PTE), F.A.C.; Requested by permittee in application dated August 9, 2005]

B.5. Visible Emissions Limitation: Visible emissions from the dryer's baghouse (DC-1) shall not be equal to or exceed 20% opacity.

[Rule 62-296.320(4)(b), F.A.C.]

B.6. Recordkeeping Requirements: The permittee at a minimum shall record the following:

#### DAILY

- A. The hours of transferring wet limestone to the dryer.
- B. The amount of wet limestone transferred to the dryer in tons.
- C. The daily average wet limestone transfer rate to the dryer in tons/hr.
- D. The pressure drop across baghouse (DC-1) in inches of water.

#### MONTHLY

- E. The total hours of transferring wet limestone to the dryer.
- F. The most recent consecutive 12-month period total hours of transferring wet limestone to the dryer.
- G. The total amount of wet limestone transferred to the dryer in tons.
- H. The most recent consecutive 12-month period total tons of wet limestone transferred to the dryer.

PERMITTEE:  
Consolidated Minerals, Inc.

FINAL PERMIT NO.: 1190018-012-AC  
PROJECT: Limestone Drying & Processing  
Facility

- I. The total amount of fuel oil used to fire the dryer in gallons.
- J. The most recent consecutive 12-month period total gallons of fuel oil used to fire the dryer.
- K. The total amount of natural gas used to fire the dryer in cubic feet.
- L. The most recent consecutive 12-month period total cubic feet of natural gas used to fire the dryer.
- M. The most recent consecutive 12-month period total gallons of propane received to fire the dryer.
- N. The total monthly average heat input rate of fuel oil and natural gas to the dryer in MMBTU/hr.

[Rule 62-4.070(3), F.A.C.]

**B.7. Fuel Oil Sulfur Content Determination:** The permittee shall for each tanker truck delivery of new fuel oil have a vendor's supplied certification that the fuel oil delivered does not exceed a maximum sulfur content of 0.50% by weight. The certification shall include the following:

- A. The date of receipt.
- B. The name of the oil supplier.
- C. The Grade of fuel oil (i.e., No. 3, No. 4, etc.)
- D. The quantity of fuel oil delivered in gallons.
- E. The percent (%) of sulfur by weight of the fuel oil delivered.
- F. The test method used to determine the sulfur content of the fuel oil (i.e., ASTM Method D4057-88, D129-91, D2622-94, or D4294-90, which are adopted and incorporated by reference in Rule 62-297.440(1), F.A.C.).

[Rules 62-4.070(3) and 62-297.440(1), F.A.C.]

PERMITTEE:  
Consolidated Minerals, Inc.

FINAL PERMIT NO.: 1190018-012-AC  
PROJECT: Limestone Drying & Processing  
Facility

B.8. Particulate and Visible Emission Test Frequency Requirements: The dryer's baghouse (DC-1) emissions shall be tested for particulate matter and visible emissions within 60 days after the effective date of this permit and annually thereafter during each federal fiscal year (October 1 – September 30). Annual compliance testing for particulate matter shall not be required for any fuel burning emissions unit that, in a federal fiscal year, does not burn liquid and/or solid fuel, other than during startup, for a total of more than 400 hours.  
[Rule 62-297.310(7), F.A.C.]

B.9. Test Method Requirements: Testing of emissions from the dryer's baghouse (DC-1) shall be in accordance with the following test methods:

- A. EPA Method Nos. 1, 2, 3, 4, and 5 for particulate matter emissions.
- B. EPA Method No. 9 for visible emissions. The observation period shall be at least 30 minutes in duration.

The test methods are contained in 40 CFR 60, Appendix A, which is adopted and incorporated by reference in Rule 62-204.800(8), F.A.C.  
[Rules 62-297.310(4) and 62-297.401, F.A.C.; 40 CFR 60, Appendix A]

B.10. Operating Rate During Testing Requirements: Testing of emissions shall be conducted in accordance with the following:

- A. When the wet limestone input rate to the dryer is within 90-100% of the permitted capacity of 35 tons/hr. If it is impractical to test at the permitted capacity, an emission unit may be tested at less than the maximum permitted capacity; in this case, subsequent emissions unit operation is limited to 110% of the tested input rate until a new test is conducted. Once the unit is so limited, operation at higher capacities is allowed for no more than 15 consecutive days for the purpose of additional compliance testing to regain the authority to operate up to the maximum permitted capacity.
- B. If the most recent emission compliance test was conducted when the dryer was fired with natural gas or propane, a new test shall be conducted within 30 days of the dryer exceeding the 400<sup>th</sup> hour of firing the dryer on fuel oil. The new test shall be conducted with the dryer being fired with fuel oil. The permittee is responsible to keep adequate records in order to determine when such testing would be required.

[Rules 62-297.310(2) and 62-297.310(7)(a)5., F.A.C.]

PERMITTEE:  
Consolidated Minerals, Inc.

FINAL PERMIT NO.: 1190018-012-AC  
PROJECT: Limestone Drying & Processing  
Facility

B.11. Test Report Requirements: Test reports shall be submitted to the Air Compliance Section of this office within 45 days of testing. Be sure to attach to each test report:

- A. A statement of the dryer's actual wet process input rate for the test day in tons/hr.
- B. A copy of the daily records for the test day.
- C. A copy of the monthly records for the month the dryer was tested.

[Rules 62-4.070(3) and 62-297.310(8), F.A.C.]

B.12. Test Notifications: The permittee shall notify the Air Compliance Section of this office at least 15 days prior to the test date on which each formal compliance test is to begin, of the date, time, and place of each such test, and the test contact person who will be responsible for coordinating and having such test conducted for the owner or operator.

[Rule 62-297.310(7)(a)9, F.A.C.]

B.13. Circumvention: The permittee shall not circumvent any air pollution control device, or allow the emission of air pollutants without the applicable air pollution control device operating properly.

[Rule 62-210.650, F.A.C.]

The following conditions apply to Screening (NSPS) - Emission Unit No. 003:

C.1. Permitted Capacity: The processing rate of dried limestone for the screening operations shall be considered the same as the dryer's wet limestone process input rate. The wet limestone process input rate to the dryer shall not exceed the following:

- A. 35 tons/hr. based on a daily average.
- B. 306,600 tons per any consecutive 12-month period.

{Permitting Note: The approximate maximum process input rate to the screening activities is 30.8 tons/hr. from the dryer based on a daily average (35 x 0.88).}

[Rule 62-210.200 (PTE), F.A.C.]

PERMITTEE:  
Consolidated Minerals, Inc.

FINAL PERMIT NO.: 1190018-012-AC  
PROJECT: Limestone Drying & Processing  
Facility

C.2. Operational Limitations: Baghouse (DC-2) controls emissions from the following emission units as described above:

- A. Screening operations (Emission Unit No. 003).
- B. Optional, the mill & cyclonic air/product separator (Emission Unit No. 004) in part or in total.
- C. Truck loading (Emission Unit No. 006).

[Rule 62-210.200(PTE), F.A.C.]

C.3. Particulate Matter Emission Limitation: Particulate matter emissions from baghouse (DC-2) shall at all times not exceed the following:

- A. 0.022 gr/dscf
- B. 1.9 lbs./hr.
- C. 8.3 tons/yr.
- D. When any of the activities controlled by baghouse DC-2 are operating, even if the Screening, Truck Loading, and Rotary Mill & Cyclonic air/product separator are each operating alone, the emissions from baghouse DC-2 are subject to these emissions limitations.

[40 CFR 60.672(a)(1) and Rule 62-210.200(PTE), F.A.C.]

C.4. Visible Emission Limitation: Visible emissions from baghouse (DC-2) shall at all times not exceed 7% opacity. When any of the activities controlled by baghouse DC-2 are operating, even if the Screening, Truck Loading, and Rotary Mill & Cyclonic air/product separator are each operating alone, the emissions from baghouse DC-2 are subject to this emission limitation. [40 CFR 60.672(a)(2)]

C.5. Recordkeeping Requirements: The permittee shall comply with the following:

- A. Documentation of the hours of operation and processing rate of dried limestone for this emission unit shall be considered the same as the dryer (Emission Unit No. 002). The records required above to document the dryer's (Emission Unit No. 002) hours of operation and process input rate shall be considered the same for this emission unit. Therefore, the dryer's records shall also be used to document the hours of operation and the amount of material (throughput) for this emission unit in the Annual Operating Report required pursuant to Rule 62-210.370, F.A.C.
- B. Daily record the pressure drop across baghouse (DC-2) in inches of water.

[Rule 62-4.070(3), F.A.C.]

PERMITTEE:  
Consolidated Minerals, Inc.

FINAL PERMIT NO.: 1190018-012-AC  
PROJECT: Limestone Drying & Processing  
Facility

C.6. Testing Frequency Requirements: Baghouse (DC-2) emissions shall be initially tested for particulate matter and visible emissions within 60 days after the effective date of this permit and annually thereafter during each federal fiscal year (October 1 – September 30).

[Rule 62-297.310(7), F.A.C.]

C.7. Test Method Requirements: The permittee shall comply with the following test methods:

- A. Method 5 or Method 17 shall be used to determine the particulate matter emissions. The sample volume shall be at least 60 dscf. For Method 5, if the gas stream being sampled is at ambient temperature, the sampling probe and filter may be operated without heaters. If the gas stream is above ambient temperature, the sampling probe and filter may be operated at a temperature high enough, but no higher than 250 °F, to prevent water condensation on the filter.
- B. Method 9 shall be used to determine opacity.
- C. For only the initial test, the visible emission test shall be conducted concurrently with the particulate matter emission testing and be a minimum of at least 3 hours in duration.
- D. After the initial test, the visible emission test shall be conducted concurrently with one of the three particulate matter emission test runs and be at least 30 minutes in duration.

[40 CFR 60.11 and 40 CFR 60.675(b)]

C.8. Operating Requirements During Testing: Testing of baghouse (DC-2) emissions shall be conducted with the following activities occurring simultaneously:

- A. When the wet limestone input rate to the dryer is within 90-100% of the permitted capacity of 35 tons/hr.
- B. When screening operations are occurring.
- C. When the mill's emissions are being totally controlled by baghouse (DC-2).
- D. When the milling operations are occurring.
- E. When trucks are being loaded within 90-100% of the permitted capacity of 108 tons/hr. and when oiling the limestone product from silo SS-1 is not being conducted.

PERMITTEE:  
Consolidated Minerals, Inc.

FINAL PERMIT NO.: 1190018-012-AC  
PROJECT: Limestone Drying & Processing  
Facility

- F. If it is impractical to test within 90-100% of the dryer's and truck loading's permitted capacities, an emission unit may be tested at less than the maximum permitted capacities; in this case, subsequent emissions unit operation is limited to 110% of the tested rate until a new test is conducted. Once the unit is so limited, operation at higher capacities is allowed for no more than 15 consecutive days for the purpose of additional compliance testing to regain the authority to operate up to the maximum permitted capacity.

[Rule 62-297.310(2), F.A.C.]

C.9. Test Report Requirements: Test reports shall be submitted to the Air Compliance Section of this office within 45 days of testing. Be sure to attach to each test report:

- A. A statement of the dryer's actual wet process input rate for the test day in tons/hr.
- B. A copy of the dryer's daily records for the test day.
- C. A copy of the dryer's monthly records for the month the test was conducted.
- D. A copy of the truck loading records that documents the loading rate for each truck loaded during testing.
- E. A copy of the monthly truck loading records for the month the test was conducted.
- F. A copy of the daily pressure drop record for baghouse (DC-2).
- G. A statement that all of the mill's emissions were being controlled by baghouse (DC-2).

[Rules 62-4.070(3) and 62-297.310(8), F.A.C.]

C.10. Test Notifications: The permittee shall comply with the following:

- A. For each initial test: The permittee shall notify the Air Compliance Section of this office at least 30 days prior to the test date on which each formal compliance test is to begin, of the date, time, and place of each such test, and the test contact person who will be responsible for coordinating and having such test conducted for the owner or operator.
- B. For each annual test after the initial test: The permittee shall notify the Air Compliance Section of this office at least 15 days prior to the test date on which each formal compliance test is to begin, of the date, time, and place of each such test, and the test contact person who will be responsible for coordinating and having such test conducted for the owner or operator.

[40 CFR 60.7(a)(6) and Rule 62-297.310(7)(a)9., F.A.C.]



PERMITTEE:  
Consolidated Minerals, Inc.

FINAL PERMIT NO.: 1190018-012-AC  
PROJECT: Limestone Drying & Processing  
Facility

C.11. Circumvention of Air Pollution Control Device : No person shall circumvent any air pollution control device, or allow the emission of air pollutants without the applicable control device operating properly.

{Permitting Note: The requirements of this condition cannot supercede any applicable NSPS requirement.}

[Rule 62-210.650, F.A.C.]

The following conditions apply to Milling (non-NSPS) - Emission Unit No. 004:

D.1. Permitted Capacity: The processing rate of dried limestone for the milling operations shall be considered the same as the dryer's wet limestone process input rate. The wet limestone process input rate to the dryer shall not exceed the following:

- A. 35 tons/hr. based on a daily average.
- B. 306,600 tons per any consecutive 12-month period.

{Permitting Note: The approximate maximum process input rate to the milling activities is 30.8 tons/hr. from the dryer based on a daily average (35 x 0.88).}

[Rule 62-210.200 (PTE), F.A.C.]

D.2. Operational Limitations: Emissions from the rotary mill that are routed to the cyclonic air/product separator are controlled by baghouse (DC-2) and/or baghouse (DC-3).

[Rule 62-210.200(PTE), F.A.C.]

D.3. Particulate matter emissions from the rotary mill when controlled by baghouse (DC-3) either totally or partially shall not exceed the following:

- A. 1.2 lbs./hr.
- B. 5.3 tons/yr.

The maximum allowable particulate emissions from the rotary mill are stricter than Rule 62-296.320(4)(a), F.A.C. – Process Weight Table. Since the nature of this process does not allow the rotary mill to operate below the process input rate of 0.17 tons/hr., which is where the allowable emissions from the process weight table would be more stringent than these emission limitations, Rule 62-296.320(4)(a), F.A.C. is considered not applicable.

[Rule 62-210.200(PTE), F.A.C.; Requested by permittee in application dated August 9, 2005]

D.4. Visible Emissions Limitation: Visible emissions from the rotary mill when controlled by baghouse (DC-3) either partially or totally shall not be equal to or exceed 20% opacity.

[Rule 62-296.320(4)(b), F.A.C.]

PERMITTEE:  
Consolidated Minerals, Inc.

FINAL PERMIT NO.: 1190018-012-AC  
PROJECT: Limestone Drying & Processing  
Facility

D.5. Recordkeeping Requirements: The permittee shall comply with the following:

- A. Documentation of the hours of operation and processing rate of dried limestone for this emission unit shall be considered the same as the dryer (Emission Unit No. 002). The records required above to document the dryer's (Emission Unit No. 002) hours of operation and process input rate shall be considered the same for this emission unit. Therefore, the dryer's records shall also be used to document the hours of operation and the amount of material (throughput) for this emission unit in the Annual Operating Report required pursuant to Rule 62-210.370, F.A.C.
- B. Daily record the pressure drop across baghouse (DC-3) in inches of water.

[Rule 62-4.070(3), F.A.C.]

D.6. Particulate and Visible Emission Test Frequency Requirements: Baghouse (DC-3) emissions shall be tested for particulate matter and visible emissions within 60 days after the effective date of this permit and annually thereafter during each federal fiscal year (October 1 – September 30).

[Rule 62-297.310(7), F.A.C.]

D.7. Test Method Requirements: Testing of emissions from the dryer's baghouse (DC-3) shall be in accordance with the following test methods:

- A. EPA Method Nos. 5 for particulate matter emissions.
- B. EPA Method No. 9 for visible emissions. The observation period shall be at least 30 minutes in duration.

The test methods are contained in 40 CFR 60, Appendix A, which is adopted and incorporated by reference in Rule 62-204.800(8), F.A.C.

[Rules 62-297.310(4) and 62-297.401, F.A.C.; 40 CFR 60, Appendix A]

D.8. Operating Rate During Testing Requirements: Testing of emissions shall be conducted when the wet limestone input rate to the dryer is within 90-100% of the permitted capacity of 35 tons/hr. and when all the emissions from the rotary mill are being controlled by only baghouse (DC-3). If it is impractical to test at the permitted capacity, an emission unit may be tested at less than the maximum permitted capacity; in this case, subsequent emissions unit operation is limited to 110% of the tested input rate until a new test is conducted. Once the unit is so limited, operation at higher capacities is allowed for no more than 15 consecutive days for the purpose of additional compliance testing to regain the authority to operate up to the maximum permitted capacity.

[Rule 62-297.310(2), F.A.C.]

PERMITTEE:  
Consolidated Minerals, Inc.

FINAL PERMIT NO.: 1190018-012-AC  
PROJECT: Limestone Drying & Processing  
Facility

D.9. Test Report Requirements: Test reports shall be submitted to the Air Compliance Section of this office within 45 days of testing. Be sure to attach to each test report:

- A. A statement of the dryer's actual wet process input rate for the test day in tons/hr.
- B. A copy of the dryer's daily records for the test day.
- C. A copy of the dryer's monthly records for the month the test was conducted.
- D. A copy of the daily pressure drop record for baghouse (DC-3).
- E. A statement that all of the rotary mill's emissions were being controlled by baghouse (DC-3)..

[Rules 62-4.070(3) and 62-297.310(8), F.A.C.]

D.10. Test Notifications: The permittee shall notify the Air Compliance Section of this office at least 15 days prior to the test date on which each formal compliance test is to begin, of the date, time, and place of each such test, and the test contact person who will be responsible for coordinating and having such test conducted for the owner or operator.

[Rule 62-297.310(7)(a)9., F.A.C.]

D.11. Circumvention: The permittee shall not circumvent any air pollution control device, or allow the emission of air pollutants without the applicable air pollution control device operating properly.

[Rule 62-210.650, F.A.C.]

The following conditions apply to the Four (4) Storage Silos (NSPS) - Emission Unit No. 005:

E.1. Permitted Capacity: The dried limestone filling rate for the "bank of 4 limestone storage silos" shall be considered the same as the dryer's wet limestone process input rate. The wet limestone process input rate to the dryer shall not exceed the following:

- A. 35 tons/hr. based on a daily average.
- B. 306,600 tons per any consecutive 12-month period.

[Rule 62-210.200(PTE), F.A.C.]

E.2. Operational Limitation: The dried and screened limestone from the cyclonic air/product separate and captured particulate from baghouse DC-3 cannot be loaded into storage silos SS-2 and SS-3 simultaneously.

[Rule 62-210.200(PTE), F.A.C.]

PERMITTEE:  
Consolidated Minerals, Inc.

FINAL PERMIT NO.: 1190018-012-AC  
PROJECT: Limestone Drying & Processing  
Facility

E.3. Particulate Matter Emission Limitation: Particulate matter emissions from baghouse (DC-4) shall at all times not exceed the following:

- A. 0.022 gr/dscf
- B. 0.9 lbs./hr.
- C. 3.9 tons/yr.

[40 CFR 60.672(a)(1), 40 CFR 60.672(g), and Rule 62-210.200(PTE), F.A.C.]

E.4. Visible Emission Limitation: Visible emissions from baghouse (DC-4) shall at all times not exceed 7% opacity.

[40 CFR 60.672(a)(2), 40 CFR 60.672(g), and Rule 62-210.200(PTE), F.A.C.]

E.5. Recordkeeping Requirements: The permittee shall comply with the following:

- A. Documentation of the hours of operation and processing rate of dried limestone for this "group of 4 limestone storage silos" shall be considered the same as the dryer (Emission Unit No. 002). The records required above to document the dryer's (Emission Unit No. 002) hours of operation and process input rate shall be considered the same for this emission unit. Therefore, the dryer's records shall also be used to document the hours of operation and the amount of material (throughput) for this emission unit in the Annual Operating Report required pursuant to Rule 62-210.370, F.A.C.
- B. Daily record the pressure drop across baghouse (DC-4) in inches of water.

[Rule 62-4.070(3), F.A.C.]

E.6. Testing Frequency Requirements: Baghouse (DC-4) emissions shall be initially tested for particulate matter and visible emissions within 60 days after the effective date of this permit and annually thereafter during each federal fiscal year (October 1 – September 30).

[Rule 62-297.310(7), F.A.C.]

PERMITTEE:  
Consolidated Minerals, Inc.

FINAL PERMIT NO.: 1190018-012-AC  
PROJECT: Limestone Drying & Processing  
Facility

E.7. Test Method Requirements: The permittee shall comply with the following test methods:

- A. Method 5 or Method 17 shall be used to determine the particulate matter emissions. The sample volume shall be at least 60 dscf. For Method 5, if the gas stream being sampled is at ambient temperature, the sampling probe and filter may be operated without heaters. If the gas stream is above ambient temperature, the sampling probe and filter may be operated at a temperature high enough, but no higher than 250 °F, to prevent water condensation on the filter.
- B. Method 9 shall be used to determine opacity.
- C. For only the initial test, the visible emission test shall be conducted concurrently with the particulate matter emission testing and be a minimum of at least 3 hours in duration.
- D. After the initial test, the visible emission test shall be conducted concurrently with one of the three particulate matter emission test runs and be at least 30 minutes in duration.

[40 CFR 60.11 and 40 CFR 60.675(b); Rule 62-297.310(4), F.A.C.]

E.8. Operating Requirements During Testing: Testing of baghouse (DC-4) emissions shall be conducted with the following activities occurring simultaneously:

- A. When the wet limestone input rate to the dryer is within 90-100% of the permitted capacity of 35 tons/hr.
- B. When screening operations are occurring.
- D. When the milling operations are occurring.
- E. When trucks are being loaded within 90-100% of the permitted capacity of 108 tons/hr. and when oiling the limestone product from silo SS-1 is not being conducted.
- F. When baghouses DC-1, DC-2, DC-3, and DC-4 are operating.
- G. If it is impractical to test within 90-100% of the dryer's and truck loading's permitted capacities, an emission unit may be tested at less than the maximum permitted capacities; in this case, subsequent emissions unit operation is limited to 110% of the tested rate until a new test is conducted. Once the unit is so limited, operation at higher capacities is allowed for no more than 15 consecutive days for the purpose of additional compliance testing to regain the authority to operate up to the maximum permitted capacity.

[Rule 62-297.310(2), F.A.C.]

PERMITTEE:  
Consolidated Minerals, Inc.

FINAL PERMIT NO.: 1190018-012-AC  
PROJECT: Limestone Drying & Processing  
Facility

E.9. Test Report Requirements: Test reports shall be submitted to the Air Compliance Section of this office within 45 days of testing. Be sure to attach to each test report:

- A. A statement of the dryer's actual wet process input rate for the test day in tons/hr.
- B. A copy of the dryer's daily records for the test day.
- C. A copy of the dryer's monthly records for the month the test was conducted.
- D. A copy of the daily pressure drop record for baghouse (DC-4).
- E. A copy of the truck loading records that documents the loading rate for each truck loaded during testing.
- F. A copy of the monthly truck loading records for the month the test was conducted.
- G. A statement listing all of the processes that were operating and being controlled by baghouse (DC-4) during the test.

[Rules 62-4.070(3) and 62-297.310(8), F.A.C.]

E.10. Test Notifications: The permittee shall comply with the following:

- A. For each initial test: The permittee shall notify the Air Compliance Section of this office at least 30 days prior to the test date on which each formal compliance test is to begin, of the date, time, and place of each such test, and the test contact person who will be responsible for coordinating and having such test conducted for the owner or operator.
- B. For each annual test after the initial test: The permittee shall notify the Air Compliance Section of this office at least 15 days prior to the test date on which each formal compliance test is to begin, of the date, time, and place of each such test, and the test contact person who will be responsible for coordinating and having such test conducted for the owner or operator.

[40 CFR 60.7(a)(6) and Rule 62-297.310(7)(a)9., F.A.C.]

E.11. Circumvention of Air Pollution Control Device : No person shall circumvent any air pollution control device, or allow the emission of air pollutants without the applicable control device operating properly.

{Permitting Note: The requirements of this condition cannot supercede any applicable NSPS requirement.}

[Rule 62-210.650, F.A.C.]

PERMITTEE:  
Consolidated Minerals, Inc.

FINAL PERMIT NO.: 1190018-012-AC  
PROJECT: Limestone Drying & Processing  
Facility

The following conditions apply to Truck Loading Operations (NSPS) - Emission Unit No. 006:

F.1. Permitted Capacity: Trucks are loaded at the maximum loading rate of 108 tons/hr. (based on the actual filling time of the truck divided by the actual loading time of the truck).  
[Rule 62-210.200(PTE), F.A.C.]

F.2. Operational Limitations: Dried Limestone (product) from Storage Silos SS-1, SS-2, SS-3, and SS-4 is transferred to a truck loading station where only 1 truck at any one time may be loaded.  
[Rule 62-210.200(PTE), F.A.C.]

F.3. Operational Limitations: Baghouse (DC-2) controls emissions from the following emission units as described above:

- A. Screening operations (Emission Unit No. 003).
- B. Optional, the mill & cyclonic air/product separator (Emission Unit No. 004) in part or in total.
- C. Truck loading (Emission Unit No. 006).

[Rule 62-210.200(PTE), F.A.C.]

F.4. Particulate Matter Emission Limitation: Particulate matter emissions from baghouse (DC-2) shall at all times not exceed the following:

- A. 0.022 gr/dscf
- B. 1.9 lbs./hr.
- C. 8.3 tons/yr.
- D. When any of the activities controlled by baghouse DC-2 are operating, even if the Screening, Truck Loading, and Rotary Mill & Cyclonic air/product separator are each operating alone, the emissions from baghouse DC-2 are subject to these emissions limitations.

[40 CFR 60.672(a)(1) and Rule 62-210.200(PTE), F.A.C.]

F.5. Visible Emission Limitation: Visible emissions from baghouse (DC-2) shall at all times not exceed 7% opacity. When any of the activities controlled by baghouse DC-2 are operating, even if the Screening, Truck Loading, and Rotary Mill & Cyclonic air/product separator are each operating alone, the emissions from baghouse DC-2 are subject to this emission limitation.

[40 CFR 60.672(a)(2)]

PERMITTEE:  
Consolidated Minerals, Inc.

FINAL PERMIT NO.: 1190018-012-AC  
PROJECT: Limestone Drying & Processing  
Facility

F.6. Recordkeeping Requirements: The permittee shall record the following at a minimum to document the loading rate to each truck:

FOR EACH TRUCK LOADED

- A. The actual amount of product (dried limestone) loaded, in tons.
- B. The actual amount of time to load the truck, in hours.
- C. The actual loading rate of the truck, in tons/hr.

DAILY

- D. The pressure drop across baghouse (DC-2) in inches of water.

MONTHLY

- E. The total amount of product load into trucks, in tons.
- F. The most recent consecutive 12-month period total amount of product loaded into trucks.
- G. The total hours of loading trucks.
- H. The most recent consecutive 12-month period total hours of loading trucks.

[Rule 62-4.070(3), F.A.C.]

F.7. Testing Frequency Requirements: Baghouse (DC-2) emissions shall be initially tested for particulate matter and visible emissions within 60 days after the effective date of this permit and annually thereafter during each federal fiscal year (October 1 – September 30).

[Rule 62-297.310(7), F.A.C.]



PERMITTEE:  
Consolidated Minerals, Inc.

FINAL PERMIT NO.: 1190018-012-AC  
PROJECT: Limestone Drying & Processing  
Facility

F.8. Test Method Requirements: The permittee shall comply with the following test methods:

- A. Method 5 or Method 17 shall be used to determine the particulate matter emissions. The sample volume shall be at least 60 dscf. For Method 5, if the gas stream being sampled is at ambient temperature, the sampling probe and filter may be operated without heaters. If the gas stream is above ambient temperature, the sampling probe and filter may be operated at a temperature high enough, but no higher than 250 °F, to prevent water condensation on the filter.
- B. Method 9 shall be used to determine opacity.
- C. For only the initial test, the visible emission test shall be conducted concurrently with the particulate matter emission testing and be a minimum of at least 3 hours in duration.
- D. After the initial test, the visible emission test shall be conducted concurrently with one of the three particulate matter emission test runs and be at least 30 minutes in duration.

[40 CFR 60.11 and 40 CFR 60.675(b)]

F.9. Operating Requirements During Testing: Testing of baghouse (DC-2) emissions shall be conducted with the following activities occurring simultaneously:

- A. When the wet limestone input rate to the dryer is within 90-100% of the permitted capacity of 35 tons/hr.
- B. When screening operations are occurring.
- C. When the mill's emissions are being totally controlled by baghouse (DC-2).
- D. When the milling operations are occurring.
- E. When trucks are being loaded within 90-100% of the permitted capacity of 108 tons/hr. and when oiling the limestone product from silo SS-1 is not being conducted.
- F. If it is impractical to test within 90-100% of the dryer's and truck loading's permitted capacities, an emission unit may be tested at less than the maximum permitted capacities; in this case, subsequent emissions unit operation is limited to 110% of the tested rate until a new test is conducted. Once the unit is so limited, operation at higher capacities is allowed for no more than 15 consecutive days for the purpose of additional compliance testing to regain the authority to operate up to the maximum permitted capacity.

[Rule 62-297.310(2), F.A..C.]

PERMITTEE:  
Consolidated Minerals, Inc.

FINAL PERMIT NO.: 1190018-012-AC  
PROJECT: Limestone Drying & Processing  
Facility

F.10. Test Report Requirements: Test reports shall be submitted to the Air Compliance Section of this office within 45 days of testing. Be sure to attach to each test report:

- A. A statement of the dryer's actual wet process input rate for the test day in tons/hr.
- B. A copy of the dryer's daily records for the test day.
- C. A copy of the dryer's monthly records for the month the test was conducted.
- D. A copy of the truck loading records that documents the loading rate for each truck loaded during testing.
- E. A copy of the monthly truck loading records for the month the test was conducted.
- F. A copy of the daily pressure drop record for baghouse (DC-2).
- G. A statement that all of the mill's emissions were being controlled by baghouse (DC-2).

[Rules 62-4.070(3) and 62-297.310(8), F.A.C.]

F.11. Test Notifications: The permittee shall comply with the following:

- A. For the initial test: The permittee shall notify the Air Compliance Section of this office at least 30 days prior to the test date on which each formal compliance test is to begin, of the date, time, and place of each such test, and the test contact person who will be responsible for coordinating and having such test conducted for the owner or operator.
- B. For each annual test after the initial test: The permittee shall notify the Air Compliance Section of this office at least 15 days prior to the test date on which each formal compliance test is to begin, of the date, time, and place of each such test, and the test contact person who will be responsible for coordinating and having such test conducted for the owner or operator.

[40 CFR 60.7(a)(6) and Rule 62-297.310(7)(a)9., F.A.C.]

F.12. Circumvention of Air Pollution Control Device : No person shall circumvent any air pollution control device, or allow the emission of air pollutants without the applicable control device operating properly.

{Permitting Note: The requirements of this condition cannot supercede any applicable NSPS requirement.}

[Rule 62-210.650, F.A.C.]

PERMITTEE:  
Consolidated Minerals, Inc.

FINAL PERMIT NO.: 1190018-012-AC  
PROJECT: Limestone Drying & Processing  
Facility

The following conditions apply to Fugitive Emissions from Inside the Enclosed Building (NSPS) - Emission Unit No. 008:

G.1. Permitted Capacity: The processing rate of limestone for the "group of affective fugitive sources of emissions from inside the enclosed building" (Affected fugitive sources ⇒ Crusher (CR-02), Feed Bin (BN-1) to the Feed Table (TF-1), belt conveyor (BC-3), and belt conveyor (BC-4)) shall be considered the same as the dryer's wet limestone process input rate. The wet limestone process input rate to the dryer shall not exceed the following:

- A. 35 tons/hr. based on a daily average.
- B. 306,600 tons per any consecutive 12-month period.

[Rule 62-210.200 (PTE), F.A.C.]

G.2. Visible Emission Limitation: The enclosed building shall have no visible emissions.  
[40 CFR 60.672(e)(1)]

G.3. Recordkeeping Requirements: Documentation of the hours of operation and processing rate material for this "group of fugitive emissions from inside the enclosed building" shall be considered the same as the dryer (Emission Unit No. 002). The records required above to document the dryer's (Emission Unit No. 002) hours of operation and process input rate shall be considered the same for this emission unit. Therefore, the dryer's records shall also be used to document the hours of operation and the amount of material (throughput) for this emission unit in the Annual Operating Report required pursuant to Rule 62-210.370, F.A.C.

[Rule 62-4.070(3), F.A.C.]

G.4. Testing Frequency Requirements: Fugitive emissions from the enclosed building shall be initially tested for visible emissions within 60 days after the effective date of this permit and annually thereafter during each federal fiscal year (October 1 – September 30).

[Rule 62-297.310(7), F.A.C.]

PERMITTEE:  
Consolidated Minerals, Inc.

FINAL PERMIT NO.: 1190018-012-AC  
PROJECT: Limestone Drying & Processing  
Facility

G.5. Test Method Requirements: The permittee shall use EPA Method 22 to determine fugitive visible emissions from the enclosed building. The performance test shall be conducted while all the affected sources inside the building are operating and when the dryer is operating within 90-100% of its permitted capacity. The performance test for the building shall be at least 75 minutes in duration, with each side of the building and the roof being observed for at least 15 minutes.

Emission Point No.	Brief Description	Visible Emission Limit
1	North Side of Building	No visible emissions
2	East Side of Building	No visible emissions
3	South Side of Building	No visible emissions
4	West Side of Building	No visible emissions
5	Roof of Building	No visible emissions

[40 CFR 60.675(d) and Rule 62-297.310(2), F.A.C.]

G.6. Test Report Requirements: Test reports shall be submitted to the Air Compliance Section of this office within 45 days of testing. Be sure to attach to each test report:

- A. A statement of the dryer's actual wet process input rate for the test day in tons/hr.
- B. A copy of the daily records for the test day.
- C. A copy of the monthly records for the month the dryer was tested.
- D. A statement that the affected sources as listed above were operating during the tests.

[Rules 62-4.070(3) and 62-297.310(8), F.A.C.]

G.7. Test Notifications: The permittee shall comply with the following:

- A. For each initial test: The permittee shall notify the Air Compliance Section of this office at least 30 days prior to the test date on which each formal compliance test is to begin, of the date, time, and place of each such test, and the test contact person who will be responsible for coordinating and having such test conducted for the owner or operator.
- B. For each annual test after the initial test: The permittee shall notify the Air Compliance Section of this office at least 15 days prior to the test date on which each formal compliance test is to begin, of the date, time, and place of each such test, and the test contact person who will be responsible for coordinating and having such test conducted for the owner or operator.

[40 CFR 60.7(a)(6) and Rule 62-297.310(7)(a)9., F.A.C.]

PERMITTEE:  
Consolidated Minerals, Inc.

FINAL PERMIT NO.: 1190018-012-AC  
PROJECT: Limestone Drying & Processing  
Facility

**COMMON CONDITIONS FOR EMISSION UNIT  
NOS. 003, 005, 006, 007, and 008**

H.1. NSPS Applicability Requirement: These emission units are subject to the applicable portions of Attachment NSPS - New Source Performance Standards (NSPS) of Title 40 Code of Federal Regulations (CFR) Part 60, Subpart OOO – Standards of Performance for Nonmetallic Mineral Processing Plants, which is adopted and incorporated by reference in Rule 62-204.800(8), F.A.C.

STATE OF FLORIDA DEPARTMENT  
OF ENVIRONMENTAL PROTECTION

*Mara Grace Nasca*  
Mara Grace Nasca  
District Air Program Administrator  
Southwest District

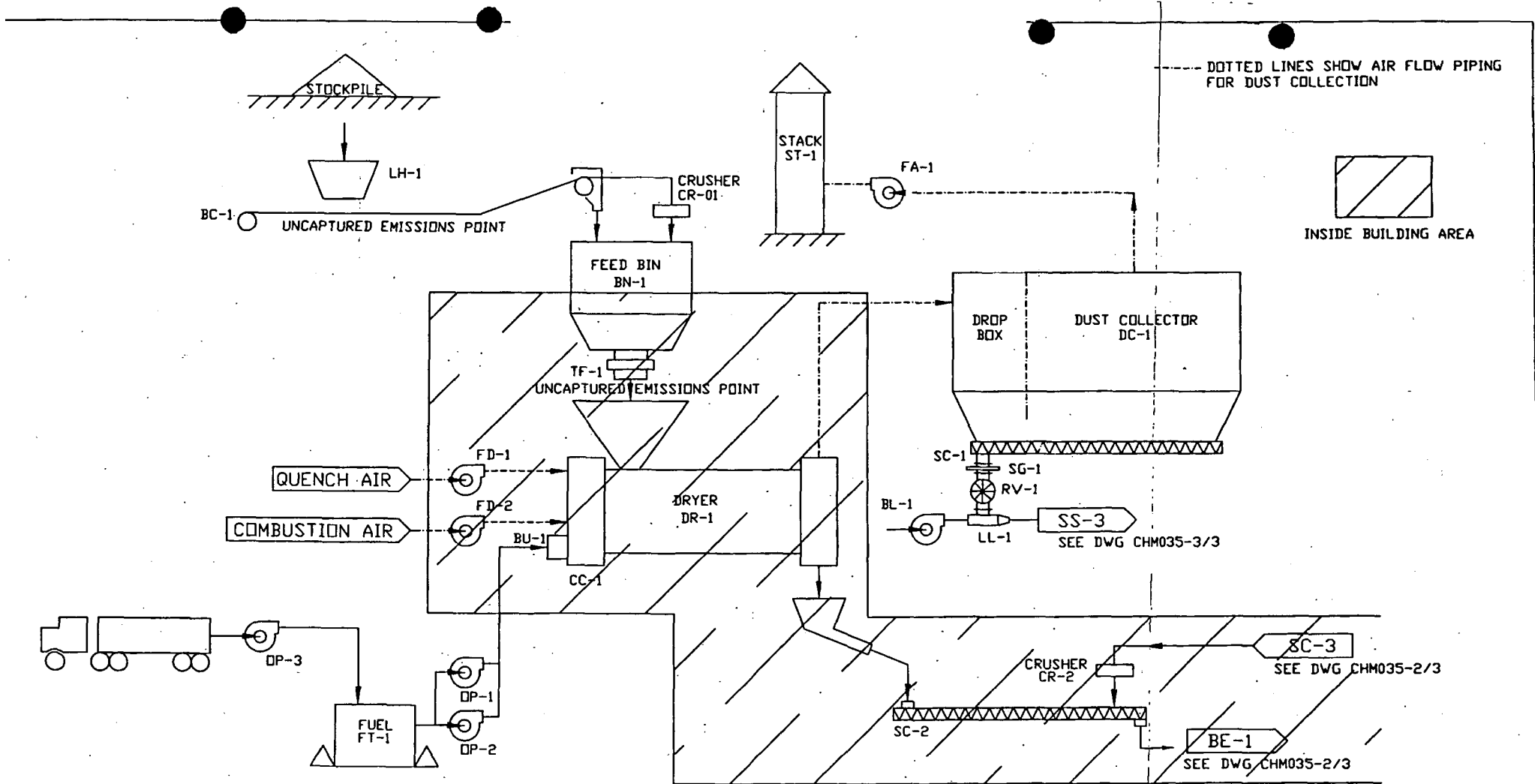

**FLORIDA CRUSHED STONE**  
**LEESBURG** **FLORIDA**

				P	DESIGN PROCESS CHANGE	07/28/03	RS
				O	DESIGN PROCESS CHANGE	06/07/05	RS
				N	DESIGN PROCESS CHANGE	10/22/88	JMC
				M	DESIGN PROCESS CHANGE	10/14/98	JMC
				K	DESIGN PROCESS CHANGE	7/15/98	JMC
				J	DESIGN PROCESS CHANGE	9/3/97	JMC
DESCRIPTION	DRAWING No	DATE	ISSUED TO	NO.	REVISION	DATE	BY
REFERENCE DRAWINGS							

DATE	6/10/96	APPROVED BY	CHECKED BY	DRAWN BY
SCALE	N.T.C.			J.M.C.
PROCESS FLOW DIAGRAM LIMESTONE DRYING & GRINDING				
CENTER HILL FLORIDA	CHANGED NUMBER	CHM035-1/3		



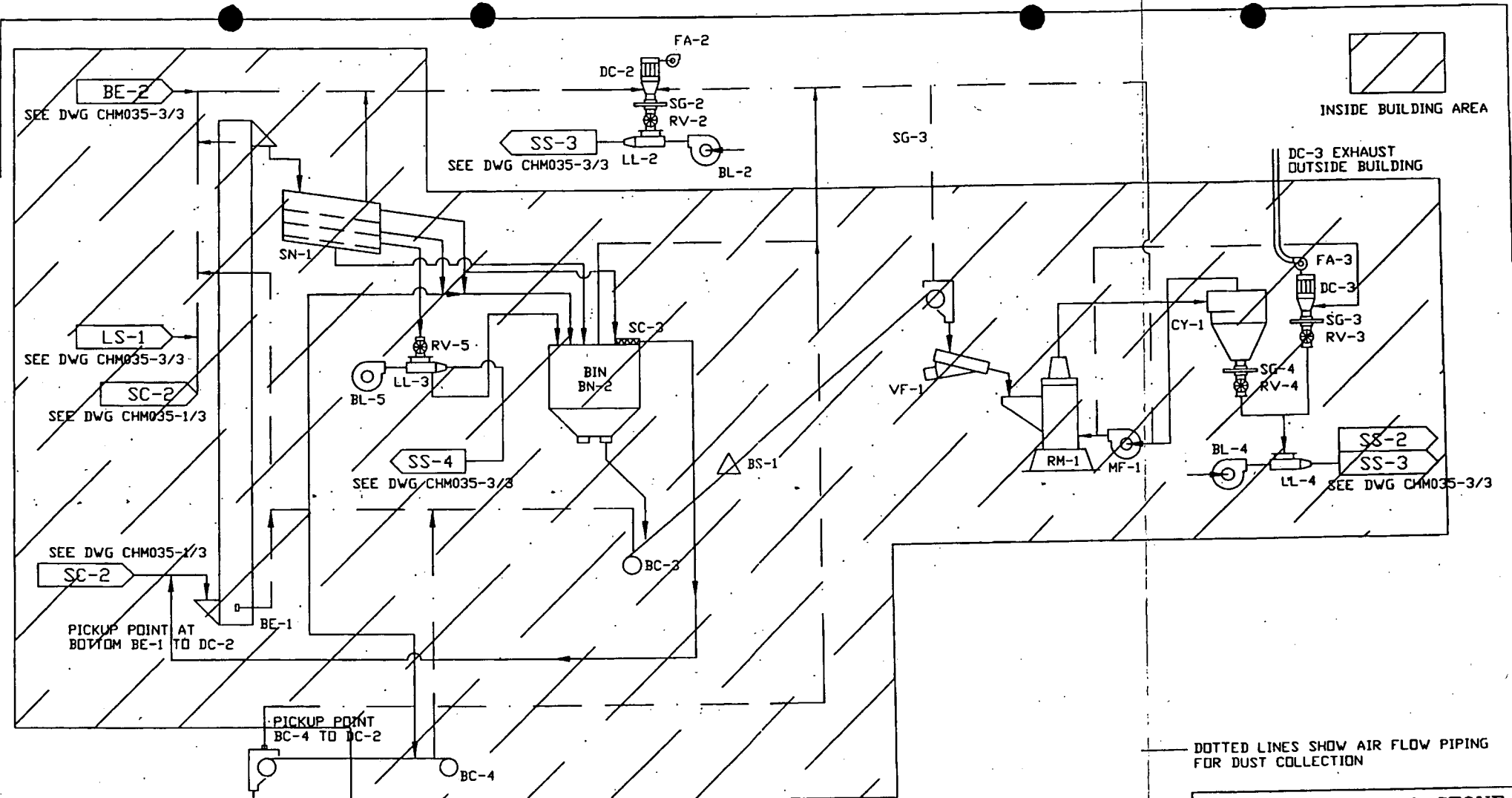

— DOTTED LINES SHOW AIR FLOW PIPING FOR DUST COLLECTION

<b>FLORIDA CRUSHED STONE</b>	
<b>LEESBURG</b>	<b>FLORIDA</b>
DATE 6/10/96	APPROVED BY
SCALE N.T.C.	CHECKED BY
DRAWN BY J.M.C.	
PROCESS FLOW DIAGRAM LIMESTONE DRYING & GRINDING	
CENTER HILL FLORIDA	DRAWING NUMBER CHM035-2/3

Q	DESIGN PROCESS CHANGE	10/06/05	RS				
P	DESIGN PROCESS CHANGE	07/28/05	RS				
O	DESIGN PROCESS CHANGE	06/07/05	RS				
N	DESIGN PROCESS CHANGE	10/22/98	JMC				
M	DESIGN PROCESS CHANGE	10/14/98	JMC				
k	DESIGN PROCESS CHANGE	7/16/98	JMC				
j	DESIGN PROCESS CHANGE	9/3/97	JMC				
DESCRIPTION	DRAWING No	DATE	ISSUED TO	NO.	REVISION	DATE	BY
REFERENCE DRAWINGS							

BE-2  
SEE DWG CHM035-3/3

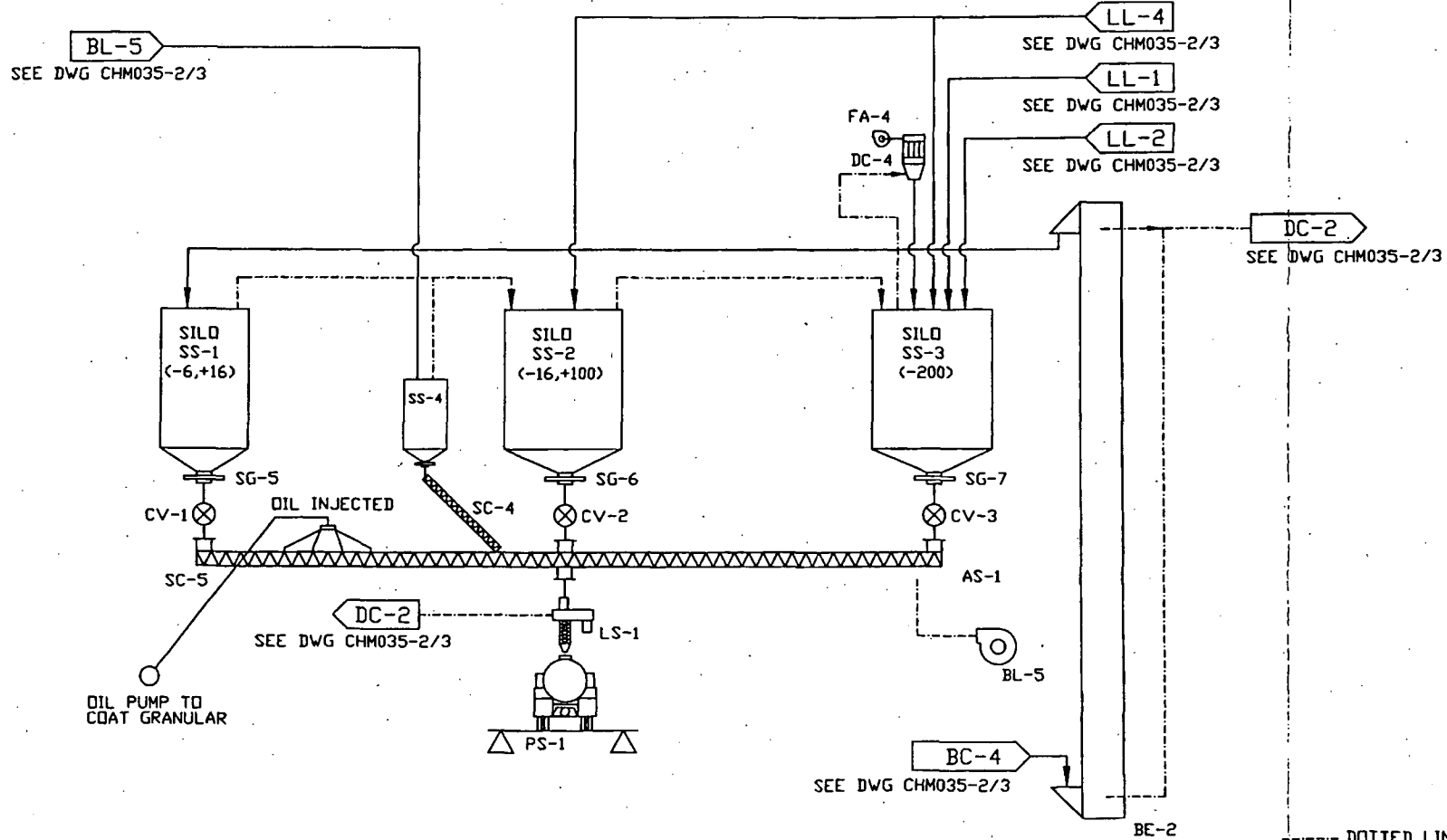

DOTTED LINES SHOW AIR FLOW PIPING FOR AIR SLIDES

**FLORIDA CRUSHED STONE**

**LEESBURG FLORIDA**

DATE 1/13/97 APPROVED BY \_\_\_\_\_ CHECKED BY \_\_\_\_\_ DRAWN BY J.M.C.

SCALE N.T.C.

PROCESS FLOW DIAGRAM  
LIMESTONE DRYING & GRINDING

CENTER HILL FLORIDA DRAWING NUMBER CHM035-3/3

DESCRIPTION	DRAWING No	DATE	ISSUED TO	NO.	REVISION	DATE	BY
					Q DESIGN PROCESS CHANGE	10/07/05	RS
					P DESIGN PROCESS CHANGE	07/28/05	RS
					O DESIGN PROCESS CHANGE	06/07/05	RS
					N DESIGN PROCESS CHANGE	10/22/98	JMC
					M DESIGN PROCESS CHANGE	10/14/98	JMC
					K DESIGN PROCESS CHANGE	7/15/98	JMC
					J DESIGN PROCESS CHANGE	9/3/97	JMC



**GENERAL PROVISIONS**  
**Title 40 Code of Federal Regulations, Subpart A**  
**(For Consolidated Minerals, Inc.'s permit 1190018-012-AC)**

**Updated 7-9-02**

**[Source: Federal Register dated 7/1/98, Federal Register 5/8/98, 2/12/99, 10/17/00, 6/28/02]**

**Subpart A-General Provisions for 40 CFR 60**

**40 CFR 60.1 Applicability.**

(a) Except as provided in 40 CFR 60 subparts B and C, the provisions of this part apply to the owner or operator of any stationary source which contains an affected facility, the construction or modification of which is commenced after the date of publication in this part of any standard (or, if earlier, the date of publication of any proposed standard) applicable to that facility.

(b) Any new or revised standard of performance promulgated pursuant to section 111(b) of the Act shall apply to the owner or operator of any stationary source which contains an affected facility, the construction or modification of which is commenced after the date of publication in this part of such new or revised standard (or, if earlier, the date of publication of any proposed standard) applicable to that facility.

(c) In addition to complying with the provisions of this part, the owner or operator of an affected facility may be required to obtain an operating permit issued to stationary sources by an authorized State air pollution control agency or by the Administrator of the U.S. Environmental Protection Agency (EPA) pursuant to Title V of the Clean Air Act (CAA) as amended November 15, 1990 (42 U.S.C. 7661).

[40 CFR 60.1(a), (b) and (c)]

**40 CFR 60.5 Determination of construction or modification.**

(a) When requested to do so by an owner or operator, the Administrator will make a determination of whether action taken or intended to be taken by such owner or operator constitutes construction (including reconstruction) or modification or the commencement thereof within the meaning of this part.

(b) The Administrator will respond to any request for a determination under paragraph (a) of this section within 30 days of receipt of such request.

**§ 60.6 Review of plans.**

(a) When requested to do so by an owner or operator, the Administrator will review plans for construction or modification for the purpose of providing technical advice to the owner or operator.

(b)(1) A separate request shall be submitted for each construction or modification project.

(2) Each request shall identify the location of such project, and be accompanied by technical information describing the proposed nature, size, design, and method of operation of each affected facility involved in such project, including information on any equipment to be used for measurement or control of emissions.

(c) Neither a request for plans review nor advice furnished by the Administrator in response to such request shall (1) relieve an owner or operator of legal responsibility for compliance with any provision of this part or

of any applicable State or local requirement, or (2) prevent the Administrator from implementing or enforcing any provision of this part or taking any other action authorized by the Act.

#### **40 CFR 60.7 Notification and record keeping.**

(a) Any owner or operator subject to the provisions of this part shall furnish the Administrator written notification or, if acceptable to both the Administrator and the owner or operator of a source, electronic notification, as follows:

1. A notification of the date construction (or reconstruction as defined under § 60.15) of an affected facility is commenced postmarked no later than 30 days after such date. This requirement shall not apply in the case of mass-produced facilities which are purchased in completed form.

2. Reserved.

3. A notification of the actual date of initial startup of an affected facility postmarked within 15 days after such date.

4. A notification of any physical or operational change to an existing facility which may increase the emission rate of any air pollutant to which a standard applies, unless that change is specifically exempted under an applicable subpart or in § 60.14(e). This notice shall be postmarked 60 days or as soon as practicable before the change is commenced and shall include information describing the precise nature of the change, present and proposed emission control systems, productive capacity of the facility before and after the change, and the expected completion date of the change. The Administrator may request additional relevant information subsequent to this notice.

5. A notification of the date upon which demonstration of the continuous monitoring system performance commences in accordance with 40 CFR 60.13(c). Notification shall be postmarked not less than 30 days prior to such date.

6. A notification of the anticipated date for conducting the opacity observations required by 40 CFR 60.11(e)(1) of this part. The notification shall also include, if appropriate, a request for the Administrator to provide a visible emissions reader during a performance test. The notification shall be postmarked not less than 30 days prior to such date.

7. A notification that continuous opacity monitoring system data results will be used to determine compliance with the applicable opacity standard during a performance test required by 40 CFR 60.8 in lieu of Method 9 observation data as allowed by 40 CFR 60.11(e)(5) of 40 CFR 60. This notification shall be postmarked not less than 30 days prior to the date of the performance test.

(b) Any owner or operator subject to the provisions of this part shall maintain records of the occurrence and duration of any startup, shutdown, or malfunction in the operation of an affected facility; any malfunction of the air pollution control equipment; or any periods during which a continuous monitoring system or monitoring device is inoperative.

(c) Each owner or operator required to install a continuous monitoring system (CMS) or monitoring device shall submit an excess emissions and monitoring systems performance report (excess emissions are defined in applicable subparts) and/or a summary report form (see paragraph (d) of this section) to the Administrator semiannually, except when: more frequent reporting is specifically required by an applicable subpart; or the Administrator, on a case-by-case basis, determines that more frequent reporting is necessary to accurately assess the compliance status of the source. All reports shall be postmarked by the 30th day following the end of each six-month period. Written reports of excess emissions shall include the following information:

(1) The magnitude of excess emissions computed in accordance with 40 CFR 60.13(h), any conversion factor(s) used, and the date and time of commencement and completion of each time period of excess emissions. The process operating time during the reporting period.

(2) Specific identification of each period of excess emissions that occurs during startups, shutdowns, and malfunctions of the affected facility. The nature and cause of any malfunction (if known), the corrective action taken or preventative measures adopted.

(3) The date and time identifying each period during which the continuous monitoring system was inoperative except for zero and span checks and the nature of the system repairs or adjustments.

(4) When no excess emissions have occurred or the continuous monitoring system(s) have not been inoperative, repaired, or adjusted, such information shall be stated in the report.

(d) The summary report form shall contain the information and be in the format shown in Figure 1 unless otherwise specified by the Administrator. One summary report form shall be submitted for each pollutant monitored at each affected facility.

(1) If the total duration of excess emissions for the reporting period is less than 1 percent of the total operating time for the reporting period and CMS downtime for the reporting period is less than 5 percent of the total operating time for the reporting period, only the summary report form shall be submitted and the excess emission report described in 40 CFR 60.7(c) need not be submitted unless requested by the Administrator.

(2) If the total duration of excess emissions for the reporting period is 1 percent or greater of the total operating time for the reporting period or the total CMS downtime for the reporting period is 5 percent or greater of the total operating time for the reporting period, the summary report form and the excess emission report described in 40 CFR 60.7(c) shall both be submitted.

*[See Attached Figure 1-Summary Report-Gaseous and Opacity Excess Emission and Monitoring System Performance]*

(e) (1) Notwithstanding the frequency of reporting requirements specified in paragraph (c) of this section, an owner or operator who is required by an applicable subpart to submit excess emissions and monitoring systems performance reports (and summary reports) on a quarterly (or more frequent) basis may reduce the frequency of reporting for that standard to semiannual if the following conditions are met:

(i) For 1 full year (e.g., 4 quarterly or 12 monthly reporting periods) the affected facility's excess emissions and monitoring systems reports submitted to comply with a standard under this part continually demonstrate that the facility is in compliance with the applicable standard;

(ii) The owner or operator continues to comply with all recordkeeping and monitoring requirements specified in this subpart and the applicable standard; and

(iii) The Administrator does not object to a reduced frequency of reporting for the affected facility, as provided in paragraph (e)(2) of this section.

(2) The frequency of reporting of excess emissions and monitoring systems performance (and summary) reports may be reduced only after the owner or operator notifies the Administrator in writing of his or her intention to make such a change and the Administrator does not object to the intended change. In deciding whether to approve a reduced frequency of reporting, the Administrator may review information concerning the source's entire previous performance history during the required recordkeeping period prior to the intended change, including performance test results, monitoring data, and evaluations of an owner or operator's conformance with operation and maintenance requirements. Such information may be used by the Administrator to make a judgment about the source's potential for noncompliance in the future. If the Administrator disapproves the owner or operator's request to reduce the frequency of reporting, the Administrator will notify the owner or operator in writing within 45 days after receiving notice of the owner or operator's intention. The notification from the Administrator to the owner or operator will specify the grounds on which the disapproval is based. In the absence of a notice of disapproval within 45 days, approval is automatically granted.

(3) As soon as monitoring data indicate that the affected facility is not in compliance with any emission limitation or operating parameter specified in the applicable standard, the frequency of reporting shall revert to the frequency specified in the applicable standard, and the owner or operator shall submit an excess emissions and monitoring systems performance re-port (and summary report, if required) at the next appropriate reporting period following the noncomplying event. After demonstrating compliance with the applicable standard for another full year, the owner or operator may again request approval from the Administrator to reduce the frequency of reporting for that standard as provided for in paragraphs (e)(1) and (e)(2) of this section.

(f) Any owner or operator subject to the provisions of this part shall maintain a file of all measurements, including continuous monitoring system, monitoring device, and performance testing measurements; all continuous monitoring system performance evaluations; all continuous monitoring system or monitoring device calibration checks; adjustments and maintenance performed on these systems or devices; and all other information required by this part recorded in a permanent form suitable for inspection. The file shall be retained for at least two years following the date of such measurements, maintenance, reports, and records, except as follows:

(1) This paragraph applies to owners or operators required to install a continuous emissions monitoring system (CEMS) where the CEMS installed is automated, and where the calculated data averages do not exclude periods of CEMS breakdown or malfunction. An automated CEMS records and reduces the measured data to the form of the pollutant emission standard through the use of a computerized data acquisition system. In lieu of maintaining a file of all CEMS subhourly measurements as required under paragraph (f) of this section, the owner or operator shall retain the most recent consecutive three averaging periods of subhourly measurements and a file that contains a hard copy of the data acquisition system algorithm used to reduce the measured data into the reportable form of the standard.

(2) This paragraph applies to owners or operators required to install a CEMS where the measured data is manually reduced to obtain the reportable form of the standard, and where the calculated data averages do not exclude periods of CEMS breakdown or malfunction. In lieu of maintaining a file of all CEMS subhourly measurements as required under paragraph (f) of this section, the owner or operator shall retain all subhourly measurements for the most recent reporting period. The subhourly measurements shall be retained for 120 days from the date of the most recent summary or excess emission report submitted to the Administrator.

(3) The Administrator or delegated authority, upon notification to the source, may require the owner or operator to maintain all measurements as required by paragraph (f) of this section, if the Administrator or the delegated authority determines these records are required to more accurately assess the compliance status of the affected source.

(g) If notification substantially similar to that in 40 CFR 60.7(a) is required by any other State or local agency, sending the Administrator a copy of that notification will satisfy the requirements of 40 CFR 60.7(a).

(h) Individual subparts of this part may include specific provisions which clarify or make inapplicable the provisions set forth in this section.

[40 CFR 60.7(a), (b), (c), (d), (e), (f), (g), (h)]

#### **40 CFR 60.8 Performance tests.**

(a) Within 60 days after achieving the maximum production rate at which the affected facility will be operated, but not later than 180 days after initial startup of such facility and at such other times as may be required by the Administrator under section 114 of the Act, the owner or operator of such facility shall conduct performance test(s) and furnish the Administrator a written report of the results of such performance test(s).

[40 CFR 60.8(a)]

(b) Performance tests shall be conducted and data reduced in accordance with the test methods and procedures contained in each applicable subpart unless the Administrator (1) specifies or approves, in specific cases, the use of a reference method with minor changes in methodology, (2) approves the use of an equivalent method, (3) approves the use of an alternative method the results of which he has determined to be adequate for indicating whether a specific source is in compliance, (4) waives the requirement for performance tests because the owner or operator of a source has demonstrated by other means to the Administrator's satisfaction that the affected facility is in compliance with the standard, or (5) approves shorter sampling times and smaller sample volumes when necessitated by process variables or other factors. Nothing in 40 CFR 60.8 shall be construed to abrogate the Administrator's authority to require testing under section 114 of the Act.

[40 CFR 60.8(b)(1), (2), (3), (4) & (5)]

(c) Performance tests shall be conducted under such conditions as the Administrator shall specify to the plant operator based on representative performance of the affected facility. The owner or operator shall make available to the Administrator such records as may be necessary to determine the conditions of the performance tests. Operations during periods of startup, shutdown, and malfunction shall not constitute representative conditions for the purpose of a performance test nor shall emissions in excess of the level of the applicable emission limit during periods of startup, shutdown, and malfunction be considered a violation of the applicable emission limit unless otherwise specified in the applicable standard.

[40 CFR 60.8(c)].

(d) The owner or operator of an affected facility shall provide the Administrator at least 30 days prior notice of any performance test, except as specified under other subparts, to afford the Administrator the opportunity to have an observer present. If after 30 days notice for an initially scheduled performance test, there is a delay (due to operational problems, etc) in conducting the scheduled performance test, the owner or operator of an affected facility shall notify the administrator (or delegated State or local agency) as soon as possible of any delay in the original test date, either by providing at least 7 days prior notice of the rescheduled date of the performance test, or by arranging a rescheduled date with the Administrator (or delegated State or local agency) by mutual agreement.

(e) The owner or operator of an affected facility shall provide, or cause to be provided, performance testing facilities as follows:

(1) Sampling ports adequate for test methods applicable to such facility. This includes

(i) constructing the air pollution control system such that volumetric flow rates and pollutant emission rates can be accurately determined by applicable test methods and procedures and

(ii) providing a stack or duct free of cyclonic flow during performance tests, as demonstrated by applicable test methods and procedures.

(2) Safe sampling platform(s).

(3) Safe access to sampling platform(s).

(4) Utilities for sampling and testing equipment.

[40 CFR 60.8(e)].

(f) Unless otherwise specified in the applicable subpart, each performance test shall consist of three separate runs using the applicable test method. Each run shall be conducted for the time and under the conditions specified in the applicable standard. For the purpose of determining compliance with an applicable standard, the arithmetic means of results of the three runs shall apply. In the event that a sample is accidentally lost or conditions occur in which one of the three runs must be discontinued because of forced shutdown, failure of an irreplaceable portion of the sample train, extreme meteorological conditions, or other

circumstances, beyond the owner or operator's control, compliance may, upon the Administrator's approval, be determined using the arithmetic mean of the results of the two other runs.  
[40 CFR 60.8(f)].

#### **§ 60.9 Availability of information.**

The availability to the public of information provided to, or otherwise obtained by, the Administrator under this part shall be governed by part 2 of this chapter. (Information submitted voluntarily to the Administrator for the purposes of §§ 60.5 and 60.6 is governed by §§ 2.201 through 2.213 of this chapter and not by § 2.301 of this chapter.)

#### **40 CFR 60.10 State authority.**

The provisions of 40 CFR 60 shall not be construed in any manner to preclude any State or political subdivision thereof from:

(a) Adopting and enforcing any emission standard or limitation applicable to an affected facility, provided that such emission standard or limitation is not less stringent than the standard applicable to such facility.

(b) Requiring the owner or operator of an affected facility to obtain permits, licenses, or approvals prior to initiating construction, modification, or operation of such facility.

[40 CFR 60.10(a) and (b)].

#### **40 CFR 60.11 Compliance with standards and maintenance requirements.**

(a) Compliance with standards in this part, other than opacity standards, shall be determined only by performance tests established by 40 CFR 60.8, unless otherwise specified in the applicable standard.

(b) Compliance with opacity standards in this part shall be determined by conducting observations in accordance with Method 9 in appendix A of this part, any alternative method that is approved by the Administrator, or as provided in 40 CFR 60.11(e)(5). For purposes of determining initial compliance, the minimum total time of observations shall be 3 hours (30 6-minute averages) for the performance test or other set of observations (meaning those fugitive-type emission sources subject only to an opacity standard).

(c) The opacity standards set forth in this part shall apply at all times except during periods of startup, shutdown, malfunction, and as otherwise provided in the applicable standard.

(d) At all times, including periods of startup, shutdown, and malfunction, owners and operators shall, to the extent practicable, maintain and operate any affected facility including associated air pollution control equipment in a manner consistent with good air pollution control practice for minimizing emissions. Determination of whether acceptable operating and maintenance procedures are being used will be based on information available to the Administrator which may include, but is not limited to, monitoring results, opacity observations, review of operating and maintenance procedures, and inspection of the source.

(e) (1) For the purpose of demonstrating initial compliance, opacity observations shall be conducted concurrently with the initial performance test required in 40 CFR 60.8 unless one of the following conditions apply. If no performance test under 40 CFR 60.8 is required, then opacity observations shall be conducted within 60 days after achieving the maximum production rate at which the affected facility will be operated but no later than 180 days after initial startup of the facility. If visibility or other conditions prevent the opacity observations from being conducted concurrently with the initial performance test required under 40 CFR 60.8, the source owner or operator shall reschedule the opacity observations as soon after the initial

performance test as possible, but not later than 30 days thereafter, and shall advise the Administrator of the rescheduled date. In these cases, the 30-day prior notification to the Administrator required in 40 CFR 60.7(a)(6) shall be waived. The rescheduled opacity observations shall be conducted (to the extent possible) under the same operating conditions that existed during the initial performance test conducted under 40 CFR 60.8. The visible emissions observer shall determine whether visibility or other conditions prevent the opacity observations from being made concurrently with the initial performance test in accordance with procedures contained in Method 9 of appendix B of this part. Opacity readings of portions of plumes which contain condensed, uncombined water vapor shall not be used for purposes of determining compliance with opacity standards. The owner or operator of an affected facility shall make available, upon request by the Administrator, such records as may be necessary to determine the conditions under which the visual observations were made and shall provide evidence indicating proof of current visible observer emission certification. Except as provided in 40 CFR 60.11(e)(5), the results of continuous monitoring by transmissometer which indicate that the opacity at the time visual observations were made was not in excess of the standard are probative but not conclusive evidence of the actual opacity of an emission, provided that the source shall meet the burden of proving that the instrument used meets (at the time of the alleged violation) Performance Specification 1 in appendix B of 40 CFR 60, has been properly maintained and (at the time of the alleged violation) that the resulting data have not been altered in any way.

(2) Except as provided in 40 CFR 60.11(e)(3), the owner or operator of an affected facility to which an opacity standard in this part applies shall conduct opacity observations in accordance with 40 CFR 60.11(b), shall record the opacity of emissions, and shall report to the Administrator the opacity results along with the results of the initial performance test required under 40 CFR 60.8. The inability of an owner or operator to secure a visible emissions observer shall not be considered a reason for not conducting the opacity observations concurrent with the initial performance test.

(3) The owner or operator of an affected facility to which an opacity standard in this part applies may request the Administrator to determine and to record the opacity of emissions from the affected facility during the initial performance test and at such times as may be required. The owner or operator of the affected facility shall report the opacity results. Any request to the Administrator to determine and to record the opacity of emissions from an affected facility shall be included in the notification required in 40 CFR 60.7(a)(6). If, for some reason, the Administrator cannot determine and record the opacity of emissions from the affected facility during the performance test, then the provisions of 40 CFR 60.7(e)(1) shall apply.

(4) The owner or operator of an affected facility using a continuous opacity monitor (transmissometer) shall record the monitoring data produced during the initial performance test required by 40 CFR 60.8 and shall furnish the Administrator a written report of the monitoring results along with Method 9 and 40 CFR 60.8 performance test results.

(5) The owner or operator of an affected facility subject to an opacity standard may submit, for compliance purposes, continuous opacity monitoring system (COMS) data results produced during any performance test required under 40 CFR 60.8 in lieu of Method 9 observation data. If an owner or operator elects to submit COMS data for compliance with the opacity standard, he shall notify the Administrator of that decision, in writing, at least 30 days before any performance test required under 40 CFR 60.8 is conducted. Once the owner or operator of an affected facility has notified the Administrator to that effect, the COMS data results will be used to determine opacity compliance during subsequent tests required under 40 CFR 60.8 until the owner or operator notifies the Administrator, in writing, to the contrary. For the purpose of determining compliance with the opacity standard during a performance test required under 40 CFR 60.8 using COMS data, the minimum total time of COMS data collection shall be averages of all 6-minute continuous periods within the duration of the mass emission performance test. Results of the COMS opacity determinations shall be submitted along with the results of the performance test required under 60.8. The owner or operator of an affected facility using a COMS for compliance purposes is responsible for demonstrating that the COMS meets the requirements specified in 40 CFR 60.13(c), that the COMS has been properly maintained and operated, and that the resulting data have not been altered in any way. If COMS data results are submitted for compliance with the opacity standard for a period of time during which Method

9 data indicates noncompliance, the Method 9 data will be used to determine compliance with the opacity standard.

(6) Upon receipt from an owner or operator of the written reports of the results of the performance tests required by 40 CFR 60.8, the opacity observation results and observer certification required by 40 CFR 60.11(e)(1), and the COMS results, if applicable, the Administrator will make a finding concerning compliance with opacity and other applicable standards. If COMS data results are used to comply with an opacity standard, only those results are required to be submitted along with the performance test results required by 40 CFR 60.8. If the Administrator finds that an affected facility is in compliance with all applicable standards for which performance tests are conducted in accordance with 40 CFR 60.8 of this part but during the time such performance tests are being conducted fails to meet any applicable opacity standard, the shall notify the owner or operator and advise him that he may petition the Administrator within 10 days of receipt of notification to make appropriate adjustment to the opacity standard for the affected facility.

(7) The Administrator will grant such a petition upon a demonstration by the owner or operator that the affected facility and associated air pollution control equipment was operated and maintained in a manner to minimize the opacity of emissions during the performance tests; that the performance tests were performed under the conditions established by the Administrator; and that the affected facility and associated air pollution control equipment were incapable of being adjusted or operated to meet the applicable opacity standard.

(8) The Administrator will establish an opacity standard for the affected facility meeting the above requirements at a level at which the source will be able, as indicated by the performance and opacity tests, to meet the opacity standard at all times during which the source is meeting the mass or concentration emission standard. The Administrator will promulgate the new opacity standard in the Federal Register.

(f) Special provisions set forth under an applicable subpart of 40 CFR 60 shall supersede any conflicting provisions of 40 CFR 60.11.

[40 CFR 60.11(a), (b), (c), (d), (e) and (f)]

#### **40 CFR 60.12 Circumvention.**

No owner or operator subject to the provisions of this part shall build, erect, install, or use any article, machine, equipment or process, the use of which conceals an emission which would otherwise constitute a violation of an applicable standard. Such concealment includes, but is not limited to, the use of gaseous diluents to achieve compliance with an opacity standard or with a standard which is based on the concentration of a pollutant in the gases discharged to the atmosphere.

[40 CFR 60.12]

#### **40 CFR 60.13 Monitoring requirements.**

(a) For the purposes of this section, all continuous monitoring systems required under applicable subparts shall be subject to the provisions of this section upon promulgation of performance specifications for continuous monitoring systems under appendix B of 40 CFR 60 and, if the continuous monitoring system is used to demonstrate compliance with emission limits on a continuous basis, appendix F to 40 CFR 60, unless otherwise specified in an applicable subpart or by the Administrator. Appendix F is applicable December 4, 1987.

(b) All continuous monitoring systems and monitoring devices shall be installed and operational prior to conducting performance tests under 40 CFR 60.8. Verification of operational status shall, as a minimum, include completion of the manufacturer's written requirements or recommendations for installation, operation, and calibration of the device.



(c) If the owner or operator of an affected facility elects to submit continuous opacity monitoring system (COMS) data for compliance with the opacity standard as provided under 40 CFR 60.11(e)(5), he/she shall conduct a performance evaluation of the COMS as specified in Performance Specification 1, appendix B, of 40 CFR 60 before the performance test required under 40 CFR 60.8 is conducted. Otherwise, the owner or operator of an affected facility shall conduct a performance evaluation of the COMS or continuous emission monitoring system (CEMS) during any performance test required under 40 CFR 60.8 or within 30 days thereafter in accordance with the applicable performance specification in appendix B of 40 CFR 60. The owner or operator of an affected facility shall conduct COMS or CEMS performance evaluations at such other times as may be required by the Administrator under section 114 of the Act.

(1) The owner or operator of an affected facility using a COMS to determine opacity compliance during any performance test required under 40 CFR 60.8 and as described in 40 CFR 60.11(e)(5), shall furnish the Administrator two or, upon request, more copies of a written report of the results of the COMS performance evaluation described in 40 CFR 60.13(c) at least 10 days before the performance test required under 40 CFR 60.8 is conducted.

(2) Except as provided in 40 CFR 60.13(c)(1), the owner or operator of an affected facility shall furnish the Administrator within 60 days of completion two or, upon request, more copies of a written report of the results of the performance evaluation.

(d) (1) Owners and operators of all continuous emission monitoring systems installed in accordance with the provisions of this part shall check the zero (or low-level value between 0 and 20 percent of span value) and span (50 to 100 percent of span value) calibration drifts at least once daily in accordance with a written procedure. The zero and span shall, as a minimum, be adjusted whenever the 24-hour zero drift or 24-hour span drift exceeds two times the limits of the applicable performance specifications in appendix B. The system must allow the amount of excess zero and span drift measured at the 24-hour interval checks to be recorded and quantified, whenever specified. For a COMS, the optical surfaces, exposed to the effluent gases, must be cleaned before performing the zero and upscale drift adjustments, except for systems using automatic zero adjustments. The optical surfaces must be cleaned when the cumulative automatic zero compensation exceeds 4 percent opacity.

(2) Unless otherwise approved by the Administrator, the following procedures shall be followed for continuous monitoring systems measuring opacity of emissions. Minimum procedures shall include a method for producing a simulated zero opacity condition and an upscale (span) opacity condition using a certified neutral density filter or other related technique to produce a known obscuration of the light beam. Such procedures shall provide a system check of the analyzer internal optical surfaces and all electronic circuitry including the lamp and photo detector assembly.

(e) Except for system breakdowns, repairs, calibration checks, and zero and span adjustments required under 40 CFR 60.13(d), all continuous monitoring systems shall be in continuous operation and shall meet minimum frequency of operation requirements as follows:

(1) All continuous monitoring systems referenced by 40 CFR 60.13(c) for measuring opacity of emissions shall complete a minimum of one cycle of sampling and analyzing for each successive 10-second period and one cycle of data recording for each successive 6-minute period.

(2) All continuous monitoring systems referenced by 40 CFR 60.13(c) for measuring emissions, except opacity, shall complete a minimum of one cycle of operation (sampling, analyzing, and data recording) for each successive 15-minute period.

(f) All continuous monitoring systems or monitoring devices shall be installed such that representative measurements of emissions or process parameters from the affected facility are obtained. Additional procedures for location of continuous monitoring systems contained in the applicable Performance Specifications of appendix B of 40 CFR 60 shall be used.

- (g) (1) When more than one continuous monitoring system is used to measure the emissions from only one affected facility (e.g. multiple breechings, multiple outlets), the owner or operator shall report the results as required from each continuous monitoring system. When the effluent from one affected facility is released to the atmosphere through more than one point, the owner or operator shall install an applicable continuous monitoring system on each separate effluent unless installation of fewer systems is approved by the Administrator.
- (2) When the effluents from two or more affected facilities subject to the same opacity standard are combined before being released to the atmosphere, the owner or operator may either install a continuous opacity monitoring system at a location monitoring the combined effluent or install an opacity combiner system comprised of opacity and flow monitoring systems on each stream, and shall report as per Sec. 60.7(c) on the combined effluent. When the affected facilities are not subject to the same opacity standard applicable, except for documented periods of shutdown of the affected facility, subject to the most stringent opacity standard shall apply
- (3) When the effluents from two or more affected facilities subject to the same emissions standard, other than opacity, are combined before released to the atmosphere, the owner or operator may install applicable continuous monitoring systems on each effluent or on the combined effluent. When the affected facilities are not subject to the continuous monitoring standard, separate continuous monitoring systems shall be installed on each effluent and the owner or operator shall report as required for each affected facility.

(h) Owners or operators of all continuous monitoring systems for measurement of opacity shall reduce all data to 6-minute averages and for continuous monitoring systems other than opacity to 1-hour averages for time periods as defined in 40 CFR 60.2. Six-minute opacity averages shall be calculated from 36 or more data points equally spaced over each 6-minute period. For continuous monitoring systems other than opacity, 1-hour averages shall be computed from four or more data points equally spaced over each 1-hour period. Data recorded during periods of continuous system breakdowns, repairs, calibration checks, and zero and span adjustments shall not be included in the data averages computed under this paragraph. For owners or operators complying with the requirements in Sec. 60.7(f)(1) or (2), data averages must include any data recorded during periods of monitor breakdown or malfunction. An arithmetic or integrated average of all data may be used. The data may be recorded in reduced or non reduced form (e.g., ppm pollutant and percent O<sub>2</sub> or ng or pollutant per J of heat input). All excess emissions shall be converted into units of the standard using the applicable conversion procedures specified in subparts. After conversion into units of the standard, the data may be rounded to the same number of significant digits as used in the applicable subparts to specify the emission limit (e.g., rounded to the nearest 1 percent opacity).  
[Rule 62-296.800, F.A.C.; 40 CFR 60.13(h)].

(i) After receipt and consideration of written application, the Administrator may approve alternatives to any monitoring procedures or requirements of this part including, but not limited to the following:

- (1) Alternative monitoring requirements when installation of a continuous monitoring system or monitoring device specified by this part would not provide accurate measurements due to liquid water or other interferences caused by substances in the effluent gases.
- (2) Alternative monitoring requirements when the affected facility is infrequently operated.
- (3) Alternative monitoring requirements to accommodate continuous monitoring systems that require additional measurements to correct for stack moisture conditions.
- (4) Alternative locations for installing continuous monitoring systems or monitoring devices when the owner or operator can demonstrate that installation at alternate locations will enable accurate and representative measurements.
- (5) Alternative methods of converting pollutant concentration measurements to units of the standards.

(6) Alternative procedures for performing daily checks of zero and span drift that do not involve use of span gases or test cells.

(7) Alternatives to the A.S.T.M. test methods or sampling procedures specified by any subpart.

(8) Alternative continuous monitoring systems that do not meet the design or performance requirements in Performance Specification 1, appendix B, but adequately demonstrate a definite and consistent relationship between its measurements and the measurements of opacity by a system complying with the requirements in Performance Specification 1. The Administrator may require that such demonstration be performed for each affected facility.

(9) Alternative monitoring requirements when the effluent from a single affected facility or the combined effluent from two or more affected facilities is released to the atmosphere through more than one point.

[Rule 62-296.800, F.A.C.; 40 CFR 60.13(i)].

(j) An alternative to the relative accuracy (RA) test specified in Performance Specification 2 of appendix B may be requested as follows:

(1) An alternative to the reference method tests for determining RA is available for sources with emission rates demonstrated to be less than 50 percent of the applicable standard. A source owner or operator may petition the Administrator to waive the RA test in section 8.4 of Performance Specification 2 and substitute the procedures in section 16.0 if the results of a performance test conducted according to the requirements in 40 CFR 60.8 of this subpart or other tests performed following the criteria in 40 CFR 60.8 demonstrate that the emission rate of the pollutant of interest in the units of the applicable standard is less than 50 percent of the applicable standard. For sources subject to standards expressed as control efficiency levels, a source owner or operator may petition the Administrator to waive the RA test and substitute the procedures in section 16.0 of Performance Specification 2 if the control device exhaust emission rate is less than 50 percent of the level needed to meet the control efficiency requirement. The alternative procedures do not apply if the continuous emission monitoring system is used to determine compliance continuously with the applicable standard. The petition to waive the RA test shall include a detailed description of the procedures to be applied. Included shall be location and procedure for conducting the alternative, the concentration or response levels of the alternative RA materials, and the other equipment checks included in the alternative procedure. The Administrator will review the petition for completeness and applicability. The determination to grant a waiver will depend on the intended use of the CEMS data (e.g., data collection purposes other than NSPS) and may require specifications more stringent than in Performance Specification 2 (e.g., the applicable emission limit is more stringent than NSPS).

(2) The waiver of a CEMS RA test will be reviewed and may be rescinded at such time, following successful completion of the alternative RA procedure that the CEMS data indicate the source emissions approaching the level. The criterion for reviewing the waiver is the collection of CEMS data showing that emissions have exceeded 70 percent of the applicable standard for seven, consecutive, averaging periods as specified by the applicable regulation(s). For sources subject to standards expressed as control efficiency levels, the criterion for reviewing the waiver is the collection of CEMS data showing that exhaust emissions have exceeded 70 percent of the level needed to meet the control efficiency requirement for seven, consecutive, averaging periods as specified by the applicable regulation(s) [e.g., 40 CFR 60.45(g)(2) and 40 CFR 60.45(g)(3), 40 CFR 60.73(e), and 40 CFR 60.84(e)]. It is the responsibility of the source operator to maintain records and determine the level of emissions relative to the criterion on the waiver of RA testing. If this criterion is exceeded, the owner or operator must notify the Administrator within 10 days of such occurrence and include a description of the nature and cause of the increasing emissions. The Administrator will review the notification and may rescind the waiver and require the owner or operator to conduct a RA test of the CEMS as specified in section 8.4 of Performance Specification 2.

[Rule 62-296.800, F.A.C.; 40 CFR 60.13(j)].

#### **40 CFR 60.14 Modification.**

(a) Except as provided under 40 CFR 60.14(e) and 40 CFR 60.14(f), any physical or operational change to an existing facility which results in an increase in the emission rate to the atmosphere of any pollutant to which a standard applies shall be considered a modification within the meaning of section 111 of the Act. Upon modification, an existing facility shall become an affected facility for each pollutant to which a standard applies and for which there is an increase in the emission rate to the atmosphere.

[Rule 62-296.800, F.A.C.; 40 CFR 60.14(a)].

(b) Emission rate shall be expressed as kg/hr (lbs./hour) of any pollutant discharged into the atmosphere for which a standard is applicable. The Administrator shall use the following to determine emission rate:

(1) Emission factors as specified in the latest issue of "Compilation of Air Pollutant Emission Factors", EPA Publication No. AP-42, or other emission factors determined by the Administrator to be superior to AP-42 emission factors, in cases where utilization of emission factors demonstrates that the emission level resulting from the physical or operational change will either clearly increase or clearly not increase.

(2) Material balances, continuous monitor data, or manual emission tests in cases where utilization of emission factors as referenced in 40 CFR 60.14(b)(1) does not demonstrate to the Administrator's satisfaction whether the emission level resulting from the physical or operational change will either clearly increase or clearly not increase, or where an owner or operator demonstrates to the Administrator's satisfaction that there are reasonable grounds to dispute the result obtained by the Administrator utilizing emission factors as referenced in 40 CFR 60.14(b)(1). When the emission rate is based on results from manual emission tests or continuous monitoring systems, the procedures specified in 40 CFR 60 appendix C of 40 CFR 60 shall be used to determine whether an increase in emission rate has occurred. Tests shall be conducted under such conditions as the Administrator shall specify to the owner or operator based on representative performance of the facility. At least three valid test runs must be conducted before and at least three after the physical or operational change. All operating parameters which may affect emissions must be held constant to the maximum feasible degree for all test runs.

[Rule 62-296.800, F.A.C.; 40 CFR 60.14(b)].

(c) The addition of an affected facility to a stationary source as an expansion to that source or as a replacement for an existing facility shall not by itself bring within the applicability of this part any other facility within that source.

[Rule 62-296.800, F.A.C.; 40 CFR 60.14(c)].

(d) [Reserved]

(e) The following shall not, by themselves, be considered modifications under this part:

(1) Maintenance, repair, and replacement which the Administrator determines to be routine for a source category, subject to the provisions of 40 CFR 60.14(c) and 40 CFR 60.15.

(2) An increase in production rate of an existing facility, if that increase can be accomplished without a capital expenditure on that facility.

(3) An increase in the hours of operation.

(4) Use of an alternative fuel or raw material if, prior to the date any standard under this part becomes applicable to that source type, as provided by 40 CFR 60.1, the existing facility was designed to accommodate that alternative use. A facility shall be considered to be designed to accommodate an alternative fuel or raw material if that use could be accomplished under the facility's construction specifications as amended prior to the change. Conversion to coal required for energy considerations, as specified in section 111(a)(8) of the Act, shall not be considered a modification.

(5) The addition or use of any system or device whose primary function is the reduction of air pollutants, except when an emission control system is removed or is replaced by a system which the Administrator determines to be less environmentally beneficial.

(6) The relocation or change in ownership of an existing facility.  
[Rule 62-296.800, F.A.C.; 40 CFR 60.14(e)].

(f) Special provisions set forth under an applicable subpart of this part shall supersede any conflicting provisions of this section.  
[Rule 62-296.800, F.A.C.; 40 CFR 60.14(f)].

(g) Within 180 days of the completion of any physical or operational change subject to the control measures specified in 40 CFR 60.14(a), compliance with all applicable standards must be achieved.  
[Rule 62-296.800, F.A.C.; 40 CFR 60.14(g)].

(h) No physical change, or change in the method of operation, at an existing electric utility steam generating unit shall be treated as a modification for the purposes of this section provided that such change does not increase the maximum hourly emissions of any pollutant regulated under this section above the maximum hourly emissions achievable at that unit during the 5 years prior to the change.

(i) Repowering projects that are awarded funding from the Department of Energy as permanent clean coal technology demonstration projects (or similar projects funded by EPA) are exempt from the requirements of this section provided that such change does not increase the maximum hourly emissions of any pollutant regulated under this section above the maximum hourly emissions achievable at that unit during the five years prior to the change.

(j) (1) Repowering projects that qualify for an extension under section 409(b) of the Clean Air Act are exempt from the requirements of this section, provided that such change does not increase the actual hourly emissions of any pollutant regulated under this section above the actual hourly emissions achievable at that unit during the 5 years prior to the change.

(2) This exemption shall not apply to any new unit that:

(i) Is designated as a replacement for an existing unit;

(ii) Qualifies under section 409(b) of the Clean Air Act for an extension of an emission limitation compliance date under section 405 of the Clean Air Act; and

(iii) Is located at a different site than the existing unit.

(k) The installation, operation, cessation, or removal of a temporary clean coal technology demonstration project is exempt from the requirements of this section. A *temporary clean coal control technology demonstration project*, for the purposes of this section is a clean coal technology demonstration project that is operated for a period of 5 years or less, and which complies with the State implementation plan for the State in which the project is located and other requirements necessary to attain and maintain the national ambient air quality standards during the project and after it is terminated.

(l) The reactivation of a very clean coal-fired electric utility steam generating unit is exempt from the requirements of this section.

#### **40 CFR 60.15 Reconstruction.**

(a) An existing facility, upon reconstruction, becomes an affected facility, irrespective of any change in emission rate.

[Rule 62-296.800, F.A.C.; 40 CFR 60.15(a)].

(b) "Reconstruction" means the replacement of components of an existing facility to such an extent that:

(1) The fixed capital cost of the new components exceeds 50 percent of the fixed capital cost that would be required to construct a comparable entirely new facility, and

(2) It is technologically and economically feasible to meet the applicable standards set forth in this part.

[Rule 62-296.800, F.A.C.; 40 CFR 60.15(b)].

(c) "Fixed capital cost" means the capital needed to provide all the depreciable components.

[Rule 62-296.800, F.A.C.; 40 CFR 60.15(c)].

(d) If an owner or operator of an existing facility proposes to replace components, and the fixed capital cost of the new components exceeds 50 percent of the fixed capital cost that would be required to construct a comparable entirely new facility, he shall notify the Administrator of the proposed replacements. The notice must be postmarked 60 days (or as soon as practicable) before construction of the replacements is commenced and must include the following information:

(1) Name and address of the owner or operator.

(2) The location of the existing facility.

(3) A brief description of the existing facility and the components which are to be replaced.

(4) A description of the existing air pollution control equipment and the proposed air pollution control equipment.

(5) An estimate of the fixed capital cost of the replacements and of constructing a comparable entirely new facility.

(6) The estimated life of the existing facility after the replacements.

(7) A discussion of any economic or technical limitations the facility may have in complying with the applicable standards of performance after the proposed replacements.

[Rule 62-296.800, F.A.C.; 40 CFR 60.15(d)].

(e) The Administrator will determine, within 30 days of the receipt of the notice required by 40 CFR 60.15(d) and any additional information he may reasonably require, whether the proposed replacement constitutes reconstruction.

[Rule 62-296.800, F.A.C.; 40 CFR 60.15(e)].

(f) The Administrator's determination under 40 CFR 60.15(e) shall be based on:

(1) The fixed capital cost of the replacements in comparison to the fixed capital cost that would be required to construct a comparable entirely new facility;

(2) The estimated life of the facility after the replacements compared to the life of a comparable entirely new facility;

(3) The extent to which the components being replaced cause or contribute to the emissions from the facility; and

(4) Any economic or technical limitations on compliance with applicable standards of performance which are inherent in the proposed replacements.

[Rule 62-296.800, F.A.C.; 40 CFR 60.15(f)].

(g) Individual subparts of this part may include specific provisions which refine and delimit the concept of reconstruction set forth in this section.

[Rule 62-296.800, F.A.C.; 40 CFR 60.15(g)].

**§ 60.18 General control device requirements.**

(a) *Introduction.* This section contains requirements for control devices used to comply with applicable subparts of parts 60 and 61. The requirements are placed here for administrative convenience and only apply to facilities covered by subparts referring to this section.

(b) *Flares.* Paragraphs (c) through (f) apply to flares.

(c) (1) Flares shall be designed for and operated with no visible emissions as determined by the methods specified in paragraph (f), except for periods not to exceed a total of 5 minutes during any 2 consecutive hours.

(2) Flares shall be operated with a flame present at all times, as determined by the methods specified in paragraph (f).

(3) An owner/operator has the choice of adhering to either the heat content specifications in paragraph (c)(3)(ii) of this section and the maximum tip velocity specifications in paragraph (c)(4) of this section, or adhering to the requirements in paragraph (c)(3)(i) of this section.

(i) (A) Flares shall be used that have a diameter of 3 inches or greater, are nonassisted, have a hydrogen content of 8.0 percent (by volume), or greater, and are designed for and operated with an exit velocity less than 37.2 m/sec (122 ft/sec) and less than the velocity,  $V_{max}$ , as determined by the following equation:

$$V_{max} = (XH_2 - K_1) * K_2$$

Where:

$V_{max}$  = Maximum permitted velocity, m/sec.

$K_1$  = Constant, 6.0 volume-percent hydrogen.

$K_2$  = Constant, 3.9(m/sec)/volume-percent hydrogen.

$XH_2$  = The volume-percent of hydrogen, on a wet basis, as calculated by using the American Society for Testing and Materials (ASTM) Method D1946-77. (Incorporated by reference as specified in § 60.17).

(B) The actual exit velocity of a flare shall be determined by the method specified in paragraph (f)(4) of this section.

(ii) Flares shall be used only with the net heating value of the gas being combusted being 11.2 MJ/scm (300 Btu/scf) or greater if the flare is steam-assisted or air-assisted; or with the net heating value of the gas being combusted being 7.45 MJ/scm (200 Btu/scf) or greater if the flare is nonassisted. The net heating value of the gas being combusted shall be determined by the methods specified in paragraph (f)(3) of this section.

(4) (i) Steam-assisted and nonassisted flares shall be designed for and operated with an exit velocity, as determined by the methods specified in paragraph (f)(4) of this section, less than 18.3 m/sec (60 ft/sec), except as provided in paragraphs (c)(4) (ii) and (iii) of this section.

(ii) Steam-assisted and nonassisted flares designed for and operated with an exit velocity, as determined by the methods specified in paragraph (f)(4), equal to or greater than 18.3 m/sec (60 ft/sec) but less than 122 m/sec (400 ft/sec) are allowed if the net heating value of the gas being combusted is greater than 37.3 MJ/scm (1,000 Btu/scf).

(iii) Steam-assisted and nonassisted flares designed for and operated with an exit velocity, as determined by the methods specified in paragraph (f)(4), less than the velocity,  $V_{max}$ , as determined by the method specified in paragraph (f)(5), and less than 122 m/sec (400 ft/sec) are allowed.

(5) Air-assisted flares shall be designed and operated with an exit velocity less than the velocity,  $V_{max}$ , as determined by the method specified in paragraph (f)(6).

(6) Flares used to comply with this section shall be steam-assisted, air-assisted, or nonassisted.

(d) Owners or operators of flares used to comply with the provisions of this subpart shall monitor these control devices to ensure that they are operated and maintained in conformance with their designs.

Applicable subparts will provide provisions stating how owners or operators of flares shall monitor these control devices.

(e) Flares used to comply with provisions of this subpart shall be operated at all times when emissions may be vented to them.

(f) (1) Method 22 of appendix A to this part shall be used to determine the compliance of flares with the visible emission provisions of this subpart. The observation period is 2 hours and shall be used according to Method 22.

(2) The presence of a flare pilot flame shall be monitored using a thermocouple or any other equivalent device to detect the presence of a flame.

(3) The net heating value of the gas being combusted in a flare shall be calculated using the following equation:

$$H_T = K \sum_{i=1}^n C_i H_i$$

Eq. 1

where:

HT=Net heating value of the sample, MJ/scm; where the net enthalpy per mole of offgas is based on combustion at 25 °C and 760 mm Hg, but the standard temperature for determining the volume corresponding to one mole is 20 °C;

$$K = \frac{\text{Constant}}{1.740 \times 10^{-7}} \left( \frac{1}{\text{ppm}} \right) \left( \frac{\text{g mole}}{\text{scm}} \right) \left( \frac{\text{MJ}}{\text{kcal}} \right)$$

where the standard temperature for  $\left( \frac{\text{g mole}}{\text{scm}} \right)$  is 20°C;

Eq. 2

C<sub>i</sub>=Concentration of sample component i in ppm on a wet basis, as measured for organics by Reference Method 18 and measured for hydrogen and carbon monoxide by ASTM D1946-77 or 90 (Reapproved 1994) (Incorporated by reference as specified in § 60.17); and

H<sub>i</sub>=Net heat of combustion of sample component i, kcal/g mole at 25 °C and 760 mm Hg. The heats of combustion may be determined using ASTM D2382-76 or 88 or D4809-95 (incorporated by reference as specified in § 60.17) if published values are not available or cannot be calculated.

(4) The actual exit velocity of a flare shall be determined by dividing the volumetric flowrate (in units of standard temperature and pressure), as determined by Reference Methods 2, 2A, 2C, or 2D as appropriate; by the unobstructed (free) cross sectional area of the flare tip.

(5) The maximum permitted velocity, V<sub>max</sub>, for flares complying with paragraph (c)(4)(iii) shall be determined by the following equation. Log<sub>10</sub> (V<sub>max</sub>)=(HT+28.8)/31.7

V<sub>max</sub>=Maximum permitted velocity, M/sec

28.8=Constant

31.7=Constant

HT=The net heating value as determined in paragraph (f)(3).

(6) The maximum permitted velocity, V<sub>max</sub>, for air-assisted flares shall be determined by the following equation. V<sub>max</sub>=8.706+0.7084 (HT)

V<sub>max</sub>=Maximum permitted velocity, m/sec

8.706=Constant

0.7084=Constant

HT=The net heating value as determined in paragraph (f)(3).



**§ 60.19 General notification and reporting requirements.**

(a) For the purposes of this part, time periods specified in days shall be measured in calendar days, even if the word “calendar” is absent, unless otherwise specified in an applicable requirement.

(b) For the purposes of this part, if an explicit postmark deadline is not specified in an applicable requirement for the submittal of a notification, application, report, or other written communication to the Administrator, the owner or operator shall postmark the submittal on or before the number of days specified in the applicable requirement. For example, if a notification must be submitted 15 days before a particular event is scheduled to take place, the notification shall be post-marked on or before 15 days preceding the event; likewise, if a notification must be submitted 15 days after a particular event takes place, the notification shall be delivered or postmarked on or before 15 days following the end of the event. The use of reliable non-Government mail carriers that provide indications of verifiable delivery of information required to be submitted to the Administrator, similar to the post-mark provided by the U.S. Postal Service, or alternative means of delivery, including the use of electronic media, agreed to by the permitting authority, is acceptable.

(c) Notwithstanding time periods or postmark deadlines specified in this part for the submittal of information to the Administrator by an owner or operator, or the review of such information by the Administrator, such time periods or deadlines may be changed by mutual agreement between the owner or operator and the Administrator. Procedures governing the implementation of this provision are specified in paragraph (f) of this section.

(d) If an owner or operator of an affected facility in a State with delegated authority is required to submit periodic reports under this part to the State, and if the State has an established timeline for the submission of periodic reports that is consistent with the reporting frequency(ies) specified for such facility under this part, the owner or operator may change the dates by which periodic reports under this part shall be submitted (without changing the frequency of reporting) to be consistent with the State’s schedule by mutual agreement between the owner or operator and the State. The allowance in the previous sentence applies in each State beginning 1 year after the affected facility is required to be in compliance with the applicable subpart in this part. Procedures governing the implementation of this provision are specified in paragraph (f) of this section.

(e) If an owner or operator supervises one or more stationary sources affected by standards set under this part and standards set under part 61, part 63, or both such parts of this chapter, he/she may arrange by mutual agreement between the owner or operator and the Administrator (or the State with an approved permit program) a common schedule on which periodic reports required by each applicable standard shall be submitted throughout the year. The allowance in the previous sentence applies in each State beginning 1 year after the stationary source is required to be in compliance with the applicable subpart in this part, or 1 year after the stationary source is required to be in compliance with the applicable 40 CFR part 61 or part 63 of this chapter standard, whichever is latest. Procedures governing the implementation of this provision are specified in paragraph (f) of this section.

(f) (1) (i) Until an adjustment of a time period or postmark deadline has been approved by the Administrator under paragraphs (f)(2) and (f)(3) of this section, the owner or operator of an affected facility remains strictly subject to the requirements of this part.

(ii) An owner or operator shall request the adjustment provided for in paragraphs (f)(2) and (f)(3) of this section each time he or she wishes to change an applicable time period or postmark deadline specified in this part.

(2) Notwithstanding time periods or postmark deadlines specified in this part for the submittal of information to the Administrator by an owner or operator, or the review of such information by the Administrator, such time periods or deadlines may be changed by mutual agreement between the owner or operator and the Administrator. An owner or operator who wishes to request a change in a time period or postmark deadline for a particular requirement shall request the adjustment in writing as soon as practicable before the subject activity is required to take place. The owner or operator shall include in the request whatever information he or she considers useful to convince the Administrator that an adjustment is warranted.

(3) If, in the Administrator's judgment, an owner or operator's request for an adjustment to a particular time period or postmark deadline is warranted, the Administrator will approve the adjustment. The Administrator will notify the owner or operator in writing of approval or disapproval of the request for an adjustment within 15 calendar days of receiving sufficient information to evaluate the request.

(4) If the Administrator is unable to meet a specified deadline, he or she will notify the owner or operator of any significant delay and inform the owner or operator of the amended schedule.

a.con  
/raw  
02/14/00

**ATTACHMENT NSPS**  
**New Source Performance Standards (NSPS) of Title 40**  
**Code of Federal Regulations**  
**(For Consolidated Minerals, Inc.'s permit 1190018-012-AC)**

**Updated 2/13/02**

**Subpart OOO-Standards of Performance for Nonmetallic Mineral Processing Plants**

**§ 60.670 Applicability and designation of affected facility.**

(a) (1) Except as provided in paragraphs (a)(2), (b), (c), and (d) of this section, the provisions of this subpart are applicable to the following affected facilities in fixed or portable nonmetallic mineral processing plants: each crusher, grinding mill, screening operation, bucket elevator, belt conveyor, bagging operation, storage bin, enclosed truck or railcar loading station. Also, crushers and grinding mills at hot mix asphalt facilities that reduce the size of nonmetallic minerals embedded in recycled asphalt pavement and subsequent affected facilities up to, but not including, the first storage silo or bin are subject to the provisions of this subpart.

(2) The provisions of this subpart do not apply to the following operations: All facilities located in underground mines; and stand-alone screening operations at plants without crushers or grinding mills.

(b) An affected facility that is subject to the provisions of subpart F or I or that follows in the plant process any facility subject to the provisions of subparts F or I of this part is not subject to the provisions of this subpart.

(c) Facilities at the following plants are not subject to the provisions of this subpart:

(1) Fixed sand and gravel plants and crushed stone plants with capacities, as defined in § 60.671, of 23 megagrams per hour (25 tons per hour) or less;

(2) Portable sand and gravel plants and crushed stone plants with capacities, as defined in § 60.671, of 136 megagrams per hour (150 tons per hour) or less; and

(3) Common clay plants and pumice plants with capacities, as defined in § 60.671, of 9 megagrams per hour (10 tons per hour) or less.

(d) (1) When an existing facility is replaced by a piece of equipment of equal or smaller size, as defined in § 60.671, having the same function as the existing facility, the new facility is exempt from the provisions of §§ 60.672, 60.674, and 60.675 except as provided for in paragraph (d)(3) of this section.

(2) An owner or operator complying with paragraph (d)(1) of this section shall submit the information required in § 60.676(a).

(3) An owner or operator replacing all existing facilities in a production line with new facilities does not qualify for the exemption described in paragraph (d)(1) of this section and must comply with the provisions of §§ 60.672, 60.674 and 60.675.

(e) An affected facility under paragraph (a) of this section that commences construction, reconstruction, or modification after August 31, 1983 is subject to the requirements of this part.

(f) Table 1 of this subpart specifies the provisions of subpart A of this part 60 that apply and those that do not apply to owners and operators of affected facilities subject to this subpart.

**TABLE 1 – APPLICABILITY OF SUBPART A  
TO SUBPART 000**

Subpart A reference	Applies to Subpart 000	Comment
60.1, Applicability .....	Yes	
60.2, Definitions .....	Yes	
60.3, Units and abbreviations .....	Yes	
60.4, Address		
(a) .....	Yes	
(b) .....	Yes	
60.5, Determination of construction .. or modification.	Yes	
60.6, Review of plans .....	Yes	
60.7, Notification and recordkeeping	Yes	Except in (a)(2) report of anticipated date of initial startup is not required (60.676(h)).
60.8, Performance tests .....	Yes	Except in (d), after 30 days notice for an initially scheduled performance test, any rescheduled performance test requires 7 days notice, not 30 days (60.675(g)).
60.9, Availability of information .....	Yes	
60.10, State Authority .....	Yes	
60.11, Compliance with standards and maintenance requirements .....	Yes	Except in (b) under certain conditions (60.675(c)(3) and (c)(4)), Method 9 observation may be reduced from 3 hours to 1 hour. Some affected facilities exempted fro Method 9 tests (60.675(h)).
60.12, Circumvention .....	Yes	
60.13, Monitoring requirements .....	Yes	
60.14, Modification .....	Yes	
60.15, Reconstruction .....	Yes	
60.16, Priority List .....	Yes	
60.17, Incorporated by reference .....	Yes	
60.18, General control device .....	No	Flares will not be used to comply with the emission limits.
60.19, General notification and reporting requirements .....	Yes	

[51 FR 31337, August.1, 1985, as amended at 62 FR 31359, June 9, 1997

## § 60.671 Definitions.

All terms used in this subpart, but not specifically defined in this section, shall have the meaning given them in the Act and in subpart A of this part.

*Bagging operation* means the mechanical process by which bags are filled with nonmetallic minerals.

*Belt conveyor* means a conveying device that transports material from one location to another by means of an endless belt that is carried on a series of idlers and routed around a pulley at each end.

*Bucket elevator* means a conveying device of nonmetallic minerals consisting of a head and foot assembly which supports and drives an endless single or double strand chain or belt to which buckets are attached.

*Building* means any frame structure with a roof.

*Capacity* means the cumulative rated capacity of all initial crushers that are part of the plant.

*Capture system* means the equipment (including enclosures, hoods, ducts, fans, dampers, etc.) used to capture and transport particulate matter generated by one or more process operations to a control device.

*Control device* means the air pollution control equipment used to reduce particulate matter emissions released to the atmosphere from one or more process operations at a nonmetallic mineral processing plant.

*Conveying system* means a device for transporting materials from one piece of equipment or location to another location within a plant. Conveying systems include but are not limited to the following: Feeders, belt conveyors, bucket elevators and pneumatic systems.

*Crusher* means a machine used to crush any nonmetallic minerals, and includes, but is not limited to, the following types: jaw, gyratory, cone, roll, rod mill, hammermill, and impactor.

*Enclosed truck or railcar loading station* means that portion of a nonmetallic mineral processing plant where nonmetallic minerals are loaded by an enclosed conveying system into enclosed trucks or railcars.

*Fixed plant* means any nonmetallic mineral processing plant at which the processing equipment specified in § 60.670(a) is attached by a cable, chain, turnbuckle, bolt or other means (except electrical connections) to any anchor, slab, or structure including bedrock.

*Fugitive emission* means particulate matter that is not collected by a capture system and is released to the atmosphere at the point of generation.

*Grinding mill* means a machine used for the wet or dry fine crushing of any nonmetallic mineral. Grinding mills include, but are not limited to, the following types: hammer, roller, rod, pebble and ball, and fluid energy. The grinding mill includes the air conveying system, air separator, or air classifier, where such systems are used.

*Initial crusher* means any crusher into which nonmetallic minerals can be fed without prior crushing in the plant.

*Nonmetallic mineral* means any of the following minerals or any mixture of which the majority is any of the following minerals:

- (a) Crushed and Broken Stone, including Limestone, Dolomite, Granite, Traprock, Sandstone, Quartz, Quartzite, Marl, Marble, Slate, Shale, Oil Shale, and Shell.
- (b) Sand and Gravel.
- (c) Clay including Kaolin, Fireclay, Bentonite, Fuller's Earth, Ball Clay, and Common Clay.
- (d) Rock Salt.
- (e) Gypsum.
- (f) Sodium Compounds, including Sodium Carbonate, Sodium Chloride, and Sodium Sulfate.

- (g) Pumice.
- (h) Gilsonite.
- (i) Talc and Pyrophyllite.
- (j) Boron, including Borax, Kernite, and Colemanite.
- (k) Barite.
- (l) Fluorospar.
- (m) Feldspar.
- (n) Diatomite.
- (o) Perlite.
- (p) Vermiculite.
- (q) Mica.
- (r) Kyanite, including Andalusite, Sillimanite, Topaz, and Dumortierite.

*Nonmetallic mineral processing plant* means any combination of equipment that is used to crush or grind any nonmetallic mineral wherever located, including lime plants, power plants, steel mills, asphalt concrete plants, portland cement plants, or any other facility processing nonmetallic minerals except as provided in § 60.670 (b) and (c).

*Portable plant* means any nonmetallic mineral processing plant that is mounted on any chassis or skids and may be moved by the application of a lifting or pulling force. In addition, there shall be no cable, chain, turnbuckle, bolt or other means (except electrical connections) by which any piece of equipment is attached or clamped to any anchor, slab, or structure, including bedrock that must be removed prior to the application of a lifting or pulling force for the purpose of transporting the unit.

*Production line* means all affected facilities (crushers, grinding mills, screening operations, bucket elevators, belt conveyors, bagging operations, storage bins, and enclosed truck and railcar loading stations) which are directly connected or are connected together by a conveying system.

*Screening operation* means a device for separating material according to size by passing undersize material through one or more mesh surfaces (screens) in series, and retaining oversize material on the mesh surfaces (screens).

*Size* means the rated capacity in tons per hour of a crusher, grinding mill, bucket elevator, bagging operation, or enclosed truck or railcar loading station; the total surface area of the top screen of a screening operation; the width of a conveyor belt; and the rated capacity in tons of a storage bin.

*Stack emission* means the particulate matter that is released to the atmosphere from a capture system.

*Storage bin* means a facility for storage (including surge bins) or nonmetallic minerals prior to further processing or loading.

*Transfer point* means a point in a conveying operation where the nonmetallic mineral is transferred to or from a belt conveyor except where the nonmetallic mineral is being transferred to a stockpile.

*Truck dumping* means the unloading of nonmetallic minerals from movable vehicles designed to transport nonmetallic minerals from one location to another. Movable vehicles include but are not limited to: trucks, front end loaders, skip hoists, and railcars.

*Vent* means an opening through which there is mechanically induced air flow for the purpose of exhausting from a building air carrying particulate matter emissions from one or more affected facilities.

*Wet mining operation* means a mining or dredging operation designed and operated to extract any nonmetallic mineral regulated under this subpart from deposits existing at or below the water table, where the nonmetallic mineral is saturated with water.

*Wet screening operation* means a screening operation at a nonmetallic mineral processing plant which removes unwanted material or which separates marketable fines from the product by

a washing process which is designed and operated at all times such that the product is saturated with water.

**§ 60.672 Standard for particulate matter.**

(a) On and after the date on which the performance test required to be conducted by § 60.8 is completed, no owner or operator subject to the provisions of this subpart shall cause to be discharged into the atmosphere from any transfer point on belt conveyors or from any other affected facility any stack emissions which:

- (1) Contain particulate matter in excess of 0.05 g/dscm (0.022 gr/dscf); and
- (2) Exhibit greater than 7 percent opacity, unless the stack emissions are discharged from an affected facility using a wet scrubbing control device. Facilities using a wet scrubber must comply with the reporting provisions of § 60.676 (c), (d), and (e).

(b) On and after the sixtieth day after achieving the maximum production rate at which the affected facility will be operated, but not later than 180 days after initial startup as required under § 60.11 of this part, no owner or operator subject to the provisions of this subpart shall cause to be discharged into the atmosphere from any transfer point on belt conveyors or from any other affected facility any fugitive emissions which exhibit greater than 10 percent opacity, except as provided in paragraphs (c), (d), and (e) of this section.

(c) On and after the sixtieth day after achieving the maximum production rate at which the affected facility will be operated, but not later than 180 days after initial startup as required under § 60.11 of this part, no owner or operator shall cause to be discharged into the atmosphere from any crusher, at which a capture system is not used, fugitive emissions which exhibit greater than 15 percent opacity.

(d) Truck dumping of nonmetallic minerals into any screening operation, feed hopper, or crusher is exempt from the requirements of this section.

(e) If any transfer point on a conveyor belt or any other affected facility is enclosed in a building, then each enclosed affected facility must comply with the emission limits in paragraphs (a), (b) and (c) of this section, or the building enclosing the affected facility or facilities must comply with the following emission limits:

(1) No owner or operator shall cause to be discharged into the atmosphere from any building enclosing any transfer point on a conveyor belt or any other affected facility any visible fugitive emissions except emissions from a vent as defined in § 60.671.

(2) No owner or operator shall cause to be discharged into the atmosphere from any vent of any building enclosing any transfer point on a conveyor belt or any other affected facility emissions which exceed the stack emissions limits in paragraph (a) of this section.

(f) On and after the sixtieth day after achieving the maximum production rate at which the affected facility will be operated, but not later than 180 days after initial startup as required under § 60.11 of this part, no owner or operator shall cause to be discharged into the atmosphere from any baghouse that controls emissions from only an individual, enclosed storage bin, stack emissions which exhibit greater than 7 percent opacity.

(g) Owners or operators of multiple storage bins with combined stack emissions shall comply with the emission limits in paragraph (a)(1) and (a)(2) of this section.

(h) On and after the sixtieth day after achieving the maximum production rate at which the affected facility will be operated, but not later than 180 days after initial startup, no owner or operator shall cause to be discharged into the atmosphere any visible emissions from:

(1) Wet screening operations and subsequent screening operations, bucket elevators, and belt conveyors that process saturated material in the production line up to the next crusher, grinding mill or storage bin.

(2) Screening operations, bucket elevators, and belt conveyors in the production line downstream of wet mining operations, where such screening operations, bucket elevators, and belt conveyors process saturated materials up to the first crusher, grinding mill, or storage bin in the production line.

#### **§ 60.673 Reconstruction.**

(a) The cost of replacement of ore-contact surfaces on processing equipment shall not be considered in calculating either the "fixed capital cost of the new components" or the "fixed capital cost that would be required to construct a comparable new facility" under § 60.15. Ore-contact surfaces are crushing surfaces; screen meshes, bars, and plates; conveyor belts; and elevator buckets.

(b) Under § 60.15, the "fixed capital cost of the new components" includes the fixed capital cost of all depreciable components (except components specified in paragraph (a) of this section) which are or will be replaced pursuant to all continuous programs of component replacement commenced within any 2-year period following August 31, 1983.

#### **§ 60.674 Monitoring of operations.**

The owner or operator of any affected facility subject to the provisions of this subpart which uses a wet scrubber to control emissions shall install, calibrate, maintain and operate the following monitoring devices:

(a) A device for the continuous measurement of the pressure loss of the gas stream through the scrubber. The monitoring device must be certified by the manufacturer to be accurate within  $\pm 250$  pascals  $\pm 1$  inch water gauge pressure and must be calibrated on an annual basis in accordance with manufacturer's instructions.

(b) A device for the continuous measurement of the scrubbing liquid flow rate to the wet scrubber. The monitoring device must be certified by the manufacturer to be accurate within  $\pm 5$  percent of design scrubbing liquid flow rate and must be calibrated on an annual basis in accordance with manufacturer's instructions.

#### **§ 60.675 Test methods and procedures.**

(a) In conducting the performance tests required in § 60.8, the owner or operator shall use as reference methods and procedures the test methods in appendix A of this part or other methods and procedures as specified in this section, except as provided in § 60.8(b). Acceptable alternative methods and procedures are given in paragraph (e) of this section.

(b) The owner or operator shall determine compliance with the particulate matter standards in § 60.672(a) as follows:

(1) Method 5 or Method 17 shall be used to determine the particulate matter concentration. The sample volume shall be at least 1.70 dscm (60 dscf). For Method 5, if the gas



stream being sampled is at ambient temperature, the sampling probe and filter may be operated without heaters. If the gas stream is above ambient temperature, the sampling probe and filter may be operated at a temperature high enough, but no higher than 121 °C (250 °F), to prevent water condensation on the filter.

(2) Method 9 and the procedures in § 60.11 shall be used to determine opacity.

(c) (1) In determining compliance with the particulate matter standards in § 60.672 (b) and (c), the owner or operator shall use Method 9 and the procedures in § 60.11, with the following additions:

(i) The minimum distance between the observer and the emission source shall be 4.57 meters (15 feet).

(ii) The observer shall, when possible, select a position that minimizes interference from other fugitive emission sources (e.g., road dust). The required observer position relative to the sun (Method 9, Section 2.1) must be followed.

(iii) For affected facilities using wet dust suppression for particulate matter control, a visible mist is sometimes generated by the spray. The water mist must not be confused with particulate matter emissions and is not to be considered a visible emission. When a water mist of this nature is present, the observation of emissions is to be made at a point in the plume where the mist is no longer visible.

(2) In determining compliance with the opacity of stack emissions from any baghouse that controls emissions only from an individual enclosed storage bin under § 60.672(f) of this subpart, using Method 9, the duration of the Method 9 observations shall be 1 hour (ten 6-minute averages).

(3) When determining compliance with the fugitive emissions standard for any affected facility described under § 60.672(b) of this subpart, the duration of the Method 9 observations may be reduced from 3 hours (thirty 6-minute averages) to 1 hour (ten 6-minute averages) only if the following conditions apply:

(i) There are no individual readings greater than 10 percent opacity; and

(ii) There are no more than 3 readings of 10 percent for the 1-hour period.

(4) When determining compliance with the fugitive emissions standard for any crusher at which a capture system is not used as described under § 60.672(c) of this subpart, the duration of the Method 9 observations may be reduced from 3 hours (thirty 6-minute averages) to 1 hour (ten 6-minute averages) only if the following conditions apply:

(i) There are no individual readings greater than 15 percent opacity; and

(ii) There are no more than 3 readings of 15 percent for the 1-hour period.

(d) In determining compliance with § 60.672(e), the owner or operator shall use Method 22 to determine fugitive emissions. The performance test shall be conducted while all affected facilities inside the building are operating. The performance test for each building shall be at least 75 minutes in duration, with each side of the building and the roof being observed for at least 15 minutes.

(e) The owner or operator may use the following as alternatives to the reference methods and procedures specified in this section:

(1) For the method and procedure of paragraph (c) of this section, if emissions from two or more facilities continuously interfere so that the opacity of fugitive emissions from an individual affected facility cannot be read, either of the following procedures may be used:

(i) Use for the combined emission stream the highest fugitive opacity standard applicable to any of the individual affected facilities contributing to the emissions stream.

(ii) Separate the emissions so that the opacity of emissions from each affected facility can be read.

(f) To comply with § 60.676(d), the owner or operator shall record the measurements as required in § 60.676(c) using the monitoring devices in § 60.674 (a) and (b) during each particulate matter run and shall determine the averages.

(g) If, after 30 days notice for an initially scheduled performance test, there is a delay (due to operational problems, etc.) in conducting any rescheduled performance test required in this section, the owner or operator of an affected facility shall submit a notice to the Administrator at least 7 days prior to any rescheduled performance test.

(h) Initial Method 9 performance tests under § 60.11 of this part and § 60.675 of this subpart are not required for:

(1) Wet screening operations and subsequent screening operations, bucket elevators, and belt conveyors that process saturated material in the production line up to, but not including the next crusher, grinding mill or storage bin.

(2) Screening operations, bucket elevators, and belt conveyors in the production line downstream of wet mining operations, that process saturated materials up to the first crusher, grinding mill, or storage bin in the production line.

### **§ 60.676 Reporting and recordkeeping.**

(a) Each owner or operator seeking to comply with § 60.670(d) shall submit to the Administrator the following information about the existing facility being replaced and the replacement piece of equipment.

(1) For a crusher, grinding mill, bucket elevator, bagging operation, or enclosed truck or railcar loading station:

(i) The rated capacity in megagrams or tons per hour of the existing facility being replaced and

(ii) The rated capacity in tons per hour of the replacement equipment.

(2) For a screening operation:

(i) The total surface area of the top screen of the existing screening operation being replaced and

(ii) The total surface area of the top screen of the replacement screening operation.

(3) For a conveyor belt:

(i) The width of the existing belt being replaced and

(ii) The width of the replacement conveyor belt.

(4) For a storage bin:

(i) The rated capacity in megagrams or tons of the existing storage bin being replaced and

(ii) The rated capacity in megagrams or tons of replacement storage bins.

(b) [Reserved]

(c) During the initial performance test of a wet scrubber, and daily thereafter, the owner or operator shall record the measurements of both the change in pressure of the gas stream across the scrubber and the scrubbing liquid flow rate.

(d) After the initial performance test of a wet scrubber, the owner or operator shall submit semiannual reports to the Administrator of occurrences when the measurements of the scrubber pressure loss (or gain) and liquid flow rate differ by more than  $\pm 30$  percent from the averaged determined during the most recent performance test.

(e) The reports required under paragraph (d) shall be postmarked within 30 days following end of the second and fourth calendar quarters.

(f) The owner or operator of any affected facility shall submit written reports of the results of all performance tests conducted to demonstrate compliance with the standards set forth in § 60.672 of this subpart, including reports of opacity observations made using Method 9 to demonstrate compliance with § 60.672(b), (c), and (f), and reports of observations using Method 22 to demonstrate compliance with § 60.672(e).

(g) The owner or operator of any screening operation, bucket elevator, or belt conveyor that processes saturated material and is subject to § 60.672(h) and subsequently processes unsaturated materials, shall submit a report of this change within 30 days following such change. This screening operation, bucket elevator, or belt conveyor is then subject to the 10 percent opacity limit in § 60.672(b) and the emission test requirements of § 60.11 and this subpart. Likewise a screening operation, bucket elevator, or belt conveyor that processes unsaturated material but subsequently processes saturated material shall submit a report of this change within 30 days following such change. This screening operation, bucket elevator, or belt conveyor is then subject to the no visible emission limit in § 60.672(h).

(h) The subpart A requirement under § 60.7(a)(2) for notification of the anticipated date of initial startup of an affected facility shall be waived for owners or operators of affected facilities regulated under this subpart.

(i) A notification of the actual date of initial startup of each affected facility shall be submitted to the Administrator.

(1) For a combination of affected facilities in a production line that begin actual initial startup on the same day, a single notification of startup may be submitted by the owner or operator to the Administrator. The notification shall be postmarked within 15 days after such date and shall include a description of each affected facility, equipment manufacturer, and serial number of the equipment, if available.

(2) For portable aggregate processing plants, the notification of the actual date of initial startup shall include both the home office and the current address or location of the portable plant.

(j) The requirements of this section remain in force until and unless the Agency, in delegating enforcement authority to a State under section 111(c) of the Act, approves reporting requirements or an alternative means of compliance surveillance adopted by such States. In that event, affected facilities within the State will be relieved of the obligation to comply with the reporting requirements of this section, provided that they comply with requirements established by the State.

## ATTACHMENT - GENERAL CONDITIONS

1. The terms, conditions, requirements, limitations and restrictions set forth in this permit, are "Permit Conditions" and are binding and enforceable pursuant to Sections 403.141, 403.727, or 403.859 through 403.861, Florida Statutes (F.S.). The permittee is placed on notice that the Department will review this permit periodically and may initiate enforcement action for any violation of these conditions.
2. This permit is valid only for the specific processes and operations applied for and indicated in the approved drawings or exhibits. Any unauthorized deviation from the approved drawings, exhibits, specifications, or conditions of this permit may constitute grounds for revocation and enforcement action by the Department.
3. As provided in subsections 403.087(6) and 403.722(5), F.S., the issuance of this permit does not convey any vested rights or any exclusive privileges. Neither does it authorize any injury to public or private property or any invasion of personal rights, nor any infringement of federal, state, or local laws or regulations. This permit is not a waiver of or approval of any other Department permit that may be required for other aspects of the total project which are not addressed in this permit.
4. Not applicable to Air Permits.
5. This permit does not relieve the permittee from liability for harm or injury to human health or welfare, animal, or plant life, or property caused by the construction or operation of this permitted source, or from penalties therefore; nor does it allow the permittee to cause pollution in contravention of Florida Statutes and Department rules, unless specifically authorized by an order from the Department.
6. The permittee shall properly operate and maintain the facility and systems of treatment and control (and related appurtenances) that are installed and used by the permittee to achieve compliance with the conditions of this permit, are required by Department rules. This provision includes the operation of backup or auxiliary facilities or similar systems when necessary to achieve compliance with the conditions of the permit and when required by Department rules.
7. The permittee, by accepting this permit, specifically agrees to allow authorized Department personnel, upon presentation of credentials or other documents as may be required by law and at reasonable times, access to the premises where the permitted activity is located or conducted to:
  - a. Have access to and copy any records that must be kept under conditions of the permit;
  - b. Inspect the facility, equipment, practices, or operations regulated or required under this permit; and
  - c. Sample or monitor any substances or parameters at any location reasonable necessary to assure compliance with this permit or Department rules.

Reasonable time may depend on the nature of the concern being investigated.

8. If, for any reason, the permittee does not comply with or will be unable to comply with any condition or limitation specified in this permit, the permittee shall immediately provide the Department with the following information:
  - a. A description of and cause of noncompliance; and
  - b. The period of noncompliance, including dates and times; or, if not corrected, the anticipated time the noncompliance is expected to continue, and steps being taken to reduce, eliminate, and prevent recurrence of the noncompliance. The permittee shall be responsible for any and all damages which may result and may be subject to enforcement action by the Department for penalties or for revocation of this permit.

## ATTACHMENT - GENERAL CONDITIONS

9. In accepting this permit, the permittee understands and agrees that all records, notes, monitoring data and other information relating to the construction or operation of this permitted source which are submitted to the Department may be used by the Department as evidence in any enforcement case involving the permitted source arising under the Florida Statutes or Department rules, except where such use is prescribed by Section 403.111 and 403.73, F.S. Such evidence shall only be used to the extent it is consistent with the Florida Rules of Civil Procedure and appropriate evidentiary rules.

10. The permittee agrees to comply with changes in Department rules and Florida Statutes after a reasonable time for compliance; provided, however, the permittee does not waive any other rights granted by Florida Statutes or Department rules.

11. This permit is transferable only upon Department approval in accordance with Rule 62-4.120 and 62-730.300 F.A.C., as applicable. The permittee shall be liable for any non-compliance of the permitted activity until the transfer is approved by the Department.

12. This permit or a copy thereof shall be kept at the work site of the permitted activity.

13. This permit also constitutes:

- Determination of Best Available Control Technology (BACT)
- Determination of Prevention of Significant Deterioration (PSD)
- Compliance with New Source Performance Standards (NSPS)

14. The permittee shall comply with the following:

- a. Upon request, the permittee shall furnish all records and plans required under Department rules. During enforcement actions, the retention period for all records will be extended automatically unless otherwise stipulated by the Department.
- b. The permittee shall hold at the facility or other location designated by this permit records of all monitoring information (including all calibration and maintenance records and all original strip chart recordings for continuous monitoring instrumentation) required by the permit, copies of all reports required by this permit, and records of all data used to complete the application for this permit. These materials shall be retained at least three years from the date of the sample, measurement, report, or application unless otherwise specified by Department rule.
- c. Records of monitoring information shall include:
  - 1. the date, exact place, and time of sampling or measurements;
  - 2. the person responsible for performing the sampling or measurements;
  - 3. the dates analyses were performed;
  - 4. the person responsible for performing the analyses;
  - 5. the analytical techniques or methods used;
  - 6. the results of such analyses.

15. When requested by the Department, the permittee shall within a reasonable time furnish any information required by law which is needed to determine compliance with the permit. If the permittee becomes aware the relevant facts were not submitted or were incorrect in the permit application or in any report to the Department, such facts or information shall be corrected promptly.

16. Not applicable to Air Permits.

17. Not applicable to Air Permits.