



*Rec'd  
2/18/04*

**TITLE V OPERATION PERMIT RENEWAL  
APPLICATION FOR  
RIDGE GENERATING STATION**

*(+ AC Modification)*

*1050216-007-AC*

*1050216-008-AV*

*Issued by D. Zell*

*4/22/05*

*3/15/06*

**Prepared for:**

**Wheelabrator Ridge Energy Inc.  
3131 K-ville Avenue  
Auburndale, FL 33823**

**Prepared by:**

**Golder Associates Inc.  
6241 NW 23rd Street, Suite 500  
Gainesville, Florida 32653-1500**

**February 2004  
0337622**

**DISTRIBUTION:**

**4 Copies – FDEP**

**2 Copies – Wheelabrator Ridge Energy Inc.**

**1 Copy – Golder Associates Inc.**

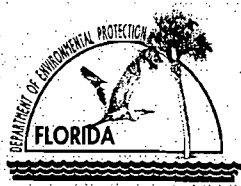

# Department of Environmental Protection

## Division of Air Resource Management APPLICATION FOR AIR PERMIT - LONG FORM

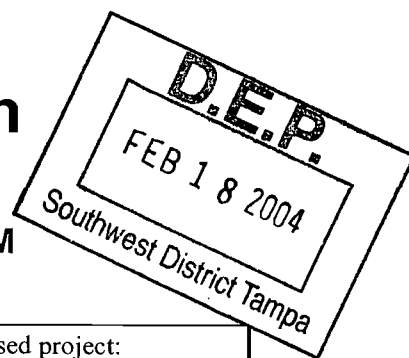

### I. APPLICATION INFORMATION

**Air Construction Permit** – Use this form to apply for an air construction permit for a proposed project:

- subject to prevention of significant deterioration (PSD) review, nonattainment area (NAA) new source review, or maximum achievable control technology (MACT) review; or
- where the applicant proposes to assume a restriction on the potential emissions of one or more pollutants to escape a federal program requirement such as PSD review, NAA new source review, Title V, or MACT; or
- at an existing federally enforceable state air operation permit (FESOP) or Title V permitted facility.

**Air Operation Permit** – Use this form to apply for:

- an initial federally enforceable state air operation permit (FESOP); or
- an initial/revised/renewal Title V air operation permit.

**Air Construction Permit & Revised/Renewal Title V Air Operation Permit (Concurrent Processing Option)**  
– Use this form to apply for both an air construction permit and a revised or renewal Title V air operation permit incorporating the proposed project.

To ensure accuracy, please see form instructions.

#### Identification of Facility

1. Facility Owner/Company Name: <b>Wheelabrator Ridge Energy Inc.</b>	
2. Site Name: <b>Ridge Generating Station</b>	
3. Facility Identification Number: <b>1050216</b>	
4. Facility Location... Street Address or Other Locator: <b>3131 K-Ville Avenue</b> City: <b>Auburndale</b> County: <b>Polk</b> Zip Code: <b>33823</b>	
5. Relocatable Facility? <input type="checkbox"/> Yes <input checked="" type="checkbox"/> No	6. Existing Title V Permitted Facility? <input checked="" type="checkbox"/> Yes <input type="checkbox"/> No

#### Application Contact

1. Application Contact Name: <b>Andrew Nguyen, Environmental Health &amp; Safety Director</b>	
2. Application Contact Mailing Address... Organization/Firm: <b>Ridge Generating Station</b> Street Address: <b>3131 K-Ville Avenue</b> City: <b>Auburndale</b> State: <b>Florida</b> Zip Code: <b>33823</b>	
3. Application Contact Telephone Numbers... Telephone: <b>( 863 ) 665 - 2255</b> ext.250            Fax: <b>( 863 ) 665 - 0400</b>	
4. Application Contact Email Address: <b>anguyen@wm.com</b>	

#### Application Processing Information (DEP Use)

1. Date of Receipt of Application:	
2. Project Number(s):	
3. PSD Number (if applicable):	

**APPLICATION INFORMATION**

4. Siting Number (if applicable):	
-----------------------------------	--

## APPLICATION INFORMATION

### Purpose of Application

**This application for air permit is submitted to obtain: (Check one)**

#### **Air Construction Permit**

Air construction permit.

#### **Air Operation Permit**

Initial Title V air operation permit.

Title V air operation permit revision.

Title V air operation permit renewal.

Initial federally enforceable state air operation permit (FESOP) where professional engineer (PE) certification is required.

Initial federally enforceable state air operation permit (FESOP) where professional engineer (PE) certification is not required.

#### **Air Construction Permit and Revised/Renewal Title V Air Operation Permit (Concurrent Processing)**

Air construction permit and Title V permit revision, incorporating the proposed project.

Air construction permit and Title V permit renewal, incorporating the proposed project.

**Note: By checking one of the above two boxes, you, the applicant, are requesting concurrent processing pursuant to Rule 62-213.405, F.A.C. In such case, you must also check the following box:**

I hereby request that the department waive the processing time requirements of the air construction permit to accommodate the processing time frames of the Title V air operation permit.

### Application Comment

**This application represents application to renew Title V Permit 1050216-001-AV and lower the HCl emission limit to bring the total emissions of hazardous air pollutants (HAPs) to less than the major source threshold.**







**APPLICATION INFORMATION**

**Professional Engineer Certification**

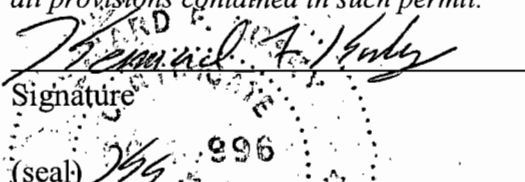
1. Professional Engineer Name: <b>Kennard F. Kosky</b> Registration Number: <b>14996</b>
2. Professional Engineer Mailing Address... Organization/Firm: <b>Golder Associates Inc.</b> Street Address: <b>6241 NW 23rd Street, Suite 500</b> City: Gainesville State: FL Zip Code: 32653-1500
3. Professional Engineer Telephone Numbers... Telephone: <b>( 352 ) 336 - 5600</b> ext. Fax: <b>( 352 ) 336 - 6603</b>
4. Professional Engineer Email Address: <b>kkosky@golder.com</b>
5. Professional Engineer Statement: <i>I, the undersigned, hereby certify, except as particularly noted herein*, that:</i> <i>(1) To the best of my knowledge, there is reasonable assurance that the air pollutant emissions unit(s) and the air pollution control equipment described in this application for air permit, when properly operated and maintained, will comply with all applicable standards for control of air pollutant emissions found in the Florida Statutes and rules of the Department of Environmental Protection; and</i> <i>(2) To the best of my knowledge, any emission estimates reported or relied on in this application are true, accurate, and complete and are either based upon reasonable techniques available for calculating emissions or, for emission estimates of hazardous air pollutants not regulated for an emissions unit addressed in this application, based solely upon the materials, information and calculations submitted with this application.</i> <i>(3) If the purpose of this application is to obtain a Title V air operation permit (check here <input checked="" type="checkbox"/> , if so), I further certify that each emissions unit described in this application for air permit, when properly operated and maintained, will comply with the applicable requirements identified in this application to which the unit is subject, except those emissions units for which a compliance plan and schedule is submitted with this application.</i> <i>(4) If the purpose of this application is to obtain an air construction permit (check here <input type="checkbox"/> , if so) or concurrently process and obtain an air construction permit and a Title V air operation permit revision or renewal for one or more proposed new or modified emissions units (check here <input checked="" type="checkbox"/> , if so), I further certify that the engineering features of each such emissions unit described in this application have been designed or examined by me or individuals under my direct supervision and found to be in conformity with sound engineering principles applicable to the control of emissions of the air pollutants characterized in this application.</i> <i>(5) If the purpose of this application is to obtain an initial air operation permit or operation permit revision or renewal for one or more newly constructed or modified emissions units (check here <input type="checkbox"/> , if so), I further certify that, with the exception of any changes detailed as part of this application, each such emissions unit has been constructed or modified in substantial accordance with the information given in the corresponding application for air construction permit and with all provisions contained in such permit.</i>  Signature: <u><i>Kennard F. Kosky</i></u> Date: <u>2/14/04</u>  (seal) 

\* Attach any exception to certification statement.



## II. FACILITY INFORMATION

### A. GENERAL FACILITY INFORMATION

#### Facility Location and Type

1. Facility UTM Coordinates... Zone 17      East (km) <b>416.7</b> North (km) <b>3100.4</b>		2. Facility Latitude/Longitude... Latitude (DD/MM/SS) Longitude (DD/MM/SS)	
3. Governmental Facility Code: <b>0</b>	4. Facility Status Code: <b>A</b>	5. Facility Major Group SIC Code: <b>49</b>	6. Facility SIC(s): <b>4911</b>
7. Facility Comment :			

#### Facility Contact

1. Facility Contact Name: <b>Andrew Nguyen, Environmental Health &amp; Safety Director</b>
2. Facility Contact Mailing Address... Organization/Firm: <b>Ridge Generating Station</b> Street Address: <b>3131 K-Ville Avenue</b> City: <b>Auburndale</b> State: <b>Florida</b> Zip Code: <b>33823</b>
3. Facility Contact Telephone Numbers: <b>( 863 ) 665 - 2255</b> ext. <b>250</b> Fax: <b>( 863 ) 665 - 0400</b>
4. Facility Contact Email Address: <b>anguyen@wm.com</b>

#### Facility Primary Responsible Official

Complete if an "application responsible official" is identified in Section I. that is not the facility "primary responsible official."

1. Facility Primary Responsible Official Name:
2. Facility Primary Responsible Official Mailing Address... Organization/Firm: <b>Ridge Generating Station</b> Street Address: <b>3131 K-Ville Avenue</b> City: <b>Auburndale</b> State: <b>Florida</b> Zip Code: <b>33823</b>
3. Facility Primary Responsible Official Telephone Numbers... Telephone: ( ) -      ext.      Fax: ( ) -
4. Facility Primary Responsible Official Email Address:

**Facility Regulatory Classifications**

Check all that would apply *following* completion of all projects and implementation of all other changes proposed in this application for air permit. Refer to instructions to distinguish between a “major source” and a “synthetic minor source.”

1. <input type="checkbox"/> Small Business Stationary Source	<input type="checkbox"/> Unknown
2. <input type="checkbox"/> Synthetic Non-Title V Source	
3. <input checked="" type="checkbox"/> Title V Source	
4. <input checked="" type="checkbox"/> Major Source of Air Pollutants, Other than Hazardous Air Pollutants (HAPs)	
5. <input type="checkbox"/> Synthetic Minor Source of Air Pollutants, Other than HAPs	
6. <input type="checkbox"/> Major Source of Hazardous Air Pollutants (HAPs)	
7. <input type="checkbox"/> Synthetic Minor Source of HAPs	
8. <input checked="" type="checkbox"/> One or More Emissions Units Subject to NSPS (40 CFR Part 60)	
9. <input type="checkbox"/> One or More Emissions Units Subject to Emission Guidelines (40 CFR Part 60)	
10. <input type="checkbox"/> One or More Emissions Units Subject to NESHAP (40 CFR Part 61 or Part 63)	
11. <input type="checkbox"/> Title V Source Solely by EPA Designation (40 CFR 70.3(a)(5))	
12. Facility Regulatory Classifications Comment:	

**List of Pollutants Emitted by Facility**

1. Pollutant Emitted	2. Pollutant Classification	3. Emissions Cap [Y or N]?
<b>SO2 - Sulfur Dioxide</b>	<b>A</b>	<b>N</b>
<b>VOC - Volatile Organic Compunds</b>	<b>B</b>	<b>N</b>
<b>PM/ PM10 - Particulate Matter</b>	<b>B</b>	<b>N</b>
<b>NOx - Nitrogen Oxides</b>	<b>A</b>	<b>N</b>
<b>CO - Carbon Monoxide</b>	<b>A</b>	<b>N</b>
<b>PB - Lead</b>	<b>B</b>	<b>N</b>
<b>H106 - Hydrogen Chloride</b>	<b>B</b>	<b>N</b>
<b>H021 - Beryllium</b>	<b>B</b>	<b>N</b>
<b>H114 - Mercury</b>	<b>B</b>	<b>N</b>
<b>SAM</b>	<b>B</b>	<b>N</b>
<b>H015-Arsenic</b>	<b>B</b>	<b>N</b>
<b>DIOX</b>	<b>B</b>	<b>N</b>
<b>H017-Benzene</b>	<b>B</b>	<b>N</b>
<b>H027-Cadmium</b>	<b>B</b>	<b>N</b>
<b>H046-Chromium</b>	<b>B</b>	<b>N</b>
<b>H150-PCB</b>	<b>B</b>	<b>N</b>



### C. FACILITY ADDITIONAL INFORMATION

#### Additional Requirements for All Applications, Except as Otherwise Stated

1. Facility Plot Plan: (Required for all permit applications, except Title V air operation permit revision applications if this information was submitted to the department within the previous five years and would not be altered as a result of the revision being sought) <input checked="" type="checkbox"/> Attached, Document ID: <b>RGS-F1-C1</b> <input type="checkbox"/> Previously Submitted, Date: _____
2. Process Flow Diagram(s): (Required for all permit applications, except Title V air operation permit revision applications if this information was submitted to the department within the previous five years and would not be altered as a result of the revision being sought) <input checked="" type="checkbox"/> Attached, Document ID: <b>RGS-F1-C2</b> <input type="checkbox"/> Previously Submitted, Date: _____
3. Precautions to Prevent Emissions of Unconfined Particulate Matter: (Required for all permit applications, except Title V air operation permit revision applications if this information was submitted to the department within the previous five years and would not be altered as a result of the revision being sought) <input checked="" type="checkbox"/> Attached, Document ID: <b>RGS-F1-C3</b> <input type="checkbox"/> Previously Submitted, Date: _____

#### Additional Requirements for Air Construction Permit Applications

1. Area Map Showing Facility Location: <input type="checkbox"/> Attached, Document ID: _____ <input checked="" type="checkbox"/> Not Applicable (existing permitted facility)
2. Description of Proposed Construction or Modification: <input checked="" type="checkbox"/> Attached, Document ID: <b>RGS-F1-C4</b>
3. Rule Applicability Analysis: <input checked="" type="checkbox"/> Attached, Document ID: <b>RGS-F1-C5</b>
4. List of Exempt Emissions Units (Rule 62-210.300(3)(a) or (b)1., F.A.C.): <input type="checkbox"/> Attached, Document ID: _____ <input checked="" type="checkbox"/> Not Applicable (no exempt units at facility)
5. Fugitive Emissions Identification (Rule 62-212.400(2), F.A.C.): <input type="checkbox"/> Attached, Document ID: _____ <input checked="" type="checkbox"/> Not Applicable
6. Preconstruction Air Quality Monitoring and Analysis (Rule 62-212.400(5)(f), F.A.C.): <input type="checkbox"/> Attached, Document ID: _____ <input checked="" type="checkbox"/> Not Applicable
7. Ambient Impact Analysis (Rule 62-212.400(5)(d), F.A.C.): <input type="checkbox"/> Attached, Document ID: _____ <input checked="" type="checkbox"/> Not Applicable
8. Air Quality Impact since 1977 (Rule 62-212.400(5)(h)5., F.A.C.): <input type="checkbox"/> Attached, Document ID: _____ <input checked="" type="checkbox"/> Not Applicable
9. Additional Impact Analyses (Rules 62-212.400(5)(e)1. and 62-212.500(4)(e), F.A.C.): <input type="checkbox"/> Attached, Document ID: _____ <input checked="" type="checkbox"/> Not Applicable
10. Alternative Analysis Requirement (Rule 62-212.500(4)(g), F.A.C.): <input type="checkbox"/> Attached, Document ID: _____ <input checked="" type="checkbox"/> Not Applicable

**Additional Requirements for FESOP Applications**

1. List of Exempt Emissions Units (Rule 62-210.300(3)(a) or (b)1., F.A.C.):  
 Attached, Document ID: \_\_\_\_\_  Not Applicable (no exempt units at facility)

**Additional Requirements for Title V Air Operation Permit Applications**

1. List of Insignificant Activities (Required for initial/renewal applications only):  
 Attached, Document ID: **RGS-F1-C6**  Not Applicable (revision application)
2. Identification of Applicable Requirements (Required for initial/renewal applications, and for revision applications if this information would be changed as a result of the revision being sought):  
 Attached, Document ID: **RGS-F1-C5**  
 Not Applicable (revision application with no change in applicable requirements)
3. Compliance Report and Plan (Required for all initial/revision/renewal applications):  
 Attached, Document ID: **RGS-F1-C7**  
Note: A compliance plan must be submitted for each emissions unit that is not in compliance with all applicable requirements at the time of application and/or at any time during application processing. The department must be notified of any changes in compliance status during application processing.
4. List of Equipment/Activities Regulated under Title VI (If applicable, required for initial/renewal applications only):  
 Attached, Document ID: \_\_\_\_\_  
 Equipment/Activities On site but Not Required to be Individually Listed  
 Not Applicable
5. Verification of Risk Management Plan Submission to EPA (If applicable, required for initial/renewal applications only) :  
 Attached, Document ID: \_\_\_\_\_  Not Applicable
6. Requested Changes to Current Title V Air Operation Permit:  
 Attached, Document ID: **RGS-F1-C4**  Not Applicable

**Additional Requirements Comment**

**ATTACHMENT RGS-F1-C1**  
**Facility Plot Plan**





**ATTACHMENT RGS-F1-C2**  
**Process Flow Diagram**



**ATTACHMENT RGS-F1-C3**  
**Precautions to Prevent Emissions of**  
**Uncontrolled Particulate Matter**

### ATTACHMENT RGS-FI-C3

#### PRECAUTIONS TO PREVENT EMISSIONS OF UNCONFINED PARTICULATE MATTER

- No person shall cause, let, permit, suffer or allow the emissions of unconfined particulate matter from any activity, including vehicular movement; transportation of materials; construction, alteration, demolition or wrecking; or industrially related activities such as loading, unloading, storing or handling; without taking reasonable precautions to prevent such emissions.
- Any permit issued to this facility with emissions of unconfined particulate matter shall specify the reasonable precautions to be taken by that facility to control the emissions of unconfined particulate matter.
- Reasonable precautions include the following:
  - Paving and maintenance of roads, parking areas and yards
  - Application of water or chemicals to control emissions from such activities as demolition of buildings, grading roads, construction, and land clearing.
  - Application of asphalt, water, oil, chemicals or other dust suppressants to unpaved roads, yards, open stock piles and similar activities.
  - Removal of particulate matter from roads and other paved areas under the control of the owner or operator of the facility to prevent re-entrainment, and from buildings or work areas to prevent particulate from becoming airborne.
  - Landscaping or planting of vegetation.
  - Use of hoods, fans, filters, and similar equipment to contain, capture and/or vent particulate matter.
  - Confining abrasive blasting where possible.
  - Enclosure or covering of conveyor systems.
- In determining what constitutes reasonable precautions for a particular source, the Department shall consider the cost of the control technique or work practice, the environmental impacts of the technique or practice, and the degree of reduction of emissions expected from a particular technique or practice.

**[Rule 62-296.320(4)(c), F.A.C.]**

- Areas that have been disturbed are revegetated
- All conveyor systems are enclosed and maintained to minimize leaks
- Facility roads are swept
- Water is applied to the truck dumps and stacker discharge
- Ash trucks are covered during transport

**ATTACHMENT RGS-F1-C4**  
**Request Changes to Current Title V Operating Permit**

Attachment RGS-F1-C4  
HCl Emission Limit Revision

The current permit limit of 5 lb/hr HCl is equivalent to 21.9 tons per year (TPY) based on 8,760 hours of operation. At the permitted emission rate, RGS is a major source of HAPs, with a single individual HAP exceeding the major threshold of 10 TPY. However the total HAP emissions are less the total HAP major threshold of 25 TPY.

Review of the last four years of compliance test results for HCl indicates that the existing HCl limitation ~~is~~<sup>is</sup> is very conservative and greatly overstates actual and potential HCl emissions. In the last four years of compliance tests, all any single one hour test runs were less than 1.0 lb/hr, or one-fifth of the permit limit. Test results are summarized in Table 1 below. The results are significantly less than the current permitted allowable emission rate due to the limited chlorine content of the fuel and the good control of HCl by the dry scrubber. Continuous control of HCl is assured by control of SO<sub>2</sub> since HCl is preferentially reacted first with the lime slurry.

Based on the test results, RGS requests a new HCl limit equal to 2.1 lb/hr and 9.2 TPY based on 8,760 hours per year. The proposed new limit of 2.1 lb/hr accounts for possible variability of uncontrolled emissions based on fuel chlorine content and dry scrubber operating conditions and will provide a conservative margin for compliance given the excellent HCl control by the dry scrubber. Based on the new HCl limit, no single individual HAP will exceed 10 TPY and the total HAPs from the facility will not exceed 25 TPY. Therefore RGS will no longer be considered a major source of HAP emissions.

Table 1. Hydrogen Chloride Compliance Test Results 2000 - 2003

Year	Compliance Test Results HCl		Current Permit	Proposed New Permit
	Run	(lb/hr)	Limit (HCl lb/hr)	Limit (HCl lb/hr)
2000	1	0.26	5.0	2.1
	2	0.14		
	3	0.09		
2001	1	0.55	5.0	2.1
	2	0.77		
	3	0.93		
2002	1	0.15	5.0	2.1
	2	0.17		
	3	0.1		
2003	1	0.22	5.0	2.1
	2	0.13		
Max		0.93		
Avg.			0.31	5.0
Max. TPY		4.07		21.9
Avg. TPY			1.34	9.2*

\* Proposed new HCl permit limit is less than the major individual HAP threshold of 10.0 TPY.

The suggested permit modification is as follows:

The RGS boiler exhaust gases shall no exceed the following limits [Rule 62-212.400, F.A.C.]:

Pollutant	lbs/hr	tons/yr	Basis for Compliance
HCl	2.1	9.2	EPA Method 26 or 26A if test required

CleanAir

CleanAir Engineering  
500 W. Wood Street  
Palatine, IL 60067-4975  
800-627-0033  
www.cleanair.com



Wheelabrator Ridge Energy  
3131 K-Ville Ave  
Auburndale, FL 33823

---

**REPORT ON COMPLIANCE TESTING**

Performed for:  
**WHEELABRATOR RIDGE ENERGY  
FABRIC FILTER OUTLET AND STACK  
AUBURNDALE, FL**

Client Reference No: 33302179  
CleanAir Project No: 9316-2  
Revision 0: June 11, 2003

---

To the best of our knowledge, the data presented in this report are accurate and complete and error free, legible and representative of the actual emissions during the test program.

Submitted by,

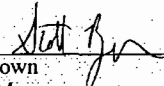
  
\_\_\_\_\_  
Scott Brown  
Project Manager

Reviewed by,

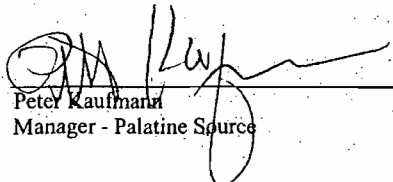
  
\_\_\_\_\_  
Peter Kaufmann  
Manager - Palatine Source



CleanAir

WHEELABRATOR RIDGE ENERGY  
AUBURNDALE, FL

Client Reference No: 33302179  
CleanAir Project No: 9316-2

**PROJECT OVERVIEW**

1-1

Wheelabrator Ridge Energy Inc. operates the Ridge Generating Station, (Facility ID No.: 1050216) located Auburndale, Florida. The facility's emission levels are regulated by the Florida Department of Environmental Protection, as well as the United States EPA.

Pursuant to Title V Air Operating Permit 1050216-001, Wheelabrator Ridge Energy, Inc. contracted Clean Air Engineering to perform compliance testing at their facility. This report details this test program. Testing was conducted in accordance with the Clean Air Protocol Dated March 11, 2003.

The testing included the determination of the following pollutants:

- particulate;
- hydrogen chloride;
- total hydrocarbons (THC, as carbon);
- visual emissions.

Coordinating the field portion of the program were:

J. Frensdorf - Wheelabrator Ridge Energy, Inc.  
M. Ambler - Clean Air Engineering

The schedule of activities is shown in Table 1-1.

**Table 1-1:  
Schedule of Activities**

Date(2003)	Constituent	Sampling Method	Run Number	Location	Start Time	End Time
April 29	Visual Emissions	EPA M9 <sup>1</sup>	1	Lime Silo Outlet	8:22	9:30
	Visual Emissions	EPA M9	1	Ash System Scrubber	10:15	11:15
	Total Hydrocarbons	EPA M25A	1	Unit 1 FF Outlet	11:02	12:02
	Particulate/HCl	EPA M5/26A <sup>2</sup>	1	Unit 1 FF Outlet	11:02	13:17
	Visual Emissions	EPA M9	1	Unit 1 FF Outlet	11:20	12:20
	Total Hydrocarbons	EPA M25A	2	Unit 1 FF Outlet	12:15	13:15
	Total Hydrocarbons	EPA M25A	3	Unit 1 FF Outlet	13:55	14:55
	Particulate/HCl	EPA M5/26A <sup>2</sup>	2	Unit 1 FF Outlet	13:55	16:31
	Visual Emissions	EPA M9	2	Unit 1 FF Outlet	15:35	16:35
April 30	Particulate/HCl	EPA M5/26A <sup>2</sup>	3	Unit 1 FF Outlet	17:45	19:58
	Visual Emissions	EPA M9	3	Unit 1 FF Outlet	17:48	18:48

<sup>1</sup> The Lime Silo opacity was observed for one-hour during a truck unloading.

<sup>2</sup> Particulate and Hydrogen chloride testing utilized EPA Method 26A with EPA Method 5 as described in EPA Method 26A Section 1.2.

## CleanAir

WHEELABRATOR RIDGE ENERGY  
AUBURNDALE, FL

Client Reference No: 33302179  
CleanAir Project No: 9316-2

### PROJECT OVERVIEW

1-2

Kevin O' Halloren of Clean Air Engineering conducted all the VE readings. Mr. O' Halloren's VE evaluation certificate is presented in Appendix H.

Three sixty-minute total hydrocarbons (THC) runs were performed. An average of the flow from concurrent Method 5/26A runs was used for the THC lb/hr emission calculations.

All process data was provided by Wheelabrator Ridge Energy, Inc. personnel. This data is presented in its entirety in Appendix C. Any process data presented in the result tables is from the average of each individual run. The mixture of fuel combusted during testing is also shown in Appendix C.

During Run 2 of the Method 5/26A train the filter popped off the frit during the sample run. A leak check was performed and the filter replaced with a new one. Both filter holders and filters were recovered. The results are consistent with Runs 1 and 3.

The boiler developed a tube leak after the second Method 5/26A Run. The tube was repaired and a third test run was done the following day.

The test conditions and results of analysis are presented in Tables 2-1 through 2-4 on pages 2-1 through 2-3. Quality control/quality assurance for the HCl analysis is presented with the laboratory results in Appendix G.

A summary of the results is presented in Table 1-2 on the following page.

CleanAir

WHEELABRATOR RIDGE ENERGY  
AUBURNDALE, FL

Client Reference No: 33302179  
CleanAir Project No: 9316-2

**PROJECT OVERVIEW**

1-3

**Table 1-2:  
Summary of Test Results**

Source Constituent	Sampling Method	Average Emission	Permit Limit <sup>1</sup>
<u>FF Outlet</u>			
PM/PM <sub>10</sub> (gr/dscf @ 7% O <sub>2</sub> )	EPA M5/26A <sup>2</sup>	0.0032	0.0080
PM/ PM <sub>10</sub> (lb/hr)	EPA M5/26A <sup>2</sup>	7.5	12.6
Hydrogen Chloride (lb/hr)	EPA M5/26A <sup>2</sup>	<0.12	5.0
Visual Emissions(percent)	EPA M9	0	10
THC as Carbon (lb/hr)	EPA M25A	5.4	22.1
<u>Lime Silo Fabric Filter Exhaust</u>			
Visual Emissions (%)	EPA M9	0	10
<u>Ash Handling System Wet Scrubber</u>			
Visual Emissions (%)	EPA M9	0	20
<u>Average Operating Conditions</u>			
Heat Input (% of each fuel)	61.7 (wood)	37.9 (tires)	0.4 (landfill gas)
Megawatts	44		
Steam Flow (lbs/hr)	341.7		
Furnace Zone Temperature (°F)	2,279		

<sup>1</sup> Limits obtained from Title V Permit# 1050216-001-AV.

<sup>2</sup> Particulate and Hydrogen chloride testing utilized EPA Method 26A with EPA Method 5 as described in EPA Method 26A Section 1.2.

**RESULTS**

**Table 2-1:  
Unit 1 FF Outlet - Particulate, Hydrogen Chloride and Opacity**

Run No.	1	2	3	Average
Date (2003)	Apr 29	Apr 29	Apr 30	
Start Time (approx.)	11:02	13:55	17:45	
Stop Time (approx.)	13:17	16:31	19:58	
<b>Process Conditions</b>				
R <sub>v</sub> Average Steam Flow (KPPH)	349.8	348.1	327.2	341.7
P <sub>1</sub> Average Stack Flow (KSCFM)	248	245	248	247
P <sub>2</sub> Average Generator Output (MW)	45	45	42	44
P <sub>3</sub> Average Furnace Temperature (°F)	2,284	2,280	2,274	2,279
P <sub>4</sub> Average Baghouse Pressure Drop (H <sub>2</sub> O)	8.1	8.7	8.1	8.4
<b>Gas Conditions</b>				
O <sub>2</sub> Oxygen (dry volume %)	11.5	11.3	12.3	11.7
CO <sub>2</sub> Carbon dioxide (dry volume %)	8.3	8.4	7.4	8.0
T <sub>s</sub> Sample temperature (°F)	223	223	220	222
B <sub>w</sub> Actual water vapor in gas (% by volume)	14.2	14.6	12.6	13.8
<b>Gas Flow Rate</b>				
Q <sub>v</sub> Volumetric flow rate, actual (acfm)	353,079	347,303	354,484	351,622
Q <sub>std</sub> Volumetric flow rate, dry standard (dscfm)	218,026	212,709	222,712	217,818
<b>Sampling Data</b>				
V <sub>std</sub> Volume metered, standard (dscf)	86.52	86.53	89.15	88.07
%I Isokinetic sampling (%)	101.4	101.8	99.9	101.0
<b>Hydrogen Chloride Laboratory Data</b>				
m <sub>h</sub> Total HCl collected (mg)	0.6822	0.4127	<0.01588	<0.3703
<b>Hydrogen Chloride (HCl) Results</b>				
C <sub>std</sub> HCl Concentration (ppmvd)	0.18	0.11	<0.0042	<0.096
C <sub>std</sub> HCl Concentration @7% O <sub>2</sub> (ppmvd)	0.14	0.086	<0.0036	<0.077
C <sub>std</sub> HCl Concentration (mg/dscm)	0.27	0.17	<0.0063	<0.15
C <sub>std</sub> HCl Concentration @7% O <sub>2</sub> (mg/dscm)	0.21	0.13	<0.0055	<0.12
E <sub>hwy</sub> HCl Rate (lb/hr)	0.22	0.13	<0.0053	<0.12
<b>Particulate Laboratory Data</b>				
m <sub>p</sub> Net matter collected (g)	0.02225	0.02453	0.02169	0.02282
<b>Particulate Results</b>				
C <sub>std</sub> Particulate Concentration (gr/dscf)	0.0039	0.0044	0.0038	0.0040
C <sub>std</sub> Particulate Concentration @7% O <sub>2</sub> (gr/dscf)	0.0031	0.0035	0.0031	0.0060
E <sub>hwy</sub> Particulate Rate (lb/hr)	7.2	8.0	7.2	7.5
<b>Visible Emissions</b>				
Start Time (approx.)	11:20	15:35	17:48	
Stop Time (approx.)	12:20	16:35	18:48	
Average (percent opacity)	0	0	0	0
Maximum reading (15 second)	0	0	0	0
Maximum average (6 minute)	0	0	0	0
No. of readings >10% (15 second)	0	0	0	0

CleanAir

WHEELABRATOR RIDGE ENERGY  
AUBURNDALE, FL

Client Reference No: 33302179  
Clean Air Project No: 9316-2

**RESULTS**

2-2

**Table 2-2:  
Unit 1 FF Outlet - Total Hydrocarbons**

Run No.	1	2	3	Average
Date (2003)	April 29	April 29	April 29	
Start Time (approx.)	11:02	12:15	13:55	
Stop Time (approx.)	12:02	13:15	14:55	
<b>Process Condition</b>				
R <sub>p</sub> Average Steam Flow (KPPH)	349.8	349.8	348.1	341.7
P <sub>1</sub> Average Stack Flow (KSCFM)	248	248	245	247
P <sub>2</sub> Average Generator Output (MW)	45	45	45	45
P <sub>3</sub> Average Furnace Temperature (°F)	2,284	2,284	2,280	2,279
P <sub>4</sub> Average Baghouse Pressure Drop (H <sub>2</sub> O)	9.1	9.1	9.8	9.4
<b>Gas Conditions<sup>1</sup></b>				
T <sub>s</sub> Temperature (°F)	223	223	220	222
B <sub>w</sub> Moisture (volume %)	14.2	14.2	14.6	14.3
Q <sub>std</sub> Standard conditions (dscfm)	218,026	218,026	212,709	216,254
<b>Oxygen</b>				
C Concentration (%)	11.5	11.5	11.3	11.4
<b>Carbon Dioxide</b>				
C Concentration (%)	8.5	8.4	8.6	8.5
<b>TOTAL HYDROCARBONS (as Carbon)</b>				
C Concentration (ppmdv)	9.5	13.2	7.1	9.9
C Concentration (ppmwv)	8.1	11.3	6.1	8.5
E Emission rate (lb/hr)	5.2	7.2	3.8	5.4

<sup>1</sup> Gas conditions obtained from concurrent Method 5/202 testing.

CleanAir

WHEELABRATOR RIDGE ENERGY  
AUBURNDALE, FL

Client Reference No: 33302179  
Clean Air Project No: 9316-2

**RESULTS**

2-3

**Table 2-3:  
Lime Silo - Opacity**

Run No.	1	Average
Date (2003)	Apr 29	
Start Time (approx.)	08:22	
Stop Time (approx.)	09:30	
<u>Process Conditions</u>		
Lime Unloaded (tons)	25.9	
Total Unloading Time (hours)	1.53	
Rate of Unloading (tons/hr)	16.93	
<u>Visible Emissions</u>		
Average (percent opacity)	0	0
Maximum Reading (15 second)	0	0
Maximum Average (6 minute)	0	0
No. of Readings >10% (15 second)	0	0

**Table 2-4:  
Ash Handling System Wet Scrubber - Opacity**

Run No.	1	Average
Date (2003)	Apr 29	
Start Time (approx.)	10:15	
Stop Time (approx.)	11:15	
<u>Visible Emissions</u>		
Average (percent opacity)	0	0
Maximum Reading (15 second)	0	0
Maximum Average (6 minute)	0	0
No. of Readings >20% (15 second)	0	0

**Ridge Generating Station**  
 Compliance Test Fuel Consumption & Heat Input Summary  
 April 29 & 30, 2003  
 Permit # 1050216-001-AV

Fuel Burned in Tons					BTU Input by Fuel				Facility Summary					
Total Tons Burned from Day from 00:00 to 23:59					Daily Average from 00:00 to 23:59				Daily Average from 00:00 to 23:59					
Test Date	Wood Burned	Tires Burned	Landfill Gas Burned	Propane Burned	BTU Input Wood	BTU Input Tires	BTU Input Landfill Gas	BTU Input Propane	Total BTU Input	MMBTU Input Hour Operation	Capacity Factor	Total Magawatts	Percentage Tires by BTU	Percentage Tires by Weight
04/29/03	774.0	178.0	47.3	0.0	8049600000	5357444000	45408000	0	13452452000	560.52	88.97%	582	39.83%	17.81%
04/30/03	521.0	97.0	34.8	0.0	5418400000	2919506000	33408000	0	8371314000	348.80	55.37%	370	34.88%	14.86%

BTU Heating Values  
 Tires - 15049 btu/pound  
 Wood - 5200 btu/pound  
 Landfill Gas - 480 btu/pound  
 Propane - 21670 btu/pound

Note: Tube leak occurred on 04-29 and boiler taken off line @ ~22:00. Boiler back on line @ ~08:00 on 04-30.  
 Capacity factor based upon 24 hours operation and does not account for difficulties and reduced loads associated with tube repair.

Totals:  $1.3468 \times 10^9$      $8.27695 \times 10^8$      $7.888 \times 10^7$      $2.1823766 \times 10^{10}$   
 (%)    61.71%    37.93%    0.36%

CleanAir

CleanAir Engineering  
500 W. Wood Street  
Palatine, IL 60067-4975  
800-627-0033  
www.cleanair.com



Wheelabrator Ridge Energy, Inc.  
3131 K-Ville Ave  
Auburndale, Florida 33823

---

**REPORT ON COMPLIANCE TESTING**

Performed for:  
**WHEELABRATOR RIDGE ENERGY, INC.  
UNIT 1 FABRIC FILTER OUTLET AND STACK  
AUBURNDALE, FLORIDA**

Client Reference No:  
Clean Air Project No: 9119-1  
Revision 0: May 16, ~~2001~~ 2002

---

To the best of our knowledge, the data presented in this report are accurate and complete.

Submitted by,

  
\_\_\_\_\_  
Scott Brown  
Project Manager  
(847)991-6200 ext. 2044

Reviewed by,

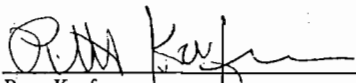
  
\_\_\_\_\_  
Peter Kaufmann  
Manager Palatine Source



CleanAir

WHEELABRATOR RIDGE ENERGY, INC.  
AUBURNDALE, FLORIDA

Client Reference No:  
Clean Air Project No: 9119-1

**PROJECT OVERVIEW**

1-1

Wheelabrator Ridge Energy Inc. operates the Ridge Generating Station, (Facility ID No.: 1050216) located Auburndale, Florida. The facility's emission levels are regulated by the Florida Department of Environmental Protection, as well as the United States EPA.

Pursuant to Title V Air Operating Permit 1050216-001, Wheelabrator Ridge Energy, Inc. contracted Clean Air Engineering to perform compliance testing at their facility. This report details this test program. Testing was conducted in accordance with Clean Air Protocol No: 8859P, Dated March 18, 2002.

The testing included the determination of the following pollutants:

- particulate;
- hydrogen chloride;
- total hydrocarbons as carbon;
- visual emissions.

Coordinating the field portion of the program were:

J. Frensdorf - Wheelabrator Ridge Energy, Inc.  
R. Ship - Clean Air Engineering

The schedule of activities is shown in Table 1-1:

Table 1-1:  
Schedule of Activities

Date(2002)	Constituent	Sampling Method	Run Number	Location	Start Time	End Time
April 23	Particulate/HCl	EPA M5/26A <sup>1</sup>	1	Unit 1 FF Outlet	8:18	10:32
	Visual Emissions	EPA M9	1	Unit 1 FF Outlet	8:38	9:38
	Total Hydrocarbons	EPA M25A	1	Unit 1 FF Outlet	9:11	10:11
	Visual Emissions	EPA M9 <sup>2</sup>	2	Lime Silo Outlet	9:45	10:45
	Particulate/HCl	EPA M5/26A <sup>1</sup>	2	Unit 1 FF Outlet	11:00	13:11
	Total Hydrocarbons	EPA M25A	2	Unit 1 FF Outlet	11:08	12:08
	Visual Emissions	EPA M9	2	Unit 1 FF Outlet	11:42	12:42
	Total Hydrocarbons	EPA M25A	2	Unit 1 FF Outlet	13:37	14:37
	Particulate/HCl	EPA M5/26A <sup>1</sup>	3	Unit 1 FF Outlet	13:41	15:51
	Total Hydrocarbons	EPA M25A	3	Unit 1 FF Outlet	13:42	14:42
	Visual Emissions	EPA M9	3	Ash System Scrubber	13:45	14:45
	Visual Emissions	EPA M9	3	Unit 1 FF Outlet	14:49	15:49

<sup>1</sup> Particulate and Hydrogen chloride testing utilized EPA Method 26A with EPA Method 5 as described in EPA Method 26A Section 1.2.

<sup>2</sup> The Lime Silo opacity was observed for one-hour during a truck unloading.

**PROJECT OVERVIEW**

1-3

**Table 1-2:  
 Summary of Test Results**

Source Constituent	Sampling Method	Average Emission	Permit Limit <sup>1</sup>
<b>FF Outlet</b>			
PM/PM <sub>10</sub> (gr/dscf @ 7% O <sub>2</sub> )	EPA M5/26A <sup>2</sup>	0.0014	0.0080
PM/PM <sub>10</sub> (lb/hr)	EPA M5/26A <sup>2</sup>	1.6	12.6
Hydrogen Chloride (lb/hr)	EPA M5/26A <sup>2</sup>	0.14	5.0
Visual Emissions(percent)	EPA M9	0	10
VOC as Carbon (lb/hr)	EPA M25A	13.1	22.1
<b>Lime Silo Fabric Filter Exhaust</b>			
Visual Emissions (%)	EPA M9	0	10
<b>Ash Handling System Wet Scrubber</b>			
Visual Emissions (%)	EPA M9	0	20
<b>Average Operating Conditions<sup>3</sup></b>			
Heat Input (% of each fuel)	65.8 (wood)	33.9 (tires)	0.3 (landfill gas)
Megawatts	45		
Steam Flow (lbs/hr)	358		
Furnace Zone Temperature (°F)	2240		

<sup>1</sup> Limits obtained from Title V Permit# 1050216-001-AV.

<sup>2</sup> Particulate and Hydrogen chloride testing utilized EPA Method 26A with EPA Method 5 as described in EPA Method 26A Section 1.2.

<sup>3</sup> Average operating conditions taken from Method 5/26A sampling.

*CleanAir*

WHEELABRATOR RIDGE ENERGY, INC.  
AUBURNDALE, FLORIDA

Client Reference No:  
Clean Air Project No: 9119-1

**PROJECT OVERVIEW**

1-2

Jim Burton of Clean Air Engineering conducted all the VE readings. Mr. Burton's VE evaluation certificate is presented in Appendix H.

Three sixty-minute total hydrocarbons (THC) runs were performed. An average of the flow from concurrent Method 5/26A runs was used for lb/hr emission calculations.

All process data was provided by Wheelabrator Ridge Energy, Inc. personnel. This data is presented in its entirety in Appendix C. Any process data presented in the result tables is from the average of each individual run. The mixture of fuel combusted during testing is also shown in Appendix C.

The test conditions and results of analysis are presented in Tables 2-1 through 2-4 on pages 2-1 through 2-3. Quality control/quality assurance for the HCl analysis is presented with the laboratory results in Appendix G.

A summary of the results is presented in Table 1-2 on page 1-3.

Revision 0

**RESULTS**

2-1

**Table 2-1:  
 Unit 1 FF Outlet - Particulate, Hydrogen Chloride and Opacity**

Run No.	1	2	3	Average
Date (2002)	April 23	April 23	April 23	
Start Time (approx.)	08:18	11:00	13:41	
Stop Time (approx.)	10:32	13:11	15:51	
<b>Process Condition</b>				
Average Stack Flow (KSCFM)	227	224	222	224
Average Generator Output (MW)	45.4	43.7	45.9	45.0
Average Furnace Temperature (°F)	2238	2241	2241	2240
Average Steam Flow (KPPH)	361	347	365	358
<b>Gas Conditions</b>				
O <sub>2</sub> Oxygen (dry volume %)	12.1	12.4	11.7	12.1
CO <sub>2</sub> Carbon dioxide (dry volume %)	7.7	7.4	7.9	7.7
T <sub>g</sub> Temperature (°F)	222	219	211	218
B <sub>ws</sub> Moisture (volume %)	11.5	11.2	12.0	11.6
<b>Test Conditions</b>				
V <sub>mstd</sub> Volume metered, standard (ft <sup>3</sup> )	89.46	90.98	89.94	90.13
V <sub>mstd</sub> Volume metered, standard (m <sup>3</sup> )	2.53	2.58	2.55	2.55
%I Isokinetic sampling (%)	98.9	100.5	102.1	100.5
<b>Volumetric Flow Rate</b>				
Q <sub>a</sub> Actual conditions (acfm)	339,000	336,100	328,700	334,600
Q <sub>std</sub> Standard conditions (dscfm)	216,600	216,800	211,100	214,800
<b>Particulate</b>				
m <sub>s</sub> Matter collected (g)	0.0037	0.0087	0.0027	0.0050
C Concentration (gr/acf)	0.00041	0.00095	0.00030	0.00055
C Concentration (gr/dscf)	0.00064	0.0015	0.00046	0.00086
C Concentration (gr/dscf @ 7% O <sub>2</sub> )	0.00064	0.0015	0.00046	0.00086
E Emission rate (lb/hr)	1.2	2.7	0.84	1.6
<b>Hydrogen Chloride</b>				
C Concentration (lb/dscf)	1.14E-08	1.32E-08	8.07E-09	1.09E-08
C Concentration (ppmdv)	0.12	0.14	0.085	0.12
C Concentration (ppm @ 7% O <sub>2</sub> )	0.19	0.23	0.13	0.18
E Emission rate (lb/hr)	0.154	0.17	0.103	0.147
E Emission rate (lb/10 <sup>6</sup> Btu)	0.00026	0.00031	0.00018	0.00025
Start Time (approx.)	08:38	11:42	14:49	
Stop Time (approx.)	09:38	12:42	15:49	
<b>Visible Emissions (%)</b>				
Average opacity (1 hour)	0	0	0	0
Maximum reading (15 second)	0	0	0	0
Maximum average (6 minute)	0	0	0	0
No. of readings >20% (15 second)	0	0	0	0

CleanAir

WHEELABRATOR RIDGE ENERGY, INC.  
AUBURNDALE, FLORIDA

Client Reference No:  
Clean Air Project No: 9119-1

**RESULTS**

2-2

**Table 2-2:**  
**Unit 1 FF Outlet - Total Hydrocarbons**

Run No.	1	2	3	Average
Date (2002)	April 23	April 23	April 23	
Start Time (approx.)	09:11	11:08	13:42	
Stop Time (approx.)	10:11	12:08	14:42	
<b>Process Condition</b>				
Average Stack Flow (KSCFM)	227	225	224	225
Average Generator Output (MW)	45.3	43.4	46.9	44.9
Average Furnace Temperature (°F)	2229	2233	2238	2233
Average Steam Flow (KPPH)	362	346	365	357
<b>Gas Conditions<sup>1</sup></b>				
B <sub>std</sub> Moisture (volume %)	11.5	11.2	11.6	11.4
Q <sub>std</sub> Standard conditions (dscfm)	216,800	216,800	211,100	214,833
O <sub>2</sub> Oxygen (dry volume %)	12.1	12.4	11.7	12.1
CO <sub>2</sub> Carbon dioxide (dry volume %)	7.7	7.4	7.9	7.7
<b>Total Hydrocarbons (as carbon)</b>				
C <sub>gm</sub> Concentration drift corrected (ppmwv)	22.8	11.6	51.8	28.7
C <sub>pm</sub> Concentration moisture corrected (ppmdv)	25.7	13.1	58.5	32.4
C <sub>ppm</sub> Concentration corrected to 7% O2 (ppm)	35.1	18.4	77.0	43.5
E Emission rate (lb/hr)	10.4	5.3	23.1	12.9

<sup>1</sup> Moisture and flow data obtained from concurrent Method 5/26A testing.

**RESULTS**

2-3

**Table 2-3:  
 Lime Silo - Opacity**

Source Run No.	Lime Silo Vent 1
Date (2002)	April 23
Start Time (approx.)	9:45
Stop Time (approx.)	10:45
<b>Process Conditions</b>	
Lime unloaded (tons)	26.8
Total Unloading Time (hours)	1.85
Rate of unloading (tons/hour)	14.5
<b>Visible Emissions</b>	
Average (percent opacity)	0
Maximum reading (percent opacity)	0

**Table 2-4:  
 Ash Handling System Wet Scrubber - Opacity**

Run No.	1	Average
Date (2002)	April 23	
Start Time (approx.)	13:45	
Stop Time (approx.)	14:45	
<b>Visible Emissions (%)</b>		
Average opacity (1 hour)	0	0
Maximum reading (15 second)	0	0
Maximum average (6 minute)	0	0
No. of readings >20% (15 second)	0	0



500 W. Wood St. • Palatine, IL 60067 • 847-991-3300

Fax: 847-991-3385  
Internet: www.claenair.com

Wheelabrator Ridge Energy, Inc.  
3131 K-Ville Ave  
Auburndale, Florida 33823

---

**REPORT ON COMPLIANCE TESTING**

Performed for:  
**WHEELABRATOR RIDGE ENERGY, INC.**  
**UNIT 1 FABRIC FILTER OUTLET AND STACK**  
**AUBURNDALE, FLORIDA**

Client Reference No:  
CAE Project No: 8859-1  
Revision 0: May 8, 2001

---

To the best of our knowledge, the data presented in this report are accurate and complete.

Submitted by:

Reviewed by:

  
\_\_\_\_\_  
Scott Brown  
Project Manager  
(847)991-6200 ext. 2044

  
\_\_\_\_\_  
Bill Ansell  
Project Manager

**PROJECT OVERVIEW**

1-1

Wheelabrator Ridge Energy Inc. operates the Ridge Generating Station, (Facility ID No.: 1050216) located Auburndale, Florida. The facility's emission levels are regulated by the Florida Department of Environmental Protection, as well as the United States EPA.

Pursuant to Title V Air Operating Permit 1050216-001, Wheelabrator Ridge Energy, Inc. contracted Clean Air Engineering to perform compliance testing at their facility. This report details this test program. Testing was conducted in accordance with CAE Protocol No: 8859P, Dated February 16, 2001.

The testing included the determination of the following pollutants:

- particulate;
- hydrogen chloride;
- total hydrocarbons as carbon;
- visual emissions.

Coordinating the field portion of the program were:

J. Neil - Wheelabrator Ridge Energy, Inc.  
B. Penar - Clean Air Engineering

The schedule of activities is shown in Table 1-1.

**Table 1-1:  
Schedule of Activities**

Date(2001)	Constituent	Sampling Method	Run Number	Location	Start Time	End Time
April 2	Visual Emissions	EPA M9	1	Ash Handling System Wet Scrubber	13:29	14:29
April 3	Particulate/HCl	EPA M5/26A <sup>1</sup>	1	Unit 1 FF Outlet	9:57	12:13
	Visual Emissions	EPA M9	1	Unit 1 FF Stack Outlet	10:07	11:07
	Visual Emissions	EPA M9 <sup>1</sup>	2	Lime Silo Outlet	10:10	11:42
	Total Hydrocarbons	EPA M25A	1	Unit 1 FF Outlet	10:16	11:16
	Particulate/HCl	EPA M5/26A <sup>1</sup>	2	Unit 1 FF Outlet	13:31	16:41
	Visual Emissions	EPA M9	1	Unit 1 FF Stack Outlet	13:35	14:35
	Total Hydrocarbons	EPA M25A	2	Unit 1 FF Outlet	13:37	14:37
	Particulate/HCl	EPA M5/26A <sup>1</sup>	3	Unit 1 FF Outlet	16:52	19:05
	Total Hydrocarbons	EPA M25A	3	Unit 1 FF Outlet	16:56	17:56
	Visual Emissions	EPA M9	3	Unit 1 Stack Outlet	17:30	18:30

<sup>1</sup> Particulate and Hydrogen chloride testing utilized EPA Method 26A with EPA Method 5 as described in EPA Method 26A Section 1.2.



**PROJECT OVERVIEW**

1-2

Particulate sampling (EPA Method 5) was combined with the hydrogen chloride testing (EPA Method 26A) as referenced in Method 26A Section 1.2 Principle, "If desired, the particulate matter recovered from the filter and the probe is analyzed following the procedures in Method 5." The probe and filter box for these trains were maintained at 248 °F +/- 25 °F.

Three sixty-minute total hydrocarbons (THC) runs were performed. An average of the flow from concurrent Method 5/26A runs were used for lb/hr emission calculations.

All process data was provided by Wheelabrator Ridge Energy, Inc. personnel. This data is presented in its entirety in Appendix G. Any process data presented in the result tables is from the average of each individual run. The mixture of fuel combusted during testing is also shown in Appendix G.

A summary of the results is presented in the following Table 1-2.

Table 1-2:  
Summary of Test Results

Source Constituent	Sampling Method	Average Emission	Permit Limit <sup>1</sup>
<u>Unit 1</u>			
PM/PM <sub>10</sub> (gr/dscf @ 7% O <sub>2</sub> )	EPA M5/26A <sup>2</sup>	0.0025	0.0080
Hydrogen Chloride (lb/hr)	EPA M5/26A <sup>2</sup>	0.75	5.0
Visual Emissions (percent)	EPA M9	0	10
VOC as Carbon (lb/hr)	EPA M25A	13.6	22.1
<u>Lime Silo Fabric Filter Exhaust</u>			
Visual Emissions (%)	EPA M9	0	10
<u>Ash Handling System Wet Scrubber</u>			
Visual Emissions (%)	EPA M9	0	20

<sup>1</sup> Limits obtained from Title V Permit# 1050218-001-AV.

<sup>2</sup> Particulate and Hydrogen chloride testing utilized EPA Method 26A with EPA Method 5 as described in EPA Method 26A Section 1.2.

The test conditions and results of analysis are presented in Tables 2-1 through 2-4 on pages 2-1 through 2-3. Quality control/quality assurance for the HCl analysis is presented with the laboratory results in Appendix F.

Revision 0



**RESULTS**

2-1

**Table 2-1:  
Unit 1 FF Outlet - Particulate, Hydrogen Chloride and Opacity**

Run No.	1	2	3	Average
Date (2001)	April 3	April 3	April 3	
Start Time (approx.)	09:57	13:31	16:52	
Stop Time (approx.)	12:13	16:41	19:05	
<b>Process Data<sup>1</sup></b>				
Average Generator Output (megawatts)	45.1	45.3	45.0	45.1
Average Steam Flow (Klbs/hr)	370.3	370.8	366.0	369.0
Average Stack Flow (Kscfm)	214	213	203	210
Average Furnace Temperature (°F)	2320	2288	2261	2290
Average Opacity (%)	0.003	0.003	0.003	0.003
Baghouse Pressure Differential (H <sub>2</sub> O)	0.003	0.003	0.003	0.003
<b>Gas Conditions</b>				
O <sub>2</sub> Oxygen (dry volume %)	10.7	11.1	11.2	11.0
CO <sub>2</sub> Carbon dioxide (dry volume %)	7.6	8.0	8.0	7.9
T <sub>g</sub> Temperature (°F)	219	234	237	230
B <sub>w</sub> Moisture (volume %)	14.4	13.0	12.1	13.2
<b>Volumetric Flow Rate</b>				
Q <sub>g</sub> Actual conditions (acfm)	325,900	330,100	332,500	329,500
Q <sub>std</sub> Standard conditions (dscfm)	202,800	209,500	207,400	206,600
<b>Front Half Particulate</b>				
C Concentration (gr/acf)	0.00081	0.0016	0.00087	0.0011
C Concentration (gr/dscf)	0.0013	0.0026	0.0014	0.0018
C Corrected to 7% O <sub>2</sub> (gr/dscf)	0.0018	0.0036	0.0020	0.0025
C Corrected to 12% CO <sub>2</sub> (gr/dscf)	0.0021	0.0039	0.0021	0.0027
E Emission rate (lb/hr)	2.3	4.6	2.5	3.1
E Emission rate by F <sub>d</sub> (lb/10 <sup>6</sup> Btu)	0.0036	0.0075	0.0041	0.0051
<b>Hydrogen Chloride</b>				
C Concentration (lb/dscf)	4.49E-08	8.12E-08	7.51E-08	6.04E-08
C Concentration (ppmdv)	0.47	0.65	0.79	0.64
C Concentration (ppm @ 7% O <sub>2</sub> )	0.65	0.92	1.14	0.90
C Concentration (ppm @ 12% CO <sub>2</sub> )	0.75	0.97	1.19	0.97
C Concentration (mg/dscfm)	0.72	0.98	1.20	1.0
E Emission rate (lb/hr)	0.55	0.77	0.93	0.75
E Emission rate (lb/10 <sup>6</sup> Btu)	8.81E-04	1.25E-03	1.55E-03	1.23E-03
<b>Visible Emissions</b>				
Start Time (approx.)	10:07	13:35	17:30	
Stop Time (approx.)	11:07	14:35	18:30	
Average opacity (1 hour)	0	0	0	0
Maximum reading (15 second)	0	0	0	0
Maximum average (6 minute)	0	0	0	0
No. of readings >20% (15 second)	0	0	0	0

<sup>1</sup> Process Data was supplied by Wheelabrator Ridge Energy, Inc. personnel.

**RESULTS**

2-2

**Table 2-2:  
Unit 1 FF Outlet - Total Hydrocarbons**

Run No.	1	2	3	Average
Date	April 3	April 3	April 3	
Start Time (approx.)	10:16	13:37	16:56	
Stop Time (approx.)	11:16	14:37	17:56	
<b>Process Conditions<sup>1</sup></b>				
Average Generator Output (megawatts)	44.6	45.3	44.9	44.9
Average Steam Flow (Klbs/hr)	366.7	370.9	365.5	367.7
Average Stack Flow (Kscfm)	215	213	201	210
Average Furnace Temperature (°F)	2324	2289	2268	2294
Average Opacity (%)	0.03	0.17	0.81	0.34
<b>Gas Conditions<sup>2</sup></b>				
T <sub>g</sub> Temperature (°F)	219	234	237	230
O <sub>2</sub> Oxygen (dry volume %)	10.9	11.0	10.9	10.9
CO <sub>2</sub> Carbon Dioxide (dry volume %)	8.7	8.5	8.5	8.5
B <sub>ws</sub> Moisture (volume %)	14.4	13.0	12.1	13.2
Q <sub>std</sub> Standard conditions (dscfm)	202,800	209,500	207,400	206,567
<b>Total Hydrocarbon (as carbon)</b>				
C Concentration (ppm <sub>v</sub> as carbon)	43.0	26.8	36.3	35.4
C Concentration (ppm <sub>w</sub> as carbon)	50.2	30.8	41.3	40.8
C Concentration (ppm @ 7% O <sub>2</sub> )	59.8	37.3	50.4	49.2
C Concentration as carbon (ppm @ .12% CO <sub>2</sub> )	59.3	37.0	50.0	48.8
E Emission rate (lb/hr)	16.3	10.5	14.1	13.6

<sup>1</sup> Process Data was supplied by Wheelabrator Ridge Energy, Inc. personnel.

<sup>2</sup> Gas conditions obtained from concurrent Method 5/26A testing.

Revision 0



**RESULTS**

2-3

**Table 2-3:  
 Lime Silo - Opacity**

Run No.	1	Average
Date (2001)	April 3	
Start Time (approx.)	10:10	
Stop Time (approx.)	11:42	
<b>Process Conditions</b>		
Quantity of Lime Transferred (lbs)	51,880	
Time to Transfer Lime (minutes)	93	
Transfer Rate (lbs/hr)	33,470	
Transfer Rate (tons/hr)	16.74	
Fabric Filter Pressure Differential (" H <sub>2</sub> O)	9.8	
<b>Visible Emissions (%)</b>		
Average opacity (1 hour)	0	0
Maximum reading (15 second)	5	5
Maximum average (6 minute)	0	0
No. of readings >20% (15 second)	0	0

**Table 2-4:  
 Ash Handling System Wet Scrubber - Opacity**

Run No.	1
Date (2001)	April 2
Start Time (approx.)	13:29
Stop Time (approx.)	14:29
<b>Visible Emissions (%)</b>	
Average opacity (1 hour)	0
Maximum reading (15 second)	0
Maximum average (6 minute)	0
No. of readings >20% (15 second)	0

Revision 0





500 W. Wood St. • Palatine, IL 60067 • 847-991-3300

Fax: 847-991-3385  
Internet: www.cleanair.com

Wheelabrator Ridge Energy, Inc.  
3131 K-Ville Ave  
Auburndale, Florida 33823

---

**REPORT ON COMPLIANCE TESTING**

Performed for:  
**WHEELABRATOR RIDGE ENERGY, INC.**  
**UNIT 1 FABRIC FILTER OUTLET AND STACK**  
**AUBURNDALE, FLORIDA**

Client Reference No:  
CAE Project No: 8720-1  
Revision 0: September 12, 2000

---

To the best of our knowledge, the data presented in this report are accurate and complete.

Submitted by,

Reviewed by,

  
\_\_\_\_\_  
Scott Brown  
Project Manager  
(847)991-6200 ext. 2044

  
\_\_\_\_\_  
Mark Roach  
Project Manager

WHEELABRATOR RIDGE ENERGY, INC.  
AUBURNDALE, FLORIDA

Client Reference No:  
CAE Project No: 8720-1

## PROJECT OVERVIEW

1-1

Wheelabrator Ridge Energy Inc. operates the Ridge Generating Station, (Facility ID No.: 1050046) located Auburndale, Florida. The facility's emission levels are regulated by the Florida Department of Environmental Protection, as well as the United States EPA.

Pursuant to Title V Air Operating Permit number 1050216-001-AV, Wheelabrator Ridge Energy, Inc. contracted Clean Air Engineering to perform compliance testing at their facility. This report details this test program. Testing was conducted in accordance with CAE Protocol No: 8720P: Dated July 5, 2000.

The testing included the determination of the following pollutants:

- particulate;
- beryllium;
- lead;
- mercury;
- hydrogen chloride;
- total hydrocarbons as carbon;
- visual emissions.

Coordinating the field portion of the program were:

J. Neil - Wheelabrator Ridge Energy, Inc.  
S. Brown - Clean Air Engineering

The schedule of activities is shown in Table 1-1 on page 1-2.

Revision 0



**PROJECT OVERVIEW**

1-2

**Table 1-1:  
Schedule of Activities**

Date(2000)	Constituent	Sampling Method	Run Number <sup>1</sup>	Location	Start Time	End Time
August 11	Visual Emissions	EPA M9	1	Unit 1 FF Stack Outlet	9:40	10:40
	Particulate/HCl	EPA M5/26A <sup>2</sup>	1	Unit 1 FF Outlet	9:42	12:00
	Metals	EPA M29	1	Unit 1 FF Outlet	9:42	12:00
	Total Hydrocarbons	EPA M25A	1	Unit 1 FF Outlet	9:42	10:41
	Visual Emissions	EPA M9	1	Lime Silo Outlet	10:50	11:20
	Total Hydrocarbons	EPA M25A	2	Unit 1 FF Outlet	11:13	12:12
	Total Hydrocarbons	EPA M25A	3	Unit 1 FF Outlet	12:47	N.C. <sup>3</sup>
	Particulate/HCl	EPA M5/26A <sup>2</sup>	2	Unit 1 FF Outlet	12:56	N.C. <sup>3</sup>
	Metals	EPA M29	2	Unit 1 FF Outlet	12:56	N.C. <sup>3</sup>
	Visual Emissions	EPA M9 <sup>1</sup>	2	Unit 1 Stack Outlet	13:05	14:05
	Particulate/HCl	EPA M5/26A <sup>2</sup>	3	Unit 1 FF Outlet	16:52	19:09
	Metals	EPA M29	3	Unit 1 FF Outlet	16:52	19:09
	Total Hydrocarbons	EPA M25A	4	Unit 1 FF Outlet	16:57	17:56
	Visual Emissions	EPA M9	3	Unit 1 Stack Outlet	17:50	18:50
	Particulate/HCl	EPA M5/26A <sup>2</sup>	4	Unit 1 FF Outlet	19:58	22:14
	Metals	EPA M29	4	Unit 1 FF Outlet	19:58	22:14

<sup>1</sup> Method 9 could not be performed during Method 5/26A, Run 4, due to darkness. Method 9, Run 2, performed during aborted Run 2 of Method 5/26A was used for compliance.

<sup>2</sup> Particulate and Hydrogen chloride testing utilized EPA Method 26A with EPA Method 5 as described in EPA Method 26A Section 1.2.

<sup>3</sup> N.C. refers to not completed; these runs were not finished due to process upsets, particularly that the Unit was not able to maintain the >90% load that is required for compliance testing.



## PROJECT OVERVIEW

1-3

The mercury analyses that were reported as not detected were summed into the total mercury results using the detection limit. When one or more fractions were detectable a less than sign was used and the values reported are considered the maximum possible concentration/emission rate (see Runs 1 and 4). When all analyses were non-detects a ND was used and the detection limit is shown in parenthesis for each fraction and the total mercury (see Run 3). The results of the Method 29 reagent blank analysis were used to correct any data as outlined in Method 29. The results are presented in Table 2-6 on page 2-6.

Particulate sampling (EPA Method 5) was combined with the hydrogen chloride testing (EPA Method 26A) as referenced in Method 26A Section 1.2 Principle. "If desired, the particulate matter recovered from the filter and the probe is analyzed following the procedures in Method 5." The probe and filter box for these trains were maintained at 248 °F +/- 25 ° F.

Three sixty-minute total hydrocarbons (THC) runs were performed. An average of the flow from the Method 5/26A and Method 29 Runs 1 (THC Runs 1 and 2) and 3 (THC Run 4) were used for lb/hr emission calculations.

There was one major process upsets that occurred during the testing that resulted in aborting the wet methods (both Method 29 and 5/26A) Run 2 and the THC Run 3. The tire feeder and grate failure upset caused the plant to drop below the 90% load (<45 mW) that must be maintained during compliance testing.

All process data was provided by Wheelabrator Ridge Energy, Inc. personnel. This data is presented in its entirety in Appendix H. Any process data presented in the result tables is from the average of each individual run. The mixture of fuel combusted during testing is also shown in Appendix H.

A summary of the results is presented in Table 1-2 on page 1-4.





**PROJECT OVERVIEW**

1-4

**Table 1-2:  
 Summary of Test Results**

Source Constituent	Sampling Method	Average Emission <sup>1</sup>	Permit Limit <sup>1</sup>
<b>Unit 1</b>			
PM/PM <sub>10</sub> (gr/dscf @ 7% O <sub>2</sub> )	EPA M5/26A <sup>2</sup>	0.0035	0.0060
Hydrogen Chloride (lb/hr)	EPA M5/26A <sup>2</sup>	0.16	5.0
Visual Emissions(percent)	EPA M9	0	10
Beryllium (lb/hr)	EPA M29	ND(0.0000307)	0.0063
Lead(lb/hr)		0.0011	0.25
Mercury(lb/hr)		<0.00024	0.022
VOC as Carbon (lb/hr)	EPA M25A	9.4	22.1
<b>Lime Silo Fabric Filter Exhaust</b>			
Visual Emissions (%)	EPA M9	5	10

<sup>1</sup> Limits obtained from Title V Air Operating Permit number 1050216-001-AV.  
<sup>2</sup> All wet method averages are from Runs 1, 3 and 4. The THC averages are from Runs 1,2 and 4 and the Visual Emissions averages are from Runs 1-3.  
<sup>3</sup> Particulate and Hydrogen chloride testing utilized EPA Method 26A with EPA Method 5 as described in EPA Method 26A Section 1.2.  
 ND - Indicates the constituent was not detected. The detection limit is shown in parenthesis.

The test conditions, results of analysis and quality assurance/quality control results are presented in Tables 2-1 through Table 2-6 on pages 2-1 through 2-6.



WHEELABRATOR RIDGE ENERGY, INC.  
AUBURNDALE, FLORIDA

Client Reference No:  
CAE Project No: 8720-1

**RESULTS**

2-1

**Table 2-1:**  
**Unit 1 FF Outlet - Opacity - EPA Method 9**

Run No.	1	2	3	Average
Date (2000)	August 11	August 11	August 11	
Start Time (approx.)	09:40	13:05	17:50	
Stop Time (approx.)	10:40	14:05	18:50	
<b>Visible Emissions (%)</b>				
Average opacity (1 hour)	0	0	0	0
Maximum reading (15 second)	0	0	0	0
Maximum average (6 minute)	0	0	0	0
No. of readings >20% (15 second)	0	0	0	0



**RESULTS**

2-2

**Table 2-2:  
Unit 1 FF Outlet - Total Hydrocarbons - EPA Method 25A**

Run No.	1	2	4	Average
Date(2000)	August 11	August 11	August 11	
Start Time (approx.)	09:42	11:13	16:57	
Stop Time (approx.)	10:41	12:12	17:56	
<b>Process Conditions<sup>1</sup></b>				
Average generator output (megawatts)	46.9	46.3	44.9	46.0
Average steam flow (kpph)	364.4	360.9	351.1	358.8
Average stack flow (kscfm)	208	204	203	205
Average furnace temp. (°F)	2281	2255	2242	2259
Average opacity (%)	0.04	0.20	0.25	0.17
<b>Gas Conditions<sup>2</sup></b>				
T <sub>g</sub> Temperature (°F)	246	246	231	241
B <sub>g</sub> Moisture (volume %)	15.5	15.5	14.7	15.2
Q <sub>g</sub> Standard conditions (dscfm)	198,576	198,576	200,495	199,215
<b>Oxygen</b>				
C Concentration (%)	10.4	10.1	11.1	10.5
<b>Carbon Dioxide</b>				
C Concentration (%)	9.2	9.4	8.8	9.1
<b>Total Hydrocarbons as propane</b>				
C Concentration (ppmdv)	8.3	12.1	4.8	8.4
C Concentration (ppmwv)	7.0	10.2	4.1	7.1
C Concentration (ppm @ 7% O <sub>2</sub> )	11.0	15.6	6.8	11.1
C Concentration (ppm @ 12% CO <sub>2</sub> )	10.9	15.3	6.6	10.9
E Emission rate (lb/hr)	11.3	16.5	6.6	11.5
<b>Total Hydrocarbons as Carbon</b>				
C Concentration (ppmdv)	24.9	36.2	14.4	25.2
C Concentration (ppmwv)	21.0	30.6	12.3	21.3
C Concentration (ppm @ 7% O <sub>2</sub> )	32.9	46.8	20.4	33.4
C Concentration (ppm @ 12% CO <sub>2</sub> )	32.6	46.0	19.7	32.8
E Emission rate (lb/hr)	9.2	13.5	5.4	9.4

<sup>1</sup> Process Data was supplied by Wheelabrator Ridge Energy, Inc. personnel

<sup>2</sup> Gas conditions obtained from an average of concurrent Method 5/26A and Metals testing.



**RESULTS**

2-3

**Table 2-3:  
Unit 1 FF Outlet - Particulate, Hydrogen Chloride - EPA Method 26A**

Run No. <sup>1</sup>	1	3	4	Average
Date (2000)	August 11	August 11	August 11	
Start Time (approx.)	09:42	16:52	19:58	
Stop Time (approx.)	12:00	19:09	22:14	
<b>Process Conditions<sup>2</sup></b>				
Average generator output (megawatts)	46.6	45.6	45.7	46.0
Average steam flow (kpph)	361.7	355.6	354.3	357.2
Average stack flow (kscfm)	206	203	203	204
Average furnace temp. (°F)	2269	2249	2254	2257
Average opacity (%)	10.1	9.6	9.5	9.7
<b>Gas Conditions</b>				
O <sub>2</sub> Oxygen (dry volume %)	10.2	11.1	10.6	10.6
CO <sub>2</sub> Carbon dioxide (dry volume %)	8.7	8.2	9.0	8.6
T <sub>a</sub> Temperature (°F)	247	231	230	236.3
B <sub>w</sub> Moisture (volume %)	15.9	14.9	15.3	15.3
<b>Test Conditions</b>				
V <sub>rated</sub> Volume metered, standard (ft <sup>3</sup> )	79.56	78.49	76.98	78.3
% Isokinetic sampling (%)	96.8	95.0	96.5	96.0
<b>Volumetric Flow Rate</b>				
Q <sub>a</sub> Actual conditions (acfm)	347,700	332,300	325,000	335,000
Q <sub>std</sub> Standard conditions (dscfm)	203,400	204,100	197,000	201,500
<b>Particulate</b>				
m <sub>s</sub> Matter collected (g)	0.0121	0.0108	0.0163	0.0130
C Concentration (gr/acf)	0.0014	0.0013	0.0020	0.0015
C Concentration (gr/dscf)	0.0024	0.0021	0.0033	0.0026
C Corrected to 7% O <sub>2</sub> (gr/dscf)	0.0031	0.0030	0.0044	0.0035
C Corrected to 12% CO <sub>2</sub> (gr/dscf)	0.0033	0.0031	0.0043	0.0036
E Emission rate (lb/hr)	4.11	3.66	5.50	4.42
<b>Hydrogen Chloride</b>				
m Mass of HCl (mg)	0.77	0.40	0.27	0.48
C Concentration (ppmvd)	0.22	0.12	0.08	0.14
C Concentration, corrected to 7% O <sub>2</sub> (ppm)	0.29	0.17	0.11	0.19
C Concentration (mg/dscfm)	0.34	0.18	0.12	0.21
C Concentration, corrected to 7% O <sub>2</sub> (mg/dscfm)	0.44	0.26	0.17	0.29
E Emission rate (lb/hr)	0.26	0.14	0.09	0.16

<sup>1</sup> Run 2 was aborted and not reported due to process upset and an inability to run at > 90% of rated capacity.  
<sup>2</sup> Process Data was supplied by Wheelabrator Ridge Energy Inc. personnel



**RESULTS**

2-4

**Table 2-4:  
Unit 1 FF Outlet - Metals - EPA Method 29**

<b>Unit 1 FF Outlet</b>				
Run No.	1	3	4	Average
Date (2000)	August 11	August 11	August 11	
Start Time (approx.)	09:42	16:52	19:57	
Stop Time (approx.)	12:00	19:09	22:14	
<b>Process Conditions<sup>1</sup></b>				
Average generator output (megawatts)	46.6	45.6	45.7	46.3
Average steam flow (kpph)	361.7	355.6	354.3	359.7
Average stack flow (kschm)	206	203	203	205
Average furnace temp. (°F)	2269	2249	2254	2262
Average opacity (%)	0.11	0.32	0.31	0.18
<b>Gas Conditions</b>				
O <sub>2</sub> Oxygen (dry volume %)	10.2	11.1	10.8	10.6
CO <sub>2</sub> Carbon Dioxide (dry volume %)	8.7	8.2	9.0	8.6
T <sub>a</sub> Temperature (°F)	249	231	231	237
B <sub>w</sub> Moisture in sample (% by volume)	15.5	14.6	15.5	15.2
<b>Test Conditions</b>				
V <sub>met</sub> Volume metered, standard (ft <sup>3</sup> )	86.22	82.46	80.95	83.21
% Isokinetic sampling (%)	102.9	96.3	98.4	99.2
<b>Volumetric Flow Rate</b>				
Q <sub>a</sub> Actual conditions (acfm)	328,600	319,200	313,100	320,300
Q <sub>s</sub> Standard conditions (dscfm)	192,600	196,900	189,100	192,900
<b>Beryllium (Be)</b>				
m <sub>n</sub> Net weight (µg)	ND(0.100)	ND(0.100)	ND(0.100)	ND(0.100)
C Concentration (µg/dscm)	ND(0.041)	ND(0.043)	ND(0.044)	ND(0.042)
C Corrected to 7% O <sub>2</sub> (µg/dscm)	ND(0.053)	ND(0.061)	ND(0.059)	ND(0.058)
E Emission rate (lb/hr)	ND(2.95E-05)	ND(3.16E-05)	ND(3.09E-05)	ND(3.07E-05)
<b>Lead (Pb)</b>				
m <sub>n</sub> Net weight (µg)	2.66	3.86	4.66	3.73
C Concentration (µg/dscm)	1.09	1.65	2.03	1.59
C Corrected to 7% O <sub>2</sub> (µg/dscm)	1.42	2.34	2.74	2.17
E Emission rate (lb/hr)	0.0008	0.0012	0.0014	0.0011
<b>Mercury (Hg) Totals</b>				
m <sub>n</sub> Net weight (µg)	<0.799	ND(0.700)	<0.804	<0.768
C Concentration (µg/dscm)	<0.327	ND(0.300)	<0.351	<0.326
C Corrected to 7% O <sub>2</sub> (µg/dscm)	<0.425	ND(0.425)	<0.473	<0.441
E Emission rate (lb/hr)	<0.00024	ND(0.00022)	<0.00025	<0.00024

ND - Indicates the constituent was not detected. The detection limit is shown in parentheses.  
<sup>1</sup> All process conditions provided by Wheelabrator personnel.



WHEELABRATOR RIDGE ENERGY, INC.  
AUBURNDALE, FLORIDA

Client Reference No:  
CAE Project No: 8720-1

**RESULTS**

2-5

**Table 2-5:  
Lime Silo - Opacity - EPA Method 9**

<b>Run No.</b>	<b>1</b>
<b>Date (2000)</b>	<b>August 11</b>
<b>Start Time (approx.)</b>	<b>10:50</b>
<b>Stop Time (approx.)</b>	<b>11:20</b>
<b>Process Conditions<sup>1</sup></b>	
Filter Pressure Differential	9.0
Quantity of Lime Transferred (lbs)	51,060
Time to Transfer Lime (minutes)	106
Transfer Rate (lbs/hr)	28,367
Transfer Rate (tons/hr)	14.45
<b>Visible Emissions (%)</b>	
Average opacity (1 hour)	5
Maximum reading (15 second)	15
Maximum average (6 minute)	5
No. of readings >10% (15 second)	2

<sup>1</sup> Process conditions supplied by Wheelabrator personnel

Revision 0



**RESULTS**

2-6

**Table 2-6:  
Quality Control and Quality Assurance  
Metals and Hydrogen Chloride**

EPA Method 26A		Chlorides				
Sample ID:	Unit 1 Inlet Run 1	MS % Rec.	104.8			
<b>EPA Method 29</b>						
	<b>Method Blank Results (µg)</b>	<b>Reagent Blank Results (µg)</b>				
Hg Front half filter and probe rinse (1B)	ND(0.030)	ND(0.030)				
Hg (Impingers 1-3 Fraction 2B)	ND(0.010)	ND(0.39)				
Hg (Impinger 4 Fraction 3A)	ND(0.010)	ND(0.010)				
Hg (Impingers 5-6 Fraction 3B)	ND(0.050)	ND(0.050)				
Hg (HCl rinse of Impingers 5-6 Fraction 3C)	ND(0.050)	ND(0.050)				
Beryllium	ND(0.10)	ND(0.03)				
Lead	ND(0.20)	0.64				
<b>Sample ID: Unit 1 Outlet Run 1</b>						
<b>Fraction</b>	<b>Results (µg)</b>	<b>Duplicate (µg)</b>	<b>M. Spike (µg)</b>	<b>MS % Rec.</b>	<b>MS Dup. (µg)</b>	<b>MSD % Rec.</b>
Hg Front half filter and probe rinse (1B)	ND(0.030)	ND(0.030)	0.68	110	-	-
Hg (Impingers 1-3 Fraction 2B)	ND(0.600)	ND(0.600)	7.4	120	7.6	120
Hg (Impinger 4 Fraction 3A)	ND(0.010)	ND(0.010)	0.10	98	0.11	100
Hg (Impingers 5-6 Fraction 3B)	ND(0.050)	ND(0.050)	0.54	110	0.49	100
Hg (HCl rinse of Impingers 5-6 Fraction 3C)	0.099	0.098	0.37	54	0.37	54
Cadmium	ND(0.10)	ND(0.10)	140	92	140	92
Lead	3.3	3.2	170	110	160	110
<b>Sample ID: Blank Spike</b>						
<b>Fraction</b>	<b>BS #1 (µg)</b>	<b>BS % Rec. #1</b>	<b>BS #2 (µg)</b>	<b>BS % Rec. #2</b>		
Hg Front half filter and probe rinse (1B)	0.30	100	0.30	100		
Hg (Impingers 1-3 Fraction 2B)	0.10	100	0.093	93		
Hg (Impinger 4 Fraction 3A)	0.10	100	0.10	97		
Hg (Impingers 5-6 Fraction 3B)	0.53	110	0.50	100		
Hg (HCl rinse of Impingers 5-6 Fraction 3C)	0.50	100	0.50	100		
Cadmium	140	92	150	100		
Lead	140	96	150	100		

ND - Not detected. The detection limit is denoted in parentheses.  
MS % Rec. - Method Blank Percent Recovery  
BS % Rec. - Blank Spike Percent Recovery



**ATTACHMENT RGS-F1-C5**  
**Identification of Applicable Requirements**



**ATTACHMENT RGS-F1-C5  
FDEP Title V Core List**

[**Note:** The Title V Core List is meant to simplify the completion of the "List of Applicable Regulations" for DEP Form No. 62-210.900(1), Application for Air Permit - Long Form. The Title V Core List is a list of rules to which all Title V Sources are presumptively subject. The Title V Core List may be referenced in its entirety, or with specific exceptions. The Department may periodically update the Title V Core List.]

***Federal:*** ***(description)***

40 CFR 61, Subpart M: NESHAP for Asbestos.

40 CFR 82: Protection of Stratospheric Ozone.

40 CFR 82, Subpart B: Servicing of Motor Vehicle Air Conditioners (MVAC).

40 CFR 82, Subpart F: Recycling and Emissions Reduction.

***State:*** ***(description)***

**CHAPTER 62-4, F.A.C.: PERMITS, effective 06-01-01**

62-4.030, F.A.C.: General Prohibition.

62-4.040, F.A.C.: Exemptions.

62-4.050, F.A.C.: Procedure to Obtain Permits; Application.

62-4.060, F.A.C.: Consultation.

62-4.070, F.A.C.: Standards for Issuing or Denying Permits; Issuance; Denial.

62-4.080, F.A.C.: Modification of Permit Conditions.

62-4.090, F.A.C.: Renewals.

62-4.100, F.A.C.: Suspension and Revocation.

62-4.110, F.A.C.: Financial Responsibility.

62-4.120, F.A.C.: Transfer of Permits.

62-4.130, F.A.C.: Plant Operation - Problems.

62-4.150, F.A.C.: Review.

62-4.160, F.A.C.: Permit Conditions.

62-4.210, F.A.C.: Construction Permits.

62-4.220, F.A.C.: Operation Permit for New Sources.

**CHAPTER 62-210, F.A.C.: STATIONARY SOURCES - GENERAL  
REQUIREMENTS, effective 06-21-01**

62-210.300, F.A.C.: Permits Required.

62-210.300(1), F.A.C.: Air Construction Permits.

62-210.300(2), F.A.C.: Air Operation Permits.

62-210.300(3), F.A.C.: Exemptions.

62-210.300(5), F.A.C.: Notification of Startup.

62-210.300(6), F.A.C.: Emissions Unit Reclassification.

62-210.300(7), F.A.C.: Transfer of Air Permits.

62-210.350, F.A.C.: Public Notice and Comment.  
62-210.350(1), F.A.C.: Public Notice of Proposed Agency Action.  
62-210.350(2), F.A.C.: Additional Public Notice Requirements for Emissions Units Subject to Prevention of Significant Deterioration or Nonattainment-Area Preconstruction Review.  
62-210.350(3), F.A.C.: Additional Public Notice Requirements for Sources Subject to Operation Permits for Title V Sources.

62-210.360, F.A.C.: Administrative Permit Corrections.  
62-210.370(3), F.A.C.: Annual Operating Report for Air Pollutant Emitting Facility.  
62-210.400, F.A.C.: Emission Estimates.  
62-210.650, F.A.C.: Circumvention.  
62-210.700, F.A.C.: Excess Emissions.

62-210.900, F.A.C.: Forms and Instructions.  
62-210.900(1), F.A.C.: Application for Air Permit – Title V Source, Form and Instructions.  
62-210.900(5), F.A.C.: Annual Operating Report for Air Pollutant Emitting Facility, Form and Instructions.  
62-210.900(7), F.A.C.: Application for Transfer of Air Permit – Title V and Non-Title V Source.

**CHAPTER 62-212, F.A.C.: STATIONARY SOURCES - PRECONSTRUCTION REVIEW**, effective 08-17-00

**CHAPTER 62-213, F.A.C.: OPERATION PERMITS FOR MAJOR SOURCES OF AIR POLLUTION**, effective 04-16-01

62-213.205, F.A.C.: Annual Emissions Fee.  
62-213.400, F.A.C.: Permits and Permit Revisions Required.  
62-213.410, F.A.C.: Changes Without Permit Revision.  
62-213.412, F.A.C.: Immediate Implementation Pending Revision Process.  
62-213.415, F.A.C.: Trading of Emissions Within a Source.  
62-213.420, F.A.C.: Permit Applications.  
62-213.430, F.A.C.: Permit Issuance, Renewal, and Revision.  
62-213.440, F.A.C.: Permit Content.  
62-213.450, F.A.C.: Permit Review by EPA and Affected States  
62-213.460, F.A.C.: Permit Shield.

62-213.900, F.A.C.: Forms and Instructions.  
62-213.900(1), F.A.C.: Major Air Pollution Source Annual Emissions Fee Form.  
62-213.900(7), F.A.C.: Statement of Compliance Form.

**CHAPTER 62-296, F.A.C.: STATIONARY SOURCES - EMISSION STANDARDS,**  
effective 03-02-99

62-296.320(4)(c), F.A.C.: Unconfined Emissions of Particulate Matter.

62-296.320(2), F.A.C.: Objectionable Odor Prohibited.

**CHAPTER 62-297, F.A.C.: STATIONARY SOURCES - EMISSIONS MONITORING,**  
effective 03-02-99

62-297.310, F.A.C.: General Test Requirements.

62-297.330, F.A.C.: Applicable Test Procedures.

62-297.340, F.A.C.: Frequency of Compliance Tests.

62-297.345, F.A.C.: Stack Sampling Facilities Provided by the Owner of an Emissions Unit.

62-297.350, F.A.C.: Determination of Process Variables.

62-297.570, F.A.C.: Test Report.

62-297.620, F.A.C.: Exceptions and Approval of Alternate Procedures and Requirements.

**Miscellaneous:**

**CHAPTER 28-106, F.A.C.: Decisions Determining Substantial Interests**

**CHAPTER 62-110, F.A.C.: Exception to the Uniform Rules of Procedure, effective**  
07-01-98

**CHAPTER 62-256, F.A.C.: Open Burning and Frost Protection Fires, effective 11-30-94**

**CHAPTER 62-257, F.A.C.: Asbestos Notification and Fee, effective 02-09-99**

**CHAPTER 62-281, F.A.C.: Motor Vehicle Air Conditioning Refrigerant Recovery and**  
Recycling, effective 09-10-96

**ATTACHMENT RGS-F1-C6**  
**Identification of Insignificant Activities**

**ATTACHMENT RGS -F1-C6**  
**Identification of Insignificant Activities**

The following are unregulated and insignificant activities associated with the RGS facility. The insignificant activities identified in this application are provided for information only and are identified as examples of, but not limited to, the insignificant activities identified by the Division of Air Resource Management (DARM). It is understood that such activities do not have to be included with the Title V Application. The insignificant activities identified herein are consistent, in terms of amounts of emissions and types, with those activities listed in DARM's guidance.

Pursuant to Rule 62-210.300(3)(b)l., notice is herein provided that the emissions listed below are not subject to a permit issued by the Department of Environmental Protection and are exempt from permitting until a final determination is made under the Title V permitting requirements (Rule 62-213 F.A.C.). These units would not have triggered review under Rules 62-212.400 or 62-212.500 or any new source performance standard listed in Rule 62-204.800 F.A.C..

1. Propane Vaporizer
2. Wood Handling Operations
3. Tire Handling Operations
4. Diesel Fuel Oil Tank
5. Urea Tank
6. Reactor/Clarifier
7. Oil/Water Separators
8. Non-Oxidizing Biocide Storage Tank
9. Corrosion Inhibitor Storage Tank
10. Plant Roads
11. Ash Handling System
12. Fuel Building

**ATTACHMENT RGS-F1-C7**  
**Compliance Report and Plan**



# Department of Environmental Protection

## Division of Air Resource Management

### STATEMENT OF COMPLIANCE - TITLE V SOURCE

**REASON FOR SUBMISSION (Check one to indicate why this statement of compliance is being submitted)**

<input type="checkbox"/> Annual Requirement	<input type="checkbox"/> Transfer of Permit	<input type="checkbox"/> Permanent Facility Shutdown
---	---	--

REPORTING PERIOD*	REPORT DEADLINE**
January 1 through December 31 of (year) 2003	March 1, 2004

\*The statement of compliance must cover all conditions that were in effect during the indicated reporting period, including any conditions that were added, deleted, or changed through permit revision.

\*\*See Rule 62-213.440(3)(a)2., F.A.C.

Facility Owner/Company Name: Wheelabrator Ridge Energy Inc.

Site Name: Ridge Generating Station L.P. Facility ID No. 1050216 County: Polk

**COMPLIANCE STATEMENT (Check only one of the following three options)**

**A.** This facility was in compliance with all terms and conditions of the Title V Air Operation Permit and, if applicable, the Acid Rain Part, and there were no reportable incidents of deviations from applicable requirements associated with any malfunction or breakdown of process, fuel burning or emission control equipment, or monitoring systems during the reporting period identified above.

**B.** This facility was in compliance with all terms and conditions of the Title V Air Operation Permit and, if applicable, the Acid Rain Part; however, there were one or more reportable incidents of deviations from applicable requirements associated with malfunctions or breakdowns of process, fuel burning or emission control equipment, or monitoring systems during the reporting period identified above, which were reported to the Department. For each incident of deviation, the following information is included:

1. Date of report previously submitted identifying the incident of deviation.
2. Description of the incident.

**C.** This facility was in compliance with all terms and conditions of the Title V Air Operation Permit and, if applicable, the Acid Rain Part, EXCEPT those identified in the pages attached to this report and any reportable incidents of deviations from applicable requirements associated with malfunctions or breakdowns of process, fuel burning or emission control equipment, or monitoring systems during the reporting period identified above, which were reported to the Department. For each item of noncompliance, the following information is included:

1. Emissions unit identification number.
2. Specific permit condition number (note whether the permit condition has been added, deleted, or changed during certification period).
3. Description of the requirement of the permit condition.
4. Basis for the determination of noncompliance (for monitored parameters, indicate whether monitoring was continuous, i.e., recorded at least every 15 minutes, or intermittent).
5. Beginning and ending dates of periods of noncompliance.
6. Identification of the probable cause of noncompliance and description of corrective action or preventative measures implemented.
7. Dates of any reports previously submitted identifying this incident of noncompliance.

For each incident of deviation, as described in paragraph **B.** above, the following information is included:

1. Date of report previously submitted identifying the incident of deviation.
2. Description of the incident.

# STATEMENT OF COMPLIANCE - TITLE V SOURCE

## RESPONSIBLE OFFICIAL CERTIFICATION

I, the undersigned, am a responsible official (Title V air permit application or responsible official notification form on file with the Department) of the Title V source for which this document is being submitted. With respect to all matters other than Acid Rain program requirements, I hereby certify, based on the information and belief formed after reasonable inquiry, that the statements made and data contained in this document are true, accurate, and complete.

Phil Tuohy  
(Signature of Title V Source Responsible Official)

2/17/04  
(Date)

Name: Phil Tuohy

Title: Plant Manager

## DESIGNATED REPRESENTATIVE CERTIFICATION (only applicable to Acid Rain source)

I, the undersigned, am authorized to make this submission on behalf of the owners and operators of the Acid Rain source or Acid Rain units for which the submission is made. I certify under penalty of law that I have personally examined, and am familiar with, the statements and information submitted in this document and all its attachments. Based on my inquiry of those individuals with primary responsibility for obtaining the information, I certify that the statements and information are to the best of my knowledge and belief true, accurate, and complete. I am aware that there are significant penalties for submitting false statements and information or omitting required statements and information, including the possibility of fine or imprisonment.

\_\_\_\_\_  
(Signature of Acid Rain Source Designated Representative)

\_\_\_\_\_  
(Date)

Name: \_\_\_\_\_

Title: \_\_\_\_\_

*{Note: Attachments, if required, are created by a responsible official or designated representative, as appropriate, and should consist of the information specified and any supporting records. Additional information may also be attached by a responsible official or designated representative when elaboration is required for clarity. This report is to be submitted to both the compliance authority (DEP district or local air program) and the U.S. Environmental Protection Agency(EPA) (U.S. EPA Region 4, Air and EPCRA Enforcement Branch, 61 Forsyth Street, Atlanta GA 30303).}*



Ridge Generating Station L.P.  
 Facility ID No. 1050216  
 EU ID No. 001  
 Boiler

Title V Permit Condition	Finding	Planned Corrective Action	Closure Date
Section II, 17.d	2003 stack test report did not include the type and amount of fuel processed for each test run.	Calculations of the amount of fuel processed during each test run were made. The data was submitted to FDEP on 11/26/2003 as attachments to the 2003 stack test report.	11/25/2003
B.5	The 2003 VE of the lime silo (EU ID No. 003) did not include the pressure drop reading of the lime silo bag house.	Will include this requirement in future stack test protocols.	11/26/2003
A.7	The tire feed rate in pounds per hour was not continuously being recorded. Daily totalizer readings did not meet this requirement.	Hourly readings of tire feed rate in kpph has been added to the data daily report.	09/01/2003
A.8	CEM QA/QC plan revised in July 1999 is out of date. The plan still referenced Odessa data system and calculations. Other minor omissions and corrections need to be made.	The QA/QC Plan was revised on 08/18/2004.	08/18/2004
A.14	Quarterly reports including the 30-day rolling averages for CO, NOx, and SO2 were not submitted during the first and third quarter of 2002 and first quarter of 2003. The reports were submitted on an semi-annual basis instead.	The 30-day rolling averages were submitted to FDEP on 11/26/2003 as attachments to the previously submitted reports. Will begin to submit report on a quarterly basis.	11/25/2003

## EMISSIONS UNIT INFORMATION

Section [ 1 ] of [ 3 ]

### III. EMISSIONS UNIT INFORMATION

**Title V Air Operation Permit Application** - For Title V air operation permitting only, emissions units are classified as regulated, unregulated, or insignificant. If this is an application for Title V air operation permit, a separate Emissions Unit Information Section (including subsections A through I as required) must be completed for each regulated and unregulated emissions unit addressed in this application for air permit. Some of the subsections comprising the Emissions Unit Information Section of the form are optional for unregulated emissions units. Each such subsection is appropriately marked. Insignificant emissions units are required to be listed at Section II, Subsection C.

**Air Construction Permit or FESOP Application** - For air construction permitting or federally enforceable state air operation permitting, emissions units are classified as either subject to air permitting or exempt from air permitting. The concept of an "unregulated emissions unit" does not apply. If this is an application for air construction permit or FESOP, a separate Emissions Unit Information Section (including subsections A through I as required) must be completed for each emissions unit subject to air permitting addressed in this application for air permit. Emissions units exempt from air permitting are required to be listed at Section II, Subsection C.

**Air Construction Permit and Revised/Renewal Title V Air Operation Permit Application** - Where this application is used to apply for both an air construction permit and a revised/renewal Title V air operation permit, each emissions unit is classified as either subject to air permitting or exempt from air permitting for air construction permitting purposes and as regulated, unregulated, or insignificant for Title V air operation permitting purposes. **The air construction permitting classification must be used to complete the Emissions Unit Information Section of this application for air permit.** A separate Emissions Unit Information Section (including subsections A through I as required) must be completed for each emissions unit subject to air permitting addressed in this application for air permit. Emissions units exempt from air construction permitting and insignificant emissions units are required to be listed at Section II, Subsection C.

If submitting the application form in hard copy, the number of this Emissions Unit Information Section and the total number of Emissions Unit Information Sections submitted as part of this application must be indicated in the space provided at the top of each page.

**EMISSIONS UNIT INFORMATION**

Section [1] of [3]

**A. GENERAL EMISSIONS UNIT INFORMATION**

**Title V Air Operation Permit Emissions Unit Classification**

1. Regulated or Unregulated Emissions Unit? (Check one, if applying for an initial, revised or renewal Title V air operation permit. Skip this item if applying for an air construction permit or FESOP only.)

The emissions unit addressed in this Emissions Unit Information Section is a regulated emissions unit.

The emissions unit addressed in this Emissions Unit Information Section is an unregulated emissions unit.

**Emissions Unit Description and Status**

1. Type of Emissions Unit Addressed in this Section: (Check one)

This Emissions Unit Information Section addresses, as a single emissions unit, a single process or production unit, or activity, which produces one or more air pollutants and which has at least one definable emission point (stack or vent).

This Emissions Unit Information Section addresses, as a single emissions unit, a group of process or production units and activities which has at least one definable emission point (stack or vent) but may also produce fugitive emissions.

This Emissions Unit Information Section addresses, as a single emissions unit, one or more process or production units and activities which produce fugitive emissions only.

2. Description of Emissions Unit Addressed in this Section: **Solid fuel, traveling grate boiler burning wood waste, shredded tires, yard waste, propane, and landfill gas.**

3. Emissions Unit Identification Number: **001**

4. Emissions Unit Status Code: <b>A</b>	5. Commence Construction Date: <b>NA</b>	6. Initial Startup Date: <b>3/94</b>	7. Emissions Unit Major Group SIC Code: <b>49</b>	8. Acid Rain Unit? <input type="checkbox"/> Yes <input checked="" type="checkbox"/> No
--	---	---	--	--

9. Package Unit:  
Manufacturer: \_\_\_\_\_ Model Number: \_\_\_\_\_

10. Generator Nameplate Rating: **50 MW**

11. Emissions Unit Comment: **Title V Renewal and request to lower HCl emission limit to bring the total emissions of HAPs to less than the major source threshold See Attachment RGS-F1-C9.**

**EMISSIONS UNIT INFORMATION**

Section [1] of [3]

**Emissions Unit Control Equipment**

1. Control Equipment/Method(s) Description:

1. **Selective non-catalytic reduction (SNCR) system for control of oxides of nitrogen**
2. **Spray dryer absorber for control of acid gases and organic compounds**
3. **Fabric filter baghouse for control of particulate matter (including metals)**

2. Control Device or Method Code(s): **032, 067, 016**

**EMISSIONS UNIT INFORMATION**

Section [1 ] of [3 ]

**B. EMISSIONS UNIT CAPACITY INFORMATION**

(Optional for unregulated emissions units.)

**Emissions Unit Operating Capacity and Schedule**

1. Maximum Process or Throughput Rate: <b>115,596 lb/hr; 506,311 TPY Wood<sup>1</sup></b>
2. Maximum Production Rate: <b>NA</b>
3. Maximum Heat Input Rate: <b>630 million Btu/hr</b>
4. Maximum Incineration Rate: pounds/hr tons/day
5. Requested Maximum Operating Schedule: 24 hours/day 7 days/week 52 weeks/year 8,760 hours/year
6. Operating Capacity/Schedule Comment: <b><sup>1</sup>For informational purposes only, not permit limitations, estimated maximum process or throughput rates also include the following:</b> <ul style="list-style-type: none"><li>• Tires: 18,505 lb/hr (24-hr block avg.); 81,052 TPY</li><li>• Propane: 0.069 MMft<sup>3</sup>/hr; 213 MMft<sup>3</sup>/yr; based on federally enforceable limit of 10% heat input from propane; used for startup, shutdown, and combustion stabilization.</li><li>• Landfill gas: 0.18 MMft<sup>3</sup>/hr; 1,577 MMft<sup>3</sup>/yr</li></ul>

**EMISSIONS UNIT INFORMATION**

Section [ 1 ] of [ 3 ]

**C. EMISSION POINT (STACK/VENT) INFORMATION  
(Optional for unregulated emissions units.)****Emission Point Description and Type**

1. Identification of Point on Plot Plan or Flow Diagram: <b>ID No. 1</b>		2. Emission Point Type Code: <b>1</b>	
3. Descriptions of Emission Points Comprising this Emissions Unit for VE Tracking: <b>NA</b>			
4. ID Numbers or Descriptions of Emission Units with this Emission Point in Common: <b>NA</b>			
5. Discharge Type Code: <b>V</b>	6. Stack Height: feet <b>325</b>	7. Exit Diameter: feet <b>10</b>	
8. Exit Temperature: °F <b>276</b>	9. Actual Volumetric Flow Rate: acfm <b>302691</b>	10. Water Vapor: % <b>28.4</b>	
11. Maximum Dry Standard Flow Rate: dscfm <b>166579</b>		12. Nonstack Emission Point Height: feet <b>NA</b>	
13. Emission Point UTM Coordinates... Zone: East (km): North (km):		14. Emission Point Latitude/Longitude... Latitude (DD/MM/SS) Longitude (DD/MM/SS)	
15. Emission Point Comment:			

**EMISSIONS UNIT INFORMATION**

Section [ 1 ] of [ 3 ]

**D. SEGMENT (PROCESS/FUEL) INFORMATION****Segment Description and Rate:** Segment \_\_ of \_\_

1. Segment Description (Process/Fuel Type): <b>Wood waste combustion</b>		
2. Source Classification Code (SCC): <b>10100903</b>		3. SCC Units: <b>Tons burned</b>
4. Maximum Hourly Rate: <b>57.8</b>	5. Maximum Annual Rate: <b>506,311</b>	6. Estimated Annual Activity Factor: <b>NA</b>
7. Maximum % Sulfur: <b>NA</b>	8. Maximum % Ash: <b>NA</b>	9. Million Btu per SCC Unit: <b>10.9</b>
10. Segment Comment: <b>For informational purposes only, not permit limitations. All values are nominal based on fuel estimated Btu content of wood. Btu content of wood varies.</b>		

**Segment Description and Rate:** Segment \_\_ of \_\_

1. Segment Description (Process/Fuel Type): <b>Shredded tire combustion</b>		
2. Source Classification Code (SCC): <b>10101201</b>		3. SCC Units: <b>Tons Burned</b>
4. Maximum Hourly Rate: <b>9.25</b>	5. Maximum Annual Rate: <b>81,052</b>	6. Estimated Annual Activity Factor: <b>NA</b>
7. Maximum % Sulfur: <b>NA</b>	8. Maximum % Ash: <b>NA</b>	9. Million Btu per SCC Unit: <b>28</b>
10. Segment Comment:		

**EMISSIONS UNIT INFORMATION**

Section [ 1 ] of [ 3 ]

**D. SEGMENT (PROCESS/FUEL) INFORMATION (CONTINUED)****Segment Description and Rate:** Segment \_\_ of \_\_

1. Segment Description (Process/Fuel Type): <b>Propane combusted in boiler</b>		
2. Source Classification Code (SCC): <b>10101002</b>		3. SCC Units: <b>Million cubic feet burned</b>
4. Maximum Hourly Rate: <b>0.069</b>	5. Maximum Annual Rate: <b>213</b>	6. Estimated Annual Activity Factor:
7. Maximum % Sulfur:	8. Maximum % Ash:	9. Million Btu per SCC Unit: <b>2,592</b>
10. Segment Comment: <b>Based on permit limit of 10% heat input from propane, used for startup, shutdown, and combustion stabilization.</b>		

**Segment Description and Rate:** Segment \_\_ of \_\_

1. Segment Description (Process/Fuel Type): <b>Landfill gas combustion</b>		
2. Source Classification Code (SCC): <b>10101002</b>		3. SCC Units: <b>Million Cubic feet burned</b>
4. Maximum Hourly Rate: <b>0.18</b>	5. Maximum Annual Rate: <b>1,577</b>	6. Estimated Annual Activity Factor:
7. Maximum % Sulfur:	8. Maximum % Ash:	9. Million Btu per SCC Unit: <b>1,000</b>
10. Segment Comment:		



**EMISSIONS UNIT INFORMATION**

Section [ 1 ] of [ 3 ]

**E. EMISSIONS UNIT POLLUTANTS****List of Pollutants Emitted by Emissions Unit**

1. Pollutant Emitted	2. Primary Control Device Code	3. Secondary Control Device Code	4. Pollutant Regulatory Code
SO2	067	016	EL
VOC	067	016	EL
PM	016		EL
PM10	016		EL
NOx	032		EL
CO			EL
PB-Lead	016		EL
H106-HCl	067	016	EL
H021-Beryllium	016		EL
H114-Mercury	016	067	EL
SAM	067	016	NS
H015-Arsenic	016		NS
DIOX	067	016	NS
H017-Benzene	067	016	NS
H027-Cadmium	016		NS
H046-Chromium	016		NS
H150-PCB	067	016	NS

**F1. EMISSIONS UNIT POLLUTANT DETAIL INFORMATION –  
 POTENTIAL/ESTIMATED FUGITIVE EMISSIONS**

**(Optional for unregulated emissions units.)**

**Potential/Estimated Fugitive Emissions**

**Complete for each pollutant identified in Subsection E if applying for an air construction permit or concurrent processing of an air construction permit and a revised or renewal Title V permit. Complete for each emissions-limited pollutant identified in Subsection E if applying for an air operation permit.**

1. Pollutant Emitted: <b>SO2</b>	2. Total Percent Efficiency of Control:
3. Potential Emissions: <b>65.0 lb/hour</b> <b>284.7 tons/year</b>	4. Synthetically Limited? <input type="checkbox"/> Yes <input checked="" type="checkbox"/> No
5. Range of Estimated Fugitive Emissions (as applicable): to tons/year	
6. Emission Factor: <b>Permit Limit</b>  Reference: <b>Title V Permit 1050216-001-AV</b>	7. Emissions Method Code: <b>0</b>
8. Calculation of Emissions: <b>Permit Limit : Title V Permit 1050216-001-AV</b>	
9. Pollutant Potential/Estimated Fugitive Emissions Comment:	

**F2. EMISSIONS UNIT POLLUTANT DETAIL INFORMATION -  
 ALLOWABLE EMISSIONS**

Complete if the pollutant identified in Subsection F1 is or would be subject to a numerical emissions limitation.

**Allowable Emissions** Allowable Emissions 1 of 1

1. Basis for Allowable Emissions Code: <b>Other</b>	2. Future Effective Date of Allowable Emissions:
3. Allowable Emissions and Units: <b>65.0 lb/hr</b>	4. Equivalent Allowable Emissions: <b>65.0 lb/hour      284.7 tons/year</b>
5. Method of Compliance: <b>30-day rolling average CEM</b>	
6. Allowable Emissions Comment (Description of Operating Method): <b>Permit Limit : Title V Permit 1050216-001-AV</b>	

**Allowable Emissions** Allowable Emissions    of   

1. Basis for Allowable Emissions Code:	2. Future Effective Date of Allowable Emissions:
3. Allowable Emissions and Units:	4. Equivalent Allowable Emissions: lb/hour      tons/year
5. Method of Compliance:	
6. Allowable Emissions Comment (Description of Operating Method):	

**Allowable Emissions** Allowable Emissions    of   

1. Basis for Allowable Emissions Code:	2. Future Effective Date of Allowable Emissions:
3. Allowable Emissions and Units:	4. Equivalent Allowable Emissions: lb/hour      tons/year
5. Method of Compliance:	
6. Allowable Emissions Comment (Description of Operating Method):	

**F1. EMISSIONS UNIT POLLUTANT DETAIL INFORMATION –  
POTENTIAL/ESTIMATED FUGITIVE EMISSIONS**

(Optional for unregulated emissions units.)

**Potential/Estimated Fugitive Emissions**

Complete for each pollutant identified in Subsection E if applying for an air construction permit or concurrent processing of an air construction permit and a revised or renewal Title V permit. Complete for each emissions-limited pollutant identified in Subsection E if applying for an air operation permit.

1. Pollutant Emitted: <b>VOC</b>	2. Total Percent Efficiency of Control:
3. Potential Emissions: <b>22.1 lb/hour</b> <b>96.8 tons/year</b>	4. Synthetically Limited? <input type="checkbox"/> Yes <input checked="" type="checkbox"/> No
5. Range of Estimated Fugitive Emissions (as applicable): to tons/year	
6. Emission Factor: <b>Permit Limit</b>  Reference: <b>Title V Permit 1050216-001-AV</b>	7. Emissions Method Code: <b>0</b>
8. Calculation of Emissions: <b>Permit Limit : Title V Permit 1050216-001-AV</b>	
9. Pollutant Potential/Estimated Fugitive Emissions Comment:	

**F2. EMISSIONS UNIT POLLUTANT DETAIL INFORMATION -  
 ALLOWABLE EMISSIONS**

**Complete if the pollutant identified in Subsection F1 is or would be subject to a numerical emissions limitation.**

**Allowable Emissions** Allowable Emissions 1 of 1

1. Basis for Allowable Emissions Code: <b>Other</b>	2. Future Effective Date of Allowable Emissions:
3. Allowable Emissions and Units: <b>22.1 lb/hr</b>	4. Equivalent Allowable Emissions: <b>22.1 lb/hour      96.8 tons/year</b>
5. Method of Compliance: <b>Annual stack test; EPA Method 25A (if test required)</b>	
6. Allowable Emissions Comment (Description of Operating Method): <b>Permit Limit : Title V Permit 1050216-001-AV</b>	

**Allowable Emissions** Allowable Emissions    of   

1. Basis for Allowable Emissions Code:	2. Future Effective Date of Allowable Emissions:
3. Allowable Emissions and Units:	4. Equivalent Allowable Emissions: lb/hour      tons/year
5. Method of Compliance:	
6. Allowable Emissions Comment (Description of Operating Method):	

**Allowable Emissions** Allowable Emissions    of   

1. Basis for Allowable Emissions Code:	2. Future Effective Date of Allowable Emissions:
3. Allowable Emissions and Units:	4. Equivalent Allowable Emissions: lb/hour      tons/year
5. Method of Compliance:	
6. Allowable Emissions Comment (Description of Operating Method):	

**F1. EMISSIONS UNIT POLLUTANT DETAIL INFORMATION –  
POTENTIAL/ESTIMATED FUGITIVE EMISSIONS**

(Optional for unregulated emissions units.)

**Potential/Estimated Fugitive Emissions**

Complete for each pollutant identified in Subsection E if applying for an air construction permit or concurrent processing of an air construction permit and a revised or renewal Title V permit. Complete for each emissions-limited pollutant identified in Subsection E if applying for an air operation permit.

1. Pollutant Emitted: <b>PM</b>	2. Total Percent Efficiency of Control:	
3. Potential Emissions: <b>12.6 lb/hour</b> <b>55.2 tons/year</b>		4. Synthetically Limited? <input type="checkbox"/> Yes <input checked="" type="checkbox"/> No
5. Range of Estimated Fugitive Emissions (as applicable): to tons/year		
6. Emission Factor: <b>0.0080 gr/SCF (corrected to 7% Oxygen)</b>  Reference: <b>Title V Permit 1050216-001-AV</b>		7. Emissions Method Code: <b>0</b>
8. Calculation of Emissions: <b>lb/hr and tons/year are "equivalent emissions" listed for informational purposes only, not permit limitations. Emission factor = Permit Limit : Title V Permit 1050216-001-AV</b>		
9. Pollutant Potential/Estimated Fugitive Emissions Comment:		

**F2. EMISSIONS UNIT POLLUTANT DETAIL INFORMATION -  
 ALLOWABLE EMISSIONS**

**Complete if the pollutant identified in Subsection F1 is or would be subject to a numerical emissions limitation.**

**Allowable Emissions** Allowable Emissions 1 of 1

1. Basis for Allowable Emissions Code: <b>Other</b>	2. Future Effective Date of Allowable Emissions:
3. Allowable Emissions and Units: <b>0.0080 gr/SCF @ 7% Oxygen</b>	4. Equivalent Allowable Emissions: <b>12.6 lb/hour      55.2 tons/year</b>
5. Method of Compliance: <b>Annual stack test; EPA Method 5 (if test required)</b>	
6. Allowable Emissions Comment (Description of Operating Method): <b>Permit Limit : Title V Permit 1050216-001-AV</b>	

**Allowable Emissions** Allowable Emissions    of   

1. Basis for Allowable Emissions Code:	2. Future Effective Date of Allowable Emissions:
3. Allowable Emissions and Units:	4. Equivalent Allowable Emissions: lb/hour      tons/year
5. Method of Compliance:	
6. Allowable Emissions Comment (Description of Operating Method):	

**Allowable Emissions** Allowable Emissions    of   

1. Basis for Allowable Emissions Code:	2. Future Effective Date of Allowable Emissions:
3. Allowable Emissions and Units:	4. Equivalent Allowable Emissions: lb/hour      tons/year
5. Method of Compliance:	
6. Allowable Emissions Comment (Description of Operating Method):	

**F1. EMISSIONS UNIT POLLUTANT DETAIL INFORMATION –  
 POTENTIAL/ESTIMATED FUGITIVE EMISSIONS**

(Optional for unregulated emissions units.)

**Potential/Estimated Fugitive Emissions**

Complete for each pollutant identified in Subsection E if applying for an air construction permit or concurrent processing of an air construction permit and a revised or renewal Title V permit. Complete for each emissions-limited pollutant identified in Subsection E if applying for an air operation permit.

1. Pollutant Emitted: <b>PM10</b>		2. Total Percent Efficiency of Control:	
3. Potential Emissions: <b>12.6 lb/hour</b> <b>55.2 tons/year</b>		4. Synthetically Limited? <input type="checkbox"/> Yes <input checked="" type="checkbox"/> No	
5. Range of Estimated Fugitive Emissions (as applicable): to   tons/year			
6. Emission Factor: <b>0.0080 gr/SCF (corrected to 7% Oxygen)</b>  Reference: <b>Title V Permit 1050216-001-AV</b>		7. Emissions Method Code: <b>0</b>	
8. Calculation of Emissions: <b>lb/hr and tons/year are "equivalent emissions" listed for informational purposes only,              not permit limitations. Emission factor = Permit Limit : Title V Permit 1050216-001-AV</b>			
9. Pollutant Potential/Estimated Fugitive Emissions Comment:			



**F2. EMISSIONS UNIT POLLUTANT DETAIL INFORMATION -  
 ALLOWABLE EMISSIONS**

Complete if the pollutant identified in Subsection F1 is or would be subject to a numerical emissions limitation.

Allowable Emissions Allowable Emissions 1 of 1

1. Basis for Allowable Emissions Code: <b>Other</b>	2. Future Effective Date of Allowable Emissions:
3. Allowable Emissions and Units: <b>0.0080 gr/SCF @ 7% Oxygen</b>	4. Equivalent Allowable Emissions: <b>12.6 lb/hour      55.2 tons/year</b>
5. Method of Compliance: <b>Annual stack test; EPA Method 5 (if test required)</b>	
6. Allowable Emissions Comment (Description of Operating Method): <b>Permit Limit : Title V Permit 1050216-001-AV</b>	

Allowable Emissions Allowable Emissions    of   

1. Basis for Allowable Emissions Code:	2. Future Effective Date of Allowable Emissions:
3. Allowable Emissions and Units:	4. Equivalent Allowable Emissions: lb/hour      tons/year
5. Method of Compliance:	
6. Allowable Emissions Comment (Description of Operating Method):	

Allowable Emissions Allowable Emissions    of   

1. Basis for Allowable Emissions Code:	2. Future Effective Date of Allowable Emissions:
3. Allowable Emissions and Units:	4. Equivalent Allowable Emissions: lb/hour      tons/year
5. Method of Compliance:	
6. Allowable Emissions Comment (Description of Operating Method):	

**F1. EMISSIONS UNIT POLLUTANT DETAIL INFORMATION –  
 POTENTIAL/ESTIMATED FUGITIVE EMISSIONS**

**(Optional for unregulated emissions units.)**

**Potential/Estimated Fugitive Emissions**

**Complete for each pollutant identified in Subsection E if applying for an air construction permit or concurrent processing of an air construction permit and a revised or renewal Title V permit. Complete for each emissions-limited pollutant identified in Subsection E if applying for an air operation permit.**

1. Pollutant Emitted: <b>NOx</b>	2. Total Percent Efficiency of Control:
3. Potential Emissions: <b>90.0 lb/hour</b> <b>394.2 tons/year</b>	4. Synthetically Limited? <input type="checkbox"/> Yes <input checked="" type="checkbox"/> No
5. Range of Estimated Fugitive Emissions (as applicable): to   tons/year	
6. Emission Factor: <b>Permit Limit</b>  Reference: <b>Title V Permit 1050216-001-AV</b>	7. Emissions Method Code: <b>0</b>
8. Calculation of Emissions: <b>Permit Limit : Title V Permit 1050216-001-AV</b>	
9. Pollutant Potential/Estimated Fugitive Emissions Comment:	

**F2. EMISSIONS UNIT POLLUTANT DETAIL INFORMATION -  
 ALLOWABLE EMISSIONS**

Complete if the pollutant identified in Subsection F1 is or would be subject to a numerical emissions limitation.

**Allowable Emissions** Allowable Emissions 1 of 1

1. Basis for Allowable Emissions Code: <b>Other</b>	2. Future Effective Date of Allowable Emissions:
3. Allowable Emissions and Units: <b>90.0 lb/hr</b>	4. Equivalent Allowable Emissions: <b>90.0 lb/hour      394.2 tons/year</b>
5. Method of Compliance: <b>30-day rolling average CEM</b>	
6. Allowable Emissions Comment (Description of Operating Method): <b>Permit Limit : Title V Permit 1050216-001-AV</b>	

**Allowable Emissions** Allowable Emissions    of   

1. Basis for Allowable Emissions Code:	2. Future Effective Date of Allowable Emissions:
3. Allowable Emissions and Units:	4. Equivalent Allowable Emissions: lb/hour      tons/year
5. Method of Compliance:	
6. Allowable Emissions Comment (Description of Operating Method):	

**Allowable Emissions** Allowable Emissions    of   

1. Basis for Allowable Emissions Code:	2. Future Effective Date of Allowable Emissions:
3. Allowable Emissions and Units:	4. Equivalent Allowable Emissions: lb/hour      tons/year
5. Method of Compliance:	
6. Allowable Emissions Comment (Description of Operating Method):	

**F1. EMISSIONS UNIT POLLUTANT DETAIL INFORMATION –  
POTENTIAL/ESTIMATED FUGITIVE EMISSIONS**

**(Optional for unregulated emissions units.)**

**Potential/Estimated Fugitive Emissions**

**Complete for each pollutant identified in Subsection E if applying for an air construction permit or concurrent processing of an air construction permit and a revised or renewal Title V permit. Complete for each emissions-limited pollutant identified in Subsection E if applying for an air operation permit.**

1. Pollutant Emitted: <b>CO</b>		2. Total Percent Efficiency of Control:	
3. Potential Emissions: <b>200.0 lb/hour                      876.0 tons/year</b>		4. Synthetically Limited? <input type="checkbox"/> Yes <input checked="" type="checkbox"/> No	
5. Range of Estimated Fugitive Emissions (as applicable): to tons/year			
6. Emission Factor: <b>Permit Limit</b>  Reference: <b>Title V Permit 1050216-001-AV</b>		7. Emissions Method Code: <b>0</b>	
8. Calculation of Emissions: <b>Permit Limit : Title V Permit 1050216-001-AV</b>			
9. Pollutant Potential/Estimated Fugitive Emissions Comment:			

**F2. EMISSIONS UNIT POLLUTANT DETAIL INFORMATION -  
 ALLOWABLE EMISSIONS**

**Complete if the pollutant identified in Subsection F1 is or would be subject to a numerical emissions limitation.**

**Allowable Emissions** Allowable Emissions 1 of 1

1. Basis for Allowable Emissions Code: <b>Other</b>	2. Future Effective Date of Allowable Emissions:
3. Allowable Emissions and Units: <b>200.0 lb/hr</b>	4. Equivalent Allowable Emissions: <b>200.0 lb/hour      876.0 tons/year</b>
5. Method of Compliance: <b>30-day rolling average CEM</b>	
6. Allowable Emissions Comment (Description of Operating Method): <b>Permit Limit : Title V Permit 1050216-001-AV</b>	

**Allowable Emissions** Allowable Emissions    of   

1. Basis for Allowable Emissions Code:	2. Future Effective Date of Allowable Emissions:
3. Allowable Emissions and Units:	4. Equivalent Allowable Emissions: lb/hour      tons/year
5. Method of Compliance:	
6. Allowable Emissions Comment (Description of Operating Method):	

**Allowable Emissions** Allowable Emissions    of   

1. Basis for Allowable Emissions Code:	2. Future Effective Date of Allowable Emissions:
3. Allowable Emissions and Units:	4. Equivalent Allowable Emissions: lb/hour      tons/year
5. Method of Compliance:	
6. Allowable Emissions Comment (Description of Operating Method):	

**F1. EMISSIONS UNIT POLLUTANT DETAIL INFORMATION –  
 POTENTIAL/ESTIMATED FUGITIVE EMISSIONS**

(Optional for unregulated emissions units.)

**Potential/Estimated Fugitive Emissions**

Complete for each pollutant identified in Subsection E if applying for an air construction permit or concurrent processing of an air construction permit and a revised or renewal Title V permit. Complete for each emissions-limited pollutant identified in Subsection E if applying for an air operation permit.

1. Pollutant Emitted: <b>PB - Lead</b>	2. Total Percent Efficiency of Control:
3. Potential Emissions: 0.25 lb/hour                      1.1 tons/year	4. Synthetically Limited? <input type="checkbox"/> Yes <input checked="" type="checkbox"/> No
5. Range of Estimated Fugitive Emissions (as applicable): to tons/year	
6. Emission Factor: <b>Permit Limit</b>  Reference: <b>Title V Permit 1050216-001-AV</b>	7. Emissions Method Code: <b>0</b>
8. Calculation of Emissions: <b>Permit Limit : Title V Permit 1050216-001-AV</b>	
9. Pollutant Potential/Estimated Fugitive Emissions Comment:	

**F2. EMISSIONS UNIT POLLUTANT DETAIL INFORMATION -  
 ALLOWABLE EMISSIONS**

Complete if the pollutant identified in Subsection F1 is or would be subject to a numerical emissions limitation.

**Allowable Emissions** Allowable Emissions 1 of 1

1. Basis for Allowable Emissions Code: <b>Other</b>	2. Future Effective Date of Allowable Emissions:
3. Allowable Emissions and Units: <b>0.25 lb/hr</b>	4. Equivalent Allowable Emissions: <b>0.25 lb/hour      1.1 tons/year</b>
5. Method of Compliance: <b>Annual stack test; EPA Methods 12, 29 (if test required)</b>	
6. Allowable Emissions Comment (Description of Operating Method): <b>Permit Limit : Title V Permit 1050216-001-AV</b>	

**Allowable Emissions** Allowable Emissions    of   

1. Basis for Allowable Emissions Code:	2. Future Effective Date of Allowable Emissions:
3. Allowable Emissions and Units:	4. Equivalent Allowable Emissions: lb/hour      tons/year
5. Method of Compliance:	
6. Allowable Emissions Comment (Description of Operating Method):	

**Allowable Emissions** Allowable Emissions    of   

1. Basis for Allowable Emissions Code:	2. Future Effective Date of Allowable Emissions:
3. Allowable Emissions and Units:	4. Equivalent Allowable Emissions: lb/hour      tons/year
5. Method of Compliance:	
6. Allowable Emissions Comment (Description of Operating Method):	

F1. EMISSIONS UNIT POLLUTANT DETAIL INFORMATION –  
 POTENTIAL/ESTIMATED FUGITIVE EMISSIONS

(Optional for unregulated emissions units.)

Potential/Estimated Fugitive Emissions

Complete for each pollutant identified in Subsection E if applying for an air construction permit or concurrent processing of an air construction permit and a revised or renewal Title V permit. Complete for each emissions-limited pollutant identified in Subsection E if applying for an air operation permit.

1. Pollutant Emitted: <b>H106 - HCl</b>	2. Total Percent Efficiency of Control:
3. Potential Emissions: <b>2.1 lb/hour</b> <b>9.2 tons/year</b>	4. Synthetically Limited? <input type="checkbox"/> Yes <input checked="" type="checkbox"/> No
5. Range of Estimated Fugitive Emissions (as applicable): to tons/year	
6. Emission Factor: <b>2.1 lb/hr</b>  Reference: <b>Based on compliance test results for 2001 - 2003</b>	7. Emissions Method Code:
8. Calculation of Emissions:  <b>Request lower HCl emission limit to bring the total emissions of HAPs to less than the major source threshold. See Attachment RGS – F1 – C7</b>	
9. Pollutant Potential/Estimated Fugitive Emissions Comment:	



**F2. EMISSIONS UNIT POLLUTANT DETAIL INFORMATION -  
ALLOWABLE EMISSIONS**

**Complete if the pollutant identified in Subsection F1 is or would be subject to a numerical emissions limitation.**

**Allowable Emissions** Allowable Emissions 1 of 1

1. Basis for Allowable Emissions Code: <b>Other</b>	2. Future Effective Date of Allowable Emissions:
3. Allowable Emissions and Units: <b>2.1 lb/hr</b>	4. Equivalent Allowable Emissions: <b>2.1 lb/hour      9.2 tons/year</b>
5. Method of Compliance: <b>Annual stack test; EPA Method 26, 26A (if test required)</b>	
6. Allowable Emissions Comment (Description of Operating Method): <b>Request lower HCl emission limit to bring the total emissions of HAPs to less than the major source threshold. See Attachment RGS-F1-C4.</b>	

**Allowable Emissions** Allowable Emissions    of   

1. Basis for Allowable Emissions Code:	2. Future Effective Date of Allowable Emissions:
3. Allowable Emissions and Units:	4. Equivalent Allowable Emissions: lb/hour      tons/year
5. Method of Compliance:	
6. Allowable Emissions Comment (Description of Operating Method):	

**Allowable Emissions** Allowable Emissions    of   

1. Basis for Allowable Emissions Code:	2. Future Effective Date of Allowable Emissions:
3. Allowable Emissions and Units:	4. Equivalent Allowable Emissions: lb/hour      tons/year
5. Method of Compliance:	
6. Allowable Emissions Comment (Description of Operating Method):	

**F1. EMISSIONS UNIT POLLUTANT DETAIL INFORMATION –  
POTENTIAL/ESTIMATED FUGITIVE EMISSIONS**

(Optional for unregulated emissions units.)

**Potential/Estimated Fugitive Emissions**

Complete for each pollutant identified in Subsection E if applying for an air construction permit or concurrent processing of an air construction permit and a revised or renewal Title V permit. Complete for each emissions-limited pollutant identified in Subsection E if applying for an air operation permit.

1. Pollutant Emitted: <b>H021-Beryllium</b>	2. Total Percent Efficiency of Control:
3. Potential Emissions: <b>0.0063 lb/hour                      0.028 tons/year</b>	4. Synthetically Limited? <input type="checkbox"/> Yes <input checked="" type="checkbox"/> No
5. Range of Estimated Fugitive Emissions (as applicable): to tons/year	
6. Emission Factor: <b>Permit Limit</b>  Reference: <b>Title V Permit 1050216-001-AV</b>	7. Emissions Method Code: <b>0</b>
8. Calculation of Emissions: <b>Permit Limit : Title V Permit 1050216-001-AV</b>	
9. Pollutant Potential/Estimated Fugitive Emissions Comment:	

**F2. EMISSIONS UNIT POLLUTANT DETAIL INFORMATION -  
 ALLOWABLE EMISSIONS**

Complete if the pollutant identified in Subsection F1 is or would be subject to a numerical emissions limitation.

**Allowable Emissions** Allowable Emissions 1 of 1

1. Basis for Allowable Emissions Code: <b>Other</b>	2. Future Effective Date of Allowable Emissions:
3. Allowable Emissions and Units: <b>0.0063 lb/hr</b>	4. Equivalent Allowable Emissions: <b>0.0063 lb/hour      0.028 tons/year</b>
5. Method of Compliance: <b>Annual stack test; EPA Method 29, 104 (if test required)</b>	
6. Allowable Emissions Comment (Description of Operating Method): <b>Permit Limit : Title V Permit 1050216-001-AV</b>	

**Allowable Emissions** Allowable Emissions    of   

1. Basis for Allowable Emissions Code:	2. Future Effective Date of Allowable Emissions:
3. Allowable Emissions and Units:	4. Equivalent Allowable Emissions: lb/hour                      tons/year
5. Method of Compliance:	
6. Allowable Emissions Comment (Description of Operating Method):	

**Allowable Emissions** Allowable Emissions    of   

1. Basis for Allowable Emissions Code:	2. Future Effective Date of Allowable Emissions:
3. Allowable Emissions and Units:	4. Equivalent Allowable Emissions: lb/hour                      tons/year
5. Method of Compliance:	
6. Allowable Emissions Comment (Description of Operating Method):	

**F1. EMISSIONS UNIT POLLUTANT DETAIL INFORMATION –  
 POTENTIAL/ESTIMATED FUGITIVE EMISSIONS**

(Optional for unregulated emissions units.)

**Potential/Estimated Fugitive Emissions**

Complete for each pollutant identified in Subsection E if applying for an air construction permit or concurrent processing of an air construction permit and a revised or renewal Title V permit. Complete for each emissions-limited pollutant identified in Subsection E if applying for an air operation permit.

1. Pollutant Emitted: <b>H114-Mercury</b>	2. Total Percent Efficiency of Control:
3. Potential Emissions: 0.022 lb/hour                      0.096 tons/year	4. Synthetically Limited? <input type="checkbox"/> Yes <input checked="" type="checkbox"/> No
5. Range of Estimated Fugitive Emissions (as applicable): to tons/year	
6. Emission Factor: <b>Permit Limit</b>  Reference: <b>Title V Permit 1050216-001-AV</b>	7. Emissions Method Code: <b>0</b>
8. Calculation of Emissions: <b>Permit Limit : Title V Permit 1050216-001-AV</b>	
9. Pollutant Potential/Estimated Fugitive Emissions Comment:	

**F2. EMISSIONS UNIT POLLUTANT DETAIL INFORMATION -  
 ALLOWABLE EMISSIONS**

**Complete if the pollutant identified in Subsection F1 is or would be subject to a numerical emissions limitation.**

**Allowable Emissions** Allowable Emissions  1  of  1

1. Basis for Allowable Emissions Code: <b>Other</b>	2. Future Effective Date of Allowable Emissions:
3. Allowable Emissions and Units: <b>0.022 lb/hr</b>	4. Equivalent Allowable Emissions: <b>0.022 lb/hour      0.096 tons/year</b>
5. Method of Compliance: <b>Annual stack test; EPA Method 29, 101A (if test required)</b>	
6. Allowable Emissions Comment (Description of Operating Method): <b>Permit Limit : Title V Permit 1050216-001-AV</b>	

**Allowable Emissions** Allowable Emissions      of    

1. Basis for Allowable Emissions Code:	2. Future Effective Date of Allowable Emissions:
3. Allowable Emissions and Units:	4. Equivalent Allowable Emissions: lb/hour                      tons/year
5. Method of Compliance:	
6. Allowable Emissions Comment (Description of Operating Method):	

**Allowable Emissions** Allowable Emissions      of    

1. Basis for Allowable Emissions Code:	2. Future Effective Date of Allowable Emissions:
3. Allowable Emissions and Units:	4. Equivalent Allowable Emissions: lb/hour                      tons/year
5. Method of Compliance:	
6. Allowable Emissions Comment (Description of Operating Method):	

**EMISSIONS UNIT INFORMATION**

Section [ 1 ] of [ 3 ]

**G. VISIBLE EMISSIONS INFORMATION**

**Complete if this emissions unit is or would be subject to a unit-specific visible emissions limitation.**

**Visible Emissions Limitation:** Visible Emissions Limitation 1 of 1

1. Visible Emissions Subtype: <b>VE10</b>	2. Basis for Allowable Opacity: <input type="checkbox"/> Rule <input checked="" type="checkbox"/> Other
3. Allowable Opacity: Normal Conditions: <b>10 %</b> Exceptional Conditions: % Maximum Period of Excess Opacity Allowed: min/hour	
4. Method of Compliance: <b>EPA Method 9, Annual Test</b>	
5. Visible Emissions Comment: <b>Permit limit; Title V Permit 1050216-001-AV</b>	

**Visible Emissions Limitation:** Visible Emissions Limitation \_\_\_ of \_\_\_

1. Visible Emissions Subtype:	2. Basis for Allowable Opacity: <input type="checkbox"/> Rule <input type="checkbox"/> Other
3. Allowable Opacity: Normal Conditions: % Exceptional Conditions: % Maximum Period of Excess Opacity Allowed: min/hour	
4. Method of Compliance:	
5. Visible Emissions Comment:	

**EMISSIONS UNIT INFORMATION**

Section [ 1 ] of [ 3 ]

**H. CONTINUOUS MONITOR INFORMATION**

**Complete if this emissions unit is or would be subject to continuous monitoring.**

**Continuous Monitoring System:** Continuous Monitor  1  of  4

1. Parameter Code: <b>EM</b>	2. Pollutant(s): <b>SO2</b>
3. CMS Requirement: <input type="checkbox"/> Rule <input checked="" type="checkbox"/> Other	
4. Monitor Information... Manufacturer: <b>Perkin Elmer MCS 100</b> Model Number: <b>721AT</b> Serial Number:	
5. Installation Date: <b>04/92</b>	6. Performance Specification Test Date: <b>09/94</b>
7. Continuous Monitor Comment:	

**Continuous Monitoring System:** Continuous Monitor  2  of  4

1. Parameter Code: <b>EM</b>	2. Pollutant(s): <b>NOx</b>
3. CMS Requirement: <input type="checkbox"/> Rule <input checked="" type="checkbox"/> Other	
4. Monitor Information... Manufacturer: <b>Perkin Elmer MCS 100 - Beckman</b> Model Number: <b>951A</b> Serial Number:	
5. Installation Date: <b>04/92</b>	6. Performance Specification Test Date: <b>09/94</b>
7. Continuous Monitor Comment:	

**EMISSIONS UNIT INFORMATION**

Section [ ] of [ ]

**H. CONTINUOUS MONITOR INFORMATION (CONTINUED)**

**Complete if this emissions unit is or would be subject to continuous monitoring.**

**Continuous Monitoring System:** Continuous Monitor 3 of 4

1. Parameter Code: <b>EM</b>	2. Pollutant(s): <b>CO</b>
3. CMS Requirement: <input type="checkbox"/> Rule <input checked="" type="checkbox"/> Other	
4. Monitor Information... Manufacturer: <b>Perkin Elmer MCS 100 - TEI</b> Model Number: <b>48</b> Serial Number:	
5. Installation Date: <b>04/92</b>	6. Performance Specification Test Date: <b>09/94</b>
7. Continuous Monitor Comment:	

**Continuous Monitoring System:** Continuous Monitor 4 of 4

1. Parameter Code: <b>VE</b>	2. Pollutant(s): <b>VE</b>
3. CMS Requirement: <input checked="" type="checkbox"/> Rule <input type="checkbox"/> Other	
4. Monitor Information... Manufacturer: <b>Thermo Environmental Instruments</b> Model Number: <b>400B</b> Serial Number:	
5. Installation Date: <b>04/92</b>	6. Performance Specification Test Date: <b>09/94</b>
7. Continuous Monitor Comment: <b>40 CFR Part 60, Subpart Db</b>	



7. Other Information Required by Rule or Statute

Attached, Document ID: \_\_\_\_\_

Not Applicable

## EMISSIONS UNIT INFORMATION

Section [ ] of [ ]

### Additional Requirements for Air Construction Permit Applications

1. Control Technology Review and Analysis (Rules 62-212.400(6) and 62-212.500(7), F.A.C.; 40 CFR 63.43(d) and (e)) <input type="checkbox"/> Attached, Document ID: _____ <input checked="" type="checkbox"/> Not Applicable
2. Good Engineering Practice Stack Height Analysis (Rule 62-212.400(5)(h)6., F.A.C., and Rule 62-212.500(4)(f), F.A.C.) <input type="checkbox"/> Attached, Document ID: _____ <input checked="" type="checkbox"/> Not Applicable
3. Description of Stack Sampling Facilities (Required for proposed new stack sampling facilities only) <input type="checkbox"/> Attached, Document ID: _____ <input checked="" type="checkbox"/> Not Applicable

### Additional Requirements for Title V Air Operation Permit Applications

1. Identification of Applicable Requirements <input checked="" type="checkbox"/> Attached, Document ID: <b><u>RGS-EU1-I6</u></b>
2. Compliance Assurance Monitoring <input checked="" type="checkbox"/> Attached, Document ID: <b><u>RGS-EU1-I7</u></b> <input type="checkbox"/> Not Applicable
3. Alternative Methods of Operation <input checked="" type="checkbox"/> Attached, Document ID: <b><u>RGS-EU1-I8</u></b> <input type="checkbox"/> Not Applicable
4. Alternative Modes of Operation (Emissions Trading) <input type="checkbox"/> Attached, Document ID: _____ <input checked="" type="checkbox"/> Not Applicable

5. Acid Rain Part Application

- Certificate of Representation (EPA Form No. 7610-1)
  - Copy Attached, Document ID: \_\_\_\_\_
- Acid Rain Part (Form No. 62-210.900(1)(a))
  - Attached, Document ID: \_\_\_\_\_
  - Previously Submitted, Date: \_\_\_\_\_
- Repowering Extension Plan (Form No. 62-210.900(1)(a)1.)
  - Attached, Document ID: \_\_\_\_\_
  - Previously Submitted, Date: \_\_\_\_\_
- New Unit Exemption (Form No. 62-210.900(1)(a)2.)
  - Attached, Document ID: \_\_\_\_\_
  - Previously Submitted, Date: \_\_\_\_\_
- Retired Unit Exemption (Form No. 62-210.900(1)(a)3.)
  - Attached, Document ID: \_\_\_\_\_
  - Previously Submitted, Date: \_\_\_\_\_
- Phase II NOx Compliance Plan (Form No. 62-210.900(1)(a)4.)
  - Attached, Document ID: \_\_\_\_\_
  - Previously Submitted, Date: \_\_\_\_\_
- Phase II NOx Averaging Plan (Form No. 62-210.900(1)(a)5.)
  - Attached, Document ID: \_\_\_\_\_
  - Previously Submitted, Date: \_\_\_\_\_
- Not Applicable

**Additional Requirements Comment**

**ATTACHMENT RGS-EU-I1**  
**Process Flow Diagram**

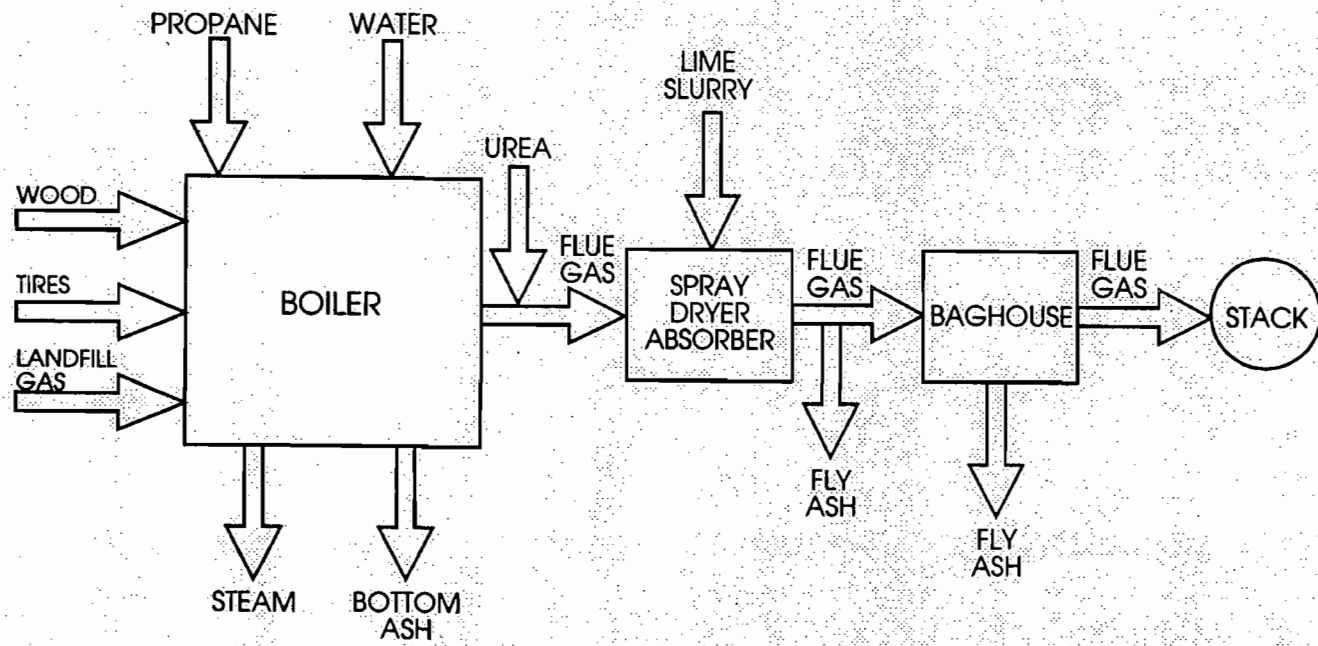

**ATTACHMENT RGE-EU1-I2**  
**Fuel Analysis**

## ATTACHMENT RGE-EU1-I2

### RIDGE GENERATING STATION ESTIMATED ANALYSIS FOR BOILER FUEL COMPONENTS

	Wood <sup>a</sup>	Tires	Landfill Gas
<b>Percent by Weight</b>			
Ash	7.93	6.55	
Sulfur	0.15	1.50	
Hydrogen (H <sub>2</sub> )	3.86	6.78	6.67
Carbon	32.57	78.18	20.00
Water	29.23	1.02	
Nitrogen (N <sub>2</sub> )	0.22	0.12	
Oxygen (O <sub>2</sub> )	25.96	5.86	
Carbon Dioxide			73.33
<b>Heating Value, Btu/lb</b>	<b>5,450</b>	<b>14,000</b>	<b>6,000</b>

<sup>a</sup> These values are for the expected typical wood mix. The heating value of the wood component will vary depending on the mixtures of wood in use.

## ATTACHMENT RGE-EU1-I2

### RIDGE GENERATING STATION ESTIMATED ANALYSIS FOR BOILER FUEL MIXES

	100% Wood <sup>a</sup>	80% Wood 20% Tires <sup>a</sup>	75% Wood 15% Tires 10% Landfill Gas <sup>a</sup>
<b>Percent by Weight</b>			
Ash	7.93	7.81	7.04
Sulfur	0.15	0.27	0.22
Hydrogen (H <sub>2</sub> )	3.86	4.12	4.33
Carbon	32.57	36.62	34.26
Water	29.23	26.73	24.45
Nitrogen (N <sub>2</sub> )	0.22	0.21	0.19
Oxygen (O <sub>2</sub> )	25.96	24.18	22.03
Carbon Dioxide			7.41
Heating Value, Btu/lb	5,450	6,208	6,061

<sup>a</sup> Percentages on a heat input basis.

Note: The heating values will vary depending on the mixtures of wood in use.



**ATTACHMENT RGS-EU1-I3**  
**Detailed Description of Control Equipment**

## ATTACHMENT RGS-EU1-I3

### Detailed Description of Control Equipment

#### SPRAY DRYER ABSORBER

Flue gas enters the top of the Spray Dryer Absorber (SDA) through a diverging cone section and into the vessel. A total of three, multiple port two-fluid nozzles spray the atomized slurry down the center of the vessel, parallel to the gas flow. The flue gas and the evaporating slurry droplets pass down the vessel to the hopper. The flue gas makes a 90° turn and exits the SDA and enters the Fabric Filter (FF). Some of the entrained flyash and dried reaction products fall out of the flue gas and are discharged from the SDA hopper.

The SDA is designed to provide 12 seconds flue gas residence time based on the design gas flow rate.

#### Gas Distribution

Flue gas enters the top of the SDA and passes through a distribution section to evenly distribute the flue gas across the spray dryer absorber cross section at the slurry injection point. The flue gas elbow above the SDA utilizes turning vanes. The flue gas distribution section consists of two (2) banks of chevrons. The turning vanes and chevrons are constructed of abrasion-resistant steel.

#### Atomizing Nozzles

The SDA is provided with three multiple port two-fluid nozzles. Each two-fluid nozzle consists of a stainless steel (630) head with multiple, two-fluid nozzle inserts. Each nozzle is provided with a supporting lance assembly consisting of a structural tube and an aerodynamic shroud. The lance firmly positions the nozzle in the dryer and the shroud minimizes the external buildup of ash on the nozzle. The nozzle assembly is flange mounted on the SDA, and has quick disconnects for slurry, dilution water and compresses air.

The SDA operates using three nozzle heads, each with many inserts.

#### SDA Process Control

The main control loops for the SDA are total slurry feed control and the control of the mixture of concentrated lime slurry and dilution water, which is designed to maintain the guaranteed SO<sub>2</sub>

emission limits.

Atomizing Air Flow is controlled using a flow controller utilizing Flow Control Valve based on a feed back signal from a flow transmitter.

#### FABRIC FILTER

The fabric filter is a continuous automatic type dust collector capable of filtering dust laden air through a porous filter media.

The dirty or contaminated air enters the dust collector through the module inlet, the air is distributed uniformly throughout the housing and heavy particulate drops into the hopper. The dust laden air then passes through a number of filter elements which retain the dust particles on the exterior surface while allowing the clean air to pass through to the module outlet.

As the collector operates, the collected dust begins to form a dust cake in the filter element which diminishes the ability of the filter element to pass air. This increased resistance is measured by a U-Tube manometer or pressure gauge and is defined as the differential pressure. As the differential pressure increases, the system pressure loss will increase, decreasing the ventilation volume.

To maintain the correct pressure drop, a cleaning cycle is employed to provide continuous cleaning of the filter element. This is accomplished by a timer which energizes solenoids activating the diaphragm valves. The diaphragm valves deliver a momentary pulse of compressed air through the manifold pipe and into the venturies. The venturies, which act as natural jet pumps, induce secondary air several times the original volume. This provides efficient cleaning.

This cleaning process occurs in a row by row basis, thus, only a fraction of the total filter air is interrupted for cleaning, allowing continuous ventilation.

The dust cake when pulsed from the filter elements falls directly in to the hopper where it is removed.

#### SELECTIVE NON-CATALYTIC REDUCTION (SNCR)

The SNCR process incorporates a reagent storage and delivery system to inject the urea solution into the combustion gases of the boiler. Concentrated urea solution is delivered by truck and transferred into the chemical storage tank.

The chemical storage tank is a closed top vertical tank, approximately 144" in diameter x 216" overall height, with a nominal capacity of 14,000 gallons. The tank is fabricated of fiberglass reinforced plastic. The tank is supplied with 2 manways, one at the top of the tank and one 30"

from the bottom of the tank. Each manway is 24" in diameter. The tank is also equipped with a ladder, lifting and hold down lugs, the necessary connections, fill pipe, vent, level instrumentation, heat tracing and 2" of insulation.

The storage tank will be filled from heated, self unloading tanker trucks. These trucks are capable of supplying the necessary pumping force to transfer the reagent to the storage tank. Approximately 4,000 gallons is delivered per truck load.

The Circulation Module serves the SNCR process in a dual role. Its primary purpose is to supply urea to the Metering Module. It also has the secondary purpose of keeping the chemical above 80°F, through constant circulation and a circulation heater. The Module is skid mounted and fully shop tested. It consists of two centrifugal pumps, an electric in-line heater, one local control panel, pressure and flow indicators, and all associated stainless steel pipe, tubing and valves. The low flow condition at the Module will shut down the SNCR system.

The circulation heater is controlled by a thermostat and is preset to a temperature of 80°F. When a pump is running and the temperature falls below the set point, the heater will automatically activate, provided the heater is in the on position. There are temperature and pressure indicators provided for monitoring the system operating conditions.

The (2) Metering Modules are skid mounted units used to supply mixed urea to the (3) Distribution Modules. These units are also prepackaged and shop tested. They include chemical metering pumps, regenerative turbine pumps to supply water pressure boost, in-line mixers, and a local control panel. At the discharge of the boost pump is a recirculation loop with a manual regulating valve to properly control the flow and pressures to the Distribution Modules. In addition, the Modules contain all necessary valves, check valves, pressure and flow switches and stainless steel piping/tubing to make it a self-contained metering and pumping system.

NO<sub>x</sub> reduction is a function of the chemical feed rate, which is controlled by varying the speed of the metering pumps through a 4-20 ma signal. The main control for the Metering Module is provided by the Local Control Panel. The system will operate in local or remote mode. In the local mode, instrumentation and electrical control is performed at the module. In the remote mode, control is performed from the plant DCS. The Module also has a hand/auto mode associated with the metering pump and the water boost pump. When the system is in auto and is turned off, the chemical pump will stop, the chemical valve closes and an automatic water flush occurs. In any mode, the pumps will shutdown for low air pressure, low chemical flow, or low water flow. A low low tank level alarm will shut the Metering Module down in the Auto Mode. The flow control for the metering pump also has a local and remote mode. In the remote mode, the metering pump receives a 4-20 ma signal from the plant DCS which controls the pump motor speed. This controls the chemical feed rate. In the local mode, metering pump control is performed at the local control panel using the digital flow controller. The DCS is disabled. Chemical totalization is provided on the flow indicator.

Mixed urea is transported from the (2) Metering Modules to the appropriate Distribution Module, which channel the urea mixture to each individual injector. A total of (16) injectors have been

provided, (14) operational and (2) complete spares. The Distribution Modules and Injectors are arranged as listed below.

Distribution Module #1A	Injectors 1A, 1B, 1C, 1D
Distribution Module #1B	Injectors 1E, 1F, 1G, 1H
Distribution Module #2	Injectors 2I, 2J, 2K, 2L, 2M, 2N

Plant air is piped to each of the Distribution Modules for use as atomizing and cooling air. Flow meters, metering valves, and regulators accurately control and display the chemical, atomizing air, and cooling air to each injector. Also contained on these Modules are the necessary manual ball valves, gauges and stainless steel tubing required to adequately control the urea injection process.

An individual injector consists of an atomizing chamber in which the urea mixture and the air first combine. The mixed chemical is deflected off an internal orifice plate and continuously atomized by the addition of the atomizing medium, plant air (up to 100 psig may be necessary). The atomized chemical then flows through the injector tube to the nozzle. The nozzle is specially designed and characterized to meet the appropriate plant conditions at each injector location. This is done by detailed computer analysis of the temperature, combustion and gas velocity profiles in the boiler. The atomized urea reagent then enters the boiler and mixes with the boiler flue gas to form nitrogen, carbon dioxide and water. Air is required for cooling any time the injectors are in operation and not retracted from the boiler. The injectors are equipped with quick disconnects and hydraulic hoses for flexibility and ease of maintenance.

In addition, each injector has an outer cooling shield. This shield is ceramic coated and is attached to the atomizing chamber. Plant air is fed into the cooling shield at low volume and pressure, acting as a coolant for the nozzle. The shield minimizes direct contact between the corrosive flue gas and the injector. This maximizes the useful life of the nozzle in a hostile environment.

Injectors not expected to be used for extended periods of time should be withdrawn from the boiler and placed on standby to eliminate the possibility of damage from corrosion and overheating. Injectors out-of-service for short periods of time, eg: several hours, can be left in place provided cooling and atomizing air flows are maintained. In the event of loss of cooling/atomizing air, the injectors should be withdrawn from the boiler as quickly as possible. The ceramic coated cooling air jacket should provide sufficient protection if the injectors are withdrawn within a few minutes of loss of air flow.

Loss of mixed chemical flow to injectors is not considered to be a problem as long as air flow is maintained. However, in the event of loss of mixed chemical flow, it is desirable to purge the liquid lines with water to avoid overheating and decomposition of urea within the injector and/or nozzle. Such decomposition products could ultimately plug the nozzle orifice. The water flush eliminates the possibility of chemical crystallization in the transfer lines, when the system is down.

**ATTACHMENT RGE-EU1-I4**  
**Procedures for Startup and Shutdown**

## ATTACHMENT RGE-EU1-I4 Procedures for Startup and Shutdown

### START-UP

1. Feedwater Supply
  - a. Check all feedwater supply equipment to insure a continuous and adequate supply of chemically treated and deaerated feedwater to the boiler.
  - b. Note the pressure on the pump suction to ensure proper suction pressure at the feedwater temperature. (Consult Pump Operating Manual).
  
2. Valve Settings
  - a. Inspect the unit noting the position of all valves. All valves on blowdown lines, continuous blowdown, water column and gage glass drains, and feedwater regulator should be closed.
  - b. Initially, feedwater should be introduced around the feedwater regulator or through the feedwater regulator bypass.
  - c. Insure vents and drains on the inlet header are opened slightly and the vent on the outlet header is opened fully.
  - d. Check valves between drum and water columns and gage glass valves to insure they are open.
  - e. Trace feedwater piping from supply to boiler insuring that proper valves are opened or closed as appropriate.
  
3. Filling With Water
  - a. Fill the boiler to about 2 inches below normal operating level, thus allowing room for expansion of water with heating and pressure rise. NOTE: It is desirable to fill the boiler with properly treated feedwater which has been deaerated. Filling with hot water is permissible providing water is added slowly and flow does not exceed capacity of deaerating heater.

- b. When filling with water, insure the drum vent is opened to permit escape of steam or air.

4. Lighting Off

- a. Once the boiler has been filled with water, light the light fire observing the rules of caution for propane use.
- b. Place all firing equipment on hand control until after unit has been placed on the line.
- c. Position dampers to bypass the air heater.
- d. Insure proper furnace draft either by natural means or induced draft fan.

5. Placing in Operation

- a. Warm line as follows:
  - 1. Raise the steam pressure on the entire piping system with the boiler by opening the header gate valve, non-return valve, and all drip valves prior to steaming.
  - or
  - 2. Raise boiler pressure almost to line pressure, open drips in system, open the gate valve bypass, and slowly open non-return valve allowing steam to flow through the gate valve bypass thus warming the line slowly.
- b. When line has been warmed and evidence of moisture has disappeared, slowly open gate valve admitting full steam flow to the line.
- c. Close gate valve bypass and drip valve.

6. Increasing Load

- a. After boiler has been placed on the line, close all drips, drum and superheater vents, and increase fires slowly.



- b. Gradually increase boiler loading manually up to about 30 percent of rating, and place on automatic control.
- c. Before placing feedwater regulator in service, blowdown the temperature element and allow the system to come to equilibrium.

7. Placing Air Heaters in Service

- a. Close air bypass slowly to prevent sudden temperature reductions in air heater tubing.

**SHUTDOWN**

1. Reduce Load

- a. Reduce boiler steaming rate slowly.
- b. When unit reaches 25 to 30 percent of the rated capacity, place the fuel and air hand control before proceeding to reduce the load further.
- c. Cut the fuel supply when load has been reduced as much as practical.
- d. Allow all fuel to burn out while allowing fans to purge the furnace until all fuel is completely burned.
- e. Place feedwater on hand control and maintain normal water level.

2. Cutting Off Line

- a. As soon as the automatic stop check valve closes, open and throttle out superheater header drain to allow circulation through the superheater until the furnace temperature drops below the point at which overheating of the superheater elements may occur.
- b. Close all inlet and outlet dampers to the boiler to retain heat in the furnace, thus allowing temperatures to drop slowly.
- c. Close feedwater valves when boiler ceases to require water.

- d. When the drum pressure reaches just above atmospheric, open drum vents and superheater drains.
- e. Drain the boiler when boiler water reaches 200 °F or lower.

**ATTACHMENT RGS-EU1-I5**  
**Operation and Maintenance Plan**

# ATTACHMENT RGS-EU1-I5

## Operation and Maintenance Plan

### RIDGE GENERATING STATION

The plant shall be operated and maintained consistent with good engineering practices to ensure the air permit limitations are not exceeded during normal operations and excursions are minimized during malfunction or upset conditions.

Incoming fuel deliveries shall be inspected on a random basis to ensure only permitted fuel materials are accepted at this facility in accordance with the Fuel Management Plan. The tire and wood fuel stocks shall be managed in accordance with the Fuel Management Plan and the Mosquito Control Plan.

Solid fuel weight infeeds to the boiler front shall be monitored continuously and recorded to maintain the various fuels within their individual permit limits. Propane fuel consumption shall be monitored by recording tank levels and propane deliveries for each day.

The combustion process shall be controlled in accordance with the manufacturer's manuals and the Wheelabrator Ridge Energy Operations and Maintenance Manual to minimize CO emissions for the desired operating load, fuel mix, and fuel quality.

The Selective Non-Catalytic Reduction System for NO<sub>x</sub> reduction shall be operated and maintained in accordance with the manufacturer's manuals and the Wheelabrator Ridge Energy Operations and Maintenance Manual to maintain NO<sub>x</sub> emissions within the permit limitations. Urea or urea compounds may be used as the reagent.

The Flue Gas Scrubber System, including the Spray Dryer/Absorber and the Lime Preparation System, shall be operated and maintained in accordance with the manufacturer's manuals and the Wheelabrator Ridge Energy Operations and Maintenance Manual to maintain SO<sub>2</sub> emissions within the permit limits. The system shall also be operated to protect the Fabric Filter from excessive temperatures.

The Fabric Filter shall be operated and maintained in accordance with the manufacturer's manuals and the Wheelabrator Ridge Energy Operations and Maintenance Manual to maintain particulate emissions within the permit limits.

The Continuous Emissions Monitoring System (CEMS) shall be operated and maintained in accordance with the manufacturer's manuals, the Wheelabrator Ridge Energy Operations and Maintenance Manual, and the Quality Assurance/Quality Control Procedure to maintain the accuracy and validity of the CEMS data. The CEMS system is the method of demonstrating compliance with permitted emission limitations.

**RGS-EU1-I6**  
**Identification of Applicable Requirements**

Wheelabrator Ridge Energy Inc.  
Ridge Generating Station  
Facility ID No.: 1050216  
Polk County

Initial Title V Air Operation Permit  
FINAL Permit No.: 1050216-001-AV  
**Administrative Correction - Project No. 003**

Permitting Authority:  
Florida Department of Environmental Protection  
Southwest District  
3804 Coconut Palm Drive  
Tampa, FL 33619  
Telephone: 813/744-6100  
Fax: 813/744-6458

[electronic file name: 1050216f.lac]

Initial Title V Air Operation Permit  
 FINAL Permit No.: 1050216-001-AV  
 Administrative Correction - Project No. 003

Table of Contents

Section	Page Number
Cover Page .....	i
Table of Contents .....	ii
Placard Page (DEP letterhead) .....	1
<b>I. Facility Information</b> .....	<b>2</b>
A. Facility Description	
B. Summary of Emissions Unit ID No(s) and Brief Description(s)	
C. Relevant Documents	
<b>II. Facility-wide Conditions</b> .....	<b>3 - 7</b>
<b>III. Emissions Unit(s) and Conditions</b>	
A. 001 Boiler .....	A1 - A5
B. <del>002 003</del> Lime Silo	
<del>003 Ash Handling System</del>	
<del>004 Fuel Building</del> .....	B1 - B2
<b>IV. Appendices and Attachments (listed in sequence as attached)</b>	
Appendix I-1, List of Insignificant Emission Units and/or Activities	
Appendix TV-1, Title V Conditions	
Appendix SS-1, Stack Sampling Facilities	
Appendix A-1, Abbreviations, Definitions, Citations, and ID Numbers	
Appendix H-1, Permit History/ID Number Transfers	
Figure 1 - Summary Report - Excess Emissions and Monitoring Sys. Performance	
Table 297.310-1 Calibration Schedule	
Table 1-1, Summary of Air Pollutant Standards and Terms	
Table 2-1, Summary of Compliance Requirements	

Permittee:  
Wheelabrator Ridge Energy Inc.  
3131 K-Ville Avenue  
Auburndale, FL 33823

FINAL Permit No.: 1050216-001-AV  
**Administrative Correction - Proj. No. 003**  
Facility ID No.: 1050216  
SIC Nos.: 49,4911  
Project: Initial Title V Air Operation Permit

This **ADMINISTRATIVELY CORRECTED** permit is for the operation of the Wheelabrator Ridge Energy Inc. (Ridge Generating Station) facility. **The administrative corrections in this permit are to clarify permit requirements & rule requirements, correct an emission unit's ID number (002 to 003), and change 2 regulated emission activities to insignificant emission activities. Deletions are shown as "STRIKETHROUGH" and additions are shown in "BOLD".** This facility is located at 3131 K-Ville Avenue, Auburndale, Polk County; UTM Coordinates: Zone 17, 416.7 km East and 3100.4 km North; Latitude: 28° 01' 40" North and Longitude: 81° 50' 51" West.

STATEMENT OF BASIS: This Title V air operation permit is issued under the provisions of Chapter 403, Florida Statutes (F.S.) and Florida Administrative Code (F.A.C.) Chapters 62-4, 62-210, and 62-213. The above named permittee is hereby authorized to perform the work or operate the facility shown on the application and approved drawing(s), plans, and other documents, attached hereto or on file with the permitting authority, in accordance with the terms and conditions of this permit.

Referenced attachments made a part of this permit:

Appendix I-1, List of Insignificant Emissions Units and/or Activities  
APPENDIX TV-1, TITLE V CONDITIONS (version dated 12/02/97)  
APPENDIX SS-1, STACK SAMPLING FACILITIES (version dated 10/7/96)  
TABLE 297.310-1, CALIBRATION SCHEDULE (version dated 10/7/96)  
FIGURE I - SUMMARY REPORT - GASEOUS AND OPACITY EXCESS EMISSION  
AND MONITORING SYSTEM PERFORMANCE REPORT (version dated 7/96)

Effective Date: August 16, 1999

**Administrative Correction Effective Date: February 16, 2000**

Renewal Application Due Date: February 19, 2004

Expiration Date: August 16, 2004



JLM

FLORIDA DEPARTMENT OF  
ENVIRONMENTAL PROTECTION

(W.C. Thomas)

W.C. Thomas, P.E.  
District Air Program Administrator

Section I. Facility Information.

Subsection A. Facility Description.

This facility consists of one boiler firing wood, yard waste, landfill gas, and tires, and one lime silo, ~~one ash handling system, and one fuel building.~~

Also included in this permit are miscellaneous insignificant emissions units and/or activities.

Based on the initial Title V permit application received June 17, 1996, this facility is a major source of hazardous air pollutants (HAPs).

Subsection B. Summary of Emissions Unit ID No(s). and Brief Description(s).

<u>E.U. ID</u>	<u>Brief Description</u>
No. -001	Boiler
<del>-002</del> -003	Lime Silo
<del>-003</del>	Ash Handling System
-004	Fuel Building

*Please reference the Permit No., Facility ID No., and appropriate Emissions Unit(s) ID No(s) on all correspondence, test report submittals, applications, etc.*

Subsection C. Relevant Documents.

The documents listed below are not a part of this permit; however, they are specifically related to this permitting action.

These documents are provided to the permittee for information purposes only:

Table 1-1, Summary of Air Pollutant Standards and Terms

Table 2-1, Summary of Compliance Requirements

Appendix A-1, Abbreviations, Acronyms, Citations, and Identification Numbers  
Appendix H-1, Permit History/ID Number Transfers  
These documents are on file with permitting authority:  
Initial Title V Permit Application received June 17, 1996  
Revised Title V Permit Application received December 3, 1998

Section II. Facility-wide Conditions.

The following conditions apply facility-wide:

1. APPENDIX TV-1, TITLE V CONDITIONS, is a part of this permit.  
{Permitting note: APPENDIX TV-1, TITLE V CONDITIONS, is distributed to the permittee only. Other persons requesting copies of these conditions shall be provided one copy when requested or otherwise appropriate.}
2. Not federally enforceable. General Pollutant Emission Limiting Standards. Objectionable Odor Prohibited. The permittee shall not cause, suffer, allow, or permit the discharge of air pollutants which cause or contribute to an objectionable odor.  
[Rule 62-296.320(2), F.A.C.]
3. General Particulate Emission Limiting Standards. General Visible Emissions Standard. Except for emissions units that are subject to a particulate matter or opacity limit set forth or established by rule and reflected by conditions in this permit, no person shall cause, let, permit, suffer or allow to be discharged into the atmosphere the emissions of air pollutants from any activity, the density of which is equal to or greater than that designated as Number 1 on the Ringelmann Chart (20 percent opacity). EPA Method 9 is the method of compliance pursuant to Chapter 62-297, F.A.C.  
[Rules 62-296.320(4)(b)1. &4., F.A.C.]
4. Prevention of Accidental Releases (Section 112(r) of CAA). If required by 40 CFR 68, the permittee shall submit to the implementing agency:
  - a. a risk management plan (RMP) when, and if, such requirement becomes applicable;  
and
  - b. certification forms and/or RMPs according to the promulgated rule schedule.[40 CFR 68]
5. Insignificant Emissions Units and/or Activities. Appendix I-1; List of Insignificant Emissions Units and/or Activities, is a part of this permit.  
[Rules 62-213.440(1), 62-213.440(6), and 62-4.040(1)(b), F.A.C.]

6. Reasonable precautions to prevent emissions of unconfined particulate matter at this facility include: vehicular traffic areas such as roads and parking areas are paved, areas that have been disturbed are revegetated, all conveyor systems are covered and maintained

to minimize leaks, facility roads are swept, water is applied to the truck dumps and the stacker discharge, as needed, and ash trucks are covered during transport.

[Rule 62-296.320(4)(c)2., F.A.C.; Proposed by applicant in the initial Title V permit application received June 17, 1996; Air Construction Permit AC53-253092]

7. Excess emissions resulting from startup, shutdown or malfunction of any source shall be permitted providing (1) best operational practices to minimize emissions are adhered to (2) the duration of excess emissions shall be minimized but in no case exceed two hours in any 24 hour period unless specifically authorized by the Department for longer duration.

[Rule 62-210.700(1), F.A.C.]

{Permitting Note: This rule is not applicable to sources subject to PSD, NSPS, NESHAP regulations.}

8. Excess emissions which are caused entirely or in part by poor maintenance, poor operation, or any other equipment or process failure which may reasonably be prevented during startup, shutdown, or malfunction shall be prohibited.

[Rule 62-210.700(4), F.A.C.]

9. A statement that a situation arising from sudden and unforeseeable events beyond the control of the source which causes an exceedance of a technology-based emissions limitation because of unavoidable increases in emissions attributable to the situation and which requires immediate corrective action to restore normal operation, shall be an affirmative defense to an enforcement action in accordance with the provisions and requirements of 40 CFR 70.6(g)(2) and (3).

[Rule 62-213.440(1)(d)5, F.A.C.]

#### Test Methods and Procedures

10. Compliance with the monitoring requirements of this permit for monitoring equipment not previously installed prior to issuance of this permit shall commence on the date of the next required compliance test after issuance of this permit.

[Rule 62-213.440(1)(b), F.A.C.]

11. The requirements for stack sampling facilities, source sampling and reporting, shall be in accordance with Chapter 62-297, F.A.C., *Stationary Sources - Emission Monitoring* and 40 CFR 60, Appendix A.  
[Rule 62-297.401, F.A.C.]

12. The visible emissions test shall be conducted by a certified observer and be a minimum of thirty minutes in duration, unless otherwise specified within. The test observation period shall include the period during which the highest opacity can reasonably be expected to occur.  
[Rule 62-297.310(4)(a)2, F.A.C.]

13. Testing of emissions shall be conducted with the source operating at permitted capacity. Permitted capacity is defined as 90-100 percent of the maximum operating rate allowed by the permit. If it is impracticable to test at permitted capacity, then sources may be tested at less than capacity; in this case subsequent source operation is limited to 110 percent of the test load until a new test is conducted. Once the unit is so limited, then operation at higher capacities is allowed for no more than 30 consecutive days for the purposes of additional compliance testing to regain the permitted capacity in the permit. In no case shall the process or production rate exceed the maximum permitted process or production rate. The actual process or production rate during the test shall be included in each test report. Failure to include the actual process or production rate in the results may invalidate the test. In addition, the test results shall include any operating parameters limited or specified to be recorded in this permit, e.g., scrubber flow rate.  
[Rule 62-4.070(3), F.A.C.]

{Permitting Note: Compliance Test Dates. Compliance test dates for emissions units in this permit are for planning purposes only. Rule 62-297.310(7)(a)4, F.A.C., allows the permittee to conduct a formal compliance test any time during the federal fiscal year (October 1 -- September 30).}

14. If the Department of Environmental Protection has reason to believe that any applicable emission standard is being violated, then the Department of Environmental Protection may require the permittee to conduct compliance tests which identify the nature and quantity of pollutant emissions and to provide a report on the results of the tests.  
[Rule 62-297.310(7)(b), F.A.C.]

Recordkeeping and Reporting Requirements

15. The permittee shall notify the Air Compliance Section of the Southwest District Office of the Department at least 15 days prior to the date on which each formal compliance test is to begin of the date, time, and place of each such test, and the contact person who will be responsible for coordinating and having such test conducted.  
[Rule 62-297.310(7)(a)9, F.A.C.]

16. The permittee shall submit to the Air Compliance Section of Southwest District Office of the Department each calendar year, on or before March 1, a completed DEP Form 62-213.900 (5), an "Annual Operating Report for Air Pollutant Emitting Facility", for the preceding calendar year containing the following information pursuant to Subsection 403.061(13), F.S.:

- a. Annual amount of materials and/or fuels utilized;
- b. Annual emissions (note calculation basis);
- c. Hours of operation;
- d. Any changes in the information contained in the permit.

The annual "Statement of Compliance: (ref. Appendix TV-1, item 52) shall be submitted with the AOR.

[Rule 62-210.370(3), F.A.C., ref. Appendix TV-1, item 23]

17. Test Reports

a. The owner or operator of an emissions unit for which a compliance test is required shall file a report with the Air Compliance Section of Southwest District Office of the Department, and the applicable local program(s) on the results of each such test.

b. The required test report shall be filed with the Department as soon as practical but no later than 45 days after the last sampling run of each test is completed or with the operating permit application, whichever is earlier.

c. The report shall provide sufficient detail on the emissions unit tested (at a minimum, the "Project", "Facility ID" and "Point ID"), the test procedures used to allow the Department to determine if the test report was properly conducted and the test results properly computed. Testing procedures shall be consistent with the requirements of Rule 62-297.310(7), F.A.C.

d. The test report, other than for an EPA or DEP Method 9 test, as a minimum, shall provide the following information:

1. The normal type and amount of fuels used and materials processed, and the types and amounts of fuels used and material processed during each test run.
2. The normal operating parameters of air pollution control devices installed on each emission unit (e.g., pressure drop, scrubber liquid flow rate, scrubber

liquid pressure, total current, etc.), and the operating parameters of air pollution control devices during each test run.

Failure to submit the rates and actual operating conditions in the test report may invalidate the test and fail to provide reasonable assurance of compliance.  
[Rules 62-297.310(8), F.A.C., and 62-4.070(3), F.A.C.]

18. Hours of Operation - Unless otherwise noted, all emission units are allowed to operate continuously, i.e., 8760 hours per year.  
[Rule 62-4.070(3), F.A.C.]

19. At a minimum, all records and logs required by this permit shall be updated monthly. (Also reference appendix TV-1, items 12.(14)(b) and (c) and 43.)  
[Rule 62-4.070(3), F.A.C.]

20. When appropriate, any recording, monitoring, or reporting requirements that are time-specific shall be in accordance with the effective date of the permit, which defines day one.  
[Rule 62-213.440, F.A.C.]

21. The permittee shall submit all compliance related notifications and reports required of this permit to the Department's Southwest District office:

Department of Environmental Protection  
Southwest District Office  
3804 Coconut Palm Drive  
Tampa, Florida 33619-8218  
Telephone: 813/744-6100  
Fax: 813/744-6458

22. Any reports, data, notifications, certifications, and requests required to be sent to the United States Environmental Protection Agency, Region 4, should be sent to:

United States Environmental Protection Agency  
Region 4  
Air & EPCRA Enforcement Branch  
61 Forsyth Street  
Atlanta, Georgia 30303  
Telephone: 404/562-9155  
Fax: 404/562-9163

Wheelabrator Ridge Energy Inc.  
Ridge Generating Station  
Page 8 of 7

FINAL Permit No.: 1050216-001-AV  
Administrative Correction - Proj. No. 003

23. This facility is subject to the provisions of 40 CFR 60 Subpart A - General Provisions. A copy of 40 CFR 60 Subpart A - General Provisions is available from the Department upon request.

NOTES to PERMITTEE:

Please reference the Permit No., Facility ID No., and appropriate Emissions Unit(s) ID No(s) on all correspondence, test report submittals, applications, etc.

Table 1-1; Summary of Air Pollutant Standards and Terms, summarizes information for convenience purposes only. This table does not supersede any of the terms or conditions of this permit.

Table 2-1; Summary of Compliance Requirements, summarizes information for convenience purposes only. This table does not supersede any of the terms or conditions of this permit.

Permit Renewal - Reference Appendix TV-1, item 5

Section III. Emissions Unit(s) and Conditions.

Subsection A. This section addresses the following emissions unit(s).

E.U.

<u>ID No.</u>	<u>Brief Description</u>
-001	Boiler

The Ridge Generating Station consists of a 50-MW multi-fuel, steam-driven electric power plant, with one boiler providing the total steam production. The boiler burns a mixture of wood, tires, and landfill gas. Sulfur dioxide emissions from the boiler are controlled by a spray dryer absorber. Particulate matter emissions are controlled by a fabric filter.

{Permitting note(s): This emissions unit is regulated under NSPS - 40 CFR 60, Subpart Db, Standards of Performance for Industrial-Commercial-Institutional Steam Generating Units, adopted and incorporated by reference in Rule 62-204.800(7)(b)3., F.A.C.; NSPS - 40 CFR 60, Subpart Ea, Standards of Performance for Municipal Waste Combustors for which Construction is Commenced after December 20, 1989 and on or before September 20, 1994, adopted and incorporated by reference in Rule 62-204.800(7)(b)6., F.A.C.; Rule 62-212.300, F.A.C., General Preconstruction Review Requirements; Rule 62-212.400, F.A.C., Prevention of Significant Deterioration (PSD); and Rule 62-296.416, F.A.C., Waste-to-Energy Facilities.}

The following specific conditions apply to the emissions unit(s) listed above:

Essential Potential to Emit (PTE) Parameters

A.1. Capacity. The maximum capacity of the boiler is limited to 50 Megawatts (approximately equivalent to 630 MMBtu per hour).  
[Rule 62-4.160(2), F.A.C. and Rule 62-210.200, F.A.C., Definitions - (PTE)]

A.2. Methods of Operation - (i.e., Fuels).

Fuel for firing the boiler shall consist only of wood (as defined in 40 CFR 60, Subpart Db) yard waste, landfill gas, and tires. The tire firing rate shall be limited to 18,505 pounds of tires per hour, based on a 24-hour block average. Propane may be used as a startup, shutdown, and combustion stabilization fuel and shall not exceed an annual capacity factor of 10 percent of total heat input.

[Rules 62-210.200(228), F.A.C., 62-4.160(2), F.A.C. and 62-213.440(1), F.A.C., AC53-206244/PSD-FL-183A]

{Permitting Note: Wood definition from 40 CFR 60 Subpart Db -- Wood means wood, wood residue, bark, or any derivative fuel or residue thereof, in any form, including, but



not limited to, sawdust, sanderdust, wood chips, scraps, slabs, millings, shavings, and processed pellets made from wood or other forest residues.}

A.3. No municipal type solid waste, as defined in 40 CFR 60, Subpart Ea (except tires, yard waste and waste wood) or hazardous waste, as defined in 40 CFR 261 and Rule 62-730.020, F.A.C., or medical/infectious waste as defined in 40 CFR 60.51c, or biomedical waste as defined in Rule 62-712.200, F.A.C., shall be burned at any time in the boiler. The combined total of tires, yard waste, and any waste wood that is defined as municipal solid waste in 40 CFR 60, Subpart Ea, shall not exceed 30 percent (by weight) of the facility fuel feed stream, as measured on a calendar quarterly basis. [Rule 62-210.200(228), F.A.C., AC53-206244/PSD-FL-183]

Emission Limitations and Standards

A.4 The boiler exhaust gases shall not exceed the following limits.

POLLUTANT	POUNDS PER HOUR	TONS PER YEAR	BASIS FOR COMPLIANCE
SO <sub>2</sub>	65.0	284.7	30-day rolling average CEMS*
NO <sub>x</sub>	90.0	394.2	30-day rolling average CEMS*
CO	200.0	876.0	30-day rolling average CEMS*
VOC	22.1	96.8	EPA Method 25A if test required
HCl	5.0	21.9	EPA Method 26 or 26A if test required
Hg	0.022	0.096	EPA Method 29 or 101A if test required
Pb	0.25	1.1	EPA Method 12 or 29 if test required
Be	0.0063	0.028	EPA Method 29 or 104 if test required
VE	10% opacity		EPA Method 9 – annual
PM/PM <sub>10</sub>	0.0080 gr/DSCF (corrected to 7% O <sub>2</sub> )		EPA Method 5 if test required

[Rule 62-212.400, F.A.C., AC53-206244/PSD-FL-183A]

\*Reference Conditions A.7, A.8, A.11, and A.12

{Permitting Note: The particulate matter and opacity standards apply at all times, except during periods of startup, shutdown, or malfunction. [40 CFR 60.43b(g)]}

Test Methods and Procedures

A.5. Test the boiler exhaust gases for VOC, HCl, Hg, Pb, Be, particulates, and visible emissions annually, on or during the 60 day period prior to February 14. Testing of emissions must be conducted when the emission unit being tested is in operation and the test observation period shall include the period during which the highest opacity emissions can reasonably be expected to occur. The fuel mixture for each compliance test shall be submitted with the test notification to the Department prior to testing (see Condition No. 15). The permittee may request, at the time of notification, that the annual stack tests for , HCl, Hg, Pb, and Be be waived based on prior year(s) test results, except

that stack tests for HCl, Hg, Pb, and Be shall be conducted during the ~~180 day period~~ **8 - 12 month period prior to the expiration date of this permit. Since the renewal application is required to be submitted at least 180 days prior to the expiration date of this permit, testing during the 8 - 12 month time period will be used to demonstrate compliance with the emission limitations and Rule 62-297.310(7)(a)3, F.A.C.**  
[Rules 62-297.310(7)(a)4, F.A.C. and 62-4.070(4), F.A.C.]

A.6. Compliance with the emission limitations of Condition A.4 shall be determined using EPA Methods 1, 2, 3, 4, 5, 6C\*, 7E\*, 9, 10\*, 12, 25A, 26, 26A, 29, 101A, and 104 contained in 40 CFR 60, Appendix A, and 40 CFR 61, Appendix B, and adopted by reference in Rule 62-297, F.A.C. The minimum requirements for stack sampling facilities, source sampling and reporting, shall be in accordance with Rule 62-297, F.A.C., 40 CFR 60, Appendix A, and 40 CFR 61, Appendix B. **\* If required by the Department in accordance with Rule 62-297.310(7)(b), F.A.C. - Special Compliance Tests.**  
[Rule 62-297, F.A.C.]

Continuous Monitoring Requirements

A.7. Continuous monitoring equipment shall be installed and operated to measure and record generator output, furnace temperature, stack opacity, and SO<sub>2</sub>, NO<sub>x</sub> and CO emissions. The tire feed rate in pounds per hour shall be monitored continuously by a commercially available weight detecting system with recording capability. The tire feed rate data shall be maintained and provided to the Department upon request.  
[Rule 62-297.310, F.A.C., AC53-206244/PSD-FL-183]

A.8. The continuous monitoring systems required in specific condition A.7 shall be operated and record data during all periods of operation of the boiler including periods of startup, shutdown, malfunction or emergency conditions, except for continuous monitoring system breakdowns, repairs, calibration checks, and zero and span adjustments. Continuous monitoring systems are subject to the applicable requirements of 40 CFR 60, Subpart A - General Provisions, 40 CFR 60, Subpart Db - Standards of Performance for Industrial-Commercial-Institutional Steam Generating Units, and 40 CFR 60, Subpart Ea - Standards of Performance for Municipal Waste, including but not limited to 40 CFR 60 Appendices B and F.  
[Rule 62-213.440(1), F.A.C., 40 CFR 60.13(a)]

Operating Practices

A.9. In the event of any malfunction resulting in failure of emission control equipment or emission-related process equipment to perform as required by this permit, the operator shall immediately stop the feeding of tires into the boiler and shall use propane firing to maintain a minimum of 1800 degrees F in the combustion zone until all tires in the

system have been combusted. No tires may be re-fed into the boiler following the malfunction until the emission control equipment has been put into proper working order. [Rule 62-210.700, F.A.C., AC53-206244/PSD-FL-183]

A.10. Whenever the baghouse bypass is activated during an on-line operating situation for any reason, the permittee shall within 24 hours provide the Department's Southwest District office with a complete report of the circumstances and reasons for the occurrence and indicating the amounts of pollutants estimated to have been discharged during the bypass period. [Rule 62-4.130, F.A.C., AC53-206244/PSD-FL-183]

Monitoring of Operations

A.11. The permittee shall use a continuous opacity monitor system (COMS) to demonstrate continuous compliance with opacity standards in Condition A.4. [Rule 62-213.440(1), F.A.C.]

{Permitting Note: The averaging time for compliance using the COMS is a 6-minute average.}

A.12. Compliance with nitrogen oxides, sulfur dioxide, and carbon monoxide emissions limits for the boiler shall be demonstrated continuously based upon a 30-day rolling average. The 30-day rolling average shall be determined by calculating the arithmetic average of all hourly emission rates for the 30 successive boiler operating days, except for data obtained during startup, shutdown, and malfunction. [Rule 62-213.440(1), F.A.C.]

Recordkeeping and Reporting Requirements

A.13. The permittee shall submit a written report of emissions in excess of the emission limiting standards as set forth in Condition A.4, for each calendar quarter. The nature and cause of the excessive emissions shall be explained. The report shall be submitted within 30 days following each calendar quarter. If there are no excess emissions during the calendar quarter, the facility shall submit a report semiannually stating that no excess opacity emissions occurred during the semiannual reporting period. **The semiannual report shall be submitted within 30 days following the semiannual reporting period.** [40 CFR 60.49b(h), 40 CFR 60.7(c), Rule 62-4.070(3), F.A.C.]

A.14. The permittee shall submit a quarterly report to the Department within 30 days following each calendar quarter. This report shall contain the 30-day rolling average for SO<sub>2</sub>, CO, and NO<sub>x</sub>, all time periods of boiler operation as well as a statement of CEM and/or boiler malfunction, start-up or shutdown. [Rules 62-4.070(3), F.A.C. and 62-213.440(1), F.A.C.]

A.15. The permittee shall maintain an hourly record of the generator output, and furnace temperature. The permittee shall maintain a daily record of the amount of wood, yard waste, tires (including the weight equivalent based on 24-hour block average), and landfill gas fired in the boiler. All of the above records shall be retained and be made available to the Department upon request.

[Rule 62-4.070(3), F.A.C.]

A.16. The permittee shall record and maintain records of the amounts of each fuel combusted during each day and calculate the annual capacity factor individually for propane, landfill gas, wood, and municipal-type solid waste for each calendar quarter. The annual capacity factor is determined on a 12-month rolling average basis with a new annual capacity factor calculated at the end of each calendar month.

[40 CFR 60.49b(d) and (o), Rule 62-4.070(3), F.A.C.]

A.17. The permittee shall keep a record on a calendar quarter basis of the weight of municipal solid waste combusted and the weight of all other fuels combusted. **Be sure the record contains a "percent value" that demonstrates that the combined total of tires, yard waste, and any waste wood does not exceed 30% (by weight) of the facility fuel feed stream as required by Condition No. A.3.**

[40 CFR 60.49b(d), Rule 62-4.070(3), F.A.C.]

A.18. All test reports submitted to the Department shall include, at a minimum, the following information for the test period:

- a. Type of fuel being fired.
- b. Heat input rate (MMBtu per hour) and firing rate
- c. Generator output (Megawatts).
- d. Temperature in the combustion zone.
- e. Pressure drop across the baghouse (inches of H<sub>2</sub>O).
- f. Stack flow rate (standard cubic feet per minute).

Failure to submit the above information, or operating at conditions which do not reflect normal operating conditions may invalidate the test and fail to provide reasonable assurance of compliance.

[Rule 62-4.070(3), F.A.C.]

A.19. All applicable recordkeeping and reporting requirements of 40 CFR 60, Subpart A - General Provisions, 40 CFR 60, Subpart Db - Standards of Performance for Industrial-Commercial-Institutional Steam Generating Units, and 40 CFR 60, Subpart Ea - Standards of Performance for Municipal Waste Combustors should be met.

[40 CFR 60, Subparts A, Db, and Ea]

Subsection B. This section addresses the following emissions unit(s).

<u>E.U. ID</u>	<u>Brief Description</u>
<del>002</del> 003	Lime Silo
<del>003</del>	Ash Handling System
<del>004</del>	Fuel Building

Lime Silo

Lime is fed from the lime silo into a slaker to form a high solids slurry. After being screened for grit removal, the solids slurry is stored in an agitated tank. The slurry is then pumped to the spray dryer absorber (SDA) where it is diluted before being introduced into an atomizer located at the inlet of the spray dryer absorber.

Ash Handling System

~~Bottom ash is removed using wet drag conveyors. The wetting of the bottom ash minimizes fugitive dust emissions. Solid waste from the sifting hoppers, economizers hoppers, SDA hoppers, and fabric filter hoppers are removed by a combination of screw conveyors and/or drag conveyors.~~

Fuel Building

~~Processed wood passing through the trommel (or screen) and discharging from the secondary hogger is conveyed to the boiler fuel storage bin or stacked out in the processed wood storage area. Fines from the on site processing of wood are collected and disposed of off site.~~

{Permitting note(s): These emissions units are regulated under Rule 62-296.320, F.A.C., General Pollutant Emission Limiting Standards.}

The following specific conditions apply to the emissions unit(s) listed above:

Essential Potential to Emit (PTE) Parameters

B.1. Capacity.

- a. The maximum lime silo loading rate shall not exceed 25 tons per hour.
- b. ~~The maximum operating/process rate for the ash handling system shall not exceed 12.5 tons per hour.~~

[Rule 62-4.160(2), F.A.C. and Rule 62-210.200, F.A.C., Definitions - (PTE)]

Emission Limitations and Standards

B.2. Visible emissions from the lime silo vent filter shall not exceed 10% opacity.  
[Rule 62-212.400, F.A.C., AC53-206244/PSD-FL-183A]

Test Methods and Procedures

B.3. Test the lime silo vent filter exhaust for visible emissions annually, on or during the 60 day period prior to February 14.  
[Rules 62-297.310(7)(a)4, F.A.C. and 62-4.070(4), F.A.C.]

B.4. Compliance with the emission limitations of Condition B.2 shall be determined using EPA Method 9 contained in 40 CFR 60, Appendix A and adopted by reference in Rule 62-297, F.A.C. The minimum requirements for stack sampling facilities, source sampling and reporting, shall be in accordance with Rule 62-297, F.A.C. and 40 CFR 60, Appendix A.  
[Rule 62-297, F.A.C.]

Monitoring of Operations

B.5. The pressure drop across the lime silo baghouse shall be monitored during each compliance test, and a summary of this data shall be included in each emissions test report along with the process/operating data (quantity and type of material transferred).  
[Rule 62-297.310(8), F.A.C.]

Recordkeeping and Reporting Requirements

B.6. In order to document compliance with Condition B.1, the permittee shall maintain the following records:

For Lime Silo loading only:

- a. **daily record the hours of operation, loading the silo for each shipment,**
- b. **daily record the quantity of lime transferred to the silo for each shipment,**
- c. **daily record the lime transfer (loading) rate to the silo in tons/hr. for each shipment,**
- e. ~~the total hours of operation for the year.~~

For the Ash Handling System only:

- a. ~~the hours of operation,~~
- b. ~~the quantity of ash transferred,~~
- e. ~~the total hours of operation for the year.~~

**The daily records shall be completed within 5 business days.** The records shall be made available for inspection by the Department upon request.  
[Rule 62-4.070(3), F.A.C.]

**RGS-EU1-I7**  
**Compliance Assurance Monitoring Plan**

**COMPLIANCE ASSURANCE MONITORING PLAN  
(CAM PLAN)**

**FOR**

**Ridge Generating Station**

**Wheelabrator Ridge Energy Inc.  
Auburndale, Florida**

**November, 2003**



## **I. EMISSION UNITS REQUIRING CAM PLANS**

### ***A. CAM Rule Applicability Definition***

As part of these Title V renewal applications EPA, through regulations adopted in Title 40, Part 64 of the Code of Federal Regulations (40 CFR 64), is requiring submittal of Compliance Assurance Monitoring (CAM) Plans. This regulation has been incorporated by reference by FDEP in Rule 62-204.800 and implemented in Rule 62-213.440.

CAM plans are required for all Title V permitted emission units using control devices to meet federally enforceable emission limits or standards with uncontrolled emissions greater than "major" source thresholds. The term "major" is defined as in the Title V Regulations (40 CFR 70), but applied on a source-by-source basis. However, there are some specific exemptions to the applicability of the CAM Rule.

Specifically exempted from the CAM Rule are emissions units subject to requirements under Stratospheric Ozone Regulations (40 CFR 82), the Acid Rain Program (40 CFR 72), or that are part of an emission cap included in the Title V Permit. Also exempt are emission units subject to New Source Performance Standards (40 CFR 60) and National Emission Standards for Hazardous Air Pollutants (40 CFR 63) promulgated after 11/15/1990, as these sources have CAM equivalent monitoring requirements included as part of the standard.

### ***B. Emissions Units Requiring CAM Plans***

A review of emission units at RGS was conducted to determine the applicability of the CAM Rule. This evaluation was conducted for each emission unit and pollutant. First, the existence of a "control device" as defined by the CAM Rule was determined on a source-by-source basis for each pollutant. Those emission units without control devices were eliminated from further consideration. The remaining emission units were then evaluated on a pollutant-by-pollutant basis to determine if a control device was used to meet a federally enforceable emission limit or standard. Each pollutant without a federally enforceable emission limit or standard, emitted from

a given emission unit, was eliminated from further consideration. Uncontrolled annual emissions were then calculated for each remaining source-pollutant combination. If uncontrolled emissions for a pollutant emitted from a given emission unit source were below major source thresholds as defined by the CAM Rule, that pollutant was not further considered. A summary of the results of this evaluation process is presented in Table 1. Specific exemptions to the applicability of the CAM Rule were also considered in this evaluation.

### **RGS Unit 001 (Boiler)**

RGS Unit 001 is a nominal 50-megawatt multi-fuel boiler. The boiler burns a mixture of wood, tires, and landfill gas. The maximum heat input rate is approximately 630 MMBtu/hr. Sulfur dioxide emissions from the boiler are controlled by a spray dryer absorber. Particulate matter emissions are controlled by a fabric filter. Nitrogen oxides (NO<sub>x</sub>) emissions are controlled by a selective noncatalytic reduction (SNCR).

The unit is not regulated under the Acid Rain, Phase II provisions. The unit is also not regulated under NSPS - 40 CFR 60, Subpart Ea, Standards of Performance for Municipal Waste Combustors for which Construction is Commenced after December 20, 1989 and on or before September 20, 1994, adopted and incorporated by reference in Rule 62-204.800(7)(b)6, F.A.C.; Rule 212.300, F.A.C. RGS is not subject to Subpart Ea because it is subject to a federally enforceable permit limiting combustion of municipal solid waste to 30 percent or less (by weight) of the fuel feed stream as measured on a calendar quarterly basis. RGS Unit 1 is subject to the following requirements of 40 CFR 60 Subpart Db, emission standards for industrial – commercial – institutional steam generating units with heat input capacity greater than 100 MMBtu/hr.:

1. emission standard for particulate matter when combusting wood or a mixture of wood and other fuels; and
2. opacity standard and monitoring requirements.

The General Preconstruction Review Requirements; Rule 62-212.400, F.A.C. Prevention of Significant Deterioration (PSD); is also applicable to RGS Unit 001. Although Unit 001 has

federally enforceable limit for nitrogen oxides and a control device (SNCR), Unit 001 is exempt from CAM for NO<sub>x</sub> because under the Title V permit, RGS is required to monitor NO<sub>x</sub> emissions using a continuous emission monitor (CEM). An emission limitation or standard for which a part 70 or 71 permit specifies a continuous compliance method is exempt from CAM. in accordance with 40 CFR 64.2 (b) (vi);

Although there is a federally enforceable emission limit for SO<sub>2</sub>, and a control device (spray dryer) Unit 001 is exempt from CAM for SO<sub>2</sub> because under the Title V permit, RGS is required to monitor SO<sub>2</sub> emissions via continuous emission monitor (CEM). An emission limitation or standard for which a part 70 or 71 permit specifies a continuous compliance method is exempt from CAM in accordance with 40 CFR 64.2 (b) (vi);

Since a federally enforceable emission limit exists for PM, a control device is used to comply with the PM emission limit, and uncontrolled PM emissions are greater than 100 TPY, a CAM plan is required for Unit 001 for PM.

#### **RGS Unit 002 (Ash Handling System)**

Bottom ash from the boiler is removed using wet drag conveyors. The wetting of the bottom ash minimizes fugitive dust emissions. Solid waste from sifting hoppers, economizer hoppers, SDA hoppers, and fabric filter hoppers are removed by a combination of screw conveyors and or drag conveyors. A wet scrubber is used to control emissions of from the ash handling system. Unit 003 has federally an enforceable limit for visible emissions only and uncontrolled particulate emissions are below the CAM emission threshold, the requirements of CAM are not applicable.

#### **RGS Unit 003 (Lime Silo)**

Lime is fed from the lime silo into a slaker to form a high solids slurry. After being screened for grit removal, the solids slurry is stored in an agitated tank. The slurry is then pumped to the spray dryer absorber where it is diluted before introduced into an atomizer located at the inlet of the spray dryer. A bin vent filter is used to control emissions of from the lime silo. Unit 003 has federally an enforceable limit for visible emissions only and uncontrolled emissions of

particulate are below the CAM emission threshold, therefore the requirements of CAM are not applicable.

## II. PARTICULATE EMISSIONS FROM RGS UNIT 001

### A. Emissions Unit Identification

RGS Unit 001 is a nominal 50-megawatt multi-fuel, boiler. The boiler burns a mixture of wood, tires, landfill gas, and propane for startup or fuel stabilization. The maximum heat input rate is approximately 630 MMBtu/hr. A fabric filter baghouse controls particulate matter emissions.

PM compliance testing is required annually on Unit 001. In addition, a continuous opacity monitoring system (COMS) is required to record the opacity of the stack flue gas, Rule 62-213.440(1), F.A.C. The COMS must be properly calibrated, operated, and maintained in accordance with Rule 62-297.520, F.A.C.

### C. Control Technology Description

PM emissions from Unit 001 are controlled by a fabric filter (baghouse). The effectiveness of the baghouse is evaluated with an annual stack test and continuous opacity measurements. A detailed description of the control equipment is included in the Title V renewal application.

### D. Monitoring Approach

The monitoring approach for particulate emissions to meet the CAM requirements are summarized in the table below. In general, the existing COMS will be used as the basis for CAM.

Indicator No. 1	
Indicator	Opacity via a COMS.
Measurement Approach	40 CFR 60, Appendix B, Performance Specification 1
Indicator Range	An excursion is defined as a Opacity (1-hour block averaging time) greater than 5.0 % for any fuel firing mode, excluding startup shutdown and malfunction periods.  An excursion will trigger an evaluation of operation of the power boiler and baghouse. Corrective action will be taken as

	necessary. Any excursion will trigger recordkeeping and reporting requirements.
Data Representativeness	Opacity is monitored in the duct work prior to the stack. The monitoring location meets the PS-1 monitoring location criteria to provide representative measurements.
Verification of Operational Status	NA
QA/QC Practices and Criteria	The COMS is automatically calibrated every 24 hours. Calibration information is recorded through a data acquisition system (DAS). A neutral density filter test is performed quarterly as well as preventative maintenance items; replace filters, clean optics, etc., as prescribed by the manufacturer.
Monitoring Frequency	Opacity is monitored continuously.
Data Collection Procedures	Six-minute and hourly averages will be recorded by the DAS and displayed on the screen in the control room. Daily reports with all six-minute and hourly averages are generated.
Averaging Period	Opacity hourly block average will be recorded in addition to six-minute block averages.

## *E. Justification*

### **1. Background**

The pollutant specific emission unit is RGS Unit 001, which is fired with a mixture of wood, tires, and landfill gas. It is controlled by a baghouse, which has a control efficiency of 99% or greater.

### **2. Rationale for Selection of Performance Indicator**

Compliance test data for the last 4 years was analyzed to determine if a correlation could be made for particulate grain loading and baghouse pressure drop and particulate grain loading and opacity. Grain loading was plotted versus baghouse pressure drop and opacity and the results can be seen in Table 2 and Figures 1. and 2. As shown by these figures, there is almost no correlation between grain loading or baghouse pressure drop and opacity. Based on the correlation and nature of the data, more test data will not result in a better correlation.

Since a correlation based on test data does not exist, an approach to CAM based on current procedures is proposed using opacity as a relative indicator of optimal fabric filter performance.

Corrective actions will be initiated to ensure opacity levels are minimized and therefore assuring longterm optimal fabric filter performance.

The proposed procedure is as follows:

If the stack opacity exceeds 5% and follows a sustained trend based on a one hour block average (1-hour) or the 6 minute opacity average of 10% is exceeded the following response shall be implemented.

1. The Plant Operator shall monitor the baghouse cleaning cycle to determine which baghouse compartment may be the root cause of the increased opacity. The affected compartment is identified by observing opacity spikes associated with the pulse cleaning of the bags.
2. Primary Action Level
  - a. Close the outlet damper of the affected bag house compartment
  - b. Open the hopper access door.
  - c. Inspect the clean side of tube sheet for any dust accumulation that would identify leaking bag(s).
  - h. Remove and replace any apparent leaking bag(s)
  - i. Close baghouse compartment access and return baghouse compartment to service.
  - j. Verify that opacity levels have returned to less than 5% or that 6-minute opacity averages are restored below opacity limit.
3. Secondary Action Level (if first action level failed to restore opacity levels below 6 minute average limit or 5% 1 hour block average.
  - a. Isolate other compartments one by one and inspect clean side tube sheet for indication of leaking bags. Replace any bags as necessary in affected compartment and return compartment to service.
  - b. b. Observe opacity to see if opacity levels restored to normal conditions.

- c. c. If opacity level is not restored to less than 5% 1 hour average or additional exceedances of the 6 minute average opacity limit are encountered, then fluorescent dye testing will be performed sequentially on each compartment as necessary to identify problem. Fluorescent dye will be introduced into a. each compartment hopper and the clean side tube sheet inspected using a black light source until the problem is found and corrected
- d. Opacity levels will be observed after correction action to verify that opacity levels have returned below 5 % 1-hour averages and that there are no further exceedances of the 6 minute limit.

e

- 4. If the 6-minute opacity limit is exceeded due to startup/shutdown/or malfunction, the plant will determine if corrective action can be taken in the allowed 2-hours of excess emissions due to startup/shutdown/malfunction as per 62-210.700(1) F.A.C. If corrective action will extend beyond 2 hours then the Department will be notified and authorization obtained to continue with corrective action procedures.

### **3. Rationale for Selection of Indicator Ranges**

The selected indicator range is 5.0 % opacity for all firing modes and is equivalent to 1/2 of the permit limit of 10% opacity. Opacity was selected as the performance indicator for CAM because it is good indicator of proper operation and maintenance of the baghouse. When the baghouse is operating properly, opacity levels will be minimal, generally less than 5% taking into account the absolute accuracy and precision of opacity monitoring instrumentation. This indicator range was selected because opacity readings of greater magnitude could indicate impaired baghouse performance and an associated increase in particulate emissions from the baghouse outlet. As discussed, to develop the indicator range, opacity readings were compared with stack test results of PM grain loading (gr/dscf). A correlation could not be developed for a relationship between grain loading and opacity or pressure drop.

When an excursion occurs, corrective action will be initiated, beginning with an evaluation of the occurrence, to determine the action required (if any) to correct the situation. All excursions will be documented and reported in accordance with CAM requirements.



**RGS-EU1-EU8**  
**Alternative Methods of Operation**

Attachment RGS-EU1-EU8  
Alternate Methods of Operation

The RGS facility is allowed to operate at a maximum capacity of 50 Megawatts (approximately equivalent to 630 MMBtu/hr) for 8,760 hours per year.

Fuel for firing the boiler consists of wood, yard waste, landfill gas, and tires. The tire firing rate is limited to 18,505 pounds of tires per hour, based on a 24-hour block average. Propane may be used as a startup, shutdown, and combustion stabilization fuel and shall not exceed an annual capacity factor of 10 percent of total heat input.

The emissions in the RGS boiler exhaust gases are currently limited as follows:

<b>Pollutant</b>	<b>Lbs/hr</b>	<b>Tons/yr</b>	<b>Basis for Compliance</b>
<i>SO<sub>2</sub></i>	<i>65.0</i>	<i>284.7</i>	<i>30-day rolling average CEMS</i>
NO <sub>x</sub>	90.0	394.2	30-day rolling average CEMS
CO	200.0	876.0	30-day rolling average CEMS
VOC	22.1	96.8	EPA Method 25A if required
HCl	5.0	21.9	EPA Method 26 or 26A if required
Hg	0.022	0.096	EPA Method 29 or 101A if required
Pb	0.25	1.1	EPA Method 12 or 29 if required
Be	0.0063	0.028	EPA Method 29 or 104 if required
VE	10% opacity		EPA Method 9 – annual
PM/PM10	0.008 gr/SCF @ 7% O <sub>2</sub>		EPA Method 5 if required

Sulfur dioxide emissions from the boiler are controlled by a spray dryer absorber. Control of SO<sub>2</sub> emissions using absorbent are based on operating load to meet applicable emission limit. Particulate matter emissions are controlled by a fabric filter. Nitrogen oxides (NO<sub>x</sub>) emissions are controlled by a selective non-catalytic reduction (SNCR). Urea is used in the SNCR system and the amount of injection is adjusted based on operating load and NO<sub>x</sub> generated.

During low load operation and when tires are not used as fuel, the SO<sub>2</sub> emissions from the boiler are very low, see attached CEM data for the month of September, 2003. This firing condition exists daily from 0000 to 0900. SO<sub>2</sub> continuous monitor data for the month of September 2003 for periods of low load and zero tire feed indicates a range of SO<sub>2</sub> emissions from 0.0 lb/hr to a maximum of 49.0 lb/hr, with the majority of the readings less than 10 lb/hr.

RGS currently meets the permitted 30-day rolling average SO<sub>2</sub> limit without the use of the spray dry absorber during low load, zero tire fired conditions. Therefore, RGS has the following alternate methods of operation:

- Tires – Absorbent injected based on tire amount and load
- No Tires – No absorbent used; water injected to minimize temperature.

Current Date: 10/01/03  
 Current Time: 00:27

Daily Data Report - Hourly Averages  
 Wheelabrator Ridge Energy  
 09/30/03

Logger Id : 01

Logger Name : Ridge Energy

Interval : 001H

Param :	TIREFEED	O2WET	STKFLOW	MGWATTS	FTEMP	STMFLOW	CO#/HR	NO#/HR	SO2#/HR
Units :	KPPH	VOL%	KSCFM	MW	DEG_F	KPPH	#/HR	#/HR	#/HR
Stack :									
Unit :		Blr1	Blr1	Blr1	Blr1	Blr1	Blr1	Blr1	Blr1
Hour :	-----								
00	-1	10.4	181	22.1	2336	184.7	66.24	61.89	16.99
01	-1	10.6	184	22.4	2336	184.0	73.98	69.81	12.28
02	-1	10.5	187	22.5	2336	184.6	70.85	78.78	8.82
03	-1	10.8	188	21.1	2336	174.8	81.30	79.67	5.57
04	-1	11.1	189	20.5	2336	173.3	105.68	78.44	8.73
05	-1	11.4	188	19.8	2336	168.4	156.67	75.67	5.51
06	-1	11.5	187	19.0	2336	162.4	154.14	75.77	7.72
07	-1	11.7	187	15.4	2336	137.4	315.51	91.97	20.15
08	-1	11.0	181	18.5	2336	153.2	133.53	79.67	16.13
09	-1	11.2	182C	16.4	2336	142.2	242.83C	87.38C	21.79C
10	1.6	11.2C	197	21.8	2334	182.7	209.97C	108.18C	10.01C
11	18.8	9.0	217	39.0	2328	305.2	313.22	112.58	132.23
12	26.5	8.1	216	43.1	2324	337.6	195.13	116.88	124.30
13	23.5	7.4C	216	43.6	2324	341.7	115.49C	124.00C	82.42C
14	25.3	8.0	215	43.2	2314	339.7	127.04	120.83	117.20
15	24.8	8.0	215	42.9	2323	336.4	122.94	116.34	128.02
16	24.6	8.3	216	41.5	2326	324.6	104.47	120.08	116.09
17	23.6	8.3	215	41.7	2319	327.0	123.92	116.85	131.88
18	23.8	8.2	215	42.2	2319	330.8	113.93	115.78	107.96
19	24.7	8.0	213	42.7	2332	333.0	126.83	121.12	66.60
20	22.2	7.6	210	42.5	2321	332.7	67.84	90.31	82.29
21	23.5	7.6	209	43.0	2324	335.9	82.11	89.99	136.50
22	12.4	10.8C	183	17.2	2335	150.3	181.72C	60.66C	56.52C
23	.1	12.0	190	15.0	2336	134.6	446.14	105.12	31.82
ax :	26.5	12.0	217	43.6	2336	341.7	446.14	124.00	136.50
in :	-1	7.4	181	15.0	2314	134.6	66.24	60.66	5.51
ean :	11.4	9.7	199	29.9	2330	240.7	155.48	95.74	60.31
ours :	24	24	24	24	24	24	24	24	24

Status : '<' - Less than ## Data, 'P' - Power Fail, 'D' - Disabled, 'T' - Out-of-Control, 'F' - Boiler Off-Line,  
 'B' - Bad Status, 'C' - Calibration, 'M' - Maintenance, 'O' - Analog Overrange, 'U' - Analog Underrange,  
 'A' - Arithmetic Error, '+' - Maximum, '-' - Minimum, 'R' - Rate of Change, 'H' - High-High Alarm,  
 'L' - Low-Low Alarm, 'h' - High Alarm, 'l' - Low Alarm, 'J' - High Rate of Change, 'j' - Low Rate of Change,  
 'V' - DIS #1 Obs, 'W' - DIS #2 Obs, 'X' - DIS #3 Obs, 'Y' - DIS #4 Obs, 'Z' - DIS #5 Obs.

Current Date: 10/01/03  
Current Time: 00:35

Daily Parameter Report - Aux1  
Wheelabrator Ridge En  
09/30/03

Logger Name: RIDGE  
Logger Id: 01

Stack:  
Boiler/Unit: Opac

Date	Time	00	06	12	18	24
09/30/03	00:00	.00	.00	.00	.00	.00
09/30/03	01:00	.00	.00	.00	.00	.00
09/30/03	02:00	.00	.00	.00	.00	.00
09/30/03	03:00	.00	.00	.00	.00	.00
09/30/03	04:00	.00	.00	.00	.00	.00
09/30/03	05:00	.00	.00	.00	.00	.00
09/30/03	06:00	.00	.00	.00	.00	.00
09/30/03	07:00	.00	.00	.00	.00	.00
09/30/03	08:00	.00	.00	.00	.00	.00
09/30/03	09:00	.00	.00	.00B	.00B	.00
09/30/03	10:00	.00	.00	.00	.00	.00
09/30/03	11:00	.00	.00	.00	.00	.00
09/30/03	12:00	.00	.00	.00	.00	.00
09/30/03	13:00	.00	.00	.00	.00	.00
09/30/03	14:00	.00	.00	.00	.00	.00
09/30/03	15:00	.00	.00	.00	.00	.00
09/30/03	16:00	.00	.00	.00	.00	.00
09/30/03	17:00	.00	.00	.00	.00	.00
09/30/03	18:00	.00	.00	.00	.00	.00
09/30/03	19:00	.00	.00	.00	.00	.00
09/30/03	20:00	.00	.00	.00	.00	.00
09/30/03	21:00	.00	.00	.00	.00	.00
09/30/03	22:00	.00	.00	.00	.00	.00
09/30/03	23:00	.00	.00	.00	.00	.00

Max .05  
Min .00  
Mean .00

Records 240

Status: '<' - Less than ## Data, 'P' - Power Fail, 'D' - Disabled, 'T' - Out-of-Con  
Flags: 'B' - Bad Status, 'C' - Calibration, 'M' - Maintenance, 'O' - Analog Ove  
'A' - Arithmetic Error, 'H' - Maximum, 'L' - Minimum, 'R' - Rate of Ch  
'L' - Low-Low Alarm, 'h' - High Alarm, 'l' - Low Alarm, 'J' - High Rate  
'V' - DIS #1 Obs, 'W' - DIS #2 Obs, 'X' - DIS #3 Obs, 'Y' - DIS #4 Obs

Current Date : 09/30/03  
 Current Time : 00:27

Daily Data Report - Hourly Averages  
 Wheelabrator Ridge Energy  
 09/29/03

Logger Id : 01

Logger Name : Ridge Energy

Interval : 001H

Param :	TIREFEED	O2WET	STKFLOW	MGWATTS	FTEMP	STMFLOW	CO#/HR	NO#/HR	SO2#/HR
Units :	KPPH	VOL%	KSCFM	MW	DEG F	KPPH	#/HR	#/HR	#/HR
Stack :									
Unit :	Blr1	Blr1	Blr1	Blr1	Blr1	Blr1	Blr1	Blr1	Blr1
Hour :									
00	-1	13.4	197	13.9	2336	123.3	660.07	104.20	1.96
01	-1	12.6	199	16.7	2336	143.0	560.60	103.30	9.82
02	-1	11.8	189	19.5	2335	162.5	280.20	97.73	2.24
03	-1	11.1	177	21.1	2334	172.8	99.43	95.32	.15
04	-1	10.1	174	23.6	2336	189.7	28.22	104.43	.00
05	.0	10.6	171	21.8	2325	179.2	36.65	87.27	.00
06	.0	10.7	168	20.9	2318	174.2	61.57	84.52	.01
07	-1	10.7	161	18.8	2324	162.1	50.20	72.78	.00
08	-1	10.6	156	18.2	2322	155.7	47.89	85.48	.00
09	-1	10.2	151C	18.2	2310	155.4	31.57C	84.97C	.00C
10	1.9	8.4C	178	29.8	2312	238.3	57.85C	128.63C	54.82C
11	11.5	7.4	206	42.5	2316	330.1	309.80	137.58	40.10
12	20.4	7.0C	204	44.8	2298	349.2	294.04C	141.19C	81.16C
13	21.1	7.9	208	43.0	2311	334.1	85.63	150.99	100.41
14	17.1	8.9	210	40.0	2311	312.4	124.99	142.40	87.94
15	17.9	7.4	203	42.8	2284	336.1	150.00	141.78	78.11
16	19.9	6.7	201	44.2	2304	343.7	405.15	124.45	74.82
17	20.0	6.4	199	44.6	2297	347.6	454.13	118.13	95.03
18	17.9	6.5	202	44.7	2307	347.4	399.24	121.44	110.45
19	18.2	6.8	206	44.9	2320	348.6	109.28	151.60	111.11
20	21.4	7.3	208	43.0	2332	333.9	116.15	133.13	69.71
21	19.6	7.5	209	43.3	2332	336.8	102.09	128.09	71.17
22	13.5	11.4C	193	25.5	2335	206.1	162.93C	71.03C	35.08C
23	1.2	10.8	182	21.8	2336	181.4	106.93	63.69	16.93
Max :	21.4	13.4	210	44.9	2336	349.2	660.07	151.60	111.11
Min :	-1	6.4	151	13.9	2284	123.3	28.22	63.69	.00
Mean :	9.2	9.3	190	31.2	2320	248.5	197.28	111.42	43.38
Hours :	24	24	24	24	24	24	24	24	24

Status : 'C' - Less than 100 Data, 'P' - Power Fail, 'D' - Disabled, 'T' - Out-of-Control, 'F' - Boiler Off-Line,  
 'B' - Bad Status, 'C' - Calibration, 'M' - Maintenance, 'O' - Analog Overrange, 'U' - Analog Underrange,  
 'A' - Arithmetic Error, '+' - Maximum, '-' - Minimum, 'R' - Rate of Change, 'H' - High-High Alarm,  
 'L' - Low-Low Alarm, 'h' - High Alarm, 'l' - Low Alarm, 'J' - High Rate of Change, 'j' - Low Rate of Change,  
 'V' - DIS #1 Obs, 'W' - DIS #2 Obs, 'X' - DIS #3 Obs, 'Y' - DIS #4 Obs, 'Z' - DIS #5 Obs

Current Date : 09/30/03  
 Current Time : 00:35

Daily Parameter Report - Auxiliary Averages  
 Wheelabrator Ridge Energy  
 09/29/03

Logger Name : RIDGE  
 Logger Id : 01

Stack :  
 Boiler/Unit : Opac

Parameter : STAKOPAC  
 Units : PERCENT

Date	Time	00	06	12	18	24	30	36	42	48	54
09/29/03	00:00	.00	.00	.00	.00	.00	.00	.00	.00	.00	.00
09/29/03	01:00	.00	.00	.00	.00	.00	.00	.00	.00	.00	.00
09/29/03	02:00	.00	.00	.00	.00	.00	.00	.00	.00	.00	.00
09/29/03	03:00	.00	.00	.00	.00	.00	.00	.00	.00	.00	.00
09/29/03	04:00	.00	.00	.00	.00	.00	.00	.00	.00	.00	.00
09/29/03	05:00	.00	.00	.00	.00	.00	.00	.00	.00	.00	.00
09/29/03	06:00	.00	.00	.00	.00	.00	.00	.00	.00	.00	.00
09/29/03	07:00	.00	.00	.00	.00	.00	.00	.00	.00	.00	.00
09/29/03	08:00	.00	.00	.00	.00	.00	.00	.00	.00	.00	.00
09/29/03	09:00	.00	.00	.00B	.00B	.00	.00	.00	.00	.00	.00
09/29/03	10:00	.00	.00	.00	.00	.00	.00	.00	.00	.00	.00
09/29/03	11:00	.00	.00	.00	.00	.00	.00	.00	.00	.00	.00
09/29/03	12:00	.00	.00	.00	.00	.00	.00	.00	.00	.00	.00
09/29/03	13:00	.00	.00	.00	.00	.00	.00	.00	.00	.00	.00
09/29/03	14:00	.00	.00	.00	.00	.00	.00	.00	.00	.00	.00
09/29/03	15:00	.00	.00	.00	.00	.00	.00	.00	.00	.00	.00
09/29/03	16:00	.00	.00	.00	.00	.00	.00	.00	.00	.00	.00
09/29/03	17:00	.00	.00	.00	.00	.00	.00	.00	.00	.00	.00
09/29/03	18:00	.00	.00	.00	.00	.00	.00	.00	.00	.00	.00
09/29/03	19:00	.00	.00	.00	.00	.00	.00	.00	.00	.00	.00
09/29/03	20:00	.00	.00	.00	.00	.00	.00	.00	.00	.00	.00
09/29/03	21:00	.00	.00	.00	.00	.00	.00	.00	.00	.00	.00
09/29/03	22:00	.00	.00	.00	.00	.00	.00	.00	.00	.00	.00
09/29/03	23:00	.00	.00	.00	.00	.00	.00	.00	.00	.00	.00

Max : .00  
 Min : .00  
 Mean : .00  
 Records : 240

Status : '<' - Less than ## Data, 'P' - Power Fail, 'D' - Disabled, 'T' - Out-of-Control, 'F' - Boiler Off-Line,  
 Flags : 'B' - Bad Status, 'C' - Calibration, 'M' - Maintenance, 'O' - Analog Overrange, 'U' - Analog Underrange,  
 'A' - Arithmetic Error, '+' - Maximum, '-' - Minimum, 'R' - Rate of Change, 'H' - High-High Alarm,  
 'L' - Low-Low Alarm, 'h' - High Alarm, 'l' - Low Alarm, 'J' - High Rate of Change, 'j' - Low Rate of Change,  
 'v' - DIS #1 Obs, 'W' - DIS #2 Obs, 'X' - DIS #3 Obs, 'Y' - DIS #4 Obs, 'Z' - DIS #5 Obs.

Current Date : 09/29/03  
 Current Time : 00:27

Daily Data Report - Hourly Averages  
 Wheelabrator Ridge Energy  
 09/28/03

Logger Id : 01

Logger Name : Ridge Energy

Interval : 001H

Param :	TIREFEED	O2WET	STKFLOW	MGWATTS	FTEMP	STMFLOW	CO#/HR	NO#/HR	SO2#/HR
Units :	KPPH	VOL%	KSCFM	MW	DEG_F	KPPH	#/HR	#/HR	#/HR
Stack :									
Unit :		Blr1	Blr1	Blr1	Blr1	Blr1	Blr1	Blr1	Blr1
Hour									
00	-1	11.4	182	17.8	2292	148.4	125.16	93.72	2.24
01	-1	11.3	174	16.4	2273	137.4	104.63	90.05	2.39
02	-1	12.0	188	16.8	2328	138.2	238.82	100.54	4.69
03	-1	10.6	176	18.8	2318	155.0	78.58	92.80	5.05
04	-1	10.6	183	21.1	2321	168.5	46.75	106.28	4.53
05	-1	11.1	182	18.6	2316	154.2	83.34	101.84	2.19
06	-1	11.1	182	17.5	2318	150.9	78.02	101.18	1.80
07	-1	11.5	187	17.5	2309	148.5	109.93	101.12	2.29
08	-1	11.7	184	17.3	2303	148.5	104.54	98.37	2.44
09	-1	11.6	180C	16.5	2307	141.8	108.44C	91.27C	2.14C
10	3.6	9.0C	195	27.0	2296	219.3	63.20C	130.29C	27.67C
11	18.5	7.6	209	43.1	2268	338.4	105.05	133.91	91.24
12	23.5	8.1	216	43.9	2288	342.1	113.60	138.52	117.79
13	23.2	7.9	214	43.2	2279	337.2	89.40	147.89	119.41
14	22.1	7.4C	222	44.5	2295	347.2	76.83C	160.43C	129.62C
15	22.2	7.1	217	44.4	2283	346.0	60.41	155.48	104.66
16	23.2	7.1	218	45.0	2289	350.2	70.50	162.62	105.39
17	23.8	6.8	216	44.8	2280	349.0	49.73	165.85	87.73
18	23.3	7.4	219	43.9	2292	342.0	67.92	170.42	96.65
19	21.9	7.2	221	44.8	2313	348.6	74.94	163.11	207.64
20	23.9	7.4	224	44.6	2336	348.0	70.89	170.81	126.90
21	23.0	7.9	224	43.2	2335	337.1	76.46	163.99	116.44
22	15.1	11.2C	195	19.6	2335	164.7	189.99C	107.00C	7.37C
23	-1	12.1	187	15.6	2336	135.0	358.58	108.82	8.48
Max :	23.9	12.1	224	45.0	2336	350.2	358.58	170.81	207.64
Min :	-1	6.8	174	15.6	2268	135.0	46.75	90.05	1.80
Avg :	11.1	9.5	200	30.2	2305	241.5	106.07	127.35	57.36
Hours :	24	24	24	24	24	24	24	24	24

Status : '<' - Less than ## Data, 'P' - Power Fail, 'D' - Disabled, 'T' - Out-of-Control, 'F' - Boiler Off-Line,  
 Tags : 'B' - Bed Status, 'C' - Calibration, 'M' - Maintenance, 'O' - Analog Overrange, 'U' - Analog Underrange,  
 'A' - Arithmetic Error, '+' - Maximum, '-' - Minimum, 'R' - Rate of Change, 'H' - High-High Alarm,  
 'L' - Low-Low Alarm, 'h' - High Alarm, 'l' - Low Alarm, 'J' - High Rate of Change, 'j' - Low Rate of Change,  
 'V' - DIS #1 Obs, 'W' - DIS #2 Obs, 'X' - DIS #3 Obs, 'Y' - DIS #4 Obs, 'Z' - DIS #5 Obs.



Current Date : 09/29/03  
 Current Time : 00:35

Daily Parameter Report - Auxiliary Averages  
 Wheelabrator Ridge Energy  
 09/28/03

Logger Name : RIDGE  
 Logger Id : 01

Stack :  
 Boiler/Unit : Opac

Parameter : STAKOPAC  
 Units : PERCENT

Date	Time	Minute										
		006M	00	06	12	18	24	30	36	42	48	54
09/28/03	00:00	.00	.00	.00	.00	.00	.00	.00	.00	.00	.00	.00
09/28/03	01:00	.00	.00	.00	.00	.00	.00	.00	.00	.00	.00	.00
09/28/03	02:00	.00	.00	.00	.00	.00	.00	.00	.00	.00	.00	.00
09/28/03	03:00	.00	.00	.00	.00	.00	.00	.00	.00	.00	.00	.00
09/28/03	04:00	.00	.00	.00	.00	.00	.00	.00	.00	.00	.00	.00
09/28/03	05:00	.00	.00	.00	.00	.00	.00	.00	.00	.00	.00	.00
09/28/03	06:00	.00	.00	.00	.00	.00	.00	.00	.00	.00	.00	.00
09/28/03	07:00	.00	.00	.00	.00	.00	.00	.00	.00	.00	.00	.00
09/28/03	08:00	.00	.00	.00	.00	.00	.00	.00	.00	.00	.00	.00
09/28/03	09:00	.00	.00	.00B	.00B	.00	.00	.00	.00	.00	.00	.00
09/28/03	10:00	.00	.00	.00	.00	.00	.00	.00	.00	.00	.00	.00
09/28/03	11:00	.00	.00	.00	.00	.00	.00	.00	.00	.00	.00	.00
09/28/03	12:00	.00	.00	.00	.00	.00	.00	.00	.00	.00	.00	.00
09/28/03	13:00	.00	.00	.00	.00	.00	.00	.00	.00	.00	.00	.00
09/28/03	14:00	.00	.00	.00	.00	.00	.00	.00	.00	.00	.00	.00
09/28/03	15:00	.00	.00	.00	.00	.00	.00	.00	.00	.00	.00	.00
09/28/03	16:00	.00	.00	.00	.00	.00	.00	.00	.00	.00	.00	.00
09/28/03	17:00	.00	.00	.00	.00	.00	.00	.00	.00	.00	.00	.00
09/28/03	18:00	.00	.00	.00	.00	.00	.00	.00	.00	.00	.00	.00
09/28/03	19:00	.00	.00	.00	.00	.00	.00	.04	.00	.00	.00	.00
09/28/03	20:00	.00	.02	.00	.00	.03	.00	.00	.00	.02	.00	.00
09/28/03	21:00	.05	.01	.00	.03	.00	.01	.00	.06	.02	.00	.00
09/28/03	22:00	.00	.00	.00	.00	.00	.00	.00	.00	.00	.00	.00
09/28/03	23:00	.00	.00	.00	.00	.00	.00	.00	.00	.00	.00	.00

Max .06  
 Min .00  
 Mean .00

Records : 240

Status : '<' - Less than ## Data, 'P' - Power Fail, 'D' - Disabled, 'T' - Out-of-Control, 'F' - Boiler Off-Line.  
 Flags : 'B' - Bad Status, 'C' - Calibration, 'M' - Maintenance, 'O' - Analog Overrange, 'U' - Analog Underrange,  
 'A' - Arithmetic Error, '+' - Maximum, '-' - Minimum, 'R' - Rate of Change, 'H' - High-High Alarm,  
 'L' - Low-Low Alarm, 'h' - High Alarm, 'l' - Low Alarm, 'J' - High Rate of Change, 'j' - Low Rate of Change,  
 'V' - DIS #1 Obs, 'W' - DIS #2 Obs, 'X' - DIS #3 Obs, 'Y' - DIS #4 Obs, 'Z' - DIS #5 Obs.

Current Date : 09/28/03  
 Current Time : 00:27

Daily Data Report - Hourly Averages  
 Wheelabrator Ridge Energy  
 09/27/03

Logger Id : 01

Logger Name : Ridge Energy

Interval : 001H

Param :	TIREFEED	O2WET	STKFLOW	MGWATTS	FTEMP	STMFLOW	CO#/HR	NO#/HR	SO2#/HR
Units :	KPPH	VOL%	KSCFM	MW	DEG_F	KPPH	#/HR	#/HR	#/HR
Stack :									
Unit :	Blr1	Blr1	Blr1	Blr1	Blr1	Blr1	Blr1	Blr1	Blr1
Hour :									
00	12.0	18.7	139	.0	835	.0	31.13	11.41	.00
01	.2	16.1	187	.0	1070	.0	533.48	67.51	.00
02	-.1	16.6	163	.0	1860	3.3	544.25	60.27	.00
03	-.1	15.6	146	4.9	2129	47.6	403.18	51.15	.28
04	-.1	16.6	131	6.5	2169	53.8	161.66	45.23	.26
05	-.1	18.2	122	.0	1667	.8	227.44	22.66	.00
06	-.1	15.6	122	3.3	1984	32.7	380.25	39.69	.20
07	-.1	12.0	110	10.3	2199	92.2	135.24	47.37	.09
08	-.1	11.8	143	15.0	2253	123.8	72.68	73.10	.05
09	-.1	17.1	102C	.7	2108	11.2	269.16C	22.32C	.01C
10	4.6	10.9C	179	24.3	2223	202.8	122.71C	122.85C	95.63C
11	15.6	9.4	228	42.7	2295	336.9	113.11	161.33	197.82
12	23.0	9.4	229	44.5	2295	348.7	102.84	160.54	137.03
13	24.2	8.6	216	44.8	2279	351.8	85.64	144.27	124.37
14	27.3	9.2	196	36.1	2202	287.6	131.42	109.01	159.65
15	25.3	9.8	227	41.7	2272	333.6	166.67	123.06	268.87
16	22.9	13.6B	141	15.3	2094	126.2	239.82B	52.31B	62.13B
17	11.9	8.6	210	37.4	2217	306.4	75.71	130.05	146.08
18	21.6	8.9	214	44.0	2263	342.6	77.53	116.75	121.17
19	17.9	9.6	244	44.9	2302	348.1	86.30	144.18	31.35
20	18.0	8.6	232	45.0	2308	349.2	72.81	149.81	56.27
21	17.6	8.1	221	44.5	2278	347.6	53.52	142.05	76.90
22	8.9	10.3C	177	22.3	2290	180.1	40.02C	84.25C	2.00C
23	-.1	11.3	176	17.5	2297	145.3	101.52	95.33	1.57
Max :	27.3	18.7	244	45.0	2308	351.8	544.25	161.33	268.87
Min :	-.1	8.1	102	.0	835	.0	31.13	11.41	.00
Mean :	10.4	12.3	177	22.7	2079	182.2	176.17	90.69	61.74
Hours :	24	24	24	24	24	24	24	24	24

Status : '<' - Less than ## Data, 'P' - Power Fail, 'D' - Disabled, 'T' - Out-of-Control, 'F' - Boiler Off-Line,  
 'B' - Bad Status, 'C' - Calibration, 'M' - Maintenance, 'O' - Analog Overrange, 'U' - Analog Underrange,  
 'A' - Arithmetic Error, 'x' - Maximum, 'm' - Minimum, 'R' - Rate of Change, 'H' - High-High Alarm,  
 'L' - Low-Low Alarm, 'h' - High Alarm, 'l' - Low Alarm, 'J' - High Rate of Change, 'j' - Low Rate of Change,  
 'V' - DIS #1 Obs., 'W' - DIS #2 Obs., 'X' - DIS #3 Obs., 'Y' - DIS #4 Obs., 'Z' - DIS #5 Obs.

Current Date : 09/28/03  
 Current Time : 00:35

Daily Parameter Report - Auxiliary Averages  
 Wheelabrator Ridge Energy  
 09/27/03

Logger Name : RIDGE  
 Logger Id : 01

Stack :  
 Boiler/Unit : Opac

Parameter : STAKOPAC  
 Units : PERCENT

Date	Time 006M	Minute										
		00	06	12	18	24	30	36	42	48	54	
09/27/03	00:00	.00	.00	.00	.00	.00	.00	.00	.00	.00	.00	.00
09/27/03	01:00	.00	.00	.00	.00	.00	.00	.00	.00	.00	.00	.00
09/27/03	02:00	.00	.00	.00	.00	.00	.00	.00	.00	.00	.00	.00
09/27/03	03:00	.00	.00	.00	.00	.00	.00	.00	.00	.00	.00	.00
09/27/03	04:00	.00	.00	.00	.00	.00	.00	.00	.00	.00	.00	.00
09/27/03	05:00	.00	.00	.00	.00	.00	.00	.00	.00	.00	.00	.00
09/27/03	06:00	.00	.00	.00	.00	.00	.00	.00	.00	.00	.00	.00
09/27/03	07:00	.00	.00	.00	.00	.00	.00	.00	.00	.00	.00	.00
09/27/03	08:00	.00	.00	.00	.00	.00	.00	.00	.00	.00	.00	.00
09/27/03	09:00	.00	.00	.00B	.00B	.00	.00	.00	.00	.00	.00	.00
09/27/03	10:00	.00	.00	.00	.00	.00	.00	.00	.00	.00	.00	.00
09/27/03	11:00	.00	.00	.00	.00	.00	.00	.00	.00	.00	.00	.00
09/27/03	12:00	.00	.00	.00	.00	.00	.00	.00	.00	.00	.00	.00
09/27/03	13:00	.00	.00	.00	.00	.00	.00	.00	.00	.00	.00	.00
09/27/03	14:00	.00	.00	.00	.00	.00	.00	.00	.00	.00	.00	.00
09/27/03	15:00	.00	.00	.00	.00	.00	.00	.00	.00	.00	.00	.00
09/27/03	16:00	.00	.00	.00	.00	.00	.00	.00	.00	.00	.00	.00
09/27/03	17:00	.00	.00	.00	.00	.00	.00	.00	.00	.00	.00	.00
09/27/03	18:00	.00	.00	.00	.00	.00	.00	.00	.00	.00	.00	.00
09/27/03	19:00	.00	.00	.00	.00	.00	.04	.00	.00	.00	.01	.00
09/27/03	20:00	.00	.00	.00	.01	.00	.00	.00	.00	.00	.00	.00
09/27/03	21:00	.00	.00	.00	.00	.00	.00	.00	.00	.00	.00	.00
09/27/03	22:00	.00	.00	.00	.00	.00	.00	.00	.00	.00	.00	.00
09/27/03	23:00	.00	.00	.00	.00	.00	.00	.00	.00	.00	.00	.00

Max .04  
 Min .00  
 Mean .00  
 Records 240

Status : 'C' - Less than 33% Data, 'P' - Power Fail, 'D' - Disabled, 'T' - Out-of-Control, 'F' - Boiler Off-Line,  
 Flags : 'B' - Bad Status, 'C' - Calibration, 'M' - Maintenance, 'O' - Analog Overrange, 'U' - Analog Underrange,  
 'A' - Arithmetic Error, 'H' - Maximum, 'L' - Minimum, 'R' - Rate of Change, 'H' - High-High Alarm,  
 'L' - Low-Low Alarm, 'h' - High Alarm, 'l' - Low Alarm, 'J' - High Rate of Change, 'j' - Low Rate of Change,  
 'V' - DIS #1 Obs, 'W' - DIS #2 Obs, 'X' - DIS #3 Obs, 'Y' - DIS #4 Obs, 'Z' - DIS #5 Obs

Current Date 09/20/03  
 Current Time 00:27

Daily Data Report - Hourly Averages  
 Wheelabrator Ridge Energy  
 09/19/03

Logger Id : 01

Logger Name : Ridge Energy

Interval : 001H

Param :	TIREFEED	O2WET	STKFLOW	MGWATTS	FTEMP	STMFLOW	CO#/HR	NO#/HR	SO2#/HR
Units :	KPPH	VOL%	KSCFM	MW	DEG_F	KPPH	#/HR	#/HR	#/HR
Stack :									
Jnit :		Blr1	Blr1	Blr1	Blr1	Blr1	Blr1	Blr1	Blr1
Hour									
00	.0	14.2	198	12.4	2316	104.2	230.25	64.29	17.83
01	.0	13.2	203	14.5	2336	121.1	114.66	68.68	14.11
02	.0	13.4	194	15.3	2336	127.4	58.46	64.44	8.47
03	.0	13.6	190	14.7	2319	126.3	71.07	64.22	4.38
04	.0	13.6	191	14.9	2321	124.2	61.72	66.57	3.99
05	.0	13.5	196	14.9	2335	124.8	55.78	71.17	6.44
06	.0	13.6C	192	14.6	2330	123.1	63.80C	67.59C	1.83C
07	.0	13.6	190	14.7	2331	124.7	82.03	64.65	.26
08	.0	11.5	224	27.5	2326	217.0	29.60	118.19	4.51
09	7.6	11.7	238C	30.1	2335	234.1	22.21C	120.19C	9.61C
10	13.6	11.8C	234	32.6	2303	255.9	23.94C	126.86C	104.03C
11	19.4	10.8	239	38.4	2274	302.9	183.53	110.66	128.53
12	26.5	10.5	242	40.1	2278	316.4	372.51	97.44	162.38
13	24.1	10.8	242	40.8	2261	323.2	257.87	116.48	128.49
14	27.2	10.8	239	40.6	2248	323.9	205.10	113.39	107.67
15	28.4	10.9	237	38.5	2253	306.8	211.13	110.57	45.71
16	25.1	10.4	239	40.3	2263	319.7	347.90	107.08	115.89
17	24.6	11.2	240	37.0	2270	293.2	140.60	115.46	55.53
18	23.2	10.7	243	38.7	2278	305.1	401.71	109.35	23.55
19	20.3	10.1	240	38.0	2287	296.6	395.95	97.90	65.19
20	28.0	10.7	241	38.9	2267	305.0	468.86	105.56	158.62
21	17.0	10.5	245	40.5	2275	319.4	423.01	113.53	93.98
22	5.7	18.4C	235	12.8	2061	95.8	295.45C	27.76C	4.17C
23	-.1	20.2	128	.0	1090	.0	22.23	4.91	1.41
Max :	28.4	20.2	245	40.8	2336	323.9	468.86	126.86	162.38
Min :	-.1	10.1	128	.0	1090	.0	22.21	4.91	.26
Aean :	12.1	12.5	219	27.1	2237	216.3	189.14	88.62	52.77
Hours :	24	24	24	24	24	24	24	24	24

Status : '<' - Less than ## Data, 'P' - Power Fail, 'D' - Disabled, 'T' - Out-of-Control, 'F' - Boiler Off-Line,  
 Lags : 'B' - Bad Status, 'C' - Calibration, 'M' - Maintenance, 'O' - Analog Overrange, 'U' - Analog Underrange,  
 'A' - Arithmetic Error, '+' - Maximum, '-' - Minimum, 'R' - Rate of Change, 'H' - High-High Alarm,  
 'L' - Low-Low Alarm, 'h' - High Alarm, 'l' - Low Alarm, 'J' - High Rate of Change, 'j' - Low Rate of Change,  
 'V' - DIS #1 Obs, 'W' - DIS #2 Obs, 'X' - DIS #3 Obs, 'Y' - DIS #4 Obs, 'Z' - DIS #5 Obs

Current Date 09/20/03  
 Current Time 00:35

Daily Parameter Report - Auxiliary Averages  
 Wheelabrator Ridge Energy  
 09/19/03

Logger Name : RIDGE  
 Logger Id : 01

Stack :  
 Boiler/Unit : Opac

Parameter : STAKOPAC  
 Units : PERCENT

Date	Time	00	06	12	18	24	Minute	30	36	42	48	54
09/19/03	00:00	.00	.00	.00	.00	.00	.00	.00	.00	.00	.00	.00
09/19/03	01:00	.00	.00	.00	.00	.00	.00	.00	.00	.00	.00	.00
09/19/03	02:00	.00	.00	.00	.00	.00	.00	.00	.00	.00	.00	.00
09/19/03	03:00	.00	.00	.00	.00	.00	.00	.00	.00	.00	.00	.00
09/19/03	04:00	.00	.00	.00	.00	.00	.00	.00	.00	.00	.00	.00
09/19/03	05:00	.00	.00	.00	.00	.00	.00	.00	.00	.00	.00	.00
09/19/03	06:00	.00	.00	.00	.00	.00	.00	.00	.00	.00	.00	.00
09/19/03	07:00	.00	.00	.00	.00	.00	.00	.00	.00	.00	.00	.00
09/19/03	08:00	.00	.00	.00	.00	.00	.00	.00	.00	.00	.00	.00
09/19/03	09:00	.00	.00	.00B	.00B	.00	.00	.00	.00	.00	.00	.00
09/19/03	10:00	.00	.00	.00	.00	.00	.00	.00	.00	.00	.00	.00
09/19/03	11:00	.00	.00	.00	.00	.00	.00	.00	.00	.00	.00	.00
09/19/03	12:00	.00	.00	.00	.00	.00	.00	.00	.00	.00	.00	.00
09/19/03	13:00	.00	.00	.00	.00	.00	.00	.00	.00	.00	.00	.00
09/19/03	14:00	.00	.00	.00	.00	.00	.00	.00	.00	.00	.00	.00
09/19/03	15:00	.00	.00	.00	.00	.00	.00	.00	.00	.00	.00	.00
09/19/03	16:00	.00	.00	.00	.00	.00	.00	.00	.00	.00	.00	.00
09/19/03	17:00	.00	.00	.00	.00	.00	.00	.00	.00	.00	.00	.00
09/19/03	18:00	.00	.00	.00	.00	.00	.00	.00	.00	.00	.00	.00
09/19/03	19:00	.00	.00	.00	.00	.00	.12	.00	.00	.00	.00	.00
09/19/03	20:00	.00	.00	.00	.00	.00	.00	.00	.00	.00	.00	.00
09/19/03	21:00	.00	.00	.00	.00	.00	.00	.00	.00	.00	.00	.00
09/19/03	22:00	.00	.00	.00	.00	.00	.00	.00	.00	.00	.00	.00
09/19/03	23:00	.00	.00	.00	.00	.00	.00	.00	.00	.00	.00	.00

Max .12  
 Min .00  
 Mean .00  
 Records 240

Status : '<' - Less than ### Data, 'P' - Power Fail, 'D' - Disabled, 'T' - Out-of-Control, 'F' - Boiler Off-Line,  
 Flags : 'B' - Bad Status, 'C' - Calibration, 'M' - Maintenance, 'O' - Analog Overrange, 'U' - Analog Underrange,  
 'A' - Arithmetic Error, '+' - Maximum, '-' - Minimum, 'R' - Rate of Change, 'H' - High-High Alarm,  
 'L' - Low-Low Alarm, 'h' - High Alarm, 'l' - Low Alarm, 'J' - High Rate of Change, 'j' - Low Rate of Change,  
 'V' - DIS #1 Obs, 'W' - DIS #2 Obs, 'X' - DIS #3 Obs, 'Y' - DIS #4 Obs, 'Z' - DIS #5 Obs.

Current Date: 09/18/03  
 Current Time: 00:27

Daily Data Report - Hourly Averages  
 Wheelabrator Ridge Energy  
 09/17/03

Logger Id : 01

Logger Name : Ridge Energy

Interval : 001H

Param :	TIREFEED	O2WET	STKFLOW	MGWATTS	FTEMP	STMFLOW	CO#/HR	NO#/HR	SO2#/HR
Units :	KPPH	VOL%	KSCFM	MW	DEG F	KPPH	#/HR	#/HR	#/HR
Stack :									
Unit :		Blr1	Blr1	Blr1	Blr1	Blr1	Blr1	Blr1	Blr1
Hour :									
00	.0	12.9	164	12.5	2326	113.1	11.77	55.19	7.27
01	.0	13.1	168	12.9	2335	115.6	14.11	56.99	2.63
02	.0	13.2	169	12.7	2336	113.8	19.83	55.32	1.57
03	.0	13.3	169	12.6	2337	113.1	17.82	56.21	1.63
04	.0	13.5	176	12.7	2336	115.0	25.09	56.19	1.85
05	.0	13.5	175	12.8	2336	114.9	24.86	54.93	.99
06	.0	13.2	176	12.8	2335	114.7	13.40	56.53	1.78
07	.0	13.4	188	12.7	2336	111.2	38.86	61.04	8.97
08	.0	14.5	231	13.8	2337	118.7	127.29	85.53	18.87
09	.0	13.4	184C	14.4	2336	124.3	30.02C	66.44C	3.87C
10	2.3	13.8C	233	19.9	2333	164.0	54.83C	93.16C	20.58C
11	14.0	11.0	248	37.9	2283	297.6	478.34	101.95	93.12
12	26.4	12.4	245	30.2	2292	240.6	228.50	104.83	123.27
13	15.7	11.5	247	36.6	2250	290.7	169.43	111.14	148.11
14	22.9	11.4	248	36.8	2257	290.6	394.62	103.42	108.42
15	20.6	11.1	247	38.3	2246	303.0	269.80	104.41	96.27
16	24.1	11.1	246	38.5	2235	306.1	225.99	114.56	122.35
17	26.1	10.9	246	39.6	2239	314.0	411.49	105.32	114.15
18	25.6	11.0	244	38.9	2221	310.0	227.85	103.92	130.68
19	26.6	10.6	247	40.0	2243	315.7	439.84	97.29	108.17
20	25.8	10.9	246	39.4	2245	310.0	307.75	102.11	73.16
21	24.0	10.9	244	40.5	2254	315.4	260.59	119.30	76.77
22	16.5	19.5C	236	6.2	1783	48.6	37.31C	10.40C	2.68C
23	.4	20.5	243	.0	944	.0	3.07	6.20	2.07
Max :	26.6	20.5	248	40.5	2337	315.7	478.34	119.30	148.11
Min :	.0	10.6	164	.0	944	.0	3.07	6.20	.99
Mean :	11.3	12.9	218	23.9	2216	194.2	159.69	78.43	52.88
Hours :	24	24	24	24	24	24	24	24	24

Status :  
 Flags :  
 'C' - Less than ## Data,  
 'B' - Bad Status,  
 'A' - Arithmetic Error,  
 'L' - Low-Low Alarm,  
 'X' - DIS #1 Obs,  
 'P' - Power Fail,  
 'C' - Calibration,  
 '+' - Maximum,  
 'h' - High Alarm,  
 'W' - DIS #2 Obs,  
 'D' - Disabled,  
 'M' - Maintenance,  
 '-' - Minimum,  
 'l' - Low Alarm,  
 'X' - DIS #3 Obs,  
 'O' - Analog Overrange,  
 'R' - Rate of Change,  
 'J' - High Rate of Change,  
 'Y' - DIS #4 Obs,  
 'F' - Boiler Off-Line,  
 'U' - Analog Underrange,  
 'H' - High-High Alarm,  
 'J' - Low Rate of Change,  
 'Z' - DIS #5 Obs

Current Date 09/18/03  
 Current Time 00:35

Daily Parameter Report - Auxiliary Averages  
 Wheelabrator Ridge Energy  
 09/17/03

Logger Name : RIDGE  
 Logger Id : 01

Stack :  
 Boiler/Unit : Opac

Parameter : STAKOPAC  
 Units : PERCENT

Date	Time 006M	Minute									
		00	06	12	18	24	30	36	42	48	54
09/17/03	00:00	.00	.00	.00	.00	.00	.00	.00	.00	.00	.00
09/17/03	01:00	.00	.00	.00	.00	.00	.00	.00	.00	.00	.00
09/17/03	02:00	.00	.00	.00	.00	.00	.00	.00	.00	.00	.00
09/17/03	03:00	.00	.00	.00	.00	.00	.00	.00	.00	.00	.00
09/17/03	04:00	.00	.00	.00	.00	.00	.00	.00	.00	.00	.00
09/17/03	05:00	.00	.00	.00	.00	.00	.00	.00	.00	.00	.00
09/17/03	06:00	.00	.00	.00	.00	.00	.00	.00	.00	.00	.00
09/17/03	07:00	.00	.00	.00	.00	.00	.00	.00	.00	.00	.00
09/17/03	08:00	.00	.00	.00	.00	.00	.00	.00	.00	.00	.00
09/17/03	09:00	.00	.00	.00B	.00B	.00	.00	.00	.00	.00	.00
09/17/03	10:00	.00	.00	.00	.00	.00	.00	.00	.00	.00	.00
09/17/03	11:00	.00	.00	.00	.00	.00	.00	.00	.00	.00	.00
09/17/03	12:00	.00	.00	.00	.00	.00	.00	.00	.00	.00	.00
09/17/03	13:00	.00	.00	.00	.00	.00	.00	.00	.00	.00	.00
09/17/03	14:00	.00	.00	.00	.00	.00	.00	.00	.00	.00	.00
09/17/03	15:00	.00	.00	.00	.00	.00	.00	.00	.00	.00	.00
09/17/03	16:00	.00	.00	.00	.00	.00	.00	.00	.00	.00	.00
09/17/03	17:00	.00	.00	.00	.00	.00	.00	.00	.00	.00	.00
09/17/03	18:00	.00	.00	.00	.00	.00	.00	.00	.00	.00	.00
09/17/03	19:00	.00	.00	.00	.00	.00	.00	.00	.00	.00	.00
09/17/03	20:00	.00	.00	.00	.00	.00	.00	.00	.00	.00	.00
09/17/03	21:00	.00	.00	.00	.00	.00	.00	.00	.00	.00	.00
09/17/03	22:00	.00	.00	.00	.00	.00	.00	.00	.00	.00	.00
09/17/03	23:00	.00	.00	.00	.00	.00	.00	.00	.00	.00	.00

Max .00  
 Min .00  
 Mean .00  
 Records 240

Status : 'L' - Less than ## Data, 'P' - Power Fail, 'D' - Disabled, 'T' - Out-of-Control, 'F' - Boiler Off-Line,  
 Flags : 'B' - Bad Status, 'C' - Calibration, 'M' - Maintenance, 'O' - Analog Overrange, 'U' - Analog Underrange,  
 'A' - Arithmetic Error, '+' - Maximum, '-' - Minimum, 'R' - Rate of Change, 'H' - High-High Alarm,  
 'L' - Low-Low Alarm, 'h' - High Alarm, 'l' - Low Alarm, 'J' - High Rate of Change, 'j' - Low Rate of Change,  
 'V' - DIS #1 Obs, 'W' - DIS #2 Obs, 'X' - DIS #3 Obs, 'Y' - DIS #4 Obs, 'Z' - DIS #5 Obs.

Current Date : 09/17/03  
 Current Time : 00:27

Cur:  
 Cur:

Daily Data Report - Hourly Averages  
 Wheelabrator Ridge Energy  
 09/16/03

Logger Id : 01

Logger Name : Ridge Energy

Interval : 001H

Param :	TIREFEED	O2WET	STRFLOW	MGWATTS	FTEMP	STMFLOW	CO#/HR	NO#/HR	SO2#/HR	Date
Units :	KPPH	VOL%	KSCFM	MW	DEG_F	KPPH	#/HR	#/HR	#/HR	
Stack :										
Unit :	Blr1	Blr1	Blr1	Blr1	Blr1	Blr1	Blr1	Blr1	Blr1	
hour										
00	.0	12.4	156	13.2	2297	116.7	7.73	54.05	3.50	09/16
01	.0	12.6	156	12.7	2298	112.7	10.68	50.95	1.69	09/16
02	.0	12.6	157	13.1	2294	115.5	5.94	52.77	.99	09/16
03	.0	12.9	160	12.9	2293	114.2	9.70	53.98	.16	09/16
04	.0	12.7	158	13.0	2312	115.0	10.64	54.27	.15	09/16
05	.0	12.4	153	12.8	2314	114.1	9.06	53.18	.59	09/16
06	.0	12.7	165	12.8	2332	113.7	11.44	54.83	1.18	09/16
07	.0	12.8	174	13.5	2330	117.9	33.64	52.29	6.49	09/16
08	.0	14.1	222	15.0	2336	128.4	95.83	74.32	20.54	09/16
09	.0	12.7	183C	15.9	2336	134.7	18.66C	61.21C	8.81C	09/16
10	2.1	11.6C	233	28.4	2328	228.7	241.75C	109.37C	16.77C	09/16
11	21.1	10.9	248	40.0	2252	321.2	415.62	107.52	133.62	09/16
12	25.0	11.2	248	39.8	2249	318.1	258.77	117.33	158.10	09/16
13	28.9	11.3	247	39.0	2260	310.8	194.18	118.47	157.54	09/16
14	29.8	11.2	247	39.8	2244	318.0	183.22	118.15	164.57	09/16
15	30.2	11.0	247	39.9	2250	318.4	464.64	111.21	177.73	09/16
16	32.0	10.5	243	40.9	2237	325.8	677.74	100.24	201.15	09/16
17	27.1	10.9	243	39.8	2239	318.2	429.32	110.46	150.89	09/16
18	25.4	11.0	244	39.5	2237	314.7	218.96	118.99	117.65	09/16
19	23.3	10.9	245	39.6	2264	313.2	289.59	112.51	114.89	09/16
20	27.1	10.9	247	39.3	2262	309.0	396.71	111.21	79.70	09/16
21	22.9	11.1	247	38.5	2275	302.8	333.58	110.08	41.26	09/16
22	15.7	13.4C	192	17.3	2332	146.2	69.07C	65.24C	5.19C	09/16
23	.4	12.9	166	12.7	2336	114.9	13.93	58.76	14.30	09/16
Max :	32.0	14.1	248	40.9	2336	325.8	677.74	118.99	201.15	
Min :	.0	10.5	153	12.7	2237	112.7	5.94	50.95	.15	
Mean :	13.0	11.9	208	26.2	2288	214.3	183.35	84.64	65.73	Status :
Hours :	24	24	24	24	24	24	24	24	24	Flags :

Status : 'L' - Less than ## Data, 'P' - Power Fail, 'D' - Disabled, 'T' - Out-of-Control, 'F' - Boiler Off-Line,  
 'B' - Bad Status, 'C' - Calibration, 'M' - Maintenance, 'O' - Analog Overrange, 'U' - Analog Under-range,  
 'A' - Arithmetic Error, '+' - Maximum, '-' - Minimum, 'R' - Rate of Change, 'H' - High-High Alarm,  
 'L' - Low-Low Alarm, 'h' - High Alarm, 'l' - Low Alarm, 'J' - High Rate of Change, 'j' - Low Rate of Change,  
 'V' - DIS #1 Obs, 'W' - DIS #2 Obs, 'X' - DIS #3 Obs, 'Y' - DIS #4 Obs, 'Z' - DIS #5 Obs.



ent Date : 09/17/03  
ent Time : 00:35

Daily Parameter Report - Auxiliary Averages  
Wheelabrator Ridge Energy  
09/16/03

Logger Name : RIDGE  
Logger Id : 01

Stack :  
Boiler/Unit : Opac

Parameter : STAKOPAC  
Units : PERCENT

Time	00	06	12	18	24	30	36	42	48	54
/03 00:00	.00	.00	.00	.00	.00	.00	.00	.00	.00	.00
/03 01:00	.00	.00	.00	.00	.00	.00	.00	.00	.00	.00
/03 02:00	.00	.00	.00	.00	.00	.00	.00	.00	.00	.00
/03 03:00	.00	.00	.00	.00	.00	.00	.00	.00	.00	.00
/03 04:00	.00	.00	.00	.00	.00	.00	.00	.00	.00	.00
/03 05:00	.00	.00	.00	.00	.00	.00	.00	.00	.00	.00
/03 06:00	.00	.00	.00	.00	.00	.00	.00	.00	.00	.00
/03 07:00	.00	.00	.00	.00	.00	.00	.00	.00	.00	.00
/03 08:00	.00	.00	.00	.00	.00	.00	.00	.00	.00	.00
/03 09:00	.00	.00	.00B	.00B	.00	.00	.00	.00	.00	.00
/03 10:00	.00	.00	.00	.00	.00	.00	.00	.00	.00	.00
/03 11:00	.00	.00	.00	.00	.00	.00	.00	.00	.00	.00
/03 12:00	.00	.00	.00	.00	.00	.00	.00	.00	.00	.00
/03 13:00	.00	.00	.00	.00	.00	.00	.00	.00	.00	.00
/03 14:00	.00	.00	.00	.00	.00	.00	.00	.00	.00	.00
/03 15:00	.00	.00	.00	.00	.00	.00	.00	.00	.00	.00
/03 16:00	.00	.00	.00	.00	.00	.00	.00	.00	.00	.00
/03 17:00	.00	.00	.00	.00	.00	.00	.00	.00	.00	.00
/03 18:00	.00	.00	.00	.00	.00	.00	.00	.00	.00	.00
/03 19:00	.00	.00	.00	.00	.00	.00	.00	.00	.00	.00
/03 20:00	.00	.00	.00	.00	.00	.00	.00	.00	.00	.00
/03 21:00	.00	.00	.00	.00	.00	.00	.00	.00	.00	.00
/03 22:00	.00	.00	.00	.00	.00	.00	.00	.00	.00	.00
/03 23:00	.00	.00	.00	.00	.00	.00	.00	.00	.00	.00

Max .00  
Min .00  
Mean .00

Records 240

'K' - Less than ## Data, 'P' - Power Fail, 'D' - Disabled, 'T' - Out-of-Control, 'F' - Boiler Off-Line,  
'B' - Bad Status, 'C' - Calibration, 'M' - Maintenance, 'O' - Analog Overrange, 'U' - Analog Underrange,  
'A' - Arithmetic Error, '+' - Maximum, '-' - Minimum, 'R' - Rate of Change, 'H' - High-High Alarm,  
'L' - Low-Low Alarm, 'h' - High Alarm, 'l' - Low Alarm, 'J' - High Rate of Change, 'j' - Low Rate of Change,  
'V' - DIS #1 Obs, 'W' - DIS #2 Obs, 'X' - DIS #3 Obs, 'Y' - DIS #4 Obs, 'Z' - DIS #5 Obs.

Current Date: 09/16/03  
 Current Time: 00:27

Daily Data Report - Hourly Averages  
 Wheelabrator Ridge Energy  
 09/15/03

Logger Id : 01

Logger Name : Ridge Energy

Interval : 001H

Param :	TIREFEED	O2WET	STKFLOW	MGWATTS	FTEMP	STMFLOW	CO#/HR	NO#/HR	SO2#/HR
Units :	KPPH	VOL%	KSCFM	MW	DEG_F	KPPH	#/HR	#/HR	#/HR
Stack :									
Jnit :		Blr1	Blr1	Blr1	Blr1	Blr1	Blr1	Blr1	Blr1
Hour :									
00	.0	12.9	178	14.8	2333	123.3	11.72	60.98	8.64
01	.0	13.3	176	13.3	2325	114.5	13.70	58.18	5.07
02	.0	13.0	173	13.6	2318	118.4	11.68	59.47	6.72
03	.0	13.2	171	13.0	2311	114.5	15.07	60.89	3.93
04	.0	13.4	179	13.6	2321	115.1	14.06	64.54	5.72
05	.0	12.9	178	14.2	2336	118.8	10.73	60.80	8.84
06	.0	13.0	180	13.5	2336	113.8	11.19	58.92	10.51
07	.0	13.5	201	13.8	2336	114.2	47.38	63.77	16.44
08	.0	14.3	220	13.4	2336	112.1	86.10	72.97	16.19
09	.0	14.1	214C	15.3	2336	127.8	89.11C	75.08C	8.57C
10	2.4	11.6C	229	28.7	2330	222.9	433.89C	87.15C	11.72C
11	20.3	11.5	247	37.0	2264	287.2	462.48	100.85	86.90
12	23.8	10.8	250	40.0	2262	310.1	477.56	102.55	78.03
13	22.9	11.0	249	40.6	2249	318.7	260.51	112.37	94.03
14	23.1	10.8	248	40.5	2249	318.2	401.15	106.43	104.98
15	23.8	10.9	247	39.8	2265	312.2	326.02	104.94	64.56
16	25.2	10.7	246	40.0	2249	313.4	601.31	99.46	96.70
17	23.6	10.9	246	39.7	2257	311.3	421.40	104.05	79.62
18	20.0	10.6	245	40.9	2248	320.2	426.01	99.43	181.28
19	25.5	10.4	241	39.4	2252	306.8	413.01	91.92	189.16
20	30.9	10.9	242	39.7	2238	311.5	400.94	101.52	176.65
21	25.0	11.0	243	40.8	2262	319.7	217.50	109.08	200.17
22	22.8	13.2C	190	18.1	2325	151.9	26.90C	61.54C	7.70C
23	1.1	12.7	162	13.0	2318	114.4	10.23	55.23	9.47
Max :	30.9	14.3	250	40.9	2336	320.2	601.31	112.37	200.17
Min :	.0	10.4	162	13.0	2238	112.1	10.23	55.23	3.93
Mean :	12.1	12.1	215	26.5	2294	212.1	216.24	82.17	61.32
Hours :	24	24	24	24	24	24	24	24	24

Status : '<' - Less than 10% Data, 'P' - Power Fail, 'D' - Disabled, 'T' - Out-of-Control, 'F' - Boiler Off-Line,  
 Lags : 'B' - Bad Status, 'C' - Calibration, 'M' - Maintenance, 'O' - Analog Overrange, 'U' - Analog Underrange,  
 'A' - Arithmetic Error, 'X' - Maximum, 'N' - Minimum, 'R' - Rate of Change, 'H' - High-High Alarm,  
 'L' - Low-Low Alarm, 'H' - High Alarm, 'L' - Low Alarm, 'U' - High Rate of Change, 'J' - Low Rate of Change,  
 'V' - DIS #1 Obs, 'W' - DIS #2 Obs, 'X' - DIS #3 Obs, 'Y' - DIS #4 Obs, 'Z' - DIS #5 Obs

Current Date 09/16/03  
 Current Time 00:35

Daily Parameter Report - Auxiliary Averages  
 Wheelabrator Ridge Energy  
 09/15/03

Logger Name : RIDGE  
 Logger Id : 01

Stack :  
 Boiler/Unit : Opac

Parameter : STAKOPAC  
 Units : PERCENT

Date	Time 006M	Minute										
		00	06	12	18	24	30	36	42	48	54	
09/15/03	00:00	.00	.00	.00	.00	.00	.00	.00	.00	.00	.00	.00
09/15/03	01:00	.00	.00	.00	.00	.00	.00	.00	.00	.00	.00	.00
09/15/03	02:00	.00	.00	.00	.00	.00	.00	.00	.00	.00	.00	.00
09/15/03	03:00	.00	.00	.00	.00	.00	.00	.00	.00	.00	.00	.00
09/15/03	04:00	.00	.00	.00	.00	.00	.00	.00	.00	.00	.00	.00
09/15/03	05:00	.00	.00	.00	.00	.00	.00	.00	.00	.00	.00	.00
09/15/03	06:00	.00	.00	.00	.00	.00	.00	.00	.00	.00	.00	.00
09/15/03	07:00	.00	.00	.00	.00	.00	.00	.00	.00	.00	.00	.00
09/15/03	08:00	.00	.00	.00	.00	.00	.00	.00	.00	.00	.00	.00
09/15/03	09:00	.00	.00	.00B	.00B	.00	.00	.00	.00	.00	.00	.00
09/15/03	10:00	.00	.00	.00	.00	.00	.00	.00	.00	.00	.00	.00
09/15/03	11:00	.00	.00	.00	.00	.00	.00	.00	.00	.00	.00	.00
09/15/03	12:00	.00	.00	.00	.00	.00	.00	.00	.00	.00	.00	.00
09/15/03	13:00	.00	.00	.00	.00	.00	.00	.00	.00	.00	.00	.00
09/15/03	14:00	.00	.00	.00	.00	.00	.00	.00	.00	.00	.00	.00
09/15/03	15:00	.00	.00	.00	.00	.00	.00	.00	.00	.00	.00	.00
09/15/03	16:00	.00	.00	.00	.00	.00	.00	.00	.00	.00	.00	.00
09/15/03	17:00	.00	.00	.00	.00	.00	.00	.00	.00	.00	.00	.00
09/15/03	18:00	.00	.00	.00	.00	.00	.00	.00	.00	.00	.00	.00
09/15/03	19:00	.00	.00	.00	.00	.00	.00	.02	.04	.00	.00	.02
09/15/03	20:00	.00	.00	.01	.00	.00	.00	.00	.00	.00	.00	.00
09/15/03	21:00	.00	.00	.00	.00	.00	.00	.00	.00	.00	.00	.00
09/15/03	22:00	.00	.00	.00	.00	.00	.00	.00	.00	.00	.00	.00
09/15/03	23:00	.00	.00	.00	.00	.00	.00	.00	.00	.00	.00	.00

Max .04  
 Min .00  
 Mean .00

Records: 240

Status : '<' - Less than ##% Data, 'P' - Power Fail, 'D' - Disabled, 'T' - Out-of-Control, 'F' - Boiler Off-Line,  
 Flag : 'B' - Bad Status, 'C' - Calibration, 'M' - Maintenance, 'O' - Analog Overrange, 'U' - Analog Underrange,  
 'A' - Arithmetic Error, 'X' - Maximum, 'I' - Minimum, 'R' - Rate of Change, 'H' - High-High Alarm,  
 'L' - Low-Low Alarm, 'h' - High Alarm, 'l' - Low Alarm, 'U' - High Rate of Change, 'J' - Low Rate of Change,  
 'V' - DIS #1 Obs, 'W' - DIS #2 Obs, 'X' - DIS #3 Obs, 'Y' - DIS #4 Obs, 'Z' - DIS #5 Obs

Current Date 9/15/03  
 Current Time 00:27

Daily Data Report - Hourly Averages  
 Wheelabrator Ridge Energy  
 09/14/03

Logger Id : 01

Logger Name : Ridge Energy

Interval : 001H

Param :	TIREFEED	O2WET	STKFLOW	MGWATTS	FTEMP	STMFLOW	CO#/HR	NO#/HR	SO2#/HR
Units :	KPPH	VOL%	KSCFM	MW	DEG_F	KPPH	#/HR	#/HR	#/HR
Unit :	Blr1	Blr1	Blr1	Blr1	Blr1	Blr1	Blr1	Blr1	Blr1
Hour :	-----								
00	.0	14.2	222	16.2	2336	127.7	40.03	80.14	5.31
01	.0	14.2	227	16.8	2337	135.0	40.65	83.75	4.06
02	.0	14.0	227	17.4	2336	139.5	37.05	85.82	3.14
03	.0	13.7	228	17.2	2336	138.8	36.16	82.00	4.21
04	.0	14.3	227	15.8	2336	129.1	70.27	76.83	4.26
05	.0	14.2	227	16.5	2336	134.0	68.78	76.99	4.45
06	.0	13.4	216	15.4	2336	126.3	86.61	67.92	2.84
07	4.4	12.4	197	17.2	2336	135.8	6.08	68.08	4.01
08	4.5	13.0	200	15.9	2336	129.6	32.79	63.29	3.81
09	.0	13.6	214C	16.2	2336	131.6	24.90C	66.90C	3.55C
10	1.9	12.0C	243	29.0	2330	225.1	114.12C	111.33C	24.32C
11	20.8	11.1	252	38.3	2279	299.4	352.97	109.25	79.15
12	26.9	11.0	251	41.5	2241	326.3	211.15	119.31	151.81
13	28.7	11.1	250	41.0	2241	322.5	173.62	117.39	157.26
14	30.4	11.0	250	41.3	2234	325.6	159.14	120.77	139.52
15	28.5	11.3	249	39.6	2249	310.6	98.29	123.62	107.49
16	26.9	11.0	249	40.2	2246	315.8	196.59	117.72	113.61
17	26.9	10.9	248	40.6	2242	319.4	282.85	114.18	124.44
18	26.5	10.4	246	40.7	2237	319.7	572.70	96.08	144.91
19	25.1	10.6	247	40.3	2256	315.3	432.60	105.52	122.53
20	26.7	10.8	248	40.2	2269	313.9	393.44	106.62	88.44
21	23.2	10.8	249	40.7	2279	317.6	483.66	100.54	40.73
22	19.3	13.6C	206	19.2	2333	155.9	46.01C	72.92C	11.36C
23	2.6	13.1	182	14.2	2336	120.4	13.29	61.24	17.77
Max :	30.4	14.3	252	41.5	2337	326.3	572.70	123.62	197.26
Min :	.0	10.4	182	14.2	2234	120.4	6.08	61.24	2.84
Mean :	13.5	12.3	231	28.0	2297	221.5	165.57	92.84	56.79
Hours :	24	24	24	24	24	24	24	24	24

Status : '<' - Less than ##% Data, 'P' - Power Fail, 'D' - Disabled, 'T' - Out-of-Control, 'F' - Boiler Off-Line,  
 Flags : 'B' - Bad Status, 'C' - Calibration, 'M' - Maintenance, 'O' - Analog Overrange, 'U' - Analog Underrange,  
 'A' - Arithmetic Error, '+M' - Maximum, 'Mn' - Minimum, 'R' - Rate of Change, 'H' - High-High Alarm,  
 'L' - Low-Low Alarm, 'H' - High Alarm, 'L' - Low Alarm, 'U' - High Rate of Change, 'J' - Low Rate of Change,  
 'V' - DIS #1 Obs, 'W' - DIS #2 Obs, 'X' - DIS #3 Obs, 'Y' - DIS #4 Obs, 'Z' - DIS #5 Obs



Current Date 09/14/03  
 Current Time 00:27

Daily Data Report - Hourly Averages  
 Wheelabrator Ridge Energy  
 09/13/03

Logger Id : 01

Logger Name : Ridge Energy

Interval : 001H

Param :	TIREFEED	O2WET	STKFLOW	MGWATTS	FTEMP	STMFLOW	CO#/HR	NO#/HR	SO2#/HR
Units :	KPPH	VOL%	KSCFM	MW	DEG_F	KPPH	#/HR	#/HR	#/HR
Stack :									
Unit :		Blr1	Blr1	Blr1	Blr1	Blr1	Blr1	Blr1	Blr1
Hour	-----								
00	7.4	13.9	222	14.5	2336	125.5	117.05	83.69	19.66
01	.0	13.6	219	14.7	2336	129.9	52.96	82.12	20.53
02	.0	14.1	219	13.0	2336	116.4	97.33	79.31	17.88
03	.0	13.5	230	16.3	2336	138.0	34.72	82.82	19.78
04	.0	13.7	229	15.3	2336	134.7	68.08	80.64	20.03
05	.0	14.0	228	14.4	2336	127.7	73.67	75.55	18.34
06	.0	13.6	221	14.9	2336	130.8	51.25	75.26	17.33
07	.0	12.9	209	15.7	2336	133.7	21.22	74.02	11.73
08	.1	13.3	210	15.8	2336	135.9	23.13	69.98	13.80
09	.0	13.0	208C	17.1	2337	135.1	10.29C	72.74C	27.09C
10	.6	10.7C	239	30.9	2320	237.7	34.73C	115.83C	.52C
11	12.1	11.1	251	40.1	2278	311.3	201.60	113.12	38.84
12	26.0	10.8	250	41.5	2261	322.7	368.07	103.52	112.54
13	26.0	11.0C	249	40.8	2252	318.3	434.47C	105.34C	112.06C
14	27.8	10.5C	248	40.5	2240	316.3	84.76C	119.03C	125.45C
15	28.1	11.2	248	38.9	2254	303.8	72.81	120.01	102.95
16	25.4	11.4	248	38.4	2249	299.6	70.17	125.68	88.32
17	25.8	10.6	247	40.3	2257	313.2	502.96	99.92	69.32
18	19.9	10.7	246	39.1	2269	303.3	488.83	96.08	71.80
19	20.0	10.7	246	39.3	2253	305.3	538.09	94.80	73.36
20	19.0	11.2	246	37.4	2269	288.7	310.99	108.19	118.95
21	26.0	10.5	247	40.6	2269	313.0	564.45	96.41	175.21
22	15.6	13.6C	231	19.2	2334	152.9	66.59C	80.67C	36.78C
23	.1	14.4	219	14.9	2336	121.6	70.08	74.59	13.71
Max :	28.1	14.4	251	41.5	2337	322.7	564.45	125.68	175.21
Min :	.0	10.5	208	13.0	2240	116.4	10.29	69.98	.52
Mean :	11.7	12.2	234	27.2	2300	217.3	181.60	92.89	55.25
Hours :	24	24	24	24	24	24	24	24	24

Status : 'C' - Less than ## Data, 'P' - Power Fail, 'D' - Disabled, 'T' - Out-of-Control, 'F' - Boiler Off-Line,  
 Flags : 'B' - Bad Status, 'C' - Calibration, 'M' - Maintenance, 'O' - Analog Overrange, 'U' - Analog Underrange,  
 'A' - Arithmetic Error, 'S' - Maximum, '2' - Minimum, 'R' - Rate of Change, 'H' - High-High Alarm,  
 'L' - Low-Low Alarm, 'h' - High Alarm, 'l' - Low Alarm, 'J' - High Rate of Change, 'j' - Low Rate of Change,  
 'V' - DIS #1 Obs, 'W' - DIS #2 Obs, 'X' - DIS #3 Obs, 'Y' - DIS #4 Obs, 'Z' - DIS #5 Obs.

Current Date: 09/14/03  
 Current Time: 00:35

Daily Parameter Report - Auxiliary Averages  
 Wheelabrator Ridge Energy  
 09/13/03

Logger Name : RIDGE  
 Logger Id : 01

Stack :  
 Boiler/Unit : Opac

Parameter : STAKOPAC  
 Units : PERCENT

Date	Time	Minute										
		006M	00	06	12	18	24	30	36	42	48	54
09/13/03	00:00	.00	.00	.00	.00	.00	.00	.00	.00	.00	.00	.00
09/13/03	01:00	.00	.00	.00	.00	.00	.00	.00	.00	.00	.00	.00
09/13/03	02:00	.00	.00	.00	.00	.00	.00	.00	.00	.00	.00	.00
09/13/03	03:00	.00	.00	.00	.00	.00	.00	.00	.00	.00	.00	.00
09/13/03	04:00	.00	.00	.00	.00	.00	.00	.00	.00	.00	.00	.00
09/13/03	05:00	.00	.00	.00	.00	.00	.00	.00	.00	.00	.00	.00
09/13/03	06:00	.00	.00	.00	.00	.00	.00	.00	.00	.00	.00	.00
09/13/03	07:00	.00	.00	.00	.00	.00	.00	.00	.00	.00	.00	.00
09/13/03	08:00	.00	.00	.00	.00	.00	.00	.00	.00	.00	.00	.00
09/13/03	09:00	.00	.00	.00B	.00B	.00	.00	.00	.00	.00	.00	.00
09/13/03	10:00	.00	.00	.00	.00	.00	.00	.00	.00	.00	.00	.00
09/13/03	11:00	.00	.00	.00	.00	.00	.00	.00	.00	.00	.00	.00
09/13/03	12:00	.00	.00	.00	.00	.00	.00	.00	.00	.00	.00	.00
09/13/03	13:00	.00	.00	.00	.00	.00	.00	.00	.00	.00	.00	.00
09/13/03	14:00	.00	.00	.00	.00	.00	.00	.00	.00	.00	.00	.00
09/13/03	15:00	.00	.00	.00	.00	.00	.00	.00	.00	.00	.00	.00
09/13/03	16:00	.00	.00	.00	.00	.00	.00	.00	.00	.00	.00	.00
09/13/03	17:00	.00	.00	.00	.00	.00	.00	.00	.00	.00	.00	.00
09/13/03	18:00	.00	.00	.00	.00	.00	.00	.00	.00	.00	.00	.00
09/13/03	19:00	.00	.00	.00	.00	.00	.00	.00	.00	.00	.00	.00
09/13/03	20:00	.00	.00	.00	.00	.00	.00	.00	.00	.00	.00	.00
09/13/03	21:00	.00	.00	.00	.00	.00	.00	.00	.00	.00	.00	.00
09/13/03	22:00	.00	.00	.00	.00	.00	.00	.00	.00	.00	.00	.00
09/13/03	23:00	.00	.00	.00	.00	.00	.00	.00	.00	.00	.00	.00

Max .00  
 Min .00  
 Mean .00

Records 240

Status : 'L' - Less than ## Data, 'P' - Power Fail, 'D' - Disabled, 'T' - Out-of-Control, 'F' - Boiler Off-Line,  
 Flags : 'B' - Bad Status, 'C' - Calibration, 'M' - Maintenance, 'O' - Analog Overrange, 'U' - Analog Underrange,  
 'A' - Arithmetic Error, 'H' - Maximum, 'I' - Minimum, 'R' - Rate of Change, 'H' - High-High Alarm,  
 'L' - Low-Low Alarm, 'h' - High Alarm, 'l' - Low Alarm, 'J' - High Rate of Change, 'j' - Low Rate of Change,  
 'V' - DIS #1 Obs, 'W' - DIS #2 Obs, 'X' - DIS #3 Obs, 'Y' - DIS #4 Obs, 'Z' - DIS #5 Obs

Current Date : 09/13/03  
 Current Time : 00:27

Daily Data Report - Hourly Averages  
 Wheelabrator Ridge Energy  
 09/12/03

Logger Id : 01

Logger Name : Ridge Energy

Interval : 001H

Param :	TIREFEED	O2WET	STKFLOW	MGWATTS	FTEMP	STMFLOW	CO#/HR	NO#/HR	SO2#/HR
Units :	KPPH	VOL%	KSCFM	MW	DEG_F	KPPH	#/HR	#/HR	#/HR
Stack :									
Unit :		Blr1	Blr1	Blr1	Blr1	Blr1	Blr1	Blr1	Blr1
Hour :	-----								
00	.0	12.5	225	21.6	2336	168.8	9.83	103.07	20.20
01	.0	12.9	227	21.5	2336	167.2	7.98	105.62	22.14
02	.0	13.4	224	19.2	2337	150.0	13.13	95.75	17.54
03	.0	13.9	221	17.6	2336	135.2	28.47	83.29	12.55
04	.0	14.5	213	14.8	2336	116.1	105.25	71.49	8.18
05	.0	14.7	212	14.5	2336	116.7	45.84	71.25	8.09
06	.0	13.7	219	17.8	2336	141.9	14.46	84.20	11.82
07	.0	13.9	217	16.3	2336	128.2	23.52	78.39	49.00
08	.0	13.9	219	15.9	2337	127.5	57.51	67.22	24.06
09	.0	14.0	216C	16.3	2336	130.1	24.20C	67.76C	22.02C
10	4.1	12.0C	239	29.1	2325	227.1	81.22C	114.17C	57.82C
11	18.9	10.7	252	42.3	2265	330.3	559.00	93.67	66.16
12	28.1	11.3	251	40.3	2257	314.5	268.64	112.85	53.37
13	24.1	10.8	250	40.9	2264	315.7	620.57	95.18	35.81
14	22.4	11.3	250	39.1	2256	305.9	224.50	113.30	14.73
15	19.6	11.7	248	36.3	2293	279.7	230.13	113.70	17.82
16	25.2	11.4	245	35.7	2267	267.6	327.86	99.55	110.45
17	25.9	10.9	244	39.7	2253	307.3	490.26	95.22	193.15
18	20.6	11.8	244	33.0	2293	254.9	61.14	115.91	39.71
19	19.0	11.3	247	37.6	2259	291.9	175.62	112.47	88.76
20	24.2	11.1	249	39.9	2258	309.8	445.08	99.47	94.48
21	23.6	11.6	244	36.6	2272	286.8	191.40	106.51	273.91
22	16.8	13.9C	239	15.9	2330	134.9	96.30C	80.67C	10.73C
23	2.1	13.8	230	14.9	2336	129.0	44.12	82.91	2.68
Max :	28.1	14.7	252	42.3	2337	330.3	620.57	115.91	273.91
Min :	.0	10.7	212	14.5	2253	116.1	7.98	67.22	2.68
Mean :	11.4	12.5	234	27.4	2304	214.0	172.75	94.32	52.30
Hours :	24	24	24	24	24	24	24	24	24

Status : 'C' - Less than 3% Data, 'P' - Power Fail, 'D' - Disabled, 'T' - Out-of-Control, 'F' - Boiler Off-Line,  
 Flags : 'B' - Bad Status, 'C' - Calibration, 'M' - Maintenance, 'O' - Analog Overrange, 'U' - Analog Underrange,  
 'A' - Arithmetic Error, '+' - Maximum, '-' - Minimum, 'R' - Rate of Change, 'H' - High-High Alarm,  
 'L' - Low-Low Alarm, 'h' - High Alarm, 'l' - Low Alarm, 'j' - High Rate of Change, 'j' - Low Rate of Change,  
 'V' - DIS #1 Obs, 'W' - DIS #2 Obs, 'X' - DIS #3 Obs, 'Y' - DIS #4 Obs, 'Z' - DIS #5 Obs



Current Date : 09/13/03  
 Current Time : 00:35

Daily Parameter Report - Auxiliary Averages  
 Wheelabrator Ridge Energy  
 09/12/03

Logger Name : RIDGE  
 Logger Id : 01

Stack :  
 Boiler/Unit : Opac

Parameter : STAKOPAC  
 Units : PERCENT

Date	Time	Minute										
		006M	00	06	12	18	24	30	36	42	48	54
09/12/03	00:00	.00	.00	.00	.00	.00	.00	.00	.00	.00	.00	.00
09/12/03	01:00	.00	.00	.00	.00	.00	.00	.00	.00	.00	.00	.00
09/12/03	02:00	.00	.00	.00	.00	.00	.00	.00	.00	.00	.00	.00
09/12/03	03:00	.00	.00	.00	.00	.00	.00	.00	.00	.00	.00	.00
09/12/03	04:00	.00	.00	.00	.00	.00	.00	.00	.00	.00	.00	.00
09/12/03	05:00	.00	.00	.00	.00	.00	.00	.00	.00	.00	.00	.00
09/12/03	06:00	.00	.00	.00	.00	.00	.00	.00	.00	.00	.00	.00
09/12/03	07:00	.00	.00	.00	.00	.00	.00	.00	.00	.00	.00	.00
09/12/03	08:00	.00	.00	.00	.00	.00	.00	.00	.00	.00	.00	.00
09/12/03	09:00	.00	.00	.00B	.00B	.00	.00	.00	.00	.00	.00	.00
09/12/03	10:00	.00	.00	.00	.00	.00	.00	.00	.00	.00	.00	.00
09/12/03	11:00	.00	.00	.00	.00	.00	.00	.00	.00	.00	.00	.00
09/12/03	12:00	.00	.00	.00	.00	.00	.00	.00	.00	.00	.00	.00
09/12/03	13:00	.00	.00	.00	.00	.00	.00	.00	.00	.00	.00	.00
09/12/03	14:00	.00	.00	.00	.00	.00	.00	.00	.00	.00	.00	.00
09/12/03	15:00	.00	.00	.00	.00	.00	.00	.00	.00	.00	.00	.00
09/12/03	16:00	.00	.00	.00	.00	.00	.00	.00	.00	.00	.00	.00
09/12/03	17:00	.00	.00	.00	.00	.00	.00	.00	.00	.00	.00	.00
09/12/03	18:00	.00	.00	.00	.00	.00	.00	.00	.00	.00	.00	.00
09/12/03	19:00	.00	.00	.00	.00	.00	.00	.00	.00	.00	.00	.00
09/12/03	20:00	.00	.00	.00	.00	.00	.00	.00	.00	.00	.00	.00
09/12/03	21:00	.00	.00	.00	.00	.00	.00	.00	.00	.00	.00	.00
09/12/03	22:00	.00	.00	.00	.00	.00	.00	.00	.00	.00	.00	.00
09/12/03	23:00	.00	.00	.00	.00	.00	.00	.00	.00	.00	.00	.00

Max : .00  
 Min : .00  
 Mean : .00

Records : 240

tatus : '<' - Less than ### Data, 'P' - Power Fail, 'D' - Disabled, 'T' - Out-of-Control, 'F' - Boiler Off-Line,  
 tags : 'B' - Bad Status, 'C' - Calibration, 'M' - Maintenance, 'O' - Analog Overrange, 'U' - Analog Underrange,  
 'A' - Arithmetic Error, '+' - Maximum, '-' - Minimum, 'R' - Rate of Change, 'H' - High-High Alarm,  
 'L' - Low-Low Alarm, 'h' - High Alarm, 'l' - Low Alarm, 'J' - High Rate of Change, 'j' - Low Rate of Change,  
 'V' - DIS #1 Obs, 'W' - DIS #2 Obs, 'X' - DIS #3 Obs, 'Y' - DIS #4 Obs, 'Z' - DIS #5 Obs.

Current Date: 09/11/03  
 Current Time: 00:27

Daily Data Report - Hourly Averages  
 Wheelabrator Ridge Energy  
 09/10/03

Logger Id : 01

Logger Name : Ridge Energy

Interval : 001H

Param :	TIREFEED	O2WET	STKFLOW	MGWATTS	FTEMP	STMFLOW	CO#/HR	NO#/HR	SO2#/HR
Units :	KPPH	VOL%	KSCFM	MW	DEG F	KPPH	#/HR	#/HR	#/HR
Stack :									
Unit :		Blr1	Blr1	Blr1	Blr1	Blr1	Blr1	Blr1	Blr1
Hour :									
00	.0	13.0	189	15.1	2336	133.1	15.61	65.04	6.76
01	.0	13.0	199	15.4	2336	134.8	19.11	67.88	5.16
02	.0	13.2	199	15.3	2337	133.4	17.39	69.82	4.28
03	.0	13.9	208	15.7	2336	134.4	31.96	68.60	4.35
04	.1	13.6	203	15.6	2336	134.2	24.02	70.44	14.20
05	.2	13.2	208	16.1	2336	135.3	28.81	71.25	16.20
06	.0	14.3	212	14.1	2336	122.2	163.60	70.09	11.32
07	.0	15.0	215	12.2	2336	110.2	297.56	68.16	4.43
08	.2	14.8	219	12.6	2336	113.5	237.79	71.81	3.47
09	.0	14.6	218C	14.1	2336	126.6	216.22C	72.56C	6.25C
10	1.8	12.2C	235	24.8	2317	201.1	34.44C	102.07C	20.23C
11	15.8	10.8	250	37.0	2286	290.0	194.73	118.50	38.71
12	23.1	10.9	251	40.4	2260	318.2	200.21	116.73	56.59
13	27.7	10.9	250	41.0	2253	323.5	142.07	120.45	87.40
14	24.3	10.9	248	40.4	2257	318.2	231.23	111.09	141.55
15	26.9	11.2	249	39.1	2264	308.1	156.07	111.11	81.29
16	26.0	11.0	245	39.1	2258	297.9	327.22	102.53	128.76
17	23.5	10.8	246	39.2	2265	308.9	316.83	107.43	132.30
18	22.6	11.1	248	37.5	2276	295.6	161.78	117.30	78.14
19	21.8	11.4	248	37.4	2275	294.1	109.67	113.51	90.09
20	26.2	11.1	247	38.4	2272	302.6	293.84	107.21	177.24
21	25.7	10.9	247	39.7	2262	312.1	411.87	108.56	182.23
22	17.4	14.6C	227	16.5	2333	141.5	163.41C	72.30C	30.25C
23	.2	14.5	215	13.9	2336	126.4	109.01	66.60	19.38
Max :	27.7	15.0	251	41.0	2337	323.5	411.87	120.45	182.23
Min :	.0	10.8	189	12.2	2253	110.2	15.61	65.04	3.47
Mean :	11.8	12.5	228	26.3	2303	213.2	162.69	90.46	55.86
Hours :	24	24	24	24	24	24	24	24	24

Status : '<' - Less than ## Data, 'P' - Power Fail, 'D' - Disabled, 'T' - Out-of-Control, 'F' - Boiler Off-Line,  
 Flags : 'B' - Bad Status, 'C' - Calibration, 'M' - Maintenance, 'O' - Analog Overrange, 'U' - Analog Underrange,  
 'A' - Arithmetic Error, '+', '-' - Maximum, Minimum, 'R' - Rate of Change, 'H' - High-High Alarm,  
 'L' - Low-Low Alarm, 'h' - High Alarm, 'l' - Low Alarm, 'J' - High Rate of Change, 'j' - Low Rate of Change,  
 'V' - DIS #1 Obs, 'W' - DIS #2 Obs, 'X' - DIS #3 Obs, 'Y' - DIS #4 Obs, 'Z' - DIS #5 Obs

Current Date 09/11/03  
 Current Time 00:35

Daily Parameter Report - Auxiliary Averages  
 Wheelabrator Ridge Energy  
 09/10/03

Logger Name : RIDGE  
 Logger Id : 01

Stack :  
 Boiler/Unit : Opac

Parameter : STAKOPAC  
 Units : PERCENT

Date	Time	00	06	12	18	24	30	36	42	48	54
09/10/03	00:00	.00	.00	.00	.00	.00	.00	.00	.00	.00	.00
09/10/03	01:00	.00	.00	.00	.00	.00	.00	.00	.00	.00	.00
09/10/03	02:00	.00	.00	.00	.00	.00	.00	.00	.00	.00	.00
09/10/03	03:00	.00	.00	.00	.00	.00	.00	.00	.00	.00	.00
09/10/03	04:00	.00	.00	.00	.00	.00	.00	.00	.00	.00	.00
09/10/03	05:00	.00	.00	.00	.00	.00	.00	.00	.00	.00	.00
09/10/03	06:00	.00	.00	.00	.00	.00	.00	.00	.00	.00	.00
09/10/03	07:00	.00	.00	.00	.00	.00	.00	.00	.00	.00	.00
09/10/03	08:00	.00	.00	.00	.00	.00	.00	.00	.00	.00	.00
09/10/03	09:00	.00	.00	.00B	.00B	.00	.00	.00	.00	.00	.00
09/10/03	10:00	.00	.00	.00	.00	.00	.00	.00	.00	.00	.00
09/10/03	11:00	.00	.00	.00	.00	.00	.00	.00	.00	.00	.00
09/10/03	12:00	.00	.00	.00	.00	.00	.00	.00	.00	.00	.00
09/10/03	13:00	.00	.00	.00	.00	.00	.00	.00	.00	.00	.00
09/10/03	14:00	.00	.00	.00	.00	.00	.00	.00	.00	.00	.00
09/10/03	15:00	.00	.00	.00	.00	.00	.00	.00	.00	.00	.00
09/10/03	16:00	.00	.00	.00	.00	.00	.00	.00	.00	.00	.00
09/10/03	17:00	.00	.00	.00	.00	.00	.00	.00	.00	.00	.00
09/10/03	18:00	.00	.00	.00	.00	.00	.00	.00	.00	.00	.00
09/10/03	19:00	.00	.00	.00	.00	.00	.00	.00	.00	.00	.00
09/10/03	20:00	.00	.00	.00	.00	.00	.00	.00	.00	.00	.00
09/10/03	21:00	.00	.00	.00	.00	.00	.00	.00	.00	.00	.00
09/10/03	22:00	.00	.00	.00	.00	.00	.00	.00	.00	.00	.00
09/10/03	23:00	.00	.00	.00	.00	.00	.00	.00	.00	.00	.00

Max .00  
 Min .00  
 Mean .00

Records 240

Status: 'K' - Less than 1/4 Data, 'P' - Power Fail, 'D' - Disabled, 'T' - Out-of-Control, 'F' - Boiler Off-Line,  
 'B' - Bad Status, 'C' - Calibration, 'M' - Maintenance, 'O' - Analog Overrange, 'U' - Analog Underrange,  
 'A' - Arithmetic Error, '+' - Maximum, '-' - Minimum, 'R' - Rate of Change, 'H' - High-High Alarm,  
 'L' - Low-Low Alarm, 'h' - High Alarm, 'l' - Low Alarm, 'J' - High Rate of Change, 'j' - Low Rate of Change,  
 'V' - DIS #1 Obs, 'W' - DIS #2 Obs, 'X' - DIS #3 Obs, 'Y' - DIS #4 Obs, 'Z' - DIS #5 Obs.

Current Date: 09/10/03  
 Current Time: 00:27

Daily Data Report - Hourly Averages  
 Wheelabrator Ridge Energy  
 09/09/03

Logger Id : 01

Logger Name : Ridge Energy

Interval : 001H

Param :	TIREFEED	O2WET	STKFLOW	MGWATTS	FTEMP	STMFLOW	CO#/HR	NO#/HR	SO2#/HR
Units :	KPPH	VOL%	KSCFM	MW	DEG_F	KPPH	#/HR	#/HR	#/HR
Stack :									
Unit :		Blr1	Blr1	Blr1	Blr1	Blr1	Blr1	Blr1	Blr1
Hour :									
00	-1	13.0	205	16.2	2336	136.1	24.36	74.72	11.45
01	-1	13.0	204	16.1	2337	135.0	27.77	73.21	10.65
02	-1	13.3	202	14.5	2337	122.7	32.44	69.42	7.75
03	-1	13.3	201	14.7	2336	124.2	27.14	65.90	7.06
04	-1	13.2	201	14.8	2337	124.6	36.23	67.96	9.02
05	.0	13.2	202	14.7	2336	125.0	48.95	67.98	12.38
06	.0	13.3	205	14.8	2336	126.4	50.63	66.02	11.49
07	.0	13.2	204	14.4	2336	123.3	37.87	68.87	6.36
08	-1	13.9	211	14.7	2337	124.2	101.08	69.88	3.67
09	-1	13.8	206C	15.6	2336	132.1	48.37C	71.28C	3.63C
10	.3	12.7C	229	24.8	2327	200.1	263.00C	94.96C	220.34C
11	14.3	11.2	252	40.8	2255	321.5	119.51	118.46	130.09
12	25.3	11.1	252	41.3	2245	325.1	87.71	120.37	95.94
13	24.5	11.1	251	41.1	2252	323.5	152.46	115.42	73.64
14	25.6	11.3	248	40.0	2242	316.1	82.48	114.01	104.34
15	29.5	10.6	247	41.0	2239	324.1	341.79	102.97	149.57
16	25.0	10.9	247	40.8	2241	321.5	219.44	109.54	109.39
17	25.2	11.2	249	40.4	2231	319.1	401.57	97.28	144.07
18	27.9	10.5	245	39.9	2229	315.9	145.92	107.75	147.77
19	29.4	10.7	248	40.8	2268	318.0	354.74	105.03	131.87
20	25.0	10.8	249	41.2	2263	321.1	338.06	103.88	104.37
21	28.9	10.6	248	42.6	2258	332.7	495.31	105.16	168.56
22	15.2	13.2C	214	20.7	2331	170.0	22.08C	71.98C	4.28C
23	.5	12.8	192	15.5	2336	135.4	13.32	70.58	.23
Max :	29.5	13.9	252	42.6	2337	332.7	495.31	120.37	220.34
Min :	-1	10.5	192	14.4	2229	122.7	13.32	65.90	.23
Mean :	12.3	12.2	226	27.6	2295	221.6	144.68	88.86	69.50
Hours :	24	24	24	24	24	24	24	24	24

Status : 'C' - Less than 5% Data, 'P' - Power Fail, 'D' - Disabled, 'O' - Out-of-Control, 'F' - Boiler Off-Line,  
 'B' - Bad Status, 'C' - Calibration, 'M' - Maintenance, 'R' - Analog Overrange, 'U' - Analog Underrange,  
 'A' - Arithmetic Error, 'S' - Maximum, 'N' - Minimum, 'R' - Rate of Change, 'H' - High-High Alarm,  
 'L' - Low-Low Alarm, 'h' - High Alarm, 'l' - Low Alarm, 'J' - High Rate of Change, 'j' - Low Rate of Change,  
 'V' - DIS #1 Obs, 'W' - DIS #2 Obs, 'X' - DIS #3 Obs, 'Y' - DIS #4 Obs, 'Z' - DIS #5 Obs.

BEST AVAILABLE COPY

urrent Date : 09/11/03  
 urrent Time : 07:31

Daily Parameter Report - Auxiliary Averages  
 Wheelabrator Ridge Energy

Logger Name : Ridge Energy  
 Logger Id : 01  
 Parameter : STAKOPAC  
 Units : PERCENT

Stack :  
 Boiler/Unit : Opac

Time	Minute									
	00	06	12	18	24	30	36	42	48	
09/03 00:00	.00	.00	.00	.00	.00	.00	.00	.00	.00	.00
09/03 01:00	.00	.00	.00	.00	.00	.00	.00	.00	.00	.00
09/03 02:00	.00	.00	.00	.00	.00	.00	.00	.00	.00	.00
09/03 03:00	.00	.00	.00	.00	.00	.00	.00	.00	.00	.00
09/03 04:00	.00	.00	.00	.00	.00	.00	.00	.00	.00	.00
09/03 05:00	.00	.00	.00	.00	.00	.00	.00	.00	.00	.00
09/03 06:00	.00	.00	.00	.00	.00	.00	.00	.00	.00	.00
09/03 07:00	.00	.00	.00	.00	.00	.00	.00	.00	.00	.00
09/03 08:00	.00	.00	.00	.00	.00	.00	.00	.00	.00	.00
09/03 09:00	.00	.00	.00B	.00B	.00	.00	.00	.00	.00	.00
09/03 10:00	.00	.00	.00	.00	.00	.00	.00	.00	.00	.00
09/03 11:00	.00	.00	.00	.00	.00	.00	.00	.00	.00	.00
09/03 12:00	.00	.00	.00	.00	.00	.00	.00	.00	.00	.00
09/03 13:00	.00	.00	.00	.00	.00	.00	.00	.00	.00	.00
09/03 14:00	.00	.00	.00	.00	.00	.00	.00	.00	.00	.00
09/03 15:00	.00	.00	.00	.00	.00	.00	.00	.00	.00	.00
09/03 16:00	.00	.00	.00	.00	.00	.00	.00	.00	.00	.00
09/03 17:00	.00	.00	.00	.00	.00	.00	.00	.00	.00	.00
09/03 18:00	.00	.00	.00	.00	.00	.00	.00	.00	.00	.00
09/03 19:00	.00	.00	.00	.00	.00	.00	.00	.00	.00	.00
09/03 20:00	.00	.00	.00	.00	.00	.00	.00	.00	.00	.00
09/03 21:00	.00	.00	.00	.00	.00	.00	.00	.00	.00	.00
09/03 22:00	.00	.00	.00	.00	.00	.00	.00	.00	.00	.00
09/03 23:00	.00	.00	.00	.00	.00	.00	.00	.00	.00	.00
Max	.00									
Min	.00									
Mean	.00									

Current Date: 09/09/03  
 Current Time: 00:27

Daily Data Report - Hourly Averages  
 Wheelabrator Ridge Energy  
 09/08/03

Logger Id : 01

Logger Name : Ridge Energy

Interval : 001H

Param :	TIREFEED	O2WET	STKFLOW	MGWATTS	FTEMP	STMFLOW	CO#/HR	NO#/HR	SO2#/HR
Units :	KPPH	VOL%	KSCFM	MW	DEG F	KPPH	#/HR	#/HR	#/HR
Stack :									
Unit :	Blr1	Blr1	Blr1	Blr1	Blr1	Blr1	Blr1	Blr1	Blr1
hour	-----								
00	5.1	13.1	192	15.3	2336	128.2	21.22	61.29	22.03
01	.7	13.2	195	15.4	2336	128.9	31.07	59.78	20.05
02	.0	13.1	202	15.1	2336	127.4	45.85	65.26	16.80
03	.0	12.7	198	15.9	2337	132.9	23.42	64.97	22.44
04	.0	13.8	202	13.8	2336	117.0	73.70	65.09	23.95
05	-1	13.9	212	15.0	2336	126.0	101.70	65.90	28.24
06	.0	13.9	226	16.6	2336	134.6	137.82	73.62	17.98
07	-1	14.4	226	14.0	2336	121.2	120.14	85.43	7.41
08	.2	14.6	219	11.8	2328	105.2	325.11	73.46	5.91
09	.6	14.6	221C	14.0	2333	122.0	125.66C	75.88C	6.41C
10	2.0	12.6C	245	26.0	2319	207.8	92.42C	110.99C	60.29C
11	19.3	10.8	251	39.4	2251	308.0	179.02	114.97	120.00
12	24.3	10.9	251	40.0	2251	315.3	204.93	119.18	69.61
13	26.7	11.3	251	38.9	2262	305.2	158.08	119.53	55.07
14	24.3	11.1	249	39.4	2246	311.5	140.54	120.97	79.62
15	27.6	11.2	247	39.6	2240	313.2	122.29	117.21	149.20
16	23.7	11.1	249	38.7	2255	303.5	433.04	100.99	110.71
17	22.4	11.5	248	37.9	2258	297.8	439.60	102.22	141.93
18	28.9	11.1	245	39.1	2250	307.5	457.76	105.53	177.98
19	28.4	10.4	246	40.2	2261	313.8	536.20	91.63	194.73
20	23.4	10.4	244	39.4	2262	308.2	540.50	91.45	177.00
21	24.6	11.4	246	36.9	2268	280.6	252.59	107.10	165.39
22	18.3	13.9C	227	17.4	2334	144.9	89.12C	80.41C	31.61C
23	.5	13.4	205	15.1	2336	130.9	54.26	72.75	16.11
fax :	28.9	14.6	251	40.2	2337	315.3	540.50	120.97	194.73
fin :	-1	10.4	192	11.8	2240	105.2	21.22	59.78	5.91
fean :	12.5	12.4	229	26.5	2298	212.2	196.08	89.40	71.69
four :	24	24	24	24	24	24	24	24	24

status : 'L' - Low-Low Alarm, 'L' - Low-Low Alarm, 'V' - DIS #1 Obs,  
 'A' - Arithmetic Error, 'A' - Arithmetic Error, 'V' - DIS #1 Obs,  
 'B' - Bad Status, 'B' - Bad Status, 'W' - DIS #2 Obs,  
 'C' - Calibration, 'C' - Calibration, 'X' - DIS #3 Obs,  
 'D' - Disabled, 'D' - Disabled, 'Y' - DIS #4 Obs,  
 'E' - Out-of-Control, 'E' - Out-of-Control, 'Z' - DIS #5 Obs,  
 'F' - Boiler Off-Line, 'F' - Boiler Off-Line,  
 'G' - Maintenance, 'G' - Maintenance,  
 'H' - Analog Overrange, 'H' - Analog Overrange,  
 'I' - Analog Underrange, 'I' - Analog Underrange,  
 'J' - Race of Change, 'J' - Race of Change,  
 'K' - High-High Alarm, 'K' - High-High Alarm,  
 'M' - High Alarm, 'M' - High Alarm,  
 'N' - Low Alarm, 'N' - Low Alarm,  
 'O' - High Rate of Change, 'O' - High Rate of Change,  
 'P' - Low Rate of Change, 'P' - Low Rate of Change,  
 'Q' - DIS #1 Obs, 'Q' - DIS #1 Obs,  
 'R' - DIS #2 Obs, 'R' - DIS #2 Obs,  
 'S' - DIS #3 Obs, 'S' - DIS #3 Obs,  
 'T' - DIS #4 Obs, 'T' - DIS #4 Obs,  
 'U' - DIS #5 Obs, 'U' - DIS #5 Obs

Current Date : 09/09/03  
 Current Time : 00:35

Daily Parameter Report - Auxiliary Averages  
 Wheelabrator Ridge Energy  
 09/08/03

Logger Name : RIDGE  
 Logger Id : 01

Stack :  
 Boiler/Unit : Opac

Parameter : STAKOPAC  
 Units : PERCENT

Date	Time	Minute										
		006M	00	06	12	18	24	30	36	42	48	54
09/08/03	00:00	.00	.00	.00	.00	.00	.00	.00	.00	.00	.00	.00
09/08/03	01:00	.00	.00	.00	.00	.00	.00	.00	.00	.00	.00	.00
09/08/03	02:00	.00	.00	.00	.00	.00	.00	.00	.00	.00	.00	.00
09/08/03	03:00	.00	.00	.00	.00	.00	.00	.00	.00	.00	.00	.00
09/08/03	04:00	.00	.00	.00	.00	.00	.00	.00	.00	.00	.00	.00
09/08/03	05:00	.00	.00	.00	.00	.00	.00	.00	.00	.00	.00	.00
09/08/03	06:00	.00	.00	.00	.00	.00	.00	.00	.00	.00	.00	.00
09/08/03	07:00	.00	.00	.00	.00	.00	.00	.00	.00	.00	.00	.00
09/08/03	08:00	.00	.00	.00	.00	.00	.00	.00	.00	.00	.00	.00
09/08/03	09:00	.00	.00	.00B	.00B	.00	.00	.00	.00	.00	.00	.00
09/08/03	10:00	.00	.00	.00	.00	.00	.00	.00	.00	.00	.00	.00
09/08/03	11:00	.00	.00	.00	.00	.00	.00	.00	.00	.00	.00	.00
09/08/03	12:00	.00	.00	.00	.00	.00	.00	.00	.00	.00	.00	.00
09/08/03	13:00	.00	.00	.00	.00	.00	.00	.00	.00	.00	.00	.00
09/08/03	14:00	.00	.00	.00	.00	.00	.00	.00	.00	.00	.00	.00
09/08/03	15:00	.00	.00	.00	.00	.00	.00	.00	.00	.00	.00	.00
09/08/03	16:00	.00	.00	.00	.00	.00	.00	.00	.00	.00	.00	.00
09/08/03	17:00	.00	.00	.00	.00	.00	.00	.00	.00	.00	.00	.00
09/08/03	18:00	.00	.00	.00	.00	.00	.00	.00	.00	.00	.00	.00
09/08/03	19:00	.00	.00	.00	.00	.00	.00	.00	.00	.00	.00	.00
09/08/03	20:00	.00	.00	.00	.00	.00	.00	.00	.00	.00	.00	.00
09/08/03	21:00	.00	.00	.00	.00	.00	.00	.00	.00	.00	.00	.00
09/08/03	22:00	.00	.00	.00	.00	.00	.00	.00	.00	.00	.00	.00
09/08/03	23:00	.00	.00	.00	.00	.00	.00	.00	.00	.00	.00	.00
	Max	.00										
	Min	.00										
	Mean	.00										
	Records	240										

Status : 'C' - Less than 5% Data, 'P' - Power Fail, 'D' - Disabled, 'T' - Out-of-Control, 'F' - Boiler Off-Line,  
 Flags : 'B' - Bad Status, 'C' - Calibration, 'M' - Maintenance, 'O' - Analog Overrange, 'U' - Analog Underrange,  
 'A' - Arithmetic Error, 'H' - Maximum, 'L' - Minimum, 'R' - Rate of Change, 'N' - High-High Alarm,  
 'I' - Low-Low Alarm, 'h' - High Alarm, 'l' - Low Alarm, 'J' - High Rate of Change, 'j' - Low Rate of Change,  
 'V' - DIS #1 Obs, 'W' - DIS #2 Obs, 'X' - DIS #3 Obs, 'Y' - DIS #4 Obs, 'Z' - DIS #5 Obs.

Current Date 09/08/03  
 Current Time 00:27

Daily Data Report - Hourly Averages  
 Wheelabrator Ridge Energy  
 09/07/03

Logger Id : 01

Logger Name : Ridge Energy

Interval : 001H

Param :	TIREFEED	O2WET	STKFLOW	MGWATTS	FTEMP	STMFLOW	CO#/HR	NO#/HR	SO2#/HR
Units :	KPPH	VOL%	KSCFM	MW	DEG_F	KPPH	#/HR	#/HR	#/HR
Stack :									
Unit :		Blr1	Blr1	Blr1	Blr1	Blr1	Blr1	Blr1	Blr1
Hour	-----								
00	.3	12.8	188	16.0	2337	131.4	9.53	59.69	8.15
01	.1	12.8	187	15.9	2336	129.2	12.24	57.07	5.40
02	.0	13.0	191	16.0	2337	129.5	20.67	57.07	2.87
03	.0	13.2	195	16.1	2336	129.3	23.09	59.21	2.70
04	.0	12.8	193	15.8	2337	128.2	28.19	57.96	6.44
05	.0	13.2	202	16.5	2336	133.2	44.01	56.69	17.14
06	.0	13.3	208	16.4	2336	132.0	32.42	57.36	18.93
07	.0	13.4	228	18.4	2337	146.3	62.06	71.71	28.28
08	.0	13.9	216	16.2	2335	132.7	97.36	69.32	10.95
09	-1	14.0	211C	15.4	2337	128.4	70.61C	64.34C	12.64C
10	3.8	11.3C	242	28.9	2322	227.9	211.42C	104.91C	22.72C
11	21.0	10.6C	249	39.1	2268	307.9	347.79C	106.77C	100.67C
12	28.2	10.8	248	37.8	2255	295.7	140.15	110.07	120.31
13	26.3	10.4	247	39.3	2242	309.1	200.33	104.42	165.62
14	23.9	11.1	250	39.6	2237	313.3	120.90	111.16	144.28
15	29.2	11.1	251	39.6	2238	312.4	150.86	106.33	123.10
16	27.3	11.1	250	39.3	2242	310.5	218.48	105.65	129.38
17	25.1	11.1	250	39.7	2251	312.7	122.45	117.54	152.36
18	25.1	10.9	250	39.5	2259	309.8	219.68	107.25	129.57
19	34.4	10.7	250	40.6	2262	317.1	345.71	99.13	164.07
20	27.5	10.6	250	39.6	2258	309.0	247.75	110.86	145.77
21	24.6	10.9	252	38.7	2275	300.6	323.35	99.65	95.11
22	7.1	12.9C	216	17.3	2335	140.5	36.33C	64.30C	20.51C
23	.0	12.8	189	15.7	2336	130.6	10.62	56.95	25.98
Max :	34.4	14.0	252	40.6	2337	317.1	347.79	117.54	165.62
Min :	-1	10.4	187	15.4	2237	128.2	9.53	56.69	2.70
Mean :	12.7	12.0	226	27.4	2298	217.4	129.00	83.98	68.87
Hours :	24	24	24	24	24	24	24	24	24

Status : 'C' - Less than ## Data, 'P' - Power Fail, 'D' - Disabled, 'T' - Out-of-Control, 'F' - Boiler Off-Line,  
 Flags : 'B' - Bad Status, 'C' - Calibration, 'M' - Maintenance, 'O' - Analog Overrange, 'U' - Analog Underrange,  
 'A' - Arithmetic Error, '+' - Maximum, '-' - Minimum, 'R' - Rate of Change, 'H' - High-High Alarm,  
 'L' - Low-Low Alarm, 'h' - High Alarm, 'l' - Low Alarm, 'U' - High Rate of Change, 'L' - Low Rate of Change,  
 'V' - DIS #1 Obs, 'W' - DIS #2 Obs, 'X' - DIS #3 Obs, 'Y' - DIS #4 Obs, 'Z' - DIS #5 Obs.



Current Date : 09/08/03  
 Current Time : 00:35

Daily Parameter Report - Auxiliary Averages  
 Wheelabrator Ridge Energy  
 09/07/03

Logger Name : RIDGE  
 Logger Id : 01

Stack :  
 Boiler/Unit : Opac

Parameter : STAKOPAC  
 Units : PERCENT

Date	Time	Minute										
		00M	00	06	12	18	24	30	36	42	48	54
09/07/03	00:00	.00	.00	.00	.00	.00	.00	.00	.00	.00	.00	.00
09/07/03	01:00	.00	.00	.00	.00	.00	.00	.00	.00	.00	.00	.00
09/07/03	02:00	.00	.00	.00	.00	.00	.00	.00	.00	.00	.00	.00
09/07/03	03:00	.00	.00	.00	.00	.00	.00	.00	.00	.00	.00	.00
09/07/03	04:00	.00	.00	.00	.00	.00	.00	.00	.00	.00	.00	.00
09/07/03	05:00	.00	.00	.00	.00	.00	.00	.00	.00	.00	.00	.00
09/07/03	06:00	.00	.00	.00	.00	.00	.00	.00	.00	.00	.00	.00
09/07/03	07:00	.00	.00	.00	.00	.00	.00	.00	.00	.00	.00	.00
09/07/03	08:00	.00	.00	.00	.00	.00	.00	.00	.00	.00	.00	.00
09/07/03	09:00	.00	.00	.00B	.00B	.00	.00	.00	.00	.00	.00	.00
09/07/03	10:00	.00	.00	.00	.00	.00	.00	.00	.00	.00	.00	.00
09/07/03	11:00	.00	.00	.00	.00	.00	.00	.00	.00	.00	.00	.00
09/07/03	12:00	.00	.00	.00	.00	.00	.00	.00	.00	.00	.00	.00
09/07/03	13:00	.00	.00	.00	.00	.00	.00	.00	.00	.00	.00	.00
09/07/03	14:00	.00	.00	.00	.20	.00	.00	.00	.00	.00	.00	.00
09/07/03	15:00	.00	.00	.00	.00	.00	.00	.00	.00	.00	.00	.00
09/07/03	16:00	.00	.00	.00	.00	.00	.00	.00	.00	.00	.00	.00
09/07/03	17:00	.00	.00	.00	.00	.00	.00	.00	.00	.00	.00	.00
09/07/03	18:00	.00	.00	.00	.00	.00	.00	.00	.00	.00	.00	.00
09/07/03	19:00	.00	.00	.00	.00	.00	.00	.00	.00	.00	.00	.00
09/07/03	20:00	.00	.00	.00	.00	.00	.00	.00	.00	.00	.00	.00
09/07/03	21:00	.00	.00	.00	.00	.00	.00	.00	.00	.00	.00	.00
09/07/03	22:00	.00	.00	.00	.00	.00	.00	.00	.00	.00	.00	.00
09/07/03	23:00	.00	.00	.00	.00	.00	.00	.00	.00	.00	.00	.00

Max .20  
 Min .00  
 Mean .00

Records 240

Status : < - Less than ## Data, 'P' - Power Fail, 'D' - Disabled, 'T' - Out-of-Control, 'F' - Boiler Off-Line,  
 Flags : 'B' - Bad Status, 'C' - Calibration, 'M' - Maintenance, 'O' - Analog Overrange, 'U' - Analog Underrange,  
 'A' - Arithmetic Error, 'L' - Maximum, 'l' - Minimum, 'R' - Rate of Change, 'H' - High-High Alarm,  
 'L' - Low-Low Alarm, 'h' - High Alarm, 'l' - Low Alarm, 'J' - High Rate of Change, 'j' - Low Rate of Change,  
 'V' - DIS #1 Obs, 'W' - DIS #2 Obs, 'X' - DIS #3 Obs, 'Y' - DIS #4 Obs, 'Z' - DIS #5 Obs.

Current Date 09/07/03  
 Current Time 00:10

Daily Data Report - Hourly Averages  
 Wheelabrator Ridge Energy  
 09/06/03

Logger Id : 01

Logger Name : Ridge Energy

Interval : 001H

Param :	TIREFEED	O2WET	STKFLOW	MGWATTS	FTEMP	STMFLOW	CO#/HR	NO#/HR	SO2#/HR
Units :	KPPH	VOL%	KSCFM	MW	DEG_F	KPPH	#/HR	#/HR	#/HR
Stack :									
Unit :	Blr1	Blr1	Blr1	Blr1	Blr1	Blr1	Blr1	Blr1	Blr1
Hour									
00	.0	14.6	203	15.0	2336	127.7	45.14	60.60	16.88
01	.0	14.4	208	15.1	2336	125.3	35.84	65.26	17.55
02	.0	14.3	210	16.4	2336	135.7	42.55	70.61	11.21
03	.0	14.4	202	15.1	2336	130.8	49.30	60.45	12.59
04	.0	14.1	192	14.7	2330	127.7	30.64	53.25	14.63
05	.0	13.9	193	14.8	2336	128.7	21.85	50.35	32.34
06	.0	14.2	195	15.2	2325	130.5	33.60	52.84	36.86
07	.0	14.8C	223	13.1	2324	107.0	204.05C	74.54C	18.57C
08	-.1	13.2	199	16.4	2336	139.8	19.09	69.87	15.34
09	-.1	13.3	197C	14.9	2335	129.0	37.47C	68.53C	10.02C
10	3.9	10.6C	243	33.3	2290	264.1	207.38C	95.98C	86.16C
11	22.8	10.2	249	40.3	2264	316.3	460.55	92.01	169.52
12	25.6	11.0	250	40.1	2250	317.0	245.93	101.55	119.45
13	25.2	10.6	248	39.8	2253	313.7	368.11	94.73	113.34
14	25.9	11.1	247	40.2	2238	317.2	282.00	104.40	179.87
15	27.8	11.0	248	40.3	2237	319.4	340.61	99.52	116.62
16	25.6	11.2	248	37.7	2261	296.8	320.04	106.25	15.88
17	25.9	11.1	246	38.9	2251	305.8	336.63	102.28	81.52
18	26.8	10.6	243	38.8	2245	305.0	341.56	99.90	105.87
19	28.9	10.0	243	40.5	2250	316.2	617.43	84.29	122.91
20	28.7	10.6	246	40.7	2248	318.4	438.13	98.42	101.29
21	27.5	11.1	247	39.5	2274	306.9	312.92	106.77	49.36
22	13.0	12.4C	200	17.8	2335	142.7	12.92C	62.28C	26.41C
23	.0	12.8	190	16.5	2334	133.4	8.78	60.64	16.18
Max :	28.9	14.8	250	40.7	2336	319.4	617.43	106.77	179.87
Min :	-.1	10.0	190	13.1	2237	107.0	8.78	50.35	10.02
Mean :	12.8	12.3	224	27.3	2294	219.0	200.52	80.64	62.10
Hours :	24	24	24	24	24	24	24	24	24

Status : '<' - Less than ## Data, 'P' - Power Fail, 'D' - Disabled, 'T' - Out-of-Control, 'F' - Boiler Off-Line,  
 Flags : 'B' - Bad Status, 'C' - Calibration, 'M' - Maintenance, 'O' - Analog Overrange, 'U' - Analog Underrange,  
 'A' - Arithmetic Error, '+' - Maximum, '-' - Minimum, 'R' - Rate of Change, 'H' - High-High Alarm,  
 'L' - Low-Low Alarm, 'h' - High Alarm, 'l' - Low Alarm, 'J' - High Rate of Change, 'j' - Low Rate of Change,  
 'V' - DIS #1 Obs, 'W' - DIS #2 Obs, 'X' - DIS #3 Obs, 'Y' - DIS #4 Obs, 'Z' - DIS #5 Obs

Current Date : 09/07/03  
 Current Time : 00:35

Daily Parameter Report - Auxiliary Averages  
 Wheelabrator Ridge Energy  
 09/06/03

Logger Name : RIDGE  
 Logger Id : 01

Stack :  
 Boiler/Unit : Opac

Parameter : STAKOPAC  
 Units : PERCENT

Date	Time	Minute										
		00G	00	06	12	18	24	30	36	42	48	54
09/06/03	00:00	.00	.00	.00	.00	.00	.00	.00	.00	.00	.00	.00
09/06/03	01:00	.00	.00	.00	.00	.00	.00	.00	.00	.00	.00	.00
09/06/03	02:00	.00	.00	.00	.00	.00	.00	.00	.00	.00	.00	.00
09/06/03	03:00	.00	.00	.00	.00	.00	.00	.00	.00	.00	.00	.00
09/06/03	04:00	.00	.00	.00	.00	.00	.00	.00	.00	.00	.00	.00
09/06/03	05:00	.00	.00	.00	.00	.00	.00	.00	.00	.00	.00	.00
09/06/03	06:00	.00	.00	.00	.00	.00	.00	.00	.00	.00	.00	.00
09/06/03	07:00	.00	.00	.00	.00	.00	.00	.00	.00	.00	.00	.00
09/06/03	08:00	.00	.00	.00	.00	.00	.00	.00	.00	.00	.00	.00
09/06/03	09:00	.00	.00	.00B	.00B	.00	.00	.00	.00	.00	.00	.00
09/06/03	10:00	.00	.00	.00	.00	.00	.00	.00	.00	.00	.00	.00
09/06/03	11:00	.00	.00	.00	.00	.00	.00	.00	.00	.00	.00	.00
09/06/03	12:00	.00	.00	.00	.00	.00	.00	.00	.00	.00	.00	.00
09/06/03	13:00	.00	.00	.00	.00	.00	.00	.00	.00	.00	.00	.00
09/06/03	14:00	.00	.00	.00	.00	.00	.00	.00	.00	.00	.00	.00
09/06/03	15:00	.00	.00	.00	.00	.00	.00	.00	.00	.00	.00	.00
09/06/03	16:00	.00	.00	.00	.00	.00	.00	.00	.00	.00	.00	.00
09/06/03	17:00	.00	.00	.00	.00	.00	.00	.00	.00	.00	.00	.00
09/06/03	18:00	.00	.00	.00	.00	.00	.00	.00	.00	.00	.00	.00
09/06/03	19:00	.00	.00	.00	.00	.00	.00	.00	.00	.00	.00	.00
09/06/03	20:00	.00	.00	.00	.00	.00	.00	.00	.00	.00	.00	.00
09/06/03	21:00	.00	.00	.00	.00	.00	.00	.00	.00	.00	.00	.00
09/06/03	22:00	.00	.00	.00	.00	.00	.00	.00	.00	.00	.00	.00
09/06/03	23:00	.00	.00	.00	.00	.00	.00	.00	.00	.00	.00	.00

Max : .00  
 Min : .00  
 Mean : .00  
 Records : 240

Status : '<' - Less than ## Data, 'P' - Power Fail, 'D' - Disabled, 'T' - Out-of-Control, 'F' - Boiler Off-Line,  
 Flags : 'B' - Bad Status, 'C' - Calibration, 'M' - Maintenance, 'O' - Analog Overrange, 'U' - Analog Underrange,  
 'A' - Arithmetic Error, 'X' - Maximum, 'L' - Minimum, 'R' - Rate of Change, 'H' - High-High Alarm,  
 'I' - Low-Low Alarm, 'h' - High Alarm, 'l' - Low Alarm, 'J' - High Rate of Change, 'j' - Low Rate of Change,  
 'V' - DIS #1 Obs, 'W' - DIS #2 Obs, 'X' - DIS #3 Obs, 'Y' - DIS #4 Obs, 'Z' - DIS #5 Obs.

Current Date: 09/06/03  
 Current Time: 00:27

Daily Data Report - Hourly Averages  
 Wheelabrator Ridge Energy  
 09/05/03

Logger Id : 01

Logger Name : Ridge Energy

Interval : 001H

Param :	TIREFEED	O2WET	STKFLOW	MGWATTS	FTEMP	STMFLOW	CO#/HR	NO#/HR	SO2#/HR
Units :	KPPH	VOL%	KSCFM	MW	DEG_F	KPPH	#/HR	#/HR	#/HR
Stack :									
Unit :									
hour :									
00	-1	13.6	200	15.9	2333	130.2	29.37	82.52	5.63
01	-1	13.7	200	14.4	2336	118.4	38.85	73.56	4.08
02	-1	14.4	200	14.0	2336	115.5	50.79	71.62	3.68
03	-1	14.3	201	14.4	2336	118.4	32.21	73.36	5.40
04	-1	14.1	201	14.8	2336	120.5	21.85	79.30	4.82
05	-1	14.0	200	14.3	2337	117.5	21.66	76.74	6.68
06	-1	13.9	201	14.5	2337	118.5	15.42	79.22	6.33
07	0	14.3	208	14.2	2336	115.7	38.68	81.65	8.20
08	0	14.5	211	14.7	2336	119.5	69.22	78.00	2.58
09	0	14.0	212C	16.8	2336	135.1	29.74C	87.15C	3.75C
10	7	11.6C	228	26.8	2327	210.1	28.88C	132.56C	54.13C
11	12.4	11.3	247	36.0	2291	280.8	104.39	111.59	22.08
12	22.3	11.3	246	38.0	2272	298.0	75.52	108.69	93.58
13	24.2	11.3	250	38.8	2283	303.8	126.01	108.35	77.98
14	25.8	11.3	249	40.4	2269	315.9	151.87	110.04	140.54
15	27.8	11.5	247	39.2	2282	305.0	319.99	96.74	110.49
16	24.5	11.6	248	38.6	2291	300.7	248.06	93.07	76.87
17	22.6	11.8	246	37.8	2290	293.6	118.64	97.65	86.16
18	22.0	11.9	243	37.9	2268	295.7	64.88	101.59	68.66
19	25.6	11.6	246	40.0	2276	310.6	278.19	94.11	123.00
20	30.8	11.2	248	41.0	2287	318.0	453.28	87.35	166.15
21	27.2	11.3	248	40.3	2307	312.6	352.39	91.92	189.25
22	16.6	14.1C	223	22.0	2330	174.5	95.02C	68.46C	89.37C
23	4.0	14.5	205	15.4	2336	130.3	50.50	69.97	33.74
Max :	30.8	14.5	250	41.0	2337	318.0	453.28	132.56	189.25
Min :	-1	11.2	200	14.0	2268	115.5	15.42	68.46	2.58
Mean :	11.9	12.8	225	26.7	2311	210.8	117.31	89.80	57.63
Hours :	24	24	24	24	24	24	24	24	24

Status Legend:  
 'Z' - Less than 5% Data, 'P' - Power Fail, 'D' - Disabled, 'T' - Out-of-Control, 'F' - Boiler Off-Line,  
 'B' - Bad Status, 'C' - Calibration, 'M' - Maintenance, 'O' - Analog Overrange, 'U' - Analog Underrange,  
 'A' - Arithmetic Error, 'H' - High Alarm, 'L' - Low Alarm, 'R' - Rate of Change, 'H' - High-High Alarm,  
 'L' - Low-Low Alarm, 'H' - High Alarm, 'L' - Low Alarm, 'J' - High Rate of Change, 'J' - Low Rate of Change,  
 'V' - DIS #1 Obs, 'W' - DIS #2 Obs, 'X' - DIS #3 Obs, 'Y' - DIS #4 Obs, 'Z' - DIS #5 Obs.

Current Date : 09/06/03  
 Current Time : 00:35

Daily Parameter Report - Auxiliary Averages  
 Wheelabrator Ridge Energy  
 09/05/03

Logger Name : RIDGE  
 Logger Id : 01

Stack :  
 Boiler/Unit : Opac

Parameter : STAKOPAC  
 Units : PERCENT

Date	Time 006M	Minute									
		00	06	12	18	24	30	36	42	48	54
09/05/03	00:00	.00	.00	.00	.00	.00	.00	.00	.00	.00	.00
09/05/03	01:00	.00	.00	.00	.00	.00	.00	.00	.00	.00	.00
09/05/03	02:00	.00	.00	.00	.00	.00	.00	.00	.00	.00	.00
09/05/03	03:00	.00	.00	.00	.00	.00	.00	.00	.00	.00	.00
09/05/03	04:00	.00	.00	.00	.00	.00	.00	.00	.00	.00	.00
09/05/03	05:00	.00	.00	.00	.00	.00	.00	.00	.00	.00	.00
09/05/03	06:00	.00	.00	.00	.00	.00	.00	.00	.00	.00	.00
09/05/03	07:00	.00	.00	.00	.00	.00	.00	.00	.00	.00	.00
09/05/03	08:00	.00	.00	.00	.00	.00	.00	.00	.00	.00	.00
09/05/03	09:00	.00	.00	.00B	.00B	.00	.00	.00	.00	.00	.00
09/05/03	10:00	.00	.00	.00	.00	.00	.00	.00	.00	.00	.00
09/05/03	11:00	.00	.00	.00	.00	.00	.00	.00	.00	.00	.00
09/05/03	12:00	.00	.00	.00	.00	.00	.00	.00	.00	.00	.00
09/05/03	13:00	.00	.00	.00	.00	.00	.00	.00	.00	.00	.00
09/05/03	14:00	.00	.00	.00	.00	.00	.00	.00	.00	.00	.00
09/05/03	15:00	.00	.00	.00	.00	.00	.00	.00	.00	.00	.00
09/05/03	16:00	.00	.00	.00	.00	.00	.00	.00	.00	.00	.00
09/05/03	17:00	.00	.00	.00	.00	.00	.00	.00	.00	.00	.00
09/05/03	18:00	.00	.00	.00	.00	.00	.00	.00	.00	.00	.00
09/05/03	19:00	.00	.00	.00	.00	.00	.00	.00	.00	.00	.00
09/05/03	20:00	.00	.00	.00	.00	.00	.00	.00	.00	.00	.00
09/05/03	21:00	.00	.00	.00	.00	.00	.00	.00	.00	.00	.00
09/05/03	22:00	.00	.00	.00	.00	.00	.00	.00	.00	.00	.00
09/05/03	23:00	.00	.00	.00	.00	.00	.00	.00	.00	.00	.00

Max .00  
 Min .00  
 Mean .00  
 Records 240

tatus : '<' - Less than ## Data, 'P' - Power Fail, 'D' - Disabled, 'T' - Out-of-Control, 'F' - Boiler Off-Line,  
 lags : 'B' - Bad Status, 'C' - Calibration, 'M' - Maintenance, 'O' - Analog Overrange, 'U' - Analog Underrange,  
 'A' - Arithmetic Error, 'r' - Maximum, 'l' - Minimum, 'R' - Rate of Change, 'H' - High-High Alarm,  
 'L' - Low-Low Alarm, 'h' - High Alarm, 'l' - Low Alarm, 'J' - High Rate of Change, 'j' - Low Rate of Change,  
 'V' - DIS #1 Obs, 'W' - DIS #2 Obs, 'X' - DIS #3 Obs, 'Y' - DIS #4 Obs, 'Z' - DIS #5 Obs.

Current Date 09/05/03  
 Current Time 00:27

Daily Data Report - Hourly Averages  
 Wheelabrator Ridge Energy  
 09/04/03

Logger Id : 01

Logger Name : Ridge Energy

Interval : 001H

Param :	TIREFEED	O2WET	STKFLOW	MGWATTS	FTEMP	STMFLOW	CO#/HR	NO#/HR	SO2#/HR
Units :	KPPH	VOL%	KSCFM	MW	DEG_F	KPPH	#/HR	#/HR	#/HR
Stack :									
Unit :		Blr1	Blr1	Blr1	Blr1	Blr1	Blr1	Blr1	Blr1
Hour	-----								
00	.0	14.9	202	12.1	2310	94.0	185.87	66.67	20.17
01	.0	14.4	207	13.8	2325	108.3	88.86	64.64	26.60
02	.0	14.0	207	15.5	2335	121.6	33.81	72.12	22.48
03	.0	14.1	205	15.3	2335	121.5	45.23	67.86	14.40
04	.0	14.2	206	14.3	2336	113.3	48.74	66.86	5.24
05	.0	14.4	204	14.0	2328	110.2	82.50	62.28	.83
06	.0	14.1	205	14.3	2336	114.1	63.52	64.36	.43
07	1.0	14.6	204	12.6	2336	100.2	127.51	63.52	1.44
08	.8	14.8	201	12.7	2336	100.4	174.30	64.87	1.30
09	.0	14.6	205C	13.7	2336	108.5	140.57C	68.24C	1.59C
10	4.6	11.8C	235	28.3	2291	220.6	26.17C	136.90C	72.50C
11	21.5	11.4	244	36.0	2260	278.2	42.45	132.57	92.73
12	28.4	11.7	243	37.4	2251	289.0	45.58	132.09	104.07
13	27.6	11.4	244	39.7	2237	310.1	80.10	133.72	106.45
14	29.0	11.6	244	37.9	2257	293.4	54.47	133.24	82.00
15	27.0	11.5	247	38.2	2266	295.8	55.97	137.00	35.73
16	28.1	10.8	246	40.6	2265	313.2	613.37	103.46	94.90
17	23.6	12.0	241	34.2	2267	263.0	218.84	119.79	69.98
18	21.2	11.5	240	37.3	2251	287.0	143.98	123.96	65.31
19	30.8	10.8	246	41.2	2256	318.0	435.40	118.19	67.83
20	26.4	10.8	247	40.9	2275	316.7	370.36	120.15	96.26
21	26.3	11.4	247	38.0	2292	294.8	157.07	125.30	35.29
22	16.9	13.4C	218	18.6	2336	150.8	28.81C	90.44C	21.00C
23	.4	14.1	205	14.9	2336	126.8	43.14	77.49	9.08
Max :	30.8	14.9	247	41.2	2336	318.0	613.37	137.00	106.45
Min :	.0	10.8	201	12.1	2237	94.0	26.17	62.28	.43
Mean :	13.1	12.8	225	25.9	2298	202.1	137.78	97.74	43.65
Hours :	24	24	24	24	24	24	24	24	24

Status : '<' - Less than 5% Data, 'P' - Power Fail, 'D' - Disabled, 'T' - Out-of-Control, 'F' - Boiler Off-Line,  
 Flags : 'B' - Bad Status, 'C' - Calibration, 'M' - Maintenance, 'O' - Analog Overrange, 'U' - Analog Underrange,  
 'A' - Arithmetic Error, 'x' - Maximum, 'l' - Minimum, 'R' - Rate of Change, 'H' - High-High Alarm,  
 'L' - Low-Low Alarm, 'h' - High Alarm, 'l' - Low Alarm, 'J' - High Rate of Change, 'j' - Low Rate of Change,  
 'V' - DIS #1 Obs, 'W' - DIS #2 Obs, 'X' - DIS #3 Obs, 'Y' - DIS #4 Obs, 'Z' - DIS #5 Obs.

Current Date: 09/05/03  
 Current Time: 00:35

Daily Parameter Report - Auxiliary Averages  
 Wheelabrator Ridge Energy  
 09/04/03

Logger Name : RIDGE  
 Logger Id : 01

Stack :  
 Boiler/Unit : Opac

Parameter : STAKOPAC  
 Units : PERCENT

Date	Time 006M	Minute									
		00	06	12	18	24	30	36	42	48	54
09/04/03	00:00	.00	.00	.00	.00	.00	.00	.00	.00	.00	.00
09/04/03	01:00	.00	.00	.00	.00	.00	.00	.00	.00	.00	.00
09/04/03	02:00	.00	.00	.00	.00	.00	.00	.00	.00	.00	.00
09/04/03	03:00	.00	.00	.00	.00	.00	.00	.00	.00	.00	.00
09/04/03	04:00	.00	.00	.00	.00	.00	.00	.00	.00	.00	.00
09/04/03	05:00	.00	.00	.00	.00	.00	.00	.00	.00	.00	.00
09/04/03	06:00	.00	.00	.00	.00	.00	.00	.00	.00	.00	.00
09/04/03	07:00	.00	.00	.00	.00	.00	.00	.00	.00	.00	.00
09/04/03	08:00	.00	.00	.00	.00	.00	.00	.00	.00	.00	.00
09/04/03	09:00	.00	.00	.00B	.00B	.00	.00	.00	.00	.00	.00
09/04/03	10:00	.00	.00	.00	.00	.00	.00	.00	.00	.00	.00
09/04/03	11:00	.00	.00	.00	.00	.00	.00	.00	.00	.00	.00
09/04/03	12:00	.00	.00	.00	.00	.00	.00	.00	.00	.00	.00
09/04/03	13:00	.00	.00	.00	.00	.00	.00	.00	.00	.00	.00
09/04/03	14:00	.00	.00	.00	.00	.00	.00	.00	.00	.00	.00
09/04/03	15:00	.00	.00	.00	.00	.00	.00	.00	.00	.00	.00
09/04/03	16:00	.00	.00	.00	.00	.00	.00	.00	.00	.00	.00
09/04/03	17:00	.00	.00	.00	.00	.00	.00	.00	.00	.00	.00
09/04/03	18:00	.00	.00	.00	.00	.00	.00	.00	.00	.00	.00
09/04/03	19:00	.00	.00	.00	.00	.00	.00	.00	.00	.00	.00
09/04/03	20:00	.00	.00	.00	.00	.00	.00	.00	.00	.00	.00
09/04/03	21:00	.00	.00	.00	.00	.00	.00	.00	.00	.00	.00
09/04/03	22:00	.00	.00	.00	.00	.00	.00	.00	.00	.00	.00
09/04/03	23:00	.00	.00	.00	.00	.00	.00	.00	.00	.00	.00

Max. : .00  
 Min. : .00  
 Mean : .00  
 Records : 240

Status : '<' - Less than ## Data, 'P' - Power Fail, 'D' - Disabled, 'T' - Out-of-Control, 'F' - Boiler Off-Line,  
 Flags : 'B' - Bad Status, 'C' - Calibration, 'M' - Maintenance, 'O' - Analog Overrange, 'U' - Analog Underrange,  
 'A' - Arithmetic Error, '+M' - Maximum, '-M' - Minimum, 'R' - Rate of Change, 'H' - High-High Alarm,  
 'L' - Low-Low Alarm, 'h' - High Alarm, 'l' - Low Alarm, 'J' - High Rate of Change, 'j' - Low Rate of Change,  
 'V' - DIS #1 Obs, 'W' - DIS #2 Obs, 'X' - DIS #3 Obs, 'Y' - DIS #4 Obs, 'Z' - DIS #5 Obs.

Current Date: 09/03/03  
 Current Time: 00:27

Daily Data Report - Hourly Averages  
 Wheelabrator Ridge Energy  
 09/02/03

Logger Id : 01

Logger Name : Ridge Energy

Interval : 001H

Param :	TIREFEED	O2WET	STKFLOW	MGWATTS	FTEMP	STMFLOW	CO#/HR	NO#/HR	SO2#/HR
Units :	KPPH	VOL%	KSCFM	MW	DEG_F	KPPH	#/HR	#/HR	#/HR
Stack :									
Unit :		Blr1	Blr1	Blr1	Blr1	Blr1	Blr1	Blr1	Blr1
Hour :									
00	.0	12.1	187	15.3	2330	126.9	21.19	49.39	9.51
01	.0	12.1	188	15.6	2337	128.8	20.64	52.54	5.02
02	.0	12.3	192	15.3	2336	127.0	14.35	55.39	8.15
03	-.1	12.4	196	15.8	2336	130.6	18.34	56.69	13.30
04	.0	14.3	202	10.6	2306	88.8	294.76	62.97	19.35
05	.0	13.4	212	14.7	2336	121.3	96.29	63.01	16.51
06	.0	13.3	208	16.0	2323	128.8	48.22	65.75	4.14
07	.0	12.8	202	14.5	2331	120.4	52.53	66.09	3.11
08	.0	9.6	203	14.9	2336	123.8	85.17	37.14	27.65
09	.0	14.0	199C	12.9	2332	109.9	.19C	33.17C	47.57C
10	2.6	17.5C	227	24.0	2316	194.1	16.25C	182.60C	245.87C
11	20.1	10.9	248	38.7	2255	307.4	102.27	123.85	135.97
12	30.2	11.2	248	37.2	2235	296.3	45.51	118.25	95.40
13	25.6	10.7	244	35.5	2260	275.9	274.80	99.40	51.10
14	26.2	10.5C	247	38.9	2259	306.4	363.75C	103.52C	58.29C
15	25.6	10.6C	247	41.1	2233	324.6	155.31C	113.00C	73.50C
16	26.1	11.0	247	37.9	2251	299.1	65.48	115.85	43.44
17	29.9	10.6	248	38.9	2259	305.6	279.49	112.42	59.06
18	23.6	10.2	248	41.0	2254	321.1	462.18	111.01	76.41
19	28.7	10.4	248	37.7	2279	291.7	405.89	104.58	27.59
20	24.6	9.6	247	41.1	2284	315.1	694.31	87.14	32.48
21	19.4	13.4	238	20.5	2309	153.8	343.91	87.74	65.61
22	2.1	16.9C	233	.5	1540	.6	253.30C	15.08C	16.04C
23	4.3	19.2	245	.0	1063	.0	103.08	13.65	4.67
Max :	30.2	19.2	248	41.1	2337	324.6	694.31	182.60	245.87
Min :	-.1	9.6	187	.0	1063	.0	.19	13.65	3.11
Mean :	12.0	12.5	225	24.1	2213	191.6	175.72	80.43	47.49
Hours :	24	24	24	24	24	24	24	24	24

Status : '<' - Less than ## Data, 'P' - Power fail, 'D' - Disabled, 'T' - Out-of-Control, 'F' - Boiler Off-Line,  
 Flags : 'B' - Bad Status, 'C' - Calibration, 'M' - Maintenance, 'O' - Analog Overrange, 'U' - Analog Underrange,  
 'A' - Arithmetic Error, 'X' - Maximum, 'N' - Minimum, 'R' - Rate of Change, 'H' - High-High Alarm,  
 'L' - Low-Low Alarm, 'H' - High Alarm, 'L' - Low Alarm, 'J' - High Rate of Change, 'J' - Low Rate of Change,  
 'V' - DIS #1 Obs, 'W' - DIS #2 Obs, 'X' - DIS #3 Obs, 'Y' - DIS #4 Obs, 'Z' - DIS #5 Obs



Current Date: 09/03/03  
 Current Time: 00:35

Daily Parameter Report - Auxiliary Averages  
 Wheelabrator Ridge Energy  
 09/02/03

Logger Name : RIDGE  
 Logger Id : 01

Stack :  
 Boiler/Unit : Opac

Parameter : STAKOPAC  
 Units : PERCENT

Date	Time	Minute										
		00M	00	06	12	18	24	30	36	42	48	54
09/02/03	00:00	.00	.00	.00	.00	.00	.00	.00	.00	.00	.00	.00
09/02/03	01:00	.00	.00	.00	.00	.00	.00	.00	.00	.00	.00	.00
09/02/03	02:00	.00	.00	.00	.00	.00	.00	.00	.00	.00	.00	.00
09/02/03	03:00	.00	.00	.00	.00	.00	.00	.00	.00	.00	.00	.00
09/02/03	04:00	.00	.00	.00	.00	.00	.00	.00	.00	.00	.00	.00
09/02/03	05:00	.00	.00	.00	.00	.00	.00	.00	.00	.00	.00	.00
09/02/03	06:00	.00	.00	.00	.00	.00	.00	.00	.00	.00	.00	.00
09/02/03	07:00	.00	.00	.00	.00	.00	.00	.00	.00	.00	.00	.00
09/02/03	08:00	.00	.00	.00	.00	.00	.00	.00	.00	.00	.00	.00
09/02/03	09:00	.00	.00	.00B	.00B	1.25	39.93H	39.54H	40.11H	39.49H	33.53H	.00
09/02/03	10:00	36.14H	39.90H	39.76H	39.04H	39.96H	.00	.00	.00	.00	.00	.00
09/02/03	11:00	.00	.00	.00	.00	.00	.00	.00	.00	.00	.00	.00
09/02/03	12:00	.00	.00	.00	.00	.00	.00	.00	.00	.00	.00	.00
09/02/03	13:00	.00	.00	.00	.00	.00	.00	.00	.00	.00	.00	.00
09/02/03	14:00	.00	.00	.00	.00	.00	.00	.00	.00	.00	.00	.00
09/02/03	15:00	.00	.00	.00	.00	.00	.00	.00	.00	.00	.00	.00
09/02/03	16:00	.00	.00	.00	.00	.00	.00	.00	.00	.00	.00	.00
09/02/03	17:00	.00	.00	.00	.00	.00	.00	.00	.00	.00	.00	.00
09/02/03	18:00	.00	.00	.00	.00	.00	.00	.00	.00	.00	.00	.00
09/02/03	19:00	.00	.00	.00	.00	.00	.00	.00	.00	.00	.00	.00
09/02/03	20:00	.00	.00	.00	.00	.00	.00	.00	.00	.00	.00	.00
09/02/03	21:00	.00	.00	.00	.00	.00	.00	.00	.00	.00	.00	.00
09/02/03	22:00	.00	.00	.00	.00	.00	.00	.00	.00	.00	.00	.00
09/02/03	23:00	.00	.00	.00	.00	.00	.00	.00	.00	.00	.00	.00

Max 40.11  
 Min .00  
 Mean 1.62  
 Records 240

Status : 'L' - Less than 33% Data, 'P' - Power Fail, 'D' - Disabled, 'T' - Out-of-Control, 'F' - Boiler Off-Line,  
 Flags : 'B' - Bad Status, 'C' - Calibration, 'M' - Maintenance, 'O' - Analog Overrange, 'U' - Analog Underrange,  
 'A' - Arithmetic Error, '+' - Maximum, '-' - Minimum, 'R' - Rate of Change, 'H' - High-High Alarm,  
 'L' - Low-Low Alarm, 'H' - High Alarm, 'l' - Low Alarm, 'J' - High Rate of Change, 'j' - Low Rate of Change,  
 'V' - DIS #1 Obs, 'W' - DIS #2 Obs, 'X' - DIS #3 Obs, 'Y' - DIS #4 Obs, 'Z' - DIS #5 Obs.

Current Date: 09/02/03  
 Current Time: 00:27

Daily Data Report - Hourly Averages  
 Wheelabrator Ridge Energy  
 09/01/03

Logger Id : 01

Logger Name : Ridge Energy

Interval : 001H

Param :	TIREFEED	O2WET	STKFLOW	MGWATTS	FTEMP	STMFLOW	CO#/HR	NO#/HR	SO2#/HR
Units :	KPPH	VOL%	KSCFM	MW	DEG_F	KPPH	#/HR	#/HR	#/HR
Stack :									
Unit :		Blr1	Blr1	Blr1	Blr1	Blr1	Blr1	Blr1	Blr1
Hour :	-----								
00.	.0	12.6	184	14.5	2326	123.2	24.34	54.20	2.01
01.	.0	12.5	184	15.6	2332	131.3	15.39	53.20	2.14
02.	.0	12.1	178	15.3	2328	129.9	19.81	50.25	4.06
03.	.0	12.5	188	15.2	2336	128.3	41.46	50.43	7.38
04.	.0	12.3	183	15.8	2332	132.1	17.03	54.95	12.33
05.	.0	12.9	197	15.5	2334	130.9	32.30	60.42	7.36
06.	.0	12.3	193	16.1	2336	133.5	18.70	55.26	12.21
07.	.0	11.9	191	15.9	2336	130.3	45.04	49.70	25.52
08.	.0	11.6	188	15.9	2336	130.0	41.48	47.63	34.11
09.	.0	12.0	186C	16.0	2336	131.3	30.32C	47.88C	24.08C
10.	3.6	10.6C	237	30.7	2330	239.3	237.02C	90.13C	16.79C
11.	19.4	9.7	253	40.7	2286	318.6	452.24	91.31	84.29
12.	24.4	10.3	252	37.6	2290	287.5	397.78	92.26	69.60
13.	22.3	11.2	251	36.3	2295	271.7	82.88	108.44	85.22
14.	25.2	10.7	251	38.1	2285	294.9	74.60	115.05	114.72
15.	25.6	10.4	250	41.1	2276	321.0	596.36	88.31	123.75
16.	23.5	10.4	251	39.9	2266	313.0	247.68	106.37	112.79
17.	26.1	10.9	251	37.9	2269	296.4	152.16	111.81	124.54
18.	23.0	11.2	251	33.5	2306	259.0	167.11	104.69	67.39
19.	22.0	10.5	249	38.2	2286	283.4	468.53	92.95	179.49
20.	26.8	10.3	251	40.1	2280	310.3	377.00	98.99	144.65
21.	27.5	10.4	252	40.7	2261	316.8	293.37	106.44	148.40
22.	18.0	12.3C	203	18.7	2335	151.5	32.43C	61.42C	8.58C
23.	.4	12.0C	180	15.7	2332	131.3	8.28C	56.26C	18.25C
Max :	27.5	12.9	253	41.1	2336	321.0	596.36	115.05	179.49
Min :	.0	9.7	178	14.5	2261	123.2	8.28	47.63	2.01
Mean :	12.0	11.4	219	26.9	2310	212.3	161.35	77.01	59.57
Hours :	24	24	24	24	24	24	24	24	24

Status : '<' - Less than ## Data, 'P' - Power Fail, 'D' - Disabled, 'T' - Out-of-Control, 'F' - Boiler Off-Line,  
 Flags : 'B' - Bad Status, 'C' - Calibration, 'M' - Maintenance, 'O' - Analog Overrange, 'U' - Analog Underrange,  
 'A' - Arithmetic Error, 'M' - Maximum, 'R' - Rate of Change, 'H' - High-High Alarm,  
 'L' - Low-Low Alarm, 'h' - High Alarm, 'l' - Low Alarm, 'J' - High Rate of Change, 'j' - Low Rate of Change,  
 'V' - DIS #1 Obs, 'W' - DIS #2 Obs, 'X' - DIS #3 Obs, 'Y' - DIS #4 Obs, 'Z' - DIS #5 Obs.

Current Date: 09/02/03  
 Current Time: 00:35

Daily Parameter Report - Auxiliary Averages  
 Wheelabrator Ridge Energy  
 09/01/03

Logger Name : RIDGE  
 Logger Id : 01

Stack :  
 Boiler/Unit : Opac

Parameter : STAKOPAC  
 Units : PERCENT

Date	Time 006M	Minute										
		00	06	12	18	24	30	36	42	48	54	
09/01/03	00:00	.00	.00	.00	.00	.00	.00	.00	.00	.00	.00	.00
09/01/03	01:00	.00	.00	.00	.00	.00	.00	.00	.00	.00	.00	.00
09/01/03	02:00	.00	.00	.00	.00	.00	.00	.00	.00	.00	.00	.00
09/01/03	03:00	.00	.00	.00	.00	.00	.00	.00	.00	.00	.00	.00
09/01/03	04:00	.00	.00	.00	.00	.00	.00	.00	.00	.00	.00	.00
09/01/03	05:00	.00	.00	.00	.00	.00	.00	.00	.00	.00	.00	.00
09/01/03	06:00	.00	.00	.00	.00	.00	.00	.00	.00	.00	.00	.00
09/01/03	07:00	.00	.00	.00	.00	.00	.00	.00	.00	.00	.00	.00
09/01/03	08:00	.00	.00	.00	.00	.00	.00	.00	.00	.00	.00	.00
09/01/03	09:00	.00	.00	.00B	.00B	.00	.00	.00	.00	.00	.00	.00
09/01/03	10:00	.00	.00	.00	.00	.00	.00	.00	.00	.00	.00	.00
09/01/03	11:00	.00	.00	.00	.00	.00	.00	.00	.00	.00	.00	.00
09/01/03	12:00	.00	.00	.00	.00	.00	.00	.00	.00	.00	.00	.00
09/01/03	13:00	.00	.00	.00	.00	.00	.00	.00	.00	.00	.00	.00
09/01/03	14:00	.00	.00	.00	.00	.00	.00	.00	.00	.00	.00	.00
09/01/03	15:00	.00	.00	.00	.00	.00	.00	.00	.00	.00	.00	.00
09/01/03	16:00	.00	.00	.00	.00	.00	.00	.00	.00	.00	.00	.00
09/01/03	17:00	.00	.00	.00	.00	.00	.00	.00	.00	.00	.00	.00
09/01/03	18:00	.00	.00	.00	.00	.00	.00	.00	.00	.00	.00	.00
09/01/03	19:00	.00	.00	.00	.00	.00	.00	.00	.00	.00	.00	.00
09/01/03	20:00	.00	.00	.00	.00	.00	.00	.00	.00	.00	.00	.00
09/01/03	21:00	.00	.00	.00	.00	.00	.00	.00	.00	.00	.00	.00
09/01/03	22:00	.00	.00	.00	.00	.00	.00	.00	.00	.00	.00	.00
09/01/03	23:00	.00	.00	.00	.00	.00	.00	.00	.00	.00	.00	.00

Max .00  
 Min .00  
 Mean .00  
 Records 240

Status : 'C' - Less than ## Data, 'P' - Power Fail, 'D' - Disabled, 'T' - Out-of-Control, 'E' - Boiler Off-Line,  
 Flags : 'B' - Bad Status, 'C' - Calibration, 'M' - Maintenance, 'O' - Analog Overrange, 'U' - Analog Underrange,  
 'A' - Arithmetic Error, '+' - Maximum, '-' - Minimum, 'R' - Rate of Change, 'H' - High-High Alarm,  
 'L' - Low-Low Alarm, 'h' - High Alarm, 'l' - Low Alarm, 'J' - High Rate of Change, 'j' - Low Rate of Change,  
 'V' - DIS #1 Obs, 'W' - DIS #2 Obs, 'X' - DIS #3 Obs, 'Y' - DIS #4 Obs, 'Z' - DIS #5 Obs.

Current Date 08/30/03  
 Current Time 00:27

Daily Data Report - Hourly Averages  
 Wheelabrator Ridge Energy  
 08/29/03

Logger Id : 01

Logger Name : Ridge Energy

Interval : 001H

Param :	TIREFEED	O2WET	STKFLOW	MGWATTS	FTEMP	STMPFLOW	CO#/HR	NO#/HR	SO2#/HR
Units :	KPPH	VOL%	KSCFM	MW	DEG_F	KPPH	#/HR	#/HR	#/HR
Stack :									
Unit :									
Hour	Blr1	Blr1	Blr1	Blr1	Blr1	Blr1	Blr1	Blr1	Blr1
00	.0	13.7	184	11.1	2305	98.5	95.40	64.27	2.74
01	.0	14.0	184	11.3	2284	95.1	165.31	62.80	7.78
02	.0	14.0	185	11.9	2321	101.0	93.25	62.83	7.56
03	.0	15.3	180	8.4	2273	69.4	336.75	53.15	5.23
04	.0	13.8	183	11.4	2313	97.3	150.16	62.37	6.69
05	.0	13.4	189	14.1	2324	117.3	66.39	65.97	9.19
06	.0	13.8	198	13.0	2311	108.8	94.68	58.49	8.11
07	.0	13.7	209	14.0	2329	114.7	84.55	66.36	28.45
08	.0	13.6	200	12.8	2332	104.3	120.92	63.73	16.58
09	.3	12.9	199C	15.0	2336	122.2	51.69C	67.16C	36.38C
10	6.5	11.1C	220	25.7	2296	203.6	240.29C	79.73C	61.81C
11	18.9	11.4	246	35.0	2236	270.7	597.12	80.78	75.05
12	21.1	10.6	245	35.1	2237	275.4	357.09	93.22	250.07
13	25.2	10.5	250	38.8	2264	300.7	349.56	99.22	115.92
14	24.9	9.9	252	39.5	2273	306.5	522.33	93.17	93.58
15	29.0	9.5	251	40.7	2275	320.0	648.32	88.06	106.62
16	26.3	10.3	251	40.1	2241	318.4	331.25	108.23	140.30
17	26.3	12.0	248	33.5	2191	263.0	237.85	97.20	129.76
18	24.0	14.1	239	19.9	2257	156.8	235.37	96.30	113.19
19	19.7	12.1	247	30.2	2252	237.3	240.31	111.87	132.87
20	23.7	10.3	252	38.9	2267	304.4	639.31	105.01	136.50
21	29.2	10.7	252	39.6	2248	312.5	185.25	127.97	162.49
22	17.0	12.4C	213	15.9	2300	122.8	56.57C	68.83C	20.90C
23	.5	13.6	194	11.1	2320	87.5	120.36	63.20	13.11
Max :	29.2	15.3	252	40.7	2336	320.0	648.32	127.97	250.07
Min :	.0	9.5	180	8.4	2191	69.4	51.69	53.15	2.74
Mean :	12.2	12.4	220	23.6	2283	187.8	250.84	80.83	70.04
Hours :	24	24	24	24	24	24	24	24	24

Status : 'K' - Less than 88% Data, 'P' - Power Fail, 'D' - Disabled, 'T' - Out-of-Control, 'F' - Boiler Off-Line,  
 Flags : 'B' - Bad Status, 'C' - Calibration, 'M' - Maintenance, 'O' - Analog Overrange, 'U' - Analog Underrange,  
 'A' - Arithmetic Error, '+', '-' - Maximum, Minimum, 'R' - Rate of Change, 'H' - High-High Alarm,  
 'L' - Low-Low Alarm, 'h' - High Alarm, 'l' - Low Alarm, 'J' - High Rate of Change, 'j' - Low Rate of Change,  
 'V' - DIS #1 Obs, 'W' - DIS #2 Obs, 'X' - DIS #3 Obs, 'Y' - DIS #4 Obs, 'Z' - DIS #5 Obs

Current Date 08/30/03  
 Current Time 00:35

Daily Parameter Report - Auxiliary Averages  
 Wheelabrator Ridge Energy  
 08/29/03

Logger Name : RIDGE  
 Logger Id : 01

Stack :  
 Boiler/Unit : Opac

Parameter : STAKOPAC  
 Units : PERCENT

Date	Time	Minute									
		00	06	12	18	24	30	36	42	48	54
08/29/03	00:00	.00	.00	.00	.00	.00	.00	.00	.00	.00	.00
08/29/03	01:00	.00	.00	.00	.00	.00	.00	.00	.00	.00	.00
08/29/03	02:00	.00	.00	.00	.00	.00	.00	.00	.00	.00	.00
08/29/03	03:00	.00	.00	.00	.00	.00	.00	.00	.00	.00	.00
08/29/03	04:00	.00	.00	.00	.00	.00	.00	.00	.00	.00	.00
08/29/03	05:00	.00	.00	.00	.00	.00	.00	.00	.00	.00	.00
08/29/03	06:00	.00	.00	.00	.00	.00	.00	.00	.00	.00	.00
08/29/03	07:00	.00	.00	.00	.00	.00	.00	.00	.00	.00	.00
08/29/03	08:00	.00	.00	.00	.00	.00	.00	.00	.00	.00	.00
08/29/03	09:00	.00	.00	.00B	.00B	.00	.00	.00	.00	.00	.00
08/29/03	10:00	.00	.00	.00	.00	.00	.00	.00	.00	.00	.00
08/29/03	11:00	.00	.00	.00	.00	.00	.00	.00	.00	.00	.00
08/29/03	12:00	.00	.00	.00	.00	.00	.00	.00	.00	.00	.00
08/29/03	13:00	.00	.00	.00	.00	.00	.00	.00	.00	.00	.00
08/29/03	14:00	.00	.00	.00	.00	.00	.00	.00	.00	.00	.00
08/29/03	15:00	.00	.00	.00	.00	.00	.00	.00	.00	.00	.00
08/29/03	16:00	.00	.00	.00	.00	.00	.00	.00	.00	.00	.00
08/29/03	17:00	.00	.00	.00	.00	.00	.00	.00	.00	.00	.00
08/29/03	18:00	.00	.00	.00	.00	.00	.00	.00	.00	.00	.00
08/29/03	19:00	.00	.00	.00	.00	.00	.00	.00	.00	.00	.00
08/29/03	20:00	.00	.00	.00	.00	.00	.00	.00	.00	.00	.00
08/29/03	21:00	.00	.00	.00	.00	.00	.00	.00	.00	.00	.00
08/29/03	22:00	.00	.00	.00	.00	.00	.00	.00	.00	.00	.00
08/29/03	23:00	.00	.00	.00	.00	.00	.00	.00	.00	.00	.00

Max .00  
 Min .00  
 Mean .00  
 Records 240

Status : 'C' - Less than ##% Data, 'P' - Power Fail, 'D' - Disabled, 'T' - Out-of-Control, 'F' - Boiler Off-Line,  
 Flags : 'B' - Bad Status, 'C' - Calibration, 'M' - Maintenance, 'O' - Analog Overrange, 'U' - Analog Under-range,  
 'A' - Arithmetic Error, '+' - Maximum, '-' - Minimum, 'R' - Rate of Change, 'H' - High-High Alarm,  
 'L' - Low-Low Alarm, 'h' - High Alarm, 'l' - Low Alarm, 'J' - High Rate of Change, 'j' - Low Rate of Change,  
 '\*V' - DIS #1 Obs, '\*W' - DIS #2 Obs, '\*X' - DIS #3 Obs, '\*Y' - DIS #4 Obs, '\*Z' - DIS #5 Obs.

Current Date 08/26/03  
 Current Time 00:27

Daily Data Report - Hourly Averages  
 Wheelabrator Ridge Energy  
 08/25/03

Logger Id : 01

Logger Name : Ridge Energy

Interval : 001H

Param :	TIREFEED	O2WET	STKFLOW	MGWATTS	FTEMP	STMFLOW	CO#/HR	NO#/HR	SO2#/HR
Units :	KPPH	VOL%	KSCFM	MW	DEG F	KPPH	#/HR	#/HR	#/HR
Stack :									
Unit :		Blr1	Blr1	Blr1	Blr1	Blr1	Blr1	Blr1	Blr1
Hour									
00	.0	12.6	189	15.4	2336	134.6	19.70	68.83	.73
01	.0	12.4	187	15.6	2337	136.7	14.15	68.87	.29
02	.0	12.1	184	15.6	2337	136.5	8.88	65.68	.17
03	.0	13.4	186	12.8	2337	117.3	49.56	60.77	.70
04	.0	14.0	194	11.6	2336	108.8	81.81	67.83	.39
05	.0	12.6	196	15.5	2336	136.5	24.54	70.37	.88
06	.0	13.4	209	14.5	2336	129.4	73.20	75.00	1.09
07	.0	13.6	211	14.0	2336	125.5	95.92	77.01	.78
08	.0	13.3	211	14.9	2336	132.6	111.51	81.79	.40
09	31.8P	13.3P	208P	15.4P	2336P	134.8P	41.58P	84.33P	.18E
10	38.4D	12.4D	229D	25.6D	2336D	205.6D	19.60D	104.03D	18.99D
11	24.2D	10.9C	245	35.4	2328	279.5	227.75C	116.51C	63.56C
12	23.2	10.4	245	38.2	2311	302.1	136.61	120.81	80.78
13	19.8	10.0	245	38.5	2326	304.1	272.79	111.94	60.84
14	21.1	10.2	243	39.3	2299	313.3	189.27	121.14	107.45
15	24.0	10.1	241	40.1	2280	319.1	190.64	122.73	168.48
16	24.7	11.0	241	37.3	2271	296.7	88.54	119.50	177.41
17	30.3	10.0	242	41.3	2255	329.2	170.04	120.71	145.36
18	26.0	9.2	243	40.6	2294	318.4	582.42	91.28	94.81
19	25.3	9.8	241	40.8	2264	322.5	491.90	97.65	143.02
20	30.7	9.8	240	39.7	2304	312.3	430.17	102.49	151.84
21	24.9	10.2	239	38.8	2293	305.7	376.74	99.72	229.11
22	18.3	13.3C	226	17.1	2332	146.0	88.57C	72.55C	24.12C
23	.7	13.8	214	14.3	2336	126.0	144.26	63.23	22.46
Max :	38.4	14.0	245	41.3	2337	329.2	582.42	122.73	229.11
Min :	.0	9.2	184	11.6	2255	108.8	8.88	60.77	.17
Mean :	15.1	11.7	221	26.3	2316	215.6	163.76	91.03	62.24
Hours :	24	24	24	24	24	24	24	24	24

*DOWN TIME*  
*MAINTENANCE*

Status : '<' - Less than ## Data, 'P' - Power Fail, 'D' - Disabled, 'T' - Out-of-Control, 'F' - Boiler Off-Line,  
 Flags : 'B' - Bad Status, 'C' - Calibration, 'M' - Maintenance, 'O' - Analog Overrange, 'U' - Analog Underrange,  
 'A' - Arithmetic Error, '+' - Maximum, '-' - Minimum, 'R' - Rate of Change, 'H' - High-High Alarm,  
 'L' - Low-Low Alarm, 'h' - High Alarm, 'l' - Low Alarm, 'U' - High Rate of Change, 'J' - Low Rate of Change,  
 'V' - DIS #1 Obs, 'W' - DIS #2 Obs, 'X' - DIS #3 Obs, 'Y' - DIS #4 Obs, 'Z' - DIS #5 Obs.

urrent Date : 08/26/03  
 urrent Time : 7:57

Daily Parameter Report - Auxiliary Averages  
 Wheelabrator Ridge Energy

Logger Name : Ridge Energy  
 Logger Id : 01  
 Parameter : STAKOPAC  
 Units : PERCENT

Stack :  
 Boiler/Unit : Opac

Date	Time	Minute										
		00	06	12	18	24	30	36	42	48	54	
8/25/03	00:00	.00	.00	.00	.00	.00	.00	.00	.00	.00	.00	.00
8/25/03	01:00	.00	.00	.00	.00	.00	.00	.00	.00	.00	.00	.00
8/25/03	02:00	.00	.00	.00	.00	.00	.00	.00	.00	.00	.00	.00
8/25/03	03:00	.00	.00	.00	.00	.00	.00	.00	.00	.00	.00	.00
8/25/03	04:00	.00	.00	.00	.00	.00	.00	.00	.00	.00	.00	.00
8/25/03	05:00	.00	.00	.00	.00	.00	.00	.00	.00	.00	.00	.00
8/25/03	06:00	.00	.00	.00	.00	.00	.00	.00	.00	.00	.00	.00
8/25/03	07:00	.00	.00	.00	.00	.00	.00	.00	.00	.00	.00	.00
8/25/03	08:00	.00	.00	.00	.00	.00	.00	.00	.00	.00	.00	.00
8/25/03	09:00	.00	.00	.00B	.00B	.00	.00	.00P	.00	.00D	.00	.00
8/25/03	10:00	.00	.08D	.00	.07D	.00	.00	.00	.00	.00	.00	.00
8/25/03	11:00	.00	.00	.00	.00	.00	.00	.00	.00	.00	.00	.00
8/25/03	12:00	.00	.00	.00	.00	.00	.00	.00	.00	.00	.00	.00
8/25/03	13:00	.00	.00	.00	.00	.00	.00	.00	.00	.00	.00	.00
8/25/03	14:00	.00	.00	.00	.00	.00	.00	.00	.00	.00	.00	.00
8/25/03	15:00	.00	.00	.00	.00	.00	.00	.00	.00	.00	.00	.00
8/25/03	16:00	.00	.00	.00	.00	.00	.00	.00	.00	.00	.00	.00
8/25/03	17:00	.00	.00	.00	.00	.00	.00	.00	.00	.00	.00	.00
8/25/03	18:00	.00	.00	.00	.00	.00	.00	.00	.00	.00	.00	.00
8/25/03	19:00	.00	.00	.00	.00	.00	.00	.00	.00	.00	.00	.00
8/25/03	20:00	.00	.00	.00	.00	.00	.00	.00	.00	.00	.00	.00
8/25/03	21:00	.00	.00	.00	.00	.00	.00	.00	.00	.00	.00	.00
8/25/03	22:00	.00	.00	.00	.00	.00	.00	.00	.00	.00	.00	.00
8/25/03	23:00	.00	.00	.00	.00	.00	.00	.00	.00	.00	.00	.00

Max .08  
 Min .00  
 Mean .00  
 Records 240

Status : 'K' - Less than 88% Data, 'P' - Power Fail, 'D' - Disabled, 'T' - Out-of-Control, 'F' - Boiler Off-Line,  
 'B' - Bad Status, 'C' - Calibration, 'M' - Maintenance, 'O' - Analog Overrange, 'U' - Analog Underrange,  
 'A' - Arithmetic Error, 'X' - Maximum, 'I' - Minimum, 'R' - Rate of Change, 'H' - High-High Alarm,  
 'L' - Low-Low Alarm, 'h' - High Alarm, 'l' - Low Alarm, 'J' - High Rate of Change, 'j' - Low Rate of Change,  
 'V' - DIS #1 Obs, 'W' - DIS #2 Obs, 'X' - DIS #3 Obs, 'Y' - DIS #4 Obs, 'Z' - DIS #5 Obs.

## EMISSIONS UNIT INFORMATION

Section [ 2 ] of [ 3 ]

### III. EMISSIONS UNIT INFORMATION

**Title V Air Operation Permit Application** - For Title V air operation permitting only, emissions units are classified as regulated, unregulated, or insignificant. If this is an application for Title V air operation permit, a separate Emissions Unit Information Section (including subsections A through I as required) must be completed for each regulated and unregulated emissions unit addressed in this application for air permit. Some of the subsections comprising the Emissions Unit Information Section of the form are optional for unregulated emissions units. Each such subsection is appropriately marked. Insignificant emissions units are required to be listed at Section II, Subsection C.

**Air Construction Permit or FESOP Application** - For air construction permitting or federally enforceable state air operation permitting, emissions units are classified as either subject to air permitting or exempt from air permitting. The concept of an "unregulated emissions unit" does not apply. If this is an application for air construction permit or FESOP, a separate Emissions Unit Information Section (including subsections A through I as required) must be completed for each emissions unit subject to air permitting addressed in this application for air permit. Emissions units exempt from air permitting are required to be listed at Section II, Subsection C.

**Air Construction Permit and Revised/Renewal Title V Air Operation Permit Application** - Where this application is used to apply for both an air construction permit and a revised/renewal Title V air operation permit, each emissions unit is classified as either subject to air permitting or exempt from air permitting for air construction permitting purposes and as regulated, unregulated, or insignificant for Title V air operation permitting purposes. **The air construction permitting classification must be used to complete the Emissions Unit Information Section of this application for air permit.** A separate Emissions Unit Information Section (including subsections A through I as required) must be completed for each emissions unit subject to air permitting addressed in this application for air permit. Emissions units exempt from air construction permitting and insignificant emissions units are required to be listed at Section II, Subsection C.

If submitting the application form in hard copy, the number of this Emissions Unit Information Section and the total number of Emissions Unit Information Sections submitted as part of this application must be indicated in the space provided at the top of each page.



**EMISSIONS UNIT INFORMATION**

Section [ 2 ] of [ 3 ]

**A. GENERAL EMISSIONS UNIT INFORMATION**

**Title V Air Operation Permit Emissions Unit Classification**

1. Regulated or Unregulated Emissions Unit? (Check one, if applying for an initial, revised or renewal Title V air operation permit. Skip this item if applying for an air construction permit or FESOP only.)

The emissions unit addressed in this Emissions Unit Information Section is a regulated emissions unit.

The emissions unit addressed in this Emissions Unit Information Section is an unregulated emissions unit.

**Emissions Unit Description and Status**

1. Type of Emissions Unit Addressed in this Section: (Check one)

This Emissions Unit Information Section addresses, as a single emissions unit, a single process or production unit, or activity, which produces one or more air pollutants and which has at least one definable emission point (stack or vent).

This Emissions Unit Information Section addresses, as a single emissions unit, a group of process or production units and activities which has at least one definable emission point (stack or vent) but may also produce fugitive emissions.

This Emissions Unit Information Section addresses, as a single emissions unit, one or more process or production units and activities which produce fugitive emissions only.

2. Description of Emissions Unit Addressed in this Section: **Ash Handling System**

3. Emissions Unit Identification Number: **002**

4. Emissions Unit Status Code: <b>A</b>	5. Commence Construction Date: <b></b>	6. Initial Startup Date: <b>3/94</b>	7. Emissions Unit Major Group SIC Code: <b>49</b>	8. Acid Rain Unit? <input type="checkbox"/> Yes <input checked="" type="checkbox"/> No
--	---	---	--	--

9. Package Unit:  
Manufacturer: \_\_\_\_\_ Model Number: \_\_\_\_\_

10. Generator Nameplate Rating: **MW**

11. Emissions Unit Comment: **Bottom as is removed using wet drag conveyors. The wetting of the bottom ash minimizes fugitive dust emissions. Solid waste from sifting hoppers, economizer hoppers, SDA hoppers, and fabric filter hoppers are removed by a combination of screw conveyors and or drag conveyors.**

**EMISSIONS UNIT INFORMATION**

Section [ 2 ] of [ 3 ]

**Emissions Unit Control Equipment**

1. Control Equipment/Method(s) Description:  
**Wet Scrubber**

2. Control Device or Method Code(s): **141**

**EMISSIONS UNIT INFORMATION**

Section [2] of [3]

**B. EMISSIONS UNIT CAPACITY INFORMATION**

(Optional for unregulated emissions units.)

**Emissions Unit Operating Capacity and Schedule**

1. Maximum Process or Throughput Rate: <b>25,000 lb/hr</b>
2. Maximum Production Rate: <b>NA</b>
3. Maximum Heat Input Rate: <b>million Btu/hr NA</b>
4. Maximum Incineration Rate: <b>pounds/hr</b> <b>tons/day</b>
5. Requested Maximum Operating Schedule: <b>24 hours/day</b> <b>7 days/week</b> <b>52 weeks/year</b> <b>8,760 hours/year</b>
6. Operating Capacity/Schedule Comment: The Ash Handling System scrubber operates continuously. However, on a weekly basis, the scrubber is down for maintenance as required for optimal efficiency. The downtime is usually 4-6 hours. On occasions, the scrubber is down due to malfunctions. During the period when the scrubber is down, water is sprayed on the ash inside the ash building to minimize fugitive emissions.

**EMISSIONS UNIT INFORMATION**

Section [2] of [3]

**C. EMISSION POINT (STACK/VENT) INFORMATION****(Optional for unregulated emissions units.)****Emission Point Description and Type**

1. Identification of Point on Plot Plan or Flow Diagram: <b>ID No. 2</b>		2. Emission Point Type Code: <b>1</b>	
3. Descriptions of Emission Points Comprising this Emissions Unit for VE Tracking: <b>NA</b>			
4. ID Numbers or Descriptions of Emission Units with this Emission Point in Common: <b>NA</b>			
5. Discharge Type Code: <b>P</b>	6. Stack Height: feet <b>NA</b>		7. Exit Diameter: feet <b>NA</b>
8. Exit Temperature: °F <b>Ambient</b>	9. Actual Volumetric Flow Rate: acfm <b>NA</b>	10. Water Vapor: % <b>NA</b>	
11. Maximum Dry Standard Flow Rate: dscfm		12. Nonstack Emission Point Height: feet <b>15</b>	
13. Emission Point UTM Coordinates... Zone: East (km): North (km):		14. Emission Point Latitude/Longitude... Latitude (DD/MM/SS) Longitude (DD/MM/SS)	
15. Emission Point Comment:			

**EMISSIONS UNIT INFORMATION**

Section [ 2 ] of [ 3 ]

**D. SEGMENT (PROCESS/FUEL) INFORMATION**

**Segment Description and Rate:** Segment 1 of 1

1. Segment Description (Process/Fuel Type): <b>Ash loadout area</b>		
2. Source Classification Code (SCC): <b>30183</b>		3. SCC Units: <b>Tons</b>
4. Maximum Hourly Rate: <b>12.5</b>	5. Maximum Annual Rate: <b>109,500</b>	6. Estimated Annual Activity Factor: <b>NA</b>
7. Maximum % Sulfur: <b>NA</b>	8. Maximum % Ash: <b>NA</b>	9. Million Btu per SCC Unit: <b>NA</b>
10. Segment Comment: <b>For informational purposes only.</b>		

**Segment Description and Rate:** Segment    of   

1. Segment Description (Process/Fuel Type):		
2. Source Classification Code (SCC):		3. SCC Units:
4. Maximum Hourly Rate:	5. Maximum Annual Rate:	6. Estimated Annual Activity Factor:
7. Maximum % Sulfur:	8. Maximum % Ash:	9. Million Btu per SCC Unit:
10. Segment Comment:		

**EMISSIONS UNIT INFORMATION**

Section [ 2 ] of [ 3 ]

**D. SEGMENT (PROCESS/FUEL) INFORMATION (CONTINUED)**

**Segment Description and Rate:** Segment \_\_ of \_\_

1. Segment Description (Process/Fuel Type):		
2. Source Classification Code (SCC):		3. SCC Units:
4. Maximum Hourly Rate:	5. Maximum Annual Rate:	6. Estimated Annual Activity Factor:
7. Maximum % Sulfur:	8. Maximum % Ash:	9. Million Btu per SCC Unit:
10. Segment Comment:		

**Segment Description and Rate:** Segment \_\_ of \_\_

1. Segment Description (Process/Fuel Type):		
2. Source Classification Code (SCC):		3. SCC Units:
4. Maximum Hourly Rate:	5. Maximum Annual Rate:	6. Estimated Annual Activity Factor:
7. Maximum % Sulfur:	8. Maximum % Ash:	9. Million Btu per SCC Unit:
10. Segment Comment:		







**F2. EMISSIONS UNIT POLLUTANT DETAIL INFORMATION -  
 ALLOWABLE EMISSIONS**

**Complete if the pollutant identified in Subsection F1 is or would be subject to a numerical emissions limitation.**

**Allowable Emissions** Allowable Emissions \_\_ of \_\_

1. Basis for Allowable Emissions Code:	2. Future Effective Date of Allowable Emissions:
3. Allowable Emissions and Units:	4. Equivalent Allowable Emissions: lb/hour                      tons/year
5. Method of Compliance:	
6. Allowable Emissions Comment (Description of Operating Method):	

**Allowable Emissions** Allowable Emissions \_\_ of \_\_

1. Basis for Allowable Emissions Code:	2. Future Effective Date of Allowable Emissions:
3. Allowable Emissions and Units:	4. Equivalent Allowable Emissions: lb/hour                      tons/year
5. Method of Compliance:	
6. Allowable Emissions Comment (Description of Operating Method):	

**Allowable Emissions** Allowable Emissions \_\_ of \_\_

1. Basis for Allowable Emissions Code:	2. Future Effective Date of Allowable Emissions:
3. Allowable Emissions and Units:	4. Equivalent Allowable Emissions: lb/hour                      tons/year
5. Method of Compliance:	
6. Allowable Emissions Comment (Description of Operating Method):	



**EMISSIONS UNIT INFORMATION**

Section [ 2 ] of [ 3 ]

**H. CONTINUOUS MONITOR INFORMATION**

Complete if this emissions unit is or would be subject to continuous monitoring.

**Continuous Monitoring System:** Continuous Monitor \_\_\_ of \_\_\_

1. Parameter Code:	2. Pollutant(s):
3. CMS Requirement:	<input type="checkbox"/> Rule <input type="checkbox"/> Other
4. Monitor Information... Manufacturer: Model Number: Serial Number:	
5. Installation Date:	6. Performance Specification Test Date:
7. Continuous Monitor Comment:	

**Continuous Monitoring System:** Continuous Monitor \_\_\_ of \_\_\_

1. Parameter Code:	2. Pollutant(s):
3. CMS Requirement:	<input type="checkbox"/> Rule <input type="checkbox"/> Other
4. Monitor Information... Manufacturer: Model Number: Serial Number:	
5. Installation Date:	6. Performance Specification Test Date:
7. Continuous Monitor Comment:	

**EMISSIONS UNIT INFORMATION**

Section [ 2 ] of [ 3 ]

**H. CONTINUOUS MONITOR INFORMATION (CONTINUED)**

Complete if this emissions unit is or would be subject to continuous monitoring.

**Continuous Monitoring System:** Continuous Monitor \_\_\_ of \_\_\_

1. Parameter Code:	2. Pollutant(s):
3. CMS Requirement:	<input type="checkbox"/> Rule <input type="checkbox"/> Other
4. Monitor Information... Manufacturer: Model Number: Serial Number:	
5. Installation Date:	6. Performance Specification Test Date:
7. Continuous Monitor Comment:	

**Continuous Monitoring System:** Continuous Monitor \_\_\_ of \_\_\_

1. Parameter Code:	2. Pollutant(s):
3. CMS Requirement:	<input type="checkbox"/> Rule <input type="checkbox"/> Other
4. Monitor Information... Manufacturer: Model Number: Serial Number:	
5. Installation Date:	6. Performance Specification Test Date:
7. Continuous Monitor Comment:	

**EMISSIONS UNIT INFORMATION**

Section [ 2 ] of [ 3 ]

**I. EMISSIONS UNIT ADDITIONAL INFORMATION**

**Additional Requirements for All Applications, Except as Otherwise Stated**

1. Process Flow Diagram (Required for all permit applications, except Title V air operation permit revision applications if this information was submitted to the department within the previous five years and would not be altered as a result of the revision being sought) <input type="checkbox"/> Attached, Document ID: _____ <input checked="" type="checkbox"/> Previously Submitted, Date <b>April 21, 2000</b>
2. Fuel Analysis or Specification (Required for all permit applications, except Title V air operation permit revision applications if this information was submitted to the department within the previous five years and would not be altered as a result of the revision being sought) <input type="checkbox"/> Attached, Document ID: _____ <input type="checkbox"/> Previously Submitted, Date _____
3. Detailed Description of Control Equipment (Required for all permit applications, except Title V air operation permit revision applications if this information was submitted to the department within the previous five years and would not be altered as a result of the revision being sought) <input type="checkbox"/> Attached, Document ID: _____ <input type="checkbox"/> Previously Submitted, Date <b>April 21, 2000</b>
4. Procedures for Startup and Shutdown (Required for all operation permit applications, except Title V air operation permit revision applications if this information was submitted to the department within the previous five years and would not be altered as a result of the revision being sought) <input type="checkbox"/> Attached, Document ID: _____ <input type="checkbox"/> Previously Submitted, Date _____ <input checked="" type="checkbox"/> Not Applicable (construction application)
5. Operation and Maintenance Plan (Required for all permit applications, except Title V air operation permit revision applications if this information was submitted to the department within the previous five years and would not be altered as a result of the revision being sought) <input type="checkbox"/> Attached, Document ID: _____ <input type="checkbox"/> Previously Submitted, Date _____ <input checked="" type="checkbox"/> Not Applicable
6. Compliance Demonstration Reports/Records <input checked="" type="checkbox"/> Attached, Document ID: <b>RGS-F1-C4</b> Test Date(s)/Pollutant(s) Tested: <b>2003, VE</b> _____ <input type="checkbox"/> Previously Submitted, Date: _____ Test Date(s)/Pollutant(s) Tested: _____ <input type="checkbox"/> To be Submitted, Date (if known): _____ Test Date(s)/Pollutant(s) Tested: _____ <input type="checkbox"/> Not Applicable  Note: For FESOP applications, all required compliance demonstration records/reports must be submitted at the time of application. For Title V air operation permit applications, all required compliance demonstration reports/records must be submitted at the time of application, or a compliance plan must be submitted at the time of application.
7. Other Information Required by Rule or Statute <input type="checkbox"/> Attached, Document ID: _____ <input checked="" type="checkbox"/> Not Applicable

**EMISSIONS UNIT INFORMATION**

Section [ 2 ] of [ 3 ]

**Additional Requirements for Air Construction Permit Applications**

1. Control Technology Review and Analysis (Rules 62-212.400(6) and 62-212.500(7), F.A.C.; 40 CFR 63.43(d) and (e)) <input type="checkbox"/> Attached, Document ID: _____ <input checked="" type="checkbox"/> Not Applicable
2. Good Engineering Practice Stack Height Analysis (Rule 62-212.400(5)(h)6., F.A.C., and Rule 62-212.500(4)(f), F.A.C.) <input type="checkbox"/> Attached, Document ID: _____ <input checked="" type="checkbox"/> Not Applicable
3. Description of Stack Sampling Facilities (Required for proposed new stack sampling facilities only) <input type="checkbox"/> Attached, Document ID: _____ <input checked="" type="checkbox"/> Not Applicable

**Additional Requirements for Title V Air Operation Permit Applications**

1. Identification of Applicable Requirements <input checked="" type="checkbox"/> Attached, Document ID: <u>RGS-EU1-I6</u>
2. Compliance Assurance Monitoring <input type="checkbox"/> Attached, Document ID: _____ <input checked="" type="checkbox"/> Not Applicable
3. Alternative Methods of Operation <input type="checkbox"/> Attached, Document ID: _____ <input checked="" type="checkbox"/> Not Applicable
4. Alternative Modes of Operation (Emissions Trading) <input type="checkbox"/> Attached, Document ID: _____ <input checked="" type="checkbox"/> Not Applicable



## EMISSIONS UNIT INFORMATION

Section [3] of [3]

### III. EMISSIONS UNIT INFORMATION

**Title V Air Operation Permit Application** - For Title V air operation permitting only, emissions units are classified as regulated, unregulated, or insignificant. If this is an application for Title V air operation permit, a separate Emissions Unit Information Section (including subsections A through I as required) must be completed for each regulated and unregulated emissions unit addressed in this application for air permit. Some of the subsections comprising the Emissions Unit Information Section of the form are optional for unregulated emissions units. Each such subsection is appropriately marked. Insignificant emissions units are required to be listed at Section II, Subsection C.

**Air Construction Permit or FESOP Application** - For air construction permitting or federally enforceable state air operation permitting, emissions units are classified as either subject to air permitting or exempt from air permitting. The concept of an "unregulated emissions unit" does not apply. If this is an application for air construction permit or FESOP, a separate Emissions Unit Information Section (including subsections A through I as required) must be completed for each emissions unit subject to air permitting addressed in this application for air permit. Emissions units exempt from air permitting are required to be listed at Section II, Subsection C.

**Air Construction Permit and Revised/Renewal Title V Air Operation Permit Application** - Where this application is used to apply for both an air construction permit and a revised/renewal Title V air operation permit, each emissions unit is classified as either subject to air permitting or exempt from air permitting for air construction permitting purposes and as regulated, unregulated, or insignificant for Title V air operation permitting purposes. **The air construction permitting classification must be used to complete the Emissions Unit Information Section of this application for air permit.** A separate Emissions Unit Information Section (including subsections A through I as required) must be completed for each emissions unit subject to air permitting addressed in this application for air permit. Emissions units exempt from air construction permitting and insignificant emissions units are required to be listed at Section II, Subsection C.

If submitting the application form in hard copy, the number of this Emissions Unit Information Section and the total number of Emissions Unit Information Sections submitted as part of this application must be indicated in the space provided at the top of each page.



**EMISSIONS UNIT INFORMATION**

Section [3] of [3]

**A. GENERAL EMISSIONS UNIT INFORMATION**

**Title V Air Operation Permit Emissions Unit Classification**

1. Regulated or Unregulated Emissions Unit? (Check one, if applying for an initial, revised or renewal Title V air operation permit. Skip this item if applying for an air construction permit or FESOP only.)

- The emissions unit addressed in this Emissions Unit Information Section is a regulated emissions unit.
- The emissions unit addressed in this Emissions Unit Information Section is an unregulated emissions unit.

**Emissions Unit Description and Status**

1. Type of Emissions Unit Addressed in this Section: (Check one)

- This Emissions Unit Information Section addresses, as a single emissions unit, a single process or production unit, or activity, which produces one or more air pollutants and which has at least one definable emission point (stack or vent).
- This Emissions Unit Information Section addresses, as a single emissions unit, a group of process or production units and activities which has at least one definable emission point (stack or vent) but may also produce fugitive emissions.
- This Emissions Unit Information Section addresses, as a single emissions unit, one or more process or production units and activities which produce fugitive emissions only.

2. Description of Emissions Unit Addressed in this Section: **Lime silo**

3. Emissions Unit Identification Number: **003**

4. Emissions Unit Status Code: <b>A</b>	5. Commence Construction Date: <b></b>	6. Initial Startup Date: <b>03/94</b>	7. Emissions Unit Major Group SIC Code: <b>49</b>	8. Acid Rain Unit? <input type="checkbox"/> Yes <input checked="" type="checkbox"/> No
--	---	--	--	--

9. Package Unit:  
Manufacturer: \_\_\_\_\_ Model Number: \_\_\_\_\_

10. Generator Nameplate Rating: **MW**

11. Emissions Unit Comment: **lime is fed from the lime silo into a slaker to form a high solids slurry. Lime slurry is then used in the spray dryer absorber.**

**EMISSIONS UNIT INFORMATION**

Section [ 3 ] of [ 3 ]

**Emissions Unit Control Equipment**

1. Control Equipment/Method(s) Description:  
**Bin vent filter for particulate control**

2. Control Device or Method Code(s): **018**



**EMISSIONS UNIT INFORMATION**

Section [ 3 ] of [ 3 ]

**C. EMISSION POINT (STACK/VENT) INFORMATION**  
**(Optional for unregulated emissions units.)**

**Emission Point Description and Type**

1. Identification of Point on Plot Plan or Flow Diagram: <b>ID No. 5</b>		2. Emission Point Type Code:	
3. Descriptions of Emission Points Comprising this Emissions Unit for VE Tracking: NA			
4. ID Numbers or Descriptions of Emission Units with this Emission Point in Common: NA			
5. Discharge Type Code: <b>P</b>	6. Stack Height: feet <b>NA</b>		7. Exit Diameter: feet <b>NA</b>
8. Exit Temperature: °F <b>Ambient</b>	9. Actual Volumetric Flow Rate: acfm <b>NA</b>	10. Water Vapor: % <b>NA</b>	
11. Maximum Dry Standard Flow Rate: dscfm		12. Nonstack Emission Point Height: feet <b>83</b>	
13. Emission Point UTM Coordinates... Zone: East (km): North (km):		14. Emission Point Latitude/Longitude... Latitude (DD/MM/SS) Longitude (DD/MM/SS)	
15. Emission Point Comment:			

**EMISSIONS UNIT INFORMATION**

Section [3] of [3]

**D. SEGMENT (PROCESS/FUEL) INFORMATION**

**Segment Description and Rate:** Segment 1 of 1

1. Segment Description (Process/Fuel Type): <b>Lime storage in lime silo</b>		
2. Source Classification Code (SCC): <b>30183001</b>		3. SCC Units: <b>Tons lime</b>
4. Maximum Hourly Rate: <b>25</b>	5. Maximum Annual Rate: <b>219,000</b>	6. Estimated Annual Activity Factor: <b>NA</b>
7. Maximum % Sulfur: <b>NA</b>	8. Maximum % Ash: <b>NA</b>	9. Million Btu per SCC Unit: <b>NA</b>
10. Segment Comment: <b>For informational purposes only</b>		

**Segment Description and Rate:** Segment    of   

1. Segment Description (Process/Fuel Type):		
2. Source Classification Code (SCC):		3. SCC Units:
4. Maximum Hourly Rate:	5. Maximum Annual Rate:	6. Estimated Annual Activity Factor:
7. Maximum % Sulfur:	8. Maximum % Ash:	9. Million Btu per SCC Unit:
10. Segment Comment:		

**EMISSIONS UNIT INFORMATION**

Section [ 3 ] of [ 3 ]

**D. SEGMENT (PROCESS/FUEL) INFORMATION (CONTINUED)**

**Segment Description and Rate:** Segment \_\_ of \_\_

1. Segment Description (Process/Fuel Type):		
2. Source Classification Code (SCC):		3. SCC Units:
4. Maximum Hourly Rate:	5. Maximum Annual Rate:	6. Estimated Annual Activity Factor:
7. Maximum % Sulfur:	8. Maximum % Ash:	9. Million Btu per SCC Unit:
10. Segment Comment:		

**Segment Description and Rate:** Segment \_\_ of \_\_

1. Segment Description (Process/Fuel Type):		
2. Source Classification Code (SCC):		3. SCC Units:
4. Maximum Hourly Rate:	5. Maximum Annual Rate:	6. Estimated Annual Activity Factor:
7. Maximum % Sulfur:	8. Maximum % Ash:	9. Million Btu per SCC Unit:
10. Segment Comment:		







**F2. EMISSIONS UNIT POLLUTANT DETAIL INFORMATION -  
 ALLOWABLE EMISSIONS**

**Complete if the pollutant identified in Subsection F1 is or would be subject to a numerical emissions limitation.**

**Allowable Emissions** Allowable Emissions \_\_ of \_\_

1. Basis for Allowable Emissions Code:	2. Future Effective Date of Allowable Emissions:
3. Allowable Emissions and Units:	4. Equivalent Allowable Emissions: lb/hour                      tons/year
5. Method of Compliance:	
6. Allowable Emissions Comment (Description of Operating Method):	

**Allowable Emissions** Allowable Emissions \_\_ of \_\_

1. Basis for Allowable Emissions Code:	2. Future Effective Date of Allowable Emissions:
3. Allowable Emissions and Units:	4. Equivalent Allowable Emissions: lb/hour                      tons/year
5. Method of Compliance:	
6. Allowable Emissions Comment (Description of Operating Method):	

**Allowable Emissions** Allowable Emissions \_\_ of \_\_

1. Basis for Allowable Emissions Code:	2. Future Effective Date of Allowable Emissions:
3. Allowable Emissions and Units:	4. Equivalent Allowable Emissions: lb/hour                      tons/year
5. Method of Compliance:	
6. Allowable Emissions Comment (Description of Operating Method):	

**EMISSIONS UNIT INFORMATION**

Section [3] of [3]

**G. VISIBLE EMISSIONS INFORMATION**

Complete if this emissions unit is or would be subject to a unit-specific visible emissions limitation.

**Visible Emissions Limitation:** Visible Emissions Limitation 1 of 1

1. Visible Emissions Subtype: <b>VE10</b>	2. Basis for Allowable Opacity: <input checked="" type="checkbox"/> Rule <input type="checkbox"/> Other
3. Allowable Opacity: Normal Conditions: <b>10 %</b> Exceptional Conditions: % Maximum Period of Excess Opacity Allowed: min/hour	
4. Method of Compliance: <b>EPA Method 9; Annual test</b>	
5. Visible Emissions Comment: <b>Permit Limit; Title V Permit No. 1050216-001-AV</b>	

**Visible Emissions Limitation:** Visible Emissions Limitation \_\_\_ of \_\_\_

1. Visible Emissions Subtype:	2. Basis for Allowable Opacity: <input type="checkbox"/> Rule <input type="checkbox"/> Other
3. Allowable Opacity: Normal Conditions: % Exceptional Conditions: % Maximum Period of Excess Opacity Allowed: min/hour	
4. Method of Compliance:	
5. Visible Emissions Comment:	

**EMISSIONS UNIT INFORMATION**

Section [ 3 ] of [ 3 ]

**H. CONTINUOUS MONITOR INFORMATION**

**Complete if this emissions unit is or would be subject to continuous monitoring.**

**Continuous Monitoring System:** Continuous Monitor \_\_\_ of \_\_\_

1. Parameter Code:	2. Pollutant(s):
3. CMS Requirement:	<input type="checkbox"/> Rule <input type="checkbox"/> Other
4. Monitor Information... Manufacturer: Model Number: Serial Number:	
5. Installation Date:	6. Performance Specification Test Date:
7. Continuous Monitor Comment:	

**Continuous Monitoring System:** Continuous Monitor \_\_\_ of \_\_\_

1. Parameter Code:	2. Pollutant(s):
3. CMS Requirement:	<input type="checkbox"/> Rule <input type="checkbox"/> Other
4. Monitor Information... Manufacturer: Model Number: Serial Number:	
5. Installation Date:	6. Performance Specification Test Date:
7. Continuous Monitor Comment:	

**EMISSIONS UNIT INFORMATION**

Section [ 3 ] of [ 3 ]

**H. CONTINUOUS MONITOR INFORMATION (CONTINUED)**

**Complete if this emissions unit is or would be subject to continuous monitoring.**

**Continuous Monitoring System:** Continuous Monitor \_\_\_ of \_\_\_

1. Parameter Code:	2. Pollutant(s):
3. CMS Requirement:	<input type="checkbox"/> Rule <input type="checkbox"/> Other
4. Monitor Information... Manufacturer: Model Number:	Serial Number:
5. Installation Date:	6. Performance Specification Test Date:
7. Continuous Monitor Comment:	

**Continuous Monitoring System:** Continuous Monitor \_\_\_ of \_\_\_

1. Parameter Code:	2. Pollutant(s):
3. CMS Requirement:	<input type="checkbox"/> Rule <input type="checkbox"/> Other
4. Monitor Information... Manufacturer: Model Number:	Serial Number:
5. Installation Date:	6. Performance Specification Test Date:
7. Continuous Monitor Comment:	

**EMISSIONS UNIT INFORMATION**

Section [ 3 ] of [ 3 ]

**I. EMISSIONS UNIT ADDITIONAL INFORMATION**

**Additional Requirements for All Applications, Except as Otherwise Stated**

1. Process Flow Diagram (Required for all permit applications, except Title V air operation permit revision applications if this information was submitted to the department within the previous five years and would not be altered as a result of the revision being sought) <input checked="" type="checkbox"/> Attached, Document ID: <u>RGS-EU3-I1</u> <input type="checkbox"/> Previously Submitted, Date _____
2. Fuel Analysis or Specification (Required for all permit applications, except Title V air operation permit revision applications if this information was submitted to the department within the previous five years and would not be altered as a result of the revision being sought) <input type="checkbox"/> Attached, Document ID: _____ <input type="checkbox"/> Previously Submitted, Date _____
3. Detailed Description of Control Equipment (Required for all permit applications, except Title V air operation permit revision applications if this information was submitted to the department within the previous five years and would not be altered as a result of the revision being sought) <input checked="" type="checkbox"/> Attached, Document ID: <u>RGS-EU3-I3</u> <input type="checkbox"/> Previously Submitted, Date _____
4. Procedures for Startup and Shutdown (Required for all operation permit applications, except Title V air operation permit revision applications if this information was submitted to the department within the previous five years and would not be altered as a result of the revision being sought) <input checked="" type="checkbox"/> Attached, Document ID: <u>RGS-EU3-I3</u> <input type="checkbox"/> Previously Submitted, Date _____ <input type="checkbox"/> Not Applicable (construction application)
5. Operation and Maintenance Plan (Required for all permit applications, except Title V air operation permit revision applications if this information was submitted to the department within the previous five years and would not be altered as a result of the revision being sought) <input checked="" type="checkbox"/> Attached, Document ID: <u>RGS-EU3-I3</u> <input type="checkbox"/> Previously Submitted, Date _____ <input type="checkbox"/> Not Applicable
6. Compliance Demonstration Reports/Records <input checked="" type="checkbox"/> Attached, Document ID: <u>RGS-F1-C4</u> Test Date(s)/Pollutant(s) Tested: <u>2003, VE</u> _____ <input type="checkbox"/> Previously Submitted, Date: _____ Test Date(s)/Pollutant(s) Tested: _____ <input type="checkbox"/> To be Submitted, Date (if known): _____ Test Date(s)/Pollutant(s) Tested: _____ <input type="checkbox"/> Not Applicable  Note: For FESOP applications, all required compliance demonstration records/reports must be submitted at the time of application. For Title V air operation permit applications, all required compliance demonstration reports/records must be submitted at the time of application, or a compliance plan must be submitted at the time of application.
7. Other Information Required by Rule or Statute <input type="checkbox"/> Attached, Document ID: _____ <input checked="" type="checkbox"/> Not Applicable

**EMISSIONS UNIT INFORMATION**

Section [ 3 ] of [ 3 ]

**Additional Requirements for Air Construction Permit Applications**

1. Control Technology Review and Analysis (Rules 62-212.400(6) and 62-212.500(7), F.A.C.; 40 CFR 63.43(d) and (e)) <input type="checkbox"/> Attached, Document ID: _____ <input checked="" type="checkbox"/> Not Applicable
2. Good Engineering Practice Stack Height Analysis (Rule 62-212.400(5)(h)6., F.A.C., and Rule 62-212.500(4)(f), F.A.C.) <input type="checkbox"/> Attached, Document ID: _____ <input checked="" type="checkbox"/> Not Applicable
3. Description of Stack Sampling Facilities (Required for proposed new stack sampling facilities only) <input type="checkbox"/> Attached, Document ID: _____ <input checked="" type="checkbox"/> Not Applicable

**Additional Requirements for Title V Air Operation Permit Applications**

1. Identification of Applicable Requirements <input checked="" type="checkbox"/> Attached, Document ID: <u><b>RGS-EU1-I6</b></u>
2. Compliance Assurance Monitoring <input type="checkbox"/> Attached, Document ID: _____ <input checked="" type="checkbox"/> Not Applicable
3. Alternative Methods of Operation <input type="checkbox"/> Attached, Document ID: _____ <input checked="" type="checkbox"/> Not Applicable
4. Alternative Modes of Operation (Emissions Trading) <input type="checkbox"/> Attached, Document ID: _____ <input checked="" type="checkbox"/> Not Applicable

5. Acid Rain Part Application

- Certificate of Representation (EPA Form No. 7610-1)
  - Copy Attached, Document ID: \_\_\_\_\_
- Acid Rain Part (Form No. 62-210.900(1)(a))
  - Attached, Document ID: \_\_\_\_\_
  - Previously Submitted, Date: \_\_\_\_\_
- Repowering Extension Plan (Form No. 62-210.900(1)(a)1.)
  - Attached, Document ID: \_\_\_\_\_
  - Previously Submitted, Date: \_\_\_\_\_
- New Unit Exemption (Form No. 62-210.900(1)(a)2.)
  - Attached, Document ID: \_\_\_\_\_
  - Previously Submitted, Date: \_\_\_\_\_
- Retired Unit Exemption (Form No. 62-210.900(1)(a)3.)
  - Attached, Document ID: \_\_\_\_\_
  - Previously Submitted, Date: \_\_\_\_\_
- Phase II NOx Compliance Plan (Form No. 62-210.900(1)(a)4.)
  - Attached, Document ID: \_\_\_\_\_
  - Previously Submitted, Date: \_\_\_\_\_
- Phase II NOx Averaging Plan (Form No. 62-210.900(1)(a)5.)
  - Attached, Document ID: \_\_\_\_\_
  - Previously Submitted, Date: \_\_\_\_\_
- Not Applicable

**Additional Requirements Comment**

**ATTACHMENT RGS-EU3-I1**  
**Process Flow Diagram**  
**Lime Silo**



ATTACHMENT RGS-EU3-I1

Process Flow Diagram

Lime Silo

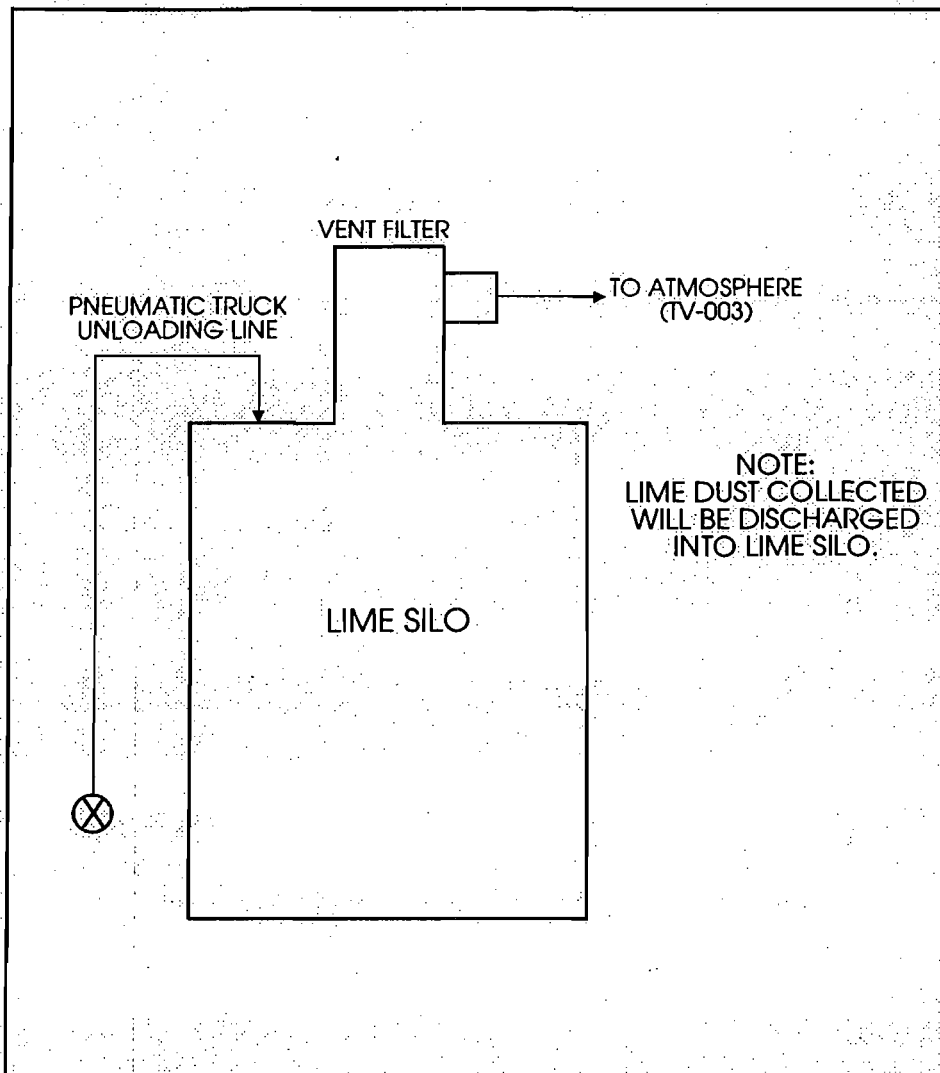

**ATTACHEMENT RGS-EU3-I3**

Description of Control Equipment

Startup Shutdown Procedures

Lime Silo Vent Filter

## OPERATION AND SERVICE MANUAL

**EQUIPMENT:** One (1) #22 WCC Model 36  
Bin Vent Dust Collector

**CUSTOMER:** Wheelabrator Air Pollution Control

**SERIAL NO:** 20-3342

**CUSTOMER'S  
ORDER NO:** 06 3682 014

**DATE OF ISSUE:** June 1993

**NOTE:**

The entire contents of this manual, including drawings and technical brochures, is the property of Wheelabrator Canada Inc., and shall not be disclosed, duplicated, in whole or in part, to any third party for any purpose whatsoever, other than to maintain the equipment as described herein.

Head Office Fax #: 416-875-1675  
Head Office Tel #: 416-875-1662

Montreal Office Fax #: 514-465-3285  
Montreal Office Tel #: 514-465-3280

401 Wheelabrator Way,  
Milton, Ontario L9T 4B7

8 Place du Commerce, Suite 150  
Brossard, Quebec J4W 3H2

# WHEELABRATOR CARTRIDGE COLLECTOR

## TABLE OF CONTENTS

- 1** WHEELABRATOR CARTRIDGE COLLECTOR (WCC)
- 2** THEORY OF OPERATION
- 3** FILTER ELEMENT INSTALLATION
- 4** PRECOMMISSIONING START-UP AND SHUT DOWN
- 5** TROUBLE SHOOTING
- 6** PULSE CLEANING SYSTEM COMPONENTS
  - Pressure Gauge
  - Timer
  - Internals
  - Solenoid Valves
  - Recommended Air Piping

# SECTION I

## WHEELABRATOR CARTRIDGE COLLECTOR

### PULSE TYPE DUST COLLECTOR

The information and drawings contained in this manual have been issued to help in the proper erection and inspection as well as to provide a reference for ordering repair parts as needed.

We recommend that you familiarize yourself with the drawings and pamphlets listed in the Table of Contents. This material has been included to aid in the proper maintenance, operation and servicing of this collector. With the proper care and maintenance, your machine will provide maximum performance and long service.

#### A. PACKING LIST

A Packing List, covering all parts shipped, will be found attached to, or placed inside one of the shipping crates.

#### B. GENERAL

This collector is used for the dry filtration of the particulates suspended in an air stream. Particulates are collected on the outside of the cartridges as the air stream passes through them.

The accumulation of solids, on the cartridges, increases the resistance to flow, i.e. "Differential Pressure", necessitating filter element cleaning by a "Compressed Air Jet Pump Cleaning Device".

The Wheelabrator Cartridge Collector ordered under this contract is one of the most efficient Dust Collectors available. This system uses controlled blast of compressed air to operate the filter element cleaning system.

The dust laden air passes through the elements outside to the inside, depositing the particulates on the outside surfaces of the element. At intervals set by a timer, bursts of compressed air are released in the reverse direction to the flow, creating a backwash effect. As soon as the cleaning energy is spent, the elements return to normal filtering, and the dust that has just been pulsed off, falls into the collector hopper.

## SECTION 2

### THEORY OF OPERATION

The Wheelabrator Cartridge Collector is a continuous automatic, suction or pressure type Dust Collector capable of filtering dust laden air through a porous filter media.

The dirty or contaminated air enters the dust collector through the module inlet, the air is distributed uniformly throughout the housing and heavy particulate drops out into the hopper. The dust laden air then passes through a number of filter elements which retain the dust particles on the exterior surface while allowing the clean air to pass through to the module outlet.

As the collector operates, the collected dust begins to form a dust cake on the filter element which diminishes the ability of the filter element to pass air. This increased resistance is measured by a U-Tube manometer or pressure gauge and is defined as the differential pressure. As the differential pressure increases, the system pressure loss will increase, decreasing the ventilation volume.

To maintain the correct pressure drop, a cleaning cycle is employed to provide continuous cleaning of the filter element. This is accomplished by a timer which energizes electric solenoids activating the diaphragm valves. The diaphragm valves deliver a momentary pulse of compressed air through the manifold pipe and into the venturics. The venturics, which act as natural jet pumps, induce secondary air several times the original volume. This creates a reverse air flow through the filters, providing efficient cleaning.

This cleaning process occurs on a row by row basis, thus, only a fraction of the total filter air is interrupted for cleaning, allowing continuous ventilation.

The dust cake when pulsed from the filter elements falls directly into the hopper where it is removed.

## SECTION 3

### FILTER ELEMENT INSTALLATION

1. Make sure that the cartridge clamping beams are positioned so that they are in the lowest position.
2. Check filter elements to ensure that they are not damaged in any manner and that the gaskets are secured at the top of the element and not damaged.
3. Slide an element with top plate onto the locating slide rails and push into the collector until the element stops. Repeat this procedure by sliding appropriate number of elements (3 or 4) until the row is complete.
4. Alignment of filters to venturi is automatically accomplished by the self-aligning cap tops once all elements are in their respective rows.
5. Slowly push down a single lever handle until the lever locks into place. Repeat procedure on the adjacent lever. The element seal is now properly compressed.
6. Close maintenance access doors tightly to obtain a good seal.

#### NOTES:

- The filter element head gasket must be compressed to prevent leakage.
- Proper storage of filter elements is essential in maintaining maximum collecting efficiency of your Air Pollution Control Unit.
- Store filters in the boxes in which they were shipped in a cool, dry place (preferably on pallets covered with plastic), in a warehouse, (where mould and physical damage to the crates will not occur).

## SECTION 4

### PRECOMMISSIONING START-UP AND SHUT DOWN WHEELABRATOR CARTRIDGE COLLECTORS

The following should be checked and corrected before introducing dust laden air into the filter:

1. Inspect the interior of the hopper to ensure that the discharge area is completely free of debris and unwanted materials.
2. Check filter elements for proper fit against the tubesheet.
3. Make sure that the filter element locking lever is in the correct position and the element gasket is securely compressed against the tubesheet. (Note that the housing doors will not shut unless the filter element locking lever is in the correct position).
4. Ensure that the access doors are properly secured and sealed.
5. Open the compressed air header drain plugs and slowly crack open compressed air to header system. When the header discharge is free of visible moisture, close the drain plugs. Set the compressed air pressure at 80 to 90 p.s.i.g.
6. Energize the electronic timer board and adjust for approximately five (5) minutes repeat cycle firing sequence (i.e. each row activated 12 times per hour). Observe signal lights until all terminals have been fired. (See timer schematic wiring diagram if trouble occurs).
7. With timer operating as described and air header charged, check "audibly" for the energizing of all air valves. These are positioned on the air header. The "normally closed" diaphragm (air valves) will open only on being signalled by the timer via the pilot solenoid valves. The sudden release to atmosphere of compressed air from the "bleed hole" of each pilot valve will prove the air valves are being opened as required.
8. Check and ensure that hopper discharge equipment is properly operating. Hopper must not be used for storage.



SECTION 4

PRECOMMISSIONING, START-UP  
Continued

9. Check to ensure the collector is fitted with a "U"-Tube manometer or magnetic differential pressure gauge. The gauge should have a zero reading prior to starting the fan. Be sure lines are clean and connections tight.
10. Check the drive system for the exhaust fan (i.e., tensioning of V-belts; proper alignment of sheaves) and ensure hold down bolts are tightened properly. Refer to Fan Operation (Auxiliary Section).
11. Test start (bump) the exhaust fan motor and ensure proper rotation of the fan wheel.
12. Start mechanical dust handling system. Screw conveyor(s) and/or rotary air lock valves.
13. Start the exhaust fan under throttled conditions to ensure design volume is not exceeded.

NOTE: On process systems such as dryers, coolers or dry process where water vapour or other condensibles are present, it is necessary to preheat the system so that the module skin temperature of the complete dust control system is above the dew point temperatures. Instrumentation should be adjusted to maintain the gas temperature above the dew point of the condensibles and below the maximum limit of the filter media.

14. Note and record the manometer reading. The system should be allowed to operate in the "throttled" position until the manometer reading reaches 4" to 5" W.G.
15. At this point, start the pulse cleaning system. The timer off-time should be adjusted for one (1) minute pulse frequency and should be increased or decreased if the differential pressure begins to climb or fall.
16. Slowly, and in small increments, open the fan damper if applicable. Observe differential pressure reading for the effect on resistance. Increase or decrease the timer setting to pulse as required to maintain a manometer reading between 4" and 5" W.G.

17. Continue over the next few hours to open the fan damper until design volume is reached or adequate ventilation levels have been attained at the dust control hoods.
18. With the collector operating at design volume, the pulse frequency should ideally be set for the fewest pulses/minute while holding the pressure differential across the filter at a stable condition above 3" W.G.

NOTE: Stabilization differential pressure recordings between 1" and 6" can be considered normal. During some instances, the differential pressure may creep beyond 6" W.G. due to surge grain loadings, moisture in air, etc. This can also be considered normal, providing the differential pressure can be regained after the surge.

For prolonged periods of work stoppage when the system is not required to handle dust laden air it is recommended that the timer be shut down. This will prevent over cleaning of the filter.

THE COLLECTOR IS NOW READY FOR OPERATION

## SECTION 5

### TROUBLE SHOOTING

#### 1.0 VISIBLE STACK EMISSIONS

##### 1.1 Improperly Installed Filters

- Check and make sure all gaskets are compressed against the tubesheet
- Check to ensure that venturi lip is located inside cartridge.
- Check to ensure that the locking levers are fully located in the downward position.

##### 1.2 Torn or Punctured Filters

- Inspect filters for tears or punctures caused by mechanical damage, abrasion, thermal or chemical attack. Replace filters as and where required.

##### 1.3 Dirty / Clean Air Plenum

- After filter failure or sometimes during routine filter change-outs, dust can accumulate in dead air zones on the clean air side of the unit.
- Always clean the tubesheet when dust accumulation is present.

#### 2.0 HIGH DIFFERENTIAL PRESSURE

##### 2.1 Over Volume

- Check fan and motor speeds and V-belt drive ratio.
- Reset fan damper or fan speed to handle collector design volume.

##### 2.2 System Resistance Static is too low

- Re-calculate ductwork design to ensure proper static losses. If too low, reduce fan speed or add system resistance with balancing dampers.

**SECTION 5** continued

- 2.3 **Plugged Manometer**
- Check and clean out if lines are plugged.
- 2.4 **Lack of Compressed Air**
- Check pulsing system for compressed air leakage and seal as required.
  - Check compressor output to ensure it exceeds pulse cleaning system usage. Add extra volume as required.
  - Compressed air pressure too low - increase line pressure from regulator - compressor. (Not to exceed 90 p.s.i.).
  - Check clogged feed lines for oil, water, rust or debris.
- 2.5 **Malfunctioning Timer**
- Check timer outputs to ensure all terminals are firing. If timer is faulty, return to Wheelabrator for repair.
  - On some systems, all the channels may not be used. A faulty channel may be bypassed and a spare channel used in this case.
- 2.6 **Dust Re-entrainment**
- Check dust removal system for worn or faulty seals. Repair or replace as required.
  - Check mating flanges - apply gasketing and/or tighten fasteners as required.
  - Dust disposal system plugged or jammed - clean and check disposal system for capacity. Speed up system, install vibrators or enlarge hopper opening as required.
  - Check baffle for abrasion and wear.
- HOPPER MUST NOT BE USED FOR STORAGE.**
- 2.7 **Dust on Clean Air Side**
- Check tubesheet floor and clean as necessary to prevent dust from entering cartridges from clean air side.
  - Check inside of filters for dust and empty as required. Dust in filters will cause stack emissions on a cycle synchronized with pulse blasts.

## SECTION 5 continued

### 2.8 Filter Blinding

- Check system so that oil or free moisture is not entering the filters either from the process or the compressed air system.
- Check fan to ensure collector was started under *throttled* conditions. Extra high speed impingement of fine particles on new media can permanently blind filter media.

### 3.0 INADEQUATE SYSTEM VOLUME

#### 3.1 Fan Rotating Backwards

- Check rotation of fan and correct if necessary.

#### 3.2 High Differential Pressure

See Section 2

#### 3.3 Fan RPM Too Low

- Check drive ratio between fan and motor. Check drive for slippage - retighten or replace as required.
- Fan damper improperly adjusted. Check damper position and adjust to maintain collector design volumes.

#### 3.4 Leakage in System

- Check all ducting and flanges to and from collector for leaks. Re-gasket and tighten fasteners as required.

#### 3.5 System Resistance Static Too High

- Re-calculate ductwork design to ensure proper static losses. If too high, increase fan speed or lower system resistance by changing ductwork and/or hoods.
- Check ductwork for material build-up or blockages. Clean and re-design if necessary.

## SECTION 5 continued

- 3.6 **Blinded Filters**
- Inspect filter elements for possible blinding.
  - Blinded filters usually result in high differential pressure. Clean with fan off until differential pressure drops off. If differential pressure is still high, install new cartridges.
- 3.7 **Fugitive Air Entrainment**
- Check all doors and cover plates for proper sealing.
  - Check all ductwork flanges for airtight seals. Apply gasketing or re-tighten fasteners.
- 4.0 **LOW COMPRESSED AIR AT HEADER**
- 4.1 **Sticking Solenoid Valves**
- Check solenoid plungers for dirt. Clean or replace as required.
  - Short circuit in wiring may cause one or more solenoids to remain open - check wiring and repair or replace as required.
- 4.2 **Pulse Time is Too Long**
- The "Pulse Time" is factory preset and sealed at 100 m/s elect. time maximum. If this has been tampered with, set back to original setting of 100 m/s.
- 4.3 **Sticking Diaphragm Valves**
- Check for torn or damaged diaphragms.
- 4.4 **Debris in Diaphragm Valves**
- Check for dirt, desiccant, oil or ice on diaphragm. Clean or replace as required. If oil, water or ice is present, repair or install dryer on compressed air system to eliminate.
- 4.5 **Leaks in Compressed Air Piping**
- Inspect compressed air lines run for leaks and seal.

## SECTION 5 continued

- 4.6 **Insufficient Supply of Compressed Air**
  - Check capacity of air compressor to ensure proper sizing. See Detail of order to determine demand of unit. Also check for undersized branch-lines in compressed air run.
- 4.7 **Header/Air Valve Connection is Faulty**
  - Inspect connection and repair as required.
- 5.0 **FILTER ELEMENT PROBLEMS (Poor Life, Blinding, etc.)**
- 5.1 **Check system operating temperature against filter media rating**
  - Lower temperature of system or refurbish with media suitable to higher temperatures encountered.
- 5.2 **Check system physical and chemical characteristics against filter media rating**
  - Adjust system gas stream or install new media compatible with gas stream.
- 5.3 **Check abrasion patterns on collector walls, baffles etc.**
- 5.4 **Check material build-up in hopper**
  - Inspect dust disposal equipment for proper operation. Repair as required.
  - Check for hopper bridging.
  - Install vibrators, rapper, etc. or enlarge discharge opening.
- 5.5 **Incorrectly installed Filter Elements**
  - Check for proper seating of filters to tubesheet.
- 5.6 **Dirty / Clean Air Plenum**
  - Inspect tubesheet floor for dust accumulations. Dust on tubesheet floor can be entrained into inside filters by cleaning system. This can cause blinding or abrasion by impregnating filters from the reverse direction.

## SECTION 6

### PULSE CLEANING SYSTEM COMPONENTS

#### 1.0 PRESSURE GAUGE

##### 1.1 Manometers

###### Pressure Sensing U-Tube Manometers

- The effectiveness of the dust collector is monitored by manometers. The manometer compares the air pressure on the dirty air section of the dust collector with the pressure on the clean side. There is one manometer for each compartment. These simple gauges are very useful for applications where the pressure to be measured can vary either way about zero. They can be used for differential measurements or referred to atmospheric pressure (i.e. single-ended).

The instruments are intended for wall or panel mounting, and they are supplied with standard 1/4 in compression joints for pressure lines. If preferred, short lengths of rigid tubing can be fitted in the compression couplings so that the instrument can be connected with flexible push-on tubing.

The instrument body is an aluminum extrusion, incorporating a groove which supports the sight glass along its entire length. The sight glass is held by the bow-front anodised aluminum scale, and fine adjustment for zero is achieved by altering the height of the reservoir tank with the aid of a rotary screwed collar on one of the pressure tappings.

###### Manometer Fluid

- Most of the instruments use paraffin, carefully blended from several grades to a relative density of 0.784 at 20 degrees C. This fluid has several advantages over water, primary among these being the excellent wetting and draining characteristics. This provides a remarkably clean and free-moving meniscus, especially important with sensitive inclined manometers. Other advantages are the expanded scale due to the low relative density, and freedom from tube staining and alterations in density which can be caused by growth of algae in water filled instruments. The water is dyed red.



**SECTION 6 continued**

**Safety**

- Manometer should not be cleaned or fluid changed unless the compartment or unit is shut down or valved off.  
Ensure installation of manometer is not in the direct sunlight.  
Sheltered and shielded area must be selected.

**1.2 Magnehelic Gauge (Optional)**

- Refer to Dwyer Bulletin A-27

**1.3 Pressure Switch (Optional)**

- Refer to Dwyer Bulletin E-57

**1.4 Pressure Gauge Connections**

- Refer to Drawing No. 88C8225

**2.0 TIMER**

- Refer to Wheelabrator Cartridge Collector Timer Operating Instructions.  
(Note: 10 Channel Timer is illustrated. Smaller unit sizes use a 5 Channel Timer)

**3.0 INTERNALS**

- Refer to illustration.

**3.1 Wheelabrator Cartridge Collector Locking Mechanism**

- Refer to illustration.

**4.0 SOLENOID VALVES**

- Refer to Drawing No. 76C8003

**5.0 RECOMMENDED AIR PIPING**

- Refer to Drawing No. 83C8095

# LOCKING OF CARTRIDGES

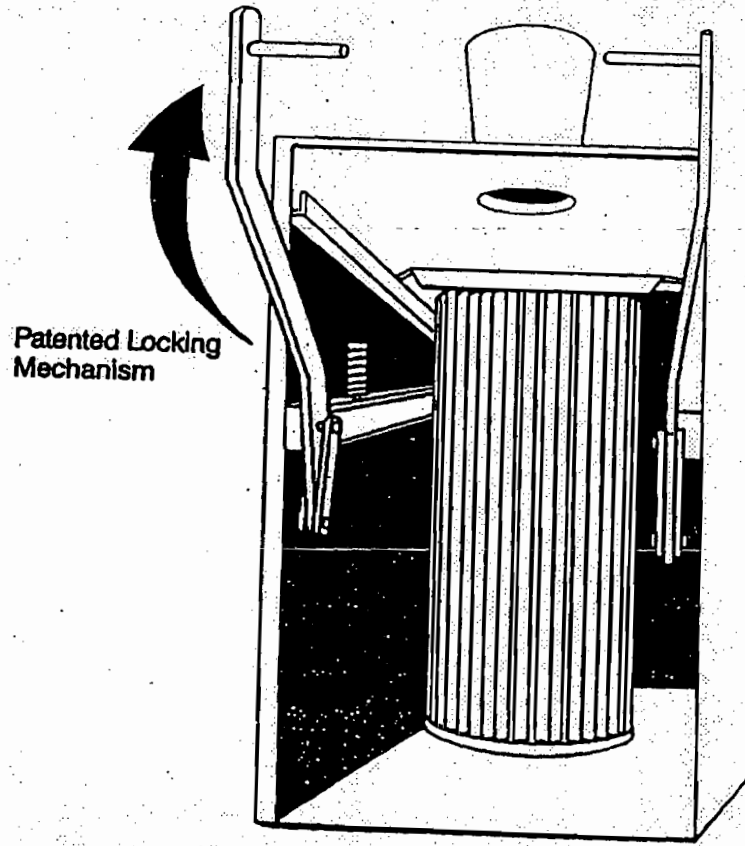

Patented Locking Mechanism

UNLOCKED

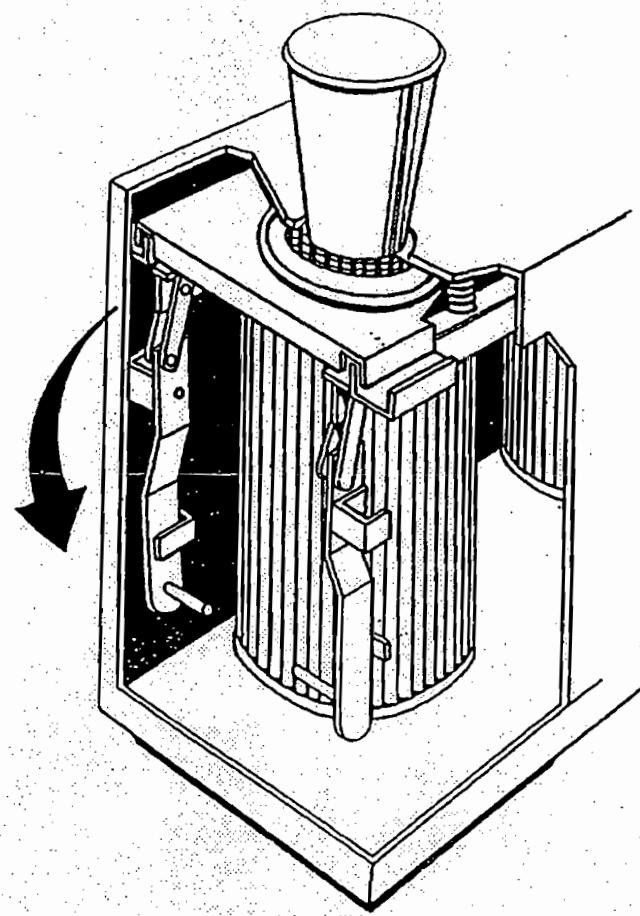

LOCKED

# COLLECTOR COMPONENTS

SOLENOID VALVES

DIAPHRAGM VALVE

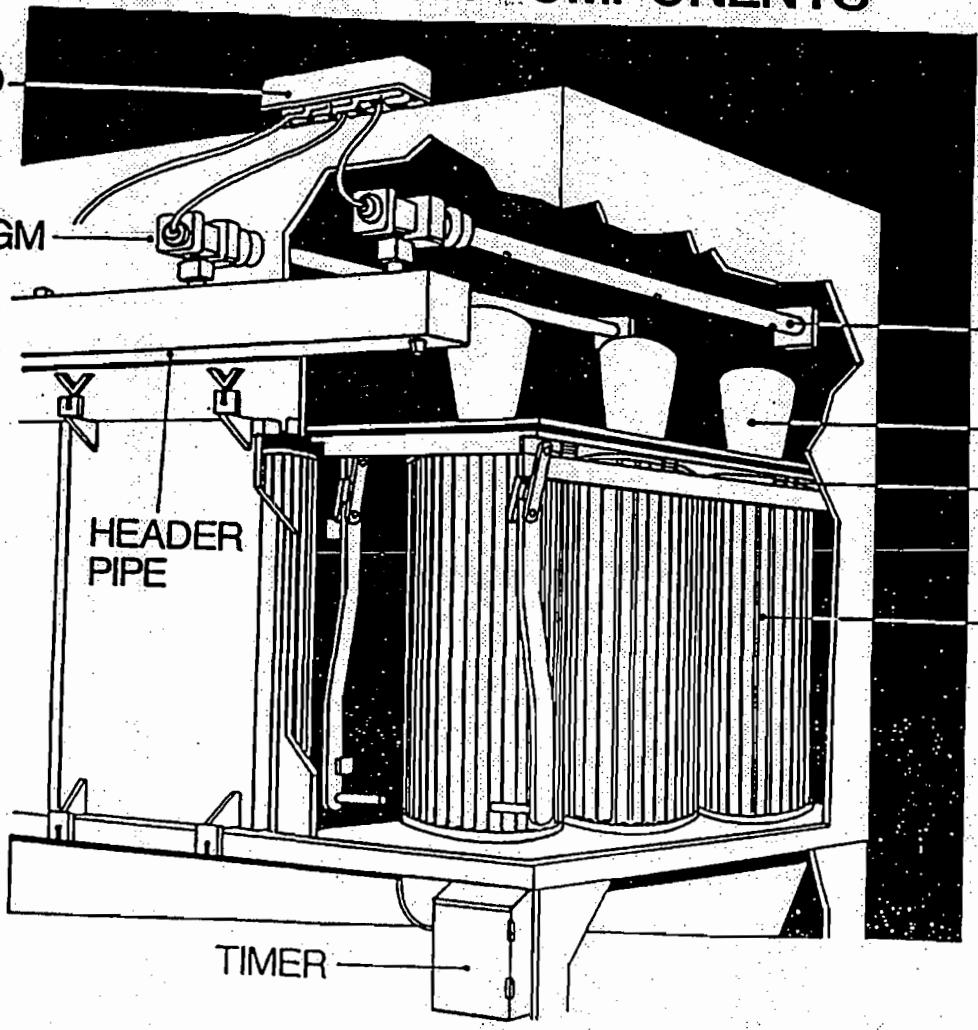

BLOW PIPE

VENTURI

SPRING

HEADER PIPE

FILTER ELEMENT

TIMER