

West County Agency of Contra Costa County  
WASTE CO-DISPOSAL/ENERGY RECOVERY PROJECT

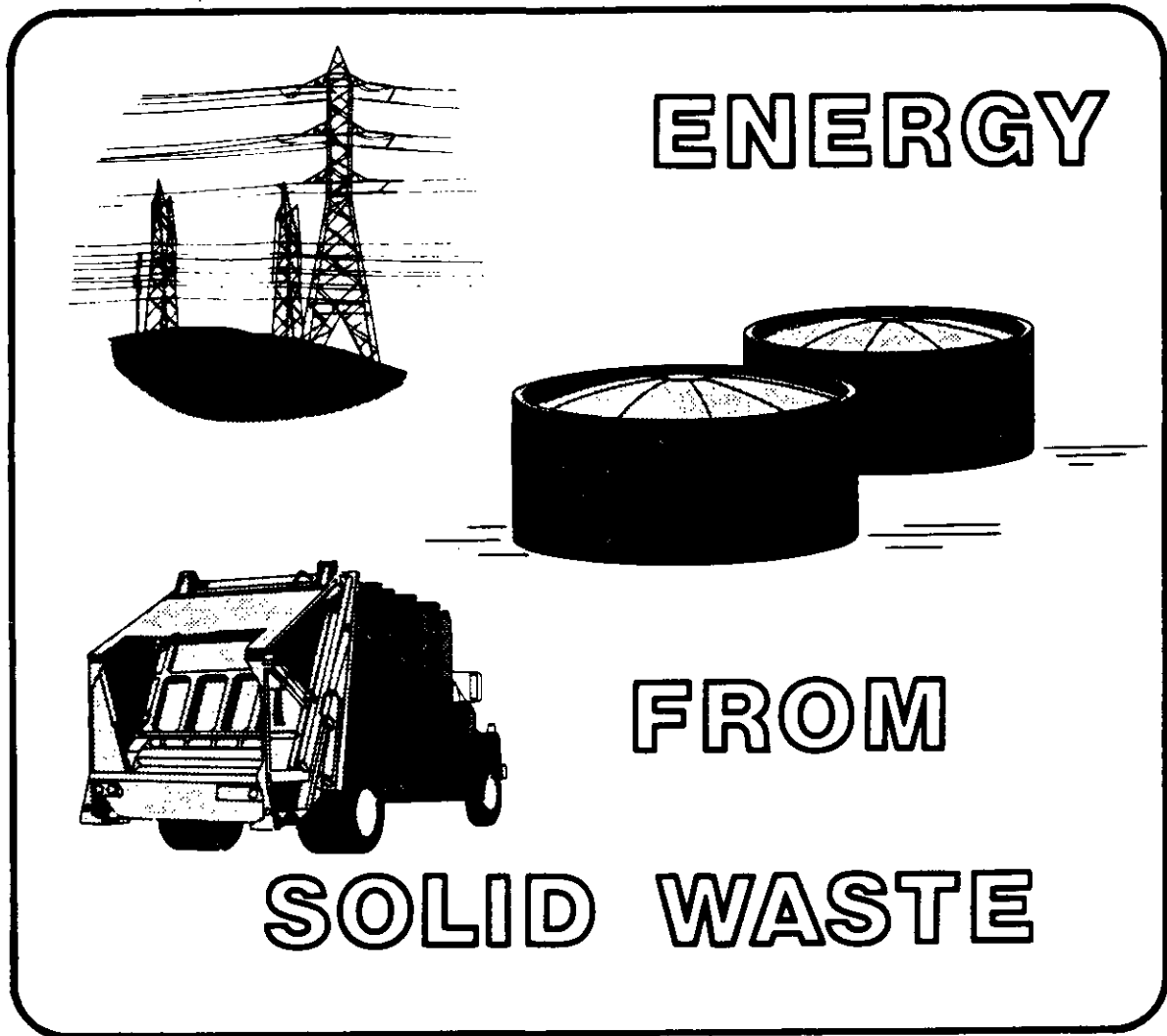

AIR EMISSIONS TESTS OF SOLID WASTE COMBUSTION  
IN A ROTARY COMBUSTOR/BOILER SYSTEM  
AT GALLATIN, TENNESSEE

DER

MAR 5 1986

Prepared by  
BAQM COOPER ENGINEERS, INC., Consulting Engineers

WEST COUNTY AGENCY OF CONTRA COSTA COUNTY  
WASTE CO-DISPOSAL/ENERGY RECOVERY PROJECT

AIR EMISSIONS TESTS OF  
SOLID WASTE COMBUSTION IN A  
ROTARY COMBUSTOR/BOILER SYSTEM  
AT GALLATIN, TENNESSEE

Prepared By

Cooper Engineers, Inc.  
1301 Canal Boulevard  
Richmond, California 94804  
(415) 235-2360

July, 1984

## DISCLAIMER

This document was prepared with financial assistance provided by the California Waste Management Board (Contract No. S936-400 LG). The opinions, findings, conclusions, or recommendations contained herein are those of the authors and do not necessarily reflect the view of the participating state agencies. The mention of commercial products, their source, or their use in connection with material reported herein is not to be construed as either an actual or implied endorsement of such products.

## ACKNOWLEDGEMENT

Acknowledgement is given to Doug Strauch, Mark White, Gerry White, and the late Army Polansky of the California Waste Management Board; Daryl Mills and George Lew of the California Air Resources Board; Chadwell O'Connor, Glen Swinehart, John Healy and Tom Wetherill of O'Connor Combustor Corporation; Dale McKeand of Global Power; and Tom Stucker of Chemecology Corporation. Special thanks for their cooperation are extended to the Resource Authority in Sumner County - Jerry Metcalf, Plant Manager; Sherman (Pat) Patton, Plant Engineer; and all the shift operators and their assistants during the two weeks of testing.

## TABLE OF CONTENTS

	<u>Page</u>
<b>SECTION 1: Introduction and Scope of Work</b>	
A. Introduction .....	1
B. Scope of Work	
1. Original California Waste Management Board Scope of Work .....	1
2. Primary Objectives of the Gallatin Air Emissions Testing .....	2
3. California Air Resources Board Review of Scope of Work .....	2
4. Final Testing Protocol.....	4
<b>SECTION 2: Summary of Air Emissions Test Results</b>	
A. Test Arrangements .....	6
B. Development of Testing Methodology .....	6
C. Regulated Air Pollutants .....	6
D. Non-Regulated Air Pollutants .....	8
E. Heavy Metal Emissions.....	8
F. Solid Waste and Combustion Residue Characteristics.....	11
<b>SECTION 3: Description of the Gallatin Rotary Combustor Facility</b>	
A. General Description .....	12
B. Waste Receiving and Storage Area.....	12
C. Waste Combustion System .....	12
D. Air Pollution Control System .....	14
E. Materials Recovery System .....	14
F. Operation of the Rotary Combustor .....	15
1. Original Design of Automatic Combustion Control System .....	18
2. Changes to ACC System .....	18
3. ACC System During Testing .....	20
<b>SECTION 4: Air Emissions Testing Methodology</b>	
A. Purpose .....	31
B. Final Testing Schedule .....	31
C. Sampling Locations.....	36
D. Sampling Methods .....	36
<b>SECTION 5: Air Emissions Test Data and Emission Factors</b>	
A. Solid Waste	
1. Feed Rate.....	45
2. Fuel Sampling Schedule .....	47
3. Fuel Sample Analyses .....	47
4. Feed Rate During Air Emissions Sampling .....	47

TABLE OF CONTENTS  
continued....

	<u>Page</u>
<b>SECTION 5: Air Emissions Test Data and Emission Factors (Cont.)</b>	
B. Residue .....	52
C. Operation of Rotary Combustor	
1. Operating Schedule .....	57
2. Net Heat Input .....	57
3. Weight Reduction for the Rotary Combustor .....	57
4. Process Data .....	57
D. Flue Gas Data	
1. Flue Gas Flow Rate .....	62
2. O <sub>2</sub> and CO <sub>2</sub> .....	62
3. U.S. EPA F-Factors .....	62
E. Particulate	
1. Emission Rate and Emission Factors .....	68
2. Particle Size Distribution .....	68
F. Heavy Metals	
1. Mercury .....	76
2. Other Heavy Metals .....	76
G. Continuous Emissions Monitoring (CEM) Data	
1. CEM Data Recorded and Summarized .....	82
2. Emission Rates and Emission Factors of CO, NO <sub>x</sub> and SO <sub>2</sub> .....	103
3. Emission Factors in lb/10 <sup>6</sup> Btu Using U.S. EPA F-Factors for CO, NO <sub>x</sub> , and SO <sub>2</sub> .....	103
4. Multivariable Regression Analyses of Plant Operating Data and Emissions of CO, NO <sub>x</sub> , and SO <sub>2</sub> by Rigo & Rigo Associates .....	103
H. SO <sub>2</sub> and SO <sub>3</sub> Data Using U.S. EPA Method 8 and Sulfur Balance .....	113
I. Non-Methane Hydrocarbons (NMHC) .....	117
J. HCl .....	119
K. HF .....	119
L. Ammonia .....	124

**APPENDIX**  
(Available through purchase)

- PART 1** Chemecology Test Report
- PART 2** Air Emissions Test Data  
Original Field Data  
CEM Data Sheets  
Sample Blank Data Sheets
- PART 3** "Test Program Observation Waste-To-Energy Plant  
Gallatin, Tennessee", Acurex Corporation; prepared for the  
U. S. EPA Region IX, March, 1983.
- PART 4** Process Data  
Crane Operator's Log  
Process Data Summary Sheets
- PART 5** Multivariable Regression Analyses of Plant Operating Data  
and Emissions of CO, NO<sub>x</sub>, and SO<sub>2</sub>

## LIST OF TABLES

		<u>Page</u>
Table 1-1	Final Testing Protocol .....	5
Table 2-1	Average Unabated Air Emissions Data from the Gallatin Rotary Combustor - "Regulated Air Pollutants" .....	7
Table 2-2	Average Abated Air Emissions Data from the Gallatin Rotary Combustor - "Regulated Air Pollutants" .....	9
Table 2-3	Average Unabated Air Emissions Data from the Gallatin Rotary Combustor - "Non-Regulated Air Pollutants" .....	10
Table 4-1	Air Emissions Testing and Sampling Schedule, Gallatin Rotary Combustor, February 6-21, 1983.....	32
Table 5-1	Average Hourly Solid Waste Feed Rate, February 7-11, 1983, Tons Per Hour and Crane Load Count .....	46
Table 5-2	Solid Waste Sampling Schedule, February 7-11, 1983 .....	48
Table 5-3	Calorific Value, Proximate and Ultimate Analyses of Solid Waste .....	49
Table 5-4	Calorific Value, Proximate and Ultimate Analyses of Unusual Fuel Constituents (Shingles and Blue Photographic Chips) .....	51
Table 5-5	Residue Sampling Schedule, February 7-11, 1983.....	53
Table 5-6	Calorific Value, Proximate and Ultimate Analyses of Residue .....	54
Table 5-7	Residue Collection, February 7-11, 1983.....	56
Table 5-8	Combustor Operating Schedule, February 7-21, 1983 and Continuous Emissions Monitoring (CEM) Hours of Operation .....	58
Table 5-9	Average Net MSW Heat Input Rate .....	60
Table 5-10	Average Solid Waste Weight Reduction, February 7-11, 1983 .....	61
Table 5-11	Velocities, Flow Rates and Duct Temperatures/Pressures .....	63
Table 5-12	Flowrates Corrected to CEM and Orsat Oxygen .....	64
Table 5-13	Flowrates Based on U.S. EPA F-Factors .....	65
Table 5-14	Comparison of Oxygen and Carbon Dioxide Readings Taken During Sampling by Orsat and CEM.....	66
Table 5-15	Particulate Loadings.....	69
Table 5-16	Particulate Emission Factors .....	70

LIST OF TABLES  
continued ....

		<u>Page</u>
Table 5-17	Particulate Loadings and Particulate Emissions Based on U.S. EPA F-Factors .....	71
Table 5-18	Combustor Outlet Particle Size Distribution by Andersen In-Stack Sampler .....	72
Table 5-19	Combustor Outlet Particle Size Distribution by SoRI Five-Stage Cyclone.....	73
Table 5-20	Apitron Outlet Particle Size Distribution by Andersen In-Stack Sampler .....	74
Table 5-21	Approximate Cyclone and Apitron Removal Efficiency by Particle Size .....	75
Table 5-22	Total Mercury Emissions at the Combustor Outlet .....	77
Table 5-23	Heavy Metal Weight Percentages on Unabated Particulate at Combustor Outlet .....	78
Table 5-24	Unabated (Combustor Outlet) Heavy Metal Emission Rates.....	79
Table 5-25	Heavy Metal Distribution on Particulate.....	81
Table 5-26	CEM Data First Week, Hourly, Typical Conditions .....	83
Table 5-27	CEM Data Second Week, Hourly, Typical Conditions .....	84
Table 5-28	CEM Data First Week, Hourly, Including Unusual Conditions .....	85
Table 5-29	CEM Data Second Week, Hourly, Including Unusual Conditions.....	86
Table 5-30	CEM Data First Week, Daily, Typical Conditions .....	88
Table 5-31	CEM Data Second Week, Daily, Typical Conditions.....	91
Table 5-32	CEM Data First Week, Daily, Including Unusual Conditions.....	94
Table 5-33	CEM Data Second Week, Daily, Including Unusual Conditions.....	97
Table 5-34	CEM Data Summary .....	100
Table 5-35	Emission Factors (lb/ton) for CO, NO <sub>x</sub> , and SO <sub>2</sub> , Calculated from CEM Data Taken During Sampling .....	104
Table 5-36	Emission Factors (lb/10 <sup>6</sup> Btu) for CO, NO <sub>x</sub> , and SO <sub>2</sub> Calculated from CEM Data Taken During Sampling .....	105
Table 5-37	CO Emission Factors Using U.S. EPA F-Factor Calculated from CEM Data Taken During Sampling .....	106



LIST OF TABLES

continued ....

	<u>Page</u>
Table 5-38	NO <sub>x</sub> Emission Factors Using U.S. EPA F-Factor Calculated from CEM Data Taken During Sampling .....107
Table 5-39	SO <sub>2</sub> Emission Factors Using U.S. EPA F-Factor Calculated from CEM Data Taken During Sampling .....108
Table 5-40	NMHC Emission Factors Using U.S. EPA F-Factor Calculated from CEM Data Taken During Sampling .....109
Table 5-41	Emission Factors Using U.S. EPA F- Factor Based on Net Heating Value.....110
Table 5-42	Regression Equations .....112
Table 5-43	SO <sub>2</sub> Emissions and Emission Factors Using U.S. EPA Method 5/8 .....114
Table 5-44	Sulfate Emissions and Emission Factors Using U.S. EPA Method 5/8 .....115
Table 5-45	Sulfur Material Balance .....116
Table 5-46	Non-Methane Hydrocarbons (NMHC) Concentrations, Emission Rates and Emission Factors at the Combustor Outlet, February 7-11, 1983 .....118
Table 5-47	Unabated HCl Emissions and Emission Factors .....119
Table 5-48	Comparison of Kure and Various Gallatin Tests for Total Fluorides; Concentrations of Fluoride in the Particulate and of HF in the Gas Stream of Collection Samples .....121
Table 5-49	Unabated Fluoride Distribution on Particulate.....122
Table 5-50	Unabated Fluoride and HF Emission Rates and Emission Factors at Gallatin and Comparison with Kure Results.....123
Table 5-51	Unabated NH <sub>3</sub> Emissions and Emission Factors .....125
Table 5-52	SO <sub>4</sub> and NH <sub>3</sub> Forms at Combustor Outlet and Apitron Outlet.....126

## LIST OF FIGURES

			<u>Page</u>
Figure 3-1	Photograph	1	Outside of Building .....23
(End of	Photograph	2	Outside of Building .....23
Section 3)	Photograph	3	Dump Pit .....24
	Photograph	4	Feed Hopper .....24
	Photograph	5	Ram Feed System .....25
	Photograph	6	Ram Feed System .....25
	Photograph	7	Control Room .....26
	Photograph	8	Outside of Combustor .....27
	Photograph	9	Inside of Combustor .....27
	Photograph	10	Top of Boiler .....28
	Photograph	11	Bin with Combustion Residue .....29
	Photograph	12	Cyclone/Apitrone .....30
	Photograph	13	Cyclone/Apitrone .....30
Figure 3-2			Cross-section of Gallatin, Tennessee, Facility .....13
Figure 3-3			Air/Gas Flow Schematic .....17
Figure 3-4			Original Gallatin ACC System .....19
Figure 3-5			Modified Gallatin ACC System .....21
Figure 3-6			Steam System Control .....22
Figure 4-1			Cross-Section of Facility Showing Sampling Locations .....37
Figure 4-2			Diagram of Sampling Point 3, GAH Outlet .....38
Figure 4-3			Diagram of Sampling Point 2, Cyclone Outlet .....39
Figure 4-4			Diagram of Sampling Point 1, Main Stack .....40
Figure 4-5			Photograph of Sampling Point 3, GAH Outlet .....41
Figure 4-6			Photograph of Sampling Point 1, Stack .....42

## GUIDE TO ABBREVIATIONS

<b>AAQIAs</b>	<b>Ambient Air Quality Impact Analyses</b>
<b>ACFM</b>	<b>actual cubic feet per minute</b>
<b>ASTM</b>	<b>American Society for Testing Materials</b>
<b>ACC</b>	<b>Automatic Combustion Control</b>
<b>BAAQMD</b>	<b>Bay Area Air Quality Management District</b>
<b>BACT</b>	<b>Best Available Control Technology for Air Pollution Control (California definition, equivalent to U.S. EPA LAER)</b>
<b>Btu</b>	<b>British thermal unit; measure of heat (energy) content of fuel</b>
<b>CARB</b>	<b>California Air Resources Board</b>
<b>CEM</b>	<b>Continuous Emissions Monitoring</b>
<b>CFR</b>	<b>Code of Federal Regulations</b>
<b>CWMB</b>	<b>California Waste Management Board</b>
<b>DOHS</b>	<b>Department of Health Services</b>
<b>FPS</b>	<b>feet per second</b>
<b>GAH</b>	<b>Gas Air Heater</b>
<b>GC</b>	<b>Gas Chromatography</b>
<b>GC/FID</b>	<b>Gas Chromatography With A Flame Ionization Detector</b>
<b>gm/D</b>	<b>grams per day</b>
<b>gr/SDCF</b>	<b>grains per Standard Dry Cubic Foot</b>
<b>HHV</b>	<b>Higher Heating Value</b>
<b>IDF</b>	<b>Induced Draft Fan</b>
<b>IHI</b>	<b>Ishikawajima-Harima Heavy Industries, Ltd.</b>
<b>MSW</b>	<b>Municipal Solid Wastes</b>
<b>NMHC</b>	<b>Non-methane Hydrocarbons</b>
<b>NRT</b>	<b>National Recovery Technologies, Inc.</b>
<b>OFA</b>	<b>Overfire Air</b>
<b>lb/T</b>	<b>pounds of pollutant per ton MSW</b>
<b>lb/hr</b>	<b>pounds of pollutant per hour</b>
<b>lb/10<sup>6</sup>Btu</b>	<b>pounds of pollutant per million Btu of MSW heat input</b>
<b>ppm</b>	<b>parts per million by weight</b>
<b>ppm<sub>dv</sub></b>	<b>parts per million by volume (dry)</b>
<b>ppm<sub>wv</sub></b>	<b>parts per million by volume (wet)</b>

## GUIDE TO ABBREVIATIONS

continued.....

<b>RASCO</b>	<b>Resource Authority in Sumner County</b>
<b>RPM</b>	<b>revolutions per minute</b>
<b>SCAQMD</b>	<b>South Coast Air Quality Management District</b>
<b>SDCF</b>	<b>Standard Dry Cubic Foot of flue or stack gases, 60°F and 29.92" Hg</b>
<b>SDCFM</b>	<b>Standard Dry Cubic Feet per Minute, 60°F and 29.92" Hg</b>
<b>SoRI</b>	<b>Southern Research Institute</b>
<b>STP</b>	<b>Standard Temperature and Pressure, 60°F and 29.92" Hg</b>
<b>SWRCB</b>	<b>State Water Resources Control Board</b>
<b>TPD</b>	<b>tons per day</b>
<b>TPH</b>	<b>tons per hour</b>
<b>U.S. EPA</b>	<b>U.S. Environmental Protection Agency</b>
<b>WCA</b>	<b>West County Agency of Contra Costa County</b>
<b>WCCSD</b>	<b>West Contra Costa Sanitary District</b>

**SECTION 1**

**INTRODUCTION AND SCOPE OF WORK**

**AIR EMISSIONS TESTS OF SOLID WASTE COMBUSTION  
IN A ROTARY COMBUSTOR/BOILER SYSTEM  
AT GALLATIN, TENNESSEE**

**SECTION 1**

**INTRODUCTION AND SCOPE OF WORK**

**A. INTRODUCTION**

During the past six years, the study of feasibility and preliminary design of a plant converting sewage sludge and municipal solid wastes to usable energy have been underway in western Contra Costa County. If feasible, the waste-to-energy project would supply electricity (and possibly steam) from sources other than oil and natural gas-fired equipment.

The concept originated from the intent of the West Contra Costa Sanitary District (WCCSD) to seek lower cost electricity for its wastewater treatment plant and less expensive sludge disposal. After an initial study in 1978, the West County Agency of Contra Costa County (WCA) assumed sponsorship of the project. (The WCA is a joint powers agency of the WCCSD and the City of Richmond Municipal Sewer District.)

The WCA received funds from the California Waste Management Board (CWMB), formerly the State Solid Waste Management Board, to conduct an air emissions test of the Gallatin, Tennessee waste-to-energy facility. Test results from the Gallatin rotary combustor/boiler facility will provide key air emissions data for a similar combustion system proposed for the WCA waste-to-energy plant.

**B. SCOPE OF WORK**

**1. ORIGINAL CALIFORNIA WASTE MANAGEMENT BOARD SCOPE OF WORK:**

The West County Agency received initial funds from a Step I Clean Water Grant from the State Water Resources Control Board (SWRCB) to conduct those activities necessary to determine the feasibility of a sewage sludge co-disposal waste-to-energy project and to do the initial planning for the facility. Additional grants from the SWRCB and the CWMB expanded the scope to include air emissions testing of a rotary combustor/boiler facility in Kure, Japan. The primary objective of that testing was to develop air emission factors that represent the unabated emissions from the combustion of unprocessed municipal solid waste and the abated emissions from an

electrostatic precipitator and a wet scrubber. The results of the test are presented in a 1981 report prepared by Cooper Engineers, formerly Cooper & Clark Consulting Engineers. The additional air emissions tests at Gallatin were funded by a subsequent CWMB grant whose objectives are described below.

2. PRIMARY OBJECTIVES OF THE GALLATIN AIR EMISSIONS TESTING

The primary objective of the Gallatin air emissions testing was to assess the reduction of oxides of nitrogen ( $\text{NO}_x$ ), non-methane hydrocarbon (NMHC) and carbon monoxide (CO) emissions by operating the rotary combustor under automatic combustion control (ACC). This was not assessed at Kure; although that facility did have ACC, it was operated in the manual mode by the City. Ishikawajima-Harima Heavy Industries, Ltd. (IHI), the plant engineers, have successfully operated the Kure facility on the ACC system. Lower  $\text{NO}_x$  and CO emissions by combustion control is a critical factor in obtaining an Authority to Construct and a Permit to Operate from the Bay Area Air Quality Management District (BAAQMD).

Another objective of the testing was to measure unabated acid gas emissions. This information is needed to develop design and operational criteria for the proposed dry scrubber/fabric filter air pollution control equipment selected as best available control technology (BACT) for the WCA project.

Additional test data from Gallatin requested by the regulatory agencies to compare with that obtained at Kure included emissions of total heavy metals and their characterization by particle size ranges. Non-methane hydrocarbons were to be determined on a continuous basis using U.S. Environmental Protection Agency (U.S. EPA) Method 25.

The Gallatin testing also measured the efficiency of the Apitron electrostatically-assisted fabric filter. If proven, this type of particulate control system could be installed in California.

3. CALIFORNIA AIR RESOURCES BOARD REVIEW OF SCOPE OF WORK

The California Air Resources Board (CARB) is the State agency with the responsibility to review the granting of air permits by the regional air quality management and air pollution control districts such as the BAAQMD. Having

this important review capacity, especially regarding the choice of BACT, the scope of work and testing protocol were reviewed by CARB at the request of the CWMB. The following is a synopsis of their comments:

- o Continuous emissions monitors should be used for O<sub>2</sub> in addition to NO<sub>x</sub> and CO.
- o The five-stage, in-stack cyclone sampler (multiclone) designed by Southern Research Institute (SoRI) should be used to measure particle size and collect sufficient particulate in the different size ranges for heavy metal analysis in lieu of using the Andersen cascade impactor.
- o Particle size analyses should include analyses of the following heavy metals: arsenic, beryllium, cadmium, chromium, copper, manganese, molybdenum, nickel, lead, antimony, selenium, tin, vanadium, and zinc.
- o HCl concentrations should be obtained by continuous analyzer, if possible.
- o HF should be sampled by U.S. EPA Method 13B.
- o Low molecular weight and high molecular weight organic compounds should be identified.
- o Mercury should be tested using U.S. EPA Method 101.

Most of CARB's recommendations were incorporated in the final testing protocol which is described in Subsection 1.B.4. The significant differences were: that a continuous HCl analyzer, although available at the Kure facility, was unavailable in this country; that fluoride analysis by particle size and in the gaseous state was substituted for U.S. EPA Method 13B; and that separate analyses of trace organic compounds was too expensive for this program, either analyzed under this grant or analyzed separately by CARB with sampling performed under this grant.



4. FINAL TESTING PROTOCOL

Table 1-1 shows the final testing protocol that was taken to Gallatin having been approved by CWMB and CARB. This testing protocol only differs from the actual testing schedule described in Table 4-1 as to the sequence in which samples were taken.

**TABLE 1-1  
FINAL TESTING PROTOCOL**

	Sunday Feb. 6	Monday Feb. 7	Tuesday Feb. 8	Wednesday Feb. 9	Thursday Feb. 10	Friday Feb. 11	Sunday Feb. 20
<b>SOURCE TESTING</b>							
<b>AM</b>	<b>Arrival</b>	#1 HM, HF (Multiclone)	#3 HM, HF (Multiclone)	#3 Hg	#2 Method 5/8 In & Out	#3 Method 5/8 In & Out	
	<b>Site Check</b>	#1 HCl, HF NH <sub>3</sub>	#3 HCl, HF NH <sub>3</sub>	#7 MSW Sample #7 Res Sample	#11 MSW Sample #11 Res Sample	#15 MSW Sample #15 Res Sample	
		#1 MSW Sample #1 Res Sample	#4 MSW Sample #4 Res Sample	#5 HCl, HF, NH <sub>3</sub>	#7 HCl, HF, NH <sub>3</sub>	#10 HCl, HF, NH <sub>3</sub>	
		#2 HM, HF (Multiclone)	#4 HM, HF (Multiclone)	#8 MSW Sample #8 Res Samples	#8 HCl, HF NH <sub>3</sub>	#11 HCl, HF NH <sub>3</sub>	
		#2 HCl, HF NH <sub>3</sub>	#4 HCl, HF NH <sub>3</sub>		#12 MSW Sample #12 Res Sample	#16 MSW Sample #16 Res Sample	
		#2 MSW Sample #2 Res Sample	#5 MSW Sample #5 Res Sample				
<b>PM</b>	<b>Equipment Preparation</b>	#1 Hg	#2 Hg	#1 Method 5/8 In & Out	#1 Andy In & Out	#2 Andy In & Out	
		#3 MSW Sample #3 Res Sample	#6 MSW Sample #6 Res Sample	#9 MSW Sample #9 Res Sample	#13 MSW Sample #13 Res Sample	#17 Sample #17 Res Sample	
				#6 HCl, HF, NH <sub>3</sub>	#9 HCl, HF, NH <sub>3</sub>	#12 HCl, HF, NH <sub>3</sub>	
				#10 MSW Sample #10 Res Sample	#14 MSW Sample #14 Res Sample	#18 MSW Sample #18 Res Sample	
<b>CONTINUOUS MONITORING</b>							
	<b>Set-Up and Testing with O'Connor</b>	Start 24 hr/day NO <sub>x</sub> , CO and O <sub>2</sub>					End 24 hr/day NO <sub>x</sub> , CO and O <sub>2</sub>
		Start 8 hr/day CO <sub>2</sub> , SO <sub>2</sub> and NMHC				End 8 hr/day CO <sub>2</sub> , SO <sub>2</sub> and NMHC	Return Equipment

**NOTE:**  
 HM - Heavy metal sampling  
 MSW - Municipal solid waste  
 Multiclone - SoRI five-stage cyclone sampler  
 Andy - Andersen ten-stage cascade impactor  
 In & Out - Simultaneous testing of the inlet and outlet of the Apitron  
 NMHC - Non-methane hydrocarbon  
 Res - Ash residue sample

**SECTION 2**  
**SUMMARY OF AIR EMISSIONS**  
**TEST RESULTS**

**SECTION 2**  
**SUMMARY OF AIR EMISSIONS TEST RESULTS**

**A. TEST ARRANGEMENTS**

Testing of air emissions from the rotary combustor/boiler system burning municipal solid waste was conducted in Gallatin, Tennessee. The Resource Authority in Sumner County (RASCO) operates two 100-ton per day. (TPD) rotary combustors attached to waterwall-type boilers in a solid waste processing facility designed to produce a total of 45,000 pounds per hour (TPH) of steam. The facility began operation in December, 1981. The air emissions testing was performed from February 6 to 21, 1983.

Permission to test the Gallatin facility was obtained through the efforts of the O'Connor Combustor Corporation and was approved by RASCO. Cooper Engineers was the prime organizer and principal investigator with subcontracts to Chemecology Corporation for some of the on-site sampling and measurements. Several subcontractors were retained for special off-site analyses made on samples returned to the San Francisco Bay Area.

**B. DEVELOPMENT OF TESTING METHODOLOGY**

The air emissions testing methodology emerged from a series of meetings with representatives of BAAQMD, CWMB, and CARB. Although U.S. EPA methods were utilized wherever possible, additional methods were applied to provide data that would be applicable to other air quality management and air pollution control districts in California. Emphasis was given to identifying "non-regulated" air pollutants as well as traditionally "regulated" air pollutants and process variables. The incoming municipal solid waste (MSW), residue, specially processed solid waste, and two separate incoming waste materials were also tested.

**C. REGULATED AIR POLLUTANTS**

The results of air emissions tests for the "regulated" or criteria air pollutants — those named in the New Source Review Rules and New Source Performance Standards — are shown in Table 2-1. The unabated emissions are given in average values of four units of measure:

**TABLE 2-1  
AVERAGE UNABATED AIR EMISSIONS DATA  
FROM THE GALLATIN ROTARY COMBUSTOR**

**"REGULATED AIR POLLUTANTS"**

Pollutant	Average Concentration	"Worst Case" Rolling Average Concentration (Time Period)	Average lb/hr	Average <sup>(1)</sup> lb/ton	Average <sup>(2)</sup> lb/10 <sup>6</sup> Btu
<b>Particulate:</b>					
U.S. EPA & BAAQMD (without condensibles)	2.92 gr/SDCF at 12% CO <sub>2</sub>	—	170.0	42.5	5.35
SCAQMD & Other CA (with condensibles)	2.92 gr/SDCF at 12% CO <sub>2</sub>	—	170.0	42.5	5.35
NO <sub>x</sub>	147 ppm <sub>dv</sub> at 7% O <sub>2</sub>	241 ppm <sub>dv</sub> at 7% O <sub>2</sub> (1 Hr)	9.11	2.2	
<b>SO<sub>2</sub>:</b>					
U.S. EPA Method 8	154 ppm <sub>dv</sub> at 7% O <sub>2</sub>	—	9.49	2.38	0.300
Continuous Emissions Monitoring	182 ppm <sub>dv</sub> at 7% O <sub>2</sub>	651 ppm <sub>dv</sub> at 7% O <sub>2</sub> (1 Hr) 454 ppm <sub>dv</sub> at 7% O <sub>2</sub> (3 Hr)	11.41	2.8	0.424
NMHC	40.5 ppm <sub>dv</sub> at 7% O <sub>2</sub>	282.1 ppm <sub>dv</sub> at 7% O <sub>2</sub> (1 Hr)	1.09	0.232	0.0369
CO	540 ppm <sub>dv</sub> at 7% O <sub>2</sub>	2055 ppm <sub>dv</sub> at 7% O <sub>2</sub> (1 Hr)	17.88	4.5	0.631
Hg			0.0067	0.00171	0.00216
Pb			1.024	0.274	0.0353
Be			<0.00018	<0.000048	<0.0000062

(1) MSW feed rate approximately 92 TPD.

(2) Based on as-received MSW less the heating value of the residue, see Section 5 for U.S. EPA F-factor based emission factors.

- (1) Flue gas concentration of the pollutant (grains per Standard Dry Cubic Foot (gr/SDCF) at 12% CO<sub>2</sub> or ppm<sub>dv</sub> at 7% O<sub>2</sub>),
- (2) Pounds of pollutant per hour for the 100-TPD combustion unit (lb/hr),
- (3) Pounds of pollutant per ton of as-received MSW burned (lb/ton),
- (4) Pounds of pollutant per million Btu (lb/10<sup>6</sup> Btu) of heat input from the as-received MSW.

Table 2-2 gives the controlled, or abated, air emissions found at the Gallatin facility, as well as the control efficiencies of the facility's air pollution control equipment.

Anticipated air emissions at other planned rotary combustor facilities may be calculated by matching the unabated air emission factors reported here with the proposed plant's MSW mass or heat input and reducing the unabated emissions by the efficiencies of the planned air pollution control equipment (i.e., as required by BACT) where applicable. The maximum values, reported in ppm<sub>dv</sub> are the "rolling" averages of the "worst case" time periods and should be used only in Ambient Air Quality Impact Analyses (AAQIAs) for comparison with their corresponding short-term ambient air quality standards (e.g., the respective 1-hr, 2-hr, or 3-hr standards).

#### D. NON-REGULATED AIR POLLUTANTS

The results of air emissions tests for "non-regulated" air pollutants — those pollutants without a specific standard or regulation — are shown in Table 2-3. The data give average unabated air emissions values in a similar format to that in Table 2-1. A table showing abated air emissions for "non-regulated" air pollutants was not prepared although the reaction of sulfate and ammonia in the flue gas significantly reduced the amount of each that was emitted. Section 5, Subsection L, describes the reaction of sulfate and ammonia at the gas air heater (GAH) outlet to form ammonium bisulfate.

#### E. HEAVY METAL EMISSIONS

The results of air emissions tests for heavy metals are shown in Table 5-24. U.S. EPA Method 101 tests for total mercury were performed and the results are presented in Table 5-22. Table 5-25 shows the percentage of the specific heavy metals in three particle size ranges.

**TABLE 2-2  
AVERAGE ABATED AIR EMISSIONS DATA  
FROM THE GALLATIN ROTARY COMBUSTOR**

**"REGULATED AIR POLLUTANTS"**

Pollutant	Average Concentration	Average lb/hr	Average lb/ton <sup>(1)</sup>	Average lb/10 <sup>6</sup> Btu <sup>(2)</sup>
<b>Particulate:</b>				
U.S. EPA & BAAQMD (without condensibles)	0.0321 gr/SDCF at 12% CO <sub>2</sub>	2.74	0.715	0.0949
SCAQMD & Other CA (with condensibles)	0.0365 gr/SDCF at 12% CO <sub>2</sub>	3.10	0.766	0.0974
<b>SO<sub>2</sub>:</b>				
U.S. EPA Method 8	141 ppm <sub>dv</sub> at 7% O <sub>2</sub>	13.98	3.50	0.440

Air Pollution Control Equipment	Pollutant	Average Control Efficiency
Cyclone Only	Particulate	80.82% U.S. EPA-BAAQMD 78.47% SCAQMD-Other CA
Apitron only	Particulate	91.60% U.S. EPA-BAAQMD 91.53% SCAQMD-Other CA
Overall Cyclone/Apitron System	Particulate	98.39% U.S. EPA-BAAQMD 98.18% SCAQMD-Other CA

- (1) Process feed weight approximately 92 tons per day.  
 (2) Based on as-received MSW less the heating value of the residue.

**TABLE 2-3  
AVERAGE UNABATED AIR EMISSIONS DATA  
FROM THE GALLATIN ROTARY COMBUSTOR**

**"NON-REGULATED AIR POLLUTANTS"**

Pollutant	Average Concentration		Average lb/hr	Average lb/ton <sup>(2)</sup>	Average lb/10 <sup>6</sup> Btu <sup>(3)</sup>
	(ppm <sub>dv</sub> at 7% O <sub>2</sub> )	ppm <sup>(1)</sup>			
Total Sulfate	—	—	8.26	2.07	0.259
SO <sub>3</sub> (gaseous) <sup>(4)</sup>	40.3	—	3.85	0.97	0.121
SO <sub>4</sub> <sup>2-</sup> (particulate) <sup>(4)</sup>	—	48,000	4.41	1.10	0.138
HCl (gaseous)	509	—	19.8	5.27	0.761
Total Fluoride	—	—	0.232	0.0628	0.0099
HF (gaseous) <sup>(5)</sup>	5.11	—	0.116	0.0314	0.0050
F <sup>-</sup> (particulate) <sup>(5)</sup>	—	1,110	0.116	0.0314	0.0050
NH <sub>3</sub> (gaseous)	29.2	—	0.458	0.121	0.0162

- (1) Milligrams of HF or H<sub>2</sub>SO<sub>4</sub> per kilogram of total particulate emission.
- (2) Process feed weight approximately 92 tons per day.
- (3) Based on as received MSW less heating value of the residue.
- (4) Assumed that the SO<sub>4</sub><sup>2-</sup> on the filter and before (front half) was particulate SO<sub>4</sub><sup>2-</sup> and the back half was gaseous. Both calculated as H<sub>2</sub>SO<sub>4</sub>.
- (5) Data based on multiclone data; gaseous HF assumed to be in the back half and F<sup>-</sup> particulate in the front half.



The forecast of abated heavy metal emissions for other projects is dependent on the efficiencies of the planned air pollution control equipment in each particle size range and the amount of heavy metals in that size range. Details on particle sizing and heavy metal distributions are contained in Section 5, Subsection F of this report.

**F. SOLID WASTE AND COMBUSTION RESIDUE CHARACTERISTICS**

The municipal solid waste combusted during the week of February 7, 1983, in Gallatin, Tennessee, had on the average the following higher heating value (HHV) and moisture:

7,210 Btu/lb Dry Basis - HHV  
41.54% - Moisture  
4,215 Btu/lb As-received-HHV

The residue from the combustor average the following heating value and moisture:

2,140 Btu/lb Dry Basis - HHV  
59.16% - Moisture  
838 Btu/lb As-produced-HHV

The net average heat input to the combustor was  $29.01 \times 10^6$  Btu/hr.

**SECTION 3**

**DESCRIPTION OF THE GALLATIN  
ROTARY COMBUSTOR FACILITY**

**SECTION 3**  
**DESCRIPTION OF THE GALLATIN**  
**ROTARY COMBUSTOR FACILITY**

**A. GENERAL DESCRIPTION**

The Gallatin facility utilizes two 100 TPD O'Connor rotary combustors to burn all of the MSW that is generated by Sumner County's 80,000 residents. Operating 24 hours a day, seven days a week, the facility supplies steam to three customers and also co-generates 500 kilowatts of electricity. The facility has its combustion equipment and storage pit enclosed in a building that is visually appealing and compatible with the semi-rural industrial park in which it is located. (Figure 3-1, Photographs 1 and 2.)

The various aspects of the facility can best be shown by the photographs and by the discussion below. The photographs (Figure 3-1) are contained at the end of Section 3.

See Figure 3-2 for a cross-section of the facility.

**B. WASTE RECEIVING AND STORAGE AREA**

Trucks are weighed entering and exiting the plant. After weighing, the collection vehicles proceed to the 550-ton storage pit to dump their contents. (Figure 3-1, Photograph 3.)

Two overhead cranes mix the solid waste in the pit and deposit it into the feed hoppers for each rotary combustor. (Figure 3-1, Photograph 4.)

**C. WASTE COMBUSTION SYSTEM**

Once the solid waste is in the feed hopper, it is fed into the rotary combustor by a ram feed system (Figure 3-1, Photographs 5 and 6) at a rate that is determined by the operator in the control room. Combustion air is pre-heated to 450°F and then forced into the combustor as underfire and overfire air. Figure 3-1, Photograph 7 shows the facility control room and control panel.

FIGURE 3-2

CROSS-SECTION OF GALLATIN, TENNESSEE, FACILITY

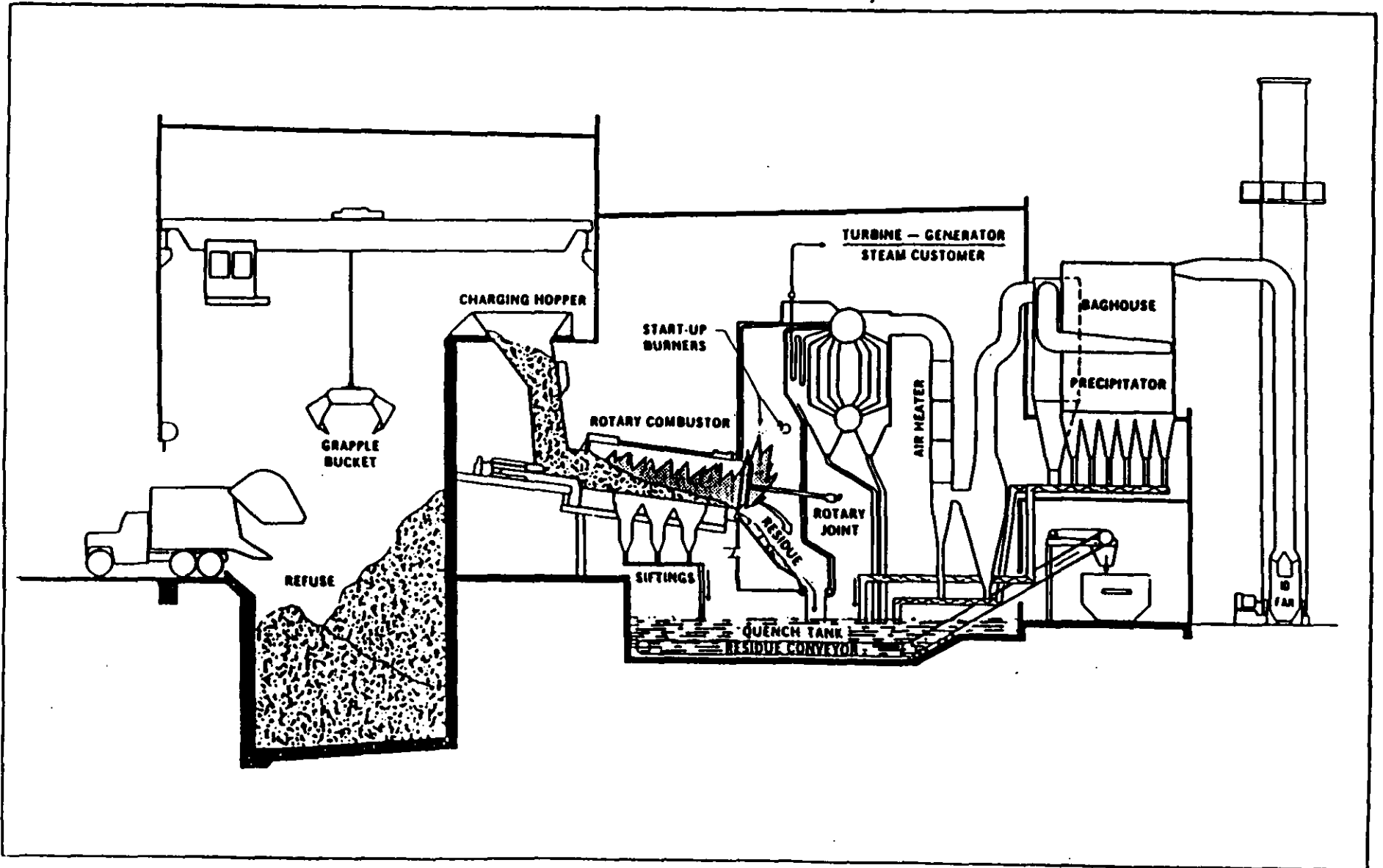

As combustion takes place, the solid wastes are mixed by the rotation of the rotary combustor barrel (approximately 1/5 RPM) and moved the length of the rotary combustor. Figure 3-1, Photograph 8 shows the outside of the rotary combustor and Figure 3-1, Photograph 9 shows the inside of the rotary combustor barrel.

The rotary combustor is mated to a Keeler waterwall boiler. Figure 3-1, Photograph 10 shows the top of the boiler and the steam drum. The bottom ash passes through the base of the boiler and into the quench tank to be removed by an ash drag system and is deposited into a dumpster. Figure 3-1, Photograph 11 shows the bin with combustion residue ready for transportation to the landfill.

Steam is produced in each unit at a pressure and temperature of 425 psig and 525°F at a maximum rate of 27,000 lb/hr. All the steam produced is passed through a turbine generator before being distributed to the steam customers at approximately 200 psig.

#### D. AIR POLLUTION CONTROL SYSTEM

After the heat is extracted in the boiler, the flue gases pass through the GAH, where additional heat is captured to warm the combustion air. The flue gases then pass through a cyclone dust collector and to an electrostatically assisted baghouse, manufactured by Apitron, as shown in Figure 3-1, Photographs 12 and 13.

#### E. MATERIALS RECOVERY SYSTEM

In conjunction with the plant MSW feed system, there is an independent materials recovery system owned and operated by National Recovery Technologies, Inc. (NRT) of Nashville, Tennessee. This facility operates in parallel with the RASCO. The NRT process employs a combination of magnetic, mechanical, and manual separation steps to remove non-combustibles from the waste stream and provide an "enhanced" material to burn. The rotary combustor can burn both the MSW "as delivered" and the NRT processed material. During the testing period, the operation was monitored burning both types of waste.

## **F. OPERATION OF THE ROTARY COMBUSTOR**

In a waterwall incinerator burning MSW it is difficult to control the steam flow output and excess air levels in the boiler due to the wide range of variability in the physical and chemical properties of the fuel being used.

Combustion of MSW in the rotary combustor/boiler can be controlled by adjusting the combustion air flow, MSW feed rate, and the combustor RPM. The control room operator, by observing the rotary combustor video monitor and control system readings, can compensate for the variability of the fuel.

For smooth and continuous operation of the unit, it is essential that the MSW has been thoroughly mixed in the pit prior to feeding and then properly loaded into the charging chute. Maintaining an even feed from the rams is also essential for even burning and hence a constant steam flow. The time for the rams to make one complete charging cycle is around six minutes and if there is a hopper jam, it can usually be broken by manually operating both rams together.

The firing conditions for the best operation of the unit are as follows:

Steam flow should run in the 22-25,000 lb/hr range. Maximum for unit is 27,000 lb/hr.

Maintain combustor inlet temperature at about 800°F (see thermocouple at entrance to the rotary combustor - Figure 3-1, Photograph 9).

Maintain "furnace" temperature at about 1200°F (thermocouple in the furnace is at the entrance to the screen tubes and superheater).

These two temperatures indicate the fuel burning conditions and give advance warning of changes taking place in the combustor. If the temperature at the combustor inlet rises rapidly or is running above furnace temperature, then the combustor is burning too short. This indicates that the feed rate should be increased. If this persists, even with the higher feed rate, the material being burned is probably very dry and it may be necessary to decrease the air in the windbox in zone "A", i.e., closest to the feed end of the combustor.

The furnace temperature is an index of the heat input to the boiler. At a typical operating load of 22,000 to 25,000 lb/hr steam flow, this temperature should be around 1200°F., plus or minus 100°F. If this temperature increases, there is too much fuel going into the combustor. If it decreases, there is not enough fuel being fed. If it drops rapidly, there is probably a jam in the inlet chute preventing fuel from entering the combustor.

When the combustor inlet and boiler furnace temperatures are uniformly different and are not changing, then the MSW feed rate, combustor RPM and combustor airflow are adequate.

The combustor rotates at a constant speed, under normal operating conditions; this is about one revolution every five minutes. For very wet refuse, the combustor may have to be slowed below this speed and for very dry refuse, the speed may be increased.

Airflow is maintained at a constant level and is distributed to the combustor through a windbox. The combustor windbox is divided into three zones (A, B, C) along the length of the combustor, as shown in Figure 3-3. These zones are used to distribute the combustion air to the fuel bed in the combustor and they can be adjusted by the control room operator to maintain the correct combustion temperatures as described above.

Each zone is divided into 3 sections across the combustor and these are controlled by a manual damper. All of the dampers are set wide open except for the three (3) dampers on the left hand side of the unit. These three dampers control the overfire air (OFA) inside the combustor barrel and are very important for controlling burnout conditions. In general:

- o For dry garbage and/or "sticky" ash - open the OFA dampers.
- o For wet garbage and/or bad burnout - close the OFA dampers.

The combustor is designed to operate at 50% excess air. This translates to an approximate value of 6% (wet) O<sub>2</sub> on the control room recorder.

FIGURE 3-3

AIR / GAS FLOW SCHEMATIC

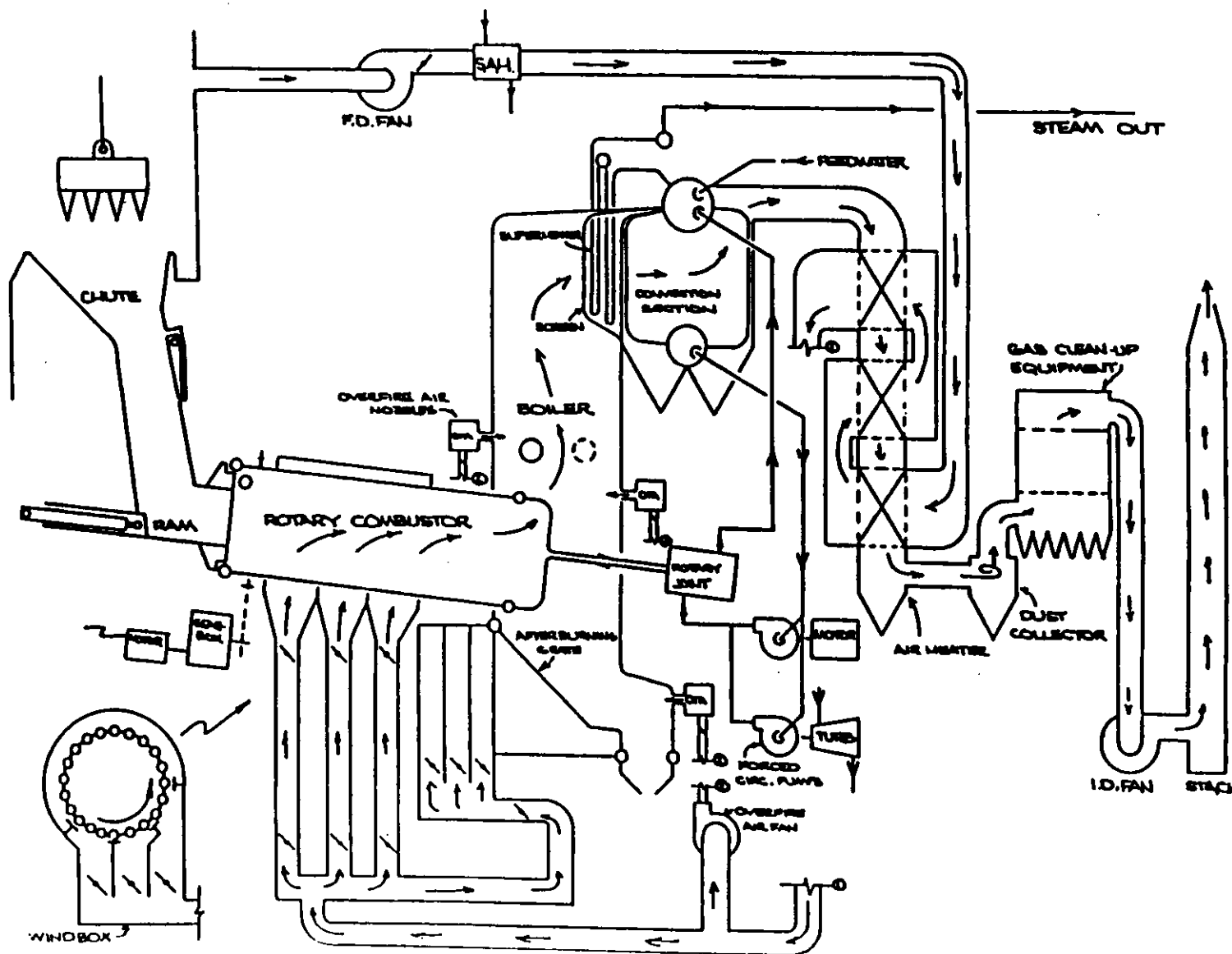



For proper combustion the  $O_2$  should be in this region.

If  $O_2$  is consistently below 6%, the steam flow will probably be above 25,000 lb/hr. This indicates over feeding or a hot fuel and the ram feed rate should be reduced.

If the  $O_2$  is consistently above 6%, the steam flow will probably be below 20,000 lb/hr. The operator should check for any obvious air infiltration such as boiler ports left open or low water level in the quench tank, i.e., poor boiler seal. If there is no air infiltration, then increase the ram feed rate.

The combustor controls can be operated either manually or in an automatic mode. The following sections describe the development of the automatic combustion control system.

#### 1. ORIGINAL DESIGN OF AUTOMATIC COMBUSTION CONTROL SYSTEM

An ACC system was designed for the rotary combustors at the Gallatin facility to produce the required steam flow, steam drum pressure, and excess air levels by controlling the combustion air flow, MSW feed rate and combustor RPM.

Figure 3-4 shows the relationship between the operating parameters of steam flow and excess air to the operating variables of combustion air flow, MSW feed rate and combustor RPM as it was originally designed.

#### 2. CHANGES TO ACC SYSTEM

Once the facility had been in operation, it was necessary to incorporate some changes to the ACC system in order to achieve a more consistent operation of the units. The initial changes that were made were to include limits in the controllers so that the combustion air flow, MSW feed rate and combustor RPM would vary within a specified operating range. This made the operation more consistent and helped to avoid overfeeding situations.

Other changes that were made included changing the basic control loop and the steam control system in an effort to produce a more consistent steam flow to the facility's customers as well as improving burnout.

FIGURE 3-4

ORIGINAL GALLATIN AUTOMATIC COMBUSTION CONTROL SYSTEM

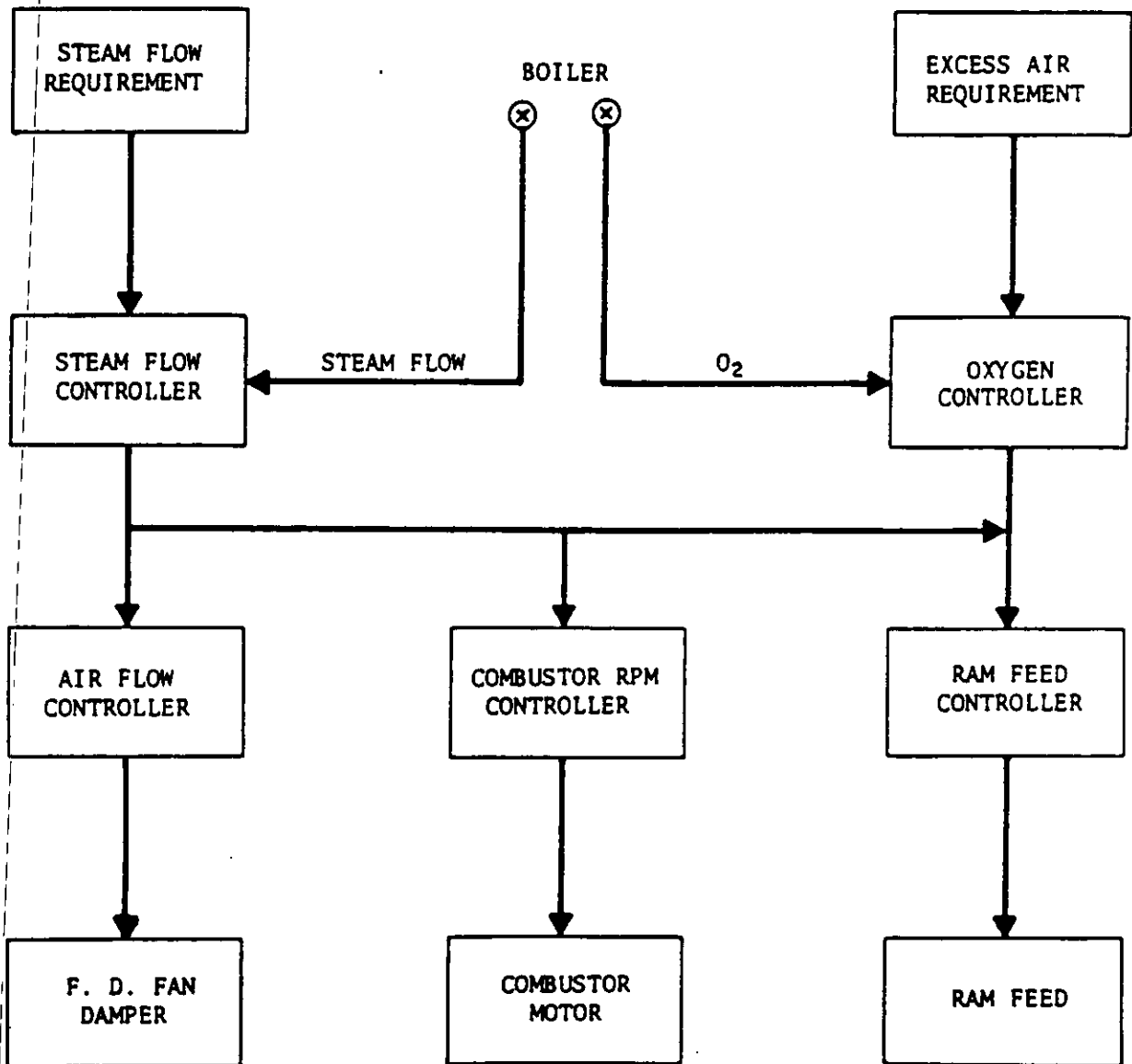

An automatic controller was included on the combustor inlet A-zone air damper in order to control the air flow and maintain a constant temperature at the combustor inlet.

It was found from earlier Cooper Engineers testing that the boiler overfire air and grate air was ineffective, so these systems were no longer used and all of the combustion air is now introduced through the rotary combustor as underfire and overfire air.

### 3. ACC SYSTEM DURING TESTING

At the time that the testing took place in February 1983, the ACC system had been revised and simplified and the basic control loop is shown in Figure 3-5.

In conjunction with the revised instrumentation control loop the by-pass valve on the steam flow control (schematic shown in Figure 3-6) was opened fully so that the boiler drum pressure was now controlled by the nozzle flow rate of the turbine. This allows the boiler drum pressure to vary while providing a more consistent steam flow to the customers.

The combustor is generally operated under the revised ACC system except in those situations where the unit is being run at a reduced load or an unusual fuel is being encountered, requiring operator assistance.

FIGURE 3-5

MODIFIED GALLATIN AUTOMATIC COMBUSTION CONTROL SYSTEM

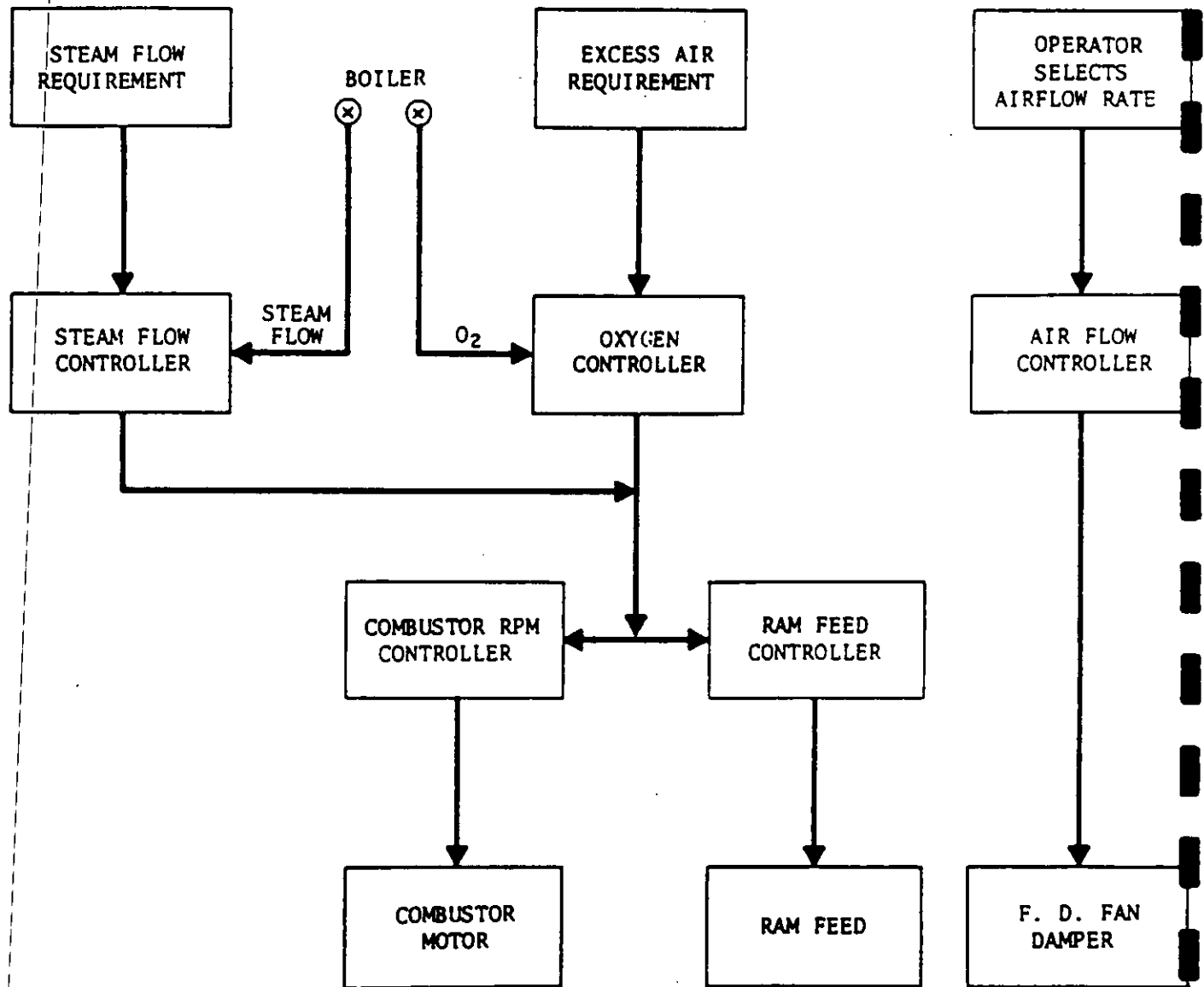

FIGURE 3-6  
STEAM SYSTEM CONTROL

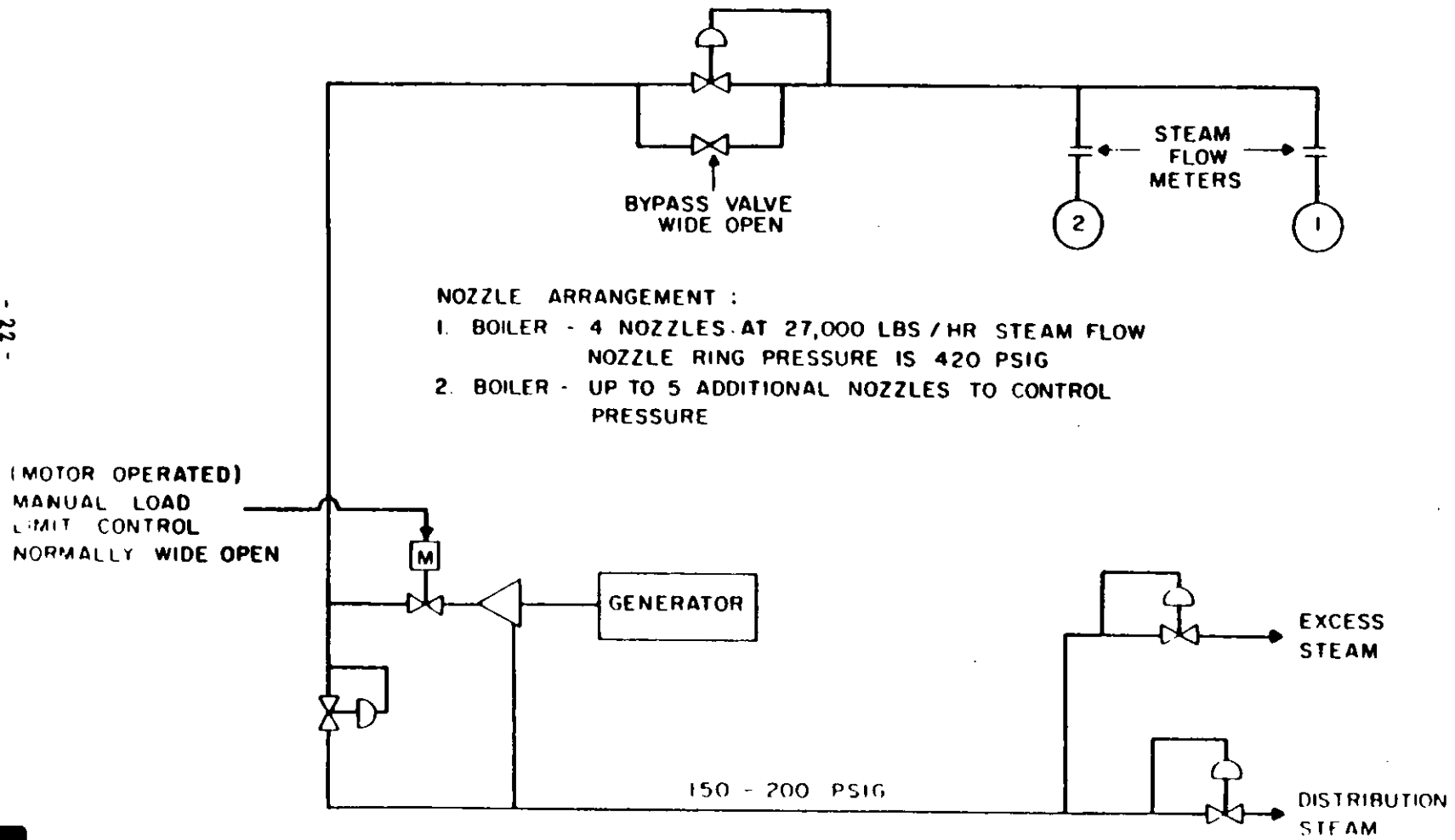
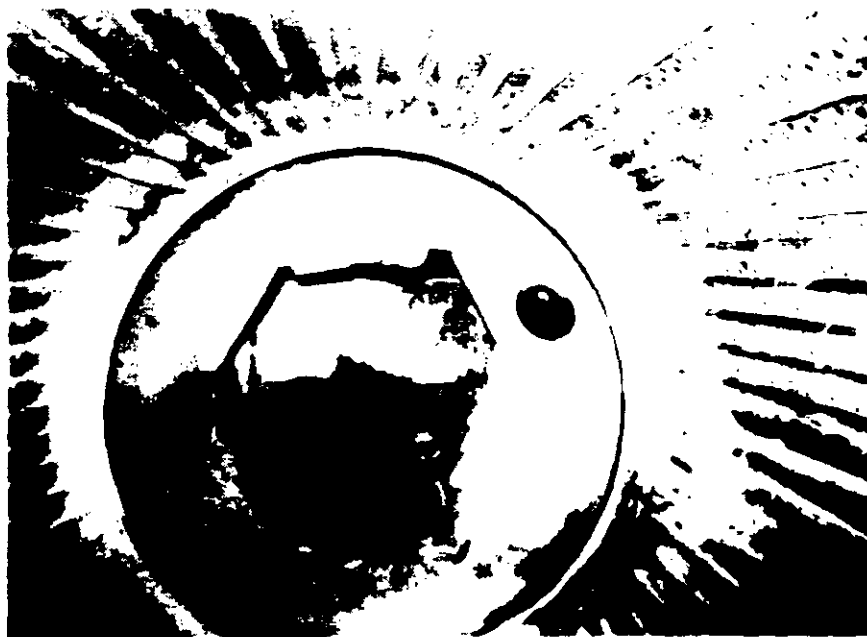

Figure 3-1 (Continued)



Photograph 8  
Outside of Combustor



Photograph 9  
Inside of Combustor

**SECTION 4**

**AIR EMISSIONS TESTING METHODOLOGY**

## SECTION 4 AIR EMISSIONS TESTING METHODOLOGY

### A. PURPOSE

The air emissions testing of the Gallatin rotary combustor was conducted to obtain the most representative air emissions data possible for the WCA waste-to-energy project. The Gallatin facility was chosen to present a comparison of the air emissions factors from American municipal solid waste versus the emission factors from the Kure, Japan waste because the two facilities' combustion systems are basically identical. The two Gallatin O'Connor units are 100 TPD each and the Kure O'Connor units are 165 TPD each. Because of the similar combustion configuration much of the air emissions testing and analyses performed were similar.

### B. FINAL TESTING SCHEDULE

The testing schedule for the two weeks at Gallatin is described in Table 4-1. The testing schedule sequence differs somewhat from the schedule developed prior to arrival in Gallatin because the multiclone sampling had to be scheduled later in the week in order that a sampling port of sufficient size be installed for the multiclone sampling.

The actual daily CEM testing schedule included approximately 23 hours of measurements with less than 1 hour for spanning, calibrating, and draining water from the sample conditioner. The calibration was typically done in the morning and evening as follows:  $\text{NO}_x$  was calibrated for 15 minutes at 0 and 98  $\text{ppm}_{\text{dV}}$ . The  $\text{SO}_2$  instrument was calibrated for 15 minutes at 525  $\text{ppm}_{\text{dV}}$ , or 93  $\text{ppm}_{\text{dV}}$  depending on  $\text{SO}_2$  range, and 0  $\text{ppm}_{\text{dV}}$ . Oxygen was calibrated with the ambient air (21%  $\text{O}_2$ ) and a zero oxygen gas.  $\text{CO}_2$  was calibrated with 12.26% and 0% span gases. The non-methane hydrocarbon analyzer was calibrated with a zero gas and a  $\text{CO}/\text{CO}_2/\text{CH}_4/\text{C}_3\text{H}_8$  mix (47.9  $\text{ppm}_{\text{dV}}$  / 2.09% / 50.5  $\text{ppm}_{\text{dV}}$  / 50.6  $\text{ppm}_{\text{dV}}$ ). This mix would give a NMHC standard of 151.8  $\text{ppm}_{\text{dV}}$ , which is  $50.6 \times 3$ . CO was calibrated with a span gas cylinder at 2,089  $\text{ppm}_{\text{dV}}$  and 0  $\text{ppm}_{\text{dV}}$ .



**TABLE 4-1**  
**AIR EMISSIONS TESTING AND SAMPLING SCHEDULE**  
**GALLATIN ROTARY COMBUSTOR<sup>(1)</sup>**  
**February 6-21, 1983**

Sunday, February 6th

Test organization and equipment set-up  
 U.S. EPA Method 1, 2, 3 and 4 at combustor outlet  
 and cyclone outlet

Monday, February 7th

0800 to 2400	1.	Continuous emissions monitoring at combustor outlet: NO <sub>x</sub> , O <sub>2</sub> , SO <sub>2</sub> , CO, CO <sub>2</sub> .
0800 to 2400	2.	Continuous recording of combustor/boiler process data.
1042	3.	Solid waste sample taken for proximate, ultimate and calorific value analyses.
1050 to 1437	4.	U.S. EPA Method 101, Hg at combustor outlet
1120	5.	Residue sample taken for proximate, ultimate and calorific value analyses.
1135 to 1722	6.	Continuous emissions monitoring at combustor outlet for NMHC.

Tuesday, February 8th

0800 to 2400	1.	Continuous emissions monitoring at combustor outlet: NO <sub>x</sub> , O <sub>2</sub> , SO <sub>2</sub> , CO, CO <sub>2</sub> .
0800 to 2400	2.	Continuous recording of combustor/boiler process data.
0855 to 1130	3.	U.S. EPA Method 101, Hg at combustor outlet.
0910 to 0930	4.	Four solid waste samples taken for proximate, ultimate and calorific value analyses.
1000 to 1840	5.	Continuous emissions monitoring at combustor outlet for NMHC.
1015	6.	Residue sample taken for proximate, ultimate and calorific value analyses.
1030 to 1056	7.	Acid gases (NH <sub>3</sub> , HCl, HF) at combustor outlet.
1122 to 1143	8.	Acid gases (NH <sub>3</sub> , HCl, HF) at combustor outlet.
1130	9.	Solid waste sample taken for proximate, ultimate and calorific value analyses.
1321 to 1500	10.	U.S. EPA Method 5/8, particulate, sulfate, SO <sub>2</sub> at combustor outlet.
1322 TO 1507	11.	U.S. EPA Method 5/8, particulate, sulfate, SO <sub>2</sub> at Apitron outlet.
1540	12.	Solid waste sample taken for proximate, ultimate and calorific value analyses.
1640	13.	Residue sample taken for proximate, ultimate and calorific value analyses.
1647 to 1825	14.	U.S. EPA Method 5/8, particulate, sulfate, SO <sub>2</sub> at combustor outlet.
1648 to 1830	15.	U.S. EPA Method 5/8, particulate, sulfate, SO <sub>2</sub> at Apitron outlet.
1700	16.	Solid waste sample taken for proximate, ultimate and calorific value analyses.
1720	17.	Residue sample taken for proximate, ultimate and calorific value analyses.

(1) All sampling designated as "combustor outlet" actually sampled at the GAH outlet.

**TABLE 4-1 (Continued)**  
**AIR EMISSIONS TESTING AND SAMPLING SCHEDULE**  
**GALLATIN ROTARY COMBUSTOR<sup>(1)</sup>**  
**February 6-21, 1983**

Wednesday, February 9th

0000	to	2400	1.	Continuous emissions monitoring at combustor outlet: NO <sub>x</sub> , O <sub>2</sub> , SO <sub>2</sub> , CO, CO <sub>2</sub> .
0000	to	2400	2.	Continuous recording of combustor/boiler process data.
0820			3.	U.S. EPA Method 2, Velocity at Apitron outlet.
0940	to	1215	4.	U.S. EPA Method 101, Hg at combustor outlet.
0950			5.	Solid waste sample taken for proximate and ultimate analysis.
1019	to	1622	6.	Aerodynamic particle size distribution by Andersen Mark II at Apitron outlet.
1020			7.	Residue sample taken for proximate, ultimate and calorific value analyses.
1107	to	1131	8.	Acid gases (NH <sub>3</sub> , HCl, HF) at combustor outlet.
1210	to	1237	9.	Acid gases (NH <sub>3</sub> , HCl, HF) at combustor outlet.
1210	to	1612	10.	Continuous emissions monitoring at combustor outlet for NMHC.
1321	to	1347	11.	Acid gases (NH <sub>3</sub> , HCl, HF) at combustor outlet.
1400			12.	Solid waste sample taken for proximate, ultimate and calorific value analyses.
1400	to	1405	13.	Aerodynamic particle size distribution by Andersen Mark II at combustor outlet.
1420			14.	Residue sample taken for proximate, ultimate and calorific value analyses.
1452	to	1513	15.	Acid gases (NH <sub>3</sub> , HCl, HF) at combustor outlet.
1544	to	1559	16.	Aerodynamic particle size distribution by Andersen Mark II at combustor outlet.

Thursday, February 10th

0000	to	2400	1.	Continuous emissions monitoring at combustor outlet: NO <sub>x</sub> , O <sub>2</sub> , SO <sub>2</sub> , CO, CO <sub>2</sub> .
0000	to	2400	2.	Continuous recording of combustor/boiler process data.
0855	to	2127	3.	Aerodynamic particle size distribution by Andersen Mark II at Apitron outlet.
0855	to	0904	4.	Aerodynamic particle size distribution by Andersen Mark II at combustor outlet.
0900	to	2240	5.	Continuous emissions monitoring at combustor outlet for NMHC.
0910			6.	Solid waste sample taken for proximate, ultimate and calorific value analyses.
0920			7.	Residue sample taken for proximate, ultimate and calorific value analyses.
1000	to	1020	8.	Acid gases (NH <sub>3</sub> , HCl, HF) at combustor outlet.
1019	to	1120	9.	Aerodynamic particle size distribution and heavy metals by Flow Sensor five-stage multiclone and acid gases (NH <sub>3</sub> , HCl, HF) at combustor outlet.
1102	to	1129	10.	Acid gases (NH <sub>3</sub> , HCl, HF) at combustor outlet.
1217	to	1226	11.	Aerodynamic particle size distribution by Andersen Mark II at combustor outlet.
1345	to	1515	12.	Aerodynamic particle size distribution and heavy metals by Flow Sensor five-stage multiclone and acid gases (NH <sub>3</sub> , HCl, HF) at combustor outlet.
1410			13.	Solid waste sample taken for proximate, ultimate and calorific value analyses.
1420			14.	Residue sample taken for proximate, ultimate and calorific value analyses.

(1) All sampling designated as "combustor outlet" actually sampled at the GAI outlet.

**TABLE 4-1 (Continued)**  
**AIR EMISSIONS TESTING AND SAMPLING SCHEDULE**  
**GALLATIN ROTARY COMBUSTOR (1)**  
**February 6-21, 1983**

Friday, February 11th

0000 to 2400	1.	Continuous emissions monitoring at combustor outlet: NO <sub>x</sub> , O <sub>2</sub> , SO <sub>2</sub> , CO, CO <sub>2</sub> .
0000 to 2400	2.	Continuous recording of combustor/boiler process data.
1000 to 1724	3.	Continuous emissions monitoring at combustor outlet for NMHC.
1007 to 1122	4.	Aerodynamic particle size distribution and heavy metals by Flow Sensor five-stage multiclone and acid gases (NH <sub>3</sub> , HCl, HF) at combustor outlet.
1300 to 1415	5.	Aerodynamic particle size distribution and heavy metals by Flow Sensor five-stage multiclone and acid gases (NH <sub>3</sub> , HCl, HF) at combustor outlet.
1552 to 1735	6.	U.S. EPA Method 5, particulate at combustor outlet.
1554 to 1744	7.	U.S. EPA Method 5, particulate at Apitron outlet.
1553 to 1732	8.	U.S. EPA Method 5, particulate at cyclone outlet.
1600	9.	NRT sample taken for proximate, ultimate and calorific value analyses.
1630	10.	Residue sample taken for proximate, ultimate and calorific value analyses.

Saturday, February 12th

0000 to 2400	1.	Continuous emissions monitoring at combustor outlet: NO <sub>x</sub> , O <sub>2</sub> , SO <sub>2</sub> , CO, CO <sub>2</sub> .
0000 to 2400	2.	Continuous recording of combustor/boiler process data.

Sunday, February 13th

0000 to 1500	1.	Continuous emissions monitoring at combustor outlet: NO <sub>x</sub> , O <sub>2</sub> , SO <sub>2</sub> , CO, CO <sub>2</sub> .
0000 to 1500	2.	Continuous recording of combustor/boiler process data.

Monday, February 14th

0800 to 2400	1.	Continuous emissions monitoring at combustor outlet: NO <sub>x</sub> , O <sub>2</sub> , SO <sub>2</sub> , CO, CO <sub>2</sub> .
0800 to 2400	2.	Continuous recording of combustor/boiler process data.

Tuesday, February 15th

0000 to 1100	1.	Continuous emissions monitoring at combustor outlet: NO <sub>x</sub> , O <sub>2</sub> , SO <sub>2</sub> , CO, CO <sub>2</sub> .
0000 to 1100	2.	Continuous recording of combustor/boiler process data.

(1) All sampling designated as "combustor outlet" actually sampled at the GAI outlet.

TABLE 4-1 (Continued)  
AIR EMISSIONS TESTING AND SAMPLING SCHEDULE  
GALLATIN ROTARY COMBUSTOR<sup>(1)</sup>  
February 6-21, 1983

Wednesday, February 16th

- |              |    |   |
|--------------|----|---|
| 0000 to 1100 | 1. | Continuous emissions monitoring at combustor outlet: NO <sub>x</sub> , O <sub>2</sub> , SO <sub>2</sub> , CO, CO <sub>2</sub> . |
| 0000 to 1100 | 2. | Continuous recording of combustor/boiler process data.  |

Thursday, February 17th

UNIT WAS DOWN ALL DAY

Friday, February 18th

- |              |    |   |
|--------------|----|---|
| 0000 to 1600 | 1. | Continuous emissions monitoring at combustor outlet: NO <sub>x</sub> , O <sub>2</sub> , SO <sub>2</sub> , CO, CO <sub>2</sub> . |
| 0000 to 1600 | 2. | Continuous recording of combustor/boiler process data.  |

Saturday, February 19th

UNIT WAS DOWN ALL DAY

Sunday, February 20th

- |              |    |   |
|--------------|----|---|
| 0000 to 2400 | 1. | Continuous emissions monitoring at combustor outlet: NO <sub>x</sub> , O <sub>2</sub> , SO <sub>2</sub> , CO, CO <sub>2</sub> . |
| 0000 to 2400 | 2. | Continuous recording of combustor/boiler process data.  |

Monday, February 21st

- |              |    |   |
|--------------|----|---|
| 0000 to 0800 | 1. | Continuous emissions monitoring at combustor outlet: NO <sub>x</sub> , O <sub>2</sub> , SO <sub>2</sub> , CO, CO <sub>2</sub> . |
| 0000 to 0800 | 2. | Continuous recording of combustor/boiler process data.  |
| 0800         |    | END OF TEST   |

(1) All sampling designated as "combustor outlet" actually sampled at the GAH outlet.

### C. SAMPLING LOCATIONS

The sampling locations used for the testing are shown in Figure 4-1, a cross-section of the plant. In this figure the different sampling points are noted. Sampling point 3 described as the "Combustor Outlet" on all of the air emissions test data tables, is actually at the GAH outlet.

Figures 4-2, 4-3, and 4-4 show the dimensions of the ducting and location of the sampling ports for the different sampling points. Pictures of two of the sampling sites, point 3 and point 1, are shown in Figures 4-5 and 4-6, respectively.

### D. SAMPLING METHODS

The sampling methods used to extract and analyze the gas samples from sampling points 1, 2, and 3 (on Figure 4-1) are detailed with their own references in the Appendix, Part 1. Described are sampling and analysis for initial molecular weight and percent water, velocity traverse and volumetric flow rate, particulate emissions, sulfur oxides, mercury, acid gas, and aerodynamic particle size by the Andersen Mark II Cascade Impactor and the Flowsensor Multiclone. The sampling methods in general followed U.S. EPA test methods as given in the Code of Federal Regulations, Title 40, Part 60, Appendix A and Part 61, Appendix B.

<u>Parameter</u>	<u>Test Method</u>
Gas analysis for molecular weight	U.S. EPA Method 3
Moisture in stack gases	U.S. EPA Method 4
Velocity traverse points	U.S. EPA Method 1
Velocity and volumetric flow rate	U.S. EPA Method 2
Particulate, SO <sub>2</sub> , SO <sub>3</sub> emissions	U.S. EPA Method 5/8
Mercury emissions	U.S. EPA Method 101

The combination train, U.S. EPA Method 5/8, is a Method 5 train on the front half and a Method 8 on the back half of the train. This allows the determination of particulate, particulates with condensibles, SO<sub>2</sub>, and SO<sub>3</sub> emissions with one train. Particle sizing was performed with a typical Andersen train: an Andersen cascade impactor connected via tubing to a condensing section and then to a pump/meter set-up. The five-stage Flowsensor Multiclone was set up similarly but the cyclone allows for more sample to be collected, so heavy metals could be determined on the fractions collected.

FIGURE 4-1  
 CROSS-SECTION OF FACILITY SHOWING SAMPLING LOCATIONS

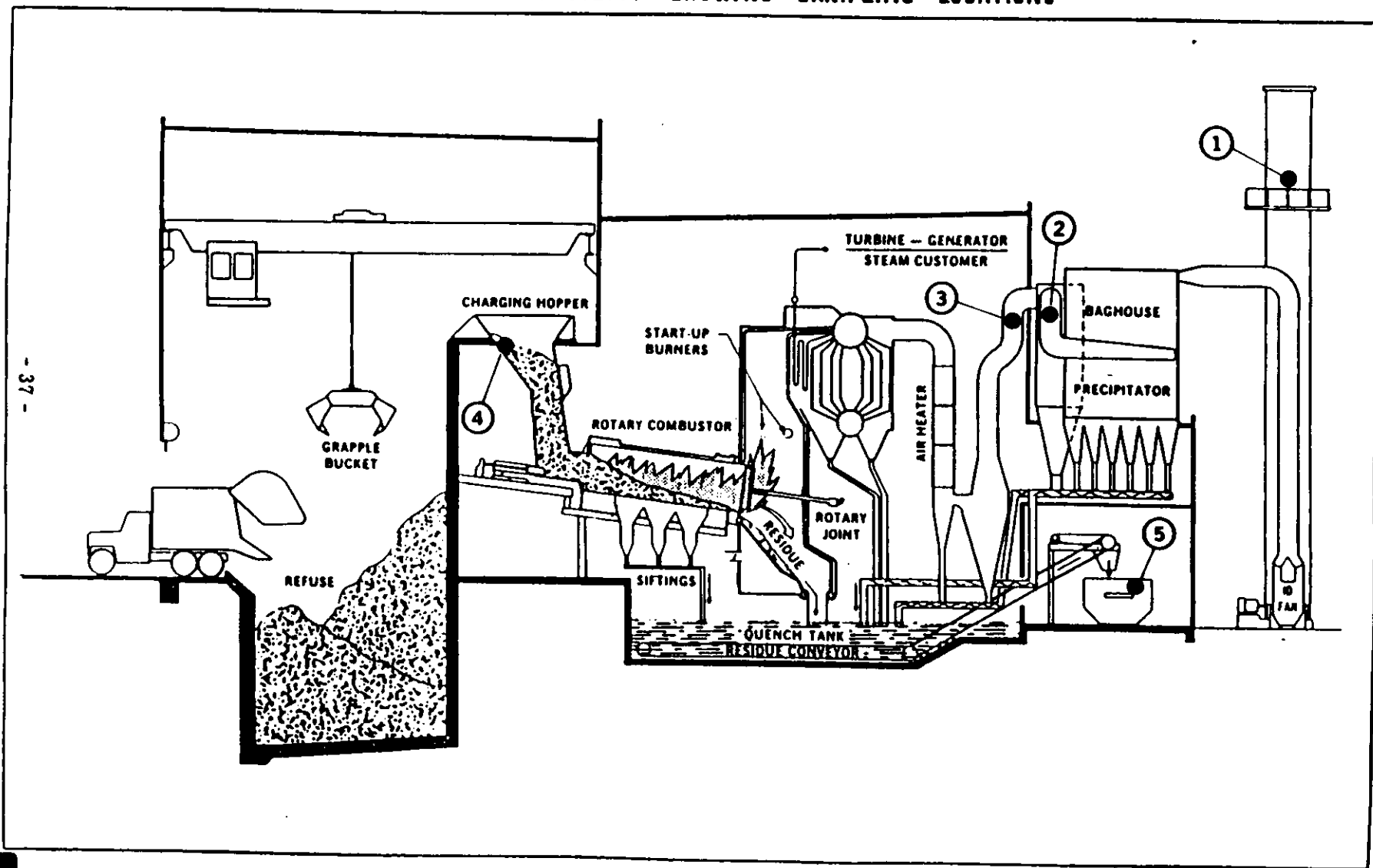

FIGURE 4-2

DIAGRAM OF SAMPLING POINT 3, GAH OUTLET

NOTE: SAMPLING PORTS

TRAVERSING : 4" PIPE WITH 1/2 COUPLING (FEMALE) FOR CAP OR FLANGE

CEM : 2" PIPE WITH 1/2 COUPLING (FEMALE) FOR CAP OR FLANGE

TOP VIEW

N.T.S.

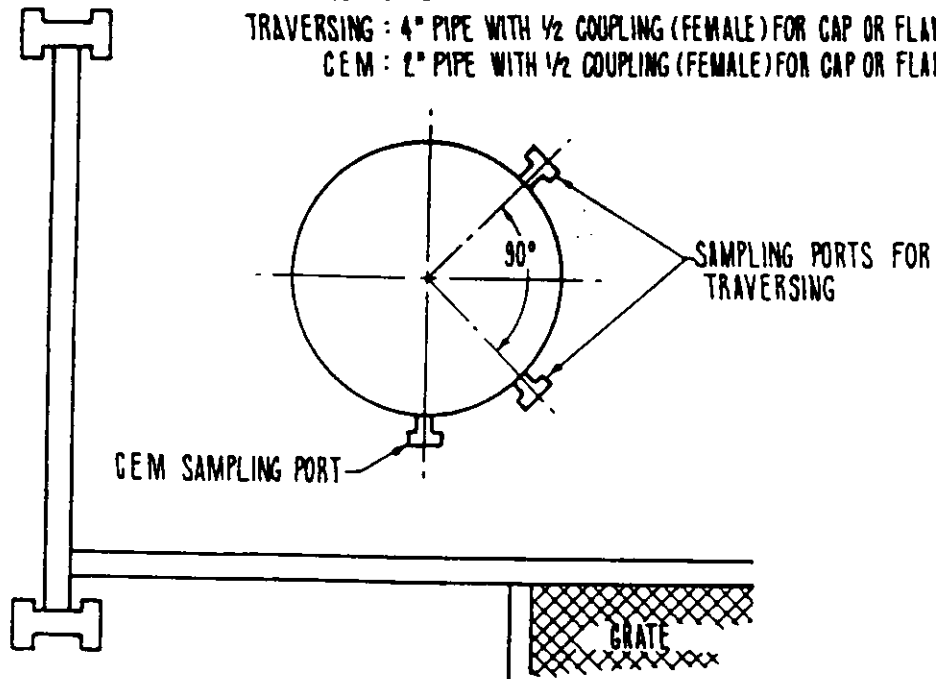

PLAN VIEW

N.T.S.

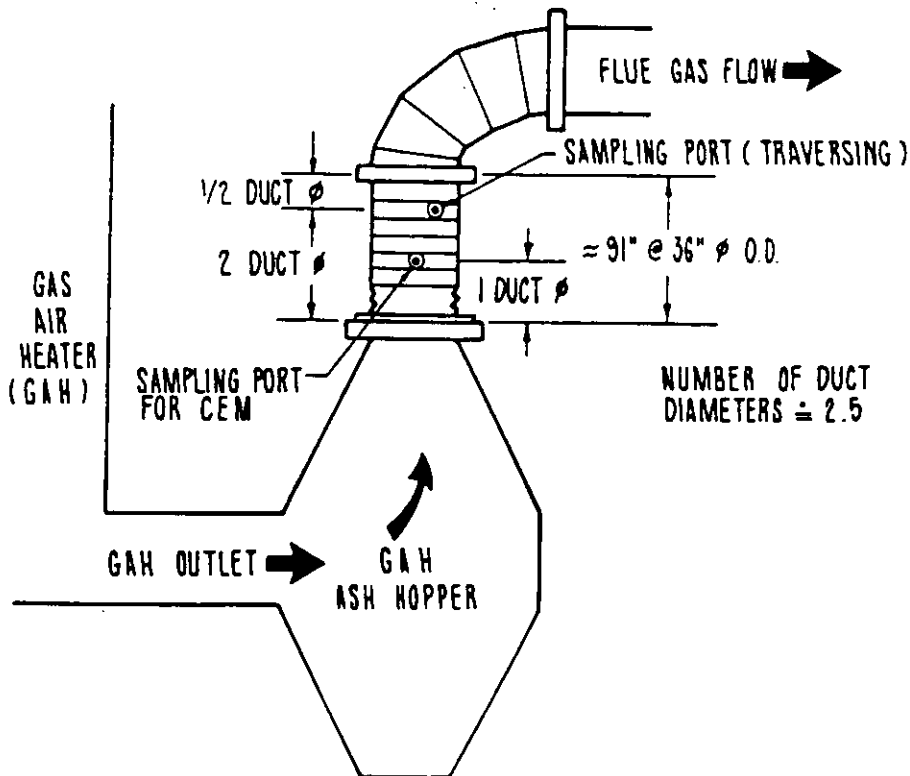

FIGURE 4-3

DIAGRAM OF SAMPLING POINT 2, CYCLONE OUTLET

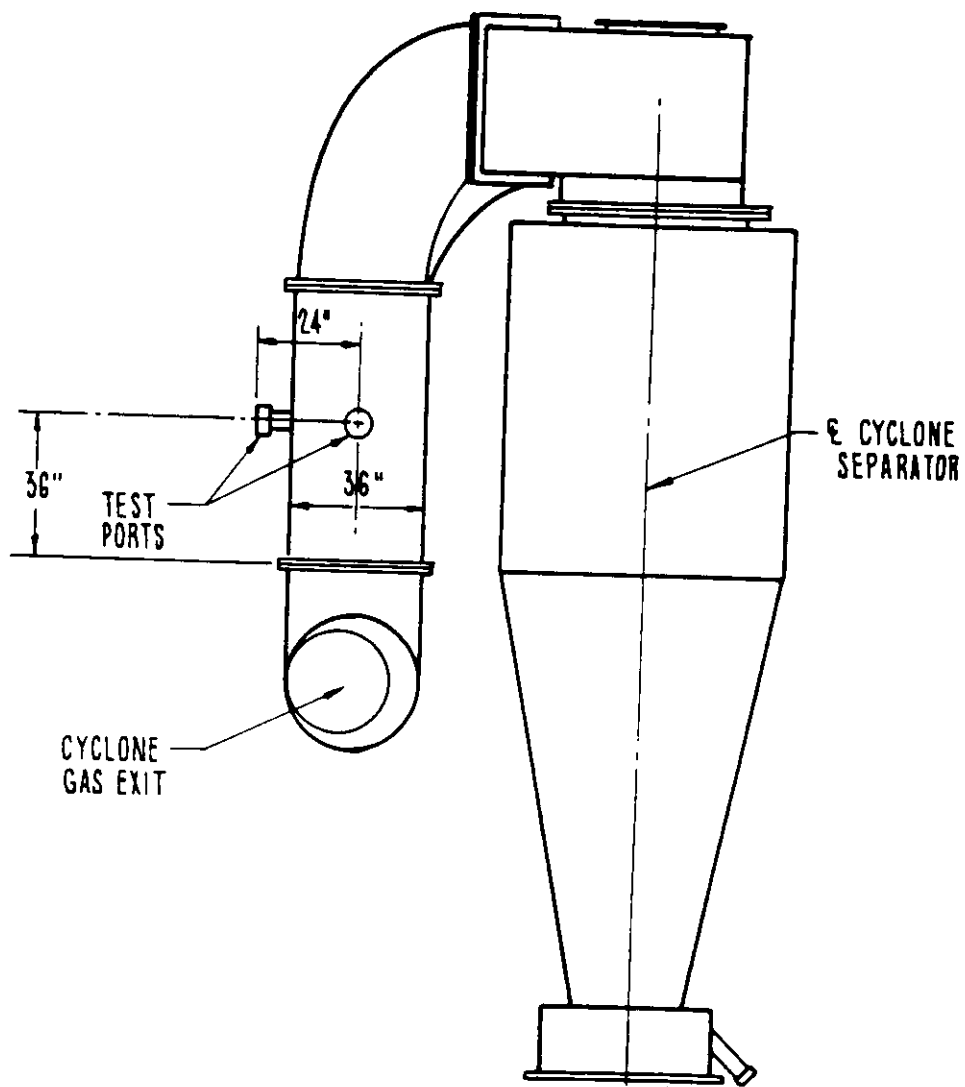
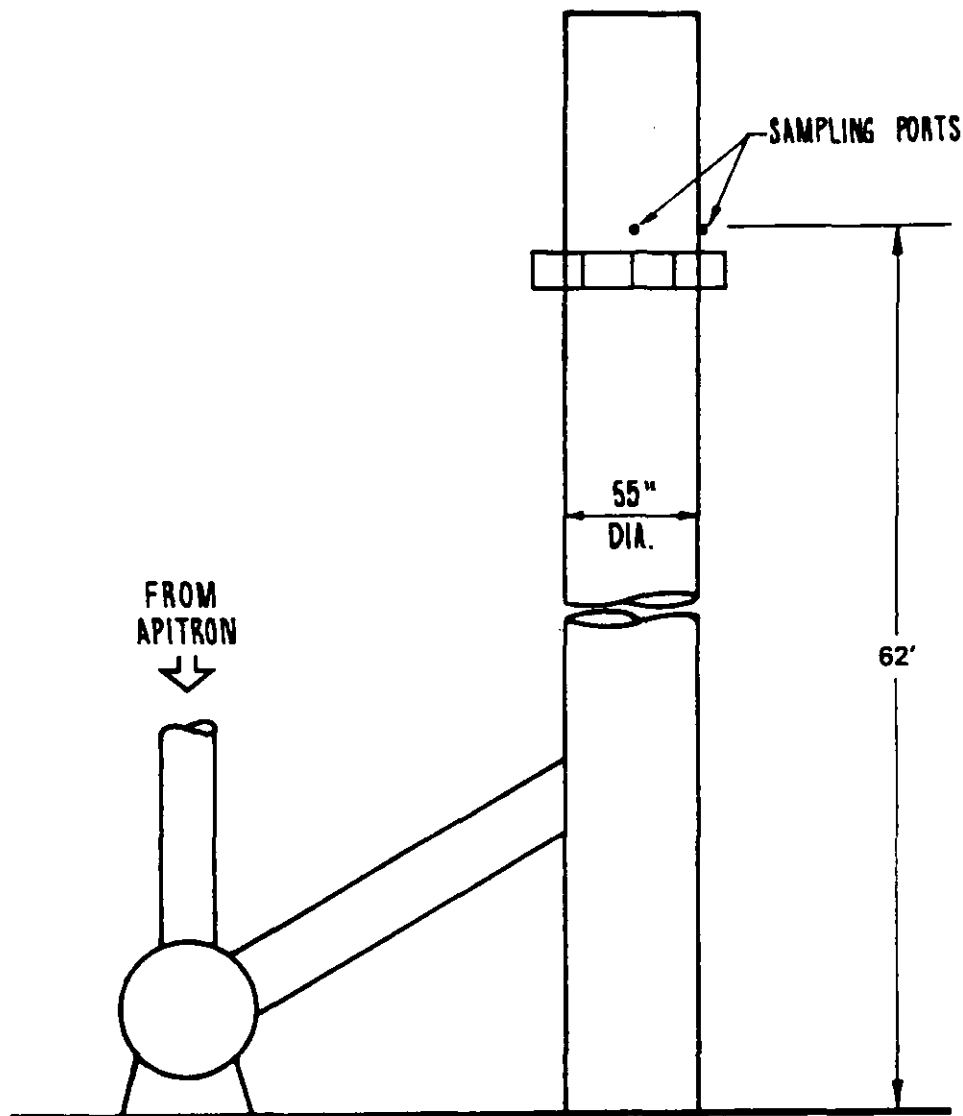



FIGURE 4-4

DIAGRAM OF SAMPLING POINT 1, MAIN STACK



Heavy metals were analyzed by atomic absorption by Brown and Caldwell Environmental Laboratory, Emeryville, California, from samples taken from the particulate catch of each multiclone. The stages of the multiclone were combined, if necessary, to provide approximately 100 milligrams of sample. The concentration of the heavy metals in the various multiclone stages and the final filter, including blanks, are detailed in the Appendix, Part 2. The particulate in the cyclones and the material collected in the condensing section of the multiclone train was analyzed for fluoride by Brown and Caldwell by ion chromatography. The detailed lab sheets are included in the Appendix, Part 2.

The "acid train" was a U.S. EPA Method 6 type train, except that distilled water was used in the impingers. The train was used to determine chloride, fluoride, and ammonia emissions.

Sample points 4 and 5 (on Figure 4-1) are where the samples of MSW and residue, respectively, were taken. The proximate, ultimate and calorific value analyses of the solid waste and residues were performed by Curtis and Tompkins, Ltd., San Francisco, California, in accordance with ASTM Standard Methods D-3172-73, D-3176-74, and D-2015-66 (reapproved 1972), respectively. The sampling and analysis of solid waste did not include separation into the various waste fractions because of cost considerations. After the solid waste was obtained by diverting a crane load from the feed chute, the following sequence was performed: breaking open all the material, mixing thoroughly and then quartering the pile; next the alternate quarters were discarded; the remainder was remixed, quartered again, discarding alternate quarters; the final opposite two quarters were mixed and a 15-20 lb sample was double bagged in plastic and taken to the laboratory. On Tuesday, February 8, 1983, a sample from all four quarters was taken and analyzed to determine the representativeness of each quarter-pile. Residue samples were obtained for laboratory analysis from the combustion residue as it dropped from the ash drag conveyor into the residue bin.

The continuous emissions monitoring was performed by Cooper Engineers in Chemecology's mobile van. The following gases were analyzed using the equipment and methods as follows:

<u>Gas</u>	<u>Analyzer</u>	<u>Analysis Technique</u>
O <sub>2</sub>	Taylor Servomax OA 580	paramagnetic
CO	Infrared Industries IR-702	infrared (NDIR)
CO <sub>2</sub>	" " "	"
NO <sub>x</sub>	Monitor Labs 8430	chemiluminescence
SO <sub>2</sub>	Dupont 400	ultraviolet
NMHC	Byron 401	GC/FID

The sample lines for the monitors were connected to the cyclone outlet on February 6, 1983, and moved to the GAH outlet on February 10, 1983, for the remainder of the test. Each line was directed to a water knockout to prevent condensation in the sample line to the analyzer. A separate heated sample line was used from a GAH outlet sample port to the Byron 401 analyzer.

The original CEM data sheets with calibration notations are included in the Appendix, Part 2.

**SECTION 5**  
**AIR EMISSIONS TEST DATA**  
**AND EMISSION FACTORS**

**SECTION 5**  
**AIR EMISSIONS TEST DATA**  
**AND EMISSION FACTORS**

The results of the air emissions testing, including all the data and emission factors, are contained in this twelve-part section. Each part includes a discussion of the data, relevant tables, and references to the original field data sheets, calculation sheets, and continuous monitoring read-outs contained in the Appendices. The testing procedures were observed by a representative of the U.S. EPA Region IX, and the report is included in the Appendix, Part 3.

**A. SOLID WASTE**

**1. FEED RATE:**

Solid waste was fed to the rotary combustor from one of the two overhead cranes. One overhead crane was equipped with a load cell that recorded the weight of the solid waste dropped into the hopper of the feed chute. The crane operator recorded the time and weight of each load. The crane operator's log is included in the Appendix, Part 4. Only one crane was equipped with a load cell. The crane operators were not able to use the load cell consistently because the bucket on the crane had a tendency to angulate when picking up and dropping the MSW, thus making operation of the bucket difficult. Table 5-1 shows the hourly feed rate and the hourly number of loads.

The load cell weights were averaged to give hourly feed rates. On Thursday and Friday both MSW and NRT were fed to the rotary combustor. Because the load cell was unavailable on Friday, February 11th when feeding MSW, the hourly average for that day for MSW is an average of all the previous hourly MSW load cell readings. The schedule of feeding for MSW and NRT during the two weeks is shown on Table 5-8.

**TABLE 5-1  
AVERAGE HOURLY SOLID WASTE FEED RATE, FEBRUARY 7-11, 1983  
TONS PER HOUR AND CRANE LOAD COUNT**

	Monday 7th		Tuesday 8th		Wednesday 9th		Thursday 10th		Friday 11th		
	Crane Loads	Load Cell (Tons)	Crane Loads	Load Cell (Tons)	Crane Loads	Load Cell (Tons)	Crane Loads	Load Cell (Tons)	Crane Loads	Load Cell (Tons)	
0000	4		3		4		6		5	3.8	NRT
0100	3		5		5		5		5	3.1	
0200	4		4		5		6		3	2.0	
0300	3		4		4		5		5	3.2	
0400	4		4		4		6		6	4.1	
0500	4		4		4		6		5	3.5	
0600	3		4		3		1		4	2.9	
0700	2		4	4.0	4		4		4	3.7	
0800	2		3		5	3.6	4		3,1 <sup>(1)</sup>	2.4	
0900	2	2.1	4		4	3.7	5	5.0	3	MSW	
1000	4	3.9	4		4	4.0	4	2.6	3		
1100	5	5.2	4		3	2.8	4	3.1	4		
1200	3	3.5	3		4	4.0	4	4.2	4		
1300	4	4.6	4		5	4.9	4	3.7	3,1 <sup>(1)</sup>		
1400	3		5		5	4.1	4	3.4	4		NRT
1500	6		6		5	3.2	6	3.9	NRT	5	
1600	4		5		5		5	3.7	5		
1700	5		5		5		4	3.0	7	3.7	MSW
1800	5		5		2		5	3.7	4		
1900	3		5		4		5	3.4	4		
2000	4		5		5		7	4.4	5		
2100	4		4		3		3	2.3	4		
2200	5		5		5		4	3.0	4		
2300	3		3		6		5		5		
2400											
Daily Total											
Crane Loads	89		102		103		111		106		
Hourly Average											
(TPH) MSW:		3.86		4.0		3.79		3.67		No Readings	
(TPH) NRT:								3.41		3.3	
Average Daily											
Input (TPD)		92.64		96.00		90.96		85.7 <sup>(2)</sup>		83.7 <sup>(3)</sup>	

- (1) At 0900, 3 loads of NRT and 1 load of MSW was fed to combustor; and at 1400, 3 loads of MSW and 1 load of NRT was fed to the combustor.
- (2) Average daily input based on 15 hours of MSW and 9 hours of NRT.
- (3) Average daily input based on 11-1/4 hours of MSW at estimated 3.77 TPH and 12-3/4 hours of NRT at 3.3 TPD.

2. FUEL SAMPLING SCHEDULE:

The solid waste was sampled in conjunction with the in-duct testing when possible. The sampling schedule in Table 5-2 shows when a solid waste sample was taken. A solid waste sample was taken during the first five or ten minutes of either a U.S. EPA Method 5 or Method 101 test in order to have fuel analyses to compare to the pollutant sampling.

3. FUEL SAMPLE ANALYSES:

The solid waste that was fed to the rotary combustor during the air emissions testing was analyzed by proximate, ultimate and calorific value analyses in accordance with ASTM Standard Methods. The results of these analyses are shown in Table 5-3. In addition to the as-received solid waste analyses, the preprocessed NRT fuel was also analyzed.

During the second day of testing, unusually high SO<sub>2</sub> concentrations for a waste-to-energy plant were recorded and an abnormal amount of blue photographic chips and asphalt shingles were observed in the feed. Suspicious that the waste from an industrial source high in sulfur was dumped at the plant, the "blue chips" and asphalt shingles were analyzed by proximate, ultimate and calorific value analyses. The results of these analyses are shown in Table 5-4. As can be seen, the sulfur content in these two materials did not contribute significantly to the inexplicable high SO<sub>2</sub> CEM readings that were recorded, see Table 5-28, nor to the high sulfur content of the waste analyzed during Wednesday, February 9, 1983, see Table 5-3.

4. FEED RATE DURING AIR EMISSIONS SAMPLING

The feed rate of MSW or NRT during sampling was used to calculate emission factors in pounds of pollutant per ton of feed. The feed rates were calculated from load cell data averaged during the sampling period, if available, or averaged over the sampling day. When averaging feed rates during the sampling period, the time chosen for start and finish reflected a full feed hopper and chute.

**TABLE 5-2**  
**SOLID WASTE SAMPLING SCHEDULE**  
**February 7-11, 1983**

Monday, February 7

10:42 A.M. Solid waste sample taken for proximate, ultimate and calorific value analyses.

Tuesday, February 8

9:10 to 9:30 A.M. Four solid waste samples from same crane load quartered and taken for proximate, ultimate and calorific value analyses.

10:35 A.M. Solid waste sample taken for proximate, ultimate and calorific value analyses.

11:30 A.M. Solid waste sample taken for proximate, ultimate and calorific value analyses.

1:40 P.M. Solid waste sample taken for proximate, ultimate and calorific value analyses.

5:00 P.M. Solid waste sample taken for proximate, ultimate and calorific value analyses.

Wednesday, February 9

9:50 A.M. Solid waste sample taken for proximate, ultimate and calorific value analyses.

2:00 P.M. Solid waste sample taken for proximate, ultimate and calorific value analyses.

Thursday, February 10

9:10 A.M. Solid waste sample taken for proximate, ultimate and calorific value analyses.

2:10 P.M. Solid waste sample taken for proximate, ultimate and calorific value analyses.

Friday, February 11

4:00 P.M. Solid waste sample processed by NRT taken for proximate, ultimate and calorific value analyses.

4:30 P.M. NRT sample taken for proximate, ultimate and calorific value analyses.



**TABLE 5-3  
CALORIFIC VALUE, PROXIMATE AND ULTIMATE ANALYSES OF SOLID WASTE**

<u>Date &amp; Time Sample Taken</u>		<u>2/7/83 at 1042</u>	<u>2/8 at 0910</u>	<u>2/8 at 0910</u>	<u>2/8 at 0910</u>	<u>2/8 at 0910</u>	<u>2/8 at 1035</u>	<u>2/8 at 1130</u>	<u>2/8/83 at 1340</u>
<u>PROXIMATE ANALYSIS</u>									
<u>Dry Basis</u>									
Higher Heating Value	Btu/lb	7,536	7,039	7,068	7,791	7,077	7,223	7,496	7,603
Moisture (as-received)	%	35.84	30.16	44.39	48.30	46.85	44.82	45.89	28.19
Higher Heating Value (as-received)	Btu/lb	4,835	4,916	3,931	4,028	3,761	3,986	4,041	5,460
Volatile Matter	%	75.21	73.43	72.77	75.40	75.18	72.78	66.26	69.49
Fixed Carbon	%	10.95	4.24	11.82	12.59	7.01	11.25	12.87	11.21
Ash	%	13.84	22.33	15.41	12.01	17.81	15.97	20.87	19.30
<u>ULTIMATE ANALYSIS</u>									
<u>Dry Basis</u>									
Carbon	%	41.74	38.04	39.84	43.57	38.84	39.93	43.43	44.15
Hydrogen	%	5.66	5.34	5.59	5.20	5.67	5.31	5.47	5.84
Nitrogen	%	0.26	<0.10	0.23	<0.10	<0.10	<0.10	<0.10	<0.10
Sulfur	%	0.09	0.85	1.40	0.05	0.14	0.05	0.31	1.10
Ash	%	13.85	22.33	15.41	12.01	17.81	15.97	20.87	19.30
Oxygen (by Difference)	%	38.41	33.44	37.53	39.07	37.54	38.74	29.92	29.61
Chlorine	%	XXXX	XXXX	0.80	XXXX	0.81	0.60	0.50	XXXX
Fluorine	%	XXXX	XXXX	<0.01	XXXX	<0.01	<0.01	0.01	XXXX
Mercury	ppm	0.15	XXXX	0.11	XXXX	<0.1	XXXX	XXXX	XXXX

**TABLE 5-3 (Continued)  
CALORIFIC VALUE, PROXIMATE AND ULTIMATE ANALYSES OF SOLID WASTE**

<u>Date &amp; Time Sample Taken</u>		<u>2/8/83</u> <u>at</u> <u>1700</u>	<u>2/9</u> <u>at</u> <u>0950</u>	<u>2/9</u> <u>at</u> <u>1400</u>	<u>2/10</u> <u>at</u> <u>0910</u>	<u>2/10</u> <u>at</u> <u>1410</u>	<u>2/11/83</u> <u>at</u> <u>1600</u>	<u>Average</u> <u>of all</u> <u>Samples</u>
<u>PROXIMATE ANALYSIS</u>								
<u>Dry Basis</u>								
Higher Heating Value	Btu/lb	7,183	6,899	7,454	7,198	6,757	6,639	7,210
Moisture (as-received)	%	44.14	40.67	38.93	46.81	43.26	43.31	41.54
Higher Heating Value (as-received)	Btu/lb	4,012	4,093	4,552	3,829	3,834	3,764	4,217
Volatile Matter	%	71.42	70.36	59.55	67.43	68.74	67.97	70.43
Fixed Carbon	%	10.43	NIL	3.39	12.05	9.88	13.86	9.40
Ash	%	18.15	31.37	37.06	20.52	21.38	18.17	20.30
<u>ULTIMATE ANALYSIS</u>								
<u>Dry Basis</u>								
Carbon	%	40.25	30.44	38.58	40.66	36.59	44.97	40.07
Hydrogen	%	5.53	4.76	5.60	5.30	5.40	5.51	5.45
Nitrogen	%	<0.10	0.17	<0.10	0.86	1.04	0.35	<0.27
Sulfur	%	0.70	5.10	2.40	1.90	1.84	0.97	1.21
Ash	%	18.15	31.37	37.06	20.52	21.38	18.17	20.30
Oxygen (by Difference)	%	35.37	28.26	16.36	30.76	33.75	30.03	32.77
Chlorine	%	XXXX	0.55	0.20	0.32	XXXX	XXXX	0.53
Fluorine	%	XXXX	<0.01	<0.01	<0.01	XXXX	XXXX	<0.01
Mercury	ppm	XXXX	0.16	XXXX	XXXX	XXXX	XXXX	0.13

**TABLE 5-4  
CALORIFIC VALUE, PROXIMATE AND ULTIMATE ANALYSES OF UNUSUAL FUEL  
CONSTITUENTS (SHINGLES AND BLUE PHOTOGRAPHIC CHIPS)**

<u>Date and Time Sample Taken</u>		<u>2/9/83 at 0950</u>	<u>2/9/83 at 1040</u>	<u>2/9/83 at 1040</u>
<b><u>PROXIMATE ANALYSIS</u></b>				
<b><u>Dry Basis</u></b>				
		<b><u>Blue Chips</u></b>	<b><u>Blue Chips</u></b>	<b><u>Shingles</u></b>
Higher Heating Value	Btu/lb	5,852	8,780	7,008
Moisture (as-received)	%	17.54	21.05	NIL
Higher Heating Value (as received)	Btu/lb	4,826	6,932	7,008
Volatile Matter	%	58.04	85.84	45.39
Fixed Carbon	%	4.26	9.57	3.62
Ash	%	37.70	4.59	50.99
<b><u>ULTIMATE ANALYSIS</u></b>				
<b><u>Dry Basis</u></b>				
Carbon	%	43.09	60.61	43.39
Hydrogen	%	3.21	4.10	5.39
Nitrogen	%	<0.10	<0.10	0.10
Sulfur	%	0.81	0.85	0.08
Ash	%	37.70	4.59	50.99
Oxygen (by Difference)	%	15.19	29.85	0.05
Chlorine	%	0.51	0.53	0.40
Fluorine	%	XXXX	XXXX	XXXX
Mercury	ppm	XXXX	XXXX	XXXX

B. RESIDUE

The residue, like the solid waste, was sampled during the in-duct sampling; however, the residue was taken approximately one-half hour after the solid waste sample. The residue consisted of both boiler bottom ash and flue gas fly ash that had been collected and placed in the quench tank. The sampling schedule is shown in Table 5-5.

The residue was collected in 8-ounce jars as it fell from the ash drag conveyor into the residue bin. The residue was analyzed by proximate, ultimate and calorific analyses as shown in Table 5-6.

The amount of residue that was collected each day was calculated from the truck drivers log of bin weights that were taken daily before the residue went to the landfill, as shown in Table 5-7. A copy of the log is contained in the Appendix, Part 4. The residue samples that were collected include a significant amount of water carried over from the quench tank. During later testing of the amount of water taken to the landfill by RASCO, approximately 2100 pounds of free standing water was emptied through a bung hole placed in the bottom of a residue bin.

**TABLE 5-5  
RESIDUE SAMPLING SCHEDULE  
February 7-11, 1983**

Monday, February 7

11:20 A.M. Residue sample taken for proximate, ultimate and calorific value analyses.

Tuesday, February 8

10:15 A.M. Residue sample taken for proximate, ultimate and calorific value analyses.

2:40 P.M. Residue sample taken for proximate, ultimate and calorific value analyses.

5:20 P.M. Residue sample taken for proximate, ultimate and calorific value analyses.

Wednesday, February 9

10:20 A.M. Residue sample taken for proximate, ultimate and calorific value analyses.

2:20 P.M. Residue sample taken for proximate, ultimate and calorific value analyses.

Thursday, February 10

9:20 A.M. Residue sample taken for proximate, ultimate and calorific value analyses.

2:20 P.M. Residue sample taken for proximate, ultimate and calorific value analyses.

Friday, February 11

4:30 P.M. Residue sample taken for proximate, ultimate and calorific value analyses.

**TABLE 5-6  
CALORIFIC VALUE, PROXIMATE AND ULTIMATE ANALYSES OF RESIDUE**

<u>Date &amp; Time Sample Taken</u>		<u>2/7/83 at 1120</u>	<u>2/8 at 1015</u>	<u>2/8 at 1440</u>	<u>2/8 at 1720</u>	<u>2/9/83 at 1020</u>
<b><u>PROXIMATE ANALYSIS</u></b>						
<b><u>Dry Basis</u></b>						
Higher Heating Value	Btu/lb	606	1,819	4,057	482	2,837
Moisture (as-received)	%	38.26	62.20	80.95	22.73	76.79
Higher Heating Value (as-received)	Btu/lb	374	688	773	372	658
Volatile Matter	%	8.63	19.40	11.49	5.25	13.23
Fixed Carbon	%	NIL	NIL	22.49	NIL	12.77
Ash	%	92.28	81.43	66.02	95.18	74.00
<b><u>ULTIMATE ANALYSIS</u></b>						
<b><u>Dry Basis</u></b>						
Carbon	%	4.27	14.06	26.73	2.44	19.58
Hydrogen	%	0.22	0.40	0.62	0.07	0.40
Nitrogen	%	<0.10	<0.10	<0.10	<0.10	<0.10
Sulfur	%	0.05	1.11	<0.01	<0.01	<0.01
Ash	%	92.28	81.43	66.02	95.18	74.00
Oxygen (by Difference)	%	3.18	3.00	6.63	2.31	5.79
Chlorine	%	XXXX	XXXX	XXXX	XXXX	1.48
Fluorine	%	XXXX	XXXX	XXXX	XXXX	0.014
Mercury	ppm	0.15	0.14	XXXX	XXXX	30 <sup>(1)</sup>

(1) Mercury sample taken 2/9 at 1020 not included in the average.

TABLE 5-6 (Continued)  
CALORIFIC VALUE, PROXIMATE AND ULTIMATE ANALYSES OF RESIDUE

<u>Date &amp; Time Sample Taken</u>		<u>2/9/83</u> <u>at</u> <u>1420</u>	<u>2/10</u> <u>at</u> <u>0920</u>	<u>2/10</u> <u>at</u> <u>1440</u>	<u>2/11/83</u> <u>at</u> <u>1630</u>	<u>AVERAGE</u>
<u>PROXIMATE ANALYSIS</u>						
<u>Dry Basis</u>						
Higher Heating Value	Btu/lb	3,412	1,874	3,048	1,121	2,140
Moisture (as-received)	%	80.01	60.23	71.21	40.05	59.16
Higher Heating Value (as-received)	Btu/lb	682	745	878	672	649
Volatile Matter	%	11.80	8.73	10.78	8.66	10.89
Fixed Carbon	%	18.21	6.59	16.81	NIL	8.54
Ash	%	69.99	84.68	72.41	91.41	80.82
<u>ULTIMATE ANALYSIS</u>						
<u>Dry Basis</u>						
Carbon	%	23.87	11.76	21.99	9.27	14.89
Hydrogen	%	0.46	0.29	0.47	0.46	0.38
Nitrogen	%	<0.10	<0.10	<0.10	<0.10	<0.10
Sulfur	%	0.09	1.00	0.07	0.21	0.38
Ash	%	69.99	84.68	72.41	90.41	80.82
Oxygen (by Difference)	%	5.59	2.27	4.43	NIL	3.69
Chlorine	%	1.17	0.98	XXXX	XXXX	1.21
Fluorine	%	<0.01	<0.01	XXXX	XXXX	<0.011
Mercury	ppm	XXXX	XXXX	XXXX	XXXX	0.15 <sup>(1)</sup>

(1) Mercury sample taken 2/9 at 1020 not included in the average.

**TABLE 5-7  
RESIDUE COLLECTION(1)  
February 7-11, 1983**

**Monday, February 7, 1983**

56.2 Tons Collected

**Tuesday, February 8, 1983**

46.7 Tons Collected

**Wednesday, February 9, 1983**

47.4 Tons Collected

**Thursday, February 10, 1983**

42.2 Tons Collected

**Friday, February 11, 1983**

41.5 Tons Collected

---

(1) Residue collected in bins weighing approximately 14 tons.



C. OPERATION OF THE ROTARY COMBUSTOR

1. OPERATING SCHEDULE:

The operating schedule of Unit #1 is shown in Table 5-8. This table shows whether MSW or NRT was burned, the hours the unit was running and the hours that the CEM were recording data.

2. NET HEAT INPUT:

The net heat input to the combustor can be calculated as the difference between the as-received MSW heat input, Table 5-3, and the remaining residue heat value, Table 5-6. This difference is shown in Table 5-9, coinciding to the approximate times of MSW and residue sampling. The average net heat input to the system was  $29.01 \times 10^6$  Btu/hr for the period of February 7-11, 1983.

3. WEIGHT REDUCTION FOR THE ROTARY COMBUSTOR:

The weight of the solid waste reduced by the O'Connor Rotary Combustor on a wet and dry basis is shown in Table 5-10. The results show that the waste is reduced by 79% on a dry basis and 48% on a wet basis. RASCO does not pay by total weight for the residue taken to the landfill; therefore, the plant operators were not concerned about hauling the additional water added to the residue from the quench tank.

4. PROCESS DATA:

Process data for the rotary combustor/boiler was recorded during the testing period by instrumentation in the facility control room, as part of the normal plant operation. Instrumentation continuously monitors the steam flow, air flow, boiler outlet % O<sub>2</sub> (wet), steam temperature and pressure and temperatures throughout the combustion equipment and records these data on strip charts.

Cooper Engineers processed these data into five-minute increments to match the CEM increments over the entire two week testing period for evaluation. The data can be found in the Appendix, Part 2.

**TABLE 5-8  
 COMBUSTOR OPERATING SCHEDULE, FEBRUARY 7-21, 1983  
 AND CONTINUOUS EMISSIONS MONITORING (CEM) HOURS OF OPERATION**

Date	Boiler Operating Hours		CEM Hours			
	Fuel	Hours Unit Up	Hours Unit Down	Typical Operations Usable Date	Plant Operational But CEM Data Not Usable	Data Taken During Conditions of Plant Upset, Startup, Shutdown and Unusual Fuels
2-7	MSW	0900-2235 2240-2400	2235-2240	1200-2235 2240-2300	2300-2400	0900-1200
2-8	MSW	0000-2400		0835-1025 1105-2400	0000-0835 1025-1105	
2-9	MSW	0000-1855 1920-2400	1855-1920	0000-1800 1920-2045	1800-1855 SO <sub>2</sub> Data	2045-2400
2-10	MSW NRT 0000-1500 1500-2400	0000-2400		0000-0830	0800-0830 2050-2400	0000-0820 SO <sub>2</sub> Data
2-11	MSW NRT 0840-1450 1450-2400	0000-2400		0020-0200 0250-2400	000-0020	0200-0250
2-12	MSW	0000-2400		0000-2400		
2-13	MSW	0000-1445	1445-2400	0000-1445		

**TABLE 5-8 (Continued)  
COMBUSTOR OPERATING SCHEDULE, FEBRUARY 7-21, 1983  
AND CONTINUOUS EMISSIONS MONITORING (CEM) HOURS OF OPERATION**

Date	Boiler Operating Hours		CEM Hours			
	Fuel	Hours Unit Up	Hours Unit Down	Typical Operations Usable Date	Plant Operational But CEM Data Not Usable	Data Taken During Conditions of Plant Upset, Startup, Shutdown and Unusual Fuels
2-14	MSW NRT 0850- 0800- 2400 0850	0830-2400	0000-0830	1200-2400	0830-1200	
2-15	MSW 0710- 0000- 1520 0710 1520- 2400	NRT	0000-2400		0000-2400	
2-16	NRT	0000-0925	0925-2400	0000-0640		0640-0925
2-17	NRT	1945-2245	0000-1945 2245-2400			1945-2245
2-18	MSW NRT 0045- 0700- 0700 1600	0045-1600	0000-0045 1600-2400			0045-1600
2-19	MSW	2245-2400	0000-2245		2245-2400	
2-20	MSW NRT 0910- 0000- 2400 0910	0000-1645 1910-2400	1645-1910	1405-1645	0000-1405 1910-1940	1940-2400
2-21	MSW	0000-0800				0000-0800

**TABLE 5-9  
AVERAGE NET MSW HEAT INPUT RATE**

<u>Date</u>	<u>Approximate MSW and Residue Sample Time</u>	<u>MSW HHV (as rec'd), Btu/lb</u>	<u>MSW Feed Rate, TPH</u>	<u>MSW Heat Input, 10<sup>6</sup> Btu/hr</u>	<u>Residue HHV (as rec'd), Btu/lb</u>	<u>Residue Collection Rate, TPH</u>	<u>Residue Heat Rate 10<sup>6</sup> Btu/hr</u>	<u>NET Heat Rate 10<sup>6</sup> Btu/hr</u>
2-7	1000 to 1200	4,835	3.86	37.33	374	2.34	1.75	35.58
2-8	0900 to 1030	4,159	4.0	33.27	688	1.95	2.68	30.59
	1030 to 1500	4,496	4.0	35.97	773	1.95	3.01	32.96
	1600 to 1730	4,012	4.0	32.10	372	1.95	1.45	30.65
2-9	0900 to 1100	4,093	3.79	31.02	658	1.98	2.61	28.41
	1400 to 1500	4,552	3.79	34.50	682	1.98	2.70	31.80
2-10	0900 to 1000	3,829	3.67	28.10	745	1.76	2.62	25.48
	1400 to 1500	3,834	3.67	28.14	878	1.76	3.09	25.05
2-11	1600 to 1700	3,764	3.3 (NRT)	24.84	672	1.73	2.33	22.51
<b>AVERAGE</b>		<b>4,217<sup>(1)</sup></b>	<b>3.74<sup>(1)</sup></b>	<b>31.54</b>	<b>649<sup>(1)</sup></b>	<b>1.95<sup>(1)</sup></b>	<b>2.53</b>	<b>29.01</b>

(1) Weighted averages from Tables 5-3, 5-1, 5-6 and 5-7, respectively.

**TABLE 5-10**  
**AVERAGE SOLID WASTE WEIGHT REDUCTION**  
February 7-11, 1983

<u>Date</u>	<u>Average MSW Input, TPD</u>	<u>Average Moisture, %</u>	<u>Average<sup>(1)</sup> Residue Collected, TPD</u>	<u>Average Moisture, %</u>	<u>Percent Reduction Wet Ash Basis</u>	<u>Percent Reduction Dry Ash Basis</u>
2-7	92.64	35.84	56.2	38.26	39.3	62.5
2-8	96.0	41.59	46.7	55.29	51.4	78.3
2-9	90.96	38.80	47.4	78.40	47.9	88.7
2-10	85.7	45.04	42.2	65.72	50.8	83.1
2-11	83.7	43.31	41.5	40.05	50.4	70.3
Daily Avg.	89.8	41.54	46.8	59.16	47.9	78.7

(1) Residue collected based on collection container weight of 14 tons.

D. FLUE GAS DATA

1. FLUE GAS FLOW RATE:

The data from the sampling for mercury, particulate and SO<sub>2</sub>/SO<sub>3</sub> include several data sets on the flue gas flow characteristics from the rotary combustor/boiler. The data are presented in Table 5-11 giving average velocity and flow rates at the combustor outlet (the GAH), the Apitron outlet (the stack), and the cyclone outlet. Velocity and flow rate data were also taken during the aerodynamic particle size distribution sampling with the Andersen cascade impactor and the multiclones but were not used in the averages because they represent single point samples. The flow rate data for all the testing may be found in the Appendix, Part 2.

The flow rates presented in Table 5-11 indicate that the flow rates at standard conditions are about 40% higher at the Apitron outlet than the rotary combustor outlet. Dilution air can possibly account for about 20% higher flow, as shown in Table 5-12. When the rotary combustor outlet data are compared to that predicted by the U.S. EPA F-factor (as discussed in Subsection 5.D.3 below), the difference was only 4%, as shown in Table 5-13. Therefore, the flow data at the combustor outlet appears to be accurate and the 20% difference between the combustor outlet and the Apitron could have been from flow measurement error, i.e., a pitot tube error at the Apitron outlet.

2. O<sub>2</sub> AND CO<sub>2</sub>

Table 5-14 shows a comparison of O<sub>2</sub> and CO<sub>2</sub> data between the continuous emissions monitor and Orsat readings taken at approximately equivalent times. The readings appear to be similar but with no high or low pattern comparison. The best of these data were used to correct the pollutant concentrations to 7% O<sub>2</sub> or 12% CO<sub>2</sub>, whichever was appropriate.

3. U.S. EPA F-FACTORS

The U.S. EPA describes F-factors (see 40 CFR 60.45) as ratios of the standard flue gas volume released during combustion of a fuel divided by the heat content of that fuel. A dry F-factor (Fd) is the ratio of the standard dry volume of flue gases generated to the dry gross calorific value of the fuel combusted.

$$Fd = \frac{10^6 (3.64 (\%H) + 1.53 (\%C) + 0.57 (\%S) + 0.14 (\%N) - 0.46 (\%O))}{GCV}$$

**TABLE 5-11**  
**VELOCITIES, FLOW RATES AND DUCT TEMPERATURES/PRESSURES**

Location	Date & Time	Average Velocity FPS	% O <sub>2</sub>	Flow Rates				
				ACFM	at	T <sup>o</sup> F P <sup>"</sup> Hg	SCFM <sup>(1)</sup> SDCFM	SDCFM at 7% O <sub>2</sub>
Combustor Outlet	2/6/83 at 1310	45.6	4.6	18,189		470 29.08	10,227 8,529	10,002
Combustor Outlet	2/7/83 at 1050	45.4	9.0	18,730		434 29.33	10,648 9,098	7,789
Combustor Outlet	2/8/83 at 0855	46.2	10.2	19,044		425 29.33	10,967 9,508	7,091
Combustor Outlet	2/8/83 at 1320	46.2	10.6	19,037		420 29.33	11,032 9,508	7,045
Combustor Outlet	2/8/83 at 1647	47.0	12.8	19,370		422 29.33	11,199 9,416	5,487
Combustor Outlet	2/9/83 at 0940	43.6	8.7	17,999		432 29.15	10,224 8,640	7,583
Combustor Outlet	2/11/83 at 1552	<u>46.7</u>	8.6	<u>19,244</u>		474 29.12	10,429 8,773	7,763
	AVERAGES	45.8		18,292		—	10,675 9,025	7,537
Apitron Outlet	2/8/83 at 1321	24.8	10.0	24,519		328 29.54	15,974 13,684	10,731
Apitron Outlet	2/8/83 at 1648	25.3	11.9	24,998		336 29.54	16,116 13,774	8,918
Apitron Outlet	2/9/83 at 0830	23.2	10.2 <sup>(2)</sup>	22,931		338 29.36	14,667 12,535	9,649
Apitron Outlet	2/11/83 at 1556	<u>23.4</u>	9.5	<u>23,155</u>		363 29.33	14,336 12,265	10,059
	AVERAGES	24.2		23,901 <sup>(3)</sup>		—	15,278 13,065	9,839
Cyclone Outlet	2/6/83 at 1330	50.1	4.6 <sup>(2)</sup>	20,688		451 29.08	11,462 9,559	11,209

(1) Standard conditions = 60°F and 29.92" Hg

(2) Assumed by Chemecology in calculating flow rates prior to testing.

(3) Higher ACFM at the outlet due to air leak at open flange at the Apitron inlet or some spacial and temporal differences in velocity measurement, i.e., pitot tube.

**TABLE 5-12**  
**FLOW RATES CORRECTED TO CEM AND ORSAT OXYGEN**

<u>Date &amp; Time</u>	<u>% O<sub>2</sub> (1)</u>		<u>Flow Rates</u>			<u>SDCFM AT 7% O<sub>2</sub> Apitron Outlet</u>
	<u>ORSAT</u>	<u>CEM</u>	<u>Combustor Outlet SDCFM</u>	<u>Combustor Outlet SDCFM at 7% O<sub>2</sub></u>		
				<u>Orsat</u>	<u>CEM</u>	
2/7/83 1050 to 1437	9.0	9.9	9,098	7,789	7,200	
2/8/83 0855 to 1130	10.2	9.5	9,212	7,091	7,555	
1320 to 1500	10.6	8.2	9,508	7,045	8,687	10,731
1647 to 1825	12.8	9.7	9,416	5,487	7,587	8,918
2/9/83 0940 to 1215	8.7	10.2	8,640	7,583	6,651	
2/11/83 1552 to 1735	8.6	7.6	8,773	7,763	8,394	10,059
<b>AVERAGES (2)</b>				<b>7,126</b>	<b>8,223</b>	<b>9,903</b>

(1) Data from Table 5-14.

(2) Averages only include comparable data.



**TABLE 5-13**  
**FLOW RATES BASED ON U.S. EPA F-FACTORS**

<u>Date &amp; Time</u>	<u>F<sub>d</sub><sup>(1)</sup></u>	<u>Net<sup>(2)</sup> Heat Rate 10<sup>6</sup> Btu/hr</u>	<u>SDCFM at Combustor Outlet by U.S. EPA F-Factor</u>		<u>SDCFM at Combustor Outlet<sup>(3)</sup></u>
			<u>At 0% O<sub>2</sub> and 68<sup>o</sup>F</u>	<u>At 7% O<sub>2</sub> and 60<sup>o</sup>F</u>	<u>At 7% O<sub>2</sub></u>
2/7/83 1050 to 1437	8,875	35.58	5,263	7,793	7,789
2/8/83 0855 to 1150	9,019	30.59	4,598	6,809	7,091
1320 to 1500	9,973	32.96	5,479	8,113	7,045
1647 to 1823	9,118	30.65	4,683	6,934	5,487
2/9/83 0940 to 1215	7,803	28.41	3,695	5,472	7,583
2/11/83 1552 to 1735	<u>11,395</u>	<u>22.51</u>	<u>4,275</u>	<u>6,331</u>	<u>7,763</u>
<b>AVERAGE</b>	9,372			6,909	7,126

**NOTES:**

- (1) Data from Section V, Subsection D.3
- (2) Data from Table 5-9
- (3) Data from Table 5-11

**TABLE 5-14**  
**COMPARISON OF OXYGEN AND CARBON DIOXIDE**  
**READINGS TAKEN DURING SAMPLING BY**  
**ORSAT AND CEM**

<u>Date and Time</u>	<u>ORSAT (% dry)</u>		<u>CEM (% dry)</u>	
	<u>O<sub>2</sub></u>	<u>CO<sub>2</sub></u>	<u>O<sub>2</sub></u>	<u>CO<sub>2</sub></u>
2/7/83 1050 to 1437	9.0	10.5	9.9	10.3
2/8/83 0855 to 1130	10.2	9.0	9.5	10.3
1320 to 1500	10.6	9.6	8.2	11.1
1647 to 1825	12.8	7.7	9.7	10.5
2/9/83 0940 to 1215	8.7	11.3	10.2	9.8
2/11/83 1552 to 1735	8.6	11.2	7.6	12.6

Using the fuel analysis data shown in Table 5-3 for the times when representative flow rates were calculated (shown in Table 5-11), the following F-factors were calculated:

	<u>Fd</u> <u>(scf/10<sup>6</sup> Btu)</u>
2/7/83 1050 to 1437	8,875
2/8/83 0855 to 1150	9,019
1320 to 1500	9,973
1647 to 1825	9,168
2/9/83 0940 to 1215	7,803
2/11/83 1552 to 1735	<u>11,395</u>
AVERAGE	9,372

## E. PARTICULATE

### 1. EMISSION RATE AND EMISSION FACTORS

Particulates were sampled at the outlet to the rotary combustor, cyclone and Apitron. Table 5-15 shows the particulate loadings and control efficiencies and whether the U.S. EPA Method 5 or Method 5/8 train was used during the representative sampling period. The data sheets from the sampling may be found in the Appendix, Part 2.

A grain loading at 12% CO<sub>2</sub> and an emission rate in lb/hr were calculated both with and without condensibles, i.e., the impinger catch or "back half". Table 5-15 shows that the U.S. EPA would consider the cyclone to be 80.2% efficient and the cyclone and Apitron to have an overall efficiency of 98.4%. The Gallatin system complied with the plant's State of Tennessee Air Permit condition of 0.04 gr/SDCF at 12% CO<sub>2</sub>.

The emission rates were converted to emission factors using the feed rates in tons per hour or 10<sup>6</sup> Btu/hr that corresponded to the representative sampling time periods. The unabated emission rates presented in Table 5-16 are 42.5 lb/ton and 5.35 lb/10<sup>6</sup> Btu using U.S. EPA sampling methods. The U.S. EPA F-factor method (Table 5-17) gives emission factors of 51.2 lb/ton and 6.45 lb/10<sup>6</sup> Btu. It also gives the cyclone and Apitron system a 99.0% removal efficiency.

### 2. PARTICLE SIZE DISTRIBUTION:

Particle size distribution samplings were performed using the Andersen in-stack cascade impactor and the Flowsensor in-stack five-stage Multiclone. Four samples from each instrument were taken at the combustor outlet and the results are shown in Tables 5-18 and 5-19 for the cascade impactor and multiclone, respectively. Two Apitron outlet samples were taken with the Andersen and their results are presented in Table 5-20. The fractional weights and other sampling data are presented in the Appendix, Part 2. The Apitron was the most efficient (99.8%) on removing the greater than 20 micron particles (see Table 5-21). The overall removal efficiency was 98.4%.

**TABLE 5-15  
PARTICULATE LOADINGS**

<u>Date &amp; Time</u>	<u>U.S. EPA Sampling Method</u>	<u>gr/SDCF</u>		<u>gr/SDCF at 12% CO<sub>2</sub></u>		<u>lb/hr SCAQMD &amp; Other Calif</u>	<u>lb/hr BAAQMD &amp; U.S. EPA</u>
		<u>With Condensibles</u>	<u>Without Condensibles</u>	<u>With Condensibles</u>	<u>Without Condensibles</u>		
<b>Combustor Outlet:</b>							
2/8/83 1321 to 1500	5/8	2.2010	2.2006	2.75125	2.75075	179.55	179.52
2/8/83 1647 to 1825	5/8	1.9861	1.9860	3.0952	3.0951	160.46	160.45
2/11/83 <sup>(1)</sup> 1552 to 1735	5	—	<u>1.8678</u>	—	<u>2.0012</u>	—	<u>140.5</u>
<b>AVERAGE</b>		<b>2.094</b>	<b>2.093</b>	<b>2.923</b>	<b>2.923</b>	<b>170.0</b>	<b>170.0</b>
<b>Cyclone Outlet:</b>							
2/11/83 1553 to 1734	5	0.440	0.392	0.4933	0.4356	36.6	32.6
<b>Average Control Efficiency (Cyclone only), %</b>						<b>78.47</b>	<b>80.82</b>
<b>Apitron Outlet:</b>							
2/8/83 1332 to 1507	5/8	0.0294	0.0264	0.03564	0.03200	3.45	3.10
2/8/83 1648 to 1830	5/8	0.0233	0.0201	0.03728	0.03216	2.75	2.38
2/11/83 <sup>(1)</sup> 1554 to 1744	5	—	<u>0.0173</u>	—	<u>0.02035</u>	—	<u>1.82</u>
<b>AVERAGE</b>		<b>0.0264</b>	<b>0.0233</b>	<b>0.0365</b>	<b>0.0321</b>	<b>3.10</b>	<b>2.74</b>
<b>Average Control Efficiency, %</b>						<b>98.18</b>	<b>98.39</b>

West County Agency of Contra Costa County  
Waste Co-Disposal/Energy Recovery Project

July, 1984

(1) Not included in averages.

**TABLE 5-16  
PARTICULATE EMISSION FACTORS**

Date and Time	Emission Factors							
	lb/hr		Feed Rate		lb/ton		lb/10 <sup>6</sup> Btu	
	SCAQMD Other Calif.	BAAQMD U.S. EPA	TPH	10 <sup>6</sup> Btu/hr	SCAQMD Other Calif.	BAAQMD U.S. EPA	SCAQMD Other Calif.	BAAQMD U.S. EPA
Combustor Outlet								
2/8/83	179.55	179.52	4.0	32.96	44.9	44.9	5.45	5.45
1321 to 1500								
2/8/83	160.46	160.45	4.0	30.65	40.1	40.1	5.24	5.24
1647 to 1825								
2/11/83 <sup>(1)</sup>	—	140.45	3.3	22.51	—	42.6	—	6.24
1552 to 1735								
AVERAGE	170.0	170.0			42.5	42.5	5.35	5.35
Cyclone Outlet:								
2/11/83	36.6	32.6	3.3	22.51	11.1	9.88	1.63	1.45
1553 to 1734								
Apitron Outlet:								
2/8/83	3.45	3.10	4.0	32.96	0.863	0.775	0.105	0.0941
1322 to 1507								
2/8/83	2.75	2.38	4.0	30.65	0.688	0.595	0.0897	0.0777
1648 to 1830								
2/11/83 <sup>(1)</sup>	—	1.82	3.3	22.51	—	0.552	—	0.0809
1554 to 1744								
AVERAGE	3.10	2.74			0.766	0.685	0.0974	0.0859

(1) Not included in averages.

**TABLE 5-17  
PARTICULATE LOADINGS AND PARTICULATE EMISSIONS BASED ON U.S. EPA F-FACTORS**

Date & Time	F-Factor SDCFM at 0% O <sub>2</sub> & 60°F	Duct % O <sub>2</sub>	F-Factor SDCFM at duct % O <sub>2</sub>	gr/SDCF		lb/hr		EMISSION FACTORS			
				With cond.	Without cond.	With cond.	Without cond.	lb/ton		lb/10 <sup>6</sup> Btu	
								SCAQMD Other CA	BAAQMD U.S. EPA	SCAQMD Other CA	BAAQMD U.S. EPA
<b>Combustor Outlet:</b>											
2/8/83											
1320 to 1500	5,396	10.6	10,949	2.2010	2.2006	206.8	206.7	51.7	51.7	6.27	6.27
1647 to 1825	4,612	12.8	11,900	<u>1.9861</u>	<u>1.9860</u>	<u>202.8</u>	<u>202.8</u>	<u>50.7</u>	<u>50.7</u>	<u>6.62</u>	<u>6.62</u>
AVERAGE				2.094	2.093	204.8	204.8	51.2	51.2	6.45	6.45
<b>Apitron Outlet:</b>											
2/8/83											
1322 to 1507	5,396	10.0	10,346	0.0294	0.0264	2.610	2.344	0.653	0.586	0.079	0.071
1648 to 1830	4,612	11.9	10,710	<u>0.0233</u>	<u>0.0201</u>	<u>2.141</u>	<u>1.847</u>	<u>0.535</u>	<u>0.462</u>	<u>0.070</u>	<u>0.060</u>
				0.0264	0.0233	2.376	2.096	0.594	0.524	0.075	0.066

**TABLE 5-18**  
**COMBUSTOR OUTLET PARTICLE SIZE DISTRIBUTION**  
**By Andersen In-Stack Sampler**

DATE AND TIME	2/9/83 1400 to 1405		2/9/83 1544 to 1559		2/10/83 0855 to 0904		2/10/83 1217 to 1226	
	<u>u</u>	<u>wt %</u>	<u>u</u>	<u>wt %</u>	<u>u</u>	<u>wt %</u>	<u>u</u>	<u>wt %</u>
PARTICLE: SIZING	<0.8	5.19	<0.8	3.84	<0.7	9.51	<0.7	2.65
(Microns)	0.8	0.40	0.8	1.16	0.7	1.00	0.7	1.54
u	1.1	0.46	1.1	1.98	1.1	1.69	1.1	2.95
	1.8	1.00	1.8	2.52	1.8	2.88	1.8	2.83
	3.7	1.13	3.7	1.82	3.6	2.00	3.6	2.65
	5.8	1.33	5.8	1.32	5.6	1.38	5.6	1.91
	8.5	1.33	8.5	0.91	8.2	0.81	8.2	0.92
	12.6	0.86	12.6	0.00	12.1	0.69	12.1	0.18
	20.2	0.66	20.2	0.17	19.4	0.63	19.4	0.31
	>20.2	<u>87.63</u>	>20.2	<u>86.29</u>	>19.4	<u>79.42</u>	>19.4	<u>84.06</u>
		99.99		100.01		100.01		100.00



**TABLE 5-19**  
**COMBUSTOR OUTLET PARTICLE SIZE DISTRIBUTION**  
**By Southern Research Institute Five-Stage Cyclone**

DATE AND TIME	2/10/83 1345 to 1515		2/11/83 1007 to 1122		2/11/83 1300 to 1415	
	<u>u</u>	<u>wt %</u>	<u>u</u>	<u>wt %</u>	<u>u</u>	<u>wt %</u>
PARTICLE SIZING						
(Microns)						
u						
	<1.0	17.58	<1.0	8.10	<1.0	10.76
	1.0	4.76	1.0	3.05	1.0	2.29
	1.8	1.29	1.8	0.93	1.8	1.07
	3.9	2.35	3.9	1.25	3.9	1.18
	5.2	7.33	5.2	6.73	5.2	7.59
	>10.0	<u>66.70</u>	>10.0	<u>79.94</u>	>9.9	<u>77.11</u>
		100.01		100.00		100.00

**TABLE 5-20**  
**APITRON OUTLET PARTICLE SIZE DISTRIBUTION**  
**By Andersen In-Stack Sampler**

DATE AND TIME	2/9/83 1019 to 1622		2/10/83 0855 to 2127	
	<u>u</u>	<u>wt %</u>	<u>u</u>	<u>wt %</u>
(Microns)	<0.6	39.13	<0.6	29.03
u	0.6	0.00	0.6	4.84
	0.9	0.00	0.9	4.84
	1.5	5.80	1.5	4.84
	3.0	8.70	3.0	8.06
	4.7	0.00	4.7	8.06
	7.0	8.70	6.9	16.13
	10.3	4.35	10.3	8.06
	16.5	23.19	16.5	4.84
	>16.5	<u>10.14</u>	>16.5	<u>11.29</u>
		100.01		99.99

**TABLE 5-21  
APPROXIMATE CYCLONE AND APITRON  
REMOVAL EFFICIENCY BY PARTICLE SIZE**

Approximate Cut Size	Apitron Inlet (Combustor Outlet)		Apitron Outlet		Overall Cyclone/Apitron
	Micron Size (u)	Average % Wt <sup>(1)</sup>	Average Emission (lb/hr)	Average % Wt <sup>(2)</sup>	Average Emission (lb/hr)
<0.06-0.8	5.3	9.0	34.2	0.94	89.5
0.6.-0.9	1.0	1.7	2.4	0.07	95.9
0.9-1.1	1.8	3.1	2.4	0.07	97.7
1.5-1.8	2.3	3.9	5.3	0.15	96.2
3.0-3.7	1.9	3.2	8.4	0.23	92.8
4.7-5.8	1.5	2.6	4.0	0.11	95.8
7.0-8.5	1.0	1.7	12.4	0.34	80.0
10.3-12.6	0.4	0.7	6.2	0.17	75.7
16.5-20.2	0.4	0.7	14.0	0.38	45.7
>16.5-20.2	<u>84.4</u>	<u>143.4</u>	<u>10.7</u>	<u>0.29</u>	<u>99.8</u>
	100.0	170.0 <sup>(3)</sup>	100.0	2.74 <sup>(3)</sup>	98.4

(1) From Table 5-18

(2) From Table 5-20

(3) From Table 5-16

## F. HEAVY METALS

Heavy metal analyses included sampling for mercury by U.S. EPA Method 101 and sampling other CARB selected heavy metals from the particulate from the multiclone cyclones and filter. Samples were submitted for analysis by atomic absorption. Use of the multiclone resulted in greater amounts of particulate being collected in individual cyclones than would have been possible using the Andersen cascade impactor. The larger samples were needed for atomic absorption in order to give greater sensitivity to the results.

### 1. MERCURY:

Total mercury was sampled at the combustor outlet at three separate times. The average emission factors presented in Table 5-22 are 0.00171 lb/ton and 0.000216 lb/10<sup>6</sup> Btu. The emission factors from Kure were 0.00045 lb/ton and 0.0000805 lb/10<sup>6</sup> Btu.

The solid waste and residue were also sampled for mercury. An average of 0.13 ppm mercury was found in the solid waste and an average of 0.15 ppm was found in the residue. Although it is generally felt that all of the mercury in the waste stream is vaporized, mercury in the residue would appear to indicate that some mercury does remain in the residue, possibly in the unburned waste in the bottom ash if it is not from the fly ash which is placed with the residue in the quench tank.

### 2. OTHER HEAVY METALS:

The weight percentages of the heavy metals analyzed on the particulate from the rotary combustor outlet are presented in Table 5-23. The values for three of the four sampling runs are averaged and compared with the Kure results. Multiclone run #1 was discarded because of an air leak in the sampling probe. However, all the analyses on all the runs may be found on the Appendix, Part 2. The emission factors for the heavy metals based on the average particulate emission rate and the percentages shown in Table 5-23 are presented in Table 5-24.

**TABLE 5-22  
TOTAL MERCURY EMISSIONS AT THE COMBUSTOR OUTLET**

<u>Date and Time</u>	<u>Concentration</u>		<u>Feed Rate</u>		<u>Emission Factors</u>	
	<u>gr/SDCF</u>	<u>lb/hr</u>	<u>TPH</u>	<u>10<sup>6</sup> Btu/hr</u>	<u>lb/ton</u>	<u>lb/10<sup>6</sup> Btu</u>
2/7/83 1050 to 1437	5.9x10 <sup>-5</sup>	0.0046	3.86	35.58	11.9x10 <sup>-4</sup>	12.9x10 <sup>-5</sup>
2/8/83 0855 to 1130	1.36x10 <sup>-4</sup>	0.0107	4.0	30.59	26.8x10 <sup>-4</sup>	35.0x10 <sup>-5</sup>
2/9/83 0940 to 1215	6.48x10 <sup>-5</sup>	0.0048	3.79	28.41	12.7x10 <sup>-4</sup>	16.9x10 <sup>-5</sup>
AVERAGE	8.66x10 <sup>-5</sup>	0.0067			17.1x10 <sup>-4</sup>	21.6x10 <sup>-5</sup>

**TABLE 5-23**  
**HEAVY METAL WEIGHT PERCENTAGES ON**  
**UNABATED PARTICULATE AT COMBUSTOR OUTLET**

<u>Element</u>	<u>Weight % of Total Particulate</u>				
	<u>Kure</u>	<u>Gallatin</u>			<u>Average</u>
		<u>Sample # 2</u>	<u>Sample # 3</u>	<u>Sample # 4</u>	
Arsenic (As)	<0.046	0.0081	0.0077	0.0062	0.0073
Beryllium (Be)	—	<0.00010	<0.00013	<0.00009	<0.00011
Cadmium (Cd)	<0.151	0.080	0.029	0.054	0.054
Chromium (Cr)	0.097	0.023	0.017	0.013	0.018
Selenium (Se)	<0.00697	<0.00013	<0.00042	<0.00043	<0.00033
Nickel (Ni)	0.063	<0.0095	<0.0091	<0.0042	<0.0076
Vanadium (V)	0.011	<0.0028	<0.0037	<0.0029	<0.0031
Zinc (Zn)	7.296	1.55	3.22	0.94	1.90
Lead (Pb)	0.754	0.892	0.495	0.49	0.626
Antimony (Sb)	0.094	0.075	0.015	0.165	0.085
Copper (Cu)	0.090	0.071	0.071	0.089	0.077
Manganese (Mn)	0.181	0.190	0.124	0.100	0.138
Molybdenum (Mo)	0.010	0.0034	0.0034	0.0044	0.0037
Tin (Sn)	0.653	0.096	<0.067	0.050	<0.071

**TABLE 5-24  
UNABATED (COMBUSTOR OUTLET) HEAVY METAL EMISSION RATES**

<u>Element</u>	<u>Average Weight %</u>	<u>Particulate Average lb/hr</u>	<u>Element Emission Rate (lb/hr)</u>	<u>Average Feed Rate</u>		<u>Emission Factors</u>	
				<u>TPH</u>	<u>10<sup>6</sup> Btu/hr</u>	<u>10<sup>-3</sup> lb/ton</u>	<u>10<sup>-4</sup> lb/10<sup>6</sup> Btu</u>
Arsenic (As)	0.0073	163.5	0.0119	3.74	29.01	3.18	4.10
Beryllium (Be)	<0.00011	163.5	<0.000180	3.74	29.01	<0.048	<0.062
Cadmium (Cd)	0.054	163.5	0.0883	3.74	29.01	23.6	30.4
Chromium (Cr)	0.018	163.5	0.0294	3.74	29.01	7.86	10.1
Selenium (Se)	<0.00033	163.5	<0.000540	3.74	29.01	<0.144	<0.186
Nickel (Ni)	<0.00076	163.5	<0.00124	3.74	29.01	<0.332	<0.427
Vanadium (V)	<0.0031	163.5	<0.00507	3.74	29.01	<13.6	<1.75
Zinc (Zn)	1.9	163.5	3.107	3.74	29.01	831	1,071
Lead (Pb)	0.626	163.5	1.024	3.74	29.01	274	353
Antimony (Sb)	0.085	163.5	0.139	3.74	29.01	37.2	47.9
Copper (Cu)	0.077	163.5	0.126	3.74	29.01	33.7	43.4
Manganese (Mn)	0.138	163.5	0.226	3.74	29.01	60.4	77.9
Molybdenum (Mo)	0.0037	163.5	0.00605	3.74	29.01	1.62	209
Tin (Sn)	<0.071	163.5	<0.116	3.74	29.01	<31.0	<40.0

- 79 -

West County Agency of Contra Costa County  
Waste Co-Disposal/Energy Recovery Project

July, 1984

Table 5-25 presents the results for the heavy metal distribution in three weight fractions, less than 1.0u, 1.0 to 3.9u, and greater than 3.9u. These particle size figures are nominal figures which represent the aerodynamic mean cut diameter of the particles. For example, a figure of 1.0u indicates that 50% of the particles are larger than 1.0u and 50% are smaller than 1.0u. As such, the particle size distribution data show relative amounts of particles in each size range, but do not give the actual amount of particulate within the stated size range.

The multiclone fractions from some cyclones had to be combined in some cases to obtain a sufficient sample to analyze. The heavy metal distribution results from Gallatin are compared to the results from Kure. Some heavy metals were below the level of detection; therefore, distribution by particle size was not calculated.



**TABLE 5-25  
HEAVY METAL DISTRIBUTION ON PARTICULATE**

Size Range ( u ): Element	WEIGHT FRACTION														
	Kure	>3.9 u				Kure	1.0 to 3.9 u				Kure	<1.0 u			
		Gallatin					Gallatin					Gallatin			
		# 2	# 3	# 4	Ave.		# 2	# 3	# 4	Ave.		# 2	# 3	# 4	Ave.
Arsenic (As)	—	35.9	95.7	74.2	68.6	—	14.2	1.1	4.8	6.7	—	49.9	3.2	21.0	24.7
Beryllium (Be) <sup>(1)</sup>	—	—	—	—	—	—	—	—	—	—	—	—	—	—	—
Cadmium (Cd)	—	17.8	31.4	22.4	23.9	—	18.2	12.4	13.7	14.8	—	64.0	56.2	63.9	61.4
Chromium (Cr)	81.4	85.1	80.8	87.9	84.6	16.8	7.4	12.1	8.7	9.4	1.8	7.5	7.1	3.4	6.0
Selenium (Se) <sup>(1)</sup>	—	—	—	—	—	—	—	—	—	—	—	—	—	—	—
Nickel (Ni) <sup>(1)</sup>	75.1	—	—	—	—	20.2	—	—	—	—	4.7	—	—	—	—
Vanadium (V) <sup>(1)</sup>	48.8	—	—	—	—	29.4	—	—	—	—	21.8	—	—	—	—
Zinc (Zn)	57.7	31.4	41.2	41.5	38.0	19.0	14.1	21.0	13.9	16.3	23.3	54.5	37.8	44.6	45.6
Lead (Pb)	35.1	20.8	38.0	30.1	29.6	25.5	16.3	11.2	13.0	13.5	39.4	63.0	50.8	56.9	56.9
Antimony (Sb)	—	8.2	3.0	11.9	7.7	—	5.3	18.1	9.8	11.1	—	86.5	78.9	78.3	81.2
Copper (Cu)	48.7	50.3	74.1	64.8	63.1	23.8	10.2	5.6	6.1	17.3	27.5	39.4	20.3	29.1	29.6
Manganese (Mn)	94.8	95.7	97.6	94.7	96.0	4.4	2.0	1.5	2.1	1.9	0.8	2.3	0.8	3.2	2.1
Molybdenum (Mo)	49.4	63.8	79.3	56.5	66.5	26.1	19.3	8.1	6.1	11.2	24.5	16.9	12.6	37.4	22.3
Tin (Sn)	32.5	9.2	5.1	16.0	10.1	28.9	21.4	26.8	16.9	21.7	38.6	69.4	68.1	67.1	68.2

(1) Gallatin levels of concentrations were below the level of detection.

## G. CONTINUOUS EMISSIONS MONITORING (CEM) DATA

### 1. CEM DATA RECORDED AND SUMMARIZED:

The continuous emission monitors analyzed and recorded the dry concentration of O<sub>2</sub>, CO, CO<sub>2</sub>, NO<sub>x</sub>, SO<sub>2</sub> and the in-duct (wet) concentration of NMHC. A continuous readout of the data and five-minute compilations of that data, except hydrocarbons, are available in the Appendix, Part 2. Table 5-8, which presents the hours that the rotary combustor operated, also presents the hours that the CEM, except the hydrocarbon monitor, were operational. The monitors, as a network, experienced problems such as frozen sample lines and leaks. To better analyze the CEM data, the hours that the data were recorded but thought to be usable and not usable were listed in Table 5-8. Also, the hours when the plant was upset, starting up, shutting down, or experiencing an unusual fuel were listed so that the CEM data recorded during those hours could be compared with other more "normal" hours of operation.

The CEM data for O<sub>2</sub>, CO, NO<sub>x</sub>, and SO<sub>2</sub> from the individual strip charts were interpolated into five minute readings. The in-duct dry concentrations were adjusted to 7% O<sub>2</sub>, dry basis, which represents approximately 50% excess air, to use as a standard of comparison for the WCA waste-to-energy project's combustion system. The adjusted five minute readings were averaged for each hour. The results of the hourly averages for CO, NO<sub>x</sub>, and SO<sub>2</sub> for the first week, 2/7/83 to 2/14/83, and the second week, 2/14/83 to 2/21/83, were compared with the operating hours shown in Table 5-8 to produce two sets of tables. The CEM data are presented as that CEM data from "typical plant operation" which excludes data taken during startup, shutdown, upset conditions, unusual fuel conditions, and unusable CEM operation and all CEM data which excludes only the unusable CEM data. Tables 5-26 and 5-27 present the hourly CO, NO<sub>x</sub> and SO<sub>2</sub> averages calculated for "typical plant operation" for the first and second weeks, respectively. Tables 5-28 and 5-29 present the hourly CO, NO<sub>x</sub> and SO<sub>2</sub> averages including data taken during upset, startup, shutdown, and unusual fuel conditions for the first and second weeks, respectively.

TABLE 5-26  
CEM DATA  
FIRST WEEK, HOURLY, TYPICAL CONDITIONS

Data Corrected to 7% Oxygen, ppm<sub>dv</sub>

	MONDAY 7th			TUESDAY 8th			WEDNESDAY 9th			THURSDAY 10th			FRIDAY 11th			SATURDAY 12th			SUNDAY 13th			MONDAY 14th								
	CO	NO <sub>x</sub>	SO <sub>2</sub>	CO	NO <sub>x</sub>	SO <sub>2</sub>	CO	NO <sub>x</sub>	SO <sub>2</sub>	CO	NO <sub>x</sub>	SO <sub>2</sub>	CO	NO <sub>x</sub>	SO <sub>2</sub>	CO	NO <sub>x</sub>	SO <sub>2</sub>	CO	NO <sub>x</sub>	SO <sub>2</sub>	CO	NO <sub>x</sub>	SO <sub>2</sub>						
0000							350	131	108	554	143	X	328	161	145	241	90	N	310	181	279									
0100							669	129	94	853	127	X	502	142	211	397	76	N	247	131	210									
0200							802	139	144	775	125	X	X	X	X	981	99	N	526	117	166									
0300				ANALYZER DOWN			945	146	103	821	117	X	918	142	132	260	109	N	138	123	155									
0400							1080	120	128	657	114	X	854	118	346	88	116	N	219	146	111									
0500							535	115	126	383	136	X	1417	126	528	193	105	N	172	152	263									
0600							295	141	120	521	117	X	854	144	487	90	129	N	255	146	293									
0700							803	145	99	610	145	X	605	136	116	152	108	N	443	137	194				COMBUSTOR DOWN					
0800				START OF TESTING			X	X	X	484	169	135	814	X	240	608	127	271	690	97	N	568	110	256				END FIRST WEEK		
0900	X	X	X	2055	211	216	362	165	145	811	X	78	261	139	241	334	112	N	262	161	410									
1000	X	X	X	851	157	107	707	133	261	510	X	39	308	138	215	179	152	N	189	174	453									
1100	X	X	X	611	201	95	641	132	99	494	159	96	390	133	129	249	134	N	160	165	258									
1200	268	193	30	290	175	100	513	161	71	313	157	95	533	135	271	293	133	N	262	157	329									
1300	226	194	25	205	160	146	316	148	64	415	164	78	376	158	115	327	136	N	175	158	283									
1400	262	182	28	146	163	104	775	131	162	799	127	70	485	157	87	224	169	N	381	158	236									
1500	209	203	33	171	181	107	290	162	105	1182	143	67	1139	119	255	508	131	N	COMBUSTOR DOWN											
1600	152	182	45	197	171	129	453	177	172	844	132	144	813	117	338	483	127	N												
1700	111	158	40	239	175	116	431	138	651	588	152	233	330	126	247	294	130	N												
1800	519	153	139	314	187	156	X	X	X	181	158	115	528	121	187	288	140	N												
1900	159	161	137	160	150	159	1193	156	184	270	147	112	633	109	153	156	123	N												
2000	183	144	88	385	133	196	578	181	345	175	149	161	940	110	285	143	135	N												
2100	214	163	138	510	158	151	1112	185	X	ANALYZER DOWN			724	101	121	469	95	N												
2200	290	122	106	491	150	172	382	135	X				777	93	209	292	128	N												
2300	X	X	X	1831	185	144	571	132	X				1044	95	144	297	151	N												
24 HR Avg.	235	169	74	564	169	141	622	147	166	598	140	117	668	128	228	318	122		287	148	260	--	--	--						

N = CEM data not processed.  
X = Represents CEM data recorded but unusable or CEM data taken during upset, shutdown, or unusual fuel conditions.

TABLE 5-27  
CEM DATA  
SECOND WEEK, HOURLY, TYPICAL CONDITIONS

Data Corrected to 7% Oxygen, ppm<sub>v</sub>

	MONDAY 14th			TUESDAY 15th			WEDNESDAY 16th			THURSDAY 17th			FRIDAY 18th			SATURDAY 19th			SUNDAY 20th			MONDAY 21st		
	CO	NO <sub>x</sub>	SO <sub>2</sub>	CO	NO <sub>x</sub>	SO <sub>2</sub>	CO	NO <sub>x</sub>	SO <sub>2</sub>	CO	NO <sub>x</sub>	SO <sub>2</sub>	CO	NO <sub>x</sub>	SO <sub>2</sub>	CO	NO <sub>x</sub>	SO <sub>2</sub>	CO	NO <sub>x</sub>	SO <sub>2</sub>	CO	NO <sub>x</sub>	SO <sub>2</sub>
0000	UNIT DOWN			1058	170	N	760	144	125				X	X	N	UNIT DOWN			X	X	N	X	X	N
0100				502	124	N	516	129	134				X	X	N	X	X	N	X	X	N	X	X	N
0200				862	148	N	501	143	220				X	X	N	X	X	N	X	X	N	X	X	N
0300				722	134	N	356	131	164				X	X	N	X	X	N	X	X	N	X	X	N
0400				349	148	N	1419	132	265				X	X	N	X	X	N	X	X	N	X	X	N
0500				400	119	N	1119	149	162				X	X	N	X	X	N	X	X	N	X	X	N
0600				721	135	N	X	X	X				X	X	N	X	X	N	X	X	N	X	X	N
0700				876	132	N	X	X	X				X	X	N	X	X	N	X	X	N	<u>END OF TEST</u>		
0800				1451	185	N	X	X	X				X	X	N	X	X	N	X	X	N			
0900	X	X	N	478	181	N	X	X	X				X	X	N	X	X	N	X	X	N			
1000	X	X	N	1195	241	N	X	X	X				X	X	N	X	X	N	X	X	N			
1100	X	X	N	584	194	N	UNIT DOWN						X	X	N	X	X	N	X	X	N			
1200	957	200	N	1198	219	N							X	X	N	X	X	N	X	X	N			
1300	426	212	N	454	161	N							X	X	N	X	X	N	X	X	N			
1400	954	174	N	750	147	N							X	X	N	X	X	N	X	X	N			
1500	1176	190	N	792	156	N							X	X	N	X	X	N	X	X	N			
1600	374	189	N	656	118	N							UNIT DOWN			X	X	N	X	X	N			
1700	278	189	N	578	122	N							X	X	N	X	X	N	X	X	N			
1800	276	204	N	879	119	N							DATA NOT TAKEN			X	X	N	X	X	N			
1900	262	159	N	828	106	N							X	X	N	X	X	N	X	X	N			
2000	422	207	N	337	142	N							X	X	N	X	X	N	X	X	N			
2100	265	200	N	1037	158	N							X	X	N	X	X	N	X	X	N			
2200	227	182	N	923	125	N							X	X	N	X	X	N	X	X	N			
2300	305	184	N	570	141	N							X	X	N	X	X	N	X	X	N			
24 HR Avg.	494	191	--	758	151		779	138	178															

N = CEM data not processed.  
X = Represents CEM data recorded but unusable or CEM data taken during upset, shutdown, or unusual fuel conditions.

**TABLE 5-28  
CEM DATA  
FIRST WEEK, HOURLY, INCLUDING UNUSUAL CONDITIONS<sup>(1)</sup>**

Data Corrected to 7% Oxygen, ppm <sub>dv</sub>																								
MONDAY 7th			TUESDAY 8th			WEDNESDAY 9th			THURSDAY 10th			FRIDAY 11th			SATURDAY 12th			SUNDAY 13th			MONDAY 14th			
CO	NO <sub>x</sub>	SO <sub>2</sub>	CO	NO <sub>x</sub>	SO <sub>2</sub>	CO	NO <sub>x</sub>	SO <sub>2</sub>	CO	NO <sub>x</sub>	SO <sub>2</sub>	CO	NO <sub>x</sub>	SO <sub>2</sub>	CO	NO <sub>x</sub>	SO <sub>2</sub>	CO	NO <sub>x</sub>	SO <sub>2</sub>	CO	NO <sub>x</sub>	SO <sub>2</sub>	
0000						350	131	108	554	143	386	328	161	145	241	90	N	310	181	279				
0100						669	129	94	853	127	343	502	142	211	397	76	N	247	131	210				
0200						802	139	144	775	125	283	2490	194	159	981	99	N	526	117	166				
0300						945	146	103	821	117	296	918	142	132	260	109	N	138	123	155				
0400						1080	120	128	657	114	227	854	118	346	88	116	N	219	146	111			COMBUSTOR DOWN	
0500						535	115	126	383	136	185	1417	126	528	193	105	N	172	152	263				
0600						295	141	120	521	117	192	854	144	487	90	129	N	255	146	293				
0700						803	145	99	610	145	159	605	136	116	152	108	N	443	137	194				
0800	START OF TESTING			X	X	X	484	169	135	814	X	240	608	127	271	690	97	N	568	110	256			
0900	X	231	151	2055	211	216	362	165	145	811	X	78	261	139	241	334	112	N	262	161	410			END OF FIRST WEEK
1000	X	164	127	851	157	107	707	133	261	510	X	39	308	138	215	179	152	N	189	174	453			
1100	828	240	78	611	201	95	641	132	99	494	159	96	390	133	129	249	134	N	160	165	258			
1200	268	193	30	290	175	100	513	161	71	313	157	95	533	135	271	293	133	N	262	157	329			
1300	226	194	25	205	160	146	316	148	64	415	164	78	376	158	115	327	136	N	175	158	283			
1400	262	182	28	146	163	104	775	131	162	799	127	70	485	157	87	224	169	N	381	158	236			
1500	209	203	33	171	181	107	290	162	105	1182	143	67	1139	119	255	508	131	N	COMBUSTOR DOWN					
1600	152	182	45	197	171	129	453	177	172	844	132	144	813	117	338	483	127	N						
1700	111	158	40	239	175	116	431	138	651	588	152	233	330	126	247	294	130	N						
1800	519	153	139	314	187	156	X	X	X	181	158	115	528	121	187	288	140	N						
1900	159	161	137	160	150	159	1193	156	184	270	147	112	633	109	153	156	123	N						
2000	183	144	88	385	133	196	578	181	345	175	149	161	940	110	285	143	135	N						
2100	214	163	138	510	158	151	1112	185	1328				724	101	121	469	95	N						
2200	290	122	106	491	150	172	382	135	809				777	93	209	292	128	N						
2300	196	117	45	1831	185	144	571	132	671				1044	95	144	297	151	N						
24 HR Avg.	278	174	81	564	169	141	622	147	266	598	140	171	744	131	225	318	122		287	148	260			

N = CEM data not processed.

X = Represents CEM data recorded but unusable.

(1) Unusual conditions include plant upset, unusual fuel, startup, and shutdown.

TABLE 5-29  
CEM DATA  
SECOND WEEK, HOURLY, INCLUDING UNUSUAL CONDITIONS<sup>(1)</sup>

Data Corrected to 7% Oxygen, ppm<sub>dv</sub>

	MONDAY 14th			TUESDAY 15th			WEDNESDAY 16th			THURSDAY 17th			FRIDAY 18th			SATURDAY 19th			SUNDAY 20th			MONDAY 21st		
	CO	NO <sub>x</sub>	SO <sub>2</sub>	CO	NO <sub>x</sub>	SO <sub>2</sub>	CO	NO <sub>x</sub>	SO <sub>2</sub>	CO	NO <sub>x</sub>	SO <sub>2</sub>	CO	NO <sub>x</sub>	SO <sub>2</sub>	CO	NO <sub>x</sub>	SO <sub>2</sub>	CO	NO <sub>x</sub>	SO <sub>2</sub>	CO	NO <sub>x</sub>	SO <sub>2</sub>
0000	UNIT DOWN			1058	170	N	760	144	125	UNIT DOWN			2065	157	N	UNIT DOWN						1966	111	N
0100				502	124	N	516	129	134				1337	134	N							1821	126	N
0200				862	148	N	501	143	220				943	136	N							1979	122	N
0300				722	134	N	356	131	164				525	150	N							1188	98	N
0400				349	148	N	1419	132	265				772	135	N							1088	97	N
0500				400	119	N	1119	149	162				1897	104	N							1207	150	N
0600				721	135	N	5620	194	374				877	144	N							751	104	N
0700				876	132	N	1863	194	309				992	115	N							1257	119	N
0800				1451	185	N	1580	120	236				507	115	N							END OF TEST		
0900				478	181	N	10654	82	220				913	153	N									
1000	X	X	N	1195	241	N	8334	73	406				867	147	N				X	X	N			
1100	X	X	N	584	194	N	UNIT DOWN						681	155	N				X	X	N			
1200	957	200	N	1198	219	N							631	147	N				X	X	N			
1300	426	212	N	454	161	N							3732	86	N				X	X	N			
1400	954	174	N	750	147	N							11100	184	N				1689	81	N			
1500	1176	190	N	792	156	N							2855	82	N				2298	77	N			
1600	374	189	N	656	118	N							UNIT DOWN						3537	100	N			
1700	278	189	N	578	122	N												8206	136	N				
1800	276	204	N	879	119	N												3671	120	N				
1900	262	159	N	828	106	N												928	119	N				
2000	422	207	N	337	142	N												1078	130	N				
2100	265	200	N	1037	158	N												924	112	N				
2200	227	182	N	923	125	N												1059	99	N				
2300	305	184	N	570	141	N												1621	111	N				
24 HR Avg.	494	191		758	151		2974	136	238				1918	134				2501	108			1407	116	

N = CEM data not processed.

X = Represents CEM data recorded but unusable.

(1) Unusual conditions include plant upset, unusual fuel, startup, and shutdown.

The data from the hourly summaries shown in the preceding four tables including the hydrocarbon data, are summarized in daily summaries using a similar format, i.e., weeks one and two and typical and upset conditions. Tables 5-30 through 5-33 present the daily summaries for each week and for each operating condition. The daily summaries show the number of hours of CEM data recorded that day, the daily average concentration and the maximum 1-hour, 2-hour and 3-hour readings. The maximum hourly readings can be used for ambient air quality impact analyses (AAQIAs).

Table 5-34 presents a summary of the daily CEM readings for the first and second weeks, including the NMHC reading which are discussed in greater detail in Subsection 5.I.

**TABLE 5-30  
CEM DATA  
FIRST WEEK, DAILY, TYPICAL CONDITIONS**

	Monday, February 7, 1983						Tuesday, February 8, 1983						
	O <sub>2</sub>	CO	NO <sub>x</sub> Corrected to 7% O <sub>2</sub> (dry)	SO <sub>2</sub>	HC	O <sub>2</sub> <sup>(1)</sup>	O <sub>2</sub>	CO	NO <sub>x</sub> Corrected to 7% O <sub>2</sub> (dry)	SO <sub>2</sub>	HC	O <sub>2</sub>	
	(dry) %	ppm <sub>dv</sub>	ppm <sub>dv</sub>	ppm <sub>dv</sub>	(wet) ppm <sub>wv</sub>	(wet) %	(dry) %	ppm <sub>dv</sub>	ppm <sub>dv</sub>	ppm <sub>dv</sub>	(wet) ppm <sub>wv</sub>	(wet) %	
Daily Average	9.5	235	169	74	9.9	6.6	8.6	564	169	141	32.2	6.5	
1-Hour Maximum		519	203	139	12.8			2055	211	216	155.3		
2-Hour Maximum		339	194	138	—			1853	188	177	—		
3-Hour Maximum		287	193	121	—			1172	190	170	—		
Hours of Recorded Data		11	11	11	3			15	15	15	7		
		Wednesday, February 9, 1983						Thursday, February 10, 1983					
	O <sub>2</sub>	CO	NO <sub>x</sub> Corrected to 7% O <sub>2</sub> (dry)	SO <sub>2</sub>	HC	O <sub>2</sub> <sup>(1)</sup>	O <sub>2</sub>	CO	NO <sub>x</sub> Corrected to 7% O <sub>2</sub> (dry)	SO <sub>2</sub>	HC	O <sub>2</sub>	
	(dry) %	ppm <sub>dv</sub>	ppm <sub>dv</sub>	ppm <sub>dv</sub>	(wet) ppm <sub>wv</sub>	(wet) %	(dry) %	ppm <sub>dv</sub>	ppm <sub>dv</sub>	ppm <sub>dv</sub>	(wet) ppm <sub>wv</sub>	(wet) %	
Daily Average	9.8	622	147	166	40.1	6.2	11.2	598	140	171	22.4	5.5	
1-Hour Maximum		1193	185	651	99.7			1182	164	240	42.5		
2-Hour Maximum		1017	183	411	—			1013	160	189	—		
3-Hour Maximum		961	174	309	—			942	160	164	—		
Hours of Recorded Data		23	23	20	4			21	18	13	4		

(1) In-situ O<sub>2</sub> (wet) analyzer after boiler convection section and before the GAH.



TABLE 5-30 (continued)  
CEM DATA  
FIRST WEEK, DAILY, TYPICAL CONDITIONS

	Friday, February 11, 1983					Saturday, February 12, 1983						
	O <sub>2</sub>	CO	NO <sub>x</sub>	SO <sub>2</sub>	HC	O <sub>2</sub>	CO	NO <sub>x</sub>	SO <sub>2</sub>	HC		
	(dry) %	ppm <sub>dv</sub>	Corrected to 7% O <sub>2</sub> (dry) ppm <sub>dv</sub>	ppm <sub>dv</sub>	(wet) ppm <sub>wv</sub>	(dry) %	ppm <sub>dv</sub>	Corrected to 7% O <sub>2</sub> (dry) ppm <sub>dv</sub>	ppm <sub>dv</sub>	(wet) ppm <sub>wv</sub>		
Daily Average	8.2	668	128	228	6.7	5.3	7.8	318	122	—	—	5.3
1-Hour Maximum		1417	161	528	7.9			981	169	—	—	
2-Hour Maximum		1136	158	508	—			689	152	—	—	
3-Hour Maximum		1042	150	454				546	146	—	—	
Hours of Recorded Data		23	23	23	7			24	24	—	—	
		Sunday, February 13, 1983					Monday, February 14, 1983					
	O <sub>2</sub>	CO	NO <sub>x</sub>	SO <sub>2</sub>	HC	O <sub>2</sub>	O <sub>2</sub>	CO	NO <sub>x</sub>	SO <sub>2</sub>	HC	O <sub>2</sub>
	(dry)		Corrected to		(wet)	(wet)	(dry)		Corrected to		(wet)	(wet)
	%	ppm <sub>dv</sub>	7% O <sub>2</sub> (dry) ppm <sub>dv</sub>	ppm <sub>dv</sub>	ppm <sub>wv</sub>	%	%	ppm <sub>dv</sub>	7% O <sub>2</sub> (dry) ppm <sub>dv</sub>	ppm <sub>dv</sub>	ppm <sub>wv</sub>	%
Daily Average	8.3	287	148	260	—	5.7						
1-Hour Maximum		568	181	453	—							
2-Hour Maximum		506	169	432	—							
3-Hour Maximum		424	167	374	—							
Hours of Recorded Data		15	15	15	—							

PLANT UPSET  
0000 TO 0800

**TABLE 5-30 (continued)**  
**CEM DATA**  
**FIRST WEEK, DAILY, TYPICAL CONDITIONS**

**WEEKLY TOTALS**

	O <sub>2</sub> (dry) %	CO ppm <sub>dv</sub>	NO <sub>x</sub> Corrected to 7% O <sub>2</sub> (dry) ppm <sub>dv</sub>	SO <sub>2</sub> ppm <sub>dv</sub>	HC (wet) ppm <sub>wv</sub>	O <sub>2</sub> (wet) %
Monday	9.5	235	169	74	9.9	6.6
Tuesday	8.6	564	169	141	32.2	6.5
Wednesday	9.8	622	147	166	40.1	6.2
Thursday	11.2	598	140	117	22.4	5.5
Friday	8.2	668	128	228	6.7	5.3
Saturday	7.8	318	122	—	—	5.3
Sunday	8.3	287	148	260	—	5.7
Monday	—	—	—	—	—	—
<b>Weighted Weekly Average</b>	9.1	494	143	182	22.1	5.9
<b># Hours of Recorded Data</b>		132	129	97	25	
		ppm <sub>dv</sub>	ppm <sub>dv</sub>	ppm <sub>dv</sub>	ppm <sub>wv</sub>	
<b>Worst:</b>						
1-Hour		2055	211	651	155.3	
2-Hour		1853	194	508	—	
3-Hour		1172	193	454	—	
Daily Average		668	169	260	40.1	

=====

**TABLE 5-31  
CEM DATA  
SECOND WEEK, DAILY, TYPICAL CONDITIONS**

	Monday, February 14, 1983					Tuesday, February 15, 1983						
	O <sub>2</sub> (dry) %	CO ppm <sub>dv</sub>	NO <sub>x</sub> Corrected to 7% O <sub>2</sub> (dry) ppm <sub>dv</sub>	SO <sub>2</sub> ppm <sub>dv</sub>	HC (wet) ppm <sub>wv</sub>	O <sub>2</sub> (dry) %	O <sub>2</sub> (dry) %	CO ppm <sub>dv</sub>	NO <sub>x</sub> Corrected to 7% O <sub>2</sub> (dry) ppm <sub>dv</sub>	SO <sub>2</sub> ppm <sub>dv</sub>	HC (wet) ppm <sub>wv</sub>	O <sub>2</sub> (wet) %
Daily Average	11.3	494	191	—	—	7.2	8.3	758	151	—	—	6.0
1-Hour Maximum		1176	212	—	—			1451	241	—	—	
2-Hour Maximum		1065	206	—	—			980	218	—	—	
3-Hour Maximum		852	196	—	—			1041	218	—	—	
Hours of Recorded Data		12	12	—	—			24	24	—	—	
		Wednesday, February 16, 1983				Thursday, February 17, 1983						
	O <sub>2</sub> (dry) %	CO ppm <sub>dv</sub>	NO <sub>x</sub> Corrected to 7% O <sub>2</sub> (dry) ppm <sub>dv</sub>	SO <sub>2</sub> ppm <sub>dv</sub>	HC (wet) ppm <sub>wv</sub>	O <sub>2</sub> (wet) %	O <sub>2</sub> (dry) %	CO ppm <sub>dv</sub>	NO <sub>x</sub> Corrected to 7% O <sub>2</sub> (dry) ppm <sub>dv</sub>	SO <sub>2</sub> ppm <sub>dv</sub>	HC (wet) ppm <sub>wv</sub>	O <sub>2</sub> (wet) %
Daily Average	11.7	779	138	178	—	4.7						
1-Hour Maximum		1419	149	265	—							
2-Hour Maximum		1269	141	215	—							
3-Hour Maximum		965	139	216	—							
Hours of Recorded Data		6	6	6	—							

UNIT DOWN

**TABLE 5-31 (continued)  
CEM DATA  
SECOND WEEK, DAILY, TYPICAL CONDITIONS**

	Friday, February 18, 1983					Saturday, February 19, 1983					
	O <sub>2</sub> (dry) %	CO ppm <sub>dv</sub>	NO <sub>x</sub> Corrected to 7% O <sub>2</sub> (dry) ppm <sub>dv</sub>	SO <sub>2</sub> ppm <sub>dv</sub>	HC (wet) ppm <sub>wv</sub>	O <sub>2</sub> (dry) %	CO ppm <sub>dv</sub>	NO <sub>x</sub> Corrected to 7% O <sub>2</sub> (dry) ppm <sub>dv</sub>	SO <sub>2</sub> ppm <sub>dv</sub>	HC (wet) ppm <sub>wv</sub>	O <sub>2</sub> (wet) %
Daily Average	12.8	--	--	--	--	5.9	UNIT DOWN				
1-Hour Maximum	--	--	--	--	--	--	--	--	--	--	
2-Hour Maximum	--	--	--	--	--	--	--	--	--	--	
3-Hour Maximum	--	--	--	--	--	--	--	--	--	--	
Hours of Recorded Data	DATA UNUSABLE PLANT UPSET										
	Sunday, February 20, 1983					Monday, February 21, 1983					
	O <sub>2</sub> (dry) %	CO ppm <sub>dv</sub>	NO <sub>x</sub> Corrected to 7% O <sub>2</sub> (dry) ppm <sub>dv</sub>	SO <sub>2</sub> ppm <sub>dv</sub>	HC (wet) ppm <sub>wv</sub>	O <sub>2</sub> (dry) %	CO ppm <sub>dv</sub>	NO <sub>x</sub> Corrected to 7% O <sub>2</sub> (dry) ppm <sub>dv</sub>	SO <sub>2</sub> ppm <sub>dv</sub>	HC (wet) ppm <sub>wv</sub>	O <sub>2</sub> (wet) %
Daily Average	13.9	--	--	--	--	5.3	11.7	--	--	--	--
1-Hour Maximum	--	--	--	--	--	--	--	--	--	--	
2-Hour Maximum	--	--	--	--	--	--	--	--	--	--	
3-Hour Maximum	--	--	--	--	--	--	--	--	--	--	
Hours of Recorded Data	DATA UNUSABLE PLANT UPSET					DATA UNUSABLE PLANT UPSET					

**TABLE 5-31 (continued)**  
**CEM DATA**  
**SECOND WEEK, DAILY, TYPICAL CONDITIONS**

**WEEKLY TOTALS**

	O <sub>2</sub> (dry) %	CO ppm <sub>dv</sub>	NO <sub>x</sub> Corrected to 7% O <sub>2</sub> ppm <sub>dv</sub>	SO <sub>2</sub> (dry) ppm <sub>dv</sub>	HC (wet) ppm <sub>wv</sub>	O <sub>2</sub> (wet) %
Monday	11.3	494	191	—	—	7.2
Tuesday	8.3	758	151	—	—	6.0
Wednesday	11.7	779	138	178	—	4.7
Thursday	—	—	—	—	—	—
Friday	12.8	—	—	—	—	5.9
Saturday	—	—	—	—	—	—
Sunday	13.9	—	—	—	—	5.3
Monday	11.7	—	—	—	—	—
<b>Weighted Weekly Average</b>	11.6	686	160	178		5.8
<b># Hours of Recorded Data</b>		42	42	6		
		ppm <sub>dv</sub>	ppm <sub>dv</sub>	ppm <sub>dv</sub>	ppm <sub>wv</sub>	
<b>Worst:</b>						
1-Hour		1451	241	265		
2-Hour		1269	218	215		
3-Hour		1041	218	216		
Daily Average		779	191	178		

**TABLE 5-32  
CEM DATA  
FIRST WEEK, DAILY, INCLUDING UNUSUAL CONDITIONS<sup>(1)</sup>**

	Monday, February 7, 1983					Tuesday, February 8, 1983						
	O <sub>2</sub>	CO	NO <sub>x</sub> Corrected to 7% O <sub>2</sub> (dry)	SO <sub>2</sub>	HC	O <sub>2</sub>	CO	NO <sub>x</sub> Corrected to 7% O <sub>2</sub> (dry)	SO <sub>2</sub>	HC	O <sub>2</sub>	
	%	ppm <sub>dv</sub>	ppm <sub>dv</sub>	ppm <sub>dv</sub>	(wet) ppm <sub>wv</sub>	(wet) %	%	ppm <sub>dv</sub>	ppm <sub>dv</sub>	ppm <sub>dv</sub>	(wet) ppm <sub>wv</sub>	(wet) %
Daily Average	9.5	278	174	81	9.9	6.6	8.6	564	169	141	32.2	6.5
1-Hour Maximum		828	240	151	12.8			2055	211	216	155.3	
2-Hour Maximum		548	216	139	—			1853	188	177	—	
3-Hour Maximum		441	209	121	—			1172	190	170	—	
Hours of Recorded Data		13	15	15	3			15	15	15	7	
	Wednesday, February 9, 1983					Thursday, February 10, 1983						
	O <sub>2</sub>	CO	NO <sub>x</sub> Corrected to 7% O <sub>2</sub> (dry)	SO <sub>2</sub>	HC	O <sub>2</sub>	CO	NO <sub>x</sub> Corrected to 7% O <sub>2</sub> (dry)	SO <sub>2</sub>	HC	O <sub>2</sub>	
	(dry) %	ppm <sub>dv</sub>	ppm <sub>dv</sub>	ppm <sub>dv</sub>	(wet) ppm <sub>wv</sub>	(wet) %	(dry) %	ppm <sub>dv</sub>	ppm <sub>dv</sub>	ppm <sub>dv</sub>	(wet) ppm <sub>wv</sub>	(wet) %
Daily Average	9.8	622	147	266	40.1	6.2	11.2	598	140	171	22.4	5.5
1-Hour Maximum		1193	185	1328	99.7			1182	164	386	42.5	
2-Hour Maximum		1017	183	1068	—			1013	160	364	—	
3-Hour Maximum		961	174	936	—			942	160	337	—	
Hours of Recorded Data		23	23	23	4			21	18	21	4	

(1) Unusual conditions include plant upset, unusual fuel, startup, and shutdown.

TABLE 5-32 (continued)  
CEM DATA  
FIRST WEEK, DAILY, INCLUDING UNUSUAL CONDITONS<sup>(1)</sup>

	Friday, February 11, 1983					Saturday, February 12, 1983						
	O <sub>2</sub> (dry) %	CO ppm <sub>dv</sub>	NO <sub>x</sub> Corrected to 7% O <sub>2</sub> (dry) ppm <sub>dv</sub>	SO <sub>2</sub> ppm <sub>dv</sub>	HC (wet) ppm <sub>wv</sub>	O <sub>2</sub> (dry) %	O <sub>2</sub> (dry) %	CO ppm <sub>dv</sub>	NO <sub>x</sub> Corrected to 7% O <sub>2</sub> (dry) ppm <sub>dv</sub>	SO <sub>2</sub> ppm <sub>dv</sub>	HC (wet) ppm <sub>wv</sub>	O <sub>2</sub> (wet) %
Daily Average	8.2	744	131	225	6.7	5.3	7.8	318	122	—	—	5.3
1-Hour Maximum		2490	194	528	7.9		981	169	—	—		
2-Hour Maximum		1704	168	508	—		689	152	—	—		
3-Hour Maximum		1421	159	454	—		546	146	—	—		
Hours of Recorded Data		24	24	24	7		24	24	—	—		
	Sunday, February 13, 1983					Monday, February 14, 1983						
	O <sub>2</sub> (dry) %	CO ppm <sub>dv</sub>	NO <sub>x</sub> Corrected to 7% O <sub>2</sub> (dry) ppm <sub>dv</sub>	SO <sub>2</sub> ppm <sub>dv</sub>	HC (wet) ppm <sub>wv</sub>	O <sub>2</sub> (wet) %	O <sub>2</sub> (dry) %	CO ppm <sub>dv</sub>	NO <sub>x</sub> Corrected to 7% O <sub>2</sub> (dry) ppm <sub>dv</sub>	SO <sub>2</sub> ppm <sub>dv</sub>	HC (wet) ppm <sub>wv</sub>	O <sub>2</sub> (wet) %
Daily Average	8.3	287	148	260	—	5.7						
1-Hour Maximum		568	181	453	—							
2-Hour Maximum		506	169	432	—							
3-Hour Maximum		424	167	374	—							
Hours of Recorded Data		15	15	15	—							

(1) Unusual conditions include plant upset, unusual fuel, startup, and shutdown.

**TABLE 5-32 (continued)**  
**CEM DATA**  
**FIRST WEEK, DAILY, INCLUDING UNUSUAL CONDITIONS<sup>(1)</sup>**

	WEEKLY TOTALS					
	O <sub>2</sub> (dry) %	CO ppm <sub>dv</sub>	NO <sub>x</sub> Corrected to 7% O <sub>2</sub> ppm <sub>dv</sub>	SO <sub>2</sub> (dry) ppm <sub>dv</sub>	HC (wet) ppm <sub>wv</sub>	O <sub>2</sub> (wet) %
Monday	9.5	278	174	81	9.9	6.6
Tuesday	8.6	564	169	141	32.2	6.5
Wednesday	9.8	622	147	266	40.1	6.2
Thursday	11.2	598	140	171	22.4	5.5
Friday	8.2	744	131	225	6.7	5.3
Saturday	7.8	318	122	—	—	5.3
Sunday	8.3	287	148	260	—	5.7
Monday		<b>UNIT DOWN A.M.</b>				
Weighted Weekly Average	9.1	509	147	191	22.1	5.9
# Hours of Recorded Data		135	134	113	25	
		<u>ppm<sub>dv</sub></u>	<u>ppm<sub>dv</sub></u>	<u>ppm<sub>dv</sub></u>	<u>ppm<sub>wv</sub></u>	
Worst:						
1-Hour		2490	240	1328	155.3	
2-Hour		1853	216	1068	—	
3-Hour		1421	209	936	—	
Daily Average		744	174	266	40.1	

(1) Unusual conditions include plant upset, unusual fuel, startup, and shutdown.



**TABLE 5-33  
CEM DATA  
SECOND WEEK, DAILY, INCLUDING UNUSUAL CONDITIONS(1)**

Monday, February 14, 1983						Tuesday, February 15, 1983						
	O <sub>2</sub> (dry) %	CO ppm <sub>dv</sub>	NO <sub>x</sub> Corrected to 7% O <sub>2</sub> (dry) ppm <sub>dv</sub>	SO <sub>2</sub> ppm <sub>dv</sub>	HC (wet) ppm <sub>wv</sub>	O <sub>2</sub> (dry) %	O <sub>2</sub> (dry) %	CO ppm <sub>dv</sub>	NO <sub>x</sub> Corrected to 7% O <sub>2</sub> (dry) ppm <sub>dv</sub>	SO <sub>2</sub> ppm <sub>dv</sub>	HC (wet) ppm <sub>wv</sub>	O <sub>2</sub> (wet) %
Daily Average	11.3	494	191	—	—	7.2	8.3	758	151	—	—	6.0
1-Hour Maximum		1176	212	—	—			1451	241	—	—	
2-Hour Maximum		1065	206	—	—			1164	218	—	—	
3-Hour Maximum		852	196	—	—			1016	218	—	—	
Hours of Recorded Data		12	12	—	—			24	24	—	—	
Wednesday, February 16, 1983						Thursday, February 17, 1983						
	O <sub>2</sub> (dry) %	CO ppm <sub>dv</sub>	NO <sub>x</sub> Corrected to 7% O <sub>2</sub> (dry) ppm <sub>dv</sub>	SO <sub>2</sub> ppm <sub>dv</sub>	HC (wet) ppm <sub>wv</sub>	O <sub>2</sub> (wet) %	O <sub>2</sub> (dry) %	CO ppm <sub>dv</sub>	NO <sub>x</sub> Corrected to 7% O <sub>2</sub> (dry) ppm <sub>dv</sub>	SO <sub>2</sub> ppm <sub>dv</sub>	HC (wet) ppm <sub>wv</sub>	O <sub>2</sub> (wet) %
Daily Average	11.7	2974	136	238	—	4.7						
1-Hour Maximum		10654	194	406	—							
2-Hour Maximum		9494	194	342	—							
3-Hour Maximum		6856	179	306	—							
Hours of Recorded Data		11	11	11								

UNIT DOWN

(1) Unusual conditions include plant upset, unusual fuel, startup, and shutdown.

TABLE 5-33 (continued)  
CEM DATA  
SECOND WEEK, DAILY, INCLUDING UNUSUAL CONDITIONS(1)

	Friday, February 18, 1983					Saturday, February 19, 1983						
	O <sub>2</sub> (dry) %	CO ppm <sub>dv</sub>	NO <sub>x</sub> Corrected to 7% O <sub>2</sub> (dry) ppm <sub>dv</sub>	SO <sub>2</sub> ppm <sub>dv</sub>	HC (wet) ppm <sub>wv</sub>	O <sub>2</sub> (dry) %	O <sub>2</sub> (dry) %	CO ppm <sub>dv</sub>	NO <sub>x</sub> Corrected to 7% O <sub>2</sub> (dry) ppm <sub>dv</sub>	SO <sub>2</sub> ppm <sub>dv</sub>	HC (wet) ppm <sub>wv</sub>	O <sub>2</sub> (wet) %
Daily Average	12.8	1918	134	—	—	5.9	UNIT DOWN					
1-Hour Maximum		11100	157	—	—							
2-Hour Maximum		7416	151	—	—							
3-Hour Maximum		5896	150	—	—							
Hours of Recorded Data		16	16	—	—							
	Sunday, February 20, 1983					Monday, February 21, 1983						
	O <sub>2</sub> (dry) %	CO ppm <sub>dv</sub>	NO <sub>x</sub> Corrected to 7% O <sub>2</sub> (dry) ppm <sub>dv</sub>	SO <sub>2</sub> ppm <sub>dv</sub>	HC (wet) ppm <sub>wv</sub>	O <sub>2</sub> (wet) %	O <sub>2</sub> (dry) %	CO ppm <sub>dv</sub>	NO <sub>x</sub> Corrected to 7% O <sub>2</sub> (dry) ppm <sub>dv</sub>	SO <sub>2</sub> ppm <sub>dv</sub>	HC (wet) ppm <sub>wv</sub>	O <sub>2</sub> (wet) %
Daily Average	13.9	2501	108	—	—	5.3	11.7	1407	116	—	—	5.8
1-Hour Maximum		8206	136	—	—			1979	126	—	—	
2-Hour Maximum		5938	128	—	—			1900	124	—	—	
3-Hour Maximum		5138	125	—	—			1922	120	—	—	
Hours of Recorded Data		10	10	—	—			8	8	—	—	

(1) Unusual conditions include plant upset, unusual fuel, startup, and shutdown.

**TABLE 5-33 (continued)**  
**CEM DATA**  
**SECOND WEEK, DAILY, INCLUDING UNUSUAL CONDITIONS<sup>(1)</sup>**

WEEKLY TOTALS

	O <sub>2</sub> (dry) %	CO Corrected to 7% O <sub>2</sub> (dry) ppm <sub>dv</sub>	NO <sub>x</sub> Corrected to 7% O <sub>2</sub> (dry) ppm <sub>dv</sub>	SO <sub>2</sub> (dry) ppm <sub>dv</sub>	HC (wet) ppm <sub>wv</sub>	O <sub>2</sub> (wet) %
Monday	11.3	494	191	—	—	7.2
Tuesday	8.3	758	151	—	—	6.0
Wednesday	11.7	2974	136	238	—	4.7
Thursday	—	—	—	—	—	—
Friday	12.8	1918	134	—	—	5.9
Saturday	—	—	—	—	—	—
Sunday	13.9	2501	108	—	—	5.3
Monday	11.7	1407	116	—	—	5.8
Weighted Weekly Average	11.5	1528	143	238		5.8
# Hours of Recorded Data		81	81	11		
		ppm <sub>dv</sub>	ppm <sub>dv</sub>	ppm <sub>dv</sub>	ppm <sub>wv</sub>	
Worst:						
1-Hour		11100	241	406		
2-Hour		9494	218	342		
3-Hour		6856	218	306		
Daily Average		2974	191	238		

(1) Unusual conditions include plant upset, unusual fuel, startup, and shutdown.

TABLE 5-34  
CEM DATA SUMMARY

UNUSUAL CONDITIONS <sup>(1)</sup>							TYPICAL CONDITIONS								
FIRST WEEK TOTALS							FIRST WEEK TOTALS								
		O <sub>2</sub> (dry) %	CO Corrected to ppm <sub>dv</sub>	NO <sub>x</sub> % ppm <sub>dv</sub>	SO <sub>2</sub> O <sub>2</sub> (dry) ppm <sub>dv</sub>	HC (wet) ppm <sub>wv</sub>	O <sub>2</sub> (wet) %			O <sub>2</sub> (dry) %	CO Corrected to ppm <sub>dv</sub>	NO <sub>x</sub> % ppm <sub>dv</sub>	SO <sub>2</sub> O <sub>2</sub> (dry) ppm <sub>dv</sub>	HC (wet) ppm <sub>wv</sub>	O <sub>2</sub> (wet) %
2-7	Mon.	9.5	278	174	81	9.9	6.6	Mon.	9.5	235	169	74	9.9	6.6	
2-8	Tues.	8.6	564	169	141	32.2	6.5	Tues.	8.6	564	169	141	32.2	6.5	
2-9	Wed.	9.8	622	147	266	40.1	6.2	Wed.	9.8	622	147	166	40.1	6.2	
2-10	Thurs.	11.2	598	140	171	22.4	5.5	Thurs.	11.2	598	140	171	22.4	5.5	
2-11	Fri.	8.2	744	131	225	6.7	5.3	Fri.	8.2	668	128	228	6.7	5.3	
2-12	Sat.	7.8	318	122	—	—	5.3	Sat.	7.8	318	122	—	—	5.3	
2-13	Sun.	8.3	287	148	260	—	5.7	Sun.	8.3	287	148	260	—	5.7	
2-14	Mon.	PLANT UPSET							Mon.	PLANT UPSET					
Weighted Weekly Average								Weighted Weekly Average							
		9.1	509	147	191	22.1	5.9		9.1	494	143	182	22.1	5.9	
			ppm <sub>dv</sub>	ppm <sub>dv</sub>	ppm <sub>dv</sub>	ppm <sub>wv</sub>				ppm <sub>dv</sub>	ppm <sub>dv</sub>	ppm <sub>dv</sub>	ppm <sub>wv</sub>		
Worst								Worst							
1-Hr			2490	240	1328	155.3		1-Hr		2055	211	651	155.3		
2-Hr			1853	216	1068	—		2-Hr		1853	194	508	—		
3-Hr			1421	209	936	—		3-Hr		1172	193	454	—		
Daily			744	174	266	40.1		Daily		668	169	260	40.1		
# Hours of Recorded Data			135	134	113	25		# Hours of Recorded Data		132	129	97	25		

(1) Unusual conditions include plant upset, unusual fuel, startup, and shutdown.

TABLE 5-34 (continued)  
CEM DATA SUMMARY

		UNUSUAL CONDITIONS <sup>(1)</sup>						TYPICAL CONDITIONS								
		SECOND WEEK TOTALS						SECOND WEEK TOTALS								
		O <sub>2</sub> (dry)	CO Corrected to 7% O <sub>2</sub>	NO <sub>x</sub>	SO <sub>2</sub>	HC (wet)	O <sub>2</sub> (wet)			O <sub>2</sub> (dry)	CO Corrected to 7% O <sub>2</sub>	NO <sub>x</sub>	SO <sub>2</sub>	HC (wet)	O <sub>2</sub> (wet)	
		%	PPM <sub>dv</sub>	PPM <sub>dv</sub>	PPM <sub>dv</sub>	PPM <sub>wv</sub>	%			%	PPM <sub>dv</sub>	PPM <sub>dv</sub>	PPM <sub>dv</sub>	PPM <sub>wv</sub>	%	
2-14	Mon.	11.3	494	191	—	—	7.2	Mon	11.3	494	191	—	—	—	7.2	
2-15	Tues.	8.3	758	151	—	—	6.0	Tues.	8.3	758	151	—	—	—	6.0	
2-16	Wed.	11.7	2974	136	238	—	4.7	Wed.	11.7	779	138	178	—	4.7		
2-17	Thurs.		PLANT UPSET						Thurs.		PLANT UPSET					
2-18	Fri.	12.8	1918	134	—	—	5.9	Fri.	12.8	DATA UNUSABLE						5.9
2-19	Sat.		PLANT UPSET						Sat.		PLANT UPSET					
2-20	Sun.	13.9	2501	108	—	—	5.3	Sun	13.9	DATA UNUSABLE						5.3
2-21	Mon.	11.7	1407	116	—	—	5.8	Mon.	11.7	DATA UNUSABLE						
Weighted Weekly Average		11.5	1528	143	238	—	5.8	Weighted Weekly Average		11.6	686	160	178	—	5.8	
			PPM <sub>dv</sub>	PPM <sub>dv</sub>	PPM <sub>dv</sub>	PPM <sub>wv</sub>					PPM <sub>dv</sub>	PPM <sub>dv</sub>	PPM <sub>dv</sub>	PPM <sub>wv</sub>		
Worst 1-Hr			11,100	241	406	—		Worst 1-Hr			1,451	241	265	—		
Worst 2-Hr			9,494	218	342	—		Worst 2-Hr			1,269	218	215	—		
Worst 3-Hr			6,856	218	306	—		Worst 3-Hr			1,041	218	216	—		
Worst Daily			2,974	191	238	—		Worst Daily			779	191	178	—		
# Hours of Recorded Data			81	81	11	—		# Hours of Recorded Data			42	42	6	—		

(1) Unusual conditions include plant upset, unusual fuel, startup, and shutdown.

TABLE 5-34 (continued)  
CEM DATA SUMMARY

	UNUSUAL CONDITIONS <sup>(1)</sup>				TYPICAL CONDITIONS			
	TWO WEEK TOTALS				TWO WEEK TOTALS			
	CO Corrected to 7% O <sub>2</sub> dry ppm <sub>dv</sub>	NO <sub>x</sub> ppm <sub>dv</sub>	SO <sub>2</sub> O <sub>2</sub> dry ppm <sub>dv</sub>	HC (wet) ppm <sub>wv</sub>	CO Corrected to 7% O <sub>2</sub> dry ppm <sub>dv</sub>	NO <sub>x</sub> ppm <sub>dv</sub>	SO <sub>2</sub> O <sub>2</sub> dry ppm <sub>dv</sub>	HC (wet) ppm <sub>wv</sub>
<b>Worst Case:</b>					<b>Worst Case:</b>			
Daily	2,974	191	266	40.1	Daily	779	191	40.1
1-Hr	11,100	241	1,328	155.3	1-Hr	2,055	241	155.3
2-Hr	9,494	218	1,068	—	2-Hr	1853	218	—
3-Hr	6,856	218	936	—	3-Hr	1172	218	—
<b>Two Week Daily Weighted Average</b>	<b>891</b>	<b>145</b>	<b>195</b>	<b>22.1</b>	<b>Two Week Daily Weighted Average</b>	<b>540</b>	<b>147</b>	<b>22.1</b>
<b># Hours of Recorded Data</b>	<b>216</b>	<b>215</b>	<b>124</b>	<b>25</b>	<b># Hours of Recorded Data</b>	<b>174</b>	<b>171</b>	<b>25</b>

(1) Unusual conditions include plant upset, unusual fuel, startup, and shutdown.

2. EMISSION RATES AND EMISSION FACTORS FOR CO, NO<sub>x</sub> AND SO<sub>2</sub>

The concentration of the pollutants measured by CEM were converted to emission rates using representative volumetric flow data. As discussed in Section 5, Subsection C, and applied to particulates in Section 5, Subsection D, the flow rates measured during the U.S. EPA Method 101 and Method 5/8 sampling are the most representative of the in-duct flow rates. Emission rates were calculated by summarizing the CEM data during the sampling times and converting concentration to pounds per hour as shown in Tables 5-35 and 5-36. Emission factors in pounds per ton are presented in Table 5-35, and emission factors in pounds per million Btu are presented in Table 5-36. For each table a comparison of feed rate during sampling and during the day are shown. The similarity in both feed rates indicate that the rates during sampling were representative of the rates during the entire day. The emission factors reported in Table 2-1 and 2-2 are those taken during sampling because the flue gas flow rates were more representative during that time.

For a comparison to Kure, the emission factors for CO, NO<sub>x</sub> and SO<sub>2</sub> in lb/10<sup>6</sup> Btu during sampling at Gallatin averaged 0.631, 0.303 and 0.424, respectively, and at Kure averaged 0.710, 0.280, and 0.271, respectively.

3. EMISSION FACTORS IN LB/10<sup>6</sup> BTU USING U.S. EPA F-FACTORS FOR CO, NO<sub>x</sub>, AND SO<sub>2</sub>

Tables 5-37, 5-38 and 5-39 present emission factors for CO, NO<sub>x</sub> and SO<sub>2</sub>, respectively, during the daily sampling using U.S. EPA F<sub>d</sub> factors presented in Subsection 5.D.3. The average U.S. EPA emission factors present for CO, NO<sub>x</sub> and SO<sub>2</sub> are 0.459, 0.230 and 0.293 lb/10<sup>6</sup> Btu, respectively. Table 5-40 presents the emission factors for NMHC during the daily sampling using U.S. EPA F<sub>d</sub> factors with the volume of water taken into account. These emission factors, calculated in this manner, do not take into consideration the approximately 7% unburned combustibles in the residue that is reflected in the net heat input calculated in Table 5-9. Table 5-41 has emission factors based on net heat values, which has the effect of raising the emission factors by about 7%.

**TABLE 5-35**  
**EMISSION FACTORS (LB/TON) FOR CO, NO<sub>x</sub> AND SO<sub>2</sub>**  
**CALCULATED FROM CEM DATA TAKEN DURING SAMPLING**

<u>Date &amp; Time</u>	<u>EMISSION RATE (LB/HR)</u>			<u>FEED RATE (TPH)</u>		<u>EMISSION FACTORS (LB/TON)</u>					
	<u>CO</u>	<u>NO<sub>x</sub></u>	<u>SO<sub>2</sub></u>	<u>During Sampling</u>	<u>Daily Avg.</u>	<u>CO</u>		<u>NO<sub>x</sub></u>		<u>SO<sub>2</sub></u>	
						<u>During Sampling</u>	<u>Daily Avg.</u>	<u>During Sampling</u>	<u>Daily Avg.</u>	<u>During Sampling</u>	<u>Daily Avg.</u>
2/7/83 1050 to 1437	10.22	10.25	2.94	3.88	3.86	2.6	2.6	2.6	2.6	0.76	0.76
2/8/83 0855 to 1150	37.82	10.44	9.41	3.81	4.0	9.9	9.5	2.7	2.6	2.5	2.4
2/8/83 1320 to 1500	6.31	10.16	9.23	4.63	4.0	1.4	1.6	2.2	2.5	2.0	2.3
2/8/83 1647 to 1825	9.25	9.92	9.71	5.06	4.0	1.8	2.3	2.0	2.5	1.9	2.4
2/9/83 0940 to 1215	18.42	6.59	10.48	4.12	3.79	4.5	4.9	1.6	1.7	2.5	2.8
2/11/83 1552 to 1735	25.23	7.27	26.70	3.86	3.3	6.5	7.6	1.9	2.2	6.9	8.1
<b>AVERAGE</b>						4.5	4.8	2.2	2.4	2.8	3.1



**TABLE 5-36**  
**EMISSION FACTORS (LB/10<sup>6</sup> BTU) FOR CO, NO<sub>x</sub> AND SO<sub>2</sub>**  
**CALCULATED FROM CEM DATA TAKEN DURING SAMPLING**

Date & Time	EMISSION RATE (LB/HR)			NET HEAT INPUT RATE (10 <sup>6</sup> BTU/HR)		EMISSION FACTORS (LB/10 <sup>6</sup> BTU)					
	CO	NO <sub>x</sub>	SO <sub>2</sub>	During Sampling	Daily Avg.	CO		NO <sub>x</sub>		SO <sub>2</sub>	
						During Sampling	Daily Avg.	During Sampling	Daily Avg.	During Sampling	Daily Avg.
2/7/83 1050 to 1437	10.22	10.25	2.94	35.58	35.58	0.287	0.287	0.288	0.288	0.0826	0.0826
2/8/83 0855 to 1150	37.82	10.44	9.41	30.59	31.40	1.24	1.20	0.341	0.332	0.308	0.300
2/8/83 1320 to 1500	6.31	10.16	9.23	32.96	31.40	0.191	0.200	0.308	0.324	0.280	0.294
2/8/83 1647 to 1825	9.25	9.92	9.71	30.65	31.40	0.302	0.295	0.324	0.316	0.317	0.309
2/9/83 0940 to 1215	18.42	6.59	10.48	28.41	30.11	0.648	0.612	0.232	0.219	0.368	0.348
2/11/83 1552 to 1735	25.23	7.27	26.70	22.51	22.51	1.12	1.12	0.323	0.323	1.19	1.19
<b>AVERAGE</b>						<b>0.631</b>	<b>0.619</b>	<b>0.303</b>	<b>0.300</b>	<b>0.424</b>	<b>0.421</b>

TABLE 5-37

**CO EMISSION FACTORS USING U.S. EPA F-FACTOR  
CALCULATED FROM CEM DATA TAKEN DURING SAMPLING**

$$E = \frac{Cd Fd (20.9)}{(20.9 - \%O_2)}$$

E = Pollutant Emission Rate, lb/10<sup>6</sup> Btu

Cd = Pollutant Concentration (dry) lb/scf  
= ppm<sub>dv</sub> CO at 7% O<sub>2</sub> x 0.7276x10<sup>-7</sup>

% O<sub>2</sub> = 7% O<sub>2</sub> dry

Date	CO Conc. at 7% O <sub>2</sub>	Cd x 10 <sup>-7</sup> (lb/scf)	Fd (scf/10 <sup>6</sup> Btu)	E (lb/10 <sup>6</sup> Btu)
2/7/83 1050 TO 1437	254	184.81	8,875	0.247
2/8/83 0855 TO 1150	928	675.21	9,019	0.916
2/8/83 1320 TO 1500	150	109.14	9,973	0.164
2/8/83 1647 TO 1825	222	161.53	9,168	0.223
2/9/83 0940 TO 1215	482	350.70	7,803	0.411
2/11/83 1552 TO 1735	<u>650</u>	<u>472.94</u>	<u>11,395</u>	<u>0.810</u>
<b>AVERAGE</b>	448	325.96	9,372	0.459

**TABLE 5-38**  
**NO<sub>x</sub> EMISSION FACTORS USING U.S. EPA F-FACTOR**  
**CALCULATED FROM CEM DATA TAKEN DURING SAMPLING**

$$E = Cd Fd \left( \frac{20.9}{20.9 - \%O_2} \right)$$

E = Pollutant Emission Rate, lb/10<sup>6</sup> Btu  
 Cd = Pollutant Concentration (dry) lb/scf  
 = ppm<sub>dv</sub> NO<sub>x</sub> at 7% O<sub>2</sub> x 1.194x10<sup>-7</sup>  
 % O<sub>2</sub> = 7% O<sub>2</sub> dry

Date	CO Conc. at 7% O <sub>2</sub>	Cd x 10 <sup>-7</sup> (lb/scf)	Fd (scf/10 <sup>6</sup> Btu)	E (lb/10 <sup>6</sup> Btu)
2/7/83 1050 TO 1437	155	185.07	8,875	0.247
2/8/83 0855 TO 1150	156	186.26	9,019	0.253
2/8/83 1320 TO 1500	147	175.52	9,973	0.263
2/8/83 1647 TO 1825	145	173.13	9,168	0.239
2/9/83 0940 TO 1215	105	125.37	7,803	0.147
2/11/83 1552 TO 1735	<u>114</u>	<u>136.12</u>	<u>11,395</u>	<u>0.233</u>
<b>AVERAGE</b>	137	163.58	9,372	0.230

TABLE 5-39

SO<sub>2</sub> EMISSION FACTORS USING U.S. EPA P-FACTOR

## CALCULATED FROM CEM DATA TAKEN DURING SAMPLING

$$E = Cd Fd \left( \frac{20.9}{20.9 - \%O_2} \right)$$

E = Pollutant Emission Rate, lb/10<sup>6</sup> Btu

Cd = Pollutant Concentration (dry) lb/scf

= ppm<sub>dv</sub> SO<sub>2</sub> at 7% O<sub>2</sub> x 1.66x10<sup>-7</sup>

% O<sub>2</sub> = 7% O<sub>2</sub> dry

Date	SO <sub>2</sub> Conc. at 7% O <sub>2</sub>	Cd x 10 <sup>-7</sup> (lb/scf)	Fd (scf/10 <sup>6</sup> Btu)	E (lb/10 <sup>6</sup> Btu)
2/7/83 1050 TO 1437	32	53.12	8,875	0.071
2/8/83 0855 TO 1150	101	167.66	9,019	0.227
2/8/83 1320 TO 1500	96	159.36	9,973	0.238
2/8/83 1647 TO 1825	102	169.32	9,168	0.238
2/9/83 0940 TO 1215	120	199.20	7,803	0.234
2/11/83 1552 TO 1735	<u>301</u>	<u>499.66</u>	<u>11,395</u>	<u>0.856</u>
<b>AVERAGE</b>	125	208.50	9,372	0.293

**TABLE 5-40**

**NMHC EMISSION FACTORS USING U.S. EPA F-FACTOR  
CALCULATED FROM CEM DATA TAKEN DURING SAMPLING**

$$E = \frac{(Cd)(Fd)}{(1-Bws)} \left( \frac{20.9}{(20.9 - \%O_2)} \right)$$

E = Pollutant Emission Rate, lb/10<sup>6</sup> Btu

Cw = Pollutant Concentration (w) lb/scf  
= ppm<sub>wv</sub> NMHC x 0.4158x10<sup>-7</sup>

Bws = Proportion by vol. of water vapor  
in stack gas

Date	NMHC Conc. (ppm <sub>wv</sub> wet)	O <sub>2</sub> (%)	Bws % Vol.	Cw (lb/scf)	Fd (scf/10 <sup>6</sup> Btu)	E (lb/10 <sup>6</sup> Btu)
2/7/83 1050 TO 1437	12	9.0	14.6	4.99	8,875	0.0091
2/8/83 0855 TO 1150	17.1	10.2	16.0	7.11	9,019	0.0149
2/8/83 1320 TO 1500	30.7	10.6	13.8	12.77	9,973	0.0300
2/8/83 1647 TO 1825	85.2	12.8	15.9	35.43	9,168	0.0997
2/9/83 0940 TO 1215	90	8.7	15.5	37.42	7,803	0.0592
2/11/83 1552 TO 1735	<u>5.9</u>	<u>8.6</u>	<u>15.9</u>	<u>2.45</u>	<u>11,395</u>	<u>0.0056</u>
<b>AVERAGE</b>	40.2	10.0	15.3	16.70	9,372	0.0354

**TABLE 5-41**  
**EMISSION FACTORS USING U.S. EPA F-FACTOR BASED ON NET HEATING VALUE**

Date & Time	Net Heat Rate 10 <sup>6</sup> Btu/Hr	MSW Heat Input 10 <sup>6</sup> Btu/Hr	Emission Factors (lb/10 <sup>6</sup> Btu)			
			Based on Net Heat Input			
			CO	NO <sub>x</sub>	SO <sub>2</sub>	NMHC
2/7/83 1050 to 1437	35.58	37.33	0.259	0.259	0.075	0.0095
2/8/83 0855 to 1150	30.59	33.27	0.996	0.275	0.247	0.0162
1320 to 1500	32.96	35.97	0.179	0.287	0.260	0.0327
1647 to 1825	30.65	32.10	0.234	0.250	0.244	0.1044
2/9/83 0940 to 1215	28.41	31.02	0.449	0.161	0.256	0.0646
2/11/83 1552 to 1735	22.51	24.84	0.894	0.257	0.945	0.0062
<b>AVERAGE</b>			<b>0.502</b>	<b>0.248</b>	<b>0.338</b>	<b>0.0389</b>

4. MULTIVARIABLE REGRESSION ANALYSES OF PLANT OPERATING DATA AND EMISSIONS OF CO, NO<sub>x</sub>, AND SO<sub>2</sub> BY RIGO & RIGO ASSOCIATES

The plant and emissions monitoring data (5 minute points) recorded during the February 1983 testing of the Gallatin Plant were introduced into a computerized data base and analyzed to uncover the relationship between emissions and operator controllable plant parameters (e.g., steam generation rate and excess air). Because of the range of data, the analysis was performed using regression techniques to create mathematical models of the plant's performance. These models were then examined to determine which parameters were significant.

The major findings are:

- o Unlike fossil fuel-fired boilers, NO<sub>x</sub> emissions at Gallatin decrease with increasing boiler load and display a moderate increasing trend with oxygen.

The combined effect of load and oxygen displays a strong negative impact on NO<sub>x</sub> emissions. Emissions are slightly increased when NRT-prepared fuel is burned but are lower when plant operations are not stable. How the plant is operated also has an effect because emissions change with changes in shift.

- o CO emissions are not as reliably predicted as NO<sub>x</sub> emissions and they display opposite trends to NO<sub>x</sub>; CO increases with load and at an ever increasing rate with oxygen. Burning NRT fuel tends to increase the emissions and there is a pronounced shift change effect. Surprisingly, CO emissions are the same during normal and abnormal operations.
- o SO<sub>2</sub> emissions increase with boiler load and oxygen. They are independent of shift changes but are strongly related to the same parameter that describes abnormal plant operations. This implies that whatever is in the fuel to contribute unusually large quantities of SO<sub>2</sub> also causes the furnace operation to become unstable.
- o NMHC and HCl emissions seem to be uncorrelated with any of the plant operating parameters.

These findings, the method of analysis and the data bases are described in the Appendix, Part 5. The regression equations for the full data set are shown in Table 5-42.

**TABLE 5-42  
REGRESSION EQUATIONS**

LPMBNOX = 0.1132958 + 0.03489479 O2DRY - 0.001180662 O2SQRD  
 - 0.0002196939 LOADO2 + 0.01517709 NRTBRN  
 - 0.007888894 OUTCNTRL + 0.02875142 SHIFT2  
 + 0.01133201 SHIFT3

LNLPMBCO = - 5.476 + 0.03391374 LOAD + 0.3172171 O2DRY  
 + 0.03395511 O2SQRD - 0.05248284 NO2SQRD  
 + 0.06709716 NLOAD + 0.7407957 NO2DRY  
 - 0.002454303 LOADO2 - 0.008083078 NLOADO2  
 - 5.432200 NRTBRN + 0.1647436 OUTCNTRL

LNLPMBSO = - 3.033080 + 0.01398806 LOAD + 0.04177209 O2DRY  
 + 0.008429740 O2SQRD + 0.4187657 NRTBRN  
 - 0.05770778 NO2DRY + 0.7039509 OUTCNTRL  
 - 0.1729842 SHIFT2 + 0.01130180 SHIFT3

LPMBHC = - 0.007887794 + 0.003533881 O2DRY

---

LPMBNOX	=	lb/MMBtu NO <sub>x</sub>
O2DRY	=	O <sub>2</sub> concentration in dry gas, %
O2SQRD	=	(O2DRY - 9.663) <sup>2</sup>
LOADO2	=	Product of LOAD and O2DRY
LOAD	=	Percent of maximum continuous rating achieved
NRTBRN	=	Dummy variable indicating NRT fuel being fired
OUTCNTRL	=	Dummy variable indicating unusual process conditions
SHIFT2	=	Dummy variable to account for three shifts
SHIFT3	=	Dummy variable to account for three shifts
LNLPMBCO	=	Natural logarithm of lb/MMBtu CO
NO2SQRD	=	NRT burn period furnace parameters
NLOAD	=	NRT burn period furnace parameters
NO2DRY	=	NRT burn period furnace parameters
NLOADO2	=	NRT burn period furnace parameters
LNLPMBSO	=	Natural logarithm of lb/MMBtu SO <sub>2</sub>
LPMBHC	=	lb/MMBtu non-methane hydrocarbons



H. SO<sub>2</sub> AND SO<sub>3</sub> DATA USING U.S. EPA METHOD 8 AND SULFUR BALANCE

The rotary combustor outlet and Apitron outlet measurements for SO<sub>2</sub> and SO<sub>3</sub> were performed with combined U.S. EPA Method 5/8 sampling trains. The unabated concentrations for SO<sub>2</sub> and SO<sub>3</sub> are shown in Tables 5-43 and 5-44, respectively. All field data and calculation sheets for these unabated emissions are shown in the Appendix, Part 2.

The SO<sub>2</sub> results in Table 5-43 show a greater emission rate at the Apitron outlet than the combustor outlet. The difference is probably due to error from a combination of the air leak at the Apitron inlet and from a higher flow due to velocity measurement error.

The unabated emission factors for SO<sub>2</sub> were 2.38 lb/ton and 0.300 lb/10<sup>6</sup> Btu while the unabated emission factors for CEM data taken during sampling on 2/8/83 at 1320 were 2.0 lb/ton and 0.280 lb/10<sup>6</sup> Btu.

The sulfate results presented in Table 5-44 show a reduction from the rotary combustor outlet to the Apitron outlet of 62.1 ppm<sub>dv</sub> and 51.8 ppm<sub>dv</sub> to 32.6 ppm<sub>dv</sub> and 30.5 ppm<sub>dv</sub> on 2/8/83 at 1321 and 1647, respectively. The reduction of 29 to 21 ppm<sub>dv</sub> of SO<sub>3</sub> may be due in part to the formation of NH<sub>4</sub>HSO<sub>4</sub> by the reaction with ammonia (see Section 5, Subsection L) or to the formation of an acid mist such as H<sub>2</sub>SO<sub>4</sub>.

A sulfur balance for the system is shown in Table 5-45. This table also shows the retention of sulfur in the residue, which is on the average of 15.4%. The sulfur balance suffers from the problem of obtaining representative data on sulfur concentrations from samples of the MSW and the residue for the same time period as the CEM data.

**TABLE 5-43**  
**SO<sub>2</sub> EMISSIONS AND EMISSION FACTORS USING U.S. EPA METHOD 5/8**

**COMBUSTOR OUTLET:**

Date & Time	SO <sub>2</sub> Conc. (ppm <sub>dv</sub> ) at	Actual O <sub>2</sub>	SO <sub>2</sub> Conc. at 7% O <sub>2</sub>	Emission Rate (lb/hr)	Feed Rate		Emission Factors	
					TPH	10 <sup>6</sup> Btu/hr	lb/ton	lb/10 <sup>6</sup> Btu
2/8/83 1321 to 1500	86.6	10.6	117	8.34	4.0	32.96	2.09	0.253
1647 to 1825	<u>111.5</u>	<u>12.8</u>	<u>191</u>	<u>10.63</u>	<u>4.0</u>	<u>30.65</u>	<u>2.66</u>	<u>0.347</u>
<b>AVERAGE</b>			154	9.49			2.38	0.300

**APITRON OUTLET:**

2/8/83 1322 to 1507	105.2	10.0	134	14.57	4.0	32.96	3.64	0.442
1648 to 1830	<u>96.0</u>	<u>11.9</u>	<u>148</u>	<u>13.39</u>	<u>4.0</u>	<u>30.65</u>	<u>3.35</u>	<u>0.437</u>
<b>AVERAGE</b>			141	13.98			3.50	0.440

**TABLE 5-44  
SULFATE EMISSIONS AND EMISSION FACTORS USING U.S. EPA METHOD 5/8**

**COMBUSTOR OUTLET:**

<u>Date &amp; Time</u>	<u>SO<sub>3</sub> Conc. (ppm<sub>dv</sub>)</u>	at	<u>Actual O<sub>2</sub></u>	<u>SO<sub>3</sub> Conc. at 7% O<sub>2</sub></u>	<u>Emission Rate<sup>(1)</sup> (lb/hr)</u>	<u>Feed Rate</u>		<u>Emission Factors</u>	
						<u>TPH</u>	<u>10<sup>6</sup> Btu/hr</u>	<u>lb/ton</u>	<u>lb/10<sup>6</sup> Btu</u>
2/8/83 1321 to 1500	62.1		10.6	83.8	9.04	4.0	32.96	2.26	0.274
1647 to 1825	51.8		12.8	<u>88.9</u>	<u>7.47</u>	4.0	30.65	<u>1.87</u>	<u>0.244</u>
<b>AVERAGE</b>				86.4	8.26			2.07	0.259

**APITRON OUTLET:**

2/8/83 1322 to 1507	32.6		10.0	41.6	6.84	4.0	32.96	1.71	0.208
1648 to 1830	<u>30.5</u>		<u>11.9</u>	<u>47.1</u>	<u>6.44</u>	<u>4.0</u>	<u>30.65</u>	<u>1.61</u>	<u>0.210</u>
<b>AVERAGE</b>					6.64			1.66	0.209

(1) Calculated as H<sub>2</sub>SO<sub>4</sub> (molecular weight 98).

**TABLE 5-45  
SULFUR MATERIAL BALANCE**

Date & Time	Sulfur in MSW Input		Sulfur in Residue			Sulfur in <sup>(4)</sup> Combustion gas		Unaccounted Sulfur	
	dry Wt % S	S lb/hr	dry Wt % S	S lb/hr	% Of Input	SO <sub>2</sub> <sup>(1)</sup> lb/hr	SO <sub>3</sub> <sup>(3)</sup> lb/hr	lb/hr	% Of Input
2/7/83 1040 to 1120	0.09	4.46	0.05	1.44	32.3	1.47	0.8	0.75	17
2/8/83 0910 to 1015	0.61	26.1	1.11	16.4	62.8	4.71	2.7	2.29	9
1340 to 1440	1.10	63.2	0.01	0.07	0.1	4.62	3.0 <sup>(2)</sup>	55.5	88
1700 to 1720	0.70	31.3	0.01	0.30	1.0	4.86	2.4 <sup>(2)</sup>	23.7	76
2/9/83 0950 to 1020	5.10	230.	0.23	2.11	0.9	5.24	3.0	220.	96
1400 to 1420	2.40	111.	0.09	0.72	0.6	—	—	—	—
2/10/83 0910 to 0920	1.90	73.9	1.0	14.0	18.9	—	—	—	—
1410 to 1440	1.84	74.9	0.7	7.1	9.5	—	—	—	—
2/11/83 1600 to 1630	0.97	36.3	0.21	4.4	12.1	13.4	7.6	10.9	30
<b>AVERAGE</b>	1.63	122.6	0.38	5.2	15.4				

(1) SO<sub>2</sub> emission rates from Table 5-35.

(2) SO<sub>3</sub> emission rates from Table 5-43.

(3) SO<sub>3</sub> emission calculation from SO<sub>2</sub> based on SO<sub>2</sub>/SO<sub>3</sub> ratio of 2/8/83 — 1340 to 1440 and 1700 to 1720.

(4) Sulfur content of SO<sub>2</sub> and SO<sub>3</sub> at the combustor outlet.

I. NON-METHANE HYDROCARBONS (NMHC)

The unabated non-methane hydrocarbons were sampled at the gas air heater outlet using the Byron 401 emission analyzer. A sample from the duct is drawn through the analyzer and analyzed in a 12-minute cycle. The results of the analyses and the emission rates and emission factors at the representative sampling conditions are presented in Table 5-46. All field data and calculation sheets for these unabated emissions are shown in the Appendix, Part 2.

Table 5-46 presents the measured emission factors for NMHC. The hydrocarbon concentration is determined by the analyzer on a wet basis so all subsequent calculations must be correspondingly on a wet basis.

J. HCl

The unabated HCl was sampled along with fluoride and ammonia as part of an acid gas train or with the multiclone train at the rotary combustor outlet and analyzed by ion chromatography. The hydrogen chloride concentration in the duct and the concentration adjusted to 7% O<sub>2</sub> are presented in Table 5-47. This table also shows emission rate and emission factors. All field data and calculation sheets for the chloride emissions are shown in the Appendix, Part 2.

**TABLE 5-46**  
**NON-METHANE HYDROCARBONS (NMHC) CONCENTRATIONS, EMISSION RATES**  
**AND EMISSION FACTORS AT THE COMBUSTOR OUTLET, FEBRUARY 7-11, 1983**

Date & Time	CEM Concentration During Sampling (ppm <sub>wv</sub> at actual O <sub>2</sub> ) <sup>(1)</sup>	Emission Rate (lb/hr) <sup>(2)</sup>	Feed Rate		Emission Factors	
			TPH	10 <sup>6</sup> Btu/hr	lb/ton	lb/10 <sup>6</sup> Btu
2/7/83 1050 to 1437	12	0.324	3.88	35.58	0.0835	0.00911
2/8/83 0855 to 1150	17.1	0.475	3.81	30.59	0.125	0.0155
2/8/83 1320 to 1500	30.7	0.858	4.63	32.96	0.185	0.0291
2/8/83 1647 to 1825	85.2	2.42	5.06	30.65	0.478	0.0790
2/9/83 0940 to 1215	90	2.33	4.12	28.41	0.566	0.0820
2/11/83 1552 to 1735	5.9	0.156	3.86	22.51	0.0404	0.00693
<b>AVERAGE</b>	40.2				0.232	0.0369

(1) Data as ppm<sub>wv</sub> carbon

(2) Data as methane, MW of 16.

**TABLE 5-47  
UNABATED HCl EMISSIONS AND EMISSION FACTORS**

<u>Date &amp; Time</u>	<u>HCl Conc. ppm<sub>dv</sub></u>	<u>at</u>	<u>Actual O<sub>2</sub></u>	<u>HCl Conc. ppm<sub>dv</sub> at 7% O<sub>2</sub></u>	<u>Emission Rate (lb/hr)</u>	<u>Feed Rate</u>		<u>Emission Factors</u>	
						<u>TPH</u>	<u>10<sup>6</sup> Btu/hr</u>	<u>lb/ton</u>	<u>lb/10<sup>6</sup> Btu</u>
2/8/83 1030 to 1056	238		10.0	303.5	12.9	4.0	32.96	3.23	0.391
2/8/83 1122 to 1146	385		10.5	514.6	20.8	4.0	32.96	5.2	0.631
2/9/83 1107 to 1134	363		10.8	499.6	18.0	3.79	28.41	4.75	0.634
2/9/83 1210 to 1237	242		13.4	448.5	12.0	3.79	28.41	3.17	0.422
2/9/83 1321 to 1347	243		9.5	296.3	12.1	3.79	31.80	3.19	0.381
2/9/83 1452 to 1513	438		10.0	588.6	21.8	3.79	31.80	5.75	0.686
2/10/83 1000 to 1020	219		11.2	313.8	11.8	3.67	25.48	3.22	0.463
2/10/83 1102 to 1129	243		13.6	462.7	13.0	3.67	25.48	2.54	0.510
2/10/83 1019 to 1120	123		8.0	132.5	6.4	3.67	25.48	1.74	0.251
2/10/83 1345 to 1515	297		8.2	325.1	16.5	3.67	25.05	4.50	0.659
2/11/83 1007 to 1122	729		12.0	1,138.6	41.4	3.7	22.51	11.19	1.839
2/11/83 1300 to 1415	<u>924</u>		<u>9.4</u>	<u>1,116.8</u>	<u>50.9</u>	<u>3.7</u>	<u>22.51</u>	<u>13.76</u>	<u>2.261</u>
<b>AVERAGE</b>				509				5.27	0.761

West County Agency of Contra Costa County  
Waste Co-Disposal/Energy Recovery Project

July, 1984

K. HF

Fluoride emissions were sampled as HF in the gas stream and as the fluoride ion in the particulate. Table 5-48 presents the HF concentration in the gas stream when sampled as the back-half of the multiclone sampling train and when sampled by the acid gas train, as described in the Appendix, Part 1. Table 5-48 shows the concentration of the fluoride on the particulate from the multiclone. Similar to the heavy metal analysis, a portion of the multiclone catch was used for fluoride analysis. Fluoride was analyzed, along with the chloride, by ion chromatography. The acid gas train fluoride was a factor of 10 lower than the values from the multiclone backhalf numbers. It was concluded that the multiclone data should be used because the lower acid gas train numbers were probably caused by the hydrofluoric acid reacting with the glass absorber frits used in the acid gas train.

All field data and calculation sheets for the sampling are shown in the Appendix, Part 2.

Table 5-49 presents the distribution of the fluoride in the unabated particulate sampled at the rotary combustor outlet. Table 5-50 presents the sum of the unabated fluoride emission rates in the particulate and in the flue gas stream and the corresponding emission factors. A comparison of the fluorides in the flue gas stream measured at Kure is also presented. The emission rate in the gas stream at Kure is similar to that at Gallatin; however, the Kure factor does not include fluorides in the particulate.



**TABLE 5-48  
COMPARISON OF KURE AND VARIOUS GALLATIN TESTS FOR TOTAL  
FLUORIDES; CONCENTRATIONS OF FLUORIDE IN THE PARTICULATE  
AND OF HF IN THE GAS STREAM OF COLLECTION SAMPLES**

<u>Sample Location Date and Test Method</u>	<u>Fluoride On Particulate (ppm)</u>	<u>HF as Gas (ppm<sub>dv</sub> at 7% O<sub>2</sub>)</u>	<u>Sample Location Date and Test Method</u>	<u>HF as Gas (ppm<sub>dv</sub> at 7% O<sub>2</sub>)</u>
<b>KURE:</b> ESP Inlet 11/19/80 Grab Sample	701	3.06	<b>GALLATIN:</b> Combustor Outlet Acid Gas Samples:  2/8/83 1030 to 1056	    0.41
<b>GALLATIN:</b> Apitron Inlet 2/20/82 Grab Sample	760	—	1122 to 1146	0.24
Combustor Outlet 2/10/83 (1019-1120) #1 Multiclone (60.4% of total part. >10 $\mu$ )	2300	5.34	2/9/83 1107 to 1134 1210 to 1237 1321 to 1347 1452 to 1513	 0.61 0.17 0.29 0.46
Combustor Outlet 2/11/83 (1300-1415) #4 Multiclone (77.1% of total part. >10 $\mu$ )	950	0.81	2/10/83 1000 to 1020 1102 to 1139 AVERAGE	 0.74 0.74 0.46
Combustor Outlet 2/10/83 (1345-1515) #2 Multiclone (average of total part. <1 to >10 $\mu$ )	1036	3.45		
Combustor Outlet 2/11/83 (1007-1122) #3 Multiclone (average of total part. <1 to >10 $\mu$ )	1171	6.76		
AVERAGE		4.09		

**TABLE 5-49  
UNABATED FLUORIDE DISTRIBUTION ON PARTICULATE**

Date & Time	Mean Cut Diameter (microns): <1		1.0 to 1.8		3.9 to 5.2		>10		Total	
	Fluoride Fraction wt. (mg)	Fraction of Fluoride Wt %	Fluoride Fraction wt. (mg)	Fraction of Fluoride Wt %	Fluoride Fraction wt. (mg)	Fraction of Fluoride Wt %	Fluoride Fraction wt (mg)	Fraction of Fluoride Wt %	Total Particulate (mg)	Fluoride % of Total Particulate
2/10/83 1345 to 1515	0.1508	8.49	0.0519	2.92	0.3154	17.75	1.2588	70.84	1715.8	0.104
2/11/83 1007 to 1122	0.0876	3.46	0.0429	1.69	0.3279	12.96	2.0726	81.89	2160.7	0.117
<b>AVERAGE</b>	<b>0.1192</b>	<b>5.53</b>	<b>0.0474</b>	<b>2.20</b>	<b>0.3217</b>	<b>14.94</b>	<b>1.6657</b>	<b>77.33</b>	<b>1938.3</b>	<b>0.110</b>

**TABLE 5-50  
UNABATED FLUORIDE AND HF EMISSION RATES AND EMISSION FACTORS AT GALLATIN  
AND COMPARISON WITH KURE RESULTS**

<b>GALLATIN</b> <u>Date &amp; Time</u>	<u>EMISSION RATE (lb/hr)</u>				<u>FEED RATE</u>		<u>EMISSION FACTORS</u>		
	<u>Particulate</u>	+	<u>Gas</u>	=	<u>Total</u>	<u>TPH</u>	<u>10<sup>6</sup> Btu/hr</u>	<u>lb/ton</u>	<u>lb/10<sup>6</sup> Btu</u>
2/10/83 1345 TO 1515	0.0864		0.0962		0.1826	3.67	25.05	4.98x10 <sup>-2</sup>	7.29x10 <sup>-3</sup>
2/11/83 1007 to 1122	0.1454		0.1349		0.2803	3.7	22.51	7.58x10 <sup>-2</sup>	12.5x10 <sup>-3</sup>
<b>AVERAGE</b>	0.1159		0.1156		0.2315	—	—	6.28x10 <sup>-2</sup>	9.90x10 <sup>-3</sup>
<b>KURE</b>	—		0.124		—	—	—	1.79x10 <sup>-2</sup>	3.18x10 <sup>-3</sup>

## L. AMMONIA

Ammonia was added to the analysis of the acid gases sampled to determine whether the combustion of MSW resulted in its formation. The unabated  $\text{NH}_3$  was sampled along with chloride and fluoride, as part of the acid gas sampling train and as part of the back half of the multiclone train. The acid gas sampling was performed at the rotary combustor outlet. Table 5-51 shows that some ammonia is found in the flue gas and presents the unabated free ammonia gas emissions and emission factors. All field data and calculation sheets for the ammonia emissions are shown in the Appendix, Part 2.

As mentioned in Section 5, Subsection H, the unabated  $\text{SO}_3$  sampled on 2/8/83 was reduced about 22 to 30  $\text{ppm}_{\text{dV}}$  at the Apitron outlet (the stack). It can be assumed that the "front-half" (i.e., in the probe and on the filter)  $\text{SO}_4^-$  and the  $\text{NH}_3$  reacted because the "front-half"  $\text{SO}_4^-$  was held by a heated probe and filter. The "back half"  $\text{SO}_3$  and  $\text{NH}_3$ , by the same argument, were gases at the filter temperature because both the  $\text{SO}_3$  and  $\text{NH}_3$  went through the filter. With this, the following comments can be made about ammonia and sulfate/sulfur oxides by referring to Table 5-52:

- o About 50% of the  $\text{SO}_4^-$  is in the particulate form at the combustor outlet (at sampling train temperature of 290-300°F) but only about 2% of the  $\text{SO}_4^-$  is in the particulate form at the Apitron outlet. The data indicate that the cyclone and the Apitron are about 98% efficient for removing particulate  $\text{SO}_4^-$ .
- o There was an increase in gas phase  $\text{SO}_3/\text{H}_2\text{SO}_4$  across the unit, indicating that the unit has no effect on it.
- o Almost 90% of the ammonia is in the particulate form at the sampling train conditions, i.e., probe and filter at 290°F.
- o There were similar concentrations of particulate  $\text{SO}_4^-$  (29.97  $\text{ppm}_{\text{dV}}$ ) and  $\text{NH}_4^+$  (27.9  $\text{ppm}_{\text{dV}}$ ) which give the stoichiometric reaction to ammonia bisulfate ( $\text{NH}_4\text{HSO}_4$ ). These data do not rule out other cation and anion combinations.

**TABLE 5-51  
UNABATED NH<sub>3</sub> EMISSIONS AND EMISSION FACTORS**

<u>Date &amp; Time</u>	NH <sub>3</sub> Conc. ppm <sub>dv</sub>	O <sub>2</sub> % vol	NH <sub>3</sub> Conc. ppm <sub>dv</sub> at 7% O <sub>2</sub>	Emission Rate (lb/hr)	<u>Feed Rate</u>		<u>Emission Factors</u>	
					TPH	10 <sup>6</sup> Btu/hr	lb/ton	lb/10 <sup>6</sup> Btu
2/8/83 1030 to 1050	33.8	10.0	43.1	0.70	4.0	32.96	0.18	0.021
1122 to 1146	29.5	10.5	39.4	0.61	4.0	32.96	0.15	0.019
2/9/83 1107 to 1134	17.9	10.8	24.6	0.34	3.79	28.41	0.09	0.012
1210 to 1237	13.2	13.4	24.5	0.64	3.79	28.41	0.17	0.023
1321 to 1347	29.9	9.5	36.5	0.57	3.79	31.80	0.15	0.018
1452 to 1513	26.4	10.0	33.7	0.51	3.79	31.80	0.13	0.016
2/10/83 1000 to 1020	25.5	11.2	36.5	0.53	3.67	25.48	0.14	0.021
1102 to 1129	27.5	13.6	52.4	0.57	3.67	25.48	0.16	0.022
1019 to 1120 <sup>(1)</sup>	13.9	8.0	15.0	0.28	3.67	25.48	0.08	0.011
1345 to 1515 <sup>(1)</sup>	9.2	8.2	10.1	0.20	3.67	25.05	0.05	0.008
2/11/83 1007 to 1122 <sup>(1)</sup>	12.9	12.0	20.1	0.28	3.7	22.51	0.08	0.012
1300 to 1415	<u>12.0</u>	<u>9.4</u>	<u>14.5</u>	<u>0.26</u>	<u>3.7</u>	<u>22.31</u>	<u>0.07</u>	<u>0.012</u>
<b>AVERAGE</b>			29.2	0.46	3.77	27.72	0.121	0.016

(1) Samples were the back half of the multiclone.

**TABLE 5-52**  
**SO<sub>4</sub> AND NH<sub>3</sub> FORMS AT COMBUSTOR OUTLET AND APITRON OUTLET**

<u>All Data in ppm<sub>dv</sub></u>		<u>Front Half<sup>(1)</sup> SO<sub>4</sub>=</u>		<u>Back Half<sup>(1)</sup> SO<sub>4</sub>=</u>		<u>Total SO<sub>4</sub>=</u>	<u>Front Half NH<sub>3</sub> (2)</u>	<u>Back Half NH<sub>3</sub> (1)</u>	<u>Total NH<sub>3</sub> (3)</u>
<u>Outlet</u>	<u>Time</u>	<u>Nozzle and Probe</u>	<u>Filter</u>	<u>Condensibles</u>	<u>Demister Filter</u>				
Combustor	2/8/83	9.15	19.25	33.55	0.11	62.06	29.6	4.16	33.8
	1321-1500								
	SUBTOTAL	28.40		33.66					
Combustor	1647-1825	7.48	24.06	20.13	0.086	51.76	26.2	3.26	29.5
	SUBTOTAL	31.54		20.22					
Apitron	2/8/83	0.19	0.48	31.86	0.09	32.62	N/A	N/A	N/A
	1322-1507								
	SUBTOTAL	0.67		31.95					
Apitron	1648-1830	0.095	0.48	29.85	0.112	30.54	N/A	N/A	N/A
	SUBTOTAL	0.58		29.96					
<b>DATA AVERAGE</b>									
Combustor	Total ppm <sub>dv</sub>		29.97		26.94	56.91	27.9	3.71	31.61
	% wt fraction		52.66%		47.34%	100%	88.26%	11.74%	100%
Apitron	Total ppm <sub>dv</sub>		0.63		28.45	29.08	N/A	N/A	N/A
	% wt fraction		2.17%		97.83%	100%			
	Reduction across Cyclone & Apitron		97.90%		increase	48.90%	N/A	N/A	N/A

- (1) Data from U.S. EPA Method 5/B train. NH<sub>3</sub> was only determined on isopropyl alcohol solution and therefore only a backhalf number.  
 (2) Data by difference from total and backhalf NH<sub>3</sub>.  
 (3) Data from acid gas train.