

STATE OF FLORIDA

DEPARTMENT OF ENVIRONMENTAL REGULATION

TWIN TOWERS OFFICE BUILDING
2600 BLAIR STONE ROAD
TALLAHASSEE, FLORIDA 32301-8241

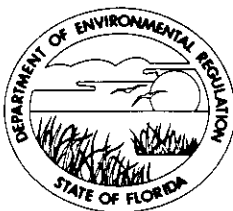

BOB GRAHAM
GOVERNOR

VICTORIA J. TSCHINKEL
SECRETARY

February 4, 1985

CERTIFIED MAIL-RETURN RECEIPT REQUESTED

Mr. J.J. Lewis, Plant Manager
AMAX Chemical Corporation
P.O. Box 790
Plant City, Florida 33566

Dear Mr. Lewis:

Attached is one copy of the Technical Evaluation and Preliminary Determination, and proposed permit to install a dust collector on the transfer point of the two covered belt conveyors that transfer the animal feed supplement from the CDP product storage bins to the bulk railcar loading system.

Before final action can be taken on your draft permit, you are required by Florida Administrative Code Rule 17-103.150 to publish the attached Notice of Proposed Agency Action in the legal advertising section of a newspaper of general circulation in Hillsborough County no later than fourteen days after receipt of this letter. The department must be provided with proof of publication within seven days of the date the notice is published. Failure to publish the notice may be grounds for denial of the permit.

Please submit, in writing, any comments which you wish to have considered concerning the department's proposed action to Mr. Bill Thomas of the Bureau of Air Quality Management.

Sincerely,

CH Fancy
C. H. Fancy, P.E.
Deputy Chief
Bureau of Air Quality
Management

CHF/rw
Attachments
cc: Bill Thomas, SW District
Steve Gyorog, HCEPC
George Townsend, AMAX

No. 0158653
 RECEIPT FOR CERTIFIED MAIL
 NO INSURANCE COVERAGE PROVIDED—
 NOT FOR INTERNATIONAL MAIL
 (See Reverse)

SENT TO		Mr. J. J. Lewis	
STREET AND NO.			
P.O., STATE AND ZIP CODE			
POSTAGE		\$	
CONSULT POSTMASTER FOR FEES	CERTIFIED FEE	¢	
	SPECIAL DELIVERY	¢	
	RESTRICTED DELIVERY	¢	
	OPTIONAL SERVICES RETURN RECEIPT SERVICE	SHOW TO WHOM AND DATE DELIVERED	¢
		SHOW TO WHOM, DATE, AND ADDRESS OF DELIVERY	¢
SHOW TO WHOM AND DATE DELIVERED WITH RESTRICTED DELIVERY		¢	
	SHOW TO WHOM, DATE AND ADDRESS OF DELIVERY WITH RESTRICTED DELIVERY	¢	
TOTAL POSTAGE AND FEES		\$	
POSTMARK OR DATE		2/11/85	

PS Form 3800, Apr. 1976

PS Form 3811, July 1983

● **SENDER: Complete items 1, 2, 3 and 4.**

Put your address in the "RETURN TO" space on the reverse side. Failure to do this will prevent this card from being returned to you. The return receipt fee will provide you the name of the person delivered to and the date of delivery. For additional fees the following services are available. Consult postmaster for fees and check box(es) for service(s) requested.

1. Show to whom, date and address of delivery.
 2. Restricted Delivery.

3. Article Addressed to:
 Mr. J. J. Lewis
 AMAX Chemical Corporation
 P. O. Box 790
 Plant City, Florida 33566

4. Type of Service:	Article Number
<input type="checkbox"/> Registered <input type="checkbox"/> Insured <input checked="" type="checkbox"/> Certified <input type="checkbox"/> COD <input type="checkbox"/> Express Mail	0158653

Always obtain signature of addressee or agent and **DATE DELIVERED.**

5. Signature - Addressee
 X *[Signature]*

6. Signature - Agent
 X

7. Date of Delivery
 2-13-85

8. Addressee's Address (ONLY if requested and fee paid)

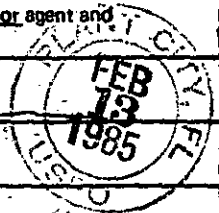

DOMESTIC RETURN RECEIPT

State of Florida
Department of Environmental Regulation
Notice of Proposed Agency Action
on Permit Application

The Department of Environmental Regulation gives notice of its intent to issue a permit to construct a dust collector at the transfer point of the two covered animal feed supplement conveyors at AMAX Chemical Corporation's plant in Plant City, Hillsborough County, Florida. A determination of best available control technology (BACT) was not required. This source will not have a significant impact on the ambient air quality.

Persons whose substantial interests are affected by the Department's proposed permitting decision may petition for an administrative proceeding (hearing) in accordance with Section 120.57, Florida Statutes. The petition must conform to the requirements of Chapters 17-103 and 28-5, Florida Administrative Code, and must be filed (received) in the Office of General Counsel of the Department at 2600 Blair Stone Road, Twin Towers Office Building, Tallahassee, Florida 32301, within fourteen (14) days of publication of this notice. Failure to file a request for hearing within this time period shall constitute a waiver of any right such person may have to request an administrative determination (hearing) under Section 120.57, Florida Statutes.

If a petition is filed, the administrative hearing process is designed to formulate agency action. Accordingly, the Department's final action may be different from the position taken by it in this preliminary statement. Therefore, persons who may not object to the proposed agency action may wish to intervene in the proceeding. A petition for intervention must be filed pursuant to Model Rule 28-5.207 at least five (5) days before the final hearing and be filed with the hearing officer if one has been assigned at the Division of Administrative Hearings, Department of Administration, 2009, Apalachee Parkway, Tallahassee, Florida 32301. If no hearing officer has been assigned, the petition is to be filed with the Department's Office of General Counsel, 2600 Blair Stone Road, Tallahassee, Florida 32301. Failure to petition to intervene within the allowed time frame constitutes a waiver of any right such person has to request a hearing under Section 120.57, Florida Statutes.

The application is available for public inspection during normal business hours, 8:00 a.m. to 5:00 p.m., Monday through Friday, except legal holidays, at:

Department of Environmental Regulation
Southwest District
7601 Highway 301 N.
Tampa, Florida 33610

Hillsborough County Environmental Protection Commission
1900 9th Avenue
Tampa, Florida 33605

Dept. of Environmental Regulation
Bureau of Air Quality Management
2600 Blair Stone Road
Tallahassee, Florida 32301

Any person may send written comments on the proposed action to Mr. Bill Thomas at the department's Tallahassee address. All comments mailed within 30 days of the publication of this notice will be considered in the department's final determination.

RULES OF THE ADMINISTRATIVE COMMISSION
MODEL RULES OF PROCEDURE
CHAPTER 28-5
DECISIONS DETERMINING SUBSTANTIAL INTERESTS

28-5.15 Requests for Formal and Informal Proceedings

- (1) Requests for proceedings shall be made by petition to the agency involved. Each petition shall be printed typewritten or otherwise duplicated in legible form on white paper of standard legal size. Unless printed, the impression shall be on one side of the paper only and lines shall be double spaced and indented.
- (2) All petitions filed under these rules should contain:
 - (a) The name and address of each agency affected and each agency's file or identification number, if known;
 - (b) The name and address of the petitioner or petitioners;
 - (c) All disputed issues of material fact. If there are none, the petition must so indicate;
 - (d) A concise statement of the ultimate facts alleged, and the rules, regulations and constitutional provisions which entitle the petitioner to relief;
 - (e) A statement summarizing any informal action taken to resolve the issues, and the results of that action;
 - (f) A demand for the relief to which the petitioner deems himself entitled; and
 - (g) Such other information which the petitioner contends is material.

BEFORE THE STATE OF FLORIDA
DEPARTMENT OF ENVIRONMENTAL REGULATION

In the Matter of an)
Application for Permit by)
)
AMAX Chemical Corporation) DER File No. AC 29-091317
P.O. Box 790)
Plant City, Florida 33566)
)
)

INTENT TO ISSUE

The Department of Environmental Regulation hereby gives notice of its Intent to Issue, and proposed order of issuance for, a permit pursuant to Chapter 403, Florida Statutes, for the proposed project as detailed in the application specified above. The Department is issuing this Intent to Issue for the reasons stated in the attached Technical Evaluation and Preliminary Determination.

The applicant, AMAX Chemical Corporation, applied on July 23, 1984, to the Department of Environmental Regulation for a permit to construct a dust collector at the transfer point for the two covered animal feed supplement conveyors. The additional information supplied in the letter dated December 18, 1984, (received January 11, 1985) completed the application.

The Department has permitting jurisdiction under Chapter 403, Florida Statutes and Florida Administrative Code Rules 17-2 and 17-4. The project is not exempt from permitting procedures. The applicant was officially notified by the Department that an air construction permit was required for the proposed work.

This intent to issue shall be placed before the Secretary for final action unless an appropriate petition for a hearing pursuant to the provisions of Section 120.57, Florida Statutes, is filed within fourteen (14) days from receipt of this letter or

publication of the public notice (copy attached) required pursuant to Rule 17-103.150, Florida Administrative Code, whichever occurs first. The petition must comply with the requirements of Section 17-103.155 and Rule 28-5.201, Florida Administrative Code (copy attached) and be filed pursuant to Rule 17-103.155(1) in the Office of General Counsel of the Department of Environmental Regulation at 2600 Blair Stone Road, Tallahassee, Florida 32301.

Petitions which are not filed in accordance with the above provisions are subject to dismissal by the Department. In the event a formal hearing is conducted pursuant to Section 120.57(1), all parties shall have opportunity to respond, to present evidence and argument on all issues involved, to conduct cross-examination of witness and submit rebuttal evidence, to submit proposed findings of facts and orders, to file exceptions to any order or hearing officer's recommended order, and to be represented by counsel. If an informal hearing is requested, the agency, in accordance with its rules of procedure, will provide affected persons or parties or their counsel an opportunity, at a convenient time and place, to present to the agency or hearing officer, written or oral evidence in opposition to the agency's action or refusal to act, or a written statement challenging the grounds upon which the agency has chosen to justify its action or inaction, pursuant to Section 120.57(2), Florida Statutes.

If a petition is filed, the administrative hearing process is designed to formulate agency action. Accordingly, the Department's final action may be different from the proposed agency action. Therefore, persons who may not wish to file a petition, may wish to intervene in the proceeding. A petition for intervention must be filed pursuant to Model Rule 28-5.207 at least five (5) days before the final hearing and be filed with the hearing officer if one has been assigned at the Division of

Administrative Hearings, 2009 Apalachee Parkway, Tallahassee, Florida 32301. If no hearing officer has been assigned, the petition is to be filed with the Department's Office of General Counsel, 2600 Blair Stone Road, Tallahassee, Florida 32301. Failure to petition to intervene within the allowed time frame constitutes a waiver of any right such person has to request a hearing under Section 120.57, Florida Statutes.

Executed the 3 day of February, 1985, in Tallahassee, Florida.

STATE OF FLORIDA DEPARTMENT
OF ENVIRONMENTAL REGULATION

(Signature)
C. H. Fancy, P.E.
Deputy Chief
Bureau of Air Quality
Management

Copies furnished to:

J.J. Lewis, AMAX Chemical Corporation
Bill Thomas, SW District
Steve Gyorog, HCEPC

Technical Evaluation
and
Preliminary Determination

AMAX Chemical Corporation
Plant City, Florida
Hillsborough County

Permit Number:
AC 29-091317

Florida Department of Environmental Regulation
Bureau of Air Quality Management
Central Air Permitting
February 1, 1985

I. Applicant and Source Location

A. Applicant

AMAX Chemical Corporation
P.O. Box 790
Plant City, Florida 33566

B. Project and Location

AMAX Chemical Corporation proposes to install a DCE Vokes Model DL - V7 dust collector at the transfer point of two covered belt conveyors that move CDP product (defluorinated animal feed supplement) from the storage area (AO29-66655) to the bulk railcar loading equipment (AO29-66650). The new dust collector will be located at AMAX Chemical Corporation's existing phosphate products plant on Coronet Road in Plant City, Hillsborough County, Florida. The UTM coordinates of this site are 17-393.8 km East and 3096.3 km North.

C. Air Pollution Control Equipment

The dust collector, along with the covers for the two CDP belt conveyors and the dedusting agent added to the CDP product when it leaves the storage area, will control the unconfined particulate emissions from this materials handling operation.

II. Rule Applicability

The proposed project, installation of a dust collector at the transfer point of two covered belt conveyors, is subject to preconstruction review under the provisions of Chapter 403, FS, and Chapter 17-2, FAC.

The proposed facility will be located in an area designated: nonattainment for ozone, (17-2.410[1][f]); unclassifiable for sulfur dioxide (17-2.430[2][c]); and attainment for the other criteria air pollutants (17-2.420). It is in the area of influence (17-2.100[14]) of the Hillsborough County particulate matter nonattainment area (17-2.410[2]).

The existing plant is a major facility for particulate matter because potential emissions of this pollutant exceed 100 TPY. The proposed project is not subject to Prevention of Significant Deterioration regulations (17-2.500) or New Source Review for Nonattainment Area regulations (17-2.510) because its emissions are less than the significant rate listed in Table 500-2 and will have a de minimus ambient impact on the particulate matter nonattainment area (Table 500-3).

The project is subject to review under Rule 17-2.520, FAC, Sources Not Subject to Prevention of Significant Deterioration or Nonattainment Requirements. The emissions from the system must comply with Rule 17-2.610(3), FAC, which requires the use of reasonable precautions to minimize unconfined emissions.

III. Technical Evaluation

Emissions from this proposed project will be the dust generated by the materials handling operation. The air pollution controls proposed by the applicant are a baghouse at the conveyors's transfer point, covers for both conveyors, and the use of a dedusting agent on the CDP product being transferred.

Estimated emissions from the dust collector are 0.02 grains per DSCF. At a flow of 700 SCFM for 16 hours per day, this is equivalent to 0.12 pounds per hour or 0.35 tons per year.

The covered conveyors and dedusting agent will be required to reduce all other discharges from the system to no visible emissions.

IV. Air Quality Impact

The estimated emissions from the proposed project are too low to have a significant impact on the ambient air quality in the vicinity of the plant. Therefore, an ambient air quality impact analysis was not required for the project.

V. CONCLUSION

Based on the information submitted by AMAX Chemical Corporation in their application dated August 6, 1984, and in their letter dated December 18, 1984, the department has concluded that the dust collector can be installed and this material transfer system operated in compliance with all state and local air pollution control regulations. The department proposes to issue a construction permit that will authorize the installation of the dust collector. The General and Specific Conditions listed in the proposed permit (attached) will assure compliance of the source with the air pollution control regulations.

DEPARTMENT OF ENVIRONMENTAL REGULATION

TWIN TOWERS OFFICE BUILDING
2600 BLAIR STONE ROAD
TALLAHASSEE, FLORIDA 32301-8241



BOB GRAHAM
GOVERNOR

VICTORIA J. TSCHINKEL
SECRETARY

PERMITTEE:
AMAX Chemical Corporation
P.O. Box 790
Plant City, Florida 34289

Permit Number: AC29-091317
Expiration Date: November 1, 1985
County: Hillsborough
Latitude/Longitude: 27° 59' 21" N/
82° 04' 48" W

Project: Conveyor Belt Transfer Point
Dust Collector (SSD-25)

This permit is issued under the provisions of Chapter 403, Florida Statutes, and Florida Administrative Code Rule(s) 17-2 and 17-4. The above named permittee is hereby authorized to perform the work or operate the facility shown on the application and approved drawing(s), plans, and other documents attached hereto or on file with the department and made a part hereof and specifically described as follows:

For the construction of a DCE Vokes Model DLM-V7 dust collector, or equivalent baghouse, at the transfer point of the east-west and north-south covered CDP product conveyor belts.

The UTM coordinates of the site are zone 17, 393.8 km East and 3096.3 km North

Construction shall be in accordance with the application for a permit to construct a conveyor belt transfer point dust collector (SSD-25) signed by Mr. J.J. Lewis on August 6, 1984, and the information supplied by Mr. George Townsend in a letter dated December 18, 1984, except for the changes listed in the specific conditions of this permit.

Attachments are as follows:

1. Application, dated August 6, 1984.
2. Letter, dated December 18, 1984.

PERMITTEE:
AMAX Chemical Corporation

Permit Number: AC29-091317
Expiration Date: November 1, 1985

GENERAL CONDITIONS:

1. The terms, conditions, requirements, limitations, and restrictions set forth herein are "Permit Conditions" and as such are binding upon the permittee and enforceable pursuant to the authority of Sections 403.161, 403.727, or 403.859 through 403.861, Florida Statutes. The permittee is hereby placed on notice that the department will review this permit periodically and may initiate enforcement action for any violation of the "Permit Conditions" by the permittee, its agents, employees, servants or representatives.
2. This permit is valid only for the specific processes and operations applied for and indicated in the approved drawings or exhibits. Any unauthorized deviation from the approved drawings, exhibits, specifications, or conditions of this permit may constitute grounds for revocation and enforcement action by the department.
3. As provided in Subsections 403.087(6) and 403.722(5), Florida Statutes, the issuance of this permit does not convey any vested rights or any exclusive privileges. Nor does it authorize any injury to public or private property or any invasion of personal rights, nor any infringement of federal, state or local laws or regulations. This permit does not constitute a waiver of or approval of any other department permit that may be required for other aspects of the total project which are not addressed in the permit.
4. This permit conveys no title to land or water, does not constitute state recognition or acknowledgement of title, and does not constitute authority for the use of submerged lands unless herein provided and the necessary title or leasehold interests have been obtained from the state. Only the Trustees of the Internal Improvement Trust Fund may express state opinion as to title.
5. This permit does not relieve the permittee from liability for harm or injury to human health or welfare, animal, plant or aquatic life or property and penalties therefore caused by the construction or operation of this permitted source, nor does it allow the permittee to cause pollution in contravention of Florida Statutes and department rules, unless specifically authorized by an order from the department.

PERMITTEE:
AMAX Chemical Corporation

Permit Number: AC29-091317
Expiration Date: November 1, 1985

GENERAL CONDITIONS:

6. The permittee shall at all times properly operate and maintain the facility and systems of treatment and control (and related appurtenances) that are installed or used by the permittee to achieve compliance with the conditions of this permit, as required by department rules. This provision includes the operation of backup or auxiliary facilities or similar systems when necessary to achieve compliance with the conditions of the permit and when required by department rules.

7. The permittee, by accepting this permit, specifically agrees to allow authorized department personnel, upon presentation of credentials or other documents as may be required by law, access to the premises, at reasonable times, where the permitted activity is located or conducted for the purpose of:

- a. Having access to and copying any records that must be kept under the conditions of the permit;
- b. Inspecting the facility, equipment, practices, or operations regulated or required under this permit; and
- c. Sampling or monitoring any substances or parameters at any location reasonably necessary to assure compliance with this permit or department rules.

Reasonable time may depend on the nature of the concern being investigated.

8. If, for any reason, the permittee does not comply with or will be unable to comply with any condition or limitation specified in this permit, the permittee shall immediately notify and provide the department with the following information:

- a. a description of and cause of non-compliance; and
- b. the period of noncompliance, including exact dates and times; or, if not corrected, the anticipated time the noncompliance is expected to continue, and steps being taken to reduce, eliminate, and prevent recurrence of the noncompliance.

PERMITTEE:
AMAX Chemical Corporation

Permit Number: AC29-091317
Expiration Date: November 1, 1985

GENERAL CONDITIONS:

The permittee shall be responsible for any and all damages which may result and may be subject to enforcement action by the department for penalties or revocation of this permit.

9. In accepting this permit, the permittee understands and agrees that all records, notes, monitoring data and other information relating to the construction or operation of this permitted source, which are submitted to the department, may be used by the department as evidence in any enforcement case arising under the Florida Statutes or department rules, except where such use is proscribed by Sections 403.73 and 403.111, Florida Statutes.

10. The permittee agrees to comply with changes in department rules and Florida Statutes after a reasonable time for compliance, provided however, the permittee does not waive any other rights granted by Florida Statutes or department rules.

11. This permit is transferable only upon department approval in accordance with Florida Administrative Code Rules 17-4.12 and 17-30.30, as applicable. The permittee shall be liable for any non-compliance of the permitted activity until the transfer is approved by the department.

12. This permit is required to be kept at the work site of the permitted activity during the entire period of construction or operation.

13. This permit also constitutes:

- () Determination of Best Available Control Technology (BACT)
- () Determination of Prevention of Significant Deterioration (PSD).
- () Compliance with New Source Performance Standards.

14. The permittee shall comply with the following monitoring and record keeping requirements:

- a. Upon request, the permittee shall furnish all records and plans required under department rules. The retention period for all records will be extended automatically, unless otherwise stipulated by the department, during the course of any unresolved enforcement action.

PERMITTEE:
AMAX Chemical Corporation

Permit Number: AC29-091317
Expiration Date: November 1, 1985

GENERAL CONDITIONS:

- b. The permittee shall retain at the facility or other location designated by this permit records of all monitoring information (including all calibration and maintenance records and all original strip chart recordings for continuous monitoring instrumentation), copies of all reports required by this permit, and records of all data used to complete the application for this permit. The time period of retention shall be at least three years from the date of the sample, measurement, report or application unless otherwise specified by department rule.
- c. Records of monitoring information shall include:
 - the date, exact place, and time of sampling or measurements;
 - the person responsible for performing the sampling or measurements;
 - the date(s) analyses were performed;
 - the person responsible for performing the analyses;
 - the analytical techniques or methods used; and
 - the results of such analyses.

15. When requested by the department, the permittee shall within a reasonable time furnish any information required by law which is needed to determine compliance with the permit. If the permittee becomes aware that relevant facts were not submitted or were incorrect in the permit application or in any report to the department, such facts or information shall be submitted or corrected promptly.

SPECIFIC CONDITIONS:

1. Not more than 40 TPH of CDP material shall be transferred by the east-west and north-south belt conveyors without prior approval of the Southwest District office.
2. The conveyor belts shall not operate more than 16 hours per day without prior approval of the Southwest District office.
3. Particulate matter emissions from the dust collector at the transfer point shall not exceed 0.02 grains per dry standard cubic foot as determined by EPA reference method No. 5, which is described in 40 CFR 60, Appendix A. If visible emissions from the dust collector are less than 5 percent opacity, the district may waive this compliance test.

PERMITTEE:
AMAX Chemical Corporation

Permit Number: AC29-091317
Expiration Date: November 1, 1985

SPECIFIC CONDITIONS:

4. Visible emissions from any part of this system shall not exceed 5 percent opacity, 6 minute average, as determined by EPA reference Method No. 9, described in 40 CFR 60, Appendix A.
5. The transfer system shall not be operated unless all the covers are on the belt conveyors and an adequate amount of dedusting agent is being added to keep the visible emissions from exceeding 5 percent opacity.
6. The applicant shall submit a complete application for a permit to operate the conveyor belt transfer point dust collector (SSD-25), which will include an emission test report, to the Hillsborough County Environmental Protection Commission at least 90 days prior to the expiration date of this construction permit. The company may continue to operate this material transfer system if the emissions are in compliance with the permit conditions.
7. Upon obtaining a permit to operate, the company will be required to submit annual operation reports to the Hillsborough County Environmental Protection Commission.

Issued this _____ day of _____,
19__.

STATE OF FLORIDA DEPARTMENT
OF ENVIRONMENTAL REGULATION

VICTORIA J. TSCHINKEL, Secretary

____ pages attached.

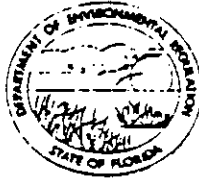

D. E. R.

STATE OF FLORIDA
 DEPARTMENT OF ENVIRONMENTAL REGULATION
 APPLICATION TO OPERATE/CONSTRUCT
 AIR POLLUTION SOURCES

AUG 10 1984

1ST DISTRICT
 TAMPA

SOURCE TYPE: Point Source Air Pollution New¹ [] Existing¹
 APPLICATION TYPE: Construction [] Operation [] Modification
 COMPANY NAME: Amax Phosphate, Inc. COUNTY: Hillsborough
 Identify the specific emission point source(s) addressed in this application (i.e. Lime Kiln No. 4 with Venturi Scrubber; Peeking Unit No. 2, Gas Fired) Conveyor Belt Transfer Point Dust Collector (SSD-25)
 SOURCE LOCATION: Street Coronet Road City Plant City
 UTM: East 17-393.8 North 3096.3
 Latitude ° ' "N Longitude ° ' "W
 APPLICANT NAME AND TITLE: J. J. Lewis, Plant Manager
 APPLICANT ADDRESS: P.O. Box 790, Plant City, Florida 33566

SECTION I: STATEMENTS BY APPLICANT AND ENGINEER

A. APPLICANT

I am the undersigned owner or authorized representative* of Amax Phosphate, Inc.

I certify that the statements made in this application for a construction permit are true, correct and complete to the best of my knowledge and belief. Further, I agree to maintain and operate the pollution control source and pollution control facilities in such a manner as to comply with the provision of Chapter 403, Florida Statutes, and all the rules and regulations of the department and revisions thereof. I also understand that a permit, if granted by the department, will be non-transferable and I will promptly notify the department upon sale or legal transfer of the permitted establishment.

*Attach letter of authorization

Signed: J. J. Lewis
J. J. Lewis, Plant Manager
 Name and Title (Please Type)
 Date: 8/6/84 Telephone No. (813) 752-1161

B. PROFESSIONAL ENGINEER REGISTERED IN FLORIDA (where required by Chapter 471, F.S.)

This is to certify that the engineering features of this pollution control project have been designed/examined by me and found to be in conformity with modern engineering principles applicable to the treatment and disposal of pollutants characterized in the permit application. There is reasonable assurance, in my professional judgment, that the pollution control facilities, when properly maintained and operated, will discharge an effluent that complies with all applicable statutes of the State of Florida and the rules and regulations of the department. It is also agreed that the undersigned will furnish, if authorized by the owner, the applicant a set of instructions for the proper maintenance and operation of the pollution control facilities and, if applicable, pollution sources.

Signed: Anthony R. Lenkei
Anthony R. Lenkei
 Name (Please Type)
Amax Phosphate, Inc.
 Company Name (Please Type)
P.O. Box 790, Plant City, Florida 33566
 Mailing Address (Please Type)
 Florida Registration No. 8716 Date: 8, 2, 84 Telephone No. (813) 752-1161

(Affix Seal)

¹See Section 17-2.02(15) and (22), Florida Administrative Code, (F.A.C.)

SECTION II: GENERAL PROJECT INFORMATION

A. Describe the nature and extent of the project. Refer to pollution control equipment, and expected improvements in source performance as a result of installation. State whether the project will result in full compliance. Attach additional sheet if necessary.

A DCE Vokes model DLM-V7# dust collector will be installed at the transfer point of the east-west, north-south CDP product conveyor belt.

B. Schedule of project covered in this application (Construction Permit Application Only)

Start of Construction September 1, 1984 Completion of Construction December 1, 1984

C. Costs of pollution control system(s): (Note: Show breakdown of estimated costs only for individual components/units of the project serving pollution control purposes. Information on actual costs shall be furnished with the application for operation permit.)

Dust collector ----\$2,091

Installation -----\$2,072 mechanical, electrical, air line Ø 3/4"

D. Indicate any previous DER permits, orders and notices associated with the emission point, including permit issuance and expiration dates.

Not Applicable

E. Is this application associated with or part of a Development of Regional Impact (DRI) pursuant to Chapter 380, Florida Statutes, and Chapter 22F-2, Florida Administrative Code? Yes XX No

F. Normal equipment operating time: hrs/day 16 ; days/wk 7 ; wks/yr 52 ; if power plant, hrs/yr N/A ; if seasonal, describe: _____

G. If this is a new source or major modification, answer the following questions. (Yes or No)

- | | |
|---|----------------|
| 1. Is this source in a non-attainment area for a particular pollutant? | <u> Yes </u> |
| a. If yes, has "offset" been applied? | <u> N/A </u> |
| b. If yes, has "Lowest Achievable Emission Rate" been applied? | <u> N/A </u> |
| c. If yes, list non-attainment pollutants. | |
| <u>VOC and Ozone</u> | |
| 2. Does best available control technology (BACT) apply to this source? If yes, see Section VI. | <u> No </u> |
| 3. Does the State "Prevention of Significant Deterioration" (PSD) requirements apply to this source? If yes, see Sections VI and VII. | <u> No </u> |
| 4. Do "Standards of Performance for New Stationary Sources" (NSPS) apply to this source? | <u> No </u> |
| 5. Do "National Emission Standards for Hazardous Air Pollutants" (NESHAP) apply to this source? | <u> No </u> |

Attach all supportive information related to any answer of "Yes". Attach any justification for any answer of "No" that might be considered questionable.

SECTION III: AIR POLLUTION SOURCES & CONTROL DEVICES (Other than Incinerators)

A. Raw Materials and Chemicals Used in your Process, if applicable:

Description	Contaminants		Utilization Rate - lbs/hr	Relate to Flow Diagram
	Type	% Wt		
CDP(defluorinated)	Particulate	10%	80,000	See Attachment E
Animal Feed				
Supplement				

B. Process Rate, if applicable: (See Section V, Item 1)

- Total Process Input Rate (lbs/hr): N/A (Product Transfer)
- Product Weight (lbs/hr): 80,000 lbs/hr

C. Airborne Contaminants Emitted:

Name of Contaminant	Emission ¹		Allowed Emission ² Rate per Ch. 17-2, F.A.C.	Allowable ³ Emission lbs/hr	Potential Emission ⁴		Relate to Flow Diagram
	Maximum lbs/hr	Actual T/yr			lbs/hr	T/yr	
Particulate	0.12	0.35	*see below	0.12	34.32	100	See attachment E

D. Control Devices: (See Section V, Item 4)

Name and Type (Model & Serial No.)	Contaminant	Efficiency	Range of Particles ⁵ Size Collected (in microns)	Basis for Efficiency (Sec. V, It ⁵)
DLM - V7,F	Particulate	99+%	N/A	manufacturer's specification

¹See Section V, Item 2.

²Reference applicable emission standards and units (e.g., Section 17-2.05(6) Table II, E. (1), F.A.C. – 0.1 pounds per million BTU heat input)

³Calculated from operating rate and applicable standard

⁴Emission, if source operated without control (See Section V, Item 3) Commission.

⁵If Applicable

E. Fuels

Not Applicable

Type (Be Specific)	Consumption*		Maximum Heat Input (MMBTU/hr)
	avg/hr	max./hr	

*Units Natural Gas, MMCF/hr; Fuel Oils, barrels/hr; Coal, lbs/hr Not Applicable

Fuel Analysis:

Percent Sulfur: _____ Percent Ash: _____

Density: _____ lbs/gal Typical Percent Nitrogen: _____

Heat Capacity: _____ BTU/lb _____ BTU/gal

Other Fuel Contaminants (which may cause air pollution): _____

F. If applicable, indicate the percent of fuel used for space heating. Annual Average _____ Maximum _____

G. Indicate liquid or solid wastes generated and method of disposal.

Collected material is returned to conveyor belt for input into storage bin.

H. Emission Stack Geometry and Flow Characteristics (Provide data for each stack):

Stack Height: 70 ft Stack Diameter: 7.36" (equivalent dia.) ft

Gas Flow Rate: 700 ACFM Gas Exit Temperature: Ambient °F.

Water Vapor Content: N/A % Velocity: 19.02 FPS

SECTION IV: INCINERATOR INFORMATION

Not Applicable

Type of Waste	Type O (Plastics)	Type I (Rubbish)	Type II (Refuse)	Type III (Garbage)	Type IV (Pathological)	Type V (Liq & Gas By-prod.)	Type VI (Solid By-prod.)
Lbs/hr Incinerated							

Description of Waste _____

Total Weight Incinerated (lbs/hr) _____ Design Capacity (lbs/hr) _____

Approximate Number of Hours of Operation per day _____ days/week _____

Manufacturer _____

Date Constructed _____ Model No. _____

	Volume (ft) ³	Heat Release (BTU/hr)	Fuel		Temperature (°F)
			Type	BTU/hr	
Primary Chamber					
Secondary Chamber					

Stack Height: _____ ft. Stack Diameter _____ Stack Temp. _____

Gas Flow Rate: _____ ACFM _____ DSCFM* Velocity _____ FPS

*If 50 or more tons per day design capacity, submit the emissions rate in grains per standard cubic foot dry gas corrected to 50% excess air.

Type of pollution control device: [] Cyclone [] Wet Scrubber [] Afterburner [] Other (specify) _____

Brief description of operating characteristics of control devices: _____

Ultimate disposal of any effluent other than that emitted from the stack (scrubber water, ash, etc.):

SECTION V: SUPPLEMENTAL REQUIREMENTS

Please provide the following supplements where required for this application.

1. Total process input rate and product weight — show derivation. See Attachment A
2. To a construction application, attach basis of emission estimate (e.g., design calculations, design drawings, pertinent manufacturer's test data, etc.) and attach proposed methods (e.g., FR Part 60 Methods 1, 2, 3, 4, 5) to show proof of compliance with applicable standards. To an operation application, attach test results or methods used to show proof of compliance. Information provided when applying for an operation permit from a construction permit shall be indicative of the time at which the test was made. See Attachment B
3. Attach basis of potential discharge (e.g., emission factor, that is, AP42 test). See Attachment B
4. With construction permit application, include design details for all air pollution control systems (e.g., for baghouse include cloth to air ratio; for scrubber include cross-section sketch, etc.). See Attachment C-1, C-2, & C-3
5. With construction permit application, attach derivation of control device(s) efficiency. Include test or design data. Items 2, 3, and 5 should be consistent: actual emissions = potential (1-efficiency). See Attachment B
6. An 8½" x 11" flow diagram which will, without revealing trade secrets, identify the individual operations and/or processes. Indicate where raw materials enter, where solid and liquid waste exit, where gaseous emissions and/or airborne particles are evolved and where finished products are obtained. See Attachment D-1 & D-2
7. An 8½" x 11" plot plan showing the location of the establishment, and points of airborne emissions, in relation to the surrounding area, residences and other permanent structures and roadways (Example: Copy of relevant portion of USGS topographic map). See Attachment E
8. An 8½" x 11" plot plan of facility showing the location of manufacturing processes and outlets for airborne emissions. Relate all flows to the flow diagram. See Attachment E

- 9. An application fee of \$20, unless exempted by Section 17-4.05(3), F.A.C. The check should be made payable to the Department of Environmental Regulation.
- 10. With an application for operation permit, attach a Certificate of Completion of Construction indicating that the source was constructed as shown in the construction permit.

Not Applicable

SECTION VI: BEST AVAILABLE CONTROL TECHNOLOGY

- A. Are standards of performance for new stationary sources pursuant to 40 C.F.R. Part 60 applicable to the source?
 Yes No

Contaminant	Rate or Concentration
_____	_____
_____	_____
_____	_____
_____	_____

- B. Has EPA declared the best available control technology for this class of sources (If yes, attach copy) Yes No

Contaminant	Rate or Concentration
_____	_____
_____	_____
_____	_____
_____	_____

- C. What emission levels do you propose as best available control technology?

Contaminant	Rate or Concentration
_____	_____
_____	_____
_____	_____
_____	_____

- D. Describe the existing control and treatment technology (if any).

- | | |
|---------------------------|----------------------|
| 1. Control Device/System: | 4. Capital Costs: |
| 2. Operating Principles: | 5. Operating Costs: |
| 3. Efficiency: * | 6. Maintenance Cost: |
| 7. Useful Life: | |
| 8. Energy: | |
| 9. Emissions: | |

Contaminant	Rate or Concentration
_____	_____
_____	_____
_____	_____
_____	_____

*Explain method of determining D 3 above.

10. Stack Parameters

- | | | | |
|---------------|------|-----------------|-----|
| a. Height: | ft. | b. Diameter: | ft. |
| c. Flow Rate: | ACFM | d. Temperature: | °F |
| e. Velocity: | FPS | | |

E. Describe the control and treatment technology available (As many types as applicable, use additional pages if necessary).

1.

- a. Control Device:
- b. Operating Principles:

- c. Efficiency*:
- d. Capital Cost:
- e. Useful Life:
- f. Operating Cost:
- g. Energy*:
- h. Maintenance Cost:
- i. Availability of construction materials and process chemicals:

- j. Applicability to manufacturing processes:
- k. Ability to construct with control device, install in available space, and operate within proposed levels:

2.

- a. Control Device:
- b. Operating Principles:

- c. Efficiency*:
- d. Capital Cost:
- e. Useful Life:
- f. Operating Cost:
- g. Energy**:
- h. Maintenance Costs:
- i. Availability of construction materials and process chemicals:

- j. Applicability to manufacturing processes:
- k. Ability to construct with control device, install in available space, and operate within proposed levels:

*Explain method of determining efficiency.

**Energy to be reported in units of electrical power – KWH design rate.

3.

- a. Control Device:
- b. Operating Principles:

- c. Efficiency*:
- d. Capital Cost:
- e. Life:
- f. Operating Cost:
- g. Energy:
- h. Maintenance Cost:

*Explain method of determining efficiency above.

- i. Availability of construction materials and process chemicals:
 - j. Applicability to manufacturing processes:
 - k. Ability to construct with control device, install in available space and operate within proposed levels:
- 4.
- a. Control Device
 - b. Operating Principles:
 - c. Efficiency *:
 - d. Capital Cost:
 - e. Life:
 - f. Operating Cost:
 - g. Energy:
 - h. Maintenance Cost:
 - i. Availability of construction materials and process chemicals:
 - j. Applicability to manufacturing processes:
 - k. Ability to construct with control device, install in available space, and operate within proposed levels:

F. Describe the control technology selected:

- 1. Control Device:
- 2. Efficiency *:
- 3. Capital Cost:
- 4. Life:
- 5. Operating Cost:
- 6. Energy:
- 7. Maintenance Cost:
- 8. Manufacturer:
- 9. Other locations where employed on similar processes:
 - a.
 - (1) Company:
 - (2) Mailing Address:
 - (3) City:
 - (4) State:
 - (5) Environmental Manager:
 - (6) Telephone No.:

*Explain method of determining efficiency above.

(7) Emissions*:

Contaminant	Rate or Concentration
_____	_____
_____	_____
_____	_____

- (8) Process Rate*:
- b.
 - (1) Company:
 - (2) Mailing Address:
 - (3) City:
 - (4) State:

*Applicant must provide this information when available. Should this information not be available, applicant must state the reason(s) why.

(5) Environmental Manager:

(6) Telephone No.:

(7) Emissions*:

Contaminant	Rate or Concentration
_____	_____
_____	_____
_____	_____

(8) Process Rate*:

10. Reason for selection and description of systems:

*Applicant must provide this information when available. Should this information not be available, applicant must state the reason(s) why.

SECTION VII - PREVENTION OF SIGNIFICANT DETERIORATION

A. Company Monitored Data

1. _____ no sites _____ TSP _____ () SO2* _____ Wind spd/dir
Period of monitoring _____ / _____ / _____ to _____ / _____ / _____
month day year month day year

Other data recorded _____

Attach all data or statistical summaries to this application.

2. Instrumentation, Field and Laboratory

a) Was instrumentation EPA referenced or its equivalent? _____ Yes _____ No

b) Was instrumentation calibrated in accordance with Department procedures? _____ Yes _____ No _____ Unknown

B. Meteorological Data Used for Air Quality Modeling

1. _____ Year(s) of data from _____ / _____ / _____ to _____ / _____ / _____
month day year month day year

2. Surface data obtained from (location) _____

3. Upper air (mixing height) data obtained from (location) _____

4. Stability wind rose (STAR) data obtained from (location) _____

C. Computer Models Used

- 1. _____ Modified? If yes, attach description.
2. _____ Modified? If yes, attach description.
3. _____ Modified? If yes, attach description.
4. _____ Modified? If yes, attach description.

Attach copies of all final model runs showing input data, receptor locations, and principle output tables.

D. Applicants Maximum Allowable Emission Data

Table with 2 columns: Pollutant, Emission Rate. Rows for TSP and SO2 with blank lines for values and units (grams/sec).

E. Emission Data Used in Modeling

Attach list of emission sources. Emission data required is source name, description on point source (on NEDS point number), UTM coordinates, stack data, allowable emissions, and normal operating time.

F. Attach all other information supportive to the PSD review.

*Specify bubbler (B) or continuous (C).

G. Discuss the social and economic impact of the selected technology versus other applicable technologies (i.e., jobs, payroll, production, taxes, energy, etc.). Include assessment of the environmental impact of the sources.

H. Attach scientific, engineering, and technical material, reports, publications, journals, and other competent relevant information describing the theory and application of the requested best available control technology.

ATTACHMENT A

Transfer Rate

80,000 Lbs./Hr. CDP (Coronet Defluorinated Phosphate)

Transferred to Storage Bin

80,000 Lbs./Hr. CDP

Note: Collected material is returned to the conveyor belt.

ATTACHMENT B

Particulate Emission Estimate

Estimated Dust Collector Loading = 5.72 Grains/Ft.³

100% - 99.65% (Dust Collector Efficiency) = 0.35%

5.72 Grains/Ft.³ x 700 SCFM Air Flow =

4,004 Grains/Min x 60 Min/Hour =

240,240 Grains/Hour ÷ 7,000 Grains/Lb. =

34.32 Lbs./Hour Loading x 0.35% =

0.12 Lbs./Hour Emissions

0.12 Lbs./Hour Emissions x 5,824 Hours Annual Operating Time =

699 Lbs./Year Emissions ÷ 2,000 Lbs./Ton =

0.35 Tons/Year Emissions

Potential Emissions

34.32 Lbs./Hour Dust Collector Loading

34.32 Lbs./Hour x 5,824 Hours Annual Operating Time =

199,880 Lbs./Year ÷ 2,000 Lbs./Ton =

100 Tons/Year Potential Emissions

EPA Method 9 shall be used to demonstrate compliance.

ATTACHMENT C-1

The DCE Vokes DLM-V Type F, Dalmatic is a reverse jet fabric filter collector with integral fan.

Collector Specification:

Model -----DLM V7F
Filter Area -----70 Sq. Ft.
No. of Elements -----10
Air Volume -----700 CFM
Air-to-Cloth Ratio -----10 to 1
Compressed Air Required -----5.1 CFM @ 90 PSI G
Fan Size -----2 HP
Approximate Weight -----620 Lbs.

Generally baghouses are considered to be 99+% efficient in applications such as this one. This unit will meet or exceed this level.

Series DLM-V

ATTACHMENT C-2

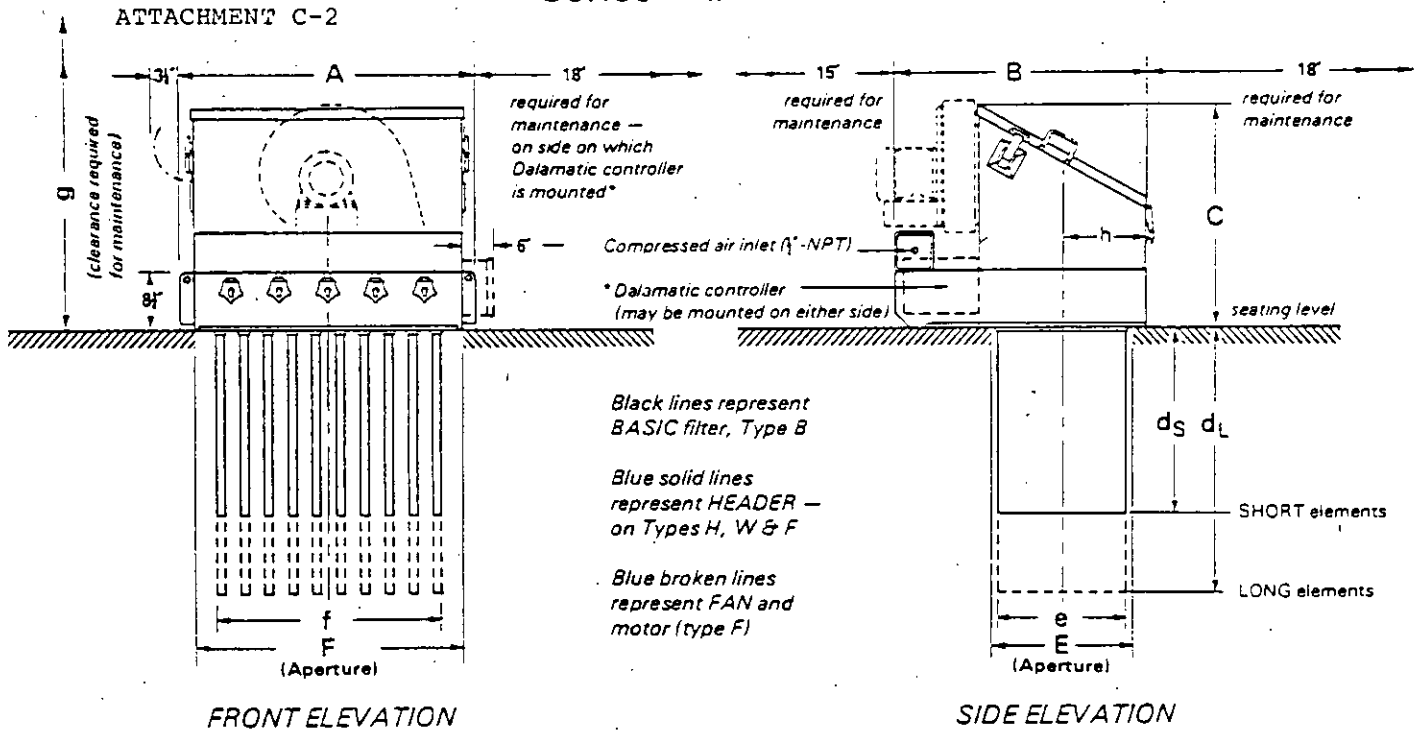

Size DLM-V7 illustrated, larger elements representing DLM-V10

MODEL*	DIMENSIONS (Tolerance = $\pm \frac{1}{8}$ " on main dimensions)													
	A	d _s	d _L	All Types					Type B			Types H, W & F†		
				E	e	F	f	h	B	C	g	B‡	C‡	g
DLM-V4	2' 3 1/2"	2' 3 1/2"	-	20 1/2"	19"	23 1/2"	18 1/2"	12 1/2"	2' 11 1/2"	14 1/2"	2' 10"	2' 11 1/2"	2' 6 3/8"	3' 7"
DLM-V6	2' 3 1/2"	-	3' 3 1/2"	20 1/2"	19"	23 1/2"	18 1/2"	12 1/2"	2' 11 1/2"	14 1/2"	4' 0"	2' 11 1/2"	2' 6 3/8"	4' 11"
DLM-V7	3' 7 1/2"	2' 3 1/2"	-	20 1/2"	19"	3' 3 1/2"	2' 8 1/2"	12 1/2"	3' 0 3/8"	14 1/2"	2' 10"	3' 0 3/8"	2' 8 3/8"	3' 7"
DLM-V10	3' 7 1/2"	-	3' 3 1/2"	20 1/2"	19"	3' 3 1/2"	2' 8 1/2"	12 1/2"	3' 0 3/8"	14 1/2"	4' 0"	3' 0 3/8"	2' 8 3/8"	4' 11"
DLM-V12	2' 3 1/2"	-	3' 3 1/2"	3' 5 1/2"	3' 3 1/2"	23 1/2"	18 1/2"	22 3/8"	5' 0"	15 1/2"	4' 0"	5' 0"	2' 10"	4' 11"
DLM-V14	3' 7 1/2"	2' 3 1/2"	-	3' 5 1/2"	3' 3 1/2"	3' 3 1/2"	2' 8 1/2"	22 3/8"	5' 0"	15 1/2"	2' 10"	5' 0"	2' 10"	3' 7"
DLM-V20	3' 7 1/2"	-	3' 3 1/2"	3' 5 1/2"	3' 3 1/2"	3' 3 1/2"	2' 8 1/2"	22 3/8"	5' 0"	15 1/2"	4' 0"	5' 0"	2' 10"	4' 11"

*For number of elements and total filter areas see chart on page 8 †For fan details see below
‡Type F fan motors and cases may project by up to 2 1/2" beyond these dimensions

MODEL	APPROX. NET WEIGHTS			
	Type B	Type H	Type W	Type F
DLM-V4	220 lb	270 lb	280 lb	320 lb
DLM-V6	250 lb	300 lb	310 lb	350 lb
DLM-V7	490 lb	540 lb	560 lb	620 lb
DLM-V10	540 lb	600 lb	620 lb	670 lb
DLM-V12	510 lb	560 lb	580 lb	660 lb
DLM-V14	620 lb	740 lb	760 lb	850 lb
DLM-V20	710 lb	830 lb	850 lb	960 lb

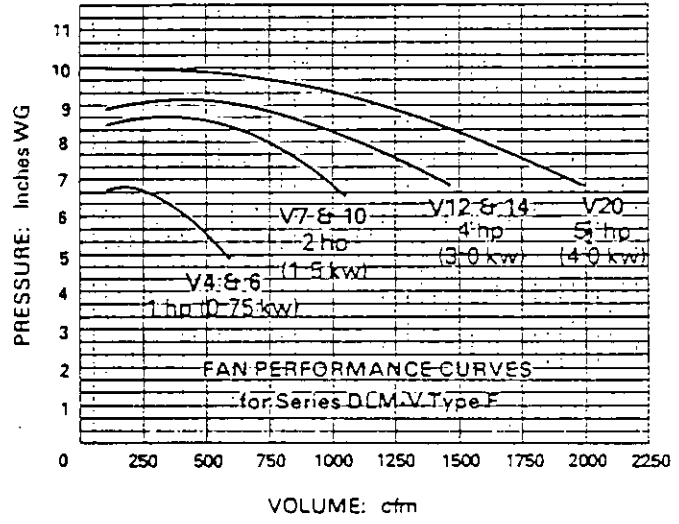

OPERATING DESIGN LIMITS

Temperature range: Types B, H & W Two choices available: (a) 15° to 140°F, (b) 15° to 250°F; Type F 15° to 140°F
For lower or higher temperature applications consult with DCE VOKES Inc.
Pressure limits for Type H: -15" to +2" WG.

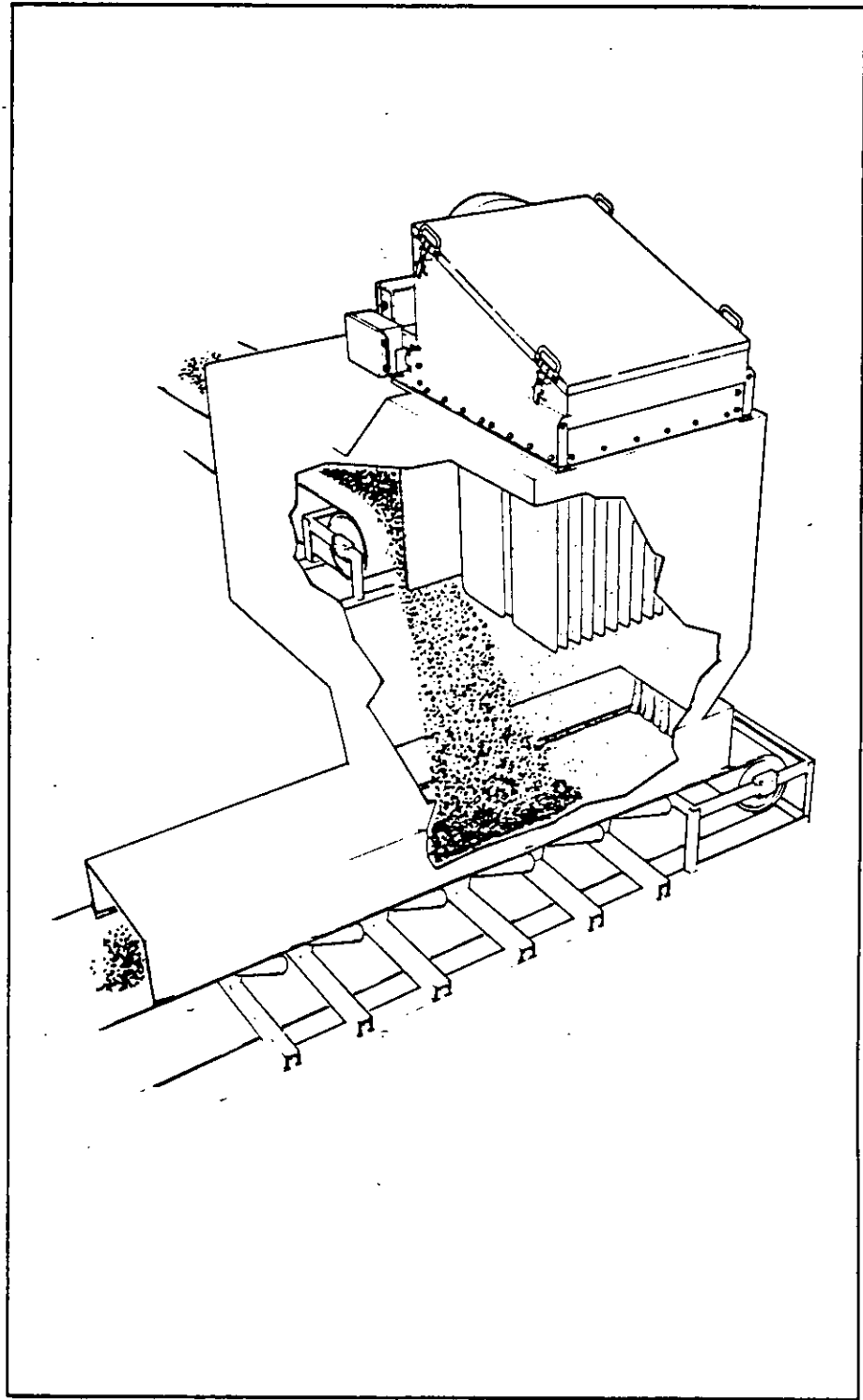

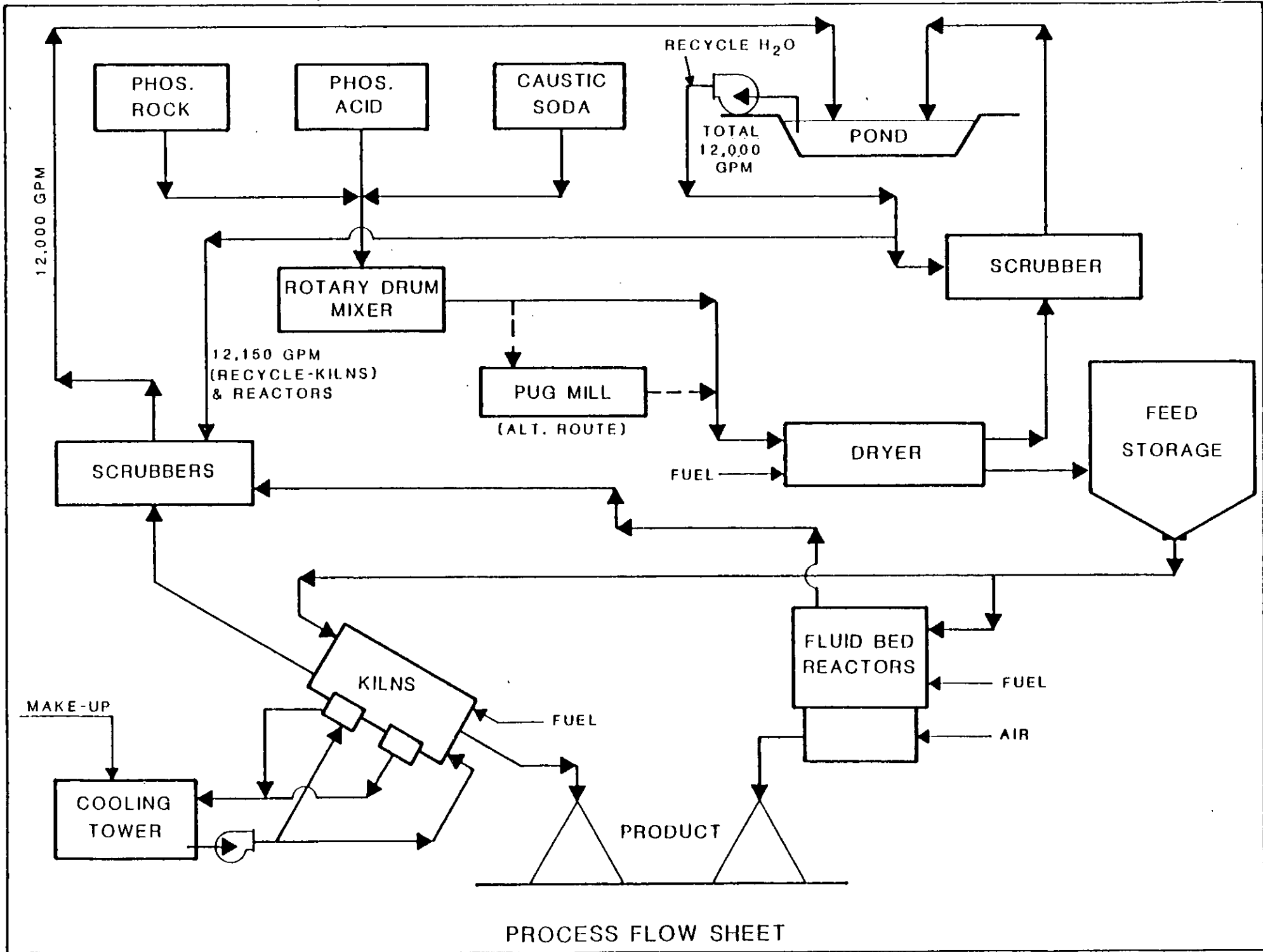

PROCESS FLOW SHEET

AMAX PLANT CITY OPERATION

ATTACHMENT D-2

FLOW DIAGRAM

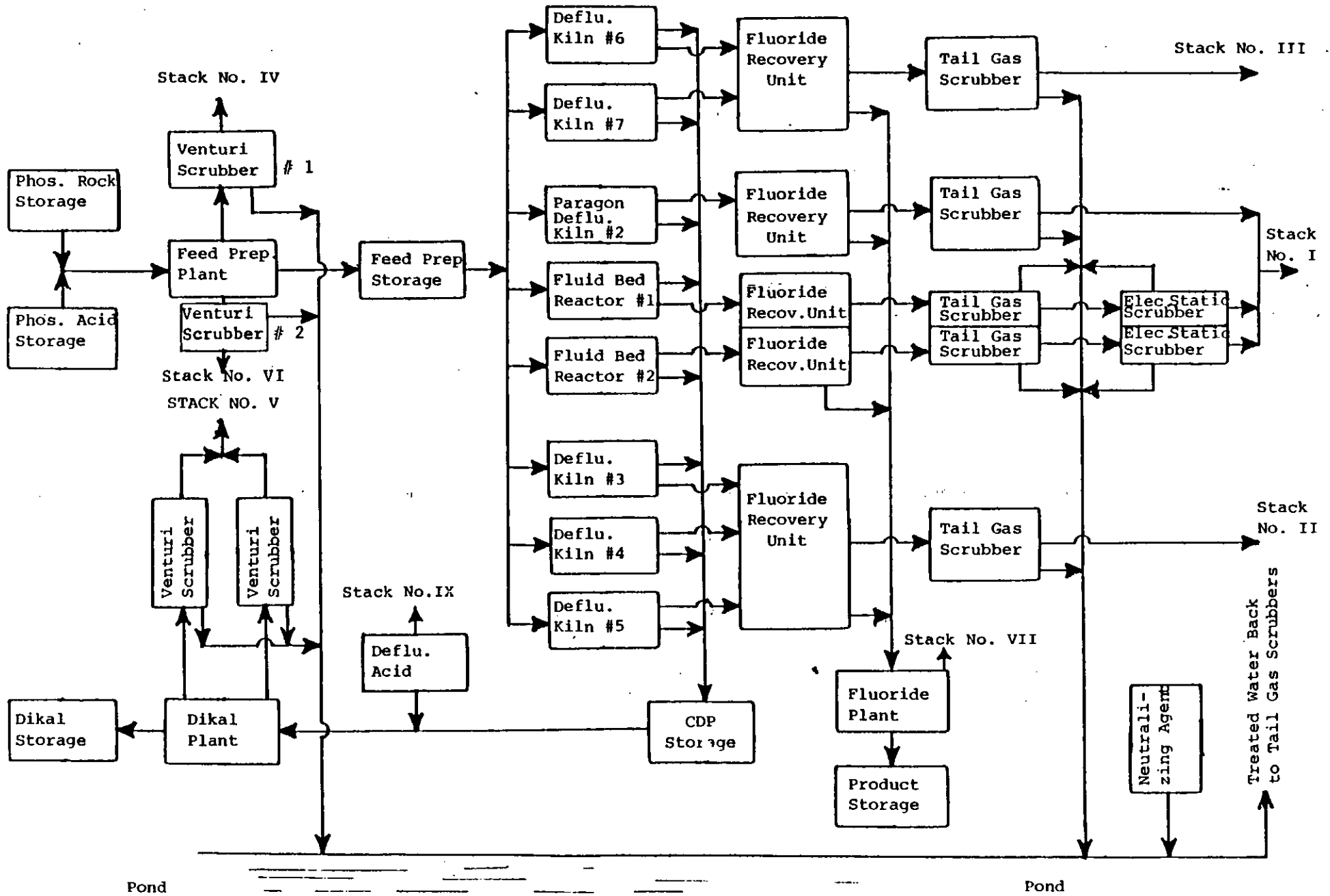

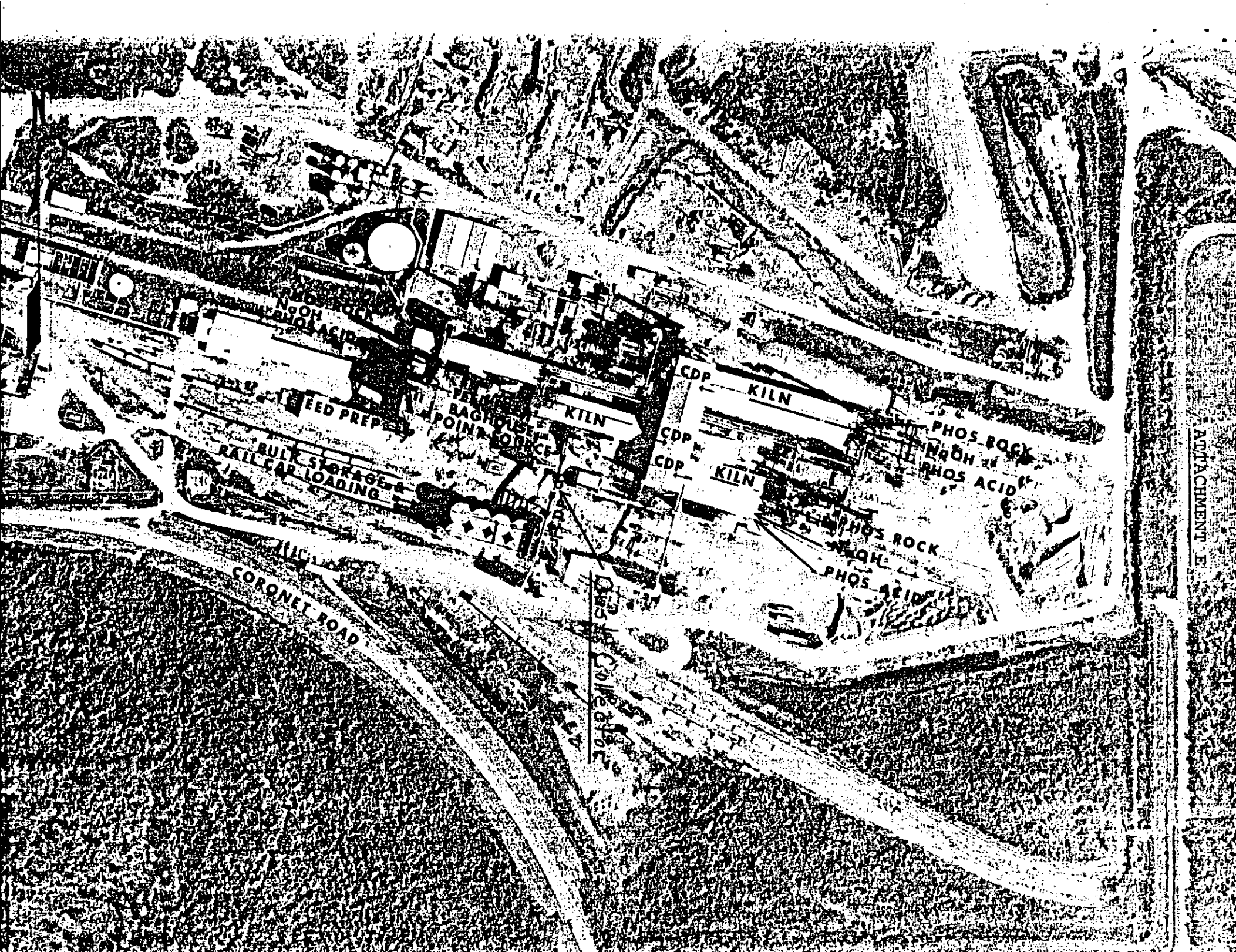

ATTACHMENT E

AMAX Chemical Corporation

A SUBSIDIARY OF AMAX INC.

P. O. BOX 790 ♦ PLANT CITY, FLORIDA 34289 ♦ (813) 752-1161

December 18, 1984

Mr. C. H. Fancy, P.E.
Bureau of Air Quality Management
Florida Department of
Environmental Regulation
Twin Towers Office Building
2600 Blair Stone Road
Tallahassee, FL 32301-8241

Dear Mr. Fancy:

In response to a letter of incompleteness concerning File No. AC29-091316, the Phosphoric Acid Defluorination Facility Scrubber, and File No. AC29-091317, the Conveyor Belt Transfer Point Dust Collector, we are submitting a revised permit application for the phosphoric acid defluorination facility modification and the following responses as the questions were presented.

RE: File No. AC29-091316

1. An addition has been made to drawing D-1 to indicate the proposed air pollution control equipment as it relates to the process, and a new drawing (D-2) has been added (see the revised permit application).
2. See Section II: A of the revised permit application.
3. All raw material for the phosphoric acid defluorination facility are manufactured off-site. The phosphoric acid is received in railcars and is pumped, closed pipe, to storage or defluorinating tanks as needed. Caustic solution used in the process is brought in by tank truck and pump, closed pipe, to the storage tank. Diatomaceous earth (D.E.) is received in 50 pound bags and is initially put into the process by hand. The D.E. is then pumped as a slurry to the acid defluorinating tank as needed.
4. See the BACT determination attached to the revised permit for a similar process at the Occidental Chemical Company. However, the Occidental process is designed to strip the fluoride from the acid in the form of SiF_6 ; whereas the AMAX process is designed to precipitate the majority of the fluoride in the form of Na_2SiF_6 .

5. The operating conditions for the proposed scrubber are as follows:
Scrubber Water Pressure, 45-75 psig
Scrubber Water Flow, 30-40 gpm
Gas Pressure Drop, 5.0-6.0" H₂O
6. Please see Section III: A and B of the revised permit application. Typical laboratory analyses of the phosphoric acid used in the process is 50-54% with an overall average of 52%.
7. In the revised permit application the allowable fluoride emission is shown as 0.86 lbs/hr. This figure was calculated using the 0.04 lbs/ton of P₂O₅ input reflected in the attached BACT determination for a like process.
8. There should be no significant increase in fluoride emission from the process water ponds. The process water from the proposed scrubber, as with all process water, will be treated to precipitate fluorides from the process water. Furthermore, the approximately 32 tons maximum per year pond input from this scrubber would have a minor impact on the total pond volumes.
9. The inlet loadings shown in the revised permit application are 3.6 lbs/hr for particulate matter and 31.28 lbs/hr for fluorides. These were determined from test data collected at the process. When the phosphoric acid is purchased laboratory analysis is routinely performed. The fluoride content for acid used in the process is typically 0.60-1.1% with an overall average of 0.85%.
10. Please see Attachment A for the calculations used to determine the fluoride removal efficiency of 99+% for the proposed scrubber. At this time there is no actual data available to establish a particulate removal efficiency for the proposed scrubber. However, AMAX is reasonably assured the proposed scrubber will be more than adequate for this application. Furthermore, AMAX will guarantee the scrubber will meet the 0.015 grain/ACF established as BACT for a similar process (see Attachment G of the revised permit application). The particle size distribution and the mean diameter of the diatomaceous earth are shown in Attachment A of this letter.
11. In the revised permit application the linear velocity of the stack is approximately 63.66 FPS and the stack diameter is 1.0 feet.

The revised permit application for the phosphoric acid defluorination facility is to replace, in its entirety, the previous application--File No. AC29-091316. This is necessary due to the changes in and correction to the previous application.

Mr. C. H. Fancy
December 18, 1984
Page Three

RE: File No. AC29-091317

1. See Attachment B.
2. The conveyor belt begins at the CDP product storage bins. As product is removed from the bins it enters an enclosed screw conveyor where a dedusting agent is added. The product exits the screw conveyor via a chute and onto a covered belt conveyor. This belt, after a 90° transfer point, continues on to the bulk storage bins to be loaded onto railcar as customer requirements dictate.
3. The belt discharges into an enclosure/chute. At this point, with possible exception of some belt carry-over, the dedusting agent has agglomerated the fine particles to virtually eliminate any further dusting at the discharge point.
4. See 1, 2, and 3.
5. HCEPC did not agree in writing to accept 0.02 grains/DSCF as the emission standard.
6. See Attachment C.
7. Moisture content of the gas is approximately 3-4 percent.

We are also requesting the start of construction and the completion of construction dates of the transfer point dust collector project be changed. The start of construction should be changed from September 1, 1984 to March 1, 1984; and the construction completion date should be changed from December 1, 1984 to August 1, 1984.

Should additional information be required, please let me know.

Sincerely,



George Townsend
Environmental Supervisor

GT/cw

attachments

cc: Bill Thomas (DER)
Steve Gerrog (HCEPC)
J. J. Lewis
F. G. Mullins

BEFORE THE STATE OF FLORIDA
DEPARTMENT OF ENVIRONMENTAL REGULATION

In the Matter of an)
Application for Permit by)
)
AMAX Chemical Corporation) DER File No. AC 29-091317
P.O. Box 790)
Plant City, Florida 33566)
)
)

INTENT TO ISSUE

The Department of Environmental Regulation hereby gives notice of its Intent to Issue, and proposed order of issuance for, a permit pursuant to Chapter 403, Florida Statutes, for the proposed project as detailed in the application specified above. The Department is issuing this Intent to Issue for the reasons stated in the attached Technical Evaluation and Preliminary Determination.

The applicant, AMAX Chemical Corporation, applied on July 23, 1984, to the Department of Environmental Regulation for a permit to construct a dust collector at the transfer point for the two covered animal feed supplement conveyors. The additional information supplied in the letter dated December 18, 1984, (received January 11, 1985) completed the application.

The Department has permitting jurisdiction under Chapter 403, Florida Statutes and Florida Administrative Code Rules 17-2 and 17-4. The project is not exempt from permitting procedures. The applicant was officially notified by the Department that an air construction permit was required for the proposed work.

This intent to issue shall be placed before the Secretary for final action unless an appropriate petition for a hearing pursuant to the provisions of Section 120.57, Florida Statutes, is filed within fourteen (14) days from receipt of this letter or

publication of the public notice (copy attached) required pursuant to Rule 17-103.150, Florida Administrative Code, whichever occurs first. The petition must comply with the requirements of Section 17-103.155 and Rule 28-5.201, Florida Administrative Code (copy attached) and be filed pursuant to Rule 17-103.155(1) in the Office of General Counsel of the Department of Environmental Regulation at 2600 Blair Stone Road, Tallahassee, Florida 32301.

Petitions which are not filed in accordance with the above provisions are subject to dismissal by the Department. In the event a formal hearing is conducted pursuant to Section 120.57(1), all parties shall have opportunity to respond, to present evidence and argument on all issues involved, to conduct cross-examination of witness and submit rebuttal evidence, to submit proposed findings of facts and orders, to file exceptions to any order or hearing officer's recommended order, and to be represented by counsel. If an informal hearing is requested, the agency, in accordance with its rules of procedure, will provide affected persons or parties or their counsel an opportunity, at a convenient time and place, to present to the agency or hearing officer, written or oral evidence in opposition to the agency's action or refusal to act, or a written statement challenging the grounds upon which the agency has chosen to justify its action or inaction, pursuant to Section 120.57(2), Florida Statutes.

If a petition is filed, the administrative hearing process is designed to formulate agency action. Accordingly, the Department's final action may be different from the proposed agency action. Therefore, persons who may not wish to file a petition, may wish to intervene in the proceeding. A petition for intervention must be filed pursuant to Model Rule 28-5.207 at least five (5) days before the final hearing and be filed with the hearing officer if one has been assigned at the Division of

Administrative Hearings, 2009 Apalachee Parkway, Tallahassee, Florida 32301. If no hearing officer has been assigned, the petition is to be filed with the Department's Office of General Counsel, 2600 Blair Stone Road, Tallahassee, Florida 32301. Failure to petition to intervene within the allowed time frame constitutes a waiver of any right such person has to request a hearing under Section 120.57, Florida Statutes.

Executed the 6 day of FEBRUARY, 1985, in Tallahassee, Florida.

STATE OF FLORIDA DEPARTMENT
OF ENVIRONMENTAL REGULATION

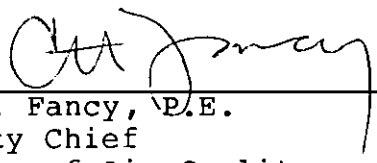

C. H. Fancy, P.E.
Deputy Chief
Bureau of Air Quality
Management

Copies furnished to:

J.J. Lewis, AMAX Chemical Corporation
Bill Thomas, SW District
Steve Gyrog, HCEPC