

# McKay Bay Refuse-to-Energy Facility

## Title V Air Operations Permit Renewal



Prepared for:  
**City of Tampa**  
**Solid Waste Department**

*October 2010*

**MALCOLM  
PIRNIE**

1300 East 8<sup>th</sup> Avenue, Suite F100, Tampa, Florida 33605

October 27, 2010

Yousry (Joe) Attalla  
Florida Department of Environmental Protection  
Bureau of Air Regulation  
2600 Blair Stone Road  
Mail Station 5505  
Tallahassee, Florida 32399

**RECEIVED****OCT 28 2010****BUREAU OF  
AIR REGULATION**

Re: City of Tampa  
McKay Bay Refuse-to-Energy Facility  
Renewal of Title V Permit No. 0570127-005-AV

Dear Mr. Attalla:

*Project No.: 0570127-006-AV*

On behalf of the City of Tampa, Malcolm Pirnie, Inc. is pleased to submit the Title V Air Operation Permit Renewal Application for the McKay Bay Refuse-to-Energy Facility, Tampa, Florida. Enclosed please find two (2) copies of the Title V Permit Renewal Application for your review and approval.

Should you have any questions or need additional information, please do not hesitate to contact me at (239) 332-1300 or Tamara Stankunas, Earthshine Environmental, Inc. at (813) 545-7067. We look forward to working with you and the Department.

Very truly yours,

MALCOLM PIRNIE, INC.

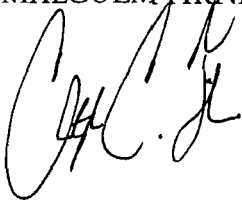

Christopher C. Tilman, P.E.  
Senior Consultant

- c: S. Woodard, Environmental Protection Commission of Hillsborough County  
S. Daignault, City of Tampa  
N. McCann, City of Tampa  
G. Grotecloss, City of Tampa  
H. McKnight, Wheelabrator McKay Bay, Inc.  
S. Rosania, Malcolm Pirnie, Inc.  
C. Tilman, Malcolm Pirnie, Inc.  
T. Stankunas, Earthshine Environmental, Inc.



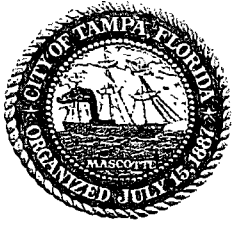

**City of Tampa**

306 East Jackson Street • 8N • Tampa, Florida 33602

RECEIVED

OCT 28 2010

BUREAU OF  
AIR REGULATION

# McKay Bay Refuse-To-Energy Facility Title V Renewal Application

October 2010

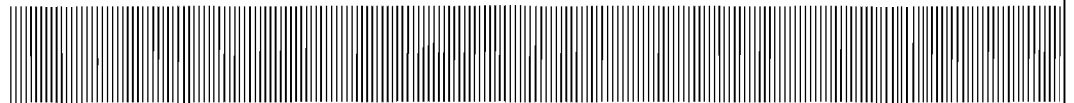

Report Prepared By:

**Malcolm Pirnie, Inc.**

1300 East 8<sup>th</sup> Avenue  
Suite F100  
Tampa, FL 33605  
813-248-6900

0043046

**MALCOLM  
PIRNIE**

Contents

<b>1. Introduction</b>	<b>1-1</b>
<b>2. Application for Air Permit</b>	<b>2-1</b>
<b>3. Facility Additional Information - Additional Requirements for All Applications</b>	<b>3-1</b>
3.1. Facility Plot Plan.....	3-1
3.2. Process Flow Diagrams .....	3-1
3.3. Precautions to Prevent Emissions of Uncontrolled Particulate Matter .....	3-1
<b>4. Facility Additional Information - Additional Requirements for Title V Air Operations Permit Applications</b>	<b>4-1</b>
4.1. List of Insignificant Activities .....	4-1
4.1.1. Activity Descriptions and Emission Estimate Calculations.....	4-2
4.2. List of Applicable Air Quality Regulations .....	4-4
4.2.1. Federal Regulations .....	4-4
4.2.2. Florida Administrative Code (F. A. C.).....	4-4
4.3. Compliance Assurance Monitoring Plan .....	4-6
4.4. Requested Changes to Title V Air Operating Permit .....	4-6
<b>5. Emissions Unit Supplemental Information - All Applications</b>	<b>5-1</b>
5.1. Fuel Analysis or Specifications .....	5-1
5.2. Detailed Description of Control Equipment.....	5-2
5.3. Procedures for Startup and Shutdown.....	5-3
5.4. Operations and Maintenance Plan.....	5-3
5.5. Compliance Report and Plan .....	5-3
5.6. Other Information Required By Rule or Statute .....	5-3

Appendices

- A. Facility Plot Plan
- B. Process Flow Diagrams
- C. Plant Operations Manual and Operating Procedures OP-7 & OP-15
- D. Statement of Compliance and Annual Stack Test Summary

# 1. Introduction

---

The McKay Bay Refuse-To-Energy Facility (the “Facility”) is located in Tampa, Florida and generates electricity from the combustion of approximately 1,000 tons of municipal solid waste per day. The Facility is self-sufficient and operates on a small portion of the electricity it generates. The remaining electricity is sold to the Tampa Electric Company (TECO) for their provision of electricity to local homes and businesses.

The Facility’s major components include four 250 ton per day (nominal) municipal waste combustor (MWC) units with reciprocating grates, a General Electric steam turbine and 22.5 megawatt generator. Each of the four MWC units is equipped with a spray dryer absorber, fabric filter baghouse, a powdered activated carbon injection system, and a selective non-catalytic reduction (SNCR) system.

Facility emissions are currently regulated under permits PSD-FL-086(B) and 0570127-005-AV. Emissions from the four MWC units are monitored by the Continuous Emissions Monitoring System, a complex network of sensors and monitoring equipment that relays emissions data to the Facility operators in the control room. The facility has the following regulated emission sources:

- Four (4) mass-burn municipal waste combustors
- One (1) enclosed ash handling system, including scrubbers that are operated as needed for ash building and handling system
- Two (2) lime silos with common vent filter
- Two (2) activated carbon silos, each silo is equipped with its own vent filter

The Facility has the following unregulated emissions source:

- One (1) cooling tower

The insignificant emission sources include the following:

- Urea storage tank
- Caustic soda tank
- Sulfuric acid tank
- Boiler chemicals
- Cooling tower chemicals

- Solvent degreaser
- Sandblasting equipment
- Diesel fuel above ground storage tank
- Portable air compressors
- Portable welding machines
- Truck traffic
- Refuse pit
- Gasoline above ground storage tank





# Department of Environmental Protection

## Division of Air Resource Management

### APPLICATION FOR AIR PERMIT - LONG FORM

RECEIVED

OCT 28 2010

BUREAU OF AIR REGULATION

#### I. APPLICATION INFORMATION

**Air Construction Permit** – Use this form to apply for an air construction permit:

- For any required purpose at a facility operating under a federally enforceable state air operation permit (FESOP) or Title V air operation permit;
- For a proposed project subject to prevention of significant deterioration (PSD) review, nonattainment new source review, or maximum achievable control technology (MACT);
- To assume a restriction on the potential emissions of one or more pollutants to escape a requirement such as PSD review, nonattainment new source review, MACT, or Title V; or
- To establish, revise, or renew a plantwide applicability limit (PAL).

**Air Operation Permit** – Use this form to apply for:

- An initial federally enforceable state air operation permit (FESOP); or
- An initial, revised, or renewal Title V air operation permit.

To ensure accuracy, please see form instructions.

#### Identification of Facility

1. Facility Owner/Company Name: City of Tampa	
2. Site Name: McKay Bay Refuse-To-Energy Facility	
3. Facility Identification Number: 0570127	
4. Facility Location... Street Address or Other Locator: 107 North 34 <sup>th</sup> Street City: Tampa County: Hillsborough Zip Code: 33605	
5. Relocatable Facility? <input type="checkbox"/> Yes <input checked="" type="checkbox"/> No	6. Existing Title V Permitted Facility? <input checked="" type="checkbox"/> Yes <input type="checkbox"/> No

#### Application Contact

1. Application Contact Name: Christopher C. Tilman, P.E.	
2. Application Contact Mailing Address: Organization/Firm: Malcolm Pirnie, Inc. Street Address: 4315 Metro Parkway, Suite 520 City: Fort Myers State: Florida Zip Code: 33916	
3. Application Contact Telephone Numbers: Telephone: (239) 332 - 1300 ext. Fax: (239) 332 - 1789	
4. Application Contact E-mail Address: ctilman@pirnie.com	

#### Application Processing Information (DEP Use)

1. Date of Receipt of Application: 10-28-10	3. PSD Number (if applicable):
2. Project Number(s): 0570127-0067A	4. Siting Number (if applicable):

## APPLICATION INFORMATION

### Purpose of Application

**This application for air permit is being submitted to obtain: (Check one)**

#### **Air Construction Permit**

- Air construction permit.
- Air construction permit to establish, revise, or renew a plantwide applicability limit (PAL).
- Air construction permit to establish, revise, or renew a plantwide applicability limit (PAL), and separate air construction permit to authorize construction or modification of one or more emissions units covered by the PAL.

#### **Air Operation Permit**

- Initial Title V air operation permit.
- Title V air operation permit revision.
- Title V air operation permit renewal.
- Initial federally enforceable state air operation permit (FESOP) where professional engineer (PE) certification is required.
- Initial federally enforceable state air operation permit (FESOP) where professional engineer (PE) certification is not required.

#### **Air Construction Permit and Revised/Renewal Title V Air Operation Permit (Concurrent Processing)**

- Air construction permit and Title V permit revision, incorporating the proposed project.
- Air construction permit and Title V permit renewal, incorporating the proposed project.

**Note: By checking one of the above two boxes, you, the applicant, are requesting concurrent processing pursuant to Rule 62-213.405, F.A.C. In such case, you must also check the following box:**

- I hereby request that the department waive the processing time requirements of the air construction permit to accommodate the processing time frames of the Title V air operation permit.

### Application Comment

Renewal application for Title V Air Operation Permit No. 0570127-005 AV.



**APPLICATION INFORMATION**

**Scope of Application**

<b>Emissions Unit ID Number</b>	<b>Description of Emissions Unit</b>	<b>Air Permit Type</b>	<b>Air Permit Processing Fee</b>
100	Ash Building and Handling System		
101	Pebble Lime Storage Silos		
102	Activated Carbon Storage Silos		
103	120 MMBtu/hr (max) Municipal Waste Combustor & Auxiliary Burners – Unit 1		
104	120 MMBtu/hr (max) Municipal Waste Combustor & Auxiliary Burners – Unit 2		
105	120 MMBtu/hr (max) Municipal Waste Combustor & Auxiliary Burners – Unit 3		
106	120 MMBtu/hr (max) Municipal Waste Combustor & Auxiliary Burners – Unit 4		
107	Cooling Tower (Unregulated Emissions Unit)		

**Application Processing Fee**

Check one:  Attached - Amount: \$ \_\_\_\_\_  Not Applicable

**APPLICATION INFORMATION**

**Owner/Authorized Representative Statement**

**Complete if applying for an air construction permit or an initial FESOP.**

1. Owner/Authorized Representative Name :
2. Owner/Authorized Representative Mailing Address... Organization/Firm: Street Address: City: State: Zip Code:
3. Owner/Authorized Representative Telephone Number Telephone: ( ) - ext. Fax: ( )
4. Owner/Authorized Representative E-mail Address:
5. Owner/Authorized Representative Statement: <i>I, the undersigned, am the owner or authorized representative of the corporation, partnership, or other legal entity submitting this air permit application. To the best of my knowledge, the statements made in this application are true, accurate and complete, and any estimates of emissions reported in this application are based upon reasonable techniques for calculating emissions. I understand that a permit, if granted by the department, cannot be transferred without authorization from the department.</i>  _____ Signature  _____ Date

**NOT APPLICABLE**

**APPLICATION INFORMATION**

**Application Responsible Official Certification**

**Complete if applying for an initial, revised, or renewal Title V air operation permit or concurrent processing of an air construction permit and revised or renewal Title V air operation permit. If there are multiple responsible officials, the "application responsible official" need not be the "primary responsible official."**

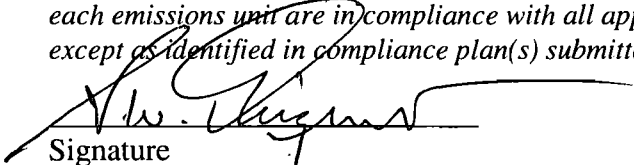
1. Application Responsible Official Name: Steve W. Daignault, P.E.
2. Application Responsible Official Qualification (Check one or more of the following options, as applicable): <input type="checkbox"/> For a corporation, the president, secretary, treasurer, or vice-president of the corporation in charge of a principal business function, or any other person who performs similar policy or decision-making functions for the corporation, or a duly authorized representative of such person if the representative is responsible for the overall operation of one or more manufacturing, production, or operating facilities applying for or subject to a permit under Chapter 62-213, F.A.C. <input type="checkbox"/> For a partnership or sole proprietorship, a general partner or the proprietor, respectively. <input checked="" type="checkbox"/> For a municipality, county, state, federal, or other public agency, either a principal executive officer or ranking elected official. <input type="checkbox"/> The designated representative at an Acid Rain source or CAIR source.
3. Application Responsible Official Mailing Address: Organization/Firm: Public Works and Utilities Services, City of Tampa Street Address: 306 East Jackson Street City: Tampa State: Florida Zip Code: 33602
4. Application Responsible Official Telephone Numbers... Telephone: (813) 274 - 7883 ext. Fax: (813) 274 - 8127
5. Application Responsible Official E-mail Address: <u>steve.daignault@tampagov.net</u>
6. Application Responsible Official Certification: <i>I, the undersigned, am a responsible official of the Title V source addressed in this air permit application. I hereby certify, based on information and belief formed after reasonable inquiry, that the statements made in this application are true, accurate and complete and that, to the best of my knowledge, any estimates of emissions reported in this application are based upon reasonable techniques for calculating emissions. The air pollutant emissions units and air pollution control equipment described in this application will be operated and maintained so as to comply with all applicable standards for control of air pollutant emissions found in the statutes of the State of Florida and rules of the Department of Environmental Protection and revisions thereof and all other applicable requirements identified in this application to which the Title V source is subject. I understand that a permit, if granted by the department, cannot be transferred without authorization from the department, and I will promptly notify the department upon sale or legal transfer of the facility or any permitted emissions unit. Finally, I certify that the facility and each emissions unit are in compliance with all applicable requirements to which they are subject, except as identified in compliance plan(s) submitted with this application.</i>  Signature <u>10/22/10</u> Date

**APPLICATION INFORMATION**

**Professional Engineer Certification**

1. Professional Engineer Name: Christopher C. Tilman, P.E. Registration Number: 61903
2. Professional Engineer Mailing Address: Organization/Firm: Malcolm Pirnie, Inc. Street Address: 4315 Metro Parkway, Suite 520 City: Fort Myers State: Florida Zip Code: 33916
3. Professional Engineer Telephone Numbers: Telephone: (239) 332 - 1300 ext. Fax: (239) 332 - 1789
4. Professional Engineer E-mail Address: <u>ctilman@pirnie.com</u>
5. Professional Engineer Statement: <i>I, the undersigned, hereby certify, except as particularly noted herein*, that:</i> <i>(1) To the best of my knowledge, there is reasonable assurance that the air pollutant emissions unit(s) and the air pollution control equipment described in this application for air permit, when properly operated and maintained, will comply with all applicable standards for control of air pollutant emissions found in the Florida Statutes and rules of the Department of Environmental Protection; and</i> <i>(2) To the best of my knowledge, any emission estimates reported or relied on in this application are true, accurate, and complete and are either based upon reasonable techniques available for calculating emissions or, for emission estimates of hazardous air pollutants not regulated for an emissions unit addressed in this application, based solely upon the materials, information and calculations submitted with this application.</i> <i>(3) If the purpose of this application is to obtain a Title V air operation permit (check here <input checked="" type="checkbox"/>, if so), I further certify that each emissions unit described in this application for air permit, when properly operated and maintained, will comply with the applicable requirements identified in this application to which the unit is subject, except those emissions units for which a compliance plan and schedule is submitted with this application.</i> <i>(4) If the purpose of this application is to obtain an air construction permit (check here <input type="checkbox"/>, if so) or concurrently process and obtain an air construction permit and a Title V air operation permit revision or renewal for one or more proposed new or modified emissions units (check here <input type="checkbox"/>, if so), I further certify that the engineering features of each such emissions unit described in this application have been designed or examined by me or individuals under my direct supervision and found to be in conformity with sound engineering principles applicable to the control of emissions of the air pollutants characterized in this application.</i> <i>(5) If the purpose of this application is to obtain an initial air operation permit or operation permit revision or renewal for one or more newly constructed or modified emissions units (check here <input type="checkbox"/>, if so), I further certify that, with the exception of any changes detailed as part of this application, each such emissions unit has been constructed or modified in substantial accordance with the information given in the corresponding application for air construction permit and with all provisions contained in such permit.</i>  Signature _____ Date <u>10-19-10</u> (seal)

\* Attach any exception to certification statement.

## II. FACILITY INFORMATION

### A. GENERAL FACILITY INFORMATION

#### Facility Location and Type

1. Facility UTM Coordinates... Zone 17      East (km)    360.0 North (km)    3091.9		2. Facility Latitude/Longitude... Latitude (DD/MM/SS) 27 <sup>0</sup> 56'51" Longitude (DD/MM/SS) 82 <sup>0</sup> 25'14"	
3. Governmental Facility Code: 3	4. Facility Status Code: A	5. Facility Major Group SIC Code: 49	6. Facility SIC(s): 4953
7. Facility Comment :  None			

#### Facility Contact

1. Facility Contact Name: Greig Grotecloss
2. Facility Contact Mailing Address: Organization/Firm: McKay Bay Refuse-To-Energy Facility Street Address: 107 North 34 <sup>th</sup> Street <div style="display: flex; justify-content: space-between; margin-top: 5px;"> <span>City: Tampa</span> <span>State: Florida</span> <span>Zip Code: 33605</span> </div>
3. Facility Contact Telephone Numbers: Telephone: (813) 242 - 5408      ext.      Fax:      (813) 247 - 2052
4. Facility Contact E-mail Address: greig.grotecloss@ci.tampa.fl.us

#### Facility Primary Responsible Official

**Complete if an "application responsible official" is identified in Section I that is not the facility "primary responsible official."**

1. Facility Primary Responsible Official Name:
2. Facility Primary Responsible Official Mailing Address: Organization/Firm: Street Address: <div style="display: flex; justify-content: space-between; margin-top: 5px;"> <span>City:</span> <span>State:</span> <span>Zip Code:</span> </div>
3. Facility Primary Responsible Official Telephone Numbers: Telephone: ( ) -      ext.      Fax: ( ) -
4. Facility Primary Responsible Official E-mail Address:

## FACILITY INFORMATION

### Facility Regulatory Classifications

Check all that would apply *following* completion of all projects and implementation of all other changes proposed in this application for air permit. Refer to instructions to distinguish between a “major source” and a “synthetic minor source.”

1. <input type="checkbox"/> Small Business Stationary Source	<input type="checkbox"/> Unknown
2. <input type="checkbox"/> Synthetic Non-Title V Source	
3. <input checked="" type="checkbox"/> Title V Source	
4. <input checked="" type="checkbox"/> Major Source of Air Pollutants, Other than Hazardous Air Pollutants (HAPs)	
5. <input type="checkbox"/> Synthetic Minor Source of Air Pollutants, Other than HAPs	
6. <input checked="" type="checkbox"/> Major Source of Hazardous Air Pollutants (HAPs)	
7. <input type="checkbox"/> Synthetic Minor Source of HAPs	
8. <input checked="" type="checkbox"/> One or More Emissions Units Subject to NSPS (40 CFR Part 60)	
9. <input checked="" type="checkbox"/> One or More Emissions Units Subject to Emission Guidelines (40 CFR Part 60)	
10. <input type="checkbox"/> One or More Emissions Units Subject to NESHAP (40 CFR Part 61 or Part 63)	
11. <input type="checkbox"/> Title V Source Solely by EPA Designation (40 CFR 70.3(a)(5))	
12. Facility Regulatory Classifications Comment:  Emissions limited by Florida permit no. PSD-FL-086(B)	

# FACILITY INFORMATION

## List of Pollutants Emitted by Facility

1. Pollutant Emitted	2. Pollutant Classification	3. Emissions Cap [Y or N]?
PM	A	N
SO <sub>2</sub>	A	Y
NO <sub>x</sub>	A	Y
CO	A	Y
H106	A	N
H107	B	N
PB	B	N
H021	B	N
H114	B	N
D/F	B	N
H027	B	N

**FACILITY INFORMATION**

**B. EMISSIONS CAPS**

**Facility-Wide or Multi-Unit Emissions Caps**

1. Pollutant Subject to Emissions Cap	2. Facility-Wide Cap [Y or N]? (all units)	3. Emissions Unit ID's Under Cap (if not all units)	4. Hourly Cap (lb/hr)	5. Annual Cap (ton/yr)	6. Basis for Emissions Cap
SO <sub>2</sub>				460.0	See 7 below
NO <sub>x</sub>				679.0	See 7 below
CO				185.0	See 7 below

7. Facility-Wide or Multi-Unit Emissions Cap Comment:

PSD-FL-086(B) Facility-wide specific condition B.8 emissions limits for SO<sub>2</sub>, NO<sub>x</sub>, and CO.



## FACILITY INFORMATION

### C. FACILITY ADDITIONAL INFORMATION

#### Additional Requirements for All Applications, Except as Otherwise Stated

1. Facility Plot Plan: (Required for all permit applications, except Title V air operation permit revision applications if this information was submitted to the department within the previous five years and would not be altered as a result of the revision being sought) <input checked="" type="checkbox"/> Attached, Document ID: <u>Appendix A</u> <input type="checkbox"/> Previously Submitted, Date: _____
2. Process Flow Diagram(s): (Required for all permit applications, except Title V air operation permit revision applications if this information was submitted to the department within the previous five years and would not be altered as a result of the revision being sought) <input checked="" type="checkbox"/> Attached, Document ID: <u>Appendix B</u> <input type="checkbox"/> Previously Submitted, Date: _____
3. Precautions to Prevent Emissions of Unconfined Particulate Matter: (Required for all permit applications, except Title V air operation permit revision applications if this information was submitted to the department within the previous five years and would not be altered as a result of the revision being sought) <input checked="" type="checkbox"/> Attached, Document ID: <u>See Section 3</u> <input type="checkbox"/> Previously Submitted, Date: _____

#### Additional Requirements for Air Construction Permit Applications

1. Area Map Showing Facility Location: <input type="checkbox"/> Attached, Document ID: _____ <input checked="" type="checkbox"/> Not Applicable (existing permitted facility)
2. Description of Proposed Construction, Modification, or Plantwide Applicability Limit (PAL): <input type="checkbox"/> Attached, Document ID: _____
3. Rule Applicability Analysis: <input type="checkbox"/> Attached, Document ID: _____
4. List of Exempt Emissions Units: <input type="checkbox"/> Attached, Document ID: _____ <input checked="" type="checkbox"/> Not Applicable (no exempt units at facility)
5. Fugitive Emissions Identification: <input type="checkbox"/> Attached, Document ID: _____ <input checked="" type="checkbox"/> Not Applicable
6. Air Quality Analysis (Rule 62-212.400(7), F.A.C.): <input type="checkbox"/> Attached, Document ID: _____ <input checked="" type="checkbox"/> Not Applicable
7. Source Impact Analysis (Rule 62-212.400(5), F.A.C.): <input type="checkbox"/> Attached, Document ID: _____ <input checked="" type="checkbox"/> Not Applicable
8. Air Quality Impact since 1977 (Rule 62-212.400(4)(e), F.A.C.): <input type="checkbox"/> Attached, Document ID: _____ <input checked="" type="checkbox"/> Not Applicable
9. Additional Impact Analyses (Rules 62-212.400(8) and 62-212.500(4)(e), F.A.C.): <input type="checkbox"/> Attached, Document ID: _____ <input checked="" type="checkbox"/> Not Applicable
10. Alternative Analysis Requirement (Rule 62-212.500(4)(g), F.A.C.): <input type="checkbox"/> Attached, Document ID: _____ <input checked="" type="checkbox"/> Not Applicable

## FACILITY INFORMATION

### C. FACILITY ADDITIONAL INFORMATION (CONTINUED)

#### Additional Requirements for FESOP Applications

- |  |
|--|
| 1. List of Exempt Emissions Units:<br><input type="checkbox"/> Attached, Document ID: _____ <input checked="" type="checkbox"/> Not Applicable (no exempt units at facility) |
|--|

#### Additional Requirements for Title V Air Operation Permit Applications

- |  |
|--|
| 1. List of Insignificant Activities: (Required for initial/renewal applications only)<br><input checked="" type="checkbox"/> Attached, Document ID: <u>See Section 4</u> <input type="checkbox"/> Not Applicable (revision application)  |
| 2. Identification of Applicable Requirements: (Required for initial/renewal applications, and for revision applications if this information would be changed as a result of the revision being sought)<br><input checked="" type="checkbox"/> Attached, Document ID: <u>See Section 4</u><br><input type="checkbox"/> Not Applicable (revision application with no change in applicable requirements)  |
| 3. Compliance Report and Plan: (Required for all initial/revision/renewal applications)<br><input checked="" type="checkbox"/> Attached, Document ID: <u>See Section 5</u><br>Note: A compliance plan must be submitted for each emissions unit that is not in compliance with all applicable requirements at the time of application and/or at any time during application processing. The department must be notified of any changes in compliance status during application processing. |
| 4. List of Equipment/Activities Regulated under Title VI: (If applicable, required for initial/renewal applications only)<br><input type="checkbox"/> Attached, Document ID: _____<br><input type="checkbox"/> Equipment/Activities Onsite but Not Required to be Individually Listed<br><input checked="" type="checkbox"/> Not Applicable  |
| 5. Verification of Risk Management Plan Submission to EPA: (If applicable, required for initial/renewal applications only)<br><input type="checkbox"/> Attached, Document ID: _____ <input checked="" type="checkbox"/> Not Applicable   |
| 6. Requested Changes to Current Title V Air Operation Permit:<br><input checked="" type="checkbox"/> Attached, Document ID: <u>See Section 4</u> <input type="checkbox"/> Not Applicable   |

**FACILITY INFORMATION**

**C. FACILITY ADDITIONAL INFORMATION (CONTINUED)**

**Additional Requirements for Facilities Subject to Acid Rain, CAIR, or Hg Budget Program**

1. Acid Rain Program Forms:

Acid Rain Part Application (DEP Form No. 62-210.900(1)(a)):

Attached, Document ID: \_\_\_\_\_  Previously Submitted, Date: \_\_\_\_\_

Not Applicable (not an Acid Rain source)

Phase II NO<sub>x</sub> Averaging Plan (DEP Form No. 62-210.900(1)(a)1.):

Attached, Document ID: \_\_\_\_\_  Previously Submitted, Date: \_\_\_\_\_

Not Applicable

New Unit Exemption (DEP Form No. 62-210.900(1)(a)2.):

Attached, Document ID: \_\_\_\_\_  Previously Submitted, Date: \_\_\_\_\_

Not Applicable

**Not Applicable**

2. CAIR Part (DEP Form No. 62-210.900(1)(b)):

Attached, Document ID: \_\_\_\_\_  Previously Submitted, Date: \_\_\_\_\_

Not Applicable (not a CAIR source)

**Additional Requirements Comment**

Empty rectangular box for additional requirements comment.

**EMISSIONS UNIT INFORMATION**

Section [ ] of [ ]

**III. EMISSIONS UNIT INFORMATION**

**Title V Air Operation Permit Application** - For Title V air operation permitting only, emissions units are classified as regulated, unregulated, or insignificant. If this is an application for an initial, revised or renewal Title V air operation permit, a separate Emissions Unit Information Section (including subsections A through I as required) must be completed for each regulated and unregulated emissions unit addressed in this application. Some of the subsections comprising the Emissions Unit Information Section of the form are optional for unregulated emissions units. Each such subsection is appropriately marked. Insignificant emissions units are required to be listed at Section II, Subsection C.

**Air Construction Permit or FESOP Application** - For air construction permitting or federally enforceable state air operation permitting, emissions units are classified as either subject to air permitting or exempt from air permitting. The concept of an "unregulated emissions unit" does not apply. If this is an application for an air construction permit or FESOP, a separate Emissions Unit Information Section (including subsections A through I as required) must be completed for each emissions unit subject to air permitting addressed in this application for air permit. Emissions units exempt from air permitting are required to be listed at Section II, Subsection C.

**Air Construction Permit and Revised/Renewal Title V Air Operation Permit Application** – Where this application is used to apply for both an air construction permit and a revised or renewal Title V air operation permit, each emissions unit is classified as either subject to air permitting or exempt from air permitting for air construction permitting purposes, and as regulated, unregulated, or insignificant for Title V air operation permitting purposes. A separate Emissions Unit Information Section (including subsections A through I as required) must be completed for each emissions unit addressed in this application that is subject to air construction permitting and for each such emissions unit that is a regulated or unregulated unit for purposes of Title V permitting. (An emissions unit may be exempt from air construction permitting but still be classified as an unregulated unit for Title V purposes.) Emissions units classified as insignificant for Title V purposes are required to be listed at Section II, Subsection C.

If submitting the application form in hard copy, the number of this Emissions Unit Information Section and the total number of Emissions Unit Information Sections submitted as part of this application must be indicated in the space provided at the top of each page.

**EMISSIONS UNIT INFORMATION**

Section [1] of [8]

**A. GENERAL EMISSIONS UNIT INFORMATION**

**Title V Air Operation Permit Emissions Unit Classification**

1. Regulated or Unregulated Emissions Unit? (Check one, if applying for an initial, revised or renewal Title V air operation permit. Skip this item if applying for an air construction permit or FESOP only.)

The emissions unit addressed in this Emissions Unit Information Section is a regulated emissions unit.

The emissions unit addressed in this Emissions Unit Information Section is an unregulated emissions unit.

**Emissions Unit Description and Status**

1. Type of Emissions Unit Addressed in this Section: (Check one)

This Emissions Unit Information Section addresses, as a single emissions unit, a single process or production unit, or activity, which produces one or more air pollutants and which has at least one definable emission point (stack or vent).

This Emissions Unit Information Section addresses, as a single emissions unit, a group of process or production units and activities which has at least one definable emission point (stack or vent) but may also produce fugitive emissions.

This Emissions Unit Information Section addresses, as a single emissions unit, one or more process or production units and activities which produce fugitive emissions only.

2. Description of Emissions Unit Addressed in this Section:

Ash Handling System including scrubber for ash building and scalper building.

3. Emissions Unit Identification Number: 100

4. Emissions Unit Status Code:  
A

5. Commence Construction Date:

6. Initial Startup Date:  
08/30/2001

7. Emissions Unit Major Group SIC Code: 49

8. Federal Program Applicability: (Check all that apply)

Acid Rain Unit **Not Applicable**

CAIR Unit

9. Package Unit:

Manufacturer: Tri-Mer Corp.

Model Number:

10. Generator Nameplate Rating: MW **Not Applicable**

11. Emissions Unit Comment:

**EMISSIONS UNIT INFORMATION**

Section [1] of [8]

**Emissions Unit Control Equipment/Method:** Control \_\_\_ of \_\_\_

- |  |
|--|
| 1. Control Equipment/Method Description:<br>This emissions unit uses two wet scrubbers and a containment building to control fugitive emissions. |
| 2. Control Device or Method Code: 141, 54  |

**Emissions Unit Control Equipment/Method:** Control \_\_\_ of \_\_\_

- |  |
|--|
| 1. Control Equipment/Method Description: |
| 2. Control Device or Method Code:        |

**Emissions Unit Control Equipment/Method:** Control \_\_\_ of \_\_\_

- |  |
|--|
| 1. Control Equipment/Method Description: |
| 2. Control Device or Method Code:        |

**Emissions Unit Control Equipment/Method:** Control \_\_\_ of \_\_\_

- |  |
|--|
| 1. Control Equipment/Method Description: |
| 2. Control Device or Method Code:        |

**EMISSIONS UNIT INFORMATION**

Section [1] of [8]

**B. EMISSIONS UNIT CAPACITY INFORMATION**

**(Optional for unregulated emissions units.)**

**Emissions Unit Operating Capacity and Schedule**

1. Maximum Process or Throughput Rate: 280 tons/day (see note 6)
2. Maximum Production Rate:
3. Maximum Heat Input Rate: million Btu/hr
4. Maximum Incineration Rate: pounds/hr tons/day
5. Requested Maximum Operating Schedule: 24 hours/day 7 days/week 52 weeks/year 8,760 hours/year
6. Operating Capacity/Schedule Comment:  280 tons/day maximum process/throughput rate is provided for informational purposes only, and is not a compliance requirement.

**EMISSIONS UNIT INFORMATION**

Section [1] of [8]

**C. EMISSION POINT (STACK/VENT) INFORMATION**

**(Optional for unregulated emissions units.)**

**Emission Point Description and Type**

1. Identification of Point on Plot Plan or Flow Diagram: See Appendix A		2. Emission Point Type Code: 3	
3. Descriptions of Emission Points Comprising this Emissions Unit for VE Tracking:  Ash handling system scrubber stacks			
4. ID Numbers or Descriptions of Emission Units with this Emission Point in Common:  <b>Not Applicable</b>			
5. Discharge Type Code: V	6. Stack Height: 50 feet	7. Exit Diameter: 1.3 feet	
8. Exit Temperature: °F N/A	9. Actual Volumetric Flow Rate: acfm	10. Water Vapor: % N/A	
11. Maximum Dry Standard Flow Rate: dscfm		12. Nonstack Emission Point Height: feet	
13. Emission Point UTM Coordinates... Zone: 17 East (km): North (km):		14. Emission Point Latitude/Longitude... Latitude (DD/MM/SS) Longitude (DD/MM/SS)	
15. Emission Point Comment:			



**EMISSIONS UNIT INFORMATION**

Section [1] of [8]

**D. SEGMENT (PROCESS/FUEL) INFORMATION**

**Segment Description and Rate:** Segment 1 of 2

1. Segment Description (Process/Fuel Type):  Industrial Processes – Mineral Processes Bulk Materials Conveyors – Other Not Classified		
2. Source Classification Code (SCC): 30510199		3. SCC Units: Tons transferred or handled
4. Maximum Hourly Rate:	5. Maximum Annual Rate:	6. Estimated Annual Activity Factor:
7. Maximum % Sulfur: N/A	8. Maximum % Ash: N/A	9. Million Btu per SCC Unit: N/A
10. Segment Comment:		

**Segment Description and Rate:** Segment 2 of 2

1. Segment Description (Process/Fuel Type):		
2. Source Classification Code (SCC):		3. SCC Units:
4. Maximum Hourly Rate:	5. Maximum Annual Rate:	6. Estimated Annual Activity Factor:
7. Maximum % Sulfur:	8. Maximum % Ash:	9. Million Btu per SCC Unit:
10. Segment Comment:		

**EMISSIONS UNIT INFORMATION**

Section [1] of [8]

**E. EMISSIONS UNIT POLLUTANTS**

**List of Pollutants Emitted by Emissions Unit**

1. Pollutant Emitted	2. Primary Control Device Code	3. Secondary Control Device Code	4. Pollutant Regulatory Code
<b>VE (Opacity)</b>	<b>141</b>	<b>054</b>	<b>EL</b>

F1. EMISSIONS UNIT POLLUTANT DETAIL INFORMATION – POTENTIAL, FUGITIVE, AND ACTUAL EMISSIONS (Optional for unregulated emissions units.)

Complete a Subsection F1 for each pollutant identified in Subsection E if applying for an air construction permit or concurrent processing of an air construction permit and a revised or renewal Title V operation permit. Complete for each emissions-limited pollutant identified in Subsection E if applying for an air operation permit.

Potential, Estimated Fugitive, and Baseline & Projected Actual Emissions

Form with fields for: 1. Pollutant Emitted; 2. Total Percent Efficiency of Control; 3. Potential Emissions; 4. Synthetically Limited?; 5. Range of Estimated Fugitive Emissions; 6. Emission Factor; 7. Emissions Method Code; 8.a. Baseline Actual Emissions; 8.b. Baseline 24-month Period; 9.a. Projected Actual Emissions; 9.b. Projected Monitoring Period; 10. Calculation of Emissions; 11. Potential, Fugitive, and Actual Emissions Comment.

Not Applicable

**F2. EMISSIONS UNIT POLLUTANT DETAIL INFORMATION -  
ALLOWABLE EMISSIONS**

**Complete Subsection F2 if the pollutant identified in Subsection F1 is or would be subject to a numerical emissions limitation.**

**Allowable Emissions** Allowable Emissions \_\_\_ of \_\_\_

1. Basis for Allowable Emissions Code:	2. Future Effective Date of Allowable Emissions:
3. Allowable Emissions and Units:	4. Equivalent Allowable Emissions: lb/hour                      tons/year
5. Method of Compliance:	
6. Allowable Emissions Comment (Description of Operating Method):	

**Allowable Emissions** Allowable Emissions \_\_\_ of \_\_\_

1. Basis for Allowable Emissions Code:	2. Future Effective Date of Allowable Emissions:
3. Allowable Emissions and Units:	4. Equivalent Allowable Emissions: lb/hour                      tons/year
5. Method of Compliance:	
6. Allowable Emissions Comment (Description of Operating Method):	

**Not Applicable**

**Allowable Emissions** Allowable Emissions \_\_\_ of \_\_\_

1. Basis for Allowable Emissions Code:	2. Future Effective Date of Allowable Emissions:
3. Allowable Emissions and Units:	4. Equivalent Allowable Emissions: lb/hour                      tons/year
5. Method of Compliance:	
6. Allowable Emissions Comment (Description of Operating Method):	

**EMISSIONS UNIT INFORMATION**

Section [1] of [8]

**G. VISIBLE EMISSIONS INFORMATION**

**Complete Subsection G if this emissions unit is or would be subject to a unit-specific visible emissions limitation.**

**Visible Emissions Limitation:** Visible Emissions Limitation 1 of 1

1. Visible Emissions Subtype:	2. Basis for Allowable Opacity: <input checked="" type="checkbox"/> Rule <input type="checkbox"/> Other
3. Allowable Opacity: Normal Conditions: 5 % Exceptional Conditions: 100 % Maximum Period of Excess Opacity Allowed: 2 hours	
4. Method of Compliance: Compliance with opacity emission limits will be demonstrated annually using EPA Reference Method 22.	
5. Visible Emissions Comment: Excess emissions are allowed during startup, shutdown, or malfunction, provided that the best operational practices to minimize emissions are adhered to and the duration of these events does not exceed 2 hours in any 24-hour period (Rule 62-210.700(1), F.A.C.)	

**Visible Emissions Limitation:** Visible Emissions Limitation    of   

1. Visible Emissions Subtype:	2. Basis for Allowable Opacity: <input type="checkbox"/> Rule <input type="checkbox"/> Other
3. Allowable Opacity: Normal Conditions: % Exceptional Conditions: % Maximum Period of Excess Opacity Allowed: min/hour	
4. Method of Compliance:	
5. Visible Emissions Comment:	

**EMISSIONS UNIT INFORMATION**

Section [1] of [8]

**H. CONTINUOUS MONITOR INFORMATION**

**Complete Subsection H if this emissions unit is or would be subject to continuous monitoring.**

**Continuous Monitoring System:** Continuous Monitor \_\_\_ of \_\_\_

1. Parameter Code:	2. Pollutant(s):
3. CMS Requirement:	<input type="checkbox"/> Rule <input type="checkbox"/> Other
4. Monitor Information... Manufacturer: Model Number: Serial Number:	
5. Installation Date:	6. Performance Specification Test Date:
7. Continuous Monitor Comment:  <b>Not Applicable</b>	

**Continuous Monitoring System:** Continuous Monitor \_\_\_ of \_\_\_

1. Parameter Code:	2. Pollutant(s):
3. CMS Requirement:	<input type="checkbox"/> Rule <input type="checkbox"/> Other
4. Monitor Information... Manufacturer: Model Number: Serial Number:	
5. Installation Date:	6. Performance Specification Test Date:
7. Continuous Monitor Comment:	

**EMISSIONS UNIT INFORMATION**

Section [1] of [8]

**H. CONTINUOUS MONITOR INFORMATION (CONTINUED)**

**Continuous Monitoring System:** Continuous Monitor \_\_\_ of \_\_\_

1. Parameter Code:	2. Pollutant(s):
3. CMS Requirement:	<input type="checkbox"/> Rule <input type="checkbox"/> Other
4. Monitor Information... Manufacturer: Model Number: Serial Number:	
5. Installation Date:	6. Performance Specification Test Date:
7. Continuous Monitor Comment:  <b>Not Applicable</b>	

**Continuous Monitoring System:** Continuous Monitor \_\_\_ of \_\_\_

1. Parameter Code:	2. Pollutant(s):
3. CMS Requirement:	<input type="checkbox"/> Rule <input type="checkbox"/> Other
4. Monitor Information... Manufacturer: Model Number: Serial Number:	
5. Installation Date:	6. Performance Specification Test Date:
7. Continuous Monitor Comment:	

**EMISSIONS UNIT INFORMATION**

Section [1] of [8]

**I. EMISSIONS UNIT ADDITIONAL INFORMATION**

**Additional Requirements for All Applications, Except as Otherwise Stated**

1. Process Flow Diagram: (Required for all permit applications, except Title V air operation permit revision applications if this information was submitted to the department within the previous five years and would not be altered as a result of the revision being sought) <input checked="" type="checkbox"/> Attached, Document ID: <u>Appendix B</u> <input type="checkbox"/> Previously Submitted, Date _____
2. Fuel Analysis or Specification: (Required for all permit applications, except Title V air operation permit revision applications if this information was submitted to the department within the previous five years and would not be altered as a result of the revision being sought) <input checked="" type="checkbox"/> Attached, Document ID: <u>See Section 5</u> <input type="checkbox"/> Previously Submitted, Date _____
3. Detailed Description of Control Equipment: (Required for all permit applications, except Title V air operation permit revision applications if this information was submitted to the department within the previous five years and would not be altered as a result of the revision being sought) <input type="checkbox"/> Attached, Document ID: _____ <input checked="" type="checkbox"/> Previously Submitted, Date <u>December 2005</u>
4. Procedures for Startup and Shutdown: (Required for all operation permit applications, except Title V air operation permit revision applications if this information was submitted to the department within the previous five years and would not be altered as a result of the revision being sought) <input checked="" type="checkbox"/> Attached, Document ID: <u>Appendix C</u> <input type="checkbox"/> Previously Submitted, Date _____ <input type="checkbox"/> Not Applicable (construction application)
5. Operation and Maintenance Plan: (Required for all permit applications, except Title V air operation permit revision applications if this information was submitted to the department within the previous five years and would not be altered as a result of the revision being sought) <input checked="" type="checkbox"/> Attached, Document ID: <u>Appendix C</u> <input type="checkbox"/> Previously Submitted, Date _____ <input type="checkbox"/> Not Applicable
6. Compliance Demonstration Reports/Records: <input type="checkbox"/> Attached, Document ID: _____ Test Date(s)/Pollutant(s) Tested: _____ <input checked="" type="checkbox"/> Previously Submitted, Date: Test Date(s)/Pollutant(s) Tested: <u>FY 2010 compliance testing results and 2009 Statement of Compliance are included in Appendix D.</u> <input type="checkbox"/> To be Submitted, Date (if known): _____ Test Date(s)/Pollutant(s) Tested: _____ <input type="checkbox"/> Not Applicable Note: For FESOP applications, all required compliance demonstration records/reports must be submitted at the time of application. For Title V air operation permit applications, all required compliance demonstration reports/records must be submitted at the time of application, or a compliance plan must be submitted at the time of application.
7. Other Information Required by Rule or Statute: <input type="checkbox"/> Attached, Document ID: _____ <input checked="" type="checkbox"/> Not Applicable



**EMISSIONS UNIT INFORMATION**

Section [1] of [8]

**I. EMISSIONS UNIT ADDITIONAL INFORMATION (CONTINUED)**

**Additional Requirements for Air Construction Permit Applications**

1. Control Technology Review and Analysis (Rules 62-212.400(10) and 62-212.500(7), F.A.C.; 40 CFR 63.43(d) and (e)): <input type="checkbox"/> Attached, Document ID: _____ <input checked="" type="checkbox"/> Not Applicable
2. Good Engineering Practice Stack Height Analysis (Rules 62-212.400(4)(d) and 62-212.500(4)(f), F.A.C.): <input type="checkbox"/> Attached, Document ID: _____ <input checked="" type="checkbox"/> Not Applicable
3. Description of Stack Sampling Facilities: (Required for proposed new stack sampling facilities only) <input type="checkbox"/> Attached, Document ID: _____ <input checked="" type="checkbox"/> Not Applicable

**Additional Requirements for Title V Air Operation Permit Applications**

1. Identification of Applicable Requirements: <input checked="" type="checkbox"/> Attached, Document ID: <u>See Section 4</u>
2. Compliance Assurance Monitoring: <input type="checkbox"/> Attached, Document ID: _____ <input checked="" type="checkbox"/> Not Applicable <u>See Section 4</u>
3. Alternative Methods of Operation: <input type="checkbox"/> Attached, Document ID: _____ <input checked="" type="checkbox"/> Not Applicable
4. Alternative Modes of Operation (Emissions Trading): <input type="checkbox"/> Attached, Document ID: _____ <input checked="" type="checkbox"/> Not Applicable

**Additional Requirements Comment**

None
------

**EMISSIONS UNIT INFORMATION**

Section [2] of [8]

**A. GENERAL EMISSIONS UNIT INFORMATION**

**Title V Air Operation Permit Emissions Unit Classification**

1. Regulated or Unregulated Emissions Unit? (Check one, if applying for an initial, revised or renewal Title V air operation permit. Skip this item if applying for an air construction permit or FESOP only.)

- The emissions unit addressed in this Emissions Unit Information Section is a regulated emissions unit.
- The emissions unit addressed in this Emissions Unit Information Section is an unregulated emissions unit.

**Emissions Unit Description and Status**

1. Type of Emissions Unit Addressed in this Section: (Check one)

- This Emissions Unit Information Section addresses, as a single emissions unit, a single process or production unit, or activity, which produces one or more air pollutants and which has at least one definable emission point (stack or vent).
- This Emissions Unit Information Section addresses, as a single emissions unit, a group of process or production units and activities which has at least one definable emission point (stack or vent) but may also produce fugitive emissions.
- This Emissions Unit Information Section addresses, as a single emissions unit, one or more process or production units and activities which produce fugitive emissions only.

2. Description of Emissions Unit Addressed in this Section:

Pebble Lime Storage Silos

3. Emissions Unit Identification Number: 101

4. Emissions Unit Status Code: A	5. Commence Construction Date:	6. Initial Startup Date: 08/30/2001	7. Emissions Unit Major Group SIC Code: 49
-------------------------------------	--------------------------------	--	--

8. Federal Program Applicability: (Check all that apply)

- Acid Rain Unit **Not Applicable**
- CAIR Unit

9. Package Unit:

Manufacturer:

Model Number:

10. Generator Nameplate Rating: MW **Not Applicable**

11. Emissions Unit Comment:

Two (2) silos with common vent filter for storage of pebble lime used for acid gas control in SDA units.

**EMISSIONS UNIT INFORMATION**

Section [2] of [8]

**Emissions Unit Control Equipment/Method:** Control \_\_\_ of \_\_\_

1. Control Equipment/Method Description:  
This emissions unit is equipped with a fabric filter on the silo exhaust that activates only during silo loading operations.

2. Control Device or Method Code: 18

**Emissions Unit Control Equipment/Method:** Control \_\_\_ of \_\_\_

1. Control Equipment/Method Description:

2. Control Device or Method Code:

**Emissions Unit Control Equipment/Method:** Control \_\_\_ of \_\_\_

1. Control Equipment/Method Description:

2. Control Device or Method Code:

**Emissions Unit Control Equipment/Method:** Control \_\_\_ of \_\_\_

1. Control Equipment/Method Description:

2. Control Device or Method Code:

**EMISSIONS UNIT INFORMATION**

Section [2] of [8]

**B. EMISSIONS UNIT CAPACITY INFORMATION**

**(Optional for unregulated emissions units.)**

**Emissions Unit Operating Capacity and Schedule**

1. Maximum Process or Throughput Rate: 3,300 tons/year
2. Maximum Production Rate:
3. Maximum Heat Input Rate: million Btu/hr
4. Maximum Incineration Rate: pounds/hr tons/day
5. Requested Maximum Operating Schedule: hours/day days/week weeks/year 500 hours/year
6. Operating Capacity/Schedule Comment:  The vent filter serving the lime silos only activates (exhausts carrier air) during lime loading operations, which occur approximately 500 hours per year. The silos continuously feed lime to the slakers that serve the SDA units.

**EMISSIONS UNIT INFORMATION**

Section [2] of [8]

**C. EMISSION POINT (STACK/VENT) INFORMATION****(Optional for unregulated emissions units.)****Emission Point Description and Type**

1. Identification of Point on Plot Plan or Flow Diagram: See Appendix A		2. Emission Point Type Code: 2	
3. Descriptions of Emission Points Comprising this Emissions Unit for VE Tracking:  <b>Not Applicable</b>			
4. ID Numbers or Descriptions of Emission Units with this Emission Point in Common:  <b>Not Applicable</b>			
5. Discharge Type Code: P	6. Stack Height:		7. Exit Diameter:
8. Exit Temperature: °F <b>Ambient</b>	9. Actual Volumetric Flow Rate: acfm	10. Water Vapor: %	
11. Maximum Dry Standard Flow Rate: 1,200 dscfm		12. Nonstack Emission Point Height: feet	
13. Emission Point UTM Coordinates... Zone: 17 East (km): North (km):		14. Emission Point Latitude/Longitude... Latitude (DD/MM/SS) Longitude (DD/MM/SS)	
15. Emission Point Comment:  Two pebble lime storage silos exhaust through a common vent filter during silo loading operations.			

**EMISSIONS UNIT INFORMATION**

Section [2] of [8]

**D. SEGMENT (PROCESS/FUEL) INFORMATION**

**Segment Description and Rate:** Segment 1 of 2

1. Segment Description (Process/Fuel Type):		
2. Source Classification Code (SCC):		3. SCC Units: Tons transferred or handled
4. Maximum Hourly Rate:	5. Maximum Annual Rate:	6. Estimated Annual Activity Factor:
7. Maximum % Sulfur: N/A	8. Maximum % Ash: N/A	9. Million Btu per SCC Unit: N/A
10. Segment Comment:		

**Not Applicable**

**Segment Description and Rate:** Segment 2 of 2

1. Segment Description (Process/Fuel Type):		
2. Source Classification Code (SCC):		3. SCC Units:
4. Maximum Hourly Rate:	5. Maximum Annual Rate:	6. Estimated Annual Activity Factor:
7. Maximum % Sulfur:	8. Maximum % Ash:	9. Million Btu per SCC Unit:
10. Segment Comment:		

# EMISSIONS UNIT INFORMATION

Section [2] of [8]

## E. EMISSIONS UNIT POLLUTANTS

### List of Pollutants Emitted by Emissions Unit

1. Pollutant Emitted	2. Primary Control Device Code	3. Secondary Control Device Code	4. Pollutant Regulatory Code
PM	018		EL

**F1. EMISSIONS UNIT POLLUTANT DETAIL INFORMATION –  
POTENTIAL, FUGITIVE, AND ACTUAL EMISSIONS**

**(Optional for unregulated emissions units.)**

**Complete a Subsection F1 for each pollutant identified in Subsection E if applying for an air construction permit or concurrent processing of an air construction permit and a revised or renewal Title V operation permit. Complete for each emissions-limited pollutant identified in Subsection E if applying for an air operation permit.**

**Potential, Estimated Fugitive, and Baseline & Projected Actual Emissions**

1. Pollutant Emitted: PM		2. Total Percent Efficiency of Control:	
3. Potential Emissions: 0.36 lb/hour                                      tons/year		4. Synthetically Limited? <input type="checkbox"/> Yes <input checked="" type="checkbox"/> No	
5. Range of Estimated Fugitive Emissions. (as applicable): to tons/year			
6. Emission Factor: 0.015 grains/dscf  Reference:		7. Emissions Method Code: 5	
8.a. Baseline Actual Emissions (if required): tons/year		8.b. Baseline 24-month Period: From:                                      To:	
9.a. Projected Actual Emissions (if required): tons/year		9.b. Projected Monitoring Period: <input type="checkbox"/> 5 years <input type="checkbox"/> 10 years	
10. Calculation of Emissions:  Limited by Florida permit PSD-FL-086(B)			
11. Potential, Fugitive, and Actual Emissions Comment:  Limited by Florida permit PSD-FL-086(B)			



**F2. EMISSIONS UNIT POLLUTANT DETAIL INFORMATION -  
 ALLOWABLE EMISSIONS**

**Complete Subsection F2 if the pollutant identified in Subsection F1 is or would be subject to a numerical emissions limitation.**

**Allowable Emissions** Allowable Emissions 1 of 1

1. Basis for Allowable Emissions Code: RULE	2. Future Effective Date of Allowable Emissions:
3. Allowable Emissions and Units: 0.015 grains/dscf	4. Equivalent Allowable Emissions: 0.36 lb/hour                  tons/year
5. Method of Compliance: The emission unit has the potential to emit less than 100 tons per year and is equipped with a baghouse.	
6. Allowable Emissions Comment (Description of Operating Method): Limited By Florida permit PSD-FL-086(B)	

**Allowable Emissions** Allowable Emissions    of   

1. Basis for Allowable Emissions Code:	2. Future Effective Date of Allowable Emissions:
3. Allowable Emissions and Units:	4. Equivalent Allowable Emissions: lb/hour                  tons/year
5. Method of Compliance:	
6. Allowable Emissions Comment (Description of Operating Method):	

**Allowable Emissions** Allowable Emissions    of   

1. Basis for Allowable Emissions Code:	2. Future Effective Date of Allowable Emissions:
3. Allowable Emissions and Units:	4. Equivalent Allowable Emissions: lb/hour                  tons/year
5. Method of Compliance:	
6. Allowable Emissions Comment (Description of Operating Method):	

**EMISSIONS UNIT INFORMATION**

Section [2] of [8]

**G. VISIBLE EMISSIONS INFORMATION**

Complete Subsection G if this emissions unit is or would be subject to a unit-specific visible emissions limitation.

**Visible Emissions Limitation:** Visible Emissions Limitation 1 of 1

1. Visible Emissions Subtype: VE05	2. Basis for Allowable Opacity: <input checked="" type="checkbox"/> Rule <input type="checkbox"/> Other
3. Allowable Opacity: Normal Conditions: 5 % Exceptional Conditions: 100 % Maximum Period of Excess Opacity Allowed: 2 hours	
4. Method of Compliance: EPA Method 9 shall be used to determine opacity compliance pursuant to Chapter 62-297, F.A.C.	
5. Visible Emissions Comment: Excess emissions are allowed during startup, shutdown, or malfunction, provided that the best operational practices to minimize emissions are adhered to and the duration of these events does not exceed 2 hours in any 24-hour period (Rule 62-210.700(1), F.A.C.)	

**Visible Emissions Limitation:** Visible Emissions Limitation    of   

1. Visible Emissions Subtype:	2. Basis for Allowable Opacity: <input type="checkbox"/> Rule <input type="checkbox"/> Other
3. Allowable Opacity: Normal Conditions: % Exceptional Conditions: % Maximum Period of Excess Opacity Allowed: min/hour	
4. Method of Compliance:	
5. Visible Emissions Comment:	

**EMISSIONS UNIT INFORMATION**

Section [2] of [8]

**H. CONTINUOUS MONITOR INFORMATION**

**Complete Subsection H if this emissions unit is or would be subject to continuous monitoring.**

**Continuous Monitoring System:** Continuous Monitor \_\_\_ of \_\_\_

1. Parameter Code:	2. Pollutant(s):
3. CMS Requirement:	<input type="checkbox"/> Rule <input type="checkbox"/> Other
4. Monitor Information... Manufacturer: Model Number: Serial Number:	
5. Installation Date:	6. Performance Specification Test Date:
7. Continuous Monitor Comment:  <b>Not Applicable</b>	

**Continuous Monitoring System:** Continuous Monitor \_\_\_ of \_\_\_

1. Parameter Code:	2. Pollutant(s):
3. CMS Requirement:	<input type="checkbox"/> Rule <input type="checkbox"/> Other
4. Monitor Information... Manufacturer: Model Number: Serial Number:	
5. Installation Date:	6. Performance Specification Test Date:
7. Continuous Monitor Comment:	

**EMISSIONS UNIT INFORMATION**

Section [2] of [8]

**H. CONTINUOUS MONITOR INFORMATION (CONTINUED)**

**Continuous Monitoring System:** Continuous Monitor \_\_\_ of \_\_\_

1. Parameter Code:	2. Pollutant(s):
3. CMS Requirement:	<input type="checkbox"/> Rule <input type="checkbox"/> Other
4. Monitor Information... Manufacturer: Model Number: Serial Number:	
5. Installation Date:	6. Performance Specification Test Date:
7. Continuous Monitor Comment:  <b>Not Applicable</b>	

**Continuous Monitoring System:** Continuous Monitor \_\_\_ of \_\_\_

1. Parameter Code:	2. Pollutant(s):
3. CMS Requirement:	<input type="checkbox"/> Rule <input type="checkbox"/> Other
4. Monitor Information... Manufacturer: Model Number: Serial Number:	
5. Installation Date:	6. Performance Specification Test Date:
7. Continuous Monitor Comment:	

**EMISSIONS UNIT INFORMATION**

Section [2] of [8]

**I. EMISSIONS UNIT ADDITIONAL INFORMATION**

**Additional Requirements for All Applications, Except as Otherwise Stated**

1. Process Flow Diagram: (Required for all permit applications, except Title V air operation permit revision applications if this information was submitted to the department within the previous five years and would not be altered as a result of the revision being sought) <input checked="" type="checkbox"/> Attached, Document ID: <u>Appendix B</u> <input type="checkbox"/> Previously Submitted, Date _____
2. Fuel Analysis or Specification: (Required for all permit applications, except Title V air operation permit revision applications if this information was submitted to the department within the previous five years and would not be altered as a result of the revision being sought) <input checked="" type="checkbox"/> Attached, Document ID: <u>See Section 5</u> <input type="checkbox"/> Previously Submitted, Date _____
3. Detailed Description of Control Equipment: (Required for all permit applications, except Title V air operation permit revision applications if this information was submitted to the department within the previous five years and would not be altered as a result of the revision being sought) <input type="checkbox"/> Attached, Document ID: _____ <input checked="" type="checkbox"/> Previously Submitted, Date <u>December 2005</u>
4. Procedures for Startup and Shutdown: (Required for all operation permit applications, except Title V air operation permit revision applications if this information was submitted to the department within the previous five years and would not be altered as a result of the revision being sought) <input checked="" type="checkbox"/> Attached, Document ID: <u>Appendix C</u> <input type="checkbox"/> Previously Submitted, Date _____ <input type="checkbox"/> Not Applicable (construction application)
5. Operation and Maintenance Plan: (Required for all permit applications, except Title V air operation permit revision applications if this information was submitted to the department within the previous five years and would not be altered as a result of the revision being sought) <input checked="" type="checkbox"/> Attached, Document ID: <u>Appendix C</u> <input type="checkbox"/> Previously Submitted, Date _____ <input type="checkbox"/> Not Applicable
6. Compliance Demonstration Reports/Records: <input type="checkbox"/> Attached, Document ID: _____ Test Date(s)/Pollutant(s) Tested: _____ <input checked="" type="checkbox"/> Previously Submitted, Date: _ Test Date(s)/Pollutant(s) Tested: <u>FY 2010 compliance testing results and 2009 Statement of Compliance are included in Appendix D.</u> <input type="checkbox"/> To be Submitted, Date (if known): _____ Test Date(s)/Pollutant(s) Tested: _____ <input type="checkbox"/> Not Applicable Note: For FESOP applications, all required compliance demonstration records/reports must be submitted at the time of application. For Title V air operation permit applications, all required compliance demonstration reports/records must be submitted at the time of application, or a compliance plan must be submitted at the time of application.
7. Other Information Required by Rule or Statute: <input type="checkbox"/> Attached, Document ID: _____ <input checked="" type="checkbox"/> Not Applicable

**EMISSIONS UNIT INFORMATION**

Section [2] of [8]

**I. EMISSIONS UNIT ADDITIONAL INFORMATION (CONTINUED)**

**Additional Requirements for Air Construction Permit Applications**

1. Control Technology Review and Analysis (Rules 62-212.400(10) and 62-212.500(7), F.A.C.; 40 CFR 63.43(d) and (e)): <input type="checkbox"/> Attached, Document ID: _____ <input checked="" type="checkbox"/> Not Applicable
2. Good Engineering Practice Stack Height Analysis (Rules 62-212.400(4)(d) and 62-212.500(4)(f), F.A.C.): <input type="checkbox"/> Attached, Document ID: _____ <input checked="" type="checkbox"/> Not Applicable
3. Description of Stack Sampling Facilities: (Required for proposed new stack sampling facilities only) <input type="checkbox"/> Attached, Document ID: _____ <input checked="" type="checkbox"/> Not Applicable

**Additional Requirements for Title V Air Operation Permit Applications**

1. Identification of Applicable Requirements: <input checked="" type="checkbox"/> Attached, Document ID: <u>See Section 4</u>
2. Compliance Assurance Monitoring: <input type="checkbox"/> Attached, Document ID: _____ <input checked="" type="checkbox"/> Not Applicable <u>See Section 4</u>
3. Alternative Methods of Operation: <input type="checkbox"/> Attached, Document ID: _____ <input checked="" type="checkbox"/> Not Applicable
4. Alternative Modes of Operation (Emissions Trading): <input type="checkbox"/> Attached, Document ID: _____ <input checked="" type="checkbox"/> Not Applicable

**Additional Requirements Comment**

None
------

**EMISSIONS UNIT INFORMATION**

Section [3] of [8]

**A. GENERAL EMISSIONS UNIT INFORMATION**

**Title V Air Operation Permit Emissions Unit Classification**

1. Regulated or Unregulated Emissions Unit? (Check one, if applying for an initial, revised or renewal Title V air operation permit. Skip this item if applying for an air construction permit or FESOP only.)

The emissions unit addressed in this Emissions Unit Information Section is a regulated emissions unit.

The emissions unit addressed in this Emissions Unit Information Section is an unregulated emissions unit.

**Emissions Unit Description and Status**

1. Type of Emissions Unit Addressed in this Section: (Check one)

This Emissions Unit Information Section addresses, as a single emissions unit, a single process or production unit, or activity, which produces one or more air pollutants and which has at least one definable emission point (stack or vent).

This Emissions Unit Information Section addresses, as a single emissions unit, a group of process or production units and activities which has at least one definable emission point (stack or vent) but may also produce fugitive emissions.

This Emissions Unit Information Section addresses, as a single emissions unit, one or more process or production units and activities which produce fugitive emissions only.

2. Description of Emissions Unit Addressed in this Section:

Activated carbon storage silos

3. Emissions Unit Identification Number: 102

4. Emissions Unit Status Code: A	5. Commence Construction Date:	6. Initial Startup Date: 08/30/2001	7. Emissions Unit Major Group SIC Code: 49
-------------------------------------	--------------------------------	--	--

8. Federal Program Applicability: (Check all that apply)

Acid Rain Unit **Not Applicable**

CAIR Unit

9. Package Unit:  
Manufacturer: \_\_\_\_\_ Model Number: \_\_\_\_\_

10. Generator Nameplate Rating: MW **Not Applicable**

11. Emissions Unit Comment:  
Two (2) activated carbon storage silos used for mercury control in SDA units. Each silo is equipped with a vent filter that operates only during silo loading operations.

**EMISSIONS UNIT INFORMATION**

Section [3] of [8]

**Emissions Unit Control Equipment/Method:** Control 1 of 1

- |   |
|---|
| 1. Control Equipment/Method Description:<br>This emissions unit is equipped with a fabric filter on each silo exhaust that activates only during silo loading operations. |
| 2. Control Device or Method Code: 18  |

**Emissions Unit Control Equipment/Method:** Control \_\_\_ of \_\_\_

- |  |
|--|
| 1. Control Equipment/Method Description: |
| 2. Control Device or Method Code:        |

**Emissions Unit Control Equipment/Method:** Control \_\_\_ of \_\_\_

- |  |
|--|
| 1. Control Equipment/Method Description: |
| 2. Control Device or Method Code:        |

**Emissions Unit Control Equipment/Method:** Control \_\_\_ of \_\_\_

- |  |
|--|
| 1. Control Equipment/Method Description: |
| 2. Control Device or Method Code:        |



**EMISSIONS UNIT INFORMATION**

Section [3] of [8]

**B. EMISSIONS UNIT CAPACITY INFORMATION**

(Optional for unregulated emissions units.)

**Emissions Unit Operating Capacity and Schedule**

1. Maximum Process or Throughput Rate: 120 tons/year
2. Maximum Production Rate:
3. Maximum Heat Input Rate: million Btu/hr
4. Maximum Incineration Rate: pounds/hr tons/day
5. Requested Maximum Operating Schedule: hours/day days/week weeks/year 110 hours/year
6. Operating Capacity/Schedule Comment:  The vent filters serving the carbon silos only activate (exhaust carrier air) during carbon loading operations, which occur approximately 110 hours per year. The silos continuously feed activated carbon to the SDA units.

**EMISSIONS UNIT INFORMATION**

Section [3] of [8]

**C. EMISSION POINT (STACK/VENT) INFORMATION**

(Optional for unregulated emissions units.)

**Emission Point Description and Type**

1. Identification of Point on Plot Plan or Flow Diagram: See Appendix A		2. Emission Point Type Code: 2	
3. Descriptions of Emission Points Comprising this Emissions Unit for VE Tracking:  <b>Not Applicable</b>			
4. ID Numbers or Descriptions of Emission Units with this Emission Point in Common:  <b>Not Applicable</b>			
5. Discharge Type Code: P	6. Stack Height:		7. Exit Diameter:
8. Exit Temperature: °F <b>Ambient</b>	9. Actual Volumetric Flow Rate: acfm	10. Water Vapor: % <b>N/A</b>	
11. Maximum Dry Standard Flow Rate: 1,200 dscfm		12. Nonstack Emission Point Height: Feet	
13. Emission Point UTM Coordinates... Zone: 17 East (km): North (km):		14. Emission Point Latitude/Longitude... Latitude (DD/MM/SS) Longitude (DD/MM/SS)	
15. Emission Point Comment:  Each activated carbon storage silo exhausts through a vent filter during silo loading operations.			

**EMISSIONS UNIT INFORMATION**

Section [3] of [8]

**D. SEGMENT (PROCESS/FUEL) INFORMATION**

**Segment Description and Rate:** Segment 1 of 2

1. Segment Description (Process/Fuel Type):		
2. Source Classification Code (SCC):		
3. SCC Units:		
4. Maximum Hourly Rate:	5. Maximum Annual Rate:	6. Estimated Annual Activity Factor:
7. Maximum % Sulfur: N/A	8. Maximum % Ash: N/A	9. Million Btu per SCC Unit: N/A
10. Segment Comment:		

**Not Applicable**

**Segment Description and Rate:** Segment 2 of 2

1. Segment Description (Process/Fuel Type):		
2. Source Classification Code (SCC):		3. SCC Units:
4. Maximum Hourly Rate:	5. Maximum Annual Rate:	6. Estimated Annual Activity Factor:
7. Maximum % Sulfur:	8. Maximum % Ash:	9. Million Btu per SCC Unit:
10. Segment Comment:		

**EMISSIONS UNIT INFORMATION**

Section [3] of [8]

**E. EMISSIONS UNIT POLLUTANTS**

**List of Pollutants Emitted by Emissions Unit**

1. Pollutant Emitted	2. Primary Control Device Code	3. Secondary Control Device Code	4. Pollutant Regulatory Code
PM	018		EL

**F1. EMISSIONS UNIT POLLUTANT DETAIL INFORMATION –  
POTENTIAL, FUGITIVE, AND ACTUAL EMISSIONS  
(Optional for unregulated emissions units.)**

Complete a Subsection F1 for each pollutant identified in Subsection E if applying for an air construction permit or concurrent processing of an air construction permit and a revised or renewal Title V operation permit. Complete for each emissions-limited pollutant identified in Subsection E if applying for an air operation permit.

**Potential, Estimated Fugitive, and Baseline & Projected Actual Emissions**

1. Pollutant Emitted: PM		2. Total Percent Efficiency of Control:	
3. Potential Emissions: 0.36 lb/hour tons/year		4. Synthetically Limited? <input type="checkbox"/> Yes <input checked="" type="checkbox"/> No	
5. Range of Estimated Fugitive Emissions (as applicable): to tons/year			
6. Emission Factor: 0.015 grains/dscf Reference: PSD-FL-086(B)		7. Emissions Method Code: 5	
8.a. Baseline Actual Emissions (if required): tons/year		8.b. Baseline 24-month Period: From: To:	
9.a. Projected Actual Emissions (if required): tons/year		9.b. Projected Monitoring Period: <input type="checkbox"/> 5 years <input type="checkbox"/> 10 years	
10. Calculation of Emissions:  Limited by Florida permit PSD-FL-086(B)			
11. Potential, Fugitive, and Actual Emissions Comment:  Limited by Florida permit PSD-FL-086(B)			

**F2. EMISSIONS UNIT POLLUTANT DETAIL INFORMATION -  
 ALLOWABLE EMISSIONS**

**Complete Subsection F2 if the pollutant identified in Subsection F1 is or would be subject to a numerical emissions limitation.**

**Allowable Emissions** Allowable Emissions 1 of 1

1. Basis for Allowable Emissions Code: RULE	2. Future Effective Date of Allowable Emissions:
3. Allowable Emissions and Units: 0.015 grains/dscf	4. Equivalent Allowable Emissions: 0.36 lb/hour                  tons/year
5. Method of Compliance: This emission unit has the potential to emit less than 100 tons per year and is equipped with a baghouse.	
6. Allowable Emissions Comment (Description of Operating Method):  Limited by Florida permit PSD-FL-086(B)	

**Allowable Emissions** Allowable Emissions    of   

1. Basis for Allowable Emissions Code:	2. Future Effective Date of Allowable Emissions:
3. Allowable Emissions and Units:	4. Equivalent Allowable Emissions: lb/hour                  tons/year
5. Method of Compliance:	
6. Allowable Emissions Comment (Description of Operating Method):	

**Allowable Emissions** Allowable Emissions    of   

1. Basis for Allowable Emissions Code:	2. Future Effective Date of Allowable Emissions:
3. Allowable Emissions and Units:	4. Equivalent Allowable Emissions: lb/hour                  tons/year
5. Method of Compliance:	
6. Allowable Emissions Comment (Description of Operating Method):	

**EMISSIONS UNIT INFORMATION**

Section [3] of [8]

**G. VISIBLE EMISSIONS INFORMATION**

**Complete Subsection G if this emissions unit is or would be subject to a unit-specific visible emissions limitation.**

**Visible Emissions Limitation:** Visible Emissions Limitation 1 of 1

1. Visible Emissions Subtype: VE05	2. Basis for Allowable Opacity: <input checked="" type="checkbox"/> Rule <input type="checkbox"/> Other
3. Allowable Opacity: Normal Conditions: 5 % Exceptional Conditions: 100 % Maximum Period of Excess Opacity Allowed: 2 hours	
4. Method of Compliance: EPA Method 9 shall be used to determine opacity compliance pursuant to Chapter 6-297, F.A.C.	
5. Visible Emissions Comment: Excess emissions are allowed during startup, shutdown, or malfunction, provided that the best operational practices to minimize emissions are adhered to and the duration of these events does not exceed 2 hours in any 24-hour period (Rule 62-210.700(1), F.A.C.)	

**Visible Emissions Limitation:** Visible Emissions Limitation \_\_ of \_\_

1. Visible Emissions Subtype:	2. Basis for Allowable Opacity: <input type="checkbox"/> Rule <input type="checkbox"/> Other
3. Allowable Opacity: Normal Conditions: % Exceptional Conditions: % Maximum Period of Excess Opacity Allowed: min/hour	
4. Method of Compliance:	
5. Visible Emissions Comment:	

**EMISSIONS UNIT INFORMATION**

Section [3] of [8]

**H. CONTINUOUS MONITOR INFORMATION**

Complete Subsection H if this emissions unit is or would be subject to continuous monitoring.

**Continuous Monitoring System:** Continuous Monitor \_\_\_ of \_\_\_

1. Parameter Code:	2. Pollutant(s):
3. CMS Requirement:	<input type="checkbox"/> Rule <input type="checkbox"/> Other
4. Monitor Information... Manufacturer: Model Number: Serial Number:	
5. Installation Date:	6. Performance Specification Test Date:
7. Continuous Monitor Comment:  <b>Not Applicable</b>	

**Continuous Monitoring System:** Continuous Monitor \_\_\_ of \_\_\_

1. Parameter Code:	2. Pollutant(s):
3. CMS Requirement:	<input type="checkbox"/> Rule <input type="checkbox"/> Other
4. Monitor Information... Manufacturer: Model Number: Serial Number:	
5. Installation Date:	6. Performance Specification Test Date:
7. Continuous Monitor Comment:	



**EMISSIONS UNIT INFORMATION**

Section [3] of [8]

**H. CONTINUOUS MONITOR INFORMATION (CONTINUED)**

**Continuous Monitoring System:** Continuous Monitor \_\_\_ of \_\_\_

1. Parameter Code:	2. Pollutant(s):
3. CMS Requirement:	<input type="checkbox"/> Rule <input type="checkbox"/> Other
4. Monitor Information... Manufacturer: Model Number:	Serial Number:
5. Installation Date:	6. Performance Specification Test Date:
7. Continuous Monitor Comment:  <b>Not Applicable</b>	

**Continuous Monitoring System:** Continuous Monitor \_\_\_ of \_\_\_

1. Parameter Code:	2. Pollutant(s):
3. CMS Requirement:	<input type="checkbox"/> Rule <input type="checkbox"/> Other
4. Monitor Information... Manufacturer: Model Number:	Serial Number:
5. Installation Date:	6. Performance Specification Test Date:
7. Continuous Monitor Comment:	

**EMISSIONS UNIT INFORMATION**

Section [3] of [8]

**I. EMISSIONS UNIT ADDITIONAL INFORMATION**

**Additional Requirements for All Applications, Except as Otherwise Stated**

<p>1. Process Flow Diagram: (Required for all permit applications, except Title V air operation permit revision applications if this information was submitted to the department within the previous five years and would not be altered as a result of the revision being sought)</p> <p><input checked="" type="checkbox"/> Attached, Document ID: <u>Appendix B</u> <input type="checkbox"/> Previously Submitted, Date _____</p>
<p>2. Fuel Analysis or Specification: (Required for all permit applications, except Title V air operation permit revision applications if this information was submitted to the department within the previous five years and would not be altered as a result of the revision being sought)</p> <p><input checked="" type="checkbox"/> Attached, Document ID: <u>See Section 5</u> <input type="checkbox"/> Previously Submitted, Date _____</p>
<p>3. Detailed Description of Control Equipment: (Required for all permit applications, except Title V air operation permit revision applications if this information was submitted to the department within the previous five years and would not be altered as a result of the revision being sought)</p> <p><input type="checkbox"/> Attached, Document ID: _____ <input checked="" type="checkbox"/> Previously Submitted, Date <u>December 2005</u></p>
<p>4. Procedures for Startup and Shutdown: (Required for all operation permit applications, except Title V air operation permit revision applications if this information was submitted to the department within the previous five years and would not be altered as a result of the revision being sought)</p> <p><input checked="" type="checkbox"/> Attached, Document ID: <u>Appendix C</u> <input type="checkbox"/> Previously Submitted, Date _____</p> <p><input type="checkbox"/> Not Applicable (construction application)</p>
<p>5. Operation and Maintenance Plan: (Required for all permit applications, except Title V air operation permit revision applications if this information was submitted to the department within the previous five years and would not be altered as a result of the revision being sought)</p> <p><input checked="" type="checkbox"/> Attached, Document ID: <u>Appendix C</u> <input type="checkbox"/> Previously Submitted, Date _____</p> <p><input type="checkbox"/> Not Applicable</p>
<p>6. Compliance Demonstration Reports/Records:</p> <p><input type="checkbox"/> Attached, Document ID: _____</p> <p>Test Date(s)/Pollutant(s) Tested: _____</p> <p><input checked="" type="checkbox"/> Previously Submitted, Date: _____</p> <p>Test Date(s)/Pollutant(s) Tested: <u>FY 2010 compliance testing results and 2009 Statement of Compliance are included in Appendix D.</u></p> <p><input type="checkbox"/> To be Submitted, Date (if known): _____</p> <p>Test Date(s)/Pollutant(s) Tested: _____</p> <p><input type="checkbox"/> Not Applicable</p> <p>Note: For FESOP applications, all required compliance demonstration records/reports must be submitted at the time of application. For Title V air operation permit applications, all required compliance demonstration reports/records must be submitted at the time of application, or a compliance plan must be submitted at the time of application.</p>
<p>7. Other Information Required by Rule or Statute:</p> <p><input type="checkbox"/> Attached, Document ID: _____ <input checked="" type="checkbox"/> Not Applicable</p>

**EMISSIONS UNIT INFORMATION**

Section [3] of [8]

**I. EMISSIONS UNIT ADDITIONAL INFORMATION (CONTINUED)**

**Additional Requirements for Air Construction Permit Applications**

1. Control Technology Review and Analysis (Rules 62-212.400(10) and 62-212.500(7), F.A.C.; 40 CFR 63.43(d) and (e)): <input type="checkbox"/> Attached, Document ID: _____ <input checked="" type="checkbox"/> Not Applicable
2. Good Engineering Practice Stack Height Analysis (Rules 62-212.400(4)(d) and 62-212.500(4)(f), F.A.C.): <input type="checkbox"/> Attached, Document ID: _____ <input checked="" type="checkbox"/> Not Applicable
3. Description of Stack Sampling Facilities: (Required for proposed new stack sampling facilities only) <input type="checkbox"/> Attached, Document ID: _____ <input checked="" type="checkbox"/> Not Applicable

**Additional Requirements for Title V Air Operation Permit Applications**

1. Identification of Applicable Requirements: <input checked="" type="checkbox"/> Attached, Document ID: <u>See Section 4</u>
2. Compliance Assurance Monitoring: <input type="checkbox"/> Attached, Document ID: _____ <input checked="" type="checkbox"/> Not Applicable <u>See Section 4</u>
3. Alternative Methods of Operation: <input type="checkbox"/> Attached, Document ID: _____ <input checked="" type="checkbox"/> Not Applicable
4. Alternative Modes of Operation (Emissions Trading): <input type="checkbox"/> Attached, Document ID: _____ <input checked="" type="checkbox"/> Not Applicable

**Additional Requirements Comment**

None
------

# EMISSIONS UNIT INFORMATION

Section [4] of [8]

## A. GENERAL EMISSIONS UNIT INFORMATION

### Title V Air Operation Permit Emissions Unit Classification

1. Regulated or Unregulated Emissions Unit? (Check one, if applying for an initial, revised or renewal Title V air operation permit. Skip this item if applying for an air construction permit or FESOP only.)

The emissions unit addressed in this Emissions Unit Information Section is a regulated emissions unit.

The emissions unit addressed in this Emissions Unit Information Section is an unregulated emissions unit.

### Emissions Unit Description and Status

1. Type of Emissions Unit Addressed in this Section: (Check one)

This Emissions Unit Information Section addresses, as a single emissions unit, a single process or production unit, or activity, which produces one or more air pollutants and which has at least one definable emission point (stack or vent).

This Emissions Unit Information Section addresses, as a single emissions unit, a group of process or production units and activities which has at least one definable emission point (stack or vent) but may also produce fugitive emissions.

This Emissions Unit Information Section addresses, as a single emissions unit, one or more process or production units and activities which produce fugitive emissions only.

2. Description of Emissions Unit Addressed in this Section:

Municipal Waste Combustors and Auxiliary Burners – Unit No. 1

3. Emissions Unit Identification Number: 103

4. Emissions Unit Status Code:  
A

5. Commence Construction Date:

6. Initial Startup Date:  
08/30/2001

7. Emissions Unit Major Group SIC Code: 49

8. Federal Program Applicability: (Check all that apply)

Acid Rain Unit **Not Applicable**

CAIR Unit

9. Package Unit:

Manufacturer: D.B. Riley

Model Number: 2753

10. Generator Nameplate Rating: 22.5 MW

11. Emissions Unit Comment:

Excess emissions are allowed during startup, shutdown, or malfunction, provided that the duration of these events does not exceed 3 hours per occurrence. For CO compliance, the duration of a malfunction period is limited to 15 hours per.

**EMISSIONS UNIT INFORMATION**

Section [4] of [8]

**Emissions Unit Control Equipment/Method:** Control 1 of 1

- |  |
|--|
| 1. Control Equipment/Method Description:<br>This emissions unit equipped with a spray dryer absorber (SDA), activated carbon injection system, fabric filter baghouse, and selective non-catalytic reduction (SNCR). |
| 2. Control Device or Method Code: 016, 048, 067, 107   |

**Emissions Unit Control Equipment/Method:** Control \_\_\_ of \_\_\_

- |  |
|--|
| 1. Control Equipment/Method Description: |
| 2. Control Device or Method Code:        |

**Emissions Unit Control Equipment/Method:** Control \_\_\_ of \_\_\_

- |  |
|--|
| 1. Control Equipment/Method Description: |
| 2. Control Device or Method Code:        |

**Emissions Unit Control Equipment/Method:** Control \_\_\_ of \_\_\_

- |  |
|--|
| 1. Control Equipment/Method Description: |
| 2. Control Device or Method Code:        |

**EMISSIONS UNIT INFORMATION**

Section [4] of [8]

**B. EMISSIONS UNIT CAPACITY INFORMATION**

(Optional for unregulated emissions units.)

**Emissions Unit Operating Capacity and Schedule**

1. Maximum Process or Throughput Rate:
2. Maximum Production Rate:
3. Maximum Heat Input Rate: million 120 MMBtu/hr (see item 6)
4. Maximum Incineration Rate: pounds/hr 288 tons/day
5. Requested Maximum Operating Schedule: 24 hours/day 7 days/week 52 weeks/year 8,760 hours/year
6. Operating Capacity/Schedule Comment:  120 MMBtu/hour heat input rate for information purposes only, not for compliance. Maximum steam flow and nominal capacity are limited by Florida permit PSD-FL-086(B).

**EMISSIONS UNIT INFORMATION**

Section [4] of [8]

**C. EMISSION POINT (STACK/VENT) INFORMATION**

**(Optional for unregulated emissions units.)**

**Emission Point Description and Type**

1. Identification of Point on Plot Plan or Flow Diagram: See Appendix A		2. Emission Point Type Code: 1	
3. Descriptions of Emission Points Comprising this Emissions Unit for VE Tracking:  <b>Not Applicable</b>			
4. ID Numbers or Descriptions of Emission Units with this Emission Point in Common:  <b>Not Applicable</b>			
5. Discharge Type Code: V	6. Stack Height: 201 feet	7. Exit Diameter: 4.2 feet	
8. Exit Temperature: 315 °F	9. Actual Volumetric Flow Rate: 60,894 acfm	10. Water Vapor: 20 % ±	
11. Maximum Dry Standard Flow Rate: 36,686 dscfm		12. Nonstack Emission Point Height: Feet	
13. Emission Point UTM Coordinates... Zone: 17 East (km): 360.0 North (km): 3091.0		14. Emission Point Latitude/Longitude... Latitude (DD/MM/SS) Longitude (DD/MM/SS)	
15. Emission Point Comment:  Four MWCs have separate stacks (flues) located within a common enclosure.			

**EMISSIONS UNIT INFORMATION**

Section [4] of [8]

**D. SEGMENT (PROCESS/FUEL) INFORMATION**

**Segment Description and Rate:** Segment 1 of 2

1. Segment Description (Process/Fuel Type):  Solid Waste Disposal – Government Municipal Incineration – Stationary Mass Burn Waterwall Combustor		
2. Source Classification Code (SCC): 50100105		3. SCC Units: Tons burned (all solid fuels)
4. Maximum Hourly Rate: See item 10	5. Maximum Annual Rate: See item 10	6. Estimated Annual Activity Factor:
7. Maximum % Sulfur: N/A	8. Maximum % Ash: N/A	9. Million Btu per SCC Unit: <b>10 ±</b>
10. Segment Comment:  PSD-FL-086(B) limits nominal heat input to 104 MMBtu/hr and nominal capacity to 250 tons per day (rolling 12-month average).		

**Segment Description and Rate:** Segment 2 of 2

1. Segment Description (Process/Fuel Type):  Solid Waste Disposal – Government Auxiliary Fuel/No Emissions – Natural Gas		
2. Source Classification Code (SCC): 50100106		3. SCC Units: Million Cubic Feet Burned (all gaseous fuels)
4. Maximum Hourly Rate: See item 10	5. Maximum Annual Rate: See item 10	6. Estimated Annual Activity Factor:
7. Maximum % Sulfur:	8. Maximum % Ash:	9. Million Btu per SCC Unit: 1027 ±
10. Segment Comment:  PSD-FL-086(B) limits the maximum hourly rate by the 10% annual capacity factor.		



**EMISSIONS UNIT INFORMATION**

Section [4] of [8]

**E. EMISSIONS UNIT POLLUTANTS**

**List of Pollutants Emitted by Emissions Unit**

1. Pollutant Emitted	2. Primary Control Device Code	3. Secondary Control Device Code	4. Pollutant Regulatory Code
PM	016		EL
SO2	067	016	EL
NOx	107		EL
CO			EL
HCL (H106)	067	016	EL
H107	016		EL
PB	016		EL
H021	016		EL
H114	048		EL
DIOX	067	016	EL
H027	016		EL

**F1. EMISSIONS UNIT POLLUTANT DETAIL INFORMATION –  
 POTENTIAL, FUGITIVE, AND ACTUAL EMISSIONS**  
 (Optional for unregulated emissions units.)

**Complete a Subsection F1 for each pollutant identified in Subsection E if applying for an air construction permit or concurrent processing of an air construction permit and a revised or renewal Title V operation permit. Complete for each emissions-limited pollutant identified in Subsection E if applying for an air operation permit.**

**Potential, Estimated Fugitive, and Baseline & Projected Actual Emissions**

1. Pollutant Emitted: PM		2. Total Percent Efficiency of Control:	
3. Potential Emissions: 2.76 lb/hour tons/year		4. Synthetically Limited? <input type="checkbox"/> Yes <input checked="" type="checkbox"/> No	
5. Range of Estimated Fugitive Emissions (as applicable): to tons/year			
6. Emission Factor: 25 mg/dscm, corrected to 7% O <sub>2</sub> Reference: Revised 40 CFR 60 Subpart Cb		7. Emissions Method Code: 0	
8.a. Baseline Actual Emissions (if required): tons/year		8.b. Baseline 24-month Period: From: To:	
9.a. Projected Actual Emissions (if required): tons/year		9.b. Projected Monitoring Period: <input type="checkbox"/> 5 years <input type="checkbox"/> 10 years	
10. Calculation of Emissions:  Limited by Florida permit PSD-FL-086(B) and revised 40 CFR 60 Subpart Cb.			
11. Potential, Fugitive, and Actual Emissions Comment:  Limited by Florida permit PSD-FL-086(B). The current permitted emission limit for PM is 27mg/dscm and the revised 40 CFR 60 Subpart Cb limit is 25 mg/dscm.			



**F1. EMISSIONS UNIT POLLUTANT DETAIL INFORMATION –  
POTENTIAL, FUGITIVE, AND ACTUAL EMISSIONS  
(Optional for unregulated emissions units.)**

**Complete a Subsection F1 for each pollutant identified in Subsection E if applying for an air construction permit or concurrent processing of an air construction permit and a revised or renewal Title V operation permit. Complete for each emissions-limited pollutant identified in Subsection E if applying for an air operation permit.**

**Potential, Estimated Fugitive, and Baseline & Projected Actual Emissions**

1. Pollutant Emitted: NOx		2. Total Percent Efficiency of Control:	
3. Potential Emissions: 40.1 lb/hour		tons/year	4. Synthetically Limited? <input type="checkbox"/> Yes <input checked="" type="checkbox"/> No
5. Range of Estimated Fugitive Emissions (as applicable): to tons/year			
6. Emission Factor: 205 ppmvd, corrected to 7% O2 Reference: PSD-FL-086(B)		7. Emissions Method Code: 0	
8.a. Baseline Actual Emissions (if required): tons/year		8.b. Baseline 24-month Period: From: To:	
9.a. Projected Actual Emissions (if required): tons/year		9.b. Projected Monitoring Period: <input type="checkbox"/> 5 years <input type="checkbox"/> 10 years	
10. Calculation of Emissions:  Limited by Florida permit PSD-FL-086(B)			
11. Potential, Fugitive, and Actual Emissions Comment:  Limited by Florida permit PSD-FL-086(B), which also contains additional emission limit of 0.335 lb/MMBtu. Facility-wide NOx emission limited to 679 tons/year.			

**F1. EMISSIONS UNIT POLLUTANT DETAIL INFORMATION –  
 POTENTIAL, FUGITIVE, AND ACTUAL EMISSIONS**  
 (Optional for unregulated emissions units.)

Complete a Subsection F1 for each pollutant identified in Subsection E if applying for an air construction permit or concurrent processing of an air construction permit and a revised or renewal Title V operation permit. Complete for each emissions-limited pollutant identified in Subsection E if applying for an air operation permit.

**Potential, Estimated Fugitive, and Baseline & Projected Actual Emissions**

1. Pollutant Emitted: CO		2. Total Percent Efficiency of Control:	
3. Potential Emissions: 11.91 lb/hour                      tons/year		4. Synthetically Limited? <input type="checkbox"/> Yes <input checked="" type="checkbox"/> No	
5. Range of Estimated Fugitive Emissions (as applicable): to tons/year			
6. Emission Factor: 100 ppmvd, corrected to 7% O2 Reference: PSD-FL-086(B)		7. Emissions Method Code: 0	
8.a. Baseline Actual Emissions (if required): tons/year		8.b. Baseline 24-month Period: From:                      To:	
9.a. Projected Actual Emissions (if required): tons/year		9.b. Projected Monitoring Period: <input type="checkbox"/> 5 years <input type="checkbox"/> 10 years	
10. Calculation of Emissions:  Limited by Florida permit PSD-FL-086(B)			
11. Potential, Fugitive, and Actual Emissions Comment:  Limited by Florida permit PSD-FL-086(B), which also contains additional emission limit of 0.0995 lb/MMBtu. Facility-wide CO emission limited to 185 tons/year.			

F1. EMISSIONS UNIT POLLUTANT DETAIL INFORMATION –  
POTENTIAL, FUGITIVE, AND ACTUAL EMISSIONS  
(Optional for unregulated emissions units.)

Complete a Subsection F1 for each pollutant identified in Subsection E if applying for an air construction permit or concurrent processing of an air construction permit and a revised or renewal Title V operation permit. Complete for each emissions-limited pollutant identified in Subsection E if applying for an air operation permit.

Potential, Estimated Fugitive, and Baseline & Projected Actual Emissions

1. Pollutant Emitted: HCL (H106)		2. Total Percent Efficiency of Control:	
3. Potential Emissions: lb/hour 67.9 tons/year		4. Synthetically Limited? <input type="checkbox"/> Yes <input checked="checked" type="checkbox"/> No	
5. Range of Estimated Fugitive Emissions (as applicable): to tons/year			
6. Emission Factor: 29 ppmvd or 95% removal, corrected to 7% O2 Reference: PSD-FL-086(B)		7. Emissions Method Code: 0	
8.a. Baseline Actual Emissions (if required): tons/year		8.b. Baseline 24-month Period: From: To:	
9.a. Projected Actual Emissions (if required): tons/year		9.b. Projected Monitoring Period: <input type="checkbox"/> 5 years <input type="checkbox"/> 10 years	
10. Calculation of Emissions:  Limited by Florida permit PSD-FL-086(B)			
11. Potential, Fugitive, and Actual Emissions Comment:  Limited by Florida permit PSD-FL-086(B) limits HCL emissions to 29 ppmvd or 5% of the potential sulfur dioxide emission (95% reduction by weight or volume), corrected to 7% O2, whichever is less stringent.			

**F1. EMISSIONS UNIT POLLUTANT DETAIL INFORMATION –  
 POTENTIAL, FUGITIVE, AND ACTUAL EMISSIONS**  
 (Optional for unregulated emissions units.)

Complete a Subsection F1 for each pollutant identified in Subsection E if applying for an air construction permit or concurrent processing of an air construction permit and a revised or renewal Title V operation permit. Complete for each emissions-limited pollutant identified in Subsection E if applying for an air operation permit.

**Potential, Estimated Fugitive, and Baseline & Projected Actual Emissions**

1. Pollutant Emitted: H107 (Fluoride as HF)		2. Total Percent Efficiency of Control:	
3. Potential Emissions: 1.5 lb/hour                      6.57 tons/year		4. Synthetically Limited? <input type="checkbox"/> Yes <input checked="" type="checkbox"/> No	
5. Range of Estimated Fugitive Emissions (as applicable): to tons/year			
6. Emission Factor: Reference: PSD-FL-086(B)		7. Emissions Method Code: 0	
8.a. Baseline Actual Emissions (if required): tons/year		8.b. Baseline 24-month Period: From:                      To:	
9.a. Projected Actual Emissions (if required): tons/year		9.b. Projected Monitoring Period: <input type="checkbox"/> 5 years <input type="checkbox"/> 10 years	
10. Calculation of Emissions:  Limited by Florida permit PSD-FL-086(B)			
11. Potential, Fugitive, and Actual Emissions Comment:  Limited by Florida permit PSD-FL-086(B), which also contains additional emission limit of 0.0125 lb/MMBtu.			

**F1. EMISSIONS UNIT POLLUTANT DETAIL INFORMATION –  
 POTENTIAL, FUGITIVE, AND ACTUAL EMISSIONS**  
 (Optional for unregulated emissions units.)

Complete a Subsection F1 for each pollutant identified in Subsection E if applying for an air construction permit or concurrent processing of an air construction permit and a revised or renewal Title V operation permit. Complete for each emissions-limited pollutant identified in Subsection E if applying for an air operation permit.

**Potential, Estimated Fugitive, and Baseline & Projected Actual Emissions**

1. Pollutant Emitted: PB		2. Total Percent Efficiency of Control:	
3. Potential Emissions: 0.0451 lb/hour      0.197 tons/year		4. Synthetically Limited? <input type="checkbox"/> Yes <input checked="" type="checkbox"/> No	
5. Range of Estimated Fugitive Emissions (as applicable): to tons/year			
6. Emission Factor: 0.40 mg/dscm, corrected to 7% O2 Reference: Revised 40 CFR 60 Subpart Cb		7. Emissions Method Code: 0	
8.a. Baseline Actual Emissions (if required): tons/year		8.b. Baseline 24-month Period: From:                      To:	
9.a. Projected Actual Emissions (if required): tons/year		9.b. Projected Monitoring Period: <input type="checkbox"/> 5 years <input type="checkbox"/> 10 years	
10. Calculation of Emissions:  Limited by Florida permit PSD-FL-086(B) and revised 40 CFR 60 Subpart Cb			
11. Potential, Fugitive, and Actual Emissions Comment:  Limited by Florida permit PSD-FL-086(B), which also contains additional emission limit of 3.76E-04 lb/MMBtu. The current permitted emission limit for lead is 0.44 mg/dscm and the revised 40 CFR 60 Subpart Cb limit is 0.40 mg/dscm.			



**F1. EMISSIONS UNIT POLLUTANT DETAIL INFORMATION –  
 POTENTIAL, FUGITIVE, AND ACTUAL EMISSIONS**  
 (Optional for unregulated emissions units.)

**Complete a Subsection F1 for each pollutant identified in Subsection E if applying for an air construction permit or concurrent processing of an air construction permit and a revised or renewal Title V operation permit. Complete for each emissions-limited pollutant identified in Subsection E if applying for an air operation permit.**

**Potential, Estimated Fugitive, and Baseline & Projected Actual Emissions**

1. Pollutant Emitted: H021 (Beryllium Compounds)		2. Total Percent Efficiency of Control:	
3. Potential Emissions: 0.000115 lb/hour 5.04E-04 tons/year		4. Synthetically Limited? <input type="checkbox"/> Yes <input checked="" type="checkbox"/> No	
5. Range of Estimated Fugitive Emissions (as applicable): to tons/year			
6. Emission Factor:  Reference: PSD-FL-086(B)		7. Emissions Method Code: 0	
8.a. Baseline Actual Emissions (if required): tons/year		8.b. Baseline 24-month Period: From: To:	
9.a. Projected Actual Emissions (if required): tons/year		9.b. Projected Monitoring Period: <input type="checkbox"/> 5 years <input type="checkbox"/> 10 years	
10. Calculation of Emissions:  Limited by Florida permit PSD-FL-086(B)			
11. Potential, Fugitive, and Actual Emissions Comment:  Limited by Florida permit PSD-FL-086(B), which also contains additional emission limit of 9.58E-07 lb/MMBtu.			

**F1. EMISSIONS UNIT POLLUTANT DETAIL INFORMATION –  
 POTENTIAL, FUGITIVE, AND ACTUAL EMISSIONS**  
 (Optional for unregulated emissions units.)

Complete a Subsection F1 for each pollutant identified in Subsection E if applying for an air construction permit or concurrent processing of an air construction permit and a revised or renewal Title V operation permit. Complete for each emissions-limited pollutant identified in Subsection E if applying for an air operation permit.

**Potential, Estimated Fugitive, and Baseline & Projected Actual Emissions**

1. Pollutant Emitted: H114 (Mercury Compounds)	2. Total Percent Efficiency of Control:
3. Potential Emissions: lb/hour 0.0605 tons/year	4. Synthetically Limited? <input type="checkbox"/> Yes <input checked="checked" type="checkbox"/> No
5. Range of Estimated Fugitive Emissions (as applicable): to tons/year	
6. Emission Factor: 0.050 mg/dscm or 85% reduction, corrected to 7% O2  Reference: Revised 40 CFR 60 Subpart Cb	7. Emissions Method Code: 0
8.a. Baseline Actual Emissions (if required): tons/year	8.b. Baseline 24-month Period: From: To:
9.a. Projected Actual Emissions (if required): tons/year	9.b. Projected Monitoring Period: <input type="checkbox"/> 5 years <input type="checkbox"/> 10 years
10. Calculation of Emissions:  Limited by Florida permit PSD-FL-086(B) and revised 40 CFR 60 Subpart Cb	
11. Potential, Fugitive, and Actual Emissions Comment: Limited by Florida permit PSD-FL-086(B) limits H114 emissions to 0.070 mg/dscm or 15% of the potential mercury emission concentration (85% reduction by weight or volume), corrected to 7% O2, whichever is less stringent. The current permitted emission limit for mercury is 0.070 mg/dscm and the revised 40 CFR 60 Subpart Cb limit is 0.050 mg/dscm.	

**F1. EMISSIONS UNIT POLLUTANT DETAIL INFORMATION –  
POTENTIAL, FUGITIVE, AND ACTUAL EMISSIONS**  
(Optional for unregulated emissions units.)

Complete a Subsection F1 for each pollutant identified in Subsection E if applying for an air construction permit or concurrent processing of an air construction permit and a revised or renewal Title V operation permit. Complete for each emissions-limited pollutant identified in Subsection E if applying for an air operation permit.

**Potential, Estimated Fugitive, and Baseline & Projected Actual Emissions**

1. Pollutant Emitted: DIOX		2. Total Percent Efficiency of Control:	
3. Potential Emissions: 3.07E-06 lb/hour 1.35E-05 tons/year		4. Synthetically Limited? <input type="checkbox"/> Yes <input checked="" type="checkbox"/> No	
5. Range of Estimated Fugitive Emissions (as applicable): to tons/year			
6. Emission Factor: 30 ng/dscm (total mass), corrected to 7% O2 Reference: PSD-FL-086(B)		7. Emissions Method Code: 0	
8.a. Baseline Actual Emissions (if required): tons/year		8.b. Baseline 24-month Period: From: To:	
9.a. Projected Actual Emissions (if required): tons/year		9.b. Projected Monitoring Period: <input type="checkbox"/> 5 years <input type="checkbox"/> 10 years	
10. Calculation of Emissions:  Limited by Florida permit PSD-FL-086(B)			
11. Potential, Fugitive, and Actual Emissions Comment:  Limited by Florida permit PSD-FL-086(B), which also contains additional emission limit of 2.56E-08 lb/MMBtu.			

**F1. EMISSIONS UNIT POLLUTANT DETAIL INFORMATION –  
 POTENTIAL, FUGITIVE, AND ACTUAL EMISSIONS**  
 (Optional for unregulated emissions units.)

**Complete a Subsection F1 for each pollutant identified in Subsection E if applying for an air construction permit or concurrent processing of an air construction permit and a revised or renewal Title V operation permit. Complete for each emissions-limited pollutant identified in Subsection E if applying for an air operation permit.**

**Potential, Estimated Fugitive, and Baseline & Projected Actual Emissions**

1. Pollutant Emitted: H027 (Cadmium Compounds)		2. Total Percent Efficiency of Control:	
3. Potential Emissions: 4.10E-03 lb/hour    0.0179 tons/year		4. Synthetically Limited? <input type="checkbox"/> Yes <input checked="" type="checkbox"/> No	
5. Range of Estimated Fugitive Emissions (as applicable): to tons/year			
6. Emission Factor: 0.035 mg/dscm, corrected to 7% O2 Reference: Revised 40 CFR 60 Subpart Cb		7. Emissions Method Code: 0	
8.a. Baseline Actual Emissions (if required): tons/year		8.b. Baseline 24-month Period: From:                                  To:	
9.a. Projected Actual Emissions (if required): tons/year		9.b. Projected Monitoring Period: <input type="checkbox"/> 5 years <input type="checkbox"/> 10 years	
10. Calculation of Emissions:  Limited by Florida permit PSD-FL-086(B) and revised 40 CFR 60 Subpart Cb.			
11. Potential, Fugitive, and Actual Emissions Comment:  Limited by Florida permit PSD-FL-086(B), which also contains additional emission limit of 3.24E-05 lb/MMBtu. The current permitted emission limit for cadmium is 0.040 mg/dscm and the revised 40 CFR 60 Subpart Cb limit is 0.035 mg/dscm.			

**F2. EMISSIONS UNIT POLLUTANT DETAIL INFORMATION -  
 ALLOWABLE EMISSIONS**

**Complete Subsection F2 if the pollutant identified in Subsection F1 is or would be subject to a numerical emissions limitation.**

**Allowable Emissions** Allowable Emissions 1 of 11

1. Basis for Allowable Emissions Code: RULE	2. Future Effective Date of Allowable Emissions:
3. Allowable Emissions and Units: 25 mg/dscm, corrected to 7% O2	4. Equivalent Allowable Emissions: 2.76 lb/hour      12.1 tons/year
5. Method of Compliance: Compliance with PM emission limits will be demonstrated annually using EPA Reference Method 5.	
6. Allowable Emissions Comment (Description of Operating Method): Limited by Florida permit PSD-FL-086(B). The revised 40 CFR 60 Subpart Cb limit for PM is 25 mg/dscm.	

**Allowable Emissions** Allowable Emissions 2 of 11

1. Basis for Allowable Emissions Code: RULE	2. Future Effective Date of Allowable Emissions:
3. Allowable Emissions and Units: 29 ppmvd or 85% reduction, corrected to 7% O2	4. Equivalent Allowable Emissions: lb/hour      tons/year
5. Method of Compliance: Compliance with SO2 emission limits will be demonstrated via CEMS using EPA Reference Method 19 to calculate the daily geometric average SO2 concentration.	
6. Allowable Emissions Comment (Description of Operating Method): Florida permit PSD-FL-086(B) limits SO2 emissions to 29 ppmvd or 25% of the potential sulfur dioxide emission (75% reduction by weight or volume), corrected to 7% O2, whichever is less stringent. Facility-wide SO2 emission limited to 460 tons/year.	

**Allowable Emissions** Allowable Emissions 3 of 11

1. Basis for Allowable Emissions Code: RULE	2. Future Effective Date of Allowable Emissions:
3. Allowable Emissions and Units: 205 ppmvd, corrected to 7% O2	4. Equivalent Allowable Emissions: 40.1 lb/hour      tons/year
5. Method of Compliance: Compliance with NOx emission limits will be demonstrated via CEMS using EPA Reference Method 19 to calculate the daily arithmetic average NOx concentration.	
6. Allowable Emissions Comment (Description of Operating Method): Limited by Florida permit PSD-FL-086(B). Facility-wide NOx emissions limited to 679 tons/year.	

**F2. EMISSIONS UNIT POLLUTANT DETAIL INFORMATION -  
ALLOWABLE EMISSIONS**

**Complete Subsection F2 if the pollutant identified in Subsection F1 is or would be subject to a numerical emissions limitation.**

**Allowable Emissions** Allowable Emissions 4 of 11

1. Basis for Allowable Emissions Code: RULE	2. Future Effective Date of Allowable Emissions:
3. Allowable Emissions and Units: 100 ppmvd, corrected to 7% O2	4. Equivalent Allowable Emissions: 11.9 lb/hour          tons/year
5. Method of Compliance: Compliance with CO emission limits will be demonstrated via CEMS using a 4-hour block average.	
6. Allowable Emissions Comment (Description of Operating Method): Limited by Florida permit PSD-FL-086(B). Facility-wide CO emissions limited to 185 tons/year.	

**Allowable Emissions** Allowable Emissions 5 of 11

1. Basis for Allowable Emissions Code: RULE	2. Future Effective Date of Allowable Emissions:
3. Allowable Emissions and Units: 29 ppmvd or 95% removal, corrected to 7% O2	4. Equivalent Allowable Emissions: lb/hour          67.9 tons/year
5. Method of Compliance: Compliance with HCL emission limits will be demonstrated annually using EPA Reference Method 26 or 26A.	
6. Allowable Emissions Comment (Description of Operating Method): Florida permit PSD-FL-086(B) limits SO2 emissions to 29 ppmvd or 5% of the potential sulfur dioxide emission (95% reduction by weight or volume), corrected to 7% O2, whichever is less stringent.	

**Allowable Emissions** Allowable Emissions 6 of 11

1. Basis for Allowable Emissions Code: RULE	2. Future Effective Date of Allowable Emissions:
3. Allowable Emissions and Units: 1.5 lb/hour	4. Equivalent Allowable Emissions: lb/hour          6.57 tons/year
5. Method of Compliance: Compliance with H107 (Fluoride as HF) emission limits will be demonstrated every 5 years using EPA Reference Method 13A or 13B.	
6. Allowable Emissions Comment (Description of Operating Method): Limited by Florida permit PSD-FL-086(B), which also contains additional emission limit of 0.0125 lb/MMBtu.	

**F2. EMISSIONS UNIT POLLUTANT DETAIL INFORMATION -  
ALLOWABLE EMISSIONS**

**Complete Subsection F2 if the pollutant identified in Subsection F1 is or would be subject to a numerical emissions limitation.**

**Allowable Emissions** Allowable Emissions 7 of 11

1. Basis for Allowable Emissions Code: RULE	2. Future Effective Date of Allowable Emissions:
3. Allowable Emissions and Units: 0.40 mg/dscm, corrected to 7% O2	4. Equivalent Allowable Emissions: 0.0451 lb/hour 0.197 tons/year
5. Method of Compliance: Compliance with PB emission limits will be demonstrated annually using EPA Reference Method 29.	
6. Allowable Emissions Comment (Description of Operating Method): Limited by Florida permit PSD-FL-086(B), which also contains additional emission limit of 3.76E-04 lb/MMBtu. The revised 40 CFR 60 Subpart Cb limit for lead is 0.40 mg/dscm.	

**Allowable Emissions** Allowable Emissions 8 of 11

1. Basis for Allowable Emissions Code: RULE	2. Future Effective Date of Allowable Emissions:
3. Allowable Emissions and Units: 0.000115lb/hr	4. Equivalent Allowable Emissions: lb/hour 5.04E-04 tons/year
5. Method of Compliance: Compliance with H021 (Beryllium Compounds) emission limits will be demonstrated every 5 years using EPA Reference Method 29.	
6. Allowable Emissions Comment (Description of Operating Method): Limited by Florida permit PSD-FL-086(B), which also contains additional emission limit of 9.58E-07 lb/MMBtu.	

**Allowable Emissions** Allowable Emissions 9 of 11

1. Basis for Allowable Emissions Code: RULE	2. Future Effective Date of Allowable Emissions:
3. Allowable Emissions and Units: 0.050 mg/dscm or 85% removal, @ 7% O2	4. Equivalent Allowable Emissions: lb/hour 0.0605 tons/year
5. Method of Compliance: Compliance with H114 (Mercury Compounds) emission limits will be demonstrated annually using EPA Reference Method 29.	
6. Allowable Emissions Comment (Description of Operating Method): Florida permit PSD-FL-086(B) limits H114 emissions to 0.070 mg/dscm or 15% of the potential mercury emission concentration (85% reduction by weigh or volume), corrected to 7% O2, whichever is less stringent. The revised 40 CFR 60 Subpart Cb limit for mercury is 0.050 mg/dscm.	

**F2. EMISSIONS UNIT POLLUTANT DETAIL INFORMATION -  
ALLOWABLE EMISSIONS**

**Complete Subsection F2 if the pollutant identified in Subsection F1 is or would be subject to a numerical emissions limitation.**

**Allowable Emissions** Allowable Emissions 10 of 11

1. Basis for Allowable Emissions Code: RULE	2. Future Effective Date of Allowable Emissions:
3. Allowable Emissions and Units: 30 ng/dscm (total mass), corrected to 7% O2	4. Equivalent Allowable Emissions: 3.07E-06 lb/hour 1.35E-05 tons/year
5. Method of Compliance: Compliance with DOIX emission limits will be demonstrated annually using EPA Reference Method 23.	
6. Allowable Emissions Comment (Description of Operating Method): Limited by Florida permit PSD-FL-086(B), which also contains additional emission limit of 2.56E-08 lb/MMBtu.	

**Allowable Emissions** Allowable Emissions 11 of 11

1. Basis for Allowable Emissions Code: RULE	2. Future Effective Date of Allowable Emissions:
3. Allowable Emissions and Units: 0.035 mg/dscm, corrected to 7% O2	4. Equivalent Allowable Emissions: 4.10E-03 lb/hour 0.0179 tons/year 3.42E-05 lb/MMBtu
5. Method of Compliance: Compliance with H 027 (Cadmium Compounds) emission limits will be demonstrated annually using EPA Reference Method 29.	
6. Allowable Emissions Comment (Description of Operating Method): Florida permit PSD-FL-086(B). The revised 40 CFR 60 Subpart Cb limit for cadmium is 0.035 mg/dscm.	



**EMISSIONS UNIT INFORMATION**

Section [4] of [8]

**G. VISIBLE EMISSIONS INFORMATION**

**Complete Subsection G if this emissions unit is or would be subject to a unit-specific visible emissions limitation.**

**Visible Emissions Limitation:** Visible Emissions Limitation 1 of 1

1. Visible Emissions Subtype: VE10	2. Basis for Allowable Opacity: <input checked="" type="checkbox"/> Rule <input type="checkbox"/> Other
3. Allowable Opacity: Normal Conditions: 10 %      Exceptional Conditions: 100 % Maximum Period of Excess Opacity Allowed: 3 hours	
4. Method of Compliance: EPA Reference Method 9 shall be used to demonstrate compliance with the opacity limit except as provided under 40 CFR 60.11(e).	
5. Visible Emissions Comment: Excess emissions are allowed during startup, shutdown, or malfunction, provided that the duration of these events does not exceed 3 hours (40 CFR 60.56(b)).	

**Visible Emissions Limitation:** Visible Emissions Limitation    of   

1. Visible Emissions Subtype:	2. Basis for Allowable Opacity: <input type="checkbox"/> Rule <input type="checkbox"/> Other
3. Allowable Opacity: Normal Conditions: %      Exceptional Conditions: % Maximum Period of Excess Opacity Allowed: min/hour	
4. Method of Compliance:	
5. Visible Emissions Comment:	

**EMISSIONS UNIT INFORMATION**

Section [4] of [8]

**H. CONTINUOUS MONITOR INFORMATION****Complete Subsection H if this emissions unit is or would be subject to continuous monitoring.****Continuous Monitoring System:** Continuous Monitor 1 of 3

1. Parameter Code: VE	2. Pollutant(s): Visible Emissions (Opacity)
3. CMS Requirement:	<input type="checkbox"/> Rule <input type="checkbox"/> Other
4. Monitor Information... Manufacturer: Land Model Number: 4500 MK II +	
Serial Number: 0095466	
5. Installation Date:	6. Performance Specification Test Date:
7. Continuous Monitor Comment:  Monitor located at Fabric Filter outlet	

**Continuous Monitoring System:** Continuous Monitor 2 of 3

1. Parameter Code: EM, TEMP, FLOW	2. Pollutant(s): SO2, O2, Temperature, Steam Flow
3. CMS Requirement:	<input checked="" type="checkbox"/> Rule <input type="checkbox"/> Other
4. Monitor Information... Manufacturer: Sick Model Number: MCS100EHW	
Serial Number: 193	
5. Installation Date:	6. Performance Specification Test Date:
7. Continuous Monitor Comment:  Monitor located at SDA inlet	

**EMISSIONS UNIT INFORMATION**

Section [4] of [8]

**H. CONTINUOUS MONITOR INFORMATION (CONTINUED)**

**Continuous Monitoring System:** Continuous Monitor 3 of 3

1. Parameter Code: EM, TMP, FLOW	2. Pollutant(s): O2, NOx, CO, SO2, Temperature, Steam Flow
3. CMS Requirement: <input checked="" type="checkbox"/> Rule <input type="checkbox"/> Other	
4. Monitor Information... Manufacturer: Sick Model Number: MCS100EHW Serial Number: 197	
5. Installation Date:	6. Performance Specification Test Date:
7. Continuous Monitor Comment:  Monitor located at Fabric Filter outlet	

**Continuous Monitoring System:** Continuous Monitor \_\_\_ of \_\_\_

1. Parameter Code:	2. Pollutant(s):
3. CMS Requirement: <input type="checkbox"/> Rule <input type="checkbox"/> Other	
4. Monitor Information... Manufacturer: Model Number: Serial Number:	
5. Installation Date:	6. Performance Specification Test Date:
7. Continuous Monitor Comment:	

**EMISSIONS UNIT INFORMATION**

Section [4] of [8]

**I. EMISSIONS UNIT ADDITIONAL INFORMATION**

**Additional Requirements for All Applications, Except as Otherwise Stated**

1. Process Flow Diagram: (Required for all permit applications, except Title V air operation permit revision applications if this information was submitted to the department within the previous five years and would not be altered as a result of the revision being sought) <input checked="" type="checkbox"/> Attached, Document ID: <u>Appendix B</u> <input type="checkbox"/> Previously Submitted, Date _____
2. Fuel Analysis or Specification: (Required for all permit applications, except Title V air operation permit revision applications if this information was submitted to the department within the previous five years and would not be altered as a result of the revision being sought) <input checked="" type="checkbox"/> Attached, Document ID: <u>See Section 5</u> <input type="checkbox"/> Previously Submitted, Date _____
3. Detailed Description of Control Equipment: (Required for all permit applications, except Title V air operation permit revision applications if this information was submitted to the department within the previous five years and would not be altered as a result of the revision being sought) <input type="checkbox"/> Attached, Document ID: _____ <input checked="" type="checkbox"/> Previously Submitted, Date <u>December 2005</u>
4. Procedures for Startup and Shutdown: (Required for all operation permit applications, except Title V air operation permit revision applications if this information was submitted to the department within the previous five years and would not be altered as a result of the revision being sought) <input checked="" type="checkbox"/> Attached, Document ID: <u>Appendix C</u> <input type="checkbox"/> Previously Submitted, Date _____ <input type="checkbox"/> Not Applicable (construction application)
5. Operation and Maintenance Plan: (Required for all permit applications, except Title V air operation permit revision applications if this information was submitted to the department within the previous five years and would not be altered as a result of the revision being sought) <input checked="" type="checkbox"/> Attached, Document ID: <u>Appendix C</u> <input type="checkbox"/> Previously Submitted, Date _____ <input type="checkbox"/> Not Applicable
6. Compliance Demonstration Reports/Records: <input type="checkbox"/> Attached, Document ID: _____ Test Date(s)/Pollutant(s) Tested: _____ <input checked="" type="checkbox"/> Previously Submitted, Date: _____ Test Date(s)/Pollutant(s) Tested: <u>FY 2010 compliance testing results and 2009 Statement of Compliance are included in Appendix D.</u> <input type="checkbox"/> To be Submitted, Date (if known): _____ Test Date(s)/Pollutant(s) Tested: _____ <input type="checkbox"/> Not Applicable Note: For FESOP applications, all required compliance demonstration records/reports must be submitted at the time of application. For Title V air operation permit applications, all required compliance demonstration reports/records must be submitted at the time of application, or a compliance plan must be submitted at the time of application.
7. Other Information Required by Rule or Statute: <input type="checkbox"/> Attached, Document ID: _____ <input checked="" type="checkbox"/> Not Applicable

**EMISSIONS UNIT INFORMATION**

Section [4] of [8]

**I. EMISSIONS UNIT ADDITIONAL INFORMATION (CONTINUED)**

**Additional Requirements for Air Construction Permit Applications**

1. Control Technology Review and Analysis (Rules 62-212.400(10) and 62-212.500(7), F.A.C.; 40 CFR 63.43(d) and (e)): <input type="checkbox"/> Attached, Document ID: _____ <input checked="" type="checkbox"/> Not Applicable
2. Good Engineering Practice Stack Height Analysis (Rules 62-212.400(4)(d) and 62-212.500(4)(f), F.A.C.): <input type="checkbox"/> Attached, Document ID: _____ <input checked="" type="checkbox"/> Not Applicable
3. Description of Stack Sampling Facilities: (Required for proposed new stack sampling facilities only) <input type="checkbox"/> Attached, Document ID: _____ <input checked="" type="checkbox"/> Not Applicable

**Additional Requirements for Title V Air Operation Permit Applications**

1. Identification of Applicable Requirements: <input checked="" type="checkbox"/> Attached, Document ID: <u>See Section 4</u>
2. Compliance Assurance Monitoring: <input type="checkbox"/> Attached, Document ID: _____ <input checked="" type="checkbox"/> Not Applicable <u>See Section 4</u>
3. Alternative Methods of Operation: <input type="checkbox"/> Attached, Document ID: _____ <input checked="" type="checkbox"/> Not Applicable
4. Alternative Modes of Operation (Emissions Trading): <input type="checkbox"/> Attached, Document ID: _____ <input checked="" type="checkbox"/> Not Applicable

**Additional Requirements Comment**

None
------

**EMISSIONS UNIT INFORMATION**

Section [5] of [8]

**A. GENERAL EMISSIONS UNIT INFORMATION**

**Title V Air Operation Permit Emissions Unit Classification**

1. Regulated or Unregulated Emissions Unit? (Check one, if applying for an initial, revised or renewal Title V air operation permit. Skip this item if applying for an air construction permit or FESOP only.)

- The emissions unit addressed in this Emissions Unit Information Section is a regulated emissions unit.
- The emissions unit addressed in this Emissions Unit Information Section is an unregulated emissions unit.

**Emissions Unit Description and Status**

1. Type of Emissions Unit Addressed in this Section: (Check one)

- This Emissions Unit Information Section addresses, as a single emissions unit, a single process or production unit, or activity, which produces one or more air pollutants and which has at least one definable emission point (stack or vent).
- This Emissions Unit Information Section addresses, as a single emissions unit, a group of process or production units and activities which has at least one definable emission point (stack or vent) but may also produce fugitive emissions.
- This Emissions Unit Information Section addresses, as a single emissions unit, one or more process or production units and activities which produce fugitive emissions only.

2. Description of Emissions Unit Addressed in this Section:

Municipal Waste Combustors and Auxiliary Burners – Unit No. 2

3. Emissions Unit Identification Number: 104

4. Emissions Unit Status Code: A	5. Commence Construction Date:	6. Initial Startup Date: 08/30/2001	7. Emissions Unit Major Group SIC Code: 49
-------------------------------------	--------------------------------	--	--

8. Federal Program Applicability: (Check all that apply)

- Acid Rain Unit **Not Applicable**
- CAIR Unit

9. Package Unit:

Manufacturer: D.B. Riley

Model Number: 2754

10. Generator Nameplate Rating: 22.5 MW

11. Emissions Unit Comment:

Excess emissions are allowed during startup, shutdown, or malfunction, provided that the duration of these events does not exceed 3 hours per occurrence. For CO compliance, the duration of a malfunction period is limited to 15 hours per occurrence.

**EMISSIONS UNIT INFORMATION**

Section [5] of [8]

**Emissions Unit Control Equipment/Method:** Control 1 of 1

- |  |
|--|
| 1. Control Equipment/Method Description:<br>This emissions unit equipped with a spray dryer absorber (SDA), activated carbon injection system, fabric filter baghouse, and selective non-catalytic reduction (SNCR). |
| 2. Control Device or Method Code: 016, 048, 067, 107   |

**Emissions Unit Control Equipment/Method:** Control \_\_\_ of \_\_\_

- |  |
|--|
| 1. Control Equipment/Method Description: |
| 2. Control Device or Method Code:        |

**Emissions Unit Control Equipment/Method:** Control \_\_\_ of \_\_\_

- |  |
|--|
| 1. Control Equipment/Method Description: |
| 2. Control Device or Method Code:        |

**Emissions Unit Control Equipment/Method:** Control \_\_\_ of \_\_\_

- |  |
|--|
| 1. Control Equipment/Method Description: |
| 2. Control Device or Method Code:        |

**EMISSIONS UNIT INFORMATION**

Section [5] of [8]

**B. EMISSIONS UNIT CAPACITY INFORMATION**

(Optional for unregulated emissions units.)

**Emissions Unit Operating Capacity and Schedule**

1. Maximum Process or Throughput Rate:
2. Maximum Production Rate:
3. Maximum Heat Input Rate: million 120 MMBtu/hr (see item 6)
4. Maximum Incineration Rate: pounds/hr 288 tons/day
5. Requested Maximum Operating Schedule: 24 hours/day 7 days/week 52 weeks/year 8,760 hours/year
6. Operating Capacity/Schedule Comment:  120 MMBtu/hour heat input rate for information purposes only, not for compliance. Maximum steam flow and nominal capacity are limited by Limited by Florida permit PSD-FL-086(B).



**EMISSIONS UNIT INFORMATION**

Section [5] of [8]

**C. EMISSION POINT (STACK/VENT) INFORMATION****(Optional for unregulated emissions units.)****Emission Point Description and Type**

1. Identification of Point on Plot Plan or Flow Diagram: See Appendix A		2. Emission Point Type Code: 1	
3. Descriptions of Emission Points Comprising this Emissions Unit for VE Tracking:  <b>Not Applicable</b>			
4. ID Numbers or Descriptions of Emission Units with this Emission Point in Common:  <b>Not Applicable</b>			
5. Discharge Type Code: V	6. Stack Height: 201 feet	7. Exit Diameter: 4.2 feet	
8. Exit Temperature: 315 °F	9. Actual Volumetric Flow Rate: 60,894 acfm	10. Water Vapor: 20 % ±	
11. Maximum Dry Standard Flow Rate: 36,686 dscfm		12. Nonstack Emission Point Height: Feet	
13. Emission Point UTM Coordinates... Zone: 17    East (km): 360.0 North (km): 3091.9		14. Emission Point Latitude/Longitude... Latitude (DD/MM/SS) Longitude (DD/MM/SS)	
15. Emission Point Comment:  Four MWCs have separate stacks (flues) located within a common enclosure.			

**EMISSIONS UNIT INFORMATION**

Section [5] of [8]

**D. SEGMENT (PROCESS/FUEL) INFORMATION****Segment Description and Rate:** Segment 1 of 2

1. Segment Description (Process/Fuel Type):  Solid Waste Disposal – Government Municipal Incineration – Stationary Mass Burn Waterwall Combustor		
2. Source Classification Code (SCC): 50100105		3. SCC Units: Tons burned (all solid fuels)
4. Maximum Hourly Rate: See item 10	5. Maximum Annual Rate: See item 10	6. Estimated Annual Activity Factor:
7. Maximum % Sulfur: N/A	8. Maximum % Ash: N/A	9. Million Btu per SCC Unit: <b>10 ±</b>
10. Segment Comment:  PSD-FL-086(B) limits nominal heat input to 104 MMBtu/hr and nominal capacity to 250 tons per day (rolling 12-month average).		

**Segment Description and Rate:** Segment 2 of 2

1. Segment Description (Process/Fuel Type):  Solid Waste Disposal – Government Auxiliary Fuel/No Emissions – Natural Gas		
2. Source Classification Code (SCC): 50100106		3. SCC Units: Million Cubic Feet Burned (all gaseous fuels)
4. Maximum Hourly Rate: See item 10	5. Maximum Annual Rate: See item 10	6. Estimated Annual Activity Factor:
7. Maximum % Sulfur:	8. Maximum % Ash:	9. Million Btu per SCC Unit: 1027 ±
10. Segment Comment:  PSD-FL-086(B) limits the maximum hourly rate by the 10% annual capacity factor.		

**EMISSIONS UNIT INFORMATION**

Section [5] of [8]

**E. EMISSIONS UNIT POLLUTANTS****List of Pollutants Emitted by Emissions Unit**

1. Pollutant Emitted	2. Primary Control Device Code	3. Secondary Control Device Code	4. Pollutant Regulatory Code
PM	016		EL
SO2	067	016	EL
NOx	107		EL
CO			EL
HCL (H106)	067	016	EL
H107	016		EL
PB	016		EL
H021	016		EL
H114	048		EL
DIOX	067	016	EL
H027	016		EL

**F1. EMISSIONS UNIT POLLUTANT DETAIL INFORMATION –  
POTENTIAL, FUGITIVE, AND ACTUAL EMISSIONS**

(Optional for unregulated emissions units.)

Complete a Subsection F1 for each pollutant identified in Subsection E if applying for an air construction permit or concurrent processing of an air construction permit and a revised or renewal Title V operation permit. Complete for each emissions-limited pollutant identified in Subsection E if applying for an air operation permit.

**Potential, Estimated Fugitive, and Baseline & Projected Actual Emissions**

1. Pollutant Emitted: PM		2. Total Percent Efficiency of Control:	
3. Potential Emissions: 2.76 lb/hour                      12.1 tons/year		4. Synthetically Limited? <input type="checkbox"/> Yes <input checked="" type="checkbox"/> No	
5. Range of Estimated Fugitive Emissions (as applicable): to tons/year			
6. Emission Factor: 25 mg/dscm, corrected to 7% O2 Reference: Revised 40 CFR 60 Subpart Cb		7. Emissions Method Code: 0	
8.a. Baseline Actual Emissions (if required): tons/year		8.b. Baseline 24-month Period: From:                      To:	
9.a. Projected Actual Emissions (if required): tons/year		9.b. Projected Monitoring Period: <input type="checkbox"/> 5 years <input type="checkbox"/> 10 years	
10. Calculation of Emissions:  Limited by Florida permit PSD-FL-086(B) and revised 40 CFR 60 Subpart Cb			
11. Potential, Fugitive, and Actual Emissions Comment:  Limited by Florida permit PSD-FL-086(B). The current permitted emissions limit for PM is 27 mg/dscm and the revised 40 CFR 60 Subpart Cb limit is 25 mg/dscm.			

**F1. EMISSIONS UNIT POLLUTANT DETAIL INFORMATION –  
 POTENTIAL, FUGITIVE, AND ACTUAL EMISSIONS**  
 (Optional for unregulated emissions units.)

Complete a Subsection F1 for each pollutant identified in Subsection E if applying for an air construction permit or concurrent processing of an air construction permit and a revised or renewal Title V operation permit. Complete for each emissions-limited pollutant identified in Subsection E if applying for an air operation permit.

**Potential, Estimated Fugitive, and Baseline & Projected Actual Emissions**

1. Pollutant Emitted: SO2		2. Total Percent Efficiency of Control:	
3. Potential Emissions: lb/hour		4. Synthetically Limited? <input type="checkbox"/> Yes <input checked="" type="checkbox"/> No	
5. Range of Estimated Fugitive Emissions (as applicable): to tons/year			
6. Emission Factor: 29 ppmvd or 75% removal, corrected to 7% O2 Reference: PSD-FL-086(B)		7. Emissions Method Code: 0	
8.a. Baseline Actual Emissions (if required): tons/year		8.b. Baseline 24-month Period: From: To:	
9.a. Projected Actual Emissions (if required): tons/year		9.b. Projected Monitoring Period: <input type="checkbox"/> 5 years <input type="checkbox"/> 10 years	
10. Calculation of Emissions:  Limited by Florida permit PSD-FL-086(B)			
11. Potential, Fugitive, and Actual Emissions Comment:  Florida permit PSD-FL-086(B) limits SO2 emissions to 29 ppmvd or 25% of the potential sulfur dioxide emission (75% reduction by weight or volume), corrected to 7% O2, whichever is less stringent. Facility-wide SO2 emissions limited to 460 tons/year.			

**F1. EMISSIONS UNIT POLLUTANT DETAIL INFORMATION –  
POTENTIAL, FUGITIVE, AND ACTUAL EMISSIONS**

**(Optional for unregulated emissions units.)**

**Complete a Subsection F1 for each pollutant identified in Subsection E if applying for an air construction permit or concurrent processing of an air construction permit and a revised or renewal Title V operation permit. Complete for each emissions-limited pollutant identified in Subsection E if applying for an air operation permit.**

**Potential, Estimated Fugitive, and Baseline & Projected Actual Emissions**

1. Pollutant Emitted: NOx		2. Total Percent Efficiency of Control:	
3. Potential Emissions: 40.1 lb/hour                                  tons/year		4. Synthetically Limited? <input type="checkbox"/> Yes <input checked="" type="checkbox"/> No	
5. Range of Estimated Fugitive Emissions (as applicable): to tons/year			
6. Emission Factor: 205 ppmvd, corrected to 7% O2 Reference: PSD-FL-086(B)		7. Emissions Method Code: 0	
8.a. Baseline Actual Emissions (if required): tons/year		8.b. Baseline 24-month Period: From:                                  To:	
9.a. Projected Actual Emissions (if required): tons/year		9.b. Projected Monitoring Period: <input type="checkbox"/> 5 years <input type="checkbox"/> 10 years	
10. Calculation of Emissions:  Limited by Florida permit PSD-FL-086(B)			
11. Potential, Fugitive, and Actual Emissions Comment:  Limited by Florida permit PSD-FL-086(B), which also contains additional emission limit of 0.335 lb/MMBtu. Facility-wide NOx emission limited to 679 tons/year.			

**F1. EMISSIONS UNIT POLLUTANT DETAIL INFORMATION –  
POTENTIAL, FUGITIVE, AND ACTUAL EMISSIONS**  
(Optional for unregulated emissions units.)

Complete a Subsection F1 for each pollutant identified in Subsection E if applying for an air construction permit or concurrent processing of an air construction permit and a revised or renewal Title V operation permit. Complete for each emissions-limited pollutant identified in Subsection E if applying for an air operation permit.

**Potential, Estimated Fugitive, and Baseline & Projected Actual Emissions**

1. Pollutant Emitted: CO		2. Total Percent Efficiency of Control:	
3. Potential Emissions: 11.91 lb/hour                      tons/year		4. Synthetically Limited? <input type="checkbox"/> Yes <input checked="" type="checkbox"/> No	
5. Range of Estimated Fugitive Emissions (as applicable): to tons/year			
6. Emission Factor: 100 ppmvd, corrected to 7% O2 Reference: PSD-FL-086(B)		7. Emissions Method Code: 0	
8.a. Baseline Actual Emissions (if required): tons/year		8.b. Baseline 24-month Period: From:                      To:	
9.a. Projected Actual Emissions (if required): tons/year		9.b. Projected Monitoring Period: <input type="checkbox"/> 5 years <input type="checkbox"/> 10 years	
10. Calculation of Emissions:  Limited by Florida permit PSD-FL-086(B)			
11. Potential, Fugitive, and Actual Emissions Comment:  Limited by Florida permit PSD-FL-086(B), which also contains additional emission limit of 0.0995 lb/MMBtu. Facility-wide CO emission limited to 185 tons/year.			

**F1. EMISSIONS UNIT POLLUTANT DETAIL INFORMATION –  
POTENTIAL, FUGITIVE, AND ACTUAL EMISSIONS**  
(Optional for unregulated emissions units.)

Complete a Subsection F1 for each pollutant identified in Subsection E if applying for an air construction permit or concurrent processing of an air construction permit and a revised or renewal Title V operation permit. Complete for each emissions-limited pollutant identified in Subsection E if applying for an air operation permit.

**Potential, Estimated Fugitive, and Baseline & Projected Actual Emissions**

1. Pollutant Emitted: HCL (H106)		2. Total Percent Efficiency of Control:	
3. Potential Emissions: lb/hour 67.9 tons/year		4. Synthetically Limited? <input type="checkbox"/> Yes <input checked="" type="checkbox"/> No	
5. Range of Estimated Fugitive Emissions (as applicable): to tons/year			
6. Emission Factor: 29 ppmvd or 95% removal, corrected to 7% O2 Reference: PSD-FL-086(B)		7. Emissions Method Code: 0	
8.a. Baseline Actual Emissions (if required): tons/year		8.b. Baseline 24-month Period: From: To:	
9.a. Projected Actual Emissions (if required): tons/year		9.b. Projected Monitoring Period: <input type="checkbox"/> 5 years <input type="checkbox"/> 10 years	
10. Calculation of Emissions:  Limited by Florida permit PSD-FL-086(B)			
11. Potential, Fugitive, and Actual Emissions Comment:  Limited by Florida permit PSD-FL-086(B) limits HCL emissions to 29 ppmvd or 5% of the potential sulfur dioxide emission (95% reduction by weight or volume), corrected to 7% O2, whichever is less stringent.			



**F1. EMISSIONS UNIT POLLUTANT DETAIL INFORMATION –  
POTENTIAL, FUGITIVE, AND ACTUAL EMISSIONS**  
(Optional for unregulated emissions units.)

Complete a Subsection F1 for each pollutant identified in Subsection E if applying for an air construction permit or concurrent processing of an air construction permit and a revised or renewal Title V operation permit. Complete for each emissions-limited pollutant identified in Subsection E if applying for an air operation permit.

**Potential, Estimated Fugitive, and Baseline & Projected Actual Emissions**

1. Pollutant Emitted: H107 (Fluoride as HF)		2. Total Percent Efficiency of Control:	
3. Potential Emissions: 1.5 lb/hour                      6.57 tons/year		4. Synthetically Limited? <input type="checkbox"/> Yes <input checked="" type="checkbox"/> No	
5. Range of Estimated Fugitive Emissions (as applicable): to tons/year			
6. Emission Factor: Reference: PSD-FL-086(B)		7. Emissions Method Code: 0	
8.a. Baseline Actual Emissions (if required): tons/year		8.b. Baseline 24-month Period: From:                      To:	
9.a. Projected Actual Emissions (if required): tons/year		9.b. Projected Monitoring Period: <input type="checkbox"/> 5 years <input type="checkbox"/> 10 years	
10. Calculation of Emissions:  Limited by Florida permit PSD-FL-086(B)			
11. Potential, Fugitive, and Actual Emissions Comment:  Limited by Florida permit PSD-FL-086(B), which also contains additional emission limit of 0.0125 lb/MMBtu.			

**F1. EMISSIONS UNIT POLLUTANT DETAIL INFORMATION –  
POTENTIAL, FUGITIVE, AND ACTUAL EMISSIONS  
(Optional for unregulated emissions units.)**

Complete a Subsection F1 for each pollutant identified in Subsection E if applying for an air construction permit or concurrent processing of an air construction permit and a revised or renewal Title V operation permit. Complete for each emissions-limited pollutant identified in Subsection E if applying for an air operation permit.

**Potential, Estimated Fugitive, and Baseline & Projected Actual Emissions**

1. Pollutant Emitted: PB		2. Total Percent Efficiency of Control:	
3. Potential Emissions: 0.0451 lb/hour      0.197 tons/year		4. Synthetically Limited? <input type="checkbox"/> Yes <input checked="" type="checkbox"/> No	
5. Range of Estimated Fugitive Emissions (as applicable): to tons/year			
6. Emission Factor: 0.40 mg/dscm, corrected to 7% O2 Reference: Revised 40 CFR 60 Subpart Cb		7. Emissions Method Code: 0	
8.a. Baseline Actual Emissions (if required): tons/year		8.b. Baseline 24-month Period: From:                          To:	
9.a. Projected Actual Emissions (if required): tons/year		9.b. Projected Monitoring Period: <input type="checkbox"/> 5 years <input type="checkbox"/> 10 years	
10. Calculation of Emissions:  Limited by Florida permit PSD-FL-086(B) and revised 40 CFR 60 Subpart Cb			
11. Potential, Fugitive, and Actual Emissions Comment:  Limited by Florida permit PSD-FL-086(B), which also contains additional emission limit of 3.76E-04 lb/MMBtu. The current permitted emissions limit for lead is 0.44 mg/dscm and the revised 40 CFR 60 Subpart Cb limit is 0.40 mg/dscm.			

**F1. EMISSIONS UNIT POLLUTANT DETAIL INFORMATION –  
POTENTIAL, FUGITIVE, AND ACTUAL EMISSIONS**  
(Optional for unregulated emissions units.)

Complete a Subsection F1 for each pollutant identified in Subsection E if applying for an air construction permit or concurrent processing of an air construction permit and a revised or renewal Title V operation permit. Complete for each emissions-limited pollutant identified in Subsection E if applying for an air operation permit.

**Potential, Estimated Fugitive, and Baseline & Projected Actual Emissions**

1. Pollutant Emitted: H021 (Beryllium Compounds)		2. Total Percent Efficiency of Control:	
3. Potential Emissions: 0.000115 lb/hour 5.04E-04 tons/year		4. Synthetically Limited? <input type="checkbox"/> Yes <input checked="" type="checkbox"/> No	
5. Range of Estimated Fugitive Emissions (as applicable): to tons/year			
6. Emission Factor: Reference: PSD-FL-086(B)		7. Emissions Method Code: 0	
8.a. Baseline Actual Emissions (if required): tons/year		8.b. Baseline 24-month Period: From: To:	
9.a. Projected Actual Emissions (if required): tons/year		9.b. Projected Monitoring Period: <input type="checkbox"/> 5 years <input type="checkbox"/> 10 years	
10. Calculation of Emissions:  Limited by Florida permit PSD-FL-086(B)			
11. Potential, Fugitive, and Actual Emissions Comment:  Limited by Florida permit PSD-FL-086(B), which also contains additional emission limit of 9.58E-07 lb/MMBtu.			

**F1. EMISSIONS UNIT POLLUTANT DETAIL INFORMATION –  
 POTENTIAL, FUGITIVE, AND ACTUAL EMISSIONS**  
 (Optional for unregulated emissions units.)

**Complete a Subsection F1 for each pollutant identified in Subsection E if applying for an air construction permit or concurrent processing of an air construction permit and a revised or renewal Title V operation permit. Complete for each emissions-limited pollutant identified in Subsection E if applying for an air operation permit.**

**Potential, Estimated Fugitive, and Baseline & Projected Actual Emissions**

1. Pollutant Emitted: H114 (Mercury Compounds)		2. Total Percent Efficiency of Control:	
3. Potential Emissions: lb/hour                      0.0605 tons/year		4. Synthetically Limited? <input type="checkbox"/> Yes <input checked="" type="checkbox"/> No	
5. Range of Estimated Fugitive Emissions (as applicable): to tons/year			
6. Emission Factor: 0.050 mg/dscm or 85% reduction, corrected to 7% O <sub>2</sub>  Reference: Revised 40 CFR 60 Subpart Cb		7. Emissions Method Code: 0	
8.a. Baseline Actual Emissions (if required): tons/year		8.b. Baseline 24-month Period: From:                      To:	
9.a. Projected Actual Emissions (if required): tons/year		9.b. Projected Monitoring Period: <input type="checkbox"/> 5 years <input type="checkbox"/> 10 years	
10. Calculation of Emissions:  Limited by Florida permit PSD-FL-086(B) and revised 40 CFR 60 Subpart Cb			
11. Potential, Fugitive, and Actual Emissions Comment:  Limited by Florida permit PSD-FL-086(B) limits H114 emissions to 0.070 mg/dscm or 15% of the potential mercury emission concentration (85% reduction by weight or volume), corrected to 7% O <sub>2</sub> , whichever is less stringent. The current permitted emissions limit for mercury is 0.070 mg/dscm and the revised 40 CFR 60 Subpart Cb limit is 0.050 mg/dscm.			

**F1. EMISSIONS UNIT POLLUTANT DETAIL INFORMATION –  
POTENTIAL, FUGITIVE, AND ACTUAL EMISSIONS**  
(Optional for unregulated emissions units.)

Complete a Subsection F1 for each pollutant identified in Subsection E if applying for an air construction permit or concurrent processing of an air construction permit and a revised or renewal Title V operation permit. Complete for each emissions-limited pollutant identified in Subsection E if applying for an air operation permit.

**Potential, Estimated Fugitive, and Baseline & Projected Actual Emissions**

1. Pollutant Emitted: DIOX		2. Total Percent Efficiency of Control:	
3. Potential Emissions: 3.07E-06 lb/hour 1.35E-05 tons/year		4. Synthetically Limited? <input type="checkbox"/> Yes <input checked="" type="checkbox"/> No	
5. Range of Estimated Fugitive Emissions (as applicable): to tons/year			
6. Emission Factor: 30 ng/dscm (total mass), corrected to 7% O2 Reference: PSD-FL-086(B)		7. Emissions Method Code: 0	
8.a. Baseline Actual Emissions (if required): tons/year		8.b. Baseline 24-month Period: From: To:	
9.a. Projected Actual Emissions (if required): tons/year		9.b. Projected Monitoring Period: <input type="checkbox"/> 5 years <input type="checkbox"/> 10 years	
10. Calculation of Emissions:  Limited by Florida permit PSD-FL-086(B)			
11. Potential, Fugitive, and Actual Emissions Comment:  Limited by Florida permit PSD-FL-086(B), which also contains additional emission limit of 2.56E-08 lb/MMBtu.			

**F1. EMISSIONS UNIT POLLUTANT DETAIL INFORMATION –  
 POTENTIAL, FUGITIVE, AND ACTUAL EMISSIONS**  
 (Optional for unregulated emissions units.)

Complete a Subsection F1 for each pollutant identified in Subsection E if applying for an air construction permit or concurrent processing of an air construction permit and a revised or renewal Title V operation permit. Complete for each emissions-limited pollutant identified in Subsection E if applying for an air operation permit.

**Potential, Estimated Fugitive, and Baseline & Projected Actual Emissions**

1. Pollutant Emitted: H027 (Cadmium Compounds)		2. Total Percent Efficiency of Control:	
3. Potential Emissions: 4.10E-03 lb/hour    0.0179 tons/year		4. Synthetically Limited? <input type="checkbox"/> Yes <input checked="" type="checkbox"/> No	
5. Range of Estimated Fugitive Emissions (as applicable): to tons/year			
6. Emission Factor: 0.035 mg/dscm, corrected to 7% O2 Reference: Revised 40 CFR 60 Subpart Cb		7. Emissions Method Code: 0	
8.a. Baseline Actual Emissions (if required): tons/year		8.b. Baseline 24-month Period: From:                      To:	
9.a. Projected Actual Emissions (if required): tons/year		9.b. Projected Monitoring Period: <input type="checkbox"/> 5 years <input type="checkbox"/> 10 years	
10. Calculation of Emissions:  Limited by Florida permit PSD-FL-086(B) and revised 40 CFR 60 Subpart Cb			
11. Potential, Fugitive, and Actual Emissions Comment:  Limited by Florida permit PSD-FL-086(B), which also contains additional emission limit of 3.24E-05 lb/MMBtu. The current permitted emissions limit for cadmium is 0.040 mg/dscm and the revised 40 CFR 60 Subpart Cb limit is 0.035 mg/dscm.			

**F2. EMISSIONS UNIT POLLUTANT DETAIL INFORMATION -  
ALLOWABLE EMISSIONS**

**Complete Subsection F2 if the pollutant identified in Subsection F1 is or would be subject to a numerical emissions limitation.**

**Allowable Emissions** Allowable Emissions 1 of 11

1. Basis for Allowable Emissions Code: RULE	2. Future Effective Date of Allowable Emissions:
3. Allowable Emissions and Units: 25 mg/dscm, corrected to 7% O <sub>2</sub>	4. Equivalent Allowable Emissions: 2.76 lb/hour      12.1 tons/year
5. Method of Compliance: Compliance with PM emission limits will be demonstrated annually using EPA Reference Method 5.	
6. Allowable Emissions Comment (Description of Operating Method): Limited by Florida permit PSD-FL-086(B). The revised 40 CFR 60 Subpart Cb limit for PM is 25 mg/dscm.	

**Allowable Emissions** Allowable Emissions 2 of 11

1. Basis for Allowable Emissions Code: RULE	2. Future Effective Date of Allowable Emissions:
3. Allowable Emissions and Units: 29 ppmvd or 75% reduction, corrected to 7% O <sub>2</sub>	4. Equivalent Allowable Emissions: lb/hour      tons/year
5. Method of Compliance: Compliance with SO <sub>2</sub> emission limits will be demonstrated via CEMS using EPA Reference Method 19 to calculate the daily geometric average SO <sub>2</sub> concentration.	
6. Allowable Emissions Comment (Description of Operating Method): Florida permit PSD-FL-086(B) limits SO <sub>2</sub> emissions to 29 ppmvd or 25% of the potential sulfur dioxide emission (75% reduction by weight or volume), corrected to 7% O <sub>2</sub> , whichever is less stringent. Facility-wide SO <sub>2</sub> emission limited to 460 tons/year.	

**Allowable Emissions** Allowable Emissions 3 of 11

1. Basis for Allowable Emissions Code: RULE	2. Future Effective Date of Allowable Emissions:
3. Allowable Emissions and Units: 205 ppmvd, corrected to 7% O <sub>2</sub>	4. Equivalent Allowable Emissions: 40.1 lb/hour      tons/year
5. Method of Compliance: Compliance with NO <sub>x</sub> emission limits will be demonstrated via CEMS using EPA Reference Method 19 to calculate the daily arithmetic average NO <sub>x</sub> concentration.	
6. Allowable Emissions Comment (Description of Operating Method): Limited by Florida permit PSD-FL-086(B). Facility-wide NO <sub>x</sub> emissions limited to 679 tons/year.	

**F2. EMISSIONS UNIT POLLUTANT DETAIL INFORMATION -  
 ALLOWABLE EMISSIONS**

**Complete Subsection F2 if the pollutant identified in Subsection F1 is or would be subject to a numerical emissions limitation.**

**Allowable Emissions** Allowable Emissions 4 of 11

1. Basis for Allowable Emissions Code: RULE	2. Future Effective Date of Allowable Emissions:
3. Allowable Emissions and Units: 100 ppmvd, corrected to 7% O2	4. Equivalent Allowable Emissions: 11.9 lb/hour          tons/year
5. Method of Compliance: Compliance with CO emission limits will be demonstrated via CEMS using a 4-hour block average.	
6. Allowable Emissions Comment (Description of Operating Method): Limited by Florida permit PSD-FL-086(B). Facility-wide CO emissions limited to 185 tons/year.	

**Allowable Emissions** Allowable Emissions 5 of 11

1. Basis for Allowable Emissions Code: RULE	2. Future Effective Date of Allowable Emissions:
3. Allowable Emissions and Units: 29 ppmvd or 95% removal, corrected to 7% O2	4. Equivalent Allowable Emissions: lb/hour          67.9 tons/year
5. Method of Compliance: Compliance with HCL emission limits will be demonstrated annually using EPA Reference Method 26 or 26A.	
6. Allowable Emissions Comment (Description of Operating Method): Florida permit PSD-FL-086(B) limits SO2 emissions to 29 ppmvd or 5% of the potential sulfur dioxide emission (95% reduction by weight or volume), corrected to 7% O2, whichever is less stringent.	

**Allowable Emissions** Allowable Emissions 6 of 11

1. Basis for Allowable Emissions Code: RULE	2. Future Effective Date of Allowable Emissions:
3. Allowable Emissions and Units: 1.5 lb/hour	4. Equivalent Allowable Emissions: lb/hour          6.57 tons/year
5. Method of Compliance: Compliance with H107 (Fluoride as HF) emission limits will be demonstrated every 5 years using EPA Reference Method 13A or 13B.	
6. Allowable Emissions Comment (Description of Operating Method): Limited by Florida permit PSD-FL-086(B), which also contains additional emission limit of 0.0125 lb/MMBtu.	



**F2. EMISSIONS UNIT POLLUTANT DETAIL INFORMATION -  
ALLOWABLE EMISSIONS**

**Complete Subsection F2 if the pollutant identified in Subsection F1 is or would be subject to a numerical emissions limitation.**

**Allowable Emissions** Allowable Emissions 7 of 11

1. Basis for Allowable Emissions Code: RULE	2. Future Effective Date of Allowable Emissions:
3. Allowable Emissions and Units: 0.40 mg/dscm, corrected to 7% O2	4. Equivalent Allowable Emissions: 0.0451 lb/hour 0.197 tons/year
5. Method of Compliance: Compliance with PB emission limits will be demonstrated annually using EPA Reference Method 29.	
6. Allowable Emissions Comment (Description of Operating Method): Limited by Florida permit PSD-FL-086(B), which also contains additional emission limit of 3.76E-04 lb/MMBtu. The revised 40 CFR 60 Subpart Cb limit for lead is 0.40 mg/dscm.	

**Allowable Emissions** Allowable Emissions 8 of 11

1. Basis for Allowable Emissions Code: RULE	2. Future Effective Date of Allowable Emissions:
3. Allowable Emissions and Units: 0.000115lb/hr	4. Equivalent Allowable Emissions: lb/hour 5.04E-04 tons/year
5. Method of Compliance: Compliance with H021 (Beryllium Compounds) emission limits will be demonstrated every 5 years using EPA Reference Method 29.	
6. Allowable Emissions Comment (Description of Operating Method): Limited by Florida permit PSD-FL-086(B), which also contains additional emission limit of 9.58E-07 lb/MMBtu.	

**Allowable Emissions** Allowable Emissions 9 of 11

1. Basis for Allowable Emissions Code: RULE	2. Future Effective Date of Allowable Emissions:
3. Allowable Emissions and Units: 0.050 mg/dscm or 85% removal, @ 7% O2	4. Equivalent Allowable Emissions: lb/hour 0.0605 tons/year
5. Method of Compliance: Compliance with H114 (Mercury Compounds) emission limits will be demonstrated annually using EPA Reference Method 29.	
6. Allowable Emissions Comment (Description of Operating Method): Florida permit PSD-FL-086(B) limits H114 emissions to 0.070 mg/dscm or 15% of the potential mercury emission concentration (85% reduction by weigh or volume), corrected to 7% O2, whichever is less stringent. The revised 40 CFR 60 Subpart Cb limit for mercury is 0.050 mg/dscm.	

**F2. EMISSIONS UNIT POLLUTANT DETAIL INFORMATION -  
 ALLOWABLE EMISSIONS**

**Complete Subsection F2 if the pollutant identified in Subsection F1 is or would be subject to a numerical emissions limitation.**

**Allowable Emissions** Allowable Emissions 10 of 11

1. Basis for Allowable Emissions Code: RULE	2. Future Effective Date of Allowable Emissions:
3. Allowable Emissions and Units: 30 ng/dscm (total mass), corrected to 7% O <sub>2</sub>	4. Equivalent Allowable Emissions: 3.07E-06 lb/hour 1.35E-05 tons/year
5. Method of Compliance: Compliance with DOIX emission limits will be demonstrated annually using EPA Reference Method 23.	
6. Allowable Emissions Comment (Description of Operating Method): Limited by Florida permit PSD-FL-086(B), which also contains additional emission limit of 2.56E-08 lb/MMBtu.	

**Allowable Emissions** Allowable Emissions 11 of 11

1. Basis for Allowable Emissions Code: RULE	2. Future Effective Date of Allowable Emissions:
3. Allowable Emissions and Units: 0.035 mg/dscm, corrected to 7% O <sub>2</sub>	4. Equivalent Allowable Emissions: 4.10E-03 lb/hour 0.0179 tons/year 3.42E-05 lb/MMBtu
5. Method of Compliance: Compliance with H 027 (Cadmium Compounds) emission limits will be demonstrated annually using EPA Reference Method 29.	
6. Allowable Emissions Comment (Description of Operating Method): Florida permit PSD-FL-086(B). The revised 40 CFR 60 Subpart Cb limit for cadmium is 0.035 mg/dscm.	

**EMISSIONS UNIT INFORMATION**

Section [5] of [8]

**G. VISIBLE EMISSIONS INFORMATION**

**Complete Subsection G if this emissions unit is or would be subject to a unit-specific visible emissions limitation.**

**Visible Emissions Limitation:** Visible Emissions Limitation 1 of 1

1. Visible Emissions Subtype: VE10	2. Basis for Allowable Opacity: <input checked="" type="checkbox"/> Rule <input type="checkbox"/> Other
3. Allowable Opacity: Normal Conditions: 10 %      Exceptional Conditions: 100 % Maximum Period of Excess Opacity Allowed: 3 hours	
4. Method of Compliance: EPA Reference Method 9 shall be used to demonstrate compliance with the opacity limit except as provided under 40 CFR 60.11(e).	
5. Visible Emissions Comment: Excess emissions are allowed during startup, shutdown, or malfunction, provided that the duration of these events does not exceed 3 hours (40 CFR 60.56(b)).	

**Visible Emissions Limitation:** Visible Emissions Limitation    of   

1. Visible Emissions Subtype:	2. Basis for Allowable Opacity: <input type="checkbox"/> Rule <input type="checkbox"/> Other
3. Allowable Opacity: Normal Conditions: %      Exceptional Conditions: % Maximum Period of Excess Opacity Allowed: min/hour	
4. Method of Compliance:	
5. Visible Emissions Comment:	

**EMISSIONS UNIT INFORMATION**

Section [5] of [8]

**H. CONTINUOUS MONITOR INFORMATION****Complete Subsection H if this emissions unit is or would be subject to continuous monitoring.****Continuous Monitoring System:** Continuous Monitor 1 of 3

1. Parameter Code: VE	2. Pollutant(s): Visible Emissions (Opacity)
3. CMS Requirement:	<input type="checkbox"/> Rule <input type="checkbox"/> Other
4. Monitor Information... Manufacturer: Land Model Number: 4500 MK II + Serial Number: 9995460	
5. Installation Date:	6. Performance Specification Test Date:
7. Continuous Monitor Comment:  Monitor located at Fabric Filter outlet	

**Continuous Monitoring System:** Continuous Monitor 2 of 3

1. Parameter Code: EM, TEMP, FLOW	2. Pollutant(s): SO2, O2, Temperature, Steam Flow
3. CMS Requirement:	<input checked="" type="checkbox"/> Rule <input type="checkbox"/> Other
4. Monitor Information... Manufacturer: Sick Model Number: MCS100EHW Serial Number: 186	
5. Installation Date:	6. Performance Specification Test Date:
7. Continuous Monitor Comment:  Monitor located at SDA inlet	

**EMISSIONS UNIT INFORMATION**

Section [5] of [8]

**H. CONTINUOUS MONITOR INFORMATION (CONTINUED)**

**Continuous Monitoring System:** Continuous Monitor 3 of 3

1. Parameter Code: EM, TMP, FLOW	2. Pollutant(s): O2, NOx, CO, SO2, Temperature, Steam Flow
3. CMS Requirement:	<input checked="" type="checkbox"/> Rule <input type="checkbox"/> Other
4. Monitor Information... Manufacturer: Sick Model Number: MCS100EHW	Serial Number: 196
5. Installation Date:	6. Performance Specification Test Date:
7. Continuous Monitor Comment:  Monitor located at Fabric Filter outlet	

**Continuous Monitoring System:** Continuous Monitor \_\_\_ of \_\_\_

1. Parameter Code:	2. Pollutant(s):
3. CMS Requirement:	<input type="checkbox"/> Rule <input type="checkbox"/> Other
4. Monitor Information... Manufacturer: Model Number:	Serial Number:
5. Installation Date:	6. Performance Specification Test Date:
7. Continuous Monitor Comment:	

**EMISSIONS UNIT INFORMATION**

Section [5] of [8]

**I. EMISSIONS UNIT ADDITIONAL INFORMATION**

**Additional Requirements for All Applications, Except as Otherwise Stated**

1. Process Flow Diagram: (Required for all permit applications, except Title V air operation permit revision applications if this information was submitted to the department within the previous five years and would not be altered as a result of the revision being sought) <input checked="" type="checkbox"/> Attached, Document ID: <u>Appendix B</u> <input type="checkbox"/> Previously Submitted, Date _____
2. Fuel Analysis or Specification: (Required for all permit applications, except Title V air operation permit revision applications if this information was submitted to the department within the previous five years and would not be altered as a result of the revision being sought) <input checked="" type="checkbox"/> Attached, Document ID: <u>See Section 5</u> <input type="checkbox"/> Previously Submitted, Date _____
3. Detailed Description of Control Equipment: (Required for all permit applications, except Title V air operation permit revision applications if this information was submitted to the department within the previous five years and would not be altered as a result of the revision being sought) <input type="checkbox"/> Attached, Document ID: _____ <input checked="" type="checkbox"/> Previously Submitted, Date <u>December 2005</u>
4. Procedures for Startup and Shutdown: (Required for all operation permit applications, except Title V air operation permit revision applications if this information was submitted to the department within the previous five years and would not be altered as a result of the revision being sought) <input checked="" type="checkbox"/> Attached, Document ID: <u>Appendix C</u> <input type="checkbox"/> Previously Submitted, Date _____ <input type="checkbox"/> Not Applicable (construction application)
5. Operation and Maintenance Plan: (Required for all permit applications, except Title V air operation permit revision applications if this information was submitted to the department within the previous five years and would not be altered as a result of the revision being sought) <input checked="" type="checkbox"/> Attached, Document ID: <u>Appendix C</u> <input type="checkbox"/> Previously Submitted, Date _____ <input type="checkbox"/> Not Applicable
6. Compliance Demonstration Reports/Records: <input type="checkbox"/> Attached, Document ID: _____ Test Date(s)/Pollutant(s) Tested: _____ <input checked="" type="checkbox"/> Previously Submitted, Date: _____ Test Date(s)/Pollutant(s) Tested: <u>FY 2010 compliance testing results and 2009 Statement of Compliance are included in Appendix D.</u> <input type="checkbox"/> To be Submitted, Date (if known): _____ Test Date(s)/Pollutant(s) Tested: _____ <input type="checkbox"/> Not Applicable Note: For FESOP applications, all required compliance demonstration records/reports must be submitted at the time of application. For Title V air operation permit applications, all required compliance demonstration reports/records must be submitted at the time of application, or a compliance plan must be submitted at the time of application.
7. Other Information Required by Rule or Statute: <input type="checkbox"/> Attached, Document ID: _____ <input checked="" type="checkbox"/> Not Applicable

**EMISSIONS UNIT INFORMATION**

Section [5] of [8]

**I. EMISSIONS UNIT ADDITIONAL INFORMATION (CONTINUED)**

**Additional Requirements for Air Construction Permit Applications**

1. Control Technology Review and Analysis (Rules 62-212.400(10) and 62-212.500(7), F.A.C.; 40 CFR 63.43(d) and (e)): <input type="checkbox"/> Attached, Document ID: _____ <input checked="" type="checkbox"/> Not Applicable
2. Good Engineering Practice Stack Height Analysis (Rules 62-212.400(4)(d) and 62-212.500(4)(f), F.A.C.): <input type="checkbox"/> Attached, Document ID: _____ <input checked="" type="checkbox"/> Not Applicable
3. Description of Stack Sampling Facilities: (Required for proposed new stack sampling facilities only) <input type="checkbox"/> Attached, Document ID: _____ <input checked="" type="checkbox"/> Not Applicable

**Additional Requirements for Title V Air Operation Permit Applications**

1. Identification of Applicable Requirements: <input checked="" type="checkbox"/> Attached, Document ID: <u>See Section 4</u>
2. Compliance Assurance Monitoring: <input type="checkbox"/> Attached, Document ID: _____ <input checked="" type="checkbox"/> Not Applicable <u>See Section 4</u>
3. Alternative Methods of Operation: <input type="checkbox"/> Attached, Document ID: _____ <input checked="" type="checkbox"/> Not Applicable
4. Alternative Modes of Operation (Emissions Trading): <input type="checkbox"/> Attached, Document ID: _____ <input checked="" type="checkbox"/> Not Applicable

**Additional Requirements Comment**

None
------

**EMISSIONS UNIT INFORMATION**

Section [6] of [8]

**A. GENERAL EMISSIONS UNIT INFORMATION**

**Title V Air Operation Permit Emissions Unit Classification**

1. Regulated or Unregulated Emissions Unit? (Check one, if applying for an initial, revised or renewal Title V air operation permit. Skip this item if applying for an air construction permit or FESOP only.)

- The emissions unit addressed in this Emissions Unit Information Section is a regulated emissions unit.
- The emissions unit addressed in this Emissions Unit Information Section is an unregulated emissions unit.

**Emissions Unit Description and Status**

1. Type of Emissions Unit Addressed in this Section: (Check one)

- This Emissions Unit Information Section addresses, as a single emissions unit, a single process or production unit, or activity, which produces one or more air pollutants and which has at least one definable emission point (stack or vent).
- This Emissions Unit Information Section addresses, as a single emissions unit, a group of process or production units and activities which has at least one definable emission point (stack or vent) but may also produce fugitive emissions.
- This Emissions Unit Information Section addresses, as a single emissions unit, one or more process or production units and activities which produce fugitive emissions only.

2. Description of Emissions Unit Addressed in this Section:

Municipal Waste Combustors and Auxiliary Burners – Unit No. 3

3. Emissions Unit Identification Number: 105

4. Emissions Unit Status Code: A	5. Commence Construction Date:	6. Initial Startup Date: 08/30/2001	7. Emissions Unit Major Group SIC Code: 49
-------------------------------------	--------------------------------	--	--

8. Federal Program Applicability: (Check all that apply)

- Acid Rain Unit **Not Applicable**
- CAIR Unit

9. Package Unit:

Manufacturer: D.B. Riley

Model Number: 2759

10. Generator Nameplate Rating: 22.5 MW

11. Emissions Unit Comment:

Excess emissions are allowed during startup, shutdown, or malfunction, provided that the duration of these events does not exceed 3 hours per occurrence. For CO compliance, the duration of a malfunction period is limited to 15 hours per occurrence.



**EMISSIONS UNIT INFORMATION**

Section [6] of [8]

**Emissions Unit Control Equipment/Method:** Control 1 of 1

- |  |
|--|
| 1. Control Equipment/Method Description:<br>This emissions unit equipped with a spray dryer absorber (SDA), activated carbon injection system, fabric filter baghouse, and selective non-catalytic reduction (SNCR). |
| 2. Control Device or Method Code: 016, 048, 067, 107   |

**Emissions Unit Control Equipment/Method:** Control \_\_\_ of \_\_\_

- |  |
|--|
| 1. Control Equipment/Method Description: |
| 2. Control Device or Method Code:        |

**Emissions Unit Control Equipment/Method:** Control \_\_\_ of \_\_\_

- |  |
|--|
| 1. Control Equipment/Method Description: |
| 2. Control Device or Method Code:        |

**Emissions Unit Control Equipment/Method:** Control \_\_\_ of \_\_\_

- |  |
|--|
| 1. Control Equipment/Method Description: |
| 2. Control Device or Method Code:        |

**EMISSIONS UNIT INFORMATION**

Section [6] of [8]

**B. EMISSIONS UNIT CAPACITY INFORMATION**

(Optional for unregulated emissions units.)

**Emissions Unit Operating Capacity and Schedule**

1. Maximum Process or Throughput Rate:
2. Maximum Production Rate:
3. Maximum Heat Input Rate: million 120 MMBtu/hr (see item 6)
4. Maximum Incineration Rate: pounds/hr 288 tons/day
5. Requested Maximum Operating Schedule: 24 hours/day 7 days/week 52 weeks/year 8,760 hours/year
6. Operating Capacity/Schedule Comment:  120 MMBtu/hour heat input rate for information purposes only, not for compliance. Maximum steam flow and nominal capacity are limited by Limited by Florida permit PSD-FL-086(B).

**EMISSIONS UNIT INFORMATION**

Section [6] of [8]

**C. EMISSION POINT (STACK/VENT) INFORMATION****(Optional for unregulated emissions units.)****Emission Point Description and Type**

1. Identification of Point on Plot Plan or Flow Diagram: See Appendix A		2. Emission Point Type Code: 1	
3. Descriptions of Emission Points Comprising this Emissions Unit for VE Tracking:  <b>Not Applicable</b>			
4. ID Numbers or Descriptions of Emission Units with this Emission Point in Common:  <b>Not Applicable</b>			
5. Discharge Type Code: V	6. Stack Height: 201 feet	7. Exit Diameter: 4.2 feet	
8. Exit Temperature: 315 °F	9. Actual Volumetric Flow Rate: 60,894 acfm	10. Water Vapor: 20 % ±	
11. Maximum Dry Standard Flow Rate: 36,686 dscfm		12. Nonstack Emission Point Height: Feet	
13. Emission Point UTM Coordinates... Zone: 17 East (km): 360.0 North (km): 3091.9		14. Emission Point Latitude/Longitude... Latitude (DD/MM/SS) Longitude (DD/MM/SS)	
15. Emission Point Comment:  Four MWCs have separate stacks (flues) located within a common enclosure.			

**EMISSIONS UNIT INFORMATION**

Section [6] of [8]

**D. SEGMENT (PROCESS/FUEL) INFORMATION****Segment Description and Rate:** Segment 1 of 2

1. Segment Description (Process/Fuel Type):  Solid Waste Disposal – Government Municipal Incineration – Stationary Mass Burn Waterwall Combustor		
2. Source Classification Code (SCC): 50100105	3. SCC Units: Tons burned (all solid fuels)	
4. Maximum Hourly Rate: See item 10	5. Maximum Annual Rate: See item 10	6. Estimated Annual Activity Factor:
7. Maximum % Sulfur: N/A	8. Maximum % Ash: N/A	9. Million Btu per SCC Unit: 10 ±
10. Segment Comment:  PSD-FL-086(B) limits nominal heat input to 104 MMBtu/hr and nominal capacity to 250 tons per day (rolling 12-month average).		

**Segment Description and Rate:** Segment 2 of 2

1. Segment Description (Process/Fuel Type):  Solid Waste Disposal – Government Auxiliary Fuel/No Emissions – Natural Gas		
2. Source Classification Code (SCC): 50100106	3. SCC Units: Million Cubic Feet Burned (all gaseous fuels)	
4. Maximum Hourly Rate: See item 10	5. Maximum Annual Rate: See item 10	6. Estimated Annual Activity Factor:
7. Maximum % Sulfur:	8. Maximum % Ash:	9. Million Btu per SCC Unit: 1027 ±
10. Segment Comment:  PSD-FL-086(B) limits the maximum hourly rate by the 10% annual capacity factor.		

**EMISSIONS UNIT INFORMATION**

Section [6] of [8]

**E. EMISSIONS UNIT POLLUTANTS****List of Pollutants Emitted by Emissions Unit**

1. Pollutant Emitted	2. Primary Control Device Code	3. Secondary Control Device Code	4. Pollutant Regulatory Code
PM	016		EL
SO2	067	016	EL
NOx	107		EL
CO			EL
HCL (H106)	067	016	EL
H107	016		EL
PB	016		EL
H021	016		EL
H114	048		EL
DIOX	067	016	EL
H027	016		EL

**F1. EMISSIONS UNIT POLLUTANT DETAIL INFORMATION –  
POTENTIAL, FUGITIVE, AND ACTUAL EMISSIONS**  
(Optional for unregulated emissions units.)

Complete a Subsection F1 for each pollutant identified in Subsection E if applying for an air construction permit or concurrent processing of an air construction permit and a revised or renewal Title V operation permit. Complete for each emissions-limited pollutant identified in Subsection E if applying for an air operation permit.

**Potential, Estimated Fugitive, and Baseline & Projected Actual Emissions**

1. Pollutant Emitted: PM		2. Total Percent Efficiency of Control:	
3. Potential Emissions: 2.76 lb/hour                      12.1 tons/year		4. Synthetically Limited? <input type="checkbox"/> Yes <input checked="" type="checkbox"/> No	
5. Range of Estimated Fugitive Emissions (as applicable): to tons/year			
6. Emission Factor: 25 mg/dscm, corrected to 7% O2 Reference: Revised 40 CFR 60 Subpart Cb		7. Emissions Method Code: 0	
8.a. Baseline Actual Emissions (if required): tons/year		8.b. Baseline 24-month Period: From:                      To:	
9.a. Projected Actual Emissions (if required): tons/year		9.b. Projected Monitoring Period: <input type="checkbox"/> 5 years <input type="checkbox"/> 10 years	
10. Calculation of Emissions:  Limited by Florida permit PSD-FL-086(B) and revised 40 CFR 60 Subpart Cb			
11. Potential, Fugitive, and Actual Emissions Comment:  Limited by Florida permit PSD-FL-086(B). The current permitted emissions limit for PM is 27 mg/dscm and the revised 40 CFR 60 Subpart Cb limit is 25 mg/dscm.			

**F1. EMISSIONS UNIT POLLUTANT DETAIL INFORMATION –  
POTENTIAL, FUGITIVE, AND ACTUAL EMISSIONS**  
(Optional for unregulated emissions units.)

Complete a Subsection F1 for each pollutant identified in Subsection E if applying for an air construction permit or concurrent processing of an air construction permit and a revised or renewal Title V operation permit. Complete for each emissions-limited pollutant identified in Subsection E if applying for an air operation permit.

**Potential, Estimated Fugitive, and Baseline & Projected Actual Emissions**

1. Pollutant Emitted: SO2		2. Total Percent Efficiency of Control:	
3. Potential Emissions: lb/hour		4. Synthetically Limited? <input type="checkbox"/> Yes <input checked="" type="checkbox"/> No	
5. Range of Estimated Fugitive Emissions (as applicable): to tons/year			
6. Emission Factor: 29 ppmvd or 75% removal, corrected to 7% O2 Reference: PSD-FL-086(B)		7. Emissions Method Code: 0	
8.a. Baseline Actual Emissions (if required): tons/year		8.b. Baseline 24-month Period: From: To:	
9.a. Projected Actual Emissions (if required): tons/year		9.b. Projected Monitoring Period: <input type="checkbox"/> 5 years <input type="checkbox"/> 10 years	
10. Calculation of Emissions:  Limited by Florida permit PSD-FL-086(B)			
11. Potential, Fugitive, and Actual Emissions Comment:  Florida permit PSD-FL-086(B) limits SO2 emissions to 29 ppmvd or 25% of the potential sulfur dioxide emission (75% reduction by weight or volume), corrected to 7% O2, whichever is less stringent. Facility-wide SO2 emissions limited to 460 tons/year.			

**F1. EMISSIONS UNIT POLLUTANT DETAIL INFORMATION –  
POTENTIAL, FUGITIVE, AND ACTUAL EMISSIONS**

(Optional for unregulated emissions units.)

Complete a Subsection F1 for each pollutant identified in Subsection E if applying for an air construction permit or concurrent processing of an air construction permit and a revised or renewal Title V operation permit. Complete for each emissions-limited pollutant identified in Subsection E if applying for an air operation permit.

**Potential, Estimated Fugitive, and Baseline & Projected Actual Emissions**

1. Pollutant Emitted: NOx	2. Total Percent Efficiency of Control:
3. Potential Emissions: 40.1 lb/hour tons/year	4. Synthetically Limited? <input type="checkbox"/> Yes <input checked="checked" type="checkbox"/> No
5. Range of Estimated Fugitive Emissions (as applicable): to tons/year	
6. Emission Factor: 205 ppmvd, corrected to 7% O2 Reference: PSD-FL-086(B)	7. Emissions Method Code: 0
8.a. Baseline Actual Emissions (if required): tons/year	8.b. Baseline 24-month Period: From: To:
9.a. Projected Actual Emissions (if required): tons/year	9.b. Projected Monitoring Period: <input type="checkbox"/> 5 years <input type="checkbox"/> 10 years
10. Calculation of Emissions:  Limited by Florida permit PSD-FL-086(B)	
11. Potential, Fugitive, and Actual Emissions Comment:  Limited by Florida permit PSD-FL-086(B), which also contains additional emission limit of 0.335 lb/MMBtu. Facility-wide NOx emission limited to 679 tons/year.	



**F1. EMISSIONS UNIT POLLUTANT DETAIL INFORMATION –  
 POTENTIAL, FUGITIVE, AND ACTUAL EMISSIONS**  
 (Optional for unregulated emissions units.)

**Complete a Subsection F1 for each pollutant identified in Subsection E if applying for an air construction permit or concurrent processing of an air construction permit and a revised or renewal Title V operation permit. Complete for each emissions-limited pollutant identified in Subsection E if applying for an air operation permit.**

**Potential, Estimated Fugitive, and Baseline & Projected Actual Emissions**

1. Pollutant Emitted: CO		2. Total Percent Efficiency of Control:	
3. Potential Emissions: 11.91 lb/hour                      tons/year		4. Synthetically Limited? <input type="checkbox"/> Yes <input checked="" type="checkbox"/> No	
5. Range of Estimated Fugitive Emissions (as applicable): to tons/year			
6. Emission Factor: 100 ppmvd, corrected to 7% O2 Reference: PSD-FL-086(B)		7. Emissions Method Code: 0	
8.a. Baseline Actual Emissions (if required): tons/year		8.b. Baseline 24-month Period: From:                      To:	
9.a. Projected Actual Emissions (if required): tons/year		9.b. Projected Monitoring Period: <input type="checkbox"/> 5 years <input type="checkbox"/> 10 years	
10. Calculation of Emissions:  Limited by Florida permit PSD-FL-086(B)			
11. Potential, Fugitive, and Actual Emissions Comment:  Limited by Florida permit PSD-FL-086(B), which also contains additional emission limit of 0.0995 lb/MMBtu. Facility-wide CO emission limited to 185 tons/year.			

**F1. EMISSIONS UNIT POLLUTANT DETAIL INFORMATION –  
POTENTIAL, FUGITIVE, AND ACTUAL EMISSIONS**  
(Optional for unregulated emissions units.)

Complete a Subsection F1 for each pollutant identified in Subsection E if applying for an air construction permit or concurrent processing of an air construction permit and a revised or renewal Title V operation permit. Complete for each emissions-limited pollutant identified in Subsection E if applying for an air operation permit.

**Potential, Estimated Fugitive, and Baseline & Projected Actual Emissions**

1. Pollutant Emitted: HCL (H106)		2. Total Percent Efficiency of Control:	
3. Potential Emissions: lb/hour 67.9 tons/year		4. Synthetically Limited? <input type="checkbox"/> Yes <input checked="" type="checkbox"/> No	
5. Range of Estimated Fugitive Emissions (as applicable): to tons/year			
6. Emission Factor: 29 ppmvd or 95% removal, corrected to 7% O2 Reference: PSD-FL-086(B)		7. Emissions Method Code: 0	
8.a. Baseline Actual Emissions (if required): tons/year		8.b. Baseline 24-month Period: From: To:	
9.a. Projected Actual Emissions (if required): tons/year		9.b. Projected Monitoring Period: <input type="checkbox"/> 5 years <input type="checkbox"/> 10 years	
10. Calculation of Emissions:  Limited by Florida permit PSD-FL-086(B)			
11. Potential, Fugitive, and Actual Emissions Comment:  Limited by Florida permit PSD-FL-086(B) limits HCL emissions to 29 ppmvd or 5% of the potential sulfur dioxide emission (95% reduction by weight or volume), corrected to 7% O2, whichever is less stringent.			

**F1. EMISSIONS UNIT POLLUTANT DETAIL INFORMATION –  
POTENTIAL, FUGITIVE, AND ACTUAL EMISSIONS**  
(Optional for unregulated emissions units.)

**Complete a Subsection F1 for each pollutant identified in Subsection E if applying for an air construction permit or concurrent processing of an air construction permit and a revised or renewal Title V operation permit. Complete for each emissions-limited pollutant identified in Subsection E if applying for an air operation permit.**

**Potential, Estimated Fugitive, and Baseline & Projected Actual Emissions**

1. Pollutant Emitted: H107 (Fluoride as HF)		2. Total Percent Efficiency of Control: .	
3. Potential Emissions: 1.5 lb/hour                      6.57 tons/year		4. Synthetically Limited? <input type="checkbox"/> Yes <input checked="" type="checkbox"/> No	
5. Range of Estimated Fugitive Emissions (as applicable): to tons/year			
6. Emission Factor:  Reference: PSD-FL-086(B)		7. Emissions Method Code: 0	
8.a. Baseline Actual Emissions (if required): tons/year		8.b. Baseline 24-month Period: From:                      To:	
9.a. Projected Actual Emissions (if required): tons/year		9.b. Projected Monitoring Period: <input type="checkbox"/> 5 years <input type="checkbox"/> 10 years	
10. Calculation of Emissions:  Limited by Florida permit PSD-FL-086(B)			
11. Potential, Fugitive, and Actual Emissions Comment:  Limited by Florida permit PSD-FL-086(B), which also contains additional emission limit of 0.0125 lb/MMBtu.			

**F1. EMISSIONS UNIT POLLUTANT DETAIL INFORMATION –  
POTENTIAL, FUGITIVE, AND ACTUAL EMISSIONS**

(Optional for unregulated emissions units.)

Complete a Subsection F1 for each pollutant identified in Subsection E if applying for an air construction permit or concurrent processing of an air construction permit and a revised or renewal Title V operation permit. Complete for each emissions-limited pollutant identified in Subsection E if applying for an air operation permit.

**Potential, Estimated Fugitive, and Baseline & Projected Actual Emissions**

1. Pollutant Emitted: PB		2. Total Percent Efficiency of Control:	
3. Potential Emissions: 0.0451 lb/hour      0.197 tons/year		4. Synthetically Limited? <input type="checkbox"/> Yes <input checked="" type="checkbox"/> No	
5. Range of Estimated Fugitive Emissions (as applicable): to tons/year			
6. Emission Factor: 0.40 mg/dscm, corrected to 7% O2 Reference: Revised 40 CFR 60 Subpart Cb		7. Emissions Method Code: 0	
8.a. Baseline Actual Emissions (if required): tons/year		8.b. Baseline 24-month Period: From:                      To:	
9.a. Projected Actual Emissions (if required): tons/year		9.b. Projected Monitoring Period: <input type="checkbox"/> 5 years <input type="checkbox"/> 10 years	
10. Calculation of Emissions:  Limited by Florida permit PSD-FL-086(B) and revised 40 CFR 60 Subpart Cb			
11. Potential, Fugitive, and Actual Emissions Comment:  Limited by Florida permit PSD-FL-086(B), which also contains additional emission limit of 3.76E-04 lb/MMBtu. The current permitted emissions limit for lead is 0.44 mg/dscm and the revised 40 CFR 60 Subpart Cb limit is 0.40 mg/dscm			

**F1. EMISSIONS UNIT POLLUTANT DETAIL INFORMATION –  
 POTENTIAL, FUGITIVE, AND ACTUAL EMISSIONS  
 (Optional for unregulated emissions units.)**

**Complete a Subsection F1 for each pollutant identified in Subsection E if applying for an air construction permit or concurrent processing of an air construction permit and a revised or renewal Title V operation permit. Complete for each emissions-limited pollutant identified in Subsection E if applying for an air operation permit.**

**Potential, Estimated Fugitive, and Baseline & Projected Actual Emissions**

1. Pollutant Emitted: H021 (Beryllium Compounds)		2. Total Percent Efficiency of Control:	
3. Potential Emissions: 0.000115 lb/hour 5.04E-04 tons/year		4. Synthetically Limited? <input type="checkbox"/> Yes <input checked="" type="checkbox"/> No	
5. Range of Estimated Fugitive Emissions (as applicable): to tons/year			
6. Emission Factor:  Reference: PSD-FL-086(B)		7. Emissions Method Code: 0	
8.a. Baseline Actual Emissions (if required): tons/year		8.b. Baseline 24-month Period: From: To:	
9.a. Projected Actual Emissions (if required): tons/year		9.b. Projected Monitoring Period: <input type="checkbox"/> 5 years <input type="checkbox"/> 10 years	
10. Calculation of Emissions:  Limited by Florida permit PSD-FL-086(B)			
11. Potential, Fugitive, and Actual Emissions Comment:  Limited by Florida permit PSD-FL-086(B), which also contains additional emission limit of 9.58E-07 lb/MMBtu.			

**F1. EMISSIONS UNIT POLLUTANT DETAIL INFORMATION –  
 POTENTIAL, FUGITIVE, AND ACTUAL EMISSIONS**  
 (Optional for unregulated emissions units.)

Complete a Subsection F1 for each pollutant identified in Subsection E if applying for an air construction permit or concurrent processing of an air construction permit and a revised or renewal Title V operation permit. Complete for each emissions-limited pollutant identified in Subsection E if applying for an air operation permit.

**Potential, Estimated Fugitive, and Baseline & Projected Actual Emissions**

1. Pollutant Emitted: H114 (Mercury Compounds)		2. Total Percent Efficiency of Control:	
3. Potential Emissions: lb/hour                      0.0605 tons/year		4. Synthetically Limited? <input type="checkbox"/> Yes <input checked="" type="checkbox"/> No	
5. Range of Estimated Fugitive Emissions (as applicable): to tons/year			
6. Emission Factor: 0.050 mg/dscm or 85% reduction, corrected to 7% O <sub>2</sub>  Reference: Revised 40 CFR 60 Subpart Cb		7. Emissions Method Code: 0	
8.a. Baseline Actual Emissions (if required): tons/year		8.b. Baseline 24-month Period: From:                      To:	
9.a. Projected Actual Emissions (if required): tons/year		9.b. Projected Monitoring Period: <input type="checkbox"/> 5 years <input type="checkbox"/> 10 years	
10. Calculation of Emissions:  Limited by Florida permit PSD-FL-086(B) and revised 40 CFR 60 Subpart Cb			
11. Potential, Fugitive, and Actual Emissions Comment:  Limited by Florida permit PSD-FL-086(B) limits H114 emissions to 0.070 mg/dscm or 15% of the potential mercury emission concentration (85% reduction by weight or volume), corrected to 7% O <sub>2</sub> , whichever is less stringent. The current permitted emissions limit for mercury is 0.070 mg/dscm and the revised 40 CFR 60 Subpart Cb limit is 0.050 mg/dscm			

**F1. EMISSIONS UNIT POLLUTANT DETAIL INFORMATION –  
 POTENTIAL, FUGITIVE, AND ACTUAL EMISSIONS**  
 (Optional for unregulated emissions units.)

Complete a Subsection F1 for each pollutant identified in Subsection E if applying for an air construction permit or concurrent processing of an air construction permit and a revised or renewal Title V operation permit. Complete for each emissions-limited pollutant identified in Subsection E if applying for an air operation permit.

**Potential, Estimated Fugitive, and Baseline & Projected Actual Emissions**

1. Pollutant Emitted: DIOX		2. Total Percent Efficiency of Control:	
3. Potential Emissions: 3.07E-06 lb/hour 1.35E-05 tons/year		4. Synthetically Limited? <input type="checkbox"/> Yes <input checked="" type="checkbox"/> No	
5. Range of Estimated Fugitive Emissions (as applicable): to tons/year			
6. Emission Factor: 30 ng/dscm (total mass), corrected to 7% O2 Reference: PSD-FL-086(B)		7. Emissions Method Code: 0	
8.a. Baseline Actual Emissions (if required): tons/year		8.b. Baseline 24-month Period: From: To:	
9.a. Projected Actual Emissions (if required): tons/year		9.b. Projected Monitoring Period: <input type="checkbox"/> 5 years <input type="checkbox"/> 10 years	
10. Calculation of Emissions:  Limited by Florida permit PSD-FL-086(B)			
11. Potential, Fugitive, and Actual Emissions Comment:  Limited by Florida permit PSD-FL-086(B), which also contains additional emission limit of 2.56E-08 lb/MMBtu.			

**F1. EMISSIONS UNIT POLLUTANT DETAIL INFORMATION –  
POTENTIAL, FUGITIVE, AND ACTUAL EMISSIONS**  
(Optional for unregulated emissions units.)

**Complete a Subsection F1 for each pollutant identified in Subsection E if applying for an air construction permit or concurrent processing of an air construction permit and a revised or renewal Title V operation permit. Complete for each emissions-limited pollutant identified in Subsection E if applying for an air operation permit.**

**Potential, Estimated Fugitive, and Baseline & Projected Actual Emissions**

1. Pollutant Emitted: H027 (Cadmium Compounds)		2. Total Percent Efficiency of Control:	
3. Potential Emissions: 4.10E-03 lb/hour      0.0179 tons/year		4. Synthetically Limited? <input type="checkbox"/> Yes <input checked="" type="checkbox"/> No	
5. Range of Estimated Fugitive Emissions (as applicable): to tons/year			
6. Emission Factor: 0.035 mg/dscm, corrected to 7% O2 Reference: Revised 40 CFR 60 Subpart Cb		7. Emissions Method Code: 0	
8.a. Baseline Actual Emissions (if required): tons/year		8.b. Baseline 24-month Period: From:                      To:	
9.a. Projected Actual Emissions (if required): tons/year		9.b. Projected Monitoring Period: <input type="checkbox"/> 5 years <input type="checkbox"/> 10 years	
10. Calculation of Emissions:  Limited by Florida permit PSD-FL-086(B) and revised 40 CFR 60 Subpart Cb			
11. Potential, Fugitive, and Actual Emissions Comment:  Limited by Florida permit PSD-FL-086(B), which also contains additional emission limit of 3.24E-05 lb/MMBtu. The current permitted emissions limit for cadmium is 0.040 mg/dscm and the revised 40 CFR 60 Subpart Cb limit is 0.035 mg/dscm.			



**F2. EMISSIONS UNIT POLLUTANT DETAIL INFORMATION -  
 ALLOWABLE EMISSIONS**

**Complete Subsection F2 if the pollutant identified in Subsection F1 is or would be subject to a numerical emissions limitation.**

**Allowable Emissions** Allowable Emissions 1 of 11

1. Basis for Allowable Emissions Code: RULE	2. Future Effective Date of Allowable Emissions:
3. Allowable Emissions and Units: 25 mg/dscm, corrected to 7% O <sub>2</sub>	4. Equivalent Allowable Emissions: 2.76 lb/hour          12.1 tons/year
5. Method of Compliance: Compliance with PM emission limits will be demonstrated annually using EPA Reference Method 5.	
6. Allowable Emissions Comment (Description of Operating Method): Limited by Florida permit PSD-FL-086(B). The revised 40 CFR 60 Subpart Cb limit for PM is 25 mg/dscm.	

**Allowable Emissions** Allowable Emissions 2 of 11

1. Basis for Allowable Emissions Code: RULE	2. Future Effective Date of Allowable Emissions:
3. Allowable Emissions and Units: 29 ppmvd or 75% reduction, corrected to 7% O <sub>2</sub>	4. Equivalent Allowable Emissions: lb/hour          tons/year
5. Method of Compliance: Compliance with SO <sub>2</sub> emission limits will be demonstrated via CEMS using EPA Reference Method 19 to calculate the daily geometric average SO <sub>2</sub> concentration.	
6. Allowable Emissions Comment (Description of Operating Method): Florida permit PSD-FL-086(B) limits SO <sub>2</sub> emissions to 29 ppmvd or 25% of the potential sulfur dioxide emission (75% reduction by weight or volume), corrected to 7% O <sub>2</sub> , whichever is less stringent. Facility-wide SO <sub>2</sub> emission limited to 460 tons/year.	

**Allowable Emissions** Allowable Emissions 3 of 11

1. Basis for Allowable Emissions Code: RULE	2. Future Effective Date of Allowable Emissions:
3. Allowable Emissions and Units: 205 ppmvd, corrected to 7% O <sub>2</sub>	4. Equivalent Allowable Emissions: 40.1 lb/hour          tons/year
5. Method of Compliance: Compliance with NO <sub>x</sub> emission limits will be demonstrated via CEMS using EPA Reference Method 19 to calculate the daily arithmetic average NO <sub>x</sub> concentration.	
6. Allowable Emissions Comment (Description of Operating Method): Limited by Florida permit PSD-FL-086(B). Facility-wide NO <sub>x</sub> emissions limited to 679 tons/year.	

**F2. EMISSIONS UNIT POLLUTANT DETAIL INFORMATION --  
 ALLOWABLE EMISSIONS**

**Complete Subsection F2 if the pollutant identified in Subsection F1 is or would be subject to a numerical emissions limitation.**

**Allowable Emissions** Allowable Emissions 4 of 11

1. Basis for Allowable Emissions Code: RULE	2. Future Effective Date of Allowable Emissions:
3. Allowable Emissions and Units: 100 ppmvd, corrected to 7% O2	4. Equivalent Allowable Emissions: 11.9 lb/hour          tons/year
5. Method of Compliance: Compliance with CO emission limits will be demonstrated via CEMS using a 4-hour block average.	
6. Allowable Emissions Comment (Description of Operating Method): Limited by Florida permit PSD-FL-086(B). Facility-wide CO emissions limited to 185 tons/year.	

**Allowable Emissions** Allowable Emissions 5 of 11

1. Basis for Allowable Emissions Code: RULE	2. Future Effective Date of Allowable Emissions:
3. Allowable Emissions and Units: 29 ppmvd or 95% removal, corrected to 7% O2	4. Equivalent Allowable Emissions: lb/hour          67.9 tons/year
5. Method of Compliance: Compliance with HCL emission limits will be demonstrated annually using EPA Reference Method 26 or 26A.	
6. Allowable Emissions Comment (Description of Operating Method): Florida permit PSD-FL-086(B) limits SO2 emissions to 29 ppmvd or 5% of the potential sulfur dioxide emission (95% reduction by weight or volume), corrected to 7% O2, whichever is less stringent.	

**Allowable Emissions** Allowable Emissions 6 of 11

1. Basis for Allowable Emissions Code: RULE	2. Future Effective Date of Allowable Emissions:
3. Allowable Emissions and Units: 1.5 lb/hour	4. Equivalent Allowable Emissions: lb/hour          6.57 tons/year
5. Method of Compliance: Compliance with H107 (Fluoride as HF) emission limits will be demonstrated every 5 years using EPA Reference Method 13A or 13B.	
6. Allowable Emissions Comment (Description of Operating Method): Limited by Florida permit PSD-FL-086(B), which also contains additional emission limit of 0.0125 lb/MMBtu.	

**F2. EMISSIONS UNIT POLLUTANT DETAIL INFORMATION -  
ALLOWABLE EMISSIONS**

**Complete Subsection F2 if the pollutant identified in Subsection F1 is or would be subject to a numerical emissions limitation.**

**Allowable Emissions** Allowable Emissions 7 of 11

1. Basis for Allowable Emissions Code: RULE	2. Future Effective Date of Allowable Emissions:
3. Allowable Emissions and Units: 0.40 mg/dscm, corrected to 7% O <sub>2</sub>	4. Equivalent Allowable Emissions: 0.0451 lb/hour 0.197 tons/year
5. Method of Compliance: Compliance with PB emission limits will be demonstrated annually using EPA Reference Method 29.	
6. Allowable Emissions Comment (Description of Operating Method): Limited by Florida permit PSD-FL-086(B), which also contains additional emission limit of 3.76E-04 lb/MMBtu. The revised 40 CFR 60 Subpart Cb limit for lead is 0.40 mg/dscm.	

**Allowable Emissions** Allowable Emissions 8 of 11

1. Basis for Allowable Emissions Code: RULE	2. Future Effective Date of Allowable Emissions:
3. Allowable Emissions and Units: 0.000115lb/hr	4. Equivalent Allowable Emissions: lb/hour 5.04E-04 tons/year
5. Method of Compliance: Compliance with H021 (Beryllium Compounds) emission limits will be demonstrated every 5 years using EPA Reference Method 29.	
6. Allowable Emissions Comment (Description of Operating Method): Limited by Florida permit PSD-FL-086(B), which also contains additional emission limit of 9.58E-07 lb/MMBtu.	

**Allowable Emissions** Allowable Emissions 9 of 11

1. Basis for Allowable Emissions Code: RULE	2. Future Effective Date of Allowable Emissions:
3. Allowable Emissions and Units: 0.050 mg/dscm or 85% removal, @ 7% O <sub>2</sub>	4. Equivalent Allowable Emissions: lb/hour 0.0605 tons/year
5. Method of Compliance: Compliance with H114 (Mercury Compounds) emission limits will be demonstrated annually using EPA Reference Method 29.	
6. Allowable Emissions Comment (Description of Operating Method): Florida permit PSD-FL-086(B) limits H114 emissions to 0.070 mg/dscm or 15% of the potential mercury emission concentration (85% reduction by weigh or volume), corrected to 7% O <sub>2</sub> , whichever is less stringent. The revised 40 CFR 60 Subpart Cb limit for mercury is 0.050 mg/dscm.	

**F2. EMISSIONS UNIT POLLUTANT DETAIL INFORMATION -  
 ALLOWABLE EMISSIONS**

**Complete Subsection F2 if the pollutant identified in Subsection F1 is or would be subject to a numerical emissions limitation.**

**Allowable Emissions** Allowable Emissions 10 of 11

1. Basis for Allowable Emissions Code: RULE	2. Future Effective Date of Allowable Emissions:
3. Allowable Emissions and Units: 30 ng/dscm (total mass), corrected to 7% O2	4. Equivalent Allowable Emissions: 3.07E-06 lb/hour 1.35E-05 tons/year
5. Method of Compliance: Compliance with DOIX emission limits will be demonstrated annually using EPA Reference Method 23.	
6. Allowable Emissions Comment (Description of Operating Method): Limited by Florida permit PSD-FL-086(B), which also contains additional emission limit of 2.56E-08 lb/MMBtu.	

**Allowable Emissions** Allowable Emissions 11 of 11

1. Basis for Allowable Emissions Code: RULE	2. Future Effective Date of Allowable Emissions:
3. Allowable Emissions and Units: 0.035 mg/dscm, corrected to 7% O2	4. Equivalent Allowable Emissions: 4.10E-03 lb/hour 0.0179 tons/year 3.42E-05 lb/MMBtu
5. Method of Compliance: Compliance with H 027 (Cadmium Compounds) emission limits will be demonstrated annually using EPA Reference Method 29.	
6. Allowable Emissions Comment (Description of Operating Method): Florida permit PSD-FL-086(B). The revised 40 CFR 60 Subpart Cb limit for cadmium is 0.035 mg/dscm.	

**EMISSIONS UNIT INFORMATION**

Section [6] of [8]

**G. VISIBLE EMISSIONS INFORMATION**

Complete Subsection G if this emissions unit is or would be subject to a unit-specific visible emissions limitation.

**Visible Emissions Limitation:** Visible Emissions Limitation 1 of 1

1. Visible Emissions Subtype: VE10	2. Basis for Allowable Opacity: <input checked="" type="checkbox"/> Rule <input type="checkbox"/> Other
3. Allowable Opacity: Normal Conditions: 10 %      Exceptional Conditions: 100 % Maximum Period of Excess Opacity Allowed: 3 hours	
4. Method of Compliance: EPA Reference Method 9 shall be used to demonstrate compliance with the opacity limit except as provided under 40 CFR 60.11(e).	
5. Visible Emissions Comment: Excess emissions are allowed during startup, shutdown, or malfunction, provided that the duration of these events does not exceed 3 hours (40 CFR 60.56(b)).	

**Visible Emissions Limitation:** Visible Emissions Limitation    of   

1. Visible Emissions Subtype:	2. Basis for Allowable Opacity: <input type="checkbox"/> Rule <input type="checkbox"/> Other
3. Allowable Opacity: Normal Conditions: %      Exceptional Conditions: % Maximum Period of Excess Opacity Allowed: min/hour	
4. Method of Compliance:	
5. Visible Emissions Comment:	

**EMISSIONS UNIT INFORMATION**

Section [6] of [8]

**H. CONTINUOUS MONITOR INFORMATION****Complete Subsection H if this emissions unit is or would be subject to continuous monitoring.****Continuous Monitoring System:** Continuous Monitor 1 of 3

1. Parameter Code: VE	2. Pollutant(s): Visible Emissions (Opacity)
3. CMS Requirement:	<input type="checkbox"/> Rule <input type="checkbox"/> Other
4. Monitor Information... Manufacturer: Land Model Number: 4500 MK II + Serial Number: 0095471	
5. Installation Date:	6. Performance Specification Test Date:
7. Continuous Monitor Comment:  Monitor located at Fabric Filter outlet	

**Continuous Monitoring System:** Continuous Monitor 2 of 3

1. Parameter Code: EM, TEMP, FLOW	2. Pollutant(s): SO2, O2, Temperature, Steam Flow
3. CMS Requirement:	<input checked="" type="checkbox"/> Rule <input type="checkbox"/> Other
4. Monitor Information... Manufacturer: Sick Model Number: MCS100EHW Serial Number: 185	
5. Installation Date:	6. Performance Specification Test Date:
7. Continuous Monitor Comment:  Monitor located at SDA inlet	

**EMISSIONS UNIT INFORMATION**

Section [6] of [8]

**H. CONTINUOUS MONITOR INFORMATION (CONTINUED)**

**Continuous Monitoring System:** Continuous Monitor 3 of 3

1. Parameter Code: EM, TMP, FLOW	2. Pollutant(s): O2, NOx, CO, SO2, Temperature, Steam Flow
3. CMS Requirement:	<input checked="" type="checkbox"/> Rule <input type="checkbox"/> Other
4. Monitor Information... Manufacturer: Sick Model Number: MCS100EHW Serial Number: 195	
5. Installation Date:	6. Performance Specification Test Date:
7. Continuous Monitor Comment:  Monitor located at Fabric Filter outlet	

**Continuous Monitoring System:** Continuous Monitor \_\_\_ of \_\_\_

1. Parameter Code:	2. Pollutant(s):
3. CMS Requirement:	<input type="checkbox"/> Rule <input type="checkbox"/> Other
4. Monitor Information... Manufacturer: Model Number: Serial Number:	
5. Installation Date:	6. Performance Specification Test Date:
7. Continuous Monitor Comment:	

**EMISSIONS UNIT INFORMATION**

Section [6] of [8]

**I. EMISSIONS UNIT ADDITIONAL INFORMATION**

**Additional Requirements for All Applications, Except as Otherwise Stated**

1. Process Flow Diagram: (Required for all permit applications, except Title V air operation permit revision applications if this information was submitted to the department within the previous five years and would not be altered as a result of the revision being sought) <input checked="" type="checkbox"/> Attached, Document ID: <u>Appendix B</u> <input type="checkbox"/> Previously Submitted, Date _____
2. Fuel Analysis or Specification: (Required for all permit applications, except Title V air operation permit revision applications if this information was submitted to the department within the previous five years and would not be altered as a result of the revision being sought) <input checked="" type="checkbox"/> Attached, Document ID: <u>See Section 5</u> <input type="checkbox"/> Previously Submitted, Date _____
3. Detailed Description of Control Equipment: (Required for all permit applications, except Title V air operation permit revision applications if this information was submitted to the department within the previous five years and would not be altered as a result of the revision being sought) <input type="checkbox"/> Attached, Document ID: _____ <input checked="" type="checkbox"/> Previously Submitted, Date <u>December 2005</u>
4. Procedures for Startup and Shutdown: (Required for all operation permit applications, except Title V air operation permit revision applications if this information was submitted to the department within the previous five years and would not be altered as a result of the revision being sought) <input checked="" type="checkbox"/> Attached, Document ID: <u>Appendix C</u> <input type="checkbox"/> Previously Submitted, Date _____ <input type="checkbox"/> Not Applicable (construction application)
5. Operation and Maintenance Plan: (Required for all permit applications, except Title V air operation permit revision applications if this information was submitted to the department within the previous five years and would not be altered as a result of the revision being sought) <input checked="" type="checkbox"/> Attached, Document ID: <u>Appendix C</u> <input type="checkbox"/> Previously Submitted, Date _____ <input type="checkbox"/> Not Applicable
6. Compliance Demonstration Reports/Records: <input type="checkbox"/> Attached, Document ID: _____ Test Date(s)/Pollutant(s) Tested: _____ <input checked="" type="checkbox"/> Previously Submitted, Date: _____ Test Date(s)/Pollutant(s) Tested: <u>FY 2010 compliance testing results and 2009 Statement of Compliance are included in Appendix D.</u> <input type="checkbox"/> To be Submitted, Date (if known): _____ Test Date(s)/Pollutant(s) Tested: _____ <input type="checkbox"/> Not Applicable Note: For FESOP applications, all required compliance demonstration records/reports must be submitted at the time of application. For Title V air operation permit applications, all required compliance demonstration reports/records must be submitted at the time of application, or a compliance plan must be submitted at the time of application.
7. Other Information Required by Rule or Statute: <input type="checkbox"/> Attached, Document ID: _____ <input checked="" type="checkbox"/> Not Applicable



**EMISSIONS UNIT INFORMATION**

Section [6] of [8]

**I. EMISSIONS UNIT ADDITIONAL INFORMATION (CONTINUED)**

**Additional Requirements for Air Construction Permit Applications**

1. Control Technology Review and Analysis (Rules 62-212.400(10) and 62-212.500(7), F.A.C.; 40 CFR 63.43(d) and (e)): <input type="checkbox"/> Attached, Document ID: _____ <input checked="" type="checkbox"/> Not Applicable
2. Good Engineering Practice Stack Height Analysis (Rules 62-212.400(4)(d) and 62-212.500(4)(f), F.A.C.): <input type="checkbox"/> Attached, Document ID: _____ <input checked="" type="checkbox"/> Not Applicable
3. Description of Stack Sampling Facilities: (Required for proposed new stack sampling facilities only) <input type="checkbox"/> Attached, Document ID: _____ <input checked="" type="checkbox"/> Not Applicable

**Additional Requirements for Title V Air Operation Permit Applications**

1. Identification of Applicable Requirements: <input checked="" type="checkbox"/> Attached, Document ID: <u>See Section 4</u>
2. Compliance Assurance Monitoring: <input type="checkbox"/> Attached, Document ID: _____ <input checked="" type="checkbox"/> Not Applicable <u>See Section 4</u>
3. Alternative Methods of Operation: <input type="checkbox"/> Attached, Document ID: _____ <input checked="" type="checkbox"/> Not Applicable
4. Alternative Modes of Operation (Emissions Trading): <input type="checkbox"/> Attached, Document ID: _____ <input checked="" type="checkbox"/> Not Applicable

**Additional Requirements Comment**

None
------

# EMISSIONS UNIT INFORMATION

Section [7] of [8]

## A. GENERAL EMISSIONS UNIT INFORMATION

### Title V Air Operation Permit Emissions Unit Classification

1. Regulated or Unregulated Emissions Unit? (Check one, if applying for an initial, revised or renewal Title V air operation permit. Skip this item if applying for an air construction permit or FESOP only.)

The emissions unit addressed in this Emissions Unit Information Section is a regulated emissions unit.

The emissions unit addressed in this Emissions Unit Information Section is an unregulated emissions unit.

### Emissions Unit Description and Status

1. Type of Emissions Unit Addressed in this Section: (Check one)

This Emissions Unit Information Section addresses, as a single emissions unit, a single process or production unit, or activity, which produces one or more air pollutants and which has at least one definable emission point (stack or vent).

This Emissions Unit Information Section addresses, as a single emissions unit, a group of process or production units and activities which has at least one definable emission point (stack or vent) but may also produce fugitive emissions.

This Emissions Unit Information Section addresses, as a single emissions unit, one or more process or production units and activities which produce fugitive emissions only.

2. Description of Emissions Unit Addressed in this Section:

Municipal Waste Combustors and Auxiliary Burners – Unit No. 4

3. Emissions Unit Identification Number: 106

4. Emissions Unit Status Code:  
A

5. Commence Construction Date:

6. Initial Startup Date:  
08/30/2001

7. Emissions Unit Major Group SIC Code: 49

8. Federal Program Applicability: (Check all that apply)

Acid Rain Unit **Not Applicable**

CAIR Unit

9. Package Unit:

Manufacturer: D.B. Riley

Model Number: 2760

10. Generator Nameplate Rating: 22.5 MW

11. Emissions Unit Comment:

Excess emissions are allowed during startup, shutdown, or malfunction, provided that the duration of these events does not exceed 3 hours per occurrence. For CO compliance, the duration of a malfunction period is limited to 15 hours per occurrence.

**EMISSIONS UNIT INFORMATION**

**Section [7] of [8]**

**Emissions Unit Control Equipment/Method: Control 1 of 1**

- |  |
|--|
| 1. Control Equipment/Method Description:<br>This emissions unit equipped with a spray dryer absorber (SDA), activated carbon injection system, fabric filter baghouse, and selective non-catalytic reduction (SNCR). |
| 2. Control Device or Method Code: 016, 048, 067, 107   |

**Emissions Unit Control Equipment/Method: Control \_\_\_ of \_\_\_**

- |  |
|--|
| 1. Control Equipment/Method Description: |
| 2. Control Device or Method Code:        |

**Emissions Unit Control Equipment/Method: Control \_\_\_ of \_\_\_**

- |  |
|--|
| 1. Control Equipment/Method Description: |
| 2. Control Device or Method Code:        |

**Emissions Unit Control Equipment/Method: Control \_\_\_ of \_\_\_**

- |  |
|--|
| 1. Control Equipment/Method Description: |
| 2. Control Device or Method Code:        |

**EMISSIONS UNIT INFORMATION**

Section [7] of [8]

**B. EMISSIONS UNIT CAPACITY INFORMATION**

(Optional for unregulated emissions units.)

**Emissions Unit Operating Capacity and Schedule**

1. Maximum Process or Throughput Rate:
2. Maximum Production Rate:
3. Maximum Heat Input Rate: million 120 MMBtu/hr (see item 6)
4. Maximum Incineration Rate: pounds/hr 288 tons/day
5. Requested Maximum Operating Schedule: 24 hours/day 7 days/week 52 weeks/year 8,760 hours/year
6. Operating Capacity/Schedule Comment:  120 MMBtu/hour heat input rate for information purposes only, not for compliance. Maximum steam flow and nominal capacity are limited by Limited by Florida permit PSD-FL-086(B).

**EMISSIONS UNIT INFORMATION**

Section [7] of [8]

**C. EMISSION POINT (STACK/VENT) INFORMATION****(Optional for unregulated emissions units.)****Emission Point Description and Type**

1. Identification of Point on Plot Plan or Flow Diagram: See Appendix A		2. Emission Point Type Code: 1	
3. Descriptions of Emission Points Comprising this Emissions Unit for VE Tracking:  <b>Not Applicable</b>			
4. ID Numbers or Descriptions of Emission Units with this Emission Point in Common:  <b>Not Applicable</b>			
5. Discharge Type Code: V	6. Stack Height: 201 feet	7. Exit Diameter: 4.2 feet	
8. Exit Temperature: 315 °F	9. Actual Volumetric Flow Rate: 60,894 acfm	10. Water Vapor: 20 % ±	
11. Maximum Dry Standard Flow Rate: 36,686 dscfm		12. Nonstack Emission Point Height: Feet	
13. Emission Point UTM Coordinates... Zone: 17 East (km): 360.0 North (km): 3091.9		14. Emission Point Latitude/Longitude... Latitude (DD/MM/SS) Longitude (DD/MM/SS)	
15. Emission Point Comment:  Four MWCs have separate stacks (flues) located within a common enclosure.			

**EMISSIONS UNIT INFORMATION**

Section [7] of [8]

**D. SEGMENT (PROCESS/FUEL) INFORMATION**

**Segment Description and Rate:** Segment 1 of 2

1. Segment Description (Process/Fuel Type):  Solid Waste Disposal – Government Municipal Incineration – Stationary Mass Burn Waterwall Combustor		
2. Source Classification Code (SCC): 50100105	3. SCC Units: Tons burned (all solid fuels)	
4. Maximum Hourly Rate: See item 10	5. Maximum Annual Rate: See item 10	6. Estimated Annual Activity Factor:
7. Maximum % Sulfur: N/A	8. Maximum % Ash: N/A	9. Million Btu per SCC Unit: <b>10 ±</b>
10. Segment Comment:  PSD-FL-086(B) limits nominal heat input to 104 MMBtu/hr and nominal capacity to 250 tons per day (rolling 12-month average).		

**Segment Description and Rate:** Segment 2 of 2

1. Segment Description (Process/Fuel Type):  Solid Waste Disposal – Government Auxiliary Fuel/No Emissions – Natural Gas		
2. Source Classification Code (SCC): 50100106	3. SCC Units: Million Cubic Feet Burned (all gaseous fuels)	
4. Maximum Hourly Rate: See item 10	5. Maximum Annual Rate: See item 10	6. Estimated Annual Activity Factor:
7. Maximum % Sulfur:	8. Maximum % Ash:	9. Million Btu per SCC Unit: 1027 ±
10. Segment Comment:  PSD-FL-086(B) limits the maximum hourly rate by the 10% annual capacity factor.		

**EMISSIONS UNIT INFORMATION**

Section [7] of [8]

**E. EMISSIONS UNIT POLLUTANTS**

**List of Pollutants Emitted by Emissions Unit**

1. Pollutant Emitted	2. Primary Control Device Code	3. Secondary Control Device Code	4. Pollutant Regulatory Code
PM	016		EL
SO2	067	016	EL
NOx	107		EL
CO			EL
HCL (H106)	067	016	EL
H107	016		EL
PB	016		EL
H021	016		EL
H114	048		EL
DIOX	067	016	EL
H027	016		EL

**F1. EMISSIONS UNIT POLLUTANT DETAIL INFORMATION –  
 POTENTIAL, FUGITIVE, AND ACTUAL EMISSIONS**  
 (Optional for unregulated emissions units.)

Complete a Subsection F1 for each pollutant identified in Subsection E if applying for an air construction permit or concurrent processing of an air construction permit and a revised or renewal Title V operation permit. Complete for each emissions-limited pollutant identified in Subsection E if applying for an air operation permit.

**Potential, Estimated Fugitive, and Baseline & Projected Actual Emissions**

1. Pollutant Emitted: PM		2. Total Percent Efficiency of Control:	
3. Potential Emissions: 2.76 lb/hour                      12.1 tons/year		4. Synthetically Limited? <input type="checkbox"/> Yes <input checked="" type="checkbox"/> No	
5. Range of Estimated Fugitive Emissions (as applicable): to tons/year			
6. Emission Factor: 25 mg/dscm, corrected to 7% O2 Reference: Revised 40 CFR 60 Subpart Cb		7. Emissions Method Code: 0	
8.a. Baseline Actual Emissions (if required): tons/year		8.b. Baseline 24-month Period: From:                      To:	
9.a. Projected Actual Emissions (if required): tons/year		9.b. Projected Monitoring Period: <input type="checkbox"/> 5 years <input type="checkbox"/> 10 years	
10. Calculation of Emissions:  Limited by Florida permit PSD-FL-086(B) and revised 40 CFR 60 Subpart Cb			
11. Potential, Fugitive, and Actual Emissions Comment:  Limited by Florida permit PSD-FL-086(B). The current permitted emissions limit for PM is 27 mg/dscm and the revised 40 CFR 60 Subpart Cb limit is 25 mg/dscm.			



F1. EMISSIONS UNIT POLLUTANT DETAIL INFORMATION –  
 POTENTIAL, FUGITIVE, AND ACTUAL EMISSIONS

(Optional for unregulated emissions units.)

Complete a Subsection F1 for each pollutant identified in Subsection E if applying for an air construction permit or concurrent processing of an air construction permit and a revised or renewal Title V operation permit. Complete for each emissions-limited pollutant identified in Subsection E if applying for an air operation permit.

**Potential, Estimated Fugitive, and Baseline & Projected Actual Emissions**

1. Pollutant Emitted: SO2		2. Total Percent Efficiency of Control:	
3. Potential Emissions: lb/hour tons/year		4. Synthetically Limited? <input type="checkbox"/> Yes <input checked="" type="checkbox"/> No	
5. Range of Estimated Fugitive Emissions (as applicable): to tons/year			
6. Emission Factor: 29 ppmvd or 75% removal, corrected to 7% O2 Reference: PSD-FL-086(B)		7. Emissions Method Code: 0	
8.a. Baseline Actual Emissions (if required): tons/year		8.b. Baseline 24-month Period: From: To:	
9.a. Projected Actual Emissions (if required): tons/year		9.b. Projected Monitoring Period: <input type="checkbox"/> 5 years <input type="checkbox"/> 10 years	
10. Calculation of Emissions:  Limited by Florida permit PSD-FL-086(B)			
11. Potential, Fugitive, and Actual Emissions Comment:  Florida permit PSD-FL-086(B) limits SO2 emissions to 29 ppmvd or 25% of the potential sulfur dioxide emission (75% reduction by weight or volume), corrected to 7% O2, whichever is less stringent. Facility-wide SO2 emissions limited to 460 tons/year.			

**F1. EMISSIONS UNIT POLLUTANT DETAIL INFORMATION –  
 POTENTIAL, FUGITIVE, AND ACTUAL EMISSIONS**

(Optional for unregulated emissions units.)

Complete a Subsection F1 for each pollutant identified in Subsection E if applying for an air construction permit or concurrent processing of an air construction permit and a revised or renewal Title V operation permit. Complete for each emissions-limited pollutant identified in Subsection E if applying for an air operation permit.

**Potential, Estimated Fugitive, and Baseline & Projected Actual Emissions**

1. Pollutant Emitted: NO <sub>x</sub>		2. Total Percent Efficiency of Control:	
3. Potential Emissions: 40.1 lb/hour                                  tons/year		4. Synthetically Limited? <input type="checkbox"/> Yes <input checked="" type="checkbox"/> No	
5. Range of Estimated Fugitive Emissions (as applicable): to tons/year			
6. Emission Factor: 205 ppmvd, corrected to 7% O <sub>2</sub> Reference: PSD-FL-086(B)		7. Emissions Method Code: 0	
8.a. Baseline Actual Emissions (if required): tons/year		8.b. Baseline 24-month Period: From:                                  To:	
9.a. Projected Actual Emissions (if required): tons/year		9.b. Projected Monitoring Period: <input type="checkbox"/> 5 years <input type="checkbox"/> 10 years	
10. Calculation of Emissions:  Limited by Florida permit PSD-FL-086(B)			
11. Potential, Fugitive, and Actual Emissions Comment:  Limited by Florida permit PSD-FL-086(B), which also contains additional emission limit of 0.335 lb/MMBtu. Facility-wide NO <sub>x</sub> emission limited to 679 tons/year.			

**F1. EMISSIONS UNIT POLLUTANT DETAIL INFORMATION –  
 POTENTIAL, FUGITIVE, AND ACTUAL EMISSIONS**  
 (Optional for unregulated emissions units.)

Complete a Subsection F1 for each pollutant identified in Subsection E if applying for an air construction permit or concurrent processing of an air construction permit and a revised or renewal Title V operation permit. Complete for each emissions-limited pollutant identified in Subsection E if applying for an air operation permit.

**Potential, Estimated Fugitive, and Baseline & Projected Actual Emissions**

1. Pollutant Emitted: CO		2. Total Percent Efficiency of Control:	
3. Potential Emissions: 11.91 lb/hour tons/year		4. Synthetically Limited? <input type="checkbox"/> Yes <input checked="" type="checkbox"/> No	
5. Range of Estimated Fugitive Emissions (as applicable): to tons/year			
6. Emission Factor: 100 ppmvd, corrected to 7% O2 Reference: PSD-FL-086(B)		7. Emissions Method Code: 0	
8.a. Baseline Actual Emissions (if required): tons/year		8.b. Baseline 24-month Period: From: To:	
9.a. Projected Actual Emissions (if required): tons/year		9.b. Projected Monitoring Period: <input type="checkbox"/> 5 years <input type="checkbox"/> 10 years	
10. Calculation of Emissions:  Limited by Florida permit PSD-FL-086(B)			
11. Potential, Fugitive, and Actual Emissions Comment:  Limited by Florida permit PSD-FL-086(B), which also contains additional emission limit of 0.0995 lb/MMBtu. Facility-wide CO emission limited to 185 tons/year.			

**F1. EMISSIONS UNIT POLLUTANT DETAIL INFORMATION –  
 POTENTIAL, FUGITIVE, AND ACTUAL EMISSIONS**  
 (Optional for unregulated emissions units.)

**Complete a Subsection F1 for each pollutant identified in Subsection E if applying for an air construction permit or concurrent processing of an air construction permit and a revised or renewal Title V operation permit. Complete for each emissions-limited pollutant identified in Subsection E if applying for an air operation permit.**

**Potential, Estimated Fugitive, and Baseline & Projected Actual Emissions**

1. Pollutant Emitted: HCL (H106)		2. Total Percent Efficiency of Control:	
3. Potential Emissions: lb/hour 67.9 tons/year		4. Synthetically Limited? <input type="checkbox"/> Yes <input checked="" type="checkbox"/> No	
5. Range of Estimated Fugitive Emissions (as applicable): to tons/year			
6. Emission Factor: 29 ppmvd or 95% removal, corrected to 7% O2 Reference: PSD-FL-086(B)		7. Emissions Method Code: 0	
8.a. Baseline Actual Emissions (if required): tons/year		8.b. Baseline 24-month Period: From: To:	
9.a. Projected Actual Emissions (if required): tons/year		9.b. Projected Monitoring Period: <input type="checkbox"/> 5 years <input type="checkbox"/> 10 years	
10. Calculation of Emissions:  Limited by Florida permit PSD-FL-086(B)			
11. Potential, Fugitive, and Actual Emissions Comment:  Limited by Florida permit PSD-FL-086(B) limits HCL emissions to 29 ppmvd or 5% of the potential sulfur dioxide emission (95% reduction by weight or volume), corrected to 7% O2, whichever is less stringent.			

**F1. EMISSIONS UNIT POLLUTANT DETAIL INFORMATION –  
POTENTIAL, FUGITIVE, AND ACTUAL EMISSIONS**  
(Optional for unregulated emissions units.)

Complete a Subsection F1 for each pollutant identified in Subsection E if applying for an air construction permit or concurrent processing of an air construction permit and a revised or renewal Title V operation permit. Complete for each emissions-limited pollutant identified in Subsection E if applying for an air operation permit.

**Potential, Estimated Fugitive, and Baseline & Projected Actual Emissions**

1. Pollutant Emitted: H107 (Fluoride as HF)		2. Total Percent Efficiency of Control:	
3. Potential Emissions: 1.5 lb/hour                      6.57 tons/year		4. Synthetically Limited? <input type="checkbox"/> Yes <input checked="" type="checkbox"/> No	
5. Range of Estimated Fugitive Emissions (as applicable): to tons/year			
6. Emission Factor:  Reference: PSD-FL-086(B)		7. Emissions Method Code: 0	
8.a. Baseline Actual Emissions (if required): tons/year		8.b. Baseline 24-month Period: From:                      To:	
9.a. Projected Actual Emissions (if required): tons/year		9.b. Projected Monitoring Period: <input type="checkbox"/> 5 years <input type="checkbox"/> 10 years	
10. Calculation of Emissions:  Limited by Florida permit PSD-FL-086(B)			
11. Potential, Fugitive, and Actual Emissions Comment:  Limited by Florida permit PSD-FL-086(B), which also contains additional emission limit of 0.0125 lb/MMBtu.			

**F1. EMISSIONS UNIT POLLUTANT DETAIL INFORMATION –  
POTENTIAL, FUGITIVE, AND ACTUAL EMISSIONS**

(Optional for unregulated emissions units.)

Complete a Subsection F1 for each pollutant identified in Subsection E if applying for an air construction permit or concurrent processing of an air construction permit and a revised or renewal Title V operation permit. Complete for each emissions-limited pollutant identified in Subsection E if applying for an air operation permit.

**Potential, Estimated Fugitive, and Baseline & Projected Actual Emissions**

1. Pollutant Emitted: PB		2. Total Percent Efficiency of Control:	
3. Potential Emissions: 0.0451 lb/hour      0.197 tons/year		4. Synthetically Limited? <input type="checkbox"/> Yes <input checked="" type="checkbox"/> No	
5. Range of Estimated Fugitive Emissions (as applicable): to tons/year			
6. Emission Factor: 0.40 mg/dscm, corrected to 7% O <sub>2</sub> Reference: Revised 40 CFR 60 Subpart Cb		7. Emissions Method Code: 0	
8.a. Baseline Actual Emissions (if required): tons/year		8.b. Baseline 24-month Period: From:                      To:	
9.a. Projected Actual Emissions (if required): tons/year		9.b. Projected Monitoring Period: <input type="checkbox"/> 5 years <input type="checkbox"/> 10 years	
10. Calculation of Emissions:  Limited by Florida permit PSD-FL-086(B) and revised 40 CFR 60 Subpart Cb			
11. Potential, Fugitive, and Actual Emissions Comment:  Limited by Florida permit PSD-FL-086(B), which also contains additional emission limit of 3.76E-04 lb/MMBtu. The current permitted emissions limit for lead is 0.44 mg/dscm and the revised 40 CFR 60 Subpart Cb limit is 0.40 mg/dscm.			

**F1. EMISSIONS UNIT POLLUTANT DETAIL INFORMATION –  
POTENTIAL, FUGITIVE, AND ACTUAL EMISSIONS**  
(Optional for unregulated emissions units.)

Complete a Subsection F1 for each pollutant identified in Subsection E if applying for an air construction permit or concurrent processing of an air construction permit and a revised or renewal Title V operation permit. Complete for each emissions-limited pollutant identified in Subsection E if applying for an air operation permit.

**Potential, Estimated Fugitive, and Baseline & Projected Actual Emissions**

1. Pollutant Emitted: H021 (Beryllium Compounds)		2. Total Percent Efficiency of Control:	
3. Potential Emissions: 0.000115 lb/hour 5.04E-04 tons/year		4. Synthetically Limited? <input type="checkbox"/> Yes <input checked="" type="checkbox"/> No	
5. Range of Estimated Fugitive Emissions (as applicable): to tons/year			
6. Emission Factor: Reference: PSD-FL-086(B)		7. Emissions Method Code: 0	
8.a. Baseline Actual Emissions (if required): tons/year		8.b. Baseline 24-month Period: From: To:	
9.a. Projected Actual Emissions (if required): tons/year		9.b. Projected Monitoring Period: <input type="checkbox"/> 5 years <input type="checkbox"/> 10 years	
10. Calculation of Emissions:  Limited by Florida permit PSD-FL-086(B)			
11. Potential, Fugitive, and Actual Emissions Comment:  Limited by Florida permit PSD-FL-086(B), which also contains additional emission limit of 9.58E-07 lb/MMBtu.			

**F1. EMISSIONS UNIT POLLUTANT DETAIL INFORMATION –  
 POTENTIAL, FUGITIVE, AND ACTUAL EMISSIONS**  
 (Optional for unregulated emissions units.)

Complete a Subsection F1 for each pollutant identified in Subsection E if applying for an air construction permit or concurrent processing of an air construction permit and a revised or renewal Title V operation permit. Complete for each emissions-limited pollutant identified in Subsection E if applying for an air operation permit.

**Potential, Estimated Fugitive, and Baseline & Projected Actual Emissions**

1. Pollutant Emitted: H114 (Mercury Compounds)		2. Total Percent Efficiency of Control:	
3. Potential Emissions: lb/hour                      0.0605 tons/year		4. Synthetically Limited? <input type="checkbox"/> Yes <input checked="" type="checkbox"/> No	
5. Range of Estimated Fugitive Emissions (as applicable): to tons/year			
6. Emission Factor: 0.050 mg/dscm or 85% reduction, corrected to 7% O2  Reference: Revised 40 CFR 60 Subpart Cb		7. Emissions Method Code: 0	
8.a. Baseline Actual Emissions (if required): tons/year		8.b. Baseline 24-month Period: From:                      To:	
9.a. Projected Actual Emissions (if required): tons/year		9.b. Projected Monitoring Period: <input type="checkbox"/> 5 years <input type="checkbox"/> 10 years	
10. Calculation of Emissions:  Limited by Florida permit PSD-FL-086(B) and revised 40 CFR 60 Subpart Cb			
11. Potential, Fugitive, and Actual Emissions Comment:  Limited by Florida permit PSD-FL-086(B) limits H114 emissions to 0.070 mg/dscm or 15% of the potential mercury emission concentration (85% reduction by weight or volume), corrected to 7% O2, whichever is less stringent. The current permitted emissions limit for mercury is 0.070 mg/dscm and the revised 40 CFR 60 Subpart Cb limit is 0.050 mg/dscm.			



**F1. EMISSIONS UNIT POLLUTANT DETAIL INFORMATION –  
 POTENTIAL, FUGITIVE, AND ACTUAL EMISSIONS**  
 (Optional for unregulated emissions units.)

Complete a Subsection F1 for each pollutant identified in Subsection E if applying for an air construction permit or concurrent processing of an air construction permit and a revised or renewal Title V operation permit. Complete for each emissions-limited pollutant identified in Subsection E if applying for an air operation permit.

**Potential, Estimated Fugitive, and Baseline & Projected Actual Emissions**

1. Pollutant Emitted: DIOX		2. Total Percent Efficiency of Control:	
3. Potential Emissions: 3.07E-06 lb/hour 1.35E-05 tons/year		4. Synthetically Limited? <input type="checkbox"/> Yes <input checked="" type="checkbox"/> No	
5. Range of Estimated Fugitive Emissions (as applicable): to tons/year			
6. Emission Factor: 30 ng/dscm (total mass), corrected to 7% O2 Reference: PSD-FL-086(B)		7. Emissions Method Code: 0	
8.a. Baseline Actual Emissions (if required): tons/year		8.b. Baseline 24-month Period: From: To:	
9.a. Projected Actual Emissions (if required): tons/year		9.b. Projected Monitoring Period: <input type="checkbox"/> 5 years <input type="checkbox"/> 10 years	
10. Calculation of Emissions:  Limited by Florida permit PSD-FL-086(B)			
11. Potential, Fugitive, and Actual Emissions Comment:  Limited by Florida permit PSD-FL-086(B), which also contains additional emission limit of 2.56E-08 lb/MMBtu.			

**F1. EMISSIONS UNIT POLLUTANT DETAIL INFORMATION –  
 POTENTIAL, FUGITIVE, AND ACTUAL EMISSIONS**  
 (Optional for unregulated emissions units.)

Complete a Subsection F1 for each pollutant identified in Subsection E if applying for an air construction permit or concurrent processing of an air construction permit and a revised or renewal Title V operation permit. Complete for each emissions-limited pollutant identified in Subsection E if applying for an air operation permit.

**Potential, Estimated Fugitive, and Baseline & Projected Actual Emissions**

1. Pollutant Emitted: H027 (Cadmium Compounds)		2. Total Percent Efficiency of Control:	
3. Potential Emissions: 4.10E-03 lb/hour      0.0179 tons/year		4. Synthetically Limited? <input type="checkbox"/> Yes <input checked="" type="checkbox"/> No	
5. Range of Estimated Fugitive Emissions (as applicable): to tons/year			
6. Emission Factor: 0.035 mg/dscm, corrected to 7% O2 Reference: Revised 40 CFR 60 Subpart Cb		7. Emissions Method Code: 0	
8.a. Baseline Actual Emissions (if required): tons/year		8.b. Baseline 24-month Period: From:                      To:	
9.a. Projected Actual Emissions (if required): tons/year		9.b. Projected Monitoring Period: <input type="checkbox"/> 5 years <input type="checkbox"/> 10 years	
10. Calculation of Emissions:  Limited by Florida permit PSD-FL-086(B) and revised 40 CFR 60 Subpart Cb			
11. Potential, Fugitive, and Actual Emissions Comment:  Limited by Florida permit PSD-FL-086(B), which also contains additional emission limit of 3.24E-05 lb/MMBtu. The current permitted emissions limit for cadmium is 0.040 mg/dscm and the revised 40 CFR 60 Subpart Cb limit is 0.035 mg/dscm.			

**F2. EMISSIONS UNIT POLLUTANT DETAIL INFORMATION -  
 ALLOWABLE EMISSIONS**

**Complete Subsection F2 if the pollutant identified in Subsection F1 is or would be subject to a numerical emissions limitation.**

**Allowable Emissions** Allowable Emissions 1 of 11

1. Basis for Allowable Emissions Code: RULE	2. Future Effective Date of Allowable Emissions:
3. Allowable Emissions and Units: 25 mg/dscm, corrected to 7% O <sub>2</sub>	4. Equivalent Allowable Emissions: 2.76 lb/hour      12.1 tons/year
5. Method of Compliance: Compliance with PM emission limits will be demonstrated annually using EPA Reference Method 5.	
6. Allowable Emissions Comment (Description of Operating Method): Limited by Florida permit PSD-FL-086(B). The revised 40 CFR 60 Subpart Cb limit for PM is 25 mg/dscm.	

**Allowable Emissions** Allowable Emissions 2 of 11

1. Basis for Allowable Emissions Code: RULE	2. Future Effective Date of Allowable Emissions:
3. Allowable Emissions and Units: 29 ppmvd or 75% reduction, corrected to 7% O <sub>2</sub>	4. Equivalent Allowable Emissions: lb/hour      tons/year
5. Method of Compliance: Compliance with SO <sub>2</sub> emission limits will be demonstrated via CEMS using EPA Reference Method 19 to calculate the daily geometric average SO <sub>2</sub> concentration.	
6. Allowable Emissions Comment (Description of Operating Method): Florida permit PSD-FL-086(B) limits SO <sub>2</sub> emissions to 29 ppmvd or 25% of the potential sulfur dioxide emission (75% reduction by weight or volume), corrected to 7% O <sub>2</sub> , whichever is less stringent. Facility-wide SO <sub>2</sub> emission limited to 460 tons/year.	

**Allowable Emissions** Allowable Emissions 3 of 11

1. Basis for Allowable Emissions Code: RULE	2. Future Effective Date of Allowable Emissions:
3. Allowable Emissions and Units: 205 ppmvd, corrected to 7% O <sub>2</sub>	4. Equivalent Allowable Emissions: 40.1 lb/hour      tons/year
5. Method of Compliance: Compliance with NO <sub>x</sub> emission limits will be demonstrated via CEMS using EPA Reference Method 19 to calculate the daily arithmetic average NO <sub>x</sub> concentration.	
6. Allowable Emissions Comment (Description of Operating Method): Limited by Florida permit PSD-FL-086(B). Facility-wide NO <sub>x</sub> emissions limited to 679 tons/year.	

**F2. EMISSIONS UNIT POLLUTANT DETAIL INFORMATION -  
 ALLOWABLE EMISSIONS**

**Complete Subsection F2 if the pollutant identified in Subsection F1 is or would be subject to a numerical emissions limitation.**

**Allowable Emissions** Allowable Emissions 4 of 11

1. Basis for Allowable Emissions Code: RULE	2. Future Effective Date of Allowable Emissions:
3. Allowable Emissions and Units: 100 ppmvd, corrected to 7% O <sub>2</sub>	4. Equivalent Allowable Emissions: 11.9 lb/hour          tons/year
5. Method of Compliance: Compliance with CO emission limits will be demonstrated via CEMS using a 4-hour block average.	
6. Allowable Emissions Comment (Description of Operating Method): Limited by Florida permit PSD-FL-086(B). Facility-wide CO emissions limited to 185 tons/year.	

**Allowable Emissions** Allowable Emissions 5 of 11

1. Basis for Allowable Emissions Code: RULE	2. Future Effective Date of Allowable Emissions:
3. Allowable Emissions and Units: 29 ppmvd or 95% removal, corrected to 7% O <sub>2</sub>	4. Equivalent Allowable Emissions: lb/hour          67.9 tons/year
5. Method of Compliance: Compliance with HCL emission limits will be demonstrated annually using EPA Reference Method 26 or 26A.	
6. Allowable Emissions Comment (Description of Operating Method): Florida permit PSD-FL-086(B) limits SO <sub>2</sub> emissions to 29 ppmvd or 5% of the potential sulfur dioxide emission (95% reduction by weight or volume), corrected to 7% O <sub>2</sub> , whichever is less stringent.	

**Allowable Emissions** Allowable Emissions 6 of 11

1. Basis for Allowable Emissions Code: RULE	2. Future Effective Date of Allowable Emissions:
3. Allowable Emissions and Units: 1.5 lb/hour	4. Equivalent Allowable Emissions: lb/hour          6.57 tons/year
5. Method of Compliance: Compliance with H107 (Fluoride as HF) emission limits will be demonstrated every 5 years using EPA Reference Method 13A or 13B.	
6. Allowable Emissions Comment (Description of Operating Method): Limited by Florida permit PSD-FL-086(B), which also contains additional emission limit of 0.0125 lb/MMBtu.	

**F2. EMISSIONS UNIT POLLUTANT DETAIL INFORMATION -  
ALLOWABLE EMISSIONS**

**Complete Subsection F2 if the pollutant identified in Subsection F1 is or would be subject to a numerical emissions limitation.**

**Allowable Emissions** Allowable Emissions 7 of 11

1. Basis for Allowable Emissions Code: RULE	2. Future Effective Date of Allowable Emissions:
3. Allowable Emissions and Units: 0.40 mg/dscm, corrected to 7% O <sub>2</sub>	4. Equivalent Allowable Emissions: 0.0451 lb/hour 0.197 tons/year
5. Method of Compliance: Compliance with PB emission limits will be demonstrated annually using EPA Reference Method 29.	
6. Allowable Emissions Comment (Description of Operating Method): Limited by Florida permit PSD-FL-086(B), which also contains additional emission limit of 3.76E-04 lb/MMBtu. The revised 40 CFR 60 Subpart Cb limit for lead is 0.40 mg/dscm.	

**Allowable Emissions** Allowable Emissions 8 of 11

1. Basis for Allowable Emissions Code: RULE	2. Future Effective Date of Allowable Emissions:
3. Allowable Emissions and Units: 0.000115lb/hr	4. Equivalent Allowable Emissions: lb/hour 5.04E-04 tons/year
5. Method of Compliance: Compliance with H021 (Beryllium Compounds) emission limits will be demonstrated every 5 years using EPA Reference Method 29.	
6. Allowable Emissions Comment (Description of Operating Method): Limited by Florida permit PSD-FL-086(B), which also contains additional emission limit of 9.58E-07 lb/MMBtu.	

**Allowable Emissions** Allowable Emissions 9 of 11

1. Basis for Allowable Emissions Code: RULE	2. Future Effective Date of Allowable Emissions:
3. Allowable Emissions and Units: 0.050 mg/dscm or 85% removal, @ 7% O <sub>2</sub>	4. Equivalent Allowable Emissions: lb/hour 0.0605 tons/year
5. Method of Compliance: Compliance with H114 (Mercury Compounds) emission limits will be demonstrated annually using EPA Reference Method 29.	
6. Allowable Emissions Comment (Description of Operating Method): Florida permit PSD-FL-086(B) limits H114 emissions to 0.070 mg/dscm or 15% of the potential mercury emission concentration (85% reduction by weigh or volume), corrected to 7% O <sub>2</sub> , whichever is less stringent. The revised 40 CFR 60 Subpart Cb limit for mercury is 0.050 mg/dscm.	

**F2. EMISSIONS UNIT POLLUTANT DETAIL INFORMATION -  
 ALLOWABLE EMISSIONS**

**Complete Subsection F2 if the pollutant identified in Subsection F1 is or would be subject to a numerical emissions limitation.**

**Allowable Emissions** Allowable Emissions 10 of 11

1. Basis for Allowable Emissions Code: RULE	2. Future Effective Date of Allowable Emissions:
3. Allowable Emissions and Units: 30 ng/dscm (total mass), corrected to 7% O2	4. Equivalent Allowable Emissions: 3.07E-06 lb/hour 1.35E-05 tons/year
5. Method of Compliance: Compliance with DOIX emission limits will be demonstrated annually using EPA Reference Method 23.	
6. Allowable Emissions Comment (Description of Operating Method): Limited by Florida permit PSD-FL-086(B), which also contains additional emission limit of 2.56E-08 lb/MMBtu.	

**Allowable Emissions** Allowable Emissions 11 of 11

1. Basis for Allowable Emissions Code: RULE	2. Future Effective Date of Allowable Emissions:
3. Allowable Emissions and Units: 0.035 mg/dscm, corrected to 7% O2	4. Equivalent Allowable Emissions: 4.10E-03 lb/hour 0.0179 tons/year 3.42E-05 lb/MMBtu
5. Method of Compliance: Compliance with H 027 (Cadmium Compounds) emission limits will be demonstrated annually using EPA Reference Method 29.	
6. Allowable Emissions Comment (Description of Operating Method): Florida permit PSD-FL-086(B). The revised 40 CFR 60 Subpart Cb limit for cadmium is 0.035 mg/dscm.	

**EMISSIONS UNIT INFORMATION**

Section [7] of [8]

**G. VISIBLE EMISSIONS INFORMATION**

**Complete Subsection G if this emissions unit is or would be subject to a unit-specific visible emissions limitation.**

**Visible Emissions Limitation:** Visible Emissions Limitation 1 of 1

1. Visible Emissions Subtype: VE10	2. Basis for Allowable Opacity: <input checked="" type="checkbox"/> Rule <input type="checkbox"/> Other
3. Allowable Opacity: Normal Conditions: 10 %      Exceptional Conditions: 100 % Maximum Period of Excess Opacity Allowed: 3 hours	
4. Method of Compliance: EPA Reference Method 9 shall be used to demonstrate compliance with the opacity limit except as provided under 40 CFR 60.11(e).	
5. Visible Emissions Comment: Excess emissions are allowed during startup, shutdown, or malfunction, provided that the duration of these events does not exceed 3 hours (40 CFR 60.56(b)).	

**Visible Emissions Limitation:** Visible Emissions Limitation    of   

1. Visible Emissions Subtype:	2. Basis for Allowable Opacity: <input type="checkbox"/> Rule <input type="checkbox"/> Other
3. Allowable Opacity: Normal Conditions: %      Exceptional Conditions: % Maximum Period of Excess Opacity Allowed: min/hour	
4. Method of Compliance:	
5. Visible Emissions Comment:	

**EMISSIONS UNIT INFORMATION**

Section [7] of [8]

**H. CONTINUOUS MONITOR INFORMATION**

**Complete Subsection H if this emissions unit is or would be subject to continuous monitoring.**

**Continuous Monitoring System:** Continuous Monitor 1 of 3

1. Parameter Code: VE	2. Pollutant(s): Visible Emissions (Opacity)
3. CMS Requirement:	<input type="checkbox"/> Rule <input type="checkbox"/> Other
4. Monitor Information... Manufacturer: Land Model Number: 4500 MK II + Serial Number: 9995456	
5. Installation Date:	6. Performance Specification Test Date:
7. Continuous Monitor Comment:  Monitor located at Fabric Filter outlet	

**Continuous Monitoring System:** Continuous Monitor 2 of 3

1. Parameter Code: EM, TEMP, FLOW	2. Pollutant(s): SO2, O2, Temperature, Steam Flow
3. CMS Requirement:	<input checked="" type="checkbox"/> Rule <input type="checkbox"/> Other
4. Monitor Information... Manufacturer: Sick Model Number: MCS100EHW Serial Number: 184	
5. Installation Date:	6. Performance Specification Test Date:
7. Continuous Monitor Comment:  Monitor located at SDA inlet	



**EMISSIONS UNIT INFORMATION**

Section [7] of [8]

**H. CONTINUOUS MONITOR INFORMATION (CONTINUED)**

**Continuous Monitoring System:** Continuous Monitor 3 of 3

1. Parameter Code: EM, TMP, FLOW	2. Pollutant(s): O2, NOx, CO, SO2, Temperature, Steam Flow
3. CMS Requirement:	<input checked="" type="checkbox"/> Rule <input type="checkbox"/> Other
4. Monitor Information... Manufacturer: Sick Model Number: MCS100EHW Serial Number: 194	
5. Installation Date:	6. Performance Specification Test Date:
7. Continuous Monitor Comment:  Monitor located at Fabric Filter outlet	

**Continuous Monitoring System:** Continuous Monitor \_\_\_ of \_\_\_

1. Parameter Code:	2. Pollutant(s):
3. CMS Requirement:	<input type="checkbox"/> Rule <input type="checkbox"/> Other
4. Monitor Information... Manufacturer: Model Number: Serial Number:	
5. Installation Date:	6. Performance Specification Test Date:
7. Continuous Monitor Comment:	

**EMISSIONS UNIT INFORMATION**

Section [7] of [8]

**I. EMISSIONS UNIT ADDITIONAL INFORMATION**

**Additional Requirements for All Applications, Except as Otherwise Stated**

1. Process Flow Diagram: (Required for all permit applications, except Title V air operation permit revision applications if this information was submitted to the department within the previous five years and would not be altered as a result of the revision being sought) <input checked="" type="checkbox"/> Attached, Document ID: <u>Appendix B</u> <input type="checkbox"/> Previously Submitted, Date _____
2. Fuel Analysis or Specification: (Required for all permit applications, except Title V air operation permit revision applications if this information was submitted to the department within the previous five years and would not be altered as a result of the revision being sought) <input checked="" type="checkbox"/> Attached, Document ID: <u>See Section 5</u> <input type="checkbox"/> Previously Submitted, Date _____
3. Detailed Description of Control Equipment: (Required for all permit applications, except Title V air operation permit revision applications if this information was submitted to the department within the previous five years and would not be altered as a result of the revision being sought) <input type="checkbox"/> Attached, Document ID: _____ <input checked="" type="checkbox"/> Previously Submitted, Date <u>December 2005</u>
4. Procedures for Startup and Shutdown: (Required for all operation permit applications, except Title V air operation permit revision applications if this information was submitted to the department within the previous five years and would not be altered as a result of the revision being sought) <input checked="" type="checkbox"/> Attached, Document ID: <u>Appendix C</u> <input type="checkbox"/> Previously Submitted, Date _____ <input type="checkbox"/> Not Applicable (construction application)
5. Operation and Maintenance Plan: (Required for all permit applications, except Title V air operation permit revision applications if this information was submitted to the department within the previous five years and would not be altered as a result of the revision being sought) <input checked="" type="checkbox"/> Attached, Document ID: <u>Appendix C</u> <input type="checkbox"/> Previously Submitted, Date _____ <input type="checkbox"/> Not Applicable
6. Compliance Demonstration Reports/Records: <input type="checkbox"/> Attached, Document ID: _____ Test Date(s)/Pollutant(s) Tested: _____ <input checked="" type="checkbox"/> Previously Submitted, Date: _____ Test Date(s)/Pollutant(s) Tested: <u>FY 2010 compliance testing results and 2009 Statement of Compliance are included in Appendix D.</u> <input type="checkbox"/> To be Submitted, Date (if known): _____ Test Date(s)/Pollutant(s) Tested: _____ <input type="checkbox"/> Not Applicable Note: For FESOP applications, all required compliance demonstration records/reports must be submitted at the time of application. For Title V air operation permit applications, all required compliance demonstration reports/records must be submitted at the time of application, or a compliance plan must be submitted at the time of application.
7. Other Information Required by Rule or Statute: <input type="checkbox"/> Attached, Document ID: _____ <input checked="" type="checkbox"/> Not Applicable

**EMISSIONS UNIT INFORMATION**

Section [7] of [8]

**I. EMISSIONS UNIT ADDITIONAL INFORMATION (CONTINUED)**

**Additional Requirements for Air Construction Permit Applications**

1. Control Technology Review and Analysis (Rules 62-212.400(10) and 62-212.500(7), F.A.C.; 40 CFR 63.43(d) and (e)): <input type="checkbox"/> Attached, Document ID: _____ <input checked="" type="checkbox"/> Not Applicable
2. Good Engineering Practice Stack Height Analysis (Rules 62-212.400(4)(d) and 62-212.500(4)(f), F.A.C.): <input type="checkbox"/> Attached, Document ID: _____ <input checked="" type="checkbox"/> Not Applicable
3. Description of Stack Sampling Facilities: (Required for proposed new stack sampling facilities only) <input type="checkbox"/> Attached, Document ID: _____ <input checked="" type="checkbox"/> Not Applicable

**Additional Requirements for Title V Air Operation Permit Applications**

1. Identification of Applicable Requirements: <input checked="" type="checkbox"/> Attached, Document ID: <u>See Section 4</u>
2. Compliance Assurance Monitoring: <input type="checkbox"/> Attached, Document ID: _____ <input checked="" type="checkbox"/> Not Applicable <u>See Section 4</u>
3. Alternative Methods of Operation: <input type="checkbox"/> Attached, Document ID: _____ <input checked="" type="checkbox"/> Not Applicable
4. Alternative Modes of Operation (Emissions Trading): <input type="checkbox"/> Attached, Document ID: _____ <input checked="" type="checkbox"/> Not Applicable

**Additional Requirements Comment**

None
------

# EMISSIONS UNIT INFORMATION

Section [8] of [8]

## A. GENERAL EMISSIONS UNIT INFORMATION

### Title V Air Operation Permit Emissions Unit Classification

1. Regulated or Unregulated Emissions Unit? (Check one, if applying for an initial, revised or renewal Title V air operation permit. Skip this item if applying for an air construction permit or FESOP only.)
- The emissions unit addressed in this Emissions Unit Information Section is a regulated emissions unit.
- The emissions unit addressed in this Emissions Unit Information Section is an unregulated emissions unit.

### Emissions Unit Description and Status

1. Type of Emissions Unit Addressed in this Section: (Check one)
- This Emissions Unit Information Section addresses, as a single emissions unit, a single process or production unit, or activity, which produces one or more air pollutants and which has at least one definable emission point (stack or vent).
- This Emissions Unit Information Section addresses, as a single emissions unit, a group of process or production units and activities which has at least one definable emission point (stack or vent) but may also produce fugitive emissions.
- This Emissions Unit Information Section addresses, as a single emissions unit, one or more process or production units and activities which produce fugitive emissions only.

2. Description of Emissions Unit Addressed in this Section:

Cooling Tower

3. Emissions Unit Identification Number: 107

4. Emissions Unit Status Code: A	5. Commence Construction Date:	6. Initial Startup Date: 1985	7. Emissions Unit Major Group SIC Code: 49
-------------------------------------	--------------------------------	----------------------------------	--

8. Federal Program Applicability: (Check all that apply)

- Acid Rain Unit **Not Applicable**
- CAIR Unit

9. Package Unit:

Manufacturer: Marley Cooling Tower Co. Model Number: 597-58-2

10. Generator Nameplate Rating: MW **Not Applicable**

11. Emissions Unit Comment:

None

**EMISSIONS UNIT INFORMATION**

Section [8] of [8]

**Emissions Unit Control Equipment/Method:** Control \_\_\_ of \_\_\_

1. Control Equipment/Method Description:
2. Control Device or Method Code:

**Emissions Unit Control Equipment/Method:** Control \_\_\_ of \_\_\_

1. Control Equipment/Method Description:
2. Control Device or Method Code:

**Emissions Unit Control Equipment/Method:** Control \_\_\_ of \_\_\_

1. Control Equipment/Method Description:
2. Control Device or Method Code:

**Not Applicable**

**Emissions Unit Control Equipment/Method:** Control \_\_\_ of \_\_\_

1. Control Equipment/Method Description:
2. Control Device or Method Code:

**EMISSIONS UNIT INFORMATION**

**Section [8] of [8]**

**I. EMISSIONS UNIT ADDITIONAL INFORMATION**

**Additional Requirements for All Applications, Except as Otherwise Stated**

<p>1. Process Flow Diagram: (Required for all permit applications, except Title V air operation permit revision applications if this information was submitted to the department within the previous five years and would not be altered as a result of the revision being sought)</p> <p><input checked="" type="checkbox"/> Attached, Document ID: <u>Appendix B</u> <input type="checkbox"/> Previously Submitted, Date _____</p>
<p>2. Fuel Analysis or Specification: (Required for all permit applications, except Title V air operation permit revision applications if this information was submitted to the department within the previous five years and would not be altered as a result of the revision being sought)</p> <p><input checked="" type="checkbox"/> Attached, Document ID: <u>See Section 5</u> <input type="checkbox"/> Previously Submitted, Date _____</p>
<p>3. Detailed Description of Control Equipment: (Required for all permit applications, except Title V air operation permit revision applications if this information was submitted to the department within the previous five years and would not be altered as a result of the revision being sought)</p> <p><input type="checkbox"/> Attached, Document ID: _____ <input checked="" type="checkbox"/> Previously Submitted, Date <u>December 2005</u></p>
<p>4. Procedures for Startup and Shutdown: (Required for all operation permit applications, except Title V air operation permit revision applications if this information was submitted to the department within the previous five years and would not be altered as a result of the revision being sought)</p> <p><input checked="" type="checkbox"/> Attached, Document ID: <u>Appendix C</u> <input type="checkbox"/> Previously Submitted, Date _____</p> <p><input type="checkbox"/> Not Applicable (construction application)</p>
<p>5. Operation and Maintenance Plan: (Required for all permit applications, except Title V air operation permit revision applications if this information was submitted to the department within the previous five years and would not be altered as a result of the revision being sought)</p> <p><input checked="" type="checkbox"/> Attached, Document ID: <u>Appendix C</u> <input type="checkbox"/> Previously Submitted, Date _____</p> <p><input type="checkbox"/> Not Applicable</p>
<p>6. Compliance Demonstration Reports/Records:</p> <p><input type="checkbox"/> Attached, Document ID: _____</p> <p>Test Date(s)/Pollutant(s) Tested: _____</p> <p><input type="checkbox"/> Previously Submitted, Date: _____</p> <p>Test Date(s)/Pollutant(s) Tested: _____</p> <p><input type="checkbox"/> To be Submitted, Date (if known): _____</p> <p>Test Date(s)/Pollutant(s) Tested: _____</p> <p><input checked="" type="checkbox"/> Not Applicable</p> <p>Note: For FESOP applications, all required compliance demonstration records/reports must be submitted at the time of application. For Title V air operation permit applications, all required compliance demonstration reports/records must be submitted at the time of application, or a compliance plan must be submitted at the time of application.</p>
<p>7. Other Information Required by Rule or Statute:</p> <p><input type="checkbox"/> Attached, Document ID: _____ <input checked="" type="checkbox"/> Not Applicable</p>

**EMISSIONS UNIT INFORMATION**

Section [8] of [8]

**I. EMISSIONS UNIT ADDITIONAL INFORMATION (CONTINUED)**

**Additional Requirements for Air Construction Permit Applications**

1. Control Technology Review and Analysis (Rules 62-212.400(10) and 62-212.500(7), F.A.C.; 40 CFR 63.43(d) and (e)): <input type="checkbox"/> Attached, Document ID: _____ <input checked="" type="checkbox"/> Not Applicable
2. Good Engineering Practice Stack Height Analysis (Rules 62-212.400(4)(d) and 62-212.500(4)(f), F.A.C.): <input type="checkbox"/> Attached, Document ID: _____ <input checked="" type="checkbox"/> Not Applicable
3. Description of Stack Sampling Facilities: (Required for proposed new stack sampling facilities only) <input type="checkbox"/> Attached, Document ID: _____ <input checked="" type="checkbox"/> Not Applicable

**Additional Requirements for Title V Air Operation Permit Applications**

1. Identification of Applicable Requirements: <input checked="" type="checkbox"/> Attached, Document ID: <u>See Section 4</u>
2. Compliance Assurance Monitoring: <input type="checkbox"/> Attached, Document ID: _____ <input checked="" type="checkbox"/> Not Applicable <u>See Section 4</u>
3. Alternative Methods of Operation: <input type="checkbox"/> Attached, Document ID: _____ <input checked="" type="checkbox"/> Not Applicable
4. Alternative Modes of Operation (Emissions Trading): <input type="checkbox"/> Attached, Document ID: _____ <input checked="" type="checkbox"/> Not Applicable

**Additional Requirements Comment**

None
------

## **3. Facility Additional Information - Additional Requirements for All Applications**

---

### **3.1. Facility Plot Plan**

Refer to Appendix A for the Facility Plot Plan.

### **3.2. Process Flow Diagrams**

Refer to Appendix B for Process Flow Diagrams.

### **3.3. Precautions to Prevent Emissions of Uncontrolled Particulate Matter**

Reasonable precautions used at the McKay Bay Refuse-To-Energy Facility to prevent emissions of uncontrolled particulate matter include the following:

- Roads, parking areas, and yards are paved. A street sweeper equipped with a vacuum system is used to remove particulate matter from roads and other paved areas.
- The tipping floor is located in an enclosed building. Airflow to the boilers provides a negative draft in the tipping building, which minimizes emissions of particulate matter. Floors are washed as required by the Facility's solid waste permit.
- Unpaved areas of the Facility are maintained and either sodded or landscaped.
- Boiler ash and grate siftings are quenched and wetted. Ash conveyors and transfer points are enclosed and maintained to minimize fugitive emissions. Fly ash is wetted in a pug mill ash conditioning system and then blended with the wet boiler ash and grate siftings. The wetted combined ash is processed for recyclable ferrous and non-ferrous metals and stored in a building prior to loading in a truck for disposal. The scalper building and ash management building are equipped with wet scrubbers to control fugitive emissions. Floors are washed as required by the Facility's solid waste permit. The ash hauling trucks are equipped with tarps.



## 4. Facility Additional Information - Additional Requirements for Title V Air Operations Permit Applications

### 4.1. List of Insignificant Activities

The process or production units or other pollutant-emitting activities listed below are located at the Facility and are, by virtue of size or operating rate, eligible for treatment as insignificant emission units in accordance with the criteria of Rule 62-213.430(6)(b), F.A.C., and are requested to be treated as such pursuant to Rule 62-213.420(3), F.A.C. Descriptions and emissions estimates (as necessary) for these insignificant activities/sources are included on the pages that follow.

Activity/Source	Comments
Paint Usage (less than 6 gal/day)	Meets criteria of Rule 62-213.430(6)(b)
Boiler Water Treatment	Listed as trivial source in USEPA White Paper No. 1 (1995)
Cooling Tower Water Treatment	Meets criteria of Rule 62-213.430(6)(b)
Solvent Degreaser	Meets criteria of Rule 62-213.430(6)(b)
Urea Storage Tank	Meets criteria of Rule 62-213.430(6)(b)
Caustic Soda Tank	Meets criteria of Rule 62-213.430(6)(b)
Sulfuric Acid Tank	Meets criteria of Rule 62-213.430(6)(b)
500 Gallon Diesel Fuel Above Ground Storage Tank	Meets criteria of Rule 62-210.300(3)(a)(19)
Vehicular Traffic & Mobile on-site Equipment	Listed as trivial source in USEPA White Paper No. 1 (1995)
Refuse Pit	Meets criteria of Rule 62-213.430(6)(b)
Portable Air Compressors	Listed as trivial source in USEPA White Paper No. 1 (1995)
Portable Welding Machines	Categorically exempt under Rule 62-210.300(3)(a)(13)
Sandblasting Equipment	Meets criteria of Rule 62-213.430(6)(b)
250 Gallon Gasoline Above Ground Storage Tank	Meets criteria of Rule 62-210.300(3)(a)(19)



#### **4.1.1. Activity Descriptions and Emission Estimate Calculations**

##### **4.1.1.1. Paint Usage (less than 6.0 gallons per day)**

Paint usage of less than six (6) gallons per day associated with plant maintenance and upkeep activities meets the criteria of Rule 62-213.430(6)(b), F.A.C. and should be considered insignificant.

##### **4.1.1.2. Boiler Water Treatment**

Chemicals used in boiler feedwater operations are listed as trivial in the White Paper for Streamlined Development of Part 70 Permit Applications (EPA, 1995) and should be considered insignificant.

##### **4.1.1.3. Cooling Tower Water Treatment**

The emissions activity associated with the cooling tower water treatment meets the criteria of Rule 62-213.430(6)(b), F.A.C. and should be considered insignificant.

##### **4.1.1.4. Solvent Degreaser**

The facility has a cold cleaner unit in the maintenance area. The degreasing unit satisfies the requirements of Rules 62-210.300(3)(a)(23), F.A.C. and 62-213.430(6)(b), F.A.C. and should be considered insignificant.

##### **4.1.1.5. Urea Storage Tank**

The facility has one 6,000-gallon urea tank for the NOx control system. The tank satisfies the requirements of Rule 62-213.430(6)(b), F.A.C. and should be considered insignificant.

##### **4.1.1.6. Caustic Soda Tank**

The emissions activity associated with this tank meets the criteria of Rule 62-213.430(6)(b), F.A.C. and should be considered insignificant.

##### **4.1.1.7. Sulfuric Acid Tank**

The facility has one 5,000-gallon sulfuric acid tank on site for water treatment operations. The tank satisfies the requirements of Rule 62-213.430(6)(b), F.A.C. and should be considered insignificant.

##### **4.1.1.8. Diesel Fuel Above Ground Storage Tank**

The Facility has one 500-gallon diesel fuel storage tank for refueling mobile on-site equipment and vehicles. The tank is exempt under Rule 62-210.300(3)(a)(19), F.A.C. and should be considered insignificant.

**4.1.1.9. Vehicular Traffic and Mobile On-Site Equipment**

Combustion emissions from propulsion of mobile sources are listed as trivial in the White Paper for Streamlined Development of Part 70 Permit Applications (EPA, 1995) and should be considered insignificant.

**4.1.1.10. Refuse Pit**

Refuse pit emissions satisfy the requirements of Rule 62-213.430(6)(b), F.A.C. and should be considered insignificant.

**4.1.1.11. Portable Air Compressors**

Air compressors and pneumatically operated equipment are listed as trivial in the White Paper for Streamlined Development of Part 70 Permit Applications (EPA, 1995) and should be considered insignificant.

**4.1.1.12. Portable Welding Machines**

Brazing, soldering or welding equipment is exempt under Rule 62-210.300(3)(a)(13), F.A.C. and should be considered insignificant.

**4.1.1.13. Sandblasting Equipment**

Sandblasting equipment satisfies the requirements of Rule 62-213.430(6)(b), F.A.C. and should be considered insignificant.

**4.1.1.14. Gasoline Above Ground Storage Tank**

The Facility has one 250-gallon diesel fuel storage tank for refueling mobile on-site equipment and vehicles. The tank is exempt under Rule 62-210.300(3)(a)(19), F.A.C. and should be considered insignificant.

## 4.2. List of Applicable Air Quality Regulations

### 4.2.1. Federal Regulations

- 40 CFR 50 – National Primary and Secondary Ambient Air Quality Standards
- 40 CFR 52 (All terms and conditions of Florida permit PSD-FL-086(A))
- 40 CFR 60, Subparts A, Cb
- 40 CFR 61 - National Emissions Standards for Hazardous Air Pollutants (NESHAP)
- 40 CFR 64 - Compliance Assurance Monitoring Rule
- 40 CFR 82 – Stratospheric Ozone Protection

### 4.2.2. Florida Administrative Code (F. A. C.)

- All terms and conditions of Florida Permit PSD-FL-086(B)
- 62-4 – Permits
- 62-4.030
- 62-4.040
- 62-4.050
- 62-4.060
- 62-4.070
- 62-4.080
- 62-4.090
- 62-4.100
- 62-4.120
- 62-4.130
- 62-4.160
- 62-4.210
- 62-204.800(9)(b) – Emissions Guidelines and Compliance Times for Municipal Waste Combustors incorporated by reference
- 62-210 – Stationary Sources - General Requirements
- 62-210.200 – Definitions
- 62-210.300 – Permits Required
- 62-210.300(3) – Exemptions
- 62-210.300(3)(a)13 – Exemption for Brazing, Soldering, or Welding Equipment

- 62-210.300(3)(a)15 – Fire & Safety Equipment
- 62-210.300(3)(a)35 – Exemption for One or More Emergency Generators located within a Single Facility
- 62-210.300(3)(a)36 – Exemption for General Purpose Internal Combustion Engines and Other Reciprocating Internal Combustion Devices
- 62-210.300(5) – Notification of Startup
- 62-210.350 – Public Notice and Comment
- 62-210.360 – Administrative Permit Corrections and Amendments
- 62-210.370(3) – Annual Operating Report
- 62-210.650 – Circumvention
- 62-210.700 – Excess Emissions
- 62-210.900 – Forms and Instructions
- 62-212.400 – Stationary Sources - Preconstruction Review, Prevention of Significant Deterioration (PSD)
- 62-213 – Operation Permits for Major Sources of Air Pollution
- 62-296 – Stationary Sources - Emissions Standards
- 62-296.320 – General Pollutant Emission Limiting Standards
- 62-296.416 – Waste-to-Energy Facilities
- 62-296.416(3) – Mercury Emissions Limiting Standards
- 62-297.310(1) – Required Number of Test Runs
- 62-297.310(2) – Operating Rate During Testing
- 62-297.310(3) – Calculation of Emission Rate
- 62-297.310(4) – Applicable Test Procedures
- 62-297.310(5) – Determination of Process Variables
- 62-297.310(6) – Required Stack Sampling Facilities
- 62-297.310(7) – Frequency of Compliance Tests
- 62-297.310(8) – Test Reports
- 62-297.401 – Compliance Test Methods
- 62-297.620 – Exceptions and Approval of Alternate Procedures and Requirements

### 4.3. Compliance Assurance Monitoring Plan

On October 3, 1997, EPA promulgated new rules under 40 CFR Part 64 and revised 40 CFR Parts 70 and 71 to implement Compliance Assurance Monitoring (CAM) for major stationary sources of air pollution that are required to obtain permits under Title V of the Clean Air Act (the "Act"). Subject to certain exemptions, the CAM rule requires owners or operators of such sources to conduct monitoring that satisfies particular criteria provided in the rule to provide a reasonable assurance of compliance with applicable requirements under the Act. The CAM rule applies to all initial Part 70 and 71 permit applications and applications for a significant permit revision submitted after April 20, 1998.

Malcolm Pirnie completed a CAM applicability determination for each unit at the City of Tampa's McKay Bay Refuse to Energy Facility during the 2005 Title V permit renewal. No significant permit revisions are proposed under this application, so no supplemental information under 40 CFR Part 64 is required.

### 4.4. Requested Changes to Title V Air Operating Permit

The following administrative error corrections are requested to the current Title V Air Operating Permit:

Page 1 of Statement of Basis, last paragraph: "*Emissions from the silos are controlled by baghouses*" should be changed to "*Emissions from the silos are controlled by a **baghouse***."

Page 51, Section III, Subsection C: "*Lime from the spray dryer absorbers for each municipal waste combustor is stored in two silos. Emissions from the silos are controlled by a baghouse.*"

The silos share a common vent filter. This information was correctly stated in the Facility's Title V Renewal Application, dated December 27, 2005.

Page 45, III. B. Emissions Unit- 100 Ash Building and Handling System: "*Since the estimated potential uncontrolled PM emissions are below the major source threshold, the CAM rule does not apply to the ash transfer and storage system's baghouse*" should be changed to "*Since the estimated potential uncontrolled PM emissions are below the major source threshold, the CAM rule does not apply to the ash transfer and storage system's **scrubber***." The Ash Management Building and Handling System has always been equipped with two wet scrubbers, as was stated in the Facility's Title V Renewal Application, dated December 27, 2005.

## 5. Emissions Unit Supplemental Information - All Applications

---

### 5.1. Fuel Analysis or Specifications

The primary fuel for the Facility is municipal solid waste (MSW), including the items and materials that fit within the definition of MSW contained in either 40 CFR 60.51b or Section 403.706(5), Florida Statutes. Secondary fuel is natural gas for the auxiliary burners used during boiler startups, shutdowns, and malfunctions.

The following other solid waste may be used as fuel at the Facility:

- a) Confidential, proprietary, or special documents (including but not limited to business records, lottery tickets, event tickets, coupons, and microfilm);
- b) Contraband which is being destroyed at the request of appropriately authorized local, state, or federal government agencies, provided that such material is not an explosive, a propellant, a hazardous waste, or otherwise prohibited at the facility. Contraband includes but is not limited to drugs, narcotics, fruits, vegetables, plants, counterfeit money, and counterfeit consumer goods;
- c) Wood pallets, clean wood, and land clearing debris;
- d) Packaging materials and containers;
- e) Clothing, natural and synthetic fibers, fabric remnants, and similar debris, including but not limited to aprons and gloves; or
- f) Rugs, carpets and floor coverings, but not asbestos-containing materials or polyethylene or polyurethane vinyl floor coverings.

Waste tires may be used as fuel at the facility. However, waste tires received as segregated loads shall not exceed 3%, by weight, of the facility's total fuel. Compliance with this limitation shall be determined by using a rolling 30-day average in accordance with specific condition A.81 of PSD-FL-086(B) listed below.

The following non-MSW material may also be used as fuel at the facility. The total quantity of non-MSW material received as segregated loads shall not exceed 5%, by weight, of the facility's total fuel. Compliance with this limitation shall be determined by using a rolling 30-day average in accordance with specific condition A.81 of PSD-FL-086(B) listed below.

- a) Construction and demolition debris;

- b) Oil spill debris from aquatic, coastal, estuarine or river environments. Such items or materials include but are not limited to rags, wipes, and absorbents.
- c) Items suitable for human, plant, or domesticated animal use, consumption, or application where the item's shelf life has expired or the generator wishes to remove the items from the market. Such items or materials include, but are not limited to off-specification or expired consumer products, pharmaceuticals, medications, halt and personal care products, cosmetics, foodstuffs, nutritional supplements, returned goods, and controlled substances.
- d) Consumer-packaged products intended for human or domesticated animal use or application but not consumption. Such items or materials include but are not limited to carpet cleaners, household or bathroom cleaners, polishes, waxes, and detergents.
- e) Waste materials that:
  - 1) Are generated in the manufacture of items in categories (c) or (d) above, and are functionally or commercially useless (expired, rejected or spent); or
  - 2) Are not yet formed or packaged for commercial distribution. Such items or materials must be substantially similar to other items or materials routinely found in MSW.
- f) Waste materials that contain oil from:
  - 1) The routine cleanup of industrial or commercial establishments and machinery; or
  - 2) Spills of virgin or used petroleum products. Such items or materials include but are not limited to rags, wipes, and absorbents.
- g) Used oil and used oil filters. Used oil containing a PCB concentration equal to or greater than 50 ppm shall not be burned, pursuant to the limitations of 40 CFR 761.20(e).
- h) Waste materials generated by manufacturing, industrial or agricultural activities, provided that these items or materials are substantially similar to items or materials that are routinely found in MSW, subject to prior approval of the Department.

Auxiliary burners for each MWC unit shall be fired only with natural gas. The annual capacity factor for natural gas for each unit shall be limited to 10% or less in accordance with PSD-FL-086(B).

## 5.2. Detailed Description of Control Equipment

A copy of the Facility's Operations and Maintenance Manual including general description of the Facility's control equipment was submitted with the previous Title V Renewal Application in 2005. No changes have been made to the control equipment during the current permit term.



### **5.3. Procedures for Startup and Shutdown**

The Cover Page and Table of Contents of the Plant Operations Plan are provided in Appendix C in lieu of the complete text. The complete text is on file at the Facility and is updated annually as needed. OP-7, Ash Handling System and OP-15, Distributed Control System are the only two procedures in the manual that have been updated since the past Title V Application submittal. OP-7 and OP-15 were updated on June 10, 2009 and April 5, 2010, respectively. Copies of these operating procedures are included in Appendix C.

### **5.4. Operations and Maintenance Plan**

The Cover Page and Table of Contents of the Plant Operations Manual are provided in Appendix C in lieu of the complete text of the "Wheelabrator McKay Bay, Inc. – Plant Operations Manual (Volumes I and II)." The complete manual is on file at the Facility.

### **5.5. Compliance Report and Plan**

A copy of the 2009 Statement of Compliance (SOC) dated January 15, 2010 and a summary of the most recent annual compliance testing are included as Appendix D. Annual compliance testing was performed on October 6 through 9, 2009 by Clean Air Engineering, Inc. The report indicated no instances of non-compliance and the Facility is operating in compliance with applicable requirement. Therefore, a Compliance Plan is not required to be included in this permit application.

### **5.6. Other Information Required By Rule or Statute**

As of the submittal date of this document, no other information related to the emission units addressed in this application was identified as required by applicable air pollution statutes of the State of Florida or rule of the Department of Environmental Protection.



**City of Tampa**  
**McKay Bay Refuse-to-Energy Facility**  
**Title V Permit Renewal Application**

---

## **Appendix A**

# **Facility Plot Plan**

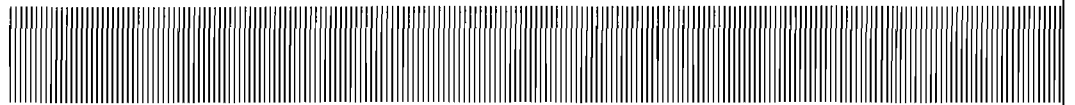

User: T:\MAN Spec\PIRNE STANDARD\T File P City of Tampa\04-3034 McKay Bay Title V Renewal 2005\FINAL DRAFT Title V App\EXH-01 SITE PLAN.DWG Scale: 1/8"=1'-0" Date: 12/16/2005 11:43:53 Layout: Layout1  
 XREFS: IMAGE\$P:City of Tampa\04-3034 McKay Bay Title V Renewal 2005\Working Docs\MISCAN\20050106\_001 TIF P:City of Tampa\04-3034 McKay Bay Title V Renewal 2005\Working Docs\MISCAN\20050105\_002 TIF

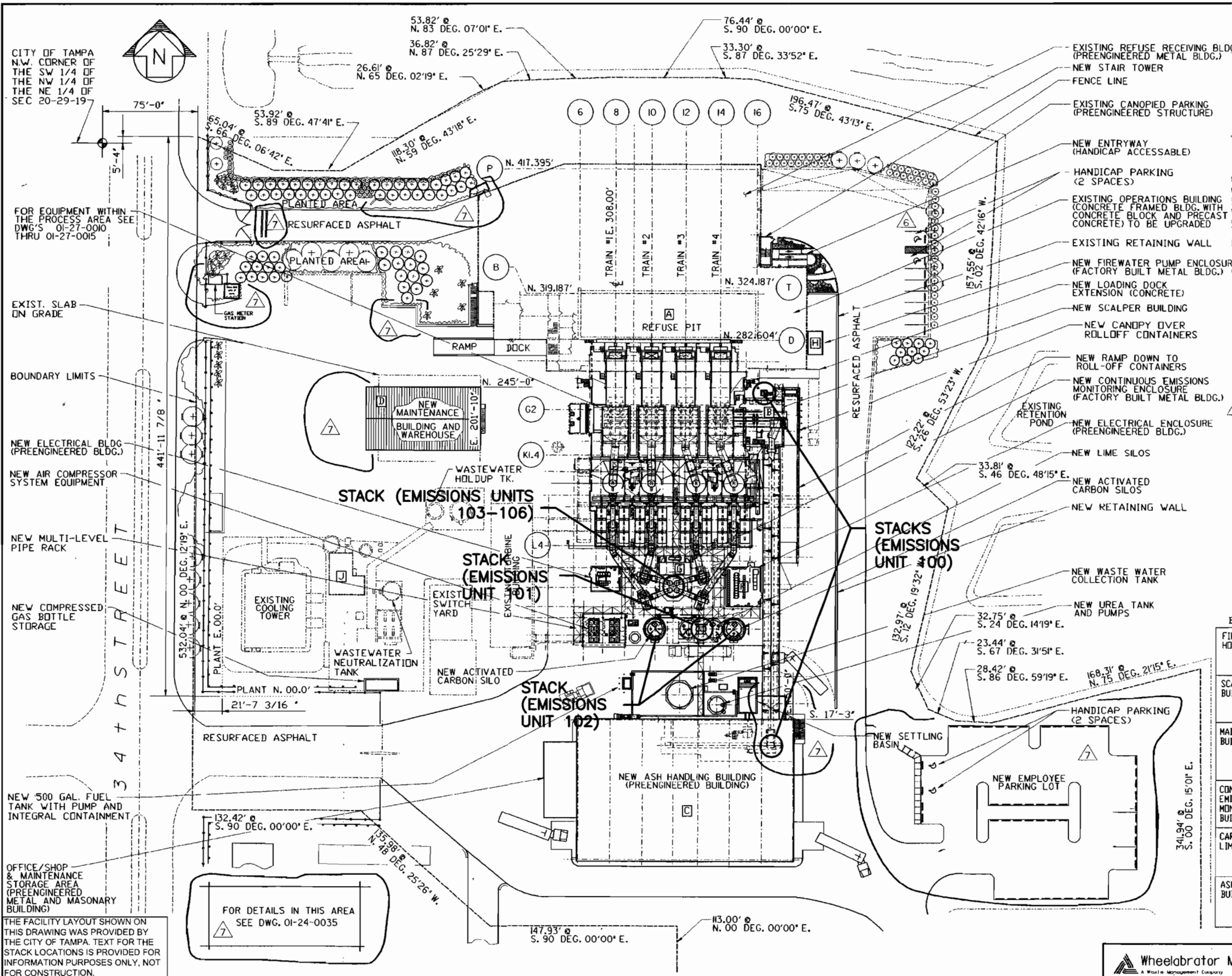

BUILDING AREAS AND HEIGHTS			
BUILDING	CONSTRUCTION TYPE	AREA	BLDG. HEIGHT
A	OPERATIONS/ REFUSE BLDG. (RENOVATION WORK ONLY)		81.25 FT. FOR 40% OF BLDG.
			61.20 FT. FOR 60% OF BLDG.
	FIRST FLOOR	11,691 S.F.	
	SECOND FLOOR	13,059 S.F.	
	THIRD FLOOR	15,160 S.F.	
	TIPPING FLOOR	20,654 S.F.	
	FOURTH FLOOR	10,835 S.F.	
	FIFTH FLOOR	10,835 S.F.	
	TOTAL	82,234 S.F.	
B	SCALPER BLDG.		33 FEET
	FIRST FLOOR	1,400 S.F.	
	SECOND FLOOR	700 S.F.	
	TOTAL	2,100 S.F.	
C	ASH HANDLING BUILDING	19,000 S.F.	48 FEET
D	MAINTENANCE/ WAREHOUSE BUILDING		29 FEET
	FIRST FLOOR	4,500 S.F.	
	SECOND FLOOR	1,235 S.F.	
	TOTAL	5,735 S.F.	
E	WEST ELECTRICAL ENCLOSURE	414 S.F.	13 FEET
F	EAST ELECTRICAL ENCLOSURE	644 S.F.	13 FEET
G	CONTINUOUS EMISSIONS MONITORING ENCLOSURE	260 S.F.	12'-6"
H	FIRE PUMP ENCLOSURE	200 S.F.	13 FEET
J	WATER TREATMENT BUILDING	710 S.F.	16.5 FEET

UTILITY SERVICES LIST		
BUILDING	SERVICES	REMARKS
FIRE PUMP HOUSE	SANITARY - NONE CITY WATER - SEE DWG. 01-28-0002 ELECTRICAL - ABOVEGROUND SYSTEM, ENTERING NEAR WEST SIDE OF BUILDING	PACKAGED PREFAB BLDG PUMP SECTION IS TIED TO CITY WATER SUPPLY
SCALPER BUILDING	SANITARY - NONE CITY WATER - ABOVEGROUND SYSTEM ELECTRICAL - ABOVEGROUND SYSTEM, ENTERING NEAR NORTH-WEST CORNER OF BLDG.	POTABLE WATER IS USED IN PROCESS
MAINTENANCE BUILDING	SANITARY - SEE DWG. 01-28-0001 CITY WATER - SEE DWG. 01-28-0002 AND DWG. 01-28-0003 ELECTRICAL - UNDERGROUND SYSTEM, ENTERING ON SOUTH SIDE OF BLDG.	
CONTINUOUS EMISSIONS MONITORING BUILDING	SANITARY - NONE CITY WATER - NONE ELECTRICAL - UNDERGROUND SYSTEM, TERMINAL BOX ON EAST SIDE OF BLDG.	PACKAGED PREFABRICATED BUILDING
CARBON AND LIME SILOS	SANITARY - NONE CITY WATER - ABOVEGROUND SYSTEM ELECTRICAL - ABOVEGROUND SYSTEM, ENTERING NORTH SIDE OF SILO AREA	POTABLE WATER IS USED IN PROCESS
ASH HANDLING BUILDING	SANITARY - SEE DWG. 01-28-0001 CITY WATER - SEE DWG. 01-28-0002 ELECTRICAL - ABOVEGROUND SYSTEM, ENTERING NEAR NORTH-EAST CORNER OF BLDG.	



NO.	BY	DATE	REVISIONS	REMARKS

**CITY OF TAMPA**  
**MCKAY BAY REFUSE-TO-ENERGY FACILITY**  
**TITLE V RENEWAL APPLICATION**

**Wheelerlabrator McKay Bay Inc.**  
 A Waste Management Company

**RELEASED FOR DESIGN**  
 By STEVE KRANZ Date 09-17-99

**MCKAY BAY REFUSE-TO-ENERGY FACILITY**  
**SITE PLAN**

COPYRIGHT © 2005  
 MALCOLM PIRNIE, INC.  
 DATE DECEMBER 2005  
 SHEET 1 OF 1  
 CAD REF. NO. \_\_\_\_\_

SCALE: 1" = 40'-0"



**City of Tampa**  
**McKay Bay Refuse-to-Energy Facility**  
**Title V Permit Renewal Application**

---

## **Appendix B**

# **Process Flow Diagrams**

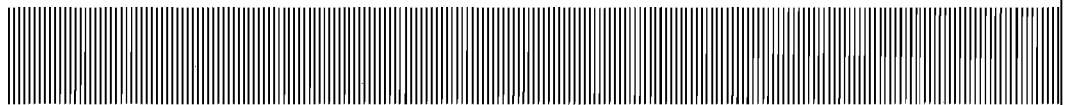

04-21-3-002

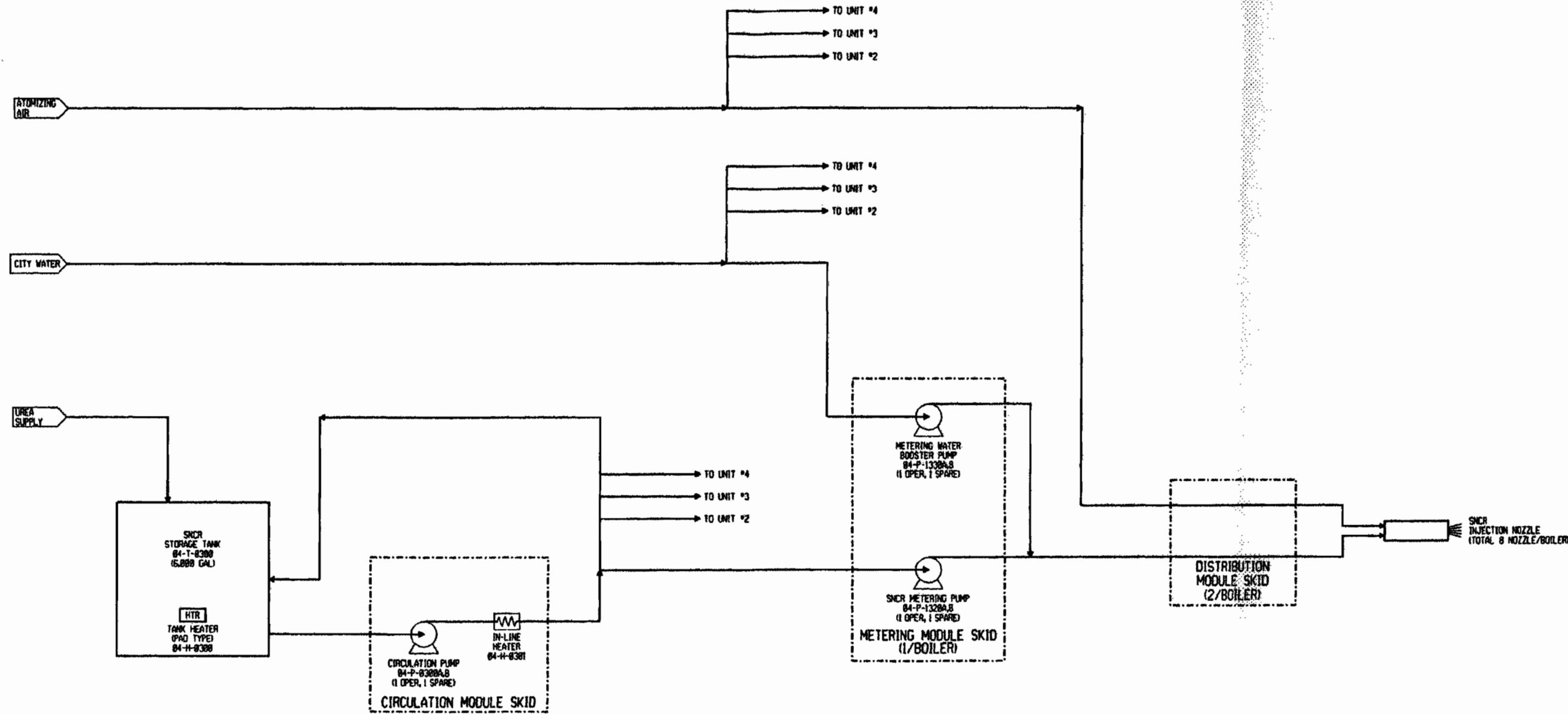

This print and all information thereon is the property of Wheelabrator A.P.C. It is confidential and proprietary and must not be used, made public, or copied unless authorized in writing by Wheelabrator A.P.C. It is transmitted to you with the explicit understanding that it is subject to return upon request.

NOTE: FABRICATION, MANUFACTURING, OR DETAILING MAY PROCEED ONLY WHEN DRAWING IS ISSUED OR AUTHORIZED FOR SUCH PURPOSES.

NO.	REVISION	DATE	NO.	REVISION	DATE	NO.	REVISION	DATE	NO.	REVISION	DATE	NO.	REVISION	DATE	NO.	REVISION	DATE
8	REVISED AS NOTED	8-16-99															
7	ISSUED FOR CONSTRUCTION	1-29-99															

		<b>RECORD DRAWING</b>	
CITY OF TAMPA MCKAY BAY REFUSE TO ENERGY FACILITY RETROFIT PROJECT		WHEELABRATOR AIR POLLUTION CONTROL CONTRACT 3834	
SNCR PROCESS FLOW DIAGRAM		Wheelabrator Air Pollution Control & Waste Management Company	
04-21-3-002		REV. NO. 0	

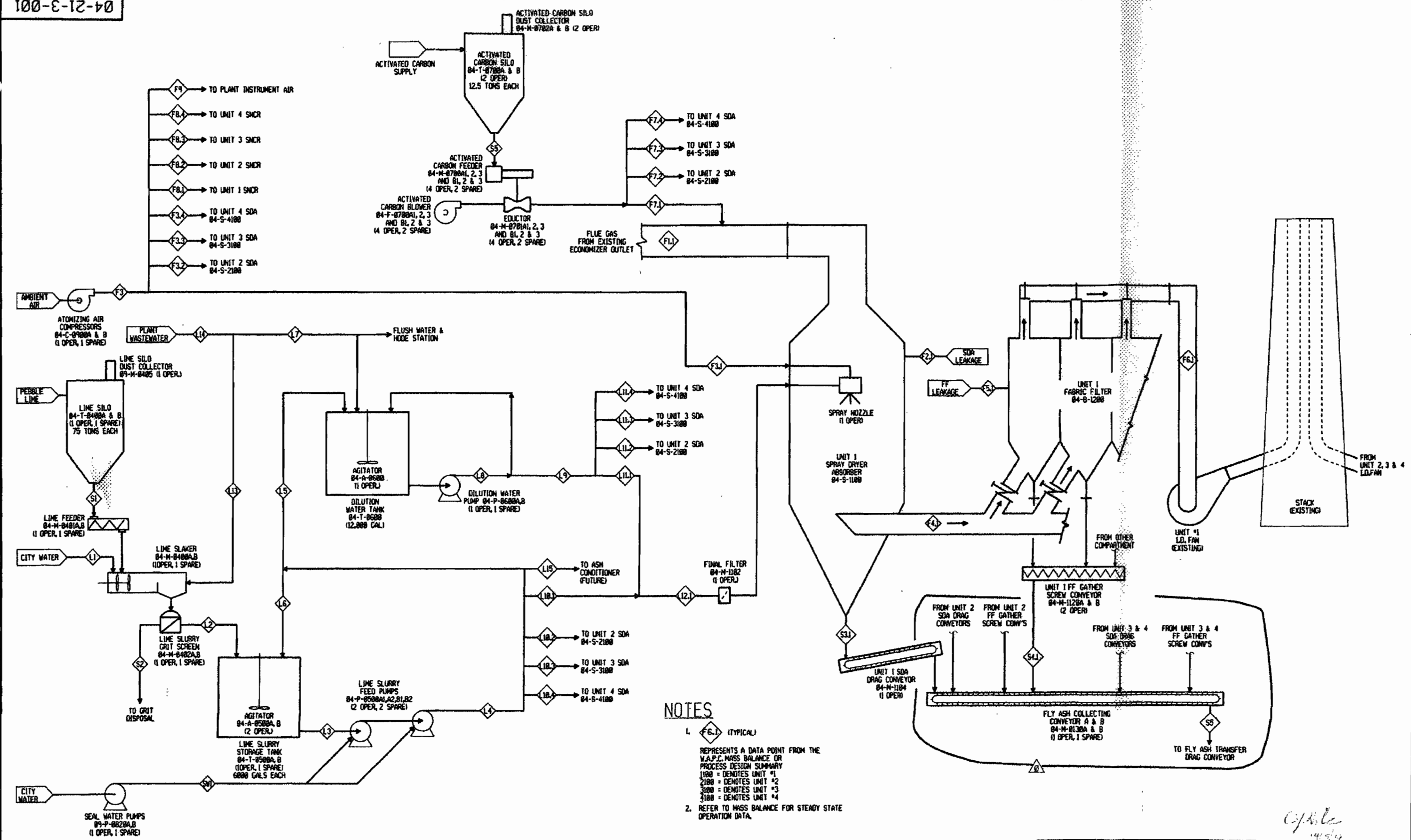

**NOTES**

1. (F.S.) (TYPICAL)  
 REPRESENTS A DATA POINT FROM THE  
 W.A.P.C. MASS BALANCE OR  
 PROCESS DESIGN SUMMARY  
 1100 = DENOTES UNIT #1  
 2100 = DENOTES UNIT #2  
 3100 = DENOTES UNIT #3  
 4100 = DENOTES UNIT #4

2. REFER TO MASS BALANCE FOR STEADY STATE  
 OPERATION DATA.

This print and all information thereon is the property of Wheelabrator A.P.C. It is confidential and proprietary and must not be used, made public, or copied unless authorized in writing by Wheelabrator A.P.C. It is transmitted to you with the explicit understanding that it is subject to return upon request.

NOTE  
 FABRICATION, MANUFACTURING, OR DETAILING MAY PROCEED ONLY  
 WHEN DRAWING IS ISSUED OR AUTHORIZED FOR SUCH PURPOSES.

NO.	REVISION	DATE	NO.	REVISION	DATE	NO.	DATE	TO	FOR	REV.	DATE	TO	FOR	REV.	DATE	TO	FOR	CHKD. BY	JED	DATE
8	REVISED AS NOTED	8-16-99																		5-19-99
9	REVISED AS NOTED	11-29-99																		12-28-99
																				12-20-99

**Wheelabrator McKay Bay Inc.**

**RECORD DRAWING**

WHEELABRATOR AIR POLLUTION CONTROL CONTRACT 3834

CITY OF TAMPA  
 MCKAY BAY REFUSE TO ENERGY FACILITY  
 RETROFIT PROJECT

**Wheelabrator Air Pollution Control**  
 A Waste Management Company

PROCESS FLOW DIAGRAM

RECEIVED 04-21-3-001

REV. NO. 0

DATE:

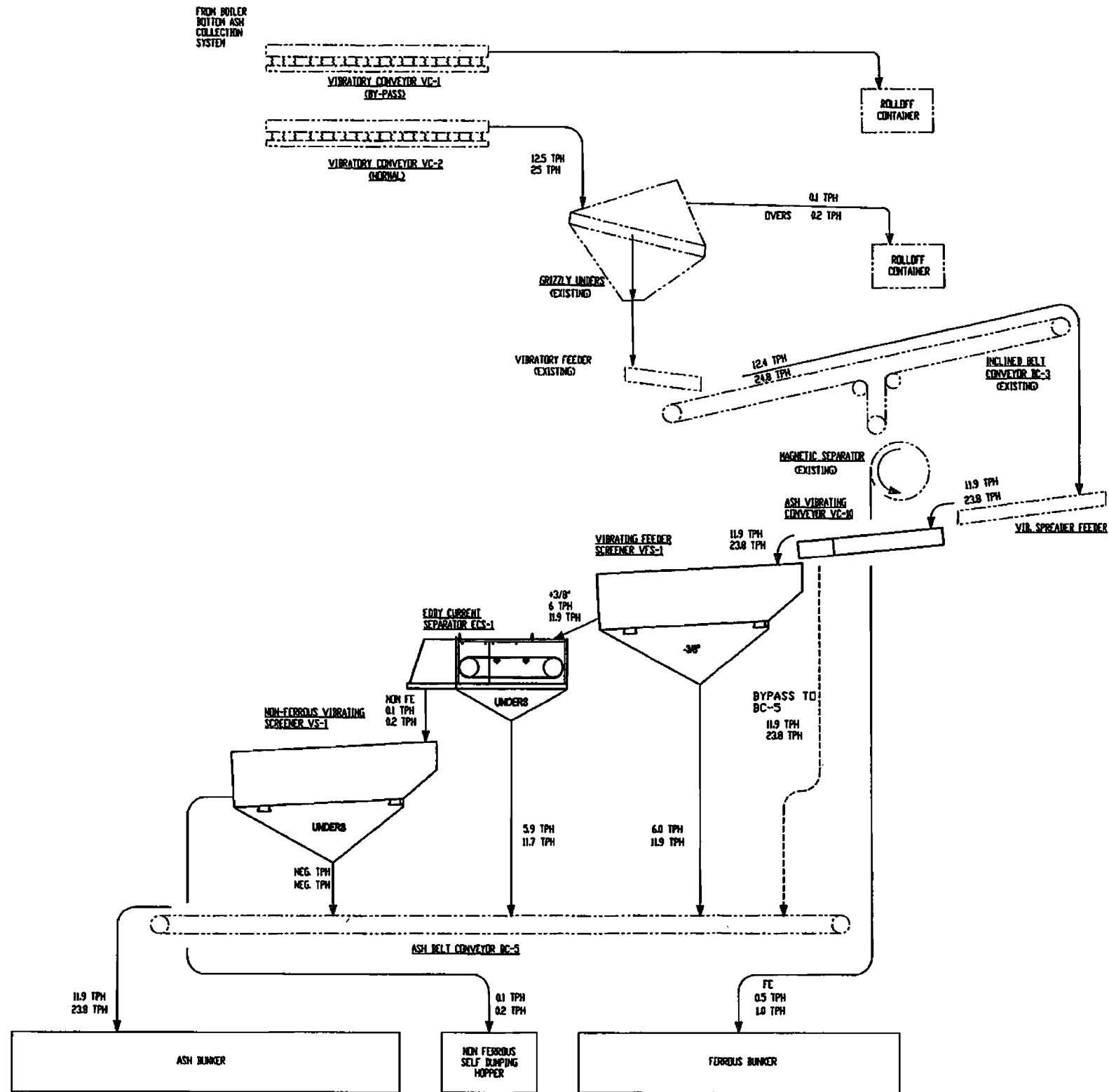

- NOTES:**
1. TPH (TONS PER HOUR)
  2. FLOW RATES SHOWN ABOVE LINE REPRESENT NORMAL FLOW. FLOW RATES SHOWN BELOW LINE REPRESENT DESIGN FLOW.

*David L. Nederveld*  
6/2/09

CASE ENGINEERING, INC  
5825 IMPERIAL PARKWAY, SUITE 228  
MULBERRY, FLORIDA 33860

PROFESSIONAL ENGINEER **DAVID L. NEDERVELD**  
PROFESSIONAL LICENSE NUMBER **18820**



**WHEELABRATOR McKay Bay**  
TAMPA, FLORIDA  
NON-FERROUS METALS RECOVERY  
PROCESS FLOW DIAGRAM

DRAWN BY	RMS / RMC	02-26-09	DESIGN BY	DLN
CHECKED BY			DWG. SCALE	FULL SIZE
APPROVED BY			PLOT SCALE	1 = 1
CLIENT APPVL			DRAWING NO.	3533-F-001
REV.	DATE	ISSUE	REV.	DATE

NO.	REVISION	BY	DATE	ISSUE	DRAWING HISTORY	REV.	DATE
C	ISSUE FOR BID/PERMIT		P2	JUNE 1, 2009			
B	ISSUE FOR COMMENT (60% DESIGN REVIEW)		P1	MAY 5, 2009			
A	ISSUE FOR COMMENT (30% DESIGN REVIEW)		P0	MAR 18, 2009			

REFERENCE DRAWINGS

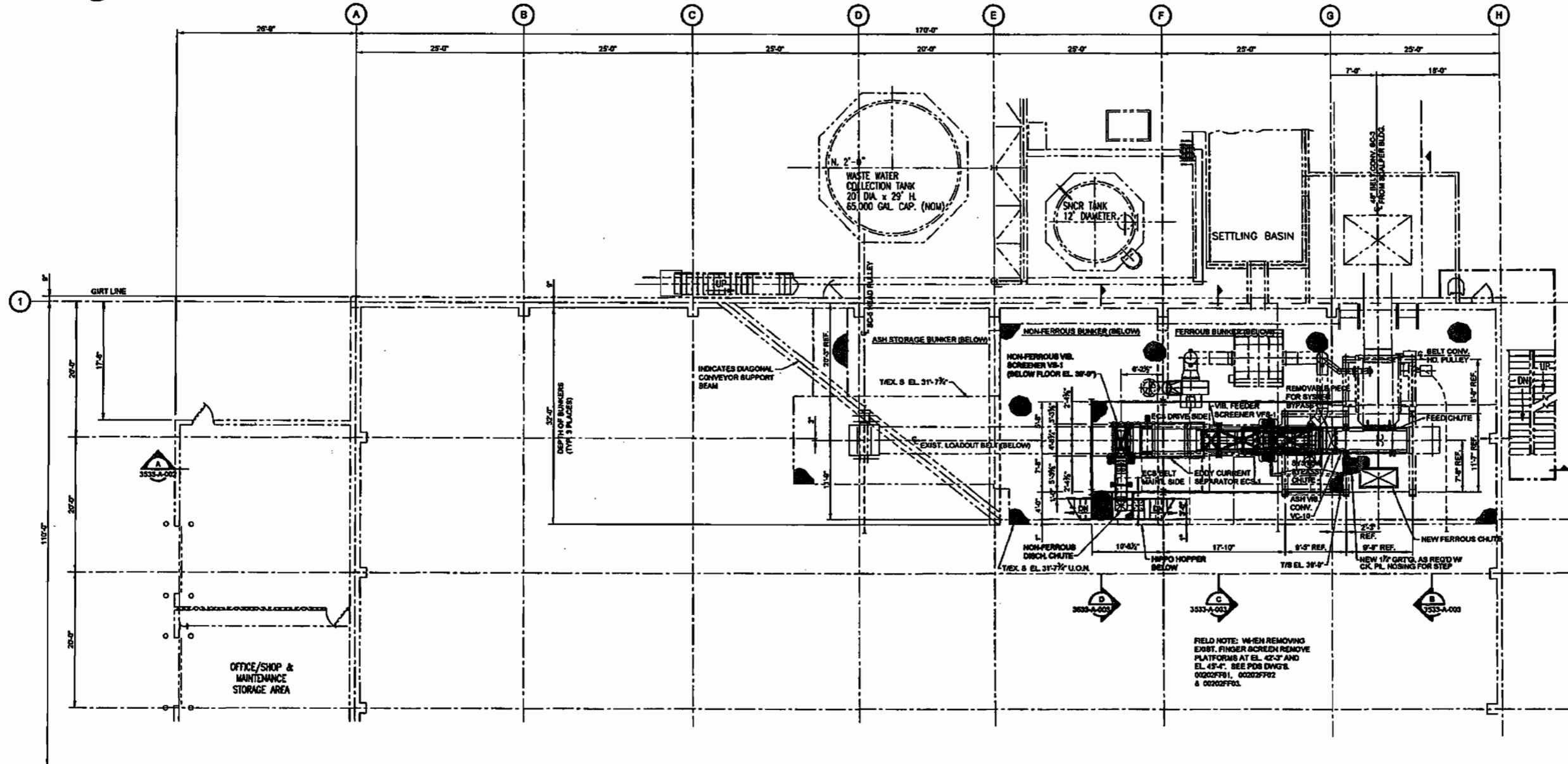

PLAN @ T/S EL. 39'-9"

1/8" = 1'-0"

*D*  
*6/2/09*

CASE ENGINEERING, INC.  
5625 IMPERIAL PARKWAY, SUITE 228  
MULBERRY, FLORIDA 33860

PROFESSIONAL ENGINEER **DAVID L. NEDERVELD**  
PROFESSIONAL LICENSE NUMBER **16820**

 **CASE ENGINEERING**  
MULBERRY, FLORIDA  
CERTIFICATE OF AUTHORIZATION NO. 2270

**WHEELABRATOR McKAY BAY**  
TAMPA, FLORIDA  
NON-FERROUS METALS RECOVERY  
GENERAL ARRANGEMENT - PLAN @ T/S EL. 31'-9"

NO.	REVISION	BY	DATE	ISSUE	DRAWING HISTORY	REV.	DATE
				C	ISSUE FOR BID/PERMIT	P2	JUNE 1, 2009
				B	ISSUE FOR COMMENT (30% DESIGN REVIEW)	P1	MAY 8, 2009
				A	ISSUE FOR COMMENT (30% DESIGN REVIEW)	P0	MAR 16, 2009

DRAWN BY: RNS/RMC 02-18-09  
CHECKED BY: DLN  
APPROVED BY: DLN  
CLIENT APPR: [Signature]

DESIGN SCALE: 1/2" = 1'-0"  
PLOT SCALE: 1" = 6'  
DRAWING NO.: 3533-A-001  
REV. P2

REFERENCE DRAWINGS

NO.	REVISION	BY	DATE	ISSUE	DRAWING HISTORY	REV.	DATE
				C	ISSUE FOR BID/PERMIT	P2	JUNE 1, 2009
				B	ISSUE FOR COMMENT (30% DESIGN REVIEW)	P1	MAY 8, 2009
				A	ISSUE FOR COMMENT (30% DESIGN REVIEW)	P0	MAR 16, 2009



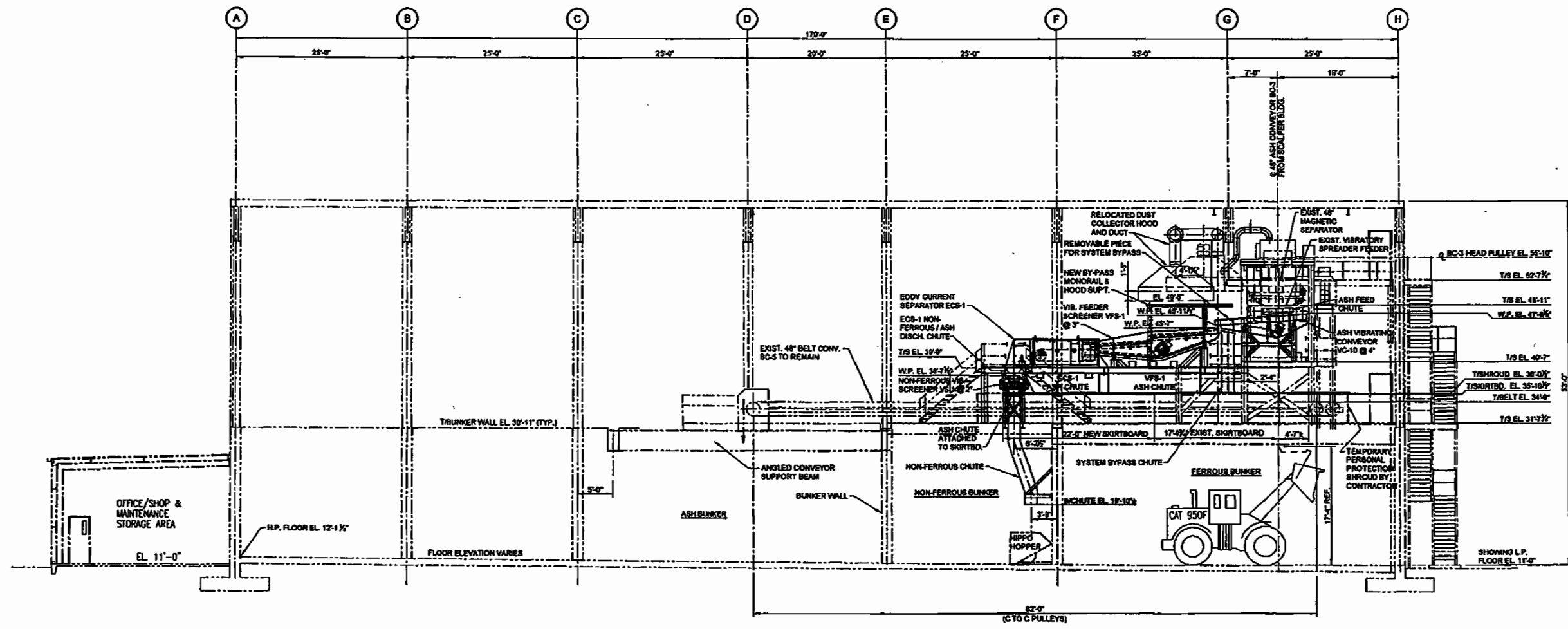

**SECTION A**  
1/2" = 1'-0" 3533-A-001

*D*  
*4/2/09*

CASE ENGINEERING, INC  
6825 IMPERIAL PARKWAY, SUITE 228  
MULBERRY, FLORIDA 33660

PROFESSIONAL ENGINEER **DAVID L. NEDERVELD**  
PROFESSIONAL LICENSE NUMBER **16620**



**WHEELABRATOR MCKAY BAY**  
TAMPA, FLORIDA  
NON-FERROUS METALS RECOVER  
GENERAL ARRANGEMENT - SECTION

DRAWN BY	RMS / RMC	02-19-08	DESIGN BY	DLN
CHECKED BY	DLN		DWG. SCALE	N = 1'-0"
APPROVED BY			PLOT SCALE	1 = 1/8"
CLIENT APPL.			DRAWING NO.	
			REV.	P2

NO.	REVISION	BY	DATE	ISSUE	DRAWING HISTORY	REV.	DATE
	C			ISSUE FOR BID/PERMIT		P2	JUNE 1, 2008
	B			ISSUE FOR COMMENT (80% DESIGN REVIEW)		P1	MAY 5, 2008
	A			ISSUE FOR COMMENT (30% DESIGN REVIEW)		P0	MAR 18, 2008

REFERENCE DRAWINGS

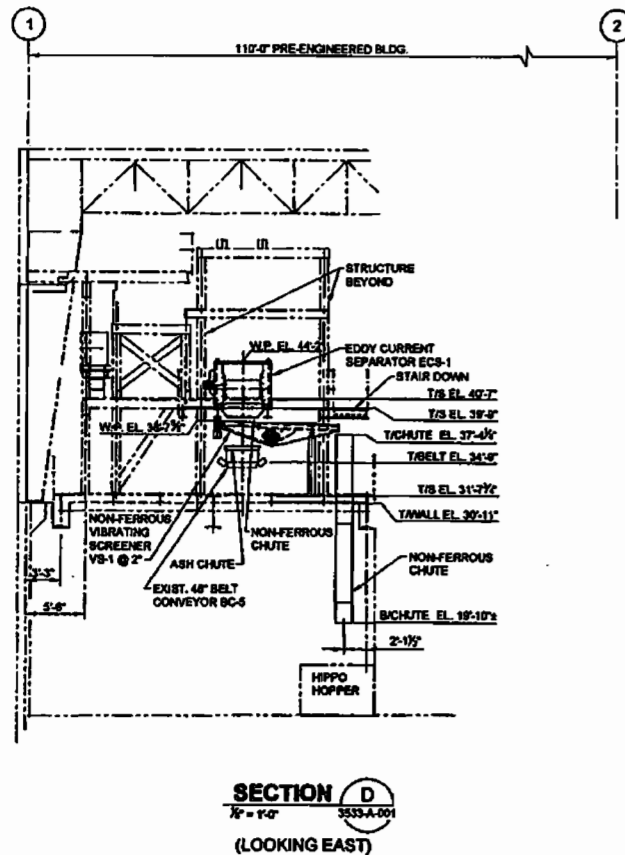
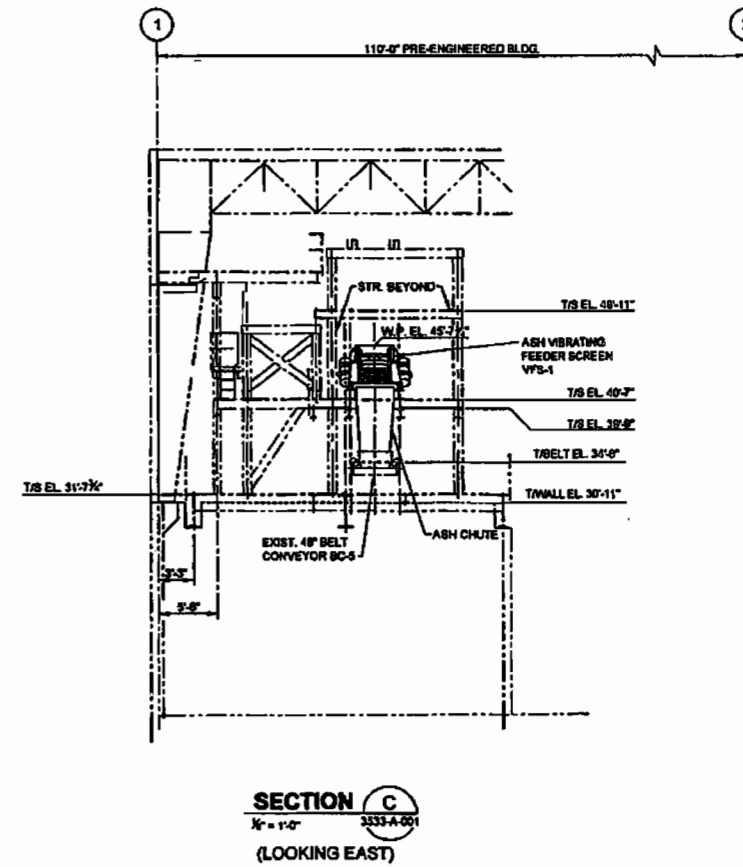
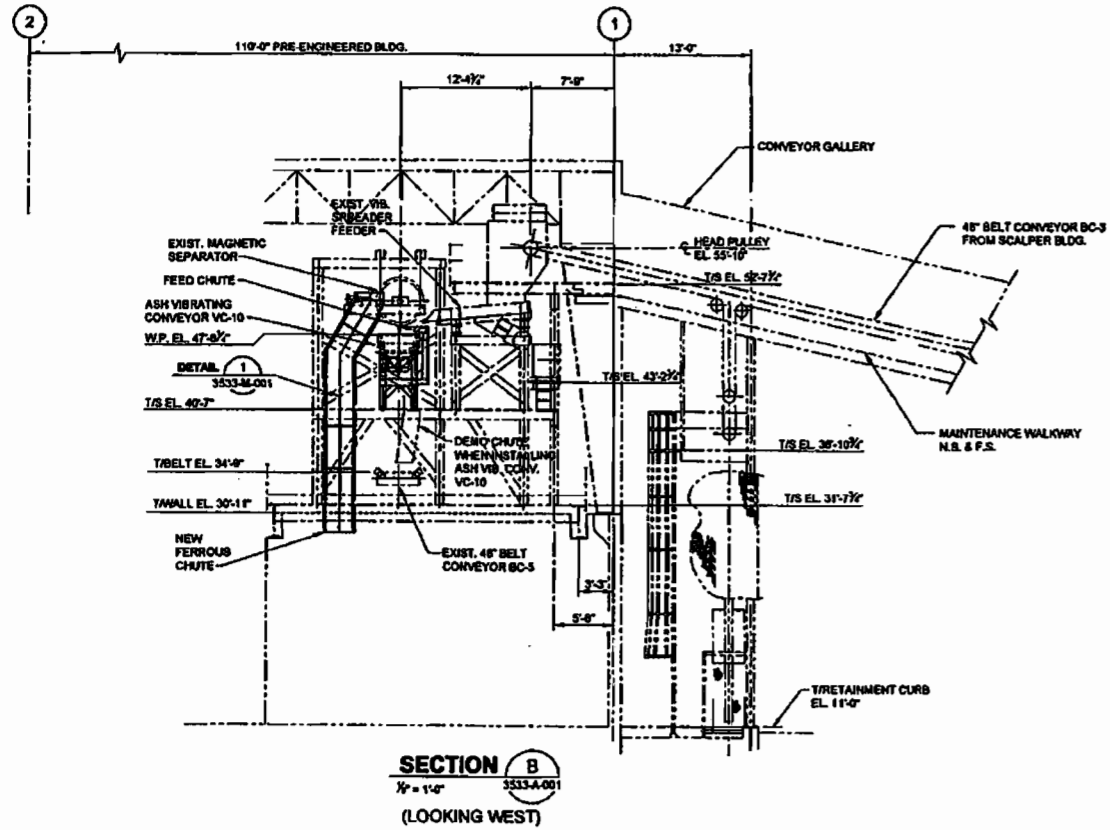

*D L N*  
6/2/09

CASE ENGINEERING, INC  
5825 IMPERIAL PARKWAY, SUITE 228  
MULBERRY, FLORIDA 33880

PROFESSIONAL ENGINEER **DAVID L. NEDERVELD**  
PROFESSIONAL LICENSE NUMBER **16820**

**CASE ENGINEERING**  
MULBERRY, FLORIDA  
CERTIFICATE OF AUTHORIZATION NO. 2270

**WHEELABRATOR McKAY BAY**  
TAMPA, FLORIDA  
NON-FERROUS METALS RECOVERY  
GENERAL ARRANGEMENT / SECTIONS

DRWN BY	RMS/RMC	02-18-09	EGM BY	DLN
CHECKED BY	CLN		DRWG SCALE	1/2" = 1'-0"
APPROVED BY			PLOT SCALE	1" = 30'
DATE	MAR 18, 2009		CLIENT APPR.	
REV.			DRAWING NO.	3533-A-003
			REV.	P2

NO.	REVISION	BY	DATE	ISSUE	DRAWING HISTORY	REV.	DATE
				C	ISSUE FOR BID/PERMIT	P2	JUNE 1, 2009
				B	ISSUE FOR COMMENT (30% DESIGN REVIEW)	P1	MAY 5, 2009
				A	ISSUE FOR COMMENT (30% DESIGN REVIEW)	P0	MAR 18, 2009

REFERENCE DRAWINGS

6.0 APPENDIX

6.1 System Diagrams

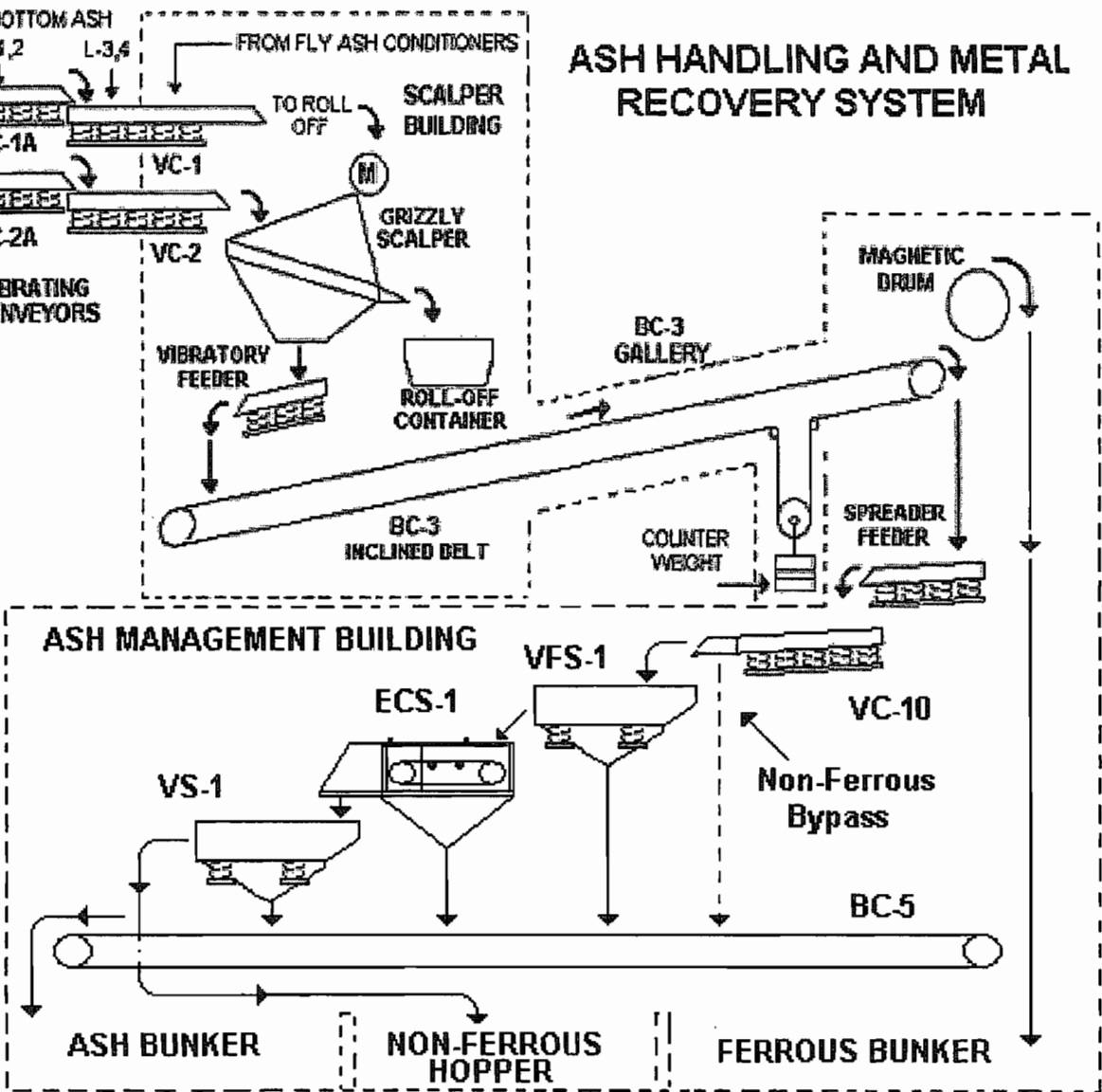



**City of Tampa**  
McKay Bay Refuse-to-Energy Facility  
Title V Permit Renewal Application

---

## **Appendix C**

# **Plant Operations Manual and Operating Procedures OP-7 & OP-15**

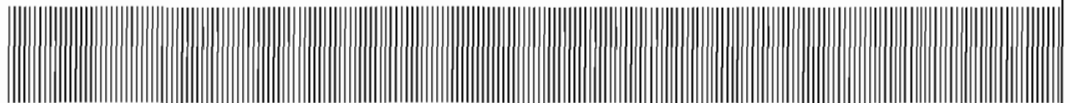

***WHEELABRATOR MCKAY BAY, INC.***

**PLANT OPERATIONS MANUAL**

REV 10  
April 5, 2010

## CONTENTS

### PLANT DESCRIPTION

- OP-1: REFUSE RECEIVING AND HANDLING SYSTEM
- OP-2: BOILER – COMBUSTION SYSTEM
- OP-3: BOILER – STEAM GENERATION SYSTEM
- OP-4: BOILER – AUXILIARY FUEL SYSTEM
- OP-5: AIR POLLUTION CONTROL SYSTEM
- OP-6: CONTINUOUS EMISSIONS MONITORING SYSTEM, CEM PERFORMANCE

### TESTING, RECORD KEEPING AND REPORTING

- OP-7: ASH HANDLING SYSTEM
- OP-8: STEAM DISTRIBUTION SYSTEM
- OP-9: CONDENSATE SYSTEM
- OP-10: BOILER FEEDWATER SYSTEM
- OP-11: TURBINE SYSTEM
- OP-12: TURBINE OIL SYSTEM
- OP-13: GENERATOR AND EXCITER SYSTEM
- OP-14: ELECTRICAL DISTRIBUTION SYSTEM
- OP-15: DISTRIBUTED CONTROL SYSTEM
- OP-16: SERVICE AND CITY WATER SYSTEM
- OP-17: CLOSED COOLING WATER SYSTEM
- OP-18: CIRCULATING WATER SYSTEM
- OP-19: SERVICE AIR SYSTEM
- OP-20: WASTEWATER SYSTEM
- OP-21: WATER TREATMENT SYSTEM
- OP-22: FREEZE PROTECTION
- OP-23: FIRE PROTECTION SYSTEM
- OP-24: THERMAL DENOX SYSTEM

**As Required by Code of Federal Regulations (CFR) 40 volume 6 part 60,  
Section 60.54b page 158. paragraph (e)**

The owner or operator of an affected facility shall develop and update on a yearly basis a site-specific operating manual that shall, at a minimum, address the element so municipal waste combustor unit operation specified in paragraphs (e) (1) through (e) 11 of this section

- (1) A summary of the applicable standards under this subpart (see this page)
- (2) A description of basic combustion theory applicable to a municipal waste combustor unit. (Wheelabrator McKay Bay Operations Manual OP-2 and 3)
- (3) Procedures for receiving, handling, and feeding municipal solid waste. (Wheelabrator McKay Bay Operations Manual OP-1)
- (4) Municipal waste combustor unit startup, shutdown, and malfunction procedures. (Wheelabrator McKay Bay Operations Manual OP-2, 3, 4, 5, 6, 7, 8, 9, 10, 14, 15, 16, 19, 20, & 24)
- (5) Procedures for maintaining proper combustion air supply levels. (Wheelabrator McKay Bay Operations Manual OP-2)
- (6) Procedures for operating the municipal waste combustor unit within the standards established under this subpart. (Wheelabrator McKay Bay Operations Manual OP-2, 3, 4, & 5)
- (7) Procedures for responding to periodic upset of off-specification conditions. (Wheelabrator McKay Bay Operations Manual OP-2—24)
- (8) Procedures for minimizing particulate matter carryover. (Wheelabrator McKay Bay Operations Manual OP-2 and 5)
- (9) Procedures for handling ash. (Wheelabrator McKay Bay Operations Manual OP-7 and 20)
- (10) Procedures for monitoring municipal waste combustor unit emissions. (Wheelabrator McKay Bay Operations Manual OP-5 and 6)
- (11) Reporting and record keeping procedures. (Wheelabrator McKay Bay Operations Manual OP-6 & McKay Bay Standard CEM data validation and record keeping practice and quality assurance plan)

**WHEELABRATOR McKAY BAY INC.**

**OPERATING PROCEDURES**

**OP - 7: ASH HANDLING SYSTEM**



## CONTENTS

1.0 INTRODUCTION.....	4
1.1 Purpose and Scope.....	4
1.2 References .....	5
1.2.1 P & IDs.....	5
1.2.2 Manuals.....	5
1.3 Operational Outline .....	6
2.0 SYSTEM START UP .....	8
2.1 Preoperational Instructions .....	8
2.1.1 Prerequisites .....	8
2.1.2 Precautions and Limitations.....	8
2.1.3 Prestart Checklist.....	9
2.2 System Startup Instructions .....	9
2.2.1 Milestones.....	9
2.2.2 Place the Ash Disposal System & Vibration Conveyor in Service Without Metal Recovery .....	10
2.2.3 Place the Ferrous metal Recovery System in Service (Magnetic Separator) .....	12
2.2.4 Place the Non-Ferrous metal Recovery System in Service (Eddy Current Separator) .....	13
2.2.5 Starting and Operating VC-1 .....	15
2.2.6 Place the Boiler Sifting Drag Chain Conveyors in Service .....	16
2.2.7 Place the Boiler Flyash Screw Conveyors in Service.....	16
2.2.8 Place the Flyash Transport & Conditioning System In Service ...	17
3.0 SYSTEM NORMAL OPERATIONS .....	19
3.1 Normal Operation.....	19
3.2 Switching the Flyash Mixer (A to B) .....	20
3.3 Switching the Flyash Transfer Drag Conveyors .....	20
4.0 SYSTEM SHUTDOWN.....	21

4.1	Removing the Bottom Ash Collecting System from Service .....	21
4.1.1	Temporary Stop to Empty Roll-off Container .....	21
4.1.2	Bottom Ash System Shutdown.....	22
4.2	Removing the Fly Ash transport & Conditioning System from Service.....	24
5.0	ALARM RESPONSES .....	26
5.1	Summary of Alarms .....	26-33
6.0	APPENDIX .....	34
6.1	System Diagrams .....	34-36

Wheelabrator McKay Bay Inc.

## **1.0 INTRODUCTION**

### **1.1 Purpose and Scope**

The purpose of this procedure is to provide plant operations personnel with a standard procedure to start up, operate normally and shut down the Ash Handling System.

The functions of the Ash Handling System are to:

- A. Collect, cool and transfer bottom ash, siftings, and fly ash from the boilers to the disposal system.
- B. Seal the bottoms of the boilers to help maintain proper combustion air and flue gas flow through the boilers.
- C. Collect, condition, and transfer fly ash from the Fabric Filters and SDAs to the disposal system.
- D. Separate large material (mostly metals), from the ash stream.
- E. Recover ferrous metals & non-ferrous from the ash stream for recycling.

The following systems interface with the Ash Handling System:

- A. From the system:
  1. Ash Management Building Storage Area
  2. Ash and Metal Transport Trucks
  3. Wastewater System
- B. To the system:
  1. Service Air System
  2. Wastewater System
  3. Electrical Distribution System
  3. Fire Protection System
  4. Distributed Control System
  5. Boiler—Combustion System
  6. Air Pollution Control System

Wheelabrator McKay Bay Inc.

## **1.2 References**

### **1.2.1 P&IDs**

- A. 01-28-2009-S Waste Water System
- B. 01-28-2012-S Ash Handling System (Fly Ash)
- C. 01-28-2013-S Ash Handling System (Boiler Bottom Ash)
- D. 01-28-2207-S Boiler Fuel and Ash System (Sifting System)
- E. 01-28-2207-S Boiler Ash System
- F. 04-21-3-112-S Air Pollution Area Ash Handling System
- G. 3533-PF-001 Non-Ferrous Metals Recovery System

### **1.2.2 Manuals**

- A. Von Roll – Grate System / Hydraulic Feeder / Combustion Air Fans / Steam Coil Air Heater / Ash Expeller – McKay Bay Refuse to Energy Facility Retrofit Project VOL 1.
- B. Balance of Plant Systems – McKay Bay Refuse to Energy Facility Retrofit Project:
  - 1) Beaumont Birch – Belt Conveyors, Gallery, and Supports
  - 2) Ash Tech – Flyash Conditioning System/Transfer Drag Conveyor
  - 3) General Kinematics – Bottom Ash Vibrating Conveyors, Finger Screen, Vibrator Spreader Feeder
  - 4) OS Walker – Magnetic Separator

Wheelabrator McKay Bay Inc.

### **1.3 Operational Outline**

The Ash Handling System collects Wet Bottom Ash from the bottom Ash Expellers and Grate Sittings Conveyors. Then Dry flyash from the Air Pollution Control Equipment is transported, conditioned and added to the bottom ash residue. The combined Ash Stream is transported to a separate Ash Handling Building for metals separation, storage and truck loading from the plant site. This procedure will discuss startup, operation and shutdown of the Ash Handling System.

The Ash Handling system contains the following equipment:

- A. **ASH MANAGEMENT BUILDING:** Used for storage, and disposal point for the ash & metals from the plant.
  
- B. **SCALPER BUILDING:** Prevents the spreading of dust while combining of the fly ash and bottom ash. It also provides for the separation of large materials from the ash stream
  
- C. **GRIZZLY SCALPER:** Removes large materials from the ash stream greater than 6" to a roll-off container. The vibratory action of the grizzly spreads the material out and directs it toward the grizzly scalping bars. Minus 6" material falls through the grizzly onto the vibratory feeder and BC-3. Removal of large materials prevents overloading of the BC-3 ash incline belt.
  
- D. **VIBRATING CONVEYORS:** Transport the ash from the ash expellers and the sifting conveyors.
  
- E. **FLYASH TRANSPORT CONVEYORS:** Transport flyash from the air pollution control equipment (Fabric Filters and SDAs) to the ash conditioners.
  
- F. **ASH CONDITIONERS:** Used to mix water in to the fly ash stream to prevent dusting as the flyash is deposited with the bottom ash on the vibrating conveyors.
  
- G. **SIFTING DRAG CHAIN CONVEYORS:** Remove grate siftings (riddlings) from under the grate zones and onto the vibrating conveyors

Wheelabrator McKay Bay Inc.

- H. **MAGNETIC SEPERATOR** – Separates ferrous material from the ash stream as it enters the ash management building for recycling.
- I. **EDDY CURRENT SEPARATOR** – Separates non-ferrous metals from the ash stream after ferrous separation for recycling
- J. **FRONT END LOADER** – Loads metal and ash onto trucks for disposal off plant site.

The major components and subsystems that must be placed in service for the Ash Handling System are:

- A. Sifting Hoppers (6 for each boiler).
- B. Sifting Drag Chain Conveyors.
- C. Sifting Screw
- D. Vibratory Conveyors
- E. Grizzly Scalper
- F. Ash Expeller
- G. Economizer Flyash Screw conveyors (2 each Boiler)
- H. Fly Ash Transport Conveyor Systems.
- I. Ash conditioner
- J. Spreader Feeder.
- K. BC-3 Ash Incline Belt
- L. BC-5 Ash Belt
- M. VC-10 Vibrating Conveyor
- N. Vibratory Feeder
- O. Spreader Feeder
- P. Magnetic Separator
- Q. VFS-1 Vibrating Feeder Screener
- R. ECS-1 Eddy Current Separator
- S. VS-1 Non-Ferrous Vibrating screener
- T. Fabric Filter Gather Screw Conveyors
- U. Flyash collecting and transfer drag chain conveyors
- V. SDA Drag Chain Conveyors

Wheelabrator McKay Bay Inc.

## **2.0 SYSTEM START UP**

### **2.1 Preoperational Instructions**

#### **2.1.1 Prerequisites**

- A. The ash expellers and sifting drag chain conveyors for the units to be operated are filled with wastewater.
- B. The ash handling area is ready to receive ash before starting the fly ash or bottom ash systems.
- C. Service Air System in service. (OP-19)
- D. Waste Water System in service (OP-21)
- E. Distributed Control System (DCS) in Service (OP-15)
- F. Electrical Distribution System is in service.(OP-14)
- G. Settling basin sump pumps are in service.
- H. Ash building and scalper building wet scrubber systems in service.
- I. Roll-off container/truck in place in scalper building.
- J. Non-Ferrous bin is in place in middle bunker in Ash Building

#### **2.1.2 Precautions and Limitations**

- A. Operators must stay clear of rotating machinery and moving belts. Plant personnel should never stand or work on a moving belt or conveyor.
- B. Dust masks or breathers, protective clothing, head protection should be worn at all times when working around ash handling areas and equipment.
- C. Plant personnel should never attempt to free the throat or inner ram of an ash expeller when it is operating.
- D. Plant personnel should never walk or slide on any ash-handling chute, even when not in service.
- E. Equipment should never be operated without all the safety devices in place and operational. All warning stickers and labels must remain in plain view to all plant personnel.
- F. Under no circumstances should any piece of equipment be worked on unless it is at a complete standstill, it is cool, and has been locked out.
- G. Water in the ash expellers is extremely hot, all precautions should be taken prior to draining or servicing.

Wheelabrator McKay Bay Inc.

**2.1.3 Prestart Checklist**

- A. All permits are released, tags are removed, and equipment is in a safe condition for operation.
- B. All access doors on the flyash conveyors, ash expellers, surge bins, drag chain conveyors, system hoppers, and auxiliaries are closed.
- C. Waste water System is operational.
- D. Surge bins are empty on the ash conditioners.
- E. All fire protection systems are operational.
- F. Service air is available.
- G. All safety interlocks are operational.
- H. All instrumentation is available.
- I. All rotating equipment guards and safety devices are installed.
- J. Proper system valve line-up has been verified
- K. System equipment power supplies have been activated.
- L. Proper water levels are in the ash expellers and sifting conveyors.

**2.2 System Startup Instructions**

**2.2.1 Milestones**

- A. Place the Ash Disposal System and Vibration Conveyors in Service Without Metal Recovery (Section 2.2.2).
- B. Place the Ferrous Metal Recovery System in Service (Magnetic Separator) (Section 2.2.3).
- C. Place the Non-Ferrous Metal Recovery System in Service (Eddy Current Separator) (section 2.2.4)
- D. Starting and Operating VC-1 (2.2.5)
- E. Place the boiler sifting drag chain conveyors in service (Section 2.2.6)
- F. Place the boiler flyash screw conveyors in service (Section 2.2.7)
- G. Place a fly ash Transport and conditioning system in service (Section 2.2.8)



Wheelabrator McKay Bay Inc.

**2.2.2 Place the Ash Disposal System and Vibration Conveyors in Service Without Metal Recovery**

**NOTE: VC-2(A) is the normally operating vibration conveyor for transporting ash and metal to the ash management building. VC-1(A) is the back up when the grizzly scalper or system belts are down for maintenance.**

**CAUTION: Operators must stay clear of rotating machinery and moving belts. Plant personnel should never stand or work on a moving belt or conveyor.**

**NOTE: To run ash & metal to the ash pile without non ferrous metal recovery for maintenance reasons Bypass plate needs to be removed from the VC-10 to allow dumping of ash and metal directly to BC-5**

ACTION	LOCATION	VERIFICATION
1. VERIFY that the vibrating conveyors, belts, grizzly scalper, and vibratory feeder are free from obstructions and all personnel are clear of the equipment.	Local	Walk down conveyors and verify system clear.
2. INFORM plant personnel that the equipment is to be put into service.	Control Room	Plant personnel acknowledge startup of system
3. VERIFY roll-off container in place under grizzly scalper.	Local	Check roll-off container in place.
4. START BC-5 from the DCS.	Control Room	Horn in the Ash Handling Building sounds for 10 seconds BC-5 starts.
5. VERIFY bypass piece removed from VC-10	Local	Walk down VC-10 and verify system ready for startup.
6. START VC-10 from the DCS	Control Room	Horn in the Ash Handling Building sounds for 10 seconds VC-10 starts.

Wheelabrator McKay Bay Inc.

**2.2.2 Place the Ash Disposal System and Vibration Conveyors in Service Without Metal Recovery (Cont.)**

**NOTE: Horn will not sound if VC-10 started within 60 seconds of starting BC-5**

<b>ACTION</b>	<b>LOCATION</b>	<b>VERIFICATION</b>
7. START Spreader Feeder from the DCS.	Control Room	Horn in the Ash Handling Building sounds for 10 seconds. Spreader feeder starts
8. START BC-3 from the DCS.	Control Room	Ash Conveyor Gallery Horn sounds for 10 seconds. Inclined Belt Conveyor BC-3 starts.
9. START Vibratory Feeder from the DCS	Control Room	Scalper Building Horn sounds for 10 seconds. Vibratory Feeder Starts.
10. START Grizzly Scalper from the DCS	Control Room	Grizzly Scalper Starts
11. START VC-2 from the DCS	Control Room	VC area warning horn sounds for 10 seconds. VC-2 conveyor starts.
12. START VC-2A from the DCS and select AUTO START ENABLE	Control Room	VC-2A starts 5 seconds after VC-2 Starts.
13. START ash expeller per OP-2 section 2.2.4.3	Local	Ash expeller operating

Wheelabrator McKay Bay Inc.

**2.2.3 Place the Ferrous Metal Recovery System in Service (Magnetic Separator)**

**NOTE: To run ash & metal to the ash pile without non ferrous metal recovery for maintenance reasons Bypass plate needs to be removed from the VC-10 to allow dumping of ash and metal directly to BC-5**

ACTION	LOCATION	VERIFICATION
1. BC-5 and VC-10 in Service Per section 2.2.2, Bypass plate for VC-10 in bypass.	Local	Walk down ash system.
2. VERIFY that the VC-10 and the Magnetic Separator are free from obstructions and all personnel are clear of the equipment.	Local	Walk down the VC-10 and the Magnetic Separator and verify system clear.
3. START Magnetic Separator on DCS	Control Room	Indicates energized on DCS, Magnetic Separator starts to rotate.
4. START Magnetic Separator Electromagnet on DCS	Control Room	Indicates energized on DCS. Power indicated on the Magnetic Separator Control panel 01-MM-0220
5. Continue to start up ash system per section 2.2.2 steps 7-13	Control Room	

Wheelabrator McKay Bay Inc.

**2.2.4 Place the Non-Ferrous Metal Recovery System in Service (Eddy Current Separator)**

**NOTE: For non-ferrous metal processing bypass plate needs to be installed on the VC-10 to allow material to move to the Vibrating Feeder Screener (VFS-1) an onto the Eddy Current Separator ECS-1**

**NOTE: Horn will not sound if VS-1 (Non-Ferrous Vibrating Screener) or any other machine in the Non-Ferrous System if any of the equipment is started within 60 seconds of starting BC-5**

<b>ACTION</b>	<b>LOCATION</b>	<b>VERIFICATION</b>
6. VERIFY that the vibrating conveyors, belts, grizzly scalper, and vibratory feeder are free from obstructions and all personnel are clear of the equipment.	Local	Walk down conveyors and verify system clear.
7. INFORM plant personnel that the equipment is to be put into service.	Control Room	Plant personnel acknowledge startup of system
8. VERIFY bypass piece installed on VC-10	Local	Walk down and verify VC-10 ready for startup.
9. VERIFY roll-off container in place under grizzly scalper.	Local	Check roll-off container in place.
10. VERIFY non-ferrous hopper in place in Ash building middle bunker.	Local	Check non Ferrous hopper in place.
11. START BC-5 from the DCS.	Control Room	Horn in the Ash Handling Building sounds for 10 seconds BC-5 starts.
12. START VS-1 (Non-Ferrous Vibrating Screener) from the DCS.	Control Room	Horn in the Ash Handling Building sounds for 10 seconds VS-1 starts.

**NOTE: Horn will not sound if VS-1 (Non-Ferrous Vibrating Screener) or any other machine in the Non-Ferrous System if any of the equipment is started within 60 seconds of starting BC-5**

Wheelabrator McKay Bay Inc.

**2.2.4 Place the Non-Ferrous Metal Recovery System in Service (Eddy Current Separator) Cont.**

<b>ACTION</b>	<b>LOCATION</b>	<b>VERIFICATION</b>
13. START ECS-1 (Eddy Current Separator) from the DCS.	Control Room	Horn in the Ash Handling Building sounds for 10 seconds ECS-1 starts.
14. START VFS-1 (Vibrating Feeder Screener) on the DCS.	Control Room	Horn in the Ash Handling Building sounds for 10 seconds VFS-1 starts.
15. START VC-10 from the DCS	Control Room	Horn in the Ash Handling Building sounds for 10 seconds VC-10 starts.

**NOTE: Horn will not sound if VC-10 started within 60 seconds of starting BC-5**

16. START Magnetic Separator on DCS	Control Room	Indicates energized on DCS, Magnetic Separator starts to rotate.
17. START Magnetic Separator Electromagnet on DCS	Control Room	Indicates energized on DCS. Power indicated on the Magnetic Separator Control panel 01-MM-0220
18. Continue to start up ash system per section 2.2.2 steps 7-13	Control Room	

Wheelabrator McKay Bay Inc.

**2.2.5 Starting and Operating VC-1**

**NOTE: VC-2 is the normally operating vibration conveyor for transporting ash and metal to the ash management building. VC-1 is the back up when the grizzly scalper or system belts are down for maintenance.**

**CAUTION: Operators must stay clear of rotating machinery and moving belts. Plant personnel should never stand or work on a moving belt or conveyor.**

ACTION	LOCATION	VERIFICATION
1. VERIFY that the vibrating conveyors, are free from obstructions and all personnel are clear of the equipment.	Local	Walk down conveyors and verify system clear.
2. INFORM plant personnel that the equipment is to be put into service.	Control Room	Plant personnel acknowledge startup of system
3. VERIFY roll-off container in place in scalper building.	Local	Check roll-off container in place.
4. START VC-1 from the DCS	Control Room	VC area warning horn sounds for 10 seconds. VC-1 conveyor starts.
5. START VC-1A from the DCS and select AUTO START ENABLE	Control Room	VC-1A starts 5 seconds after VC-1 Starts.
6. START ash expeller per OP-2 section 2.2.4.3	Local	Ash expeller operating

Wheelabrator McKay Bay Inc.

**2.2.6 Place the Boiler Sifting Drag Chain Conveyors in Service**

**CAUTION: Operators must stay clear of rotating machinery and moving chains.**

<b>ACTION</b>	<b>LOCATION</b>	<b>VERIFICATION</b>
1. VERIFY that the Sifting Drag Chain Conveyor and the Sifting Screw are free from obstructions and all personnel are clear of the equipment.	Local	Walk down the Sifting Drag Chain and the Sifting Screw and verify system clear.
2. INFORM plant personnel that the equipment is to be put into service.	Control Room	Plant personnel acknowledges startup of system
3. VERIFY proper water level on Sifting Drag Chain Conveyor.	Local	Check level and verify wastewater lined up to level controller.
4. POSITION or VERIFY gate selected to the operating Vibratory Conveyor	Local	Sifting chain lined up to operating VC.
5. START unit Sifting Drag Chain on DCS	Control Room	Sifting Drag Chain Starts.
6. START unit Sifting Screw on DCS	Control Room	Sifting Screw Starts.

**NOTE: Sifting Screw will not start unless the Sifting Drag Chain is operating.**

**2.2.7 Place the Boiler Flyash Screw Conveyors in Service**

**CAUTION: Operators must stay clear of rotating machinery**

<b>ACTION</b>	<b>LOCATION</b>	<b>VERIFICATION</b>
1. VERIFY that the Boiler Fly Ash Screw Conveyors are free from obstructions and all personnel are clear of the equipment.	Local	Walk down the Boiler Fly Ash Screw Conveyors and verify system clear.
2. VERIFY service air lined up to dump valves	Local	Check valve line up and verify air supply
3. START unit East Flyash Screw on DCS	Control Room	East Flyash Screw Starts.

Wheelabrator McKay Bay Inc.

**2.2.7 Place the Boiler Flyash Screw Conveyors in Service Cont.**

<b>ACTION</b>	<b>LOCATION</b>	<b>VERIFICATION</b>
4. START unit West Flyash Screw on DCS	Control Room	West Flyash Screw Starts.
5. <b>2</b> SELECT AUTO on DCS for Dump Valves for east and west Dropout Hoppers and Economizer Hoppers	Control Room	Dump Valves open and shut.

**NOTE: Dump Valves will not open unless Flyash Screw is operating.**

**2.2.8 Placing the Fly Ash Transport and Conditioning System in Service**

**NOTE: Operation of both Flyash Mixers/Conditioners (A&B) and Flyash Transport Conveyors are similar.**

<b>ACTION</b>	<b>LOCATION</b>	<b>VERIFICATION</b>
1. VERIFY that the Flyash Mixer (conditioner) and drag chains to be operated are free from obstructions and all personnel are clear of the equipment.	Local	CHECK the Boiler Fly Ash Mixer and walk down transport drag chains to verify system clear.
2. SELECT the position of Flyash Conditioner "A" Diverter to send ash to whichever vibratory conveyor is running on DCS.	Control Room	DCS graphic shows flyash gate selected to the proper VC.
3. START Flyash Conditioner "A" mixer on DCS.	Control Room	Mixer Starts
4. START the feeder on DCS	Control Room	Feeder starts unless surge bin has a low level.

If the Flyash Conditioner "A" surge bin is above the low level, feeder starts at low speed. If the Flyash Conditioner "A" surge bin is above the high level, feeder starts at high speed. If the Flyash Conditioner "A" surge bin is below the low level, the feeder will not start until 60 seconds after the low level clears. When the feeder starts the Flyash Conditioner "A" feeder inlet slide gate will open automatically and primary spray valve will open after 10-second delay. When the feeder stops, the slide gate will close automatically and the primary spray valve will close after a 10-second delay. Low level in the surge bin will stop the feeder and close the slide gate.



Wheelabrator McKay Bay Inc.

**2.2.8 Placing the Fly Ash Transport and Conditioning System in Service**  
**Cont**

<b>ACTION</b>	<b>LOCATION</b>	<b>VERIFICATION</b>
5. START Flyash Transfer Drag Conveyor 3A on DCS	Control Room	Flyash Transfer Drag Conveyor starts.
6. START Flyash Collecting Conveyor "A" on DCS.	Control Room	Flyash Collecting Conveyor starts.
7. START SDA Drag Conveyor on DCS	Control Room	SDA Drag Conveyor starts
8. VERIFY service air lined up to SDA slide gate.	Local	Check valve line up and air available
9. PLACE SDA slide gate in AUTO on DCS	Control Room	SDA slide gates start to cycle in AUTO.

**NOTE: For the SDA slide gate to operate the Unit SDA Drag Chain Conveyor must be operating.**

10. START Unit FF (Fabric Filter) Gather Screw Conveyors "A" & "B" on DCS.	Control Room	Gather Screw Conveyors start.
11. VERIFY service air line up to Unit FF Double Dump Valves	Local	Check valve line up and air available
12: PLACE FF Double Dump Valves in AUTO on DCS	Control Room	FF double dump valves start to cycle in AUTO.

**NOTE: For the FF Double Dump Valves to operate the Unit Gather Screw Conveyors must be operating.**

Wheelabrator McKay Bay Inc.

**3.0 SYSTEM NORMAL OPERATIONS**

**3.1 Normal Operation**

<b>ACTION</b>	<b>LOCATION</b>	<b>VERIFICATION</b>
1. VERIFY that all conveyors move smoothly without binding or unusual noise or vibration.	Local	Check for noise and vibration
2. CHECK the condition of the conveyors for excessive wear of belts	Local	Look for excess wear
3. VERIFY that all drive motors, couplings, and drive belts are free from ash buildup.	Local	Check and clean out ash buildup
4. PERIODICALLY CHECK all belts, idlers, conveyors, and all moving parts for freedom of motion and proper lubrication.	Local	Visually verify proper operation and freedom of movement.
5. CHECK that all hoppers, slide gates, ash expellers, double dump valves, and discharge areas are not jammed with large debris and material flow is not hindered.	Local	Visually check operation
6. PERIODICALLY CHECK all chutes for material stoppages.	Local	Look through inspection doors
7. PERIODICALLY CHECK the hydraulic oil-and-air-activated cylinders for proper operation and proper sealing.	Local	Feel around doors for air leaks
8. PERIODICALLY CHECK all supports and springs for wear and tightness	Local	Check for broken springs on vibrating equipment
9. CHECK the fly ash conditioners for proper operation, and the water spay nozzles	Local	Visually check for plugged nozzles and mixer operation

Wheelabrator McKay Bay Inc.

**3.2 Switching the Fly Ash Mixers (A to B)**

ACTION	LOCATION	VERIFICATION
1. VERIFY that the Flyash Mixer to be operated is free from obstructions and all personnel are clear of the equipment.	Local	CHECK the Boiler Fly Ash Mixer to verify system clear.
2. SELECT the position of Flyash Conditioner "B" Diverter to send ash to whichever vibratory conveyor is running on DCS.	Control Room	DCS graphic shows flyash gate selected to the proper VC.

**NOTE: If the Diverter gate does not reach the desired position within 5 seconds, the DCS generates an alarm GATE FAIL.**

3. START Flyash Conditioner "B" mixer from the DCS	Control Room	Mixer Starts
4. START the "B" feeder	Control Room	Feeder starts unless surge bin has a low level.
5. CLOSE Flyash Transfer Drag Conveyor Slide Gates on DCS to allow fly ash to flow to "B" surge bin.	Control Room	Slide gates go shut.
6. STOP "A" flyash mixer when surge bin is empty.	Control Room	Mixer stops.

**3.3 Switching the Fly Ash Transfer Drag Conveyors (3A to 3B)**

1. VERIFY that the Flyash transfer drag conveyor 3B is free from obstructions and all personnel are clear of the equipment.	Local	Walk down transport drag chains to verify system clear.
2. VERIFY Flyash Conditioner "A" Conveyor 3B slide gate is open if "A" mixer operating.	Control Room	GATE open on DCS. IF closed chain will not start unless "B" mixer operating.
3. START Flyash transfer drag Conveyor 3B	Control Room	Transfer drag conveyor 3B starts
4. STOP Flyash transfer drag Conveyor 3A when chain is empty.	Control Room	Transfer drag conveyor 3A stops

Wheelabrator McKay Bay Inc.

**4.0 SYSTEM SHUTDOWN**

**4.1 Remove the Bottom Ash Collecting System from Service**

**NOTE: The bottom ash system is common to all boilers and is normally kept in service until all ash has been removed from the grates and all flyash has been run out of the system.**

**NOTE: All conveyors should be "RUN OUT", that is all material discharged from the conveyor before it is stopped**

**4.4.1 Temporary Stop to Empty Roll-Off Container**

<b>ACTION</b>	<b>LOCATION</b>	<b>VERIFICATION</b>
1. VERIFY roll-off container full.	Local	Visually check level
2. PUSH "TEMPORARY STOP" Pushbutton at the roll-off area of the Scalper building or on DCS.	Local/Control Room	Operating VC stops for 10 minutes to dump roll-off truck.
3. STOP operating ash expeller pumps	Control Room	Expellers stop
4. STOP the Vibratory Conveyor on the DCS if the operation will take longer than 10 minutes.	Control Room	Operating VC and flyash mixer stops.
5. START Vibratory Conveyor when roll-off container back in position.	Control Room	Conveyor starts.
6. START expeller pumps for all operating units	Control Room	Expellers start to cycle

Wheelabrator McKay Bay Inc.

**4.4.2 Bottom Ash System Shutdown**

**NOTE: Bottom ash system is not shutdown unless Flyash system is not operating. If Vibratory Conveyors are shutdown, Flyash mixers will stop on system interlock.**

**NOTE: If any boilers are on-line, the system should only be stopped temporarily unless there are extensive maintenance problems. In this case, the boiler bottom and fly ash systems must be aligned to VC-1 to dump directly into a roll-off container.**

<b>ACTION</b>	<b>LOCATION</b>	<b>VERIFICATION</b>
1. VERIFY ash off grates and system can be shutdown	Local	Visually check for ash off grates on all units.
2. VERIFY fly ash collecting system no longer needed	Local/Control Room	Fire off grates on all units. Air Pollution Control system shutdown. Surge bins empty.
3. STOP the Sifting Screw(s) on the DCS when all material run out.	Control Room	Sifting Screw stops
4. STOP the Sifting Drag Chain Conveyor(s) on the DCS when all material run out	Control Room	Sifting Drag Chain Conveyor stops.
5. SELECT "OFF" on DCS for Flyash Screw Dump valves	Control Room	Flyash Screw Dump valves no longer cycle and stay shut.
6. STOP unit east and west Flyash Screws on the DCS when all material run out.	Control Room	Flyash Screw Conveyors stop.
7. STOP unit ash expeller when ash has stopped flowing from the expeller per OP-2 section 4.2.2	Local	Ash expeller shutdown. Pump indicates OFF on DCS.

Wheelabrator McKay Bay Inc.

**4.4.2 Bottom Ash System Shutdown Cont.**

<b>ACTION</b>	<b>LOCATION</b>	<b>VERIFICATION</b>
8. STOP the Vibratory Conveyors on the DCS after all bottom ash and fly ash has run off the conveyors.	Control Room	Vibratory conveyors stop
9. STOP the Grizzly Scalper on the DCS when all material has run off	Control Room	Grizzly scalper stops
10. STOP the Vibratory Feeder on the DCS when all material has run off	Control Room	Vibratory feeder stops
11. STOP the Incline Belt BC-3 on the DCS when all material has run off.	Control Room	BC-3 stops
12. STOP the Spreader Feeder on the DCS when all material has run off	Control Room	Spreader feeder stops
13. STOP the Magnet and Magnetic Separator on the DCS	Control Room	Separator stops, voltage goes to zero on panel.
14. STOP the Vibrating Feeder Screener VFS-1 on the DCS	Control Room	VS-1 stops
15. STOP the Eddy Current Separator ECS-1	Control Room	ECS-1 stops
16. STOP the Non-Ferrous Vibrating Screener VS-1	Control Room	VS-1 stops
17. STOP the BC-5 on the DCS	Control Room	BC-5 stops.

**NOTE: If any piece of equipment is stopped out of order, the conveyors upstream will trip on interlock.**

Wheelabrator McKay Bay Inc.

**4.2 Removing the Fly Ash Transport and Conditioning System from Service**

**NOTE: The Fly Ash system is common to all boilers and is normally kept in service until all ash has been removed from the grates, air pollution control systems have been shutdown (OP-5) and all flyash has been run out of the system.**

<b>ACTION</b>	<b>LOCATION</b>	<b>VERIFICATION</b>
1. VERIFY Fly Ash Transport and Conditioning System can be shutdown.	Local/Control Room	Fire off grates on all units. Air pollution control system shutdown. Surge bins empty.
2. SELECT "OFF" on FF (Fabric Filter) double dump valves on DCS.	Control Room	FF Double Dump valves no longer cycle and stay shut.
3. STOP FF Gather Screw Conveyor "A" and "B" on the DCS on each unit when all flyash has run out.	Control Room	FF gather screw conveyors stop.
4. STOP unit SDA Drag Conveyor on DCS when all flyash has run out.	Control Room	SDA drag conveyor stops. Slide gate selects "OFF" on DCS and stays shut.
5. STOP operating Flyash Collecting Conveyor (A or B) on DCS when all flyash has run out.	Control Room	Flyash collecting conveyor stops.
6. STOP operating Flyash Transfer Conveyor (A or B) on DCS when all fly ash has run out.	Control Room	Flyash transfer conveyor stops.

**NOTE: If any piece of equipment is stopped out of order, the conveyors upstream will trip on interlock.**

7. VERIFY surge bin level on operating flyash mixer.	Local	Check level at surge bin.
8. SELECT "LOW LEVEL OVERRIDE" for surge bin on DCS for mixer feeder to run surge bin empty.	Control Room	DCS graphic indicates "ENABLED". Feeder runs with low level alarm indicated on surge bin.

Wheelabrator McKay Bay Inc.

**4.3 Removing the Fly Ash Transport and Conditioning System from Service**  
**Cont.**

<b>ACTION</b>	<b>LOCATION</b>	<b>VERIFICATION</b>
9. VERIFY surge bin empty	Local	Check level at surge bin
10. DISABLE "LOW LEVEL OVERRIDE" on DCS	Control Room	DCS graphic indicates "DISABLED". Feeder stops with low level alarm indicated on surge bin.
11. STOP Flyash Conditioner on DCS when all flyash has run out of the mixer.	Control Room	Flyash mixer stops
12. CLEAN out flyash mixer.	Local	



Wheelabrator McKay Bay Inc.

**5.0 ALARM RESPONSES**

**5.1 Summary of Alarms**

**CONTROL ROOM ALARMS ON DCS**

1. Surge Bin level High/High-High
2. Surge Bin Level Low
3. Dump Valve Failed to Open/Close
4. Belt Runoff BC-3, BC-5
5. Vibration High Stroke/Over stroke Trip
6. Speed Switch Fault.

Wheelabrator McKay Bay Inc.

7-1

**ALARM RESPONSE**

**NUMBER 01-LAHH-0325**

Alarm Title: SURGE BIN LEVEL HIGH/HIGH-HIGH

Initiating Device: DCS alarm 01-LAHH-0325 Surge Bin Level Detector

Set point: Top of Surge Bin Reset : Level Below Detector

A. <u>Possible Cause(s) of Alarm</u>			
1.		Flyash Transfer Drag Conveyor Dumping flyash to off-line surge bin.	
2.		Flyash Mixer Feeder plugged or not operating.	
3.		Level indication malfunction.	
B. <u>Consequences</u>			
1.		Flyash Transfer Drag Conveyor and all upstream flyash conveyors trip.	
C. <u>Immediate Operator Action Control Room</u>		C. <u>Immediate Operator Action Outside Operator</u>	
1.		1.	
Verify alarm on DCS and flyash transfer drag conveyor and upstream conveyors tripped.		Verify high level on surge bin.	
2.		2.	
Dispatch outside operator to verify levels and for standby fly ash mixer start-up		Start up standby fly ash mixer	
3.		3.	
Start Stand-by flyash mixer and restart fly ash flow per OP-7 section 3.2.		Verify startup of mixer and proper operation of the system	
D. <u>Follow-up Operator Action</u>			
1.		Notify Shift Supervisor	
2.		Restart all upstream flyash conveyors per OP-7 section 2.2.3	

Wheelabrator McKay Bay Inc.

7-2

**ALARM RESPONSE**

**NUMBER 01-LIC-0327**

Alarm Title: SURGE BIN LEVEL LOW

Initiating Device: DCS alarm 01-LIC-0327 Surge Bin Level Detector

Set point: Bottom of Surge Bin Reset : Level Above Detector

A. <u>Possible Cause(s) of Alarm</u>			
1.		Surge Bin Empty	
2.		Low Level Override "Enabled" on DCS	
3.		Level indication malfunction.	
B. <u>Consequences</u>			
1.		Feeder stops and slide gate closes.	
2.		Excess water flow to mixer and ash system.	
C. <u>Immediate Operator Action Control Room</u>		C. <u>Immediate Operator Action Outside Operator</u>	
1.		1.	
2.		2.	
3.			
D. <u>Follow-up Operator Action</u>			
1.		Notify Shift Supervisor	
2.		Clean fly ash mixer to remove possible plugs in system.	
3.		Contact E&I to repair level detector problem	

Wheelabrator McKay Bay Inc.

**7-3**

**ALARM RESPONSE**

**NUMBER 04-2A-1218A**

Alarm Title: DUMP VALVE / SLIDE GATE FAILED TO OPEN/CLOSE

Initiating Device: DCS alarm 04-2A-1218A

Set point: 15 seconds without reaching limit Reset : Valve fully opens/closes

A. <u>Possible Cause(s) of Alarm</u>			
1.		No service air to valve	
2.		Failed limit switch	
3.		Stuck valve	
B. <u>Consequences</u>			
1.		Plugged FF or SDA Hoppers with high level alarms	
2.		Plugged Dropout or Economizer Hoppers	
3.		Reduced air flow through boiler	
C. <u>Immediate Operator Action Control Room</u>		C. <u>Immediate Operator Action Outside Operator</u>	
1.		1. Verify alarm on DCS	
2.		2. Dispatch outside operator to valve to check valve line up.	
1.		1. Verify air lined up to valve	
2.		2. Stroke valve manually by overriding the air solenoid valve	
D. <u>Follow-up Operator Action</u>			
1.		Notify Shift Supervisor	
2.		If solenoid valve needs replacement; notify E&I	
3.		Decrease unit load if needed to lengthen time until valve can be repaired.	
4.		If Dump valve stuck on FF, isolate the compartment if needed until repaired	

Wheelabrator McKay Bay Inc.

7-4

**ALARM RESPONSE**

**NUMBER 01-ZAR-0348**

Alarm Title: BELT RUNOFF ALARM/TRIP BC-3, BC-5

Initiating Device: DCS alarm 01-ZAR-0348 Belt Side Travel Switch

Set point: 15 sec. on switch for alarm 60 sec. for trip Reset : Belt clear of switch

A. <u>Possible Cause(s) of Alarm</u>			
1.		Belt overloaded	
2.		Belt alignment incorrect	
3.		Belt scraper too tight	
4.		Object jammed in roller	
B. <u>Consequences</u>			
1.		All upstream conveyors trip with belt.	
2.		Damaged belt	
C. <u>Immediate Operator Action Control Room</u>		C. <u>Immediate Operator Action Outside Operator</u>	
1.		1.	
2.		2.	
		3.	
D. <u>Follow-up Operator Action</u>			
1.		Notify Shift Supervisor	
2.		If belt can not be restarted. Start VC-1 per OP-7 section 2.2.2.2	
3.		When belt tracking properly. Restart ash system.	

Wheelabrator McKay Bay Inc.

7-5

**ALARM RESPONSE**

**NUMBER 01-VAL-0339**

Alarm Title: VIBRATION HIGH STROKE/OVERSTROKE TRIP

Initiating Device: DCS alarm 01-VAL-0339 Vibration Monitor

Set point: Abnormal vibration due to overload Reset : Vibration Normal

A.		<u>Possible Cause(s) of Alarm</u>	
1.		Vibratory conveyor/grizzly/spreader feeder/ finger screen overloaded	
2.		Broken Spring	
B.		<u>Consequences</u>	
1.		All upstream conveyors trip on overstroke.	
2.		Damaged Conveyor	
3.		Overloaded Belts	
C.		<u>Immediate Operator Action Control Room</u>	C.
			<u>Immediate Operator Action Outside Operator</u>
1.		Verify alarm on DCS	1. Check load on Vibratory Conveyor
2.		Dispatch outside operator to conveyor	2. Jog conveyor and scrape pan to clear alarm
D.		<u>Follow-up Operator Action</u>	
1.		Notify Shift Supervisor	
2.		If conveyor can not be restarted. Start VC-1 per OP-7 section 2.2.2.2 direct ash to roll off container	
3.		When conveyor running, restart upstream conveyors	

Wheelabrator McKay Bay Inc.

7-6

**ALARM RESPONSE**

**NUMBER 02-SAL-1303**

Alarm Title: SPEED SWITCH FAULT ON ROTATING EQUIPMENT

Initiating Device: DCS alarm 01-SAL-1303

Set point: 5 Seconds at zero speed on shaft Reset : Equipment rotating

A. <u>Possible Cause(s) of Alarm</u>			
1.	Overloaded or jammed equipment		
2.	Broken drive belt		
3.	Switch Failure		
4.	Distance from pick-up excessive.		
B. <u>Consequences</u>			
1.	All upstream conveyors trip		
2.	Plugged Hoppers		
3.	Siftings or flyash not being removed from furnace.		
C.	<u>Immediate Operator Action Control Room</u>	C.	<u>Immediate Operator Action Outside Operator</u>
1.	Verify alarm on DCS	1.	Check load on Vibratory Conveyor
2.	Dispatch outside operator to location of trip	2.	Verify condition of drive belt. If broken replace belt
		3.	Check equipment for jam. Clear jam & restart.
D. <u>Follow-up Operator Action</u>			
1.	Notify Shift Supervisor		

Wheelabrator McKay Bay Inc.

**ALARM RESPONSE CONT.**

**NUMBER 02-SAL-1303**

Alarm Title: SPEED SWITCH FAULT ON ROTATING EQUIPMENT

2.	If due to failure of motor or gearbox notify maintenance.
3.	When equipment running, restart upstream equipment



Wheelabrator McKay Bay Inc.

**6.0 APPENDIX**

**6.1 System Diagrams**

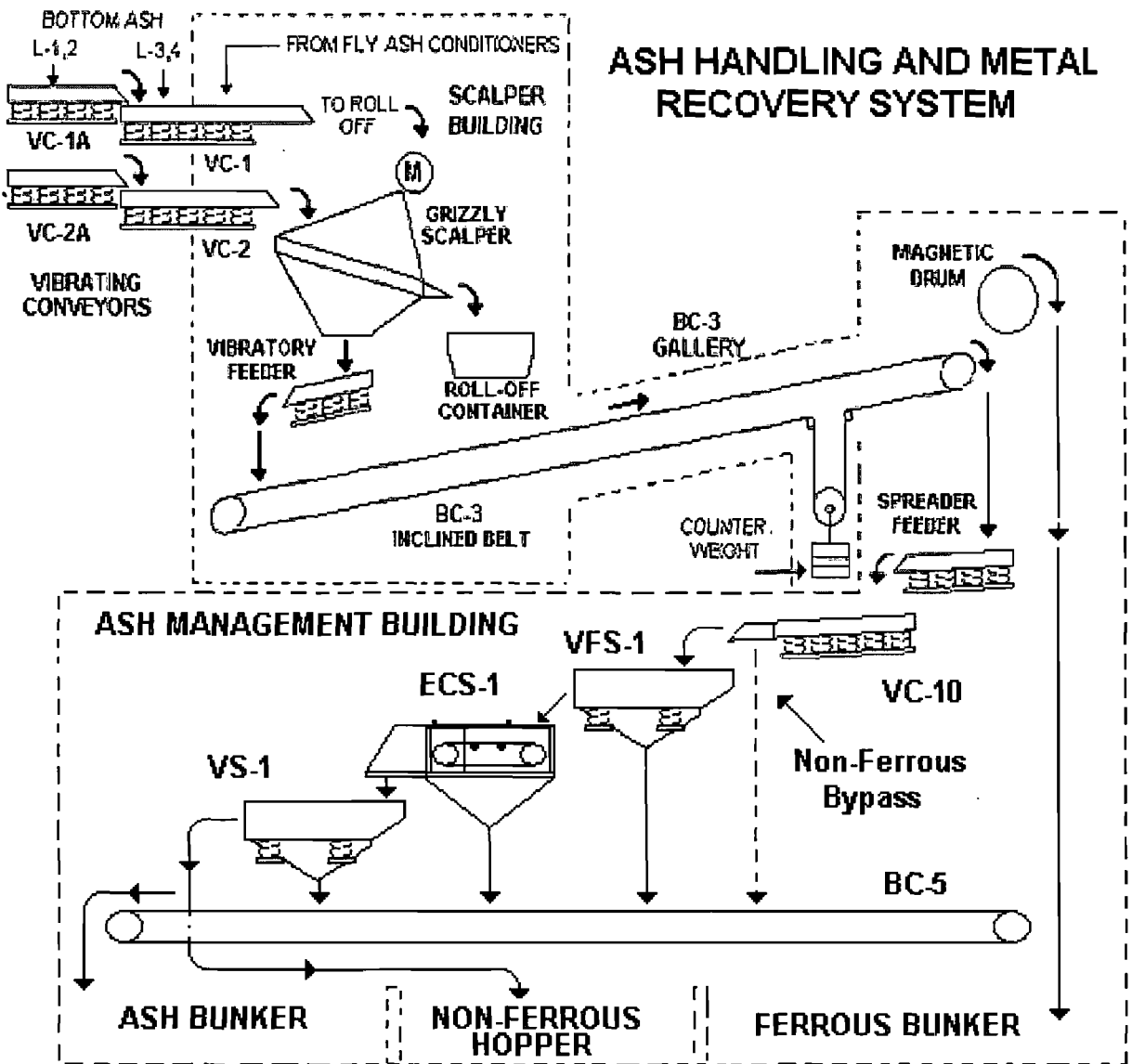

# FLY ASH TRANSPORT SYSTEM

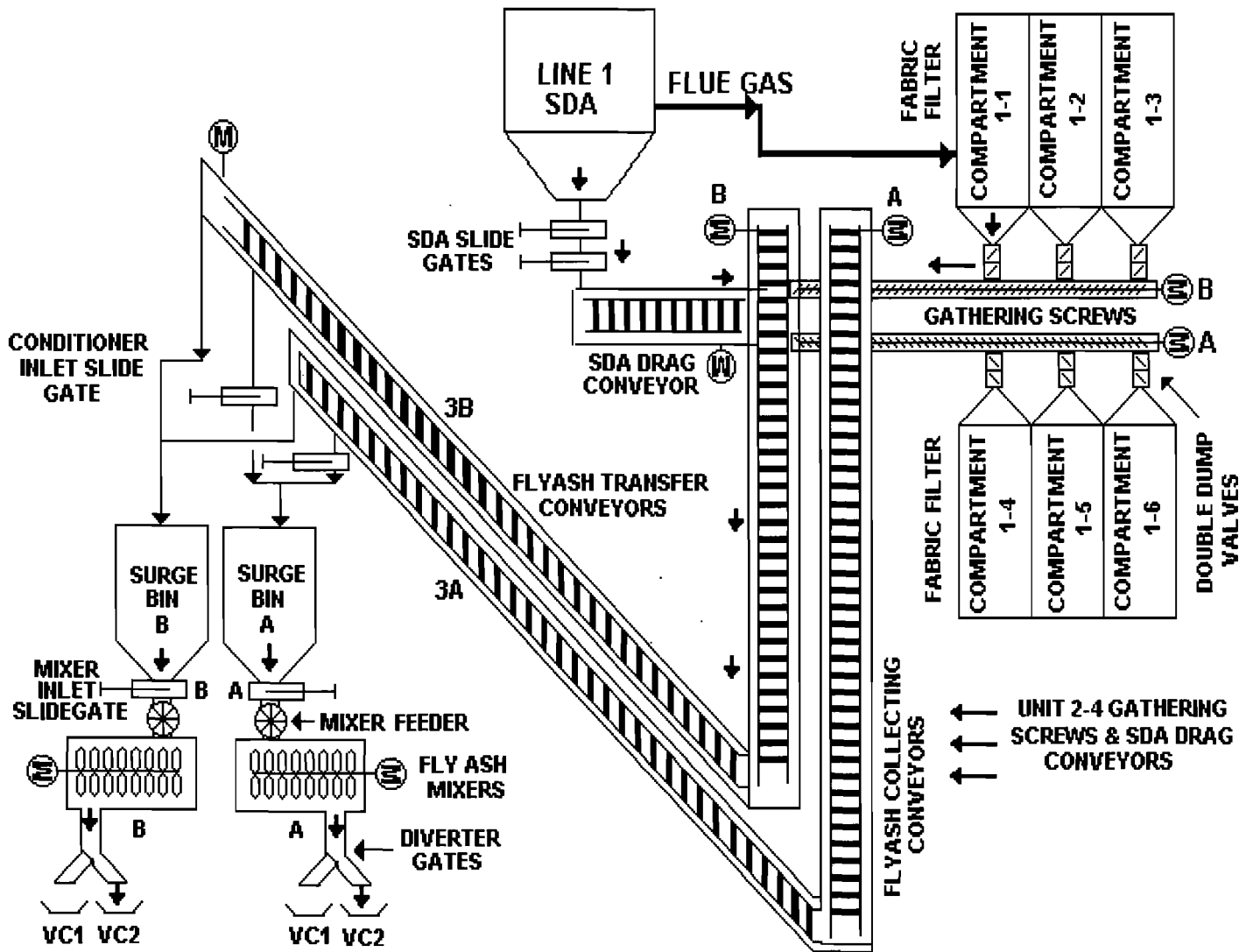

35

Wheelabrator McKay Bay Inc.

Operating Procedures No. 7  
 Ash Handling System  
 Date: June 10, 2009  
 Rev: 5

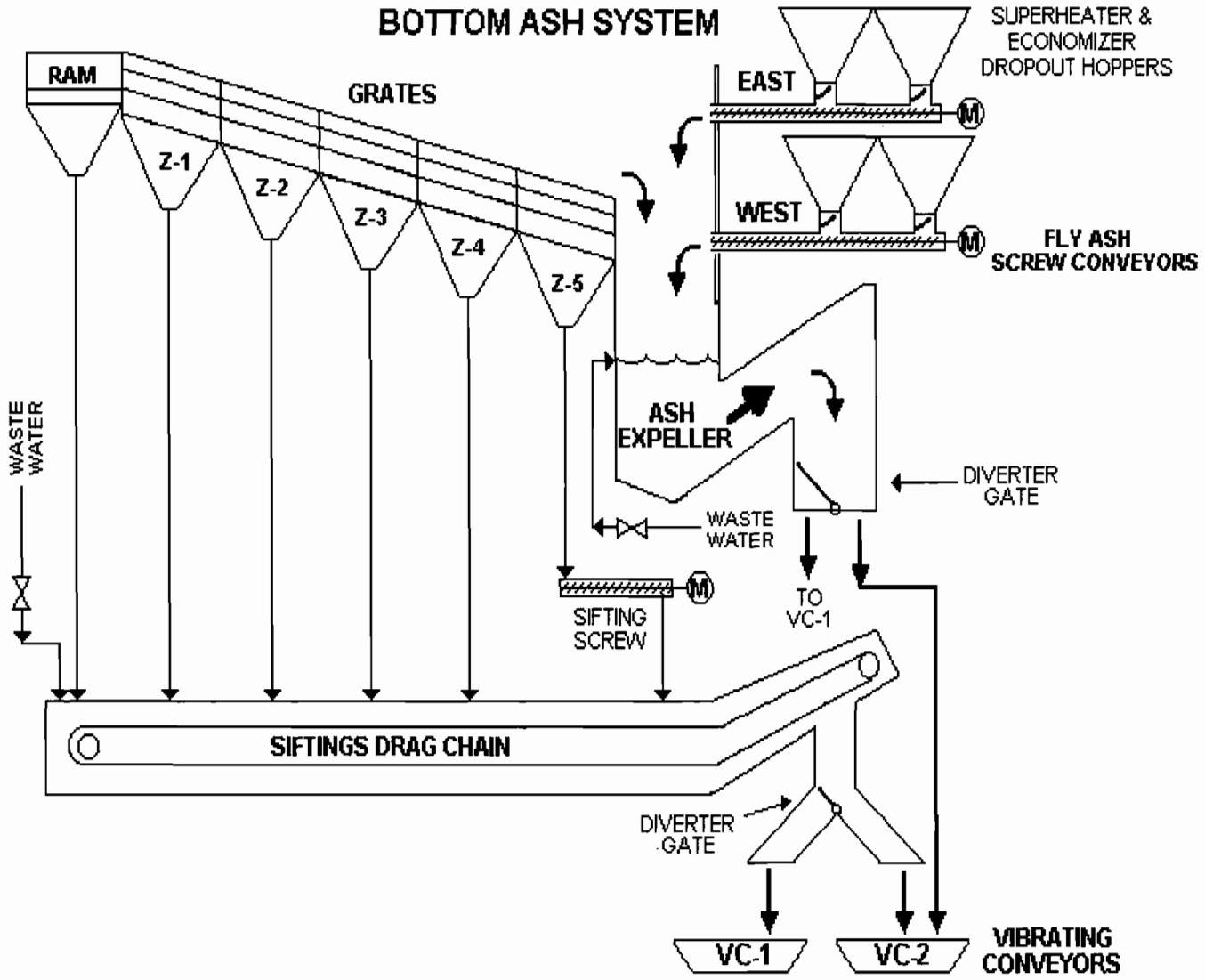

36

Wheelabrator McKay Bay Inc.

Operating Procedures No. 7  
 Ash Handling System  
 Date: June 10, 2009  
 Rev: 5

**WHEELABRATOR McKAY BAY, INC.**

**OPERATING PROCEDURES**

**OP - 15: DISTRIBUTED CONTROL SYSTEM**

## **CONTENTS**

1.0	INTRODUCTION .....	3
1.1	Purpose and Scope .....	3
1.2	References .....	3
1.2.1	Electrical Block Diagram.....	4
1.2.2	Manuals.....	4
1.3	Operational Outline .....	4
2.0	SYSTEM STARTUP.....	6
2.1	Pre-operational Instructions.....	6
2.1.1	Prerequisites.....	6
2.1.2	Precautions and Limitations.....	6
2.1.3	Pre-start Checklist .....	6
2.2	System Startup Instructions.....	6
2.2.1	Milestones.....	6
2.2.2	Distributed Control System Startup.....	7
3.0	SYSTEM NORMAL OPERATION.....	7
3.1	Normal Operation .....	7
4.0	SYSTEM SHUTDOWN .....	7
4.1	Distributed Control System Shutdown .....	7
5.0	ALARM RESPONSES .....	8
5.1	Summary of Alarms .....	8
6.0	SYSTEM DIAGRAM .....	10

WHEELABRATOR MCKAY BAY, INC.

**1.0 INTRODUCTION**

**1.1 Purpose and Scope**

This procedure provides personnel with a standard procedure for operation of the Distributed Control System.

The Distributed Control System's primary functions are to:

- A. Provide for the operation and control of the plants systems connected to the network.
- B. Provide for logging of data and alarms
- C. Signal the operator when alarm limits have been reached.
- D. Provide for system trips or for the shutdown of equipment in an unsafe or limit condition.

The following systems and subsystems interface with the Distributed Control System:

A. From the Distributed Control System:

- 1) Boiler – Combustion System
- 2) Boiler – Steam Generation System
- 3) Air Pollution Control System
- 4) Waste Water System
- 5) Ash Handling System
- 6) Auxiliary Fuel System
- 7) Steam Distribution System
- 8) Electrical Distribution System

B. To the Distributed Control System:

- 1) Boiler – Combustion System
- 2) Boiler – Steam Generation System
- 3) Air Pollution Control System
- 4) Service Air System
- 5) Ash Handling System

WHEELABRATOR MCKAY BAY, INC.

- 6) Waste Water System
- 7) Auxiliary Fuel System
- 8) Electrical Distribution System
- 9) Refuse Receiving and Handling System
- 10) Condensate System
- 11) Feedwater System
- 12) Steam Distribution System
- 13) Closed Cooling Water System
- 14) Turbine System

**1.2 References**

**1.2.1 Electrical Block Diagram**

- A. 01-26-0500 Distributed Control System

**1.2.2 Manuals**

- A. Mckay Bay Refuse to Energy Facility Retrofit Project Distributed Control System VOL 1—11.

**1.3 Operational Outline**

The McKay Bay Refuse to Energy facility is controlled from a main control room located on the 5<sup>th</sup> floor using a Bailey INFI 90 Microprocessor Based, Distributed control System. This system consist of one network server (CON1), one back up server (CON2), two Client Consoles (CON 3&4), one Engineering Operator Station (CON5) and 15 PCU cabinet sets, which are located in the Control Room, East Electrical Room, West Electrical Room and Room 322. Additional workstations can be added via the Ethernet fiber optic loop in the Control Room, East Electrical Room, Maintenance office, West Electrical Room, and room 322.

WHEELABRATOR McKAY BAY, INC.

Each server and station can control processes by the use of the Conductor NT software operating on personal computer hardware platform under the Windows 2000 Professional Operating System environment. Using interactive process graphics the plant operator can monitor and control all analog loops and digital devices interfaced to the network.

All process alarms, history, and various logs are input to the printer server located in the control room. One printer (dot matrix) is dedicated to the recording of system events like alarms and input/output changes in real time as they occur in the DCS. The other two printers are used for the printing of system logs and graphic displays.

The primary operating mode is through the graphic displays, which provide the operator with a pictorial view of the process. The process is broken down into many separate displays to control the entire operation. Each graphic display gives the operator access to every control loop and function shown on that particular display, setting of controller set points, starting or stopping of motors, alarm indications, and process data. In addition, there are group displays showing all four units for boiler and SDA controls and are used as the primary graphic source to operate the boilers.

In a typical operation input from an operator in the control room: A window on the Conductor NT software is open giving access to the process. When a signal is given, it travels through the Ethernet network in the control room to CON 1 (the network server). This data is collected and is transmitted through the Infi Net Data Highway coax cable to the various PCUs in the loop. The PCUs operate the various motors and valve controllers in the system.

The process can also be controlled by using a roaming computer (CON6). This computer is typically a notebook computer with an Ethernet port. The roaming computer interfaces the network via the various Ethernet Jacks in the system. When CON 6 is used the signal travels to an Ethernet box and then is converted to a light signal to the fiber optic loop. From there, it travels to the control room where it converted back to the Ethernet loop and into CON1 to the INFI Net Data Highway.



WHEELABRATOR McKAY BAY, INC.

The major components/subsystems that must be placed into service for the Distributed control System are:

- A. Electrical Distribution System

**2.0 SYSTEM STARTUP**

**2.1 Pre-operational Instructions**

**2.1.1 Prerequisites**

- A. Electrical Distribution System in Service (OP-14).

**2.1.2 Precautions and Limitations**

- A. Use proper precautions when working around electrical equipment.
- B. Keep cabinet ventilation louvers clear for cooling.
- C. AC system must be maintained for computer system cooling.

**2.1.3 Pre-Start Checklist**

- A. All permits are released, tags are removed, and equipment is in a safe condition for operation.
- B. Power is available to the DCS from the uninterruptable power supply (UPS) through the Electrical Distribution System.
- C. All fire protection systems are operational.

**2.2 System Startup Instructions**

**2.2.1 Milestones**

1. Distributed control System Startup (Section 2.2.2)

WHEELABRATOR MCKAY BAY, INC.

**2.2.2 Distributed control System Startup**

Action	Location	Verification
1. VERIFY power to the DCS through the uninterruptable power supply (UPS).	Local/ Control Room	All computers boot and the Conductor NT software starts running on CON 1--CON 6.

**When power is supplied to the networks computers and PCU cabinets, all computers will boot up and system will start automatically.**

**3.0 SYSTEM NORMAL OPERATION**

**3.1 Normal Operation**

Action	Location	Verification
1. VERIFY printer operation during alarms. Check paper supply.	Control Room	
2. VERIFY all process alarms		
3. LOG any unusual occurrences		

**4.0 SYSTEM SHUTDOWN**

**4.1 Distributed control System Shutdown**

**NOTE: The DCS system should NEVER be shutdown. The only time it can be shutdown is if the plant is going to cold iron shutdown and all AC power is secured (OP-14)**

Action	Location	Verification
1. SHUTDOWN Electrical Distribution System per OP-14 section 4.2		When power decays in UPS cabinets computers will automatically shutdown.

WHEELABRATOR McKAY BAY, INC.

**5.0 ALARM RESPONSES**

**5.1 Summary of Alarms**

**CONTROL ROOM ALARMS ON DCS FOR DCS**

1. Module Status Alarm

WHEELABRATOR McKAY BAY, INC.

**15-1**

**ALARM RESPONSE**

**NUMBER LIP1M2-LIP15M4**

Alarm Title: MODULE STATUS ALARM

Initiating Device: DCS PROCESS MODULE LIP1M2-LIP15M4

Set point: \_\_\_\_\_ Reset : \_\_\_\_\_

A. <u>Possible Cause(s) of Alarm</u>	
1.	Loss of power to a PCU cabinet
2.	Loss of communication on the Data Highway
B. <u>Consequences</u>	
1.	PCU backup takes over operation
2.	If backup does not operate. Processes controlled by the PCU will not operate or send data.
C.	<u>Immediate Operator Action Control Room</u>
C.	<u>Immediate Operator Action Outside Operator</u>
1.	VERIFY alarm on DCS.
2.	NOTIFY E & I about alarm
D. <u>Follow-up Operator Action</u>	
1.	Notify Shift Supervisor.

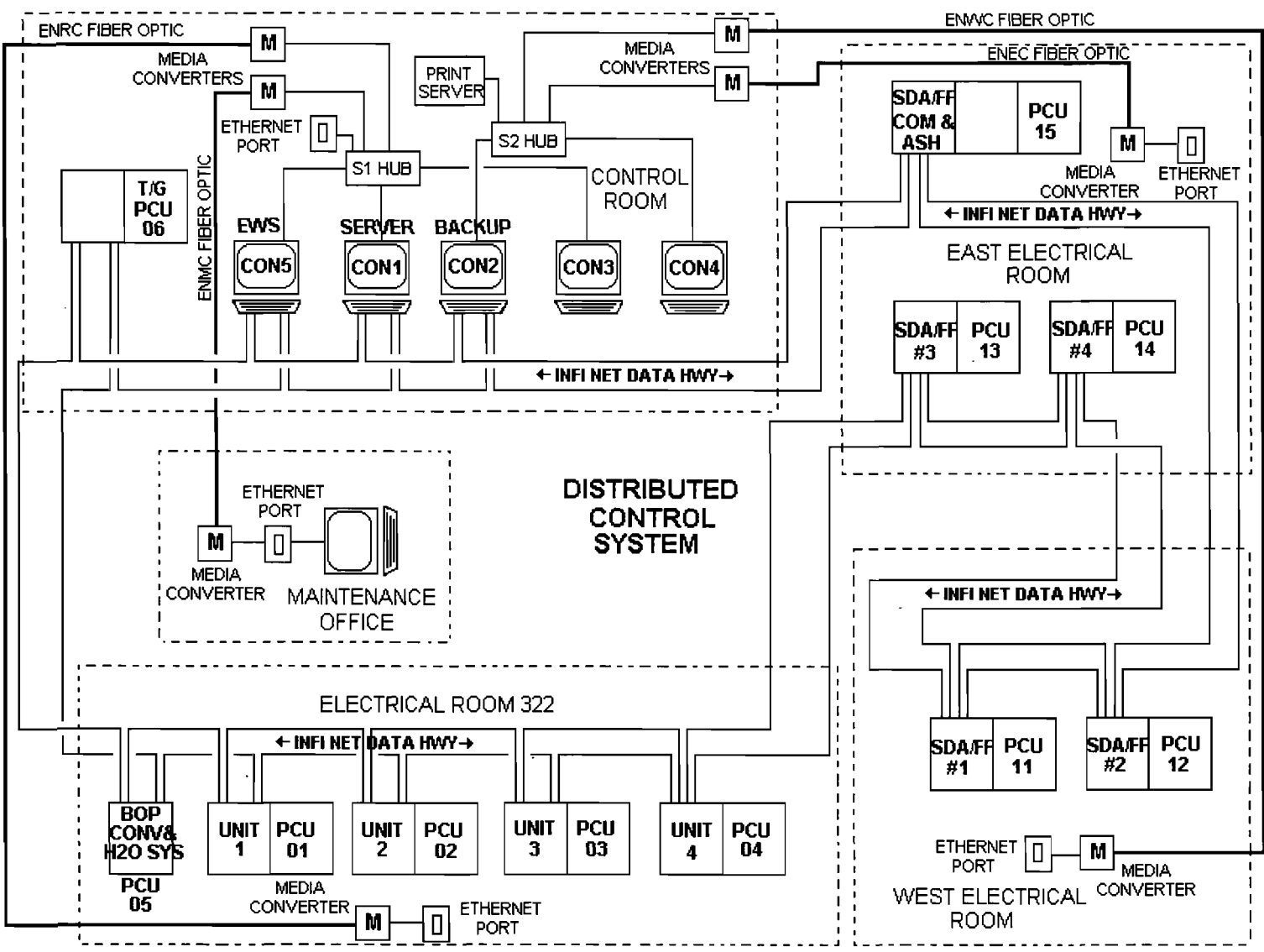

WHEELABRATOR MCKAY BAY, INC.

Operating Procedure No. 15  
 Distributed Control System  
 Date: April 5, 2010  
 Revision 2



**City of Tampa**  
**McKay Bay Refuse-to-Energy Facility**  
**Title V Permit Renewal Application**

---

## **Appendix D**

# **Statement of Compliance & Annual Stack Test Summary**

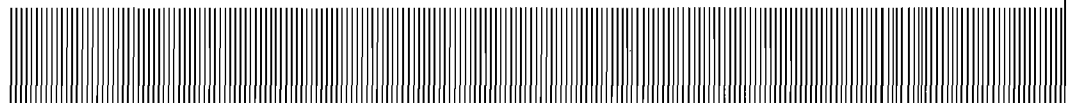



# CITY OF TAMPA

Pam Iorio, Mayor

Department of Solid Waste & Environmental Program Management

Tonja M. Brickhouse, Director

January 15, 2010

Mr. Sterlin Woodard  
Environmental Protection Commission of Hillsborough County  
The Roger P. Stewart Complex  
Air Management Division  
3629 Queen Palm Drive  
Tampa, Florida 33619

RE: Permit No. 0570127-005-AV  
Annual Statement of Compliance

Dear Mr. Woodard:

In compliance with the subject permit requirements; we have attached DEP Form No. 62-213.900(7), Statement of Compliance – Title V Source. Additional support documentation is maintained at the Facility and available for your review if necessary.

By copy of this letter, we are sending the Statement to U.S. EPA Region 4.

I, the undersigned, am the responsible official and certify based on information and belief formed after reasonable inquiry, the statements and information in the document are true, accurate, and complete.

If you have any questions regarding this information, please contact Mr. Greig Grotecloss of the City of Tampa or Mr. Bill Hooper, EHS Manager, Wheelabrator McKay Bay.

Sincerely,

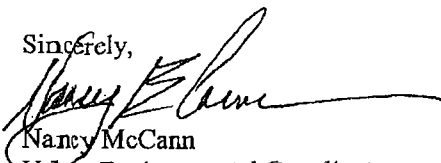

Nancy McCann  
Urban Environmental Coordinator

Attachment

cc: U. S. EPA Region 4, Air and EPCRA Enforcement Branch  
Mr. Max Grondhal - FDEP  
Bill Hooper  
Howard McKnight  
Tim Porter  
Pat Patton  
Tamara Stankunas  
Greig Grotecloss

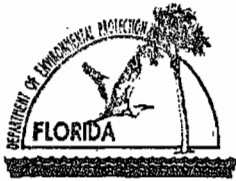

# Department of Environmental Protection

## Division of Air Resource Management

### STATEMENT OF COMPLIANCE - TITLE V SOURCE

REASON FOR SUBMISSION (Check one to indicate why this statement of compliance is being submitted)

<input checked="" type="checkbox"/> Annual Requirement	<input type="checkbox"/> Transfer of Permit	<input type="checkbox"/> Permanent Facility Shutdown
--	---	--

REPORTING PERIOD*	REPORT DEADLINE**
January 1, 2009 through December 31 of 2009 (year)	March 1, 2010

\*The statement of compliance must cover all conditions that were in effect during the indicated reporting period, including any conditions that were added, deleted, or changed through permit revision.

\*\*See Rule 62-213.440(3)(a)2., F.A.C.

Facility Owner/Company Name: City of Tampa

Site Name: McKay Bay Facility

Facility ID No. 0570127

County: Hillborough

#### COMPLIANCE STATEMENT (Check only one of the following three options)

A. This facility was in compliance with all terms and conditions of the Title V Air Operation Permit and, if applicable, the Acid Rain Part, and there were no reportable incidents of deviations from applicable requirements associated with any malfunction or breakdown of process, fuel burning or emission control equipment, or monitoring systems during the reporting period identified above.

B. This facility was in compliance with all terms and conditions of the Title V Air Operation Permit and, if applicable, the Acid Rain Part; however, there were one or more reportable incidents of deviations from applicable requirements associated with malfunctions or breakdowns of process, fuel burning or emission control equipment, or monitoring systems during the reporting period identified above, which were reported to the Department. For each incident of deviation, the following information is included:

1. Date of report previously submitted identifying the incident of deviation.
2. Description of the incident.

C. This facility was in compliance with all terms and conditions of the Title V Air Operation Permit and, if applicable, the Acid Rain Part, EXCEPT those identified in the pages attached to this report and any reportable incidents of deviations from applicable requirements associated with malfunctions or breakdowns of process, fuel burning or emission control equipment, or monitoring systems during the reporting period identified above, which were reported to the Department. For each item of noncompliance, the following information is included:

1. Emissions unit identification number.
2. Specific permit condition number (note whether the permit condition has been added, deleted, or changed during certification period).
3. Description of the requirement of the permit condition.
4. Basis for the determination of noncompliance (for monitored parameters, indicate whether monitoring was continuous, i.e., recorded at least every 15 minutes, or intermittent).
5. Beginning and ending dates of periods of noncompliance.
6. Identification of the probable cause of noncompliance and description of corrective action or preventative measures implemented.
7. Dates of any reports previously submitted identifying this incident of noncompliance.

For each incident of deviation, as described in paragraph B. above, the following information is included:

1. Date of report previously submitted identifying the incident of deviation.
2. Description of the incident.



# STATEMENT OF COMPLIANCE - TITLE V SOURCE

## RESPONSIBLE OFFICIAL CERTIFICATION

I, the undersigned, am a responsible official (Title V air permit application or responsible official notification form on file with the Department) of the Title V source for which this document is being submitted. With respect to all matters other than Acid Rain program requirements, I hereby certify, based on the information and belief formed after reasonable inquiry, that the statements made and data contained in this document are true, accurate, and complete.

Nancy E. Carr 1/11/10  
(Signature of Title V Source Responsible Official) (Date)

Name: Nancy McCann Title: Urban Environmental Coordinator

## DESIGNATED REPRESENTATIVE CERTIFICATION (only applicable to Acid Rain source)

I, the undersigned, am authorized to make this submission on behalf of the owners and operators of the Acid Rain source or Acid Rain units for which the submission is made. I certify under penalty of law that I have personally examined, and am familiar with, the statements and information submitted in this document and all its attachments. Based on my inquiry of those individuals with primary responsibility for obtaining the information, I certify that the statements and information are to the best of my knowledge and belief true, accurate, and complete. I am aware that there are significant penalties for submitting false statements and information or omitting required statements and information, including the possibility of fine or imprisonment.

\_\_\_\_\_  
(Signature of Acid Rain Source Designated Representative) (Date)

Name: \_\_\_\_\_ Title: \_\_\_\_\_

*{Note: Attachments, if required, are created by a responsible official or designated representative, as appropriate, and should consist of the information specified and any supporting records. Additional information may also be attached by a responsible official or designated representative when elaboration is required for clarity. This report is to be submitted to both the compliance authority (DEP district or local air program) and the U.S. Environmental Protection Agency(EPA) (U.S. EPA Region 4, Air and EPCRA Enforcement Branch, 61 Forsyth Street, Atlanta GA 30303).}*

Statement of Compliance  
Title V Source  
Permit No. 050127-005-AV  
2009

The Facility has reported all incidents of deviations from applicable requirements associated with malfunctions or breakdowns of process, fuel burning, emission control equipment, or monitoring systems during the reporting period to the Florida Department of Environmental Protection and the Hillsborough County Environmental Protection Commission in the following documents:

First Quarter 2009 Quarterly Excess Emissions Report dated April 17, 2009  
Second Quarter 2009 Quarterly Excess Emissions Report dated July 17, 2009  
Third Quarter 2009 Quarterly Excess Emissions Report dated October 22, 2009  
Fourth Quarter 2009 Quarterly Excess Emissions Report dated January 15, 2010  
2009 Annual/semi-annual Report dated July 17, 2009  
2009 Annual/semi-annual Report dated January 15, 2010  
Annual Stack Test Report dated November 17, 2009

WHEELABRATOR MCKAY BAY, INC.  
TAMPA, FL

Client Reference No: 13900976  
CleanAir Project No: 10867-2

## **PROJECT OVERVIEW**

1-1

### **INTRODUCTION**

Wheelabrator McKay Bay, Inc. (WMBI) operates a refuse-to-energy facility, located in Tampa, Florida. The facility's emission levels are regulated by the Florida Department of Environmental Protection (FLDEP) and the Environmental Protection Commission of Hillsborough County (EPCHC).

WMBI contracted Clean Air Engineering (CleanAir) to perform a yearly compliance test program at the facility, located in Tampa, Florida, for Units 1, 2, 3 and 4. The Lime Silo Fabric Filter vent and both Carbon Silo Fabric Filter vents were observed for Visual Emissions (VE) and the Ash Handling System was observed for fugitive emissions. Testing was conducted in accordance with CleanAir protocol on compliance testing, dated August 19, 2009, and the facility's FLDEP Permit No. 050127-005-AV, dated June 28, 2006, and Florida regulations rule 62-297.310.

All testing was conducted in accordance with the regulations set-forth by the United States Environmental Protection Agency (EPA), the FLDEP and the EPCHC.

### **Key Project Participants**

Individuals responsible for coordinating and conducting the test program were:

B. Hooper – WBMI  
S. Brown – CleanAir

### **Test Program Parameters**

The testing performed at the SDA Inlets, FF Outlets and Ash Handling System from October 6 through 9, 2009, included the following emissions measurements:

- cadmium, lead and mercury;
- PCDDs and PCDFs (Unit 3 only);
- particulate;
- hydrogen chloride;
- fugitive emissions;
- visual emissions (VE).

**PROJECT OVERVIEW**  
**TEST PROGRAM SYNOPSIS**

**Test Schedule**

The on-site schedule followed during the test program is outlined in Table 1-1.

**Table 1-1:**  
**Schedule of Activities**

Run Number	Location	Method	Analyte	Date	Start Time	End Time
1	Unit 4 FF Outlet	USEPA Method 5/29	Particulate/Metals	10/06/09	07:42	10:02
1	Unit 4 SDA Inlet	USEPA Method 29	Mercury	10/06/09	07:42	10:02
1	Unit 2 FF Outlet	Mod. USEPA Method 26A	HCl	10/06/09	07:50	09:11
1	Unit 2 SDA Inlet	Mod. USEPA Method 26A	HCl	10/06/09	07:50	09:11
1	Unit 3 FF Outlet	USEPA Method 23	PCDD/F	10/06/09	08:39	13:14
2	Unit 2 FF Outlet	Mod. USEPA Method 26A	HCl	10/06/09	09:48	10:48
2	Unit 2 SDA Inlet	Mod. USEPA Method 26A	HCl	10/06/09	09:48	10:48
2	Unit 4 FF Outlet	USEPA Method 5/29	Particulate/Metals	10/06/09	10:57	13:22
2	Unit 4 SDA Inlet	USEPA Method 29	Mercury	10/06/09	10:57	13:22
3	Unit 2 FF Outlet	Mod. USEPA Method 26A	HCl	10/06/09	11:22	12:22
3	Unit 2 SDA Inlet	Mod. USEPA Method 26A	HCl	10/06/09	11:22	12:22
1	Unit 1 FF Outlet	Mod. USEPA Method 26A	HCl	10/06/09	13:31	14:31
1	Unit 1 SDA Inlet	Mod. USEPA Method 26A	HCl	10/06/09	13:31	14:31
3	Unit 4 FF Outlet	USEPA Method 5/29	Particulate/Metals	10/06/09	14:13	16:26
3	Unit 4 SDA Inlet	USEPA Method 29	Mercury	10/06/09	14:13	16:26
2	Unit 1 FF Outlet	Mod. USEPA Method 26A	HCl	10/06/09	15:08	16:08
2	Unit 1 SDA Inlet	Mod. USEPA Method 26A	HCl	10/06/09	15:08	16:08
3	Unit 1 FF Outlet	Mod. USEPA Method 26A	HCl	10/06/09	16:41	18:01
3	Unit 1 SDA Inlet	Mod. USEPA Method 26A	HCl	10/06/09	16:41	18:01
2	Unit 3 FF Outlet	USEPA Method 23	PCDD/F	10/07/09	08:11	12:34
1	Unit 1 FF Outlet	USEPA Method 5/29	Particulate/Metals	10/07/09	08:17	10:58
1	Unit 1 SDA Inlet	USEPA Method 29	Mercury	10/07/09	08:17	10:58
1	Unit 4 FF Outlet	Mod. USEPA Method 26A	HCl	10/07/09	08:18	09:18
1	Unit 4 SDA Inlet	Mod. USEPA Method 26A	HCl	10/07/09	08:18	09:18
2	Unit 4 FF Outlet	Mod. USEPA Method 26A	HCl	10/07/09	09:57	10:57
2	Unit 4 SDA Inlet	Mod. USEPA Method 26A	HCl	10/07/09	09:57	10:57
3	Unit 4 FF Outlet	Mod. USEPA Method 26A	HCl	10/07/09	11:46	12:46
3	Unit 4 SDA Inlet	Mod. USEPA Method 26A	HCl	10/07/09	11:46	12:46
2	Unit 1 FF Outlet	USEPA Method 5/29	Particulate/Metals	10/07/09	12:00	14:21
2	Unit 1 SDA Inlet	USEPA Method 29	Mercury	10/07/09	12:00	14:21
3	Unit 3 FF Outlet	USEPA Method 23	PCDD/F	10/07/09	13:11	17:20
3	Unit 1 FF Outlet	USEPA Method 5/29	Particulate/Metals	10/07/09	15:02	17:15
3	Unit 1 SDA Inlet	USEPA Method 29	Mercury	10/07/09	15:02	17:15
1	Unit 3 FF Outlet	Mod. USEPA Method 26A	HCl	10/08/09	07:43	08:43
1	Unit 3 SDA Inlet	Mod. USEPA Method 26A	HCl	10/08/09	07:43	08:43
1	Unit 2 SDA Inlet	USEPA Method 29	Mercury	10/08/09	08:10	10:37
2	Unit 3 FF Outlet	Mod. USEPA Method 26A	HCl	10/08/09	09:14	10:14
2	Unit 3 SDA Inlet	Mod. USEPA Method 26A	HCl	10/08/09	09:14	10:14
3	Unit 3 FF Outlet	Mod. USEPA Method 26A	HCl	10/08/09	10:43	11:48
3	Unit 3 SDA Inlet	Mod. USEPA Method 26A	HCl	10/08/09	10:43	11:48
2	Unit 2 SDA Inlet	USEPA Method 29	Mercury	10/08/09	11:22	14:26
3	Unit 2 SDA Inlet	USEPA Method 29	Mercury	10/08/09	15:14	17:28
1	Unit 3 FF Outlet	USEPA Method 5/29	Particulate/Metals	10/09/09	07:53	10:17
1	Unit 3 SDA Inlet	USEPA Method 29	Mercury	10/09/09	07:53	10:19
2	Unit 3 FF Outlet	USEPA Method 5/29	Particulate/Metals	10/09/09	11:54	14:09
2	Unit 3 SDA Inlet	USEPA Method 29	Mercury	10/09/09	11:54	14:09
3	Unit 3 FF Outlet	USEPA Method 5/29	Particulate/Metals	10/09/09	14:39	17:06
3	Unit 3 SDA Inlet	USEPA Method 29	Mercury	10/09/09	14:39	17:06

WHEELABRATOR MCKAY BAY, INC.  
TAMPA, FL

Client Reference No: 13900976  
CleanAir Project No: 10867-2

**PROJECT OVERVIEW**  
**TEST PROGRAM SYNOPSIS (CONTINUED)**

1-3

**Results Summary**

Table 1-2 summarizes the results of the test program. A more detailed presentation of the test conditions and results of analysis are shown in Tables 2-1 through 2-26 on pages 2-1 through 2-25.

**Table 1-2:**  
**Summary of Test Results – Units 1 and 2**

<u>Source</u>	<u>Average Unit 1</u>	<u>Average Unit 2</u>	<u>Permit Limit<sup>1</sup></u>
<u>Constituent</u>			
Particulate (mg/dscm @7% O <sub>2</sub> )	1.2	1.6	27
Particulate (lb/hr)	0.11	0.13	2.76
Particulate (lb/MMBtu) <sup>2</sup>	0.0011	0.0014	0.0230
Visual Emissions (% by COMS)	1.2	1.2	10
Cadmium (mg/dscm @ 7% O <sub>2</sub> )	<0.00013	<0.00011	0.040
Cadmium (lb/hr)	<1.10E-05	<8.97E-06	4.10E-01
Cadmium (lb/MMBtu) <sup>2</sup>	<1.14E-07	<9.68E-08	3.42E-05
Lead (mg/dscm @ 7% O <sub>2</sub> )	0.0011	0.00054	0.44
Lead (lb/hr)	0.000092	0.000045	0.0451
Lead (lb/MMBtu) <sup>2</sup>	9.60E-07	4.84E-07	3.76E-04
Mercury (mg/dscm @ 7% O <sub>2</sub> ) <u>or</u> Mercury Removal (%) <sup>3, 4</sup>	0.0017 98%	0.0019 97%	0.070 >85
Hydrogen Chloride (ppmdv @ 7% O <sub>2</sub> ) <u>or</u> Hydrogen Chloride Removal (%) <sup>3, 5</sup>	3.0 99%	9.0 99%	29 >95
Average Combustor Load (Klbs/hr) <sup>6</sup>	61.7	60.9	NA
Average Demonstrated Particulate Control Device Inlet Temperature (°F) <sup>6</sup>	315	315	NA
Average Carbon Feed Rate (lbs/hr) <sup>6</sup>	3.0	3.1	NA

<sup>1</sup> Limits obtained from 40 Code of Federal Register part 60 Subpart Cb - Emission Guidelines and Compliance Times for Large Municipal Waste Combustors That Are Constructed on or Before September 20, 1994 published in Federal Register as 62 FR 45123 on December 19, 1995 as modified on August 25, 1997, Florida's Rule 62-296.416, F.A.C. and FDEP Permit 050127-001-AV dated July 19, 2001.

<sup>2</sup> All lb/MMBtu calculations used Fd of 9,570 for MSW as per Method 19.

<sup>3</sup> Removal for mercury and hydrogen chloride calculated in the unit of their standards.

<sup>4</sup> Mercury limit is 0.070 mg/dscm @ 7% O<sub>2</sub> or 85% removal, whichever is less stringent.

<sup>5</sup> Hydrogen Chloride limit is 29 ppmdv @ 7% O<sub>2</sub> or 95% removal, whichever is less stringent.

<sup>6</sup> Average from all test runs performed on that unit.

**PROJECT OVERVIEW**  
**TEST PROGRAM SYNOPSIS (CONTINUED)**

1-4

Table 1-3:  
Summary of Test Results – Units 3 and 4

Source	Average Unit 3	Average Unit 4	Permit Limit <sup>1</sup>
<b>Constituent</b>			
Particulate (mg/dscm @7% O <sub>2</sub> )	3.0	1.2	27
Particulate (lb/hr)	0.26	0.11	2.76
Particulate (lb/MMBtu) <sup>2</sup>	0.0027	0.0011	0.0230
Visual Emissions (% by COMS)	1.7	2.4	10
Cadmium (mg/dscm @ 7% O <sub>2</sub> )	<0.000093	<0.000102	0.040
Cadmium (lb/hr)	<8.15E-06	<9.01E-06	4.10E-01
Cadmium (lb/MMBtu) <sup>2</sup>	<8.37E-08	<9.20E-08	3.42E-05
Lead (mg/dscm @ 7% O <sub>2</sub> )	0.00043	0.0009	0.44
Lead (lb/hr)	0.000037	0.000078	0.0451
Lead (lb/MMBtu) <sup>2</sup>	3.85E-07	7.87E-07	3.76E-04
Mercury (mg/dscm @ 7% O <sub>2</sub> ) <u>or</u>	0.0022	0.0016	0.070
Mercury Removal (%) <sup>3, 4</sup>	96%	98%	>85
Total PCCD/PCDF (ng/dscm @ 7% O <sub>2</sub> )	3.1	NA	30
Total PCCD/PCDF (lb/hr)	2.67E-07	NA	3.07E-06
Total PCCD/PCDF (lb/MMBtu) <sup>2</sup>	2.59E-11	NA	2.56E-08
Hydrogen Chloride (ppmdv @ 7% O <sub>2</sub> ) <u>or</u>	4.6	4.7	29
Hydrogen Chloride Removal (%) <sup>3, 5</sup>	99%	99%	>95
Average Combustor Load (Klbs/hr) <sup>6</sup>	61.2	61.6	NA
Average Demonstrated Particulate Control Device Inlet Temperature (°F) <sup>6</sup>	315	315	NA
Average Carbon Feed Rate (lbs/hr) <sup>6</sup>	3.0	3.0	NA

<sup>1</sup> Limits obtained from 40 Code of Federal Register part 60 Subpart Cb - Emission Guidelines and Compliance Times for Large Municipal Waste Combustors That Are Constructed on or Before September 20, 1994 published in Federal Register as 62 FR 45123 on December 19, 1995 as modified on August 25, 1997, Florida's Rule 62-296.416, F.A.C. and FDEP Permit 050127-005-AV dated June 28, 2006.

<sup>2</sup> All lb/MMBtu calculations used Fd of 9,570 for MSW as per Method 19.

<sup>3</sup> Removal for mercury and hydrogen chloride calculated in the unit of their standards.

<sup>4</sup> Mercury limit is 0.070 mg/dscm @ 7% O<sub>2</sub> or 85% removal, whichever is less stringent.

<sup>5</sup> Hydrogen Chloride limit is 29 ppmdv @ 7% O<sub>2</sub> or 95% removal, whichever is less stringent.

<sup>6</sup> Average from all test runs performed on that unit.

**PROJECT OVERVIEW**  
**TEST PROGRAM SYNOPSIS (CONTINUED)**

1-5

**Table 1-4:**  
**Subpart Cb – Required Operating Data**

<u>Process Condition</u>	
Unit 1 Maximum Demonstrated Combustor Load (Klbs/hr) <sup>1,4</sup>	62.1
Unit 1 Maximum Particulate Control Device Inlet Temperature (°F) <sup>2,4</sup>	315
Unit 1 Carbon Feed Rate (% output) <sup>3</sup>	12
Unit 1 Carbon Feed Rate (lbs/hr) <sup>3</sup>	3
Unit 2 Maximum Demonstrated Combustor Load (Klbs/hr) <sup>1,5</sup>	61.8
Unit 2 Maximum Particulate Control Device Inlet Temperature (°F) <sup>2,5</sup>	315
Unit 2 Carbon Feed Rate (% output) <sup>3</sup>	15
Unit 2 Carbon Feed Rate (lbs/hr) <sup>3</sup>	3
Unit 3 Maximum Demonstrated Combustor Load (Klbs/hr) <sup>1</sup>	61.4
Unit 3 Maximum Particulate Control Device Inlet Temperature (°F) <sup>2</sup>	315
Unit 3 Carbon Feed Rate (% output) <sup>3</sup>	12
Unit 3 Carbon Feed Rate (lbs/hr) <sup>3</sup>	3
Unit 4 Maximum Demonstrated Combustor Load (Klbs/hr) <sup>1,6</sup>	62.1
Unit 4 Maximum Particulate Control Device Inlet Temperature (°F) <sup>2,6</sup>	315
Unit 4 Carbon Feed Rate (% output) <sup>3</sup>	11
Unit 4 Carbon Feed Rate (lbs/hr) <sup>3</sup>	3

<sup>1</sup> From 40CFR60.58b (i) (8) the maximum demonstrated load during PCDD/PCDF testing, four hour average.

<sup>2</sup> From 40CFR60.58b (i) (9) the highest four hour average during PCDD/PCDF testing.

<sup>3</sup> From 40CFR60.58b (m)(1)(i) an average mass carbon rate during mercury or dioxin testing. The minimum carbon feed rate is established as the lower of the average carbon feed rates measured during the mercury or dioxin testing.

<sup>4</sup> Operating Data from Unit 1 is from CleanAir Cb test report dated November 19, 2007.

<sup>5</sup> Operating Data from Unit 3 is from CleanAir Cb test report dated November 19, 2008.

<sup>6</sup> Operating Data from Unit 4 is from CleanAir Cb test report dated November 10, 2006.

WHEELABRATOR MCKAY BAY, INC.  
TAMPA, FL

Client Reference No: 13900976  
CleanAir Project No: 10867-2

**PROJECT OVERVIEW**  
**TEST PROGRAM SYNOPSIS (CONTINUED)**

1-6

Table 1-5:  
Opacity and Fugitive Emission Results

Source	Constituent	Sampling Method	Results	Permit Limit <sup>1</sup>
<u>Ash Handling System</u> <sup>2</sup>				
	Fugitive Emissions (%)	EPA M22	0	5% of observation time
	Fugitive Emissions (minutes)		0	(<10 minutes)
<u>Lime Silo</u> <sup>3</sup>				
	Visual Emissions (%)	EPA M9	0	5%
<u>Carbon Silo A</u> <sup>3</sup>				
	Visual Emissions (%)	EPA M9	0	5%
<u>Carbon Silo B</u> <sup>3</sup>				
	Visual Emissions (%)	EPA M9	0	5%

<sup>1</sup> Limits obtained from 40 Code of Federal Register part 60 Subpart Cb - Emission Guidelines and Compliance Times for Large Municipal Waste Combustors That Are Constructed on or Before September 20, 1994 published in Federal Register as 62 FR 45123 on December 19, 1995 as modified on August 25, 1997, Florida's Rule 62-296.416, F.A.C. and Title V Permit 050127-005-AV.

<sup>2</sup> The Ash Handling System was observed at various locations for a total of 200 minutes.

<sup>3</sup> The Carbon and Lime Silo's were observed for one hour.

**Discussion of Test Program**

During all compliance testing, the units being tested were operated within 10% of the facility's steam flow set point of 62,186 lbs/hr (the rated capacity). The steam flow for each test is reported in the result tables for each constituent. Bill Hooper of WMBI provided all the process (operating) data. This data is presented in its entirety in Appendix D.

The Subpart Cb operating data is shown in Table 1-5, above.

As allowed by Section 60.38b of Subpart Cb, an alternative performance testing schedule for the facility's PCDDs/PCDFs was followed. Unit 3 was tested during this compliance test series. Unit 4 will be tested next year, Unit 1 the following year and so on.

All equipment utilized for compliance testing was manufactured by CleanAir.



WHEELABRATOR MCKAY BAY, INC.  
TAMPA, FL

Client Reference No: 13900976  
CleanAir Project No: 10867-2

**PROJECT OVERVIEW**

1-7

**TEST PROGRAM SYNOPSIS (CONTINUED)**

The EPCHC questioned the use of a modification to Method 26A, as stated in the test protocol. This modification samples HCl at a single point utilizing a constant sample rate. Tim Porter of Wheelabrator Technologies, Inc. petitioned the FLDEP for use of this methodology for all SDA Inlet and FF Outlet HCl testing. The modification was approved in an e-mail sent by Errin Pichard to all interested parties on September 29, 2009. A copy of this e-mail is presented in Appendix J.

Raina Vicere conducted the VE observations on the Carbon Silos and the Lime Silo. Andy Obuchowski conducted the fugitive emission observations on the Ash Handling System. Ms. Vicere's VE evaluation certificate is presented in Appendix I.

Any fractions of the mercury analysis that were reported as not detected were summed as zero, if there was at least one (1) fraction in that run that was detected. The cadmium and lead front- and back-half fractions were combined proportionately for analysis, per EPA Method 29, Section 5.4. Particulate and mercury/metals analysis was performed by Element One, Inc. in Wilmington, North Carolina.

Field blanks were done for the Method 23 and Method 29 testing by assembling a used set of glassware, taking the complete train to the outlet location and performing a leak-check. These samples were treated exactly as the other samples. The results for the Method 23 and Method 29 field blanks are presented in Table 2-26 on page 2-24, as well as in Appendix H.

All Method 23 samples were analyzed with the DB-5S column with modified calibration and additional quality assurance procedures as a direct substitute for the DB-5 and DB-225 columns. Confirmation of the 2,3,7,8 TCDF and TCDD 2,3,7,8 isomers was performed on the DB-5S column. The DB-5S column and modified calibration procedures meets the column separation requirement and can be used as a direct substitute for the DB-5 and DB-225 columns, in accordance with Method 23 as approved by the EPA. All QA/QC data (spikes and recoveries) are presented in Appendix G.

Sample rinses utilized acetone and toluene only. The methylene chloride rinse was omitted as specified in the 2009 protocol, per the letter presented in Appendix J of this report. Analytical Perspectives of Wilmington, North Carolina, performed the PCDD/PCDF analysis.

**PROJECT OVERVIEW**

1-8

**TEST PROGRAM SYNOPSIS (CONTINUED)**

The Method 23 results for Runs 1 and 2 contained at least one (1) estimated maximum possible concentration (EMPC) value. EMPC results do not meet all the identification criteria required by Method 23 to be positively identified as a dioxin or furan. Specifically, the integrated ion abundance ratios were not within 15% of the theoretical value limits specified in Method 23, Section 5.3.2.5, Table 4.

The laboratory reports EMPC results as zero. For this reason, all EMPC results are enclosed in brackets and are considered zero when calculating total dioxins/furans. All of the runs also contained one (1) value that was below the detection limit. For analytical results that are below the detection limit, values are reported as non-detect (ND), with the detection limit in parenthesis and are considered zero for calculating total catch weights, per Method 23, Section 9.9.

All test methods were done in triplicate. All data that is reported in the units of lb/MMBtu utilized the Fd value of 9,570, as per EPA Method 19. A normal soot blow was done during the Run 2 particulate test on Units 1, 2 and 4, and during Run 3 on Unit 3.

The Unit 3 SDA Inlet modified Method 26A integrated gas sample (IGS) bag was found to have a hole in it after the run was completed. The oxygen (O<sub>2</sub>) and carbon dioxide (CO<sub>2</sub>) analysis of the bag proved to be unusable; therefore, an average of Runs 1 and 3 was used for O<sub>2</sub>/CO<sub>2</sub> data for that test run.

A representative of the EPCHC observed that the first port traversed remained uncovered during the rest of the Unit 2 FF Outlet Method 5/29 test run. The moisture, O<sub>2</sub>/CO<sub>2</sub>, as well as the metals/mercury results from this run, shows that this had no effect on the final results.

---

*End of Section 1 – Project Overview*