

**BIG BEND STATION  
UNITS 1 AND 2  
FLUE GAS DESULFURIZATION SYSTEM  
AIR CONSTRUCTION PERMIT APPLICATION**

Prepared for:



Prepared by:

***ECT***

*Environmental Consulting & Technology, Inc.*

*3701 Northwest 98<sup>th</sup> Street  
Gainesville, Florida 32606*

**ECT No. 98102-0200**

**July 1998**

**Revision 1, 07/20/98**

**RECEIVED**

JUL 21 1998

BUREAU OF  
AIR REGULATION

**BIG BEND STATION  
UNITS 1 AND 2  
FLUE GAS DESULFURIZATION SYSTEM  
AIR CONSTRUCTION PERMIT APPLICATION**

Prepared for:



Prepared by:

***ECT***

*Environmental Consulting & Technology, Inc.*

*3701 Northwest 98<sup>th</sup> Street  
Gainesville, Florida 32606*

**ECT No. 98102-0200**

**July 1998**

**Revision 1, 07/20/98**



TAMPA ELECTRIC

July 20, 1998

Mr. Clair Fancy  
Florida Department of Environmental Protection  
Bureau of Air Regulation  
111 Magnolia Drive, Suite 4  
Tallahassee, Florida 32301

Via FedEx  
Airbill No. 805858540866

Re: Tampa Electric Company  
Big Bend Station Units 1 and 2  
Flue Gas Desulfurization (FGD) System  
Construction Permit Application - Revision 1

Dear Mr. Fancy:

Please find enclosed three (3) signed and sealed Electronic Submission of Application (ELSA) copies of Tampa Electric Company's (TEC) revised permit application to construct a FGD system to remove sulfur dioxide (SO<sub>2</sub>) from the Big Bend Station Units 1 and 2 gas stream prior to release to the atmosphere. This revision changes the Units 1 and 2 post-scrubber gas stream SO<sub>2</sub> content from approximately 0.6 pounds per million British thermal units (lb/MMBtu) in the original application to 0.82 lb/MMBtu in this revised application. Additional consideration of available coal supplies, scrubber design data, and operational scenarios makes this change necessary to more accurately reflect the potential maximum expected SO<sub>2</sub> emission rate.

The fourth signed and sealed copy of the application is being submitted to the Environmental Protection Commission of Hillsborough County.

TEC appreciates your continued timely review and processing of this construction permit application. If you should have any questions, please feel free to call me at (813) 641-5016.

Sincerely,

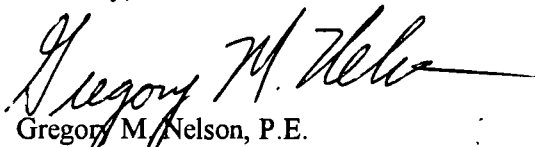
  
Gregory M. Nelson, P.E.  
Manager  
Environmental Planning

EP\gm\GMN111

Enclosures

c/enc: Mr. Joe Kahn, FDEP - Tallahassee  
Mr. Rick Kirby, EPCHC

TAMPA ELECTRIC COMPANY  
P. O. BOX 111 TAMPA, FL 33601-0111

(813) 228-4111

AN EQUAL OPPORTUNITY COMPANY  
HTTP://WWW.TECOENERGY.COM

CUSTOMER SERVICE:  
HILLSBOROUGH COUNTY (813) 223-0800  
OUTSIDE HILLSBOROUGH COUNTY 1 (888) 223-0800

# Signatures

## Owner/Authorized Representative or Responsible Official

1. Name and Title of Owner/Authorized Representative or Responsible Official :

Name : Gregory M. Nelson, P.E.  
Title : Manager - Environmental Planning

2. Owner or Authorized Representative or Responsible Official Mailing Address :

Organization/Firm : Tampa Electric Company  
Street Address : 6944 U.S. Highway 41 North  
City : Apollo Beach  
State : FL Zip Code : 33572-9200

3. Owner/Authorized Representative or Responsible Official Telephone Numbers :

Telephone : (813)641-5016 Fax : (813)641-5081

4. Owner/Authorized Representative or Responsible Official Statement :

*I, the undersigned, am the owner or authorized representative\* of the non-Title V source addressed in this Application for Air Permit or the responsible official, as defined in Rule 62-210.200, F.A.C., of the Title V source addressed in this application, whichever is applicable. I hereby certify, based on information and belief formed after reasonable inquiry, that the statements made in this application are true, accurate and complete and that, to the best of my knowledge, any estimates of emissions reported in this application are based upon reasonable techniques for calculating emissions. The air pollutant emissions units and air pollution control equipment described in this application will be operated and maintained so as to comply with all applicable standards for control of air pollutant emissions found in the statutes of the State of Florida and rules of the Department of Environmental Protection and revisions thereof. I understand that a permit, if granted by the Department, cannot be transferred without authorization from the Department, and I will promptly notify the Department upon sale or legal transfer of any permitted emissions units.*

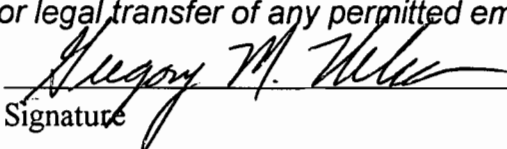
  
Signature

7/17/98  
Date

\* Attach letter of authorization if not currently on file.

I. Part 2 - 1

DEP Form No. 62-210.900(1) - Form  
Effective : 3-21-96

Revision 1, 07/20/98

4. Professional Engineer Statement :

*I, the undersigned, hereby certified, except as particularly noted herein\*, that :*

*(1) To the best of my knowledge, there is reasonable assurance that the air pollutant emissions unit(s) and the air pollutant control equipment described in this Application for Air Permit, when properly operated and maintained, will comply with all applicable standards for control of air pollutant emissions found in the Florida Statutes and rules of the Department of Environmental Protection; and*

*(2) To the best of my knowledge, any emission estimates reported or relied on in this application are true, accurate, and complete and are either based upon reasonable techniques available for calculating emissions or, for emission estimates of hazardous air pollutants not regulated for an emissions unit addressed in this application, based solely upon the materials, information and calculations submitted with this application.*

*If the purpose of this application is to obtain a Title V source air operation permit (check here [ ] if so), I further certify that each emissions unit described in this Application for Air Permit, when properly operated and maintained, will comply with the applicable requirements identified in this application to which the unit is subject, except those emissions units for which a compliance schedule is submitted with this application.*

*If the purpose of this application is to obtain an air construction permit for one or more proposed new or modified emissions units (check here [✓] if so), I further certify that the engineering features of each such emissions unit described in this application have been designed or examined by me or individuals under my direct supervision and found to be in conformity with sound engineering principles applicable to the control of emissions of the air pollutants characterized in this application.*

*If the purpose of this application is to obtain an initial air operation permit or operation permit revision for one or more newly constructed or modified emissions units (check here [ ] if so), I further certify that, with the exception of any changes detailed as part of this application, each such emissions has been constructed or modified in substantial accordance with the information given in the corresponding application for air construction permit and with all provisions contained in such permit.*

*Thomas W. Quinn*  
\_\_\_\_\_  
Signature

*7/20/98*  
\_\_\_\_\_  
Date

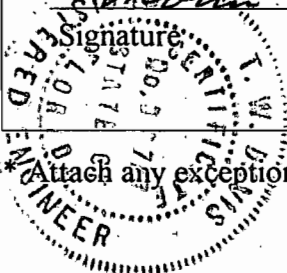

Attach any exception to certification statement.

**DOCUMENT II.E.1**  
**AREA MAP SHOWING FACILITY LOCATION**

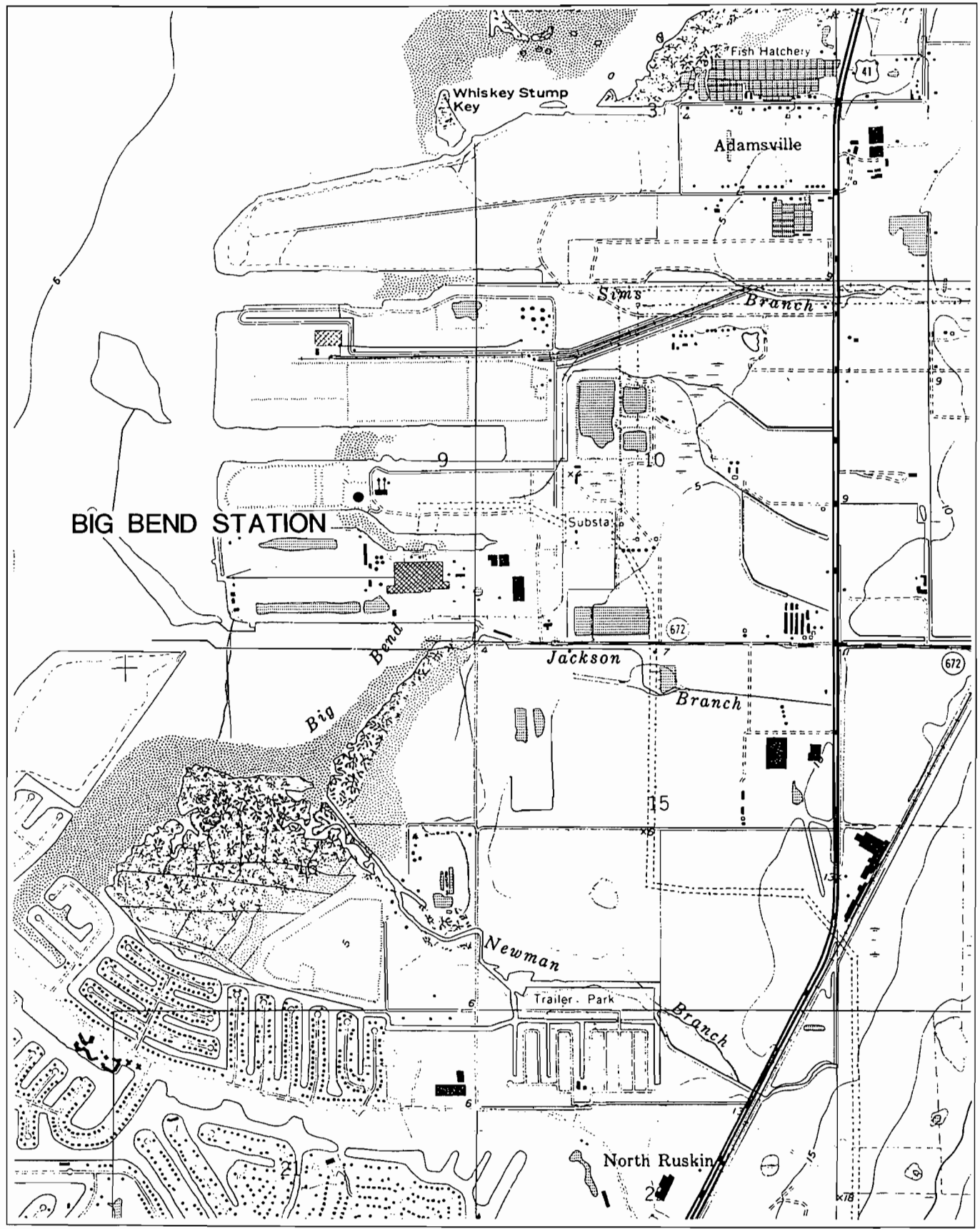

DOCUMENT II.E.1.

**BIG BEND STATION AREA MAP**

Source: USGS Quad, Gibsonton, FL, 1987.

**TECO**

**TAMPA ELECTRIC**

**DOCUMENT II.E.2**  
**FACILITY PLOT PLANS**



Combustion Sources (CS)

Description	Source ID	Figure No.	
		Location	Process
Unit No. 1	CS-001	II.E.2.A	II.E.3.A&B
Unit No. 2	CS-002	II.E.2.A	II.E.3.A&B
Unit No. 3	CS-003	II.E.2.A	II.E.3.A&B
Unit No. 4	CS-004	II.E.2.A	II.E.3.A&B

Limestone Handling and Storage Sources (LSH)

Description	Source ID	Location	Process
Railcar/Truck Unloading	LSH-001	II.E.2.B	II.E.3.C
Conveyor LB to Conveyor LC	LSH-002	II.E.2.B	II.E.3.C
Conveyor LD to Conveyor LE	LSH-003	II.E.2.B	II.E.3.C
Conveyor LE to Conveyor LF and Storage Silo A	LSH-004, 005	II.E.2.B	II.E.3.C
Conveyor LF to Conveyor LG and Storage Silo B	LSH-006, 007	II.E.2.B	II.E.3.C
Conveyor LG to Storage Silo C	LSH-008	II.E.2.B	II.E.3.C
Trucks, Full	LSH-009	II.E.2.B	II.E.3.C
Trucks, Empty	LSH-010	II.E.2.B	II.E.3.C

Gypsum Handling and Storage Sources (GH)

Description	Source ID	Location	Process
Stacker Conveyor to North Stackout Pile	GH-001	II.E.2.D	II.E.3.D
Storage - North Stackout Pile	GH-002	II.E.2.D	II.E.3.D
Dozer Operations on North Stackout Pile	GH-003	II.E.2.D	II.E.3.D
Dozer Transfer from North Stackout Pile to Loadout Conveyor	GH-004a	II.E.2.D	II.E.3.D
Loadout Conveyor to Trucks	GH-004b	II.E.2.D	II.E.3.D
Trucks (Full) at North Stackout Pile to Off-Site	GH-005	II.E.2.D	II.E.3.D
Trucks (Empty) at North Stackout Pile to Off-Site	GH-006	II.E.2.D	II.E.3.D
Conveyor GD to Conveyor GE	GH-007	II.E.2.E	II.E.3.D
Conveyor GE to Conveyor GF	GH-008	II.E.2.E	II.E.3.D
Conveyor GF to Radial Stacker	GH-009	II.E.2.E	II.E.3.D
Radial Stacker to South Stackout Pile	GH-010	II.E.2.E	II.E.3.D
Storage - South Stackout Pile	GH-011	II.E.2.E	II.E.3.D
Dozer Operations on South Stackout Pile	GH-012	II.E.2.E	II.E.3.D
Dozer Operations on Long Term Storage Pile	GH-013	II.E.2.E	II.E.3.D
Storage - Long Term Storage Pile	GH-014	II.E.2.E	II.E.3.D
Dozer Transfer from Long Term Storage Pile to Trucks	GH-015	II.E.2.E	II.E.3.D
Trucks (Full) at Long Term Storage Pile to Off-Site	GH-016	II.E.2.E	II.E.3.D
Trucks (Empty) at Long Term Storage Pile to Off-Site	GH-017	II.E.2.E	II.E.3.D

DOCUMENT II.E.2.A.

BIG BEND STATION EMISSION SOURCE  
IDENTIFICATION KEY SHEET

Source: TEC, 1994; ECT, 1998.



**TECO**  
TAMPA ELECTRIC



NO SCALE

SCALE: 1"=400' (APPROX.)

LEGEND

CS-001b EMISSION POINT

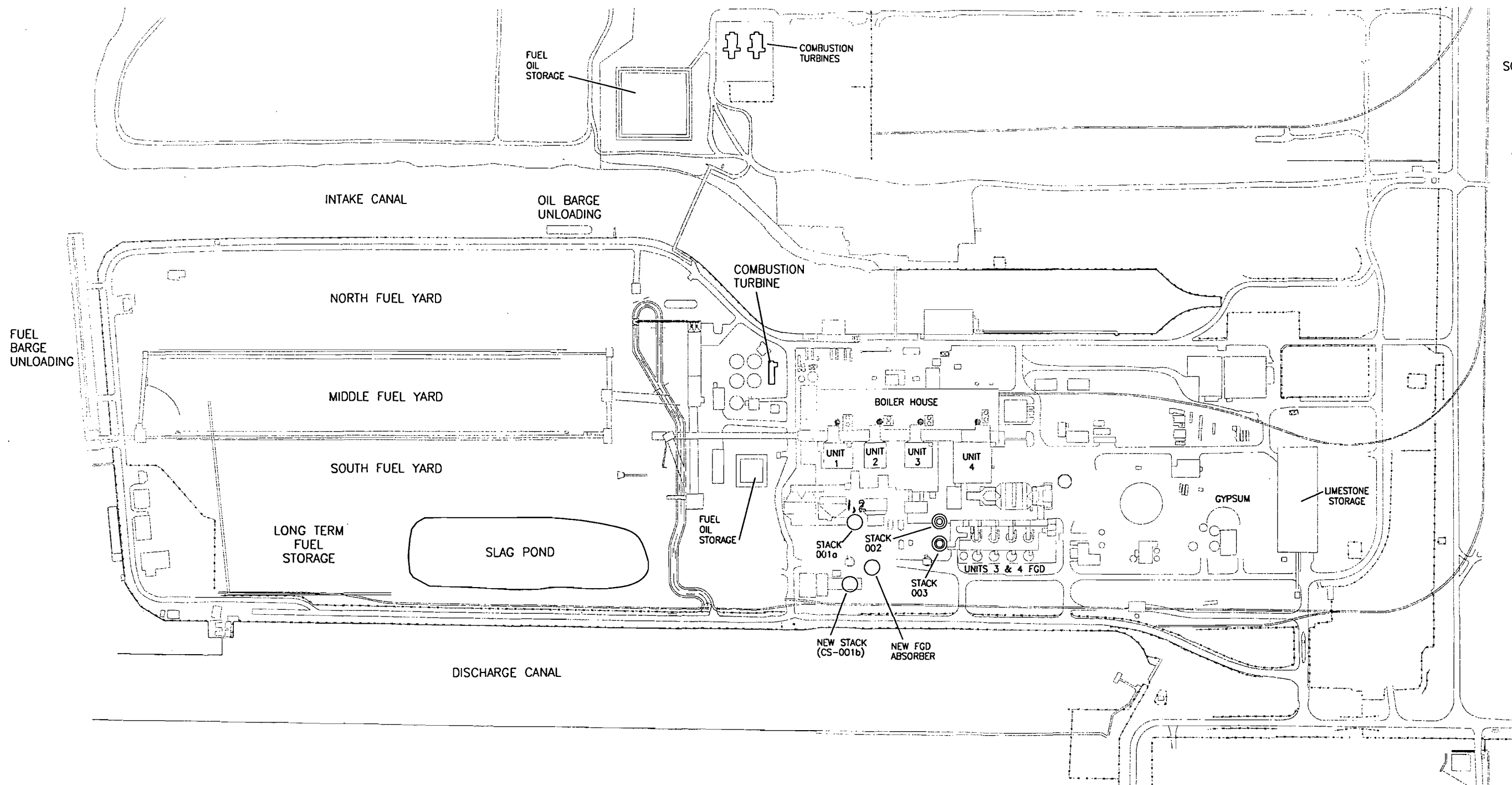

DOCUMENT II.E.2.B.  
COMBUSTION EMISSION SOURCES

Source: ECT, 1998.

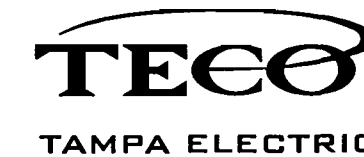



NO SCALE

SCALE: 1"=400' (APPROX.)

LEGEND

LSH-003 EMISSION POINT

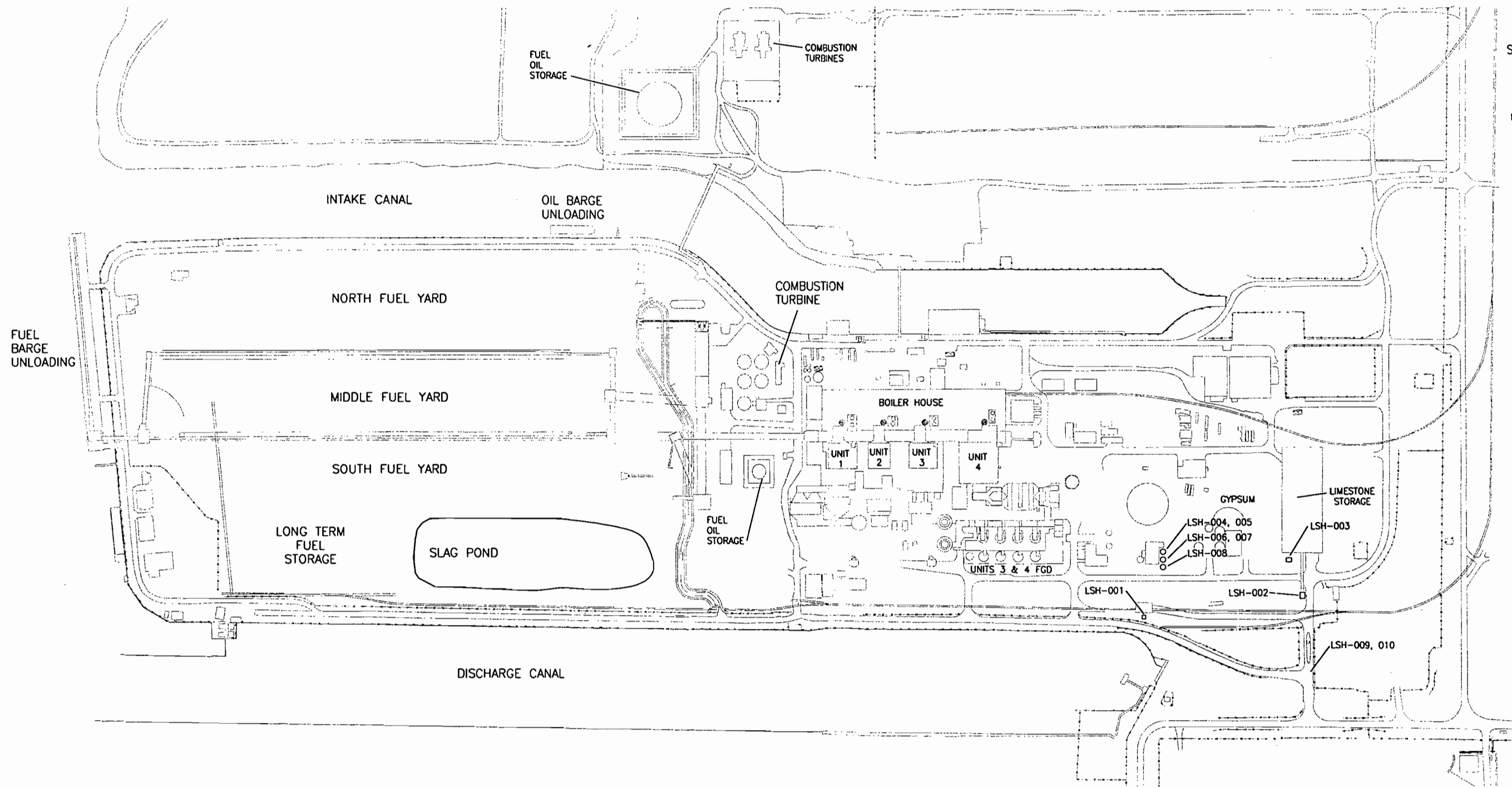

DOCUMENT IIE.2.C.  
LIMESTONE HANDLING EMISSION SOURCES

Source: ECT, 1998.



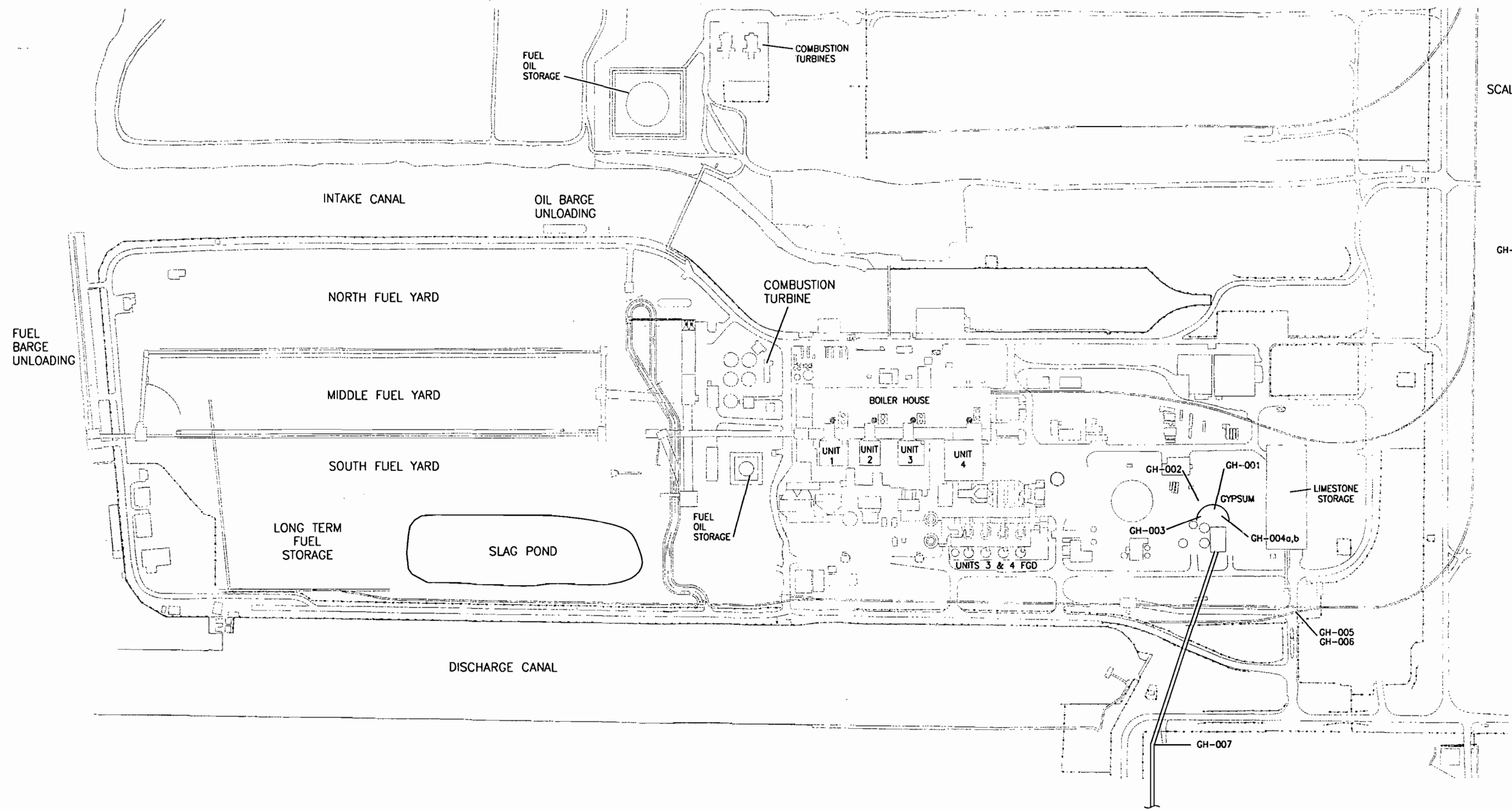

SCALE: 1"=400' (APPROX.)

**LEGEND**

GH-006 EMISSION POINT

DOCUMENT I.I.E.2.D.  
 BIG BEND STATION  
 GYPSUM HANDLING AND STORAGE EMISSION SOURCES  
 Source: ECT, 1998.



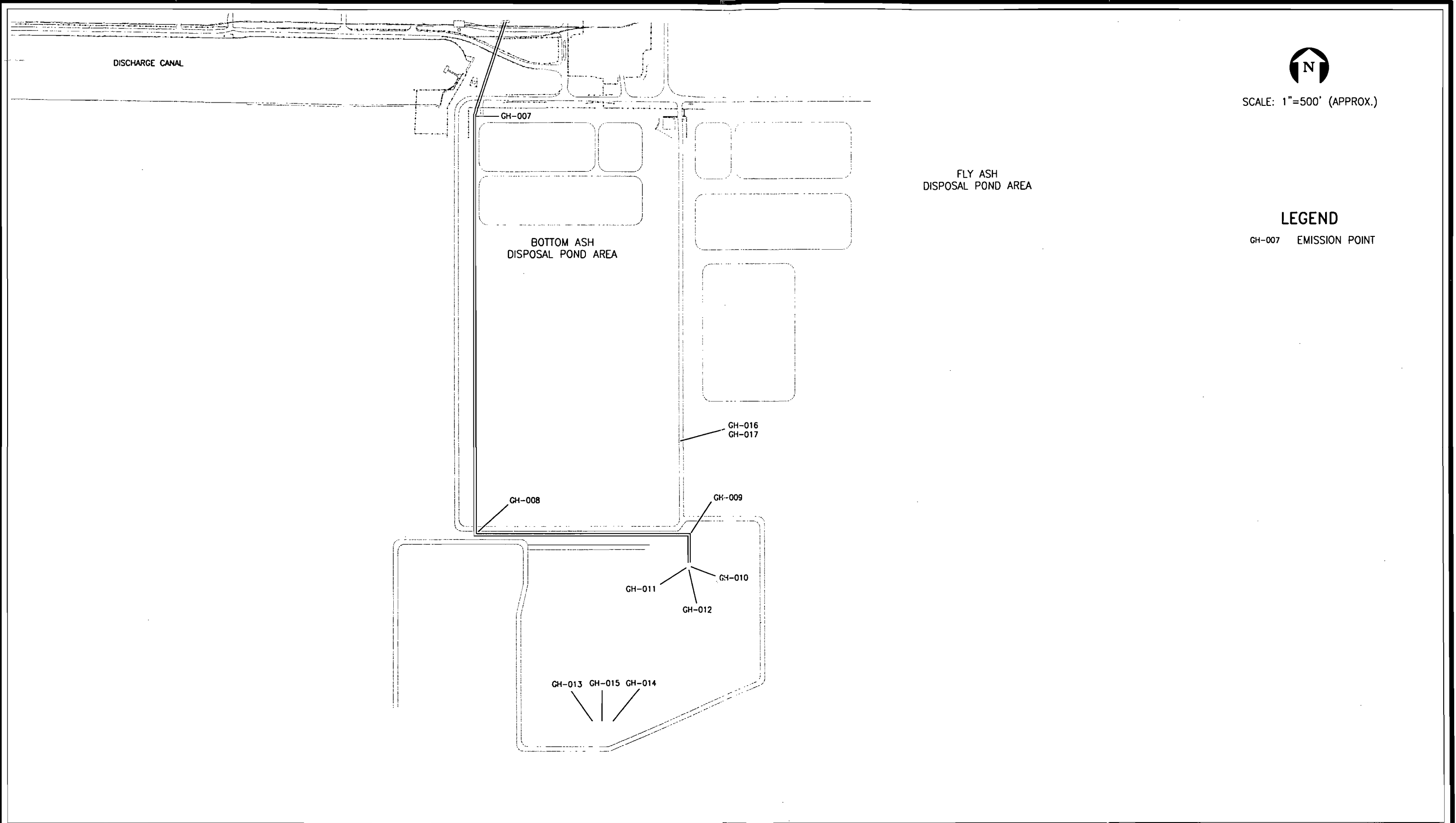

SCALE: 1"=500' (APPROX.)

**LEGEND**

GH-007 EMISSION POINT

DOCUMENT II.E.2.E.

BIG BEND STATION

GYPSUM HANDLING AND STORAGE EMISSION SOURCE

Source: ECT, 1998.



**DOCUMENT II.E.3**  
**PROCESS FLOW DIAGRAMS**

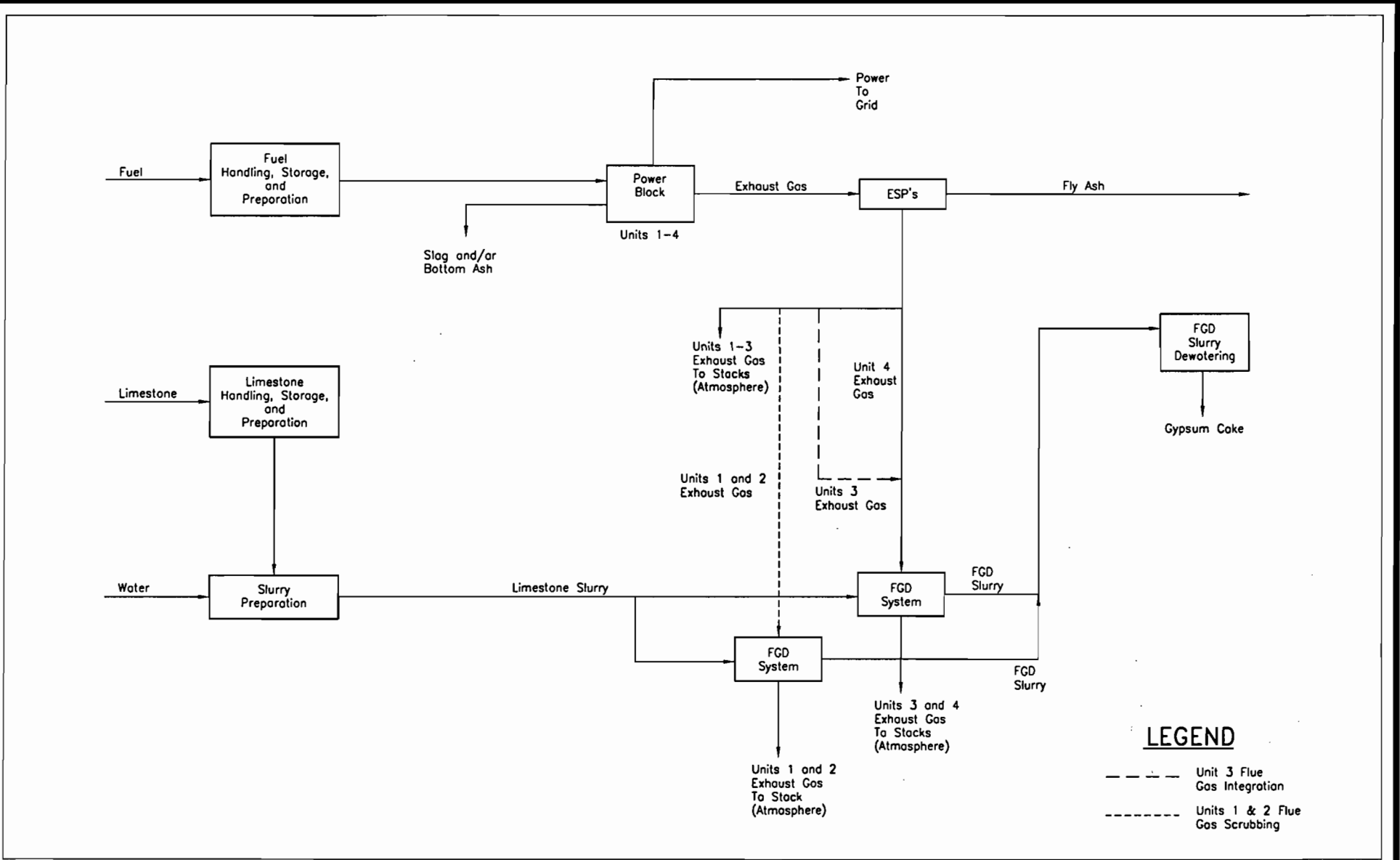



DOCUMENT I.I.E.3.A.  
 OVERALL BOILER PROCESS FLOW DIAGRAM

Source: ECT, 1998.

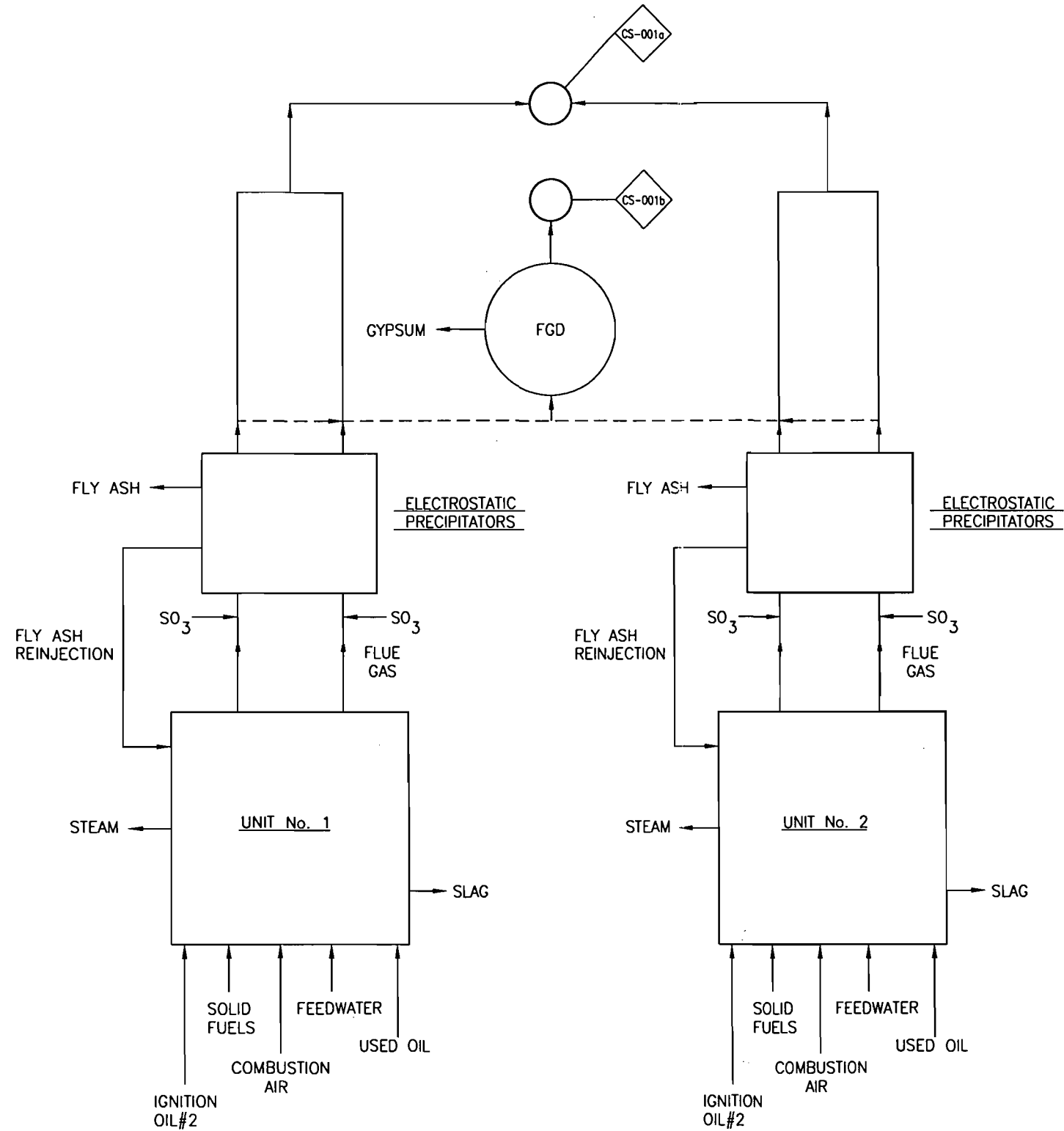



LEGEND

-  EMISSION POINT
-  UNITS 1 & 2 FLUE GAS SCRUBBING

DOCUMENT I.I.E.3.B.  
 BOILER PROCESS FLOW DIAGRAM

Source: ECT, 1998.





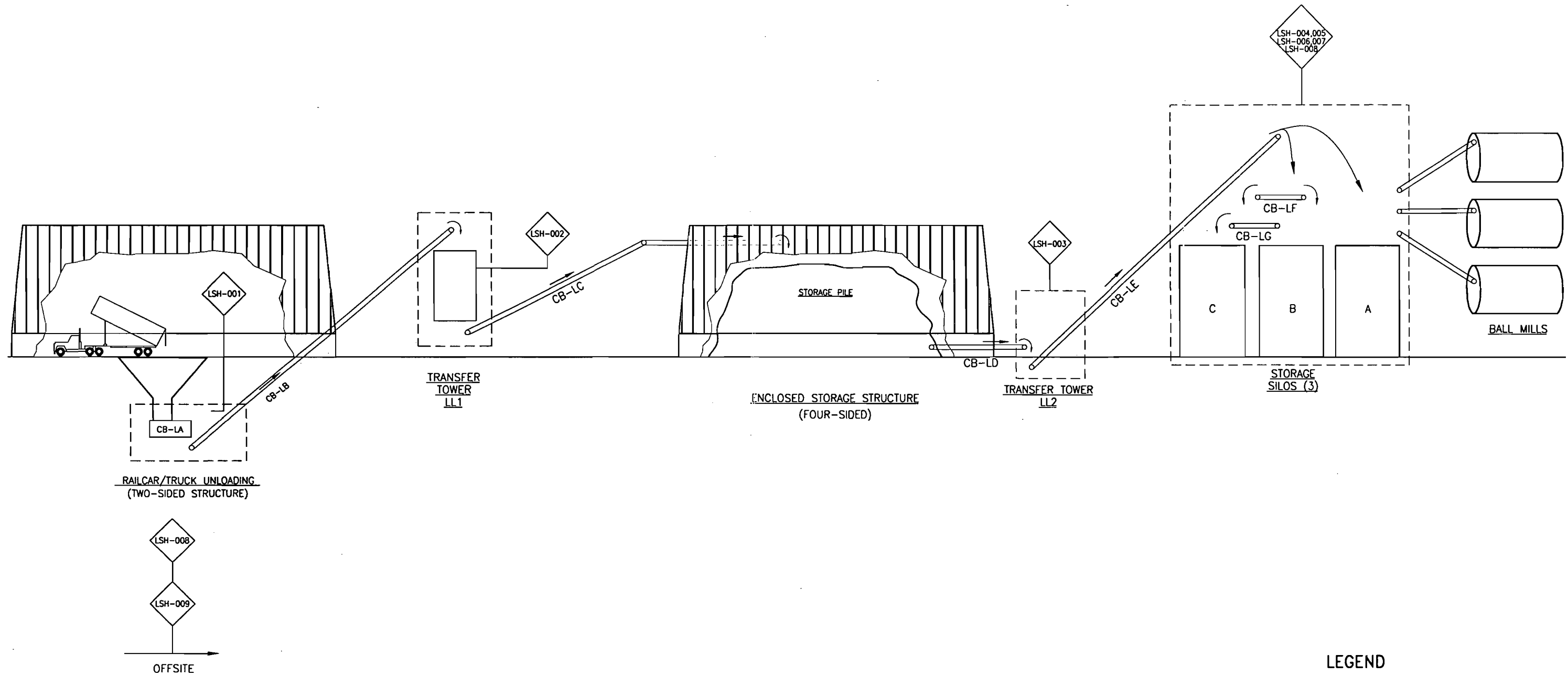

**LEGEND**

◆ LSH-003 EMISSION POINT

DOCUMENT I.I.E.3.C.  
 LIMESTONE HANDLING PROCESS FLOW DIAGRAM

Source: ECT, 1998.



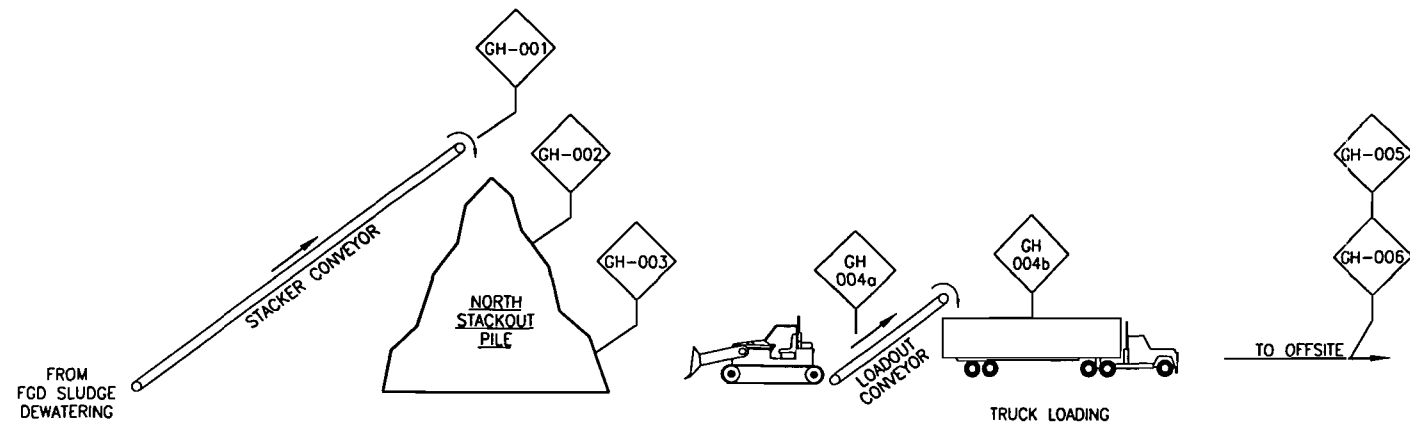

NORTH STACKOUT AREA

LEGEND

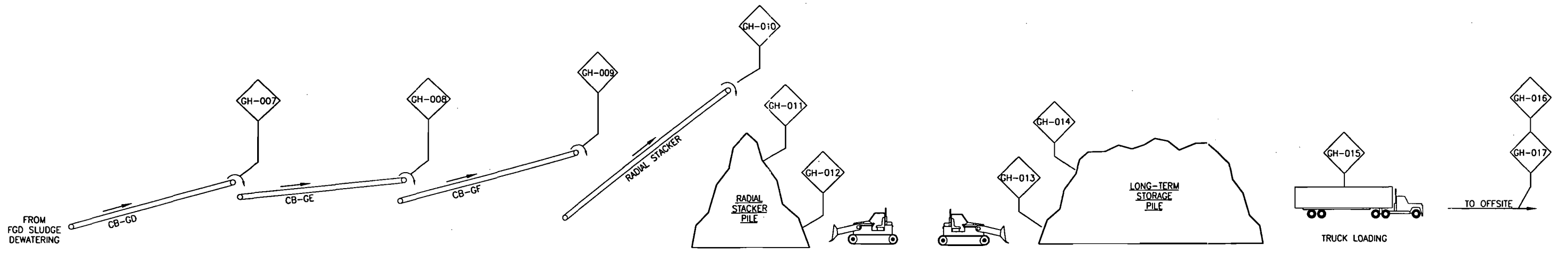

LONG TERM STORAGE AREA

DOCUMENT I.I.E.3.D.  
GYPSUM HANDLING PROCESS FLOW DIAGRAM

Source: ECT, 1998.



**DOCUMENT II.E.4**  
**PRECAUTIONS TO PREVENT EMISSIONS OF**  
**UNCONFINED PARTICULATE MATTER**

## **PRECAUTIONS TO PREVENT EMISSIONS OF UNCONFINED PARTICULATE MATTER**

Unconfined particulate matter emissions that may result from operations include:

- Vehicular traffic on paved and unpaved roads.
- Wind-blown dust from yard areas.
- Periodic abrasive blasting.

The following techniques will be used to prevent unconfined particulate matter emissions on an as-needed basis:

- Chemical or water application to:
  - Unpaved roads.
  - Unpaved yard areas.
- Paving and maintenance of roads, parking areas, and yards.
- Landscaping or planting of vegetation.
- Confining abrasive blasting where possible.
- Other techniques, as necessary.

**DOCUMENT II.E.5**

**FUGITIVE EMISSIONS IDENTIFICATION**

## **IDENTIFICATION OF FUGITIVE EMISSIONS BIG BEND STATION**

Fugitive emission sources located at the Big Bend Station consist of activities associated with the storage and handling of solid fuels, fly ash, limestone, gypsum, slag, and bottom ash. The following sections discuss how the fugitive emission sources are addressed in the application form.

### **Limestone Handling and Storage Fugitive Emission Sources**

All limestone handling and storage point and fugitive emission sources are addressed as one emissions unit. This emission unit includes point and fugitive emission sources LSH-001 through LSH-010.

### **Fly Ash Handling and Storage Fugitive Emission Sources**

All fly ash handling and storage fugitive emission sources are addressed as one emissions unit in the Big Bend Station Title V Air Operation Permit Application. This emission unit includes fugitive emission sources FA-002, FA-003, FA-005, and FA-007 through FA-010.

### **Gypsum Handling and Storage Fugitive Emission Sources**

All gypsum handling and storage fugitive emission sources are addressed as one emissions unit. This emission unit includes fugitive emission sources GH-001 through GH-017.

### **Solid Fuel Handling and Storage Fugitive Emission Sources**

All solid fuel handling and storage fugitive emission sources are addressed as one emissions unit in the Big Bend Station Title V Air Operation Permit Application. This emission unit includes fugitive emission sources FH-001 through FH-031, FH-036 through FH-047, FH-050 through FH-058, and FH-063 through FH-073.

### **Slag and Bottom Ash Handling Fugitive Emission Sources**

All slag and bottom ash handling fugitive emission sources are addressed as one emissions unit in the Big Bend Station Title V Operation Permit Application. This emission unit includes fugitive emission sources BH-001 through BH-004.

**DOCUMENT II.E.6**

**SUPPLEMENTAL INFORMATION FOR  
AIR CONSTRUCTION PERMIT APPLICATION**

**DOCUMENT II.E.6.1**  
**PROCESS DESCRIPTION**



## UNIT NOS. 1 AND 2 FGD SYSTEM DESCRIPTION

The Unit Nos. 1 and 2 flue gas desulfurization (FGD) system is based on limestone slurry scrubbing with *in situ* forced oxidation and is capable of producing a gypsum byproduct suitable for wallboard manufacturing and/or cement production. The FGD system is designed for sulfur dioxide (SO<sub>2</sub>) removal efficiencies of 85 percent or greater.

The FGD system consists of the following main subsystems:

- Gas handling.
- SO<sub>2</sub> absorption.
- Reagent preparation.
- Gypsum dewatering.

### 1.1 GAS HANDLING

Flue gas from the Unit Nos. 1 and 2 electrostatic precipitators is ducted to the booster fans which provide the additional energy necessary to overcome the gas side resistance of the downstream system equipment. The flue gas discharged from the booster fans is combined in a common plenum and routed to the absorber inlet. The existing chimney (Emission Point CS-001a) will remain in place for use during nonscrubbed operation of Unit Nos. 1 and/or 2.

The cleaned, cooled and saturated flue gas exiting the absorber module is ducted to a new wet chimney with an acid brick flue. The chimney is sized to prevent condensate reentrainment into the flue gas released to the atmosphere. Acidic condensate collected in the chimney base is collected and transferred to the absorber system.

### 1.2 SULFUR DIOXIDE ABSORPTION

Flue gas enters the SO<sub>2</sub> absorber where the gas is exposed to a limestone-based slurry spray to remove 85 percent or more of the inlet SO<sub>2</sub>.

The continuous emission monitoring system (CEMS) that will be used to measure emissions from the new flue gas treatment system is currently being designed. A detailed CEMS description will be submitted to the Florida Department of Environmental Protection (FDEP) for approval prior to FGD startup.

The single spray tower absorber is capable of handling 0 to 100 percent of the gas flow from Unit Nos. 1 and 2, simultaneously. Any gases not scrubbed will be directed to existing Stack 1a. Flue gas enters the absorber tower, flows countercurrently, and contacts the slurry spray consisting of calcium carbonate, calcium sulfite, and calcium sulfate. The slurry is distributed as finely divided droplets by multiple stages of spray banks throughout the absorber. The positioning of the spray banks and individual spray nozzles is engineered to ensure that the entire tower cross-sectional flow area is uniformly covered by a spray pattern. Each spray bank contains numerous individual spray nozzles, designed to generate droplet size distributions which provide sufficient surface area for mass transfer and, at the same time, cause minimum droplet entrainment in the gas stream. The absorber contains a dual-flow tray which maintains high removal efficiencies under a maximum flue gas and SO<sub>2</sub> loading conditions by increasing the mass transfer surface area of the slurry. Dibasic acid is also added for enhanced SO<sub>2</sub> removal.

Following contact with the slurry sprays, the scrubbed flue gas passes through mist eliminators which remove entrained slurry droplets from the gas stream. The mist eliminators are maintained in a clean condition by periodic washing. The water used for the mist eliminator wash supplements the source of makeup water to the FGD system. After the absorber recycle slurry has been exposed to the gas stream in the spray tower absorption section, the slurry enters the reaction tank at the bottom of the tower. Fresh makeup limestone reagent is added to the reaction tank as a slurry to maintain the design pH, typically in the range of 5.0 to 6.0. The reaction tank is designed to:

- Retain the circulating slurry to permit dissolution of fresh limestone and crystallization of the reaction products.
- Facilitate the oxidation of calcium sulfite to calcium sulfate.

To accomplish *in situ* oxidation within the reaction tank, air is sparged into the slurry at a pre-designed rate and submergence level. This action provides effective oxygen transfer to ensure virtually complete oxidation of calcium sulfite to calcium sulfate.

The residence time of solids in the reaction tank is generally 15 to 20 hours. This extended residence time provides an environment conducive for gypsum crystal growth.

Recirculation pumps take suction from the reaction tank as do the absorber bleed pumps which feed the primary dewatering system. The slurry in the tank is agitated to maintain the solids in suspension and prevent solids settling to the tank bottom.

### **1.3 REAGENT PREPARATION**

The reagent preparation system grinds limestone to produce a minimum 35-percent solids slurry for feed to the absorber. The new FGD system utilizes onsite reagent preparation equipment similar to the existing system supporting the Unit No. 4 FGD scrubber. As part of the Unit Nos. 1 and 2 FGD system project, one new wet ball mill will be added to the existing system for the production of the limestone reagent slurry. This new mill will be oversized for Unit Nos. 1 and 2 so that the mill may also be used as a partial backup for the two existing wet ball mill grinding systems.

The new reagent preparation system consists of:

- Storage silo discharge equipment and weigh feeder.
- One wet grinding mill.
- Slurry classification and recycle equipment.
- One reagent slurry storage tank.

Crushed limestone, which has been transported to the day storage silos by conveyors, is fed via a weigh feeding system from the silo into the wet grinding mill. The grinding water is primarily filtrate recovered from the gypsum processing system.

The pulverized limestone exiting the mill is classified in a set of hydroclones. The fine fraction (overflow), containing a minimum 35-percent weight limestone particles of typically 70 percent minus 200 mesh, flows to a limestone slurry storage tank while the coarse fraction (underflow) is recycled back to the mill for further grinding. Provisions are made to direct the overflow slurry either to the new storage tank, dedicated to Unit Nos. 1 and 2, or to one of the existing storage tanks, dedicated to Unit Nos. 3 and 4.

The new agitated reagent storage tank is equipped with limestone slurry feed pumps which operate a continuous flow recycle system feeding the absorber reaction tank. Fresh limestone feed is taken from this recycle loop upon system demand based primarily on pH control.

#### **1.4 GYPSUM DEWATERING**

The purpose of the dewatering system is to produce a gypsum product with 90 percent solids and recirculate process water to the absorption and reagent preparation systems.

The gypsum dewatering system design consists of:

- Primary dewatering hydroclones.
- Fines separation hydroclones.
- Filter feed tank.
- Vacuum drum filters.
- Filtrate and reclaim water equipment.

Absorber bleed slurry at a nominal 20-weight percent solids content is pumped from the absorber module through a set of hydroclones which concentrate the product to produce a

nominal 45-weight percent solids underflow. Product solids contained in the hydroclone underflow stream flow to the filter feed tank for secondary dewatering.

Most of the limestone, fine crystals (calcium sulfite and sulfate), and water are contained in the hydroclone overflow stream. This stream is sent to a set of final separation hydroclones. The larger particles are captured and report to the under flow which is recycled back to the absorber via the return slurry system. The over flow from the fines separation hydroclones contains very small particles (broken gypsum crystals and some fly ash) which must be removed from the FGD system. This stream is also the source of the purge stream to the wastewater treatment system, required to limit the amount of dissolved chlorides in the scrubbing slurry.

The filter feed tank is designed to accept and store the hydroclone underflow from both the existing and new FGD systems for subsequent feed to the vacuum filters. This tank is equipped with an agitator to maintain the solids in suspension.

The product solids are fed to the vacuum drum filters where the solids are concentrated to approximately 90 percent by weight. Provisions are included in the vacuum filter system to wash the gypsum cake with fresh water to remove traces of chloride to meet the gypsum byproduct specification for sale. The new vacuum filters are designed to replace the existing filters so that each filter will dewater the gypsum produced by both FGD systems.

The filtrate from the operating filter is collected in a filtrate tank, sized to store and return water to the reagent preparation and absorption systems. Water is pumped from the filtrate tank to:

- The existing Unit No. 4 filtrate return system.
- The new absorber reaction tank via the return slurry system.

- The overall plant makeup water tank.
- The area slurry line flush connections.

The new return slurry tank collects the primary dewatering hydroclone overflow slurry, fines separation hydroclone under flow, filtrate from the vacuum filter system, and transfer slurry from temporary absorber slurry storage. The return slurry is pumped back to the Unit Nos. 1 and 2 module for density control and to promote crystal growth. All or a portion of the slurry is directed to a set of chloride purge hydroclones. The hydroclone underflow drops back to the return slurry tank and the overflow, containing relatively high amounts of dissolved solids and low amounts of suspended solids, are directed to a chloride purge tank for transfer to the wastewater treatment system prior to discharge.

## LIMESTONE HANDLING SYSTEM DESCRIPTION

The existing limestone receiving and handling system starts at the limestone receiving hoppers in the limestone unloading facility and terminates at the discharge of the belt feeders which meter the limestone into ball mills which prepare the limestone feed for the Unit No. 4 FGD system.

In the existing system, limestone delivered by truck is unloaded into the receiving hoppers of the limestone receiving facility. Belt feeders meter the limestone onto 36-inch belt conveyor LB. A belt scale on conveyor LB tracks the quantity of limestone delivered to the plant.

The limestone is transferred from Conveyor LB to a 36-inch tripper conveyor in transfer house LL-1. The tripper conveyor stacks the limestone in a pile housed in a storage building. A portal type reclaimer reclaims limestone from the pile and deposits the material onto 24-inch belt conveyor LD at the rate of 300 tons per hour (tph).

Conveyor LD transfers the limestone onto 24-inch belt conveyor LE in transfer house LL-2. Conveyor LE raises the limestone to the top of two limestone storage silos. A bifurcated chute equipped with a diverting gate deposits the limestone into either of the two silos. A rotary type discharger and belt feeder, installed beneath each silo, transfers limestone to a corresponding ball mill. The limestone ground in the ball mills is mixed with water streams introduced into the mills and the slurries are carried into the FGD reagent tanks of Unit No. 4. The existing ball mills are 100 percent redundant. Each is capable of grinding 30 tph of limestone which is the combined limestone requirement if both Unit Nos. 3 and 4 are being scrubbed.

The system described above is presently supplying the limestone requirements of the FGD system serving Unit Nos. 3 and 4. To add a new FGD system for Unit Nos. 1 and 2, a new limestone silo, rotary unloader, belt feeder, and ball mill will be installed. The new

ball mill will provide the new FGD system with 41 tph of ground limestone. However, the new mill will be sized for a grinding capacity of 55 tph.

The new limestone silo and ball mill will be installed at the south end of the two existing silos. To divert limestone to the new silo, the existing bifurcated will be removed, and two new reversible belt conveyors LF and LG will be installed to supply the existing new silos.

The existing conveying system from storage pile to limestone silos has sufficient capacity to supply the new FGD System. Existing belt speeds, horsepower, and belt tensions will not be changed.

Addition of new limestone handling equipment creates new particulate matter emission sources which will operate simultaneously with the equipment currently used for supplying limestone to the Unit No. 4 FGD system. The new sources are conveyors LF and LG installed atop the silos for supplying limestone to the new silo. A baghouse will be included in the design to control particulate matter (PM) emissions from these new conveyor transfers.



## GYPSUM HANDLING SYSTEM DESCRIPTION

The existing two gypsum filters will be replaced by two new gypsum filters. Each new filter will be capable of dewatering the gypsum product of Unit Nos. 1 through 4. The existing conveying configuration, which is capable of directing gypsum to either the north stackout area or to the long-term storage area, will be retained.

Tampa Electric Company (TEC) maintains several long-term sales agreements for gypsum by-product as part of the efforts to ensure that the vast majority of the gypsum produced at Big Bend Station is recycled in a productive and environmentally sensitive manner. In addition to these agreements, TEC operates a concerted marketing effort designed to identify new byproduct customers.

Existing sales agreements account for approximately 375,000 tons of gypsum sales annually. TEC's current customers include clients in the wallboard, cement, and agricultural industries. TEC expects to renew all of these agreements over the next 18 to 24 months. An expansion of facilities at our wallboard customer coupled with a new extension of that sales agreement already provides the potential for an increase in gypsum sales that could be up to 800,000 tons annually. Even if only part of this potential is realized, TEC has an active interest from several large, established wallboard manufacturers evaluating new production capacity in the vicinity of Big Bend Station. This interest, coupled with our sales to the cement and agricultural markets, should provide adequate demand to allow TEC to market most, if not all, of the future gypsum production.

The FGD systems are designed to yield a high-quality gypsum product that makes TEC's gypsum attractive to a wide variety of users. TEC's history of producing high quality, nonhazardous gypsum is one of the principal reasons TEC continues to draw interest in this product from many firms.

TEC is also continuing the on-going program to identify new gypsum customers to develop the greatest number of possible alternative outlets for this product. TEC's market development not only looks at potential new customers, but at possible new uses for gypsum and more economical ways of transporting this material to end-users. With this strategy, TEC hopes not only to find new gypsum markets, but to expand traditional markets via low-cost forms of transportation.

**DOCUMENT II.E.6.2**

**DISPERSION MODELING DESCRIPTION**

**BIG BEND STATION  
UNITS 1 AND 2  
FLUE GAS DESULFURIZATION SYSTEM  
AIR DISPERSION MODELING**

**Prepared for:**



**Prepared by:**



*Environmental Consulting & Technology, Inc.*

*3701 Northwest 98<sup>th</sup> Street  
Gainesville, Florida 32606*

**ECT No. 98102-0200**

**June 1998**

**Revision 1, 07/20/98**

## TABLE OF CONTENTS

<u>Section</u>	<u>Page</u>
DISPERSION MODELING TECHNIQUES, INPUTS, AND RESULTS	1
<u>MODEL SELECTION</u>	1
<u>POLLUTANT EMISSION RATES</u>	2
<u>STACK PARAMETERS</u>	2
<u>GOOD ENGINEERING PRACTICE/DOWNWASH</u>	
<u>CONSIDERATIONS</u>	13
<u>RECEPTOR LOCATIONS</u>	16
<u>METEOROLOGICAL DATA</u>	16
<u>DISPERSION MODELING RESULTS</u>	22

## LIST OF TABLES

<u>Table</u>		<u>Page</u>
1	Big Bend Station - Combustion Units - Emission Rates for Dispersion Modeling - Scenario 1 - Units 1, 2, and 4 Scrubbed; Unit 3 Not Scrubbed	3
2	Big Bend Station - Combustion Units - Emission Rates for Dispersion Modeling - Scenario 2 - Units 1 and 4 Scrubbed; Units 2 and 3 Not Scrubbed	4
3	Big Bend Station - Combustion Units - Stack Parameters for Dispersion Modeling - Scenario 3 - Units 1 through 4 Scrubbed	10
4	Big Bend Station - Combustion Units - Stack Parameters for Dispersion Modeling - Scenario 4 - Units 1, 3, and 4 Scrubbed; Unit 2 Not Scrubbed	6
5	Big Bend Station - Noncombustion Emission Sources - PM <sub>10</sub> Emission Rates for Dispersion Modeling	7
6	Big Bend Station - Combustion Units - Stack Parameters for Dispersion Modeling - Scenario 1 - Units 1, 2, and 4 Scrubbed; Unit 3 Not Scrubbed	9
7	Big Bend Station - Combustion Units - Stack Parameters for Dispersion Modeling - Scenario 2 - Units 1 and 4 Scrubbed; Units 2 and 3 Not Scrubbed	10
8	Big Bend Station - Combustion Units - Stack Parameters for Dispersion Modeling - Scenario 3 - Units 1 through 4 Scrubbed	11
9	Big Bend Station - Combustion Units - Stack Parameters for Dispersion Modeling - Scenario 4 - Units 1, 3, and 4 Scrubbed; Unit 2 Not Scrubbed	12
10	Big Bend Station - Noncombustion Emission Sources - Emission Parameters for Dispersion Modeling	14
11	Big Bend Station - Stack and Structure Heights and Locations	17
12	Big Bend Station - Noncombustion Emission Source Locations	20

LIST OF TABLES  
(Continued, Page 2 of 2)

<u>Table</u>		<u>Page</u>
13	Big Bend Station - Modeled Ambient SO <sub>2</sub> Impacts	23
14	Big Bend Station - Modeled Ambient NO <sub>x</sub> Impacts	24
15	Big Bend Station - Modeled Ambient PM <sub>10</sub> Impacts	25
16	Big Bend Station - Modeled Ambient CO Impacts	26

LIST OF FIGURES

<u>Figure</u>		<u>Page</u>
1	Big Bend Station Structure Locations for Downwash Analysis	19



## DISPERSION MODELING TECHNIQUES, INPUTS, AND RESULTS

### MODEL SELECTION

The most recent regulatory version of the Industrial Source Complex Short-Term (ISCST3 Version 97363) dispersion model was used in the analyses of ambient sulfur dioxide (SO<sub>2</sub>), nitrogen oxides (NO<sub>x</sub>), respirable particulate matter (PM<sub>10</sub>), and carbon monoxide (CO) impacts caused by emissions from Big Bend Station. ISCST3 is a refined model appropriate for use under the following conditions:

- Industrial source complexes (i.e., multiple emission sources).
- Rural or urban areas.
- Flat or rolling terrain.
- Pollutant transport distances less than 50 kilometers (km).
- Multiple averaging periods (i.e., 3-hour, 24-hour, and annual).

ISCST3 was selected because:

- The Big Bend Station analysis falls within the ISCST3 applicability criteria.
- Per Chapter 40, Code of Federal Regulation (CFR), Part 51, Appendix W, the U.S. Environmental Protection Agency (EPA) has designated ISCST3 a preferred model. This designation means that EPA has determined that ISCST3 performs better under the criteria stated above than any other dispersion model.
- The Florida Department of Environmental Protection (FDEP) is also using ISCST3 to model ambient SO<sub>2</sub> levels from Big Bend Station for Title V permitting purposes.

Previous dispersion modeling of Big Bend Station has been conducted using other models. For example, SO<sub>2</sub> emissions from Big Bend Station were modeled in 1991 to demonstrate compliance for the Unit Nos. 3 and 4 flue gas desulfurization (FGD) integration using an earlier version of ISCST. Several versions of the SCREEN model have also been applied to Big Bend Station emissions. However, these older models were not used

for this ambient impact analysis because EPA and FDEP do not recognize superseded models as valid analytical tools.

### POLLUTANT EMISSION RATES

The pollutant emission rates for the Big Bend Station combustion units used in the modeling analysis for Big Bend Station are presented in Tables 1 through 4. Three potential FGD operating scenarios were modeled, as follows:

- Scenario 1—Unit Nos. 1, 2, and 4 scrubbed; Unit No. 3 not scrubbed.
- Scenario 2—Unit Nos. 1 and 4 scrubbed; Unit Nos. 2 and 3 not scrubbed.
- Scenario 3—Unit Nos. 1 through 4 scrubbed.
- Scenario 4—Unit No. 2 not scrubbed; Unit Nos. 1, 3, and 4 scrubbed.

The noncombustion emission sources PM<sub>10</sub> emission rates are presented in Table 5.

A scenario of Unit Nos. 2 and 4 scrubbed and Unit Nos. 1 and 3 not scrubbed was not modeled because this scenario is virtually identical to Scenario 2. A scenario of Unit No. 1 unscrubbed and Unit Nos. 2, 3, and 4 scrubbed was not modeled for the same reason. The existing base case of Unit Nos. 1 and 2 not scrubbed, Unit No. 3 scrubbed or not scrubbed, and Unit No. 4 scrubbed was not modeled because recently completed SO<sub>2</sub> modeling for Title V permit application purposes indicated the base case does not cause an exceedance of the national or Florida ambient air quality standards (AAQS). Because the modeling analysis must evaluate the potential worst-case conditions, all emission rates are based on the maximum permitted rate for the appropriate time period, as noted in the tables. *look at*

*uniform grid of receptors are a wide average*

### STACK PARAMETERS

*on the whole we think this is beneficial - lowering absolute emission higher but less than AAQS*

The stack parameters for the Big Bend Station combustion units used in the modeling analysis for Big Bend Station are presented in Tables 6 through 9. With the exception of Unit Nos. 1 and 2 operations with the FGD system, the stack heights, diameters, and exit temperatures of the boilers were obtained from the appropriate Title V Air Operation

**Table 1. Big Bend Station - Combustion Units - Emission Rates for Dispersion Modeling  
Scenario 1 - Units 1, 2, and 4 Scrubbed; Unit 3 Not Scrubbed**

Right E.R.  
Now  
SO<sub>2</sub>  
(Ann + 24hr) 3hr  
2100 2646  
2100 2646  
2100 2646  
447.4 447.4  
11.0 11.0  
60.5 60.5  
60.5 60.5  
687.9

Emissions Unit	Emission Rate							
	SO <sub>2</sub>		NO <sub>x</sub>		PM <sub>10</sub>		CO	
	(lb/MMBtu)	(g/sec)	(lb/MMBtu)	(g/sec)	(lb/MMBtu)	(g/sec)	(lb/MMBtu)	(g/sec)
Unit 1	0.82	417.1	1.545	785.9	0.1	50.9	0.023	11.7
Unit 2	0.82	412.9	1.545	777.9	0.1	50.3	0.023	11.6
Unit 3	5.4	2,799.8	0.70	362.9	0.1	51.8	0.023	11.9
Unit 4	0.82	447.4	0.60	327.3	0.03	16.4	0.029	15.8
CT 1	0.51	11.1	0.698	15.2	0.038	0.8	0.048	1.0
CT 2	0.51	61.0	0.698	83.6	0.038	4.5	0.048	5.7
CT 3	0.51	61.0	0.698	83.6	0.038	4.5	0.048	5.7

4210

Notes:

- All emission rates based on maximum permitted operation.
- Units 1 and 2 SO<sub>2</sub> emission rates based on design information.
- Units 1 and 2 PM<sub>10</sub> emission rates based on draft Title V operation permit conditions.
- Units 1 and 2 NO<sub>x</sub> and CO emission rates based on AP-42 emission factors.
- Unit 3 SO<sub>2</sub> emission rate based on reducing draft Title V operation permit condition from 6.5 to 5.4 lb/MMBtu.
- Unit 3 NO<sub>x</sub> and PM<sub>10</sub> emission rates based on draft Title V operation permit conditions.
- Unit 3 CO emission rate based on AP-42 emission factor.
- Unit 4 SO<sub>2</sub>, NO<sub>x</sub>, PM<sub>10</sub>, and CO emission rates based on draft Title V operation permit conditions.
- All CT emission rates based on AP-42 emission factors.

**Table 2. Big Bend Station - Combustion Units - Emission Rates for Dispersion Modeling  
Scenario 2 - Units 1 and 4 Scrubbed; Units 2 and 3 Not Scrubbed**

Emissions Unit	Emission Rate							
	SO <sub>2</sub>		NO <sub>x</sub>		PM <sub>10</sub>		CO	
	(lb/MMBtu)	(g/sec)	(lb/MMBtu)	(g/sec)	(lb/MMBtu)	(g/sec)	(lb/MMBtu)	(g/sec)
Unit 1	0.82	417.1	1.545	785.9	0.1	50.9	0.023	11.7
Unit 2	3.6	1,812.6	1.545	777.9	0.1	50.3	0.023	11.6
Unit 3	3.6	1,866.6	0.70	362.9	0.1	51.8	0.023	11.9
Unit 4	0.82	447.4	0.60	327.3	0.03	16.4	0.029	15.8
CT 1	0.51	11.1	0.698	15.2	0.038	0.8	0.048	1.0
CT 2	0.51	61.0	0.698	83.6	0.038	4.5	0.048	5.7
CT 3	0.51	61.0	0.698	83.6	0.038	4.5	0.048	5.7

Notes:

All emission rates based on maximum permitted operation.

Unit 1 SO<sub>2</sub> emission rate based on design information.

Unit 2 SO<sub>2</sub> emission rate based on reducing draft Title V operation permit condition from 6.5 to 3.6 lb/MMBtu.

Units 1 and 2 PM<sub>10</sub> emission rates based on draft Title V operation permit conditions.

Units 1 and 2 NO<sub>x</sub> and CO emission rates based on AP-42 emission factors.

Unit 3 SO<sub>2</sub> emission rate based on reducing draft Title V operation permit condition from 6.5 to 3.6 lb/MMBtu.

Unit 3 NO<sub>x</sub> and PM<sub>10</sub> emission rates based on draft Title V operation permit conditions.

Unit 3 CO emission rate based on AP-42 emission factor.

Unit 4 SO<sub>2</sub>, NO<sub>x</sub>, PM<sub>10</sub>, and CO emission rates based on draft Title V operation permit conditions.

All CT emission rates based on AP-42 emission factors.

E.R.  
Ann 24h 3hr  
2100 2646  
2100 2646  
2100 2646  
447.4 447.4  
11.0 11.0  
60.5 60.5  
60.5 60.5  
6879

4676

**Table 3. Big Bend Station - Combustion Units - Emission Rates for Dispersion Modeling  
Scenario 3 - Units 1 Through 4 Scrubbed**

Emissions Unit	Emission Rate							
	SO <sub>2</sub>		NO <sub>x</sub>		PM <sub>10</sub>		CO	
	(lb/MMBtu)	(g/sec)	(lb/MMBtu)	(g/sec)	(lb/MMBtu)	(g/sec)	(lb/MMBtu)	(g/sec)
Unit 1	0.82	417.1	1.545	785.9	0.1	50.9	0.023	11.7
Unit 2	0.82	412.9	1.545	777.9	0.1	50.3	0.023	11.6
Unit 3	0.82	425.2	0.60	311.1	0.1	51.8	0.023	11.9
Unit 4	0.82	447.4	0.60	327.3	0.03	16.4	0.029	15.8
CT 1	0.51	11.1	0.698	15.2	0.038	0.8	0.048	1.0
CT 2	0.51	61.0	0.698	83.6	0.038	4.5	0.048	5.7
CT 3	0.51	61.0	0.698	83.6	0.038	4.5	0.048	5.7

Notes:

All emission rates based on maximum permitted operation.

Units 1 and 2 SO<sub>2</sub> emission rates based on design information.

Units 1 and 2 PM<sub>10</sub> emission rates based on draft Title V operation permit conditions.

Units 1 and 2 NO<sub>x</sub> and CO emission rates based on AP-42 emission factors.

Unit 3 SO<sub>2</sub>, NO<sub>x</sub>, and PM<sub>10</sub> emission rates based on draft Title V operation permit conditions.

Unit 3 CO emission rate based on AP-42 emission factor.

Unit 4 SO<sub>2</sub>, NO<sub>x</sub>, PM<sub>10</sub>, and CO emission rates based on draft Title V operation permit conditions.

All CT emission rates based on AP-42 emission factors.

24hr  
2100  
2100  
2100  
447.4  
11.0  
61.0  
61.0  
6879

1835 ← 27% or 73% clean

**Table 4. Big Bend Station - Combustion Units - Emission Rates for Dispersion Modeling Scenario 4 - Units 1, 3, and 4 Scrubbed; Unit 2 Not Scrubbed**

Emissions	Emission Rate							
	SO <sub>2</sub>		NO <sub>x</sub>		PM <sub>10</sub>		CO	
	(lb/MMBtu)	(g/sec)	(lb/MMBtu)	(g/sec)	(lb/MMBtu)	(g/sec)	(lb/MMBtu)	(g/sec)
Unit 1	<u>0.82</u>	417.1	1.545	785.9	0.1	50.9	0.023	11.7
Unit 2	5.4	2718.9	1.545	777.9	0.1	50.3	0.023	11.6
Unit 3	0.82	425.2	0.60	311.1	0.1	51.8	0.023	11.9
Unit 4	0.82	447.4	0.60	327.3	0.03	16.4	0.029	15.8
CT 1	0.51	11.1	0.698	15.2	0.038	0.8	0.048	1.0
CT 2	0.51	61.0	0.698	83.6	0.038	4.5	0.048	5.7
CT 3	0.51	61.0	0.698	83.6	0.038	4.5	0.048	5.7

Notes:

All emission rates based on maximum permitted operation.

Unit 1 SO<sub>2</sub> emission rate based on design information.

Unit 2 SO<sub>2</sub> emission rate based on reducing draft Title V operation permit condition from 6.5 to 5.4 lb/MMBtu.

Units 1 and 2 PM<sub>10</sub> emission rates based on draft Title V operation permit conditions.

Units 1 and 2 NO<sub>x</sub> and CO emission rates based on AP-42 emission factors.

Unit 3 SO<sub>2</sub>, NO<sub>x</sub>, and PM<sub>10</sub> emission rates based on draft Title V operation permit conditions.

Unit 3 CO emission rate based on AP-42 emission factor.

Unit 4 SO<sub>2</sub>, NO<sub>x</sub>, PM<sub>10</sub>, and CO emission rates based on draft Title V operation permit conditions.

All CT emission rates based on AP-42 emission factors.

**Table 5. Big Bend Station - Noncombustion Emission Sources  
PM<sub>10</sub> Emission Rates for Dispersion Modeling**

Process Area	Emission Source	Emission Source ID	PM <sub>10</sub> Emission Rate	
			(lb/hr)	(g/sec)
Fuelyard	Barge Clamshell to Conveyor D1	FH-001	0.17	0.02
	Barge Bucket Elevator to Conveyor A1	FH-002	0.17	0.02
	Conveyor A1 to Conveyor B1	FH-003	0.17	0.02
	Conveyor B1 to Conveyor D1	FH-004	0.17	0.02
	Self-Unloading Barge to Conveyor D1	FH-005	0.17	0.02
	Conveyor D1 to Conveyor E1	FH-006	0.17	0.02
	Conveyor E1 to Conveyor Y or F1	FH-007	0.17	0.02
	Conveyor Y to Conveyor Z	FH-008a	0.17	0.02
	Conveyor Z to West Emergency Storage Pile	FH-008b	0.51	0.06
	West Emergency Storage Pile Maintenance	FH-009	0.95	0.11
	West Emergency Storage Pile Storage	FH-010	1.10	0.13
	West Emergency Storage Pile Reclaim	FH-011a	0.26	0.03
	Portable Conveyor to Conveyor F1	FH-011b	0.17	0.02
	Conveyor Z to Conveyor P	FH-012	0.17	0.02
	Conveyor P to Intermediate Conveyor	FH-013	0.17	0.02
	Intermediate Conveyor to North Stacker	FH-014	0.17	0.02
	North Stacker to North/Center Storage Piles	FH-015	0.51	0.06
	Bucket Elevator Reclaim to North Stacker	FH-016	0.26	0.03
	North Stacker to Conveyor P	FH-017	0.17	0.02
	North Storage Pile Maintenance	FH-018	0.95	0.11
	North Storage Pile Storage	FH-019	27.05	3.15
	Center Storage Pile Maintenance	FH-020	0.95	0.11
	Center Storage Pile Storage	FH-021	21.30	2.48
	Conveyor F1 to South Stacker	FH-022	0.17	0.02
	South Stacker to South/Center Storage Piles	FH-023	0.51	0.06
	South Reclaimer to South Reclaimer Conveyor	FH-024	0.26	0.03
	South Reclaimer Conveyor to Conveyor F1	FH-025	0.17	0.02
	South Storage Pile Maintenance	FH-026	0.95	0.11
	South Storage Pile Storage	FH-027	22.20	2.58
	Conveyor P to Conveyor J2	FH-028	0.17	0.02
	Conveyor J2 to Conveyor Q2	FH-029	0.17	0.02
	Conveyor F1 to Conveyor J1	FH-030	0.17	0.02
	Conveyor J1 to Conveyor Q1	FH-031	0.17	0.02
	Conveyors Q1 and Q2 to Blending Bins	FH-032 - FH-035	0.20	0.02
	Blending Bins to Conveyors T1 and T2	FH-036 - FH-047	0.34	0.04
	Conveyor T1 to Crusher 1	FH-048	0.10	0.01
	Conveyor T2 to Crusher 2	FH-049	0.10	0.01
	Crusher to Conveyor W1	FH-050	0.17	0.02
	Crusher to Conveyor W2	FH-051	0.17	0.02
	Conveyor U to East Emergency Storage Pile	FH-052	0.51	0.06
	East Emergency Storage Pile Maintenance	FH-053	0.95	0.11
	East Emergency Storage Pile Storage	FH-054	0.40	0.05
	Conveyor W1 to Conveyor L1	FH-055	0.17	0.02
	Conveyor W2 to Conveyor L2	FH-056	0.17	0.02

9.8295

**Table 5. Big Bend Station - Noncombustion Emission Sources**  
**PM<sub>10</sub> Emission Rates for Dispersion Modeling (Page 2 of 2)**

Process Area	Emission Source	Emission Source ID	PM <sub>10</sub> Emission Rate	
			(lb/hr)	(g/sec)
Fuelyard (Cont.)	East Emergency Storage Pile Reclaim to "K" Feeders	FH-057	0.26	0.03
	"K" Feeders to Conveyors L1 or L2	FH-058	0.17	0.02
	Conveyors L1 and L2 to Fuel Bunkers	FH-059 - FH-062	0.20	0.02
	Transloading Storage Pile Maintenance	FH-063	0.51	0.06
	Transloading Storage Pile Reclaim to Loadout Conveyor	FH-064	0.02	0.002
	Transloading Loadout Conveyor to Rail Loading Conveyor	FH-065	0.01	0.001
	Transloading Railcar Loading	FH-066	0.03	0.003
	Non-TEC Fuel Storage Pile Reclaim to Loadout Conveyor	FH-067	0.02	0.002
	Non-TEC Fuel Truck Loading	FH-068	0.03	0.003
	TEC Fuel Truck Loading	FH-069	0.02	0.002
	Long -Term Storage Pile	FH-070	3.95	0.46
	Long-Term Storage Pile Maintenance	FH-071	0.95	0.11
Fly Ash	Transfers into Silo 1	FA-001	5.16	0.60
	Dry Transfer from Silo 1 to Trucks	FA-002	0.03	0.003
	Wet Transfer from Silo 1 to Trucks	FA-003	0.01	0.001
	Transfer into Silo 2	FA-004	5.16	0.60
	Dry Transfer from Silo 2 to Trucks	FA-005	0.03	0.003
	Transfer into Silo 3	FA-006	0.20	0.02
	Dry Transfer from Silo 3 to Trucks	FA-007	0.03	0.003
	Wet Transfer from Silo 3 to Trucks	FA-008	0.01	0.001
Gypsum	Stacker to North Stackout Pile	GH-001	0.04	0.005
	North Stackout Pile	GH-002	0.33	0.04
	North Stackout Pile Maintenance	GH-003	1.07	0.12
	Transfer from North Stackout Pile to Loadout Conveyor	GH-004a	0.04	0.005
	Loadout Conveyor to Truck	GH-004b	0.04	0.005
	Conveyor GD to Conveyor GE	GH-007	0.01	0.001
	Conveyor GE to Conveyor GF	GH-008	0.01	0.001
	Conveyor GF to Radial Stacker	GH-009	0.01	0.001
	Radial Stacker to South Stackout Pile	GH-010	0.04	0.005
	South Stackout Pile	GH-011	0.31	0.04
	South Stackout Pile Maintenance	GH-012	1.07	0.12
	Long-Term Storage Pile Maintenance	GH-013	1.07	0.12
	Long-Term Storage Pile	GH-014	37.99	4.42
Transfer from Long-Term Storage to Trucks	GH-015	0.04	0.005	
Limestone	Railcar/Truck Unloading to Hoppers	LSH-001	0.58	2.52
	Conveyor LB to Conveyor LC	LSH-002	0.01	0.06
	Conveyor LD to Conveyor LE	LSH-003	0.01	0.06
	Conveyor LE to Conveyor LF and Silo A	LSH-004/005	0.02	0.08
	Conveyor LF to Conveyor LG and Silo B	LSH-006/007	0.02	0.08
	Conveyor LG to Silo C	LSH-008	0.01	0.02



R = Reduce  
 S = Scrub  
 - = Some

**Table 6. Big Bend Station - Combustion Units - Stack Parameters for Dispersion Modeling  
 Scenario 1 - Units 1, 2, and 4 Scrubbed; Unit 3 Not Scrubbed**

Emissions Unit	Stack Height		Stack Gas Temperature		Stack Gas Velocity		Stack Diameter	
	(ft)	(m)	(°F)	(K)	(ft/min)	(m/sec)	(ft)	(m)
Unit 1	490	149.4	127	326 <sup>R</sup>	3,600	18.29 <sup>R</sup>	29	8.8
Unit 2	490	149.4	127	326 <sup>R</sup>	3,600	18.29 <sup>R</sup>	29	8.8
Unit 3	490	149.4	308	426 <sup>-</sup>	3,072	15.61 <sup>-</sup>	24	7.3
Unit 4	490	149.4	127	326 <sup>R</sup>	4,698	23.87 <sup>-</sup>	24	7.3
CT 1	35	10.7	1011	817 <sup>-</sup>	5,510	28.00 <sup>-</sup>	11	3.4
CT 2	75	22.9	928	771 <sup>-</sup>	6,967	35.40 <sup>-</sup>	17	5.1
CT 3	75	22.9	928	771 <sup>-</sup>	6,967	35.40 <sup>-</sup>	17	5.1

S  
 S  
 S

Notes:

Units 1 and 2 share one stack. Stack data represents both units operating at maximum capacity.  
 Units 1 and 2 stack parameters based on design information.  
 All other stack parameters based on Title V operation permit SO<sub>2</sub> dispersion modeling inputs.

5c scrub  
 R = Reduce  
 - = same

**Table 7. Big Bend Station - Combustion Units - Stack Parameters for Dispersion Modeling  
 Scenario 2 - Units 1 and 4 Scrubbed; Units 2 and 3 Not Scrubbed**

S  
 S

Emissions Unit	Stack Height		Stack Gas Temperature		Stack Gas Velocity		Stack Diameter	
	(ft)	(m)	(°F)	(K)	(ft/min)	(m/sec)	(ft)	(m)
Unit 1	490	149.4	127	326 R	1,800	9.15 R	29	8.8
Unit 2	490	149.4	294	419 -	3,478	17.67 R	24	7.3
Unit 3	490	149.4	308	426 -	3,072	15.61 -	24	7.3
Unit 4	490	149.4	127	326 -	4,698	23.87 -	24	7.3
CT 1	35	10.7	1011	817 -	5,510	28.00 -	11	3.4
CT 2	75	22.9	928	771 -	6,967	35.40 -	17	5.1
CT 3	75	22.9	928	771 -	6,967	35.40 -	17	5.1

Notes:

Units 1 stack parameters based on design information.

All other stack parameters based on Title V operation permit SO<sub>2</sub> dispersion modeling inputs.

Table 8. Big Bend Station - Combustion Units - Stack Parameters for Dispersion Modeling  
Scenario 3 - Units 1 Through 4 Scrubbed

S = Scrubbed  
R = Reduce  
- = same

Emissions Unit	Stack Height		Stack Gas Temperature		Stack Gas Velocity		Stack Diameter	
	(ft)	(m)	(°F)	(K)	(ft/min)	(m/sec)	(ft)	(m)
S Unit 1	490	149.4	127	326 R	3,600	18.29 R	29	8.8
S Unit 2	490	149.4	127	326 R	3,600	18.29 R	29	8.8
S Unit 3	490	149.4	127	326 R	3,072	15.61 -	24	7.3
S Unit 4	490	149.4	127	326 -	4,698	23.87 -	24	7.3
CT 1	35	10.7	1011	817 -	5,510	28.00 -	11	3.4
CT 2	75	22.9	928	771 -	6,967	35.40 -	17	5.1
CT 3	75	22.9	928	771 -	6,967	35.40 -	17	5.1

Notes:

Units 1 and 2 share one stack. Stack data represents both units operating at maximum capacity.

Units 1 and 2 stack parameters based on design information.

All other stack parameters based on Title V operation permit SO<sub>2</sub> dispersion modeling inputs.

S ≡ Scrubbed  
 R ≡ Reduced  
 — ≡ Same

Table 9. Big Bend Station - Combustion Units - Stack Parameters for Dispersion Modeling  
 Scenario 4 - Units 1, 3, and 4 Scrubbed; Unit 2 Not Scrubbed

Emissions Unit	Stack Height		Stack Gas Temperature		Stack Gas Velocity		Stack Diameter	
	(ft)	(m)	(°F)	(K)	(ft/min)	(m/sec)	(ft)	(m)
S Unit 1	490	149.4	127	326 R	1,800	9.15 R	29	8.8
Unit 2	490	149.4	294	419 —	3,487	17.72 R	24	7.3
Unit 3	490	149.4	127	326 R	3,072	15.61 —	24	7.3
Unit 4	490	149.4	127	326 —	4,698	23.87 —	24	7.3
CT 1	35	10.7	1011	817 —	5,510	28.00	11	3.4
CT 2	75	22.9	928	771 —	6,967	35.40	17	5.1
CT 3	75	22.9	928	771 —	6,967	35.40	17	5.1

Notes:

Unit 1 stack parameters based on design information.

All other stack parameters based on Title V operation permit SO<sub>2</sub> dispersion modeling inputs.

Permit application. Stack exit velocities for the boilers were calculated from continuous emissions monitoring system (CEMS) volumetric flow measurements taken in 1995, as summarized in Table 3. CEMS volumetric flow data from 1995 was used because 1995 was the last full year of nonintegrated operation for Units 3 and 4. Stack parameters for the operation of Unit Nos. 1 and 2 with the FGD system were obtained from design data.

All of the combustion turbine stack parameters were obtained from Big Bend Station.

The stack parameters for the noncombustion PM<sub>10</sub> emission sources are presented in Table 10.

### **GOOD ENGINEERING PRACTICE/DOWNWASH CONSIDERATIONS**

The 1977 Clean Air Act Amendments require that the degree of emission limitation required for control of any pollutant not be affected by a stack height that exceeds good engineering practice (GEP) or any other dispersion technique. On July 8, 1985, EPA promulgated final stack height regulations (40 CFR 51), in which GEP stack height is defined as the higher of 65 meters, or a height established by applying the formula:

$$H_g = H + 1.5 L$$

where: H<sub>g</sub> = GEP stack height.

H = height of the structure or nearby structure.

L = lesser dimension (height or projected width) of the nearby structure.

Nearby is defined as a distance up to five times the lesser of the height or width dimension of a structure or terrain feature, but not greater than 800 meters. While GEP stack height regulations require that a stack height used in modeling for determining compliance with AAQS and prevention of significant deterioration (PSD) increments not exceed the GEP stack height, the actual stack height may be greater.

The EPA guidelines for application of the stack height regulations were followed in determining the GEP stack height for each stack.

**Table 10. Big Bend Station - Noncombustion Emission Sources  
Emission Parameters for Dispersion Modeling**

Process Area	Emission Source ID	Source Type	Exit Height (m)	Exit Temperature* (K)	Exit Velocity† (m/s)	Exit Diameter (m)
Fuelyard	FH-001	Fugitive	13.8	Ambient	0.001	1.00
	FH-002	Fugitive	13.8	Ambient	0.001	1.00
	FH-003	Fugitive	13.5	Ambient	0.001	1.00
	FH-004	Fugitive	16.8	Ambient	0.001	1.00
	FH-005	Fugitive	4.6	Ambient	0.001	1.00
	FH-006	Fugitive	7.3	Ambient	0.001	1.00
	FH-007	Fugitive	11.4	Ambient	0.001	1.00
	FH-008a	Fugitive	7.0	Ambient	0.001	1.00
	FH-008b	Fugitive	18.3	Ambient	0.001	1.00
	FH-009	Area	8.0	45.0	45.0	N/A
	FH-010	Area	8.0	45.0	45.0	N/A
	FH-011a	Fugitive	1.8	Ambient	0.001	1.00
	FH-011b	Fugitive	1.8	Ambient	0.001	1.00
	FH-012	Fugitive	12.2	Ambient	0.001	1.00
	FH-013	Fugitive	9.6	Ambient	0.001	1.00
	FH-014	Fugitive	9.6	Ambient	0.001	1.00
	FH-015	Fugitive	16.4	Ambient	0.001	1.00
	FH-016	Fugitive	1.5	Ambient	0.001	1.00
	FH-017	Fugitive	4.9	Ambient	0.001	1.00
	FH-018	Area	7.6	396.0	84.0	N/A
	FH-019	Area	7.6	396.0	84.0	N/A
	FH-020	Area	7.6	350.0	61.0	N/A
	FH-021	Area	7.6	350.0	61.0	N/A
	FH-022	Fugitive	9.6	Ambient	0.001	1.00
	FH-023	Fugitive	16.4	Ambient	0.001	1.00
	FH-024	Fugitive	4.6	Ambient	0.001	1.00
	FH-025	Fugitive	9.6	Ambient	0.001	1.00
	FH-026	Area	7.6	366.0	61.0	N/A
	FH-027	Area	7.6	366.0	61.0	N/A
	FH-028	Fugitive	7.4	Ambient	0.001	1.00
	FH-029	Fugitive	14.4	Ambient	0.001	1.00
	FH-030	Fugitive	7.4	Ambient	0.001	1.00
	FH-031	Fugitive	14.4	Ambient	0.001	1.00
	FH-032 - FH-035	Point	7.6	Ambient	21.89	0.51
FH-036 - FH-047	Fugitive	1.8	Ambient	0.001	1.00	
FH-048	Point	21.8	Ambient	21.89	1.00	
FH-049	Point	21.8	Ambient	21.89	1.00	
FH-050	Fugitive	3.0	Ambient	0.001	1.00	
FH-051	Fugitive	3.0	Ambient	0.001	1.00	
FH-052	Fugitive	12.0	Ambient	0.001	1.00	
FH-053	Area	6.1	18.0	18.0	N/A	
FH-054	Area	6.1	18.0	18.0	N/A	
FH-055	Fugitive	13.0	Ambient	0.001	1.00	
FH-056	Fugitive	13.0	Ambient	0.001	1.00	

\*East-west length of area source in meters.

†North-south length of area source in meters.

**Table 10. Big Bend Station - Noncombustion Emission Sources  
Emission Parameters for Dispersion Modeling (Page 2 of 2)**

Process Area	Emission Source ID	Source Type	Exit Height (m)	Exit Temperature* (K)	Exit Velocity† (m/s)	Exit Diameter (m)
Fuelyard (Cont.)	FH-057	Fugitive	6.0	Ambient	0.001	1.00
	FH-058	Fugitive	6.0	Ambient	0.001	1.00
	FH-059 - FH-062	Point	57.9	Ambient	21.89	1.00
	FH-063	Area	8.0	45.0	45.0	N/A
	FH-064	Fugitive	1.8	Ambient	0.001	1.00
	FH-065	Fugitive	6.0	Ambient	0.001	1.00
	FH-066	Fugitive	1.8	Ambient	0.001	1.00
	FH-067	Fugitive	6.0	Ambient	0.001	1.00
	FH-068	Fugitive	6.0	Ambient	0.001	1.00
	FH-069	Fugitive	6.0	Ambient	0.001	1.00
	FH-070	Area	7.6	122.0	46.0	N/A
FH-071	Area	7.6	122.0	46.0	N/A	
Fly Ash	FA-001	Point	31.1	394.0	15.85	0.76
	FA-002	Fugitive	3.0	Ambient	0.001	1.00
	FA-003	Fugitive	3.0	Ambient	0.001	1.00
	FA-004	Point	31.1	394.0	15.85	0.76
	FA-005	Fugitive	3.0	Ambient	0.001	1.00
	FA-006	Point	34.4	394	15.58	0.27
	FA-007	Fugitive	3.0	Ambient	0.001	1.00
	FA-008	Fugitive	3.0	Ambient	0.001	1.00
Gypsum	GH-001	Fugitive	10.9	Ambient	0.001	1.00
	GH-002	Area	6.1	38.0	38.0	N/A
	GH-003	Area	6.1	38.0	38.0	N/A
	GH-004a	Fugitive	3.0	Ambient	0.001	1.00
	GH-004b	Fugitive	3.0	Ambient	0.001	1.00
	GH-007	Fugitive	4.2	Ambient	0.001	1.00
	GH-008	Fugitive	4.2	Ambient	0.001	1.00
	GH-009	Fugitive	11.9	Ambient	0.001	1.00
	GH-010	Fugitive	13.9	Ambient	0.001	1.00
	GH-011	Area	6.1	38.0	38.0	N/A
	GH-012	Area	6.1	38.0	38.0	N/A
	GH-013	Area	6.1	244.0	122.0	N/A
	GH-014	Area	6.1	244.0	122.0	N/A
	GH-015	Fugitive	3.0	Ambient	0.001	1.00
	Limestone	LSH-001	Point	3.0	Ambient	21.73
LSH-002		Point	13.9	Ambient	20.70	0.15
LSH-003		Point	13.9	Ambient	20.70	0.15
LSH-004/005		Point	30.8	Ambient	14.29	0.15
LSH-006/007		Point	30.8	Ambient	14.29	0.15
LSH-008		Point	30.8	Ambient	7.76	0.15

\*East-west length of area source in meters.

†North-south length of area source in meters.

The complex downwash analysis was performed using the Building Profile Input program (BPIP, version 95086) to determine the appropriate downwash parameters for

ISCST3. The Big Bend Station structure locations and heights are provided in Table 11 and are presented in Figure 1. Combustion source stack locations and heights are also provided in this table and figure. Emission locations and heights for the noncombustion PM<sub>10</sub> emission sources are provided in Table 12.

### RECEPTOR LOCATIONS

Receptors were placed at locations considered to be ambient air, which is defined at 40 CFR 50.1(e) as that portion of the atmosphere, external to buildings, to which the general public has access. Those portions of Big Bend Station with restricted access were not considered ambient air.

Receptor locations were selected consistent with the definition of ambient air. Discrete receptors were placed on the restricted area boundaries at both stations. At Big Bend Station, additional discrete receptors were placed at 10 degree (°) increments, beginning at 10° on rings at 1,000, 1,250, 1,500, and 1,750 meters if the specific point was an ambient air location. Complete rings with receptors located at 10° increments, beginning at 10°, were located at 250 meter increments from 2,000 to 7,000 meters, and at 8,000, 9,000, 10,000, 12,000, 15,000, and 20,000 meters. This receptor grid was selected to be consistent with the grid used in the FDEP dispersion modeling.

### METEOROLOGICAL DATA

EPA dispersion modeling guidance recommends that modeling be conducted using one year of onsite meteorological, if available. Otherwise, the guidance recommends that modeling be conducted using the most recently available five years of meteorological data collected at a nearby observation station. Following this guidance, the selected meteorological data set included St. Petersburg/Clearwater International Airport (SPG) surface observations and mixing heights derived from SPG surface data and Ruskin (RUS) upper





**Table 11. Big Bend Station - Stack and Structure Heights and Locations (Page 2 of 2)**

Stack or Structure Name	Height (ft)	Stack /Structure Location*		Stack or Structure Name	Height (ft)	Stack /Structure Location*	
		East/West (ft)	North/South (ft)			East/West (ft)	North/South (ft)
Boilers 1, 2, and 3 Structure	192	-38	105	Units 1/2 Scrubber†	156	-220	-224
		-61	105				
		-61	96				
		-76	96				
		-76	105				
		-91	105				
		-91	113				
		-153	113				
		-153	122				
		-179	122				
		-179	167				
		-217	167				
		-217	122				
		-285	122				
		-285	184				
		-317	184				
		-317	143				
		-343	143				
		-343	139				
		-418	139				
		-418	214				
		-473	214				
		-473	292				
		-444	292				
		-444	298				
		-384	298				
		-384	284				
		-345	284				
		-345	298				
		-236	298				
-236	284						
-197	284						
-197	298						
-88	298						
-88	284						
-49	284						
-49	298						
-38	298						

\*Locations are relative to the Unit 3 stack. Positive directions are east and north. Negative directions are west and south.

†Cited location is the center point of a cylindrical scrubber 60 feet in diameter.

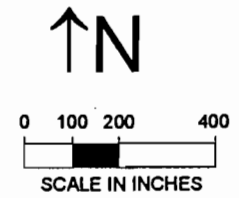
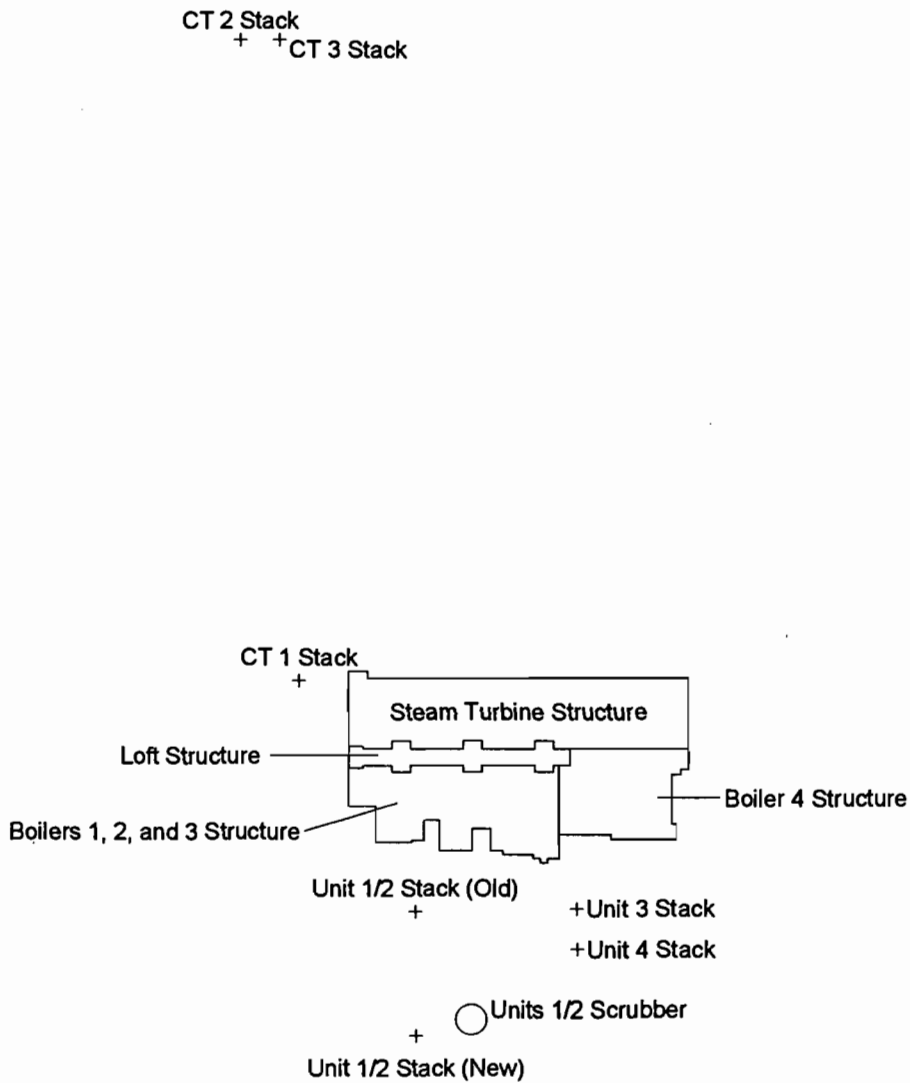

FIGURE 1.

**BIG BEND STATION STRUCTURE LOCATIONS  
FOR DOWNWASH ANALYSIS**

Source: ECT, 1998.



**Table 12. Big Bend Station - Noncombustion Emission Source Locations**

Process Area	Emission Source ID	Location Relative to Unit 3 Stack		UTM Coordinates	
		East-West (ft)	North-South (ft)	Easting (m)	Northing (m)
Fuelyard	FH-001	-3,066	673	360883	3075266
	FH-002	-3,059	595	360885	3075242
	FH-003	-3,059	595	360885	3075242
	FH-004	-3,051	502	360888	3075214
	FH-005	-3,041	381	360891	3075177
	FH-006	-3,028	306	360895	3075154
	FH-007	-2,857	307	360947	3075155
	FH-008a	-2,860	338	360946	3075164
	FH-008b	-2,691	385	360998	3075178
	FH-009	-2,691	385	360998	3075178
	FH-010	-2,691	385	360998	3075178
	FH-011a	-2,765	307	360975	3075155
	FH-011b	-2,765	307	360975	3075155
	FH-012	-2,838	605	360953	3075245
	FH-013	-2,104	612	361177	3075248
	FH-014	-2,077	612	361185	3075248
	FH-015	-2,071	523	361187	3075220
	FH-016	-2,071	523	361187	3075220
	FH-017	-2,044	612	361195	3075248
	FH-018	-2,626	665	361017	3075264
	FH-019	-2,626	665	361017	3075264
	FH-020	-2,511	360	361052	3075171
	FH-021	-2,511	360	361052	3075171
	FH-022	-2,074	320	361186	3075159
	FH-023	-2,073	241	361186	3075134
	FH-024	-2,073	241	361186	3075134
	FH-025	-2,048	321	361194	3075159
	FH-026	-2,519	66	361050	3075081
	FH-027	-2,519	66	361050	3075081
	FH-028	-1,210	610	361449	3075247
	FH-029	-1,215	469	361448	3075204
	FH-030	-1,216	310	361447	3075156
	FH-031	-1,215	452	361448	3075199
	FH-032	-871	680	361552	3075268
	FH-033	-871	610	361552	3075247
	FH-034	-871	541	361552	3075226
	FH-035	-871	464	361552	3075202
	FH-036 - FH-047	-910	583	361541	3075239
	FH-048	-909	59	361541	3075079
	FH-049	-878	58	361550	3075079
	FH-050	-909	89	361541	3075088
	FH-051	-878	89	361550	3075088
	FH-052	-991	90	361516	3075088
	FH-053	-1,017	66	361508	3075081
	FH-054	-1,017	66	361508	3075081
	FH-055	-1,000	305	361513	3075154
	FH-056	-975	317	361521	3075158

Note: UTM coordinates for Unit 3 stack in meters are Zone 17, 361818 E., 3075061 N.

**Table 12. Big Bend Station - Noncombustion Emission Source Locations (Page 2 of 2)**

Process Area	Emission Source ID	Location Relative to Unit 3 Stack		UTM Coordinates	
		East-West (ft)	North-South (ft)	Easting (m)	Northing (m)
Fuelyard (Cont.)	FH-057	-1,041	305	361501	3075154
	FH-058	-1,041	322	361501	3075159
	FH-059	-358	333	361709	3075163
	FH-060	-209	336	361754	3075163
	FH-061	-62	338	361799	3075164
	FH-062	127	338	361857	3075164
	FH-063	-2,691	385	360998	3075178
	FH-064	-2,622	406	361019	3075185
	FH-065	-2,508	-246	361053	3074986
	FH-066	-2,192	-235	361150	3074989
	FH-067	-1,082	182	361488	3075116
	FH-068	-1,082	182	361488	3075116
	FH-069	-1,267	560	361432	3075232
	FH-070	-2,474	-209	361064	3074997
FH-071	-2,472	-209	361064	3074997	
Fly Ash	FA-001	-343	-147	361713	3075016
	FA-002	-327	-147	361718	3075016
	FA-003	-327	-147	361718	3075016
	FA-004	-59	-145	361800	3075017
	FA-005	-46	-154	361804	3075014
	FA-006	478	157	361964	3075109
	FA-007	475	132	361963	3075101
	FA-008	475	132	361963	3075101
Gypsum	GH-001	1,033	48	362133	3075076
	GH-002	967	-10	362113	3075058
	GH-003	967	-10	362113	3075058
	GH-004a	1,095	-14	362152	3075057
	GH-004b	1,095	-14	362152	3075057
	GH-007	860	-600	362080	3074878
	GH-008	860	-5,600	362080	3073354
	GH-009	2,360	-5,700	362538	3073323
	GH-010	2,360	-5,700	362538	3073323
	GH-011	2,360	-5,825	362538	3073285
	GH-012	2,360	-5,825	362538	3073285
	GH-013	2,360	-5,825	362538	3073285
	GH-014	2,360	-5,825	362538	3073285
	GH-015	2,360	-5,700	362538	3073323
	Limestone	LSH-001	715	-305	362036
LSH-002		1,289	-267	362211	3074980
LSH-003		1,245	-137	362198	3075019
LSH-004/005		790	-106	362059	3075029
LSH-006/007		790	-134	362059	3075020
LSH-008		790	-159	362059	3075013

Note: UTM coordinates for Unit 3 stack in meters are Zone 17, 361818 E., 3075061 N.

air observations. These data were obtained from the National Climatic Data Center (NCDC) for January 1, 1992, through December 31, 1996. Missing data were replaced following EPA guidance. The data were then prepared for use in ISCST3 using the RAMMET preprocessor. These same data were previously used for the Big Bend Station Title V dispersion modeling analysis.

Two other surface weather observation stations were evaluated for possible use in ISCST but were subsequently rejected. Surface data from Tampa International Airport (TPA) are available through 1994. In 1995, the TPA observation station was automated and sky cover observations were terminated. Because sky cover is a required element for ISCST3, the post-1994 TPA data unsuitable for use. Surface data from McDill Air Force Base is available through 1992. After 1992, surface observations become more sporadic and no longer meet EPA criteria for data recovery. Because SPG appropriate data are available through 1996, SPG surface data were selected for use over TPA and MAC surface data, consistent with EPA guidance.

### **DISPERSION MODELING RESULTS**

The Big Bend Station dispersion modeling results are presented in Tables 13 through 16. During the period January 1, 1992 through December 31, 1996, no modeled exceedances of the national or Florida AAQS were recorded. The dispersion model input and output files are provided in electronic format on the enclosed floppy disk.

# Scenario 1

80% reduction

New

		SER	SH	ST	SV	SD
S1	B12	830 $\mu\text{g s}^{-1}$	149.4	326	18.3	8.8
1,2,4 S	B3	2799.8	149.4	426	15.6	7.3
3 not scrubbed	B4	447.4	149.4	326	23.87	7.3
	CT1	11.0	10.7	817	28.0	3.4
Total 4710 $\mu\text{g s}^{-1}$ / 6879	CT23	122.0	22.9	771	35.4	5.1

39% reduction

The file from Scenario 1 that is most important is BBS194X.BST  
 BPIP file is BBS194X.PIP  
 BBS194X.DTA

# Scenario 2 32% reduction

The modeling results show that

Modeled maximum <sup>predicted</sup> ambient  $\text{SO}_2$  24 hour impacts for Scenarios 1, 2 and 4 are extremely close to the <sup>24 hour  $\text{SO}_2$</sup>  AAQS of  $260 \mu\text{g}/\text{m}^3$ . These predicted maximum impacts are much higher than those <sup>submitted</sup> for the base case in ~~the~~ the Title V application. Only TECO's sources were modeled <sup>on</sup> for this project. The consequence of adding background concentration

Table 13. Big Bend Station - Modeled Ambient SO<sub>2</sub> Impacts

Scenario	Averaging Period	Modeled Ambient Impact (µg/m <sup>3</sup> )					Ambient Air Quality Standard (µg/m <sup>3</sup> )	
		1992	1993	1994	1995	1996	National	Florida
Scenario 1 830g/ls	Annual	15.2	17.7	14.7	12.9	17.4	80	60
	H24	336.4	318.3	338.5	213.7	251.5	None	None
	H2H24	237.7	241.8	256.8	209.9	230.0	365	260
	H3	956.0	885.1	809.4	995.9	929.7	None	None
	H2H3	732.1	771.2	674.5	635.2	746.2	1,300	1,300
Scenario 2	Annual	13.5	14.9	13.3	15.3	14.6	80	60
	H24	261.8	246.2	262.4	264.4	259.2	None	None
	H2H24	185.6	188.8	202.1	256.4	225.0	365	260
	H3	742.5	692.9	687.4	970.2	840.3	None	None
	H2H3	592.0	596.0	582.2	735.8	656.6	1,300	1,300
Scenario 3	Annual	9.9	11.3	8.2	9.0	8.8	80	60
	H24	144.0	132.8	150.0	124.0	116.9	None	None
	H2H24	104.8	132.3	114.0	123.8	108.8	365	260
	H3	398.1	424.1	411.2	685.9	471.3	None	None
	H2H3	346.1	356.2	388.5	357.4	383.6	1,300	1,300
Scenario 4	Annual	14.6	11.4	14.5	16.4	14.9	80	60
	H24	230.3	220.8	247.9	268.6	231.4	None	None
	H2H24	189.1	143.7	161.0	253.2	220.5	365	260
	H3	686.3	682.0	611.7	965.9	826.6	None	None
	H2H3	610.2	667.7	575.5	711.6	648.5	1,300	1,300

Notes: H24 = Highest 24-hour average.  
H2H24 = Highest second-highest 24-hour average.  
H3 = Highest 3-hour average.  
H2H3 = Highest second-highest 3-hour average.

SO<sub>2</sub>  
Annual 16 60  
24hr 257 260  
3hr 771 1300

area wide emission reduction



Scenario 2

1970  
1971  
1972  
1973  
1974  
1975  
1976  
1977  
1978  
1979  
1980  
1981  
1982  
1983  
1984  
1985  
1986  
1987  
1988  
1989  
1990  
1991  
1992  
1993  
1994  
1995  
1996  
1997  
1998  
1999  
2000  
2001  
2002  
2003  
2004  
2005  
2006  
2007  
2008  
2009  
2010  
2011  
2012  
2013  
2014  
2015  
2016  
2017  
2018  
2019  
2020  
2021  
2022  
2023  
2024  
2025  
2026  
2027  
2028  
2029  
2030

**Table 14. Big Bend Station - Modeled Ambient NO<sub>x</sub> Impacts**

Scenario	Averaging Period	Modeled Ambient Impact (µg/m <sup>3</sup> )					Ambient Air Quality Standard (µg/m <sup>3</sup> )	
		1992	1993	1994	1995	1996	National	Florida
		Scenario 1	Annual	9.7	10.9	8.9	10.4	8.6
Scenario 2	Annual	11.6	10.9	11.8	13.0	11.2	100	100
Scenario 3	Annual	10.9	12.3	10.4	12.1	9.9	100	100
Scenario 4	Annual	13.6	12.3	13.7	15.2	12.4	100	100

Notes: H24 = Highest 24-hour average.  
 H2H24 = Highest second-highest 24-hour average.  
 H3 = Highest 3-hour average.  
 H2H3 = Highest second-highest 3-hour average.

NO<sub>2</sub>  
 Annual 15

**Table 15. Big Bend Station - Modeled Ambient PM<sub>10</sub> Impacts**

Scenario	Averaging Period	Modeled Ambient Impact ( $\mu\text{g}/\text{m}^3$ )					Ambient Air Quality Standard ( $\mu\text{g}/\text{m}^3$ )	
		1992	1993	1994	1995	1996	National	Florida
Scenario 1	Annual	12.9	14.8	16.6	13.5	14.6	50	50
	H24	120.0	108.4	107.4	81.2	129.3	None	None
	H2H24	64.1	76.6	101.0	59.6	77.1	150	150
Scenario 2	Annual	12.9 ✓	14.8	16.6	13.5	14.6	50	50
	H24	120.0 ✓	108.4	107.4	81.2	129.3	None	None
	H2H24	64.1 ✓	76.7	101.0	59.6	77.1	150	150
Scenario 3	Annual	12.9	14.8	16.6	13.5	14.6	50	50
	H24	120.0	108.4	107.6	81.2	129.3	None	None
	H2H24	64.1	76.9	101.2	59.7	77.1	150	150
Scenario 4	Annual	12.9	14.8	16.6	13.5	14.7	50	50
	H24	120.0	108.4	107.6	81.2	129.3	None	None
	H2H24	64.1	76.9	101.2	59.8	77.1	150	150

Notes: H24 = Highest 24-hour average.  
H2H24 = Highest second-highest 24-hour average.  
H3 = Highest 3-hour average.  
H2H3 = Highest second-highest 3-hour average.

PM<sub>10</sub>  
Annual 17 50  
24hr 101 150

**Table 16. Big Bend Station - Modeled Ambient CO Impacts**

Scenario	Averaging Period	Modeled Ambient Impact ( $\mu\text{g}/\text{m}^3$ )					Ambient Air Quality Standard ( $\mu\text{g}/\text{m}^3$ )	
		1992	1993	1994	1995	1996	National	Florida
Scenario 1	H8	7.8 <sup>8</sup>	9.4	10.1	9.3	8.3	None	None
	H2H8	7.5 ✓	8.9	7.7	7.6	6.8	10,000	10,000
	H1	30.4	30.1	30.0	31.0	31.1	None	None
	H2H1	29.3	29.7	27.7	27.3	30.4	40,000	40,000
Scenario 2	H8	7.8	9.4	10.1	9.3	8.3	None	None
	H2H8	7.5	8.9	7.7	7.6	6.8	10,000	10,000
	H1	30.4	30.1	30.0	31.0	31.1	None	None
	H2H1	29.3	29.7	27.7	27.3	30.4	40,000	40,000
Scenario 3	H8	9.2	10.5	10.8	10.2	10.3	None	None
	H2H8	7.8	9.5	8.4	9.1	8.1	10,000	10,000
	H1	34.4	35.2	33.1	36.5	35.7	None	None
	H2H1	30.5	33.9	32.3	32.0	34.4	40,000	40,000
Scenario 4	H8	9.5	10.5	10.8	10.1	10.3	None	None
	H2H8	7.7	9.5	8.4	9.8	8.1	10,000	10,000
	H1	34.4	34.2	33.1	36.5	35.7	None	None
	H2H1	30.5	33.9	32.3	32.0	34.4	40,000	40,000

Notes: H24 = Highest 24-hour average.  
 H2H24 = Highest second-highest 24-hour average.  
 H3 = Highest 3-hour average.  
 H2H3 = Highest second-highest 3-hour average.

CO

8hr	10	10,000
1hr	37	40,000

**DOCUMENT III.L.2**

**FUEL ANALYSES**

## EVALUATION COAL

The following coal and coke analyses shall be used to develop contractor's material balances, operating parameters, and base performance guarantees. Contractor shall assume that evaluation coal shall consist of 85 percent (by weight) of the average coal and be guaranteed 15% (by weight) of the average coke. The FGDS shall also perform for the range of coals and cokes identified.

### Approximate Fuel Quality Parameters

	Range	Average
<u>Coal</u>		
Higher heating value	10,880—12,000	11,575 Btu/lb
Sulfur, as received	2.35—3.10	2.8%
Moisture	10.0—14.4	12.5%
Ash	5.5—12.3	7.5%
Chlorine	0.02—0.35	0.15%
<u>Pet Coke (up to 20% of burn)</u>		
Higher heating value	13,672—14,374	14,063 Btu/lb
Sulfur, as received	4.6—5.2	4.85%
Moisture	7.0—11.7	8.87%
Ash	0.3—1.0	0.50%
Chlorine	NA	NA
<u>Coal Ash Analysis</u>		
Aluminum oxide, Al <sub>2</sub> O <sub>3</sub>		18.00%
Calcium oxide		5.00%
Iron oxide, Fe <sub>2</sub> O <sub>3</sub>		19.00%
Magnesium oxide, MgO		1.00%
Phosphorus, P <sub>2</sub> O <sub>5</sub>		0.15%
Silicon dioxide, SiO <sub>2</sub>		48.00%
Titanium dioxide		1.00%
Sodium oxide, Na <sub>2</sub> O		0.65%
Potassium oxide		2.30%
Undetermined		1.60%
Sulfur		1.40%
<u>Pet Coke Ash Analysis (typical)</u>		
Silicon dioxide, SiO <sub>2</sub>		32.00%
Iron oxide, Fe <sub>2</sub> O <sub>3</sub>		8.00%
Vanadium pentoxide, V <sub>2</sub> O <sub>5</sub>		32.00%
Nickel oxide, NiO		8.00%
Aluminum oxide, Al <sub>2</sub> O <sub>3</sub>		10.00%
Calcium oxide		2.00%

## EXHIBIT A

### No. 2 Oil

Parameters	Specification Minimum	Specification Maximum	ASTM Test Method
Heat content, Btu/gal	137,000	—	D-240
Sulfur, % weight	—	0.5	D-1552
Viscosity, SUS @ 100°F	32.6	40.5	D-445/2161
Ash, % weight	—	0.01	D-482
Water & sediment, % weight	—	0.05	D-2709
Flash point, °F	100	—	D-93`
API gravity @ 60°F	30	—	—
Specific gravity @ 60°F	—	0.876	D-287
Vanadium, PPM	—	0.5	D-3605-91
Sodium	—	0.5	D-3605-91

Latest ASTM or equivalent revision shall apply in reference to the above ASTM or equivalent Test Method.

**DOCUMENT III.L.3**

**DETAILED DESCRIPTION  
OF CONTROL EQUIPMENT**



## ELECTROSTATIC PRECIPITATOR

<b>Emission Unit:</b>	Unit #1
<b>Emission Point ID No.:</b>	CS-001a, 001b
<b>Manufacturer:</b>	Joy Western
<b>Model No.:</b>	NA
<b>Control Efficiency (%):</b>	99.7
<b>Pressure Drop (in H<sub>2</sub>O), operating:</b>	<1.0
<b>Temperature, operating (°F):</b>	330
<b>Temperature, design (°F):</b>	298
<b>Inlet Air Flow Rate (acfm):</b>	1,408,000
<b>Collection Plate Area (ft<sup>2</sup>):</b>	394,600
<b>Plate Cleaning Procedures:</b>	Rappers (Magnetic Impact Type)

## ELECTROSTATIC PRECIPITATOR

<b>Emission Unit:</b>	Unit #2
<b>Emission Point ID No.:</b>	CS-001a, 001b
<b>Manufacturer:</b>	Joy Western
<b>Model No.:</b>	NA
<b>Control Efficiency (%):</b>	99.7
<b>Pressure Drop (in H<sub>2</sub>O), operating:</b>	<1.0
<b>Temperature, operating (°F):</b>	330
<b>Temperature, design (°F):</b>	301
<b>Inlet Air Flow Rate (acfm):</b>	1,312,000
<b>Collection Plate Area (ft<sup>2</sup>):</b>	466,600
<b>Plate Cleaning Procedures:</b>	Rappers (Magnetic Impact Type)

## FABRIC FILTER

<b>Emission Unit:</b>	Limestone Handling Railcar/Truck Unloading
<b>Emission Point ID No.:</b>	LSH-001
<b>Manufacturer:</b>	Mikro-Pulsaire
<b>Model No.:</b>	400S12TR
<b>Inlet Temp. (°F):</b>	Ambient
<b>Outlet Temp. (°F):</b>	Ambient
<b>Inlet Air Flow Rate (dscfm):</b>	33,600
<b>Air to Cloth Ratio:</b>	5.9:1
<b>Filter Surface Area (ft<sup>2</sup>):</b>	5,648
<b>Cleaning Procedures:</b>	Pulse jet

## FABRIC FILTER

<b>Emission Unit:</b>	Limestone Handling Conveyor LB to LC
<b>Emission Point ID No.:</b>	LSH-002
<b>Manufacturer:</b>	Sternvent
<b>Model No.:</b>	DKED18003
<b>Inlet Temp. (°F):</b>	Ambient
<b>Outlet Temp. (°F):</b>	Ambient
<b>Inlet Air Flow Rate (dscfm):</b>	800
<b>Air to Cloth Ratio:</b>	4.4:1
<b>Filter Surface Area (ft<sup>2</sup>):</b>	180
<b>Cleaning Procedures:</b>	Automatic shaker

## FABRIC FILTER

<b>Emission Unit:</b>	Limestone Handling Conveyor LB to LC
<b>Emission Point ID No.:</b>	LSH-003
<b>Manufacturer:</b>	Sternvent
<b>Model No.:</b>	DKED18003
<b>Inlet Temp. (°F):</b>	Ambient
<b>Outlet Temp. (°F):</b>	Ambient
<b>Inlet Air Flow Rate (dscfm):</b>	800
<b>Air to Cloth Ratio:</b>	4.4:1
<b>Filter Surface Area (ft<sup>2</sup>):</b>	180
<b>Cleaning Procedures:</b>	Automatic shaker

## FABRIC FILTER

<b>Emission Unit:</b>	Limestone Handling Conveyor LE to Storage Silo A Conveyor LE to Conveyor LF
<b>Emission Point ID No.:</b>	LSH-004, 005
<b>Manufacturer:</b>	Flex Kleen
<b>Model No.:</b>	58-BVBC-36-IIG
<b>Inlet Temp. (°F):</b>	Ambient
<b>Outlet Temp. (°F):</b>	Ambient
<b>Inlet Air Flow Rate (dscfm):</b>	552
<b>Air to Cloth Ratio:</b>	2.1:1
<b>Filter Surface Area (ft<sup>2</sup>):</b>	259
<b>Cleaning Procedures:</b>	Pulse jet

## FABRIC FILTER

<b>Emission Unit:</b>	Limestone Handling Conveyor LF to Storage Silo B Conveyor LF to Conveyor LG
<b>Emission Point ID No.:</b>	LSH-006, 007
<b>Manufacturer:</b>	Flex Kleen
<b>Model No.:</b>	58-BVBC-36-IIG
<b>Inlet Temp. (°F):</b>	Ambient
<b>Outlet Temp. (°F):</b>	Ambient
<b>Inlet Air Flow Rate (dscfm):</b>	552
<b>Air to Cloth Ratio:</b>	2.1:1
<b>Filter Surface Area (ft<sup>2</sup>):</b>	259
<b>Cleaning Procedures:</b>	Pulse jet

## FABRIC FILTER

<b>Emission Unit:</b>	Limestone Handling Conveyor LG to Storage Silo C
<b>Emission Point ID No.:</b>	LSH-008
<b>Manufacturer:</b>	To be determined
<b>Model No.:</b>	To be determined
<b>Inlet Temp. (°F):</b>	Ambient
<b>Outlet Temp. (°F):</b>	Ambient
<b>Inlet Air Flow Rate (dscfm):</b>	300
<b>Air to Cloth Ratio:</b>	6:1
<b>Filter Surface Area (ft<sup>2</sup>):</b>	To be determined
<b>Cleaning Procedures:</b>	Pulse jet



## FLUE GAS DESULFURIZATION (FGD)

<b>Emission Unit:</b>	Unit #1, #2
<b>Emission Point ID No.:</b>	CS-001b
<b>Manufacturer:</b>	Wheelabrator
<b>Description of Control Equipment:</b>	Single absorber module
<b>Inlet Temp. (°F):</b>	300
<b>Outlet Temp. (°F):</b>	127
<b>Inlet Air Flow Rate (acfm):</b>	2,820,000
<b>Additive Liquid Scrubbing Medium:</b>	Limestone Slurry
<b>Total Liquid Injection Rate (gpm):</b>	49,000 per each of four spray heads

**DOCUMENT III.L.4**

**DESCRIPTION OF STACK SAMPLING FACILITIES**

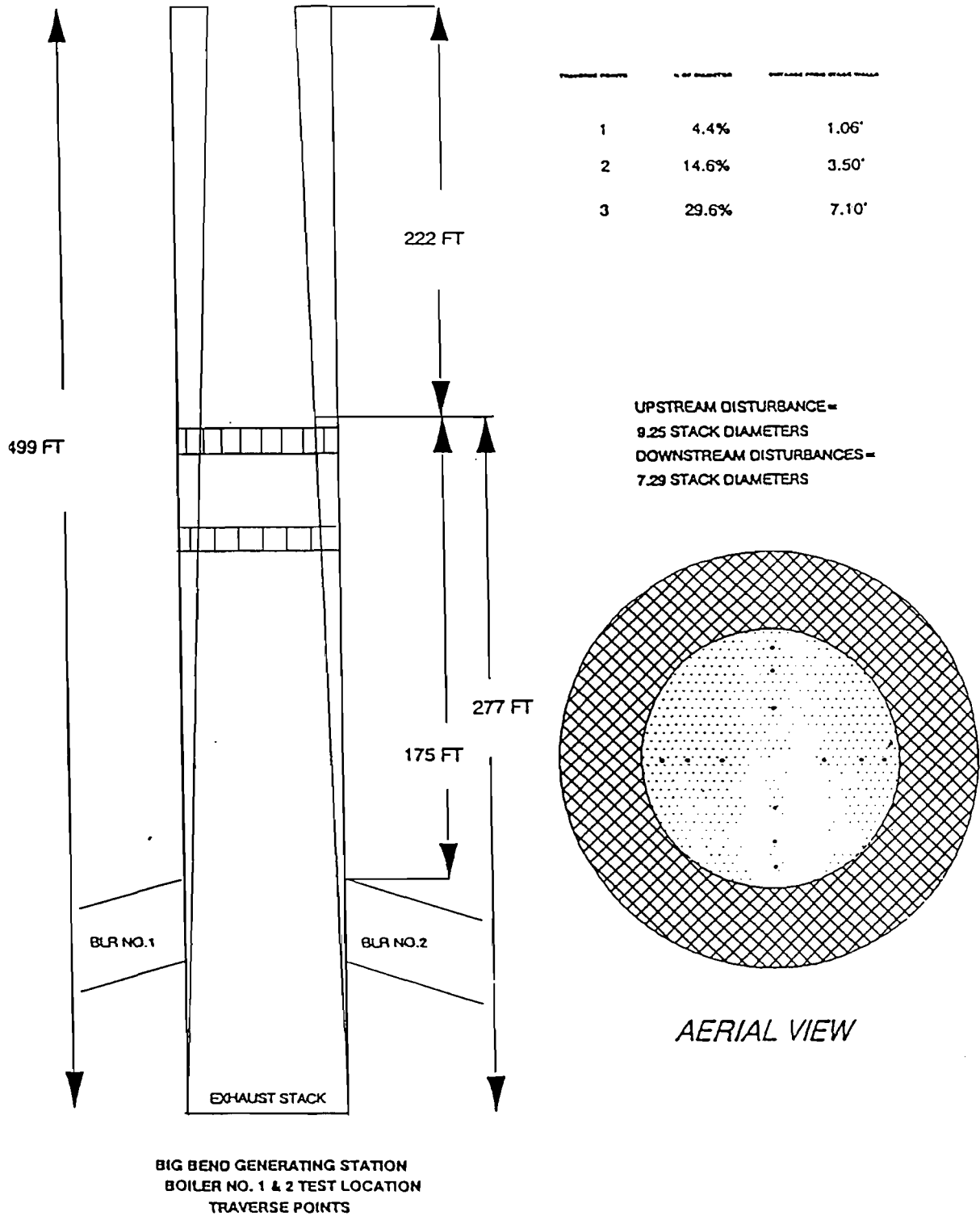

FIGURE 1.  
BIG BEND STATION UNIT NOS. 1 AND 2,  
STACK CS-001a TRAVERSE POINTS

Source: ECT, 1998.



The stack sampling facilities are currently being designed for Unit Nos. 1 and 2 Stack CS-001b. Stack sampling facilities details will be provided to the Florida Department of Environmental Protection before the flue gas desulfurization system becomes operational.

**DOCUMENT III.L.7**

**OPERATION AND MAINTENANCE PLAN**

E.U.1., UNIT NO. 1—SOLID FUEL-FIRED STEAM GENERATOR  
OPERATION AND MAINTENANCE FOR PARTICULATE CONTROL

A. Process System Performance Parameters:

1. Design fuel consumption rate at maximum continuous rating: 183.5 tons fuel/hour at 11,000 Btu/lb
2. Operating pressure: 2,400 psi
3. Operating temperature: 1,000 °F
4. Maximum design steam capacity: 3,000,000 lbs/hr

B. Particulate Control Equipment Data:

1. Control equipment designator: electrostatic precipitator
2. Electrostatic precipitator manufacturer: Joy Western
3. Design flow rate: 1,408,000 ACFM
4. Primary voltage: 400 volts
5. Primary current: 245 amps
6. Secondary voltage: 55 kilovolts
7. Secondary current: 1,250 milliamps
8. Design efficiency: 99.7 percent
9. Pressure drop: <1.0 inches H<sub>2</sub>O (average)
10. Rapper frequency: 1/1.5 min. - 1/4.0 min. (average)
11. Rapper duration: impact
12. Gas temperature: 330± 55°F (average)

- C. The following observations, checks, and operations apply to this source and shall be conducted on the schedule specified:

Continuously Monitored and Recorded

Visible emissions (continuous opacity monitor [COM])

Steam pressure

Steam temperature

Steam flow

Daily Recorded and Inspected

Electrostatic Precipitator

Primary current

Secondary voltage

Secondary current

Monthly Recorded and Inspected

Fuel input (recorded)

Inspect insulator compartment heaters/blowers. Service as needed.

Observe operation of all rapper and transformer/rectifier controls. Service as needed.

- D. Records of inspections, maintenance, and performance parameters shall be retained for a minimum of 2 years and shall be made available to the Florida Department of Environmental Protection or the Environmental Protection Commission of Hillsborough County upon request.

E.U.2., UNIT NO. 2—SOLID FUEL-FIRED STEAM GENERATOR  
OPERATION AND MAINTENANCE FOR PARTICULATE CONTROL

A. Process System Performance Parameters:

1. Design fuel consumption rate at maximum continuous rating: 182.1 tons fuel/hour at 11,000 Btu/lb
2. Operating pressure: 2,400 psi
3. Operating temperature: 1,000 °F
4. Maximum design steam capacity: 3,000,000 lbs/hr.

B. Particulate Control Equipment Data:

1. Control equipment designator: electrostatic precipitator
2. Electrostatic precipitator manufacturer: Joy Western
3. Design flow rate: 1,312,000 ACFM
4. Primary voltage: 400 volts
5. Primary current: 257 amps
6. Secondary voltage: 45 kilovolts
7. Secondary current: 1,600 milliamps
8. Design efficiency: 99.7 percent
9. Pressure drop: <1.0 inches H<sub>2</sub>O (average)
10. Rapper frequency: 1/1.5 min. - 1/4.0 min. (average)
11. Rapper duration: impact
12. Gas temperature: 330± 55°F (average)

- C. The following observations, checks, and operations apply to this source and shall be conducted on the schedule specified:

Continuously Monitored and Recorded

Visible emissions (COM)

Steam pressure

Steam temperature

Steam flow



Daily Recorded and Inspected

Electrostatic Precipitator

Primary current

Secondary voltage

Secondary current

Monthly Recorded or Inspection/Maintenance

Fuel input (recorded)

Inspect insulator compartment heaters/blowers. Service as needed.

Observe operation of all rapper and transformer/rectifier controls. Service as needed.

- D. Records of inspections, maintenance, and performance parameters shall be retained for a minimum of 2 years and shall be made available to the Florida Department of Environmental Protection or the Environmental Protection Commission of Hillsborough County upon request.

**APPENDIX**

**EMISSION CALCULATIONS**

<b>EMISSION INVENTORY WORKSHEET</b>					<b>CS-001a</b>
<b>Tampa Electric Company - Big Bend Station</b>					
<i>EMISSION SOURCE TYPE</i>					
<b>COAL COMBUSTION - CRITERIA POLLUTANTS</b>				<b>Figure:</b>	
<i>FACILITY AND SOURCE DESCRIPTION</i>					
<b>Emission Source Description:</b>		Unit No. 1, Pulverized Fuel - Wet Bottom			
<b>Emission Control Method(s)/ID No.(s):</b>		Electrostatic Precipitator (ESP), Flue Gas Conditioning			
<b>Emission Point ID:</b>		CS-001a			
<i>EMISSION ESTIMATION EQUATIONS</i>					
<b>Emission (lb/hr) = Heat Input (MMBtu/hr) x Pollutant Emission Rate (lb/MMBtu)</b>					
<b>Emission (tpy) = Heat Input (MMBtu/hr) x Pollutant Emission rate (lb/MMBtu) x Operating Period (hr/yr) x (1 ton/2,000 lb)</b>					
Source: ECT, 1995.					
<i>INPUT DATA AND EMISSIONS CALCULATIONS</i>					
<b>Operating Hours:</b>		24 Hrs/Day	7 Days/Wk	8,760 Hrs/Yr	
Criteria Pollutant	Maximum Heat Input (MMBtu/hr)	Pollutant Emission Factor (lb/MMBtu)	Pollutant Emission Rate		
			(lb/hr)	(tpy)	
SO <sub>2</sub>	4,037	6.500	26,240.5	114,933.4	
NO <sub>x</sub>	4,037	1.545	6,239.0	27,326.8	
PM/PM <sub>10</sub> <sup>1</sup>	4,037	0.300	1,211.1	2,210.3	
CO	4,037	0.023	91.8	401.9	
VOC <sup>2</sup>	4,037	0.00182	7.3	32.1	
<i>SOURCES OF INPUT DATA</i>					
Variable		Data Source			
Operating Hours		TEC, 1998.			
Maximum Heat Input		TEC, 1998.			
Emission Factors: SO <sub>2</sub> , NO <sub>x</sub> , and CO <sup>3</sup>		Table 1.1-3., Section 1.1, AP-42, January 1995.			
Emission Factor: PM/PM <sub>10</sub>		TEC, 1998. Design data.			
Emission Factor: VOC <sup>3</sup>		Table 1.1-18., Section 1.1, AP-42, January 1995.			
<i>NOTES AND OBSERVATIONS</i>					
<sup>1</sup> Annual PM/PM <sub>10</sub> emission rate based on 0.3 lb/MMBtu for 3 hr/day (soot blowing) and 0.1 lb/MMBtu for 21 hr/day.					
<sup>2</sup> VOC emission rate represents non-methane total organic compounds (NMTOC).					
<sup>3</sup> Emission factors based on coal heat content of 11,000 Btu/lb.					
<i>DATA CONTROL</i>					
Data Collected by:	A. Trbovich		Date:	4/2/98	
Evaluated by:	A. Trbovich		Date:	4/2/98	
Data Entered by:	A. Trbovich		Date:	4/2/98	
Reviewed by:	G. Nelson		Date:	6/12/98	

## EMISSION INVENTORY WORKSHEET

Tampa Electric Company - Big Bend Station

CS-001b

### EMISSION SOURCE TYPE

COAL COMBUSTION - CRITERIA POLLUTANTS

Figure:

### FACILITY AND SOURCE DESCRIPTION

Emission Source Description: Unit No. 2, Pulverized Fuel - Wet Bottom

Emission Control Method(s)/ID No.(s): Electrostatic Precipitator (ESP), Flue Gas Desulfurization (FGD)

Emission Point ID: CS-001b

### EMISSION ESTIMATION EQUATIONS

Emission (lb/hr) = Heat Input (MMBtu/hr) x Pollutant Emission Rate (lb/MMBtu)

Emission (tpy) = Heat Input (MMBtu/hr) x Pollutant Emission rate (lb/MMBtu) x Operating Period (hr/yr) x (1 ton/2,000 lb)

Source: ECT, 1995.

### INPUT DATA AND EMISSIONS CALCULATIONS

Operating Hours: 24 Hrs/Day 7 Days/Wk 8,760 Hrs/Yr

Criteria Pollutant	Maximum Heat Input (MMBtu/hr)	Pollutant Emission Factor (lb/MMBtu)	Pollutant Emission Rate	
			(lb/hr)	(tpy)
SO <sub>2</sub>	3,996	0.82	3,276.7	14,352.0
NO <sub>x</sub>	3,996	1.545	6,175.6	27,049.3
PM/PM <sub>10</sub> <sup>1</sup>	3,996	0.300	1,198.8	2,187.8
CO	3,996	0.023	90.8	397.8
VOC <sup>2</sup>	3,996	0.00182	7.3	31.8

### SOURCES OF INPUT DATA

Variable	Data Source
Operating Hours	TEC, 1998.
Maximum Heat Input	TEC, 1998.
Emission Factors: NO <sub>x</sub> and CO <sup>3</sup>	Table 1.1-3., Section 1.1, AP-42, January 1995.
Emission Factor: SO <sub>2</sub>	TEC, 1998. Design data.
Emission Factor: PM/PM <sub>10</sub>	TEC, 1998. Design data.
Emission Factor: VOC <sup>3</sup>	Table 1.1-18., Section 1.1, AP-42, January 1995.

### NOTES AND OBSERVATIONS

<sup>1</sup>Annual PM/PM<sub>10</sub> emission rate based on 0.3 lb/MMBtu for 3 hr/day (soot blowing) and 0.1 lb/MMBtu for 21 hr/day.

<sup>2</sup>VOC emission rate represents non-methane total organic compounds (NMTOC).

<sup>3</sup>Emission factors based on coal heat content of 11,000 Btu/lb.

### DATA CONTROL

Data Collected by:	A. Trbovich	Date:	4/2/98
Evaluated by:	A. Trbovich	Date:	4/2/98
Data Entered by:	A. Trbovich	Date:	4/2/98
Reviewed by:	G. Nelson	Date:	6/12/98

# EMISSION INVENTORY WORKSHEET

Tampa Electric Company - Big Bend Station

CS-001a

## EMISSION SOURCE TYPE

COAL COMBUSTION - CRITERIA POLLUTANTS

Figure:

## FACILITY AND SOURCE DESCRIPTION

Emission Source Description: Unit No. 2, Pulverized Fuel - Wet Bottom  
 Emission Control Method(s)/ID No.(s): Electrostatic Precipitator (ESP), Flue Gas Conditioning+C34  
 Emission Point ID: CS-001a

## EMISSION ESTIMATION EQUATIONS

Emission (lb/hr) = Heat Input (MMBtu/hr) x Pollutant Emission Rate (lb/MMBtu)  
 Emission (tpy) = Heat Input (MMBtu/hr) x Pollutant Emission rate (lb/MMBtu) x Operating Period (hr/yr) x (1 ton/2,000 lb)

Source: ECT, 1995.

## INPUT DATA AND EMISSIONS CALCULATIONS

Operating Hours:	24 Hrs/Day	7 Days/Wk	8,760 Hrs/Yr	
Criteria Pollutant	Maximum Heat Input (MMBtu/hr)	Pollutant Emission Factor (lb/MMBtu)	Pollutant Emission Rate	
			(lb/hr)	(tpy)
SO <sub>2</sub>	3,996	6.500	25,974.0	113,766.1
NO <sub>x</sub>	3,996	1.545	6,175.6	27,049.3
PM/PM <sub>10</sub> <sup>1</sup>	3,996	0.300	1,198.8	2,187.8
CO	3,996	0.023	90.8	397.8
VOC <sup>2</sup>	3,996	0.00182	7.3	31.8

## SOURCES OF INPUT DATA

Variable	Data Source
Operating Hours	TEC, 1998.
Maximum Heat Input	TEC, 1998.
Emission Factors: SO <sub>2</sub> , NO <sub>x</sub> , and CO <sup>3</sup>	Table 1.1-3., Section 1.1, AP-42, January 1995.
Emission Factor: PM/PM <sub>10</sub>	TEC, 1998. Design data.
Emission Factor: VOC <sup>3</sup>	Table 1.1-18., Section 1.1, AP-42, January 1995.

## NOTES AND OBSERVATIONS

<sup>1</sup>Annual PM/PM<sub>10</sub> emission rate based on 0.3 lb/MMBtu for 3 hr/day (soot blowing) and 0.1 lb/MMBtu for 21 hr/day.  
<sup>2</sup>VOC emission rate represents non-methane total organic compounds (NMTOC).  
<sup>3</sup>Emission factors based on coal heat content of 11,000 Btu/lb.

## DATA CONTROL

Data Collected by:	A. Trbovich	Date:	4/2/98
Evaluated by:	A. Trbovich	Date:	4/2/98
Data Entered by:	A. Trbovich	Date:	4/2/98
Reviewed by:	G. Nelson	Date:	6/12/98

# EMISSION INVENTORY WORKSHEET

Tampa Electric Company - Big Bend Station

CS-001b

## EMISSION SOURCE TYPE

COAL COMBUSTION - CRITERIA POLLUTANTS

Figure:

## FACILITY AND SOURCE DESCRIPTION

Emission Source Description: Unit No. 1, Pulverized Fuel - Wet Bottom

Emission Control Method(s)/ID No.(s): Electrostatic Precipitator (ESP), Flue Gas Desulfurization (FGD)

Emission Point ID: CS-001b

## EMISSION ESTIMATION EQUATIONS

Emission (lb/hr) = Heat Input (MMBtu/hr) x Pollutant Emission Rate (lb/MMBtu)

Emission (tpy) = Heat Input (MMBtu/hr) x Pollutant Emission rate (lb/MMBtu) x Operating Period (hr/yr) x (1 ton/2,000 lb)

Source: ECT, 1995.

## INPUT DATA AND EMISSIONS CALCULATIONS

Operating Hours: 24 Hrs/Day 7 Days/Wk 8,760 Hrs/Yr

Criteria Pollutant	Maximum Heat Input (MMBtu/hr)	Pollutant Emission Factor (lb/MMBtu)	Pollutant Emission Rate	
			(lb/hr)	(tpy)
SO <sub>2</sub>	4,037	0.82	3,310.3	14,499.3
NO <sub>x</sub>	4,037	1.545	6,239.0	27,326.8
PM/PM <sub>10</sub> <sup>1</sup>	4,037	0.300	1,211.1	2,210.3
CO	4,037	0.023	91.8	401.9
VOC <sup>2</sup>	4,037	0.00182	7.3	32.1

## SOURCES OF INPUT DATA

Variable	Data Source
Operating Hours	TEC, 1998.
Maximum Heat Input	TEC, 1998.
Emission Factors: NO <sub>x</sub> and CO <sup>3</sup>	Table 1.1-3., Section 1.1, AP-42, January 1995.
Emission Factor: SO <sub>2</sub>	TEC, 1998. Design data.
Emission Factor: PM/PM <sub>10</sub>	TEC, 1998. Design data.
Emission Factor: VOC <sup>3</sup>	Table 1.1-18., Section 1.1, AP-42, January 1995.

## NOTES AND OBSERVATIONS

<sup>1</sup>Annual PM/PM<sub>10</sub> emission rate based on 0.3 lb/MMBtu for 3 hr/day (soot blowing) and 0.1 lb/MMBtu for 21 hr/day.

<sup>2</sup>VOC emission rate represents non-methane total organic compounds (NMTOC).

<sup>3</sup>Emission factors based on coal heat content of 11,000 Btu/lb.

## DATA CONTROL

Data Collected by:	A. Trbovich	Date:	4/2/98
Evaluated by:	A. Trbovich	Date:	4/2/98
Data Entered by:	A. Trbovich	Date:	4/2/98
Reviewed by:	G. Nelson	Date:	6/12/98

<b>EMISSION INVENTORY WORKSHEET</b>					<b>LSH-001</b>
<b>EMISSION SOURCE TYPE</b>					
<b>MATERIAL TRANSFER - CONTROLLED EMISSION SOURCES</b>				<b>Figure:</b>	
<b>FACILITY AND SOURCE DESCRIPTION</b>					
<b>Emission Source Description:</b>		Limestone Handling - Railcar/Truck Unloading			
<b>Emission Control Method(s)/ID No.(s):</b>		Baghouse			
<b>Emission Point ID:</b>		LSH-001			
<b>EMISSION ESTIMATION EQUATIONS</b>					
Emission (lb/hr) = Flow Rate (scfm) x (1 lb/7,000 grain) x (60 min/hr)					
Emission (tpy) = Flow Rate (scfm) x 1 lb/7,000 grain) x (60 min/hr) x (1 ton/2,000 lb)					
Source: ECT, 1995.					
<b>INPUT DATA AND EMISSIONS CALCULATIONS</b>					
<b>Operating Hours:</b>		24 Hrs/Day		7 Days/Wk	
				8,760 Hrs/Yr	
Transfer Points Controlled By Common Control Device	Transfer Point ID No.	Exhaust Flow Rate (scfm)	Exit Grain Loading (gr/scf)	Potential PM/PM <sub>10</sub> Emission Rates	
				(lb/hr)	(tpy)
Railcar/Truck Unloading to Hoppers	LS-T1	33,600	0.002	0.58	2.52
West Hopper to Conveyor LA1	LS-T2				
East Hopper to Conveyor LA2	LS-T3				
Conveyors LA1 and LA2 to Conveyor LA	LS-T4				
<b>SOURCES OF INPUT DATA</b>					
Variable	Data Source				
Operating Hours	TEC, 1998.				
Exhaust Flow Rate	TEC, 1998.				
Exit Grain Loading	ECT, 1998. Estimate based on high moisture content of limestone.				
<b>NOTES AND OBSERVATIONS</b>					
<b>DATA CONTROL</b>					
<b>Data Collected by:</b>	A. Trbovich			<b>Date:</b>	5/19/98
<b>Evaluated by:</b>	A. Trbovich			<b>Date:</b>	5/19/98
<b>Data Entered by:</b>	A. Trbovich			<b>Date:</b>	5/19/98
<b>Reviewed by:</b>	G. Nelson			<b>Date:</b>	6/12/98

<b>EMISSION INVENTORY WORKSHEET</b>					<b>LSH-002</b>	
<b>Tampa Electric Company - Big Bend Station</b>						
<i>EMISSION SOURCE TYPE</i>						
<b>MATERIAL TRANSFER - CONTROLLED EMISSION SOURCES</b>					<b>Figure:</b>	
<i>FACILITY AND SOURCE DESCRIPTION</i>						
<b>Emission Source Description:</b>		Limestone Handling - Conveyor LB to Conveyor LC				
<b>Emission Control Method(s)/ID No.(s):</b>		Baghouse				
<b>Emission Point ID:</b>		LSH-002				
<i>EMISSION ESTIMATION EQUATIONS</i>						
Emission (lb/hr) = Flow Rate (scfm) x (1 lb/7,000 grain) x (60 min/hr)						
Emission (tpy) = Flow Rate (scfm) x 1 lb/7,000 grain x (60 min/hr) x (1 ton/2,000 lb)						
Source: ECT, 1995.						
<i>INPUT DATA AND EMISSIONS CALCULATIONS</i>						
<b>Operating Hours:</b>		24 Hrs/Day		7 Days/Wk	8,760 Hrs/Yr	
<b>Transfer Points Controlled By Common Control Device</b>		<b>Transfer Point ID No.</b>	<b>Exhaust Flow Rate (scfm)</b>	<b>Exit Grain Loading (gr/scf)</b>	<b>Potential PM/PM<sub>10</sub> Emission Rates</b>	
					(lb/hr)	(tpy)
Conveyor LB to Conveyor LC (two pickup points on drop)		LS-T5	800	0.002	0.01	0.06
<i>SOURCES OF INPUT DATA</i>						
<b>Variable</b>		<b>Data Source</b>				
Operating Hours		TEC, 1998.				
Exhaust Flow Rate		TEC, 1998.				
Exit Grain Loading		ECT, 1998. Estimate based on high moisture content of limestone.				
<i>NOTES AND OBSERVATIONS</i>						
<i>DATA CONTROL</i>						
<b>Data Collected by:</b>		A. Trbovich		<b>Date:</b> 5/19/98		
<b>Evaluated by:</b>		A. Trbovich		<b>Date:</b> 5/19/98		
<b>Data Entered by:</b>		A. Trbovich		<b>Date:</b> 5/19/98		
<b>Reviewed by:</b>		G. Nelson		<b>Date:</b> 6/12/98		



# EMISSION INVENTORY WORKSHEET

**Tampa Electric Company - Big Bend Station**

**LSH-003**

## EMISSION SOURCE TYPE

**MATERIAL TRANSFER - CONTROLLED EMISSION SOURCES**

Figure:

## FACILITY AND SOURCE DESCRIPTION

**Emission Source Description:** Limestone Handling - Conveyor LD to Conveyor LE

**Emission Control Method(s)/ID No.(s):** Baghouse

**Emission Point ID:** LSH-003

## EMISSION ESTIMATION EQUATIONS

**Emission (lb/hr) = Flow Rate (scfm) x (1 lb/7,000 grain) x (60 min/hr)**

**Emission (tpy) = Flow Rate (scfm) x 1 lb/7,000 grain) x (60 min/hr) x (1 ton/2,000 lb)**

Source: ECT, 1995.

## INPUT DATA AND EMISSIONS CALCULATIONS

**Operating Hours:** 24 Hrs/Day                      7 Days/Wk                      8,760 Hrs/Yr

Transfer Points Controlled By Common Control Device	Transfer Point ID No.	Exhaust Flow Rate (scfm)	Exit Grain Loading (gr/scf)	Potential PM/PM <sub>10</sub> Emission Rates	
				(lb/hr)	(tpy)
Conveyor LD to Conveyor LE (two pickup points on drop)	LS-T8	800	0.002	0.01	0.06

## SOURCES OF INPUT DATA

Variable	Data Source
Operating Hours	TEC, 1998.
Exhaust Flow Rate	TEC, 1998.
Exit Grain Loading	ECT, 1998. Estimate based on high moisture content of limestone.

## NOTES AND OBSERVATIONS

## DATA CONTROL

<b>Data Collected by:</b>	A. Trbovich	<b>Date:</b>	5/19/98
<b>Evaluated by:</b>	A. Trbovich	<b>Date:</b>	5/19/98
<b>Data Entered by:</b>	A. Trbovich	<b>Date:</b>	5/19/98
<b>Reviewed by:</b>	G. Nelson	<b>Date:</b>	6/12/98

<b>EMISSION INVENTORY WORKSHEET</b>					<b>LSH-004</b>	
<b>Tampa Electric Company - Big Bend Station</b>					<b>LSH-005</b>	
<b>EMISSION SOURCE TYPE</b>						
<b>MATERIAL TRANSFER - CONTROLLED EMISSION SOURCES</b>					<b>Figure:</b>	
<b>FACILITY AND SOURCE DESCRIPTION</b>						
<b>Emission Source Description:</b> Limestone Handling - Conveyor LE to Conveyor LF and Silo A						
<b>Emission Control Method(s)/ID No.(s):</b> Baghouse						
<b>Emission Point ID:</b> LSH-004, 005						
<b>EMISSION ESTIMATION EQUATIONS</b>						
<b>Emission (lb/hr) = Flow Rate (scfm) x (1 lb/7,000 grain) x (60 min/hr)</b>						
<b>Emission (tpy) = Flow Rate (scfm) x 1 lb/7,000 grain) x (60 min/hr) x (1 ton/2,000 lb)</b>						
Source: ECT, 1995.						
<b>INPUT DATA AND EMISSIONS CALCULATIONS</b>						
<b>Operating Hours:</b>		24 Hrs/Day		7 Days/Wk		8,760 Hrs/Yr
Transfer Points Controlled By Common Control Device	Transfer Point ID No.	Exhaust Flow Rate (scfm)	Exit Grain Loading (gr/scf)	Potential PM/PM <sub>10</sub> Emission Rates		
				(lb/hr)	(tpy)	
Conveyor LE to Conveyor LF	LS-T9	1,104	0.002	0.02	0.08	
Conveyor LF to Silo A	LS-T10					
<b>SOURCES OF INPUT DATA</b>						
Variable		Data Source				
Operating Hours		TEC, 1998.				
Exhaust Flow Rate		TEC, 1998.				
Exit Grain Loading		ECT, 1998. Estimate based on high moisture content of limestone.				
<b>NOTES AND OBSERVATIONS</b>						
<b>DATA CONTROL</b>						
<b>Data Collected by:</b>		A. Trbovich			<b>Date:</b> 5/19/98	
<b>Evaluated by:</b>		A. Trbovich			<b>Date:</b> 5/19/98	
<b>Data Entered by:</b>		A. Trbovich			<b>Date:</b> 5/19/98	
<b>Reviewed by:</b>		G. Nelson			<b>Date:</b> 6/12/98	

## EMISSION INVENTORY WORKSHEET

**Tampa Electric Company - Big Bend Station**

**LSH-006**

**LSH-007**

### EMISSION SOURCE TYPE

**MATERIAL TRANSFER - CONTROLLED EMISSION SOURCES**

Figure:

### FACILITY AND SOURCE DESCRIPTION

**Emission Source Description:** Limestone Handling - Conveyor LF to Conveyor LG and Silo B  
**Emission Control Method(s)/ID No.(s):** Baghouse  
**Emission Point ID:** LSH-006, 007

### EMISSION ESTIMATION EQUATIONS

**Emission (lb/hr) = Flow Rate (scfm) x (1 lb/7,000 grain) x (60 min/hr)**  
**Emission (tpy) = Flow Rate (scfm) x 1 lb/7,000 grain) x (60 min/hr) x (1 ton/2,000 lb)**

Source: ECT, 1995.

### INPUT DATA AND EMISSIONS CALCULATIONS

**Operating Hours:** 24 Hrs/Day                      7 Days/Wk                      8,760 Hrs/Yr

Transfer Points Controlled By Common Control Device	Transfer Point ID No.	Exhaust Flow Rate (scfm)	Exit Grain Loading (gr/scf)	Potential PM/PM <sub>10</sub> Emission Rates	
				(lb/hr)	(tpy)
Conveyor LF to Conveyor LG	LS-T11	1,104	0.002	0.02	0.08
Conveyor LF to Silo B	LS-T12				

### SOURCES OF INPUT DATA

Variable	Data Source
Operating Hours	TEC, 1998.
Exhaust Flow Rate	TEC, 1998.
Exit Grain Loading	ECT, 1998. Estimate based on high moisture content of limestone.

### NOTES AND OBSERVATIONS

### DATA CONTROL

<b>Data Collected by:</b>	A. Trbovich	<b>Date:</b>	5/19/98
<b>Evaluated by:</b>	A. Trbovich	<b>Date:</b>	5/19/98
<b>Data Entered by:</b>	A. Trbovich	<b>Date:</b>	5/19/98
<b>Reviewed by:</b>	G. Nelson	<b>Date:</b>	6/12/98

<b>EMISSION INVENTORY WORKSHEET</b>					<b>LSH-008</b>	
<b>Tampa Electric Company - Big Bend Station</b>						
<i>EMISSION SOURCE TYPE</i>						
<b>MATERIAL TRANSFER - CONTROLLED EMISSION SOURCES</b>					<b>Figure:</b>	
<i>FACILITY AND SOURCE DESCRIPTION</i>						
<b>Emission Source Description:</b>		Limestone Handling - Conveyor LG to Silo C				
<b>Emission Control Method(s)/ID No.(s):</b>		Baghouse				
<b>Emission Point ID:</b>		LSH-008				
<i>EMISSION ESTIMATION EQUATIONS</i>						
Emission (lb/hr) = Flow Rate (scfm) x (1 lb/7,000 grain) x (60 min/hr)						
Emission (tpy) = Flow Rate (scfm) x 1 lb/7,000 grain x (60 min/hr) x (1 ton/2,000 lb)						
Source: ECT, 1995.						
<i>INPUT DATA AND EMISSIONS CALCULATIONS</i>						
<b>Operating Hours:</b>		24 Hrs/Day		7 Days/Wk		8,760 Hrs/Yr
<b>Transfer Points Controlled By Common Control Device</b>	<b>Transfer Point ID No.</b>	<b>Exhaust Flow Rate (scfm)</b>	<b>Exit Grain Loading (gr/scf)</b>	<b>Potential PM/PM<sub>10</sub> Emission Rates</b>		
				<b>(lb/hr)</b>	<b>(tpy)</b>	
Conveyor LG to Silo C	LS-T13	300	0.002	0.01	0.02	
<i>SOURCES OF INPUT DATA</i>						
<b>Variable</b>		<b>Data Source</b>				
Operating Hours		TEC, 1998.				
Exhaust Flow Rate		REC, 1998.				
Exit Grain Loading		ECT, 1998. Estimate based on high moisture content of limestone.				
<i>NOTES AND OBSERVATIONS</i>						
<i>DATA CONTROL</i>						
<b>Data Collected by:</b>		A. Trbovich		<b>Date:</b>		5/25/98
<b>Evaluated by:</b>		A. Trbovich		<b>Date:</b>		5/25/98
<b>Data Entered by:</b>		A. Trbovich		<b>Date:</b>		5/25/98
<b>Reviewed by:</b>		G. Nelson		<b>Date:</b>		6/12/98

# EMISSION INVENTORY WORKSHEET

Tampa Electric Company – Big Bend Station

GH-001

## EMISSION SOURCE TYPE

**MATERIAL TRANSFER – FUGITIVE EMISSION SOURCES**

**Project:**

## FACILITY AND SOURCE DESCRIPTION

**Emission Source Description:** Gypsum Handling – Stacker Conveyor to North Stackout Pile

**Emission Control Method(s)/ID No.(s):** None

**Emission Point ID:** GH-001

**Transfer Point ID(s):**

## EMISSION ESTIMATION EQUATIONS

$$\text{Emission (lb/hr)} = 0.0011 \times \text{material transferred (ton/hr)} \times \left[ \frac{(\text{average wind speed (mph)})^{1.3}}{(\text{moisture content (\%)/2})^{1.4}} \right] \times (100 - \text{control}[\%]/100)$$

$$\text{Emission (tpy)} = 0.0011 \times \text{material transferred (tpy)} \times \left[ \frac{(\text{average wind speed (mph)})^{1.3}}{(\text{moisture content (\%)/2})^{1.4}} \right] \times (100 - \text{control}[\%]/100) \times (1/2000)$$

**Source:** Section 13.2.4 – Aggregate Handling and Storage Piles, AP-42, Fifth Edition, January 1995.

## INPUT DATA AND EMISSIONS CALCULATIONS

Mean Wind Speed (mph)	Actual Quantity Transferred		Material Moisture Content (pct)	Control Efficiency (pct)	Actual PM <sub>10</sub> Emission Rates	
	(ton/hr)	(ton/yr)			(lb/hr)	(tpy)
8.6	160	1,353,000	10.0	0.0	0.04	0.16

## SOURCES OF INPUT DATA

Parameter	Data Source
Mean Wind Speed	Tampa, FL, Climate of the States, Third Edition, 1985.
Actual Quantity Transferred	TEC, 1998.
Material Moisture Content	Average gypsum moisture content; TEC, 1998.
Control Efficiency	N/A

## NOTES AND OBSERVATIONS

## DATA CONTROL

<b>Data Collected by:</b>	A. Angelopulos	<b>Date:</b>	04/02/98
<b>Evaluated by:</b>	A. Trbovich	<b>Date:</b>	04/09/98
<b>Data Entered by:</b>	A. Trbovich	<b>Date:</b>	04/09/98
<b>Reviewed by:</b>	G. Nelson	<b>Date:</b>	06/12/98

# EMISSION INVENTORY WORKSHEET

Tampa Electric Company – Big Bend Station

GH-004a

## EMISSION SOURCE TYPE

**MATERIAL TRANSFER – FUGITIVE EMISSION SOURCES**

Project:

## FACILITY AND SOURCE DESCRIPTION

Emission Source Description: Gypsum Handling – Dozer Transfer from North Stackout Pile to Loadout Conveyor

Emission Control Method(s)/ID No.(s): None

Emission Point ID: GH-004a

Transfer Point ID(s):

## EMISSION ESTIMATION EQUATIONS

$$\text{Emission (lb/hr)} = 0.0011 \times \text{material transferred (ton/hr)} \times \left[ \frac{(\text{average wind speed (mph)} / 5)^{1.3}}{(\text{moisture content (\%)} / 2)^{1.4}} \right] \times (100 - \text{control}(\%)) / 100$$

$$\text{Emission (tpy)} = 0.0011 \times \text{material transferred (tpy)} \times \left[ \frac{(\text{average wind speed (mph)} / 5)^{1.3}}{(\text{moisture content (\%)} / 2)^{1.4}} \right] \times (100 - \text{control}(\%)) / 100 \times (1/2000)$$

Source: Section 13.2.4 – Aggregate Handling and Storage Piles, AP-42, Fifth Edition, January 1995.

## INPUT DATA AND EMISSIONS CALCULATIONS

Mean Wind Speed (mph)	Actual Quantity Transferred		Material Moisture Content (pct)	Control Efficiency (pct)	Actual PM <sub>10</sub> Emission Rates	
	(ton/hr)	(ton/yr)			(lb/hr)	(tpy)
8.6	160	1,353,000	10.0	0.0	0.04	0.16

## SOURCES OF INPUT DATA

Parameter	Data Source
Mean Wind Speed	Tampa, FL, Climate of the States, Third Edition, 1985.
Actual Quantity Transferred	TEC, 1998.
Material Moisture Content	Average gypsum moisture content; TEC, 1998.
Control Efficiency	N/A

## NOTES AND OBSERVATIONS

## DATA CONTROL

Data Collected by:	A. Angelopoulos	Date:	04/02/98
Evaluated by:	A. Trbovich	Date:	04/09/98
Data Entered by:	A. Trbovich	Date:	04/09/98
Reviewed by:	G. Nelson	Date:	06/12/98

# EMISSION INVENTORY WORKSHEET

Tampa Electric Company – Big Bend Station

GH-004b

## EMISSION SOURCE TYPE

**MATERIAL TRANSFER – FUGITIVE EMISSION SOURCES**

**Project:**

## FACILITY AND SOURCE DESCRIPTION

Emission Source Description: Gypsum Handling – Dozer Transfer from Loadout Conveyor to Truck

Emission Control Method(s)/ID No.(s): None

Emission Point ID: GH-004b

Transfer Point ID(s):

## EMISSION ESTIMATION EQUATIONS

$$\text{Emission (lb/hr)} = 0.0011 \times \text{material transferred (ton/hr)} \times [(\text{average wind speed (mph)}/5)^{1.3} / (\text{moisture content (\%)/2})^{1.4}] \times (100 - \text{control(\%)/100})$$

$$\text{Emission (tpy)} = 0.0011 \times \text{material transferred (tpy)} \times [(\text{average wind speed (mph)}/5)^{1.3} / (\text{moisture content (\%)/2})^{1.4}] \times (100 - \text{control(\%)/100}) \times (1/2000)$$

Source: Section 13.2.4 – Aggregate Handling and Storage Piles, AP-42, Fifth Edition, January 1995.

## INPUT DATA AND EMISSIONS CALCULATIONS

Mean Wind Speed (mph)	Actual Quantity Transferred		Material Moisture Content (pct)	Control Efficiency (pct)	Actual PM <sub>10</sub> Emission Rates	
	(ton/hr)	(ton/yr)			(lb/hr)	(tpy)
8.6	160	1,353,000	10.0	0.0	0.04	0.16

## SOURCES OF INPUT DATA

Parameter	Data Source
Mean Wind Speed	Tampa, FL, Climate of the States, Third Edition, 1985.
Actual Quantity Transferred	TEC, 1998.
Material Moisture Content	Average gypsum moisture content; TEC, 1998.
Control Efficiency	N/A

## NOTES AND OBSERVATIONS

## DATA CONTROL

Data Collected by:	A. Angelopulos	Date:	04/02/98
Evaluated by:	A. Trbovich	Date:	04/09/98
Data Entered by:	A. Trbovich	Date:	04/09/98
Reviewed by:	G. Nelson	Date:	06/12/98

# EMISSION INVENTORY WORKSHEET

Tampa Electric Company – Big Bend Station

GH-007

## EMISSION SOURCE TYPE

**MATERIAL TRANSFER – FUGITIVE EMISSION SOURCES**

Project:

## FACILITY AND SOURCE DESCRIPTION

Emission Source Description: Gypsum Handling – Conveyor GD to Conveyor GE

Emission Control Method(s)/ID No.(s): Enclosure

Emission Point ID: GH-007

Transfer Point ID(s):

## EMISSION ESTIMATION EQUATIONS

$$\text{Emission (lb/hr)} = 0.0011 \times \text{material transferred (ton/hr)} \times [(\text{average wind speed (mph)/5})^{1.3} / (\text{moisture content (\%/2)})^{1.4}] \times (100 - \text{control(\%/100)})$$

$$\text{Emission (tpy)} = 0.0011 \times \text{material transferred (tpy)} \times [(\text{average wind speed (mph)/5})^{1.3} / (\text{moisture content (\%/2)})^{1.4}] \times (100 - \text{control(\%/100)}) \times (1/2000)$$

Source: Section 13.2.4 – Aggregate Handling and Storage Piles, AP-42, Fifth Edition, January 1995.

## INPUT DATA AND EMISSIONS CALCULATIONS

Mean Wind Speed (mph)	Actual Quantity Transferred		Material Moisture Content (pct)	Control Efficiency (pct)	Actual PM <sub>10</sub> Emission Rates	
	(ton/hr)	(ton/yr)			(lb/hr)	(tpy)
8.6	160	1,353,000	10.0	90.0	<0.01	0.02

## SOURCES OF INPUT DATA

Parameter	Data Source
Mean Wind Speed	Tampa, FL, Climate of the States, Third Edition, 1985.
Actual Quantity Transferred	TEC, 1998.
Material Moisture Content	Average gypsum moisture content; TEC, 1998.
Control Efficiency	Table 3-16, Fugitive Emissions From Coal-Fired Power Plants, EPRI, June 1984.

## NOTES AND OBSERVATIONS

## DATA CONTROL

Data Collected by:	A. Angelopulos	Date:	04/02/98
Evaluated by:	A. Trbovich	Date:	04/09/98
Data Entered by:	A. Trbovich	Date:	04/09/98
Reviewed by:	G. Nelson	Date:	06/12/98



# EMISSION INVENTORY WORKSHEET

Tampa Electric Company – Big Bend Station

**GH-008**

## EMISSION SOURCE TYPE

**MATERIAL TRANSFER – FUGITIVE EMISSION SOURCES**

**Project:**

## FACILITY AND SOURCE DESCRIPTION

Emission Source Description: **Gypsum Handling – Conveyor GE to Conveyor GF**

Emission Control Method(s)/ID No.(s): **Enclosure**

Emission Point ID: **GH-008**

Transfer Point ID(s):

## EMISSION ESTIMATION EQUATIONS

$Emission (lb/hr) = 0.0011 \times material\ transferred\ (ton/hr) \times [(average\ wind\ speed\ (mph)/5)^{1.3} / (moisture\ content\ (\%/2))^{1.4}] \times (100 - control[\%]/100)$

$Emission\ (tpy) = 0.0011 \times material\ transferred\ (tpy) \times [(average\ wind\ speed\ (mph)/5)^{1.3} / (moisture\ content\ (\%/2))^{1.4}] \times (100 - control[\%]/100) \times (1/2000)$

Source: Section 13.2.4 – Aggregate Handling and Storage Piles, AP-42, Fifth Edition, January 1995.

## INPUT DATA AND EMISSIONS CALCULATIONS

Mean Wind Speed (mph)	Actual Quantity Transferred		Material Moisture Content (pct)	Control Efficiency (pct)	Actual PM <sub>10</sub> Emission Rates	
	(ton/hr)	(ton/yr)			(lb/hr)	(tpy)
8.6	160	1,353,000	10.0	90.0	<0.01	0.02

## SOURCES OF INPUT DATA

Parameter	Data Source
Mean Wind Speed	Tampa, FL, Climate of the States, Third Edition, 1985.
Actual Quantity Transferred	TEC, 1998.
Material Moisture Content	Average gypsum moisture content; TEC, 1998.
Control Efficiency	Table 3-16, Fugitive Emissions From Coal-Fired Power Plants, EPRI, June 1984.

## NOTES AND OBSERVATIONS

## DATA CONTROL

Data Collected by:	A. Angelopulos	Date:	04/02/98
Evaluated by:	A. Trbovich	Date:	04/09/98
Data Entered by:	A. Trbovich	Date:	04/09/98
Reviewed by:	G. Nelson	Date:	06/12/98

# EMISSION INVENTORY WORKSHEET

Tampa Electric Company – Big Bend Station

**GH-009**

## EMISSION SOURCE TYPE

**MATERIAL TRANSFER – FUGITIVE EMISSION SOURCES**

**Project:**

## FACILITY AND SOURCE DESCRIPTION

Emission Source Description: Gypsum Handling – Conveyor GF to Radial Stacker

Emission Control Method(s)/ID No.(s): Enclosure

Emission Point ID: GH-009

Transfer Point ID(s):

## EMISSION ESTIMATION EQUATIONS

$$\text{Emission (lb/hr)} = 0.0011 \times \text{material transferred (ton/hr)} \times [(\text{average wind speed (mph)}/5)^{1.3} / (\text{moisture content (\%)/2})^{1.4}] \times (100 - \text{control}[\%]/100)$$

$$\text{Emission (tpy)} = 0.0011 \times \text{material transferred (tpy)} \times [(\text{average wind speed (mph)}/5)^{1.3} / (\text{moisture content (\%)/2})^{1.4}] \times (100 - \text{control}[\%]/100) \times (1/2000)$$

Source: Section 13.2.4 – Aggregate Handling and Storage Piles, AP-42, Fifth Edition, January 1995.

## INPUT DATA AND EMISSIONS CALCULATIONS

Mean Wind Speed (mph)	Actual Quantity Transferred		Material Moisture Content (pct)	Control Efficiency (pct)	Actual PM <sub>10</sub> Emission Rates	
	(ton/hr)	(ton/yr)			(lb/hr)	(tpy)
8.6	160	1,353,000	10.0	90.0	<0.01	0.02

## SOURCES OF INPUT DATA

Parameter	Data Source
Mean Wind Speed	Tampa, FL, Climate of the States, Third Edition, 1985.
Actual Quantity Transferred	TEC, 1998.
Material Moisture Content	Average gypsum moisture content; TEC, 1998.
Control Efficiency	Table 3-16, Fugitive Emissions From Coal-Fired Power Plants, EPRI, June 1984.

## NOTES AND OBSERVATIONS

## DATA CONTROL

Data Collected by:	A. Angelopoulos	Date:	04/02/98
Evaluated by:	A. Trbovich	Date:	04/09/98
Data Entered by:	A. Trbovich	Date:	04/09/98
Reviewed by:	G. Nelson	Date:	06/12/98

# EMISSION INVENTORY WORKSHEET

Tampa Electric Company – Big Bend Station

**GH-010**

## EMISSION SOURCE TYPE

**MATERIAL TRANSFER – FUGITIVE EMISSION SOURCES**

**Project:**

## FACILITY AND SOURCE DESCRIPTION

Emission Source Description: **Gypsum Handling – Radial Stacker to South Stackout Pile**

Emission Control Method(s)/ID No.(s): **None**

Emission Point ID: **GH-010**

Transfer Point ID(s):

## EMISSION ESTIMATION EQUATIONS

$$\text{Emission (lb/hr)} = 0.0011 \times \text{material transferred (ton/hr)} \times [(\text{average wind speed (mph)}/5)^{1.3} / (\text{moisture content (\%)/2})^{1.4}] \times (100 - \text{control}[\%]/100)$$

$$\text{Emission (tpy)} = 0.0011 \times \text{material transferred (tpy)} \times [(\text{average wind speed (mph)}/5)^{1.3} / (\text{moisture content (\%)/2})^{1.4}] \times (100 - \text{control}[\%]/100) \times (1/2000)$$

Source: Section 13.2.4 – Aggregate Handling and Storage Piles, AP-42, Fifth Edition, January 1995.

## INPUT DATA AND EMISSIONS CALCULATIONS

Mean Wind Speed (mph)	Actual Quantity Transferred		Material Moisture Content (pct)	Control Efficiency (pct)	Actual PM <sub>10</sub> Emission Rates	
	(ton/hr)	(ton/yr)			(lb/hr)	(tpy)
8.6	160	1,353,000	10.0	0.0	0.04	0.16

## SOURCES OF INPUT DATA

Parameter	Data Source
Mean Wind Speed	Tampa, FL, Climate of the States, Third Edition, 1985.
Actual Quantity Transferred	TEC, 1998.
Material Moisture Content	Average gypsum moisture content; TEC, 1998.
Control Efficiency	N/A

## NOTES AND OBSERVATIONS

## DATA CONTROL

Data Collected by:	A. Angelopulos	Date:	04/02/98
Evaluated by:	A. Trbovich	Date:	04/09/98
Data Entered by:	A. Trbovich	Date:	04/09/98
Reviewed by:	G. Nelson	Date:	06/12/98

# EMISSION INVENTORY WORKSHEET

Tampa Electric Company – Big Bend Station

**GH-015**

## EMISSION SOURCE TYPE

**MATERIAL TRANSFER – FUGITIVE EMISSION SOURCES**

**Project:**

## FACILITY AND SOURCE DESCRIPTION

Emission Source Description: Gypsum Handling – Dozer Transfer from Long-Term Storage Pile to Trucks

Emission Control Method(s)/ID No.(s): None

Emission Point ID: GH-015

Transfer Point ID(s):

## EMISSION ESTIMATION EQUATIONS

$Emission (lb/hr) = 0.0011 \times material\ transferred\ (ton/hr) \times [(average\ wind\ speed\ (mph)/5]^{1.3} / (moisture\ content\ (\%/2))^{1.4} \times (100 - control[\%]/100)$

$Emission\ (tpy) = 0.0011 \times material\ transferred\ (tpy) \times [(average\ wind\ speed\ (mph)/5]^{1.3} / (moisture\ content\ (\%/2))^{1.4} \times (100 - control[\%]/100) \times (1/2000)$

Source: Section 13.2.4 – Aggregate Handling and Storage Piles, AP-42, Fifth Edition, January 1995.

## INPUT DATA AND EMISSIONS CALCULATIONS

Mean Wind Speed (mph)	Actual Quantity Transferred		Material Moisture Content (pct)	Control Efficiency (pct)	Actual PM <sub>10</sub> Emission Rates	
	(ton/hr)	(ton/yr)			(lb/hr)	(tpy)
8.6	160	1,353,000	10.0	0.0	0.04	0.16

## SOURCES OF INPUT DATA

Parameter	Data Source
Mean Wind Speed	Tampa, FL, Climate of the States, Third Edition, 1985.
Actual Quantity Transferred	TEC, 1998.
Material Moisture Content	Average gypsum moisture content; TEC, 1998.
Control Efficiency	N/A

## NOTES AND OBSERVATIONS

## DATA CONTROL

Data Collected by:	A. Angelopulos	Date:	04/02/98
Evaluated by:	A. Trbovich	Date:	04/09/98
Data Entered by:	A. Trbovich	Date:	04/09/98
Reviewed by:	G. Nelson	Date:	06/12/98