

One Energy Place
Pensacola, Florida 32520

Tel 850.444.6111

RECEIVED

MAY 31 2005

BUREAU OF AIR REGULATION

Certified Mail



May 27, 2005

Jonathan Holtom
Florida Department of Environmental Protection
Division of Air Resources Management
2600 Blair Stone Road
Mail Station #5510
Tallahassee, Florida 32399-2400

Dear Mr. Holtom:

RE: CRIST ELECTRIC GENERATING PLANT
ADDITIONAL INFORMATION REQUEST
SNCR CONSTRUCTION PERMIT APPLICATION
Permit No: 0330045-012-AC

Please find enclosed Gulf Power's response to your February 24, 2005 request for additional information regarding the installation of the SNCR to Unit 6 at the Crist Electric Generating Plant located in Pensacola, Florida. Included in the response is the required certification by a Professional Engineer registered in Florida.

As you may be aware, Gulf Power's schedule to begin construction of this project is critical to meeting the May 1, 2006 FDEP-Gulf Ozone Agreement and thus activity will begin in September, 2005. Please advise Gulf Power as soon as possible any potential delay to the construction schedule due to permitting processes.

We appreciate your efforts to work with us regarding the startup of this emission control system. Please call me regarding any additional questions or concerns.

Sincerely,

A handwritten signature in black ink that reads "Dwain Waters, Q.E.P." The signature is written in a cursive style.

G. Dwain Waters, Q.E.P.
Air Quality Programs Supervisor

cc: w/att: Trina Vielhauer, FDEP – Tallahassee Office
Jim Vick, Gulf Power Company
Wright, Terry, Gulf Power Company
John Dominey, Gulf Power Company
David Hollinger, Southern Company
Ms. Sandra Veazey, FDEP Northwest District Office, Pensacola, Florida
Mr. Richard Fancher, FDEP Northwest District Office, Pensacola, Florida

**CRIST UNIT 6
FDEP – SNCR REQUEST FOR ADDITIONAL INFORMATION
CERTIFICATION BY PROFESSIONAL ENGINEER**

“I, the undersigned, am a registered professional engineer in the State of Florida and hereby certify to the best of my knowledge that all information being submitted pursuant to FDEP’s request for additional information regarding the construction of a SNCR emissions control system at Crist Unit 6 is true, accurate and complete.”

Professional Engineer Signature:

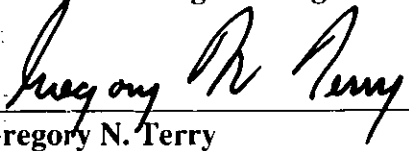

Gregory N. Terry
Registration Number: 52786

5.27.2005

Date

**GULF POWER RESPONSE TO REQUEST FOR ADDITIONAL
INFORMATION REGARDING ADDITION OF SCNR TO UNIT 6
FILE No: 0330045-012-AC
May 25, 2005**

1. **FDEP Comment:** Page 3 of the application, Purpose of Application: Only the box for Air Construction permit has been checked. However, in the comment box on the same page, Item 3 has requested that the long term use of biomass be incorporated into the Title V permit. The construction permit that temporarily authorized the burning of biomass to determine the feasibility of burning it in order to reduce NO_x emissions expired October 4, 2003. Pursuant to Rule 62-213.420(1)(a)4., F.A.C., for a Title V operation permit revision application to have been considered a timely request, it must have been submitted at least ninety days prior to expiration of the construction permit, but no later than 180 days after the emissions unit commenced operation as modified. As such, there is no currently valid authorization for burning biomass that can be incorporated into a Title V permit. If Gulf Power desires to establish the authority to burn biomass as a new fuel during the current construction permit revision, please submit a summary of the results of the testing that was performed during the test burns in 2002 and 2003. Based on the results of the tests, provide an analysis comparing past actual emissions (prior to the burning of biomass) to future actual emissions (while burning biomass), and a statement of how the burning of biomass will affect the total annual heat input over the next five years. Include a statement of request specifying which of the four biomass fuels you would like to establish the authority to burn as new fuels, and the requested amount(s) of these fuels that can be burned hourly and annually without causing unstable conditions in the boilers.

Gulf Power Response: Gulf Power hereby withdraws our request to utilize Biomass fuel at this time since there is no short term immediate plan to use the fuel. The fuel will be re-evaluated as part of the Company's strategy to meet the Clean Air Interstate Rule.

2. **FDEP Comment:** Page 10 of the application, List of Pollutants Emitted by Facility: List contains a statement of "no change from previous Title V permit". It is suspected that with the addition of biomass burning in Units 4 and 5, and with the addition of SNCR on Unit 6, the pollutants that will be emitted from these units after being modified could be different than those currently emitted. Provide a complete list of all pollutants that will be emitted as a result of the modifications.

Gulf Power Response: Gulf Power anticipates no change of pollutants as a result of installation of the SNCR on Crist Unit 6. See item 6 in regards to ammonia slip.

3. **FDEP Comment:** Page 12 of the application, Additional Requirements for All Applications: Reference is made to the Title V application that was previously submitted 6/22/04. The ability to reference previously submitted information only applies to a Title V permit revision provided that the required information has been previously submitted within the past five years. Because this is a construction permit revision that will be allowing modifications to existing operations, the information required by this section of the application must be submitted in order to detail any changes as a result of the authorized modifications.

Gulf Power Comment: See Attachment 1 for Facility Plot Plan, Process Flow Diagram and Precautions to Prevent Emissions from Unconfined Particulate Matter.

- FDEP Comment:** Page 12 of the application, Additional Requirements for Air Construction Permit Applications: Box 3, Rule Applicability Analysis was not addressed. This information needs to be provided, especially as it relates to the requested modifications.

Gulf Power Comment: The installation of SNCR on Crist Unit 6 is expected to result in lower NO_x emissions and no increase in any other emissions other than the ammonia slip noted in item 6. The operation of the unit is not expected to increase as a result of the project, and therefore no associated increase in emissions. The addition of SNCR is not a "modification" and does not therefore trigger the need for a non-PSD or PSD construction permit. Please see Attachment 2 taken from the 06/22/04 previous Title V application for the rule applicability analysis. There are no changes in the rule applicability analysis previously submitted.

- FDEP Comment:** Regarding the Cooling Tower: The information submitted states that the new cooling tower will be a like kind replacement with the exception that the drift and evaluation percent of flow will be reduced from 2.4% to 2.1%. What is different about the new cooling tower that will provide the reduced drift? Explain the difference in design drift reduction (2.4% to 2.1%) and the estimated drift reduction (2% vs. 0.005%), and what effect these changes have on actual emissions from the cooling tower.

Gulf Power Comment: The need for this item was resolved with FDEP, thus Gulf Power hereby withdraws our request for permitting the replacement of the Unit 6 Cooling Tower.

- FDEP Comment:** Regarding the SNCR: Provide a description of the location of the urea injection ports, the degree of mixing that can be expected at the injection locations, and how the controller will adjust the injection rates/number of injectors required based on load changes. How will the proposed 5ppm ammonia slip emission rate (24 hour average) be monitored? The application states that the SNCR system is designed to remove 25% of the NO_x from the exhaust stream with a guarantee of 20% reduction. Based on the design and the location of the injection ports, is 25% reduction the maximum that can ever be achieved, or could a greater reduction be achieved if needed in the future? The application also states that the SNCR system is designed for 25% removal "when operating". Does that imply that The SNCR system will be operated at will, or that it will always be operating when the proper temperature is reached in the boiler?

Gulf Power Response: The urea injectors for the Crist 6 SNCR will be located at Elevation 171'-3". There will be a total of 6 injectors spaced across the front of the boiler. The system will be installed with a single level of injectors that will operate across the unit's load range. The concentration of the injected reagent will change as the load varies. The degree of mixing will depend on boiler load and the corresponding gas

velocity profiles. The injector configuration will be designed to provide for maximum distribution and coverage over the load range and appropriate injection temperatures.

The ammonia slip average similar to Crist Unit 7 will not be continuously monitored. Currently, there is not a commercially-available instrument that provides a reliable and accurate NH₃ measurement. Wet chemistry will be utilized during the initial tuning of the system to establish an injection scheme that limits NH₃ slip to a 5 ppm 24 hour average. Additionally, Gulf Power Field Service's group will conduct initial and annual determinations utilizing FTIR (Fourier Transform Infra-Red) technology to demonstrate compliance to the 24 hour average ammonia slip.

The vendor guaranteed reduction of 20% is a conservative value based on the vendor's experience and modeling results. The vendor feels the design can accomplish 20% while complying with the 5 ppm NH₃ slip limit. A 25% reduction is the maximum design rate that is expected based on vendor modeling and experience.

The SNCR will operate as needed to meet the facility 0.20 lb/Mmbtu NO_x plant-wide emissions limit outlined in the FDEP-Gulf Ozone agreement. During these periods, the SNCR will operate whenever the Unit is operating at or above its normal low load level. If the Unit drops below this level, the SNCR system will automatically stop injection until the Unit returns to its low load level, thus the system will operate "at will" to comply to the facility limit.

Attachment 1:

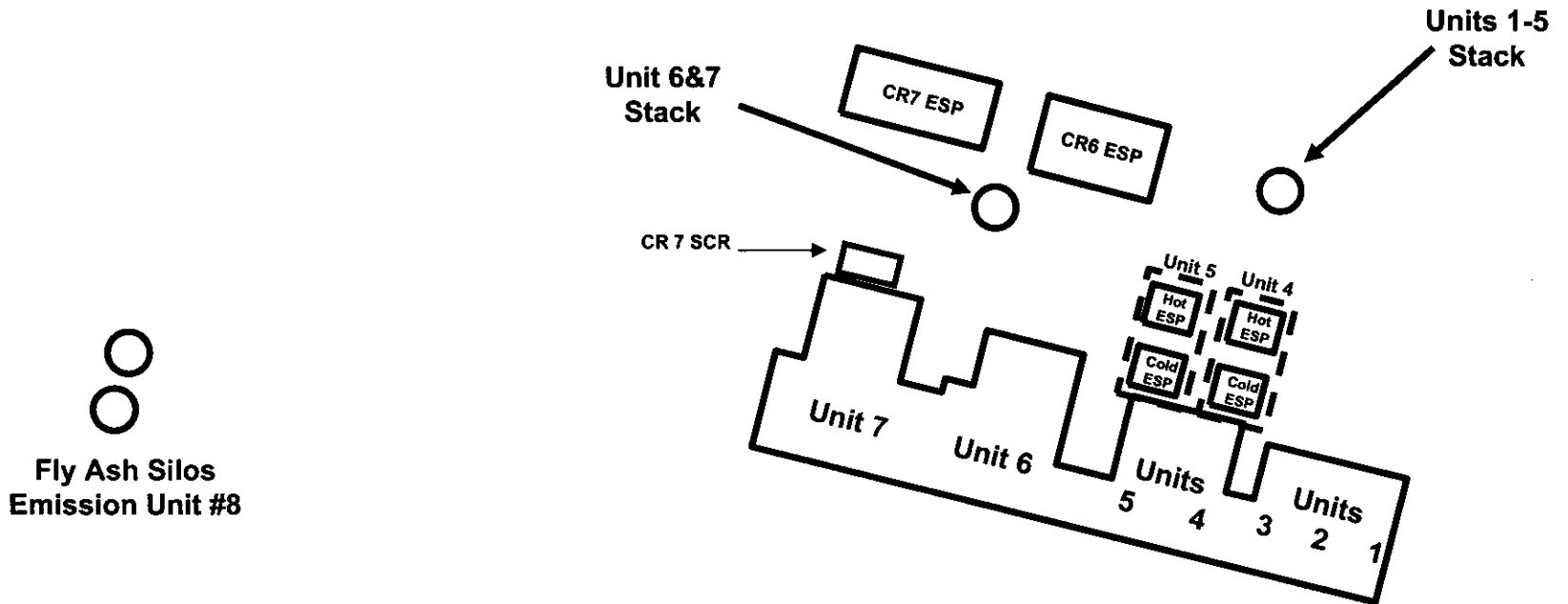

Notes:

ESP - Electrostatic Precipitators (Control Equipment)

SCR - Selective Catalytic Reduction (Control Equipment)

Not shown on this plan:

Emission Unit #9 - Material Handling of Coal and Ash and Roads (Fugitives)

Emission Unit #10 - Miscellaneous Emission Units (Tanks, Sandblasting, Cooling

Towers, Trivial, Exempt, Presumptively Exempt, and Non-regulated)

**PLANT CRIST
UNIT EMISSIONS
PLOT PLAN**

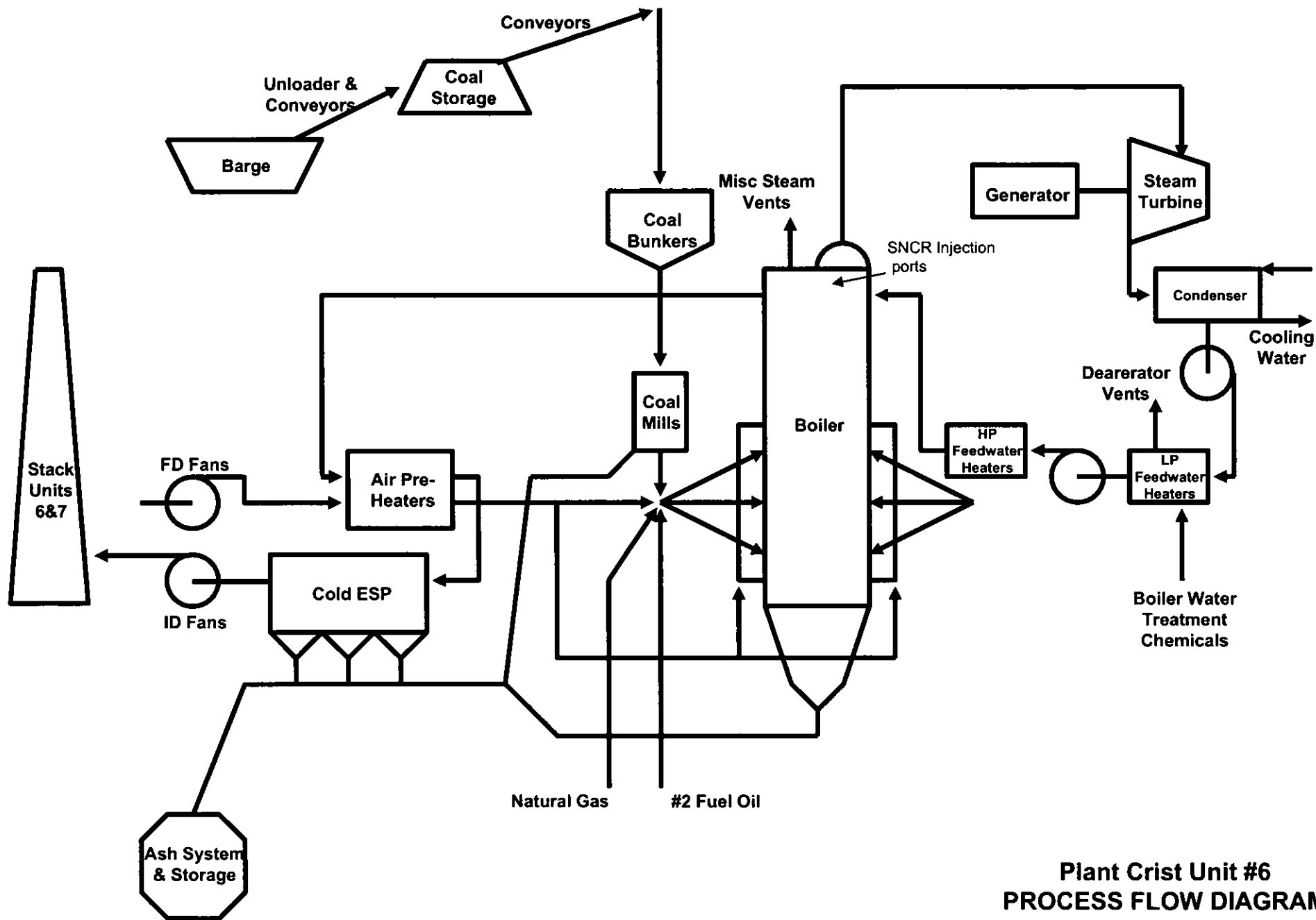

**PRECAUTIONS TO PREVENT EMISSIONS OF UNCONFINED PARTICULATE
MATTER**

1) TO PREVENT EMISSIONS OF UNCONFINED PARTICULATE MATTER WHILE UNLOADING FLY ASH, ASH LEAVING THE FACILITY WILL BE HAULED IN CLOSED CONTAINER TRUCKS. ASH BEING DISPOSED OF ON PLANT PROPERTY WILL BE MIXED WITH WATER AS IT IS BEING LOADED INTO THE TRUCKS FOR TRANSPORT TO LANDFILL.

2) THE PLANT ASH HAUL ROADS WILL BE WATERED AS NECESSARY TO CONTROL ANY UNCONFINED PARTICULATE MATTER THAT MAY BE ON THE ROADS.

3) AS SECTIONS OF THE ASH LANDFILL REACH THEIR CAPACITY THESE SECTIONS WILL BE GRASSED OVER TO PREVENT ANY PARTICULATE MATTER BEING LIFTED INTO THE WIND.

4) THE COAL PILE IS PACKED REGULARLY TO HELP IN THE PREVENTION OF COAL PILE FIRES AND LIMIT THE AMOUNT OF COAL DUST THAT MIGHT GET BLOWN OFF THE PILE IF IT WERE NOT PACKED.

5) A DUST SUPPRESSANT WILL BE APPLIED TO THE COAL ON THE CONVEYOR BELTS AS NECESSARY TO CONTROL DUST.

Attachment 2:

FDEP Rule	GULF POWER - CRIST UNIT 6 FDEP APPLICABLE REQUIREMENTS LIST FDEP Title	Facility Emission Unit Identification Number(s)	Applicable Requirement		Comments/Discussion	Unit/Facility Potential Applicability
			Yes	No/NA		
Chapter 62-4 Permits						
62-4.030	General Prohibition.	0330045	✓		State Only	Facility
62-4.04(1)	Exemptions.	0330045	✓		State Only	Facility
62-4.100	Suspension and Revocation.	0330045	✓		State Only	Facility
62-4.130	Plant Operation - Problems.	0330045	✓		State Only	Facility
Chapter 62-204 State Implementation Plan						
62-204.800	Standards of Performance for New Stationary Sources (NSPS) (see 40 CFR 60 list for subsections).					
	(7) Standards Adopted.	0330045			State only.	Unit 006
	(b) The following Standards of Performance for New Stationary Sources contained in 40 CFR 60, revised as of July 1, 1994, or later as specifically indicated.	0330045		-	State only.	Unit 006
	1. 40 CFR 60.40 Subpart D, Fossil-fuel-fired Steam Generators for which Construction is Commenced after August 17, 1971.	0330045		-	State only.	Unit 006
	2. 40 CFR 60.40a Subpart Da, Electric Utility Steam Generators for which Construction is Commenced after September 18, 1978.	0330045		-	State only.	Unit 006
	3. 40 CFR 60.40b Subpart Db, Industrial-Commercial-Institutional Steam Generating Units.	0330045		-	State only.	Unit 006
	4. 40 CFR 60.40c Subpart Dc, Small Industrial-Commercial-Institutional Steam Generating Units.	0330045		-	State only.	Unit 006
	12. 40 CFR 60.110 Subpart K, Storage Vessels for Petroleum Liquids for Which Construction, Reconstruction, or Modification Commenced after June 11, 1973, and prior to May 19, 1978.	0330045		-	State only.	Unit 006
	13. 40 CFR 60.110a Subpart Ka, Storage Vessels for Petroleum Liquids for Which Construction, Reconstruction, or Modification Commenced after May 18, 1978, and prior to July 23, 1984.	0330045		-	State only.	Unit 006
62-204.800	14. 40 CFR 60.110b Subpart Kb, Volatile Organic Liquid Storage	0330045			State only.	Unit 006

FDEP Rule	GULF POWER - CRIST UNIT 6 FDEP APPLICABLE REQUIREMENTS LIST FDEP Title	Facility Emission Unit Identification Number(s)	Applicable Requirement		Comments/Discussion	Unit/Facility Potential Applicability
			Yes	No/NA		
	Vessels (Including Petroleum Liquid Storage Vessels) for Which Construction, Reconstruction, or Modification Commenced after July 23, 1984.			-		
	29. 40 CFR 60.250 Subpart Y, Coal Preparation Plants.	0330045			State only.	Unit 006
	37. 40 CFR 60.330 Subpart GG, Stationary Gas Turbines.	0330045			State only.	Unit 006
	62. 40 CFR 60.670 Subpart OOO, Non-Metallic Mineral Processing Plants.	0330045		-	State only.	Unit 006
62-204.800(7)	(c) The Standards of Performance for New Stationary Sources adopted by reference in this section shall be controlling over other standards in this chapter except that any emissions limiting standard contained in or determined pursuant to this chapter which is more stringent than one contained in a Standard of Performance, or which regulates emissions of pollutants or emissions units not regulated by an applicable Standard of Performance, shall apply.	0330045		-	State only.	Unit 006
	(7)(d) General Provisions Adopted.	0330045			State only.	Unit 006
	(7)(e) Appendices Adopted. The following appendices of 40 CFR Part 60, revised as of July 1, 1994 or later as specifically indicated, are adopted and incorporated by reference.	0330045		-	State only.	Unit 006
	1. 40 CFR 60 Appendix A, Test Methods, are adopted by reference.	0330045			State only.	Unit 006
	2. 40 CFR 60 Appendix B, Performance Specifications.	0330045			State only.	Unit 006
	3. 40 CFR 60 Appendix C, Determination of Emission Rate Change.	0330045		-	State only.	Unit 006
	5. 40 CFR 60 Appendix F, Quality Assurance Procedures.	0330045			State only.	Unit 006
62-204.800(8)	National Emission Standards for Hazardous Air Pollutants (NESHAPS).					
	(8) Standards Adopted.	0330045			State only.	Unit 006
	(b)8. 40 CFR Part 61 Subpart M Asbestos.	0330045	✓		State only.	Unit 006
62-204.800(8)	(d) General Provisions Adopted. The general provisions of 40 CFR Part 61 Subpart A, revised July 1, 1994, are adopted and incorporated by reference except 40 CFR 61.04, 40 CFR 61.08, 40 CFR 61.11, and 40	0330045	✓		State only.	Unit 006

FDEP Rule	GULF POWER - CRIST UNIT 6 FDEP APPLICABLE REQUIREMENTS LIST FDEP Title	Facility Emission Unit Identification Number(s)	Applicable Requirement		Comments/Discussion	Unit/Facility Potential Applicability
			Yes	No/NA		
	CFR 61.18.					
62-204.800(9)	National Emission Standards for Hazardous Air Pollutants (NESHAPS) - Part 63.					
	(9) Standards Adopted.	0330045			State only.	Unit 006
	(b) 40 CFR 63 Subpart Q Chromium Emissions from Industrial Process Cooling Towers*	0330045		-	State only. *This regulation was proposed for incorporation in the FAW on March 8, 1996; not yet "effective" on state level.	Unit 006
	(a) 40 CFR 63 Subpart T Halogenated Solvent Cleaning*	0330045		-	State only. *This regulation was proposed for incorporation in the FAW on March 8, 1996; not yet "effective" on state level.	Unit 006
	(d) General Subparts Adopted.	0330045			State only.	Unit 006
	1. 40 CFR 63 Subpart A, General Provisions	0330045			State only.	Unit 006
	2. 40 CFR 63 Subpart B, Equivalent Emission Limitation by Permit (112(j))	0330045		-	State only.	Unit 006
	4. 40 CFR 63 Subpart D, Compliance Extensions for Early Reductions	0330045		-	State only.	Unit 006
62-204.800 (11)	Adoption of 40 CFR 70, Federal Title V Rule	0330045	✓		State only.	Facility
62-204.800 (12)	Adoption of 40 CFR 72, Federal Acid Rain Program	0330045	✓		State only.	Unit 006
62-204.800 (13)	Adoption of 40 CFR 73, SO2 Allowance System	0330045	✓		State only.	Unit 006
62-204.800 (14)	Adoption of 40 CFR 75, CEMS	0330045	✓		State only.	Unit 006
62-204.800 (15)	Adoption of 40 CFR 76, Acid Rain Nox Requirement	0330045	✓		State only.	Unit 006
62-204.800 (16)	Adoption of 40 CFR 77, Acid Rain Excess Emissions	0330045	✓		State only.	Unit 006
62-204.800 (19)	Adoption of 40 CFR 82, Stratospheric Ozone	0330045	✓		State only.	Unit 006/ Facility

FDEP Rule	GULF POWER - CRIST UNIT 6 FDEP APPLICABLE REQUIREMENTS LIST FDEP Title	Facility Emission Unit Identification Number(s)	Applicable Requirement		Comments/Discussion	Unit/Facility Potential Applicability
			Yes	No/NA		
Chapter 62-210 Stationary Sources - General Requirements						
62-210.300	Permits Required.					
	(2) Air Operation Permits. Except (b)	0330045	✓			Facility
	(3)(a) Exemptions - #1-29.	0330045	✓			Facility
	(3)(b) Temporary Exemptions.	0330045	✓			Facility
62-210.300	(5) Notification of Startup. The owners or operator of any emissions unit or facility which has a valid air operation permit which has been shut down more than one year, shall notify the Department in writing of the intent to start up such emissions unit or facility, a minimum of 60 days prior to the intended startup date.	0330045	✓		May apply in the future.	Facility
	(a) The notification shall include information as to the startup date, anticipated emission rates or pollutants released, changes to processes or control devices which will result in changes to emission rates, and any other conditions which may differ from the valid outstanding operation permit.	0330045	✓		May apply in the future.	Facility
	(b) If, due to an emergency, a startup date is not known 60 days prior thereto, the owner shall notify the Department as soon as possible after the date of such startup is ascertained.	0330045	✓		May apply in the future.	Facility
62-210.370	Reports.					
	(1) Notification of Intent to Relocate Air Pollutant Emitting Facility.	0330045				Unit 006
	(3) Annual Operating Report for Air Pollutant Emitting Facility.	0330045	✓			Facility
62-210.650	Circumvention.	0330045				Unit 006
62-210.700	Excess Emissions.	0330045	✓			Unit 006
62-210.900	Forms and Instructions.	0330045	✓			Facility
	(5) Annual Operating Reports	0330045	✓			Facility
Chapter 62-213 Operation Permits for Major Sources of Air Pollution						
62-213.205	Annual Emissions Fee.	0330045	✓			Facility

FDEP Rule	GULF POWER - CRIST UNIT 6 FDEP APPLICABLE REQUIREMENTS LIST FDEP Title	Facility Emission Unit Identification Number(s)	Applicable Requirement		Comments/Discussion	Unit/Facility Potential Applicability
			Yes	No/NA		
62-213.400	Permits and Permit Revisions Required.	0330045	✓			Facility
62-213.410	Changes Without Permit Revision.	0330045	✓			Facility
62-213.415	Trading of Emissions Within a Source.	0330045	✓		May apply in the future.	Unit 006 /Facility
62-213.460	Permit Shield.	0330045	✓			Facility
Chapter 62-214 Requirements for Sources Subject to the Federal Acid Rain Program						
62-214.300	Applicability.	0330045	✓			Unit 006
62-214.340	Exemptions.					
	(5) The owners and operators of each unit . . .	0330045	✓			Unit 006
	(6) A new unit shall no longer be exempted . . .	0330045				Unit 006
	(7) A retired unit shall no longer be exempted . . .	0330045	✓			Unit 006
62-214.350	Certification.	0330045	✓			Unit 006
62-214.430	Implementation and Termination of Compliance Options. Procedures for activation and termination of compliance options.					
	(1) Activation.	0330045	✓			Unit 006
	(2) Termination.	0330045	✓			Unit 006
Chapter 62-252 Gasoline Vapor Control						
62-252.300	Gasoline Dispensing Facilities - Stage I Vapor Recovery.					
	(2) Prohibition.	0330045				Facility
	(3) Control Technology Requirements.	0330045				Facility
	(4) Compliance Schedule.	0330045			State Only	Facility
62-252.400	Gasoline Dispensing Facilities - Stage II Vapor Recovery.					
	(2) Prohibition.	0330045			State Only	Facility

FDEP Rule	GULF POWER - CRIST UNIT 6 FDEP APPLICABLE REQUIREMENTS LIST FDEP Title	Facility Emission Unit Identification Number(s)	Applicable Requirement		Comments/Discussion	Unit/Facility Potential Applicability
			Yes	No/NA		
	(3) Control Technology Requirements.	0330045			State Only	Facility
	(4) Compliance Schedules.	0330045			State Only	Facility
	(5) Testing.	0330045			State Only	Facility
	(6) Recordkeeping.	0330045			State Only	Facility
	(7) System Maintenance.	0330045			State Only	Facility
62-252.400	(8) Training.	0330045			State Only	Facility
62-252.500	Gasoline Tanker Trucks.					
	(2) Prohibitions.	0330045			State Only	Facility
	(3) Leak Testing.	0330045			State Only	Facility
Chapter 62-256 Open Burning and Frost Protection Fires						
62-256.300	Prohibitions.	0330045	✓		State Only	Facility
62-256.450	Burning for Cold or Frost Protection.	0330045			State Only	Facility
62-256.500	Land Clearing.	0330045	✓		State Only	Facility
62-256.600	Industrial, Commercial, Municipal, and Research Open Burning.	0330045	✓		State Only	Facility
62-256.700	Open Burning Allowed.	0330045	✓		State Only	Facility
Chapter 62-257 Asbestos Removal						
62-257.301	Notification Procedure and Fee.	0330045	✓		State Only	Facility
62-257.400	Fee Schedule.	0330045	✓		State Only	Facility
62-257.900	Form.	0330045	✓		State Only	Facility
Chapter 62-281 Motor Vehicle Air Conditioning Refrigerant Recovery and Recycling.						
62-281.300	Applicability.	0330045			State Only	Facility
62-281.400	Compliance Requirements.	0330045			State Only	Facility

FDEP Rule	GULF POWER - CRIST UNIT 6 FDEP APPLICABLE REQUIREMENTS LIST FDEP Title	Facility Emission Unit Identification Number(s)	Applicable Requirement		Comments/Discussion	Unit/Facility Potential Applicability
			Yes	No/NA		
62-281.500	Establishment Certification.					
62-281.500	(1) Initial Certification.	0330045			State Only	Facility
	(2) Renewal Certification.	0330045			State Only	Facility
	(3) Fees.	0330045			State Only	Facility
	(4) Certificate of Compliance.	0330045			State Only	Facility
62-281.600	Training Requirements.					
62-281.700	Equipment Certification.					
62-281.900	Forms.					
Chapter 62-296 Stationary Sources -- Emission Standards						
62-296.320	General Pollutant Emission Limiting Standards.					
	(1) Volatile organic compounds emissions or organic solvents emissions.	0330045		-		Facility
	(2) Objectionable Odor Prohibited.	0330045	✓			Facility
	(3) Open Burning.	0330045	✓		State Only	Facility
	(4)(a) Process Weight Table.	0330045				Unit 006
	(4)(b) General Visible Emissions Standard.	0330045	✓			Facility
	(4)(c) Unconfined Emissions of Particulate Matter.	0330045	✓			Facility
62-296.405	Fossil Fuel Steam Generators with More than 250 Million Btu per Hour Heat Input.					
	(1) Existing Emissions Units.					
	(a) Visible emissions.	0330045	✓			Unit 006
	(b) Particulate Matter - 0.1 pound per million Btu heat input, as measured by applicable compliance methods.	0330045	✓			Unit 006
	(c) Sulfur Dioxide, as measured by applicable compliance methods.	0330045	✓			Unit 006

FDEP Rule	GULF POWER - CRIST UNIT 6 FDEP APPLICABLE REQUIREMENTS LIST FDEP Title	Facility Emission Unit Identification Number(s)	Applicable Requirement		Comments/Discussion	Unit/Facility Potential Applicability
			Yes	No/NA		
	1. (c) e. Sources burning liquid fuel.	0330045	✓		1.98 lbs/MBTU	Unit 006
	2. (c) Sources burning solid fuel.	0330045	✓		5.90 lbs/MBTU	Unit 006
	3. Owners of fossil fuel steam generators shall monitor their emissions and the effects of the emissions on ambient concentrations of sulfur dioxide, in a manner, frequency, and locations approved, and deemed reasonably necessary and ordered by the Department.	0330045	✓		Not currently listed in permit. No notice deemed necessary to plant.	Unit 006
	(d) Nitrogen Oxides (expressed as NO _x).	0330045				Unit 006
62-296.405	(e) Test Methods and Procedures.	0330045	✓		Presumably federally enforceable.	Unit 006
	(f) Continuous Emissions Monitoring Requirements.	0330045	✓			Unit 006
	(g) Quarterly Reporting Requirements.	0330045	✓			Unit 006
	(2) New Emissions Units.					
	(a) Visible Emissions - See Rule 62-204.800(7) and 40 CFR 60.42 and 60.42a	0330045		-		Unit 006
	(b) Particulate Matter - See Rule 62-204.800(7) and 40 CFR 60.42 and 60.42a	0330045		-		Unit 006
	(c) Sulfur Dioxide - See Rule 62-204.800(7) and 40 CFR 60.43 and 60.43a	0330045		-		Unit 006
	(d) Nitrogen Oxides - See Rule 62-204.800(7) and 40 CFR 60.44 and 60.44a	0330045		-		Unit 006
62-296.406	Fossil Fuel Steam Generators with Less than 250 Million Btu per Hour Heat Input, New and Existing Emissions Units.					
	(1) Visible Emissions	0330045				Unit 006
	(2) Particulate Matter - Best available control technology in accordance with Rule 62-210.200(40)	0330045		-		Unit 006
	(3) Sulfur Dioxide - Best available control technology in accordance with Rule 62-210.200(40)	0330045		-		Unit 006

FDEP Rule	GULF POWER - CRIST UNIT 6 FDEP APPLICABLE REQUIREMENTS LIST FDEP Title	Facility Emission Unit Identification Number(s)	Applicable Requirement		Comments/Discussion	Unit/Facility Potential Applicability
			Yes	No/NA		
62-296.411	Sulfur Storage and Handling Facilities	0330045				Unit 006
62-296.500	Reasonably Available Control Technology (RACT) - Volatile Organic Compounds (VOC) and Nitrogen Oxides (NO _x) Emitting Facilities.					
	(1) Applicability.	0330045				Unit 006
	(2) Permit, Recordkeeping, and Compliance Reporting Requirements.	0330045				Unit 006
	(a) Permits - Special Considerations.	0330045				Unit 006
	(b) Recordkeeping.	0330045				Unit 006
62-296.500	(c) Reporting.	0330045				Unit 006
	(3) Exceptions.	0330045				Unit 006
	(4) Consideration of Exempt Solvents	0330045				Unit 006
	(5) Compliance may be demonstrated for surface coating and graphic arts facilities on a 24-hour weighted average basis for a single source point with a single emission limit.	0330045				Unit 006
62-296.508	Petroleum Liquid Storage					
	(1) Applicability.	0330045				Unit 006
	(2) Control Technology.	0330045				Unit 006
	(3) Test Methods and Procedures.	0330045				Unit 006
62-296.511	Solvent Metal Cleaning.					
	(1) Applicability.	0330045				Unit 006
	(2) Cold Cleaning Control Technology.	0330045				Unit 006
	(3) Open Top Vapor Degreaser Control Technology.	0330045				Unit 006
	(4) Conveyorized Degreaser Control Technology.	0330045				Unit 006
	(5) Test Methods and Procedures.	0330045			* 8-hr test requirement not in SIP.	Unit 006

FDEP Rule	GULF POWER - CRIST UNIT 6 FDEP APPLICABLE REQUIREMENTS LIST FDEP Title	Facility Emission Unit Identification Number(s)	Applicable Requirement		Comments/Discussion	Unit/Facility Potential Applicability
			Yes	No/NA		
62-296.516	Petroleum Liquid Storage Tanks with External Floating Roofs					
	(1) Applicability.	0330045				Unit 006
	(2) Control Technology.	0330045				Unit 006
	(3) Test Methods and Procedures.	0330045				Unit 006
62-296.570	Reasonably Available Control Technology (RACT) - Requirements for Major VOC- 0330045 and NO _x - Emitting Facilities.					
	(1) Applicability.	0330045			State Only	Unit 006
	(2) Compliance Requirements.	0330045			State Only	Unit 006
62-296.570	(3) Operation Permit Requirements.	0330045			State Only	Unit 006
	(4) RACT Emission Limiting Standards.	0330045			State Only	Unit 006
	(a) Compliance Dates and Monitoring.	0330045			State Only	Unit 006
	(b) Emission Limiting Standards.	0330045			State Only	Unit 006
	(c) Exception for Startup, Shutdown or Malfunction.	0330045			State Only	Unit 006
62-296.700	Reasonably Available Control Technology (RACT) Particulate Matter.					
	(1) Applicability.	0330045				Unit 006
	(2) Exemptions.	0330045				Unit 006
	(3) Specific RACT Emission Limiting Standards for Stationary Emissions Units.	0330045				Unit 006
	(4) Maximum Allowable Emission Rates.	0330045				Unit 006
	(a) Emissions Unit Data.	0330045				Unit 006
	(b) Maximum Emission Rates.	0330045				Unit 006
	(5) Circumvention.	0330045				Unit 006
	(6) Operation and Maintenance Plan.	0330045				Unit 006

FDEP Rule	GULF POWER - CRIST UNIT 6 FDEP APPLICABLE REQUIREMENTS LIST FDEP Title	Facility Emission Unit Identification Number(s)	Applicable Requirement		Comments/Discussion	Unit/Facility Potential Applicability
			Yes	No/NA		
	(a) Air Pollution Control Devices and Collection Systems.	0330045				Unit 006
	(b) Control Equipment Data.	0330045				Unit 006
	(c) Processing or Materials Handling Systems.	0330045				Unit 006
	(d) Fossil Fuel Steam Generators.	0330045				Unit 006
62-296.702	Fossil Fuel Steam Generators.					
	(1) Applicability.	0330045				Unit 006
	(2) Emission Limitations.	0330045				Unit 006
	(a) Particulate Matter - 0.10 lb/mmBtu	0330045				Unit 006
62-296.711	(b) Visible Emissions - 20% opacity.	0330045				Unit 006
	(3) Test Methods and Procedures.	0330045				Unit 006
	Materials Handling, Sizing, Screening, Crushing and Grinding Operations.					
	(1) Applicability	0330045				Unit 006
	(2) Emission Limitations.	0330045				Unit 006
	(3) Test Methods and Procedures.	0330045				Unit 006
Chapter 62-297 Stationary Sources -- Emission Monitoring						
62-297.310	General Test Requirements.	0330045	✓			Unit 006
	(1) Required Number of Test Runs	0330045	✓			Unit 006
	(2) Operating Rate During Testing	0330045	✓			Unit 006
	(3) Calculation of Emission Rate	0330045	✓			Unit 006
	(4) Applicable Test Procedures.	0330045	✓			Unit 006
	(a) Required Sampling Time.	0330045	✓			Unit 006
	1. Unless otherwise specified in the applicable rule, the required	0330045	✓			Unit 006

FDEP Rule	GULF POWER - CRIST UNIT 6 FDEP APPLICABLE REQUIREMENTS LIST FDEP Title	Facility Emission Unit Identification Number(s)	Applicable Requirement		Comments/Discussion	Unit/Facility Potential Applicability
			Yes	No/NA		
	sampling time for each test run shall be no less than one hour and no greater than four hours, and the sampling time at each sampling point shall be of equal intervals of at least two minutes.					
	2. Opacity Compliance Tests.	0330045	✓			Unit 006
	(b) Minimum Sample Volume.	0330045	✓			Unit 006
	(c) Required Flow Rate Range.	0330045	✓			Unit 006
	(d) Calibration.	0330045	✓			Unit 006
	(e) EPA Method 5.	0330045	✓			Unit 006
	(5) Determination of Process Variables.	0330045	✓			Unit 006
	(6) Required Stack Sampling Facilities					
	(a) Permanent Test Facilities.	0330045	✓			Unit 006
	(b) Temporary Test Facilities.	0330045				Unit 006
	(c) Test Facilities.	0330045	✓			Unit 006
62-297.310	1. Sampling Ports.	0330045	✓			Unit 006
	(d) Work Platforms.	0330045	✓			Unit 006
	(e) Access.	0330045	✓			Unit 006
	(f) Electrical Power.	0330045	✓			Unit 006
	(g) Sampling Equipment Support.	0330045	✓			Unit 006
	(7) Frequency of Compliance Tests.					
	(a) General Compliance Testing.	0330045	✓			Unit 006
	1. Compliance test requirement prior to obtaining operating permit.	0330045				Unit 006
	2. Annual test requirement for excess PM emissions.	0330045	✓			Unit 006
	3. Annual test requirement prior to obtaining renewal permit.	0330045	✓			Unit 006

FDEP Rule	GULF POWER - CRIST UNIT 6 FDEP APPLICABLE REQUIREMENTS LIST FDEP Title,	Facility Emission Unit Identification Number(s)	Applicable Requirement		Comments/Discussion	Unit/Facility Potential Applicability
			Yes	No/NA		
	4.(a) Annual VE test,	0330045	✓			Unit 006
	(b) Annual test for lead, acrylonitrile and other regulated pollutants,	0330045				Unit 006
	(c) Annual test for each NESHAP pollutant	0330045				Unit 006
	5. No annual PM test required if burn no liquid and/or solid fuel for greater than 400 hrs/year.	0330045		-		Unit 006
	6. Exemption from semi-annual PM test for steam generators.	0330045				Unit 006
	7. Exemption from quarterly PM test for units not utilizing liquid and/or solid fuel for more than 100 hrs.	0330045		-		Unit 006
	8. Five year VE test requirement for units that operate no more than 400 hrs/year.	0330045		-		Unit 006
	9. Fifteen day advance notification requirement prior to test.	0330045	✓			Unit 006
	10. Compliance test exemption for exempt units and units utilizing a general permit.	0330045		-		Unit 006
62-297.310	(b) Special Compliance Tests.	0330045	✓		Applicable upon any complaint.	Unit 006
	(c) Waiver of Compliance Test Requirement.	0330045	✓		SO2 24 hour CEM/ FS&A program in lieu of annual compliance test.	Unit 006
	(8) Test Reports.	0330045	✓			Unit 006

EPA Rule	GULF POWER - CRIST UNIT 6 EPA APPLICABLE REQUIREMENTS LIST EPA Title	(AIRS) Facility Emission Unit Identification Number(s)	Applicable Requirement		Comments/Discussion	Unit/Facility Potential Applicability
			Yes	No/NA		
Part 60 - EPA Regulations on Standards of Performance for New Stationary Sources						
Subpart A — General Provisions						
60.7	Notification and record keeping.	0330045				Unit 006
60.8	Performance tests.	0330045				Unit 006
60.11	Compliance with standards and maintenance requirements.	0330045				Unit 006
60.12	Circumvention.	0330045				Unit 006
60.13	Monitoring requirements	0330045				Unit 006
60.19	General notifications and reporting requirements	0330045				Unit 006
Subpart D — Standards of Performance for Fossil-Fuel Fired Steam Generators for Which Construction is Commenced After August 17, 1971						
60.42	Standard for particulate matter.	0330045				Unit 006
60.43	Standard for sulfur dioxide.	0330045				Unit 006
60.44	Standard for nitrogen oxides.	0330045				Unit 006
60.45	Emission and fuel monitoring.	0330045				Unit 006
60.46	Test methods and procedures.	0330045				Unit 006
Subpart Da — Standards of Performance for Electric Utility Steam Generating Units for Which Construction is Commenced After September 18, 1978						
60.42a	Standard for particulate matter.	0330045				Unit 006
60.43a	Standard for sulfur dioxide.	0330045				Unit 006
60.44a	Standard for nitrogen oxides.	0330045				Unit 006
60.45a	Commercial demonstration permit.	0330045		X		Unit 006
60.46a	Compliance provisions.	0330045				Unit 006

EPA Rule	GULF POWER - CRIST UNIT 6 EPA APPLICABLE REQUIREMENTS LIST EPA Title	(AIRS) Facility Emission Unit Identification Number(s)	Applicable Requirement		Comments/Discussion	Unit/Facility Potential Applicability
			Yes	No/NA		
60.47a	Emission monitoring.	0330045				Unit 006
60.48a	Compliance determination procedures and methods.	0330045				Unit 006
60.49a	Reporting requirements.	0330045				Unit 006
Subpart Db — Standards of Performance for Industrial-Commercial-Institutional Steam Generating Units						
60.42b	Standard for sulfur dioxide.	0330045				Unit 006
60.43b	Standard for particulate matter.	0330045				Unit 006
60.44b	Standard for nitrogen oxides.	0330045				Unit 006
60.45b	Compliance and performance test methods and procedures for sulfur dioxide.	0330045		-		Unit 006
60.46b	Compliance and performance test methods and procedures for particulate matter and nitrogen oxides.	0330045		-		Unit 006
60.47b	Emission monitoring for sulfur dioxide.	0330045				Unit 006
60.48b	Emission monitoring for particulate matter and nitrogen oxides.	0330045				Unit 006
60.49b	Reporting and recordkeeping.	0330045				Unit 006
Subpart Dc — Standards of Performance for Small Industrial-Commercial-Institutional Steam Generating Units						
60.42c	Standard for sulfur dioxide.	0330045				Unit 006
60.43c	Standard for particulate matter.	0330045				Unit 006
60.44c	Compliance and performance test methods and procedures for sulfur dioxide.	0330045		-		Unit 006
60.45c	Compliance and performance test methods and procedures for particulate matter.	0330045		-		Unit 006
60.46c	Emission monitoring for sulfur dioxide.	0330045				Unit 006
60.47c	Emission monitoring for particulate matter.	0330045				Unit 006

EPA Rule	GULF POWER - CRIST UNIT 6 EPA APPLICABLE REQUIREMENTS LIST EPA Title	(AIRS) Facility Emission Unit Identification Number(s)	Applicable Requirement		Comments/Discussion	Unit/Facility Potential Applicability
			Yes	No/NA		
60.48c	Reporting and recordkeeping.	0330045				Unit 006
Subpart K — Standards of Performance for Storage Vessels for Petroleum Liquids for Which Construction, Reconstruction, or Modification Commenced After June 11, 1973, and Prior to May 19, 1978						
60.112	Standard for volatile organic compounds (VOC).	0330045				Unit 006
60.113	Monitoring of operations.	0330045				Unit 006
Subpart Ka — Standards of Performance for Storage Vessels for Petroleum Liquids for Which Construction, Reconstruction, or Modification Commenced After May 18, 1978, and Prior to July 23, 1984						
60.112a	Standard for volatile organic compounds (VOC).	0330045				Unit 006
60.113a	Testing and procedures.	0330045				Unit 006
60.114a	Alternative means of emission limitations.	0330045				Unit 006
60.115a	Monitoring of operations.	0330045				Unit 006
Subpart Kb — Standards of Performance for Volatile Organic Liquid Storage Vessels (Including Petroleum Liquid Storage Vessels) for Which Construction, Reconstruction, or Modification Commenced After July 23, 1984						
60.112b	Standard for volatile organic compounds (VOC).	0330045				Unit 006
60.113b	Testing and procedures.	0330045				Unit 006
60.114b	Alternative means of emission limitations.	0330045				Unit 006
60.115b	Recordkeeping and reporting requirements.	0330045				Unit 006
60.116b	Monitoring of operations.	0330045				Unit 006
Subpart Y — Standards of Performance for Coal Preparation Plants						
60.252	Standard for particulate matter.	0330045				Unit 006
60.253	Monitoring of operations.	0330045				Unit 006

EPA Rule	GULF POWER - CRIST UNIT 6 EPA APPLICABLE REQUIREMENTS LIST EPA Title	(AIRS) Facility Emission Unit Identification Number(s)	Applicable Requirement		Comments/Discussion	Unit/Facility Potential Applicability
			Yes	No/NA		
60.254	Test methods and procedures.	0330045				Unit 006
Subpart GG — Standards of Performance for Stationary Gas Turbines						
60.332	Standard for nitrogen oxides.	0330045				Unit 006
60.333	Standard for sulfur dioxide.	0330045				Unit 006
60.334	Monitoring of operations.	0330045				Unit 006
60.335	Test methods and procedures.	0330045				Unit 006
Subpart OOO — Standards of Performance for Nonmetallic Mineral Processing Plants						
60.672	Standard for Particulate Matter.	0330045				Unit 006
60.674	Monitoring of Operations.	0330045				Unit 006
60.676	Reporting and Recordkeeping.	0330045				Unit 006
Part 61 - EPA Regulations on National Emission Standards for Hazardous Air Pollutants						
Subpart A — General Provisions						
61.05	Prohibited Activities.	0330045	✓			Facility
61.09	Notification of Startup.	0330045				Facility
61.10	Source Reporting and Request for Waiver of Compliance.	0330045				Facility
61.11	Waiver of Compliance.	0330045				Facility
61.12(b)	Compliance with Standards and Maintenance Requirements.	0330045	✓			Facility
61.13	Emission Tests and Waiver of Emission Tests.	0330045				Facility
61.14	Monitoring Requirements.	0330045				Facility
61.19	Circumvention.	0330045				Facility
Subpart M — National Emission Standards for Asbestos		0330045	✓			Facility

EPA Rule	GULF POWER - CRIST UNIT 6 EPA APPLICABLE REQUIREMENTS LIST EPA Title	(AIRS) Facility Emission Unit Identification Number(s)	Applicable Requirement		Comments/Discussion	Unit/Facility Potential Applicability
			Yes	No/NA		
Appendix C to Part 61 — Quality Assurance Procedures		0330045	✓			Facility
Part 63 - EPA Regulations on National Emission Standards for Hazardous Air Pollutants for Source Categories						
Subpart A — General Provisions						
63.4	Prohibited Activities and Circumvention.	0330045		X		Unit 006
63.6	Compliance with Standards and Maintenance Requirements.	0330045				Unit 006
63.7	Performance Testing Requirements.	0330045				Unit 006
63.8	Monitoring Requirements.	0330045				Unit 006
63.9	Notification Requirements.	0330045				Unit 006
63.10	Reporting and Recordkeeping Requirements.	0330045				Unit 006
63.11	Control Device Requirements.	0330045				Unit 006
Subpart Q — National Emission Standards for Industrial Process Cooling Towers						
63.402	Standard.	0330045				Unit 006
63.403	Compliance Dates.	0330045				Unit 006
63.404	Compliance Demonstrations.	0330045				Unit 006
63.405	Notification Requirements.	0330045				Unit 006
63.406	Recordkeeping and Reporting Requirements.	0330045				Unit 006
Subpart T — National Emission Standards for Halogenated Solvent Cleaning						
63.462	Batch Cold Cleaning Machine Standards.	0330045				Unit 006
63.463	Batch Vapor and In-Line Cleaning Machine Standards.	0330045				Unit 006
63.464	Alternative Standards.	0330045				Unit 006
63.465	Test Methods.	0330045				Unit 006

EPA Rule	GULF POWER - CRIST UNIT 6 EPA APPLICABLE REQUIREMENTS LIST EPA Title	(AIRS) Facility Emission Unit Identification Number(s)	Applicable Requirement		Comments/Discussion	Unit/Facility Potential Applicability
			Yes	No/NA		
63.466	Monitoring Procedures.	0330045				Unit 006
63.467	Recordkeeping Requirements.	0330045				Unit 006
63.468	Reporting Requirements.	0330045				Unit 006
Part 72 - EPA Acid Rain Program Permits						
Subpart A — General Provisions						
72.7	New Units Exemption.	0330045				Unit 006
72.8	Retired Units Exemption.	0330045				Unit 006
72.9	Standard Requirements.	0330045	✓			Unit 006
Subpart B — Designated Representative						
72.20	Authorization and Responsibilities of the Designated Representative	0330045	✓			Unit 006
72.21	Submissions.	0330045	✓			Unit 006
72.22	Alternate Designated Representative.	0330045	✓			Unit 006
72.23	Changing the Designated Representative, Alternate Designated Representative; Changes in the Owners and Operators.	0330045	✓			Unit 006
Subpart C — Acid Rain Applications						
72.30	Requirements to Apply.	0330045	✓			Unit 006
72.32	Permit Applications Shield and Binding Effect of Permit Application.	0330045	✓			Unit 006
72.33	Identification of Dispatch System.	0330045	✓			Unit 006
Subpart D — Acid Rain Compliance Plan and Compliance Options						
72.40	General.	0330045	✓			Unit 006
72.41	Phase I Substitution Plans.	0330045				Unit 006

EPA Rule	GULF POWER - CRIST UNIT 6 EPA APPLICABLE REQUIREMENTS LIST EPA Title	(AIRS) Facility Emission Unit Identification Number(s)	Applicable Requirement		Comments/Discussion	Unit/Facility Potential Applicability
			Yes	No/NA		
72.42	Phase I Extension Plans.	0330045	✓		Crist Unit 6 & 7	Unit 006
72.43	Phase I Reduced Utilization Plans.	0330045	✓			Unit 006
72.44	Phase II Repowering Extensions.	0330045				Unit 006
Subpart E — Acid Rain Permit Contents						
72.51	Permit Shield.	0330045	✓			Unit 006
Subpart I - Compliance Certification						
72.90	Annual Compliance Certification Report.	0330045	✓			Unit 006
72.91	Phase I Unit Adjusted Utilization.	0330045	✓			Unit 006
72.92	Phase I Unit Allowance Surrender.	0330045	✓			Unit 006
72.93	Units with Phase I Extension Plans.	0330045				Unit 006
72.94	Units with Repowering Extension Plans.	0330045				Unit 006
Part 73 - EPA Acid Rain Program Sulfur Dioxide Allowance System						
Subpart C — Allowance Tracking System						
73.33	Authorized Account Representative	0330045	✓			Unit 006
73.35	Compliance.	0330045	✓			Unit 006
Part 75 - EPA Acid Rain Program For Continuous Emission Monitoring						
Subpart A — General						
75.4	Compliance Dates.	0330045	✓			Unit 006
75.5	Prohibitions.	0330045	✓			Unit 006
Subpart B — Monitoring Provisions						
75.10	General Operating Requirements.	0330045	✓			Unit 006

EPA Rule	GULF POWER - CRIST UNIT 6 EPA APPLICABLE REQUIREMENTS LIST EPA Title	(AIRS) Facility Emission Unit Identification Number(s)	Applicable Requirement		Comments/Discussion	Unit/Facility Potential Applicability
			Yes	No/NA		
75.11	Specific Provisions for Monitoring SO ₂ Emissions (SO ₂ and Flow Monitors).	0330045	✓			Unit 006
75.12	Specific Provisions for Monitoring NO _x Emissions (NO _x and Diluent Gas Monitors).	0330045	✓			Unit 006
75.13	Specific Provisions for Monitoring CO ₂ Emissions.	0330045	✓			Unit 006
75.14	Specific Provisions for Monitoring Opacity.	0330045	✓			Unit 006
75.15	Specific Provisions for Monitoring SO ₂ Emissions Removal by Qualifying Phase I Technology.	0330045		-		Unit 006
75.16	Specific Provisions for Monitoring Emissions from Common, By-Pass, and Multiple Stacks for SO ₂ Emissions and Heat Input Determinations.	0330045		-		Unit 006
75.17	Specific Provisions for Monitoring Emissions from Common, By-Pass, and Multiple Stacks for NO _x Emission Rate.	0330045		-		Unit 006
75.18	Specific Provisions for Monitoring Emissions from Common, By-Pass, and Multiple Stacks for Opacity.	0330045		-		Unit 006
Subpart C — Operation and Maintenance Requirements						
75.20	Certification and Recertification Procedures.	0330045	✓			Unit 006
75.21	Quality Assurance and Quality Control Requirements.	0330045	✓			Unit 006
75.22	Reference Test Methods.	0330045	✓			Unit 006
75.24	Out-of-Control Periods.	0330045	✓			Unit 006
Subpart D — Missing Data Substitution Procedures						
75.30	General Provisions.	0330045	✓			Unit 006
75.31	Initial Missing Data Procedures.	0330045	✓			Unit 006
75.32	Determination of Monitor Data Availability for Standard Missing Data Procedures.	0330045	✓			Unit 006
75.33	Standard Missing Data Procedures.	0330045	✓			Unit 006

EPA Rule	GULF POWER - CRIST UNIT 6 EPA APPLICABLE REQUIREMENTS LIST EPA Title	(AIRS) Facility Emission Unit Identification Number(s)	Applicable Requirement		Comments/Discussion	Unit/Facility Potential Applicability
			Yes	No/NA		
75.34	Units with Add-On Emission Controls.	0330045				Unit 006
75.35	Missing Data Procedures for CO2	0330045	✓			Unit 006
75.36	Missing Data Procedures for Heat Input	0330045	✓			Unit 006
Subpart E — Alternative Monitoring Systems						
75.40	General Demonstration Requirements.	0330045				Unit 006
75.41	Precision Criteria.	0330045				Unit 006
75.42	Reliability Criteria.	0330045				Unit 006
75.43	Accessibility Criteria.	0330045				Unit 006
75.44	Timeliness Criteria.	0330045				Unit 006
75.45	Daily Quality Assurance Criteria.	0330045				Unit 006
75.46	Missing Data Substitution Criteria.	0330045				Unit 006
75.47	Criteria for a Class of Affected Units.	0330045				Unit 006
75.48	Petition for an Alternative Monitoring System.	0330045				Unit 006
Subpart F — Recordkeeping Requirements						
75.50	General Recordkeeping Provisions.	0330045	✓			Unit 006
75.51	General Recordkeeping Provisions for Specific Situations.	0330045				Unit 006
75.52	Certification, Quality Assurance, and Quality Control Record Provisions.	0330045	✓			Unit 006
75.53	Monitoring Plan.	0330045	✓			Unit 006
75.54	General Recordkeeping Provisions	0330045	✓			Unit 006
75.55	General Recordkeeping Provisions for Special Situations	0330045	✓			Unit 006

EPA Rule	GULF POWER - CRIST UNIT 6 EPA APPLICABLE REQUIREMENTS LIST EPA Title	(AIRS) Facility Emission Unit Identification Number(s)	Applicable Requirement		Comments/Discussion	Unit/Facility Potential Applicability
			Yes	No/NA		
75.56	Certification, Quality Assurance and Quality Control Record Provision	0330045	✓			Unit 006
Subpart G — Reporting Requirements						
75.60	General Provisions.	0330045	✓			Unit 006
75.61	Notification of Certification and Recertification Test Dates.	0330045	✓			Unit 006
75.62	Monitoring Plan.	0330045	✓			Unit 006
75.63	Certification or Recertification Applications.	0330045	✓			Unit 006
75.64	Quarterly Reports.	0330045	✓			Unit 006
75.65	Opacity Reports.	0330045	✓			Unit 006
Appendix A to Part 75 — Specifications and Test Procedures		0330045	✓			Unit 006
Appendix B to Part 75 — Quality Assurance and Quality Control Procedures		0330045	✓			Unit 006
Appendix C to Part 75 — Missing Data Statistical Estimation Procedures		0330045	✓			Unit 006
Appendix D to Part 75 — Optional SO ₂ Emissions Data Protocol for Gas-Fired Units and Oil-Fired Units		0330045		-		Unit 006
Appendix E to Part 75 — Optional NO _x Emissions Estimation Protocol for Gas-Fired Peaking Units and Oil-Fired Peaking Units		0330045		-		Unit 006
EPA Part 76 - Acid Rain Nitrogen Oxides Emission Reduction Program						
76.5	NO _x Emission Limitations for Group 1 Boilers.	0330045	✓			Unit 006
76.8	Early Election for Group 1, Phase II Boilers.	0330045				Unit 006
76.9	Permit Applications and Compliance Plans.	0330045	✓			Unit 006
76.10	Alternative Emission Limitations.	0330045	✓			Unit 006
76.11	Emissions Averaging.	0330045	✓			Unit 006
76.12	Phase I NO _x Compliance Extensions.	0330045				Unit 006

EPA Rule	GULF POWER - CRIST UNIT 6 EPA APPLICABLE REQUIREMENTS LIST EPA Title	(AIRS) Facility Emission Unit Identification Number(s)	Applicable Requirement		Comments/Discussion	Unit/Facility Potential Applicability
			Yes	No/NA		
76.13	Compliance and Excess Emissions	0330045	✓			Unit 006
76.14	Monitoring, Recordkeeping, and Reporting.	0330045	✓		Cost reporting under 76.14 (c).	Unit 006
76.15	Test Methods and Procedures.	0330045	✓		Only if AEL is requested.	Unit 006
EPA Part 77 - Excess Emissions						
77.3	Offset Plans	0330045	✓			Unit 006
77.5(b)	Deduction of Allowances	0330045	✓			Unit 006
77.6	Excess Emission Penalties for SO2 and Nox; and	0330045	✓			Unit 006
EPA Part 82 - Protection Of Stratospheric Ozone						
Subpart B - Servicing of Motor Vehicle Air Conditioners						
82.34	Prohibitions.	0330045	✓			Facility
82.36	Approved refrigerant recycling equipment.	0330045	✓			Facility
82.38	Approved independent standards testing organizations.	0330045	✓			Facility
82.40	Technician training and certification.	0330045	✓			Facility
82.42	Certification, recordkeeping and public notification requirements.	0330045	✓			Facility
Subpart F - Recycling and Emissions Reduction						
82.154	Prohibitions.	0330045	✓			Facility
82.156	Required practice.	0330045	✓			Facility
82.158	Standards for recycling and recovery equipment.	0330045	✓			Facility
82.160	Approved equipment testing organizations.	0330045	✓			Facility
82.161	Technician certification.	0330045	✓			Facility
82.162	Certification by owners of recovery and recycling equipment.	0330045	✓			Facility

EPA Rule	GULF POWER - CRIST UNIT 6 EPA APPLICABLE REQUIREMENTS LIST EPA Title	(AIRS) Facility Emission Unit Identification Number(s)	Applicable Requirement		Comments/Discussion	Unit/Facility Potential Applicability
			Yes	No/NA		
82.164	Reclaimer certification.	0330045	✓			Facility
82.166(k)(m)	Reporting and recordkeeping requirements for owners/operators.	0330045	✓			Facility
40 CFR 279.72	Used Oil Regulations.	0330045	✓		Facility burns on-spec used oil.	Facility