



**JEFFERSON SMURFIT CORPORATION
D-GRAPHICS DIVISION**

0005413

August 9, 1994

3389 POWERS AVENUE
JACKSONVILLE, FL 32207
TELEPHONE: 904/733-4020
FAX: 904/733-4381

Mr. John C. Brown, Jr., P.E.
Administrator
Air Permitting and Standards
Florida Department of Environmental Protection
Twin Towers Office Building
2600 Blair Stone Road
Tallahassee, Florida 32399-2400

Re: D-Graphics Permit Amendments

RECEIVED
PER-MAIL ROOM
1994 AUG 10 AM 11:39

Dear Mr. Brown:

Enclosed is an "Application to Operate/Construct Air Pollution Sources," and a check for fees in the amount of \$7,500.00, with regard to existing Presses 4 and 5 at D-Graphics. In accordance with discussions between representatives of D-Graphics and the Department, we are relinquishing our Permit for Press No. 2 because it no longer exists. We will also withdraw that Part of our Petition currently pending before the Hearing Board with respect to Press No. 2 only. Once all permit issues for Presses No. 4 and 5 are resolved the balance of the Petition will be withdrawn.

Also enclosed are the following attachments to the Application:

- A - Diagram pertaining to the relocation of Press No. 4; flow chart of air to the incinerator; and topographical map.
- B - LAER determination made for Press 4 and 5, setting forth 95% destruction and 80% capture efficiency limits, as part of the Consent Final Judgement entered between the Company and the Department.
- C - Explanation of the values entered in Section III C and draft operating permits as support documents.
- D - Description of burner and catalyst beds on the incinerator.

If you have any questions or need additional information please do not hesitate to call. We are hoping to receive the approved permits as soon as possible so as to enable us to meet our customers' demands. Thank you again for your cooperation.

Very truly yours,

Douglas Turner
Plant Manager

cc: R. Steven Pace, Chief, Air Quality Division
Jim Manning

DT/jek



JSC/CCA

JEFFERSON SMURFIT CORPORATION AND
CONTAINER CORPORATION OF AMERICA
401 Alton Street, P.O. Box 276, Alton, IL 62002-2276

**Imprest
Check**

Scott City Bank & Trust
A Correspondent of **BOATMEN'S BANK**

8900187

Date:

August 5, 1994

0005413

Pay

Seven thousand and five hundred dollars and 00/100

Amount

****7,500.00

To the order of

Florida Dept. of Environmental Protection

Imprest Account
2nd Signature Required
if Over \$5,000.

THIS CHECK NOT VALID UNLESS PRESENTED FOR
PAYMENT WITHIN 180 DAYS FROM DATE OF ISSUE

Marilyn Glasec
1ST SIGNATURE

[Signature]
2ND SIGNATURE
FOR JEFFERSON SMURFIT CORPORATION

⑈8900187⑈

⑈081509902⑈

0100610337⑈

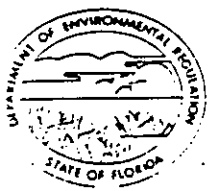

Florida Department of Environmental Regulation

Twin Towers Office Bldg. • 2600 Blair Stone Road • Tallahassee, Florida 32399-2400

AC 16-256153

PSD-FL-218

DER Form # _____
Form Title _____
Effective Date _____
DER Application No. _____

11/500 pcd
8-10-94
Recpt. # 224249

APPLICATION TO OPERATE/CONSTRUCT AIR POLLUTION SOURCES

SOURCE TYPE: Rotogravure Printing Press [] New [X] Existing

APPLICATION TYPE: [] Construction [] Operation [X] Modification

COMPANY NAME: D-Graphics, Div. of Jefferson Smurfit Corp. COUNTY: Duval

Identify the specific emission point source(s) addressed in this application (i.e. Lime Kiln No. 4 with Venturi Scrubber; Peaking Unit No. 2, Gas Fired)

SOURCE LOCATION: Street 3389 Powers Avenue City Jacksonville

UTM: East _____ North _____

Latitude 30 ° 15 ' 55 "N Longitude 81 ° 37 ' 18 "W

APPLICANT NAME AND TITLE: Douglas V. Turner, Plant Manager

APPLICANT ADDRESS: 3389 Powers Avenue, Jacksonville, Fl. 32207

SECTION I: STATEMENTS BY APPLICANT AND ENGINEER

A. APPLICANT

D-Graphics - Div. of

I am the undersigned owner or authorized representative* of Jefferson Smurfit Corp.

I certify that the statements made in this application for a Construction permit are true, correct and complete to the best of my knowledge and belief. Further, I agree to maintain and operate the pollution control source and pollution control facilities in such a manner as to comply with the provision of Chapter 403, Florida Statutes, and all the rules and regulations of the department and revisions thereof. I also understand that a permit, if granted by the department, will be non-transferable and I will promptly notify the department upon sale or legal transfer of the permitted establishment.

*Attach letter of authorization

Signed: Douglas V. Turner

Douglas V. Turner, Plant Manager
Name and Title (Please Type)

Date: 8-9-94 Telephone No. 904-733-4020

B. PROFESSIONAL ENGINEER REGISTERED IN FLORIDA (where required by Chapter 471, F.S.)

This is to certify that the engineering features of this pollution control project have been designed/examined by me and found to be in conformity with modern engineering principles applicable to the treatment and disposal of pollutants characterized in the permit application. There is reasonable assurance, in my professional judgment, that

1 See Florida Administrative Code Rule 17-2.100(57) and (104)

the pollution control facilities, when properly maintained and operated, will discharge an effluent that complies with all applicable statutes of the State of Florida and the rules and regulations of the department. It is also agreed that the undersigned will furnish, if authorized by the owner, the applicant a set of instructions for the proper maintenance and operation of the pollution control facilities and, if applicable, pollution sources.

Signed James L. Manning
James L. Manning
Name (Please Type)

Company Name (Please Type)
5077 Toproyal Lane, Jacksonville, Fl. 32211
Mailing Address (Please Type)

Florida Registration No. 36124 Date: 8-9-94 Telephone No. 904-744-7005

SECTION II: GENERAL PROJECT INFORMATION

A. Describe the nature and extent of the project. Refer to pollution control equipment, and expected improvements in source performance as a result of installation. State whether the project will result in full compliance. Attach additional sheet if necessary.

To relocate Press #4 adjacent to Press #5 (Refer to Attachment A), and include requirements of Presses #4 and #5 into one permit.

B. Schedule of project covered in this application (Construction Permit Application Only)

Start of Construction Upon Approval Completion of Construction Dec.31, 1994

C. Costs of pollution control system(s): (Note: Show breakdown of estimated costs only for individual components/units of the project serving pollution control purposes. Information on actual costs shall be furnished with the application for operation permit.)

Cost of reconfiguration of collection system duct work will be \$87,000.00.

No other changes to the existing control system is required.

D. Indicate any previous DER permits, orders and notices associated with the emission point, including permit issuance and expiration dates.

Press #4 AC 16-093347 AO 16-118644

Press #5 AC 16-089528 AO 16-118645

E. Requested permitted equipment operating time: hrs/day 24 ; days/wk 7 ; wks/yr 52 ;
if power plant, hrs/yr _____ ; if seasonal, describe: Normal operation of the equipment
is three shifts, 5-7 days per week, 52 weeks per year, with approximately 20% downtime
for cylinder changes, re-webbing, clean up, etc.

F. If this is a new source or major modification, answer the following questions.
(Yes or No)

- 1. Is this source in a non-attainment area for a particular pollutant? _____
 - a. If yes, has "offset" been applied? _____
 - b. If yes, has "Lowest Achievable Emission Rate" been applied? _____
 - c. If yes, list non-attainment pollutants. _____
- 2. Does best available control technology (BACT) apply to this source?
If yes, see Section VI. _____
- 3. Does the State "Prevention of Significant Deterioration" (PSD)
requirement apply to this source? If yes, see Sections VI and VII. _____
- 4. Do "Standards of Performance for New Stationary Sources" (NSPS)
apply to this source? _____
- 5. Do "National Emission Standards for Hazardous Air Pollutants"
(NESHAP) apply to this source? _____

- H. Do "Reasonably Available Control Technology" (RACT) requirements apply
to this source? _____
- a. If yes, for what pollutants? _____
 - b. If yes, in addition to the information required in this form,
any information requested in Rule 17-2.650 must be submitted.

Attach all supportive information related to any answer of "Yes". Attach any justifi-
cation for any answer of "No" that might be considered questionable.

SEE ATTACHMENT B

SECTION III: AIR POLLUTION SOURCES & CONTROL DEVICES (Other than Incinerators)

A. Raw Materials and Chemicals Used in your Process, if applicable:

Description	Contaminants		Utilization Rate - lbs/hr	Relate to Flow Diagram
	Type	% Wt		
Paper				Presses 4 & 5
Coatings	VOC	54	295.4	Presses 4 & 5
Solvents	VOC	100	346.7	Presses 4 & 5

B. Process Rate, if applicable: (See Section V, Item 1)

- Total Process Input Rate (lbs/hr): _____
- Product Weight (lbs/hr): _____

C. Airborne Contaminants Emitted: (Information in this table must be submitted for each emission point, use additional sheets as necessary)

Name of Contaminant	Emission ¹		Allowed Emission Rate per Rule 17-2	Allowable Emission lbs/hr	Potential ⁴ Emission		Relate to Flow Diagram
	Maximum lbs/hr	Actual T/yr			lbs/hr	T/yr	
VOC	154.1	556.3	--	--	642.1	2318.0	
(See Attachment C)							

¹See Section V, Item 2.

²Reference applicable emission standards and units (e.g. Rule 17-2.600(5)(b)2. Table II, E. (1) - 0.1 pounds per million BTU heat input)

³Calculated from operating rate and applicable standard.

⁴Emission, if source operated without control (See Section V, Item 3).

D. Control Devices: (See Section V, Item 4)

Name and Type (Model & Serial No.)	Contaminant	Efficiency	Range of Particles Size Collected (in microns) (If applicable)	Basis for Efficiency (Section V Item 5)
Dentrol	VOC	95%	--	Past Testing
20,000 SCFM				
(See Attachment D)				

E. Fuels

Type (Be Specific)	Consumption*		Maximum Heat Input (MMBTU/hr)
	avg/hr	max./hr	
Natural Gas			
(Press #4 & #5 Combined)	0.0067	0.0092	11.2 (At start-up)
Control Device	0.0027	0.0045	6.0

*Units: Natural Gas--MMCF/hr; Fuel Oils--gallons/hr; Coal, wood, refuse, other--lbs/hr.

Fuel Analysis:

Percent Sulfur: -0- Percent Ash: -0-

Density: --- lbs/gal Typical Percent Nitrogen: ---

Heat Capacity: 1042 BTU/CF BTU/lb --- BTU/gal

Other Fuel Contaminants (which may cause air pollution): ---

F. If applicable, indicate the percent of fuel used for space heating.

Annual Average --- Maximum ---

G. Indicate liquid or solid wastes generated and method of disposal.

None

H. Emission Stack Geometry and Flow Characteristics (Provide data for each stack):

Stack Height: 39 ft. Stack Diameter: 4.17 ft.
 Gas Flow Rate: 30,868 ACFM 20,000 DSCFM Gas Exit Temperature: 358 °F.
 Water Vapor Content: Varies % Velocity: 37.73 FPS

SECTION IV: INCINERATOR INFORMATION

Type of Waste	Type 0 (Plastics)	Type I (Rubbish)	Type II (Refuse)	Type III (Garbage)	Type IV (Pathological)	Type V (Liq. & Gas By-prod.)	Type VI (Solid By-prod.)
Actual lb/hr Incinerated							
Uncontrolled (lbs/hr)							

Description of Waste _____

Total Weight Incinerated (lbs/hr) _____ Design Capacity (lbs/hr) _____

Approximate Number of Hours of Operation per day _____ day/wk _____ wks/yr. _____

Manufacturer _____

Date Constructed _____ Model No. _____

	Volume (ft) ³	Heat Release (BTU/hr)	Fuel		Temperature (°F)
			Type	BTU/hr	
Primary Chamber					
Secondary Chamber					

Stack Height: _____ ft. Stack Diameter: _____ Stack Temp. _____

Gas Flow Rate: _____ ACFM _____ DSCFM* Velocity: _____ FPS

*If 50 or more tons per day design capacity, submit the emissions rate in grains per standard cubic foot dry gas corrected to 50% excess air.

Type of pollution control device: Cyclone Wet Scrubber Afterburner
 Other (specify) _____

Brief description of operating characteristics of control devices: _____

Ultimate disposal of any effluent other than that emitted from the stack (scrubber water, ash, etc.):

NOTE: Items 2, 3, 4, 6, 7, 8, and 10 in Section V must be included where applicable.

SECTION V: SUPPLEMENTAL REQUIREMENTS

Please provide the following supplements where required for this application.

1. Total process input rate and product weight -- show derivation [Rule 17-2.100(127)]
2. To a construction application, attach basis of emission estimate (e.g., design calculations, design drawings, pertinent manufacturer's test data, etc.) and attach proposed methods (e.g., FR Part 60 Methods 1, 2, 3, 4, 5) to show proof of compliance with applicable standards. To an operation application, attach test results or methods used to show proof of compliance. Information provided when applying for an operation permit from a construction permit shall be indicative of the time at which the test was made.
3. Attach basis of potential discharge (e.g., emission factor, that is, AP42 test).
4. With construction permit application, include design details for all air pollution control systems (e.g., for baghouse include cloth to air ratio; for scrubber include cross-section sketch, design pressure drop, etc.)
5. With construction permit application, attach derivation of control device(s) efficiency. Include test or design data. Items 2, 3 and 5 should be consistent: actual emissions = potential (1-efficiency).
6. An 8 1/2" x 11" flow diagram which will, without revealing trade secrets, identify the individual operations and/or processes. Indicate where raw materials enter, where solid and liquid waste exit, where gaseous emissions and/or airborne particles are evolved and where finished products are obtained.
7. An 8 1/2" x 11" plot plan showing the location of the establishment, and points of airborne emissions, in relation to the surrounding area, residences and other permanent structures and roadways (Example: Copy of relevant portion of USGS topographic map).
8. An 8 1/2" x 11" plot plan of facility showing the location of manufacturing processes and outlets for airborne emissions. Relate all flows to the flow diagram.

9. The appropriate application fee in accordance with Rule 17-4.05. The check should be made payable to the Department of Environmental Regulation.
10. With an application for operation permit, attach a Certificate of Completion of Construction indicating that the source was constructed as shown in the construction permit.

SECTION VI: BEST AVAILABLE CONTROL TECHNOLOGY

A. Are standards of performance for new stationary sources pursuant to 40 C.F.R. Part 60 applicable to the source?

Yes No

Contaminant

Rate or Concentration

Contaminant	Rate or Concentration

B. Has EPA declared the best available control technology for this class of sources (If yes, attach copy)

Yes No

Contaminant

Rate or Concentration

Contaminant	Rate or Concentration

C. What emission levels do you propose as best available control technology?

Contaminant

Rate or Concentration

Contaminant	Rate or Concentration

D. Describe the existing control and treatment technology (if any).

1. Control Device/System:

2. Operating Principles:

3. Efficiency:*

4. Capital Costs:

*Explain method of determining

5. Useful Life:

6. Operating Costs:

7. Energy:

8. Maintenance Cost:

9. Emissions:

Contaminant

Rate or Concentration

Contaminant	Rate or Concentration

10. Stack Parameters

- a. Height: ft.
- b. Diameter: ft.
- c. Flow Rate: ACFM
- d. Temperature: °F.
- e. Velocity: FPS

E. Describe the control and treatment technology available (As many types as applicable, use additional pages if necessary).

1.

- a. Control Device:
- b. Operating Principles:
- c. Efficiency:¹
- d. Capital Cost:
- e. Useful Life:
- f. Operating Cost:
- g. Energy:²
- h. Maintenance Cost:
- i. Availability of construction materials and process chemicals:
- j. Applicability to manufacturing processes:
- k. Ability to construct with control device, install in available space, and operate within proposed levels:

2.

- a. Control Device:
- b. Operating Principles:
- c. Efficiency:¹
- d. Capital Cost:
- e. Useful Life:
- f. Operating Cost:
- g. Energy:²
- h. Maintenance Cost:
- i. Availability of construction materials and process chemicals:

¹Explain method of determining efficiency.
²Energy to be reported in units of electrical power - KWH design rate.

- j. Applicability to manufacturing processes:
- k. Ability to construct with control device, install in available space, and operate within proposed levels:

3.

- a. Control Device:
- b. Operating Principles:
- c. Efficiency:¹
- d. Capital Cost:
- e. Useful Life:
- f. Operating Cost:
- g. Energy:²
- h. Maintenance Cost:
- i. Availability of construction materials and process chemicals:
- j. Applicability to manufacturing processes:
- k. Ability to construct with control device, install in available space, and operate within proposed levels:

4.

- a. Control Device:
- b. Operating Principles:
- c. Efficiency:¹
- d. Capital Costs:
- e. Useful Life:
- f. Operating Cost:
- g. Energy:²
- h. Maintenance Cost:
- i. Availability of construction materials and process chemicals:
- j. Applicability to manufacturing processes:
- k. Ability to construct with control device, install in available space, and operate within proposed levels:

F. Describe the control technology selected:

- 1. Control Device:
- 2. Efficiency:¹
- 3. Capital Cost:
- 4. Useful Life:
- 5. Operating Cost:
- 6. Energy:²
- 7. Maintenance Cost:
- 8. Manufacturer:
- 9. Other locations where employed on similar processes:
 - a. (1) Company:
 - (2) Mailing Address:
 - (3) City:
 - (4) State:

¹Explain method of determining efficiency.

²Energy to be reported in units of electrical power - KWH design rate.

(5) Environmental Manager:

(6) Telephone No.:

(7) Emissions:¹

Contaminant

Rate or Concentration

(8) Process Rate:¹

b. (1) Company:

(2) Mailing Address:

(3) City:

(4) State:

(5) Environmental Manager:

(6) Telephone No.:

(7) Emissions:¹

Contaminant

Rate or Concentration

(8) Process Rate:¹

10. Reason for selection and description of systems:

¹Applicant must provide this information when available. Should this information not be available, applicant must state the reason(s) why.

SECTION VII - PREVENTION OF SIGNIFICANT DETERIORATION

A. Company Monitored Data

1. _____ no. sites _____ TSP _____ () SO₂* _____ Wind spd/dir

Period of Monitoring _____ / _____ / _____ to _____ / _____ / _____
month day year month day year

Other data recorded _____

Attach all data or statistical summaries to this application.

*Specify bubbler (B) or continuous (C).

2. Instrumentation, Field and Laboratory

- a. Was instrumentation EPA referenced or its equivalent? Yes No
- b. Was instrumentation calibrated in accordance with Department procedures?
 Yes No Unknown

B. Meteorological Data Used for Air Quality Modeling

- 1. _____ Year(s) of data from _____ / _____ / _____ to _____ / _____ / _____
month day year month day year
- 2. Surface data obtained from (location) _____
- 3. Upper air (mixing height) data obtained from (location) _____
- 4. Stability wind rose (STAR) data obtained from (location) _____

C. Computer Models Used

- 1. _____ Modified? If yes, attach description.
- 2. _____ Modified? If yes, attach description.
- 3. _____ Modified? If yes, attach description.
- 4. _____ Modified? If yes, attach description.

Attach copies of all final model runs showing input data, receptor locations, and principle output tables.

D. Applicants Maximum Allowable Emission Data

Pollutant	Emission Rate
TSP	_____ grams/sec
SO ²	_____ grams/sec

E. Emission Data Used in Modeling

Attach list of emission sources. Emission data required is source name, description of point source (on NEDS point number), UTM coordinates, stack data, allowable emissions, and normal operating time.

F. Attach all other information supportive to the PSD review.

G. Discuss the social and economic impact of the selected technology versus other applicable technologies (i.e., jobs, payroll, production, taxes, energy, etc.). Include assessment of the environmental impact of the sources.

H. Attach scientific, engineering, and technical material, reports, publications, journals, and other competent relevant information describing the theory and application of the requested best available control technology.

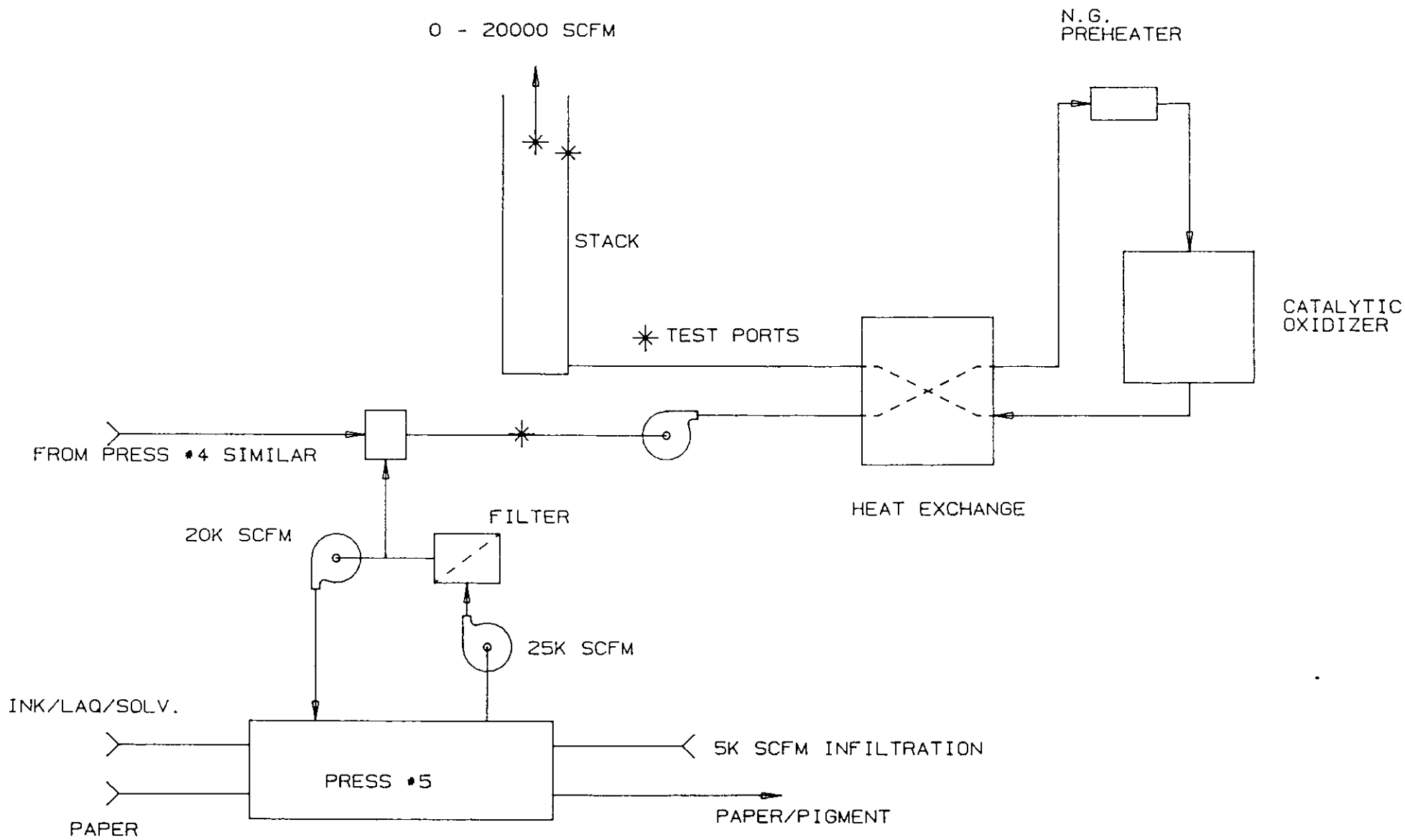

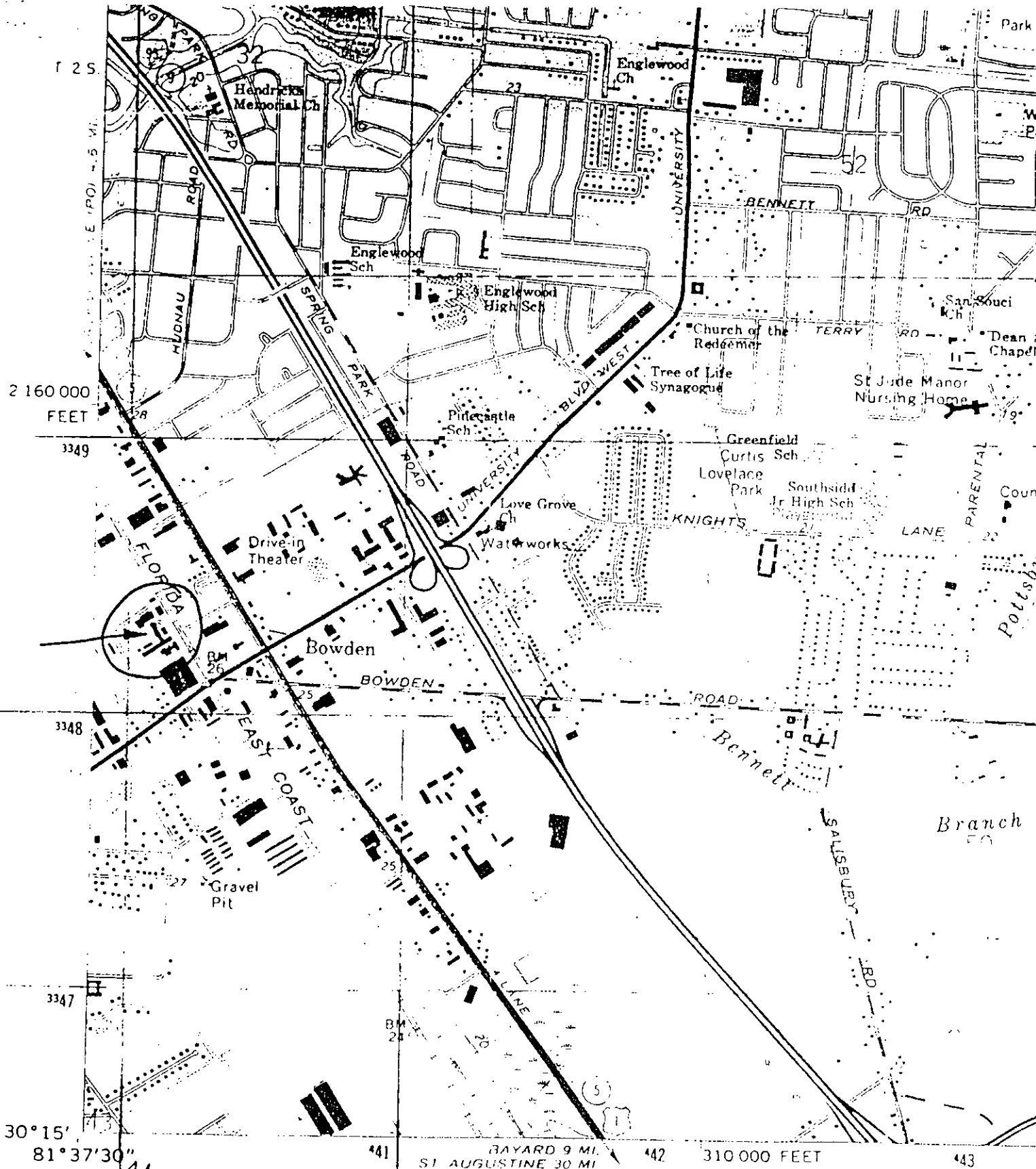

Mapped, edited, and published by the Geological Survey

Control by USGS, NOS/NOAA, and Florida Geodetic Survey

Planimetry compiled from NOS charts 1933. Topography from
 plane-table surveys 1948. Revised by photogrammetric methods
 from aerial photographs taken 1963. Field checked 1963

Selected hydrographic data compiled from NOS chart 577 (1963)
 This information is not intended for navigational purposes

Polyconic projection. 10,000-foot grid ticks based on Florida
 coordinate system, east zone. 1000-meter Universal Transverse
 Mercator grid ticks, zone 17, shown in blue. 1927 North

ARLINGTON
QUADRANGLE

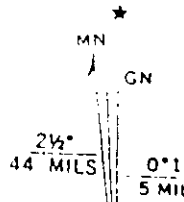

COAST GUARD PARK
 34 II NW

Lowest Achievable Emission Rate (LAER) Determination
Austill Packaging
Division of Smurfit Industries
Duval County

The applicant has installed an Intaroto eight color rotogravure press at their Jacksonville facility. The unit, Press No. 5, is used to print labels for various consumer goods. The substrate for the labels may be paper or foil laminated to paper. The press is scheduled to operate 6000 hours per year.

The rotogravure printing process uses a steel cylinder upon which an image has been engraved. The cylinder rotates in an ink trough. The inked image is transferred directly to the substrate by impression. The product is then dried. Basically, the process is the application of a relatively high solvent content ink to the surface of a moving web or film, then rapid solvent evaporation using heated air. The solvent-laden air is exhausted from the system.

The solvent-laden air, containing volatile organic solvents (VOC's) when discharged to the atmosphere, contributes significantly to air pollution which may reasonably be anticipated to endanger public health or welfare. VOC emissions are most significant as air pollutants in their role of photochemical oxidant precursors.

The dryer is the major source of VOC emissions with lesser amounts emitted at the ink fountain, the press, and the chill rolls. Vapor capture systems are necessary to minimize fugitive solvent vapor loss around the ink fountain and at the chill rolls. VOC emissions can also be reduced by using low solvent technology inks, if compatible with the planned line substrate.

The Austill Packaging plant is located in Duval County which is classified nonattainment for the pollutant ozone (VOC), Rule 17-2.410. The additional press will result in an ozone (VOC) emission increase above the significant emission rate and is considered to be a modification to a major facility thus subject to the provisions of Rule 17-2.510(2)(d)4.a. The application and employment of Lowest Achievable Emission Rate (LAER) is a preconstruction review requirement (Rule 17-2.510(4)(a)). The procedure for determining LAER is set forth in Section 17-2.640.

LAER Determination Requested by the Applicant:

Enclosures and ducts will be installed to capture 80 percent of the VOC vapors emitted at the press. The vapors will be conveyed to a new catalytic incinerator designed to convert 92-95 percent of the VOC's to innocuous CO₂ and water by rapid oxidation.

Date of Receipt of a LAER application:

November 15, 1984

Review Group Members:

The determination was based upon comments received from the New Source Review Section, the Northeast District Office, Jacksonville Division of Bio-Environmental Services, the Bureau Chief and Deputy Bureau Chief-Bureau of Air Quality Management, and USEPA-Region IV.

LAER Determined by DER:

Pollutant	Emission Limit
Ozone (VOC)	80 percent capture efficiency of the VOC vapors emitted at the press and 95 percent destruction of the collected VOC vapors by the catalytic incinerator.

LAER Determination Rationale:

In rotogravure printing from stationary sources, volatile organic compounds (VOC's) can be released to the atmosphere by evaporation from the inking, cleaning, and curing operations. Hydrocarbons comprise a class of VOC's containing only carbon and hydrogen in various combinations. Most of these compounds and their by-products are considered poisonous, but most are harmful only in very high concentrations. Hydrocarbons can react with other chemicals, notably in the photochemical reaction, which results in the oxidants commonly called smog.

To control VOC emissions the applicant first considered using waterborne inks instead of organic solvent inks. They experimented with waterborne inks but concluded that, even though promising, waterborne inks are not yet well enough developed for their printing requirements. Only add-on control devices remain for consideration.

The three most popular types of add-on devices are those for thermal and catalytic incineration or carbon absorption.

- o Carbon absorption: The solvent laden air is passed through a bed of activated carbon. The solvent is absorbed onto the carbon. The solvent is recovered by steam desorption, condensation, and decantation. The applicant's printing products vary in color and substrate, which require different solvents, some of which are not amenable to this type of control technology. The department agrees, that in this case, carbon absorption is not the recommended control technology.

- o Incineration: The solvent-laden air is heated to ignition temperatures, burning the solvent vapors to carbon dioxide and water. Catalytic oxidation or thermal oxidation are two suitable methods and allows heat to be recovered from the exhaust gases. There are some rotogravure operations that use complex solvent mixtures. For such operations thermal incineration may be the most feasible control method, which is the case at press No. 5.

The applicant will use a catalytic incinerator to reduce by 95% the amount of VOC's discharged to the atmosphere when press 5 is operating. The add-on unit will be a ComCat catalytic incinerator manufactured by Pillar Corporation. The applicant will install the necessary enclosures and ducting at press 5 to capture 80 percent of the vapors generated. The VOC destruction efficiency of the catalytic incinerator will be 95%. The planned incinerator and press ducting modifications will result in 250 less tons of VOC's discharged into the atmosphere per year.

The Department, when preparing a Lowest Achievable Emission Rate (LAER) determination, shall give consideration to and make a determination that reflects: 1) any information published by the USEPA, including the BACT/LAER Clearinghouse, 2) the most stringent emission limitation which is contained in the implementation plan of any state, 3) the most stringent emission limitation which is achieved in practice, and 4) all scientific, engineering, technical material, or other relevant information available to the department.

The latest (May 1984) BACT/LAER Clearinghouse summary lists data for eight facilities in the graphic arts category, half of which are rotogravure systems. Most of the efficiencies reported were based on a stack test for the control device and did not include the capture efficiency of the vapors generated at the emission point. At one of the listed facilities a material balance around the control device and vapor collection system was done. The control device efficiency was 95% and the capture efficiency was 73%. This facility did not have to meet LAER. A control device destruction efficiency of 95% with a capture efficiency of 85% was recommended as LAER for Press 5 by PEDCO Environmental Inc.

The literature research indicates that a 95% destruction efficiency of a catalytic incinerator is obtainable and judged to be LAER. The efficiency of a vapor capture system is still debatable especially in the case where such a system was not considered in the original source design. The department has judged that the 80% capture efficiency proposed by the applicant is LAER. However, if the applicant can demonstrate that the system was properly installed, operated and maintained, and through compliance testing that the 95% efficiency cannot be achieved because it is beyond the limit of the technology of the DER approved system, the applicant can apply for a modification of the LAER for a lower efficiency of not less than 92%. If

application for such modification is filed within 60 days of the compliance test showing an efficiency of less than 95%, then during the pendency of such application, the facility can be operated provided that the efficiency shall not be less than 92%, and provided however, the system has been properly installed and is being properly operated and maintained.

Details of the Analysis May be Obtained by Contacting:

Edward Palagyi, LAER Coordinator
Department of Environmental Regulation
Bureau of Air Quality Management
2600 Blair Stone Road
Tallahassee, Florida 32301

Recommended By:

C. H. Fancy

C. H. Fancy, Deputy Bureau Chief

Date: 2/12/85

Approved:

Victoria J. Tschinkel

Victoria J. Tschinkel, Secretary

Date: 2/18/85

January 4, 1985

IN THE CIRCUIT COURT OF THE
FOURTH JUDICIAL CIRCUIT, IN AND
FOR DUVAL COUNTY, FLORIDA

STATE OF FLORIDA DEPARTMENT
OF ENVIRONMENTAL REGULATION
and CITY OF JACKSONVILLE,
a municipal corporation, by
and through Donald C. Bayley,
Chief, Bio-Environmental
Services Division,

Plaintiffs,

vs.

Case No.: 83-138-54 CA
Division D

SMURFIT INDUSTRIES, INC.
a Delaware corporation,
d/b/a AUSTILL PACKAGING,

OGC File No: 83-0374

Defendant.

STIPULATION AND MOTION FOR ENTRY
OF CONSENT FINAL JUDGEMENT

This stipulation is made and entered into between Plaintiffs, State of Florida Department of Environmental Regulation ("Department") and the City of Jacksonville ("City") and Defendant Jefferson Smurfit Corporation. In addition, the United States Environmental Protection Agency ("E.P.A.") joins in this stipulation to resolve its claim against Austill for non-compliance penalties under Section 120 of the 1977 Clean Air Act.

The parties to this stipulation agree to the following findings and conditions for entry of a final judgement in the above-styled case, upon being approved and adopted by the Court.

FINDINGS OF FACT

1. The Department is the agency of the State of Florida authorized and required by Chapter 403, Florida Statutes, to control and prohibit air pollution in accordance with state laws and the rules promulgated thereunder.
2. The City of Jacksonville is a municipal corporation of the state of Florida. Through its agent, Bio-Environmental Services

Division ("BES"), the City is charged with the implementation and enforcement of City ordinances regarding control and regulation of environmental quality within the City.

3. Jefferson Smurfit Corporation, a Delaware corporation, is successor by merger to Smurfit Industries, Inc., the named Defendant. Jefferson Smurfit Corporation stipulates that it is a proper party to this action.

4. Through a division known as Austill Packaging ("Austill"), Jefferson Smurfit Corporation owns and operates a facility located at 3389 Powers Avenue in Jacksonville, Florida. The Austill facility converts rotogravure printed roll label stock using four rotogravure presses and one laminating press. The printing process utilizes inks and adhesives which contain solvents, resulting in the emission of volatile organic compounds (VOCs) into the atmosphere. The actual VOC emissions from the facility have exceeded 100 tons per year.

5. VOCs react in the atmosphere with other compounds to form the air pollutant ozone. The facility is located in an area which has been designated by the Department and the United States Environmental Protection Agency as nonattainment for ozone.

6. Of the five presses utilized by Austill, four presses (Press No. 1, the laminating press and Presses Nos. 2, 3 and 4, rotogravure presses) are subject to the Department's VOC rules for existing sources in a nonattainment area. Press No. 1 is subject to Rule 17-2.650(1)(f)3., Florida Administrative Code ("F.A.C."), and presses Nos. 2, 3 and 4 are subject to Rule 17-2.650(1)(f)16., F.A.C. These rules required existing sources to use either low solvent inks or an incineration system to control VOC emissions by October 1, 1982 (for Press No. 1) or December 31, 1982 (for Presses Nos. 2, 3, and 4).

7. In conjunction with its ink and adhesive supplier, Austill has tested numerous low solvent or water-based inks over the past several years, but has still not achieved compliance with the limits set forth in the Department rules noted above. On March 31, 1983, Austill applied with the Department for a variance

from the requirements of Rule 17-2.16(6)p., F.A.C. (renumbered Rule 17-2.650(1)(f)16.). The variance application was withdrawn by Austill after discussions with the Department on the appropriateness of a variance.

8. On August 13, 1981, Austill applied to the Department for a permit to construct Press No. 5 and advised the Department that Press No. 5 would operate solely on water-based (as opposed to solvent-based) inks. Press No. 5, a rotogravure printing press, was installed at the Austill facility in the first quarter of 1982.

9. Permit No. AC16-46844 was issued to Austill on January 7, 1982 for the construction of Press No. 5 using water-based inks. Specific Condition No. 1 of the permit states that maximum allowable VOC emissions from Press No. 5 shall be limited to 15 tons a year. Austill has failed to comply with this condition and has continuously operated Press No. 5 using solvent-based inks. Emissions of VOCs from Press No. 5 are in excess of 100 tons a year.

10. Permit No. AC16-46844 expired on April 30, 1982. Austill did not apply for or receive an extension of the construction permit or a permit to operate Press No. 5.

11. Press No. 5 is a new source of VOCs which is subject to Department Rules 17-2.640 (Lowest Achievable Emission Rate) and 17-2.510 (New Source Review for Nonattainment Areas), F.A.C. Under these rules, Austill was and is required to apply to Press No. 5 the lowest achievable emission rate ("LAER"), as determined by the Department in conjunction with an adequate construction permit application.

12. Austill has operated Press No. 5 without controlling VOC emissions through the use of either low solvent inks or an incinerator system to capture and combust the VOCs.

13. On July 2, 1984, Austill applied with the Department for a permit to construct an incinerator and capture system to control VOC emissions from Press No. 5.

CONDITIONS

In order to resolve this matter without the necessity of litigation, the Department, the City, EPA and the Defendant agree to the following conditions:

A. Defendant Jefferson Smurfit Corporation agrees to pay the sum of \$62,000 in settlement of the Department's and the City's claims for damages, costs and expenses and \$38,130.34 in settlement of the Department's and E.P.A.'s claims for civil penalties and non-compliance penalties, respectively. The said amount for payment of the E.P.A. Claims is the subject of a separate consent agreement and Final Settlement Order. (copy attached). Of this \$38,130.34 the E.P.A. has agreed to credit \$19,065.17 to the State of Florida for the environmental enhancement and VOC awareness and reduction program for Duval County described in Paragraph A(1) below. The total amount, shall be paid within 15 days of Court approval of this stipulation in three amounts, \$62,000 made payable to the Florida Department of Environmental Regulation for deposit in Department's Pollution Recovery Fund which shall be utilized for air quality restoration, preservation, and enhancement purposes as specified in Paragraph A(1), \$19,065.17 made payable to the State of Florida, Department of Environmental Regulation for the use by the state of Florida to help fund a VOC pollution awareness and reduction program as specified in paragraph A(2), and \$19,065.17 payable to the United States Treasury.

(1) The \$19,065.17 credited to the State of Florida shall be utilized for the following environmental enhancement and VOC pollution awareness and reduction program for Duval County. The purpose of the program will be to show the public how tampering or misfueling motor vehicles contributes to VOC emissions into the atmosphere and hence their contribution to ozone standard attainment problems in Duval County. The funds will be budgeted as follows:

\$10,000 - procurement of tail pipe analyzers
\$ 9,065.17 - conduct of program including public awareness

announcement so as to ensure maximum effectiveness.

The Department and the City agree to solicit assistance and support from health, environmental, and civic organizations and to use the \$9,065.17 for such organizations to conduct the program including a portion of the funds for public announcements so as to ensure maximum effectiveness of the program, and further agree not to use these funds for agency salary or to subplant costs of ongoing operations.

(2) The \$62,000 shall be utilized for a joint Department/City effort in monitoring air pollution and sources of air pollution in order to further reduce or encourage the reduction of air pollution or enforce the restoration of air quality. These funds will be budgeted as follows:

\$10,000	- Procurement of Portable Gas Chromatograph (GC) unit by the City
\$31,000	- Operation of the existing Finnagen GC/MS unit by the City
\$ 6,000	- Procurement of an Olfactometer - City
\$ 7,500	- Source inspections or equipment - Department for use in N.E. District.
\$ 7,500	- Source inspections or equipment - City
<hr/>	
\$62,000	

B. (1) For the control of VOCs from Presses Nos. 4 and 5, Austill commits to the installation of a system to capture and incinerate the VOCs through the use of either a catalytic or fume incinerator.

(2) The efficiency of the system for total removal of VOCs (including capture efficiency and other elements of control) from Press No. 5 shall be determined in accordance with Rule 17-2.640("LAER"), F.A.C., as part of the Department's determination on the construction permit application currently pending before the Department. The efficiency of the system for

total removal of VOCs from Press No. 4 has been determined in accordance with Rule 17-2.650(1)(f)16., F.A.C., also as part of the Department's determination on a construction permit application filed by Austill.

(3) Austill has submitted to the Department's Central Air Permitting Section and to the City's Bio-Environmental Services Division a detailed description and manufacturer's analysis of the type and brand of incinerator(s) which Austill proposes to use for Presses Nos. 4 and 5.

(4) Austill shall commit to the purchase of the incinerator(s) within 15 days of date of Court approval of this stipulation.

(5) Construction of the incinerator(s) shall be completed as soon as practicable, but no later than October 1, 1985.

(6) Austill shall respond to requests from the Department for further information with regard to the Presses Nos. 4 and 5 within 15 days of receipt of any such request or within 10 days of entry of this Order for those requests proceeding this Order.

C. Austill shall demonstrate final compliance with Rules 17-2.640 and 17-2.650(1)(f)16., F.A.C. for Presses Nos. 5 and 4, respectively, no later than December 31, 1985. The demonstration of final compliance shall be performed in accordance with paragraph 2 of Appendix A to this Stipulation, and shall be submitted to the Department, BES and EPA.

D. For the control of VOCs from Presses Nos. 1, 2, and 3, Austill shall abide by the schedule set forth in Appendix B for development of low solvent inks and adhesives and, if necessary, for installation of appropriate add-on control equipment.

E. Austill shall demonstrate final compliance with Rule 17-2.650(1)(f)3. F.A.C., for Press No. 1 no later than July 1, 1985. Austill shall demonstrate final compliance with Rule 17-2.650(1)(f)16., F.A.C., for Presses Nos. 2 and 3 no later than

December 31, 1985. If low solvent technology (or similar technology, such as use of inks with high solids content) is utilized, final compliance shall be demonstrated using the methods described in paragraph 1 of Appendix A. If an incineration system is employed to achieve compliance, the demonstration shall be made using the methods described in paragraph 2 of Appendix A.

F. Failure to meet the incremental compliance deadlines set forth in subparagraph B (6) and paragraph I, shall result in a stipulated penalty of \$50 per day for each day of non-compliance. Failure to meet the incremental compliance deadlines set forth in subparagraph B (4) and (5) shall result in a stipulated penalty of \$1,000 per day for each day of non-compliance. Failure to meet the incremental compliance deadlines set forth in Appendix B shall result in a stipulated penalty of \$250 per day for each day of non-compliance. All stipulated penalties shall be paid by money order or certified check on a weekly basis, 50% to be paid to the Department's Pollution Recovery Trust Fund and 50 % to the Air Pollution Control Trust Fund of the City of Jacksonville, Florida.

G. If Austill fails to achieve and demonstrate final compliance as set forth in paragraphs C and E above for any of the presses, Austill shall cease all operations on any non-complying presses until such time as the Department is assured that operation will not result in a violation of permit conditions or Department rules, or operation while out of compliance shall result in a civil penalty of \$5,000 per each day of operation of Presses No. 4 and (5) and \$2,500 per day for Presses Nos. 1, (2), and 3. The penalties are payable by cashier's check or money order on a weekly basis, 50 percent to be paid to the Department's Pollution Recovery Fund and 50 percent to the Air Pollution Control Trust Fund of the City of Jacksonville. Payment of the penalty shall not preclude the enforcement of the requirement to cease future operation of the press through appropriate action by the Court. Any penalty not voluntarily submitted in a timely manner shall be

doubled if compliance is effected through the seeking of an Order of the Court.

H. Austill shall submit monthly progress reports beginning 15 days after entry of this Stipulation by the Court and continuing every month until final compliance on all presses is achieved. The reports shall identify all efforts to comply with the terms of this Stipulation, including (1) research and development of LST, and (2) efforts to install, test and operate incineration equipment. The reports shall detail pounds of VOC/gallon of coating, excluding water, delivered to the coating applicator for Press No. 1, the percentage by volume of organic solvent in the volatile fraction of ink as it is applied to the substrate for Presses Nos. 2 and 3. The reports shall explain the method used for calculating these numbers using EPA Method 24. The reports shall be submitted no later than fifteen days after the beginning of the month in which they are due. Austill shall provide any raw data used in these calculations within 10 days of receipt of a written request by the Department.

I. All submissions of test results, reports, and other information required by this Stipulation shall be sent to the Department's Central Air Permitting Section, 2600 Blair Stone Road, Twin Towers Office Building, Tallahassee, Florida, 32301; and Northeast District Office, 3426 Bills Road, Jacksonville, Florida, 32207; the BRS, 515 West Sixth Street, Jacksonville, Florida 32206; and the U.S.E.P.A., Region IV, Director, Air, Pesticides and Toxics Management Division, 345 Courtland Street N.E., Atlanta, Georgia, 30308.

J. This Court shall retain jurisdiction over this cause pending compliance with the terms of this Stipulation. The Department and the City agree to entry of a final Judgment and Order incorporating the aforementioned in settlement of their claims in this case. The Department and the City retain the right, however, to move the Court for enforcement of the terms of this Stipulation

through the Court's use of contempt, an award of penalties, or other appropriate relief.

K. In addition to all other sanctions and penalties that may be imposed upon Austill for non compliance with the terms hereof, Austill agrees to pay reasonable attorneys fees and costs including appellate fees and costs necessarily incurred by the Department or BES in any successful enforcement action brought before this Court. The terms of this Judgment may be enforced by any signatory to the Consent Judgment.

L. It is the intent of the parties that there be strict compliance with construction and compliance deadlines. The parties understand that construction and compliance deadlines are to be met and enforced despite non-extraordinary contract, labor, transportation or similar problems affecting Austill. The parties likewise understand that extraordinary circumstances may arise that would compel agreement to modify this stipulation or that would justify judicial relief from the time limitations and penalties as set forth. These circumstances must be extraordinary, beyond Austill's reasonable control and not reasonably foreseeable by Austill. This stipulation shall not preclude Austill from seeking such judicial relief if the parties cannot agree upon appropriate modifications. If judicial relief is sought, Austill, shall have the burden of proof that the circumstances described above exist. If demonstrated by Austill, relief shall only be granted to the extent reasonably necessary to abate, avoid or remedy the extraordinary circumstances shown to exist.

M. Jefferson Smurfit Corporation neither admits nor denies herein any violation, noncompliance or liability based upon the allegations of the complaint or the facts found in this stipulation.

N. The parties agree to the dismissal of pending criminal litigation upon approval of this stipulation by the court.

Robert J. Stearley 1/4/85
Robert J. Stearley, Vice President Date
Jefferson Smurfit Corporation
P.O. Box 276
Alton, Illinois 62002

Phillip Parsons 1/4/85
Phillip Parsons, Attorney Date
for Jefferson Smurfit Corporation
227 S Calhoun
Tallahassee, Florida 32301

Donald C. Bayley 1/4/85
Donald C. Bayley Date
Bio-Environmental Services Division
City of Jacksonville, Florida
515 West 6th Street
Jacksonville, Florida 32206

GERALD A. SCHNEIDER
GENERAL COUNSEL

Steven E. Rohan 1/4/85
Steven E. Rohan Date
Assistant Counsel
1300 City Hall Jacksonville, Florida 32202
(904) 633-2460 Attorneys for City of Jacksonville
Bio-Environmental Services Division

John C. Bottcher 1/4/85
John C. Bottcher Date
Attorney
State of Florida Department
of Environmental Regulation
2600 Blair Stone Road
Tallahassee, FL 32301

Jewel Harper _____ Date
Attorney
U.S. Environmental Protection
Agency Region IV
345 Courtland
Atlanta, GA 30365

APPENDIX A

COMPLIANCE VERIFICATION

1. If compliance is to be achieved by using LST, then Austill shall demonstrate compliance using the following procedures:

(a) The volatile matter content, the water content, the density, the volume of solids and the weight of solids for each ink and lacquer shall be determined by EPA Method #24. The Method #24 results shall be compared to the manufacturer's specifications for that particular coating and both shall be submitted as part of the compliance verification package. Testing shall continue until such a time that the Department determines that there is an acceptable correlation between the Method #24 results and the manufacturer's specifications.

(b) The transfer efficiency shall be assumed to be 100 percent until demonstrated to the Department's satisfaction otherwise, thus no credit can be given for improved transfer efficiency.

(c) Any solvent used for make-up or dilution shall be included in the actual emissions. It will be assumed that 100 percent of this solvent is evaporated unless demonstrated to the Department's satisfaction that this is not the case.

(d) The solvent content of inks or adhesives may be averaged within the same RACT category (paper coating or graphic arts) for those presses utilizing LST. Compliance must be determined on a daily basis. This Order may be modified, however, to reflect any changes in EPA national policy that would allow averaging for time periods greater than daily.

2. If compliance using LST is deemed unlikely, then Austill shall demonstrate compliance using the following procedure:

(a) The efficiency of any add-on control equipment shall be established by a materials balance. The capture efficiency of the control equipment shall be based on the July 7, 1980 EPA memorandum entitled "Determination of Capture Efficiency", from James Berry to Doug Cook. The VOCs emitted from the control equipment shall be determined by an EPA method #25 test. The measured emissions and fugitive emissions, which were not captured by the control equipment, shall make up the actual emissions for a particular operation. Therefore, the efficiency of a piece of control equipment shall be one minus the actual emissions divided by the VOCs into the operation.

(b) Once the efficiency of the control equipment is established, the actual emissions from that operation on any given day shall be the penetration (one minus the efficiency) times the VOCs into the operation on that given day.

(c) The Department, BES and EPA shall be notified 15 days in advance of the Method #25 test and the notification shall be in writing.

(d) Where a single add-on control system (e.g. incineration) is utilized to control emissions for two operations having different emission standards, the most restrictive emission standard applies, unless demonstrated to the satisfaction of the respective agencies that compliance with separate standards can be adequately demonstrated without averaging or pro-rating the emissions.

APPENDIX B
INTERIM COMPLIANCE FOR PRESSES NOS, 1, 2 and 3

Press No. 1

1. Within ten days of entry of the consent order, Austill shall evaluate the likelihood of successfully meeting the July 1, 1985 deadline using LST and submit a report stating whether it intends to proceed with LST or whether it intends to rely on add-on controls as the method of compliance.

2. If compliance using LST or exempt solvents is deemed to be unlikely, Austill shall meet the following interim compliance deadlines:

(a) Within thirty days of entry of the consent order, Austill shall submit to the Department a complete application for installation on Press No. 1 of add-on VOC control equipment (e.g. incineration or carbon absorption) including the method of VOC capture to be utilized.

(b) Unless informed within 30 days after the application required by 2. (a) above of the unacceptability of the equipment proposed, Austill shall obtain a purchase order and a contract for installation of the equipment no later than 45 days after submission of the application. Proof of compliance with this provision shall be submitted to the Department within 60 days of submission of the application.

(c) Austill shall verify that construction of the VOC control and capture system is complete and submit the results of compliance tests no later than June 15, 1985.

Presses Nos. 2 and 3

3. By June 1, 1985, Austill shall evaluate the likelihood of successfully meeting the December 31, 1985, deadline for final compliance using LST and submit a report stating whether it intends to proceed with LST or whether it intends to rely on add-on controls as the method of compliance.

(a) If compliance using LST is deemed to be likely, Austill shall meet the following interim compliance deadlines:

(1) As expeditiously as practical but not later than July 31, 1985, Austill shall implement the commercial application of at least one low solvent coating material. Certification of implementation shall be provided in the following monthly report.

(b) If compliance using LST is deemed to be unlikely, Austill shall meet the following interim compliance deadlines:

(1) By June 15, 1985, Austill shall submit to the Department a complete application for installation of add-on VOC control equipment (e.g. afterburner, carbon absorption), including the method of VOC capture to be utilized.

(2) Unless informed by the Department by July 15, 1985, of the unacceptability of the equipment proposed, Austill shall obtain a purchase order and a contract for installation of the equipment no later than July 25, 1985. Proof of compliance with this provision shall be submitted to the Department by August 1, 1985.

(3) Austill shall verify that construction of the VOC control and capture system has been completed by October 1, 1985, and that the test reports demonstrating compliance shall be submitted by December 1, 1985.

Attachment C

D-Graphics, Jacksonville, Florida Construction Permit Application

III C. The values proposed for maximum actual emissions are the permitted values taken from the draft operating permit (copy attached) prepared by the City of Jacksonville. These values were established in negotiations between the City of Jacksonville and Austill Packaging, the previous owner of the facility, and continue reflect the operating conditions of the facility. Also attached is a copy of a letter dated December 31, 1987, to the City of Jacksonville from Austill's consultant confirming the agreement reached in negotiations regarding representative operating conditions.

The maximum actual tons per year figure of 556.3 is derived from the values in the draft operating permits for Presses #2, 4, and 5 proposed by FDEP on October 30, 1986, and subsequently redistributed in the above-mentioned negotiations to more accurately reflect actual operating conditions. As can be seen in the attached "Proposed Permit Conditions", D-Graphics is proposing to maintain this value (which is less than the total allowable emissions for the three presses), while increasing the allowable hours of run time for the presses. This can be accomplished by accepting a reduction in the allowable loading of VOCs to the substrate and a reduction in the allowable hourly mass emission rate.

PROPOSED PERMIT CONDITIONS

PARAMETERS -----	PROPOSED -----
RUN HOURS -----	
hrs/yr #4	7220
#5	7220

TOTALS	* 14440
SUBSTRATE LOADING -----	
(lbs./hr #4	282.5 (642.1x.44)
applied) #5	359.6 (642.1x.56)

TOTALS	642.1
EMISSION RATE -----	
lbs.hr #4	67.8
#5	86.3

TOTALS	154.1
EMISSIONS -----	
tons/yr #4	244.8
#5	311.5

TOTALS	556.3

* We propose a decrease in substrate loading lbs/hr while increasing the permitted run hours. The total permitted emission tons/yr will remain the same with some slight redistribution by press.



Florida Department of Environmental Regulation

Northeast District • 3426 Bills Road • Jacksonville, Florida 32207 • 904-798-4200

Bob Martinez, Governor

Dale Twachtmann, Secretary

John Shearer, Assistant Secretary
Ernest Frey, Deputy Assistant Secretary

Permittee:

D-Graphics

3389 Powers Avenue
Jacksonville, Florida 32207
DRAFT

I.D. Number:

31-16-0238-02

Permit/Certification Number:

AO16-118644

Date of Issue:

Expiration Date:

September 30, 1991

County:

Duval

Latitude/Longitude:

30:15:55/81:37:18

UTM:

E-7440.092 N-3348.280

Project:

Rotogravure Press No. 4

This permit is issued under the provisions of Chapter 403, Florida Statutes, and Florida Administrative Code Rules 17-2 and 17-4. The above named permittee is hereby authorized to perform the work or operate the facility shown on the application and approved drawing(s), plans, and other documents attached hereto or on file with the department and made a part hereof and specifically described as follows:

For the operation of Rotogravure Press No. 4 for the printing of packaging labels. Volatile organic compound (VOC) emissions shall be controlled through the use of a Pillar Catalytic Incinerator (Model P-15000) and associated VOC capture and transport equipment.

Located at 3389 Powers Avenue, Jacksonville, Florida 32207

Emission point(s) shall be as follows:

Point

02

Source

Rotogravure Press No. 4

Supporting documents shall be as follows:

- (1) Certificate of Completion of Construction form dated December 31, 1985
- (2) Additional information received on April 16, 1986
- (3) Waiver of 90 day time limit dated June 6, 1986
- (4) VOC emission tests dated July 25 and 26, 1986
- (5) BESD letter dated April 10, 1986 requesting additional information
- (6) Permit AC16-089528
- (7) Consent Final Judgement dated February 28, 1985
- (8) Lowest achievable Emission Rate Determination dated February 18, 1985
- (9) Environmental Science and Engineering, Inc. (ESE) letter dated November 30, 1987 and December 31, 1987
- (10) BESD letter dated November 23, 1987
- (11) Department of Environmental Regulation memorandum dated April 15, 1990

Permittee:

D-Graphics

I.D. Number:

Permit/Certification Number:

Date of Issue:

Expiration Date:

31-16-0238-02

AO16-118644

September 30, 1991

GENERAL CONDITIONS:

1. The terms, conditions, requirements, limitations, and restrictions set forth herein are "Permit Conditions" and as such are binding upon the permittee and enforceable pursuant to Sections 403.141, 403.727, or 403.855 through 403.861, Florida Statutes. The permittee is placed on notice that the Department will review this permit periodically and may initiate enforcement action for any violation of these conditions.
2. This permit is valid only for the specific processes and operations applied for and indicated in the approved drawings or exhibits. Any unauthorized deviation from the approved drawings, exhibits, specifications, or conditions of this permit may constitute grounds for revocation and enforcement action by the Department.
3. As provided in Subsections 403.087(6) and 403.722(5), Florida Statutes, the issuance of this permit does not convey any vested rights or any exclusive privileges. Neither does it authorize any injury to public or private property or any invasion of personal rights, nor any infringement of federal, state, or local laws or regulations. This permit is not a waiver of or approval of any other department permit that may be required for other aspects of the total project which are not addressed in this permit.
4. This permit conveys no title to land or water, does not constitute State recognition or acknowledgment of title, and does not constitute authority for the use of submerged lands unless herein provided and the necessary title or leasehold interests have been obtained from the state. Only the Trustees of the Internal Improvement Trust Fund may express State opinion as to title.
5. This permit does not relieve the permittee from liability for harm or injury to human health or welfare, animal, or plant life, or property caused by the construction or operation of this permitted source, or from penalties therefore nor does it allow the permittee to cause pollution in contravention of Florida Statutes and Department rules, unless specifically authorized by an order from the Department.
6. The permittee shall properly operate and maintain the facility and systems of treatment and control (and related appurtenances) that are installed and used by the permittee to achieve compliance with the conditions of this permit, as required by Department rules. This provision includes the operation of backup or auxiliary facilities or similar systems when necessary to achieve compliance with the conditions of the permit and when required by department rules.
7. The permittee, by accepting this permit, specifically agrees to allow authorized Department personnel, upon presentation of credentials or other documents as may be required by law, and at reasonable times, access to the premises where the permitted activity is located or conducted to:
 - a. Have access to and copy any records that must be kept under conditions of the permit;
 - b. Inspect the facility, equipment, practices, or operations regulated or required under this permit; and
 - c. Sample or monitor any substances or parameters at any location reasonably necessary to assure compliance with this permit or Department rules.

Reasonable time may depend on the nature of the concern being investigated.

8. If, for any reason, the permittee does not comply with, or will be unable to comply with any condition or limitation specified in this permit, the permittee shall immediately provide the Department with the following information:
 - a. A description of and cause of non-compliance; and
 - b. The period of non-compliance, including dates and times; or, if not corrected, the anticipated time the non-compliance is expected to continue, and steps being taken to reduce, eliminate, and prevent recurrence of the non-compliance.

Permittee:

D-Graphics

I.D. Number:

Permit/Certification Number:

Date of Issue:

Expiration Date:

31-16-0238-02

AO16-118644

September 30, 1991

9. In accepting this permit, the permittee understands and agrees that all reports, notes, monitoring data and other information relating to the construction or operation of this permitted source, which are submitted to the Department, may be used by the Department as evidence in any enforcement case involving the permitted source arising under the Florida Statutes or Department rules, except where such use is proscribed by Sections 403.111 and 403.73, Florida Statutes. Such evidence shall only be used to the extent it is consistent with the Florida Rules of Civil Procedure and appropriate evidentiary rules.
10. The permittee agrees to comply with changes in Department rules and Florida Statutes after a reasonable time for compliance; provided, however, the permittee does not waive any other rights granted by Florida Statutes or Department rules.
11. This permit is transferable only upon Department approval in accordance with Rules 17-4.120 and 17-30.300, FAC, as applicable. The permittee shall be liable for any non-compliance of the permitted activity until the transfer is approved by the Department.
12. This permit, or a copy thereof, shall be kept at the work site of the permitted activity.
13. This permit also constitutes:
 - () Determination of Best Available Control Technology (BACT)
 - () Determination of Prevention of Significant Deterioration (PSD)
 - () Certification of Compliance with State Water Quality Standards (Section 401, PL 92-500)
 - () Compliance with New Source Performance Standards
14. The permittee shall comply with the following:
 - a. Upon request, the permittee shall furnish all records and plans required under Department rules. During enforcement actions, the retention period for all records will be extended automatically unless otherwise stipulated by the Department.
 - b. The permittee shall hold at the facility, or other location designated by this permit, records of all monitoring information (including all calibration and maintenance records and all original strip chart recordings for continuous monitoring instrumentation), required by this permit, copies of all reports required by this permit, and records of all data used to complete the application for this permit. These materials shall be retained at least three years from the date of the sample, measurement, report, or application unless otherwise specified by Department rule.
 - c. Records of monitoring information shall include:
 - the date, exact place, and time of sampling or measurements;
 - the person responsible for performing the sampling or measurements;
 - the date(s) analyses were performed;
 - the person responsible for performing the analyses;
 - the analytical techniques or methods used; and
 - the results of such analyses
15. When requested by the Department, the permittee shall within a reasonable time furnish any information required by law which is needed to determine compliance with the permit. If the permittee becomes aware that relevant facts were not submitted or were incorrect in the permit application or in any report to the Department, such facts or information shall be submitted or corrected promptly.

Permittee:	I.D. Number:	31-16-0238-02
D-Graphics	Permit/Certification Number:	AO16-118644
	Date of Issue:	
	Expiration Date:	September 30, 1991

SPECIFIC CONDITIONS:

1. Permittee shall notify the Bio-Environmental Services Division (BESD) thirty (30) days prior to source testing.
2. Copies of the test report(s) shall be submitted to BESD within forty-five (45) days of completion of testing in accordance with Rule 17-2.700(7)(b), FAC, and Rule 2.501, JEPB.
3. Testing of emissions shall be accomplished at a minimum of 90% of the permitted capacity. If testing is performed at a rate less than 90% of the permitted capacity, operation shall be limited to a maximum of 110% of the tested capacity until such time as an acceptable test is performed at a minimum of 90% of the permitted capacity. When operation is restricted to a lower capacity because of testing at such a level, BESD, upon advanced notification, will allow operation at higher capacities if such operation is for demonstrating compliance at a higher capacity.
4. Any revision(s) to a permit (and application) shall be submitted and approved prior to implementing.
5. Control equipment shall be provided with a method of access that is safe and readily accessible.
6. Stack sampling facilities shall be required and shall comply with the requirements of Rule 17-2.700(4), (FAC), and Rule 2.207, JEPB.
7. Permittee shall submit an annual operation report to BESD for this source on the form supplied for each calendar year on or before March 1 in accordance with Rule 17-4.140, FAC.
8. The following pollutant(s) shall be tested at intervals indicated from the date of June 1, 1986:

<u>Pt. No.</u>	<u>Pollutant</u>	<u>Interval</u>
02	Volatile Organic Compounds (VOC)	12 Months

9. The applicable emission limiting rules shall be as follows:

<u>Pt. No.</u>	<u>Pollutant</u>	<u>¹FAC</u>	<u>²JEPB</u>
02	VOC	17-2.510(4)(a)	2.210

10. The maximum allowable emissions shall be as follows:

<u>Pt. No.</u>	<u>Pollutant</u>	<u>lbs/hr</u>	<u>T/yr</u>
02	VOC	61.31	177.49

11. Operation shall be limited to 5790 hours per year (run time).
12. The VOC applied to the substrate shall be limited to 255.46 pounds per hour.

Permittee:

D-Graphics

I.D. Number:

Permit/Certification Number:

Date of Issue:

Expiration Date:

31-16-0238-02

AO16-118644

September 30, 1991

13. The source is subject to the emission standards established through a determination of LAER by a Consent Judgement (dated February 28, 1985, Case No. 83-138-54, C A Division D), which requires 80% overall capture and transport efficiency of the VOC delivered to the substrate and 95% total destruction of all VOC delivered to the inlet of the catalytic incinerator.
14. Compliance testing shall be performed in accordance with the following test protocols. See Appendix A.
15. Rotogravure Press No. 4 shall be tested individually and collectively with any press(es) utilizing this control device.
16. The permittee shall apply for a renewal operation permit sixty (60) days prior to the expiration date of this permit in accordance with Rule 17-4.090, FAC. Failure to submit a renewal application sixty (60) days prior to the expiration date shall result in the assessment of a penalty in accordance with Section 360.701(a)19., Ordinance Code, City of Jacksonville.

City of Jacksonville
Department of Health, Welfare and
Bio-Environmental Services

State of Florida
Department of Environmental Regulation

James L. Manning, P.E., Deputy Director

Ernest E. Frey, P.E., Deputy Assistant Secretary

DRAFT

DRAFT

¹Florida Administrative Code

²Jacksonville Environmental Protection Board

APPENDIX A

- A. The capture efficiency of the VOC collection system and the destruction efficiency of the incinerator shall be determined by simultaneously measuring the amount of VOC introduced to the process, the amount of VOC captured as measured at the incinerator inlet, and the amount of VOC leaving the incinerator as measured at the incinerator outlet. All testing shall be done in accordance with U.S. EPA "Guidelines for Developing Capture Efficiency Protocols," March 13, 1990. Specific test procedures shall be as follows:

VOC introduced to the process	-	Procedure L
VOC captured (inlet)	-	Procedure G ₁
VOC emitted (outlet)	-	Procedure G ₁

VOC audit gases, as required pursuant to G₁, Section 5.4, will be provided by Bio-Environmental Services Division.

- B. If the permittee believes that a significant amount of the captured VOCs are oxidized in the ovens or in the exhaust recirculation system, the permittee may elect to conduct additional testing to determine the amount of captured VOCs being oxidized as follows:

Nomenclature

L =	Liquid phase VOC input.
G =	Gaseous phase captured VOC emissions measured by procedures G ₁ .
G _M =	Captured VOC emissions adjusted to an as-methane basis.
AF =	Adjustment factor, determined as the ratio of G(TOT)/G _M .
CO ₂ (NG) :	CO ₂ concentration at the incinerator inlet attributable to the natural gas burned as fuel in the drying ovens.
CO ₂ (AMB) :	CO ₂ concentration at the incinerator inlet attributable to the CO ₂ concentration in ambient air.
CO ₂ (VOC) :	CO ₂ concentration at the incinerator inlet attributable to gaseous phase captured VOC emissions oxidized in the ovens prior to reaching the incinerator.
G(TOT) =	Total captured VOC emissions at the incinerator inlet, determined as the sum of G _M and CO ₂ (VOC).
CO(TOT), CO ₂ (TOT) :	Total CO or CO ₂ measured at the incinerator inlet using EPA Method 25 analyses.

- (1) Using the procedures for single-point, integrated sampling from EPA reference method 3, obtain an integrated captured gas sample during each captured VOC pollutant determination. The sampling runs should be simultaneous with, and for the same total

length of time as, the captured VOC determination. These bags will be analyzed for $CO_2(TOT)$, $CO(TOT)$ by EPA reference method 25. This analysis is necessary to determine concentrations in the part per million range.

- (2) Following the sampling described above, bag standards of the solvents used during the testing will be prepared, based upon the solvent composition used during the test. Standards will be prepared according to the standards preparation procedure of EPA reference method 18 at a concentration level of 10,000 parts per million, to match the expected source concentration. Using the same FIA used in paragraph A above, the FIA will then be calibrated with methane standards, and the solvent bag standards will be analyzed. A relative response factor for solvent-to-methane basis conversion will thus be determined. Using this response factor, VOC concentrations determined at the incinerator inlet (G) will be adjusted to an as-methane basis - (G_M).
- (3) Meter the amount of natural gas (CH_4) burned in the dryer ovens during the period of the capture efficiency testing, paragraph A above. Based upon the volumetric flow rate at the incinerator inlet, calculate the concentration of carbon dioxide (CO_2) expected in the captured gas stream as a result of the oxidation of the methane in the natural gas fuel (CO_2NG).
- (4) Determine the CO_2 concentration in the ambient air (CO_2AMB) using sampling and analytical procedures required in paragraph A above. An air-cooled or water-cooled condenser to remove moisture is not required. Alternately, an ambient CO_2 concentration of 350 ppm may be assumed.
- (5) Calculate the concentration of captured VOCs oxidized prior to the incinerator (CO_2VOC) as follows: From the total CO and CO_2 concentrations at the incinerator inlet determined by paragraph 1, subtract the concentration of CO_2 resulting from combustion of natural gas fuel as determined by paragraph 3, and the ambient CO_2 concentration determined by paragraph 4. Any remainder is attributable to captured VOCs combusted in the ovens or exhaust recirculation system.

$$\text{Equation 1 : } CO_2VOC = CO_{TOT} + CO_2TOT - CO_2NG - CO_2AMB$$

- (6) Determine the total captured VOC emissions at the incinerator inlet - (G_{TOT}), by adding the captured VOC adjusted to an as-methane basis (G_M), and the CO_2 concentration at the incinerator attributable to captured VOC oxidized in the ovens $CO_2(VOC)$.

$$\text{Equation 2 : } G_{TOT} = G_M + CO_2(VOC)$$

- (7) Determine the VOC preincineration adjustment factor (AF), by dividing total captured VOCs G_{TOT} by captured VOC as-methane G_M .

$$\text{Equation 3 : } AF = \frac{G_{TOT}}{G_M}$$

- (8) Determine capture efficiency (CE) by multiplying captured gaseous phase VOC emissions (G) by the VOC preincineration adjustment factor AF, and divide the product by the liquid VOC input (L).

$$\text{Equation 4 : } CE = \frac{G \times AF}{L}$$



Florida Department of Environmental Regulation

Northeast District • 3426 Bills Road • Jacksonville, Florida 32207 • 904-798-4200

Bob Martinez, Governor

Dale Twachtmann, Secretary

John Shearer, Assistant Secretary
Ernest Frey, Deputy Assistant Secretary

Permittee:

D-Graphics
3389 Powers Avenue
Jacksonville, Florida 32207

DRAFT

I.D. Number:

31-16-0238-04

Permit/Certification Number:

AO16-118645

Date of Issue:

Expiration Date:

September 30, 1991

County:

Duval

Latitude/Longitude:

30:15:55/81:37:18

UTM:

E-7440.092 N-3348.280

Project:

Rotogravure Press 5

This permit is issued under the provisions of Chapter 403, Florida Statutes, and Florida Administrative Code Rules 17-2 and 17-4. The above named permittee is hereby authorized to perform the work or operate the facility shown on the application and approved drawing(s), plans, and other documents attached hereto or on file with the department and made a part hereof and specifically described as follows:

For the operation of Rotogravure Press No. 5 for the printing of packaging labels. Volatile organic compound (VOC) emissions shall be controlled through the use of a Pillar Catalytic Incinerator (Model P-15000) and associated VOC capture and transport equipment.

Located at 3389 Powers Avenue, Jacksonville, Florida 32207

Emission point(s) shall be as follows:

Point

04

Source

Rotogravure Press No. 5

Supporting documents shall be as follows:

- (1) Certificate of Completion of Construction form dated December 31, 1985
- (2) Additional information received on April 16, 1986
- (3) Waiver of 90 day time limit dated June 6, 1986
- (4) VOC emission tests dated July 25 and 26, 1986
- (5) BESD letter dated April 10, 1986 requesting additional information
- (6) Permit AC16-089528
- (7) Consent Final Judgement dated February 28, 1985
- (8) Lowest achievable Emission Rate Determination dated February 18, 1985
- (9) Environmental Science and Engineering, Inc. (ESE) letter dated November 30, 1987 and December 31, 1987
- (10) BESD letter dated November 23, 1987
- (11) Department of Environmental Regulation memorandum dated April 15, 1990

Permittee:

D-Graphics

I.D. Number:

Permit/Certification Number:

Date of Issue:

Expiration Date:

31-16-0238-04

AO16-118645

September 30, 1991

GENERAL CONDITIONS:

1. The terms, conditions, requirements, limitations, and restrictions set forth herein are "Permit Conditions" and as such are binding upon the permittee and enforceable pursuant to Sections 403.141, 403.727, or 403.855 through 403.861, Florida Statutes. The permittee is placed on notice that the Department will review this permit periodically and may initiate enforcement action for any violation of these conditions.
2. This permit is valid only for the specific processes and operations applied for and indicated in the approved drawings or exhibits. Any unauthorized deviation from the approved drawings, exhibits, specifications, or conditions of this permit may constitute grounds for revocation and enforcement action by the Department.
3. As provided in Subsections 403.087(6) and 403.722(5), Florida Statutes, the issuance of this permit does not convey any vested rights or any exclusive privileges. Neither does it authorize any injury to public or private property or any invasion of personal rights, nor any infringement of federal, state, or local laws or regulations. This permit is not a waiver of or approval of any other department permit that may be required for other aspects of the total project which are not addressed in this permit.
4. This permit conveys no title to land or water, does not constitute State recognition or acknowledgment of title, and does not constitute authority for the use of submerged lands unless herein provided and the necessary title or leasehold interests have been obtained from the state. Only the Trustees of the Internal Improvement Trust Fund may express State opinion as to title.
5. This permit does not relieve the permittee from liability for harm or injury to human health or welfare, animal, or plant life, or property caused by the construction or operation of this permitted source, or from penalties therefore nor does it allow the permittee to cause pollution in contravention of Florida Statutes and Department rules, unless specifically authorized by an order from the Department.
5. The permittee shall properly operate and maintain the facility and systems of treatment and control (and related appurtenances) that are installed and used by the permittee to achieve compliance with the conditions of this permit, as required by Department rules. This provision includes the operation of backup or auxiliary facilities or similar systems when necessary to achieve compliance with the conditions of the permit and when required by department rules.
7. The permittee, by accepting this permit, specifically agrees to allow authorized Department personnel, upon presentation of credentials or other documents as may be required by law, and at reasonable times, access to the premises where the permitted activity is located or conducted to:
 - a. Have access to and copy any records that must be kept under conditions of the permit;
 - b. Inspect the facility, equipment, practices, or operations regulated or required under this permit; and
 - c. Sample or monitor any substances or parameters at any location reasonably necessary to assure compliance with this permit or Department rules.

Reasonable time may depend on the nature of the concern being investigated.

9. If, for any reason, the permittee does not comply with, or will be unable to comply with any condition or limitation specified in this permit, the permittee shall immediately provide the Department with the following information:
 - a. A description of and cause of non-compliance; and
 - b. The period of non-compliance, including dates and times; or, if not corrected, the anticipated time the non-compliance is expected to continue, and steps being taken to reduce, eliminate, and prevent recurrence of the non-compliance.

Permittee:

D-Graphics

I.D. Number:

Permit/Certification Number:

Date of Issue:

Expiration Date:

31-16-0238-04

AO16-118645

September 30, 1991

9. In accepting this permit, the permittee understands and agrees that all reports, notes, monitoring data and other information relating to the construction or operation of this permitted source, which are submitted to the Department, may be used by the Department as evidence in any enforcement case involving the permitted source arising under the Florida Statutes or Department rules, except where such use is proscribed by Sections 403.111 and 403.73, Florida Statutes. Such evidence shall only be used to the extent it is consistent with the Florida Rules of Civil Procedure and appropriate evidentiary rules.
10. The permittee agrees to comply with changes in Department rules and Florida Statutes after a reasonable time for compliance; provided, however, the permittee does not waive any other rights granted by Florida Statutes or Department rules.
11. This permit is transferable only upon Department approval in accordance with Rules 17-4.120 and 17-30.300, FAC, as applicable. The permittee shall be liable for any non-compliance of the permitted activity until the transfer is approved by the Department.
12. This permit, or a copy thereof, shall be kept at the work site of the permitted activity.
13. This permit also constitutes:
- Determination of Best Available Control Technology (BACT)
 - Determination of Prevention of Significant Deterioration (PSD)
 - Certification of Compliance with State Water Quality Standards (Section 401, PL 92-500)
 - Compliance with New Source Performance Standards
14. The permittee shall comply with the following:
- a. Upon request, the permittee shall furnish all records and plans required under Department rules. During enforcement actions, the retention period for all records will be extended automatically unless otherwise stipulated by the Department.
 - b. The permittee shall hold at the facility, or other location designated by this permit, records of all monitoring information (including all calibration and maintenance records and all original strip chart recordings for continuous monitoring instrumentation), required by this permit, copies of all reports required by this permit, and records of all data used to complete the application for this permit. These materials shall be retained at least three years from the date of the sample, measurement, report, or application unless otherwise specified by Department rule.
 - c. Records of monitoring information shall include:
 - the date, exact place, and time of sampling or measurements;
 - the person responsible for performing the sampling or measurements;
 - the date(s) analyses were performed;
 - the person responsible for performing the analyses;
 - the analytical techniques or methods used; and
 - the results of such analyses
15. When requested by the Department, the permittee shall within a reasonable time furnish any information required by law which is needed to determine compliance with the permit. If the permittee becomes aware that relevant facts were not submitted or were incorrect in the permit application or in any report to the Department, such facts or information shall be submitted or corrected promptly.

Permittee:

D-Graphics

I.D. Number:

Permit/Certification Number:

Date of Issue:

Expiration Date:

31-16-0238-04

AO16-118645

September 30, 1991

SPECIFIC CONDITIONS:

1. Permittee shall notify the Bio-Environmental Services Division (BESD) thirty (30) days prior to source testing.
2. Copies of the test report(s) shall be submitted to BESD within forty-five (45) days of completion of testing in accordance with Rule 17-2.700(7)(b), FAC, and Rule 2.501, JEPB.
3. Testing of emissions shall be accomplished at a minimum of 90% of the permitted capacity. If testing is performed at a rate less than 90% of the permitted capacity, operation shall be limited to a maximum of 110% of the tested capacity until such time as an acceptable test is performed at a minimum of 90% of the permitted capacity. When operation is restricted to a lower capacity because of testing at such a level, BESD, upon advanced notification, will allow operation at higher capacities if such operation is for demonstrating compliance at a higher capacity.
4. Any revision(s) to a permit (and application) shall be submitted and approved prior to implementing.
5. Control equipment shall be provided with a method of access that is safe and reasonably accessible.
6. Stack sampling facilities shall be required and shall comply with the requirements of Rule 17-2.700(4), FAC, and Rule 2.207, JEPB.
7. Permittee shall submit an annual operation report to BESD for this source on the form supplied for each calendar year on or before March 1 in accordance with Rule 17-4.140, FAC.
8. The following pollutant(s) shall be tested at intervals indicated from the date of June 1, 1986:

<u>Pt. No.</u>	<u>Pollutant</u>	<u>Interval</u>
04	Volatile Organic Compounds (VOC)	12 Months

9. The applicable emission limiting rules shall be as follows:

<u>Pt. No.</u>	<u>Pollutant</u>	<u>¹FAC</u>	<u>²JEPB</u>
04	VOC	17-2.510(4)(a)	2.210

10. The maximum allowable emissions shall be as follows:

<u>Pt. No.</u>	<u>Pollutant</u>	<u>lbs/hr</u>	<u>T/yr</u>
04	VOC	130.83	378.75

11. Operation shall be limited to 5790 hours per year (run time).
12. The VOC applied to the substrate shall be limited to a maximum of 545.11 pounds per hour.

Permittee:

D-Graphics

I.D. Number:

Permit/Certification Number:

Date of Issue:

Expiration Date:

31-16-0238-04

AO16-118645

September 30, 1991

13. The source is subject to the emission standards established through a determination of LAER by a Consent Judgement (dated February 28, 1985, Case No. 83-138-54, C A Division D), which requires 80% overall capture and transport efficiency of the VOC delivered to the substrate and 95% total destruction of all VOC delivered to the inlet of the catalytic incinerator.
14. Compliance testing shall be performed in accordance with the following test protocols. See Appendix A.
15. Rotogravure Press No. 5 shall be tested individually and collectively with any press(es) utilizing this control device.
16. The permittee shall apply for a renewal operation permit sixty (60) days prior to the expiration date of this permit in accordance with Rule 17-4.090, FAC. Failure to submit a renewal application sixty (60) days prior to the expiration date shall result in the assessment of a penalty in accordance with Section 360.701(a)19., Ordinance Code, City of Jacksonville.

City of Jacksonville
Department of Health, Welfare and
Bio-Environmental Services

State of Florida
Department of Environmental Regulation

James L. Manning, Jr., Deputy Director

Ernest E. Fry, P.E., Deputy Assistant Secretary

DRAFT

DRAFT

¹Florida Administrative Code

²Jacksonville Environmental Protection Board

APPENDIX A

- A. The capture efficiency of the VOC collection system and the destruction efficiency of the incinerator shall be determined by simultaneously measuring the amount of VOC introduced to the process, the amount of VOC captured as measured at the incinerator inlet, and the amount of VOC leaving the incinerator as measured at the incinerator outlet. All testing shall be done in accordance with U.S. EPA "Guidelines for Developing Capture Efficiency Protocols," March 13, 1990. Specific test procedures shall be as follows:

VOC introduced to the process	-	Procedure L
VOC captured (inlet)	-	Procedure G ₁
VOC emitted (outlet)	-	Procedure G ₁

VOC audit gases, as required pursuant to G₁, Section 5.4, will be provided by Bio-Environmental Services Division.

- B. If the permittee believes that a significant amount of the captured VOCs are oxidized in the ovens or in the exhaust recirculation system, the permittee may elect to conduct additional testing to determine the amount of captured VOCs being oxidized as follows:

Nomenclature

L = Liquid phase VOC input.

G = Gaseous phase captured VOC emissions measured by procedures G₁.

G_M = Captured VOC emissions adjusted to an as-methane basis.

AF = Adjustment factor, determined as the ratio of G(TOT)/G_M.

CO₂(NG) : CO₂ concentration at the incinerator inlet attributable to the natural gas burned as fuel in the drying ovens.

CO₂(AMB) : CO₂ concentration at the incinerator inlet attributable to the CO₂ concentration in ambient air.

CO₂(VOC) : CO₂ concentration at the incinerator inlet attributable to gaseous phase captured VOC emissions oxidized in the ovens prior to reaching the incinerator.

G(TOT) = Total captured VOC emissions at the incinerator inlet, determined as the sum of G_M and CO₂(VOC).

CO(TOT), CO₂(TOT) : Total CO or CO₂ measured at the incinerator inlet using EPA Method 25 analyses.

- (1) Using the procedures for single-point, integrated sampling from EPA reference method 3, obtain an integrated captured gas sample during each captured VOC pollutant determination. The sampling runs should be simultaneous with, and for the same total

length of time as, the captured VOC determination. These bags will be analyzed for CO₂(TOT), CO(TOT) by EPA reference method 25. This analysis is necessary to determine concentrations in the part per million range.

- (2) Following the sampling described above, bag standards of the solvents used during the testing will be prepared, based upon the solvent composition used during the test. Standards will be prepared according to the standards preparation procedure of EPA reference method 18 at a concentration level of 10,000 parts per million, to match the expected source concentration. Using the same FIA used in paragraph A above, the FIA will then be calibrated with methane standards, and the solvent bag standards will be analyzed. A relative response factor for solvent-to-methane basis conversion will thus be determined. Using this response factor, VOC concentrations determined at the incinerator inlet (G) will be adjusted to an as-methane basis - (G_M).
- (3) Meter the amount of natural gas (CH₄) burned in the dryer ovens during the period of the capture efficiency testing, paragraph A above. Based upon the volumetric flow rate at the incinerator inlet, calculate the concentration of carbon dioxide (CO₂) expected in the captured gas stream as a result of the oxidation of the methane in the natural gas fuel (CO₂NG).
- (4) Determine the CO₂ concentration in the ambient air (CO₂AMB) using sampling and analytical procedures required in paragraph A above. An air-cooled or water-cooled condenser to remove moisture is not required. Alternately, an ambient CO₂ concentration of 350 ppm may be assumed.
- (5) Calculate the concentration of captured VOCs oxidized prior to the incinerator (CO₂VOC) as follows: From the total CO and CO₂ concentrations at the incinerator inlet determined by paragraph 1, subtract the concentration of CO₂ resulting from combustion of natural gas fuel as determined by paragraph 3, and the ambient CO₂ concentration determined by paragraph 4. Any remainder is attributable to captured VOCs combusted in the ovens or exhaust recirculation system.

$$\text{Equation 1: } \text{CO}_2\text{VOC} = \text{CO}_{\text{TOT}} + \text{CO}_2\text{TOT} - \text{CO}_2\text{NG} - \text{CO}_2\text{AMB}$$

- (6) Determine the total captured VOC emissions at the incinerator inlet - G(TOT), by adding the captured VOC adjusted to an as-methane basis (G_M), and the CO₂ concentration at the incinerator attributable to captured VOC oxidized in the ovens CO₂(VOC).

$$\text{Equation 2: } G(\text{TOT}) = G_M + \text{CO}_2(\text{VOC})$$

- (7) Determine the VOC preincineration adjustment factor (AF), by dividing total captured VOCs G(TOT) by captured VOC as-methane G_M.

$$\text{Equation 3: } \text{AF} = \frac{G(\text{TOT})}{G_M}$$

- (8) Determine capture efficiency (CE) by multiplying captured gaseous phase VOC emissions (G) by the VOC preincineration adjustment factor AF, and divide the product by the liquid VOC input (L).

$$\text{Equation 4: } \text{CE} = \frac{G \times \text{AF}}{L}$$

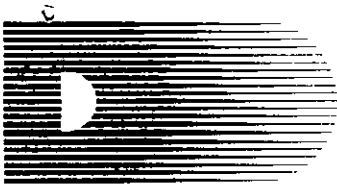

Demtrol Systems Division
Diversified Emission Control

Attachment D

651 North Avenue
Hartland, WI 53029
(414) 367-7548
FAX (414) 367-0831

August 2, 1994

D-Graphics Division of
Dinagraphics, Inc.
3389 Powers Avenue
Jacksonville, FL 32207
Attn: Mr. Doug Turner/Plant Manager

Dear Mr. Turner,

Per our phone conversation today, enclosed please find information regarding replacement components on oxidizer system.

1. Burner is Eclipse 560AH natural gas burner with integral combustion blower. Burner is rated at maximum 6.0 MMBTUH at 1,000,000 BTU/linear foot. Average anticipated requirement at approximately 2.75 MMBTUH. Minimum rating is at 150,000 BTUH.
2. The two (2) catalyst beds are designed as horizontal flatbeds and are each 7' long X 8' wide and capable of holding up to 10" of catalyst depth. They are sized to manage as a maximum based on maintaining 15,000 GHSV (80 cubic feet) with a maximum 20,000 SCFM.

If you would require further information, please do not hesitate to call on us.

Sincerely,
DEMOTROL SYSTEMS DIVISION of
Diversified Industrial Products, Inc.

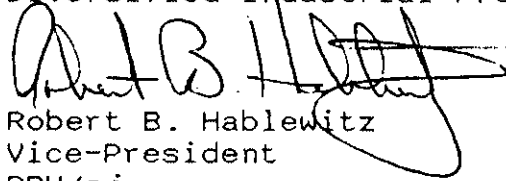
Robert B. Hablewitz
Vice-President
RBH/sj