

Check Sheet

Company Name: NATIONAL CHEMICAL CO
Permit Number: AC16-041475
PSD Number: _____
Permit Engineer: _____

Application:

- | | |
|--|--------------------------|
| <input checked="" type="checkbox"/> Initial Application | Cross References: |
| <input checked="" type="checkbox"/> Incompleteness Letters | <input type="checkbox"/> |
| <input checked="" type="checkbox"/> Responses | <input type="checkbox"/> |
| <input type="checkbox"/> Waiver of Department Action | <input type="checkbox"/> |
| <input type="checkbox"/> Department Response | |
| <input type="checkbox"/> Other | |

Intent:

- Intent to Issue
- Notice of Intent to Issue
- Technical Evaluation
- BACT or LAER Determination

Unsigned Permit

Correspondence with:

- EPA
- Park Services
- Other

Proof of Publication ~~OK~~ O.K.

- Petitions - (Related to extensions, hearings, etc.)
- Waiver of Department Action
- Other

Final

Determination:

- Final Determination
- Signed Permit
- BACT or LAER Determination
- Other

Post Permit Correspondence:

- Extensions/Amendments/Modifications
- Other

Final Determination

National Cement Company

Bulk Cement Terminal

Duval County

Construction Permit

Application Number:

AC 16-41475

Florida Department of Environmental Regulation

Bureau of Air Quality Management

Central Air Permitting

June 9, 1981

National Cement Company

Bulk Cement Terminal

The construction permit has been reviewed by the Department. Public notice of the Department's intent to issue was published in the Florida Times-Union on May 6, 1981. The preliminary determination and technical evaluation were available for public inspection at the Duval County's Bio-Environmental Services (BES), the DER's St. Johns River Subdistrict and Bureau of Air Quality Management.

The only comment(s) came from BES requesting that operational and maintenance plans be a part of the operating permit conditions per the requirements of Section 17-2.13(7). Therefore, the requirements will become part of the Construction Permit package under Specific Conditions No. 10. No other comments or input were received and there were no modifications made.

It is recommended that the construction permit be issued as drafted with the addition of Specific Condition No. 10.

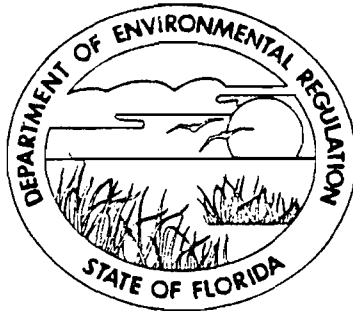

STATE OF FLORIDA
DEPARTMENT OF
ENVIRONMENTAL REGULATION

CONSTRUCTION
PERMIT

NO. AC 16-41475

NATIONAL CEMENT COMPANY

813 BOND STREET, JACKSONVILLE

DUVAL COUNTY, FLORIDA

DATE OF ISSUANCE

June 11, 1981

DATE OF EXPIRATION

NOVEMBER 11, 1981

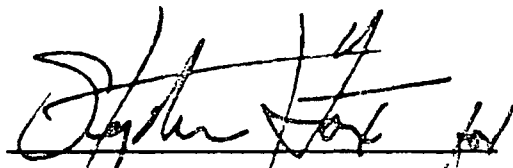
VICTORIA J. TSCHINKEL
SECRETARY



STATE OF FLORIDA

DEPARTMENT OF ENVIRONMENTAL REGULATION

APPLICANT: National Cement Company
110 Office Park Drive
Birmingham, Alabama 35223

PERMIT/CERTIFICATION
NO. AC 16-41475

COUNTY: Polk

PROJECT: Bulk Cement
Terminal

This permit is issued under the provisions of Chapter 403, Florida Statutes, and Chapter 17-2 and 17-4, Florida Administrative Code. The above named applicant, hereinafter called Permittee, is hereby authorized to perform the work or operate the facility shown on the approved drawing(s), plans, documents, and specifications attached hereto and made a part hereof and specifically described as follows:

For the construction of a bulk cement terminal to be located at 813 Bond Street in Jacksonville, Duval County, Florida. The UTM Coordinates of the proposed plant are 439.407 km East and 3,555.449 km North.

Construction shall be in accordance with the permit application and plans documents, and drawings except as otherwise noted on page 3 "Specific Conditions".

Attachments are as follows:

1. Application to Construct Air Pollution Sources, DER Form 17-1.122(16)
2. National Cement Company's letter of April 21, 1981, (Responses to Technical Discrepancies).

PERMIT NO.: AC 16-41475
APPLICANT: National Cement Company

GENERAL CONDITIONS:

1. The terms, conditions, requirements, limitations, and restrictions set forth herein are "Permit Conditions", and as such are binding upon the permittee and enforceable pursuant to the authority of Section 403.161(1), Florida Statutes. Permittee is hereby placed on notice that the department will review this permit periodically and may initiate court action for any violation of the "Permit Conditions" by the permittee, its agents, employees, servants or representatives.

2. This permit is valid only for the specific processes and operations indicated in the attached drawings or exhibits. Any unauthorized deviation from the approved drawings, exhibits, specifications, or conditions of this permit shall constitute grounds for revocation and enforcement action by the department.

3. If, for any reason, the permittee does not comply with or will be unable to comply with any condition or limitation specified in this permit, the permittee shall immediately notify and provide the department with the following information: (a) a description of and cause of non-compliance; and (b) the period of non-compliance, including exact dates and times; or, if not corrected, the anticipated time the non-compliance is expected to continue, and steps being taken to reduce, eliminate, and prevent recurrence of the non-compliance. The permittee shall be responsible for any and all damages which may result and may be subject to enforcement action by the department for penalties or revocation of this permit.

4. As provided in subsection 403.087(6), Florida Statutes, the issuance of this permit does not convey any vested rights or any exclusive privileges. Nor does it authorize any injury to public or private property or any invasion of personal rights, nor any infringement of federal, state or local laws or regulations.

5. This permit is required to be posted in a conspicuous location at the work site or source during the entire period of construction or operation.

6. In accepting this permit, the permittee understands and agrees that all records, notes, monitoring data and other information relating to the construction or operation of this permitted source, which are submitted to the department, may be used by the department as evidence in any enforcement case arising under the Florida Statutes or department rules, except where such use is proscribed by Section 403.111, F.S.

7. In the case of an operation permit, permittee agrees to comply with changes in department rules and Florida Statutes after a reasonable time for compliance, provided, however, the permittee does not waive any other rights granted by Florida Statutes or department rules.

8. This permit does not relieve the permittee from liability for harm or injury to human health or welfare, animal, plant, or aquatic life or property and penalties therefore caused by the construction or operation of this permitted source, nor does it allow the permittee to cause pollution in contravention of Florida Statutes and department rules, except where specifically authorized by an order from the department granting a variance or exception from department rules or state statutes.

9. This permit is not transferable. Upon sale or legal transfer of the property or facility covered by this permit, the permittee shall notify the department within thirty (30) days. The new owner must apply for a permit transfer within thirty (30) days. The permittee shall be liable for any non-compliance of the permitted source until the transferee applies for and receives a transfer of permit.

10. The permittee, by acceptance of this permit, specifically agrees to allow access to permitted source at reasonable times by department personnel presenting credentials for the purposes of inspection and testing to determine compliance with this permit and department rules.

11. This permit does not indicate a waiver of or approval of any other department permit that may be required for other aspects of the total project.

12. This permit conveys no title to land or water, nor constitutes state recognition or acknowledgement of title, and does not constitute authority for the reclamation of submerged lands unless herein provided and the necessary title or leasehold interests have been obtained from the state. Only the Trustees of the Internal Improvement Trust Fund may express state opinion as to title.

13. This permit also constitutes:

- Determination of Best Available Control Technology (BACT)
- Determination of Prevention of Significant Deterioration (PSD)
- Certification of Compliance with State Water Quality Standards (Section 401, PL 92-500)

PERMIT NO.: AC 16-41475
APPLICANT: National Cement Company

SPECIFIC CONDITIONS:

1. Maximum operation time will be 2600 hours per year.
2. Maximum utilization rate will be 50,000 tons per year and 38,462 pounds per hour of portland cement.
3. Maximum allowable particulate emissions will be 0.135 pounds per hour.
4. Because each particulate source will be controlled with a baghouse compliance testing will be limited to visible emissions as allowed in 17-2.23(2)(c)1. Visible emissions will be limited to 5% opacity. The Department will be notified thirty (30) days in advance of the compliance test.
5. Fugitive emissions from the facility shall be controlled by dust suppressants to insure that there will be no contributions to violations at ambient air quality standards.
6. Construction shall reasonably conform to the plans submitted in the application.
7. The applicant shall report any delays in construction and completion of this plant to the Bio-Environmental Services in Jacksonville.
8. The applicant will demonstrate compliance with the conditions of this construction permit and submit a complete application for an operating permit to the Bio-Environmental Services prior to 90 days before the expiration date of this permit. The applicant may continue to operate in compliance with all terms of this construction permit until its expiration or until issuance of an operating permit.
9. Upon obtaining an operating permit, the applicant will be required to submit periodic test reports on the actual operation and emissions of the facility.
10. An operation and maintenance plan for the particulate control devices, the collection systems and the processing system will be submitted for each source.

PERMIT NO.: AC 16-41475
APPLICANT: National Cement Company

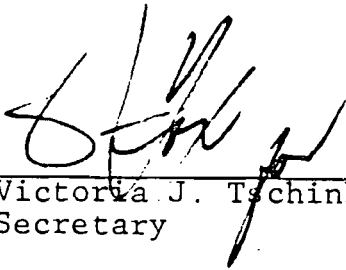

Victoria J. Tschinkel,
Secretary

Expiration Date: November 11, 1981

Issued this 11 day of June, 1981

____ Pages Attached.

STATE OF FLORIDA
DEPARTMENT OF ENVIRONMENTAL REGULATION

Signature

DEPARTMENT OF HEALTH, WELFARE
& BIO-ENVIRONMENTAL SERVICES
Bio-Environmental Services Division
Air and Water Pollution Control

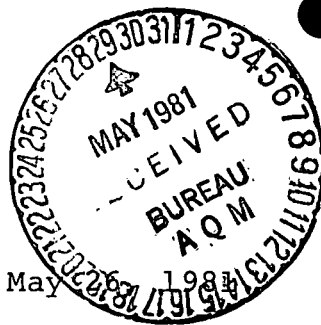

Mr. John Svec
Bureau of Air Quality Management
Florida Department of Environmental Regulation
2600 Blair Stone Road
Tallahassee, Florida 32301

RE: National Cement Company:
Application for permit to construct
a Bulk Cement terminal

Dear Mr. Svec:

Receipt of one copy of the subject application, and the Bureau's Technical Evaluation and Preliminary Determination is acknowledged.

This office is in agreement with the evaluation and proposed permit provisos. It is noted that the source is being permitted in accordance with the emission limiting standards of 17-2.13 (3)(k). It is suggested that the applicant submit an operation and maintenance plan per the requirement of Section 17-2.13 (7) now, rather than having to go through a permit revision in March of 1982.

Your consideration of this will be appreciated.

Very truly yours,

Wayne E. Tutt
Associate Engineer

WET/sg





WALTER K. DUNCAN
MANAGER - JACKSONVILLE

110 OFFICE PARK DRIVE
BIRMINGHAM, AL 35223
205/870-7680

NATIONAL CEMENT COMPANY



W. C. (BILL) SINGLETON
MANAGER-TECHNICAL SERVICES

110 OFFICE PARK DRIVE
BIRMINGHAM, AL 35223
205/870-7680

NATIONAL CEMENT COMPANY



1-800-633-6473

W. C. (BILL) SINGLETON
MANAGER-TECHNICAL SERVICES

110 OFFICE PARK DRIVE
BIRMINGHAM, AL 35223
205/870-7680

NATIONAL CEMENT COMPANY

LEGAL NOTICES

NOTICE OF RECEIPT OF
APPLICATION FOR PERMIT TO
CONSTRUCT/EXPAND AIR
POLLUTION SOURCE
TO WHOM IT MAY CONCERN

The Florida Department of Environmental Regulation has received an application from National Cement Company for a permit to construct/expand a Bulk Cement Terminal which is a source of air pollution located at 813 Bond Street, Jacksonville, Florida.

This application has been submitted by Mr. W. C. Singleton pursuant to Chapter 17-2, Florida Administrative Code regarding the control of emissions which may effect the maintenance of National Air Quality Standards.

The Department hereby gives notice of its intent to issue said permits. Copies of the aforementioned application and the technical analysis performed by the Department's staff are available for public inspection at the following location(s):

Florida Department of
Environmental Regulation,
3426 Bills Road
Jacksonville, Florida 32207

or
City of Jacksonville
Bio-Environmental Services
515 W. 6th Street
Jacksonville, Florida 32206

Persons wishing to comment on any aspect of this action are required to submit their comments in writing to the address above within thirty (30) days of publication of this notice or before June 4, 1981.

THE STATE OF FLORIDA
DEPARTMENT OF ENVIRONMENTAL REGULATION

The Florida Times-Union, Jacksonville, Wednesday, May 6, 1981

B-4

30 day ends 4/5/81

Public notice comments: 5/26/81 - B50

National Cement Co. Phone #: 354-7474
Fax.

Plant mgr. Mr. Duncan
rep. Mr. Bill Coche

Cement Co
RAB: 3/31/81 BAQM-Tally
Incomplete letter 4/16/81

BEST AVAILABLE COPY

Clocks
Begin
March 31, 81

Clocks
Incomplete:
4/16/81

Clocks:
Begin
4/22/81
complete

Const. DL
complete
5/5/81

Copies to BES - Ed Balducci 5/5/81
St. John's R.S.D. - John Ketteringham 5/5/81 - 5/4/81

STATE OF FLORIDA
DEPARTMENT OF ENVIRONMENTAL REGULATION

TWIN TOWERS OFFICE BUILDING
2600 BLAIR STONE ROAD
TALLAHASSEE, FLORIDA 32301



BOB GRAHAM
GOVERNOR
VICTORIA J. TSCHINKEL
SECRETARY

MEMORANDUM

TO: Mr. W. C. Singleton, National Cement Company
Mr. Walt Honour, Bio-Environmental Services
John Ketteringham, Air Engineer

for FROM: Steve Smallwood, Bureau of Air Quality Management
DATE: May 4, 1981 *CAA*

SUBJ: National Cement Company - Application for Permit to
Construct a Bulk Cement Terminal

Attached is one copy of the application, Technical Evaluation and Preliminary Determination, and proposed permit to construct a bulk cement terminal at 813 Bond Street in Jacksonville, Florida.

Please submit any comments which you wish to have considered concerning this action, in writing, to John Svec of the Bureau of Air Quality Management.

SS:caa

Public Notice

The Department intends to issue a permit to National Cement Company for the construction of a bulk portland cement terminal in Duval County at 813 Bond Street. The permit will include conditions to assure compliance with Chapter 17-2, Florida Administrative Code (F.A.C.).

Any person wishing to file comments on this proposed action may do so by submitting such comments in writing to:

Mr. John Svec
Bureau of Air Quality Management
Florida Department of Environmental
Regulation
2600 Blair Stone Road
Tallahassee, Florida 32301

Any comments received within thirty (30) days after publication of this notice will be considered and noted in the Department's final determination.

Any person whose substantial interest would be affected by the Department's intended action on this permit may request an administrative hearing by filing a petition as set forth in Section 28-5.15 F.A.C. within fourteen (14) days of the date of this notice with:

Ms. Mary Clark
Office of General Counsel
Department of Environmental Regulation
2600 Blair Stone Road
Tallahassee, Florida 32301

Technical Evaluation
and
Preliminary Determination

National Cement Company
Jacksonville, Florida

Application Number:

AC 16-41475

Florida Department of Environmental Regulation
Bureau of Air Quality Management
Central Air Permitting

I. PROJECT DESCRIPTION

A. Applicant

National Cement Company
110 Office Park Drive
Birmingham, Alabama 35223

B. Project and Location

The applicant proposes to construct a bulk cement terminal. The facility will have an average utilization rate of 38,462 pounds of portland cement per hour.

The plant location will be at 813 Bond Street, Jacksonville, Florida. UTM coordinates are 439.407 km East and 3,555.449 km North.

C. Process and Controls

The principal process consists of two twenty-five tons per hour (TPH) pneumatic railway unloaders that can either fill two two-hundred ton holding silos and/or one one-hundred seventy-five ton holding silo, with the latter serving as the only unit for loading trucks.

The cement transfer will be controlled by two baghouses, one for filling of the silos and the other for loading the trucks. The high efficiency baghouses are of the best demonstrated control technology for particulate removal. These controls will reduce the total emissions from the proposed sources to a level that is in compliance with New Source Performance Standards (NSPS) requirements (40 CFR 60, Subpart F) and State regulations.

II. RULE APPLICABILITY

The proposed project is subject to preconstruction review under the provisions of Chapter 403, Florida Statutes, and Chapter 17-2, Florida Administrative Code.

The proposed project is located in the Duval County particulate non-attainment area. Since potential emissions are greater than fifteen tons per year (TPY) and allowable emissions are less than fifty TPY, this is a "Tier I" source and is subject to the limited New Source Review (NSR) exemption at 17-2.17(3)(a)1.a.(ii) requiring permitting in accordance with 17-2.17(4).

Under 17-2.17(4), review should be conducted in accordance with New Source Performance Standards (NSPS) or any applicable emission limiting standard in 17-2, with precedence going to the more restrictive limit. NSPS has only limited applicability in that it is primarily concerned with kiln and clinker cooler emissions. The only applicable emission limit is 10% opacity

as "other". Therefore, this facility will be permitted in accordance with NSPS and 17-2.13(k), as required in 17-2.17(4). The requirements shall be no allowance of any visible emissions greater than five percent opacity and no emissions of particulate greater than 0.03 gr/dscf from each source.

III. SUMMARY OF EMISSIONS AND AIR QUALITY ANALYSIS

A. Emission Limitations

The regulated pollutant emissions from this facility are particulate and opacity in accordance with 17-2.13(k).

Emission Limiting Standard

Pollutant	(gr./dscf)	Plant Allowable Emissions (lb./hr)
Particulate	0.03	0.135
Visible Emissions	5% Opacity	

The permitted emissions are in compliance with all applicable requirements of Chapter 17-2 including the adopted New Source Performance Standard (NSPS) requirements of 40 CFR 60, Subpart F..

B. Air Quality Impacts

From the application technical review, it has been determined that the construction and operation of this facility will not have any impact on ambient air quality standards.

IV. CONCLUSIONS

The emission limits proposed by the applicant of 0.135 pounds per hour (#/hr) and 5% opacity have been determined to be acceptable and can be achieved at this facility.

The permitted emissions from the facility, with its maximum utilization rate of 50,000 tons per year (TPY) portland cement, will not cause or contribute to any violation of ambient air quality standards.

The General and Specific Conditions listed in the proposed permits (attached) will assure compliance with all applicable requirements of Chapter 17-2, F.A.C.



OUR NEW MAILING ADDRESS IS:
112 SOUTH BOND STREET
FERNANDINA BEACH, FLORIDA 32034

ENGINEERING SERVICES TO INDUSTRY

Robert H. Hart & Associates, Inc.
P. O. Box 142, Fernandina Beach, Florida 32034
(904) 261-3054

April 21, 1981

Mr. Bruce Mitchell
Department of Environmental Regulation
State of Florida
Twin Towers Office Building
2600 Blair Stone Road
Tallahassee, FL 32301



RE: National Cement Company
Air Pollution Permit
Application Addendum

Dear Mr. Mitchell:

Enclosed is an addendum to the Air Pollution Source Permit Application for the National Cement Company Bulk Cement Terminal, 813 Bond Street, Duval County, Jacksonville, Florida. Its purpose is to address the items of your letter of April 16, 1981. I believe I have addressed each item as I understand them. If, however, there is further clarification on this project that is necessary or may prove helpful, please don't hesitate to call. As you know, time is critical on this project and we want to be sure we don't cause you any delay in your permitting process.

Very truly yours,

ROBERT H. HART & ASSOCIATES, INC.

George J. McDonnell, P. E.

GMCD/skg
Enclosures

cc: Mr. W. C. Singleton - w/encl.

SECTION III: AIR POLLUTION SOURCES & CONTROL DEVICES (Other than Incinerators)

A. Raw Materials and Chemicals Used in your Process, if applicable:

Description	Contaminants		Utilization Rate - lbs/hr	Relate to Flow Diagram
	Type	% Wt		
Portland Cement	Particulate	100%	38462 Avg. (50,000 T/YR)	Sheet 3

B. Process Rate, if applicable: (See Section V, Item 1)

- Total Process Input Rate (lbs/hr): 38462 Avg. (50,000 T/YR)
- Product Weight (lbs/hr): 38462 Avg. (50,000 T/YR)

C. Airborne Contaminants Emitted:

Name of Contaminant	Emission ¹		Allowed Emission ² Rate per Ch. 17-2, F.A.C.	Allowable ³ Emission lbs/hr	Potential Emission ⁴		Relate to Flow Diagram
	Maximum lbs/hr	Actual T/yr			lbs/hr	T/yr	
Particulate	0.112	.041	17-2.13 (K)	0.139 0.155 (Avg.)	37.4	13.5	A, B

D. Control Devices: (See Section V, Item 4)

Name and Type (Model & Serial No.)	Contaminant	Efficiency	Range of Particles ⁵ Size Collected (in microns)	Basis for Efficiency (Sec. V, It ⁵)
ST 8-30 Baghouse	Particulate	99.7%	.1 Micron	AP 42 A-2
BV-125 Baghouse	Particulate	99.7%	.1 Micron	AP 42 A-2
Model 80 Unloader				
MC22 Spout				

¹See Section V, Item 2.

²Reference applicable emission standards and units (e.g., Section 17-2.05(6) Table II, E. (1), F.A.C. - 0.1 pounds per million BTU heat input)

³Calculated from operating rate and applicable standard

⁴Emission, if source operated without control (See Section V, Item 3)

⁵If Applicable

Caps File

STATE OF FLORIDA

DEPARTMENT OF ENVIRONMENTAL REGULATION

TWIN TOWERS OFFICE BUILDING
1000 BLAIR STONE ROAD
TALLAHASSEE, FLORIDA 32301

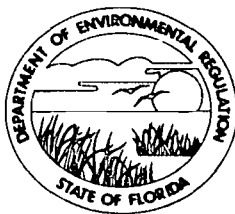

BOB GRAHAM
GOVERNOR
VICTORIA J. TSCHINKEL
SECRETARY

April 16, 1981

Mr. W.C. Singleton
National Cement Company
110 Office Park Drive
Birmingham, Alabama 35223

RE: Bulk Cement Terminal
813 Bond Street
Duval County
Jacksonville, Florida

Dear Mr. Singleton:

The Department has received your application to construct a bulk portland cement terminal with control equipment and have found it incomplete. The following items need to be addressed and/or clarified before your application can be processed.

- (1) In calculating the potential emissions, only the truck loading utilization rate of 38,462 pounds per hour (#PH) was used. The plant has the capability of operating the two railway unloaders and the truck loader at the same time. Therefore, an additional 50 tons per hour (TPH) or 100,000 #PH should have been included in the calculation, giving a total material handling rate of 138,462 #PH. The particulate potential emissions will have to be recalculated. (Calculations: #2, Potential Emissions).
- (2) In calculating actual emissions, the truck loading and rail unloading rates should have been used. The maximum and actual emissions will have to be recalculated. (Calculations: #3, Actual Emissions).
- (3) In calculating baghouse flowrates, the cement volume at 25 tons per hour (TPH) for the pneumatic conveyor was used. Since the application was for two(2) units, the cement volume of 50 TPH should have been used. This value will have to be recalculated. Also, recalculate the velocity at the bag. (Calculations: #4, Baghouse Flow Rate).

NATIONAL CEMENT COMPANY
 AIR POLLUTION PERMIT
 CALCULATIONS

1. Utilization Rate

$$\frac{50,000}{\text{yr. Tt}} \frac{2,000 \text{ lb}}{\text{day}} \frac{\text{day}}{10 \text{ hrs}} \frac{\text{wk}}{5 \text{ days}} \frac{\text{yr}}{52 \text{ wks}} = 38,462 \frac{\text{lb}}{\text{hr}}$$

2. Potential Emission AP-42 - 8.10.1

Concrete Batching - A similar process

Uncontrolled .2 lb/yd³ @ 735 lb cement/yd³

$$\text{Emission Factor} = \frac{.2 \text{ lb}}{735 \text{ lb}} \frac{2,000 \text{ lb}}{\text{ton}} = .54 \text{ lb/ton}$$

$$\text{Potential Emission} = \frac{138,462 \text{ lb}}{\text{hr}} \frac{\text{ton}}{2,000 \text{ lb}} \frac{.54 \text{ lb}}{\text{ton}}$$

$$= 37.4 \text{ lb/hr}$$

$$\text{Annual Potential Emission} = \frac{50,000 \text{ t}}{\text{yr}} \frac{.54 \text{ lb}}{\text{ton}} \frac{\text{ton}}{2,000 \text{ lb}}$$

$$= 13.5 \text{ ton/yr}$$

3. Actual Emissions

Baghouse Eff. = 99.7%

Maximum Flow Rate = 138,462 lb/hr

$$\text{Maximum Emission} = \frac{138,462 \text{ lb ton}}{2,000 \text{ lb hr}} \frac{.54 \text{ lb}}{\text{ton}} (1 - .997)$$

$$= 0.112 \text{ lb/hr}$$

Annual Flow Rate = 50,000 t/yr

$$\text{Actual Emissions} = \frac{50,000 \text{ ton}}{\text{yr}} \frac{.54 \text{ lb}}{\text{ton}} \frac{\text{ton}}{2,000 \text{ lb}} (1 - .997)$$

$$= .041 \text{ t/yr}$$



Midwest Metric Series MC-22 Enclosed Truck Loading Spout

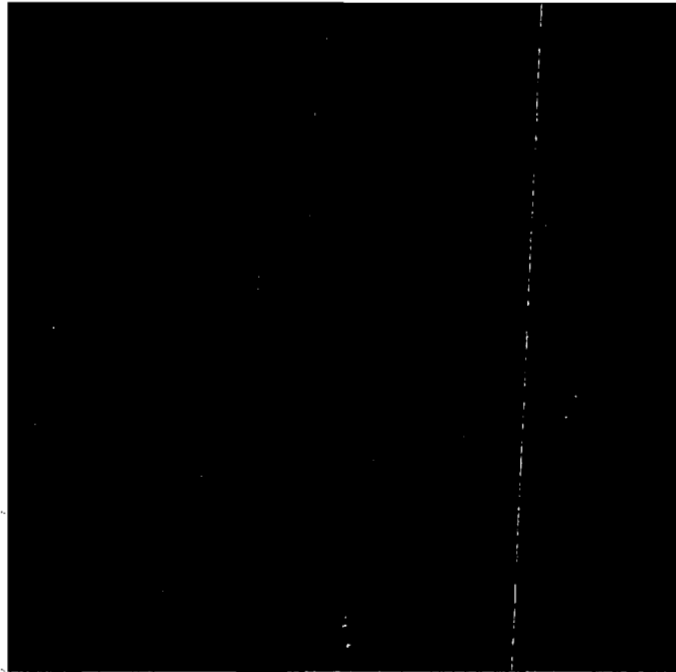

If your product is dry and dusty, the Midwest MC-22 can help you load it 'dust-free'.

Based on the innovative Venturi Scavenger system the MC-22 is capable of loading over 450 MTPH into enclosed trucks.

Simply by connecting the spout's dust outlet bonnet to a dust extractor or suppression system, normally fugitive dust particles can be controlled and recirculated into the product flow.

Quality built—field tested, the MC-22 can be your economical answer to costly and hazardous dust emissions.

Photo shown with some optional equipment.

General Specifications

Front View

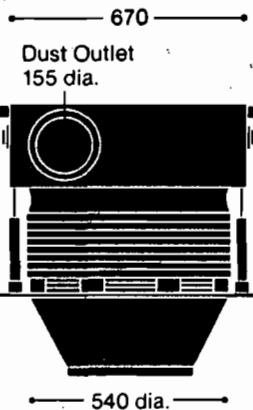

Retracted Height
750 mm.
Stock Travel Available
1200 mm*
Weight
125 kg. with maximum travel.
Maximum Capacity
540 STPH 486 MTPH.
Capacity based on a product weight of 960 kg/m³ fines.
Product Inlet
350 mm dia. flanged.
Motor
1/3HP/3PH/TEFC/IEC.
1750 RPM.
Drive
Heavy duty worm gear reducer
output speed 29RPM.
Ratio 60:1.
Lifting speed 13m/min.

Partially Extended

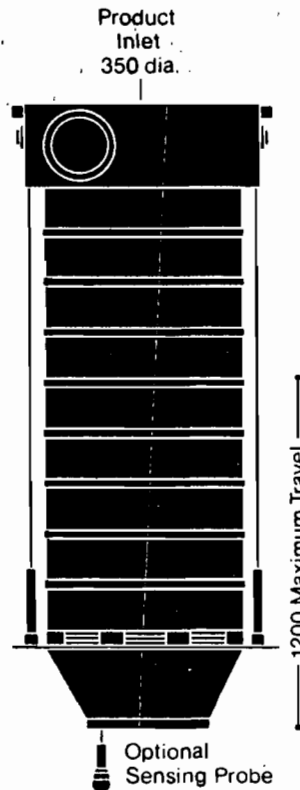

Side View

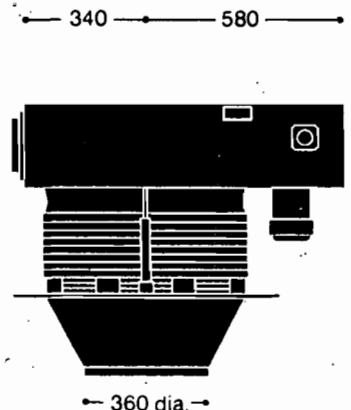

Limit Switch
For gear reducer protection, stops the unit in full 'up' or full 'down' position.
Voltages Available
230/460V 60 Hz, 575V 60 Hz, 380V 50 Hz, 415V 50 Hz.
Dust Outlet Connection
155 mm flanged.
Recommended Dust Extractor
22 to 28 CMM.
Venturi and Scavenger Construction
2.5 mm galvanized steel.
Flexible Outer Spout
Standard construction, includes aluminum rings, and Anti-Static Lines.

*NOTE: Effective 1 January 1980 Stock Travel available increased to 1500 mm.

Optional Construction

Venturi and/or Scavenger
Mild Steel, 4 mm Thick.
AR (Abrasive Resistant).

Type 304 Stainless Steel.
Type 316 Stainless Steel.
Type 3003 Aluminum.

Flexible Outer Spout
Heat Resistant Material.
Cold Weather Material.

Mr. Singleton
April 16, 1981
Page Two

- (4) In reference to #3, the air flow rate per ton from the rail unloaders will have to be recalculated. Also, the air flow rate to the truck will have to be recalculated since the baghouse flowrate at 670 CFM was used and the value of 970 CFM should have been used. (Calculations: #5, Allowable Emissions).

Please make any changes in the application where the new values are applicable and address these changes in an addendum to the original application. When the Department receives these requested changes, your application will be completely processed. If there are any questions, please contact Bruce Mitchell, Central Air Permitting Section, at (904) 488-1344.

Sincerely,



for Steve Smallwood
Bureau of Air Quality Management

SS:dav

cc: George McDonnell, P.E.

AC 16-41475



STATE OF FLORIDA
DEPARTMENT OF ENVIRONMENTAL REGULATION
APPLICATION TO OPERATE/CONSTRUCT
AIR POLLUTION SOURCES

SOURCE TYPE: Bulk Cement Terminal New¹ Existing¹
APPLICATION TYPE: Construction Operation Modification
COMPANY NAME: National Cement Company COUNTY: Duval

Identify the specific emission point source(s) addressed in this application (i.e. Lime Kiln No. 4 with Venturi Scrubber; Peeking Unit No. 2, Gas Fired) Bulk Cement Terminal

SOURCE LOCATION: Street 813 Bond Street City Jacksonville
UTM: East 439,407 North 3,555,449
Latitude 30° 19' 51" N Longitude 81° 37' 47" W

APPLICANT NAME AND TITLE: National Cement Company
APPLICANT ADDRESS: 110 Office Park Drive, Birmingham, Alabama 35223

SECTION I: STATEMENTS BY APPLICANT AND ENGINEER

A. APPLICANT

I am the undersigned owner or authorized representative* of National Cement Company

I certify that the statements made in this application for a Construction permit are true, correct and complete to the best of my knowledge and belief. Further, I agree to maintain and operate the pollution control source and pollution control facilities in such a manner as to comply with the provision of Chapter 403, Florida Statutes, and all the rules and regulations of the department and revisions thereof. I also understand that a permit, if granted by the department, will be non-transferable and I will promptly notify the department upon sale or legal transfer of the permitted establishment.

*Attach letter of authorization

Signed: [Signature]
W. C. Singleton, Manager, Technical Services
Name and Title (Please Type)
Date: 30 Mar 81 Telephone No. (205) 870-7680

B. PROFESSIONAL ENGINEER REGISTERED IN FLORIDA (where required by Chapter 471, F.S.)

This is to certify that the engineering features of this pollution control project have been designed/examined by me and found to be in conformity with modern engineering principles applicable to the treatment and disposal of pollutants characterized in the permit application. There is reasonable assurance, in my professional judgment, that the pollution control facilities, when properly maintained and operated, will discharge an effluent that complies with all applicable statutes of the State of Florida and the rules and regulations of the department. It is also agreed that the undersigned will furnish, if authorized by the owner, the applicant a set of instructions for the proper maintenance and operation of the pollution control facilities and, if applicable, pollution sources.

(Affix Seal)

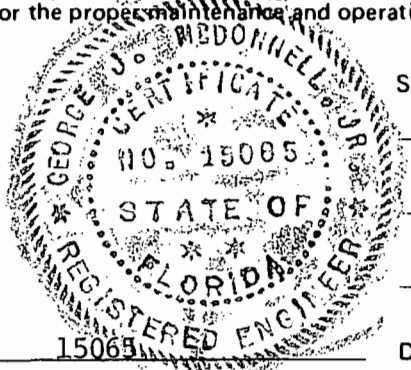

Signed: [Signature]
George J. McDonnell, P. E.
Name (Please Type)
Robert H. Hart & Associates, Inc.
Company Name (Please Type)
112 South Third Street, Fern. Bch., FL 3203
Mailing Address (Please Type)
Date: 30 MAR 81 Telephone No. (904) 355-8187

Florida Registration No. 15085

BEST AVAILABLE COPY

STATE OF FLORIDA
DEPARTMENT OF ENVIRONMENTAL REGULATION

Nº 33565

RECEIPT FOR APPLICATION FEES AND MISCELLANEOUS REVENUE

Received from William C. Singleton Date March 31, 1981

Address 2876 Spring Valley Rd. Birmingham, Ala 35223 Dollars \$ 20⁰⁰

Applicant Name & Address National Cement Co. - 110 Office Park Dr. Birmingham, Ala. 35223

Source of Revenue _____

Revenue Code 0101 Application Number AC 16-41475

By Tim Powell

SECTION II: GENERAL PROJECT INFORMATION

A. Describe the nature and extent of the project. Refer to pollution control equipment, and expected improvements in source performance as a result of installation. State whether the project will result in full compliance. Attach additional sheet if necessary.

This plant is to receive bulk portland cement by rail and load out by truck for local delivery. Estimated throughput is 50,000 tons/year. The cement transfer will be protected by two (2) baghouses to filter displaced air and conveying air. The project should result in full compliance.

B. Schedule of project covered in this application (Construction Permit Application Only)

Start of Construction April 1, 1981 Completion of Construction May 1, 1981

C. Costs of pollution control system(s): (Note: Show breakdown of estimated costs only for individual components/units of the project serving pollution control purposes. Information on actual costs shall be furnished with the application for operation permit.)

<u>Two (2) Baghouses @ \$3,000.00 each</u>	<u>=</u>	<u>\$ 6,000.00</u>
<u>Rail Unloader Sealing Device</u>		<u>1,500.00</u>
<u>Truck Loading Spout</u>		<u>4,000.00</u>
<u>TOTAL ESTIMATED COST OF POLLUTION DEVICES</u>		<u>\$11,500.00</u>

D. Indicate any previous DER permits, orders and notices associated with the emission point, including permit issuance and expiration dates.

None

E. Is this application associated with or part of a Development of Regional Impact (DRI) pursuant to Chapter 380, Florida Statutes, and Chapter 22F-2, Florida Administrative Code? Yes No

F. Normal equipment operating time: hrs/day 10 ; days/wk 5 ; wks/yr 52 ; if power plant, hrs/yr _____ ; if seasonal, describe: Not Seasonal

G. If this is a new source or major modification, answer the following questions. (Yes or No)

1. Is this source in a non-attainment area for a particular pollutant? Yes
 - a. If yes, has "offset" been applied? No
 - b. If yes, has "Lowest Achievable Emission Rate" been applied? No
 - c. If yes, list non-attainment pollutants.
Particulate
2. Does best available control technology (BACT) apply to this source? If yes, see Section VI. RACT
3. Does the State "Prevention of Significant Deterioration" (PSD) requirements apply to this source? If yes, see Sections VI and VII. No
4. Do "Standards of Performance for New Stationary Sources" (NSPS) apply to this source? No
5. Do "National Emission Standards for Hazardous Air Pollutants" (NESHAP) apply to this source? No

Attach all supportive information related to any answer of "Yes". Attach any justification for any answer of "No" that might be considered questionable.

SECTION III: AIR POLLUTION SOURCES & CONTROL DEVICES (Other than Incinerators)

A. Raw Materials and Chemicals Used in your Process, if applicable:

Description	Contaminants		Utilization Rate - lbs/hr	Relate to Flow Diagram
	Type	% Wt		
Portland Cement	Particulate	100%	38462	Sheet 3

B. Process Rate, if applicable: (See Section V, Item 1)

1. Total Process Input Rate (lbs/hr): 38462

2. Product Weight (lbs/hr): 38462

C. Airborne Contaminants Emitted:

Name of Contaminant	Emission ¹		Allowed Emission ² Rate per Ch. 17-2, F.A.C.	Allowable ³ Emission lbs/hr	Potential Emission ⁴		Relate to Flow Diagram
	Maximum lbs/hr	Actual T/yr			lbs/hr	T/yr	
Particulate	.081	.041	17-2.13(K)	0.135	10.4	13.5	A, B

D. Control Devices: (See Section V, Item 4)

Name and Type (Model & Serial No.)	Contaminant	Efficiency	Range of Particles ⁵ Size Collected (in microns)	Basis for Efficiency (Sec. V, It ⁵)
ST 8-30 Baghouse	Particulate	99.7%	.1 Micron	AP 42 A-2
BV-125 Baghouse	Particulate	99.7%	.1 Micron	AP 42 A-2
Model 80 Unloader				
MC22 Spout				

¹See Section V, Item 2.

²Reference applicable emission standards and units (e.g., Section 17-2.05(6) Table II, E. (1), F.A.C. - 0.1 pounds per million BTU heat input)

³Calculated from operating rate and applicable standard

⁴Emission, if source operated without control (See Section V, Item 3)

⁵If Applicable

E. Fuels

Type (Be Specific)	Consumption*		Maximum Heat Input (MMBTU/hr)
	avg/hr	max./hr	
None			

*Units Natural Gas, MMCF/hr; Fuel Oils, barrels/hr; Coal, lbs/hr

Fuel Analysis:

Percent Sulfur: _____ Percent Ash: _____
 Density: _____ lbs/gal Typical Percent Nitrogen: _____
 Heat Capacity: _____ BTU/lb _____ BTU/gal
 Other Fuel Contaminants (which may cause air pollution): _____

F. If applicable, indicate the percent of fuel used for space heating. Annual Average _____ Maximum _____

G. Indicate liquid or solid wastes generated and method of disposal.

H. Emission Stack Geometry and Flow Characteristics (Provide data for each stack):

Stack Height: A-67 Ft. B-30 ft. Stack Diameter: A-1.35 B-.42 ft.
 Gas Flow Rate: A-1349 B-670 ACFM Gas Exit Temperature: Ambient °F.
 Water Vapor Content: 0 % Velocity: A-20 B-73.3 FPS

SECTION IV: INCINERATOR INFORMATION

N/A

Type of Waste	Type O (Plastics)	Type I (Rubbish)	Type II (Refuse)	Type III (Garbage)	Type IV (Pathological)	Type V (Liq & Gas By-prod.)	Type VI (Solid By-prod.)
Lbs/hr Incinerated							

Description of Waste _____

Total Weight Incinerated (lbs/hr) _____ Design Capacity (lbs/hr) _____

Approximate Number of Hours of Operation per day _____ days/week _____

Manufacturer _____

Date Constructed _____ Model No. _____

	Volume (ft) ³	Heat Release (BTU/hr)	Fuel		Temperature (°F)
			Type	BTU/hr	
Primary Chamber					
Secondary Chamber					

Stack Height: _____ ft. Stack Diameter _____ Stack Temp. _____
 Gas Flow Rate: _____ ACFM _____ DSCFM* Velocity _____ FPS

*If 50 or more tons per day design capacity, submit the emissions rate in grains per standard cubic foot dry gas corrected to 50% excess air.

Type of pollution control device: Cyclone Wet Scrubber Afterburner: Other (specify) _____

Brief description of operating characteristics of control devices: _____

Ultimate disposal of any effluent other than that emitted from the stack (scrubber water, ash, etc.):

SECTION V: SUPPLEMENTAL REQUIREMENTS

Please provide the following supplements where required for this application.

1. Total process input rate and product weight – show derivation.
2. To a construction application, attach basis of emission estimate (e.g., design calculations, design drawings, pertinent manufacturer's test data, etc.) and attach proposed methods (e.g., FR Part 60 Methods 1, 2, 3, 4, 5) to show proof of compliance with applicable standards. To an operation application, attach test results or methods used to show proof of compliance. Information provided when applying for an operation permit from a construction permit shall be indicative of the time at which the test was made.
3. Attach basis of potential discharge (e.g., emission factor, that is, AP42 test).
4. With construction permit application, include design details for all air pollution control systems (e.g., for baghouse include cloth to air ratio; for scrubber include cross-section sketch, etc.).
5. With construction permit application, attach derivation of control device(s) efficiency. Include test or design data. Items 2, 3, and 5 should be consistent: actual emissions = potential (1-efficiency).
6. An 8½" x 11" flow diagram which will, without revealing trade secrets, identify the individual operations and/or processes. Indicate where raw materials enter, where solid and liquid waste exit, where gaseous emissions and/or airborne particles are evolved and where finished products are obtained.
7. An 8½" x 11" plot plan showing the location of the establishment, and points of airborne emissions, in relation to the surrounding area, residences and other permanent structures and roadways (Example: Copy of relevant portion of USGS topographic map).
8. An 8½" x 11" plot plan of facility showing the location of manufacturing processes and outlets for airborne emissions. Relate all flows to the flow diagram.

9. An application fee of \$20, unless exempted by Section 17-4.05(3), F.A.C. The check should be made payable to the Department of Environmental Regulation.
10. With an application for operation permit, attach a Certificate of Completion of Construction indicating that the source was constructed as shown in the construction permit.

SECTION VI: BEST AVAILABLE CONTROL TECHNOLOGY

- A. Are standards of performance for new stationary sources pursuant to 40 C.F.R. Part 60 applicable to the source?
 Yes No

Contaminant	Rate or Concentration

- B. Has EPA declared the best available control technology for this class of sources (If yes, attach copy) Yes No

Contaminant	Rate or Concentration

- C. What emission levels do you propose as best available control technology?

Contaminant	Rate or Concentration

- D. Describe the existing control and treatment technology (if any).

- | | |
|---------------------------|----------------------|
| 1. Control Device/System: | 4. Capital Costs: |
| 2. Operating Principles: | 6. Operating Costs: |
| 3. Efficiency: * | 8. Maintenance Cost: |
| 5. Useful Life: | |
| 7. Energy: | |
| 9. Emissions: | |

Contaminant	Rate or Concentration

*Explain method of determining D 3 above.

10. Stack Parameters

- a. Height: ft.
- b. Diameter: ft.
- c. Flow Rate: ACFM
- d. Temperature: °F
- e. Velocity: FPS

E. Describe the control and treatment technology available (As many types as applicable, use additional pages if necessary).

1.

- a. Control Device:
- b. Operating Principles:
- c. Efficiency*:
- d. Capital Cost:
- e. Useful Life:
- f. Operating Cost:
- g. Energy*:
- h. Maintenance Cost:
- i. Availability of construction materials and process chemicals:
- j. Applicability to manufacturing processes:
- k. Ability to construct with control device, install in available space, and operate within proposed levels:

2.

- a. Control Device:
- b. Operating Principles:
- c. Efficiency*:
- d. Capital Cost:
- e. Useful Life:
- f. Operating Cost:
- g. Energy**:
- h. Maintenance Costs:
- i. Availability of construction materials and process chemicals:
- j. Applicability to manufacturing processes:
- k. Ability to construct with control device, install in available space, and operate within proposed levels:

*Explain method of determining efficiency.

**Energy to be reported in units of electrical power – KWH design rate.

3.

- a. Control Device:
- b. Operating Principles:
- c. Efficiency*:
- d. Capital Cost:
- e. Life:
- f. Operating Cost:
- g. Energy:
- h. Maintenance Cost:

*Explain method of determining efficiency above.

- i. Availability of construction materials and process chemicals:
- j. Applicability to manufacturing processes:
- k. Ability to construct with control device, install in available space and operate within proposed levels:

4.

- a. Control Device
- b. Operating Principles:
- c. Efficiency*:
- d. Capital Cost:
- e. Life:
- f. Operating Cost:
- g. Energy:
- h. Maintenance Cost:
- i. Availability of construction materials and process chemicals:
- j. Applicability to manufacturing processes:
- k. Ability to construct with control device, install in available space, and operate within proposed levels:

F. Describe the control technology selected:

- 1. Control Device:
- 2. Efficiency*:
- 3. Capital Cost:
- 4. Life:
- 5. Operating Cost:
- 6. Energy:
- 7. Maintenance Cost:
- 8. Manufacturer:
- 9. Other locations where employed on similar processes:

a.

- (1) Company:
- (2) Mailing Address:
- (3) City:
- (4) State:
- (5) Environmental Manager:
- (6) Telephone No.:

*Explain method of determining efficiency above.

(7) Emissions*:

Contaminant	Rate or Concentration

(8) Process Rate*:

b.

- (1) Company:
- (2) Mailing Address:
- (3) City:
- (4) State:

*Applicant must provide this information when available. Should this information not be available, applicant must state the reason(s) why.

(5) Environmental Manager:

(6) Telephone No.:

(7) Emissions*:

Contaminant

Rate or Concentration

Contaminant	Rate or Concentration

(8) Process Rate*:

10. Reason for selection and description of systems:

*Applicant must provide this information when available. Should this information not be available, applicant must state the reason(s) why.



NATIONAL CEMENT COMPANY

110 OFFICE PARK DRIVE • BIRMINGHAM, ALABAMA 35223 • AREA CODE 205 • 870-7680

March 26, 1981

TO WHOM IT MAY CONCERN:

This letter provides corporate authorization for Mr. W. C. Singleton to act in behalf of NATIONAL CEMENT COMPANY in filing and signing applications to construct and operate air pollution sources in the State of Florida.



J. A. Sumner
Corporate Secretary
NATIONAL CEMENT COMPANY



115
 125
 3359
 2 190 000
 FEET
 3358
 3357
 3356
 20'
 17
 100
 115
 47.42 N. 56.50 W. 5.3
 47.42 N. 56.50 W. 5.3
 4644 1 SE
 (ARLINGTON)

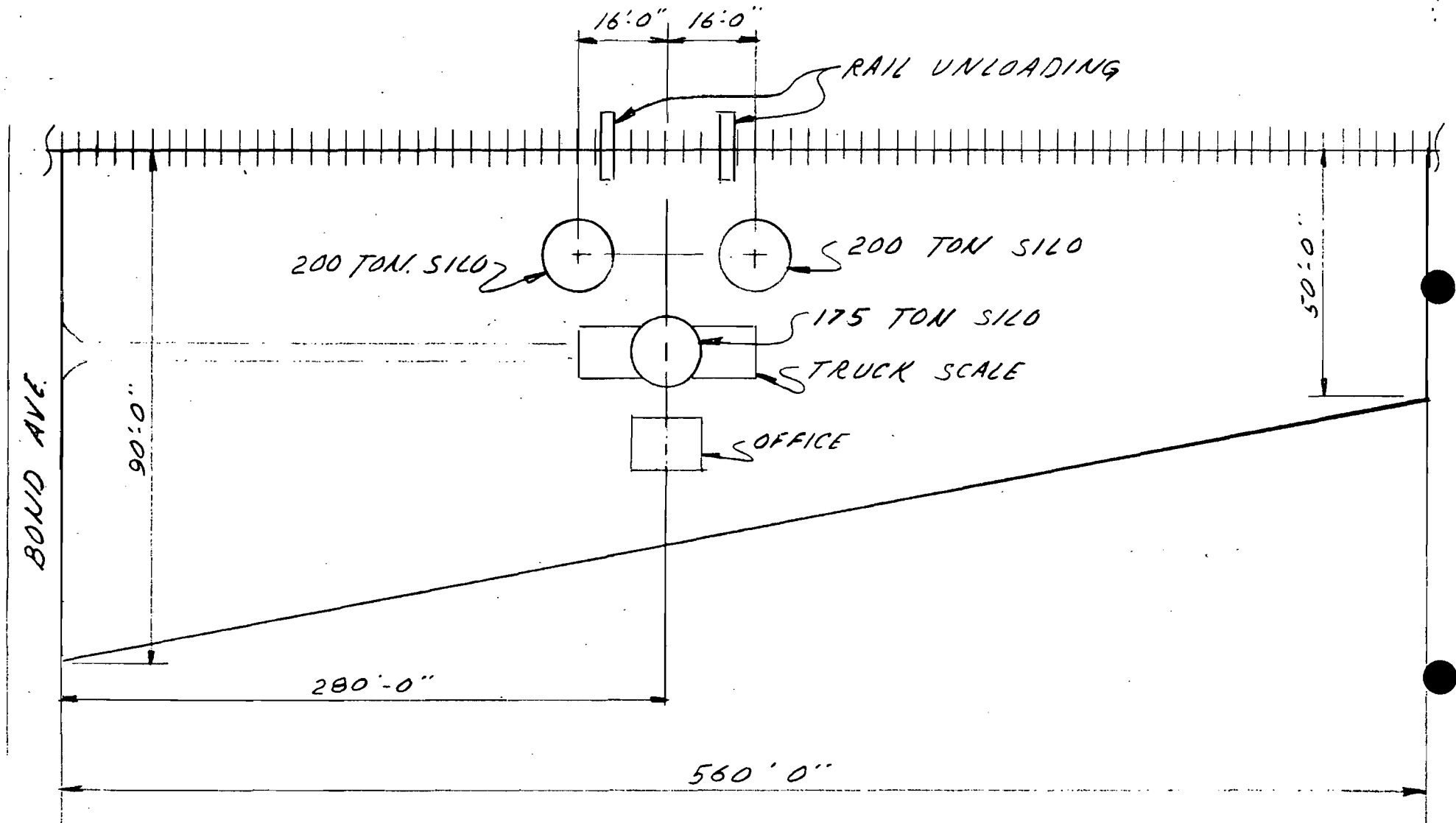

NATIONAL CEMENT Co.
 PLOT PLAN
 JACKSONVILLE, FLA.

NATIONAL CEMENT COMPANY
AIR POLLUTION PERMIT
CALCULATIONS

1. Utilization Rate

$$\frac{50,000}{\text{yr. Tt}} \frac{2,000 \text{ lb}}{\text{day}} \frac{\text{day}}{10 \text{ hrs}} \frac{\text{wk}}{5 \text{ days}} \frac{\text{yr}}{52 \text{ wks}} = 38,462 \frac{\text{lb}}{\text{hr}} \checkmark$$

2. Potential Emission AP-42 - 8.10.1

Concrete Batching - A similar process

Uncontrolled .2 lb/yd³ @ 735 lb cement/yd³

$$\text{Emission Factor} = \frac{.2 \text{ lb}}{735 \text{ lb}} \frac{2,000 \text{ lb}}{\text{ton}} = .54 \text{ lb/ton}$$

$$\text{Potential Emission} = \frac{138,462}{38,462 \text{ lb/hr}} \frac{\text{ton}}{2,000 \text{ lb}} \frac{.54 \text{ lb}}{\text{ton}}$$

$$= \frac{10.47}{37.66} \frac{\text{lb/hr}}{50,000 \text{ t}} \frac{.54 \text{ lb}}{\text{ton}} \frac{\text{ton}}{2,000 \text{ lb}}$$

$$= 13.61 \text{ ton/yr} \checkmark$$

(48.96 not as important as hourly)

3. Actual Emissions

$$\text{Baghouse Eff.} = 99.7\%$$

$$\text{Maximum Flow Rate} = \frac{138,462}{100,000} \text{ lb/hr}$$

$$\text{Maximum Emission} = \frac{138,462}{2,000 \text{ lb hr}} \frac{.54 \text{ lb}}{\text{ton}} (1 - .997)$$

$$= 0.081 \text{ lb/hr}$$

$$\text{Annual Flow Rate} = \frac{0.113}{50,000} \text{ t/yr}$$

$$\text{Actual Emissions} = \frac{50,000 \text{ ton}}{\text{yr}} \frac{.54 \text{ lb}}{\text{ton}} \frac{\text{ton}}{2,000 \text{ lb}} (1 - .997)$$

$$= .041 \text{ t/yr} \checkmark$$

4. Baghouse Flow Rates

Esstee Baghouse - 400 ft²

desired cement

Pneumatic Conveyor Flow Rate 670 CFM x 2 = 1340 CFM @ 27.2 ft³/ct, @ 94 lb/ct

Cement Volume $\frac{25 \text{ tons}}{\text{hr}} \times \frac{2,000 \text{ lb}}{\text{ton}} \times \frac{1 \text{ ft}^3}{94 \text{ lb}} \times \frac{60 \text{ min}}{\text{hr}} = 9 \text{ CFM}$ @ 27.2, 18.0

1349 CFM 1403, 1358

Velocity at Bag = $\frac{1349 \text{ ft}^3}{400 \text{ ft}^2 \text{ min}} = 3.37 \text{ fpm}$ @ 94 lb/ct @ 1358 CFM
3.4 fpm

Free Flow Baghouse - 125 ft²

Blower Flow Rate = 670 CFM

Cement Volume $\frac{540 \text{ tons}}{\text{hr}} \times \frac{2,000 \text{ lb}}{\text{ton}} \times \frac{1 \text{ ft}^3}{60 \text{ lb}} \times \frac{60 \text{ min}}{\text{hr}} = 300 \text{ CFM}$

= 970 CFM

Velocity at Bag = $\frac{970}{125} = 7.76 \text{ ft/min}$ @ 940 CFM
7.92 fpm

5. Allowable Emission 17.2.13 (k)

Allowable Rate - 0.03 gr/dscf

Find Air Flow Rate Per Ton

From Rail $\frac{1349 \text{ ft}^3}{\text{min}} \times \frac{60 \text{ min}}{\text{hr}} \times \frac{1 \text{ ton}}{50 \text{ ton}} = 1619 \frac{\text{ft}^3}{\text{ton}}$ @ 1300 CFM
1630

To Truck $\frac{970 \text{ ft}^3}{\text{min}} \times \frac{60 \text{ min}}{\text{hr}} \times \frac{1 \text{ ton}}{300 \text{ ft}^3 \text{ (cem)}} \times \frac{2,000 \text{ lb}}{94 \text{ lb}} = 48 \frac{\text{ft}^3}{\text{ton}}$ 69

1667 $\frac{\text{ft}^3}{\text{ton}}$

Allowable Rate/ton = $\frac{1667 \text{ ft}^3}{\text{ton}} \times \frac{0.03 \text{ gr}}{\text{dscf}} \times \frac{1 \text{ lb}}{7,000 \text{ gr}} = .007 \text{ lb/ton}$ ✓

Allowable Emission = $\frac{.007 \text{ lb}}{\text{ton}} \times \frac{38464 \text{ lb}}{\text{hr}} \times \frac{1 \text{ ton}}{2,000 \text{ lb}} = .135 \text{ lb/hr}$ ✓

NATIONAL CEMENT COMPANY
AIR POLLUTION PERMIT
CALCULATIONS

1. Utilization Rate

$$\frac{50,000}{\text{yr. Tt}} \frac{2,000 \text{ lb}}{\text{day}} \frac{\text{day}}{10 \text{ hrs}} \frac{\text{wk}}{5 \text{ days}} \frac{\text{yr}}{52 \text{ wks}} = 38,462 \frac{\text{lb}}{\text{hr}}$$

2. Potential Emission AP-42 - 8.10.1

Concrete Batching - A similar process

Uncontrolled .2 lb/yd³ @ 735 lb cement/yd³

$$\text{Emission Factor} = \frac{.2 \text{ lb}}{735 \text{ lb}} \frac{2,000 \text{ lb}}{\text{ton}} = .54 \text{ lb/ton}$$

$$\text{Potential Emission} = \frac{38,462 \text{ lb}}{\text{hr}} \frac{\text{ton}}{2,000 \text{ lb}} \frac{.54 \text{ lb}}{\text{ton}}$$

$$= 10.4 \text{ lb/hr}$$

$$\frac{50,000 \text{ t}}{\text{yr}} \frac{.54 \text{ lb}}{\text{ton}} \frac{\text{ton}}{2,000 \text{ lb}}$$

$$= 13.5 \text{ ton/yr}$$

3. Actual Emissions

Baghouse Eff. = 99.7%

Maximum Flow Rate = 100,000 lb/hr

$$\text{Maximum Emission} = \frac{100,000 \text{ lb ton}}{2,000 \text{ lb hr}} \frac{.54 \text{ lb}}{\text{ton}} (1 - .997)$$

$$= 0.081 \text{ lb/hr}$$

Annual Flow Rate = 50,000 t/yr

$$\text{Actual Emissions} = \frac{50,000 \text{ ton}}{\text{yr}} \frac{.54 \text{ lb}}{\text{ton}} \frac{\text{ton}}{2,000 \text{ lb}} (1 - .997)$$

$$= .041 \text{ t/yr}$$

4. Baghouse Flow Rates

Esstee Baghouse - 400 ft²

Pneumatic Conveyor Flow Rate 670 CFM x 2 = 1340 CFM

Cement Volume $\frac{25 \text{ tons}}{\text{hr}} \frac{2,000 \text{ lb}}{\text{ton}} \frac{\text{ft}^3}{94 \text{ lb}} \frac{\text{hr}}{60 \text{ min}} = 9 \text{ CFM}$
1349 CFM

Velocity at Bag = $\frac{1349 \text{ ft}^3}{400 \text{ ft}^2 \text{ min}} = 3.37 \text{ fpm}$

Free Flow Baghouse - 125 ft²

Blower Flow Rate 670 CFM

Cement Volume $\frac{540 \text{ tons}}{\text{hr}} \frac{\text{ft}^3}{60 \text{ lb}} \frac{2000 \text{ lb}}{\text{ton}} \frac{\text{hr}}{60 \text{ min}} = 300 \text{ CFM}$
= 970 CFM

Velocity at Bag = $\frac{970}{125} = 7.76 \text{ ft/min}$

5. Allowable Emission 17.2.13 (k)

Allowable Rate - 0.03 gr/dscf

Find Air Flow Rate Per Ton

From Rail $\frac{1349 \text{ ft}^3}{\text{min}} \frac{60 \text{ min}}{\text{hr}} \frac{\text{hr}}{50 \text{ ton}} = 1619 \frac{\text{ft}^3}{\text{ton}}$
 To Truck $\frac{670 \text{ ft}^3}{\text{min}} \frac{\text{min}}{300 \text{ ft}^3 \text{ (cem)}} \frac{\text{ft}^3}{94 \text{ lb}} \frac{2,000 \text{ lb}}{\text{ton}} = 48 \frac{\text{ft}^3}{\text{ton}}$
1667 $\frac{\text{ft}^3}{\text{ton}}$

Allowable Rate/ton = $\frac{1667 \text{ ft}^3}{\text{ton}} \frac{0.03 \text{ gr}}{\text{dscf}} \frac{\text{lb}}{7,000 \text{ gr}} = .007 \text{ lb/ton}$

Allowable Emission = $\frac{.007 \text{ lb}}{\text{ton}} \frac{38464 \text{ lb}}{\text{hr}} \frac{\text{ton}}{2,000 \text{ lb}} = .135 \text{ lb/hr}$

The ESSTEE Bin Vent also features items of standard equipment such as: 6" DIA. FELTED bags; precision-cast aluminum alloy venturis; hinged top-access door; weather-tight control system; heavy-duty bag cages; durable construction.

Some other optional features of the ESSTEE Bin Vents are: side-mounted fan for positive air displacement;

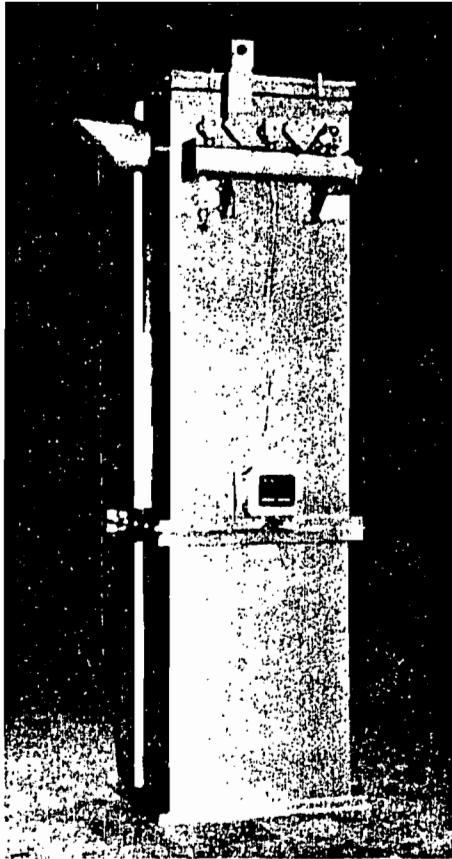

matching flanged section for mounting in silo roof; hopper section with counter-weighted tipping valve for independent bin mounting.

Some Applications Of The ESSTEE Bin Vent

- Filler-Dust Silos
- Fly-Ash Silos
- Plastic Sanding
- Wood Sanding
- In-Plant Grinding Systems
- Fertilizer Production
- Grain Storage
- Pneumatic Transport
- Foundry Shakeout
- Cement Handling



BIN VENTS

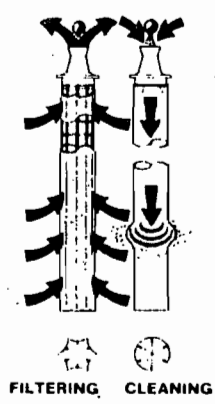
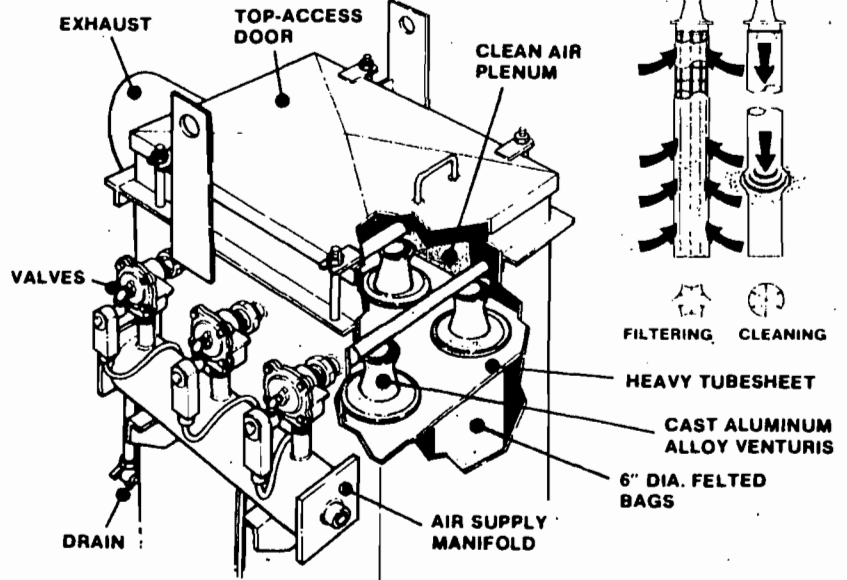

SPECIFICATIONS

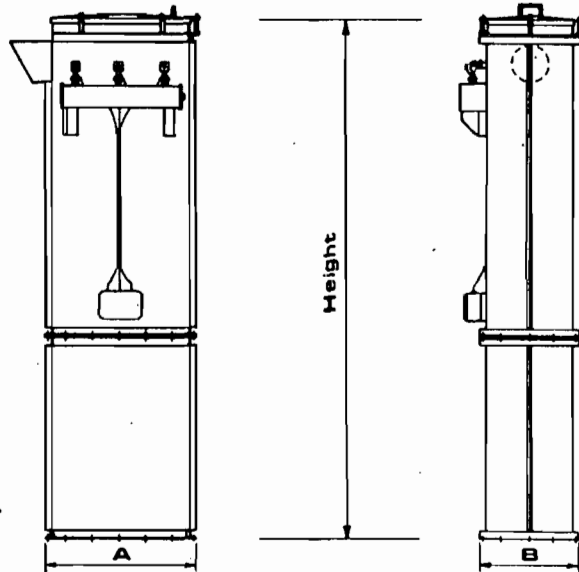

ST-8-6	75.0	9'-10"	2'-6"	20"
ST-9-6	84.3	10'-10"	2'-6"	20"
ST-10-6	93.6	11'-10"	2'-6"	20"

ST-8-12	150.0	9'-10"	3'-4"	2'-6"
ST-9-12	168.6	10'-10"	3'-4"	2'-6"
ST-10-12	187.2	11'-10"	3'-4"	2'-6"

STB-30-400² 9'-10" x 4'-2" x 5'-8"

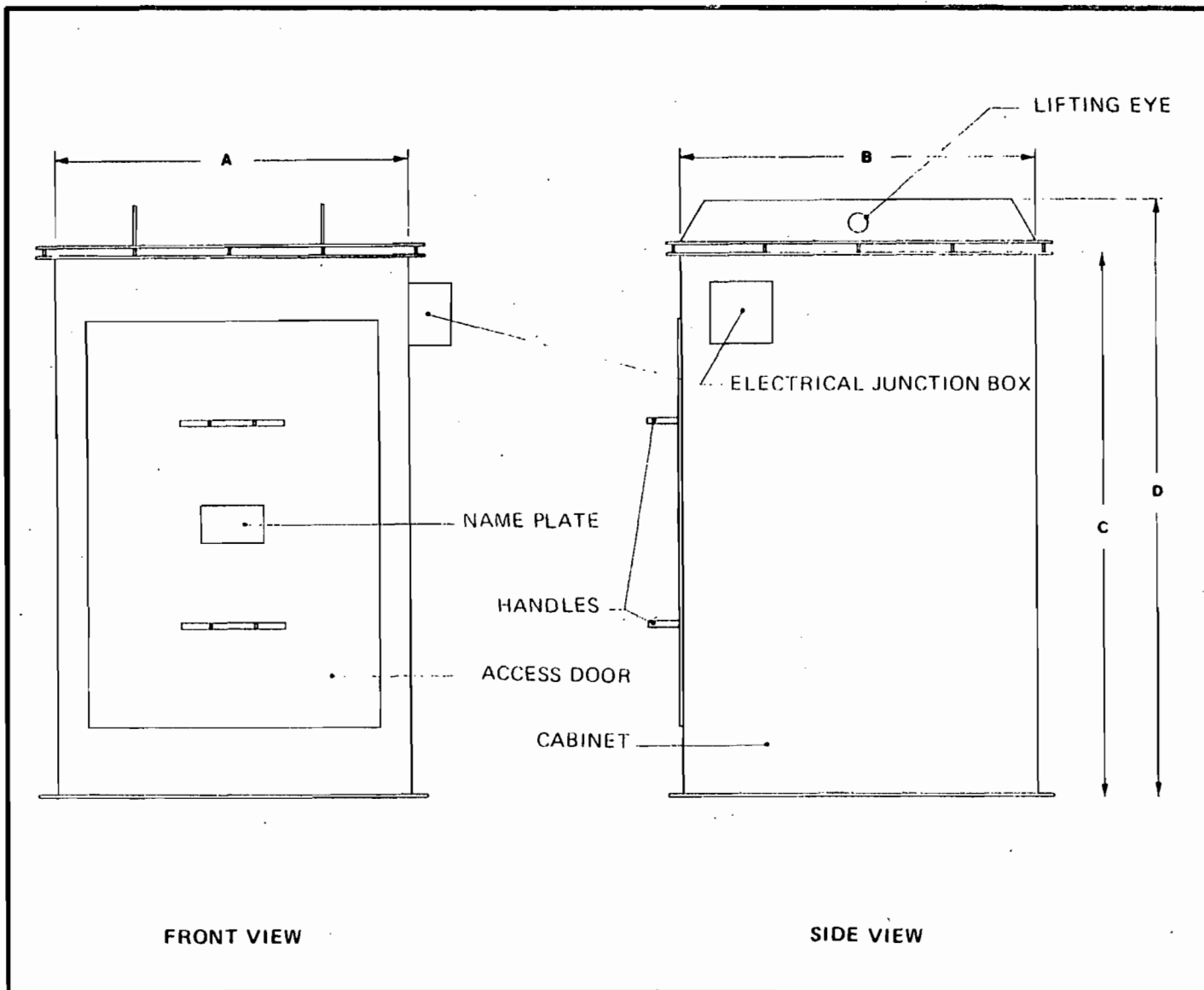

SPECIFICATIONS

MODEL	A	B	C	D	SQ. FT. CLOTH AREA
BV-125	34	34	54	59½	125
BV-200	34	34	81½	87	200
BV-300	45	39½	81½	87	300
BV-400	50½	45	81½	87	400
BV-500	56	50½	81½	87	500

The FREE FLOW Bag Vent, Model BV, prevents dust laden air from escaping storage bins during venting operations. The bag vents are equipped with a simple mechanical shaking mechanism. The horizontal shaking action very efficiently cleans the filter bags. The fabric filter bags are designed to handle a large volume of air with outstanding dust filtering characteristics. Units can be used in multiples to achieve required cloth area. Automatic controls are available for the bag vents as an optional accessory. These controls feature an adjustable timer for the shaking mechanism. In applications where negative pressure is required inside the storage bin, FREE FLOW offers various sizes of exhaust blowers as an accessory.

MIMCO, INC.

MATERIALS IN MOTION

282 Sand Bank Road, Cheshire, Connecticut 06410 Phone: 203 • 272-2257

HOPPER CAR UNLOADING EQUIPMENT

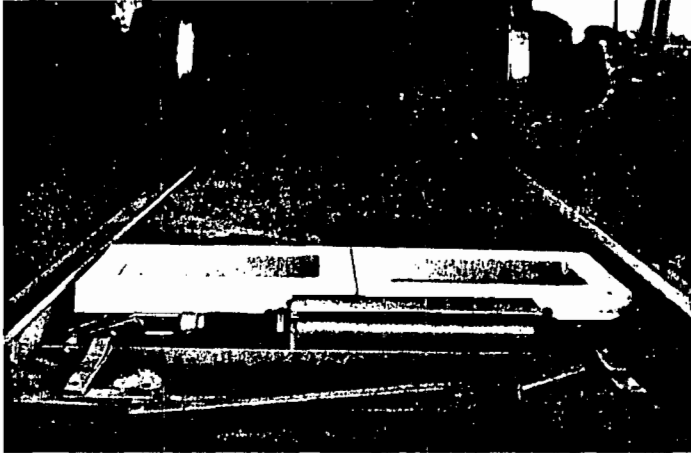

The MIMCO Unloader is today's faster, safer, most modern pneumatic connector to under-track conveyors. Easy to install, easy to operate, the Unloader does away with the unsafe, laborious and outdated manual hook-up method. It makes a secure connection in seconds.

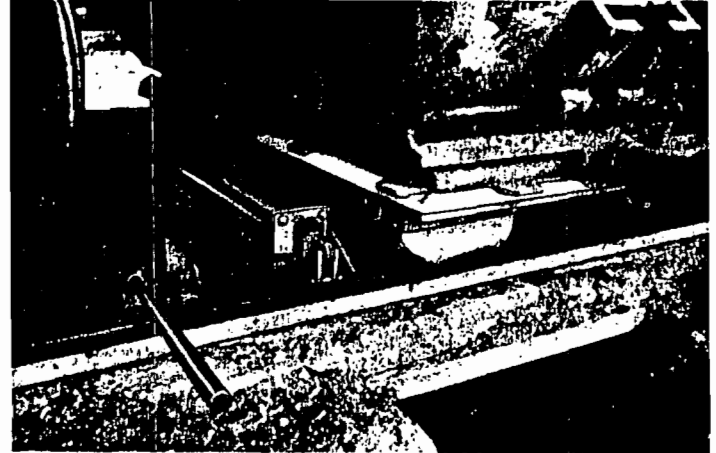

Overall production is increased with reduced labor costs. From hopper outlet to conveyor, materials flow is protected from contaminating moisture and dirt. Spillage and material loss is eliminated. Wind blown air pollution is minimized.

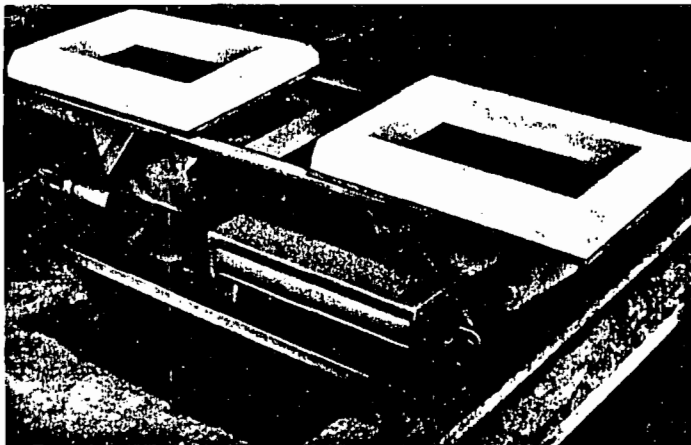

The Unloader is built for heavy duty service. Streamlined, simple in design and constructed of welded steel. Complete unit weighs only 200 lbs. Easy to handle for under-track clean up. Once conveyor pit has been prepared, the Unloader can be installed and operating in less than 30 minutes.

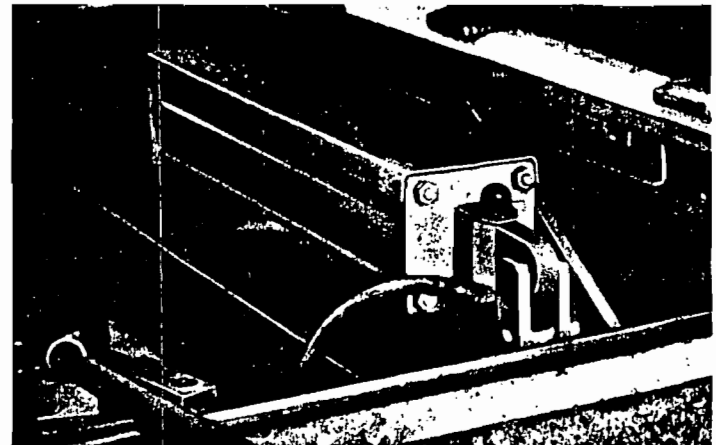

Positive hydraulic lock holds lift platform up to maintain connection even under heavy surge or air supply failure. Lock is integral with lift cylinder which is hydraulically damped internally. Damping controls lift action to facilitate quicker, easier height adjustment. Steel shield protects the cylinder.

Additional Unloader Advantages

- "Air Only" design allows simple hook-up, easy operation of single lift control.
- Unique leveling assembly assures smooth, even, rise of lift platform. No pulleys, cables or adjustment bars.
- Full flow funnels spread smoothly, simultaneously. To remove, simply lift funnels away from lift platform.
- Uniform, secure hopper door connection made by high density foam seals.
- Tough, rubberized nylon connector boots to fit **your** unloading installation.

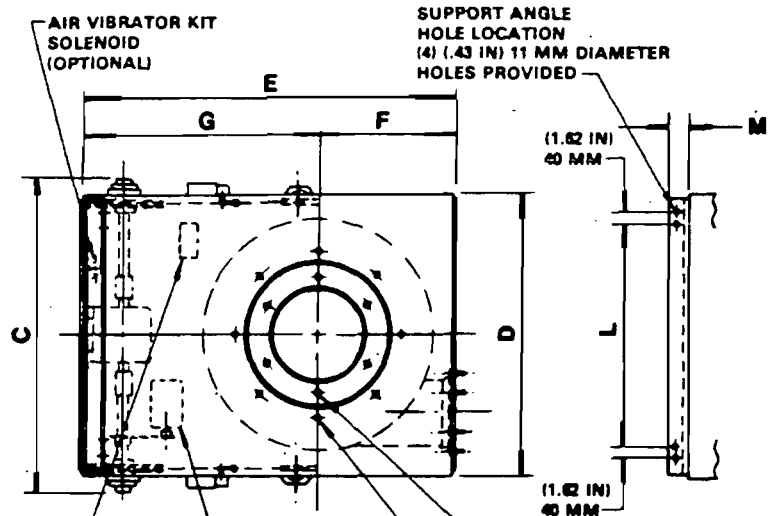

NOTES:

SPOUT DRIVE MOTORS ARE TOTALLY ENCLOSED, FAN COOLED.

PAN, VENTURI, OUTER AND INNER SCAVENGER CONSTRUCTION: TYPE 2 11 GAUGE (.125 IN.) 3 MM CARBON STEEL.

FLEXIBLE OUTER SPOUT CONSTRUCTION: VINYL COATED POLYESTER WITH ALUMINUM INNER AND OUTER RINGS AND ANTI-STATIC LINES.

MB15 AND MC22 ARE SHIPPED FACTORY ASSEMBLED.

SPECIFICATIONS AND/OR DIMENSIONAL DATA SUBJECT TO CHANGE WITHOUT NOTICE. CONSULT FACTORY FOR CERTIFIED DRAWING.

SPECIFICATIONS	MB15 SERIES		MC22 SERIES		
	4	1200	5	1800	
MAXIMUM TRAVEL FT/MM	4	1200	5	1800	
RETRACTED HEIGHT IN/MM	24	600	30	750	
NOMINAL PRODUCT					
INLET DIAMETER IN/MM	8	200	14	350	
APPROXIMATE LOADING CAPACITY AT 80 PCF 800 KG/M ³	240	215	640	485	
	TPH	MTPH	TPH	MTPH	
AVERAGE AIR WITH-DRAWAL REQUIREMENTS	480	13	1000	28	
	CFM	M ³ /M	CFM	M ³ /M	
SPOUT DRIVE	HP / KW	.5	.37	.5	.37
	LIFTING SPEED AT 80 HZ	FT/M/IN	MM/MIN	FT/M/IN	MM/MIN
	LIFTING SPEED AT 80 HZ	18	5.6	20	6.2
	GEAR REDUCER RATIO	78:1		78:1	
NET WEIGHT LBS/KG	180	82	320	145	

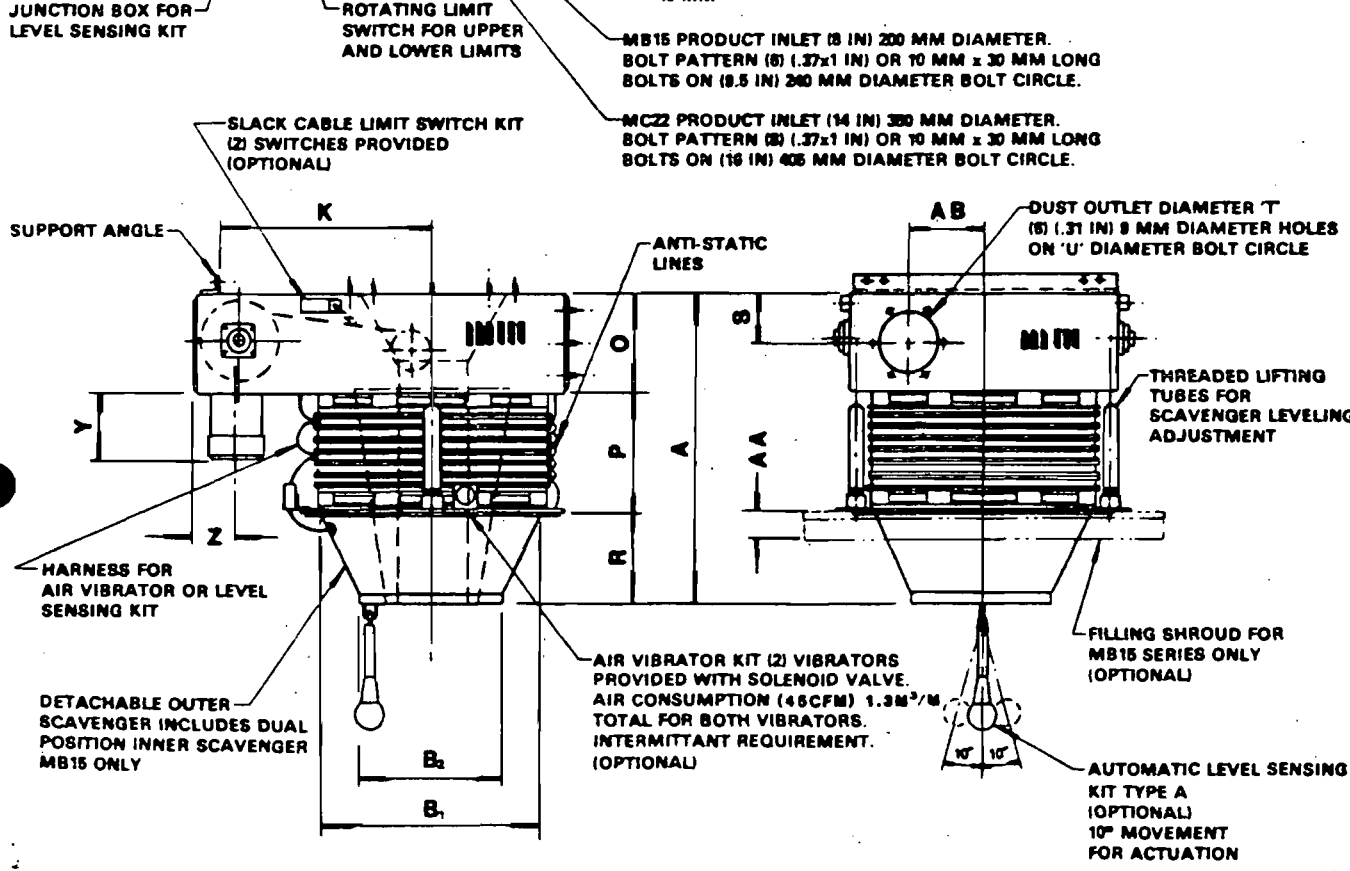

ACCESSORIES AVAILABLE	
ROTATING LIMIT SWITCH KIT	3 POSITION
AUTOMATIC LEVEL SENSING KIT	TYPE A
SLACK CABLE LIMIT SWITCH KIT	
AIR VIBRATOR KIT	
AIR MOTOR KIT	
FILLING SHROUD	ROUND OR SQUARE
	(24 IN) 600 MM OR (30 IN) 750 MM MB15 ONLY
AVAILABLE	1725 RPM 60 HZ 230/480-575 VAC
MOTOR VOLTAGES	1400 RPM 60 HZ 230/380-415-440

AVAILABLE MATERIALS OF CONSTRUCTION VENTURI AND SCAVENGER			
TYPE NUMBER	IN	MM	MATERIAL
2	.125	3	CARBON STEEL (STANDARD)
6	.125	3	ABRASION RESISTANT STEEL
10	.125	3	304 STAINLESS STEEL
12	.125	3	316 STAINLESS STEEL
14	.125	2	3003 ALUMINUM

DIM	MB15		MC22	
	IN	MM	IN	MM
A	24	600	30	750
A'	15	380	22	560
B	8	200	14	350
B'	21	530	27	680
C	20	500	26	650
D	20	500	26	650
E	29.5	750	34	850
F	16.5	420	21	530
G	18	450	24	600
H	17.37	440	21.25	540
I	18	450	20	515
J	1	25	1	25
K	1	25	1	25
L	1	25	1	25
M	1	25	1	25
N	1	25	1	25
O	1	25	1	25
P	10.2	260	13	330
Q	7	175	9	225
R	7	175	9	225
S	7	175	9	225
T	1	25	1	25
U	19	480	19	480
V	6	150	6	150
W	6	150	6	150
AA	6	150	6	150
AB	6	150	6	150

REF. SERIAL NO. JOB NO.
 PREPARED FOR: PO NO. DATE
 DRAWN BY: DATE
 CHECKED BY: DATE
 APPROVED BY: DATE
 DATE REVISION
 NO.