

Check Sheet

Company Name: United States Gypsum Company
Permit Number: AC 16-064349
PSD Number: _____
Permit Engineer: _____

Application:

- | | |
|--|--------------------------|
| <input checked="" type="checkbox"/> Initial Application | Cross References: |
| <input checked="" type="checkbox"/> Incompleteness Letters | <input type="checkbox"/> |
| <input checked="" type="checkbox"/> Responses | <input type="checkbox"/> |
| <input type="checkbox"/> Waiver of Department Action | <input type="checkbox"/> |
| <input type="checkbox"/> Department Response | |
| <input type="checkbox"/> Other | |

Intent:

- Intent to Issue
 - Notice of Intent to Issue
 - Technical Evaluation
 - BACT or LAER Determination
 - Unsigned Permit
- Correspondence with:
- EPA
 - Park Services
 - Other
- Proof of Publication
 - Petitions - (Related to extensions, hearings, etc.)
 - Waiver of Department Action
 - Other

Final

Determination:

- Final Determination
- Signed Permit
- BACT or LAER Determination
- Other

Post Permit Correspondence:

- Extensions/Amendments/Modifications
- Other

P 408 530 321

RECEIPT FOR CERTIFIED MAIL

NO INSURANCE COVERAGE PROVIDED—
NOT FOR INTERNATIONAL MAIL

(See Reverse)

PS Form 3811, Jan. 1979

1. SENDER: Complete items 1, 2, and 3.
Add your address in the "RETURN TO" space on reverse.

1. The following service is requested (check one.)

- Show to whom and date delivered..... \$
- Show to whom, date and address of delivery..... \$
- RESTRICTED DELIVERY
Show to whom and date delivered..... \$
- RESTRICTED DELIVERY.
Show to whom, date, and address of delivery \$

(CONSULT POSTMASTER FOR FEES)

2. ARTICLE ADDRESSED TO:
Mr. D. J. Nootens
6825 Evergreen Avenue
Jacksonville, FL 32208

3. ARTICLE DESCRIPTION:

REGISTERED NO.	CERTIFIED NO.	INSURED NO.
	P408530321	

(Always obtain signature of addressee or agent)

I have received the article described above.

SIGNATURE Addressee Authorized agent

Caroline Pourcious

4. DATE OF DELIVERY
6/6/83

5. ADDRESS (Complete only if requested)

6. UNABLE TO DELIVER BECAUSE:

CLERK'S INITIALS

PS Form 3800, Feb. 1982

Sent to Mr. D. J. Nootens	
Street and No.	
P.O., State and ZIP Code	
Postage	\$
Certified Fee	
Special Delivery Fee	
Restricted Delivery Fee	
Return Receipt Showing to whom and Date Delivered	
Return Receipt Showing to whom, Date, and Address of Delivery	
TOTAL Postage and Fees	\$
Postmark or Date 6/2/83	

STATE OF FLORIDA
DEPARTMENT OF ENVIRONMENTAL REGULATION

TWIN TOWERS OFFICE BUILDING
2600 BLAIR STONE ROAD
TALLAHASSEE, FLORIDA 32301-8241



BOB GRAHAM
GOVERNOR
VICTORIA J. TSCHINKEL
SECRETARY

May 31, 1984

CERTIFIED MAIL-RETURN RECEIPT REQUESTED

Mr. D. J. Nootens
Works Manager
United States Gypsum Company
6825 Evergreen Avenue
Jacksonville, Florida 32208

Dear Mr. Nootens:

Enclosed is Permit Number AC 16-64349, dated May 31, 1983, to United States Gypsum Company issued pursuant to Section 403, Florida Statutes.

Acceptance of the permit constitutes notice and agreement that the Department will periodically review this permit for compliance, including site inspections where applicable, and may initiate enforcement actions for violation of the conditions and requirements thereof.

Sincerely,

C. H. Fancy, P.E.
Deputy Bureau Chief
Bureau of Air Quality
Management

CHF/bjm

Enclosure

cc: Ragan M. Womack, P.E., United States Gypsum Company
John Ketteringham, DER Northeast District
Jerry Woosley, Duval County Bio-Environmental Services

FINAL DETERMINATION

United States Gypsum Company
6500 CFM Baghouse

Permit Number: AC 16-64349

Florida Department of Environmental Regulation
Bureau of Air Quality Management
Central Air Permitting

May 27, 1983

FINAL DETERMINATION

United States Gypsum Company's application for permit to construct a 6500 CFM baghouse dust collector in Jacksonville, Florida, has been reviewed by the Bureau of Air Quality Management. Public notice of the Department's Intent to Issue the construction permit was published in the Florida Times Union on April 13, 1983.

Copies of the preliminary determination have been available for public inspection at the Department's Northeast District Office in Jacksonville and the Bureau of Air Quality Management Office in Tallahassee.

There were no letters of response as a result of the public notice period.

The final action of the Department will be to issue the permit as noticed during the public notice period.

STATE OF FLORIDA
DEPARTMENT OF ENVIRONMENTAL REGULATION

TWIN TOWERS OFFICE BUILDING
2600 BLAIR STONE ROAD
TALLAHASSEE, FLORIDA 32301-8241



BOB GRAHAM
GOVERNOR
VICTORIA J. TSCHINKEL
SECRETARY

PERMITTEE: United States Gypsum Permit Number: AC 16-64349
Company Date of Issue:
6825 Evergreen Ave. Expiration Date: November 30, 1983
Jacksonville, FL County: Duval
32208 Latitude/Longitude: 30° 22' 52" N/
81° 38' 07" W
Project: 6500 CFM Baghouse

This permit is issued under the provisions of Chapter(s) 403, Florida Statutes, and Florida Administrative Code Rule(s) 17-2 and 17-4. The above named permittee is hereby authorized to perform the work or operate the facility shown on the application and approved drawing(s), plans, and other documents attached hereto or on file with the department and made a part hereof and specifically described as follows:

For the installation of a 6500 CFM Baghouse located at U. S. Gypsum chemical complex in Duval County, Florida. The UTM coordinates are 438.9 km East and 3361.2 km North. Construction shall be accordance with the attached permit application, and plans, documents and drawings except as otherwise noted on pages 5 and 6, "Specific Conditions."

Attachments:

Application to Construct Air Pollution Sources, DER Form 17-1.122
(16)

PERMITTEE: United States Gypsum I. D. Number:
Company Permit Number: AC 16-64349
Date of Issue:
Expiration Date: November 30, 1983

GENERAL CONDITIONS:

1. The terms, conditions, requirements, limitations, and restrictions set forth herein are "Permit Conditions" and as such are binding upon the permittee and enforceable pursuant to the authority of Sections 403.161, 403.727, or 403.859 through 403.861, Florida Statutes. The permittee is hereby placed on notice that the department will review this permit periodically and may initiate enforcement action for any violation of the "Permit Conditions" by the permittee, its agents, employees, servants or representatives.

2. This permit is valid only for the specific processes and operations applied for and indicated in the approved drawings or exhibits. Any unauthorized deviation from the approved drawings, exhibits, specifications, or conditions of this permit may constitute grounds for revocation and enforcement action by the department.

3. As provided in Subsections 403.087(6) and 403.722(5), Florida Statutes, the issuance of this permit does not convey any vested rights or any exclusive privileges. Nor does it authorize any injury to public or private property or any invasion of personal rights, nor any infringement of federal, state or local laws or regulations. This permit does not constitute a waiver of or approval of any other department permit that may be required for other aspects of the total project which are not addressed in the permit.

4. This permit conveys no title to land or water, does not constitute state recognition or acknowledgement of title, and does not constitute authority for the use of submerged lands unless herein provided and the necessary title or leasehold interests have been obtained from the state. Only the Trustees of the Internal Improvement Trust Fund may express state opinion as to title.

5. This permit does not relieve the permittee from liability for harm or injury to human health or welfare, animal, plant or aquatic life or property and penalties therefor caused by the construction or operation of this permitted source, nor does it allow the permittee to cause pollution in contravention of Florida Statutes and department rules, unless specifically authorized by an order from the department.

PERMITTEE: United States Gypsum
Company

I. D. Number:

Permit Number: AC 16-64349

Date of Issue:

Expiration Date: November 30, 1983

GENERAL CONDITIONS:

6. The permittee shall at all times properly operate and maintain the facility and systems of treatment and control (and related appurtenances) that are installed or used by the permittee to achieve compliance with the conditions of this permit, as required by department rules. This provision includes the operation of backup or auxiliary facilities or similar systems when necessary to achieve compliance with the conditions of the permit and when required by department rules.

7. The permittee, by accepting this permit, specifically agrees to allow authorized department personnel, upon presentation of credentials or other documents as may be required by law, access to the premises, at reasonable times, where the permitted activity is located or conducted for the purpose of:

- a. Having access to and copying any records that must be kept under the conditions of the permit;
- b. Inspecting the facility, equipment, practices, or operations regulated or required under this permit; and
- c. Sampling or monitoring any substances or parameters at any location reasonably necessary to assure compliance with this permit or department rules.

Reasonable time may depend on the nature of the concern being investigated.

8. If, for any reason, the permittee does not comply with or will be unable to comply with any condition or limitation specified in this permit, the permittee shall immediately notify and provide the department with the following information:

- a. a description of and cause of non-compliance; and
- b. the period of noncompliance, including exact dates and times; or, if not corrected, the anticipated time the noncompliance is expected to continue, and steps being taken to reduce, eliminate, and prevent recurrence of the noncompliance.

PERMITTEE: United States Gypsum I. D. Number:
Company Permit Number: AC 16-64349
Date of Issue:
Expiration Date: November 30, 1983

GENERAL CONDITIONS:

The permittee shall be responsible for any and all damages which may result and may be subject to enforcement action by the department for penalties or revocation of this permit.

9. In accepting this permit, the permittee understands and agrees that all records, notes, monitoring data and other information relating to the construction or operation of this permitted source, which are submitted to the department, may be used by the department as evidence in any enforcement case arising under the Florida Statutes or department rules, except where such use is proscribed by Sections 403.73 and 403.111, Florida Statutes.

10. The permittee agrees to comply with changes in department rules and Florida Statutes after a reasonable time for compliance, provided however, the permittee does not waive any other rights granted by Florida Statutes or department rules.

11. This permit is transferable only upon department approval in accordance with Florida Administrative Code Rules 17-4.12 and 17-30.30, as applicable. The permittee shall be liable for any non-compliance of the permitted activity until the transfer is approved by the department.

12. This permit is required to be kept at the work site of the permitted activity during the entire period of construction or operation.

13. This permit also constitutes:

- () Determination of Best Available Control Technology (BACT)
- () Determination of Prevention of Significant Deterioration (PSD)
- () Compliance with New Source Performance Standards.

14. The permittee shall comply with the following monitoring and record keeping requirements:

- a. Upon request, the permittee shall furnish all records and plans required under department rules. The retention period for all records will be extended automatically, unless otherwise stipulated by the department, during the course of any unresolved enforcement action.

PERMITTEE: United States Gypsum
Company

I. D. Number:
Permit Number: AC 16-64349
Date of Issue:
Expiration Date: November 30, 1983

GENERAL CONDITIONS:

- b. The permittee shall retain at the facility or other location designated by this permit records of all monitoring information (including all calibration and maintenance records and all original strip chart recordings for continuous monitoring instrumentation), copies of all reports required by this permit, and records of all data used to complete the application for this permit. The time period of retention shall be at least three years from the date of the sample, measurement, report or application unless otherwise specified by department rule.
- c. Records of monitoring information shall include:
 - the date, exact place, and time of sampling or measurements;
 - the person responsible for performing the sampling or measurements;
 - the date(s) analyses were performed;
 - the person responsible for performing the analyses;
 - the analytical techniques or methods used; and
 - the results of such analyses.

15. When requested by the department, the permittee shall within a reasonable time furnish any information required by law which is needed to determine compliance with the permit. If the permittee becomes aware that relevant facts were not submitted or were incorrect in the permit application or in any report to the department, such facts or information shall be submitted or corrected promptly.

SPECIFIC CONDITIONS:

1. The maximum emissions rate for the 6500 CFM bag collector system shall not exceed 1.11 lb/hr and 3.46 ton/yr.
2. The unit shall be allowed to operate 6240 hours per year.

PERMITTEE: United States Gypsum
Company

I. D. Number:
Permit Number: AC 16-64349
Expiration Date: November 30, 1983

SPECIFIC CONDITIONS:

3. Visible emissions shall not exceed 5% opacity. Compliance with the opacity limitation will be determined by reference Method 9. The Department will be notified 30 days in advance of the compliance test. The test will be conducted at 90 to 100% capacity.
4. Reasonable precautions to prevent fugitive particulate emissions during construction such as coating or spraying roads and construction sites used by contractors will be taken by the applicant.
5. The applicant shall report any delays in construction and completion of this unit to the Department's Northeast District Office.
6. The applicant will demonstrate compliance with the conditions of the construction permit, and submit a complete application for an operating permit to the Department's Northeast District Office prior to 90 days of the expiration date of the construction permit. The applicant may continue to operate in compliance with all terms of the construction permit until its expiration date or issuance of an operating permit.
7. Upon obtaining an operating permit, the applicant will be required to submit periodic test reports on the actual operation and emissions of the facility.
8. Construction, operation and maintenance should reasonably conform to plans submitted in the application.
9. The source shall comply with the provisions and requirements of the attached general conditions.

PERMITTEE: United States Gypsum
Company

I. D. Number:
Permit Number: AC 16-64349
Date of Issue:
Expiration Date: November 30, 1983

SPECIFIC CONDITIONS:

Issued this 31 day of May, 1983

STATE OF FLORIDA DEPARTMENT OF
ENVIRONMENTAL REGULATION



VICTORIA J. TSCHINKEL, Secretary

_____ pages attached.

State of Florida
DEPARTMENT OF ENVIRONMENTAL REGULATION

INTEROFFICE MEMORANDUM

For Routing To District Offices And/Or To Other Than The Addressee		
To: _____	Loctn.: _____	
To: _____	Loctn.: _____	
To: _____	Loctn.: _____	
From: _____	Date: _____	
Reply Optional []	Reply Required []	Info. Only []
Date Due: _____	Date Due: _____	

TO: Victoria J. Tschinkel
FROM: Clair Fancy *Clair Fancy*
DATE: May 27, 1983
SUBJ: Approval of Air Construction Permit

Attached please find one Air Construction Permit for which the applicant is United States Gypsum Company. The construction proposed is the installation of a 6500 CFM baghouse dust collector at their existing facility in Jacksonville, Duval County, Florida.

Day 90, after which the permit would be issued by default, is June 2, 1983.

The Bureau recommends your approval and signature.

CF/pa

Attachment



FLORIDA PUBLISHING COMPANY
Publishers
JACKSONVILLE, DUVAL COUNTY, FLORIDA

STATE OF FLORIDA }
COUNTY OF DUVAL }

Before the undersigned authority personally appeared _____

George A. Dan who on oath says that he is
Retail Advertising Supervisor of The Florida Times-Union, and
Jacksonville Journal, daily newspapers published at Jacksonville in Duval County,
Florida; that the attached copy of advertisement, being a _____

Legal Notice

in the matter of Notice of Proposed Agency Action

in the _____ Court,

was published in The Florida Times Union

in the issues of April 13, 1983

Affiant further says that the said The Florida Times-Union and Jacksonville Journal are each newspapers published at Jacksonville, in said Duval County, Florida, and that the said newspapers have each heretofore been continuously published in said Duval County, Florida, The Florida Times-Union each day, and Jacksonville Journal each day except Sundays, and each has been entered as second class mail matter at the postoffice in Jacksonville, in said Duval County, Florida, for a period of one year next preceding the first publication of the attached copy of advertisement; and affiant further says that he has neither paid nor promised any person, firm or corporation any discount, rebate, commission or refund for the purpose of securing this advertisement for publication in said newspaper.

Sworn to and subscribed before me
this 13th day of April 1983

Notary Public, State of Florida at Large.

Signature of George A. Dan

My Commission Expires July 9, 1986
Notary Public, State of Florida
Bonded Thru Troy Fair Insurance, Inc.

NOTICE OF PROPOSED AGENCY ACTION
The Department of Environmental Regulation gives notice of its intent to issue a permit to U.S. Gypsum Company to install a 6500 CFM baghouse dust collector at their existing facility in Jacksonville, Duval County, Florida. A determination of Best Available Control Technology (BACT) was not required.
A person who is substantially affected by the Department's proposed permitting decision may request a hearing in accordance with Section 102.57, Florida Statutes, and Chapters 17-1 and 28-5, Florida Administrative Code. The request for hearing must be filed (received) in the Office of General Counsel of the Department at 2600 Blair Stone Road, Twin Towers Office Building, Tallahassee, Florida 32301, within fourteen (14) days of publication of this notice. Failure to file a request for hearing within this time period shall constitute a waiver of any right such person may have to request a hearing under Section 120.57, Florida Statutes.
The application, technical evaluation and department intent are available for public inspection during normal business hours, 8:00 a.m. to 5:00 p.m., Monday through Friday, except legal holidays, at the following locations:
DER Bureau of Air Quality Management
2600 Blair Stone Road
Tallahassee, Florida 32301
DER Northeast District
3426 Bills Road
Jacksonville, Florida 32207
Jacksonville Division of Biological Services
515 West 6th Street
Jacksonville, Florida 32206
Comments on this action shall be submitted in writing to Bill Thomas of Tallahassee office within thirty (30) days of this notice.

DER
APR 19 1983
BAQM



UNITED STATES ENVIRONMENTAL PROTECTION AGENCY

REGION IV

345 COURTLAND STREET
ATLANTA, GEORGIA 30365

April 8, 1983

DER

APR 11 1983

BAQM

Mr. Bruce Mitchell DER/BAQM
Florida Department of Environmental Regulation
Room 601
2600 Blair Stone Road
Twin Towers Office Building
Tallahassee, Florida 32301

Dear Mr. Mitchell:

Reference our telephone conversation regarding the public notice on United States Gypsum Company, enclosed is a copy of the affidavit from the Florida Times-Union showing proof of publication.

If I can be of further assistance, please contact me.

Sincerely yours,

A handwritten signature in cursive script that reads "Earline C. Hanson".

Earline C. Hanson
Environmental Protection Assistant
Office of Policy and Management

Enclosure



Roosevelt

FLORIDA PUBLISHING COMPANY

Publishers

JACKSONVILLE, DUVAL COUNTY, FLORIDA

STATE OF FLORIDA }
COUNTY OF DUVAL }

Before the undersigned authority personally appeared _____

George A. Fan

who on oath says that he is

Retail Advertising Supervisor

of The Florida Times-Union, and

Jacksonville Journal, daily newspapers published at Jacksonville in Duval County,

Florida; that the attached copy of advertisement, being a _____

Legal Notice

in the matter of _____

in the _____ Court,

The Florida Times Union

was published in _____

in the issues of March 10, 1986

Affiant further says that the said The Florida Times-Union and Jacksonville Journal are each newspapers published at Jacksonville, in said Duval County, Florida, and that the said newspapers have each heretofore been continuously published in said Duval County, Florida, The Florida Times-Union each day, and Jacksonville Journal each day except Sundays, and each has been entered as second class mail matter at the postoffice in Jacksonville, in said Duval County, Florida, for a period of one year next preceding the first publication of the attached copy of advertisement; and affiant further says that he has neither paid nor promised any person, firm or corporation any discount, rebate, commission or refund for the purpose of securing this advertisement for publication in said newspaper.

Sworn to and subscribed before me
the _____ day of _____

James D. King
Notary Public,
State of Florida at Large.

George A. Fan

My Commission Expires _____
Notary Public, State of Florida
My Commission Expires July 9, 1986
Bonded thru Troy Fain Insurance, Inc.

NOTICE OF PROPOSED AGENCY ACTION
The Department of Environmental Regulation gives notice of its intent to issue a permit to United States Gypsum Company, 6825 Evergreen Avenue, Jacksonville, Florida 32206.
A person who is substantially affected by the Department's proposed permitting decision may request a hearing in accordance with Section 120.57, Florida Statutes, and Chapters 17-1 and 28-5, Florida Administrative Code. The request for hearing must be filed (received) in the office of General Counsel of the Department at 2400 Blair Stone Road, Twin Towers Office Building, Tallahassee, Florida 32301, within fourteen (14) days of publication of this notice. Failure to file a request for hearing within this time period shall constitute a waiver of any right such person may have to request a hearing under Section 120.57, Florida Statutes.
The application is available for public inspection during normal business hours, 8:00 a.m. to 5:00 p.m., Monday through Friday, except legal holidays, at the following locations:
Florida Department of Environmental Regulation
Northeast District
3426 Bills Road
Jacksonville, Florida 32207
City of Jacksonville
Bio-Environmental Services Division
515 W. 6th Street
Jacksonville, Florida 32206
Persons wishing to comment on any aspect of this action are required to submit their comments in writing to the addresses above within thirty (30) days of publication of this notice.

FACILITIES PERFORMANCE DIVISION
MAR 23 1983
ATLANTA, GA.

No. 0157982
 RECEIPT FOR CERTIFIED MAIL
 NO INSURANCE COVERAGE PROVIDED—
 NOT FOR INTERNATIONAL MAIL
 (See Reverse)

SENT TO Mr. D. J. Nootens	
STREET AND NO.	
P.O., STATE AND ZIP CODE	
POSTAGE	\$
<input checked="" type="checkbox"/> CERTIFIED FEE	¢
<input type="checkbox"/> SPECIAL DELIVERY	¢
<input type="checkbox"/> RESTRICTED DELIVERY	¢
OPTIONAL SERVICES	
RETURN RECEIPT SERVICE	
SHOW TO WHOM AND DATE DELIVERED	¢
SHOW TO WHOM, DATE, AND ADDRESS OF DELIVERY	¢
SHOW TO WHOM AND DATE DELIVERED WITH RESTRICTED DELIVERY	¢
SHOW TO WHOM, DATE AND ADDRESS OF DELIVERY WITH RESTRICTED DELIVERY	¢
TOTAL POSTAGE AND FEES	\$
POSTMARK OR DATE	
3/3/83 3/7/83	

PS Form 3800, Apr. 1976

PS Form 3811, Jan. 1979

SENDER: Complete items 1, 2, and 3. Add your address in the "RETURN TO" space on reverse.

1. The following service is requested (check one.)
 Show to whom and date delivered.....¢
 Show to whom, date and address of delivery.....¢
 RESTRICTED DELIVERY
 Show to whom and date delivered.....¢
 RESTRICTED DELIVERY.
 Show to whom, date, and address of delivery \$.....¢

(CONSULT POSTMASTER FOR FEES)

2. ARTICLE ADDRESSED TO:
 Mr. D. J. Nootens
 6825 Evergreen Avenue
 Jacksonville, FL 32208

3. ARTICLE DESCRIPTION:
 REGISTERED NO. CERTIFIED NO. INSURED NO.
 0157982

(Always obtain signature of addressee or agent)

I have received the article described above.
 SIGNATURE Addressee Authorized agent
Rddy B. [Signature]

4. DATE OF DELIVERY POSTMARK
 3/7/83 JACK

5. ADDRESS (Complete only if required)

6. UNABLE TO DELIVER BECAUSE CLERK'S INITIALS

GPO : 1979-300-459

RETURN RECEIPT, REGISTERED, INSURED AND CERTIFIED MAIL

STATE OF FLORIDA

DEPARTMENT OF ENVIRONMENTAL REGULATION

TWIN TOWERS OFFICE BUILDING
2600 BLAIR STONE ROAD
TALLAHASSEE, FLORIDA 32301-8241



BOB GRAHAM
GOVERNOR

VICTORIA J. TSCHINKEL
SECRETARY

March 3, 1983

CERTIFIED MAIL-RETURN RECEIPT REQUESTED

Mr. D. J. Nootens
Works Manager
United States Gypsum Company
6825 Evergreen Avenue
Jacksonville, Florida 32208

Dear Mr. Nootens:

Attached is one copy of the Technical Evaluation and Preliminary Determination, and proposed permit for the installation of a 6500 CFM baghouse dustcollector at your facility in Jacksonville, Florida.

Before final action can be taken on your proposed permit, you are required by Florida Administrative Code Rule 17-1.62(3) to publish the attached Notice of Proposed Agency Action in the legal advertising section of a newspaper of general circulation in Duval County no later than fourteen days after receipt of this letter. The department must be provided with proof of publication within seven days of the date the notice is published. Failure to publish the notice will be grounds for denial of the permit.

The Preliminary Determination and proposed permit constitute a proposed action of the department and is subject to administrative hearing under the provisions of Chapter 120, Florida Statutes, if requested within fourteen days from receipt of this letter. Any petition for hearing must comply with the requirements of Florida Administrative Code Rule 28-5.201 and be filed with the Office of General Counsel, Florida Department of Environmental Regulation, Twin Towers Office Building, 2600 Blair Stone Road, Tallahassee, Florida 32301. Failure to file a request for hearing within fourteen days shall constitute a waiver of your right to a hearing. Filing is deemed complete upon receipt by the Office of General Counsel.

Mr. D. J. Nootens
March 3, 1983
Page Two

Please submit, in writing, any comments which you wish to have considered concerning the department's proposed action to Bill Thomas of the Bureau of Air Quality Management.

Sincerely,



C. H. Fancy, P.E.
Deputy Chief
Bureau of Air Quality
Management

CHF/pa

Attachment

cc: Mr. Ragan M. Womack, U.S. Gypsum Company
Mr. John Ketteringham, DER Northeast District
Mr. Jerry Woosley, Jacksonville Division of
Environmental Services

Preliminary Determination
and
Technical Evaluation

United States Gypsum Company
6500 CFM Baghouse
Duval County, Florida

State Permit Number
AC 16-64349

Florida Department of Environmental Regulation
Bureau of Air Quality Management
Central Air Permitting

NOTICE OF PROPOSED AGENCY ACTION

The Department of Environmental Regulation gives notice of its intent to issue a permit to U.S. Gypsum Company to install a 6500 CFM baghouse dust collector at their existing facility in Jacksonville, Duval County, Florida. A determination of Best Available Control Technology (BACT) was not required.

A person who is substantially affected by the Department's proposed permitting decision may request a hearing in accordance with Section 120.57, Florida Statutes, and Chapters 17-1 and 28-5, Florida Administrative Code. The request for hearing must be filed (received) in the Office of General Counsel of the Department at 2600 Blair Stone Road, Twin Towers Office Building, Tallahassee, Florida 32301, within fourteen (14) days of publication of this notice. Failure to file a request for hearing within this time period shall constitute a waiver of any right such person may have to request a hearing under Section 120.57, Florida Statutes.

The application, technical evaluation and department intent are available for public inspection during normal business hours, 8:00 a.m. to 5:00 p.m., Monday through Friday, except legal holidays, at the following locations:

DER Bureau of Air Quality Management	DER Northeast District
2600 Blair Stone Road	3426 Bills Road
Tallahassee, Florida 32301	Jacksonville, Florida 32207

Jacksonville Division of Bio-Environmental Services
515 West 6th Street
Jacksonville, Florida 32206

Comments on this action shall be submitted in writing to Bill Thomas of Tallahassee office within thirty (30) days of this notice.

RULES OF THE ADMINISTRATIVE COMMISSION
MODEL RULES OF PROCEDURE
CHAPTER 28-5
DECISIONS DETERMINING SUBSTANTIAL INTERESTS

28-5.15 Requests for Formal and Informal Proceedings

- (1) Requests for proceedings shall be made by petition to the agency involved. Each petition shall be printed typewritten or otherwise duplicated in legible form on white paper of standard legal size. Unless printed, the impression shall be on one side of the paper only and lines shall be double spaced and indented.
- (2) All petitions filed under these rules should contain:
 - (a) The name and address of each agency affected and each agency's file or identification number, if known;
 - (b) The name and address of the petitioner or petitioners;
 - (c) All disputed issues of material fact. If there are none, the petition must so indicate;
 - (d) A concise statement of the ultimate facts alleged, and the rules, regulations and constitutional provisions which entitle the petitioner to relief;
 - (e) A statement summarizing any informal action taken to resolve the issues, and the results of that action;
 - (f) A demand for the relief to which the petitioner deems himself entitled; and
 - (g) Such other information which the petitioner contends is material.

I. SYNOPSIS OF APPLICATION

A. Name and Address of Applicant

United States Gypsum Co.
6825 Evergreen Ave.
Jacksonville, Fl 32208

B. Source Location

The proposed source is located at 6825 Evergreen Avenue in the city of Jacksonville, Duval County, Florida. The UTM coordinates are 438.9 Km East and 3361.20 Km North.

C. Project Description

The applicant proposes to install a baghouse dust collector to control fugitive emissions from the existing McLanahan roll crusher.

At the present time all fugitive emissions are vented to the inside of the building. This source will be identified as BH-7 as indicated in the airborne emissions' flow diagram.

II. RULE APPLICABILITY

The proposed project is subject to preconstruction review under the provisions of Chapter 403, Florida Statutes and, Chapter 17-2 Florida Administrative Code. Specifically, the proposed project involves a minor source for particulate matter (PM). Potential emissions of PM are 3.46 tons per year.

The proposed source location, Duval County, is in an area currently designated as attainment in accordance with Section 17-2.420, FAC for SO₂, NO_x, CO and nonattainment for particulate matter and ozone in accordance with Section 17-2.410, FAC.

The proposed source will be a minor modification for particulate matter (PM). Emissions of PM would result in no significant net emission increase of this pollutant as listed in Table 500 Regulated Air Pollutant Significant Emission Rates. Therefore, the proposed source is exempt from the provisions of Section 17-2.500, FAC, Prevention of Significant Deterioration.

Due to the potential emissions totalling 3.46 tons per year of PM and no volatile organic compounds (VOC) emissions, the proposed source is exempt from provisions of Section 17-2.510, New Source Review for Nonattainment Areas.

Since this control device (baghouse dust collector) will be installed as a reasonable precaution to prevent unconfined emissions of particulate matter, the proposed project will be permitted under 17-2.610(3)(c)6, FAC, Unconfined Emissions of Particulate matter.

The proposed source is also subject to provisions of Section 17-2.520, FAC. Permitting Requirements of Sources not Subject to Prevention of Significant Deterioration or Nonattainment Requirements and subsection 17-2.700(1)(d)6, FAC, Alternate Test Procedures not Subject to Prior Approval.

III. SOURCE IMPACT ANALYSIS

A. Emission Limitations

The installation of the proposed 6500 CFM baghouse will provide the plant with additional dust collection capacity and reduce fugitive emissions which are currently vented to the inside of the building. The emissions from this source are as follows:

Pollutant	Controlled		Uncontrolled	
	lb/hr	ton/yr	lb/yr	ton/yr
PM	1.11	3.46	1110	3463.2

Control efficiency of 99% and 0.02 gr/dscf

B. Air Quality

No ambient monitoring or modeling is required to provide reasonable assurance that ambient air standards will not be violated.

IV. CONCLUSIONS

Based on review of the data submitted by U.S. Gypsum Co., the FDER concludes that compliance with all applicable state air quality regulations will be achieved provided certain specific conditions are met. The impact of the emissions from this source will not cause or contribute to a violation of any ambient air quality standard.

STATE OF FLORIDA
DEPARTMENT OF ENVIRONMENTAL REGULATION

TWIN TOWERS OFFICE BUILDING
2600 BLAIR STONE ROAD
TALLAHASSEE, FLORIDA 32301-8241



BOB GRAHAM
GOVERNOR

VICTORIA J. TSCHINKEL
SECRETARY

PERMITTEE: United States Gypsum Permit Number: AC 16-64349
Company Date of Issue:
6825 Evergreen Ave. Expiration Date: November 30, 1983
Jacksonville, FL County: Duval
32208 Latitude/Longitude: 30° 22' 52" N/
81° 38' 07" W
Project: 6500 CFM Baghouse

This permit is issued under the provisions of Chapter(s) 403, Florida Statutes, and Florida Administrative Code Rule(s) 17-2 and 17-4. The above named permittee is hereby authorized to perform the work or operate the facility shown on the application and approved drawing(s), plans, and other documents attached hereto or on file with the department and made a part hereof and specifically described as follows:

For the installation of a 6500 CFM Baghouse located at U. S. Gypsum chemical complex in Duval County, Florida. The UTM coordinates are 438.9 km East and 3361.2 km North. Construction shall be accordance with the attached permit application, and plans, documents and drawings except as otherwise noted on pages 5 and 6, "Specific Conditions."

Attachments:

Application to Construct Air Pollution Sources, DER Form 17-1.122
(16)

PERMITTEE: United States Gypsum I. D. Number:
Company Permit Number: AC 16-64349
Date of Issue:
Expiration Date: November 30, 1983

GENERAL CONDITIONS:

1. The terms, conditions, requirements, limitations, and restrictions set forth herein are "Permit Conditions" and as such are binding upon the permittee and enforceable pursuant to the authority of Sections 403.161, 403.727, or 403.859 through 403.861, Florida Statutes. The permittee is hereby placed on notice that the department will review this permit periodically and may initiate enforcement action for any violation of the "Permit Conditions" by the permittee, its agents, employees, servants or representatives.

2. This permit is valid only for the specific processes and operations applied for and indicated in the approved drawings or exhibits. Any unauthorized deviation from the approved drawings, exhibits, specifications, or conditions of this permit may constitute grounds for revocation and enforcement action by the department.

3. As provided in Subsections 403.087(6) and 403.722(5), Florida Statutes, the issuance of this permit does not convey any vested rights or any exclusive privileges. Nor does it authorize any injury to public or private property or any invasion of personal rights, nor any infringement of federal, state or local laws or regulations. This permit does not constitute a waiver of or approval of any other department permit that may be required for other aspects of the total project which are not addressed in the permit.

4. This permit conveys no title to land or water, does not constitute state recognition or acknowledgement of title, and does not constitute authority for the use of submerged lands unless herein provided and the necessary title or leasehold interests have been obtained from the state. Only the Trustees of the Internal Improvement Trust Fund may express state opinion as to title.

5. This permit does not relieve the permittee from liability for harm or injury to human health or welfare, animal, plant or aquatic life or property and penalties therefor caused by the construction or operation of this permitted source, nor does it allow the permittee to cause pollution in contravention of Florida Statutes and department rules, unless specifically authorized by an order from the department.

PERMITTEE: United States Gypsum
Company

I. D. Number:

Permit Number: AC 16-64349

Date of Issue:

Expiration Date: November 30, 1983

GENERAL CONDITIONS:

6. The permittee shall at all times properly operate and maintain the facility and systems of treatment and control (and related appurtenances) that are installed or used by the permittee to achieve compliance with the conditions of this permit, as required by department rules. This provision includes the operation of backup or auxiliary facilities or similar systems when necessary to achieve compliance with the conditions of the permit and when required by department rules.

7. The permittee, by accepting this permit, specifically agrees to allow authorized department personnel, upon presentation of credentials or other documents as may be required by law, access to the premises, at reasonable times, where the permitted activity is located or conducted for the purpose of:

- a. Having access to and copying any records that must be kept under the conditions of the permit;
- b. Inspecting the facility, equipment, practices, or operations regulated or required under this permit; and
- c. Sampling or monitoring any substances or parameters at any location reasonably necessary to assure compliance with this permit or department rules.

Reasonable time may depend on the nature of the concern being investigated.

8. If, for any reason, the permittee does not comply with or will be unable to comply with any condition or limitation specified in this permit, the permittee shall immediately notify and provide the department with the following information:

- a. a description of and cause of non-compliance; and
- b. the period of noncompliance, including exact dates and times; or, if not corrected, the anticipated time the noncompliance is expected to continue, and steps being taken to reduce, eliminate, and prevent recurrence of the noncompliance.

PERMITTEE: United States Gypsum I. D. Number:
Company

Permit Number: AC 16-64349

Date of Issue:

Expiration Date: November 30, 1983

GENERAL CONDITIONS:

The permittee shall be responsible for any and all damages which may result and may be subject to enforcement action by the department for penalties or revocation of this permit.

9. In accepting this permit, the permittee understands and agrees that all records, notes, monitoring data and other information relating to the construction or operation of this permitted source, which are submitted to the department, may be used by the department as evidence in any enforcement case arising under the Florida Statutes or department rules, except where such use is proscribed by Sections 403.73 and 403.111, Florida Statutes.

10. The permittee agrees to comply with changes in department rules and Florida Statutes after a reasonable time for compliance, provided however, the permittee does not waive any other rights granted by Florida Statutes or department rules.

11. This permit is transferable only upon department approval in accordance with Florida Administrative Code Rules 17-4.12 and 17-30.30, as applicable. The permittee shall be liable for any non-compliance of the permitted activity until the transfer is approved by the department.

12. This permit is required to be kept at the work site of the permitted activity during the entire period of construction or operation.

13. This permit also constitutes:

- () Determination of Best Available Control Technology (BACT)
- () Determination of Prevention of Significant Deterioration (PSD)
- () Compliance with New Source Performance Standards.

14. The permittee shall comply with the following monitoring and record keeping requirements:

- a. Upon request, the permittee shall furnish all records and plans required under department rules. The retention period for all records will be extended automatically, unless otherwise stipulated by the department, during the course of any unresolved enforcement action.

PERMITTEE: United States Gypsum
Company

I. D. Number:
Permit Number: AC 16-64349
Date of Issue:
Expiration Date: November 30, 1983

GENERAL CONDITIONS:

- b. The permittee shall retain at the facility or other location designated by this permit records of all monitoring information (including all calibration and maintenance records and all original strip chart recordings for continuous monitoring instrumentation), copies of all reports required by this permit, and records of all data used to complete the application for this permit. The time period of retention shall be at least three years from the date of the sample, measurement, report or application unless otherwise specified by department rule.
- c. Records of monitoring information shall include:
 - the date, exact place, and time of sampling or measurements;
 - the person responsible for performing the sampling or measurements;
 - the date(s) analyses were performed;
 - the person responsible for performing the analyses;
 - the analytical techniques or methods used; and
 - the results of such analyses.

15. When requested by the department, the permittee shall within a reasonable time furnish any information required by law which is needed to determine compliance with the permit. If the permittee becomes aware that relevant facts were not submitted or were incorrect in the permit application or in any report to the department, such facts or information shall be submitted or corrected promptly.

SPECIFIC CONDITIONS:

1. The maximum emissions rate for the 6500 CFM bag collector system shall not exceed 1.11 lb/hr and 3.46 ton/yr.
2. The unit shall be allowed to operate 6240 hours per year.

PERMITTEE: United States Gypsum
Company

I. D. Number:
Permit Number: AC 16-64349
Expiration Date: November 30, 1983

SPECIFIC CONDITIONS:

3. Visible emissions shall not exceed 5% opacity. Compliance with the opacity limitation will be determined by reference Method 9. The Department will be notified 30 days in advance of the compliance test. The test will be conducted at 90 to 100% capacity.
4. Reasonable precautions to prevent fugitive particulate emissions during construction such as coating or spraying roads and construction sites used by contractors will be taken by the applicant.
5. The applicant shall report any delays in construction and completion of this unit to the Department's Northeast District Office.
6. The applicant will demonstrate compliance with the conditions of the construction permit, and submit a complete application for an operating permit to the Department's Northeast District Office prior to 90 days of the expiration date of the construction permit. The applicant may continue to operate in compliance with all terms of the construction permit until its expiration date or issuance of an operating permit.
7. Upon obtaining an operating permit, the applicant will be required to submit periodic test reports on the actual operation and emissions of the facility.
8. Construction, operation and maintenance should reasonably conform to plans submitted in the application.
9. The source shall comply with the provisions and requirements of the attached general conditions.

PERMITTEE: United States Gypsum
Company

I. D. Number:
Permit Number: AC 16-64349
Date of Issue:
Expiration Date: November 30, 1983

SPECIFIC CONDITIONS:

Issued this ___ day of _____, 1983

STATE OF FLORIDA DEPARTMENT OF
ENVIRONMENTAL REGULATION

VICTORIA J. TSCHINKEL, Secretary

___ pages attached.

UNITED STATES GYPSUM COMPANY //

Post Office Box 3197/Jacksonville, Florida 32206-0197 //

January 11, 1983

Department of Environmental Regulation
Twin Towers Office Building
2600 Blair Stone Road
Tallahassee, Florida 32301-8241

Attention: Mr. C. H. Fancy, P.E., Deputy Bureau Chief
Bureau of Air Quality Management

Reference: Air Construction Permit Application AC 16-64349

Dear Sir:

Enclosed is our check for \$100.00 for processing fee for the above referenced construction permit application, inadvertently left off of our application.

Very truly yours,

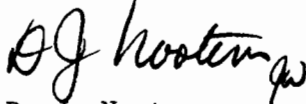

D. J. Nootens
Works Manager

DJN:jw

Encl.

DER
JAN 13 1983
BAQM

STATE OF FLORIDA
DEPARTMENT OF ENVIRONMENTAL REGULATION

TWIN TOWERS OFFICE BUILDING
2600 BLAIR STONE ROAD
TALLAHASSEE, FLORIDA 32301-8241

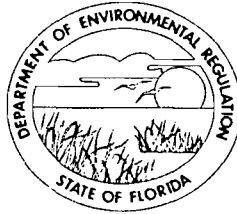

BOB GRAHAM
GOVERNOR
VICTORIA J. TSCHINKEL
SECRETARY

~~January 4, 1983~~

CERTIFIED MAIL

Mr. D. J. Nootens, Work Manager
United States Gypsum Company
6825 Evergreen Avenue
Jacksonville, Florida 32208

Dear Mr. Nootens:

RE: Air Construction Permit Application AC 16-64349

The Bureau of Air Quality Management has received your application for a permit to construct a 6500 CFM baghouse at your facility, in Jacksonville, Florida.

The processing fee for your project was not included with the application. In accordance with Section 17-4.05(4)(a)5., FAC, the construction permit for a source having potential emissions of less than 25 tons per year of any single pollutant is \$100.00. Based on this, you need to send a check for \$100.00 to our Tallahassee office.

As soon as the requested fee is received at this office, we will resume processing your application.

If you have any questions on this request, please contact Teresa M. Heron of this office at (904)488-1344.

Sincerely,

C. H. Fancy, P.E.
Deputy Bureau Chief
Bureau of Air Quality
Management

A.O.A. Check No.	38370
F.O.B.	✓
Price	✓
Terms	✓
Quantities and	
\$Amount Checked	✓ RAB
APPROVAL TO PAY	

CHF/TH/bjm



UNITED STATES GYPSUM COMPANY
JACKSONVILLE, FL

PLANT DISBURSEMENT ACCOUNT

TO: THE NORTHERN TRUST COMPANY, CHICAGO, ILLINOIS

No. 38370

2-15
710

DATE: JANUARY 10, 1983

AMOUNT
\$100.00

PAY TO THE ORDER OF Department Of Environmental Regulation

UNITED STATES GYPSUM COMPANY
AUTHORIZED SIGNATURE

GA Lewis



STATE OF FLORIDA
DEPARTMENT OF ENVIRONMENTAL REGULATION

No. 38642

RECEIPT FOR APPLICATION FEES AND MISCELLANEOUS REVENUE

Received from United States Gypsum Company Date January 13, 1983

Address P.O. Box 3177 Jacksonville FL 32206 Dollars \$ 100.00

Applicant Name & Address Same as above

Source of Revenue _____

Revenue Code 0101 Application Number AC No-64349

By Patricia J. Adams

CHECK NUMBER	DATE	PAYEE	INVOICE NUMBER	NET AMOUNT	TOTAL CHECK
38370	1/10	DEPARTMENT OF ENVIRONMENTAL REGULATION		100.00	

U.S.G. 50723 REV. 1-74

UNITED STATES GYPSUM COMPANY
JACKSONVILLE, FL
PLANT DISBURSEMENT ACCOUNT

DETACH AND RETAIN STUB

PS Form 3811, Jan. 1979
RETURN RECEIPT, REGISTERED, INSURED AND CERTIFIED MAIL

SENDER: Complete items 1, 2, and 3.
Add your address in the "RETURN TO" space on reverse.

1. The following service is requested (check one.)
 Show to whom and date delivered.....¢
 Show to whom, date and address of delivery....¢
 RESTRICTED DELIVERY
 Show to whom and date delivered.....¢
 RESTRICTED DELIVERY,
 Show to whom, date, and address of delivery. \$ _____
 (CONSULT POSTMASTER FOR FEES)

2. ARTICLE ADDRESSED TO:
 Mr. D. J. Nootens, U.S. Gypsum
 6825 Evergreen Ave.
 Jacksonville, FL 32208

3. ARTICLE DESCRIPTION:

REGISTERED NO.	CERTIFIED NO.	INSURED NO.
	0157896	

 (Always obtain signature of addressee or agent)
 I have received the article described above.
 SIGNATURE Addressee Authorized agent
Caroline Pours

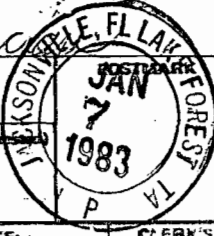
4. DATE OF DELIVERY

5. ADDRESS (Complete only if requested)

6. UNABLE TO DELIVER BECAUSE: _____ CLERK'S INITIALS _____

No. 0157896
 RECEIPT FOR CERTIFIED MAIL
 NO INSURANCE COVERAGE PROVIDED—
 NOT FOR INTERNATIONAL MAIL
 (See Reverse)

SENT TO
 Mr. D. J. Nootens
 STREET AND NO.
 6825 Evergreen Ave.
 P.O., STATE AND ZIP CODE
 Jacksonville, FL 32208

POSTAGE	\$	¢
CERTIFIED FEE		¢
SPECIAL DELIVERY		¢
RESTRICTED DELIVERY		¢
OPTIONAL SERVICES		¢
RETURN RECEIPT SERVICE	SHOW TO WHOM AND DATE DELIVERED	¢
	SHOW TO WHOM, DATE, AND ADDRESS OF DELIVERY	¢
	SHOW TO WHOM AND DATE DELIVERED WITH RESTRICTED DELIVERY	¢
	SHOW TO WHOM, DATE AND ADDRESS OF DELIVERY WITH RESTRICTED DELIVERY	¢
TOTAL POSTAGE AND FEES	\$	
POSTMARK OR DATE	1/5/83	

PS Form 3800, Apr. 1976

STATE OF FLORIDA
DEPARTMENT OF ENVIRONMENTAL REGULATION

TWIN TOWERS OFFICE BUILDING
2600 BLAIR STONE ROAD
TALLAHASSEE, FLORIDA 32301-8241



BOB GRAHAM
GOVERNOR
VICTORIA J. TSCHINKEL
SECRETARY

January 4, 1983

CERTIFIED MAIL

Mr. D. J. Nootens, Work Manager
United States Gypsum Company
6825 Evergreen Avenue
Jacksonville, Florida 32208

Dear Mr. Nootens:

RE: Air Construction Permit Application AC 16-64349

The Bureau of Air Quality Management has received your application for a permit to construct a 6500 CFM baghouse at your facility, in Jacksonville, Florida.

The processing fee for your project was not included with the application. In accordance with Section 17-4.05(4)(a)5., FAC, the construction permit for a source having potential emissions of less than 25 tons per year of any single pollutant is \$100.00. Based on this, you need to send a check for \$100.00 to our Tallahassee office.

As soon as the requested fee is received at this office, we will resume processing your application.

If you have any questions on this request, please contact Teresa M. Heron of this office at (904)488-1344.

Sincerely,

C. H. Fancy, P.E.
Deputy Bureau Chief
Bureau of Air Quality
Management

CHF/TH/bjm

DEPARTMENT OF HEALTH, WELFARE
& BIO-ENVIRONMENTAL SERVICES
Bio-Environmental Services Division
Air and Water Pollution Control



DER

DEC 20 1982

BAQM

December 14, 1982 *pa my*

Mr. Clair Fancy, Manager
Central Air Permitting Section
Dept. of Environmental Regulation
Twin Towers Office Building
2600 Blainstone Road
Tallahassee, Florida 32301

Dear Mr. Fancy:

Enclosed is a Construction/Modification Permit Application for the U.S. Gypsum Rock Crusher system. This application is being forwarded to your office for processing, pursuant to the guidelines provided to this Agency. The following comments on the application are provided:

- (1) A \$100 processing fee was not submitted.
- (2) Attached Operation and Maintenance Plan should be included as a permit condition.
- (3) DER should ascertain from applicant requested number of permitted operating hours.

Please contact me if I may be of further assistance.

Very truly yours,

Jerry E. Woosley
Jerry E. Woosley
Assistant Engineer

JEW/vj
Enclosure

cc: Mr. Chris Lawson (U.S. Gypsum)
cc: Mr. Doug Dutton - DER, without enclosure



AC 16-64349



STATE OF FLORIDA
DEPARTMENT OF ENVIRONMENTAL REGULATION
APPLICATION TO OPERATE/CONSTRUCT
AIR POLLUTION SOURCES

SOURCE TYPE: Rock Crusher New¹ Existing¹
APPLICATION TYPE: Construction Operation Modification
COMPANY NAME: United States Gypsum Co. COUNTY: Duval

Identify the specific emission point source(s) addressed in this application (i.e. Lime Kiln No. 4 with Venturi Scrubber; Peeking Unit No. 2, Gas Fired) Rock Crusher Vent

SOURCE LOCATION: Street 6825 Evergreen Ave. City Jacksonville
UTM: East 4 38 900 North 33 61 200
Latitude 30 ° 22 ' 52 "N Longitude 81 ° 38 ' 07 "W

APPLICANT NAME AND TITLE: D. J. Nootens, Works Manager
APPLICANT ADDRESS: 6825 Evergreen Avenue - Jacksonville, Fla. 32208

SECTION I: STATEMENTS BY APPLICANT AND ENGINEER

A. APPLICANT

I am the undersigned owner or authorized representative* of United States Gypsum Co.

I certify that the statements made in this application for a Air Pollution permit are true, correct and complete to the best of my knowledge and belief. Further, I agree to maintain and operate the pollution control source and pollution control facilities in such a manner as to comply with the provision of Chapter 403, Florida Statutes, and all the rules and regulations of the department and revisions thereof. I also understand that a permit, if granted by the department, will be non-transferable and I will promptly notify the department upon sale or legal transfer of the permitted establishment.

*Attach letter of authorization

Signed: [Signature]
D. J. Nootens, Works Manager
Name and Title (Please Type)
Date: 12/2/82 Telephone No. (904) 768-2501

B. PROFESSIONAL ENGINEER REGISTERED IN FLORIDA (where required by Chapter 471, F.S.)

This is to certify that the engineering features of this pollution control project have been designed/examined by me and found to be in conformity with modern engineering principles applicable to the treatment and disposal of pollutants characterized in the permit application. There is reasonable assurance, in my professional judgment, that the pollution control facilities, when properly maintained and operated, will discharge an effluent that complies with all applicable statutes of the State of Florida and the rules and regulations of the department. It is also agreed that the undersigned will furnish, if authorized by the owner, the applicant a set of instructions for the proper maintenance and operation of the pollution control facilities and, if applicable, pollution sources.

(Affix Seal)



Signed: [Signature]
Ragan M. Womack
Name (Please Type)
United States Gypsum Company
Company Name (Please Type)
P.O. Box 3197, Jacksonville, Fla. 32206
Mailing Address (Please Type)
Date: 12/2/82 Telephone No. (904) 768-2501

Florida Registration No. 17417

¹See Section 17-2.02(15) and (22), Florida Administrative Code, (F.A.C.)
DER FORM 17-1.122(16) Page 1 of 10

SECTION II: GENERAL PROJECT INFORMATION

A. Describe the nature and extent of the project. Refer to pollution control equipment, and expected improvements in source performance as a result of installation. State whether the project will result in full compliance. Attach additional sheet if necessary.

This project involves the installation of a dust collector to vent the existing McLanahan roll crusher. All dust will be returned to the process. This installation will provide the plant with additional dust collection capacity and reduce fugitive emissions which are currently vented to the inside of the building.

B. Schedule of project covered in this application (Construction Permit Application Only)

Start of Construction January 1983 Completion of Construction March 1983

C. Costs of pollution control system(s): (Note: Show breakdown of estimated costs only for individual components/units of the project serving pollution control purposes. Information on actual costs shall be furnished with the application for operation permit.)

Costs for the baghouse and associated ducting and installation.
Total cost = \$15,350.

D. Indicate any previous DER permits, orders and notices associated with the emission point, including permit issuance and expiration dates.

None.

E. Is this application associated with or part of a Development of Regional Impact (DRI) pursuant to Chapter 380, Florida Statutes, and Chapter 22F-2, Florida Administrative Code? Yes No

F. Normal equipment operating time: hrs/day 24; days/wk 6-2/3; wks/yr 52; if power plant, hrs/yr _____; if seasonal, describe: Not seasonal, but tied to normal business fluctuations.

G. If this is a new source or major modification, answer the following questions. (Yes or No)

- 1. Is this source in a non-attainment area for a particular pollutant? No.
 - a. If yes, has "offset" been applied? No.
 - b. If yes, has "Lowest Achievable Emission Rate" been applied? No.
 - c. If yes, list non-attainment pollutants. _____
- 2. Does best available control technology (BACT) apply to this source? If yes, see Section VI. No.
- 3. Does the State "Prevention of Significant Deterioration" (PSD) requirements apply to this source? If yes, see Sections VI and VII. No.
- 4. Do "Standards of Performance for New Stationary Sources" (NSPS) apply to this source? No.
- 5. Do "National Emission Standards for Hazardous Air Pollutants" (NESHAP) apply to this source? No.

Attach all supportive information related to any answer of "Yes". Attach any justification for any answer of "No" that might be considered questionable.

SECTION III: AIR POLLUTION SOURCES & CONTROL DEVICES (Other than Incinerators)

A. Raw Materials and Chemicals Used in your Process, if applicable:

Description	Contaminants		Utilization Rate - lbs/hr	Relate to Flow Diagram
	Type	% Wt		
CaSO ₄ ·2H ₂ O (Gypsum)	Particulate			See flow sheet.

B. Process Rate, if applicable: (See Section V, Item 1)

1. Total Process Input Rate (lbs/hr): 200,000

2. Product Weight (lbs/hr): 200,000

C. Airborne Contaminants Emitted: **Total emissions - (See addendum for calculations.)**

Name of Contaminant	Emission ¹		Allowed Emission ² Rate per Ch. 17-2, F.A.C.	Allowable ³ Emission lbs/hr	Potential Emission ⁴		Relate to Flow Diagram
	Maximum lbs/hr	Actual T/yr			lbs/hr	T/yr	
Particulate	1.11	3.46			1110	3463.2	See addendum

D. Control Devices: (See Section V, Item 4)

Name and Type (Model & Serial No.)	Contaminant	Efficiency	Range of Particles ⁵ Size Collected (in microns)	Basis for Efficiency (Sec. V, It ⁵)
BH-7 Baghouse	Gypsum	99.9		Design
Flex-Kleen, 6000 CFM				

¹See Section V, Item 2.

²Reference applicable emission standards and units (e.g., Section 17-2.05(6) Table II, E. (1), F.A.C. - 0.1 pounds per million BTU heat input)

³Calculated from operating rate and applicable standard

⁴Emission, if source operated without control (See Section V, Item 3)

⁵If Applicable

E. Fuels

Type (Be Specific)	Consumption*		Maximum Heat Input (MMBTU/hr)
	avg/hr	max./hr	
N/A			

*Units Natural Gas, MMCF/hr; Fuel Oils, barrels/hr; Coal, lbs/hr

Fuel Analysis:

Percent Sulfur: _____ Percent Ash: _____

Density: _____ lbs/gal Typical Percent Nitrogen: _____

Heat Capacity: _____ BTU/lb _____ BTU/gal

Other Fuel Contaminants (which may cause air pollution): _____

F. If applicable, indicate the percent of fuel used for space heating. Annual Average N/A Maximum _____

G. Indicate liquid or solid wastes generated and method of disposal.

All dust returned to process.

H. Emission Stack Geometry and Flow Characteristics (Provide data for each stack):

Stack Height: 57 ft. Stack Diameter: 1.33 X 1.67 ft.

Gas Flow Rate: 6000 ACFM Gas Exit Temperature: 110 °F.

Water Vapor Content: 5.0 % Velocity: 45 FPS

SECTION IV: INCINERATOR INFORMATION

N/A

Type of Waste	Type O (Plastics)	Type I (Rubbish)	Type II (Refuse)	Type III (Garbage)	Type IV (Pathological)	Type V (Liq & Gas By-prod.)	Type VI (Solid By-prod.)
Lbs/hr Incinerated							

Description of Waste _____

Total Weight Incinerated (lbs/hr) _____ Design Capacity (lbs/hr) _____

Approximate Number of Hours of Operation per day _____ days/week _____

Manufacturer _____

Date Constructed _____ Model No. _____

	Volume (ft) ³	Heat Release (BTU/hr)	Fuel		Temperature (°F)
			Type	BTU/hr	
Primary Chamber					
Secondary Chamber					

Stack Height: _____ ft. Stack Diameter _____ Stack Temp. _____

Gas Flow Rate: _____ ACFM _____ DSCFM* Velocity _____ FPS

*If 50 or more tons per day design capacity, submit the emissions rate in grains per standard cubic foot dry gas corrected to 50% excess air.

Type of pollution control device: Cyclone Wet Scrubber Afterburner Other (specify) _____

Brief description of operating characteristics of control devices: _____

Ultimate disposal of any effluent other than that emitted from the stack (scrubber water, ash, etc.):

SECTION V: SUPPLEMENTAL REQUIREMENTS

Please provide the following supplements where required for this application.

1. Total process input rate and product weight – show derivation.
2. To a construction application, attach basis of emission estimate (e.g., design calculations, design drawings, pertinent manufacturer's test data, etc.) and attach proposed methods (e.g., FR Part 60 Methods 1, 2, 3, 4, 5) to show proof of compliance with applicable standards. To an operation application, attach test results or methods used to show proof of compliance. Information provided when applying for an operation permit from a construction permit shall be indicative of the time at which the test was made.
3. Attach basis of potential discharge (e.g., emission factor, that is, AP42 test).
4. With construction permit application, include design details for all air pollution control systems (e.g., for baghouse include cloth to air ratio; for scrubber include cross-section sketch, etc.).
5. With construction permit application, attach derivation of control device(s) efficiency. Include test or design data. Items 2, 3, and 5 should be consistent: actual emissions = potential (1-efficiency).
6. An 8½" x 11" flow diagram which will, without revealing trade secrets, identify the individual operations and/or processes. Indicate where raw materials enter, where solid and liquid waste exit, where gaseous emissions and/or airborne particles are evolved and where finished products are obtained.
7. An 8½" x 11" plot plan showing the location of the establishment, and points of airborne emissions, in relation to the surrounding area, residences and other permanent structures and roadways (Example: Copy of relevant portion of USGS topographic map).
8. An 8½" x 11" plot plan of facility showing the location of manufacturing processes and outlets for airborne emissions. Relate all flows to the flow diagram.

ADDENDUM TO PERMIT APPLICATION

FOR

AIR POLLUTION SOURCE

$$\text{Process weight: } 100 \frac{\text{Tons}}{\text{Hr.}} * 2000 \frac{\text{Lbs.}}{\text{Ton}} = 200,000 \text{ Lbs./Hr.}$$

Product weight: Same as above.

Particulates from Baghouse:

$$6500 \frac{\text{Ft.}^3}{\text{Min.}} * 60 \frac{\text{Min.}}{\text{Hr.}} * 0.02 \frac{\text{Grains}}{\text{Ft.}^3} * \frac{1 \text{ Lb.}}{7000 \text{ Grains}} = 1.11 \text{ Lbs./Hr.}$$

$$1.11 \frac{\text{Lbs.}}{\text{Hr.}} * 6240 \frac{\text{Hrs.}}{\text{Yr.}} * \frac{1 \text{ Ton}}{7000 \text{ Lbs.}} = 3.46 \text{ Tons/Yr.}$$

Potential Emissions:

$$1.11 \frac{\text{Lbs.}}{\text{Hr.}} * \frac{100\%}{(100-99.9)\%} = 1110 \text{ Lbs./Hr.}$$

$$1110 \frac{\text{Lbs.}}{\text{Hr.}} * 6240 \frac{\text{Hrs.}}{\text{Yr.}} * \frac{1 \text{ Ton}}{2000 \text{ Lbs.}} = 3463.2 \text{ Tons/Yr.}$$

DETAILS FOR AIR POLLUTION CONTROL

- . 6500 CFM
- . 1032 Sq.Ft. of filter cloth area
- . Air-to-cloth ratio of 6.3:1
- . 12-Ga. carbon steel housing designed to withstand 17" w.g. positive or negative pressure
- . Schedule 40 internal piping
- . 16-oz. polypropylene bags
- . Direct reading pressure differential gauge
- . Air pressure gauge
- . Blower fan in carbon steel construction able to deliver 6500 ACFM at 70°F and 12" S.P. when running at 2000 RPM and 11 BHP

OPERATION & MAINTENANCE PLAN

The purpose of this operation and maintenance plan is to insure the proper operation of emission control equipment. The following inspection and maintenance schedules must be strictly adhered to:

- 1) Monthly inspection by operating department of all performance parameters and equipment (bags, clamps, gaskets, etc.) associated with control equipment.
- 2) Weekly visual inspection of differential pressures and pulse air pressures where applicable. This to be the responsibility of the operating department.
- 3) Quarterly visible emission tests (6 min.) to insure proper operation.

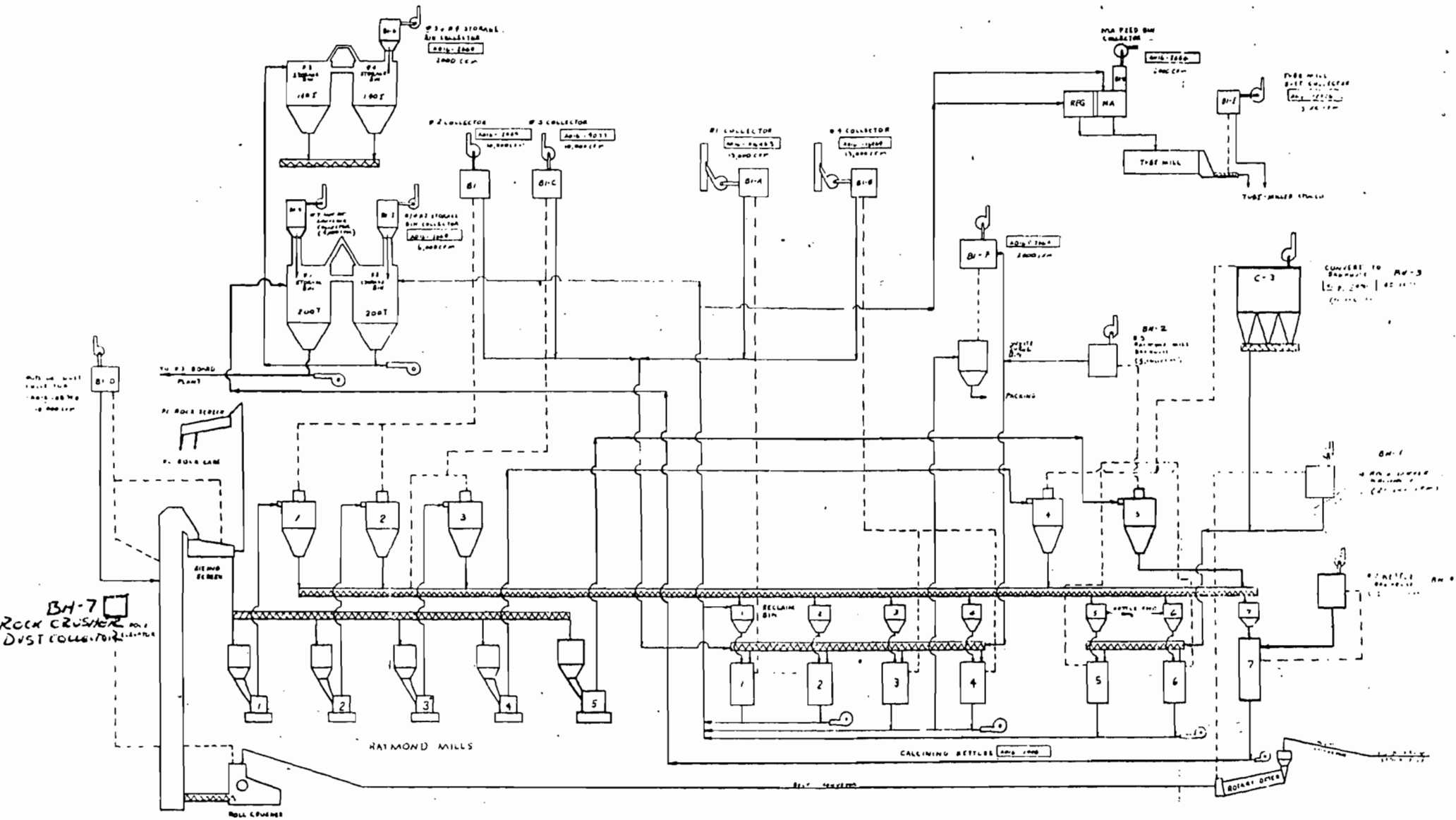

<p>DESIGNED BY: H. F. WILLIAMS</p> <p>DRAWN BY: S. W. WILKS</p> <p>APPROVED BY:</p> <p>DATE: 1/20/40</p>	<p>UNITED STATES GYPSUM CO. CHICAGO, ILL.</p> <p>5-FES REFINING MILL, ILLINOIS, U.S.A.</p> <p>MILL FLOW DIAGRAM 1 DETAIL</p>	<p>REV. ○</p>
--	--	---------------