

Central Florida Testing Laboratories, Inc.

Clearwater, Florida

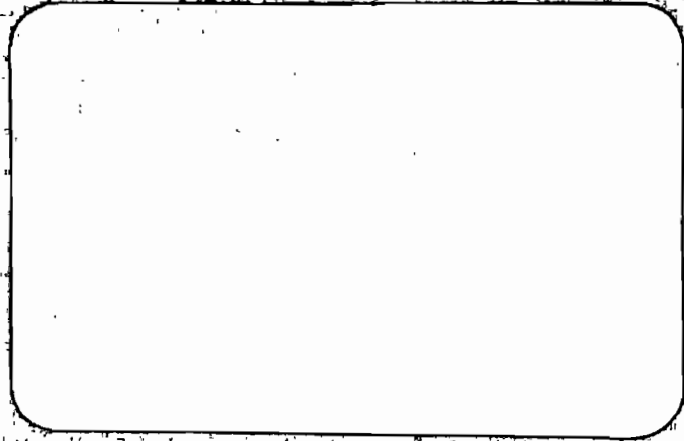

*Testing Development and Research
Engineering Consultants*

Best Available Copy

RECEIVED

FEB 26 1999

BUREAU OF
AIR REGULATION

White Rock Quarries

Portable - Bohringer Model RC10,
Reclaimed Asphalt and Concrete
Crushing Unit

FDEP Construction Permit Application
February - 1999



Department of Environmental Protection

DIVISION OF AIR RESOURCES MANAGEMENT

APPLICATION FOR AIR PERMIT - LONG FORM

See Instructions for Form No. 62-210.900 (1)

I. APPLICATION INFORMATION

This section of the Application for Air Permit form identifies the facility and provides general information on the scope and purpose of this application. This section also includes information on the owner or authorized representative of the facility (or the responsible official in the case of a Title V source) and the necessary statements for the applicant and professional engineer, where required, to sign and date for formal submittal of the Application for Air Permit to the Department. If the application form is submitted to the Department using ELSA, this section of the Application for Air Permit must also be submitted in hard-copy.

Identification of Facility Addressed in This Application

Enter the name of the corporation, business, governmental entity, or individual that has ownership or control of the facility; the facility site name, if any; and the facility's physical location. If known, also enter the facility identification number.

| | |
|---|--|
| 1. Facility Owner/Company Name: Mr. Jim Hurley, Executive Vice President - Quarries White Rock Quarries | |
| 2. Site Name: White Rock Quarries | |
| 3. Facility Identification Number: <input checked="" type="checkbox"/> Unknown | |
| 4. Facility Location: (base location of facility) Street Address or Other Locator: 1401 Reed Canal Road City: Port Orange County: Volusia Zip Code: 32119 | |
| 5. Relocatable Facility? <input checked="" type="checkbox"/> Yes <input type="checkbox"/> No | 6. Existing Permitted Facility? <input type="checkbox"/> Yes <input checked="" type="checkbox"/> No |

Application Processing Information (DEP Use)

| | |
|------------------------------------|--|
| 1. Date of Receipt of Application: | |
| 2. Permit Number: | |
| 3. PSD Number (if applicable): | |
| 4. Siting Number (if applicable): | |

Owner/Authorized Representative or Responsible Official

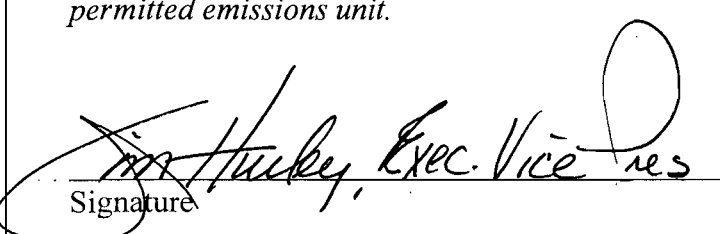
| |
|--|
| 1. Name and Title of Owner/Authorized Representative or Responsible Official: Mr. Jim Hurley, Executive Vice President – Quarries |
| 2. Owner/Authorized Representative or Responsible Official Mailing Address: Organization/Firm: White Rock Quarries Street Address: Post Office Box 15065 City: West Palm Beach State: Florida Zip Code: 33416 |
| 3. Owner/Authorized Representative or Responsible Official Telephone Numbers: Telephone: (561) 793-2102 Fax: (561) 798-3778 |
| 4. Owner/Authorized Representative or Responsible Official Statement: <i>I, the undersigned, am the owner or authorized representative* of the non-Title V source addressed in this Application for Air Permit or the responsible official, as defined in Rule 62-210.200, F.A.C., of the Title V source addressed in this application, whichever is applicable. I hereby certify, based on information and belief formed after reasonable inquiry, that the statements made in this application are true, accurate and complete and that, to the best of my knowledge, any estimates of emissions reported in this application are based upon reasonable techniques for calculating emissions. The air pollutant emissions units and air pollution control equipment described in this application will be operated and maintained so as to comply with all applicable standards for control of air pollutant emissions found in the statutes of the State of Florida and rules of the Department of Environmental Protection and revisions thereof. I understand that a permit, if granted by the Department, cannot be transferred without authorization from the Department, and I will promptly notify the Department upon sale or legal transfer of any permitted emissions unit.</i>  Signature _____ Date <u>2/22/99</u> |

* Attach letter of authorization if not currently on file.

Scope of Application

This Application for Air Permit addresses the following emissions unit(s) at the facility. An Emissions Unit Information Section (a Section III of the form) must be included for each emissions unit listed.

| Emissions Unit ID | Description of Emissions Unit | Permit Type |
|-------------------|---|-------------|
| 001 | Bohringer, Model RC10 – raw material receiving hopper / vibrating grizzly feeder system used to feed uncrushed material to crusher. | AC1E |
| 002 | Bohringer, Model RC10 – Under Crusher Discharge Pan / Discharge Belt – where material exits crushing unit to conveyor system | AC1E |
| 003 | Drop Point from Crusher Discharge Belt to Pre-Screener Conveyor Belt | AC1E |
| 004 | Drop point from Pre-Screener Screener Belt to Vibrating Screener Deck | AC1E |
| 005 | Drop point from Vibrating Screener to Screened Material Discharge Belt | AC1E |
| 006 | Drop point Screened Material Discharge Belt to Radial Stacker Belt No.1 | AC1E |
| 007 | Drop Radial Stacker Belt No.1 to Radial Stacker Belt No.2 | AC1E |
| 008 | Drop from Radial Stacker Belt No.1 or No.2 to stockpile | AC1E |
| 009 | Caterpillar Inc. – 400 KVA, 320 kW generator set, fired on No.2 virgin diesel fuel with a sulfur limit of 0.5% by weight. | AC1E |
| | | |
| | | |
| | | |
| | | |
| | | |
| | | |
| | | |
| | | |
| | | |
| | | |

Purpose of Application and Category

Check one (except as otherwise indicated):

Category I: All Air Operation Permit Applications Subject to Processing Under Chapter 62-213, F.A.C.

This Application for Air Permit is submitted to obtain:

- Initial air operation permit under Chapter 62-213, F.A.C., for an existing facility which is classified as a Title V source.
- Initial air operation permit under Chapter 62-213, F.A.C., for a facility which, upon start up of one or more newly constructed or modified emissions units addressed in this application, would become classified as a Title V source.

Current construction permit number: _____

- Air operation permit renewal under Chapter 62-213, F.A.C., for a Title V source.

Operation permit to be renewed: _____

- Air operation permit revision for a Title V source to address one or more newly constructed or modified emissions units addressed in this application.

Current construction permit number: _____

Operation permit to be revised: _____

- Air operation permit revision or administrative correction for a Title V source to address one or more proposed new or modified emissions units and to be processed concurrently with the air construction permit application. Also check Category III.

Operation permit to be revised/corrected: _____

- Air operation permit revision for a Title V source for reasons other than construction or modification of an emissions unit. Give reason for the revision; e.g., to comply with a new applicable requirement or to request approval of an "Early Reductions" proposal.

Operation permit to be revised: _____

Reason for revision: _____

Category II: All Air Operation Permit Applications Subject to Processing Under Rule 62-210.300(2)(b), F.A.C.

This Application for Air Permit is submitted to obtain:

- Initial air operation permit under Rule 62-210.300(2)(b), F.A.C., for an existing facility seeking classification as a synthetic non-Title V source.

Current operation/construction permit number(s): _____

- Renewal air operation permit under Rule 62-210.300(2)(b), F.A.C., for a synthetic non-Title V source.

Operation permit to be renewed: _____

- Air operation permit revision for a synthetic non-Title V source. Give reason for revision; e.g., to address one or more newly constructed or modified emissions units.

Operation permit to be revised: _____

Reason for revision: _____

Category III: All Air Construction Permit Applications for All Facilities and Emissions Units

This Application for Air Permit is submitted to obtain:

- Air construction permit to construct or modify one or more emissions units within a facility (including any facility classified as a Title V source).

Current operation permit number(s), if any: _____

- Air construction permit to make federally enforceable an assumed restriction on the potential emissions of one or more existing, permitted emissions units.

Current operation permit number(s): _____

- Air construction permit for one or more existing, but unpermitted, emissions units.

Application Processing Fee

Check one:

Attached - Amount: \$ **2000.⁰⁰** [] Not Applicable.

(* \$1000.00 for Crusher Emissions, \$1000.00 for Generator Emissions – both less than 25 tpy but more than 5 tpy)

Construction/Modification Information

1. Description of Proposed Project or Alterations:

This project consists of a “statewide” construction permit application for a Portable Bohringer Manufacturing Company, Inc. – Model RC10, Enclosed Crusher – Crushing, Screening and Aggregate Processing Plant recently purchased and being refurbished by White Rock Quarries. This is a portable crushing unit and will be moved from site to site statewide, as needed, within the counties mentioned below to crush and process reclaimed asphalt and concrete materials. The base or main location of this crushing unit will be at an asphalt plant location in Port Orange, Volusia County, Florida. Other locations have not been determined as of yet, but this crusher would like to operate in the counties listed in this permit application. Any emissions that might be generated at various potential emission points throughout the crushing and conveying system will controlled by self-fabricated water spray bar and spray head systems located at potential fugitive emission points where deemed necessary throughout the reclaimed crushing and processing system.

All stockpiles and roadways throughout different sites are the responsibility of the site that this company will be crushing for.

Counties in which this portable Aggregate Crushing and Processing Unit would like to operate: Collier, Lee, Charlotte, Sarasota, Hillsborough, Pasco, Hernando, Pinellas, Highlands, Osceola, Seminole, Orange, Brevard, Manatee, St. Johns, Duval, Volusia, Polk, Sumter, Marion, Citrus, Palm Beach, Broward, Dade and St. Lucie Counties.

This facility is a natural non-Title V facility and as in the past will comply with all applicable FDEP air pollution rules and regulations.

2. Projected or Actual Date of Commencement of Construction:
ASAP

3. Projected Date of Completion of Construction:
JANUARY-2000

Professional Engineer Certification

1. Professional Engineer Name: **Mr. George C. Sinn, Jr., P.E.**
Registration Number: **16911**

2. Professional Engineer Mailing Address:
Organization/Firm: **Central Florida Testing Laboratories, Inc**
Street Address: **12625 – 40th Street North**
City: **Clearwater** State: **Florida** Zip Code: **33762**

3. Professional Engineer Telephone Numbers:
Telephone: **(727) 572-9797** Fax: **(727) 299-0023**

4. Professional Engineer Statement:

I, the undersigned, hereby certify, except as particularly noted herein, that:*

(1) To the best of my knowledge, there is reasonable assurance that the air pollutant emissions unit(s) and the air pollution control equipment described in this Application for Air Permit, when properly operated and maintained, will comply with all applicable standards for control of air pollutant emissions found in the Florida Statutes and rules of the Department of Environmental Protection; and

(2) To the best of my knowledge, any emission estimates reported or relied on in this application are true, accurate, and complete and are either based upon reasonable techniques available for calculating emissions or, for emission estimates of hazardous air pollutants not regulated for an emissions unit addressed in this application, based solely upon the materials, information and calculations submitted with this application.

If the purpose of this application is to obtain a Title V source air operation permit (check here [] if so), I further certify that each emissions unit described in this Application for Air Permit, when properly operated and maintained, will comply with the applicable requirements identified in this application to which the unit is subject, except those emissions units for which a compliance schedule is submitted with this application.

If the purpose of this application is to obtain an air construction permit for one or more proposed new or modified emissions units (check here [X] if so), I further certify that the engineering features of each such emissions unit described in this application have been designed or examined by me or individuals under my direct supervision and found to be in conformity with sound engineering principles applicable to the control of emissions of the air pollutants characterized in this application.

If the purpose of this application is to obtain an initial air operation permit or operation permit revision for one or more newly constructed or modified emissions units (check here [] if so), I further certify that, with the exception of any changes detailed as part of this application, each such emissions unit has been constructed or modified in substantial accordance with the information given in the corresponding application for air construction permit, and with all provisions contained in such permit.

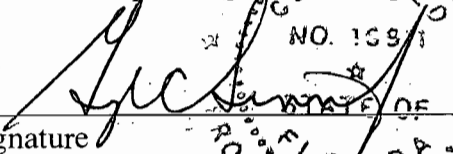
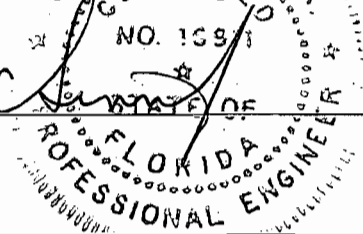
Signature  Date 2-15-99
(seal) 

- Attach any exception to certification statement.
- ** *With the exception of any efficiency or production guarantees made by manufacturer.*

Application Contact

| |
|---|
| 1. Name and Title of Application Contact: Mr. Bernard A. Ball, Jr., Environmental Specialist |
| 2. Application Contact Mailing Address: Organization/Firm: Central Florida Testing Laboratories, Inc Street Address: 12625 – 40th Street North City: Clearwater State: Florida Zip Code: 33762 |
| 3. Application Contact Telephone Numbers: Telephone: (727) 572-9797 Fax: (727) 299-0023 |

Application Comment

This project consists of a “statewide” construction permit application for a Portable Bohringer Manufacturing Company, Inc. – Model RC10, Enclosed Crusher – Crushing, Screening and Aggregate Processing Plant recently purchased and being refurbished by White Rock Quarries. This is a portable crushing unit and will be moved from site to site statewide, as needed, within the counties mentioned below to crush and process reclaimed asphalt and concrete materials. The base or main location of this crushing unit will be at an asphalt plant location in Port Orange, Volusia County, Florida. Other locations have not been determined as of yet, but this crusher would like to operate in the counties listed below. Any emissions that might be generated at various potential emission points throughout the crushing and conveying system will be controlled by self-fabricated water spray bar and spray head systems located at potential fugitive emission points where deemed necessary throughout the reclaimed crushing and processing system.

All stockpiles and roadways throughout different sites are the responsibility of the site that this company will be crushing for.

Counties in which this portable Aggregate Crushing and Processing Unit would like to operate: Collier, Lee, Charlotte, Sarasota, Hillsborough, Pasco, Hernando, Pinellas, Highlands, Osceola, Seminole, Orange, Brevard, Manatee, St. Johns, Duval, Volusia, Polk, Sumter, Marion, Citrus, Palm Beach, Broward, Dade and St. Lucie Counties.

This facility is a natural non-Title V facility and as in the past will comply with all applicable FDEP air pollution rules and regulations.

II. FACILITY INFORMATION

A. GENERAL FACILITY INFORMATION

Facility Location and Type

| | | | |
|--|--|---|---|
| 1. Facility UTM Coordinates: <i>(for base/main location of crushing unit only, others not determined as of yet.)</i> Zone: 17 East (km): 499.7 North (km): 3225.5 | | | |
| 2. Facility Latitude/Longitude: <i>(for base/main location of crushing unit only, others not determined as of yet.)</i> Latitude (DD/MM/SS): 29° 09' 37" Longitude (DD/MM/SS): 81° 00' 11" | | | |
| 3. Governmental Facility Code: <p style="text-align: center;">0</p> | 4. Facility Status Code: <p style="text-align: center;">Construction</p> | 5. Facility Major Group SIC Code: <p style="text-align: center;">14</p> | 6. Facility SIC(s): <p style="text-align: center;">1422</p> |
| 7. Facility Comment (limit to 500 characters): This project consists of a "statewide" construction permit application for a Portable Bohringer Manufacturing Company, Inc. – Model RC10, Enclosed Crusher – Crushing, Screening and Aggregate Processing Plant recently purchased and being refurbished by White Rock Quarries. This is a portable crushing unit and will be moved from site to site statewide, as needed, within the counties mentioned below to crush and process reclaimed asphalt and concrete materials. The base or main location of this crushing unit will be at an asphalt plant location in Port Orange, Volusia County, Florida. Other locations have not been determined as of yet, but this crusher would like to operate in the counties listed in previous sections. Any emissions that might be generated at various potential emission points throughout the crushing and conveying system will controlled by self-fabricated water spray bar and spray head systems located at potential fugitive emission points where deemed necessary throughout the reclaimed crushing and processing system. This facility is a natural non-Title V facility and as in the past will comply with all applicable FDEP air pollution rules and regulations. | | | |

Facility Contact

| | |
|---|--|
| 1. Name and Title of Facility Contact: <p style="text-align: center;">Mr. Jerry Kinkead, Plant Operations Supervisor</p> | |
| 2. Facility Contact Mailing Address: Organization/Firm: White Rock Quarries Street Address: P.O. Box 15065 City: West Palm Beach State: Florida Zip Code: 33416 | |
| 3. Facility Contact Telephone Numbers: Telephone: (561) 793-2102 Fax: (561) 798-3778 | |

Facility Regulatory Classifications

| |
|--|
| 1. Small Business Stationary Source? <input type="checkbox"/> Yes <input type="checkbox"/> No <input checked="" type="checkbox"/> Unknown |
| 2. Title V Source? <input type="checkbox"/> Yes <input checked="" type="checkbox"/> No |
| 3. Synthetic Non-Title V Source? <input type="checkbox"/> Yes <input checked="" type="checkbox"/> No |
| 4. Major Source of Pollutants Other than Hazardous Air Pollutants (HAPs)? <input type="checkbox"/> Yes <input checked="" type="checkbox"/> No |
| 5. Synthetic Minor Source of Pollutants Other than HAPs? <input checked="" type="checkbox"/> Yes <input type="checkbox"/> No |
| 6. Major Source of Hazardous Air Pollutants (HAPs)? <input type="checkbox"/> Yes <input checked="" type="checkbox"/> No |
| 7. Synthetic Minor Source of HAPs? <input type="checkbox"/> Yes <input checked="" type="checkbox"/> No |
| 8. One or More Emissions Units Subject to NSPS? <input checked="" type="checkbox"/> Yes <input type="checkbox"/> No |
| 9. One or More Emission Units Subject to NESHAP? <input type="checkbox"/> Yes <input checked="" type="checkbox"/> No |
| 10. Title V Source by EPA Designation? <input type="checkbox"/> Yes <input checked="" type="checkbox"/> No |
| 11. Facility Regulatory Classifications Comment (limit to 200 characters): Natural Non Title V Source |

B. FACILITY REGULATIONS

Rule Applicability Analysis (Required for Category II applications and Category III applications involving non Title-V sources. See Instructions.)

This facility will be subject to 40 CFR, Part 60, subpart 000.

List of Applicable Regulations (Required for Category I applications and Category III applications involving Title-V sources. See Instructions.)

| | |
|---|--|
| 62-212.200(56) FAC | |
| 62-296.800 FAC | |
| 40 CFR 60, Subpart 000 | |
| 62-296.310(2) FAC | |
| 62-297 FAC | |
| 62-297.340 FAC | |
| 62-210.350 FAC | |
| Chapter 84-446, Section 3(12) FS | |
| 62-296.320 FAC | |
| 62-296.310 (3) FAC | |
| 40 CFR 60.11 (d) | |
| 62-4 FAC | |
| 62-210 | |
| | |
| | |
| | |
| | |
| | |
| | |

C. FACILITY POLLUTANTS

Facility Pollutant Information

| 1. Pollutant Emitted | 2. Pollutant Classification |
|----------------------|-----------------------------|
| PM10 | SM |
| TSP | SM |
| SO2 | SM |
| NOX | SM |
| CO | SM |
| TOC | SM |
| | |
| | |
| | |
| | |
| | |
| | |
| | |
| | |
| | |
| | |
| | |
| | |

D. FACILITY POLLUTANT DETAIL INFORMATION

Facility Pollutant Detail Information: Pollutant 1 of 6

| |
|--|
| 1. Pollutant Emitted: PM10 |
| 2. Requested Emissions Cap: (#1) < 10% opacity from transfer points, belt conveyors, storage piles and vehicular traffic – (#2) <1 5% Opacity from crusher, <10% from feeder, discharger and screener (#3) < 20% opacity from Generator Exhaust – General Particulate Limiting Standards (62-296.31(2)(a)). |
| 3. Basis for Emissions Cap Code: Rule |
| 4. Facility Pollutant Comment (limit to 400 characters): Facility is subject to opacity limitations only. |

Facility Pollutant Detail Information: Pollutant 2 of 6

| |
|---|
| 1. Pollutant Emitted: TSP |
| 2. Requested Emissions Cap: Visible emissions limitations listed above. |
| 3. Basis for Emissions Cap Code: Rule |
| 4. Facility Pollutant Comment (limit to 400 characters): Facility is subject to opacity limitations only. |

Facility Pollutant Detail Information: Pollutant 3 of 6

| |
|--|
| 1. Pollutant Emitted: NOx (Gen-Set) |
| 2. Requested Emissions Cap: < 20% Opacity |
| 3. Basis for Emissions Cap Code: FAC 62-296.310 |
| 4. Facility Pollutant Comment (limit to 400 characters): Generator subject to opacity limits only. |

Facility Pollutant Detail Information: Pollutant 4 of 6

| |
|--|
| 1. Pollutant Emitted: CO (Gen-Set) |
| 2. Requested Emissions Cap: < 20% Opacity |
| 3. Basis for Emissions Cap Code: Fac 62-396.310 |
| 4. Facility Pollutant Comment (limit to 400 characters): Generator subject to opacity limits only. |

Facility Pollutant Detail Information: Pollutant 5 of 6

| |
|--|
| 1. Pollutant Emitted: SO2 |
| 2. Requested Emissions Cap: < 20% Opacity |
| 3. Basis for Emissions Cap Code: FAC 62-296.310 |
| 4. Facility Pollutant Comment (limit to 400 characters): Generator Subject to opacity limits only. |

Facility Pollutant Detail Information: Pollutant 6 of 6

| |
|--|
| 1. Pollutant Emitted: Total TOC (Gen-Set) |
| 2. Requested Emissions Cap: < 20% opacity |
| 3. Basis for Emissions Cap Code: FAC 62-396.310 |
| 4. Facility Pollutant Comment (limit to 400 characters): Generator subject to opacity limits only. |

E. FACILITY SUPPLEMENTAL INFORMATION

Supplemental Requirements for All Applications

| |
|--|
| 1. Area Map Showing Facility Location: <input checked="" type="checkbox"/> Attached, Document ID: <u> I </u> [] Not Applicable [] Waiver Requested |
| 2. Facility Plot Plan: <input checked="" type="checkbox"/> Attached, Document ID: <u> II </u> [] Not Applicable [] Waiver Requested *** Typical facility plot plan enclosed, as typically set up at crushing sites. |
| 3. Process Flow Diagram(s): <input checked="" type="checkbox"/> Attached, Document ID: <u> III </u> [] Not Applicable [] Waiver Requested |
| 4. Precautions to Prevent Emissions of Unconfined Particulate Matter: [] Attached, Document ID: _____ [] Not Applicable <input checked="" type="checkbox"/> Waiver Requested ** Fugitive emissions from vehicular traffic and stockpiles will be site owner's responsibility. |
| 5. Fugitive Emissions Identification: [] Attached, Document ID: _____ <input checked="" type="checkbox"/> Not Applicable [] Waiver Requested |
| 6. Supplemental Information for Construction Permit Application: <input checked="" type="checkbox"/> Attached, Document ID: _____ [] Not Applicable |

Additional Supplemental Requirements for Category I Applications Only

| |
|--|
| 7. List of Proposed Exempt Activities: [] Attached, Document ID: _____ <input checked="" type="checkbox"/> Not Applicable |
| 8. List of Equipment/Activities Regulated under Title VI: [] Attached, Document ID: _____ [] Equipment/Activities On site but Not Required to be Individually Listed <input checked="" type="checkbox"/> Not Applicable |
| 9. Alternative Methods of Operation: [] Attached, Document ID: _____ <input checked="" type="checkbox"/> Not Applicable |
| 10. Alternative Modes of Operation (Emissions Trading): [] Attached, Document ID: _____ <input checked="" type="checkbox"/> Not Applicable |

| |
|---|
| <p>11. Identification of Additional Applicable Requirements: <input type="checkbox"/> Attached, Document ID: _____ <input checked="" type="checkbox"/> Not Applicable</p> |
| <p>12. Compliance Assurance Monitoring Plan: <input type="checkbox"/> Attached, Document ID: _____ <input checked="" type="checkbox"/> Not Applicable</p> |
| <p>13. Risk Management Plan Verification:</p> <p><input type="checkbox"/> Plan Submitted to Implementing Agency - Verification Attached, Document ID: _____</p> <p><input type="checkbox"/> Plan to be Submitted to Implementing Agency by Required Date</p> <p><input checked="" type="checkbox"/> Not Applicable</p> |
| <p>14. Compliance Report and Plan: <input type="checkbox"/> Attached, Document ID: _____ <input checked="" type="checkbox"/> Not Applicable</p> |
| <p>15. Compliance Certification (Hard-copy Required): <input type="checkbox"/> Attached, Document ID: _____ <input checked="" type="checkbox"/> Not Applicable</p> |

EMISSIONS ID. NO. 001

RECEIVING HOPPER / VIBRATING FEEDER

III. EMISSIONS UNIT INFORMATION

A separate Emissions Unit Information Section (including subsections A through L as required) must be completed for each emissions unit addressed in this Application for Air Permit. If submitting the application form in hard copy, indicate, in the space provided at the top of each page, the number of this Emissions Unit Information Section and the total number of Emissions Unit Information Sections submitted as part of this application. Some of the subsections comprising the Emissions Unit Information Section of the form are intended for regulated emissions units only. Others are intended for both regulated and unregulated emissions units. Each subsection is appropriately marked.

A. TYPE OF EMISSIONS UNIT (Regulated and Unregulated Emissions Units)

Type of Emissions Unit Addressed in This Section

1. Regulated or Unregulated Emissions Unit? Check one:

The emissions unit addressed in this Emissions Unit Information Section is a regulated emissions unit.

The emissions unit addressed in this Emissions Unit Information Section is an unregulated emissions unit.

2. Single Process, Group of Processes, or Fugitive Only? Check one:

This Emissions Unit Information Section addresses, as a single emissions unit, a single process or production unit, or activity, which produces one or more air pollutants and which has at least one definable emission point (stack or vent).

This Emissions Unit Information Section addresses, as a single emissions unit, a group of process or production units and activities which has at least one definable emission point (stack or vent) but may also produce fugitive emissions.

This Emissions Unit Information Section addresses, as a single emissions unit, one or more process or production units and activities which produce fugitive emissions only.

**B. GENERAL EMISSIONS UNIT INFORMATION
(Regulated and Unregulated Emissions Units)**

Emissions Unit Description and Status

| | | |
|--|--------------------------------------|--|
| 1. Description of Emissions Unit Addressed in This Section (limit to 60 characters): Bohringer Machinery Company, Inc. - raw material receiving hopper / vibrating grizzly feeder system used to feed uncrushed material to crushing unit. | | |
| 2. Emissions Unit Identification Number: [] No Corresponding ID [] Unknown | | |
| 3. Emissions Unit Status Code: Construction | 4. Acid Rain Unit? [] Yes [X] No | 5. Emissions Unit Major Group SIC Code: 14 |
| 6. Emissions Unit Comment (limit to 500 characters): | | |

Emissions Unit Control Equipment

A.

| |
|--|
| 1. Description (limit to 200 characters): The fugitive emissions generated by dumping of uncrushed material into raw material receiving hopper and vibration of material by grizzly feeder into crusher are controlled by wetting of material in stockpiles as needed to dampen the material to control any emissions generated in the grizzly feeder and crushing unit. |
| 2. Control Device or Method Code: <p align="center">061, 099</p> |

B.

| |
|---|
| 1. Description (limit to 200 characters): |
| |
| 2. Control Device or Method Code: |
| |

C.

| |
|---|
| 1. Description (limit to 200 characters): |
| |
| 2. Control Device or Method Code: |
| |

**C. EMISSIONS UNIT DETAIL INFORMATION
(Regulated Emissions Units Only)**

Emissions Unit Details

| |
|---|
| 1. Initial Startup Date: ASAP |
| 2. Long-term Reserve Shutdown Date: NOT APPLICABLE |
| 3. Package Unit: Raw Material Receiving Hopper / Vibrating Grizzly Feeder System Manufacturer: Bohringer Machinery Company, Inc. Model No: RC10 |
| 4. Generator Nameplate Rating: MW |
| 5. Incinerator Information: <div style="text-align: right; margin-right: 100px;">Dwell Temperature: °F</div> <div style="text-align: right; margin-right: 100px;">Dwell Time: seconds</div> <div style="text-align: right; margin-right: 100px;">Incinerator Afterburner Temperature: °F</div> |

Emissions Unit Operating Capacity

| | |
|--|-------------------------------------|
| 1. Maximum Heat Input Rate: NONE | mmBtu/hr |
| 2. Maximum Incineration Rate: NA | lb/hr tons/day |
| 3. Maximum Process or Throughput Rate: 250 ton/hr as raw (uncrushed) reclaimed asphalt or concrete | |
| 4. Maximum Production Rate: 250 ton/hr as reclaimed crushed concrete or asphalt material. | |
| 5. Operating Capacity Comment (limit to 200 characters): <p>Dampened, uncrushed reclaimed concrete or asphalt material is fed into the material receiving hopper and grizzly feeder of the plant where any fugitive emissions generated are controlled by water spray heads mounted in the receiving hopper which sprays the material before it enters the grizzly feeder and crusher.</p> | |

Emissions Unit Operating Schedule

| | | |
|---------------------------------------|-----------------|--|
| Requested Maximum Operating Schedule: | | |
| 10 hours/day | 6 days/week | |
| 52 weeks/year | 3120 hours/year | |

**D. EMISSIONS UNIT REGULATIONS
(Regulated Emissions Units Only)**

Rule Applicability Analysis (Required for Category II applications and Category III applications involving non Title-V sources. See Instructions.)

This facility will be subject to 40 CFR, Part 60, subpart 000.

List of Applicable Regulations (Required for Category I applications and Category III applications involving Title-V sources. See Instructions.)

| | |
|-----------------------------------|--|
| 62-212.200(56) FAC | |
| 62-296.800 FAC | |
| 40 CFR 60, Subpart 000 | |
| 62-296.310 (2) FAC | |
| 62-297 FAC | |
| 62-297.340 FAC | |
| 62-297.350 FAC | |
| 62-210.350 FAC | |
| Chapter 84-446, Section 3 (12) FS | |
| 62-296.320 FAC | |
| 62-296.310 (3) FAC | |
| 40 CFR 60.11 (d) | |
| 62-4 FAC | |
| 62-210 | |
| | |
| | |
| | |
| | |
| | |
| | |

**E. EMISSION POINT (STACK/VENT) INFORMATION
(Regulated Emissions Units Only)**

Emission Point Description and Type

| | |
|---|------|
| 1. Identification of Point on Plot Plan or Flow Diagram: Raw Material Receiving Hopper / Vibrating Grizzly Feeder | |
| 2. Emission Point Type Code: <input type="checkbox"/> 1 <input type="checkbox"/> 2 <input type="checkbox"/> 3 <input checked="" type="checkbox"/> 4 | |
| 2. Descriptions of Emissions Points Comprising this Emissions Unit for VE Tracking (limit to 100 characters per point): <p>Visible Emissions testing will be read in the vicinity of the receiving hopper / grizzly feeder area, probably above the receiving hopper.</p> | |
| 4. ID Numbers or Descriptions of Emission Units with this Emission Point in Common: <p>NOT APPLICABLE</p> | |
| 5. Discharge Type Code: <input type="checkbox"/> D <input checked="" type="checkbox"/> F <input type="checkbox"/> H <input type="checkbox"/> P <input type="checkbox"/> R <input type="checkbox"/> V <input type="checkbox"/> W | |
| 6. Stack Height: NOT APPLICABLE | feet |
| 7. Exit Diameter: | feet |
| 8. Exit Temperature: | °F |
| 9. Actual Volumetric Flow Rate: | acfm |

Emissions Unit Information Section 1 of 9

| | |
|--|-------|
| 10. Percent Water Vapor : | % |
| 11. Maximum Dry Standard Flow Rate: | dscfm |
| 12. Nonstack Emission Point Height: ~ 15.0 feet | |
| 13. Emission Point UTM Coordinates: <i>(for base/main location of crushing unit only, others not determined as of yet.)</i> Zone: 17 East (km): 499.7 North (km): 3225.5 | |
| 14. Emission Point Comment (limit to 200 characters): Emissions Point will be fugitive only, if any emissions are generated at all. | |

**F. SEGMENT (PROCESS/FUEL) INFORMATION
(Regulated and Unregulated Emissions Units)**

Segment Description and Rate: Segment _____ of _____

| | |
|--|--|
| 1. Segment Description (Process/Fuel Type and Associated Operating Method/Mode) (limit to 500 characters): Eagle Crusher Company, Inc. – Portable Crushing Unit – Raw Material Receiving Hopper / Vibrating Grizzly Feeder System. (Material Handling - Emissions related to vibrating and screening of reclaimed material) | |
| 2. Source Classification Code (SCC): 30502511 | |
| 3. SCC Units: tons product processed | |
| 4. Maximum Hourly Rate: 250 ton/hr | 5. Maximum Annual Rate: 780,000 ton/yr |
| 6. Estimated Annual Activity Factor: NA | |
| 7. Maximum Percent Sulfur: NA | 8. Maximum Percent Ash: |
| 9. Million Btu per SCC Unit: NA | |
| 10. Segment Comment (limit to 200 characters): | |

Segment Description and Rate: Segment of

| | |
|---|-------------------------|
| 1. Segment Description (Process/Fuel Type and Associated Operating Method/Mode) (limit to 500 characters): | |
| 2. Source Classification Code (SCC): | |
| 3. SCC Units: | |
| 4. Maximum Hourly Rate: | 5. Maximum Annual Rate: |
| 6. Estimated Annual Activity Factor: | |
| 7. Maximum Percent Sulfur: | 8. Maximum Percent Ash: |
| 9. Million Btu per SCC Unit: | |
| 10. Segment Comment (limit to 200 characters): | |

**G. EMISSIONS UNIT POLLUTANTS
(Regulated and Unregulated Emissions Units)**

| 1. Pollutant Emitted | 2. Primary Control Device Code | 3. Secondary Control Device Code | 4. Pollutant Regulatory Code |
|----------------------|--------------------------------|----------------------------------|------------------------------|
| PM 10 | 061 | 099 | WP |
| TSP | 061 | 099 | WP |
| | | | |
| | | | |
| | | | |
| | | | |
| | | | |
| | | | |
| | | | |
| | | | |
| | | | |
| | | | |
| | | | |
| | | | |
| | | | |
| | | | |
| | | | |
| | | | |
| | | | |
| | | | |
| | | | |
| | | | |
| | | | |
| | | | |

**H. EMISSIONS UNIT POLLUTANT DETAIL INFORMATION
(Regulated Emissions Units Only - Emissions Limited Pollutants Only)**

Pollutant Detail Information: Pollutant 1 of 1

| |
|--|
| 1. Pollutant Emitted: PM₁₀ , TSP |
| 2. Total Percent Efficiency of Control: 80 % |
| 3. Potential Emissions: PM₁₀_{hourly} = 0.53 lb/hr PM₁₀_{yaerly} = 0.82 ton/yr TSP_{hourly} = 1.11 lb/hr TSP_{yearly} = 1.72 ton/yr |
| 4. Synthetically Limited? <input checked="" type="checkbox"/> Yes <input type="checkbox"/> No |
| 5. Range of Estimated Fugitive/Other Emissions: <input type="checkbox"/> 1 <input type="checkbox"/> 2 <input type="checkbox"/> 3 <u> 0 </u> to <u> 0 </u> tons/year |
| 6. Emission Factor: 0.0021 lbs/ton Reference: AP-42 (Table 11.19.2-2 controlled) and footnote © for TSP Emissions |
| 7. Emissions Method Code: <input type="checkbox"/> 0 <input type="checkbox"/> 1 <input type="checkbox"/> 2 <input checked="" type="checkbox"/> 3 <input type="checkbox"/> 4 <input type="checkbox"/> 5 |
| 8. Calculation of Emissions (limit to 600 characters): PM₁₀_{yearly} = [(250 ton/hr)(3120 hr/yr)(0.0021 lb/ton)] / (2000 lb/ton) = 0.82 ton/yr PM₁₀_{hour} = [(250 ton/hr)(0.0021 lb/ton)] = 0.53 lb/hr TSP_{yearly} = [(250 ton/hr)(3120 hr/yr)(0.0021 lb/ton)] (2.1) / (2000 lb/ton) = 1.72 ton/yr TSP_{hour} = [(200 ton/hr)(0.0021 lb/ton)] (2.1) = 1.11 lb/hr |
| 9. Pollutant Potential/Estimated Emissions Comment (limit to 200 characters): Raw Material Receiving Hopper / Grizzly Feeder – subject to subpart 000 rules and regulations. |

Allowable Emissions (Pollutant identified on front of page)

A.

| | | |
|---|---------|-----------|
| 1. Basis for Allowable Emissions Code: This facility will be subject to 40 CFR Part 60, Subpart 000 rules and regulations. | | |
| 2. Future Effective Date of Allowable Emissions: Initial Visible Emissions Compliance Test | | |
| 3. Requested Allowable Emissions and Units: < 5% Opacity | | |
| 4. Equivalent Allowable Emissions: | lb/hour | tons/year |
| 5. Method of Compliance (limit to 60 characters): Annual EPA Method 9 Compliance Testing. | | |
| 6. Pollutant Allowable Emissions Comment (Desc. of Related Operating Method/Mode) (limit to 200 characters): | | |

B.

| | | |
|---|-------|-----------|
| 1. Basis for Allowable Emissions Code: | | |
| 2. Future Effective Date of Allowable Emissions: | | |
| 3. Requested Allowable Emissions and Units: | | |
| 4. Equivalent Allowable Emissions: | lb/hr | tons/year |
| 5. Method of Compliance (limit to 60 characters): | | |
| 6. Pollutant Allowable Emissions Comment (Desc. of Related Operating Method/Mode) (limit to 200 characters): | | |

**I. VISIBLE EMISSIONS INFORMATION
(Regulated Emissions Units Only)**

Visible Emissions Limitation: Visible Emissions Limitation 1 of 1

| |
|--|
| 1. Visible Emissions Subtype: VE |
| 2. Basis for Allowable Opacity: <input checked="" type="checkbox"/> Rule <input type="checkbox"/> Other |
| 3. Requested Allowable Opacity: Normal Conditions: < 5 % Exceptional Conditions: < 5 % Maximum Period of Excess Opacity Allowed: 0 min/hour |
| 4. Method of Compliance: Annual EPA Method 9 visible emission testing. |
| 5. Visible Emissions Comment (limit to 200 characters): |

Visible Emissions Limitation: Visible Emissions Limitation _____ of _____

| |
|--|
| 1. Visible Emissions Subtype: |
| 2. Basis for Allowable Opacity: <input type="checkbox"/> Rule <input type="checkbox"/> Other |
| 3. Requested Allowable Opacity: Normal Conditions: _____ % Exceptional Conditions: _____ % Maximum Period of Excess Opacity Allowed: _____ min/hour |
| 4. Method of Compliance: |
| 5. Visible Emissions Comment (limit to 200 characters): |

**J. CONTINUOUS MONITOR INFORMATION
(Regulated Emissions Units Only)**

Continuous Monitoring System: Continuous Monitor of

| | |
|---|--|
| 1. Parameter Code: NOT APPLICABLE | 2. Pollutant(s): |
| 3. CMS Requirement: | <input type="checkbox"/> Rule <input type="checkbox"/> Other |
| 4. Monitor Information: Manufacturer: Model Number: | |
| | Serial Number: |
| 5. Installation Date: | |
| 6. Performance Specification Test Date: | |
| 7. Continuous Monitor Comment (limit to 200 characters): NOT APPLICABLE | |

Continuous Monitoring System: Continuous Monitor of

| | |
|---|--|
| 1. Parameter Code: | 2. Pollutant(s): |
| 3. CMS Requirement: | <input type="checkbox"/> Rule <input type="checkbox"/> Other |
| 4. Monitor Information: Manufacturer: Model Number: | |
| | Serial Number: |
| 5. Installation Date: | |
| 6. Performance Specification Test Date: | |
| 7. Continuous Monitor Comment (limit to 200 characters): | |

**K. PREVENTION OF SIGNIFICANT DETERIORATION (PSD) INCREMENT
TRACKING INFORMATION
(Regulated and Unregulated Emissions Units)**

PSD Increment Consumption Determination

1. Increment Consuming for Particulate Matter or Sulfur Dioxide?

If the emissions unit addressed in this section emits particulate matter or sulfur dioxide, answer the following series of questions to make a preliminary determination as to whether or not the emissions unit consumes PSD increment for particulate matter or sulfur dioxide. Check the first statement, if any, that applies and skip remaining statements.

-] The emissions unit is undergoing PSD review as part of this application, or has undergone PSD review previously, for particulate matter or sulfur dioxide. If so, emissions unit consumes increment.
-] The facility addressed in this application is classified as an EPA major source pursuant to paragraph (c) of the definition of "major source of air pollution" in Chapter 62-213, F.A.C., and the emissions unit addressed in this section commenced (or will commence) construction after January 6, 1975. If so, baseline emissions are zero, and emissions unit consumes increment.
-] The facility addressed in this application is classified as an EPA major source, and the emissions unit began initial operation after January 6, 1975, but before December 27, 1977. If so, baseline emissions are zero, and emissions unit consumes increment.
-] For any facility, the emissions unit began (or will begin) initial operation after December 27, 1977. If so, baseline emissions are zero, and emissions unit consumes increment.
-] None of the above apply. If so, the baseline emissions of the emissions unit are nonzero. In such case, additional analysis, beyond the scope of this application, is needed to determine whether changes in emissions have occurred (or will occur) after the baseline date that may consume or expand increment.

2. Increment Consuming for Nitrogen Dioxide?

If the emissions unit addressed in this section emits nitrogen oxides, answer the following series of questions to make a preliminary determination as to whether or not the emissions unit consumes PSD increment for nitrogen dioxide. Check first statement, if any, that applies and skip remaining statements.

-] The emissions unit addressed in this section is undergoing PSD review as part of this application, or has undergone PSD review previously, for nitrogen dioxide. If so, emissions unit consumes increment.
-] The facility addressed in this application is classified as an EPA major source pursuant to paragraph (c) of the definition of "major source of air pollution" in Chapter 62-213, F.A.C., and the emissions unit addressed in this section commenced (or will commence) construction after February 8, 1988. If so, baseline emissions are zero, and emissions unit consumes increment.
-] The facility addressed in this application is classified as an EPA major source, and the emissions unit began initial operation after February 8, 1988, but before March 28, 1988. If so, baseline emissions are zero, and emissions unit consumes increment.
-] For any facility, the emissions unit began (or will begin) initial operation after March 28, 1988. If so, baseline emissions are zero, and emissions unit consumes increment.
-] None of the above apply. If so, the baseline emissions of the emissions unit are nonzero. In such case, additional analysis, beyond the scope of this application, is needed to determine whether changes in emissions have occurred (or will occur) after the baseline date that may consume or expand increment.

| | | | |
|---|------------------------------|------------------------------|---|
| 3. Increment Consuming/Expanding Code: | | | |
| PM | <input type="checkbox"/>] C | <input type="checkbox"/>] E | <input checked="" type="checkbox"/>] Unknown |
| SO2 | <input type="checkbox"/>] C | <input type="checkbox"/>] E | <input checked="" type="checkbox"/>] Unknown |
| NO2 | <input type="checkbox"/>] C | <input type="checkbox"/>] E | <input checked="" type="checkbox"/>] Unknown |
| 4. Baseline Emissions: | | | |
| PM ₁₀ / TSP | 0.53 / 1.11 lb/hour | 0.82 / 1.72 tons/year | |
| SO2 | lb/hour | tons/year | |
| NO2 | | tons/year | |
| 5. PSD Comment (limit to 200 characters): | | | |
| | | | |

**L. EMISSIONS UNIT SUPPLEMENTAL INFORMATION
(Regulated Emissions Units Only)**

Supplemental Requirements for All Applications

| |
|---|
| 1. Process Flow Diagram <input checked="" type="checkbox"/> Attached, Document ID: <u> III </u> [] Not Applicable [] Waiver Requested |
| 2. Fuel Analysis or Specification [] Attached, Document ID: _____ [] Not Applicable [] Waiver Requested |
| 3. Detailed Description of Control Equipment <input checked="" type="checkbox"/> Attached, Document ID: <u> V </u> [] Not Applicable [] Waiver Requested |
| 4. Description of Stack Sampling Facilities [] Attached, Document ID: _____ <input checked="" type="checkbox"/> Not Applicable [] Waiver Requested |
| 5. Compliance Test Report [] Attached, Document ID: _____ [] Previously submitted, Date: _____ <input checked="" type="checkbox"/> Not Applicable |
| 6. Procedures for Startup and Shutdown [] Attached, Document ID: _____ <input checked="" type="checkbox"/> Not Applicable |
| 7. Operation and Maintenance Plan <input checked="" type="checkbox"/> Attached, Document ID: <u> VI </u> [] Not Applicable |
| 8. Supplemental Information for Construction Permit Application <input checked="" type="checkbox"/> Attached, Document ID: <u> VII </u> <input checked="" type="checkbox"/> Not Applicable |
| 9. Other Information Required by Rule or Statute [] Attached, Document ID: _____ <input checked="" type="checkbox"/> Not Applicable |

Additional Supplemental Requirements for Category I Applications Only

| |
|--|
| 10. Alternative Methods of Operation <input type="checkbox"/> Attached, Document ID: _____ <input checked="" type="checkbox"/> Not Applicable |
| 11. Alternative Modes of Operation (Emissions Trading) <input type="checkbox"/> Attached, Document ID: _____ <input checked="" type="checkbox"/> Not Applicable |
| 12. Identification of Additional Applicable Requirements <input type="checkbox"/> Attached, Document ID: _____ <input checked="" type="checkbox"/> Not Applicable |
| 13. Compliance Assurance Monitoring Plan <input type="checkbox"/> Attached, Document ID: _____ <input checked="" type="checkbox"/> Not Applicable |
| 14. Acid Rain Application (Hard-copy Required) <input type="checkbox"/> Acid Rain Part - Phase II (Form No. 62-210.900(1)(a)) Attached, Document ID: _____ <input type="checkbox"/> Repowering Extension Plan (Form No. 62-210.900(1)(a)1.) Attached, Document ID: _____ <input type="checkbox"/> New Unit Exemption (Form No. 62-210.900(1)(a)2.) Attached, Document ID: _____ <input type="checkbox"/> Retired Unit Exemption (Form No. 62-210.900(1)(a)3.) Attached, Document ID: _____ <input checked="" type="checkbox"/> Not Applicable |

EMISSIONS ID. NO. 002

DISCHARGE PAN/DISCHARGE BELT

III. EMISSIONS UNIT INFORMATION

A separate Emissions Unit Information Section (including subsections A through L as required) must be completed for each emissions unit addressed in this Application for Air Permit. If submitting the application form in hard copy, indicate, in the space provided at the top of each page, the number of this Emissions Unit Information Section and the total number of Emissions Unit Information Sections submitted as part of this application. Some of the subsections comprising the Emissions Unit Information Section of the form are intended for regulated emissions units only. Others are intended for both regulated and unregulated emissions units. Each subsection is appropriately marked.

A. TYPE OF EMISSIONS UNIT (Regulated and Unregulated Emissions Units)

Type of Emissions Unit Addressed in This Section

1. Regulated or Unregulated Emissions Unit? Check one:

The emissions unit addressed in this Emissions Unit Information Section is a regulated emissions unit.

The emissions unit addressed in this Emissions Unit Information Section is an unregulated emissions unit.

2. Single Process, Group of Processes, or Fugitive Only? Check one:

This Emissions Unit Information Section addresses, as a single emissions unit, a single process or production unit, or activity, which produces one or more air pollutants and which has at least one definable emission point (stack or vent).

This Emissions Unit Information Section addresses, as a single emissions unit, a group of process or production units and activities which has at least one definable emission point (stack or vent) but may also produce fugitive emissions.

This Emissions Unit Information Section addresses, as a single emissions unit, one or more process or production units and activities which produce fugitive emissions only.

**B. GENERAL EMISSIONS UNIT INFORMATION
(Regulated and Unregulated Emissions Units)**

Emissions Unit Description and Status

| | | |
|---|--------------------------------------|--|
| 1. Description of Emissions Unit Addressed in This Section (limit to 60 characters): Bohringer Machinery Company, Inc. – Under Crusher Gathering Hopper / Discharge Pan – where crushed material exits crushing unit to conveying system. | | |
| 2. Emissions Unit Identification Number: [] No Corresponding ID [X] Unknown | | |
| 3. Emissions Unit Status Code: Construction | 4. Acid Rain Unit? [] Yes [X] No | 5. Emissions Unit Major Group SIC Code: 14 |
| 6. Emissions Unit Comment (limit to 500 characters): | | |

Emissions Unit Control Equipment

A.

| |
|--|
| 3. Description (limit to 200 characters): The fugitive emissions generated by crushing of material and this material being dropped into the Under Crusher Gathering Hopper / Discharge Pan to conveying system are controlled by water spray bar system mounted at discharge pan / conveying system area, used to dampen the material to control any emissions generated coming out of the crusher or being dropped into discharge pan or conveying system. The material that is to be crushed is also is dampened in it's stockpile as needed, as to control emissions in the crushing unit as well as any fugitives generated by prevailing winds. |
| 2. Control Device or Method Code: <p align="center">061, 099</p> |

B.

| |
|---|
| 1. Description (limit to 200 characters): |
| |
| 2. Control Device or Method Code: |
| |

C.

| |
|---|
| 1. Description (limit to 200 characters): |
| |
| 2. Control Device or Method Code: |
| |

**C. EMISSIONS UNIT DETAIL INFORMATION
(Regulated Emissions Units Only)**

Emissions Unit Details

| |
|---|
| 1. Initial Startup Date: ASAP |
| 2. Long-term Reserve Shutdown Date: NOT APPLICABLE |
| 3. Package Unit: Discharge Pan/Belt Manufacturer: Bohringer Machinery Company, Inc. Model No: RC-10 |
| 4. Generator Nameplate Rating: MW |
| 5. Incinerator Information: <div style="text-align: right; margin-right: 100px;">Dwell Temperature: °F</div> <div style="text-align: right; margin-right: 100px;">Dwell Time: seconds</div> <div style="text-align: right; margin-right: 100px;">Incinerator Afterburner Temperature: °F</div> |

Emissions Unit Operating Capacity

| | |
|---|---|
| 1. Maximum Heat Input Rate: NONE | mmBtu/hr |
| 2. Maximum Incineration Rate: NA | lb/hr tons/day |
| 3. Maximum Process or Throughput Rate: 250 ton/hr as raw (uncrushed) reclaimed asphalt or concrete | |
| 4. Maximum Production Rate: 250 ton/hr as reclaimed crushed concrete or asphalt material. | |
| 5. Operating Capacity Comment (limit to 200 characters): The fugitive emissions generated by crushing of material and this material being dropped into the Under Crusher Discharge Pan / Belt to conveying system are controlled by water spray bar system mounted in the area of the discharge pan / conveying system, used to dampen the material to control any emissions generated coming out of the crusher or being dropped into discharge pan or conveying system. | |

Emissions Unit Operating Schedule

| | |
|---------------------------------------|-----------------|
| Requested Maximum Operating Schedule: | |
| 10 hours/day | 6 days/week |
| 52 weeks/year | 3120 hours/year |

**D. EMISSIONS UNIT REGULATIONS
(Regulated Emissions Units Only)**

Rule Applicability Analysis (Required for Category II applications and Category III applications involving non Title-V sources. See Instructions.)

This facility will be subject to 40 CFR, Part 60, subpart 000 rules and regulations.

List of Applicable Regulations (Required for Category I applications and Category III applications involving Title-V sources. See Instructions.)

| | |
|--|--|
| 62-212.200(56) FAC | |
| 62-296.800 FAC | |
| 40 CFR 60, Subpart 000 | |
| 62-296.310 (2) FAC | |
| 62-297 FAC | |
| 62-297.340 FAC | |
| 62-297.350 FAC | |
| 62-210.350 FAC | |
| Chapter 84-446, Section 3 (12) FS | |
| 62-296.320 FAC | |
| 62-296.310 (3) FAC | |
| 40 CFR 60.11 (d) | |
| 62-4 FAC | |
| 62-210 | |
| | |
| | |
| | |
| | |
| | |
| | |

**E. EMISSION POINT (STACK/VENT) INFORMATION
(Regulated Emissions Units Only)**

Emission Point Description and Type

| |
|--|
| 1. Identification of Point on Plot Plan or Flow Diagram: Crusher Discharge Pan / Discharge Belt |
| 2. Emission Point Type Code: <input type="checkbox"/> 1 <input type="checkbox"/> 2 <input type="checkbox"/> 3 <input checked="" type="checkbox"/> 4 |
| 4. Descriptions of Emissions Points Comprising this Emissions Unit for VE Tracking (limit to 100 characters per point): <p align="center">Visible Emissions will be determined in the area of discharge pan, where material exits bottom of crusher.</p> |
| 4. ID Numbers or Descriptions of Emission Units with this Emission Point in Common: <p align="center">NOT APPLICABLE</p> |
| 5. Discharge Type Code: <input type="checkbox"/> D <input checked="" type="checkbox"/> F <input type="checkbox"/> H <input type="checkbox"/> P <input type="checkbox"/> R <input type="checkbox"/> V <input type="checkbox"/> W |
| 6. Stack Height: NOT APPLICABLE feet |
| 7. Exit Diameter: feet |
| 8. Exit Temperature: °F |
| 9. Actual Volumetric Flow Rate: acfm |

Emissions Unit Information Section 2 of 9

| | |
|---|-------|
| 10. Percent Water Vapor : | % |
| 11. Maximum Dry Standard Flow Rate: | dscfm |
| 12. Nonstack Emission Point Height: ~ 5.0 feet | |
| 13. Emission Point UTM Coordinates: <i>(for base/main location of crushing unit only, others not determined as of yet.)</i> Zone: 17 East (km): 499.7 North (km): 3225.5 | |
| 14. Emission Point Comment (limit to 200 characters): Emissions Point will be fugitive only, if any emissions are generated at all. | |

**F. SEGMENT (PROCESS/FUEL) INFORMATION
(Regulated and Unregulated Emissions Units)**

Segment Description and Rate: Segment _____ of _____

| | |
|---|--|
| <p>1. Segment Description (Process/Fuel Type and Associated Operating Method/Mode) (limit to 500 characters):</p> <p>Bohringer Machinery Company, Inc. – Portable Crushing Unit – Crusher Discharge Pan/Belt. (Material Handling - Emissions related to dropping material out of crusher onto belt.)</p> | |
| <p>2. Source Classification Code (SCC): 30502511</p> | |
| <p>3. SCC Units: tons product processed</p> | |
| <p>4. Maximum Hourly Rate: 250 ton/hr</p> | <p>5. Maximum Annual Rate: 780,000 ton/yr</p> |
| <p>6. Estimated Annual Activity Factor: NA</p> | |
| <p>7. Maximum Percent Sulfur: NA</p> | <p>8. Maximum Percent Ash:</p> |
| <p>9. Million Btu per SCC Unit: NA</p> | |
| <p>10. Segment Comment (limit to 200 characters):</p> | |

Segment Description and Rate: Segment of

| | |
|---|-------------------------|
| 1. Segment Description (Process/Fuel Type and Associated Operating Method/Mode) (limit to 500 characters): | |
| 2. Source Classification Code (SCC): | |
| 3. SCC Units: | |
| 4. Maximum Hourly Rate: | 5. Maximum Annual Rate: |
| 6. Estimated Annual Activity Factor: | |
| 7. Maximum Percent Sulfur: | 8. Maximum Percent Ash: |
| 9. Million Btu per SCC Unit: | |
| 10. Segment Comment (limit to 200 characters): | |

**G. EMISSIONS UNIT POLLUTANTS
(Regulated and Unregulated Emissions Units)**

| 1. Pollutant Emitted | 2. Primary Control Device Code | 3. Secondary Control Device Code | 4. Pollutant Regulatory Code |
|----------------------|--------------------------------|----------------------------------|------------------------------|
| PM 10 | 061 | 099 | WP |
| TSP | 061 | 099 | WP |
| | | | |
| | | | |
| | | | |
| | | | |
| | | | |
| | | | |
| | | | |
| | | | |
| | | | |
| | | | |
| | | | |
| | | | |
| | | | |
| | | | |
| | | | |
| | | | |
| | | | |
| | | | |
| | | | |
| | | | |
| | | | |

**H. EMISSIONS UNIT POLLUTANT DETAIL INFORMATION
(Regulated Emissions Units Only - Emissions Limited Pollutants Only)**

Pollutant Detail Information: Pollutant 1 of 1

| |
|--|
| 1. Pollutant Emitted: PM₁₀ , TSP |
| 2. Total Percent Efficiency of Control: 80 % |
| 3. Potential Emissions: PM₁₀_{hourly} = 0.53 lb/hr PM₁₀_{yearly} = 0.82 ton/yr TSP_{hourly} = 1.11 lb/hr TSP_{yearly} = 1.72 ton/yr |
| 4. Synthetically Limited? <input checked="" type="checkbox"/> Yes <input type="checkbox"/> No |
| 5. Range of Estimated Fugitive/Other Emissions: <input type="checkbox"/> 1 <input type="checkbox"/> 2 <input type="checkbox"/> 3 <u> 0 </u> to <u> 0 </u> tons/year |
| 6. Emission Factor: 0.0021 lbs/ton Reference: AP-42 (Table 11.19.2-2 controlled) and footnote © for TSP Emissions |
| 7. Emissions Method Code: <input type="checkbox"/> 0 <input type="checkbox"/> 1 <input type="checkbox"/> 2 <input checked="" type="checkbox"/> 3 <input type="checkbox"/> 4 <input type="checkbox"/> 5 |
| 8. Calculation of Emissions (limit to 600 characters): PM₁₀_{yearly} = [(250 ton/hr)(3120 hr/yr)(0.0021 lb/ton)] / (2000 lb/ton) = 0.82 ton/yr PM₁₀_{hour} = [(250 ton/hr)(0.0021 lb/ton)] = 0.53 lb/hr TSP_{yearly} = [(250 ton/hr)(3120 hr/yr)(0.0021 lb/ton)] (2.1) / (2000 lb/ton) = 1.72 ton/yr TSP_{hour} = [(200 ton/hr)(0.0021 lb/ton)] (2.1) = 1.11 lb/hr |
| 9. Pollutant Potential/Estimated Emissions Comment (limit to 200 characters): Discharge Pan/Belt Emissions – subject to CFR40, subpart 000. |

Allowable Emissions (Pollutant identified on front of page)

A.

| | | |
|---|---------|-----------|
| 1. Basis for Allowable Emissions Code: This facility will be subject to 40 CFR Part 60, Subpart 000 rules and regulations. | | |
| 2. Future Effective Date of Allowable Emissions: Initial Visible Emissions Compliance Test | | |
| 3. Requested Allowable Emissions and Units: < 5% Opacity | | |
| 4. Equivalent Allowable Emissions: | lb/hour | tons/year |
| 5. Method of Compliance (limit to 60 characters): Annual EPA Method 9 Compliance Testing. | | |
| 6. Pollutant Allowable Emissions Comment (Desc. of Related Operating Method/Mode) (limit to 200 characters): | | |

B.

| | | |
|---|-------|-----------|
| 1. Basis for Allowable Emissions Code: | | |
| 2. Future Effective Date of Allowable Emissions: | | |
| 3. Requested Allowable Emissions and Units: | | |
| 4. Equivalent Allowable Emissions: | lb/hr | tons/year |
| 5. Method of Compliance (limit to 60 characters): | | |
| 6. Pollutant Allowable Emissions Comment (Desc. of Related Operating Method/Mode) (limit to 200 characters): | | |

**I. VISIBLE EMISSIONS INFORMATION
(Regulated Emissions Units Only)**

Visible Emissions Limitation: Visible Emissions Limitation 1 of 1

| |
|---|
| 1. Visible Emissions Subtype: VE |
| 2. Basis for Allowable Opacity: <input checked="" type="checkbox"/> Rule <input type="checkbox"/> Other |
| 3. Requested Allowable Opacity: Normal Conditions: < 10 % Exceptional Conditions: < 10 % Maximum Period of Excess Opacity Allowed: 0 min/hour |
| 4. Method of Compliance: Annual EPA Method 9 visible emission testing. |
| 5. Visible Emissions Comment (limit to 200 characters): |

Visible Emissions Limitation: Visible Emissions Limitation _____ of _____

| |
|---|
| 1. Visible Emissions Subtype: |
| 2. Basis for Allowable Opacity: <input type="checkbox"/> Rule <input type="checkbox"/> Other |
| 3. Requested Allowable Opacity: Normal Conditions: % Exceptional Conditions: % Maximum Period of Excess Opacity Allowed: min/hour |
| 4. Method of Compliance: |
| 5. Visible Emissions Comment (limit to 200 characters): |

**J. CONTINUOUS MONITOR INFORMATION
(Regulated Emissions Units Only)**

Continuous Monitoring System: Continuous Monitor _____ of _____

| | |
|---|--|
| 1. Parameter Code: NOT APPLICABLE | 2. Pollutant(s): |
| 3. CMS Requirement: | <input type="checkbox"/> Rule <input type="checkbox"/> Other |
| 4. Monitor Information: Manufacturer: Model Number: Serial Number: | |
| 5. Installation Date: | |
| 6. Performance Specification Test Date: | |
| 7. Continuous Monitor Comment (limit to 200 characters): NOT APPLICABLE | |

Continuous Monitoring System: Continuous Monitor _____ of _____

| | |
|--|--|
| 1. Parameter Code: | 2. Pollutant(s): |
| 3. CMS Requirement: | <input type="checkbox"/> Rule <input type="checkbox"/> Other |
| 4. Monitor Information: Manufacturer: Model Number: Serial Number: | |
| 5. Installation Date: | |
| 6. Performance Specification Test Date: | |
| 7. Continuous Monitor Comment (limit to 200 characters): | |

**K. PREVENTION OF SIGNIFICANT DETERIORATION (PSD) INCREMENT
TRACKING INFORMATION
(Regulated and Unregulated Emissions Units)**

PSD Increment Consumption Determination

1. Increment Consuming for Particulate Matter or Sulfur Dioxide?

If the emissions unit addressed in this section emits particulate matter or sulfur dioxide, answer the following series of questions to make a preliminary determination as to whether or not the emissions unit consumes PSD increment for particulate matter or sulfur dioxide. Check the first statement, if any, that applies and skip remaining statements.

- [] The emissions unit is undergoing PSD review as part of this application, or has undergone PSD review previously, for particulate matter or sulfur dioxide. If so, emissions unit consumes increment.
- [] The facility addressed in this application is classified as an EPA major source pursuant to paragraph (c) of the definition of "major source of air pollution" in Chapter 62-213, F.A.C., and the emissions unit addressed in this section commenced (or will commence) construction after January 6, 1975. If so, baseline emissions are zero, and emissions unit consumes increment.
- [] The facility addressed in this application is classified as an EPA major source, and the emissions unit began initial operation after January 6, 1975, but before December 27, 1977. If so, baseline emissions are zero, and emissions unit consumes increment.
- [] For any facility, the emissions unit began (or will begin) initial operation after December 27, 1977. If so, baseline emissions are zero, and emissions unit consumes increment.
- [X] None of the above apply. If so, the baseline emissions of the emissions unit are nonzero. In such case, additional analysis, beyond the scope of this application, is needed to determine whether changes in emissions have occurred (or will occur) after the baseline date that may consume or expand increment.

Emissions Unit Information Section 2 of 9

2. Increment Consuming for Nitrogen Dioxide?

If the emissions unit addressed in this section emits nitrogen oxides, answer the following series of questions to make a preliminary determination as to whether or not the emissions unit consumes PSD increment for nitrogen dioxide. Check first statement, if any, that applies and skip remaining statements.

-] The emissions unit addressed in this section is undergoing PSD review as part of this application, or has undergone PSD review previously, for nitrogen dioxide. If so, emissions unit consumes increment.
-] The facility addressed in this application is classified as an EPA major source pursuant to paragraph (c) of the definition of "major source of air pollution" in Chapter 62-213, F.A.C., and the emissions unit addressed in this section commenced (or will commence) construction after February 8, 1988. If so, baseline emissions are zero, and emissions unit consumes increment.
-] The facility addressed in this application is classified as an EPA major source, and the emissions unit began initial operation after February 8, 1988, but before March 28, 1988. If so, baseline emissions are zero, and emissions unit consumes increment.
-] For any facility, the emissions unit began (or will begin) initial operation after March 28, 1988. If so, baseline emissions are zero, and emissions unit consumes increment.
-] None of the above apply. If so, the baseline emissions of the emissions unit are nonzero. In such case, additional analysis, beyond the scope of this application, is needed to determine whether changes in emissions have occurred (or will occur) after the baseline date that may consume or expand increment.

| | | |
|---|------------------------------|--|
| 3. Increment Consuming/Expanding Code: | | |
| PM | <input type="checkbox"/>] C | <input type="checkbox"/>] E <input checked="" type="checkbox"/>] Unknown |
| SO2 | <input type="checkbox"/>] C | <input checked="" type="checkbox"/>] Unknown |
| NO2 | <input type="checkbox"/>] C | <input checked="" type="checkbox"/>] Unknown |
| 4. Baseline Emissions: | | |
| PM ₁₀ / TSP | 0.53 / 1.11 lb/hour | 0.82 / 1.72 tons/year |
| SO2 | lb/hour | tons/year |
| NO2 | | tons/year |
| 5. PSD Comment (limit to 200 characters): | | |
| | | |

**L. EMISSIONS UNIT SUPPLEMENTAL INFORMATION
(Regulated Emissions Units Only)**

Supplemental Requirements for All Applications

| |
|--|
| 1. Process Flow Diagram <input checked="" type="checkbox"/> Attached, Document ID: <u> III </u> [] Not Applicable [] Waiver Requested |
| 2. Fuel Analysis or Specification <input type="checkbox"/> Attached, Document ID: _____ [] Not Applicable [] Waiver Requested |
| 3. Detailed Description of Control Equipment <input checked="" type="checkbox"/> Attached, Document ID: <u> V </u> [] Not Applicable [] Waiver Requested |
| 4. Description of Stack Sampling Facilities <input type="checkbox"/> Attached, Document ID: _____ <input checked="" type="checkbox"/> Not Applicable [] Waiver Requested |
| 5. Compliance Test Report <input type="checkbox"/> Attached, Document ID: _____ <input type="checkbox"/> Previously submitted, Date: _____ <input checked="" type="checkbox"/> Not Applicable |
| 6. Procedures for Startup and Shutdown <input type="checkbox"/> Attached, Document ID: _____ <input checked="" type="checkbox"/> Not Applicable |
| 7. Operation and Maintenance Plan <input checked="" type="checkbox"/> Attached, Document ID: <u> VI </u> [] Not Applicable |
| 8. Supplemental Information for Construction Permit Application <input checked="" type="checkbox"/> Attached, Document ID: <u> VII </u> <input checked="" type="checkbox"/> Not Applicable |
| 9. Other Information Required by Rule or Statute <input type="checkbox"/> Attached, Document ID: _____ <input checked="" type="checkbox"/> Not Applicable |

Additional Supplemental Requirements for Category I Applications Only

| |
|--|
| 10. Alternative Methods of Operation <input type="checkbox"/> Attached, Document ID: _____ <input checked="" type="checkbox"/> Not Applicable |
| 11. Alternative Modes of Operation (Emissions Trading) <input type="checkbox"/> Attached, Document ID: _____ <input checked="" type="checkbox"/> Not Applicable |
| 12. Identification of Additional Applicable Requirements <input type="checkbox"/> Attached, Document ID: _____ <input checked="" type="checkbox"/> Not Applicable |
| 13. Compliance Assurance Monitoring Plan <input type="checkbox"/> Attached, Document ID: _____ <input checked="" type="checkbox"/> Not Applicable |
| 14. Acid Rain Application (Hard-copy Required) <input type="checkbox"/> Acid Rain Part - Phase II (Form No. 62-210.900(1)(a)) Attached, Document ID: _____ <input type="checkbox"/> Repowering Extension Plan (Form No. 62-210.900(1)(a)1.) Attached, Document ID: _____ <input type="checkbox"/> New Unit Exemption (Form No. 62-210.900(1)(a)2.) Attached, Document ID: _____ <input type="checkbox"/> Retired Unit Exemption (Form No. 62-210.900(1)(a)3.) Attached, Document ID: _____ <input checked="" type="checkbox"/> Not Applicable |

EMISSIONS ID. NO. 003

CRUSHER BELT TO PRE-SCREENER BELT
(DROP POINT)

III. EMISSIONS UNIT INFORMATION

A separate Emissions Unit Information Section (including subsections A through L as required) must be completed for each emissions unit addressed in this Application for Air Permit. If submitting the application form in hard copy, indicate, in the space provided at the top of each page, the number of this Emissions Unit Information Section and the total number of Emissions Unit Information Sections submitted as part of this application. Some of the subsections comprising the Emissions Unit Information Section of the form are intended for regulated emissions units only. Others are intended for both regulated and unregulated emissions units. Each subsection is appropriately marked.

A. TYPE OF EMISSIONS UNIT (Regulated and Unregulated Emissions Units)

Type of Emissions Unit Addressed in This Section

1. Regulated or Unregulated Emissions Unit? Check one:

The emissions unit addressed in this Emissions Unit Information Section is a regulated emissions unit.

The emissions unit addressed in this Emissions Unit Information Section is an unregulated emissions unit.

2. Single Process, Group of Processes, or Fugitive Only? Check one:

This Emissions Unit Information Section addresses, as a single emissions unit, a single process or production unit, or activity, which produces one or more air pollutants and which has at least one definable emission point (stack or vent).

This Emissions Unit Information Section addresses, as a single emissions unit, a group of process or production units and activities which has at least one definable emission point (stack or vent) but may also produce fugitive emissions.

This Emissions Unit Information Section addresses, as a single emissions unit, one or more process or production units and activities which produce fugitive emissions only.

**B. GENERAL EMISSIONS UNIT INFORMATION
(Regulated and Unregulated Emissions Units)**

Emissions Unit Description and Status

| | | |
|--|---|--|
| 1. Description of Emissions Unit Addressed in This Section (limit to 60 characters): Bohringer Machinery Company, Inc. – Crusher Discharge Conveying Belt to Pre-Screener Conveying Belt (drop point where material leaves Discharge conveying belt and drops to Pre-Screening Conveying Belt) | | |
| 2. Emissions Unit Identification Number: [] No Corresponding ID [X] Unknown | | |
| 3. Emissions Unit Status Code: Construction | 4. Acid Rain Unit? [] Yes [X] No | 5. Emissions Unit Major Group SIC Code: 14 |
| 6. Emissions Unit Comment (limit to 500 characters): | | |

Emissions Unit Control Equipment

A.

| |
|---|
| 5. Description (limit to 200 characters): The fugitive emissions generated from the drop point where crushed material leaves the Crusher Discharge Belt Conveying System and is dropped onto the Pre-Screener Conveying Belt are controlled by water spray bar system mounted in the area discharge pan / discharge conveying system, on an as needed basis this spray bar system will be used to dampen the material to control any emissions generated coming out of the crusher or being dropped into discharge pan or conveying system. The material is also moistened enough as to control any emissions at the drop point mentioned above . The material that is to be crushed is also is dampened as needed, in it's stockpile as to control emissions in the crushing unit as well as any fugitives generated by prevailing winds. |
| 2. Control Device or Method Code: <p align="center">061,099</p> |

B.

| |
|---|
| 1. Description (limit to 200 characters): |
| |
| 2. Control Device or Method Code: |
| |

C.

| |
|---|
| 1. Description (limit to 200 characters): |
| |
| 2. Control Device or Method Code: |
| |

**C. EMISSIONS UNIT DETAIL INFORMATION
(Regulated Emissions Units Only)**

Emissions Unit Details

| |
|---|
| 1. Initial Startup Date: ASAP |
| 2. Long-term Reserve Shutdown Date: NOT APPLICABLE |
| 3. Package Unit: Crusher Discharge Belt and Pre-Screener Conveying Belt Manufacturer: Bohringer Machinery Company, Inc. Model No: RC10 |
| 4. Generator Nameplate Rating: MW |
| 5. Incinerator Information: <div style="text-align: right; margin-right: 100px;">Dwell Temperature: °F</div> <div style="text-align: right; margin-right: 100px;">Dwell Time: seconds</div> <div style="text-align: right; margin-right: 100px;">Incinerator Afterburner Temperature: °F</div> |

Emissions Unit Operating Capacity

| |
|---|
| 1. Maximum Heat Input Rate: NONE mmBtu/hr |
| 2. Maximum Incineration Rate: NA lb/hr tons/day |
| 3. Maximum Process or Throughput Rate: 250 ton/hr as raw (crushed) reclaimed asphalt or concrete |
| 4. Maximum Production Rate: 250 ton/hr as reclaimed crushed concrete or asphalt material. |
| 5. Operating Capacity Comment (limit to 200 characters): The fugitive emissions generated by crushing of material and this material being dropped into the Discharge Pan/Discharge Belt to conveying system are controlled by water spray bar system mounted in the area of the discharge pan / crusher discharge conveying system, used to dampen the material to control any emissions generated coming out of the crusher or being dropped into discharge pan or conveying system and the drop point at the discharge belt to Pre-Screener Conveying System. |

Emissions Unit Operating Schedule

| | |
|---------------------------------------|------------------------|
| Requested Maximum Operating Schedule: | |
| 10 hours/day | 6 days/week |
| 52 weeks/year | 3120 hours/year |

**D. EMISSIONS UNIT REGULATIONS
(Regulated Emissions Units Only)**

Rule Applicability Analysis (Required for Category II applications and Category III applications involving non Title-V sources. See Instructions.)

This facility will be subject to 40 CFR, Part 60, subpart 000 rules and regulations.

List of Applicable Regulations (Required for Category I applications and Category III applications involving Title-V sources. See Instructions.)

| | |
|-----------------------------------|--|
| 62-212.200(56) FAC | |
| 62-296.800 FAC | |
| 40 CFR 60, Subpart 000 | |
| 62-296.310 (2) FAC | |
| 62-297 FAC | |
| 62-297.340 FAC | |
| 62-297.350 FAC | |
| 62-210.350 FAC | |
| Chapter 84-446, Section 3 (12) FS | |
| 62-296.320 FAC | |
| 62-296.310 (3) FAC | |
| 40 CFR 60.11 (d) | |
| 62-4 FAC | |
| 62-210 | |
| | |
| | |
| | |
| | |
| | |
| | |

**E. EMISSION POINT (STACK/VENT) INFORMATION
(Regulated Emissions Units Only)**

Emission Point Description and Type

| | |
|----|--|
| 1. | Identification of Point on Plot Plan or Flow Diagram: Drop Point Crusher Discharge Belt and Pre-Screener Conveying System. |
| 2. | Emission Point Type Code: <input type="checkbox"/> 1 <input type="checkbox"/> 2 <input type="checkbox"/> 3 <input checked="" type="checkbox"/> 4 |
| 6. | Descriptions of Emissions Points Comprising this Emissions Unit for VE Tracking (limit to 100 characters per point): <p align="center">Visible Emissions will be determined in the area of drop point, where material exits the crusher discharge belt and falls onto the Pre-Screener Conveying System.</p> |
| 4. | ID Numbers or Descriptions of Emission Units with this Emission Point in Common: <p align="center">NOT APPLICABLE</p> |
| 5. | Discharge Type Code: <input type="checkbox"/> D <input checked="" type="checkbox"/> F <input type="checkbox"/> H <input type="checkbox"/> P <input type="checkbox"/> R <input type="checkbox"/> V <input type="checkbox"/> W |
| 6. | Stack Height: NOT APPLICABLE feet |
| 7. | Exit Diameter: feet |
| 8. | Exit Temperature: °F |
| 9. | Actual Volumetric Flow Rate: acfm |

Emissions Unit Information Section 3 of 9

| | |
|--|-------|
| 10. Percent Water Vapor : | % |
| 11. Maximum Dry Standard Flow Rate: | dscfm |
| 12. Nonstack Emission Point Height: ~ 10.0 feet | |
| 13. Emission Point UTM Coordinates: <i>(for base/main location of crushing unit only, others not determined as of yet.)</i> Zone: 17 East (km): 499.7 North (km): 3225.5 | |
| 14. Emission Point Comment (limit to 200 characters): Emissions Point will be fugitive only, if any emissions are generated at all. | |

**F. SEGMENT (PROCESS/FUEL) INFORMATION
(Regulated and Unregulated Emissions Units)**

Segment Description and Rate: Segment 1 of 1

| | |
|---|--|
| <p>1. Segment Description (Process/Fuel Type and Associated Operating Method/Mode) (limit to 500 characters):</p> <p>Bohringer Machinery Company, Inc. – Portable Crushing Unit – Drop Point between Crusher discharge belt and Pre-Screener Conveying System. (Material Handling - Emissions related to conveying of reclaimed material).</p> | |
| <p>2. Source Classification Code (SCC): 30502511</p> | |
| <p>3. SCC Units: tons product processed</p> | |
| <p>4. Maximum Hourly Rate: 250 ton/hr</p> | <p>5. Maximum Annual Rate: 780,000 ton/yr</p> |
| <p>6. Estimated Annual Activity Factor: NA</p> | |
| <p>7. Maximum Percent Sulfur: NA</p> | <p>8. Maximum Percent Ash:</p> |
| <p>9. Million Btu per SCC Unit: NA</p> | |
| <p>10. Segment Comment (limit to 200 characters):</p> | |

Segment Description and Rate: Segment _____ of _____

| | |
|---|-------------------------|
| 1. Segment Description (Process/Fuel Type and Associated Operating Method/Mode) (limit to 500 characters): | |
| 2. Source Classification Code (SCC): | |
| 3. SCC Units: | |
| 4. Maximum Hourly Rate: | 5. Maximum Annual Rate: |
| 6. Estimated Annual Activity Factor: | |
| 7. Maximum Percent Sulfur: | 8. Maximum Percent Ash: |
| 9. Million Btu per SCC Unit: | |
| 10. Segment Comment (limit to 200 characters): | |

**H. EMISSIONS UNIT POLLUTANT DETAIL INFORMATION
(Regulated Emissions Units Only - Emissions Limited Pollutants Only)**

Pollutant Detail Information: Pollutant 1 of 1

| |
|--|
| 1. Pollutant Emitted: PM₁₀ , TSP |
| 2. Total Percent Efficiency of Control: 80 % |
| 3. Potential Emissions: PM₁₀_{hourly} = 0.60 lb/hr PM₁₀_{yearly} = 0.94 ton/yr TSP_{hourly} = 1.26 lb/hr TSP_{yearly} = 1.97 ton/yr |
| 4. Synthetically Limited? <input checked="" type="checkbox"/> Yes <input type="checkbox"/> No |
| 5. Range of Estimated Fugitive/Other Emissions: <input type="checkbox"/> 1 <input type="checkbox"/> 2 <input type="checkbox"/> 3 <u> 0 </u> to <u> 0 </u> tons/year |
| 6. Emission Factor: 0.0024 lbs/ton Reference: AP-42 (Table 11.19.2-2 controlled) and footnote © for TSP Emissions |
| 7. Emissions Method Code: <input type="checkbox"/> 0 <input type="checkbox"/> 1 <input type="checkbox"/> 2 <input checked="" type="checkbox"/> 3 <input type="checkbox"/> 4 <input type="checkbox"/> 5 |
| 8. Calculation of Emissions (limit to 600 characters): $PM_{10\text{yearly}} = [(250 \text{ ton/hr})(3120 \text{ hr/yr})(0.0024 \text{ lb/ton})] / (2000 \text{ lb/ton}) = 0.94 \text{ ton/yr}$ $PM_{10\text{hour}} = [(250 \text{ ton/hr})(0.0024 \text{ lb/ton})] = 0.60 \text{ lb/hr}$ $TSP_{\text{yearly}} = [(250 \text{ ton/hr})(3120 \text{ hr/yr})(0.0024 \text{ lb/ton})] (2.1) / (2000 \text{ lb/ton}) = 1.97 \text{ ton/yr}$ $TSP_{\text{hour}} = [(250 \text{ ton/hr})(0.0024 \text{ lb/ton})] (2.1) = 1.26 \text{ lb/hr}$ |
| 9. Pollutant Potential/Estimated Emissions Comment (limit to 200 characters): |

Allowable Emissions (Pollutant identified on front of page)

A.

| | | |
|---|---------|-----------|
| 1. Basis for Allowable Emissions Code: This facility will be subject to 40 CFR Part 60, Subpart 000 rules and regulations. | | |
| 2. Future Effective Date of Allowable Emissions: Initial Visible Emissions Compliance Test | | |
| 3. Requested Allowable Emissions and Units: < 5% Opacity | | |
| 4. Equivalent Allowable Emissions: | lb/hour | tons/year |
| 5. Method of Compliance (limit to 60 characters): Annual EPA Method 9 Compliance Testing. | | |
| 6. Pollutant Allowable Emissions Comment (Desc. of Related Operating Method/Mode) (limit to 200 characters): | | |

B.

| | | |
|---|-------|-----------|
| 1. Basis for Allowable Emissions Code: | | |
| 2. Future Effective Date of Allowable Emissions: | | |
| 3. Requested Allowable Emissions and Units: | | |
| 4. Equivalent Allowable Emissions: | lb/hr | tons/year |
| 5. Method of Compliance (limit to 60 characters): | | |
| 6. Pollutant Allowable Emissions Comment (Desc. of Related Operating Method/Mode) (limit to 200 characters): | | |

**I. VISIBLE EMISSIONS INFORMATION
(Regulated Emissions Units Only)**

Visible Emissions Limitation: Visible Emissions Limitation 1 of 1

| |
|--|
| 1. Visible Emissions Subtype: VE |
| 2. Basis for Allowable Opacity: <input checked="" type="checkbox"/> Rule <input type="checkbox"/> Other |
| 3. Requested Allowable Opacity: Normal Conditions: < 5 % Exceptional Conditions: < 5 % Maximum Period of Excess Opacity Allowed: 0 min/hour |
| 4. Method of Compliance: Annual EPA Method 9 visible emission testing. |
| 5. Visible Emissions Comment (limit to 200 characters): |

Visible Emissions Limitation: Visible Emissions Limitation _____ of _____

| |
|--|
| 1. Visible Emissions Subtype: |
| 2. Basis for Allowable Opacity: <input type="checkbox"/> Rule <input type="checkbox"/> Other |
| 3. Requested Allowable Opacity: Normal Conditions: _____ % Exceptional Conditions: _____ % Maximum Period of Excess Opacity Allowed: _____ min/hour |
| 4. Method of Compliance: |
| 5. Visible Emissions Comment (limit to 200 characters): |

**J. CONTINUOUS MONITOR INFORMATION
(Regulated Emissions Units Only)**

Continuous Monitoring System: Continuous Monitor _____ of _____

| | |
|---|--|
| 1. Parameter Code: NOT APPLICABLE | 2. Pollutant(s): |
| 3. CMS Requirement: | <input type="checkbox"/> Rule <input type="checkbox"/> Other |
| 4. Monitor Information: Manufacturer: Model Number: Serial Number: | |
| 5. Installation Date: | |
| 6. Performance Specification Test Date: | |
| 7. Continuous Monitor Comment (limit to 200 characters): NOT APPLICABLE | |

Continuous Monitoring System: Continuous Monitor _____ of _____

| | |
|--|--|
| 1. Parameter Code: | 2. Pollutant(s): |
| 3. CMS Requirement: | <input type="checkbox"/> Rule <input type="checkbox"/> Other |
| 4. Monitor Information: Manufacturer: Model Number: Serial Number: | |
| 5. Installation Date: | |
| 6. Performance Specification Test Date: | |
| 7. Continuous Monitor Comment (limit to 200 characters): | |

**K. PREVENTION OF SIGNIFICANT DETERIORATION (PSD) INCREMENT
TRACKING INFORMATION
(Regulated and Unregulated Emissions Units)**

PSD Increment Consumption Determination

1. Increment Consuming for Particulate Matter or Sulfur Dioxide?

If the emissions unit addressed in this section emits particulate matter or sulfur dioxide, answer the following series of questions to make a preliminary determination as to whether or not the emissions unit consumes PSD increment for particulate matter or sulfur dioxide. Check the first statement, if any, that applies and skip remaining statements.

-] The emissions unit is undergoing PSD review as part of this application, or has undergone PSD review previously, for particulate matter or sulfur dioxide. If so, emissions unit consumes increment.
-] The facility addressed in this application is classified as an EPA major source pursuant to paragraph (c) of the definition of "major source of air pollution" in Chapter 62-213, F.A.C., and the emissions unit addressed in this section commenced (or will commence) construction after January 6, 1975. If so, baseline emissions are zero, and emissions unit consumes increment.
-] The facility addressed in this application is classified as an EPA major source, and the emissions unit began initial operation after January 6, 1975, but before December 27, 1977. If so, baseline emissions are zero, and emissions unit consumes increment.
-] For any facility, the emissions unit began (or will begin) initial operation after December 27, 1977. If so, baseline emissions are zero, and emissions unit consumes increment.
-] None of the above apply. If so, the baseline emissions of the emissions unit are nonzero. In such case, additional analysis, beyond the scope of this application, is needed to determine whether changes in emissions have occurred (or will occur) after the baseline date that may consume or expand increment.

Emissions Unit Information Section 3 of 9

2. Increment Consuming for Nitrogen Dioxide?

If the emissions unit addressed in this section emits nitrogen oxides, answer the following series of questions to make a preliminary determination as to whether or not the emissions unit consumes PSD increment for nitrogen dioxide. Check first statement, if any, that applies and skip remaining statements.

-] The emissions unit addressed in this section is undergoing PSD review as part of this application, or has undergone PSD review previously, for nitrogen dioxide. If so, emissions unit consumes increment.
-] The facility addressed in this application is classified as an EPA major source pursuant to paragraph (c) of the definition of "major source of air pollution" in Chapter 62-213, F.A.C., and the emissions unit addressed in this section commenced (or will commence) construction after February 8, 1988. If so, baseline emissions are zero, and emissions unit consumes increment.
-] The facility addressed in this application is classified as an EPA major source, and the emissions unit began initial operation after February 8, 1988, but before March 28, 1988. If so, baseline emissions are zero, and emissions unit consumes increment.
-] For any facility, the emissions unit began (or will begin) initial operation after March 28, 1988. If so, baseline emissions are zero, and emissions unit consumes increment.
-] None of the above apply. If so, the baseline emissions of the emissions unit are nonzero. In such case, additional analysis, beyond the scope of this application, is needed to determine whether changes in emissions have occurred (or will occur) after the baseline date that may consume or expand increment.

| | | | |
|---|------------------------------|------------------------------|---|
| 3. Increment Consuming/Expanding Code: | | | |
| PM | <input type="checkbox"/>] C | <input type="checkbox"/>] E | <input checked="" type="checkbox"/>] Unknown |
| SO2 | <input type="checkbox"/>] C | <input type="checkbox"/>] E | <input checked="" type="checkbox"/>] Unknown |
| NO2 | <input type="checkbox"/>] C | <input type="checkbox"/>] E | <input checked="" type="checkbox"/>] Unknown |
| 4. Baseline Emissions: | | | |
| PM ₁₀ / TSP | 0.60 / 1.26 lb/hour | 0.94 / 1.97 tons/year | |
| SO2 | lb/hour | tons/year | |
| NO2 | | tons/year | |
| 5. PSD Comment (limit to 200 characters): | | | |
| | | | |

**L. EMISSIONS UNIT SUPPLEMENTAL INFORMATION
(Regulated Emissions Units Only)**

Supplemental Requirements for All Applications

| |
|---|
| 1. Process Flow Diagram <input checked="" type="checkbox"/> Attached, Document ID: <u> III </u> [] Not Applicable [] Waiver Requested |
| 2. Fuel Analysis or Specification [] Attached, Document ID: _____ [] Not Applicable [] Waiver Requested |
| 3. Detailed Description of Control Equipment <input checked="" type="checkbox"/> Attached, Document ID: <u> V </u> [] Not Applicable [] Waiver Requested |
| 4. Description of Stack Sampling Facilities [] Attached, Document ID: _____ <input checked="" type="checkbox"/> Not Applicable [] Waiver Requested |
| 5. Compliance Test Report [] Attached, Document ID: _____ [] Previously submitted, Date: _____ <input checked="" type="checkbox"/> Not Applicable |
| 6. Procedures for Startup and Shutdown [] Attached, Document ID: _____ <input checked="" type="checkbox"/> Not Applicable |
| 7. Operation and Maintenance Plan <input checked="" type="checkbox"/> Attached, Document ID: <u> VI </u> [] Not Applicable |
| 8. Supplemental Information for Construction Permit Application <input checked="" type="checkbox"/> Attached, Document ID: <u> VII </u> <input checked="" type="checkbox"/> Not Applicable |
| 9. Other Information Required by Rule or Statute [] Attached, Document ID: _____ <input checked="" type="checkbox"/> Not Applicable |

Additional Supplemental Requirements for Category I Applications Only

| |
|--|
| 10. Alternative Methods of Operation <input type="checkbox"/> Attached, Document ID: _____ <input checked="" type="checkbox"/> Not Applicable |
| 11. Alternative Modes of Operation (Emissions Trading) <input type="checkbox"/> Attached, Document ID: _____ <input checked="" type="checkbox"/> Not Applicable |
| 12. Identification of Additional Applicable Requirements <input type="checkbox"/> Attached, Document ID: _____ <input checked="" type="checkbox"/> Not Applicable |
| 13. Compliance Assurance Monitoring Plan <input type="checkbox"/> Attached, Document ID: _____ <input checked="" type="checkbox"/> Not Applicable |
| 14. Acid Rain Application (Hard-copy Required) <input type="checkbox"/> Acid Rain Part - Phase II (Form No. 62-210.900(1)(a)) Attached, Document ID: _____ <input type="checkbox"/> Repowering Extension Plan (Form No. 62-210.900(1)(a)1.) Attached, Document ID: _____ <input type="checkbox"/> New Unit Exemption (Form No. 62-210.900(1)(a)2.) Attached, Document ID: _____ <input type="checkbox"/> Retired Unit Exemption (Form No. 62-210.900(1)(a)3.) Attached, Document ID: _____ <input checked="" type="checkbox"/> Not Applicable |

EMISSIONS ID. NO. 004

**PRE-SCREENER BELT TO
VIBRATING SCREENER**
(DROP POINT)

III. EMISSIONS UNIT INFORMATION

A separate Emissions Unit Information Section (including subsections A through L as required) must be completed for each emissions unit addressed in this Application for Air Permit. If submitting the application form in hard copy, indicate, in the space provided at the top of each page, the number of this Emissions Unit Information Section and the total number of Emissions Unit Information Sections submitted as part of this application. Some of the subsections comprising the Emissions Unit Information Section of the form are intended for regulated emissions units only. Others are intended for both regulated and unregulated emissions units. Each subsection is appropriately marked.

A. TYPE OF EMISSIONS UNIT (Regulated and Unregulated Emissions Units)

Type of Emissions Unit Addressed in This Section

1. Regulated or Unregulated Emissions Unit? Check one:

The emissions unit addressed in this Emissions Unit Information Section is a regulated emissions unit.

The emissions unit addressed in this Emissions Unit Information Section is an unregulated emissions unit.

2. Single Process, Group of Processes, or Fugitive Only? Check one:

This Emissions Unit Information Section addresses, as a single emissions unit, a single process or production unit, or activity, which produces one or more air pollutants and which has at least one definable emission point (stack or vent).

This Emissions Unit Information Section addresses, as a single emissions unit, a group of process or production units and activities which has at least one definable emission point (stack or vent) but may also produce fugitive emissions.

This Emissions Unit Information Section addresses, as a single emissions unit, one or more process or production units and activities which produce fugitive emissions only.

B.

| |
|---|
| 1. Description (limit to 200 characters): |
| |
| 2. Control Device or Method Code: |
| |

C.

| |
|---|
| 1. Description (limit to 200 characters): |
| |
| 2. Control Device or Method Code: |
| |

**C. EMISSIONS UNIT DETAIL INFORMATION
(Regulated Emissions Units Only)**

Emissions Unit Details

| | | |
|-------------------------------------|---|---------|
| 1. Initial Startup Date: | ASAP | |
| 2. Long-term Reserve Shutdown Date: | NOT APPLICABLE | |
| 3. Package Unit: | Pre-Screener Conveying System to Vibrating Screener (Drop Point) | |
| Manufacturer: | Bohringer Machinery Company, Inc. Model No: RC10 | |
| 4. Generator Nameplate Rating: | MW | |
| 5. Incinerator Information: | | |
| | Dwell Temperature: | °F |
| | Dwell Time: | seconds |
| | Incinerator Afterburner Temperature: | °F |

Emissions Unit Operating Capacity

| | |
|--|---|
| 1. Maximum Heat Input Rate: | NONE mmBtu/hr |
| 2. Maximum Incineration Rate: | NA lb/hr tons/day |
| 3. Maximum Process or Throughput Rate: | 250 ton/hr as raw (crushed) reclaimed asphalt or concrete |
| 4. Maximum Production Rate: | 250 ton/hr as reclaimed crushed concrete or asphalt material. (dependent on screen size at the time) |
| 5. Operating Capacity Comment (limit to 200 characters): | |
| <p>The fugitive emissions generated from this drop point where crushed material leaves the Pre-Screener Conveying System and is dropped to the Vibrating Screener is controlled by the water spray bar system on a as needed basis, mounted in the area of the discharge pan / conveying system. This material is still moist enough as to cause little to no fugitive emissions at this drop point. The material that is to be crushed is also is dampened as needed, in it's stockpile as to control emissions in the crushing unit as well as any fugitives generated by prevailing winds.</p> | |

Emissions Unit Operating Schedule

| | | |
|---------------------------------------|----------------------|------------------------|
| Requested Maximum Operating Schedule: | | |
| | 10 hours/day | 6 days/week |
| | 52 weeks/year | 3120 hours/year |

**D. EMISSIONS UNIT REGULATIONS
(Regulated Emissions Units Only)**

Rule Applicability Analysis (Required for Category II applications and Category III applications involving non Title-V sources. See Instructions.)

This facility will be subject to 40 CFR, Part 60, subpart 000 rules and regulations.

List of Applicable Regulations (Required for Category I applications and Category III applications involving Title-V sources. See Instructions.)

| | |
|-----------------------------------|--|
| 62-212.200(56) FAC | |
| 62-296.800 FAC | |
| 40 CFR 60, Subpart 000 | |
| 62-296.310 (2) FAC | |
| 62-297 FAC | |
| 62-297.340 FAC | |
| 62-297.350 FAC | |
| 62-210.350 FAC | |
| Chapter 84-446, Section 3 (12) FS | |
| 62-296.320 FAC | |
| 62-296.310 (3) FAC | |
| 40 CFR 60.11 (d) | |
| 62-4 FAC | |
| 62-210 | |
| | |
| | |
| | |
| | |
| | |
| | |

**E. EMISSION POINT (STACK/VENT) INFORMATION
(Regulated Emissions Units Only)**

Emission Point Description and Type

| | |
|----|--|
| 1. | Identification of Point on Plot Plan or Flow Diagram: Drop Point from Pre-Screener Conveying System to Vibrating Screener (004) |
| 2. | Emission Point Type Code: <input type="checkbox"/> 1 <input type="checkbox"/> 2 <input type="checkbox"/> 3 <input checked="" type="checkbox"/> 4 |
| 8. | Descriptions of Emissions Points Comprising this Emissions Unit for VE Tracking (limit to 100 characters per point): <p style="text-align: center;">Visible Emissions will be determined in the area of drop point, where material exits the Pre-Screener Conveying System and is dropped onto the vibrating screener.</p> |
| 4. | ID Numbers or Descriptions of Emission Units with this Emission Point in Common: <p style="text-align: center;">NOT APPLICABLE</p> |
| 5. | Discharge Type Code: <input type="checkbox"/> D <input checked="" type="checkbox"/> F <input type="checkbox"/> H <input type="checkbox"/> P <input type="checkbox"/> R <input type="checkbox"/> V <input type="checkbox"/> W |
| 6. | Stack Height: NOT APPLICABLE feet |
| 7. | Exit Diameter: feet |
| 8. | Exit Temperature: °F |
| 9. | Actual Volumetric Flow Rate: acfm |

Emissions Unit Information Section 4 of 9

| | |
|---|--------------------|
| 10. Percent Water Vapor : | % |
| 11. Maximum Dry Standard Flow Rate: | dscfm |
| 12. Nonstack Emission Point Height: ~ 10.0 feet | |
| 13. Emission Point UTM Coordinates: <i>(for base/main location of crushing unit only, others not determined as of yet.)</i> | |
| Zone: 17 | East (km): 499.7 |
| | North (km): 3225.5 |
| 14. Emission Point Comment (limit to 200 characters): | |
| Emissions Point will be fugitive only, if any emissions are generated at all. | |

F. SEGMENT (PROCESS/FUEL) INFORMATION
(Regulated and Unregulated Emissions Units)

Segment Description and Rate: Segment 1 of 1

| | |
|---|---|
| <p>1. Segment Description (Process/Fuel Type and Associated Operating Method/Mode) (limit to 500 characters):</p> <p>Bohringer Machinery Company, Inc. – Portable Crushing Unit – Drop Point from Pre-Screener to vibrating screener (Material Handling - Emissions related to vibrating, screening and conveying of reclaimed crushed material).</p> | |
| <p>2. Source Classification Code (SCC): 30502503</p> | |
| <p>3. SCC Units: tons product processed</p> | |
| <p>4. Maximum Hourly Rate: 250 ton/hr</p> | <p>5. Maximum Annual Rate: 780,000 ton/yr</p> |
| <p>6. Estimated Annual Activity Factor: NA</p> | |
| <p>7. Maximum Percent Sulfur: NA</p> | <p>8. Maximum Percent Ash:</p> |
| <p>9. Million Btu per SCC Unit: NA</p> | |
| <p>10. Segment Comment (limit to 200 characters):</p> | |

Segment Description and Rate: Segment _____ of _____

| | |
|---|-------------------------|
| 1. Segment Description (Process/Fuel Type and Associated Operating Method/Mode) (limit to 500 characters): | |
| 2. Source Classification Code (SCC): | |
| 3. SCC Units: | |
| 4. Maximum Hourly Rate: | 5. Maximum Annual Rate: |
| 6. Estimated Annual Activity Factor: | |
| 7. Maximum Percent Sulfur: | 8. Maximum Percent Ash: |
| 9. Million Btu per SCC Unit: | |
| 10. Segment Comment (limit to 200 characters): | |

H. EMISSIONS UNIT POLLUTANT DETAIL INFORMATION
(Regulated Emissions Units Only - Emissions Limited Pollutants Only)

Pollutant Detail Information: **Pollutant 1 of 1**

| |
|--|
| 1. Pollutant Emitted: PM₁₀ , TSP |
| 2. Total Percent Efficiency of Control: 80 % |
| 3. Potential Emissions: PM₁₀_{hourly} = 1.20 lb/hr PM₁₀_{yearly} = 1.87 ton/yr TSP_{hourly} = 2.52 lb/hr TSP_{yearly} = 3.93 ton/yr |
| 4. Synthetically Limited? <input checked="" type="checkbox"/> Yes <input type="checkbox"/> No |
| 5. Range of Estimated Fugitive/Other Emissions: <input type="checkbox"/> 1 <input type="checkbox"/> 2 <input type="checkbox"/> 3 <u>0</u> to <u>0</u> tons/year |
| 6. Emission Factor: 0.0048 lbs/ton Reference: AP-42 (Table 11.19.2-2 controlled) and footnote © for TSP Emissions |
| 7. Emissions Method Code: <input type="checkbox"/> 0 <input type="checkbox"/> 1 <input type="checkbox"/> 2 <input checked="" type="checkbox"/> 3 <input type="checkbox"/> 4 <input type="checkbox"/> 5 |
| 8. Calculation of Emissions (limit to 600 characters): PM₁₀_{yearly} = [(250 ton/hr)(3120 hr/yr)(0.0048 lb/ton)] / (2000 lb/ton) = 1.87 ton/yr PM₁₀_{hour} = [(250 ton/hr)(0.0048 lb/ton)] = 1.20 lb/hr TSP_{yearly} = [(250 ton/hr)(3120 hr/yr)(0.0048 lb/ton)] (2.1) / (2000 lb/ton) = 3.93 ton/yr TSP_{hour} = [(250 ton/hr)(0.0048 lb/ton)] (2.1) = 2.52 lb/hr |
| 9. Pollutant Potential/Estimated Emissions Comment (limit to 200 characters): |

Allowable Emissions (Pollutant identified on front of page)

A.

| |
|---|
| 1. Basis for Allowable Emissions Code: This facility will be subject to 40 CFR Part 60, Subpart 000 rules and regulations. |
| 2. Future Effective Date of Allowable Emissions: Initial Visible Emissions Compliance Test |
| 3. Requested Allowable Emissions and Units: < 5% Opacity |
| 4. Equivalent Allowable Emissions: lb/hour tons/year |
| 5. Method of Compliance (limit to 60 characters): Annual EPA Method 9 Compliance Testing. |
| 6. Pollutant Allowable Emissions Comment (Desc. of Related Operating Method/Mode) (limit to 200 characters): |

B.

| |
|---|
| 1. Basis for Allowable Emissions Code: |
| 2. Future Effective Date of Allowable Emissions: |
| 3. Requested Allowable Emissions and Units: |
| 4. Equivalent Allowable Emissions: lb/hr tons/year |
| 5. Method of Compliance (limit to 60 characters): |
| 6. Pollutant Allowable Emissions Comment (Desc. of Related Operating Method/Mode) (limit to 200 characters): |

**I. VISIBLE EMISSIONS INFORMATION
(Regulated Emissions Units Only)**

Visible Emissions Limitation: Visible Emissions Limitation 1 of 1

| |
|--|
| 1. Visible Emissions Subtype: VE |
| 2. Basis for Allowable Opacity: <input checked="" type="checkbox"/> Rule <input type="checkbox"/> Other |
| 3. Requested Allowable Opacity: Normal Conditions: < 5 % Exceptional Conditions: < 5 % Maximum Period of Excess Opacity Allowed: 0 min/hour |
| 4. Method of Compliance: Annual EPA Method 9 visible emission testing. |
| 5. Visible Emissions Comment (limit to 200 characters): |

Visible Emissions Limitation: Visible Emissions Limitation _____ of _____

| |
|--|
| 1. Visible Emissions Subtype: |
| 2. Basis for Allowable Opacity: <input type="checkbox"/> Rule <input type="checkbox"/> Other |
| 3. Requested Allowable Opacity: Normal Conditions: _____ % Exceptional Conditions: _____ % Maximum Period of Excess Opacity Allowed: _____ min/hour |
| 4. Method of Compliance: |
| 5. Visible Emissions Comment (limit to 200 characters): |

**J. CONTINUOUS MONITOR INFORMATION
(Regulated Emissions Units Only)**

Continuous Monitoring System: Continuous Monitor _____ of _____

| | |
|---|--|
| 1. Parameter Code: NOT APPLICABLE | 2. Pollutant(s): |
| 3. CMS Requirement: | <input type="checkbox"/> Rule <input type="checkbox"/> Other |
| 4. Monitor Information: Manufacturer: Model Number: Serial Number: | |
| 5. Installation Date: | |
| 6. Performance Specification Test Date: | |
| 7. Continuous Monitor Comment (limit to 200 characters): NOT APPLICABLE | |

Continuous Monitoring System: Continuous Monitor _____ of _____

| | |
|--|--|
| 1. Parameter Code: | 2. Pollutant(s): |
| 3. CMS Requirement: | <input type="checkbox"/> Rule <input type="checkbox"/> Other |
| 4. Monitor Information: Manufacturer: Model Number: Serial Number: | |
| 5. Installation Date: | |
| 6. Performance Specification Test Date: | |
| 7. Continuous Monitor Comment (limit to 200 characters): | |

**K. PREVENTION OF SIGNIFICANT DETERIORATION (PSD) INCREMENT
TRACKING INFORMATION
(Regulated and Unregulated Emissions Units)**

PSD Increment Consumption Determination

1. Increment Consuming for Particulate Matter or Sulfur Dioxide?

If the emissions unit addressed in this section emits particulate matter or sulfur dioxide, answer the following series of questions to make a preliminary determination as to whether or not the emissions unit consumes PSD increment for particulate matter or sulfur dioxide. Check the first statement, if any, that applies and skip remaining statements.

-] The emissions unit is undergoing PSD review as part of this application, or has undergone PSD review previously, for particulate matter or sulfur dioxide. If so, emissions unit consumes increment.
-] The facility addressed in this application is classified as an EPA major source pursuant to paragraph (c) of the definition of "major source of air pollution" in Chapter 62-213, F.A.C., and the emissions unit addressed in this section commenced (or will commence) construction after January 6, 1975. If so, baseline emissions are zero, and emissions unit consumes increment.
-] The facility addressed in this application is classified as an EPA major source, and the emissions unit began initial operation after January 6, 1975, but before December 27, 1977. If so, baseline emissions are zero, and emissions unit consumes increment.
-] For any facility, the emissions unit began (or will begin) initial operation after December 27, 1977. If so, baseline emissions are zero, and emissions unit consumes increment.
-] None of the above apply. If so, the baseline emissions of the emissions unit are nonzero. In such case, additional analysis, beyond the scope of this application, is needed to determine whether changes in emissions have occurred (or will occur) after the baseline date that may consume or expand increment.

Emissions Unit Information Section 4 of 9

2. Increment Consuming for Nitrogen Dioxide?

If the emissions unit addressed in this section emits nitrogen oxides, answer the following series of questions to make a preliminary determination as to whether or not the emissions unit consumes PSD increment for nitrogen dioxide. Check first statement, if any, that applies and skip remaining statements.

-] The emissions unit addressed in this section is undergoing PSD review as part of this application, or has undergone PSD review previously, for nitrogen dioxide. If so, emissions unit consumes increment.
-] The facility addressed in this application is classified as an EPA major source pursuant to paragraph (c) of the definition of "major source of air pollution" in Chapter 62-213, F.A.C., and the emissions unit addressed in this section commenced (or will commence) construction after February 8, 1988. If so, baseline emissions are zero, and emissions unit consumes increment.
-] The facility addressed in this application is classified as an EPA major source, and the emissions unit began initial operation after February 8, 1988, but before March 28, 1988. If so, baseline emissions are zero, and emissions unit consumes increment.
-] For any facility, the emissions unit began (or will begin) initial operation after March 28, 1988. If so, baseline emissions are zero, and emissions unit consumes increment.
-] None of the above apply. If so, the baseline emissions of the emissions unit are nonzero. In such case, additional analysis, beyond the scope of this application, is needed to determine whether changes in emissions have occurred (or will occur) after the baseline date that may consume or expand increment.

| | | | |
|---|------------------------------|------------------------------|--------------|
| 3. Increment Consuming/Expanding Code: | | | |
| PM | <input type="checkbox"/>] C | <input type="checkbox"/>] E | [X] Unknown |
| SO2 | <input type="checkbox"/>] C | <input type="checkbox"/>] E | [X] Unknown |
| NO2 | <input type="checkbox"/>] C | <input type="checkbox"/>] E | [X] Unknown |
| 4. Baseline Emissions: | | | |
| PM ₁₀ /TSP | 1.20 / 2.52 lb/hour | 1.87 / 3.93 tons/year | |
| SO2 | lb/hour | tons/year | |
| NO2 | | tons/year | |
| 5. PSD Comment (limit to 200 characters): | | | |
| | | | |

**L. EMISSIONS UNIT SUPPLEMENTAL INFORMATION
(Regulated Emissions Units Only)**

Supplemental Requirements for All Applications

| |
|---|
| 1. Process Flow Diagram <input checked="" type="checkbox"/> Attached, Document ID: <u>III</u> [] Not Applicable [] Waiver Requested |
| 2. Fuel Analysis or Specification [] Attached, Document ID: _____ [] Not Applicable [] Waiver Requested |
| 3. Detailed Description of Control Equipment <input checked="" type="checkbox"/> Attached, Document ID: <u>V</u> [] Not Applicable [] Waiver Requested |
| 4. Description of Stack Sampling Facilities [] Attached, Document ID: _____ <input checked="" type="checkbox"/> Not Applicable [] Waiver Requested |
| 5. Compliance Test Report [] Attached, Document ID: _____ [] Previously submitted, Date: _____ <input checked="" type="checkbox"/> Not Applicable |
| 6. Procedures for Startup and Shutdown [] Attached, Document ID: _____ <input checked="" type="checkbox"/> Not Applicable |
| 7. Operation and Maintenance Plan <input checked="" type="checkbox"/> Attached, Document ID: <u>VI</u> [] Not Applicable |
| 8. Supplemental Information for Construction Permit Application <input checked="" type="checkbox"/> Attached, Document ID: <u>VII</u> <input checked="" type="checkbox"/> Not Applicable |
| 9. Other Information Required by Rule or Statute [] Attached, Document ID: _____ <input checked="" type="checkbox"/> Not Applicable |

Additional Supplemental Requirements for Category I Applications Only

| |
|--|
| 10. Alternative Methods of Operation <input type="checkbox"/> Attached, Document ID: _____ <input checked="" type="checkbox"/> Not Applicable |
| 11. Alternative Modes of Operation (Emissions Trading) <input type="checkbox"/> Attached, Document ID: _____ <input checked="" type="checkbox"/> Not Applicable |
| 12. Identification of Additional Applicable Requirements <input type="checkbox"/> Attached, Document ID: _____ <input checked="" type="checkbox"/> Not Applicable |
| 13. Compliance Assurance Monitoring Plan <input type="checkbox"/> Attached, Document ID: _____ <input checked="" type="checkbox"/> Not Applicable |
| 14. Acid Rain Application (Hard-copy Required) <input type="checkbox"/> Acid Rain Part - Phase II (Form No. 62-210.900(1)(a)) Attached, Document ID: _____ <input type="checkbox"/> Repowering Extension Plan (Form No. 62-210.900(1)(a)1.) Attached, Document ID: _____ <input type="checkbox"/> New Unit Exemption (Form No. 62-210.900(1)(a)2.) Attached, Document ID: _____ <input type="checkbox"/> Retired Unit Exemption (Form No. 62-210.900(1)(a)3.) Attached, Document ID: _____ <input checked="" type="checkbox"/> Not Applicable |

EMISSIONS ID. NO. 005

**VIBRATING SCREENER to
SCREENED MATERIAL DISCHARGE BELT**
(DROP POINT)

III. EMISSIONS UNIT INFORMATION

A separate Emissions Unit Information Section (including subsections A through L as required) must be completed for each emissions unit addressed in this Application for Air Permit. If submitting the application form in hard copy, indicate, in the space provided at the top of each page, the number of this Emissions Unit Information Section and the total number of Emissions Unit Information Sections submitted as part of this application. Some of the subsections comprising the Emissions Unit Information Section of the form are intended for regulated emissions units only. Others are intended for both regulated and unregulated emissions units. Each subsection is appropriately marked.

A. TYPE OF EMISSIONS UNIT (Regulated and Unregulated Emissions Units)

Type of Emissions Unit Addressed in This Section

1. Regulated or Unregulated Emissions Unit? Check one:

The emissions unit addressed in this Emissions Unit Information Section is a regulated emissions unit.

The emissions unit addressed in this Emissions Unit Information Section is an unregulated emissions unit.

2. Single Process, Group of Processes, or Fugitive Only? Check one:

This Emissions Unit Information Section addresses, as a single emissions unit, a single process or production unit, or activity, which produces one or more air pollutants and which has at least one definable emission point (stack or vent).

This Emissions Unit Information Section addresses, as a single emissions unit, a group of process or production units and activities which has at least one definable emission point (stack or vent) but may also produce fugitive emissions.

This Emissions Unit Information Section addresses, as a single emissions unit, one or more process or production units and activities which produce fugitive emissions only.

**B. GENERAL EMISSIONS UNIT INFORMATION
(Regulated and Unregulated Emissions Units)**

Emissions Unit Description and Status

| | | |
|--|--------------------------------------|--|
| 1. Description of Emissions Unit Addressed in This Section (limit to 60 characters): Bohringer Machinery Company, Inc. – Vibrating Screener to Screener Discharge Conveying System (drop point from Vibrating Screener to Screener Discharge Conveying System) | | |
| 2. Emissions Unit Identification Number: [] No Corresponding ID [X] Unknown | | |
| 3. Emissions Unit Status Code: Construction | 4. Acid Rain Unit? [] Yes [X] No | 5. Emissions Unit Major Group SIC Code: 14 |
| 6. Emissions Unit Comment (limit to 500 characters): | | |

Emissions Unit Control Equipment

A.

| |
|--|
| 9. Description (limit to 200 characters): The fugitive emissions generated from this drop point where crushed material leaves the vibrating screener and is dropped onto the screened material discharge belt are controlled by the water spray bar system on a as needed basis, mounted in the area of the discharge pan / conveying system. This material is still moist enough as to cause little to no fugitive emissions at this drop point. This material is still moist from previous spray systems and is also dampened before it leaves the belt and drops to it's stockpile. |
| 2. Control Device or Method Code: 061, 099 |

B.

| |
|---|
| 1. Description (limit to 200 characters): |
| |
| 2. Control Device or Method Code: |

C.

| |
|---|
| 1. Description (limit to 200 characters): |
| |
| 2. Control Device or Method Code: |

**C. EMISSIONS UNIT DETAIL INFORMATION
(Regulated Emissions Units Only)**

Emissions Unit Details

| |
|---|
| 1. Initial Startup Date: ASAP |
| 2. Long-term Reserve Shutdown Date: NOT APPLICABLE |
| 3. Package Unit: Vibrating Screener to Screened Material Discharge Belt (Drop Point) Manufacturer: Bohringer Machinery Company, Inc. Model No: RC10 |
| 4. Generator Nameplate Rating: MW |
| 5. Incinerator Information: Dwell Temperature: °F Dwell Time: seconds Incinerator Afterburner Temperature: °F |

Emissions Unit Operating Capacity

| |
|---|
| 1. Maximum Heat Input Rate: NONE mmBtu/hr |
| 2. Maximum Incineration Rate: NA lb/hr tons/day |
| 3. Maximum Process or Throughput Rate: 250 ton/hr as raw (crushed) reclaimed asphalt or concrete |
| 4. Maximum Production Rate: 250 ton/hr as reclaimed crushed concrete or asphalt material. (dependent on screen size at the time) |
| 5. Operating Capacity Comment (limit to 200 characters): The fugitive emissions generated from this drop point where crushed material leaves the vibrating screener and is dropped onto the screened material discharge belt are controlled by the water spray bar system on a as needed basis, mounted in the area of the discharge pan / conveying system. This material is still moist enough as to cause little to no fugitive emissions at this drop point. This material is still moist from previous spray systems and is also dampened before it leaves the belt and drops to it's stockpile. |

Emissions Unit Operating Schedule

| | | |
|---------------------------------------|-----------------|--|
| Requested Maximum Operating Schedule: | | |
| 10 hours/day | 6 days/week | |
| 52 weeks/year | 3120 hours/year | |

**D. EMISSIONS UNIT REGULATIONS
(Regulated Emissions Units Only)**

Rule Applicability Analysis (Required for Category II applications and Category III applications involving non Title-V sources. See Instructions.)

This facility will be subject to 40 CFR, Part 60, subpart 000 rules and regulations.

List of Applicable Regulations (Required for Category I applications and Category III applications involving Title-V sources. See Instructions.)

| | |
|--|--|
| 62-212.200(56) FAC | |
| 62-296.800 FAC | |
| 40 CFR 60, Subpart 000 | |
| 62-296.310 (2) FAC | |
| 62-297 FAC | |
| 62-297.340 FAC | |
| 62-297.350 FAC | |
| 62-210.350 FAC | |
| Chapter 84-446, Section 3 (12) FS | |
| 62-296.320 FAC | |
| 62-296.310 (3) FAC | |
| 40 CFR 60.11 (d) | |
| 62-4 FAC | |
| 62-210 | |
| | |
| | |
| | |
| | |
| | |
| | |

**E. EMISSION POINT (STACK/VENT) INFORMATION
(Regulated Emissions Units Only)**

Emission Point Description and Type

| |
|---|
| 1. Identification of Point on Plot Plan or Flow Diagram: Vibrating Screener Drop Point to Screened Material Discharge Belt (005) |
| 2. Emission Point Type Code: <input type="checkbox"/> 1 <input type="checkbox"/> 2 <input type="checkbox"/> 3 <input checked="" type="checkbox"/> 4 |
| 10. Descriptions of Emissions Points Comprising this Emissions Unit for VE Tracking (limit to 100 characters per point): <p align="center">Visible Emissions will be determined in the area of drop point, where material exits Vibrating Screener and falls onto Screened Material Discharge Belt.</p> |
| 4. ID Numbers or Descriptions of Emission Units with this Emission Point in Common: <p align="center">NOT APPLICABLE</p> |
| 5. Discharge Type Code: <input type="checkbox"/> D <input checked="" type="checkbox"/> F <input type="checkbox"/> H <input type="checkbox"/> P <input type="checkbox"/> R <input type="checkbox"/> V <input type="checkbox"/> W |
| 6. Stack Height: NOT APPLICABLE feet |
| 7. Exit Diameter: feet |
| 8. Exit Temperature: °F |
| 9. Actual Volumetric Flow Rate: acfm |

Emissions Unit Information Section 5 of 9

| | |
|---|-------|
| 10. Percent Water Vapor : | % |
| 11. Maximum Dry Standard Flow Rate: | dscfm |
| 12. Nonstack Emission Point Height: ~ 0.0 to 20.0 feet | |
| 13. Emission Point UTM Coordinates: <i>(for base/main location of crushing unit only, others not determined as of yet.)</i> Zone: 17 East (km): 499.7 North (km): 3225.2 | |
| 14. Emission Point Comment (limit to 200 characters): Emissions Point will be fugitive only, if any emissions are generated at all. | |

**F. SEGMENT (PROCESS/FUEL) INFORMATION
(Regulated and Unregulated Emissions Units)**

Segment Description and Rate: Segment 1 of 1

| | |
|--|--|
| 1. Segment Description (Process/Fuel Type and Associated Operating Method/Mode) (limit to 500 characters): Bohringer Machinery Company, Inc. – Portable Crushing Unit – Vibrating Screener to Screened Material Discharge Belt. (Material Handling - Emissions related to conveying of reclaimed crushed material). | |
| 2. Source Classification Code (SCC): 30502503 | |
| 3. SCC Units: tons product processed | |
| 4. Maximum Hourly Rate: 250 ton/hr | 5. Maximum Annual Rate: 780,000 ton/yr |
| 6. Estimated Annual Activity Factor: NA | |
| 7. Maximum Percent Sulfur: NA | 8. Maximum Percent Ash: |
| 9. Million Btu per SCC Unit: NA | |
| 10. Segment Comment (limit to 200 characters): | |

Segment Description and Rate: Segment of

| | |
|---|-------------------------|
| 1. Segment Description (Process/Fuel Type and Associated Operating Method/Mode) (limit to 500 characters): | |
| 2. Source Classification Code (SCC): | |
| 3. SCC Units: | |
| 4. Maximum Hourly Rate: | 5. Maximum Annual Rate: |
| 6. Estimated Annual Activity Factor: | |
| 7. Maximum Percent Sulfur: | 8. Maximum Percent Ash: |
| 9. Million Btu per SCC Unit: | |
| 10. Segment Comment (limit to 200 characters): | |

**H. EMISSIONS UNIT POLLUTANT DETAIL INFORMATION
(Regulated Emissions Units Only - Emissions Limited Pollutants Only)**

Pollutant Detail Information: Pollutant 1 of 1

| |
|--|
| 1. Pollutant Emitted: PM₁₀ , TSP |
| 2. Total Percent Efficiency of Control: 80 % |
| 3. Potential Emissions: PM₁₀_{hourly} = 0.96 lb/hr PM₁₀_{yearly} = 1.50 ton/yr TSP_{hourly} = 2.02 lb/hr TSP_{yearly} = 3.14 ton/yr |
| 4. Synthetically Limited? <input checked="" type="checkbox"/> Yes <input type="checkbox"/> No |
| 5. Range of Estimated Fugitive/Other Emissions: <input type="checkbox"/> 1 <input type="checkbox"/> 2 <input type="checkbox"/> 3 <u> 0 </u> to <u> 0 </u> tons/year |
| 6. Emission Factor: 0.0048 lbs/ton Reference: AP-42 (Table 11.19.2-2 controlled) and footnote © for TSP Emissions |
| 7. Emissions Method Code: <input type="checkbox"/> 0 <input type="checkbox"/> 1 <input type="checkbox"/> 2 <input checked="" type="checkbox"/> 3 <input type="checkbox"/> 4 <input type="checkbox"/> 5 |
| 8. Calculation of Emissions (limit to 600 characters): PM₁₀_{yearly} = [(250 ton/hr)(3120 hr/yr)(0.0048 lb/ton)] / (2000 lb/ton) = 1.87 ton/yr PM₁₀_{hour} = [(250 ton/hr)(0.0048 lb/ton)] = 1.20 lb/hr TSP_{yearly} = [(250 ton/hr)(3120 hr/yr)(0.0048 lb/ton)] (2.1) / (2000 lb/ton) = 3.93 ton/yr TSP_{hour} = [(250 ton/hr)(0.0048 lb/ton)] (2.1) = 2.52 lb/hr |
| 9. Pollutant Potential/Estimated Emissions Comment (limit to 200 characters): |

Allowable Emissions (Pollutant identified on front of page)

A.

| | | |
|---|---------|-----------|
| 1. Basis for Allowable Emissions Code: This facility will be subject to 40 CFR Part 60, Subpart 000 rules and regulations. | | |
| 2. Future Effective Date of Allowable Emissions: Initial Visible Emissions Compliance Test | | |
| 3. Requested Allowable Emissions and Units: < 5% Opacity | | |
| 4. Equivalent Allowable Emissions: | lb/hour | tons/year |
| 5. Method of Compliance (limit to 60 characters): Annual EPA Method 9 Compliance Testing. | | |
| 6. Pollutant Allowable Emissions Comment (Desc. Of Related Operating Method/Mode) (limit to 200 characters): | | |

B.

| | | |
|---|-------|-----------|
| 1. Basis for Allowable Emissions Code: | | |
| 2. Future Effective Date of Allowable Emissions: | | |
| 3. Requested Allowable Emissions and Units: | | |
| 4. Equivalent Allowable Emissions: | lb/hr | tons/year |
| 5. Method of Compliance (limit to 60 characters): | | |
| 6. Pollutant Allowable Emissions Comment (Desc. Of Related Operating Method/Mode) (limit to 200 characters): | | |

**I. VISIBLE EMISSIONS INFORMATION
(Regulated Emissions Units Only)**

Visible Emissions Limitation: Visible Emissions Limitation 1 of 1

| |
|--|
| 1. Visible Emissions Subtype: VE |
| 2. Basis for Allowable Opacity: <input checked="" type="checkbox"/> Rule <input type="checkbox"/> Other |
| 3. Requested Allowable Opacity: Normal Conditions: < 5 % Exceptional Conditions: < 5 % Maximum Period of Excess Opacity Allowed: 0 min/hour |
| 4. Method of Compliance: Annual EPA Method 9 visible emission testing. |
| 5. Visible Emissions Comment (limit to 200 characters): |

Visible Emissions Limitation: Visible Emissions Limitation _____ of _____

| |
|--|
| 1. Visible Emissions Subtype: |
| 2. Basis for Allowable Opacity: <input type="checkbox"/> Rule <input type="checkbox"/> Other |
| 3. Requested Allowable Opacity: Normal Conditions: _____ % Exceptional Conditions: _____ % Maximum Period of Excess Opacity Allowed: _____ min/hour |
| 4. Method of Compliance: |
| 5. Visible Emissions Comment (limit to 200 characters): |

**K. PREVENTION OF SIGNIFICANT DETERIORATION (PSD) INCREMENT
TRACKING INFORMATION
(Regulated and Unregulated Emissions Units)**

PSD Increment Consumption Determination

1. Increment Consuming for Particulate Matter or Sulfur Dioxide?

If the emissions unit addressed in this section emits particulate matter or sulfur dioxide, answer the following series of questions to make a preliminary determination as to whether or not the emissions unit consumes PSD increment for particulate matter or sulfur dioxide. Check the first statement, if any, that applies and skip remaining statements.

-] The emissions unit is undergoing PSD review as part of this application, or has undergone PSD review previously, for particulate matter or sulfur dioxide. If so, emissions unit consumes increment.
-] The facility addressed in this application is classified as an EPA major source pursuant to paragraph (c) of the definition of "major source of air pollution" in Chapter 62-213, F.A.C., and the emissions unit addressed in this section commenced (or will commence) construction after January 6, 1975. If so, baseline emissions are zero, and emissions unit consumes increment.
-] The facility addressed in this application is classified as an EPA major source, and the emissions unit began initial operation after January 6, 1975, but before December 27, 1977. If so, baseline emissions are zero, and emissions unit consumes increment.
-] For any facility, the emissions unit began (or will begin) initial operation after December 27, 1977. If so, baseline emissions are zero, and emissions unit consumes increment.
-] None of the above apply. If so, the baseline emissions of the emissions unit are nonzero. In such case, additional analysis, beyond the scope of this application, is needed to determine whether changes in emissions have occurred (or will occur) after the baseline date that may consume or expand increment.

2. Increment Consuming for Nitrogen Dioxide?

If the emissions unit addressed in this section emits nitrogen oxides, answer the following series of questions to make a preliminary determination as to whether or not the emissions unit consumes PSD increment for nitrogen dioxide. Check first statement, if any, that applies and skip remaining statements.

-] The emissions unit addressed in this section is undergoing PSD review as part of this application, or has undergone PSD review previously, for nitrogen dioxide. If so, emissions unit consumes increment.
-] The facility addressed in this application is classified as an EPA major source pursuant to paragraph (c) of the definition of "major source of air pollution" in Chapter 62-213, F.A.C., and the emissions unit addressed in this section commenced (or will commence) construction after February 8, 1988. If so, baseline emissions are zero, and emissions unit consumes increment.
-] The facility addressed in this application is classified as an EPA major source, and the emissions unit began initial operation after February 8, 1988, but before March 28, 1988. If so, baseline emissions are zero, and emissions unit consumes increment.
-] For any facility, the emissions unit began (or will begin) initial operation after March 28, 1988. If so, baseline emissions are zero, and emissions unit consumes increment.
-] None of the above apply. If so, the baseline emissions of the emissions unit are nonzero. In such case, additional analysis, beyond the scope of this application, is needed to determine whether changes in emissions have occurred (or will occur) after the baseline date that may consume or expand increment.

| | | | |
|---|------------------------------|------------------------------|---|
| 3. Increment Consuming/Expanding Code: | | | |
| PM | <input type="checkbox"/>] C | <input type="checkbox"/>] E | <input checked="" type="checkbox"/>] Unknown |
| SO2 | <input type="checkbox"/>] C | <input type="checkbox"/>] E | <input checked="" type="checkbox"/>] Unknown |
| NO2 | <input type="checkbox"/>] C | <input type="checkbox"/>] E | <input checked="" type="checkbox"/>] Unknown |
| 4. Baseline Emissions: | | | |
| PM ₁₀ / TSP | 1.20/2.52 lb/hour | 1.87 / 3.93 tons/year | |
| SO2 | lb/hour | tons/year | |
| NO2 | | tons/year | |
| 5. PSD Comment (limit to 200 characters): | | | |
| | | | |

**L. EMISSIONS UNIT SUPPLEMENTAL INFORMATION
(Regulated Emissions Units Only)**

Supplemental Requirements for All Applications

| |
|---|
| 1. Process Flow Diagram <input checked="" type="checkbox"/> Attached, Document ID: <u>III</u> [] Not Applicable [] Waiver Requested |
| 2. Fuel Analysis or Specification [] Attached, Document ID: _____ [] Not Applicable [] Waiver Requested |
| 3. Detailed Description of Control Equipment <input checked="" type="checkbox"/> Attached, Document ID: <u>V</u> [] Not Applicable [] Waiver Requested |
| 4. Description of Stack Sampling Facilities [] Attached, Document ID: _____ <input checked="" type="checkbox"/> Not Applicable [] Waiver Requested |
| 5. Compliance Test Report [] Attached, Document ID: _____ [] Previously submitted, Date: _____ <input checked="" type="checkbox"/> Not Applicable |
| 6. Procedures for Startup and Shutdown [] Attached, Document ID: _____ <input checked="" type="checkbox"/> Not Applicable |
| 7. Operation and Maintenance Plan <input checked="" type="checkbox"/> Attached, Document ID: <u>VI</u> [] Not Applicable |
| 8. Supplemental Information for Construction Permit Application <input checked="" type="checkbox"/> Attached, Document ID: <u>VII</u> <input checked="" type="checkbox"/> Not Applicable |
| 9. Other Information Required by Rule or Statute [] Attached, Document ID: _____ <input checked="" type="checkbox"/> Not Applicable |

Additional Supplemental Requirements for Category I Applications Only

| |
|--|
| 10. Alternative Methods of Operation <input type="checkbox"/> Attached, Document ID: _____ <input checked="" type="checkbox"/> Not Applicable |
| 11. Alternative Modes of Operation (Emissions Trading) <input type="checkbox"/> Attached, Document ID: _____ <input checked="" type="checkbox"/> Not Applicable |
| 12. Identification of Additional Applicable Requirements <input type="checkbox"/> Attached, Document ID: _____ <input checked="" type="checkbox"/> Not Applicable |
| 13. Compliance Assurance Monitoring Plan <input type="checkbox"/> Attached, Document ID: _____ <input checked="" type="checkbox"/> Not Applicable |
| 14. Acid Rain Application (Hard-copy Required) <input type="checkbox"/> Acid Rain Part - Phase II (Form No. 62-210.900(1)(a)) Attached, Document ID: _____ <input type="checkbox"/> Repowering Extension Plan (Form No. 62-210.900(1)(a)1.) Attached, Document ID: _____ <input type="checkbox"/> New Unit Exemption (Form No. 62-210.900(1)(a)2.) Attached, Document ID: _____ <input type="checkbox"/> Retired Unit Exemption (Form No. 62-210.900(1)(a)3.) Attached, Document ID: _____ <input checked="" type="checkbox"/> Not Applicable |

EMISSIONS ID. NO. 006

**SCREENED MATERIAL DISCHARGE BELT to
RADIAL STACKER BELT No. 1**

(DROP POINT)

III. EMISSIONS UNIT INFORMATION

A separate Emissions Unit Information Section (including subsections A through L as required) must be completed for each emissions unit addressed in this Application for Air Permit. If submitting the application form in hard copy, indicate, in the space provided at the top of each page, the number of this Emissions Unit Information Section and the total number of Emissions Unit Information Sections submitted as part of this application. Some of the subsections comprising the Emissions Unit Information Section of the form are intended for regulated emissions units only. Others are intended for both regulated and unregulated emissions units. Each subsection is appropriately marked.

A. TYPE OF EMISSIONS UNIT (Regulated and Unregulated Emissions Units)

Type of Emissions Unit Addressed in This Section

1. Regulated or Unregulated Emissions Unit? Check one:

The emissions unit addressed in this Emissions Unit Information Section is a regulated emissions unit.

The emissions unit addressed in this Emissions Unit Information Section is an unregulated emissions unit.

2. Single Process, Group of Processes, or Fugitive Only? Check one:

This Emissions Unit Information Section addresses, as a single emissions unit, a single process or production unit, or activity, which produces one or more air pollutants and which has at least one definable emission point (stack or vent).

This Emissions Unit Information Section addresses, as a single emissions unit, a group of process or production units and activities which has at least one definable emission point (stack or vent) but may also produce fugitive emissions.

This Emissions Unit Information Section addresses, as a single emissions unit, one or more process or production units and activities which produce fugitive emissions only.

**B. GENERAL EMISSIONS UNIT INFORMATION
(Regulated and Unregulated Emissions Units)**

Emissions Unit Description and Status

| | | |
|--|--------------------------------------|--|
| 1. Description of Emissions Unit Addressed in This Section (limit to 60 characters): Bohringer Machinery Company, Inc. – Crushing Unit - Drop Point from Screened Material Discharge Belt to Radial Stacker Belt No.1 (60'). (Material Handling, Fugitive Emissions Generated if any at all are generated at the drop point between the two belts) | | |
| 2. Emissions Unit Identification Number: [] No Corresponding ID [X] Unknown | | |
| 3. Emissions Unit Status Code: Construction | 4. Acid Rain Unit? [] Yes [X] No | 5. Emissions Unit Major Group SIC Code: 14 |
| 6. Emissions Unit Comment (limit to 500 characters): | | |

Emissions Unit Control Equipment

A.

| |
|---|
| 11. Description (limit to 200 characters): The fugitive emissions generated from this drop point where crushed material leaves the screened material discharge belt and is dropped to Radial Stacker Belt No.1 (60') are controlled as needed by a water spray bar system mounted at the discharge hopper in the area under the crusher. This material is still moist from previous spray systems and is also dampened before it leaves the belt and drops to it's stockpile. |
| 2. Control Device or Method Code: 061, 099 |

B.

| |
|---|
| 1. Description (limit to 200 characters): |
| |
| 2. Control Device or Method Code: |
| |

C.

| |
|---|
| 1. Description (limit to 200 characters): |
| |
| 2. Control Device or Method Code: |
| |

**C. EMISSIONS UNIT DETAIL INFORMATION
(Regulated Emissions Units Only)**

Emissions Unit Details

| |
|--|
| 1. Initial Startup Date: ASAP |
| 2. Long-term Reserve Shutdown Date: NOT APPLICABLE |
| 3. Package Unit: Screened Material Discharge Belt (Drop Point) to Radial Stacker Belt No.1 (60') Manufacturer: Bohringer Machinery Company, Inc. Model No: RC10 |
| 4. Generator Nameplate Rating: MW |
| 5. Incinerator Information: <div style="display: flex; justify-content: space-between; margin-left: 100px;"> Dwell Temperature: °F </div> <div style="display: flex; justify-content: space-between; margin-left: 100px;"> Dwell Time: seconds </div> <div style="display: flex; justify-content: space-between; margin-left: 100px;"> Incinerator Afterburner Temperature: °F </div> |

Emissions Unit Operating Capacity

| |
|--|
| 1. Maximum Heat Input Rate: NONE mmBtu/hr |
| 2. Maximum Incineration Rate: NA lb/hr tons/day |
| 3. Maximum Process or Throughput Rate: 250 ton/hr as raw (crushed) reclaimed asphalt or concrete |
| 4. Maximum Production Rate: 25 ton/hr as reclaimed crushed concrete or asphalt material. (dependent on screen size at the time) |
| 5. Operating Capacity Comment (limit to 200 characters): This material is still moist from previous spray systems as needed. |

Emissions Unit Operating Schedule

| | | |
|---------------------------------------|-----------------|--|
| Requested Maximum Operating Schedule: | | |
| 10 hours/day | 6 days/week | |
| 52 weeks/year | 3120 hours/year | |

**D. EMISSIONS UNIT REGULATIONS
(Regulated Emissions Units Only)**

Rule Applicability Analysis (Required for Category II applications and Category III applications involving non Title-V sources. See Instructions.)

This facility will be subject to 40 CFR, Part 60, subpart 000 rules and regulations.

List of Applicable Regulations (Required for Category I applications and Category III applications involving Title-V sources. See Instructions.)

| | |
|--|--|
| 62-212.200(56) FAC | |
| 62-296.800 FAC | |
| 40 CFR 60, Subpart 000 | |
| 62-296.310 (2) FAC | |
| 62-297 FAC | |
| 62-297.340 FAC | |
| 62-297.350 FAC | |
| 62-210.350 FAC | |
| Chapter 84-446, Section 3 (12) FS | |
| 62-296.320 FAC | |
| 62-296.310 (3) FAC | |
| 40 CFR 60.11 (d) | |
| 62-4 FAC | |
| 62-210 | |
| | |
| | |
| | |
| | |
| | |
| | |
| | |

**E. EMISSION POINT (STACK/VENT) INFORMATION
(Regulated Emissions Units Only)**

Emission Point Description and Type

| |
|---|
| 1. Identification of Point on Plot Plan or Flow Diagram: Screened Material Discharge Belt (drop point) to Radial Stacker No.1 (006) |
| 2. Emission Point Type Code: <input type="checkbox"/> 1 <input type="checkbox"/> 2 <input type="checkbox"/> 3 <input checked="" type="checkbox"/> 4 |
| 12. Descriptions of Emissions Points Comprising this Emissions Unit for VE Tracking (limit to 100 characters per point): Visible Emissions will be determined in the area of drop point, where material drops from the screened material discharge belt and fall onto Radial Stacker Belt No.1 (60'). |
| 4. ID Numbers or Descriptions of Emission Units with this Emission Point in Common: NOT APPLICABLE |
| 5. Discharge Type Code: <input type="checkbox"/> D <input checked="" type="checkbox"/> F <input type="checkbox"/> H <input type="checkbox"/> P <input type="checkbox"/> R <input type="checkbox"/> V <input type="checkbox"/> W |
| 6. Stack Height: NOT APPLICABLE feet |
| 7. Exit Diameter: feet |
| 8. Exit Temperature: °F |
| 9. Actual Volumetric Flow Rate: acfm |

Emissions Unit Information Section 6 of 9

| | |
|---|-------|
| 10. Percent Water Vapor : | % |
| 11. Maximum Dry Standard Flow Rate: | dscfm |
| 12. Nonstack Emission Point Height: ~ 0.0 to 20.0 feet | |
| 13. Emission Point UTM Coordinates: <i>(for base/main location of crushing unit only, others not determined as of yet.)</i> Zone: 17 East (km): 499.7 North (km): 3225.5 | |
| 14. Emission Point Comment (limit to 200 characters): Emissions Point will be fugitive only, if any emissions are generated at all. | |

**F. SEGMENT (PROCESS/FUEL) INFORMATION
(Regulated and Unregulated Emissions Units)**

Segment Description and Rate: Segment 1 of 1

| | |
|---|--|
| <p>1. Segment Description (Process/Fuel Type and Associated Operating Method/Mode) (limit to 500 characters):</p> <p>Bohringer Machinery Company, Inc. – Portable Crushing Unit – screened material discharge belt drop point to Radial Stacker Belt No.1. (Material Handling - Emissions related to conveying of crushed material).</p> | |
| <p>2. Source Classification Code (SCC): 30502511</p> | |
| <p>3. SCC Units: tons product processed</p> | |
| <p>4. Maximum Hourly Rate: 250 ton/hr</p> | <p>5. Maximum Annual Rate: 780,000 ton/yr</p> |
| <p>6. Estimated Annual Activity Factor: NA</p> | |
| <p>7. Maximum Percent Sulfur: NA</p> | <p>8. Maximum Percent Ash:</p> |
| <p>9. Million Btu per SCC Unit: NA</p> | |
| <p>10. Segment Comment (limit to 200 characters):</p> | |

Segment Description and Rate: Segment of

| | |
|---|-------------------------|
| 1. Segment Description (Process/Fuel Type and Associated Operating Method/Mode) (limit to 500 characters): | |
| 2. Source Classification Code (SCC): | |
| 3. SCC Units: | |
| 4. Maximum Hourly Rate: | 5. Maximum Annual Rate: |
| 6. Estimated Annual Activity Factor: | |
| 7. Maximum Percent Sulfur: | 8. Maximum Percent Ash: |
| 9. Million Btu per SCC Unit: | |
| 10. Segment Comment (limit to 200 characters): | |

**H. EMISSIONS UNIT POLLUTANT DETAIL INFORMATION
(Regulated Emissions Units Only - Emissions Limited Pollutants Only)**

Pollutant Detail Information: Pollutant 1 of 1

| |
|--|
| 1. Pollutant Emitted: PM₁₀ , TSP |
| 2. Total Percent Efficiency of Control: 80 % |
| 3. Potential Emissions: PM₁₀_{hourly} = 0.53lb/hr PM₁₀_{yearly} = 0.81 ton/yr TSP_{hourly} = 1.11 lb/hr TSP_{yearly} = 1.70 ton/yr |
| 4. Synthetically Limited? <input checked="" type="checkbox"/> Yes <input type="checkbox"/> No |
| 5. Range of Estimated Fugitive/Other Emissions: <input type="checkbox"/> 1 <input type="checkbox"/> 2 <input type="checkbox"/> 3 <u> 0 </u> to <u> 0 </u> tons/year |
| 6. Emission Factor: 0.0021 lbs/ton Reference: AP-42 (Table 11.19.2-2 controlled) and footnote © for TSP Emissions |
| 7. Emissions Method Code: <input type="checkbox"/> 0 <input type="checkbox"/> 1 <input type="checkbox"/> 2 <input checked="" type="checkbox"/> 3 <input type="checkbox"/> 4 <input type="checkbox"/> 5 |
| 8. Calculation of Emissions (limit to 600 characters): PM₁₀_{yearly} = [(250 ton/hr)(3120 hr/yr)(0.0021 lb/ton)] / (2000 lb/ton) = 0.81 ton/yr PM₁₀_{hour} = [(250 ton/hr)(0.0021 lb/ton)] = 0.53 lb/hr TSP_{yearly} = [(250 ton/hr)(3120 hr/yr)(0.0021 lb/ton)] (2.1) / (2000 lb/ton) = 1.70 ton/yr TSP_{hour} = [(200 ton/hr)(0.0021 lb/ton)] (2.1) = 1.11 lb/hr |
| 9. Pollutant Potential/Estimated Emissions Comment (limit to 200 characters): |

Allowable Emissions (Pollutant identified on front of page)

A.

| | | |
|---|---------|-----------|
| 1. Basis for Allowable Emissions Code: This facility will be subject to 40 CFR Part 60, Subpart 000 rules and regulations. | | |
| 2. Future Effective Date of Allowable Emissions: Initial Visible Emissions Compliance Test | | |
| 3. Requested Allowable Emissions and Units: < 5% Opacity | | |
| 4. Equivalent Allowable Emissions: | lb/hour | tons/year |
| 5. Method of Compliance (limit to 60 characters): Annual EPA Method 9 Compliance Testing. | | |
| 6. Pollutant Allowable Emissions Comment (Desc. of Related Operating Method/Mode) (limit to 200 characters): | | |

B.

| | | |
|---|-------|-----------|
| 1. Basis for Allowable Emissions Code: | | |
| 2. Future Effective Date of Allowable Emissions: | | |
| 3. Requested Allowable Emissions and Units: | | |
| 4. Equivalent Allowable Emissions: | lb/hr | tons/year |
| 5. Method of Compliance (limit to 60 characters): | | |
| 6. Pollutant Allowable Emissions Comment (Desc. of Related Operating Method/Mode) (limit to 200 characters): | | |

**I. VISIBLE EMISSIONS INFORMATION
(Regulated Emissions Units Only)**

Visible Emissions Limitation: Visible Emissions Limitation 1 of 1

| |
|--|
| 1. Visible Emissions Subtype: VE |
| 2. Basis for Allowable Opacity: <input checked="" type="checkbox"/> Rule <input type="checkbox"/> Other |
| 3. Requested Allowable Opacity: Normal Conditions: < 5 % Exceptional Conditions: < 5 % Maximum Period of Excess Opacity Allowed: 0 min/hour |
| 4. Method of Compliance: Annual EPA Method 9 visible emission testing. |
| 5. Visible Emissions Comment (limit to 200 characters): |

Visible Emissions Limitation: Visible Emissions Limitation _____ of _____

| |
|--|
| 1. Visible Emissions Subtype: |
| 2. Basis for Allowable Opacity: <input type="checkbox"/> Rule <input type="checkbox"/> Other |
| 3. Requested Allowable Opacity: Normal Conditions: _____ % Exceptional Conditions: _____ % Maximum Period of Excess Opacity Allowed: _____ min/hour |
| 4. Method of Compliance: |
| 5. Visible Emissions Comment (limit to 200 characters): |

**J. CONTINUOUS MONITOR INFORMATION
(Regulated Emissions Units Only)**

Continuous Monitoring System: Continuous Monitor _____ of _____

| | |
|---|--|
| 1. Parameter Code: NOT APPLICABLE | 2. Pollutant(s): |
| 3. CMS Requirement: | <input type="checkbox"/> Rule <input type="checkbox"/> Other |
| 4. Monitor Information: Manufacturer: Model Number: Serial Number: | |
| 5. Installation Date: | |
| 6. Performance Specification Test Date: | |
| 7. Continuous Monitor Comment (limit to 200 characters): NOT APPLICABLE | |

Continuous Monitoring System: Continuous Monitor _____ of _____

| | |
|--|--|
| 1. Parameter Code: | 2. Pollutant(s): |
| 3. CMS Requirement: | <input type="checkbox"/> Rule <input type="checkbox"/> Other |
| 4. Monitor Information: Manufacturer: Model Number: Serial Number: | |
| 5. Installation Date: | |
| 6. Performance Specification Test Date: | |
| 7. Continuous Monitor Comment (limit to 200 characters): | |

**K. PREVENTION OF SIGNIFICANT DETERIORATION (PSD) INCREMENT
TRACKING INFORMATION
(Regulated and Unregulated Emissions Units)**

PSD Increment Consumption Determination

1. Increment Consuming for Particulate Matter or Sulfur Dioxide?

If the emissions unit addressed in this section emits particulate matter or sulfur dioxide, answer the following series of questions to make a preliminary determination as to whether or not the emissions unit consumes PSD increment for particulate matter or sulfur dioxide. Check the first statement, if any, that applies and skip remaining statements.

-] The emissions unit is undergoing PSD review as part of this application, or has undergone PSD review previously, for particulate matter or sulfur dioxide. If so, emissions unit consumes increment.
-] The facility addressed in this application is classified as an EPA major source pursuant to paragraph (c) of the definition of "major source of air pollution" in Chapter 62-213, F.A.C., and the emissions unit addressed in this section commenced (or will commence) construction after January 6, 1975. If so, baseline emissions are zero, and emissions unit consumes increment.
-] The facility addressed in this application is classified as an EPA major source, and the emissions unit began initial operation after January 6, 1975, but before December 27, 1977. If so, baseline emissions are zero, and emissions unit consumes increment.
-] For any facility, the emissions unit began (or will begin) initial operation after December 27, 1977. If so, baseline emissions are zero, and emissions unit consumes increment.
-] None of the above apply. If so, the baseline emissions of the emissions unit are nonzero. In such case, additional analysis, beyond the scope of this application, is needed to determine whether changes in emissions have occurred (or will occur) after the baseline date that may consume or expand increment.

Emissions Unit Information Section 6 of 9

2. Increment Consuming for Nitrogen Dioxide?

If the emissions unit addressed in this section emits nitrogen oxides, answer the following series of questions to make a preliminary determination as to whether or not the emissions unit consumes PSD increment for nitrogen dioxide. Check first statement, if any, that applies and skip remaining statements.

-] The emissions unit addressed in this section is undergoing PSD review as part of this application, or has undergone PSD review previously, for nitrogen dioxide. If so, emissions unit consumes increment.
-] The facility addressed in this application is classified as an EPA major source pursuant to paragraph (c) of the definition of "major source of air pollution" in Chapter 62-213, F.A.C., and the emissions unit addressed in this section commenced (or will commence) construction after February 8, 1988. If so, baseline emissions are zero, and emissions unit consumes increment.
-] The facility addressed in this application is classified as an EPA major source, and the emissions unit began initial operation after February 8, 1988, but before March 28, 1988. If so, baseline emissions are zero, and emissions unit consumes increment.
-] For any facility, the emissions unit began (or will begin) initial operation after March 28, 1988. If so, baseline emissions are zero, and emissions unit consumes increment.
-] None of the above apply. If so, the baseline emissions of the emissions unit are nonzero. In such case, additional analysis, beyond the scope of this application, is needed to determine whether changes in emissions have occurred (or will occur) after the baseline date that may consume or expand increment.

| | | | |
|---|------------------------------|------------------------------|---|
| 3. Increment Consuming/Expanding Code: | | | |
| PM | <input type="checkbox"/>] C | <input type="checkbox"/>] E | <input checked="" type="checkbox"/>] Unknown |
| SO2 | <input type="checkbox"/>] C | <input type="checkbox"/>] E | <input checked="" type="checkbox"/>] Unknown |
| NO2 | <input type="checkbox"/>] C | <input type="checkbox"/>] E | <input checked="" type="checkbox"/>] Unknown |
| 4. Baseline Emissions: | | | |
| PM ₁₀ / TSP | 0.53 / 1.11 lb/hour | 0.81 / 1.70 tons/year | |
| SO2 | lb/hour | tons/year | |
| NO2 | | tons/year | |
| 5. PSD Comment (limit to 200 characters): | | | |
| | | | |

**L. EMISSIONS UNIT SUPPLEMENTAL INFORMATION
(Regulated Emissions Units Only)**

Supplemental Requirements for All Applications

| |
|---|
| 1. Process Flow Diagram <input checked="" type="checkbox"/> Attached, Document ID: <u> III </u> [] Not Applicable [] Waiver Requested |
| 2. Fuel Analysis or Specification [] Attached, Document ID: _____ [] Not Applicable [] Waiver Requested |
| 3. Detailed Description of Control Equipment <input checked="" type="checkbox"/> Attached, Document ID: <u> V </u> [] Not Applicable [] Waiver Requested |
| 4. Description of Stack Sampling Facilities [] Attached, Document ID: _____ <input checked="" type="checkbox"/> Not Applicable [] Waiver Requested |
| 5. Compliance Test Report [] Attached, Document ID: _____ [] Previously submitted, Date: _____ <input checked="" type="checkbox"/> Not Applicable |
| 6. Procedures for Startup and Shutdown [] Attached, Document ID: _____ <input checked="" type="checkbox"/> Not Applicable |
| 7. Operation and Maintenance Plan <input checked="" type="checkbox"/> Attached, Document ID: <u> VI </u> [] Not Applicable |
| 8. Supplemental Information for Construction Permit Application <input checked="" type="checkbox"/> Attached, Document ID: <u> VII </u> <input checked="" type="checkbox"/> Not Applicable |
| 9. Other Information Required by Rule or Statute [] Attached, Document ID: _____ <input checked="" type="checkbox"/> Not Applicable |

Additional Supplemental Requirements for Category I Applications Only

| |
|--|
| 10. Alternative Methods of Operation <input type="checkbox"/> Attached, Document ID: _____ <input checked="" type="checkbox"/> Not Applicable |
| 11. Alternative Modes of Operation (Emissions Trading) <input type="checkbox"/> Attached, Document ID: _____ <input checked="" type="checkbox"/> Not Applicable |
| 12. Identification of Additional Applicable Requirements <input type="checkbox"/> Attached, Document ID: _____ <input checked="" type="checkbox"/> Not Applicable |
| 13. Compliance Assurance Monitoring Plan <input type="checkbox"/> Attached, Document ID: _____ <input checked="" type="checkbox"/> Not Applicable |
| 14. Acid Rain Application (Hard-copy Required) <input type="checkbox"/> Acid Rain Part - Phase II (Form No. 62-210.900(1)(a)) Attached, Document ID: _____ <input type="checkbox"/> Repowering Extension Plan (Form No. 62-210.900(1)(a)1.) Attached, Document ID: _____ <input type="checkbox"/> New Unit Exemption (Form No. 62-210.900(1)(a)2.) Attached, Document ID: _____ <input type="checkbox"/> Retired Unit Exemption (Form No. 62-210.900(1)(a)3.) Attached, Document ID: _____ <input checked="" type="checkbox"/> Not Applicable |

EMISSIONS ID. NO. 007

**RADIAL STACKER No.1 to
RADIAL STACKER No.2**
(DROP POINT)

III. EMISSIONS UNIT INFORMATION

A separate Emissions Unit Information Section (including subsections A through L as required) must be completed for each emissions unit addressed in this Application for Air Permit. If submitting the application form in hard copy, indicate, in the space provided at the top of each page, the number of this Emissions Unit Information Section and the total number of Emissions Unit Information Sections submitted as part of this application. Some of the subsections comprising the Emissions Unit Information Section of the form are intended for regulated emissions units only. Others are intended for both regulated and unregulated emissions units. Each subsection is appropriately marked.

A. TYPE OF EMISSIONS UNIT (Regulated and Unregulated Emissions Units)

Type of Emissions Unit Addressed in This Section

1. Regulated or Unregulated Emissions Unit? Check one:

The emissions unit addressed in this Emissions Unit Information Section is a regulated emissions unit.

The emissions unit addressed in this Emissions Unit Information Section is an unregulated emissions unit.

2. Single Process, Group of Processes, or Fugitive Only? Check one:

This Emissions Unit Information Section addresses, as a single emissions unit, a single process or production unit, or activity, which produces one or more air pollutants and which has at least one definable emission point (stack or vent).

This Emissions Unit Information Section addresses, as a single emissions unit, a group of process or production units and activities which has at least one definable emission point (stack or vent) but may also produce fugitive emissions.

This Emissions Unit Information Section addresses, as a single emissions unit, one or more process or production units and activities which produce fugitive emissions only.

**B. GENERAL EMISSIONS UNIT INFORMATION
(Regulated and Unregulated Emissions Units)**

Emissions Unit Description and Status

| | | |
|--|--------------------------------------|--|
| 1. Description of Emissions Unit Addressed in This Section (limit to 60 characters): Bohringer Machinery Company, Inc. – Drop Point from Radial Stacker Belt No.1 to Radial Stacker Belt No.2. | | |
| 2. Emissions Unit Identification Number: [] No Corresponding ID [X] Unknown | | |
| 3. Emissions Unit Status Code: Construction | 4. Acid Rain Unit? [] Yes [X] No | 5. Emissions Unit Major Group SIC Code: 14 |
| 6. Emissions Unit Comment (limit to 500 characters): | | |

Emissions Unit Control Equipment

A.

| |
|--|
| 13. Description (limit to 200 characters): The fugitive emissions generated from this drop point where crushed material leaves Radial Stacker No.1 and is dropped to radial stacker belt No. 2 are controlled as needed by the water spray bar system mounted in the area of the discharge hopper under the crusher. |
| 2. Control Device or Method Code: <p align="center">061, 099</p> |

B.

| |
|---|
| 1. Description (limit to 200 characters): |
| |
| 2. Control Device or Method Code: |
| |

C.

| |
|---|
| 1. Description (limit to 200 characters): |
| |
| 2. Control Device or Method Code: |
| |

**C. EMISSIONS UNIT DETAIL INFORMATION
(Regulated Emissions Units Only)**

Emissions Unit Details

| |
|---|
| 1. Initial Startup Date: ASAP |
| 2. Long-term Reserve Shutdown Date: NOT APPLICABLE |
| 3. Package Unit: Radial Stacker Belt No.1 (drop point) to Radial Stacker Belt No. 2 Manufacturer: Self-Fabricated Model No: Unknown |
| 4. Generator Nameplate Rating: MW |
| 5. Incinerator Information: Dwell Temperature: °F Dwell Time: seconds Incinerator Afterburner Temperature: °F |

Emissions Unit Operating Capacity

| |
|--|
| 1. Maximum Heat Input Rate: NONE mmBtu/hr |
| 2. Maximum Incineration Rate: NA lb/hr tons/day |
| 3. Maximum Process or Throughput Rate: 250 ton/hr as raw (crushed) reclaimed asphalt or concrete |
| 4. Maximum Production Rate: 250 ton/hr as reclaimed crushed concrete or asphalt material. (dependent on screen size at the time) |
| 5. Operating Capacity Comment (limit to 200 characters): <p>This material is still moist from previous spray systems and is also dampened before it leaves the belt and drops to it's stockpile. In addition, there may be periods when Radial Stacker Belt is not used, dependent on sites.</p> |

Emissions Unit Operating Schedule

| | | |
|---------------------------------------|----------------------|------------------------|
| Requested Maximum Operating Schedule: | | |
| | 10 hours/day | 6 days/week |
| | 52 weeks/year | 3120 hours/year |

**D. EMISSIONS UNIT REGULATIONS
(Regulated Emissions Units Only)**

Rule Applicability Analysis (Required for Category II applications and Category III applications involving non Title-V sources. See Instructions.)

This facility will be subject to 40 CFR, Part 60, subpart 000 rules and regulations.

List of Applicable Regulations (Required for Category I applications and Category III applications involving Title-V sources. See Instructions.)

| | |
|-----------------------------------|--|
| 62-212.200(56) FAC | |
| 62-296.800 FAC | |
| 40 CFR 60, Subpart 000 | |
| 62-296.310 (2) FAC | |
| 62-297 FAC | |
| 62-297.340 FAC | |
| 62-297.350 FAC | |
| 62-210.350 FAC | |
| Chapter 84-446, Section 3 (12) FS | |
| 62-296.320 FAC | |
| 62-296.310 (3) FAC | |
| 40 CFR 60.11 (d) | |
| 62-4 FAC | |
| 62-210 | |
| | |
| | |
| | |
| | |
| | |
| | |

**E. EMISSION POINT (STACK/VENT) INFORMATION
(Regulated Emissions Units Only)**

Emission Point Description and Type

| | |
|--|------|
| 1. Identification of Point on Plot Plan or Flow Diagram: Drop Point from Radial Stacker No.1 to Radial Stacker Belt No.2 (007) | |
| 2. Emission Point Type Code: <input type="checkbox"/> 1 <input type="checkbox"/> 2 <input type="checkbox"/> 3 <input checked="" type="checkbox"/> 4 | |
| 14. Descriptions of Emissions Points Comprising this Emissions Unit for VE Tracking (limit to 100 characters per point): Visible Emissions will be determined in the area of drop point, where material exits Radial Stacker No.1 and falls to Radial Stacker Belt No.2. | |
| 4. ID Numbers or Descriptions of Emission Units with this Emission Point in Common: NOT APPLICABLE | |
| 5. Discharge Type Code: <input type="checkbox"/> D <input checked="" type="checkbox"/> F <input type="checkbox"/> H <input type="checkbox"/> P <input type="checkbox"/> R <input type="checkbox"/> V <input type="checkbox"/> W | |
| 6. Stack Height: NOT APPLICABLE | feet |
| 7. Exit Diameter: | feet |
| 8. Exit Temperature: | °F |
| 9. Actual Volumetric Flow Rate: | acfm |

Emissions Unit Information Section 7 of 9

| | |
|---|-------|
| 10. Percent Water Vapor : | % |
| 11. Maximum Dry Standard Flow Rate: | dscfm |
| 12. Nonstack Emission Point Height: ~ 8.0 feet | |
| 13. Emission Point UTM Coordinates: <i>(for base/main location of crushing unit only, others not determined as of yet.)</i> Zone: 17 East (km): 499.7 North (km): 3225.5 | |
| 14. Emission Point Comment (limit to 200 characters): Emissions Point will be fugitive only, if any emissions are generated at all. | |

**F. SEGMENT (PROCESS/FUEL) INFORMATION
(Regulated and Unregulated Emissions Units)**

Segment Description and Rate: Segment 1 of 1

| | |
|---|--|
| <p>1. Segment Description (Process/Fuel Type and Associated Operating Method/Mode) (limit to 500 characters):</p> <p>Bohringer Machinery Company, Inc. – Portable Crushing Unit – Radial Stacker Belt No.1 drop point to Radial Stacker Belt No.2. (Material Handling - Emissions related to conveying of reclaimed crushed material).</p> | |
| <p>2. Source Classification Code (SCC): 30502503</p> | |
| <p>3. SCC Units: tons product processed</p> | |
| <p>4. Maximum Hourly Rate: 250 ton/hr</p> | <p>5. Maximum Annual Rate: 780,000 ton/yr</p> |
| <p>6. Estimated Annual Activity Factor: NA</p> | |
| <p>7. Maximum Percent Sulfur: NA</p> | <p>8. Maximum Percent Ash:</p> |
| <p>9. Million Btu per SCC Unit: NA</p> | |
| <p>10. Segment Comment (limit to 200 characters):</p> | |

Segment Description and Rate: Segment of

| | |
|---|-------------------------|
| 1. Segment Description (Process/Fuel Type and Associated Operating Method/Mode) (limit to 500 characters): | |
| 2. Source Classification Code (SCC): | |
| 3. SCC Units: | |
| 4. Maximum Hourly Rate: | 5. Maximum Annual Rate: |
| 6. Estimated Annual Activity Factor: | |
| 7. Maximum Percent Sulfur: | 8. Maximum Percent Ash: |
| 9. Million Btu per SCC Unit: | |
| 10. Segment Comment (limit to 200 characters): | |

H. EMISSIONS UNIT POLLUTANT DETAIL INFORMATION
(Regulated Emissions Units Only - Emissions Limited Pollutants Only)

Pollutant Detail Information: Pollutant 1 of 1

| |
|--|
| 1. Pollutant Emitted: PM₁₀ , TSP |
| 2. Total Percent Efficiency of Control: 80 % |
| 3. Potential Emissions: PM₁₀_{hourly} = 1.20 lb/hr PM₁₀_{yearly} = 1.87 ton/yr TSP_{hourly} = 2.52 lb/hr TSP_{yearly} = 3.93 ton/yr |
| 4. Synthetically Limited? <input checked="" type="checkbox"/> Yes <input type="checkbox"/> No |
| 5. Range of Estimated Fugitive/Other Emissions: <input type="checkbox"/> 1 <input type="checkbox"/> 2 <input type="checkbox"/> 3 <u> 0 </u> to <u> 0 </u> tons/year |
| 6. Emission Factor: 0.0048 lbs/ton Reference: AP-42 (Table 11.19.2-2 controlled) and footnote © for TSP Emissions |
| 7. Emissions Method Code: <input type="checkbox"/> 0 <input type="checkbox"/> 1 <input type="checkbox"/> 2 <input checked="" type="checkbox"/> 3 <input type="checkbox"/> 4 <input type="checkbox"/> 5 |
| 8. Calculation of Emissions (limit to 600 characters): PM₁₀_{yearly} = [(250 ton/hr)(3120 hr/yr)(0.0048 lb/ton)] / (2000 lb/ton) = 1.87 ton/yr PM₁₀_{hour} = [(250 ton/hr)(0.0048 lb/ton)] = 1.20 lb/hr TSP_{yearly} = [(250 ton/hr)(3120 hr/yr)(0.0048 lb/ton)] (2.1) / (2000 lb/ton) = 3.93 ton/yr TSP_{hour} = [(250 ton/hr)(0.0048 lb/ton)] (2.1) = 2.52 lb/hr |
| 9. Pollutant Potential/Estimated Emissions Comment (limit to 200 characters): |

Allowable Emissions (Pollutant identified on front of page)

A.

| | | |
|---|---------|-----------|
| 1. Basis for Allowable Emissions Code: This facility will be subject to 40 CFR Part 60, Subpart 000 rules and regulations. | | |
| 2. Future Effective Date of Allowable Emissions: Initial Visible Emissions Compliance Test | | |
| 3. Requested Allowable Emissions and Units: < 5% Opacity | | |
| 4. Equivalent Allowable Emissions: | lb/hour | tons/year |
| 5. Method of Compliance (limit to 60 characters): Annual EPA Method 9 Compliance Testing. | | |
| 6. Pollutant Allowable Emissions Comment (Desc. of Related Operating Method/Mode) (limit to 200 characters): | | |

B.

| | | |
|---|-------|-----------|
| 1. Basis for Allowable Emissions Code: | | |
| 2. Future Effective Date of Allowable Emissions: | | |
| 3. Requested Allowable Emissions and Units: | | |
| 4. Equivalent Allowable Emissions: | lb/hr | tons/year |
| 5. Method of Compliance (limit to 60 characters): | | |
| 6. Pollutant Allowable Emissions Comment (Desc. of Related Operating Method/Mode) (limit to 200 characters): | | |

**I. VISIBLE EMISSIONS INFORMATION
(Regulated Emissions Units Only)**

Visible Emissions Limitation: Visible Emissions Limitation 1 of 1

| |
|--|
| 1. Visible Emissions Subtype: VE |
| 2. Basis for Allowable Opacity: <input checked="" type="checkbox"/> Rule <input type="checkbox"/> Other |
| 3. Requested Allowable Opacity: Normal Conditions: < 5 % Exceptional Conditions: < 5 % Maximum Period of Excess Opacity Allowed: 0 min/hour |
| 4. Method of Compliance: Annual EPA Method 9 visible emission testing. |
| 5. Visible Emissions Comment (limit to 200 characters): |

Visible Emissions Limitation: Visible Emissions Limitation _____ of _____

| |
|--|
| 1. Visible Emissions Subtype: |
| 2. Basis for Allowable Opacity: <input type="checkbox"/> Rule <input type="checkbox"/> Other |
| 3. Requested Allowable Opacity: Normal Conditions: _____ % Exceptional Conditions: _____ % Maximum Period of Excess Opacity Allowed: _____ min/hour |
| 4. Method of Compliance: |
| 5. Visible Emissions Comment (limit to 200 characters): |

**J. CONTINUOUS MONITOR INFORMATION
(Regulated Emissions Units Only)**

Continuous Monitoring System: Continuous Monitor _____ of _____

| | |
|---|--|
| 1. Parameter Code: NOT APPLICABLE | 2. Pollutant(s): |
| 3. CMS Requirement: | <input type="checkbox"/> Rule <input type="checkbox"/> Other |
| 4. Monitor Information: Manufacturer: Model Number: Serial Number: | |
| 5. Installation Date: | |
| 6. Performance Specification Test Date: | |
| 7. Continuous Monitor Comment (limit to 200 characters): NOT APPLICABLE | |

Continuous Monitoring System: Continuous Monitor _____ of _____

| | |
|--|--|
| 1. Parameter Code: | 2. Pollutant(s): |
| 3. CMS Requirement: | <input type="checkbox"/> Rule <input type="checkbox"/> Other |
| 4. Monitor Information: Manufacturer: Model Number: Serial Number: | |
| 5. Installation Date: | |
| 6. Performance Specification Test Date: | |
| 7. Continuous Monitor Comment (limit to 200 characters): | |

**K. PREVENTION OF SIGNIFICANT DETERIORATION (PSD) INCREMENT
TRACKING INFORMATION
(Regulated and Unregulated Emissions Units)**

PSD Increment Consumption Determination

1. Increment Consuming for Particulate Matter or Sulfur Dioxide?

If the emissions unit addressed in this section emits particulate matter or sulfur dioxide, answer the following series of questions to make a preliminary determination as to whether or not the emissions unit consumes PSD increment for particulate matter or sulfur dioxide. Check the first statement, if any, that applies and skip remaining statements.

-] The emissions unit is undergoing PSD review as part of this application, or has undergone PSD review previously, for particulate matter or sulfur dioxide. If so, emissions unit consumes increment.
-] The facility addressed in this application is classified as an EPA major source pursuant to paragraph (c) of the definition of "major source of air pollution" in Chapter 62-213, F.A.C., and the emissions unit addressed in this section commenced (or will commence) construction after January 6, 1975. If so, baseline emissions are zero, and emissions unit consumes increment.
-] The facility addressed in this application is classified as an EPA major source, and the emissions unit began initial operation after January 6, 1975, but before December 27, 1977. If so, baseline emissions are zero, and emissions unit consumes increment.
-] For any facility, the emissions unit began (or will begin) initial operation after December 27, 1977. If so, baseline emissions are zero, and emissions unit consumes increment.
-] None of the above apply. If so, the baseline emissions of the emissions unit are nonzero. In such case, additional analysis, beyond the scope of this application, is needed to determine whether changes in emissions have occurred (or will occur) after the baseline date that may consume or expand increment.

Emissions Unit Information Section 7 of 9

2. Increment Consuming for Nitrogen Dioxide?

If the emissions unit addressed in this section emits nitrogen oxides, answer the following series of questions to make a preliminary determination as to whether or not the emissions unit consumes PSD increment for nitrogen dioxide. Check first statement, if any, that applies and skip remaining statements.

-] The emissions unit addressed in this section is undergoing PSD review as part of this application, or has undergone PSD review previously, for nitrogen dioxide. If so, emissions unit consumes increment.
-] The facility addressed in this application is classified as an EPA major source pursuant to paragraph (c) of the definition of "major source of air pollution" in Chapter 62-213, F.A.C., and the emissions unit addressed in this section commenced (or will commence) construction after February 8, 1988. If so, baseline emissions are zero, and emissions unit consumes increment.
-] The facility addressed in this application is classified as an EPA major source, and the emissions unit began initial operation after February 8, 1988, but before March 28, 1988. If so, baseline emissions are zero, and emissions unit consumes increment.
-] For any facility, the emissions unit began (or will begin) initial operation after March 28, 1988. If so, baseline emissions are zero, and emissions unit consumes increment.
-] None of the above apply. If so, the baseline emissions of the emissions unit are nonzero. In such case, additional analysis, beyond the scope of this application, is needed to determine whether changes in emissions have occurred (or will occur) after the baseline date that may consume or expand increment.

| | | |
|---|----------------------------|--|
| 3. Increment Consuming/Expanding Code: | | |
| PM | <input type="checkbox"/> C | <input type="checkbox"/> E <input checked="" type="checkbox"/> Unknown |
| SO2 | <input type="checkbox"/> C | <input type="checkbox"/> E <input checked="" type="checkbox"/> Unknown |
| NO2 | <input type="checkbox"/> C | <input type="checkbox"/> E <input checked="" type="checkbox"/> Unknown |
| 4. Baseline Emissions: | | |
| PM ₁₀ / TSP | 1.20/2.52 lb/hour | 1.87 / 3.93 tons/year |
| SO2 | lb/hour | tons/year |
| NO2 | | tons/year |
| 5. PSD Comment (limit to 200 characters): | | |
| | | |

**L. EMISSIONS UNIT SUPPLEMENTAL INFORMATION
(Regulated Emissions Units Only)**

Supplemental Requirements for All Applications

| |
|--|
| 1. Process Flow Diagram <input checked="" type="checkbox"/> Attached, Document ID: <u>III</u> <input type="checkbox"/> Not Applicable <input type="checkbox"/> Waiver Requested |
| 2. Fuel Analysis or Specification <input type="checkbox"/> Attached, Document ID: _____ <input type="checkbox"/> Not Applicable <input type="checkbox"/> Waiver Requested |
| 3. Detailed Description of Control Equipment <input checked="" type="checkbox"/> Attached, Document ID: <u>V</u> <input type="checkbox"/> Not Applicable <input type="checkbox"/> Waiver Requested |
| 4. Description of Stack Sampling Facilities <input type="checkbox"/> Attached, Document ID: _____ <input checked="" type="checkbox"/> Not Applicable <input type="checkbox"/> Waiver Requested |
| 5. Compliance Test Report <input type="checkbox"/> Attached, Document ID: _____ <input type="checkbox"/> Previously submitted, Date: _____ <input checked="" type="checkbox"/> Not Applicable |
| 6. Procedures for Startup and Shutdown <input type="checkbox"/> Attached, Document ID: _____ <input checked="" type="checkbox"/> Not Applicable |
| 7. Operation and Maintenance Plan <input checked="" type="checkbox"/> Attached, Document ID: <u>VI</u> <input type="checkbox"/> Not Applicable |
| 8. Supplemental Information for Construction Permit Application <input checked="" type="checkbox"/> Attached, Document ID: <u>VII</u> <input checked="" type="checkbox"/> Not Applicable |
| 9. Other Information Required by Rule or Statute <input type="checkbox"/> Attached, Document ID: _____ <input checked="" type="checkbox"/> Not Applicable |

Additional Supplemental Requirements for Category I Applications Only

| |
|--|
| 10. Alternative Methods of Operation <input type="checkbox"/> Attached, Document ID: _____ <input checked="" type="checkbox"/> Not Applicable |
| 11. Alternative Modes of Operation (Emissions Trading) <input type="checkbox"/> Attached, Document ID: _____ <input checked="" type="checkbox"/> Not Applicable |
| 12. Identification of Additional Applicable Requirements <input type="checkbox"/> Attached, Document ID: _____ <input checked="" type="checkbox"/> Not Applicable |
| 13. Compliance Assurance Monitoring Plan <input type="checkbox"/> Attached, Document ID: _____ <input checked="" type="checkbox"/> Not Applicable |
| 14. Acid Rain Application (Hard-copy Required) <input type="checkbox"/> Acid Rain Part - Phase II (Form No. 62-210.900(1)(a)) Attached, Document ID: _____ <input type="checkbox"/> Repowering Extension Plan (Form No. 62-210.900(1)(a)1.) Attached, Document ID: _____ <input type="checkbox"/> New Unit Exemption (Form No. 62-210.900(1)(a)2.) Attached, Document ID: _____ <input type="checkbox"/> Retired Unit Exemption (Form No. 62-210.900(1)(a)3.) Attached, Document ID: _____ <input checked="" type="checkbox"/> Not Applicable |

EMISSIONS ID. NO. 008

**RADIAL STACKER No.1 or No.2
To STOCKPILE
(DROP POINT)**

III. EMISSIONS UNIT INFORMATION

A separate Emissions Unit Information Section (including subsections A through L as required) must be completed for each emissions unit addressed in this Application for Air Permit. If submitting the application form in hard copy, indicate, in the space provided at the top of each page, the number of this Emissions Unit Information Section and the total number of Emissions Unit Information Sections submitted as part of this application. Some of the subsections comprising the Emissions Unit Information Section of the form are intended for regulated emissions units only. Others are intended for both regulated and unregulated emissions units. Each subsection is appropriately marked.

A. TYPE OF EMISSIONS UNIT (Regulated and Unregulated Emissions Units)

Type of Emissions Unit Addressed in This Section

1. Regulated or Unregulated Emissions Unit? Check one:

The emissions unit addressed in this Emissions Unit Information Section is a regulated emissions unit.

The emissions unit addressed in this Emissions Unit Information Section is an unregulated emissions unit.

2. Single Process, Group of Processes, or Fugitive Only? Check one:

This Emissions Unit Information Section addresses, as a single emissions unit, a single process or production unit, or activity, which produces one or more air pollutants and which has at least one definable emission point (stack or vent).

This Emissions Unit Information Section addresses, as a single emissions unit, a group of process or production units and activities which has at least one definable emission point (stack or vent) but may also produce fugitive emissions.

This Emissions Unit Information Section addresses, as a single emissions unit, one or more process or production units and activities which produce fugitive emissions only.

**B. GENERAL EMISSIONS UNIT INFORMATION
(Regulated and Unregulated Emissions Units)**

Emissions Unit Description and Status

| | | |
|---|--------------------------------------|--|
| 1. Description of Emissions Unit Addressed in This Section (limit to 60 characters): Bohringer Machinery Company, Inc. – Drop Point from Radial Stacker Belt No.1 or No.2 to stockpile. | | |
| 2. Emissions Unit Identification Number: [] No Corresponding ID [X] Unknown | | |
| 3. Emissions Unit Status Code: Construction | 4. Acid Rain Unit? [] Yes [X] No | 5. Emissions Unit Major Group SIC Code: 14 |
| 6. Emissions Unit Comment (limit to 500 characters): | | |

Emissions Unit Control Equipment

A.

| |
|--|
| 15. Description (limit to 200 characters): This material is still moist from previous spray systems. In addition, the stacker belts are kept close to the top of the stockpiles as to control airborne fugitive emissions. |
| 2. Control Device or Method Code: 061, 099 |

B.

1. Description (limit to 200 characters):

2. Control Device or Method Code:

C.

1. Description (limit to 200 characters):

2. Control Device or Method Code:

**C. EMISSIONS UNIT DETAIL INFORMATION
(Regulated Emissions Units Only)**

Emissions Unit Details

| |
|--|
| 1. Initial Startup Date: ASAP |
| 2. Long-term Reserve Shutdown Date: NOT APPLICABLE |
| 3. Package Unit: Radial Stacker Belt No. 1 or No.2 drop point to stockpile Manufacturer: Self - fabricated. Model No: Unknown |
| 4. Generator Nameplate Rating: MW |
| 5. Incinerator Information: <div style="display: flex; justify-content: space-between; margin-left: 150px;"> Dwell Temperature: °F </div> <div style="display: flex; justify-content: space-between; margin-left: 150px;"> Dwell Time: seconds </div> <div style="display: flex; justify-content: space-between; margin-left: 150px;"> Incinerator Afterburner Temperature: °F </div> |

Emissions Unit Operating Capacity

| |
|--|
| 1. Maximum Heat Input Rate: NONE mmBtu/hr |
| 2. Maximum Incineration Rate: NA lb/hr tons/day |
| 3. Maximum Process or Throughput Rate: 250 ton/hr as raw (crushed) reclaimed asphalt or concrete |
| 4. Maximum Production Rate: 250 ton/hr as reclaimed crushed concrete or asphalt material. (dependent on screen size at the time) |
| 5. Operating Capacity Comment (limit to 200 characters): <p>This material is still moist from previous spray systems. Radial Belt No.2 may not be used at all sites.</p> |

Emissions Unit Operating Schedule

| | | |
|---------------------------------------|-----------------|--|
| Requested Maximum Operating Schedule: | | |
| 10 hours/day | 6 days/week | |
| 52 weeks/year | 3120 hours/year | |

**D. EMISSIONS UNIT REGULATIONS
(Regulated Emissions Units Only)**

Rule Applicability Analysis (Required for Category II applications and Category III applications involving non Title-V sources. See Instructions.)

This facility will be subject to 40 CFR, Part 60, subpart 000 rules and regulations.

List of Applicable Regulations (Required for Category I applications and Category III applications involving Title-V sources. See Instructions.)

| | |
|-----------------------------------|--|
| 62-212.200(56) FAC | |
| 62-296.800 FAC | |
| 40 CFR 60, Subpart 000 | |
| 62-296.310 (2) FAC | |
| 62-297 FAC | |
| 62-297.340 FAC | |
| 62-297.350 FAC | |
| 62-210.350 FAC | |
| Chapter 84-446, Section 3 (12) FS | |
| 62-296.320 FAC | |
| 62-296.310 (3) FAC | |
| 40 CFR 60.11 (d) | |
| 62-4 FAC | |
| 62-210 | |
| | |
| | |
| | |
| | |
| | |
| | |

**E. EMISSION POINT (STACK/VENT) INFORMATION
(Regulated Emissions Units Only)**

Emission Point Description and Type

| | |
|--|------|
| 1. Identification of Point on Plot Plan or Flow Diagram: Drop Point from Radial Stacker Belt No.1 or No.2 to stockpile (008) | |
| 2. Emission Point Type Code: <input type="checkbox"/> 1 <input type="checkbox"/> 2 <input type="checkbox"/> 3 <input checked="" type="checkbox"/> 4 | |
| 16. Descriptions of Emissions Points Comprising this Emissions Unit for VE Tracking (limit to 100 characters per point): Visible Emissions will be determined in the area of drop point, where material exits Radial Stacker Belt No.1 or No.2 and is dropped to it's stockpile. | |
| 4. ID Numbers or Descriptions of Emission Units with this Emission Point in Common: NOT APPLICABLE | |
| 5. Discharge Type Code: <input type="checkbox"/> D <input checked="" type="checkbox"/> F <input type="checkbox"/> H <input type="checkbox"/> P <input type="checkbox"/> R <input type="checkbox"/> V <input type="checkbox"/> W | |
| 6. Stack Height: NOT APPLICABLE | feet |
| 7. Exit Diameter: | feet |
| 8. Exit Temperature: | °F |
| 9. Actual Volumetric Flow Rate: acfm | |

Emissions Unit Information Section 8 of 9

| | |
|---|-------|
| 10. Percent Water Vapor : | % |
| 11. Maximum Dry Standard Flow Rate: | dscfm |
| 12. Nonstack Emission Point Height: ~ 0.0 to 20.0 feet | |
| 13. Emission Point UTM Coordinates: <i>(for base/main location of crushing unit only, others not determined as of yet.)</i> Zone: 17 East (km): 499.7 North (km): 3225.5 | |
| 14. Emission Point Comment (limit to 200 characters): Emissions Point will be fugitive only, if any emissions are generated at all. | |

**F. SEGMENT (PROCESS/FUEL) INFORMATION
(Regulated and Unregulated Emissions Units)**

Segment Description and Rate: Segment 1 of 1

| | |
|---|--|
| <p>1. Segment Description (Process/Fuel Type and Associated Operating Method/Mode) (limit to 500 characters):</p> <p>Bohringer Machinery Company, Inc. – Portable Crushing Unit – Drop point from Radial Stacker Belt No.1 or No.2 to stockpile. (Material Handling - Emissions related to conveying of reclaimed crushed material).</p> | |
| <p>2. Source Classification Code (SCC): 30502503</p> | |
| <p>3. SCC Units: tons product processed</p> | |
| <p>4. Maximum Hourly Rate: 250 ton/hr</p> | <p>5. Maximum Annual Rate: 780,000 ton/yr</p> |
| <p>6. Estimated Annual Activity Factor: NA</p> | |
| <p>7. Maximum Percent Sulfur: NA</p> | <p>8. Maximum Percent Ash:</p> |
| <p>9. Million Btu per SCC Unit: NA</p> | |
| <p>10. Segment Comment (limit to 200 characters):</p> | |

Segment Description and Rate: Segment _____ of _____

| | |
|---|-------------------------|
| 1. Segment Description (Process/Fuel Type and Associated Operating Method/Mode) (limit to 500 characters): | |
| 2. Source Classification Code (SCC): | |
| 3. SCC Units: | |
| 4. Maximum Hourly Rate: | 5. Maximum Annual Rate: |
| 6. Estimated Annual Activity Factor: | |
| 7. Maximum Percent Sulfur: | 8. Maximum Percent Ash: |
| 9. Million Btu per SCC Unit: | |
| 10. Segment Comment (limit to 200 characters): | |

G. EMISSIONS UNIT POLLUTANTS
(Regulated and Unregulated Emissions Units)

| 1. Pollutant Emitted | 2. Primary Control Device Code | 3. Secondary Control Device Code | 4. Pollutant Regulatory Code |
|----------------------|--------------------------------|----------------------------------|------------------------------|
| PM10 | 061 | 099 | WP |
| TSP | 061 | 099 | WP |
| | | | |
| | | | |
| | | | |
| | | | |
| | | | |
| | | | |
| | | | |
| | | | |
| | | | |
| | | | |
| | | | |
| | | | |
| | | | |
| | | | |
| | | | |
| | | | |
| | | | |

H. EMISSIONS UNIT POLLUTANT DETAIL INFORMATION
(Regulated Emissions Units Only - Emissions Limited Pollutants Only)

Pollutant Detail Information: **Pollutant 1 of 1**

| |
|--|
| 1. Pollutant Emitted: PM₁₀ , TSP |
| 2. Total Percent Efficiency of Control: 80 % |
| 3. Potential Emissions: PM₁₀_{hourly} = 1.20 lb/hr PM₁₀_{yearly} = 1.87 ton/yr TSP_{hourly} = 2.52 lb/hr TSP_{yearly} = 3.93 ton/yr |
| 4. Synthetically Limited? <input checked="" type="checkbox"/> Yes <input type="checkbox"/> No |
| 5. Range of Estimated Fugitive/Other Emissions: <input type="checkbox"/> 1 <input type="checkbox"/> 2 <input type="checkbox"/> 3 <u> 0 </u> to <u> 0 </u> tons/year |
| 6. Emission Factor: 0.0048 lbs/ton Reference: AP-42 (Table 11.19.2-2 controlled) and footnote © for TSP Emissions |
| 7. Emissions Method Code: <input type="checkbox"/> 0 <input type="checkbox"/> 1 <input type="checkbox"/> 2 <input checked="" type="checkbox"/> 3 <input type="checkbox"/> 4 <input type="checkbox"/> 5 |
| 8. Calculation of Emissions (limit to 600 characters): PM₁₀_{yearly} = [(250 ton/hr)(3120 hr/yr)(0.0048 lb/ton)] / (2000 lb/ton) = 1.87 ton/yr PM₁₀_{hour} = [(250 ton/hr)(0.0048 lb/ton)] = 1.20 lb/hr TSP_{yearly} = [(250 ton/hr)(3120 hr/yr)(0.0048 lb/ton)] (2.1) / (2000 lb/ton) = 3.83 ton/yr TSP_{hour} = [(250 ton/hr)(0.0048 lb/ton)] (2.1) = 2.52 lb/hr |
| 9. Pollutant Potential/Estimated Emissions Comment (limit to 200 characters): |

Allowable Emissions (Pollutant identified on front of page)

A.

| | | |
|---|---------|-----------|
| 1. Basis for Allowable Emissions Code: This facility will be subject to 40 CFR Part 60, Subpart 000 rules and regulations. | | |
| 2. Future Effective Date of Allowable Emissions: Initial Visible Emissions Compliance Test | | |
| 3. Requested Allowable Emissions and Units: < 10% Opacity | | |
| 4. Equivalent Allowable Emissions: | lb/hour | tons/year |
| 5. Method of Compliance (limit to 60 characters): Annual EPA Method 9 Compliance Testing. | | |
| 6. Pollutant Allowable Emissions Comment (Desc. of Related Operating Method/Mode) (limit to 200 characters): | | |

B.

| | | |
|---|-------|-----------|
| 1. Basis for Allowable Emissions Code: | | |
| 2. Future Effective Date of Allowable Emissions: | | |
| 3. Requested Allowable Emissions and Units: | | |
| 4. Equivalent Allowable Emissions: | lb/hr | tons/year |
| 5. Method of Compliance (limit to 60 characters): | | |
| 6. Pollutant Allowable Emissions Comment (Desc. of Related Operating Method/Mode) (limit to 200 characters): | | |

I. VISIBLE EMISSIONS INFORMATION
(Regulated Emissions Units Only)

Visible Emissions Limitation: Visible Emissions Limitation 1 of 1

| |
|--|
| 1. Visible Emissions Subtype: VE |
| 2. Basis for Allowable Opacity: <input checked="" type="checkbox"/> Rule <input type="checkbox"/> Other |
| 3. Requested Allowable Opacity: Normal Conditions: < 10 % Exceptional Conditions: < 10 % Maximum Period of Excess Opacity Allowed: 0 min/hour |
| 4. Method of Compliance: Annual EPA Method 9 visible emission testing. |
| 5. Visible Emissions Comment (limit to 200 characters): |

Visible Emissions Limitation: Visible Emissions Limitation _____ of _____

| |
|--|
| 1. Visible Emissions Subtype: |
| 2. Basis for Allowable Opacity: <input type="checkbox"/> Rule <input type="checkbox"/> Other |
| 3. Requested Allowable Opacity: Normal Conditions: _____ % Exceptional Conditions: _____ % Maximum Period of Excess Opacity Allowed: _____ min/hour |
| 4. Method of Compliance: |
| 5. Visible Emissions Comment (limit to 200 characters): |

**J. CONTINUOUS MONITOR INFORMATION
(Regulated Emissions Units Only)**

Continuous Monitoring System: Continuous Monitor _____ of _____

| | |
|---|--|
| 1. Parameter Code: NOT APPLICABLE | 2. Pollutant(s): |
| 3. CMS Requirement: | <input type="checkbox"/> Rule <input type="checkbox"/> Other |
| 4. Monitor Information: Manufacturer: Model Number: Serial Number: | |
| 5. Installation Date: | |
| 6. Performance Specification Test Date: | |
| 7. Continuous Monitor Comment (limit to 200 characters): NOT APPLICABLE | |

Continuous Monitoring System: Continuous Monitor _____ of _____

| | |
|--|--|
| 1. Parameter Code: | 2. Pollutant(s): |
| 3. CMS Requirement: | <input type="checkbox"/> Rule <input type="checkbox"/> Other |
| 4. Monitor Information: Manufacturer: Model Number: Serial Number: | |
| 5. Installation Date: | |
| 6. Performance Specification Test Date: | |
| 7. Continuous Monitor Comment (limit to 200 characters): | |

**K. PREVENTION OF SIGNIFICANT DETERIORATION (PSD) INCREMENT
TRACKING INFORMATION
(Regulated and Unregulated Emissions Units)**

PSD Increment Consumption Determination

1. Increment Consuming for Particulate Matter or Sulfur Dioxide?

If the emissions unit addressed in this section emits particulate matter or sulfur dioxide, answer the following series of questions to make a preliminary determination as to whether or not the emissions unit consumes PSD increment for particulate matter or sulfur dioxide. Check the first statement, if any, that applies and skip remaining statements.

-] The emissions unit is undergoing PSD review as part of this application, or has undergone PSD review previously, for particulate matter or sulfur dioxide. If so, emissions unit consumes increment.
-] The facility addressed in this application is classified as an EPA major source pursuant to paragraph (c) of the definition of "major source of air pollution" in Chapter 62-213, F.A.C., and the emissions unit addressed in this section commenced (or will commence) construction after January 6, 1975. If so, baseline emissions are zero, and emissions unit consumes increment.
-] The facility addressed in this application is classified as an EPA major source, and the emissions unit began initial operation after January 6, 1975, but before December 27, 1977. If so, baseline emissions are zero, and emissions unit consumes increment.
-] For any facility, the emissions unit began (or will begin) initial operation after December 27, 1977. If so, baseline emissions are zero, and emissions unit consumes increment.
-] None of the above apply. If so, the baseline emissions of the emissions unit are nonzero. In such case, additional analysis, beyond the scope of this application, is needed to determine whether changes in emissions have occurred (or will occur) after the baseline date that may consume or expand increment.

2. Increment Consuming for Nitrogen Dioxide?

If the emissions unit addressed in this section emits nitrogen oxides, answer the following series of questions to make a preliminary determination as to whether or not the emissions unit consumes PSD increment for nitrogen dioxide. Check first statement, if any, that applies and skip remaining statements.

-] The emissions unit addressed in this section is undergoing PSD review as part of this application, or has undergone PSD review previously, for nitrogen dioxide. If so, emissions unit consumes increment.
-] The facility addressed in this application is classified as an EPA major source pursuant to paragraph (c) of the definition of "major source of air pollution" in Chapter 62-213, F.A.C., and the emissions unit addressed in this section commenced (or will commence) construction after February 8, 1988. If so, baseline emissions are zero, and emissions unit consumes increment.
-] The facility addressed in this application is classified as an EPA major source, and the emissions unit began initial operation after February 8, 1988, but before March 28, 1988. If so, baseline emissions are zero, and emissions unit consumes increment.
-] For any facility, the emissions unit began (or will begin) initial operation after March 28, 1988. If so, baseline emissions are zero, and emissions unit consumes increment.
-] None of the above apply. If so, the baseline emissions of the emissions unit are nonzero. In such case, additional analysis, beyond the scope of this application, is needed to determine whether changes in emissions have occurred (or will occur) after the baseline date that may consume or expand increment.

| | | | |
|---|------------------------------|------------------------------|---|
| 3. Increment Consuming/Expanding Code: | | | |
| PM | <input type="checkbox"/>] C | <input type="checkbox"/>] E | <input checked="" type="checkbox"/>] Unknown |
| SO2 | <input type="checkbox"/>] C | <input type="checkbox"/>] E | <input checked="" type="checkbox"/>] Unknown |
| NO2 | <input type="checkbox"/>] C | <input type="checkbox"/>] E | <input checked="" type="checkbox"/>] Unknown |
| 4. Baseline Emissions: | | | |
| PM ₁₀ / TSP | 1.20 / 2.52 lb/hour | 1.87 / 3.93 tons/year | |
| SO2 | lb/hour | tons/year | |
| NO2 | | tons/year | |
| 5. PSD Comment (limit to 200 characters): | | | |
| | | | |

**L. EMISSIONS UNIT SUPPLEMENTAL INFORMATION
(Regulated Emissions Units Only)**

Supplemental Requirements for All Applications

| |
|---|
| 1. Process Flow Diagram <input checked="" type="checkbox"/> Attached, Document ID: <u> III </u> [] Not Applicable [] Waiver Requested |
| 2. Fuel Analysis or Specification [] Attached, Document ID: _____ [] Not Applicable [] Waiver Requested |
| 3. Detailed Description of Control Equipment <input checked="" type="checkbox"/> Attached, Document ID: <u> V </u> [] Not Applicable [] Waiver Requested |
| 4. Description of Stack Sampling Facilities [] Attached, Document ID: _____ <input checked="" type="checkbox"/> Not Applicable [] Waiver Requested |
| 5. Compliance Test Report [] Attached, Document ID: _____ [] Previously submitted, Date: _____ <input checked="" type="checkbox"/> Not Applicable |
| 6. Procedures for Startup and Shutdown [] Attached, Document ID: _____ <input checked="" type="checkbox"/> Not Applicable |
| 7. Operation and Maintenance Plan <input checked="" type="checkbox"/> Attached, Document ID: <u> VI </u> [] Not Applicable |
| 8. Supplemental Information for Construction Permit Application <input checked="" type="checkbox"/> Attached, Document ID: <u> VII </u> <input checked="" type="checkbox"/> Not Applicable |
| 9. Other Information Required by Rule or Statute [] Attached, Document ID: _____ <input checked="" type="checkbox"/> Not Applicable |

Additional Supplemental Requirements for Category I Applications Only

| |
|--|
| 10. Alternative Methods of Operation <input type="checkbox"/> Attached, Document ID: _____ <input checked="" type="checkbox"/> Not Applicable |
| 11. Alternative Modes of Operation (Emissions Trading) <input type="checkbox"/> Attached, Document ID: _____ <input checked="" type="checkbox"/> Not Applicable |
| 12. Identification of Additional Applicable Requirements <input type="checkbox"/> Attached, Document ID: _____ <input checked="" type="checkbox"/> Not Applicable |
| 13. Compliance Assurance Monitoring Plan <input type="checkbox"/> Attached, Document ID: _____ <input checked="" type="checkbox"/> Not Applicable |
| 14. Acid Rain Application (Hard-copy Required) <input type="checkbox"/> Acid Rain Part - Phase II (Form No. 62-210.900(1)(a)) Attached, Document ID: _____ <input type="checkbox"/> Repowering Extension Plan (Form No. 62-210.900(1)(a)1.) Attached, Document ID: _____ <input type="checkbox"/> New Unit Exemption (Form No. 62-210.900(1)(a)2.) Attached, Document ID: _____ <input type="checkbox"/> Retired Unit Exemption (Form No. 62-210.900(1)(a)3.) Attached, Document ID: _____ <input checked="" type="checkbox"/> Not Applicable |

III. EMISSIONS UNIT INFORMATION

A separate Emissions Unit Information Section (including subsections A through L as required) must be completed for each emissions unit addressed in this Application for Air Permit. If submitting the application form in hard copy, indicate, in the space provided at the top of each page, the number of this Emissions Unit Information Section and the total number of Emissions Unit Information Sections submitted as part of this application. Some of the subsections comprising the Emissions Unit Information Section of the form are intended for regulated emissions units only. Others are intended for both regulated and unregulated emissions units. Each subsection is appropriately marked.

A. TYPE OF EMISSIONS UNIT (Regulated and Unregulated Emissions Units)

Type of Emissions Unit Addressed in This Section

1. Regulated or Unregulated Emissions Unit? Check one:

The emissions unit addressed in this Emissions Unit Information Section is a regulated emissions unit.

The emissions unit addressed in this Emissions Unit Information Section is an unregulated emissions unit.

2. Single Process, Group of Processes, or Fugitive Only? Check one:

This Emissions Unit Information Section addresses, as a single emissions unit, a single process or production unit, or activity, which produces one or more air pollutants and which has at least one definable emission point (stack or vent).

This Emissions Unit Information Section addresses, as a single emissions unit, a group of process or production units and activities which has at least one definable emission point (stack or vent) but may also produce fugitive emissions.

This Emissions Unit Information Section addresses, as a single emissions unit, one or more process or production units and activities which produce fugitive emissions only.

**B. GENERAL EMISSIONS UNIT INFORMATION
(Regulated and Unregulated Emissions Units)**

Emissions Unit Description and Status

| | | |
|--|--------------------------------------|---|
| 1. Description of Emissions Unit Addressed in This Section (limit to 60 characters): Caterpillar, No.2 virgin diesel fired, 400KVA, 320 kW Generator Set – used to supply electrical power to crushing plant. Sulfur limit in fuel oil limited to 0.5% by weight. | | |
| 2. Emissions Unit Identification Number: [] No Corresponding ID [X] Unknown | | |
| 3. Emissions Unit Status Code: <p align="center">A</p> | 4. Acid Rain Unit? [] Yes [X] No | 5. Emissions Unit Major Group SIC Code: <p align="center">14</p> |
| 6. Emissions Unit Comment (limit to 500 characters): Caterpillar Diesel fired Generator Set used to supply electrical power to crushing plant. Generator fired on No.2 virgin diesel fuel oil with a maximum sulfur content of 0.5% by weight, 138,000 BTU/gal and maximum fuel consumption at maximum of 25 gal/hr. | | |

Emissions Unit Control Equipment

A.

| |
|---|
| 17. Description (limit to 200 characters): UNCONTROLLED |
| 2. Control Device or Method Code: |

B.

| |
|---|
| 1. Description (limit to 200 characters): |
| |
| 2. Control Device or Method Code: |
| |

C.

| |
|---|
| 1. Description (limit to 200 characters): |
| |
| 2. Control Device or Method Code: |
| |

**C. EMISSIONS UNIT DETAIL INFORMATION
(Regulated Emissions Units Only)**

Emissions Unit Details

| |
|---|
| 1. Initial Startup Date: ASAP |
| 2. Long-term Reserve Shutdown Date: NOT APPLICABLE |
| 3. Package Unit: Virgin Diesel fired Generator Set Manufacturer: Caterpillar Model No: 400 KVA |
| 4. Generator Nameplate Rating: 320 kW |
| 5. Incinerator Information: <div style="text-align: right; padding-right: 100px;">Dwell Temperature: °F</div> <div style="text-align: right; padding-right: 100px;">Dwell Time: seconds</div> <div style="text-align: right; padding-right: 100px;">Incinerator Afterburner Temperature: °F</div> |

Emissions Unit Operating Capacity

| |
|---|
| 1. Maximum Heat Input Rate: 6.21 mmBtu/hr |
| 2. Maximum Incineration Rate: NA lb/hr tons/day |
| Maximum Process or Throughput Rate: Consumes No.2 fuel oil at 25 gallons per hour maximum. |
| 4. Maximum Production Rate: 25 gallons per hour |
| 5. Operating Capacity Comment (limit to 200 characters): Caterpillar Diesel fired Generator Set used to supply electrical power to crushing plant. Generator fired on No.2 virgin diesel fuel oil with a maximum sulfur content of 0.5% by weight, 138,000 BTU/gal and maximum fuel consumption at 25 gal/hr. |

Emissions Unit Operating Schedule

| | | |
|---------------------------------------|------------------------|--|
| Requested Maximum Operating Schedule: | | |
| 10 hours/day | 6 days/week | |
| 52 weeks/year | 3120 hours/year | |

EMISSIONS ID. NO. 009

**CATERPILLAR INC. -
GENERATOR SET**

F. SEGMENT (PROCESS/FUEL) INFORMATION
(Regulated and Unregulated Emissions Units)

Segment Description and Rate: Segment 1 of 1

| | |
|---|--|
| 1. Segment Description (Process/Fuel Type and Associated Operating Method/Mode) (limit to 500 characters): Eagle Crusher Company, Inc. – Portable Crushing Unit – Emissions from Caterpillar Generator Set fired on No.2 virgin diesel fuel oil with a sulfur limit of 0.5% by weight. | |
| 2. Source Classification Code (SCC): 20200401 | |
| 3. SCC Units: 1000 gallons burned | |
| 4. Maximum Hourly Rate: 25.0 gal/hr @ worst case scenario | 5. Maximum Annual Rate: 78,000 gal/yr @ max. |
| 6. Estimated Annual Activity Factor: 0.50 tpy @ worst case scenario at worst site. | |
| 7. Maximum Percent Sulfur: 0.50 % by weight | 8. Maximum Percent Ash: NEG. |
| 9. Million Btu per SCC Unit: 138.0 MMBtu/SCC Unit | |
| 10. Segment Comment (limit to 200 characters): | |

Segment Description and Rate: Segment of

| | |
|---|-------------------------|
| 1. Segment Description (Process/Fuel Type and Associated Operating Method/Mode) (limit to 500 characters): | |
| 2. Source Classification Code (SCC): | |
| 3. SCC Units: | |
| 4. Maximum Hourly Rate: | 5. Maximum Annual Rate: |
| 6. Estimated Annual Activity Factor: | |
| 7. Maximum Percent Sulfur: | 8. Maximum Percent Ash: |
| 9. Million Btu per SCC Unit: | |
| 10. Segment Comment (limit to 200 characters): | |

**D. EMISSIONS UNIT REGULATIONS
(Regulated Emissions Units Only)**

Rule Applicability Analysis (Required for Category II applications and Category III applications involving non Title-V sources. See Instructions.)

This emissions unit will be subject to 62-296.320 of the FAC

List of Applicable Regulations (Required for Category I applications and Category III applications involving Title-V sources. See Instructions.)

| | |
|-----------------------------------|--|
| 62-212.200(56) FAC | |
| 62-296.800 FAC | |
| 40 CFR 60, Subpart 000 | |
| 62-296.310 (2) FAC | |
| 62-297 FAC | |
| 62-297.340 FAC | |
| 62-297.350 FAC | |
| 62-210.350 FAC | |
| Chapter 84-446, Section 3 (12) FS | |
| 62-296.320 FAC | |
| 62-296.310 (3) FAC | |
| 40 CFR 60.11 (d) | |
| 62-4 FAC | |
| 62-210 | |
| | |
| | |
| | |
| | |
| | |
| | |

**E. EMISSION POINT (STACK/VENT) INFORMATION
(Regulated Emissions Units Only)**

Emission Point Description and Type

| |
|---|
| 1. Identification of Point on Plot Plan or Flow Diagram: Caterpillar Diesel fired Generator-Set (009) |
| 2. Emission Point Type Code: <input checked="" type="checkbox"/> 1 <input type="checkbox"/> 2 <input type="checkbox"/> 3 <input type="checkbox"/> 4 |
| 18. Descriptions of Emissions Points Comprising this Emissions Unit for VE Tracking (limit to 100 characters per point): Visible Emissions will be determined from the 12" round exhaust stack exiting this unit. |
| 4. ID Numbers or Descriptions of Emission Units with this Emission Point in Common: NOT APPLICABLE |
| 5. Discharge Type Code: <input type="checkbox"/> D <input checked="" type="checkbox"/> F <input type="checkbox"/> H <input type="checkbox"/> P <input type="checkbox"/> R <input type="checkbox"/> V <input type="checkbox"/> W |
| 6. Stack Height: ~ 15 feet |
| 7. Exit Diameter: ~ 12" |
| 8. Exit Temperature: ~ 750°F °F |

| |
|---|
| 9. Actual Volumetric Flow Rate: ~ 5300 acfm |
|---|

| | |
|--|--------------------|
| 10. Percent Water Vapor : unknown | % |
| 11. Maximum Dry Standard Flow Rate: | dscfm |
| 12. Nonstack Emission Point Height: | |
| 13. Emission Point UTM Coordinates: <i>(for base/main location of crushing unit only, others not determined as of yet.)</i> | |
| Zone: 17 | East (km): 499.7 |
| | North (km): 3225.5 |
| 14. Emission Point Comment (limit to 200 characters): | |
| <p>Caterpillar Diesel fired Generator Set used to supply electrical power to crushing plant. Generator fired on No.2 virgin diesel fuel oil with a maximum sulfur content of 0.5% by weight, 138,000 BTU/gal and maximum fuel consumption at 25 gal/hr.</p> | |

**F. SEGMENT (PROCESS/FUEL) INFORMATION
(Regulated and Unregulated Emissions Units)**

Segment Description and Rate: Segment 1 of 1

| | |
|---|--|
| 1. Segment Description (Process/Fuel Type and Associated Operating Method/Mode) (limit to 500 characters): Eagle Crusher Company, Inc. – Portable Crushing Unit – Emissions from Caterpillar Generator Set fired on No.2 virgin diesel fuel oil with a sulfur limit of 0.5% by weight. | |
| 2. Source Classification Code (SCC): 20200401 | |
| 3. SCC Units: 1000 gallons burned | |
| 4. Maximum Hourly Rate: 25.0 gal/hr @ worst case scenario | 5. Maximum Annual Rate: 78,000 gal/yr @ max. |
| 6. Estimated Annual Activity Factor: 0.50 tpy @ worst case scenario at worst site. | |
| 7. Maximum Percent Sulfur: 0.50 % by weight | 8. Maximum Percent Ash: NEG. |
| 9. Million Btu per SCC Unit: 138.0 MMBtu/SCC Unit | |
| 10. Segment Comment (limit to 200 characters): | |

Segment Description and Rate: Segment of

| | |
|---|-------------------------|
| 1. Segment Description (Process/Fuel Type and Associated Operating Method/Mode) (limit to 500 characters): | |
| 2. Source Classification Code (SCC): | |
| 3. SCC Units: | |
| 4. Maximum Hourly Rate: | 5. Maximum Annual Rate: |
| 6. Estimated Annual Activity Factor: | |
| 7. Maximum Percent Sulfur: | 8. Maximum Percent Ash: |
| 9. Million Btu per SCC Unit: | |
| 10. Segment Comment (limit to 200 characters): | |

**G. EMISSIONS UNIT POLLUTANTS
(Regulated and Unregulated Emissions Units)**

| 1. Pollutant Emitted | 2. Primary Control Device Code | 3. Secondary Control Device Code | 4. Pollutant Regulatory Code |
|----------------------|--------------------------------|----------------------------------|------------------------------|
| TSP | None | None | EL |
| SO2 | None | None | EL |
| CO | None | None | EL |
| NOx | None | None | EL |
| TOC | None | None | EL |
| | | | |
| | | | |
| | | | |
| | | | |
| | | | |
| | | | |
| | | | |
| | | | |
| | | | |
| | | | |
| | | | |
| | | | |
| | | | |
| | | | |
| | | | |
| | | | |
| | | | |
| | | | |
| | | | |
| | | | |

**H. EMISSIONS UNIT POLLUTANT DETAIL INFORMATION
(Regulated Emissions Units Only - Emissions Limited Pollutants Only)**

Pollutant Detail Information: Pollutant 1 of 5

| |
|--|
| 1. Pollutant Emitted: PM₁₀ 2. <u> </u> |
| 2. Total Percent Efficiency of Control: NONE |
| 3. Potential Emissions: PM10 = 1.07 lb/hr or 1.67 ton/yr |
| 4. Synthetically Limited? <input checked="" type="checkbox"/> Yes <input type="checkbox"/> No |
| 5. Range of Estimated Fugitive/Other Emissions: <input type="checkbox"/> 1 <input type="checkbox"/> 2 <input type="checkbox"/> 3 <u> 0 </u> to <u> 0 </u> tons/year |
| 6. Emission Factor: 0.31 lbs/MMBTU Reference: AP-42 |
| 7. Emissions Method Code: <input type="checkbox"/> 0 <input type="checkbox"/> 1 <input type="checkbox"/> 2 <input checked="" type="checkbox"/> 3 <input type="checkbox"/> 4 <input type="checkbox"/> 5 |
| 8. Calculation of Emissions: $\text{PM}_{10} = (25 \text{ gal/hr fuel usage})(138,000 \text{ BTU/gal}) = 3.45 \text{ MMBTU/hr}$ $(3.45 \text{ MMBTU/hr})(0.31 \text{ lb/MMBTU}) = 1.07 \text{ lb/hr}$ $(1.07 \text{ lb/hr})(3120 \text{ hrs/yr}) / 2000 \text{ lb/ton} = 1.67 \text{ ton/hr}$ |
| 9. Pollutant Potential/Estimated Emissions Comment (limit to 200 characters): |

**H. EMISSIONS UNIT POLLUTANT DETAIL INFORMATION
(Regulated Emissions Units Only - Emissions Limited Pollutants Only)**

Pollutant Detail Information: Pollutant 2 of 5

| |
|--|
| 3. Pollutant Emitted: NO_x |
| 2. Total Percent Efficiency of Control: NONE |
| 3. Potential Emissions: NO_x = 15.21 lb/hr or 23.73 ton/yr |
| 4. Synthetically Limited? <input checked="" type="checkbox"/> Yes <input type="checkbox"/> No |
| 5. Range of Estimated Fugitive/Other Emissions: <input type="checkbox"/> 1 <input type="checkbox"/> 2 <input type="checkbox"/> 3 <u> 0 </u> to <u> 0 </u> tons/year |
| 6. Emission Factor: 4.41 lbs/MMBTU Reference: AP-42 |
| 7. Emissions Method Code: <input type="checkbox"/> 0 <input type="checkbox"/> 1 <input type="checkbox"/> 2 <input checked="" type="checkbox"/> 3 <input type="checkbox"/> 4 <input type="checkbox"/> 5 |
| 9. Calculation of Emissions: NO_x = (25 gal/hr fuel usage)(138,000 BTU/gal) = 3.45 MMBTU/hr (3.45 MMBTU/hr)(4.41 lb/MMBTU) = 15.21 lb/hr (15.21 lb/hr)(3120 hrs/yr) / 2000 lb/ton = 23.73 ton/hr |
| 9. Pollutant Potential/Estimated Emissions Comment (limit to 200 characters): |

**H. EMISSIONS UNIT POLLUTANT DETAIL INFORMATION
(Regulated Emissions Units Only - Emissions Limited Pollutants Only)**

Pollutant Detail Information: Pollutant 3 of 5

| |
|---|
| 1. Pollutant Emitted: CO |
| 2. Total Percent Efficiency of Control: NONE |
| 3. Potential Emissions: CO = 3.28 lb/hr or 5.12 ton/yr |
| 4. Synthetically Limited? <input checked="" type="checkbox"/> Yes <input type="checkbox"/> No |
| 5. Range of Estimated Fugitive/Other Emissions: <input type="checkbox"/> 1 <input type="checkbox"/> 2 <input type="checkbox"/> 3 <u>0</u> to <u>0</u> tons/year |
| 6. Emission Factor: 0.95 lbs/MMBTU Reference: AP-42 |
| 7. Emissions Method Code: <input type="checkbox"/> 0 <input type="checkbox"/> 1 <input type="checkbox"/> 2 <input checked="" type="checkbox"/> 3 <input type="checkbox"/> 4 <input type="checkbox"/> 5 |
| 10. Calculation of Emissions: CO = (25 gal/hr fuel useage)(138,000 BTU/gal) = 3.45 MMBTU/hr (3.45 MMBTU/hr)(0.95 lb/MMBTU) = 3.28 lb/hr (3.28 lb/hr)(3120 hrs/yr) / 2000 lb/ton = 5.12 ton/hr |
| 9. Pollutant Potential/Estimated Emissions Comment (limit to 200 characters): |

**H. EMISSIONS UNIT POLLUTANT DETAIL INFORMATION
(Regulated Emissions Units Only - Emissions Limited Pollutants Only)**

Pollutant Detail Information: Pollutant 1 of 5

| |
|--|
| 1. Pollutant Emitted: Sox |
| 2. Total Percent Efficiency of Control: NONE |
| 3. Potential Emissions: Sox = 1.00 lb/hr or 1.56 ton/yr |
| 4. Synthetically Limited? <input checked="" type="checkbox"/> Yes <input type="checkbox"/> No |
| 5. Range of Estimated Fugitive/Other Emissions: <input type="checkbox"/> 1 <input type="checkbox"/> 2 <input type="checkbox"/> 3 <u>0</u> to <u>0</u> tons/year |
| 6. Emission Factor: 0.29 lbs/MMBTU Reference: AP-42 |
| 7. Emissions Method Code: <input type="checkbox"/> 0 <input type="checkbox"/> 1 <input type="checkbox"/> 2 <input checked="" type="checkbox"/> 3 <input type="checkbox"/> 4 <input type="checkbox"/> 5 |
| 11. Calculation of Emissions: SOx = (25 gal/hr fuel useage)(138,000 BTU/gal) = 3.45 MMBTU/hr (3.45 MMBTU/hr)(0.29 lb/MMBTU) = 1.00 lb/hr (1.00 lb/hr)(3120 hrs/yr) / 2000 lb/ton = 1.56 ton/hr |
| 9. Pollutant Potential/Estimated Emissions Comment (limit to 200 characters): |

**H. EMISSIONS UNIT POLLUTANT DETAIL INFORMATION
(Regulated Emissions Units Only - Emissions Limited Pollutants Only)**

Pollutant Detail Information: Pollutant 5 of 5

| |
|--|
| 1. Pollutant Emitted: TOC |
| 2. Total Percent Efficiency of Control: NONE |
| 3. Potential Emissions: TOC = 1.24 lb/hr or 1.93 ton/yr |
| 4. Synthetically Limited? <input checked="" type="checkbox"/> Yes <input type="checkbox"/> No |
| 5. Range of Estimated Fugitive/Other Emissions: <input type="checkbox"/> 1 <input type="checkbox"/> 2 <input type="checkbox"/> 3 <u>0</u> to <u>0</u> tons/year |
| 6. Emission Factor: 0.36 lbs/MMBTU Reference: AP-42 |
| 7. Emissions Method Code: <input type="checkbox"/> 0 <input type="checkbox"/> 1 <input type="checkbox"/> 2 <input checked="" type="checkbox"/> 3 <input type="checkbox"/> 4 <input type="checkbox"/> 5 |
| 12. Calculation of Emissions: TOC = (25 gal/hr fuel useage)(138,000 BTU/gal) = 3.45 MMBTU/hr (3.45 MMBTU/hr)(0.36 lb/MMBTU) = 1.24 lb/hr (1.24 lb/hr)(3120 hrs/yr) / 2000 lb/ton = 1.93 ton/hr |
| 9. Pollutant Potential/Estimated Emissions Comment (limit to 200 characters): |

Allowable Emissions (Pollutant identified on front of page)

A.

| | | |
|---|---------|-----------|
| 1. Basis for Allowable Emissions Code: This facility will be subject to 40 CFR Part 60, Subpart 000 rules and regulations. | | |
| 2. Future Effective Date of Allowable Emissions: Initial Visible Emissions Compliance Test | | |
| 3. Requested Allowable Emissions and Units: < 20% Opacity | | |
| 4. Equivalent Allowable Emissions: | lb/hour | tons/year |
| 5. Method of Compliance (limit to 60 characters): Annual EPA Method 9 Compliance Testing. | | |
| 6. Pollutant Allowable Emissions Comment (Desc. of Related Operating Method/Mode) (limit to 200 characters): | | |

B.

| | | |
|---|-------|-----------|
| 1. Basis for Allowable Emissions Code: | | |
| 2. Future Effective Date of Allowable Emissions: | | |
| 3. Requested Allowable Emissions and Units: | | |
| 4. Equivalent Allowable Emissions: | lb/hr | tons/year |
| 5. Method of Compliance (limit to 60 characters): | | |
| 6. Pollutant Allowable Emissions Comment (Desc. of Related Operating Method/Mode) (limit to 200 characters): | | |

**I. VISIBLE EMISSIONS INFORMATION
(Regulated Emissions Units Only)**

Visible Emissions Limitation: Visible Emissions Limitation 1 of 1

| |
|---|
| 1. Visible Emissions Subtype: VE |
| 2. Basis for Allowable Opacity: <input checked="" type="checkbox"/> Rule <input type="checkbox"/> Other |
| 3. Requested Allowable Opacity: Normal Conditions: < 5 % Exceptional Conditions: < 5 % Maximum Period of Excess Opacity Allowed: 0 min/hour |
| 4. Method of Compliance: Annual EPA Method 9 visible emission testing. |
| 5. Visible Emissions Comment (limit to 200 characters): |

Visible Emissions Limitation: Visible Emissions Limitation of

| |
|---|
| 1. Visible Emissions Subtype: |
| 2. Basis for Allowable Opacity: <input type="checkbox"/> Rule <input type="checkbox"/> Other |
| 3. Requested Allowable Opacity: Normal Conditions: % Exceptional Conditions: % Maximum Period of Excess Opacity Allowed: min/hour |
| 4. Method of Compliance: |
| 5. Visible Emissions Comment (limit to 200 characters): |

J. CONTINUOUS MONITOR INFORMATION
(Regulated Emissions Units Only)

Continuous Monitoring System: Continuous Monitor _____ of _____

| | |
|---|--|
| 1. Parameter Code: NOT APPLICABLE | 2. Pollutant(s): |
| 3. CMS Requirement: | <input type="checkbox"/> Rule <input type="checkbox"/> Other |
| 4. Monitor Information: Manufacturer: Model Number: | Serial Number: |
| 5. Installation Date: | |
| 6. Performance Specification Test Date: | |
| 7. Continuous Monitor Comment (limit to 200 characters): NOT APPLICABLE | |

Continuous Monitoring System: Continuous Monitor _____ of _____

| | |
|---|--|
| 1. Parameter Code: | 2. Pollutant(s): |
| 3. CMS Requirement: | <input type="checkbox"/> Rule <input type="checkbox"/> Other |
| 4. Monitor Information: Manufacturer: Model Number: | Serial Number: |
| 5. Installation Date: | |
| 6. Performance Specification Test Date: | |
| 7. Continuous Monitor Comment (limit to 200 characters): | |

**K. PREVENTION OF SIGNIFICANT DETERIORATION (PSD) INCREMENT
TRACKING INFORMATION
(Regulated and Unregulated Emissions Units)**

PSD Increment Consumption Determination

1. Increment Consuming for Particulate Matter or Sulfur Dioxide?

If the emissions unit addressed in this section emits particulate matter or sulfur dioxide, answer the following series of questions to make a preliminary determination as to whether or not the emissions unit consumes PSD increment for particulate matter or sulfur dioxide. Check the first statement, if any, that applies and skip remaining statements.

-] The emissions unit is undergoing PSD review as part of this application, or has undergone PSD review previously, for particulate matter or sulfur dioxide. If so, emissions unit consumes increment.
-] The facility addressed in this application is classified as an EPA major source pursuant to paragraph (c) of the definition of "major source of air pollution" in Chapter 62-213, F.A.C., and the emissions unit addressed in this section commenced (or will commence) construction after January 6, 1975. If so, baseline emissions are zero, and emissions unit consumes increment.
-] The facility addressed in this application is classified as an EPA major source, and the emissions unit began initial operation after January 6, 1975, but before December 27, 1977. If so, baseline emissions are zero, and emissions unit consumes increment.
-] For any facility, the emissions unit began (or will begin) initial operation after December 27, 1977. If so, baseline emissions are zero, and emissions unit consumes increment.
-] None of the above apply. If so, the baseline emissions of the emissions unit are nonzero. In such case, additional analysis, beyond the scope of this application, is needed to determine whether changes in emissions have occurred (or will occur) after the baseline date that may consume or expand increment.

Emissions Unit Information Section 9 of 9

2. Increment Consuming for Nitrogen Dioxide?

If the emissions unit addressed in this section emits nitrogen oxides, answer the following series of questions to make a preliminary determination as to whether or not the emissions unit consumes PSD increment for nitrogen dioxide. Check first statement, if any, that applies and skip remaining statements.

-] The emissions unit addressed in this section is undergoing PSD review as part of this application, or has undergone PSD review previously, for nitrogen dioxide. If so, emissions unit consumes increment.
-] The facility addressed in this application is classified as an EPA major source pursuant to paragraph (c) of the definition of "major source of air pollution" in Chapter 62-213, F.A.C., and the emissions unit addressed in this section commenced (or will commence) construction after February 8, 1988. If so, baseline emissions are zero, and emissions unit consumes increment.
-] The facility addressed in this application is classified as an EPA major source, and the emissions unit began initial operation after February 8, 1988, but before March 28, 1988. If so, baseline emissions are zero, and emissions unit consumes increment.
-] For any facility, the emissions unit began (or will begin) initial operation after March 28, 1988. If so, baseline emissions are zero, and emissions unit consumes increment.
-] None of the above apply. If so, the baseline emissions of the emissions unit are nonzero. In such case, additional analysis, beyond the scope of this application, is needed to determine whether changes in emissions have occurred (or will occur) after the baseline date that may consume or expand increment.

| | | | |
|---|------------------------------|------------------------------|---|
| 3. Increment Consuming/Expanding Code: | | | |
| PM | <input type="checkbox"/>] C | <input type="checkbox"/>] E | <input checked="" type="checkbox"/>] Unknown |
| SO2 | <input type="checkbox"/>] C | <input type="checkbox"/>] E | <input checked="" type="checkbox"/>] Unknown |
| NO2 | <input type="checkbox"/>] C | <input type="checkbox"/>] E | <input checked="" type="checkbox"/>] Unknown |
| 4. Baseline Emissions: | | | |
| PM ₁₀ / TSP | 1.07 lb/hour | 1.67 tons/year | |
| SO2 | 1.00 lb/hour | 1.56 tons/year | |
| NO2 | 15.21 lb/hr | 23.73 tons/year | |
| 5. PSD Comment (limit to 200 characters): | | | |
| | | | |

**L. EMISSIONS UNIT SUPPLEMENTAL INFORMATION
(Regulated Emissions Units Only)**

Supplemental Requirements for All Applications

| |
|---|
| <p>1. Process Flow Diagram <input checked="" type="checkbox"/> Attached, Document ID: <u> III </u> [] Not Applicable [] Waiver Requested</p> |
| <p>2. Fuel Analysis or Specification <input type="checkbox"/> Attached, Document ID: _____ [] Not Applicable [] Waiver Requested</p> |
| <p>3. Detailed Description of Control Equipment <input checked="" type="checkbox"/> Attached, Document ID: <u> V </u> [] Not Applicable [] Waiver Requested</p> |
| <p>4. Description of Stack Sampling Facilities <input type="checkbox"/> Attached, Document ID: _____ <input checked="" type="checkbox"/> Not Applicable [] Waiver Requested</p> |
| <p>5. Compliance Test Report <input type="checkbox"/> Attached, Document ID: _____ <input type="checkbox"/> Previously submitted, Date: _____ <input checked="" type="checkbox"/> Not Applicable</p> |
| <p>6. Procedures for Startup and Shutdown <input type="checkbox"/> Attached, Document ID: _____ <input checked="" type="checkbox"/> Not Applicable</p> |
| <p>7. Operation and Maintenance Plan <input checked="" type="checkbox"/> Attached, Document ID: <u> VI </u> [] Not Applicable</p> |
| <p>8. Supplemental Information for Construction Permit Application <input checked="" type="checkbox"/> Attached, Document ID: <u> VII </u> <input checked="" type="checkbox"/> Not Applicable</p> |
| <p>9. Other Information Required by Rule or Statute <input type="checkbox"/> Attached, Document ID: _____ <input checked="" type="checkbox"/> Not Applicable</p> |

Additional Supplemental Requirements for Category I Applications Only

| |
|--|
| 10. Alternative Methods of Operation <input type="checkbox"/> Attached, Document ID: _____ <input checked="" type="checkbox"/> Not Applicable |
| 11. Alternative Modes of Operation (Emissions Trading) <input type="checkbox"/> Attached, Document ID: _____ <input checked="" type="checkbox"/> Not Applicable |
| 12. Identification of Additional Applicable Requirements <input type="checkbox"/> Attached, Document ID: _____ <input checked="" type="checkbox"/> Not Applicable |
| 13. Compliance Assurance Monitoring Plan <input type="checkbox"/> Attached, Document ID: _____ <input checked="" type="checkbox"/> Not Applicable |
| 14. Acid Rain Application (Hard-copy Required) <input type="checkbox"/> Acid Rain Part - Phase II (Form No. 62-210.900(1)(a)) Attached, Document ID: _____ <input type="checkbox"/> Repowering Extension Plan (Form No. 62-210.900(1)(a)1.) Attached, Document ID: _____ <input type="checkbox"/> New Unit Exemption (Form No. 62-210.900(1)(a)2.) Attached, Document ID: _____ <input type="checkbox"/> Retired Unit Exemption (Form No. 62-210.900(1)(a)3.) Attached, Document ID: _____ <input checked="" type="checkbox"/> Not Applicable |

TABLE OF CONTENTS

- I. FACILITY LOCATION**
- II. SITE PLAN**
- III. FLOW DIAGRAM**
- IV. TYPICAL FUEL ANALYSIS - GENSET**
- V. CONTROL EQUIPMENT**
- VI. O & M PLAN**
- VII. SUPPLEMENTAL INFORMATION**

I. FACILITY LOCATION

White Rock Quarries

Portable Bohringer Crushing Unit - Home Base

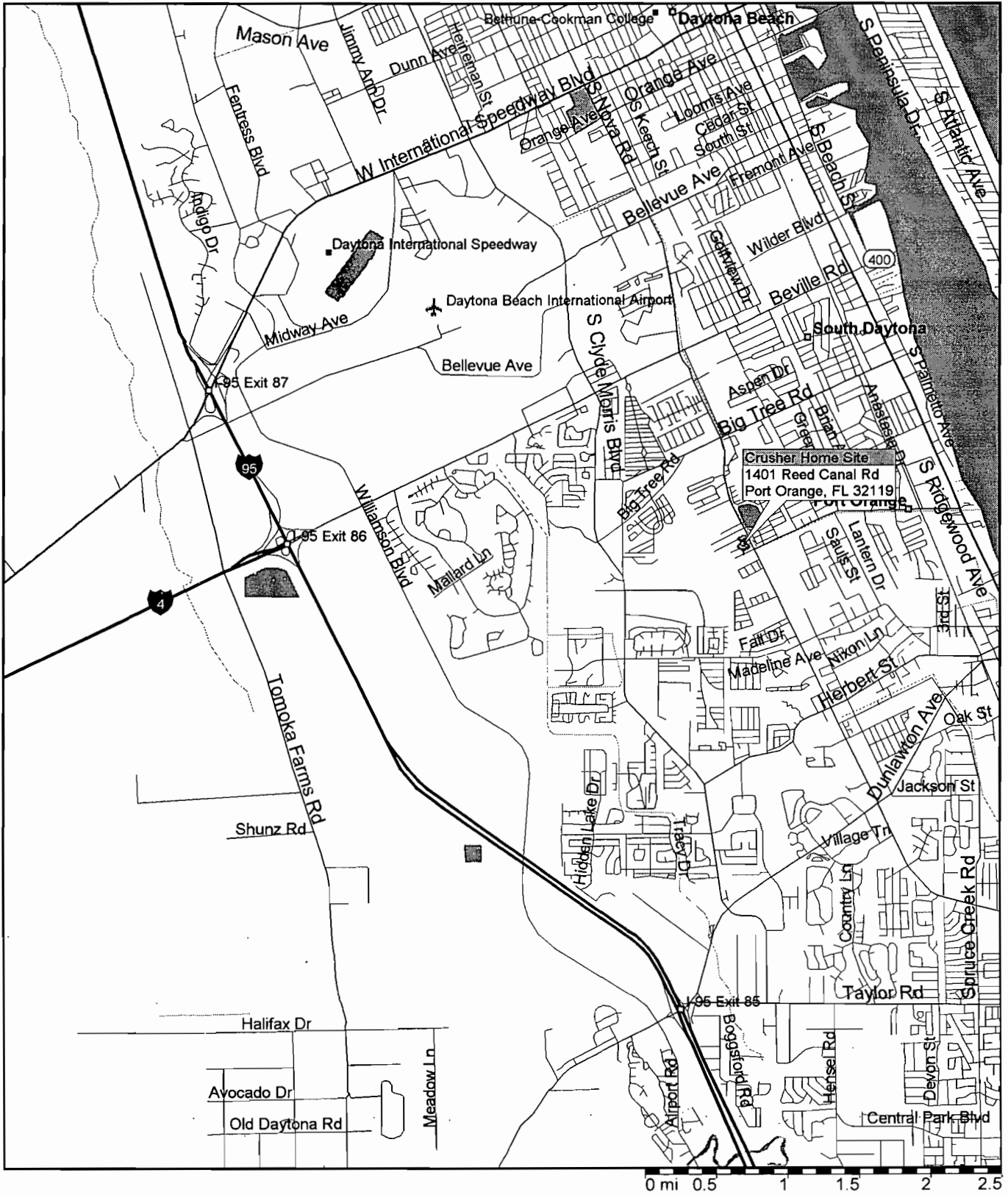

Microsoft Expedia
Streets98

II. SITE PLAN

Typical Plot Plan

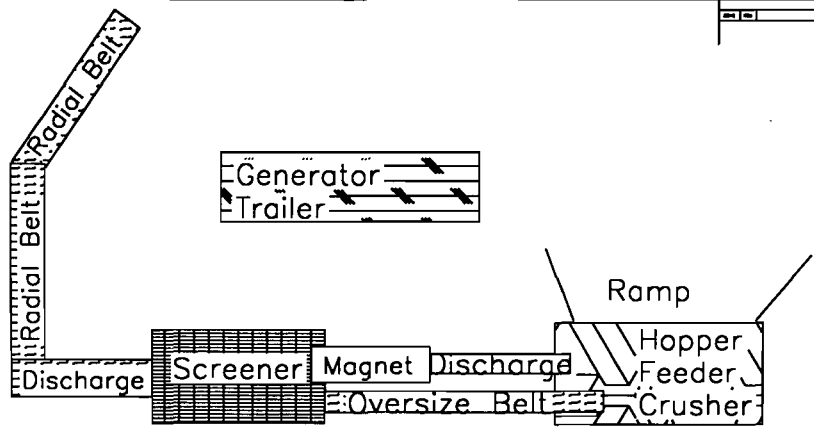

Aggregate Piles

Typical Asphalt Plant

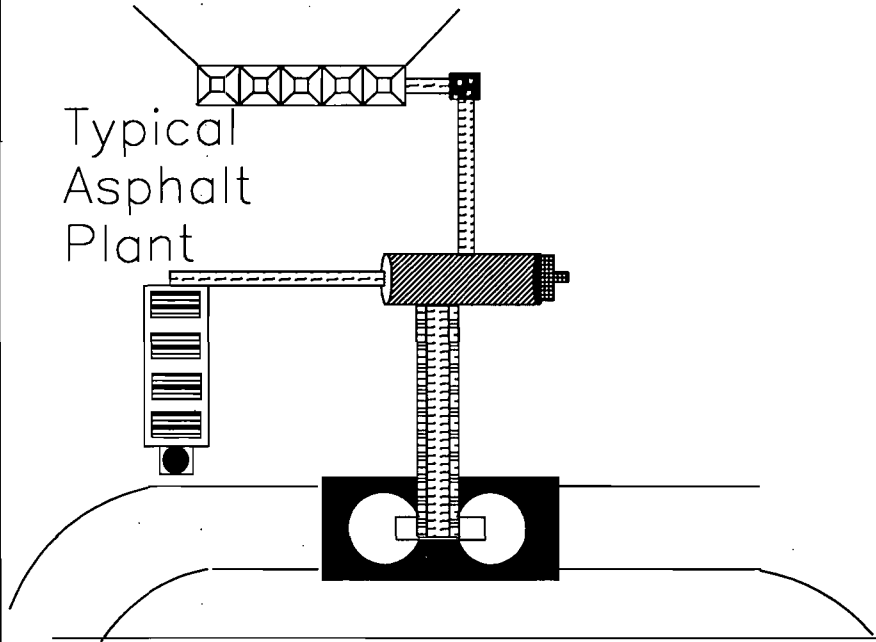

Office

| | | |
|-----------|-------------------------------------|----------|
| | CENTRAL FLORIDA TESTING LABS., INC. | |
| | White Rock Quarries | |
| Plot Plan | DATE | SCALE |
| | | 1" = 10' |

III. FLOW DIAGRAM

White Rock Quarries - Portable Bohringer Reclaimed Aggregate Crushing & Screening - Plant Flow Diagram

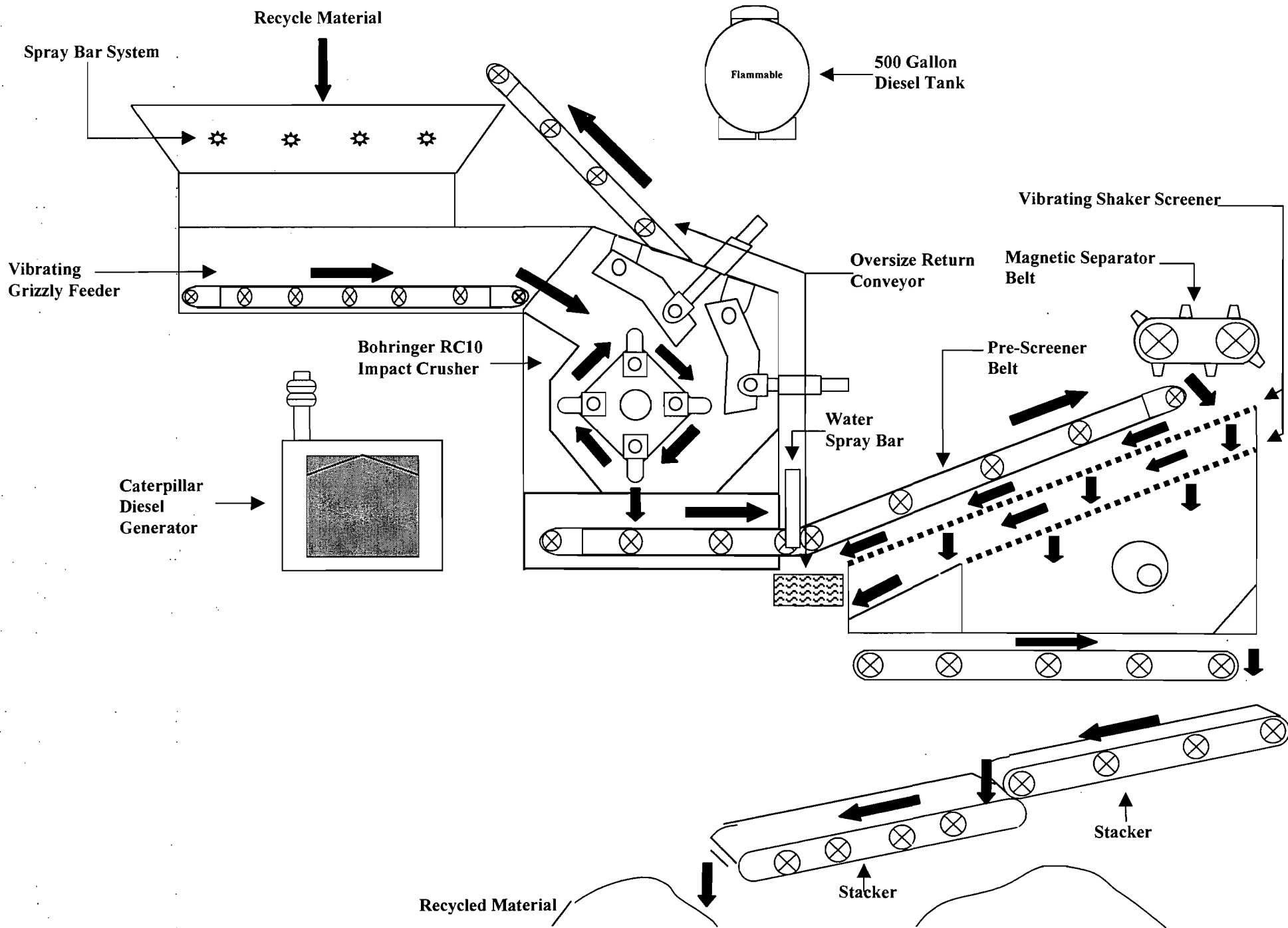

PROCESS DESCRIPTION

This project consists of a portable secondary crushing plant that will be utilized to recycle reclaimed concrete and asphalt material at various sites throughout the state of Florida, for reuse in asphalt plants, as base material and fill by contracting companies and for sale to the general public.

The process begins with the transfer of reclaimed concrete and asphalt material that has been scalped or excavated from highways, parking lots, building demolition, etc. is brought to any of this company's clients facilities by dump truck and stockpiled for crushing. The client then contacts White Rock Quarries and the crushing unit is brought to the site of where the material has been stockpiled for crushing. This stockpiled material, usually in chunk form ranging from one to twenty inches in diameter contains very little if any fine material and therefore is virtually dust free. This material is too large to reuse in it's reclaimed size, so it has to be screened and crushed to various practical aggregate sizes. The reclaimed concrete is transferred from it's stockpiles by a front-end-loader into the vibrating grizzly feeder hopper. From this hopper the reclaimed material vibrates into the crusher where it is crushed to a desired size and drops onto the discharge pan below the crusher. This crushed material is then transferred by conveyor belt to a metal extractor that removes any metal that may have been within the reclaimed material. After passing the metal extractor the material is then dropped to vibrating screening system. Once the material reaches and drops onto the vibrating screening system any over size material is transferred back to the crusher by conveyor, whereas the material that passes through several screens and is dropped onto a transfer conveyor then to radialstacker belts that stockpiles the material for reuse at a later time.

The majority of fugitive dust created during this process is generated by the vibrating feeder hopper and the impact - crusher and at the drop point below the crusher. These emission points as well as all transfer and if needed drop points throughout the plant will be controlled by a self-made water spray bar / spray head dust suppression system that employs spray bars and spray heads at the various emission points throughout the plant were deemed necessary.

Any fugitives generated by vehicular traffic, winds and airborne particulate from stockpiles will be the responsibility of the property owner and will be controlled as stated in the specific conditions of their FDEP Operation Permit..

This facility will comply with all FDEP Rules and Regulations referencing portable crushing plants of this type.

IV. TYPICAL FUEL ANALYSIS
Diesel Fired Generator

REPORT OF LABORATORY ANALYSIS

LAB NO, ML 8504

SAMPLE MARKED: STK 407 after "Mekhanik Yumya"

SAMPLE DATE: 10-27-98

REPORT DATE: 10-27-98

LOCATION: Coastal Refining & Marketing, Inc. - Port Manatee

SAMPLE SUBMITTED BY: Intertek Caleb Brett

SAMPLE DESCRIPTION: DIESEL HIGH SULFUR

| TEST | METHOD | RESULT |
|---------------------------|--------|----------|
| API GRAVITY AT 60 F | D1298 | 33.3 |
| ACID NO. | D974 | ----- |
| DENSITY, kg/L AT 15 C | D1298 | 858.2 |
| FLASH PT, F, PMCC | D93 | 172 |
| SEDIMENT & WATER, VOL. % | D2709 | 0 |
| VISCOSITY AT 40 C cSt | D445 | 3.77 |
| VISCOSITY AT 122 F, cSt | D445 | 3.05 |
| S.U.S. VISCOSITY AT 100 F | D445 | 39.1 |
| CLOUD PT., F | D2500 | +10 |
| POUR POINT, F | D97 | 0 |
| SULFUR, WT. % | D4294 | 0.27 |
| ASH, WT. % | D482 | 0.001 |
| APPEARANCE | D4176 | 1-pass |
| B.T.U./ GAL. HHV/ | D240 | 139953 |
| DYE, PPM/PTB | DT-100 | 12.3/4.3 |
| NITROGEN, PPM | D4629 | ----- |
| COMPATIBILITY, SPOT NO. | D4740 | ----- |
| CORROSION, COPPER | D130 | 1a- |
| CCR 10% BOTTOMS WT. % | D189 | 0.05 |
| CETANE INDEX, CALCULATED | D976 | 48 |
| PARTICULATES, mg/L | D2276 | 7.7 |
| ACCELERATED STABILITY | D2274 | ----- |
| DuPONT STABILITY | DuPont | 2 |
| DISTILLATION, IBP | D86 | 380 |
| 10% RECOVERED | D86 | 460 |
| 50% RECOVERED | D86 | 546 |
| 90% RECOVERED | D86 | 630 |
| FINAL BOILING POINT | D86 | 688 |
| RECOVERY | D86 | 99.0 |
| RESIDUE | D86 | 1.0 |
| LOSS | D86 | 0.0 |
| TRACE METALS | AA | |
| ALUMINUM, PPM | | <0.1 |
| CALCIUM, PPM | | <0.1 |
| LEAD, PPM | | <0.1 |
| SODIUM, PPM | | <0.1 |
| VANADIUM, PPM | | <0.1 |

BY Marie Calhoon
MARIE F. CALHOON, CHEMIST

V. CONTROL EQUIPMENT

CONTROL EQUIPMENT

All of the equipment used to control fugitive dust emissions from this crushing unit will be generated by crushing and maintenance personnel on as needed basis as this crushing unit did not come equipped with any dust suppression equipment when purchased.

The water spray bar and spray head system used on this equipment were manufactured and installed on areas where possible fugitive dust emissions would occur during the crushing, screening and conveying operations.

The control process starts with an on site water truck or pond that is equipped an electric pump (only one used at a time as one is a spare) that is used to feed water through 1 1/2 inch PVC pipe to a hose bib rack. From the hose bib rack water is fed through either 1/2 PVC piping or 1/2 inch hose to spray heads and bars mounted at the various fugitive emission points mentioned above at 25-40 psi, depending what is needed to control the emissions. Water is usually obtained from various sources such as on site water supplies, fire hydrant, lakes, ponds or a clients water truck.

In addition, as deemed necessary, plant personnel will dampen uncrushed stockpiles of uncrushed material to control any fugitive emissions generated.

OPERATING PARAMETERS
for
SELF-MADE WATER SPRAY BAR / SPRAY HEAD
DUST SUPPRESSION SYSTEM

Water Pressure to Spray Bars & Spray Heads 20-45 psi @ each head
Operation Mode Continuous w/ product

VI. O & M PLAN

General Maintenance Intervals

The crushing unit is checked daily for visible emissions. If any fugitive emissions are seen escaping the crushing plant the source is identified immediately and the problem area is corrected. Fugitive emissions at drop points are controlled by increasing and decreasing the water pressure as needed, from 25-40 psi, at the spray bars/heads.

Inspections of various parts of the Self-Made Water Spray Bar / Spray Head Dust Suppression System are done on a daily basis before startup, during operation and after shut down, as well as complete inspection on a weekly basis. If anything is found broken, not functioning or out of the ordinary it is fixed immediately by trained plant personnel.

Operations and Maintenance Schedule
White Rock Quarries - Portable Bohringer Crushing Unit
Portable Crushing Unit w/ Self-made Water Spray Bar Dust Suppression System

| Maintenance to be performed: | Daily | Weekly | Monthly | Yearly |
|--|-------|--------|---------|--------|
| Check Crushing Unit and Conveyors for escaping fugitive emissions. | X | | | |
| Check spray bars for operation. | X | | | |
| Check water piping system for leaks. | | X | | |
| Make sure yard & stockpiles are being dampened. | X | | | |
| Check all belts and pulleys for wear. | | | X | |
| Check water flow through spray nozzles. | X | | | |
| Check spray heads for effective operation. | X | | | |
| Check entire water spray bar system for wear & deterioration. | | | X | |
| Check spray head patterns for effective operation. | | X | | |
| Check plant for wear & deterioration. | | | X | X |
| Grease all fittings & bearings. | | X | | |
| Flush and cleanout water spray bar dust suppression system. | | | X | |
| Check screens and brushes for wear. | | | X | |
| Check all conveyor belts for wear. | | X | | |
| Check that all spray bars on water truck operating properly. | X | | | |
| Check backup water hoses for operation. | | X | | |
| Check electrical system of plant. | | X | | |
| Check emergency shut down switches for operation. | | X | | |

OPERATING PARAMETERS
for
SELF-MADE WATER SPRAY BAR DUST SUPPRESSION SYSTEM

**Water Pressure to Spray Bars & Spray Heads
Operation Mode**

**25-45 psi
Continuous w/product**

Spare Parts on Site:

- 1) Extra spray nozzles**
- 2) Hose mending Materials**
- 3) Extra Hose Material**
- 4) Hose Fittings**
- 5) Extra Backup Hoses**
- 6) Spare Parts and Spray Heads**

VII. SUPPLEMENTAL INFORMATION

BEST AVAILABLE COPY

BÖHRINGER

Impact Crushers – Recycling –

„RC” Series for Asphalt, Concrete with wire mesh/rebar and Building rubble

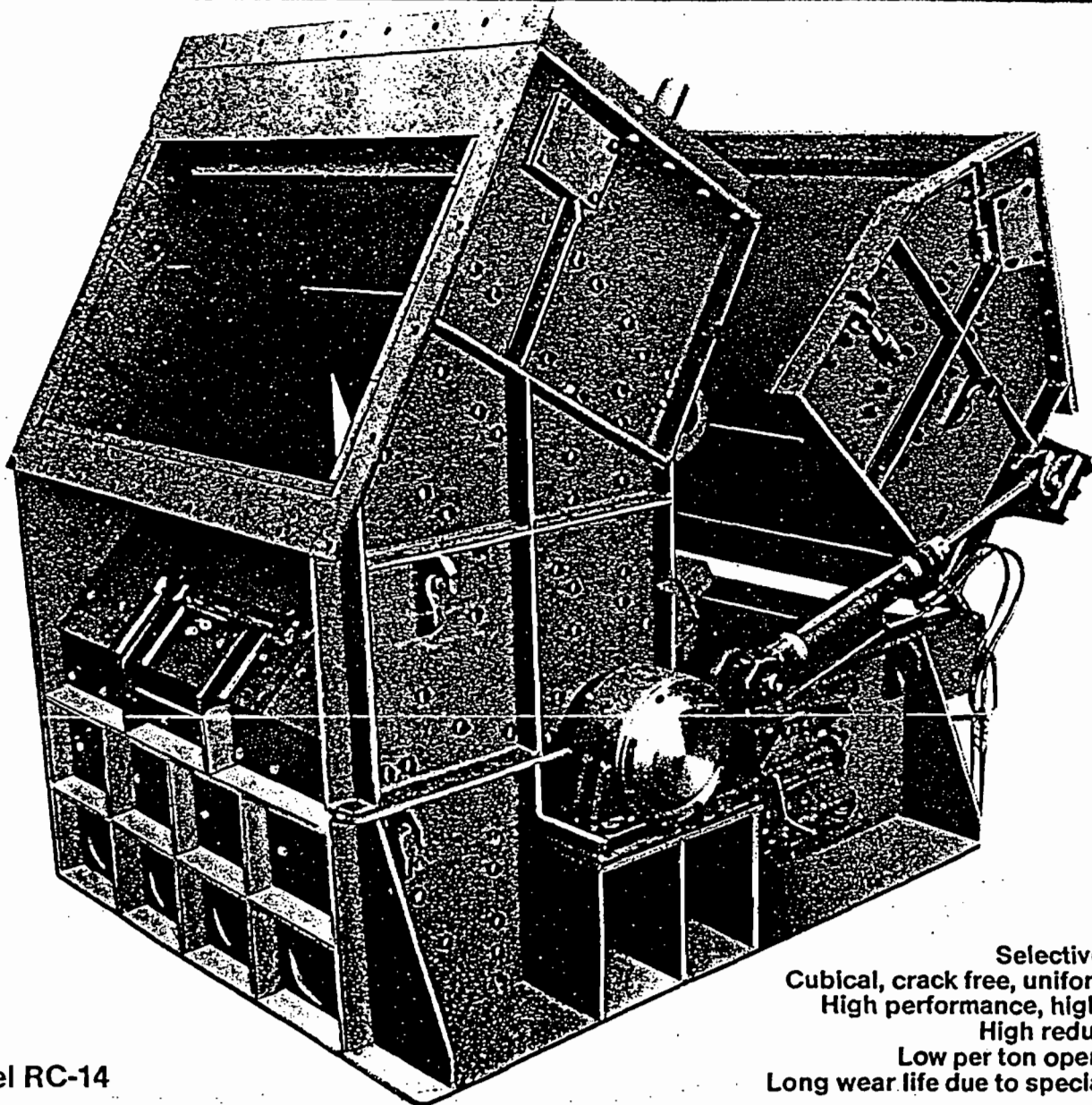

Model RC-14

Selective crushing.
Cubical, crack free, uniform product.
High performance, high capacity.
High reduction ratio.
Low per ton operating cost.
Long wear life due to special castings.

Impact crushers „RC” series – Recycling –

- Increase your profits
- save energy
- lower your maintenance cost and down-time
- eliminate multi-stage crushing
- conserve raw material resources
- eliminate dumping costs

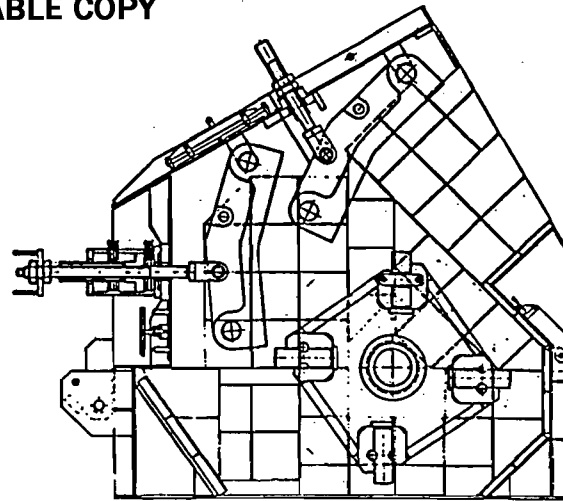

Model RC 14

| Model | Rotor Dia. (Inch) Width | Feed Opening (Inch) | Capacity (Stph) | Power required (Hp) | Weight approx. (Lbs) |
|-------|----------------------------|------------------------|--------------------|------------------------|-------------------------|
| RC 18 | 59 x 70 | 71 x 47 | 300 - 400 | 300 - 500 | 88,700 |
| RC 16 | 49 1/4 x 63 | 64 x 39 | 275 - 350 | 250 - 400 | 59,200 |
| RC 14 | 49 1/4 x 55 15/16 | 57 x 37 | 175 - 275 | 200 - 350 | 41,700 |
| RC 12 | 47 1/4 x 47 1/4 | 48 x 37 | 150 - 250 | 175 - 300 | 35,800 |
| RC 10 | 43 5/16 x 41 3/8 | 42 x 31 | 100 - 175 | 125 - 200 | 29,800 |
| RC 7 | 39 3/8 x 27 9/16 | 28 x 20 | 50 - 100 | 75 - 125 | 18,100 |

Design specifications subject to change without notice. Technical data are approximates and should be used as a guide only. Capacity and power requirements depend on the type and characteristics of the feed material.

With the "RC"-series Boehringer offers a specially developed robust impact crusher for the recycling of asphalt, concrete (with mesh and rebar), building rubble and aggregates. The innovative design features, use of high wear resistant castings and utilization factor of the wear parts make this horizontal shaft, fixed blow bar impactor superior to any crusher of this type available today. Depending on the specific application the machine can be equipped with different interior parts. Access to the machine for inspection and/or maintenance is simplified through hydraulic opening of the upper rear housing section. The heavy duty rotor, the heart of any impact crusher, is equipped with four rows of blow bars made of high wear resistant castings. The two impact aprons are symmetric, single piece castings, reversible and interchangeable. Dependent on the application, we also offer aprons with replaceable impact plates. Their

special suspension assures minimum down-time for turning or replacing. Both aprons are gravity hung, adjustable towards the blow bars, to maintain a constant gap and thus assure a uniform product size. Spindle assemblies permit gap adjustment hydraulically on the lower (rear) apron. The crusher housing is lined with bolted, interchangeable wear plates of high wear resistant steel. The machine can be furnished with a tower crane, mounted to the feed hood, to assist with maintenance.

We offer consulting, application engineering of individual machinery and complete plants, such as:

- Stationary processing plant
- Portable recycling plant
- Modular skid mounted plant

BÖHRINGER

Impact Crushers – Recycling –

„RC” Series for Asphalt, Concrete with wire mesh/rebar and Building rubble

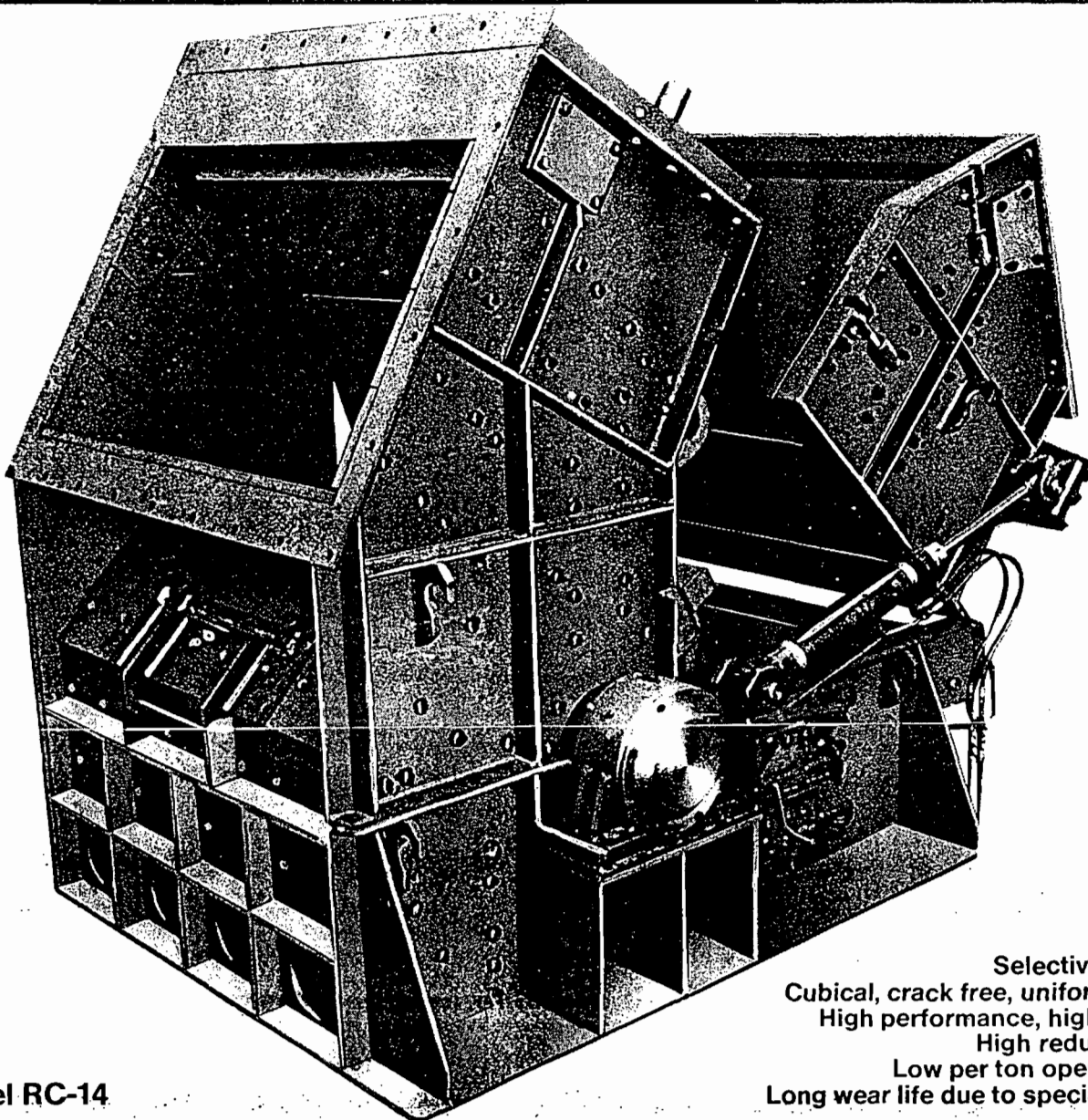

Model RC-14

Selective crushing.
Cubical, crack free, uniform product.
High performance, high capacity.
High reduction ratio.
Low per ton operating cost.
Long wear life due to special castings.

BÖHRINGER

Impact crushers „RC” series – Recycling –

- increase your profits
- save energy
- lower your maintenance cost and down-time
- eliminate multi-stage crushing
- conserve raw material resources
- eliminate dumping costs

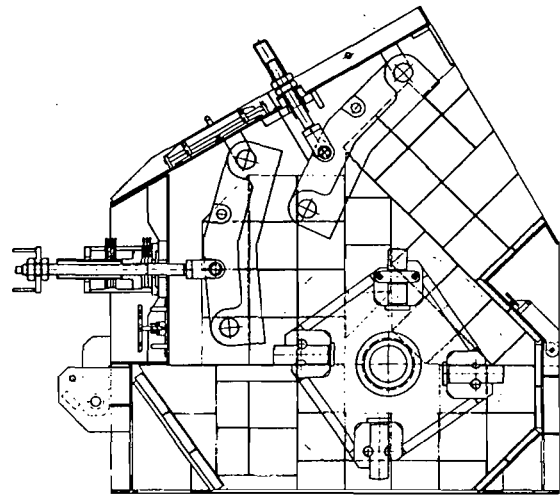

Model RC 14

| Model | Rotor Dia. (Inch) Width | Feed Opening (Inch) | Capacity (Stph) | Power required (Hp) | Weight approx. (Lbs) |
|-------|--------------------------------------|------------------------|--------------------|------------------------|-------------------------|
| RC 18 | 59x70 | 71 x 47 | 300 – 400 | 300 – 500 | 88,700 |
| RC 16 | 49 $\frac{1}{4}$ x63 | 64 x 39 | 275 – 350 | 250 – 400 | 59,200 |
| RC 14 | 49 $\frac{1}{4}$ x55 $\frac{15}{16}$ | 57 x 37 | 175 – 275 | 200 – 350 | 41,700 |
| RC 12 | 47 $\frac{1}{4}$ x47 $\frac{1}{4}$ | 48 x 37 | 150 – 250 | 175 – 300 | 35,800 |
| RC 10 | 43 $\frac{5}{16}$ x41 $\frac{3}{8}$ | 42 x 31 | 100 – 175 | 125 – 200 | 29,800 |
| RC 7 | 39 $\frac{3}{8}$ x27 $\frac{9}{16}$ | 28 x 20 | 50 – 100 | 75 – 125 | 18,100 |

Design specifications subject to change without notice. Technical data are approximates and should be used as a guide only. Capacity and power requirements depend on the type and characteristics of the feed material.

With the “RC”-series Boehringer offers a specially developed robust impact crusher for the recycling of asphalt, concrete (with mesh and rebar), building rubble and aggregates. The innovative design features, use of high wear resistant castings and utilization factor of the wear parts make this horizontal shaft, fixed blow bar impactor superior to any crusher of this type available today. Depending on the specific application the machine can be equipped with different interior parts. Access to the machine for inspection and/or maintenance is simplified through hydraulic opening of the upper rear housing section. The heavy duty rotor, the heart of any impact crusher, is equipped with four rows of blow bars made of high wear resistant castings. The two impact aprons are symmetric, single piece castings, reversible and interchangeable. Dependent on the application, we also offer aprons with replaceable impact plates. Their

special suspension assures minimum down-time for turning or replacing. Both aprons are gravity hung, adjustable towards the blow bars, to maintain a constant gap and thus assure a uniform product size. Spindle assemblies permit gap adjustment hydraulically on the lower (rear) apron. The crusher housing is lined with bolted, interchangeable wear plates of high wear resistant steel. The machine can be furnished with a tower crane, mounted to the feed hood, to assist with maintenance.

We offer consulting, application engineering of individual machinery and complete plants, such as:

Stationary processing plant

Portable recycling plant

Modular skid mounted plant.

LINDER INDUSTRIAL MACHINERY COMPANY

Statewide To Serve You Better

"Sealing"

cc: Mr. Dan Sherman, LIMCO
Mr. Jim Teague, LIMCO
QUOTATION
Mr. Jeff Chandler, LIMCO

401 S. Frontage Rd.
Tallahassee, Florida 32305
(813) 754-2727

20900 Taft Street
Pembroke Pines, Florida 33029
(305) 433-2800

718 North Lane Avenue
Jacksonville, Florida 32254
(904) 786-6710

2289 Bruner Lane S.E.
Fort Myers, Florida 33912
(813) 481-2403

3950 West Hwy 326
Ocala, Florida 32675
(904) 629-7585

1400 S. Orange Blossom Trail
Orlando, Florida 32805
(407) 849-6560

TO Mr. Jim Thompson
S & E Contractors, Inc.
14561 58th Street North
Clearwater, Florida 34620

REFERENCE Linder Proposal #4005,
Revision #1

DATE January 30, 1994

GENTLEMEN:

LINDER INDUSTRIAL MACHINERY COMPANY HEREBY SUBMITS TO YOU THE FOLLOWING QUOTATION ON THE GOODS LISTED BELOW SUBJECT TO ALL THE TERMS PRINTED ON THE REVERSE HEREOF. ALL OF WHICH ARE HEREBY MADE A PART OF ANY AGREEMENT BETWEEN US. THIS QUOTATION IS SUBJECT TO IMMEDIATE ACCEPTANCE AND THE PRICE INCLUDES ONLY THE MATERIAL LISTED BELOW.

| ITEM NO | QUANTITY | ARTICLES AND DESCRIPTION | UNIT PRICE | TOTAL AMOUNT |
|---------|----------|---|------------|--------------|
| | 1 | <p>New Boehringer Model RC-14 Portable Concrete and Asphalt Recycling Plant.</p> <p>Boehringer RC-14 Recycle Crusher:</p> <p>This impact crusher is a horizontal shaft, fixed blow bar impactor especially developed for crushing of concrete and asphalt. Aggregate may also be processed.</p> <p>Feed opening: 37" x 57"</p> <p>It consists of a lower housing with AR wear plates. The rotor is of solid construction with high WR², equipped with 4 blow bars made from special steel alloy castings that can be reversed and replaced vertically or horizontally. The rotor locks for safe maintenance. The bearings are mounted on shaft with replaceable adapter sleeves. The upper housing is protected with AR wear plates and designed with the rear part hinged, so it can be fully opened hydraulically. Two (2) impact mechanisms gravity hung with adjusting spindles (rear one adjusted hydraulically). Front apron is of single casting reversible. Rear apron fabricated with bolt-on impact plates.</p> <p>Feed Hood: of 3/4" thick welded steel reinforced construction with chain and rubber curtain. Feed spout lined 1-1/4".</p> <p>Recirculating Product Spout: 33" feed dia. made of 1/4" thick steel plate.</p> | | |

Magness

This Quotation includes Pages:

ABOVE PRICES ARE F.O.B. Clearwater, Florida Area

SHIPMENT Approximately 10 to 12 weeks.

TERMS See Page 10.

Bill Magness

Bill Magness /sw

QUOTATION (cont'd.)

LINDER INDUSTRIAL MACHINERY COMPANY
 1601 S. Frontage Road
 Plant City, Florida 33566

PAGE: 2
 QUOTATION NO: 4005, Rev. #1
 DATE: 1-30-94

| ITEM NO | QUANTITY | ARTICLES AND DESCRIPTION | UNIT PRICE | TOTAL AMOUNT |
|---------|----------|---|------------|--------------|
| | | <p>Discharge Chute: of 3/4" thick welded steel reinforced construction.</p> <p>Electric Motor: 300 HP, 460 volt, 3 Ph., 1750 RPM, Service Factor 1.15, WEG electric motor with thermistors.</p> <p>Crusher Drive: complete with eight (8) 8V-3000 belts, motor pulley, crusher pulley, motor slide rails, base, guard.</p> <p>Feeder: 57" wide x 20' long vibrating grizzly feeder with 14' long solid deck impact section heavily lined complete with 6' long deck grizzly section with adjustable Scandia 400 AR steel bars.</p> <p>Feeder Drive: Feeder is driven by a 60 HP, 460 volt, 3 Ph., 60 Hz., eddy current, TEFC electric motor with controller, fixed motor base, complete with v-belts, motor and feeder sheaves.</p> <p>Feed Hopper: 20 tons capacity receiving hopper constructed of 1" thick steel plate with reinforcing. Hopper folds for height clearance. Hopper and feeder can be removed as a single module when highway restrictions prevail.</p> <p>By-Pass Chute: Collecting hopper with flop gate located under grizzly section to contain material passing through grizzly section. Fabricated from 3/8" steel plate and reinforcing. 1/2" liners in areas of wear.</p> <p>Chassis: Heavy duty 21" deep I-beam trailer frame construction with fishplating in areas of stress. Chassis is complete with access ladder, operator's walkways and platform, handrails, and back plates, king pin.</p> <p>Under Carriage: Reyco triple axle suspension fitted with twelve (12) wheels and 11:00 x 20, 12 ply tires, air brakes, running and braking lights.</p> <p>Blocking Legs: Folding type extending wider than plant for greater stability. Heavy duty with cross bracings. Plant design requires only 10" lift above ground. Four (4) steel blocks removed for transport.</p> <p>Lifting Device: Consisting of five (5) hydraulic jacks mounted on trailer frame to elevate and</p> | | |

variable feed?
yes.

By Pass Carriage?

QUOTATION (cont'd.)

LINDER INDUSTRIAL MACHINERY COMPANY
 1601 S. Frontage Road
 Plant City, Florida 33566

PAGE: 3
 QUOTATION NO: 4005, Rev. #1
 DATE: 1-30-94

| ITEM NO | QUANTITY | ARTICLES AND DESCRIPTION | UNIT PRICE | TOTAL AMOUNT |
|---------|----------|---|------------|--|
| | | level plant. Power unit consists of 35 gallon oil reservoir, pump, 7-1/2 HP motor, solenoid pushbuttons with controls, hoses, etc. | | |
| | | Boehringer design 48" x 6' long vibrating feeder mounted under crusher to transfer crushed material and rebar steel onto a product discharge conveyor. | | |
| 1 | | New Portable Discharge System with Magnetic Separator: Includes belt protecting gathering hopper with replaceable liners, 48" x 40' channel frame type conveyor, 20° troughing idlers, oil resistant belt, 10' of skirtboard with rubber flashing, 71" track rigid axle with two (2) 10:00 x 20, 12 ply tires, lunette eye tongue, heavy gauge tool box, 10 HP, 1800 RPM, TEFC, electric motor drive. | | |
| | | | | <p><i>Steel PAD Feeder</i></p> <p><i>299,775⁰⁰</i></p> <p><i>Superior</i></p> <p><i>31,147⁰⁰</i></p> |
| 1 | | New Dings Model 44CR Continuous Belt Magnet with stainless steel discharge belt, 5 HP, 1800 RPM, TEFC, electric motor drive, and magnet transformer. | | |
| | | | | <i>19,139⁰⁰</i> |
| 1 | | New Superior 36" x 80' Portable Radial Stacking Conveyor. | | |
| | | <ul style="list-style-type: none"> - Main frame 30" deep truss with 3" x 3" x 1/4" chord angles and lattice members of 1-1/2" x 1-1/2" x 3/16" with tapered head and tail sections. - Adjustable height undercarriage, manual raise with pin lock height adjustment. - Telescoping axle with single 10:00 x 20 tires with telescoping axle and swiveling wheels. - 25 HP head end drive Dodge TXT-515 shaft mount reducer, 1800 RPM, TEFC motor, v-belt drive, and drive guard. Drive designed for 600 TPH of 100#/CF of material at 300 FPM belt speed. - Drive pulley 16" dia. crown faced, herringbone lagged magnetic drum with cold rolled shaft. - Tail pulley 14" dia. crown faced, wing type pulley with cold rolled shaft. - Take-Ups screw type with 18" of travel. - Belting 2 ply, 1/8" x 1/16" covers, 220 PIW. - Belt splice Flexco mechanical steel fasteners. - Troughing Idlers - CEMA B, Superior 605 series, 5" dia. rolls, 35° trough, sealed for life ball bearings, placed 16" on center under loading area, 4' on center on balance of conveyor. - Return idlers - CEMA B, Superior 605 series, 5" dia. rolls, sealed for life ball bearings, placed 10' on center. | | |

QUOTATION (cont'd.)

LINDER INDUSTRIAL MACHINERY COMPANY
 1601 S. Frontage Road
 Plant City, Florida 33566

PAGE: 4
 QUOTATION NO: 4005, Rev. #1
 DATE: 1-30-94

| ITEM NO | QUANTITY | ARTICLES AND DESCRIPTION | UNIT PRICE | TOTAL AMOUNT |
|---------|----------|--|--|--------------|
| | | <ul style="list-style-type: none"> - Guarding - Tail pulley shield, v-belt drive guard, pinch points and nip guards on drive pulley. - Paint - Unit to be one (1) coat primer and one (1) coat enamel painted Superior Orange <i>Orange</i>. - Pivot type belt scraper with counterweight tensioning. - Towing eye for field transport. - Anchor pivot plate maintains tail end during radial travel. - Backstop for TXT-515 reducer. - Radial receiving hopper, 5' long with adjustable rubber flashing. - Fifth wheel hitch for road travel. | | |
| 1 | | <p>New Superior 24" x 80' Portable Radial Stacking Conveyor. <i>[Signature]</i></p> <ul style="list-style-type: none"> - Main frame, 24" deep truss with 2-1/2" x 2-1/2" x 1/4" chord angles and lattice members of 1-1/2" x 1-1/2" x 3/16" with tapered head and tail sections and extra chord angle full length from tail end to head end and under-carriage pinning point. - Adjustable height under carriage - manual raise with pin lock height adjustment. - Telescoping axle, with single 10:00 x 20 tires with telescoping axle and swiveling wheels. - 15 HP head end drive, Dodge TXT-415 shaft mount reducer, 1800 RPM, TEFC motor, v-belt drive, and drive guard. Drive designed for 300 TPH of 100#/CF of material at 300 FPM belt speed. - Drive pulley 16" dia. crowned faced, herring-bone lagged drum with cold rolled shaft. - Tail pulley 14" dia. crown faced, wing type pulley with cold rolled shaft. - Take-ups screw type with 18" of travel. - Belting 2 ply, 1/8" x 1/16" covers, 220 PIW. - Belt splice Flexco mechanical steel fasteners. - Troughing idlers - CEMA B, Superior 605 series, 5" dia. rolls, 35° trough, sealed for life ball bearings, placed 16" on center under loading area, 4' on center on balance of conveyor. - Return idlers - CEMA B, Superior 605 series, 5" dia. rolls, sealed for life ball bearings, placed 10' on center. - Guarding - Tail pulley shield, v-belt drive guard, pinch points and nip guards on drive pulley. - Paint - Unit to be one (1) coat primer and one (1) coat finish enamel painted Superior Orange. - Pivot type belt scraper with counterweight tensioning. | <p><i>25,038⁰⁰</i></p> <p><i>Picking Stations</i></p> | |

QUOTATION (cont'd.)

LINDER INDUSTRIAL MACHINERY COMPANY
 1601 S. Frontage Road
 Plant City, Florida 33566

PAGE: 5
 QUOTATION NO: 4005, Rev. #1
 DATE: 1-30-94

| ITEM NO | QUANTITY | ARTICLES AND DESCRIPTION | UNIT PRICE | TOTAL AMOUNT |
|---------|----------|--|----------------------------|--------------|
| | | <ul style="list-style-type: none"> - Towing eye - for field transport. - Anchor pivot plate - maintains tail end during radial travel. - Backstop - for TXT-415 reducer. - Radial receiving hopper, 5' long with adjustable rubber flashing. - Fifth wheel hitch, for road travel. | | |
| | 3 | <p>New Superior 24" x 60' Portable Radial Stacking Conveyors.</p> <ul style="list-style-type: none"> - Main frame, 24" deep truss with 2-1/2" x 2-1/2" x 1/4" chord angles and lattice members of 1-1/2" x 1-1/2" x 3/16" with tapered head and tail sections. - Adjustable height under carriage - manual raise with pin lock height adjustment. - Telescoping axle, with single 10:00 x 20 tires with telescoping axle and swiveling wheels. - 10 HP head end drive, Dodge TXT-315 shaft mount reducer, 1800 RPM, TEFC motor, v-belt drive, and drive guard. Drive designed for 300 TPH of 100#/CF of material at 300 FPM belt speed. - Drive pulley 16" dia. crowned faced, herringbone lagged drum with cold rolled shaft. - Tail pulley 14" dia. crown faced, wing type pulley with cold rolled shaft. - Take-ups screw type with 18" of travel. - Belting 2 ply, 1/8" x 1/16" covers, 220 PIW. - Belt splice Flexco mechanical steel fasteners. - Troughing idlers - CEMA B, Superior 605 series, 5" dia. rolls, 35° trough, sealed for life ball bearings, placed 16" on center under loading area, 4' on center on balance of conveyor. - Return idlers - CEMA B, Superior 605 series, 5" dia. rolls, sealed for life ball bearings, placed 10' on center. - Gathering Hopper, 5' long with adjustable rubber flashing. - Guarding - Tail pulley shield, v-belt drive guard, pinch points and nip guards on drive pulley. - Paint - Unit to be one (1) coat primer and one (1) coat finish enamel painted Superior Orange. - Pivot type belt scraper with counterweight tensioning. - Towing eye - for field transport. - Anchor pivot plate - maintains tail end during radial travel. - Backstop - for TXT-315 reducer. - Radial receiving hopper. - Fifth wheel hitch, for road travel. | <p>21,398⁰⁰</p> | |
| | | | <p>15,858⁰⁰</p> | |

WHITE ROCK QUARRIES - Portable Crushing Unit
Total Emissions Produced by Facility

| Point | Emission Point Name | PM10 lb/hr | PM10 ton/yr | SOx lb/hr | SOx ton/yr | CO lb/hr | CO ton/yr | NOx lb/hr | NOx ton/yr | TOC lb/hr | TOC ton/yr |
|-------|--|---------------|----------------|--------------|---------------|-------------|--------------|--------------|---------------|--------------|---------------|
| 001 | Receiving Hopper / Grizzly Feeder | 0.53 | 0.82 | 0.00 | 0.00 | 0.00 | 0.00 | 0.00 | 0.00 | 0.00 | 0.00 |
| 002 | Crusher Discharge Pan | 0.53 | 0.82 | 0.00 | 0.00 | 0.00 | 0.00 | 0.00 | 0.00 | 0.00 | 0.00 |
| 003 | Drop Point Cruher Belt to Screener Belt | 0.60 | 0.94 | 0.00 | 0.00 | 0.00 | 0.00 | 0.00 | 0.00 | 0.00 | 0.00 |
| 004 | Drop Point Pre-Screener Belt to Vibrating Screening Deck | 1.20 | 1.87 | 0.00 | 0.00 | 0.00 | 0.00 | 0.00 | 0.00 | 0.00 | 0.00 |
| 005 | Drop Point Vibrating Screener to Screened Material Discharge | 1.20 | 1.87 | 0.00 | 0.00 | 0.00 | 0.00 | 0.00 | 0.00 | 0.00 | 0.00 |
| 006 | Drop Point Screened Material Discharge Belt to Radial | 0.53 | 0.82 | 0.00 | 0.00 | 0.00 | 0.00 | 0.00 | 0.00 | 0.00 | 0.00 |
| 007 | Drop Point - Stacker Belt No.1 to Stacker Belt No.2 | 1.20 | 1.87 | 0.00 | 0.00 | 0.00 | 0.00 | 0.00 | 0.00 | 0.00 | 0.00 |
| 008 | Drop Point from Stacker Belt No.1 or No. 2 to Stockpile | 1.20 | 1.87 | 0.00 | 0.00 | 0.00 | 0.00 | 0.00 | 0.00 | 0.00 | 0.00 |
| 009 | Caterpillar Diesel Generator | 1.07 | 1.67 | 1.00 | 1.56 | 3.28 | 5.12 | 15.21 | 23.73 | 1.24 | 1.93 |
| | TOTALS: | 8.06 | 12.55 | 1.00 | 1.56 | 3.28 | 5.12 | 15.21 | 23.73 | 1.24 | 1.93 |