



# Florida Gas Transmission Company

A Southern Union/El Paso Affiliate

5444 Westheimer Road  
Houston, TX 77056-5306

P.O. Box 4967  
Houston, TX 77210-4967  
713.989.7000

November 26, 2008

*UPS Overnight*  
~~CERTIFIED MAIL - RETURN RECEIPT~~

Ms. Trina Vielhauer, Chief  
Bureau of Air Regulation  
Florida Department of Environmental Protection  
2600 Blairstone, MS 5500  
Tallahassee, FL 32399-2400  
Phone: 850-921-9504

Reference: Facility: 0170035  
Compressor Station No. 26, Citrus County

Dear Ms. Vielhauer:

*Project No.: 0170035-02-AC*

RECEIVED

NOV 26 2008

BUREAU OF AIR REGULATION

**Subject: Application for Air Construction Permit**

Florida Gas Transmission Company (FGT) is proposing to install a new 20,500 hp natural gas fired compressor turbine at Compressor Station No. 26 located in Citrus County. The facility is currently a minor source under both New Source Review and Title V definitions, but increases in emissions from the proposed modifications will make the facility a major source under Title V. It will remain a minor source for NSPS purposes. Therefore, a state only construction permit is required. FGT is also installing two new emergency generators at the above referenced facility. An initial Title V Permit application will be submitted independently.

Enclosed is an Application with supporting documentation for an Air Construction Permit for the proposed modifications. A processing fee of \$2250.00 is attached.

If you have any questions or need additional information, please call me at (713) 989-7459.

Sincerely,

Charles Wait  
Principal Engineer

CC: Arnold L. Eisenstein  
Frank Diemont  
Kevin McGlynn, P.E.  
Duane Pierce, AQMcS, LLC  
Compressor Station No. 26



# **Application for Air Permit to Construct**

**Florida Gas Transmission Company, LLC  
Phase VIII Expansion Project  
Quincy Compressor Station No. 26  
Lecanto, Citrus County, Florida  
Facility No. 0170035**

**November 2008**

## Table of Contents

|       |  |    |
|-------|--|----|
| 1.0   | INTRODUCTION .....   | 1  |
| 2.0   | PROJECT DESCRIPTION .....  | 3  |
| 2.1   | <i>Existing Operations</i> .....   | 3  |
| 2.2   | <i>Proposed Modifications</i> .....  | 3  |
| 2.2.1 | <i>New Compressor Turbine</i> .....  | 4  |
| 2.2.2 | <i>New Emergency Generators</i> .....  | 7  |
| 2.2.3 | <i>Support Equipment</i> .....   | 7  |
| 2.2.4 | <i>New Storage Tanks</i> .....   | 7  |
| 2.2.5 | <i>Fugitive Emissions</i> .....  | 7  |
| 2.2   | <i>Emissions Summary</i> .....   | 11 |
| 3.0   | REGULATORY ANALYSIS .....  | 13 |
| 3.2   | <i>Federal Regulations Review</i> .....  | 13 |
| 3.1.1 | <i>Classification of Ambient Air Quality</i> .....   | 13 |
| 3.1.2 | <i>PSD Applicability</i> .....   | 14 |
| 3.1.3 | <i>Non-attainment New Source Review (NNSR) Applicability</i> .....                               | 16 |
| 3.1.4 | <i>Applicability of New Source Performance Standards (NSPS)</i> .....                            | 16 |
| 3.1.5 | <i>Applicability of National Emission Standards for Hazardous Air Pollutants (NESHAPS)</i> ..... | 18 |
| 3.1.6 | <i>Applicability of Title V</i> .....  | 18 |
| 3.2   | <i>Florida State Air Quality Regulations</i> .....   | 19 |
| 3.2.1 | <i>Rule 62-210.300 Permits Required</i> .....  | 19 |
| 3.2.2 | <i>Rule 62-204.240 Ambient Air Quality Standards</i> .....                                       | 19 |
| 3.2.3 | <i>Rule 62-296.320(2) Objectionable Odors</i> .....  | 19 |
| 3.2.4 | <i>Rule 62-296.320(4)(b)1 General Particulate Emission Limiting Standards</i> .....              | 19 |
| 4.0   | REFERENCES .....   | 20 |

|              |   |
|--------------|---|
| Attachment A | DEP Forms   |
| Attachment B | Process Flow Diagram  |
| Attachment C | Precautions to Prevent Emissions of Unconfined Particulate Matter |
| Attachment D | Plot Plan   |
| Attachment E | Vendor Information  |
| Attachment F | Calculations  |
| Attachment G | Fuel Analysis   |
| Attachment H | Exempt Sources List   |

**List of Tables**

**Table 2-1 Summary of Existing Compressor Engines .....4**  
**Table 2-2 Proposed New Turbine (2603) Specifications and Stack Parameters .....5**  
**Table 2-3 Proposed New Turbine (2603) Compressor Engine Emissions .....6**  
**Table 2-4 Proposed Emergency Generator Engines Specifications and Stack Parameters .....8**  
**Table 2-5 Emissions from Each Proposed Generator Engine .....9**  
**Table 2-6 New Storage Tanks for Compressor Station No. 26.....10**  
**Table 2-7 VOC Fugitive Emission Calculations and Summary .....11**  
**Table 2-8 Potential Annual Emissions (tpy) Summary .....12**  
**Table 3-1 National and State Ambient Air Quality Standards ( $\mu\text{g}/\text{m}^3$ ) .....14**  
**Table 3-2 Applicability of PSD Significant Emission Rates .....15**  
**Table 3-3 Applicability of New Source Performance Standards Subpart KKKK .....17**  
**Table 3-4 Applicability of New Source Performance Standards Subpart JJJJ .....18**

**List of Figures**

**Figure 1-1 Location Map.....2**

## 1.0 INTRODUCTION

Florida Gas Transmission Company (FGT) is proposing to expand its existing natural gas pipeline facility near Lecanto, in Citrus County, Florida (Compressor Station No. 26). This proposed modification is part of FGT's Phase VIII Expansion Project, aimed at increasing the supply capacity of FGT's network servicing domestic suppliers, commercial, and industrial customers in Florida. The scope of work for the Phase VIII Expansion Project includes expansion through the addition of state-of-the-art compressor engines at nine existing compressor stations within the States of Florida and Alabama. Three compressor stations within Florida will receive electric driven turbine compressors and five compressor stations within Florida will receive natural gas-fired turbine compressors.

Compressor Station No. 26 is located in Citrus County, Florida, northwest of the town of Lecanto on North Maylen Road 0.4 miles north of Highway 44. Figure 1-1 shows the location of the existing compressor station.

The proposed expansion consists of the installation of a 20,500 bhp natural gas-fired turbine. The turbine will be a Solar Titan 130-20502S unit and will be used solely for transporting natural gas by pipeline for distribution to markets in Florida.

Additionally, FGT is also proposing to add two new emergency generators at this facility. Each of the two new generators will be powered by a 454 bhp, gas-fired reciprocating compressor engine which will meet the new 40 CFR Subpart JJJJ standards.

Based on projected new annual emission rates, the proposed modifications would result in a NO<sub>x</sub> potential emission increase of 37.5 tpy and a CO potential emission increase of 38.3 tpy; therefore, this modification will not constitute a significant modification at an existing major stationary source under Prevention of Significant Deterioration (PSD) regulations. Since there will be no PSD significant increase in the emissions of any contaminant, a state only construction permit is required.

This narrative contains three additional sections. Descriptions of the existing operation at FGT's Compressor Station No. 26, the proposed new engine and new emergency generators are presented in Section 2.0. The air quality review requirements and applicability of state and federal regulations are discussed in Section 3.0. References are included in Section 4.0. FDEP permit application forms are provided in Attachment A. Attachment B contains a process flow diagram, Attachment C contains Precautions to Prevent Emissions of Unconfined Particulate Matter, Attachment D contains a plot plan of the facility and Attachment E provides vendor information. Attachment F provides emission calculations, Attachment G a recent fuel analysis and Attachment H a list of exempt sources.

Figure 1-1 Location Map

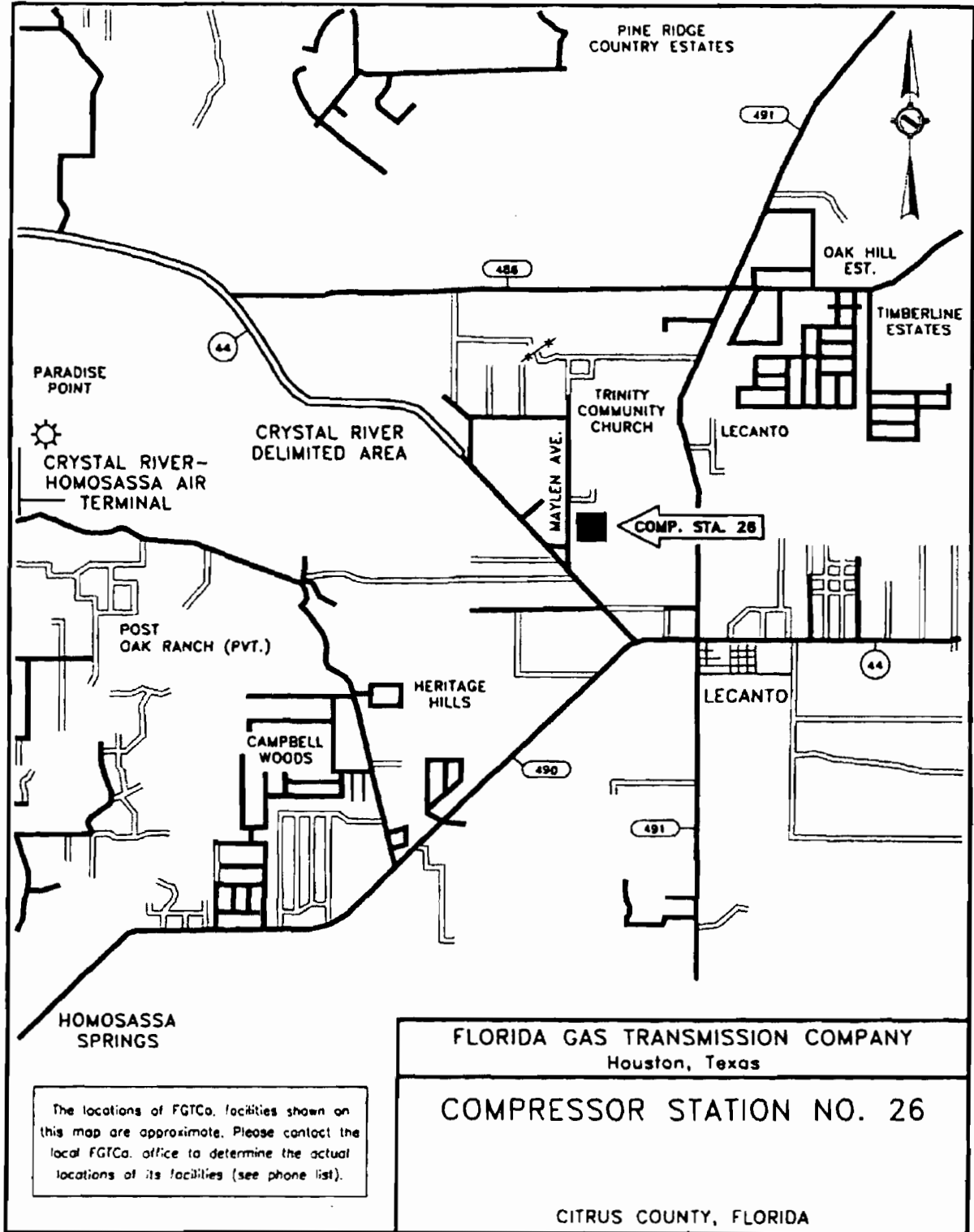

## **2.0 PROJECT DESCRIPTION**

A plot plan of FGT's Compressor Station No. 26, showing the location of the plant boundaries, and the location of the new turbine and generators is presented in Attachment B. The following sections provide a description of the existing operations at this location, as well as a description of the proposed project.

### **2.1 Existing Operations**

FGT's existing Compressor Station No. 26 consists of one 7,000 bhp (ISO) natural gas-fired turbine. Table 2-1 summarizes engine manufacturer, model, and the date of installation for each of the existing engines. Compressor Engine 2601 was initially installed in 1993 at 6500 bhp. There was a Compressor Engine 2602 that was initially installed in 2001, but has been replaced by an electric drive unit.

The existing facility also has supporting equipment including lube and used oil storage tanks, air compressors and emergency generators.

### **2.2 Proposed Modifications**

FGT proposes to increase the horsepower capacity of Compressor Station No. 26, as part of the Phase VIII Expansion Project. This will involve adding a new gas-fired turbine (Compressor Engine 2603). The new engine will be used to increase the volumetric delivery capacity by driving a gas compressor that is a part of a gas transmission line that transports natural gas from source wells in Texas and Louisiana for delivery throughout Florida. Without the proposed modifications, it would not be possible to increase the volumetric delivery capacity necessary to meet both short and long-term demands for natural gas in Florida.

In addition, as part of the project, two new emergency generators will be installed. Each will be powered by a 454 bhp, gas-fired, 4-stroke, rich burn reciprocating compressor engine equipped with emissions that will be controlled to meet the new 40 CFR Subpart JJJJ standards as required. Details of the changes are described in the following sections.



**Table 2-1 Summary of Existing Compressor Engines**

| <b>Engine #</b> | <b>Date of Installation</b> | <b>Type</b> | <b>Manufacturer</b> | <b>Model #</b>    | <b>Brake Horse Power (bhp)</b> |
|-----------------|-----------------------------|-------------|---------------------|-------------------|--------------------------------|
| 2601            | 1993                        | Turbine     | Solar               | Taurus 60 T-7300S | 7,000                          |

**2.2.1 New Compressor Turbine**

FGT proposes to install one new natural gas-fired turbine engine compressor unit at Compressor Station No. 26. The engine is a Solar Titan 130 - 20502S turbine compressor unit rated at 20,500 bhp (ISO). Fuel will be exclusively natural gas from FGT's natural gas pipeline. Engine specifications and stack parameters for the proposed engine are presented in Table 2-2.

**Table 2-2 Proposed New Turbine (2603) Specifications and Stack Parameters**

| <b>Parameter</b>   | <b>Design</b>                |
|--|------------------------------|
| Compressor Engine  | 2603                         |
| Type   | Gas Turbine                  |
| Manufacturer   | Solar                        |
| Model  | Titan 130 20502S             |
| Unit Size (shaft)  | 19,465 bhp (ISO)             |
| Specific Heat Input (LHV) <sup>a</sup>   | 7,326 Btu/hp-hr              |
| Specific Heat Input (HHV) <sup>b</sup>   | 8,112 Btu/hp-hr              |
| Fuel Flow (LHV) <sup>a</sup>   | 142.59 MM Btu/hr             |
| Fuel Flow (HHV) <sup>a</sup>   | 157.89 MM Btu/hr             |
| Maximum Fuel Consumption <sup>c</sup>  | 0.1518 MMscf/hr              |
| Speed  | 8,351 rpm                    |
| Stack Parameters   |                              |
| Stack Height   | 55 ft                        |
| Stack Diameter   | 7.5 ft x 8 ft (rectangular)  |
| Exhaust Gas Flow   | 393,142 lb/h<br>232,782 acfm |
| Exhaust Temperature  | 944 °F                       |
| Exhaust Gas Velocity   | 64.7 ft/sec                  |
| <p><b>NOTE:</b></p> <p>acfm = actual cubic feet per minute.</p> <p>bhp = brake horsepower.</p> <p>Btu/hp-hr = British thermal units per brake horsepower per hour.</p> <p>°F = degrees Fahrenheit.</p> <p>ft = feet.</p> <p>ft/sec = feet per second.</p> <p>MMscf/hr = million standard cubic feet per hour.</p> <p>rpm = revolutions per minute.</p> <p><sup>a</sup> Based on vendor provided lower heat rate value (LHV) of 7,326 Btu/hp-hr, a lower heating value of 939.2 Btu/scf and</p> <p><sup>b</sup> Based on natural gas with a HHV of 1040 British thermal units per standard cubic foot (Btu/scf).</p> <p><sup>c</sup> While producing 19,465 bhp at ISO conditions and with gas having HHV of 1040 Btu/scf</p> |                              |

Hourly and annual emissions of regulated pollutants from the proposed new turbine at ISO conditions are presented in Table 2-3. Emissions of oxides of nitrogen (NO<sub>x</sub>), carbon monoxide (CO) and non-methane hydrocarbons (NMHC) or volatile organic compounds (VOC) are based on the engine manufacturer's supplied data (See Attachment C). These values are based on ISO conditions. Other factors such as inlet, outlet losses and ambient temperature can affect these rates.

Typically, turbine vendors do not provide information on particulate matter (PM), sulfur dioxide (SO<sub>2</sub>) or hazardous air pollutant (HAP) emissions; therefore, PM and HAP emissions are based

upon USEPA publication AP-42 Section 3.1 (USEPA, 2000). Emissions of SO<sub>2</sub> are based on FGT's Federal Energy Regulatory Commission (FERC) certificate limit of 10 grains sulfur per 100 cubic feet of natural gas.

**Table 2-3 Proposed New Turbine (2603) Compressor Engine Emissions**

| Pollutant                                    | Emission Factor      | Reference           | lb/hr | TPY   |
|--|----------------------|---------------------|-------|-------|
| Nitrogen Oxides <sup>a</sup>                 | 8.52 lb/hr           | Manufacturer Data   | 8.52  | 37.31 |
| Carbon Monoxide <sup>a</sup>                 | 8.64 lb/hr           | Manufacturer Data   | 8.64  | 37.86 |
| Volatile Organic <sup>a,b</sup><br>Compounds | 0.50 lb/hr           | Manufacturer Data   | 0.50  | 2.17  |
| Particulate Matter <sup>c</sup>              | 0.0066 lb/MMBtu      | AP-42, Table 3.1-2a | 1.04  | 4.56  |
| Sulfur Dioxide <sup>c</sup>                  | 10 grains/100 scf    | FERC Limit          | 4.34  | 19.00 |
| HAPS <sup>c</sup>                            | 0.001027<br>lb/MMBtu | AP-42, Table 3.1-2a | 0.16  | 0.71  |

<sup>a</sup> Emissions based on vendor provided values at ISO conditions and inlet and exhaust losses at 4" of H<sub>2</sub>O.

<sup>b</sup> Assumes that VOCs are 10% of THC

<sup>c</sup> Emissions based on vendor provided heat rate at higher heating value.

### **2.2.2 New emergency Generators**

The new generators will be powered by natural gas fueled, rich burn Generac Model SG300 rated at 300 kW (454 bhp). Engine specifications and stack parameters for the proposed engines are presented in Table 2-4 and emissions are presented in Table 2-5.

### **2.2.3 Support Equipment**

In addition to the compressor engine, some support equipment will be installed at the site. They include:

- One compressor building
- An auxiliary building
- A control building

The locations of the structures are shown on the facility plot plan contained in Attachment D. The compressor buildings, each housing a new turbine, have approximate dimensions of 52 feet wide by 80 feet long by 26 feet high. The approximate dimensions of the auxiliary building will be 32 feet wide by 48 feet long by 14 feet high and the approximate dimensions of the control building will be 14 feet wide by 55 feet long by 12 feet high.

### **2.2.4 New Storage Tanks**

Three new storage tanks will be installed at Compressor Station No. 26. The tanks are a 500 gallon oily water storage tank, a 100 barrel condensate storage tank and a 5000 gallon pressurized odorant tank. Specifications for these tanks are listed in Table 2-5. Emissions were calculated with the U.S EPA's (USEPA) Tank 4.0 D. Details of the calculations can be found in Attachment F. These emission units are exempt under Rule 62-210.300(3)(b), F.A.C.

### **2.2.5 Fugitive Emissions**

Potential new emissions from Compressor Station No. 26 also include fugitive emissions from the new valves and flanges that will be in gas service. These fugitive emissions have been estimated using USEPA factors for components in gas service at oil and gas facilities (EPA publication EPA-453/R-95-017, November 1995, "Protocol for Equipment Leak Emission Estimates"). Table 2-7 lists the quantities new components to be added as part of the Phase VIII Expansion Project and an estimate of the fugitive emissions from these sources.

**Table 2-4 Proposed Emergency Generator Engines Specifications and Stack Parameters**

| Parameter   | Design                               |
|---|--------------------------------------|
| Compressor Engine   | Gen03/Gen04                          |
| Type  | Natural Gas, Rich Burn Reciprocating |
| Manufacturer  | Generac                              |
| Model   | SG300                                |
| Unit Size   | 454 bhp                              |
| Heat Input  | 4.26 MM Btu/hr                       |
| Fuel Consumption <sup>a</sup>   | 0.00410 MMscf/h                      |
| Speed   | 2300 rpm                             |
| Stack Parameters  |                                      |
| Stack Height  | 20 ft                                |
| Stack Diameter  | 0.67 ft                              |
| Exhaust Gas Flow  | 5,300 lb/hr                          |
| Exhaust Gas Flow  | 2,911 acfm                           |
| Exhaust Temperature   | 1490 °F                              |
| Exhaust Gas Velocity  | 138.85 ft/sec                        |
| <p><b>NOTE:</b></p> <p>acfm = actual cubic feet per minute.<br/> bhp = brake horsepower.<br/> Btu/hr = British thermal units per hour.<br/> °F = degrees Fahrenheit.<br/> ft = feet.<br/> ft/sec = feet per second.<br/> Lb/hr = pound per hour.<br/> rpm = revolutions per minute.<br/> scf/h = standard cubic feet per hour</p> <p><sup>a</sup> Based on heating value for natural gas of 1040 British thermal units per standard cubic foot (Btu/scf).</p> |                                      |

**Table 2-5 Emissions from Each Proposed Generator Engine**

| Pollutant                               | Uncontrolled      |                    |                     | Controlled        |                    |                     | Reference          |
|---|-------------------|--------------------|---------------------|-------------------|--------------------|---------------------|--------------------|
|   | Emission Factor   | lb/hr <sup>a</sup> | TPY <sup>a, b</sup> | Emission Factor   | lb/hr <sup>a</sup> | TPY <sup>a, b</sup> |                    |
| Nitrogen Oxides                         | 2.12 g/hp-hr      | 2.12               | 0.11                | 2.0 g/hp-hr       | 2.00               | 0.109               | NSPS               |
| Carbon Monoxide                         | 118.3 g/hp-hr     | 118.41             | 5.92                | 4.0 g/hp-hr       | 4.03               | 0.20                | NSPS               |
| Volatile Organic Compounds <sup>c</sup> | 0.29 g/hp-hr      | 0.29               | 0.01                | 0.29 g/hp-hr      | 0.29               | 0.01                | NSPS               |
| Particulate Matter                      | 0.01941 lb/MMBtu  | 0.083              | <0.01               | 0.01941 lb/MMBtu  | 0.083              | <0.01               | AP-42, Table 3.2-3 |
| Sulfur Dioxide                          | 10 grains/100 scf | 0.117              | 0.01                | 10 grains/100 scf | 0.117              | 0.01                | FERC Limit         |
| Hazardous Air Pollutants                | 0.0234 lb/MMBtu   | 0.10               | 0.01                | 0.0234 lb/MMBtu   | 0.10               | 0.01                | AP-42, Table 3.2-3 |

- a. The manufacturer has not finalized design at this time. Actual values may be lower.
- b. Based on 454 bhp, 100 hours of operation per year
- c. assumed VOC 10% of UHC/THC

**Table 2-6 New Storage Tanks for Compressor Station No. 26**

| <b>Tank Name</b>                 | <b>Condensate Tank</b> | <b>Oily Water Tank</b>                | <b>Odorant Tank</b> |
|----------------------------------|------------------------|---------------------------------------|---------------------|
| <b>Type of Tank</b>              | Vertical, Cone Roof    | Vertical, Cone Roof                   | Horizontal          |
| <b>Contents</b>                  | Hydrocarbon Liquids    | Drain water from washings; oily water | Odorant             |
| <b>Dimensions</b>                | 8' dia x 12' high      | 4' dia x 6' high                      | 10' dia x 12' long  |
| <b>Capacity</b>                  | 100 Barrels            | 500 Gallons                           | 5000 Gallons        |
| <b>Paint Color</b>               | White                  | White                                 | White               |
| <b>Maximum Annual Throughput</b> | 500 Gallons            | 500 Gallons                           | 5000 Gallons        |
| <b>Pressurized</b>               | No                     | No                                    | Yes                 |
| <b>VOC Emissions (tpy)</b>       | 0.01                   | <0.001                                | 0.00                |

**Table 2-7 VOC Fugitive Emission Calculations and Summary**

**New Components**

| <b>Component</b> | <b>Service</b> | <b>Component<br/>Count</b> | <b>Emissions *<br/>Factor<br/>(ton/yr)</b> | <b>NM/NE<br/>Fraction</b> | <b>Emissions<br/>(ton/yr)</b> |
|------------------|----------------|----------------------------|--|---------------------------|-------------------------------|
| Valves           | Gas            | 74                         | 0.0434606                                  | 0.05                      | 0.1608                        |
| Connector        | Gas            | 0                          | 0.0019316                                  | 0.05                      | 0.0000                        |
| Flanges          | Gas            | 180                        | 0.0037666                                  | 0.05                      | 0.0339                        |
| Open-Ended Line  | Gas            | 0                          | 0.0193158                                  | 0.05                      | 0.0000                        |
| Pumps            | Gas            | 0                          | 0.023179                                   | 0.05                      | 0.0000                        |
| Other            | Gas            | 0                          | 0.0849895                                  | 0.05                      | 0.0000                        |
| Valves           | Light Oil      | 0                          | 0.0241448                                  | 1.00                      | 0.0000                        |
| Connector        | Light Oil      | 0                          | 0.0020282                                  | 1.00                      | 0.0000                        |
| Flanges          | Light Oil      | 0                          | 0.0010624                                  | 1.00                      | 0.0000                        |
| Open-Ended Line  | Light Oil      | 0                          | 0.0135211                                  | 1.00                      | 0.0000                        |
| Pumps            | Light Oil      | 0                          | 0.1255527                                  | 1.00                      | 0.0000                        |
| Other            | Light Oil      | 0                          | 0.0724343                                  | 1.00                      | 0.0000                        |
| Valves           | Heavy Oil      | 0                          | 0.0000811                                  | 1.00                      | 0.0000                        |
| Connector        | Heavy Oil      | 0                          | 0.0000724                                  | 1.00                      | 0.0000                        |
| Flanges          | Heavy Oil      | 0                          | 0.0000038                                  | 1.00                      | 0.0000                        |
| Open-Ended Line  | Heavy Oil      | 0                          | 0.0013521                                  | 1.00                      | 0.0000                        |
| Other            | Heavy Oil      | 0                          | 0.0002994                                  | 1.00                      | 0.0000                        |
|                  |                |                            |  | <b>TOTAL:</b>             | <b>0.1947</b>                 |

\* \*\*EPA publication EPA-453/R-95-017, November 1995, "Protocol for Equipment Leak Emission Estimates

**2.2 Emissions Summary**

The total changes in emissions resulting from the project are listed on Table 2-8. The calculations used to estimate these emissions are presented in Attachment D.



**Table 2-8 Potential Annual Emissions (tpy) Summary**

| SOURCE ID                                | DESCRIPTION                        | NO <sub>x</sub> | CO          | VOC <sup>a</sup> | SO <sub>2</sub> | PM       | HAPs       |
|--|------------------------------------|-----------------|-------------|------------------|-----------------|----------|------------|
| <b>EXISTING FACILITY</b>                 |                                    |                 |             |                  |                 |          |            |
| 2601                                     | 7,000 bhp Turbine Engine           | 24.5            | 29.8        | 0.9              | 7.5             | 1.8      | 0.3        |
| GEN02                                    | 587 bhp Recip. Engine <sup>b</sup> | 2.2             | 0.6         | 0.01             | 0.15            | 0.2      | 0.0        |
|  | Other Sources: <sup>c</sup>        | 0.0             | 0.0         | 0.3              | 0.0             | 0.0      | 0.0        |
| <b>EXISTING ANNUAL POTENTIAL TOTALS:</b> |                                    | <b>26.7</b>     | <b>30.4</b> | <b>1.2</b>       | <b>7.7</b>      | <b>2</b> | <b>0.3</b> |

| <b>PROPOSED MODIFIED FACILITY</b>        |  |             |             |            |             |            |            |
|--|--|-------------|-------------|------------|-------------|------------|------------|
| 2601                                     | 7,000 bhp Turbine Engine                 | 24.5        | 29.8        | 0.9        | 7.5         | 1.8        | 1.8        |
| 2603                                     | 20,500 hp Turbine Engine – New           | 37.3        | 37.8        | 2.2        | 19.0        | 4.6        | 0.7        |
| GEN02                                    | 443 bhp Recip. Engine <sup>b</sup>       | 2.2         | 0.6         | 0.0        | 0.2         | 0.2        | 0.0        |
| GEN03                                    | 454 bhp Recip. Engine – New <sup>d</sup> | 0.1         | 0.2         | 0.0        | 0.0         | 0.0        | 0.0        |
| GEN04                                    | 454 bhp Recip. Engine – New <sup>d</sup> | 0.1         | 0.2         | 0.0        | 0.0         | 0.0        | 0.0        |
|  | Other Sources: <sup>c</sup>              | 0.0         | 0.0         | 0.5        | 0.0         | 0.0        | 0.0        |
| <b>PROPOSED ANNUAL POTENTIAL TOTALS:</b> |  | <b>64.2</b> | <b>68.7</b> | <b>3.6</b> | <b>26.7</b> | <b>6.6</b> | <b>2.5</b> |

|  |  |             |             |            |           |            |            |
|--|--|-------------|-------------|------------|-----------|------------|------------|
| <b>NET CHANGES IN POTENTIAL EMISSIONS:</b> |  | <b>37.5</b> | <b>38.3</b> | <b>2.4</b> | <b>19</b> | <b>4.6</b> | <b>2.2</b> |
|--|--|-------------|-------------|------------|-----------|------------|------------|

a VOC = Non-methane/non-ethane HC  
 b Based on 500 hr/yr  
 c Other Sources Includes ancillary equipment, storage tanks and equipment leaks  
 d Based on 100 hr/yr

## **3.0 REGULATORY ANALYSIS**

This section presents a review of federal and Florida State air quality regulations, which govern the operations and proposed modifications to be conducted at Compressor Station No. 26.

### **3.2 Federal Regulations Review**

The federal regulatory programs administered by the USEPA have been developed under the authority of the Clean Air Act. The following subsections review the essential elements of the federal regulatory program and the impact they have on the operations and proposed modifications at Compressor Station No. 26.

#### **3.1.1 Classification of Ambient Air quality**

The 1970 Amendments to the CAA gave the USEPA specific authority to establish the minimum level of air quality that all states would be required to achieve. These minimum values or standards were developed in order to protect the public health (primary) and welfare (secondary). The federally promulgated standards and additional state standards are presented on Table 3-1.

Areas of the country that have air quality equal to or better than these standards (i.e., ambient concentrations less than a standard) are designated as "Attainment Areas", while those where monitoring indicates air quality is worse than the standards are known as "Non-attainment Areas." The designation of an area has particular importance for a proposed project as it determines the type of permit review to which the application will be subject.

Major new sources or major modifications to existing major sources located in attainment areas are required to obtain a PSD permit before initiation of construction. Similar sources located in areas designated as non-attainment or that adversely impact such areas undergo more stringent Non-attainment New Source Review (NNSR). In either case, it is necessary, as a first step, to determine the air quality classification of a project site.

All areas of all states are classified as either attainment, non-attainment or unclassifiable for each criteria pollutant. Citrus County is designated as unclassifiable or attainment for all criteria pollutants. These designations were obtained from 40 CFR 81.310, and 62-204.340 F.A.C.

**Table 3-1 National and State Ambient Air Quality Standards ( $\mu\text{g}/\text{m}^3$ )**

| POLLUTANT        | AVERAGING PERIOD     | EPA STANDARDS |           | FLORIDA STANDARDS |
|------------------|----------------------|---------------|-----------|-------------------|
|                  |                      | PRIMARY       | SECONDARY |                   |
| PM <sub>10</sub> | 24-hour <sup>1</sup> | 150           | 150       | 150               |
|                  | Annual <sup>2</sup>  | 50            | 50        | 50                |
| SO <sub>2</sub>  | 3-hour <sup>1</sup>  | ---           | 1,300     | 1,300             |
|                  | 24-hour <sup>1</sup> | 365           | ---       | 260               |
|                  | Annual <sup>2</sup>  | 80            | ---       | 60                |
| CO               | 1-hour <sup>1</sup>  | ---           | 40,000    | 40,000            |
|                  | 8-hour <sup>1</sup>  | 10,000        | ---       | 10,000            |
| NO <sub>2</sub>  | Annual <sup>2</sup>  | 100           | 100       | 100               |
| O <sub>3</sub>   | 1-hour <sup>3</sup>  | 235           | 235       | 235               |

1. Not to be exceeded more than once per year.  
 2. Never to be exceeded.  
 3. Not to be exceeded on more than 3 days over 3 years.

Sources: 40 CFR 50; 36FR22384; Chap. 17-2.300.

The designation of Unclassifiable indicates that there is insufficient monitoring data to prove that the area has attained the federal standards; however, the limited data available indicate that the standard has been achieved. Areas with this classification are treated as attainment areas for permitting purposes. Since Citrus County is considered in attainment for all pollutants, the proposed new emissions are potentially subject to PSD review and not non-attainment review.

### 3.1.2 PSD Applicability

The 1977 CAA Amendments added Part C: Prevention of Significant Deterioration to the Act. This part required proposed new major stationary sources or existing sources planning a major modification in an area that has attained the National AAQS, to conduct a preconstruction review that includes a detailed analysis of the impacts from the source's emissions.

Federal air quality permitting regulations for attainment areas are codified in the Code of Federal Regulations (CFR), Title 40- Protection of the Environment, Part 52.21 - Prevention of Significant Deterioration (40 CFR 52.21). Major revisions to the rules were finalized on December 31, 2002, and became effective on March 3, 2003. State of Florida requirements are located at 62-212.400 F.A.C.

For the PSD regulations to apply to a given project, the project's potential to emit must constitute a new major stationary source or a major modification to an existing major stationary source. A major stationary source is defined as any of the 28 sources identified in 40 CFR 52.21 that has a potential to emit 100 tons or more per year of any regulated pollutant, or any other stationary source that has the potential to emit 250 tons or more per year of a regulated pollutant. "Potential to emit" is determined on an annual basis after the application of air pollution control equipment, or any other federally enforceable restriction.

"Significant" emission rates are defined as amounts equal to or greater than the emission rates given in Table 3-2.

**Table 3-2 Applicability of PSD Significant Emission Rates**

| Pollutant   | Emission Rate<br>Tons/Year |
|---|----------------------------|
| Carbon Monoxide   | 100                        |
| Nitrogen Oxides   | 40                         |
| Sulfur Dioxide  | 40                         |
| Particulate Matter (PM/PM <sub>10</sub> )   | 25/15                      |
| Ozone (VOC)   | 40                         |
| Lead  | 0.6                        |
| Fluorides   | 3                          |
| Reduced Sulfur including Hydrogen Sulfide   | 10                         |
| Total Reduced Sulfur including Hydrogen Sulfide   | 10                         |
| Sulfuric Acid Mist  | 7                          |
| Lead  | 0.6                        |
| Mercury   | 0.1                        |
| VOC = Volatile Organic Compounds<br>Sources: 40 CFR 52.21(b)(23); Table 212.400-2 62-212 F.A.C. |                            |

Proposed project increases for modified sources are determined for each pollutant and are equal to the actual emissions (average of the actual emissions over any 24 month of the ten years immediately prior to the proposed project) subtracted from the proposed future actual emissions. For new sources the emission increase is equal to the potential to emit (PTE) of the source. Fugitive emissions are only included in the potential to emit if the source is one of the 28 named source categories in 40 CFR 52.21(b)(1) or belongs to a stationary source category that is subject to an NSPS proposed prior to August 7, 1980 or that is subject to an NESHAPS promulgated prior to August 7, 1980.

Netting is only required for each regulated pollutant for which the proposed project increases

(decreases are not considered yet) result in a significant increase in emissions. Netting is performed by identifying both the creditable and contemporaneous increases and the reductions in emissions. The contemporaneous period is defined as the period of time from five years prior to the estimated start of construction through estimated start of operation. Since this project does not result in a significant increase, netting is not required.

To summarize, since Compressor Station No. 26 is not one of the 28 named source categories, and emits <250 TPY of each regulated pollutant and the proposed new emissions are not major in themselves, it is not considered a major source or major new source; therefore, the compressor station is not subject to PSD pre-construction review.

### **3.1.3 Non-attainment New Source Review (NNSR) Applicability**

Based on the current non-attainment provisions, all new major stationary sources, or major modifications to such sources, located in a non-attainment area must undergo non-attainment New Source Review, if they have the potential to emit above an NSR significant threshold. For major new sources or major modifications in an attainment or unclassifiable area, the non-attainment provisions apply if the source or modification is located within the area of influence of a non-attainment area. The area of influence is defined as an area, which is outside the boundary of a non-attainment area, but within the locus of all points that are 50 kilometers outside the non-attainment area.

Compressor Station No. 26 is located in an area that is designated as either attainment or not classifiable for all criteria pollutants and is not located in an area of influence outside a non-attainment area. Additionally, Compressor Station No. 26 is not a major source; therefore, this compressor station is not subject to federal non-attainment New Source Review.

### **3.1.4 Applicability of New source Performance Standards (NSPS)**

Standards of Performance for New Sources are published in 40 CFR 60. All Standards apply to all new sources within a given category, regardless of geographic location or ambient air quality at the location.

#### 40 CFR 60 Subpart KKKK

The new turbine to be installed at Compressor Station No. 26 is subject to Subpart KKKK (40 CFR 60.4300), Standards of Performance for Stationary Combustion Turbines, because it will have a maximum heat input at peak load of >10.7 gigajoules/hour (10 MMBtu/hr) based on the higher heating value of the natural gas fuel and because construction will commence after 18

February 2005. This regulation establishes emission limits for NO<sub>x</sub> and SO<sub>2</sub> and requires performance testing and monitoring of fuel sulfur.

The NO<sub>x</sub> emission limit for Subpart KKKK is based on Table 1 of 40 CFR 60 Subpart KKKK. The limit for new turbines firing natural gas and with a heat input at peak load greater than 50 MMBtu/h but not more than 850 MMBtu/h is 25 ppm at 15% O<sub>2</sub>. SO<sub>2</sub> emissions are limited to 0.060 lb SO<sub>2</sub>/MMBtu heat input. For this turbine the limit will be 9.11 lb/hr.

Table 3-3 summarizes the NSPS applicability for the proposed gas engines. FGT will also be required to comply with all recordkeeping and monitoring requirements of this regulation.

The turbine will meet the NSPS for NO<sub>x</sub> of 25 ppmv (i.e., manufacturer's estimation of 15 ppmv), and for SO<sub>2</sub> of 9.11 lb/hr (estimated for this turbine to be 4.17 lb/hr).

40 CFR 60 Subpart JJJJ

The new emergency generator engines are subject to 40 CFR Subpart 60 Subpart JJJJ Standards of Performance for Stationary Spark Ignition Internal Combustion Engines. Owners and operators of stationary spark ignition internal combustion engines with maximum engine power greater than or equal to 100 hp must comply with the standards for NOX, CO and VOC established in Table 1 of Subpart JJJJ. The proposed generator engines will comply with the applicable standards. FGT will also be required to comply with all recordkeeping and monitoring requirements of this regulation.

Table 3-4 summarizes the NSPS applicability for the proposed gas-fired emergency generator engines.

**Table 3-3 Applicability of New Source Performance Standards Subpart KKKK**

| NSPS Regulations | Fuel | Pollutant       | Heat Input Applicability | Equipment Design Maximum | NSPS Emission Limits | Equipment Emissions |
|------------------|------|-----------------|--------------------------|--------------------------|----------------------|---------------------|
| 60.4320(a)       | Gas  | NO <sub>x</sub> | >50 MM Btu/hr            | 158 MM Btu/hr            | 25 ppm <sub>v</sub>  | 15 ppm <sub>v</sub> |
| 60.4330(a)(2)    | Gas  | SO <sub>2</sub> | >50 MM Btu/hr            | 158 MM Btu/hr            | 9.48 lb/hr           | 4.34 lb/hr          |

**Table 3-4 Applicability of New Source Performance Standards Subpart JJJJ**

| <b>NESHAP Regulations</b> | <b>Fuel</b> | <b>Pollutant</b> | <b>Equipment Design Maximum</b> | <b>NSPS Emission Limits (g/hp-hr)</b> | <b>Equipment Emissions (G/hp-hr)</b> |
|---------------------------|-------------|------------------|---------------------------------|---------------------------------------|--------------------------------------|
| 60.4230 Table 1           | Gas         | NO <sub>2</sub>  | 100 hp and higher               | 2.0                                   | 2.00                                 |
| 60.4230 Table 1           | Gas         | CO               | 100 hp and higher               | 4.0                                   | 4.00                                 |
| 60.4230 Table 1           | Gas         | VOC              | 100 hp and higher               | 1.0                                   | 0.29                                 |

### **3.1.5 Applicability of National Emission Standards for Hazardous Air Pollutants (NESHAPS)**

Section 112 of the Clean Air Act required the USEPA to list categories and subcategories of major sources and area sources of hazardous air pollutants (HAP) and to establish NESHAPS for the listed source categories and subcategories. NESHAPS require all major sources to meet HAP emission standards reflecting the application of the maximum achievable control technology (MACT). Compressor Station 26 is not a major source of HAPS and is, therefore, not subject to any applicable NESHAPS.

### **3.1.6 Applicability of Title V**

In 1990, Congress established an operating permit program under Title V of the Clean Air Act Amendments. This operating permit program streamlines the way federal, state, tribal, and local authorities regulate air pollution by consolidating all air pollution control requirements into a single, comprehensive "operating permit" that covers all aspects of a source's year-to-year air pollution activities.

All "major" stationary sources emitting certain air pollutants are required to obtain operating permits. Generally, major sources include those stationary facilities that emit 100 tons or more per year of a regulated air pollutant. Smaller sources are considered "major" in areas that are not meeting the national air quality standards for a particular pollutant. Also, sources of toxic air pollutants (i.e., any source that emits more than 10 tons per year of an individual toxic air pollutant or more than 25 tons per year of any combination of toxic air pollutants) are considered major.

Currently CS 26 is not a major source under Title V definitions and will remain so after the

addition of the new emissions proposed by this project; therefore, CS 26 will not be required to obtain a Title V operating permit.

### **3.2 Florida state air Quality Regulations**

Compressor Station No. 26 is currently operating under Permit No.0041004-014-OA and is subject to the provisions of that permit. Rule 62, F.A.C., contains the air quality rules and regulations for the State of Florida. The primary federal regulations that affect Compressor Station No. 26 have been incorporated into or are referenced by these rules. The significant state regulations that are applicable to the new emission units are briefly listed below.

#### **3.2.1 Rule 62-210.300 Permits Required**

FGT is required to obtain a construction permit prior to modification of an emission unit. This requirement is being met by the submittal of this application. After the modification, FGT will be required to modify the state operating permit to incorporate the new sources.

#### **3.2.2 Rule 62-204.240 Ambient Air Quality Standards**

FGT must not violate any of the ambient air quality standards listed under this rule. The proposed new emissions will not violate any air quality standards. .

#### **3.2.3 Rule 62-296.320(2) Objectionable Odors**

This rule prohibits the discharge of pollutants that will cause or contribute to an objectionable odor. There will be no odors from the proposed changes.

#### **3.2.4 Rule 62-296.320(4)(b)1 General Particulate Emission Limiting Standards**

FGT is prohibited from allowing the new compressor engine to discharge into the atmosphere the emissions of air pollutants, the density of which is equal to or greater than that designated as Number 1 on the Ringelmann Chart (20 percent opacity). The new engines will not violate this standard.



---

#### 4.0 REFERENCES

U.S. Environmental Protection Agency (USEPA). 1980. PSD Workshop Manual. Research Triangle Park, NC.

U.S. Environmental Protection Agency (USEPA). 1985. Protocol for Equipment Leak Emission Estimates, EPA-453/R-95-017

U.S. Environmental Protection Agency (USEPA). 2000. Compilation of Air Pollutant Emission Factors, Volume I: Stationary Point and Area Sources (5<sup>th</sup> Ed.) AP-42. Supplement E, Research Triangle Park, NC.

**Attachment A**

**DEP Forms**

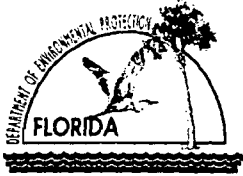

# Department of Environmental Protection

## Division of Air Resource Management

### APPLICATION FOR AIR PERMIT - LONG FORM

**RECEIVED**  
NOV 26 2008  
BUREAU OF AIR REGULATION

#### I. APPLICATION INFORMATION

**Air Construction Permit** – Use this form to apply for an air construction permit:

- For any required purpose at a facility operating under a federally enforceable state air operation permit (FESOP) or Title V air operation permit;
- For a proposed project subject to prevention of significant deterioration (PSD) review, nonattainment new source review, or maximum achievable control technology (MACT);
- To assume a restriction on the potential emissions of one or more pollutants to escape a requirement such as PSD review, nonattainment new source review, MACT, or Title V; or
- To establish, revise, or renew a plantwide applicability limit (PAL).

**Air Operation Permit** – Use this form to apply for:

- An initial federally enforceable state air operation permit (FESOP); or
- An initial, revised, or renewal Title V air operation permit.

**To ensure accuracy, please see form instructions.**

#### Identification of Facility

|  |  |
|--|--|
| 1. Facility Owner/Company Name: Florida Gas Transmission Company, LLC  |  |
| 2. Site Name: Compressor Station No. 26  |  |
| 3. Facility Identification Number: 0170035   |  |
| 4. Facility Location...<br>Street Address or Other Locator: 245 N. Maylen Road<br>City: Lecanto                      County: Citrus                      Zip Code: 34461 |  |
| 5. Relocatable Facility?<br><input type="checkbox"/> Yes <input checked="" type="checkbox"/> No  | 6. Existing Title V Permitted Facility?<br><input type="checkbox"/> Yes <input checked="" type="checkbox"/> No |

#### Application Contact

|   |  |
|---|--|
| 1. Application Contact Name: Charles Wait   |  |
| 2. Application Contact Mailing Address...<br>Organization/Firm: Florida Gas Transmission Company, LLC<br>Street Address: 5444 Westheimer<br>City: Houston                      State: TX                      Zip Code: 77056 |  |
| 3. Application Contact Telephone Numbers...<br>Telephone: ( 713 ) 989 - 7459      ext.      Fax: ( 713 ) 989 - 1135   |  |
| 4. Application Contact E-mail Address: charles.wait@SUG.com   |  |

#### Application Processing Information (DEP Use)

|   |                                   |
|---|-----------------------------------|
| 1. Date of Receipt of Application: 11-26-08 | 3. PSD Number (if applicable):    |
| 2. Project Number(s): 0170035-012-AC        | 4. Siting Number (if applicable): |

## APPLICATION INFORMATION

### Purpose of Application

**This application for air permit is being submitted to obtain: (Check one)**

#### **Air Construction Permit**

- Air construction permit.
- Air construction permit to establish, revise, or renew a plantwide applicability limit (PAL).
- Air construction permit to establish, revise, or renew a plantwide applicability limit (PAL), and separate air construction permit to authorize construction or modification of one or more emissions units covered by the PAL.

#### **Air Operation Permit**

- Initial Title V air operation permit.
- Title V air operation permit revision.
- Title V air operation permit renewal.
- Initial federally enforceable state air operation permit (FESOP) where professional engineer (PE) certification is required.
- Initial federally enforceable state air operation permit (FESOP) where professional engineer (PE) certification is not required.

#### **Air Construction Permit and Revised/Renewal Title V Air Operation Permit (Concurrent Processing)**

- Air construction permit and Title V permit revision, incorporating the proposed project.
- Air construction permit and Title V permit renewal, incorporating the proposed project.

**Note: By checking one of the above two boxes, you, the applicant, are requesting concurrent processing pursuant to Rule 62-213.405, F.A.C. In such case, you must also check the following box:**

- I hereby request that the department waive the processing time requirements of the air construction permit to accommodate the processing time frames of the Title V air operation permit.

### Application Comment

Florida Gas Transmission Company is proposing to install a new 20,500 bhp gas-fire compressor turbine and two new 454 bhp gas-fired SI ICE 4-stroke rich-burn emergency generator engines.

These proposed modifications are part of FGT's Phase VIII Expansion project, aimed at increasing the supply capacity of FGT's network servicing domestic, commercial, and industrial customers in Florida.



**APPLICATION INFORMATION**

**Owner/Authorized Representative Statement**

**Complete if applying for an air construction permit or an initial FESOP.**

|   |
|---|
| 1. Owner/Authorized Representative Name :<br>David Shellhouse, Vice President, Southeastern Operations  |
| 2. Owner/Authorized Representative Mailing Address<br>Organization/Firm: Florida Gas Transmission Company, LLC<br>Street Address: 2405 Lucien Way, Suite 200<br>City: Maitland State: FL Zip Code: 32751  |
| 3. Owner/Authorized Representative Telephone Numbers...<br>Telephone: ( 407 ) 838 - 7122 ext. Fax: ( 407 ) 838 - 7151   |
| 4. Owner/Authorized Representative E-mail Address: <u>dave.shellhouse@SUG.com</u>   |
| 5. Owner/Authorized Representative Statement:<br><br><i>I, the undersigned, am the owner or authorized representative of the corporation, partnership, or other legal entity submitting this air permit application. To the best of my knowledge, the statements made in this application are true, accurate and complete, and any estimates of emissions reported in this application are based upon reasonable techniques for calculating emissions. I understand that a permit, if granted by the department, cannot be transferred without authorization from the department.</i><br><br>Signature <u></u> Date <u>11-25-08</u><br><i>on behalf of David Shellhouse</i> |

## APPLICATION INFORMATION

### Application Responsible Official Certification

**Complete if applying for an initial, revised, or renewal Title V air operation permit or concurrent processing of an air construction permit and revised or renewal Title V air operation permit. If there are multiple responsible officials, the "application responsible official" need not be the "primary responsible official."**

|   |
|---|
| 1. Application Responsible Official Name: NA  |
| 2. Application Responsible Official Qualification (Check one or more of the following options, as applicable):<br><input type="checkbox"/> For a corporation, the president, secretary, treasurer, or vice-president of the corporation in charge of a principal business function, or any other person who performs similar policy or decision-making functions for the corporation, or a duly authorized representative of such person if the representative is responsible for the overall operation of one or more manufacturing, production, or operating facilities applying for or subject to a permit under Chapter 62-213, F.A.C.<br><input type="checkbox"/> For a partnership or sole proprietorship, a general partner or the proprietor, respectively.<br><input type="checkbox"/> For a municipality, county, state, federal, or other public agency, either a principal executive officer or ranking elected official.<br><input type="checkbox"/> The designated representative at an Acid Rain source, CAIR source, or Hg Budget source.   |
| 3. Application Responsible Official Mailing Address...<br>Organization/Firm:<br>Street Address:<br>City: State: Zip Code:   |
| 4. Application Responsible Official Telephone Numbers...<br>Telephone: ( ) - ext. Fax: ( ) -  |
| 5. Application Responsible Official E-mail Address:   |
| 6. Application Responsible Official Certification:<br><i>I, the undersigned, am a responsible official of the Title V source addressed in this air permit application. I hereby certify, based on information and belief formed after reasonable inquiry, that the statements made in this application are true, accurate and complete and that, to the best of my knowledge, any estimates of emissions reported in this application are based upon reasonable techniques for calculating emissions. The air pollutant emissions units and air pollution control equipment described in this application will be operated and maintained so as to comply with all applicable standards for control of air pollutant emissions found in the statutes of the State of Florida and rules of the Department of Environmental Protection and revisions thereof and all other applicable requirements identified in this application to which the Title V source is subject. I understand that a permit, if granted by the department, cannot be transferred without authorization from the department, and I will promptly notify the department upon sale or legal transfer of the facility or any permitted emissions unit. Finally, I certify that the facility and each emissions unit are in compliance with all applicable requirements to which they are subject, except as identified in compliance plan(s) submitted with this application.</i><br><br>_____<br>Signature<br><br>_____<br>Date |

# APPLICATION INFORMATION

## Professional Engineer Certification

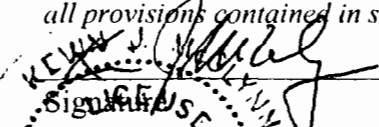
|  |
|--|
| 1. Professional Engineer Name: Kevin J. McGlynn<br>Registration Number: 50908  |
| 2. Professional Engineer Mailing Address.<br>Organization/Firm: Trow Engineering consultants, Inc.<br>Street Address: 1200 Metropolitan Blvd. Ste. 200<br>City: Tallahassee State: FL Zip Code: 32308  |
| 3. Professional Engineer Telephone Numbers.<br>Telephone: ( 850 ) 385 - 5441 ext. 314 Fax: ( 850 ) 385 - 5523  |
| 4. Professional Engineer E-mail Address: <u>Kevin.mcglynn@trow.com</u>   |
| 5. Professional Engineer Statement:<br><i>I, the undersigned, hereby certify, except as particularly noted herein*, that:</i><br><i>(1) To the best of my knowledge, there is reasonable assurance that the air pollutant emissions unit(s) and the air pollution control equipment described in this application for air permit, when properly operated and maintained, will comply with all applicable standards for control of air pollutant emissions found in the Florida Statutes and rules of the Department of Environmental Protection; and</i><br><i>(2) To the best of my knowledge, any emission estimates reported or relied on in this application are true, accurate, and complete and are either based upon reasonable techniques available for calculating emissions or, for emission estimates of hazardous air pollutants not regulated for an emissions unit addressed in this application, based solely upon the materials, information and calculations submitted with this application.</i><br><i>(3) If the purpose of this application is to obtain a Title V air operation permit (check here <input type="checkbox"/> , if so), I further certify that each emissions unit described in this application for air permit, when properly operated and maintained, will comply with the applicable requirements identified in this application to which the unit is subject, except those emissions units for which a compliance plan and schedule is submitted with this application.</i><br><i>(4) If the purpose of this application is to obtain an air construction permit (check here <input checked="" type="checkbox"/> , if so) or concurrently process and obtain an air construction permit and a Title V air operation permit revision or renewal for one or more proposed new or modified emissions units (check here <input type="checkbox"/> , if so), I further certify that the engineering features of each such emissions unit described in this application have been designed or examined by me or individuals under my direct supervision and found to be in conformity with sound engineering principles applicable to the control of emissions of the air pollutants characterized in this application.</i><br><i>(5) If the purpose of this application is to obtain an initial air operation permit or operation permit revision or renewal for one or more newly constructed or modified emissions units (check here <input type="checkbox"/> , if so), I further certify that, with the exception of any changes detailed as part of this application, each such emissions unit has been constructed or modified in substantial accordance with the information given in the corresponding application for air construction permit and with all provisions contained in such permit.</i><br><br><br>_____<br>Signature<br>(Seal) 50908<br><br>Nov. 18, 2008<br>Date |

\* Attach any exception to certification statement.

PROF. ENGINEER  
STATE OF FLORIDA  
DEP Form No. 62-210-900(1) - Form  
Effective 3/16/08



**II. FACILITY INFORMATION**  
**A. GENERAL FACILITY INFORMATION**

**Facility Location and Type**

|  |                          |                                   |                               |
|--|--------------------------|-----------------------------------|-------------------------------|
| 1. Facility UTM Coordinates...   |                          | 2. Facility Latitude/Longitude... |                               |
| Zone 17  | East (km) 353.212        | Latitude (DD/MM/SS) 28/51/58      | Longitude (DD/MM/SS) 82/30/18 |
|  | North (km) 3193.987      |                                   |                               |
| 3. Governmental Facility Code:   | 4. Facility Status Code: | 5. Facility Major Group SIC Code: | 6. Facility SIC(s):           |
| 0  | A                        | 49                                | 4922                          |
| 7. Facility Comment :  |                          |                                   |                               |
| Compressor Station No. 26 is an existing natural gas pipeline compressor station with two compressor turbines. |                          |                                   |                               |

**Facility Contact**

|  |
|--|
| 1. Facility Contact Name: : Bob Thompson   |
| 2. Facility Contact Mailing Address:<br>Organization/Firm: Florida Gas Transmission Company<br>Street Address: 245 N. Maylen Road<br>City: Lecanto State: FL Zip Code: 34461 |
| 3. Facility Contact Telephone Numbers:<br>Telephone: ( 407 ) 838 - 7605 ext. Fax: ( 407 ) 838 - 7601   |
| 4. Facility Contact E-mail Address: <u>Bob.Thompson@SUG.com</u>  |

**Facility Primary Responsible Official**

**Complete if an "application responsible official" is identified in Section I that is not the facility "primary responsible official."**

|  |
|--|
| 1. Facility Primary Responsible Official Name:<br>NA   |
| 2. Facility Primary Responsible Official Mailing Address...<br>Organization/Firm:<br>Street Address:<br>City: State: Zip Code: |
| 3. Facility Primary Responsible Official Telephone Numbers...<br>Telephone: ( ) - ext. Fax: ( ) -                              |
| 4. Facility Primary Responsible Official E-mail Address:   |

## FACILITY INFORMATION

### Facility Regulatory Classifications

Check all that would apply *following* completion of all projects and implementation of all other changes proposed in this application for air permit. Refer to instructions to distinguish between a "major source" and a "synthetic minor source."

|     |  |                                  |
|-----|--|----------------------------------|
| 1.  | <input type="checkbox"/> Small Business Stationary Source  | <input type="checkbox"/> Unknown |
| 2.  | <input type="checkbox"/> Synthetic Non-Title V Source  |                                  |
| 3.  | <input type="checkbox"/> Title V Source  |                                  |
| 4.  | <input type="checkbox"/> Major Source of Air Pollutants, Other than Hazardous Air Pollutants (HAPs)  |                                  |
| 5.  | <input type="checkbox"/> Synthetic Minor Source of Air Pollutants, Other than HAPs   |                                  |
| 6.  | <input type="checkbox"/> Major Source of Hazardous Air Pollutants (HAPs)   |                                  |
| 7.  | <input type="checkbox"/> Synthetic Minor Source of HAPs  |                                  |
| 8.  | <input checked="" type="checkbox"/> One or More Emissions Units Subject to NSPS (40 CFR Part 60)   |                                  |
| 9.  | <input type="checkbox"/> One or More Emissions Units Subject to Emission Guidelines (40 CFR Part 60)   |                                  |
| 10. | <input type="checkbox"/> One or More Emissions Units Subject to NESHAP (40 CFR Part 61 or Part 63)   |                                  |
| 11. | <input type="checkbox"/> Title V Source Solely by EPA Designation (40 CFR 70.3(a)(5))  |                                  |
| 12. | Facility Regulatory Classifications Comment:<br><br>Facility will be a major source of Air Pollutants after these modifications.<br><br>New gas-fired compressor turbine (No. 2603) is subject to (NSPS) 40 CFR Part 60, Subpart KKKK<br><br>New gas-fired reciprocating internal combustion emergency generator engines are subject to (NSPS) 40 CFR 60 Subpart JJJJ. |                                  |

## FACILITY INFORMATION

### List of Pollutants Emitted by Facility

| 1. Pollutant Emitted | 2. Pollutant Classification | 3. Emissions Cap [Y or N]? |
|----------------------|-----------------------------|----------------------------|
| NOX                  | B                           | N                          |
| CO                   | B                           | N                          |
| VOC                  | B                           | N                          |
| SO2                  | B                           | N                          |
| PM                   | B                           | N                          |
| HAP                  | B                           | N                          |
|                      |                             |                            |
|                      |                             |                            |
|                      |                             |                            |
|                      |                             |                            |
|                      |                             |                            |
|                      |                             |                            |
|                      |                             |                            |
|                      |                             |                            |
|                      |                             |                            |
|                      |                             |                            |
|                      |                             |                            |



## FACILITY INFORMATION

### C. FACILITY ADDITIONAL INFORMATION

#### Additional Requirements for All Applications, Except as Otherwise Stated

|   |
|---|
| 1. Facility Plot Plan: (Required for all permit applications, except Title V air operation permit revision applications if this information was submitted to the department within the previous five years and would not be altered as a result of the revision being sought)<br><input checked="" type="checkbox"/> Attached, Document ID: <u>Attach. D</u> <input type="checkbox"/> Previously Submitted, Date: _____   |
| 2. Process Flow Diagram(s): (Required for all permit applications, except Title V air operation permit revision applications if this information was submitted to the department within the previous five years and would not be altered as a result of the revision being sought)<br><input checked="" type="checkbox"/> Attached, Document ID: <u>Attach. B</u> <input type="checkbox"/> Previously Submitted, Date: _____  |
| 3. Precautions to Prevent Emissions of Unconfined Particulate Matter: (Required for all permit applications, except Title V air operation permit revision applications if this information was submitted to the department within the previous five years and would not be altered as a result of the revision being sought)<br><input checked="" type="checkbox"/> Attached, Document ID <u>Attach. C</u> <input type="checkbox"/> Previously Submitted, Date: _____ |

#### Additional Requirements for Air Construction Permit Applications

|   |
|---|
| 1. Area Map Showing Facility Location:<br><input checked="" type="checkbox"/> Attached, Document ID: <u>Narr.Fig. 1-1</u> <input type="checkbox"/> Not Applicable (existing permitted facility) |
| 2. Description of Proposed Construction, Modification, or Plantwide Applicability Limit (PAL):<br><input checked="" type="checkbox"/> Attached, Document ID: <u>Narr.Sect 2.0</u>               |
| 3. Rule Applicability Analysis:<br><input checked="" type="checkbox"/> Attached, Document ID: <u>Narr.Sect 3.0</u>  |
| 4. List of Exempt Emissions Units:<br><input checked="" type="checkbox"/> Attached, Document ID: <u>Attach. H</u> <input type="checkbox"/> Not Applicable (no exempt units at facility)         |
| 5. Fugitive Emissions Identification:<br><input checked="" type="checkbox"/> Attached, Document ID: <u>Narr.Sect 2.2.5</u> <input type="checkbox"/> Not Applicable                              |
| 6. Air Quality Analysis (Rule 62-212.400(7), F.A.C.):<br><input type="checkbox"/> Attached, Document ID: _____ <input checked="" type="checkbox"/> Not Applicable                               |
| 7. Source Impact Analysis (Rule 62-212.400(5), F.A.C.):<br><input type="checkbox"/> Attached, Document ID: _____ <input checked="" type="checkbox"/> Not Applicable                             |
| 8. Air Quality Impact since 1977 (Rule 62-212.400(4)(e), F.A.C.):<br><input type="checkbox"/> Attached, Document ID: _____ <input checked="" type="checkbox"/> Not Applicable                   |
| 9. Additional Impact Analyses (Rules 62-212.400(8) and 62-212.500(4)(e), F.A.C.):<br><input type="checkbox"/> Attached, Document ID: _____ <input checked="" type="checkbox"/> Not Applicable   |
| 10. Alternative Analysis Requirement (Rule 62-212.500(4)(g), F.A.C.):<br><input type="checkbox"/> Attached, Document ID: _____ <input checked="" type="checkbox"/> Not Applicable               |

**FACILITY INFORMATION**

**C. FACILITY ADDITIONAL INFORMATION (CONTINUED)**

**Additional Requirements for FESOP Applications**

|   |
|---|
| 1. List of Exempt Emissions Units:<br><input type="checkbox"/> Attached, Document ID: <u>NA</u> <input type="checkbox"/> Not Applicable (no exempt units at facility) |
|---|

**Additional Requirements for Title V Air Operation Permit Applications**

|  |
|--|
| 1. List of Insignificant Activities: (Required for initial/renewal applications only)<br><input type="checkbox"/> Attached, Document ID: <u>NA</u> <input type="checkbox"/> Not Applicable (revision application)  |
| 2. Identification of Applicable Requirements: (Required for initial/renewal applications, and for revision applications if this information would be changed as a result of the revision being sought)<br><input type="checkbox"/> Attached, Document ID: <u>NA</u><br><input type="checkbox"/> Not Applicable (revision application with no change in applicable requirements)  |
| 3. Compliance Report and Plan: (Required for all initial/revision/renewal applications)<br><input type="checkbox"/> Attached, Document ID: <u>NA</u><br>Note: A compliance plan must be submitted for each emissions unit that is not in compliance with all applicable requirements at the time of application and/or at any time during application processing. The department must be notified of any changes in compliance status during application processing. |
| 4. List of Equipment/Activities Regulated under Title VI: (If applicable, required for initial/renewal applications only)<br><input type="checkbox"/> Attached, Document ID: <u>NA</u><br><input type="checkbox"/> Equipment/Activities Onsite but Not Required to be Individually Listed<br><input type="checkbox"/> Not Applicable   |
| 5. Verification of Risk Management Plan Submission to EPA: (If applicable, required for initial/renewal applications only)<br><input type="checkbox"/> Attached, Document ID: <u>NA</u> <input type="checkbox"/> Not Applicable  |
| 6. Requested Changes to Current Title V Air Operation Permit:<br><input type="checkbox"/> Attached, Document ID: <u>NA</u> <input type="checkbox"/> Not Applicable   |

## FACILITY INFORMATION

### C. FACILITY ADDITIONAL INFORMATION (CONTINUED)

#### Additional Requirements for Facilities Subject to Acid Rain, CAIR, or Hg Budget Program

1. Acid Rain Program Forms: NA

Acid Rain Part Application (DEP Form No. 62-210.900(1)(a)):

Attached, Document ID: \_\_\_\_\_  Previously Submitted, Date: \_\_\_\_\_

Not Applicable (not an Acid Rain source)

Phase II NO<sub>x</sub> Averaging Plan (DEP Form No. 62-210.900(1)(a)1.):

Attached, Document ID: \_\_\_\_\_  Previously Submitted, Date: \_\_\_\_\_

Not Applicable

New Unit Exemption (DEP Form No. 62-210.900(1)(a)2.):

Attached, Document ID: \_\_\_\_\_  Previously Submitted, Date: \_\_\_\_\_

Not Applicable

2. CAIR Part (DEP Form No. 62-210.900(1)(b)): NA

Attached, Document ID: \_\_\_\_\_  Previously Submitted, Date: \_\_\_\_\_

Not Applicable (not a CAIR source)

3. Hg Budget Part (DEP Form No. 62-210.900(1)(c)): NA

Attached, Document ID: \_\_\_\_\_  Previously Submitted, Date: \_\_\_\_\_

Not Applicable (not a Hg Budget unit)

#### Additional Requirements Comment

Attachment B provides a Process Flow Diagram

Attachment C presents Precautions to Prevent Emissions of Unconfined Particulate Matter

Attachment D contains a plot plan.

Attachment E has vendor supplied information.

Attachment F has supporting calculations.

Attachment G contains a fuel analysis

Attachment H contains a list of Exempt Emission Units

**EMISSIONS UNIT INFORMATION**

Section [ 1 ] of [ 3 ]

**A. GENERAL EMISSIONS UNIT INFORMATION**

**Title V Air Operation Permit Emissions Unit Classification**

1. Regulated or Unregulated Emissions Unit? (Check one, if applying for an initial, revised or renewal Title V air operation permit. Skip this item if applying for an air construction permit or FESOP only.) NA

The emissions unit addressed in this Emissions Unit Information Section is a regulated emissions unit.

The emissions unit addressed in this Emissions Unit Information Section is an unregulated emissions unit.

**Emissions Unit Description and Status**

1. Type of Emissions Unit Addressed in this Section: (Check one)

This Emissions Unit Information Section addresses, as a single emissions unit, a single process or production unit, or activity, which produces one or more air pollutants and which has at least one definable emission point (stack or vent).

This Emissions Unit Information Section addresses, as a single emissions unit, a group of process or production units and activities which has at least one definable emission point (stack or vent) but may also produce fugitive emissions.

This Emissions Unit Information Section addresses, as a single emissions unit, one or more process or production units and activities which produce fugitive emissions only.

2. Description of Emissions Unit Addressed in this Section:

20,500 bhp (ISO) natural gas fired turbine compressor unit, FGT Engine No. 2603

3. Emissions Unit Identification Number: 003

|   |  |                                    |   |
|---|--|------------------------------------|---|
| 4. Emissions Unit Status Code:<br><br>C | 5. Commence Construction Date:<br><br>NA | 6. Initial Startup Date:<br><br>NA | 7. Emissions Unit Major Group SIC Code:<br><br>49 |
|---|--|------------------------------------|---|

8. Federal Program Applicability: (Check all that apply)

Acid Rain Unit

CAIR Unit

Hg Budget Unit

9. Package Unit:  
Manufacturer: Solar Model Number: Titan 130 - 20502S

10. Generator Nameplate Rating: MW

11. Emissions Unit Comment:

Fuel will be exclusively natural gas from the FGT's gas pipeline. The proposed engine will incorporate dry, low NO<sub>x</sub> combustion technology.



**EMISSIONS UNIT INFORMATION**

Section [ 1 ] of [ 3 ]

**Emissions Unit Control Equipment/Method:** Control  1  of  1

1. Control Equipment/Method Description:

The proposed engine will incorporate dry, low NO<sub>x</sub> combustion technology.

2. Control Device or Method Code: 99

**Emissions Unit Control Equipment/Method:** Control   of

1. Control Equipment/Method Description:

2. Control Device or Method Code:

**Emissions Unit Control Equipment/Method:** Control   of

1. Control Equipment/Method Description:

2. Control Device or Method Code:

**Emissions Unit Control Equipment/Method:** Control   of

1. Control Equipment/Method Description:

2. Control Device or Method Code:

**EMISSIONS UNIT INFORMATION**

Section [ 1 ] of [ 3 ]

**B. EMISSIONS UNIT CAPACITY INFORMATION**

(Optional for unregulated emissions units.)

**Emissions Unit Operating Capacity and Schedule**

|   |
|---|
| 1. Maximum Process or Throughput Rate: NA   |
| 2. Maximum Production Rate: NA  |
| 3. Maximum Heat Input Rate: 157.89 million Btu/hr HHV   |
| 4. Maximum Incineration Rate: pounds/hr NA<br>tons/day  |
| 5. Requested Maximum Operating Schedule:<br>24 hours/day 7 days/week<br>52 weeks/year 8760 hours/year   |
| 6. Operating Capacity/Schedule Comment:<br><br>Heat input is 157.89 MM Btu/hr Higher heating value (HHV). This is based on a vendor provided bhp of 19,465 bhp, a specific heat rate of 7,326 Btu/hp-hr, a lower heating value (LHV) of 939.2 Btu/scf and a higher heating value (HHV) of 1040 Btu/scf. |

**EMISSIONS UNIT INFORMATION**

Section | 1 | of | 3 |

**C. EMISSION POINT (STACK/VENT) INFORMATION**

(Optional for unregulated emissions units.)

**Emission Point Description and Type**

|   |   |   |                                    |
|---|---|---|------------------------------------|
| 1. Identification of Point on Plot Plan or Flow Diagram: 2603   |   | 2. Emission Point Type Code:<br>1   |                                    |
| 3. Descriptions of Emission Points Comprising this Emissions Unit for VE Tracking:<br><br>NA            |   |   |                                    |
| 4. ID Numbers or Descriptions of Emission Units with this Emission Point in Common:<br><br>NA           |   |   |                                    |
| 5. Discharge Type Code:<br>V  | 6. Stack Height:<br>55 Feet                     |   | 7. Exit Diameter:<br>8.7 feet (De) |
| 8. Exit Temperature:<br>944 °F  | 9. Actual Volumetric Flow Rate:<br>232,782 acfm |   | 10. Water Vapor:<br>NA %           |
| 11. Maximum Dry Standard Flow Rate:<br>NA dscfm   |   | 12. Nonstack Emission Point Height:<br>NA feet  |                                    |
| 13. Emission Point UTM Coordinates...<br>Zone: 17 East (km): 353.212<br>North (km): 3193.987            |   | 14. Emission Point Latitude/Longitude...<br>Latitude (DD/MM/SS)<br>Longitude (DD/MM/SS) |                                    |
| 15. Emission Point Comment:<br><br>Stack has rectangular cross section with dimensions of 7.5 x 8 feet. |   |   |                                    |

**EMISSIONS UNIT INFORMATION**

Section | 1 | of | 3 |

**D. SEGMENT (PROCESS/FUEL) INFORMATION**

**Segment Description and Rate:** Segment 1 of 1

|  |                                    |  |
|--|------------------------------------|--|
| 1. Segment Description (Process/Fuel Type):<br><br>Natural gas fired turbine engine driving a natural gas compressor, operating full time. |                                    |  |
| 2. Source Classification Code (SCC):<br>2-02-002-01  |                                    | 3. SCC Units:<br>million cubic feet burned |
| 4. Maximum Hourly Rate:<br>0.1518  | 5. Maximum Annual Rate:<br>1329.92 | 6. Estimated Annual Activity Factor:<br>NA |
| 7. Maximum % Sulfur:<br>NA   | 8. Maximum % Ash:<br>NA            | 9. Million Btu per SCC Unit:<br>1040       |
| 10. Segment Comment:<br><br>None   |                                    |  |

**Segment Description and Rate:** Segment    of   

|   |                         |                                      |
|---|-------------------------|--------------------------------------|
| 1. Segment Description (Process/Fuel Type):<br><br> |                         |                                      |
| 2. Source Classification Code (SCC):                |                         | 3. SCC Units:                        |
| 4. Maximum Hourly Rate:                             | 5. Maximum Annual Rate: | 6. Estimated Annual Activity Factor: |
| 7. Maximum % Sulfur:                                | 8. Maximum % Ash:       | 9. Million Btu per SCC Unit:         |
| 10. Segment Comment:<br><br>                        |                         |                                      |



**EMISSIONS UNIT INFORMATION**

Section [ 1 ] of [ 3 ]

**POLLUTANT DETAIL INFORMATION**

Page [ 1 ] of [ 6 ]

**F1. EMISSIONS UNIT POLLUTANT DETAIL INFORMATION –  
POTENTIAL, FUGITIVE, AND ACTUAL EMISSIONS  
(Optional for unregulated emissions units.)**

**Complete a Subsection F1 for each pollutant identified in Subsection E if applying for an air construction permit or concurrent processing of an air construction permit and a revised or renewal Title V operation permit. Complete for each emissions-limited pollutant identified in Subsection E if applying for an air operation permit.**

**Potential, Estimated Fugitive, and Baseline & Projected Actual Emissions**

|  |  |   |  |
|--|--|---|--|
| 1. Pollutant Emitted:<br>NOX   |  | 2. Total Percent Efficiency of Control:   |  |
| 3. Potential Emissions:<br>8.52 lb/hour                      37.31 tons/year   |  | 4. Synthetically Limited?<br><input type="checkbox"/> Yes <input checked="" type="checkbox"/> No        |  |
| 5. Range of Estimated Fugitive Emissions (as applicable): NA<br>to tons/year   |  |   |  |
| 6. Emission Factor: 8.52 lb/hr<br><br>Reference: Vendor data   |  | 7. Emissions Method Code:<br>5  |  |
| 8.a. Baseline Actual Emissions (if required):<br>NA tons/year  |  | 8.b. Baseline 24-month Period:<br>From:                      To:  |  |
| 9.a. Projected Actual Emissions (if required):<br>NA tons/year   |  | 9.b. Projected Monitoring Period:<br><input type="checkbox"/> 5 years <input type="checkbox"/> 10 years |  |
| 10. Calculation of Emissions:<br><br>$(8.52 \text{ lb/hr})(1 \text{ ton}/2000 \text{ lb})(8760 \text{ hr}/1 \text{ yr}) = 37.31 \text{ tons/year}$ |  |   |  |
| 11. Potential, Fugitive, and Actual Emissions Comment:<br><br>Vendor's data based on ISO conditions with inlet and exhaust losses of 4" of H2O.    |  |   |  |

**F2. EMISSIONS UNIT POLLUTANT DETAIL INFORMATION -  
ALLOWABLE EMISSIONS**

**Complete Subsection F2 if the pollutant identified in Subsection F1 is or would be subject to a numerical emissions limitation.**

**Allowable Emissions** Allowable Emissions 1 of 1

|   |   |
|---|---|
| 1. Basis for Allowable Emissions Code:<br>RULE  | 2. Future Effective Date of Allowable Emissions: NA                                     |
| 3. Allowable Emissions and Units:<br>15 ppmvd @ 15% O2  | 4. Equivalent Allowable Emissions:<br>8.52 lb/hour                      37.31 tons/year |
| 5. Method of Compliance:<br>Initial performance test  |   |
| 6. Allowable Emissions Comment (Description of Operating Method):<br><br>40 CFR 60.4320(a) limits NOX emissions to 25 ppmv. |   |

**Allowable Emissions** Allowable Emissions    of   

|   |  |
|---|--|
| 1. Basis for Allowable Emissions Code:                            | 2. Future Effective Date of Allowable Emissions:                             |
| 3. Allowable Emissions and Units:                                 | 4. Equivalent Allowable Emissions:<br>lb/hour                      tons/year |
| 5. Method of Compliance:  |  |
| 6. Allowable Emissions Comment (Description of Operating Method): |  |

**Allowable Emissions** Allowable Emissions    of   

|   |  |
|---|--|
| 1. Basis for Allowable Emissions Code:                            | 2. Future Effective Date of Allowable Emissions:                             |
| 3. Allowable Emissions and Units:                                 | 4. Equivalent Allowable Emissions:<br>lb/hour                      tons/year |
| 5. Method of Compliance:  |  |
| 6. Allowable Emissions Comment (Description of Operating Method): |  |

**EMISSIONS UNIT INFORMATION**

Section | 1 | of | 3 |

**POLLUTANT DETAIL INFORMATION**

Page | 2 | of | 6 |

**F1. EMISSIONS UNIT POLLUTANT DETAIL INFORMATION –  
POTENTIAL, FUGITIVE, AND ACTUAL EMISSIONS  
(Optional for unregulated emissions units.)**

**Complete a Subsection F1 for each pollutant identified in Subsection E if applying for an air construction permit or concurrent processing of an air construction permit and a revised or renewal Title V operation permit. Complete for each emissions-limited pollutant identified in Subsection E if applying for an air operation permit.**

**Potential, Estimated Fugitive, and Baseline & Projected Actual Emissions**

|  |  |   |  |
|--|--|---|--|
| 1. Pollutant Emitted:<br>CO  |  | 2. Total Percent Efficiency of Control:   |  |
| 3. Potential Emissions:<br>8.64 lb/hour                      37.84 tons/year   |  | 4. Synthetically Limited?<br><input type="checkbox"/> Yes <input checked="" type="checkbox"/> No        |  |
| 5. Range of Estimated Fugitive Emissions (as applicable): NA<br>to tons/year   |  |   |  |
| 6. Emission Factor: 8.64 lb/hr<br><br>Reference: Vendor data   |  | 7. Emissions Method Code:<br>5  |  |
| 8.a. Baseline Actual Emissions (if required):<br>NA tons/year  |  | 8.b. Baseline 24-month Period:<br>From:                      To:  |  |
| 9.a. Projected Actual Emissions (if required):<br>NA tons/year   |  | 9.b. Projected Monitoring Period:<br><input type="checkbox"/> 5 years <input type="checkbox"/> 10 years |  |
| 10. Calculation of Emissions:<br><br>$(8.64 \text{ lb/hr})(1 \text{ ton}/2000 \text{ lb})(8760 \text{ hr}/1 \text{ yr}) = 37.84 \text{ tons/year}$ |  |   |  |
| 11. Potential, Fugitive, and Actual Emissions Comment:<br><br>Vendor's data based on ISO conditions with inlet and exhaust losses of 4" of H2O.    |  |   |  |



**F2. EMISSIONS UNIT POLLUTANT DETAIL INFORMATION -  
ALLOWABLE EMISSIONS**

**Complete Subsection F2 if the pollutant identified in Subsection F1 is or would be subject to a numerical emissions limitation.**

**Allowable Emissions** Allowable Emissions NA of

|   |  |
|---|--|
| 1. Basis for Allowable Emissions Code:                            | 2. Future Effective Date of Allowable Emissions: NA                          |
| 3. Allowable Emissions and Units:                                 | 4. Equivalent Allowable Emissions:<br>lb/hour                      tons/year |
| 5. Method of Compliance:  |  |
| 6. Allowable Emissions Comment (Description of Operating Method): |  |

**Allowable Emissions** Allowable Emissions \_\_\_ of \_\_\_

|   |  |
|---|--|
| 1. Basis for Allowable Emissions Code:                            | 2. Future Effective Date of Allowable Emissions:                             |
| 3. Allowable Emissions and Units:                                 | 4. Equivalent Allowable Emissions:<br>lb/hour                      tons/year |
| 5. Method of Compliance:  |  |
| 6. Allowable Emissions Comment (Description of Operating Method): |  |

**Allowable Emissions** Allowable Emissions \_\_\_ of \_\_\_

|   |  |
|---|--|
| 1. Basis for Allowable Emissions Code:                            | 2. Future Effective Date of Allowable Emissions:                             |
| 3. Allowable Emissions and Units:                                 | 4. Equivalent Allowable Emissions:<br>lb/hour                      tons/year |
| 5. Method of Compliance:  |  |
| 6. Allowable Emissions Comment (Description of Operating Method): |  |

**F1. EMISSIONS UNIT POLLUTANT DETAIL INFORMATION –  
POTENTIAL, FUGITIVE, AND ACTUAL EMISSIONS  
(Optional for unregulated emissions units.)**

**Complete a Subsection F1 for each pollutant identified in Subsection E if applying for an air construction permit or concurrent processing of an air construction permit and a revised or renewal Title V operation permit. Complete for each emissions-limited pollutant identified in Subsection E if applying for an air operation permit.**

**Potential, Estimated Fugitive, and Baseline & Projected Actual Emissions**

|   |  |   |  |
|---|--|---|--|
| 1. Pollutant Emitted:<br>VOC  |  | 2. Total Percent Efficiency of Control:   |  |
| 3. Potential Emissions:<br>0.50 lb/hour                      2.17 tons/year   |  | 4. Synthetically Limited?<br><input type="checkbox"/> Yes <input checked="" type="checkbox"/> No        |  |
| 5. Range of Estimated Fugitive Emissions (as applicable): NA<br>to tons/year  |  |   |  |
| 6. Emission Factor: 0.50 lb/hr<br><br>Reference: Vendor data  |  | 7. Emissions Method Code:<br>5  |  |
| 8.a. Baseline Actual Emissions (if required):<br>NA tons/year   |  | 8.b. Baseline 24-month Period:<br>From:                      To:  |  |
| 9.a. Projected Actual Emissions (if required):<br>NA tons/year  |  | 9.b. Projected Monitoring Period:<br><input type="checkbox"/> 5 years <input type="checkbox"/> 10 years |  |
| 10. Calculation of Emissions:<br><br>$(0.50 \text{ lb/hr})(1 \text{ ton}/2000 \text{ lb})(8760\text{hr}/1 \text{ yr}) = 2.17 \text{ tons/year}$ |  |   |  |
| 11. Potential, Fugitive, and Actual Emissions Comment:<br><br>Vendor's data based on ISO conditions with inlet and exhaust losses of 4" of H2O. |  |   |  |

**EMISSIONS UNIT INFORMATION**

Section [ 1 ] of [ 3 ]

**POLLUTANT DETAIL INFORMATION**

Page [ 3 ] of [ 6 ]

**F2. EMISSIONS UNIT POLLUTANT DETAIL INFORMATION -  
ALLOWABLE EMISSIONS**

**Complete Subsection F2 if the pollutant identified in Subsection F1 is or would be subject to a numerical emissions limitation.**

**Allowable Emissions** Allowable Emissions NA of

|   |  |
|---|--|
| 1. Basis for Allowable Emissions Code:                            | 2. Future Effective Date of Allowable Emissions:                             |
| 3. Allowable Emissions and Units:                                 | 4. Equivalent Allowable Emissions:<br>lb/hour                      tons/year |
| 5. Method of Compliance:  |  |
| 6. Allowable Emissions Comment (Description of Operating Method): |  |

**Allowable Emissions** Allowable Emissions    of   

|   |  |
|---|--|
| 1. Basis for Allowable Emissions Code:                            | 2. Future Effective Date of Allowable Emissions:                             |
| 3. Allowable Emissions and Units:                                 | 4. Equivalent Allowable Emissions:<br>lb/hour                      tons/year |
| 5. Method of Compliance:  |  |
| 6. Allowable Emissions Comment (Description of Operating Method): |  |

**Allowable Emissions** Allowable Emissions    of   

|   |  |
|---|--|
| 1. Basis for Allowable Emissions Code:                            | 2. Future Effective Date of Allowable Emissions:                             |
| 3. Allowable Emissions and Units:                                 | 4. Equivalent Allowable Emissions:<br>lb/hour                      tons/year |
| 5. Method of Compliance:  |  |
| 6. Allowable Emissions Comment (Description of Operating Method): |  |

**EMISSIONS UNIT INFORMATION**

Section [ 1 ] of [ 3 ]

**POLLUTANT DETAIL INFORMATION**

Page [ 4 ] of [ 6 ]

**F1. EMISSIONS UNIT POLLUTANT DETAIL INFORMATION –  
POTENTIAL, FUGITIVE, AND ACTUAL EMISSIONS  
(Optional for unregulated emissions units.)**

**Complete a Subsection F1 for each pollutant identified in Subsection E if applying for an air construction permit or concurrent processing of an air construction permit and a revised or renewal Title V operation permit. Complete for each emissions-limited pollutant identified in Subsection E if applying for an air operation permit.**

**Potential, Estimated Fugitive, and Baseline & Projected Actual Emissions**

|   |  |   |  |
|---|--|---|--|
| 1. Pollutant Emitted:<br>SO2  |  | 2. Total Percent Efficiency of Control:   |  |
| 3. Potential Emissions:<br>4.34 lb/hour                      19.00 tons/year  |  | 4. Synthetically Limited?<br><input type="checkbox"/> Yes <input checked="" type="checkbox"/> No        |  |
| 5. Range of Estimated Fugitive Emissions (as applicable): NA<br>to tons/year  |  |   |  |
| 6. Emission Factor: 10 grain/100 scf<br><br>Reference: FERC limit   |  | 7. Emissions Method Code:<br>2  |  |
| 8.a. Baseline Actual Emissions (if required):<br>NA tons/year   |  | 8.b. Baseline 24-month Period:<br>From:                      To:  |  |
| 9.a. Projected Actual Emissions (if required):<br>NA tons/year  |  | 9.b. Projected Monitoring Period:<br><input type="checkbox"/> 5 years <input type="checkbox"/> 10 years |  |
| 10. Calculation of Emissions:<br><br>$(10 \text{ gr S}/100 \text{ scf})(151,800 \text{ scf/hr})(1 \text{ lb}/7000 \text{ gr}) = 2.17 \text{ lb S/hr}$<br>$(2.17 \text{ lb S/hr})(2 \text{ lb SO}_2/\text{lb S}) = 4.34 \text{ lb SO}_2/\text{hr}$<br>$(4.34 \text{ lb SO}_2/\text{hr})(8760 \text{ hr/yr})(1 \text{ ton}/2000 \text{ lb}) = 19.00 \text{ ton/yr}$ |  |   |  |
| 11. Potential, Fugitive, and Actual Emissions Comment:<br><br>Vendor's data based on ISO conditions with inlet and exhaust losses of 4" of H2O.   |  |   |  |

**EMISSIONS UNIT INFORMATION**

Section [ 1 ] of [ 3 ]

**POLLUTANT DETAIL INFORMATION**

Page [ 4 ] of [ 6 ]

**F2. EMISSIONS UNIT POLLUTANT DETAIL INFORMATION -  
ALLOWABLE EMISSIONS****Complete Subsection F2 if the pollutant identified in Subsection F1 is or would be subject to a numerical emissions limitation.****Allowable Emissions** Allowable Emissions 1 of 1

|  |   |
|--|---|
| 1. Basis for Allowable Emissions Code:<br>RULE   | 2. Future Effective Date of Allowable Emissions: NA                     |
| 3. Allowable Emissions and Units:  | 4. Equivalent Allowable Emissions:<br>4.17 lb/hour      18.27 tons/year |
| 5. Method of Compliance:<br>Initial performance test   |   |
| 6. Allowable Emissions Comment (Description of Operating Method):<br><br>40 CFR 60.4330(a)(2) limits SO2 emissions to 9.06lb/hr. |   |

**Allowable Emissions** Allowable Emissions \_\_ of \_\_

|   |  |
|---|--|
| 1. Basis for Allowable Emissions Code:                            | 2. Future Effective Date of Allowable Emissions:             |
| 3. Allowable Emissions and Units:                                 | 4. Equivalent Allowable Emissions:<br>lb/hour      tons/year |
| 5. Method of Compliance:  |  |
| 6. Allowable Emissions Comment (Description of Operating Method): |  |

**Allowable Emissions** Allowable Emissions \_\_ of \_\_

|   |  |
|---|--|
| 1. Basis for Allowable Emissions Code:                            | 2. Future Effective Date of Allowable Emissions:             |
| 3. Allowable Emissions and Units:                                 | 4. Equivalent Allowable Emissions:<br>lb/hour      tons/year |
| 5. Method of Compliance:  |  |
| 6. Allowable Emissions Comment (Description of Operating Method): |  |

**EMISSIONS UNIT INFORMATION**

Section | 1 | of | 3 |

**POLLUTANT DETAIL INFORMATION**

Page | 5 | of | 6 |

**F1. EMISSIONS UNIT POLLUTANT DETAIL INFORMATION –  
POTENTIAL, FUGITIVE, AND ACTUAL EMISSIONS**

(Optional for unregulated emissions units.)

Complete a Subsection F1 for each pollutant identified in Subsection E if applying for an air construction permit or concurrent processing of an air construction permit and a revised or renewal Title V operation permit. Complete for each emissions-limited pollutant identified in Subsection E if applying for an air operation permit.

**Potential, Estimated Fugitive, and Baseline & Projected Actual Emissions**

|  |  |   |  |
|--|--|---|--|
| 1. Pollutant Emitted:<br>PM  |  | 2. Total Percent Efficiency of Control:   |  |
| 3. Potential Emissions:<br>1.04 lb/hour                      4.56 tons/year  |  | 4. Synthetically Limited?<br><input type="checkbox"/> Yes <input checked="" type="checkbox"/> No        |  |
| 5. Range of Estimated Fugitive Emissions (as applicable): NA<br>to tons/year   |  |   |  |
| 6. Emission Factor: 0.0066 lb/MM Btu<br><br>Reference: Table 3.1-2a, AP-42 4/00  |  | 7. Emissions<br>Method Code:<br>3   |  |
| 8.a. Baseline Actual Emissions (if required):<br>NA tons/year  |  | 8.b. Baseline 24-month Period:<br>From:                      To:  |  |
| 9.a. Projected Actual Emissions (if required):<br>NA tons/year   |  | 9.b. Projected Monitoring Period:<br><input type="checkbox"/> 5 years <input type="checkbox"/> 10 years |  |
| 10. Calculation of Emissions:<br><br>$(0.0066 \text{ lb/MM Btu})(157.89 \text{ MM Btu/hr}) = 1.042 \text{ lb/hr}$<br>$(1.042 \text{ lb/hr})(8760 \text{ hr/yr})(1 \text{ ton}/2000 \text{ lb}) = 4.56 \text{ ton/y}$ |  |   |  |
| 11. Potential, Fugitive, and Actual Emissions Comment:<br><br>Based on vendor's heat input data at ISO conditions with inlet and exhaust losses of 4" of H2O and fuel higher heat value of 1040 Btu/scf              |  |   |  |

**F2. EMISSIONS UNIT POLLUTANT DETAIL INFORMATION -  
 ALLOWABLE EMISSIONS**

**Complete Subsection F2 if the pollutant identified in Subsection F1 is or would be subject to a numerical emissions limitation.**

**Allowable Emissions** Allowable Emissions NA of

|   |  |
|---|--|
| 1. Basis for Allowable Emissions Code:                            | 2. Future Effective Date of Allowable Emissions: NA                          |
| 3. Allowable Emissions and Units:                                 | 4. Equivalent Allowable Emissions:<br>lb/hour                      tons/year |
| 5. Method of Compliance:  |  |
| 6. Allowable Emissions Comment (Description of Operating Method): |  |

**Allowable Emissions** Allowable Emissions \_\_\_ of \_\_\_

|   |  |
|---|--|
| 1. Basis for Allowable Emissions Code:                            | 2. Future Effective Date of Allowable Emissions:                             |
| 3. Allowable Emissions and Units:                                 | 4. Equivalent Allowable Emissions:<br>lb/hour                      tons/year |
| 5. Method of Compliance:  |  |
| 6. Allowable Emissions Comment (Description of Operating Method): |  |

**Allowable Emissions** Allowable Emissions \_\_\_ of \_\_\_

|   |  |
|---|--|
| 1. Basis for Allowable Emissions Code:                            | 2. Future Effective Date of Allowable Emissions:                             |
| 3. Allowable Emissions and Units:                                 | 4. Equivalent Allowable Emissions:<br>lb/hour                      tons/year |
| 5. Method of Compliance:  |  |
| 6. Allowable Emissions Comment (Description of Operating Method): |  |

**EMISSIONS UNIT INFORMATION**

Section [ 1 ] of [ 3 ]

**POLLUTANT DETAIL INFORMATION**

Page [ 6 ] of [ 6 ]

**F1. EMISSIONS UNIT POLLUTANT DETAIL INFORMATION –  
POTENTIAL, FUGITIVE, AND ACTUAL EMISSIONS  
(Optional for unregulated emissions units.)**

**Complete a Subsection F1 for each pollutant identified in Subsection E if applying for an air construction permit or concurrent processing of an air construction permit and a revised or renewal Title V operation permit. Complete for each emissions-limited pollutant identified in Subsection E if applying for an air operation permit.**

**Potential, Estimated Fugitive, and Baseline & Projected Actual Emissions**

|  |  |   |  |
|--|--|---|--|
| 1. Pollutant Emitted:<br>HAPS  |  | 2. Total Percent Efficiency of Control:   |  |
| 3. Potential Emissions:<br>0.16 lb/hour                      0.71 tons/year  |  | 4. Synthetically Limited?<br><input type="checkbox"/> Yes <input checked="" type="checkbox"/> No        |  |
| 5. Range of Estimated Fugitive Emissions (as applicable): NA<br>to tons/year   |  |   |  |
| 6. Emission Factor: 0.001027 lb/MM Btu<br><br>Reference: AP-42, Table 3.1-2a   |  | 7. Emissions<br>Method Code:<br>3   |  |
| 8.a. Baseline Actual Emissions (if required):<br>NA tons/year  |  | 8.b. Baseline 24-month Period:<br>From:                      To:  |  |
| 9.a. Projected Actual Emissions (if required):<br>NA tons/year   |  | 9.b. Projected Monitoring Period:<br><input type="checkbox"/> 5 years <input type="checkbox"/> 10 years |  |
| 10. Calculation of Emissions:<br><br>$(0.001027 \text{ lb/MM Btu})(157.89 \text{ MM Btu/hr}) = 0.162 \text{ lb/hr}$<br>$(0.162 \text{ lb/hr})(8760 \text{ hr/yr})(1 \text{ ton}/2000 \text{ lb}) = 0.71 \text{ ton/y}$ |  |   |  |
| 11. Potential, Fugitive, and Actual Emissions Comment:<br><br>Based on vendor's heat input data at ISO conditions with inlet and exhaust losses of 4" of H2O and fuel higher heat value of 1040 Btu/scf                |  |   |  |



**F2. EMISSIONS UNIT POLLUTANT DETAIL INFORMATION -  
 ALLOWABLE EMISSIONS**

**Complete Subsection F2 if the pollutant identified in Subsection F1 is or would be subject to a numerical emissions limitation.**

**Allowable Emissions** Allowable Emissions NA of

|   |  |
|---|--|
| 1. Basis for Allowable Emissions Code:                            | 2. Future Effective Date of Allowable Emissions: NA                          |
| 3. Allowable Emissions and Units:                                 | 4. Equivalent Allowable Emissions:<br>lb/hour                      tons/year |
| 5. Method of Compliance:  |  |
| 6. Allowable Emissions Comment (Description of Operating Method): |  |

**Allowable Emissions** Allowable Emissions \_\_ of \_\_

|   |  |
|---|--|
| 1. Basis for Allowable Emissions Code:                            | 2. Future Effective Date of Allowable Emissions:                             |
| 3. Allowable Emissions and Units:                                 | 4. Equivalent Allowable Emissions:<br>lb/hour                      tons/year |
| 5. Method of Compliance:  |  |
| 6. Allowable Emissions Comment (Description of Operating Method): |  |

**Allowable Emissions** Allowable Emissions \_\_ of \_\_

|   |  |
|---|--|
| 1. Basis for Allowable Emissions Code:                            | 2. Future Effective Date of Allowable Emissions:                             |
| 3. Allowable Emissions and Units:                                 | 4. Equivalent Allowable Emissions:<br>lb/hour                      tons/year |
| 5. Method of Compliance:  |  |
| 6. Allowable Emissions Comment (Description of Operating Method): |  |

**EMISSIONS UNIT INFORMATION**

Section [ 1 ] of [ 3 ]

**G. VISIBLE EMISSIONS INFORMATION**

Complete Subsection G if this emissions unit is or would be subject to a unit-specific visible emissions limitation.

**Visible Emissions Limitation:** Visible Emissions Limitation 1 of 1

|  |  |
|--|--|
| 1. Visible Emissions Subtype:<br>VE10  | 2. Basis for Allowable Opacity:<br><input checked="" type="checkbox"/> Rule <input type="checkbox"/> Other |
| 3. Allowable Opacity:<br>Normal Conditions: 10 % Exceptional Conditions: %<br>Maximum Period of Excess Opacity Allowed: min/hour |  |
| 3. Method of Compliance:<br>Annual testing with Method 9   |  |
| 4. Visible Emissions Comment:<br><br>Subject to 62-296-320(4)(b) General Visible Emissions Standards.                            |  |

**Visible Emissions Limitation:** Visible Emissions Limitation    of   

|   |   |
|---|---|
| 1. Visible Emissions Subtype:   | 2. Basis for Allowable Opacity:<br><input type="checkbox"/> Rule <input type="checkbox"/> Other |
| 3. Allowable Opacity:<br>Normal Conditions: % Exceptional Conditions: %<br>Maximum Period of Excess Opacity Allowed: min/hour |   |
| 4. Method of Compliance:  |   |
| 5. Visible Emissions Comment:   |   |

**EMISSIONS UNIT INFORMATION**

Section [ 1 ] of [ 3 ]

**H. CONTINUOUS MONITOR INFORMATION**

**Complete Subsection H if this emissions unit is or would be subject to continuous monitoring.**

**Continuous Monitoring System:** Continuous Monitor NA of   

|  |  |
|--|--|
| 1. Parameter Code:   | 2. Pollutant(s):   |
| 3. CMS Requirement:  | <input type="checkbox"/> Rule <input type="checkbox"/> Other |
| 4. Monitor Information...<br>Manufacturer:<br>Model Number: Serial Number: |  |
| 5. Installation Date:  | 6. Performance Specification Test Date:                      |
| 7. Continuous Monitor Comment:   |  |

**Continuous Monitoring System:** Continuous Monitor    of   

|  |  |
|--|--|
| 1. Parameter Code:   | 2. Pollutant(s):   |
| 3. CMS Requirement:  | <input type="checkbox"/> Rule <input type="checkbox"/> Other |
| 4. Monitor Information...<br>Manufacturer:<br>Model Number: Serial Number: |  |
| 5. Installation Date:  | 6. Performance Specification Test Date:                      |
| 7. Continuous Monitor Comment:   |  |

**EMISSIONS UNIT INFORMATION**

Section | 1 | of | 3 |

**I. EMISSIONS UNIT ADDITIONAL INFORMATION**

**Additional Requirements for All Applications, Except as Otherwise Stated**

|   |
|---|
| 1. Process Flow Diagram: (Required for all permit applications, except Title V air operation permit revision applications if this information was submitted to the department within the previous five years and would not be altered as a result of the revision being sought)<br><input checked="" type="checkbox"/> Attached, Document ID: <u>Attach. B</u> <input type="checkbox"/> Previously Submitted, Date _____  |
| 2. Fuel Analysis or Specification: (Required for all permit applications, except Title V air operation permit revision applications if this information was submitted to the department within the previous five years and would not be altered as a result of the revision being sought)<br><input checked="" type="checkbox"/> Attached, Document ID: <u>Attach. G</u> <input type="checkbox"/> Previously Submitted, Date _____  |
| 3. Detailed Description of Control Equipment: (Required for all permit applications, except Title V air operation permit revision applications if this information was submitted to the department within the previous five years and would not be altered as a result of the revision being sought)<br><input type="checkbox"/> Attached, Document ID: <u>NA</u> <input type="checkbox"/> Previously Submitted, Date _____   |
| 4. Procedures for Startup and Shutdown: (Required for all operation permit applications, except Title V air operation permit revision applications if this information was submitted to the department within the previous five years and would not be altered as a result of the revision being sought)<br><input type="checkbox"/> Attached, Document ID: _____ <input type="checkbox"/> Previously Submitted, Date _____<br><input checked="" type="checkbox"/> Not Applicable (construction application)  |
| 5. Operation and Maintenance Plan: (Required for all permit applications, except Title V air operation permit revision applications if this information was submitted to the department within the previous five years and would not be altered as a result of the revision being sought)<br><input type="checkbox"/> Attached, Document ID: _____ <input type="checkbox"/> Previously Submitted, Date _____<br><input checked="" type="checkbox"/> Not Applicable  |
| 6. Compliance Demonstration Reports/Records:<br><input type="checkbox"/> Attached, Document ID: _____<br>Test Date(s)/Pollutant(s) Tested: _____<br><br><input type="checkbox"/> Previously Submitted, Date: _____<br>Test Date(s)/Pollutant(s) Tested: _____<br><br><input type="checkbox"/> To be Submitted, Date (if known): _____<br>Test Date(s)/Pollutant(s) Tested: _____<br><br><input checked="" type="checkbox"/> Not Applicable<br><br>Note: For FESOP applications, all required compliance demonstration records/reports must be submitted at the time of application. For Title V air operation permit applications, all required compliance demonstration reports/records must be submitted at the time of application, or a compliance plan must be submitted at the time of application. |
| 7. Other Information Required by Rule or Statute:<br><input type="checkbox"/> Attached, Document ID: _____ <input checked="" type="checkbox"/> Not Applicable   |

**EMISSIONS UNIT INFORMATION**

Section | 1 | of | 3 |

**I. EMISSIONS UNIT ADDITIONAL INFORMATION (CONTINUED)**

**Additional Requirements for Air Construction Permit Applications**

|  |
|--|
| 1. Control Technology Review and Analysis (Rules 62-212.400(10) and 62-212.500(7), F.A.C.; 40 CFR 63.43(d) and (e)):<br><input checked="" type="checkbox"/> Attached, Document ID: <u>Narr. Sec. 3.0</u> <input type="checkbox"/> Not Applicable |
| 2. Good Engineering Practice Stack Height Analysis (Rules 62-212.400(4)(d) and 62-212.500(4)(f), F.A.C.):<br><input type="checkbox"/> Attached, Document ID: _____ <input checked="" type="checkbox"/> Not Applicable                            |
| 3. Description of Stack Sampling Facilities: (Required for proposed new stack sampling facilities only)<br><input checked="" type="checkbox"/> Attached, Document ID: <u>See Note Below</u> <input type="checkbox"/> Not Applicable              |

**Additional Requirements for Title V Air Operation Permit Applications**

|   |
|---|
| 1. Identification of Applicable Requirements:<br><input type="checkbox"/> Attached, Document ID: <u>NA</u>  |
| 2. Compliance Assurance Monitoring:<br><input type="checkbox"/> Attached, Document ID: _____ <input type="checkbox"/> Not Applicable                    |
| 3. Alternative Methods of Operation:<br><input type="checkbox"/> Attached, Document ID: _____ <input type="checkbox"/> Not Applicable                   |
| 4. Alternative Modes of Operation (Emissions Trading):<br><input type="checkbox"/> Attached, Document ID: _____ <input type="checkbox"/> Not Applicable |

**Additional Requirements Comment**

Supplemental information is provided in the narrative description accompanying these forms.

Specifications for the engine silencers/stacks have not been completed at this time. Final specifications will comply with USEPA and FDEP regulatory requirements.

**EMISSIONS UNIT INFORMATION**

Section | 2| of | 3|

**A. GENERAL EMISSIONS UNIT INFORMATION**

**Title V Air Operation Permit Emissions Unit Classification**

1. Regulated or Unregulated Emissions Unit? (Check one, if applying for an initial, revised or renewal Title V air operation permit. Skip this item if applying for an air construction permit or FESOP only.) NA
- The emissions unit addressed in this Emissions Unit Information Section is a regulated emissions unit.
  - The emissions unit addressed in this Emissions Unit Information Section is an unregulated emissions unit.

**Emissions Unit Description and Status**

1. Type of Emissions Unit Addressed in this Section: (Check one)
- This Emissions Unit Information Section addresses, as a single emissions unit, a single process or production unit, or activity, which produces one or more air pollutants and which has at least one definable emission point (stack or vent).
  - This Emissions Unit Information Section addresses, as a single emissions unit, a group of process or production units and activities which has at least one definable emission point (stack or vent) but may also produce fugitive emissions.
  - This Emissions Unit Information Section addresses, as a single emissions unit, one or more process or production units and activities which produce fugitive emissions only.

1. Description of Emissions Unit Addressed in this Section:

454 bhp natural gas fired, spark ignition, 4-stroke, rich-burn, internal combustion emergency generator engine, FGT Engine No. GEN03

3. Emissions Unit Identification Number: 004

|   |  |                                    |   |
|---|--|------------------------------------|---|
| 4. Emissions Unit Status Code:<br><br>C | 5. Commence Construction Date:<br><br>NA | 6. Initial Startup Date:<br><br>NA | 7. Emissions Unit Major Group SIC Code:<br><br>49 |
|---|--|------------------------------------|---|

8. Federal Program Applicability: (Check all that apply)
- Acid Rain Unit
  - CAIR Unit
  - Hg Budget Unit

9. Package Unit:  
Manufacturer: Generac Model Number: SG300

10. Generator Nameplate Rating: 0.3 MW

11. Emissions Unit Comment:

Fuel will be exclusively natural gas from the FGT's gas pipeline.

**EMISSIONS UNIT INFORMATION**

Section [ 2 ] of [ 3 ]

**Emissions Unit Control Equipment/Method:** Control NA of 1

|  |
|--|
| 1. Control Equipment/Method Description: |
| 2. Control Device or Method Code:        |

**Emissions Unit Control Equipment/Method:** Control \_\_\_ of \_\_\_

|  |
|--|
| 1. Control Equipment/Method Description: |
| 2. Control Device or Method Code:        |

**Emissions Unit Control Equipment/Method:** Control \_\_\_ of \_\_\_

|  |
|--|
| 1. Control Equipment/Method Description: |
| 2. Control Device or Method Code:        |

**Emissions Unit Control Equipment/Method:** Control \_\_\_ of \_\_\_

|  |
|--|
| 1. Control Equipment/Method Description: |
| 2. Control Device or Method Code:        |

**EMISSIONS UNIT INFORMATION**

Section [ 2 ] of [ 3 ]

**B. EMISSIONS UNIT CAPACITY INFORMATION**

**(Optional for unregulated emissions units.)**

**Emissions Unit Operating Capacity and Schedule**

|   |
|---|
| 1. Maximum Process or Throughput Rate: NA   |
| 2. Maximum Production Rate: NA  |
| 3. Maximum Heat Input Rate: 4.26 million Btu/hr   |
| 4. Maximum Incineration Rate: pounds/hr NA<br>tons/day  |
| 5. Requested Maximum Operating Schedule:<br>hours/day days/week<br>weeks/year 100 hours/year  |
| 6. Operating Capacity/Schedule Comment:<br><br>Schedule is based on USEPA defined emergency generator usage of 100 hours per year for maintenance and testing (40 CFR 60.4243(d)). This does not include emergency operation. |



**EMISSIONS UNIT INFORMATION**

Section [ 2 ] of [ 3 ]

**C. EMISSION POINT (STACK/VENT) INFORMATION**

(Optional for unregulated emissions units.)

**Emission Point Description and Type**

|   |  |   |                                |
|---|--|---|--------------------------------|
| 1. Identification of Point on Plot Plan or Flow Diagram: GEN04                                |  | 2. Emission Point Type Code:<br>1   |                                |
| 3. Descriptions of Emission Points Comprising this Emissions Unit for VE Tracking:<br><br>NA  |  |   |                                |
| 4. ID Numbers or Descriptions of Emission Units with this Emission Point in Common:<br><br>NA |  |   |                                |
| 5. Discharge Type Code:<br>V  | 6. Stack Height:<br>7.0 Feet                 |   | 7. Exit Diameter:<br>0.33 feet |
| 8. Exit Temperature:<br>1490 °F   | 9. Actual Volumetric Flow Rate:<br>4335 acfm |   | 10. Water Vapor:<br>NA %       |
| 11. Maximum Dry Standard Flow Rate:<br>NA dscfm   |  | 12. Nonstack Emission Point Height:<br>NA feet  |                                |
| 13. Emission Point UTM Coordinates...<br>Zone: 17 East (km): 353.212<br>North (km): 3193.987  |  | 14. Emission Point Latitude/Longitude...<br>Latitude (DD/MM/SS)<br>Longitude (DD/MM/SS) |                                |
| 15. Emission Point Comment:   |  |   |                                |

**EMISSIONS UNIT INFORMATION**

Section | 2] of | 3]

**D. SEGMENT (PROCESS/FUEL) INFORMATION**

**Segment Description and Rate:** Segment 1 of 1

|   |                                 |  |
|---|---------------------------------|--|
| 1. Segment Description (Process/Fuel Type):<br><br>Natural gas fired 4-stroke, rich-burn engine driving an emergency generator. |                                 |  |
| 2. Source Classification Code (SCC):<br>2-02-002-53   |                                 | 3. SCC Units:<br>million cubic feet burned |
| 4. Maximum Hourly Rate:<br>0.0041   | 5. Maximum Annual Rate:<br>0.41 | 6. Estimated Annual Activity Factor: NA    |
| 7. Maximum % Sulfur:<br>NA  | 8. Maximum % Ash:<br>NA         | 9. Million Btu per SCC Unit:<br>1040       |
| 10. Segment Comment:<br><br>Annual usage based on 100 hours per year operation.   |                                 |  |

**Segment Description and Rate:** Segment    of   

|   |                         |                                      |
|---|-------------------------|--------------------------------------|
| 1. Segment Description (Process/Fuel Type): |                         |                                      |
| 2. Source Classification Code (SCC):        |                         | 3. SCC Units:                        |
| 4. Maximum Hourly Rate:                     | 5. Maximum Annual Rate: | 6. Estimated Annual Activity Factor: |
| 7. Maximum % Sulfur:                        | 8. Maximum % Ash:       | 9. Million Btu per SCC Unit:         |
| 10. Segment Comment:                        |                         |                                      |



**EMISSIONS UNIT INFORMATION**

Section [ 2 ] of [ 3 ]

**POLLUTANT DETAIL INFORMATION**

Page [ 1 ] of [ 6 ]

**F1. EMISSIONS UNIT POLLUTANT DETAIL INFORMATION –  
POTENTIAL, FUGITIVE, AND ACTUAL EMISSIONS  
(Optional for unregulated emissions units.)**

**Complete a Subsection F1 for each pollutant identified in Subsection E if applying for an air construction permit or concurrent processing of an air construction permit and a revised or renewal Title V operation permit. Complete for each emissions-limited pollutant identified in Subsection E if applying for an air operation permit.**

**Potential, Estimated Fugitive, and Baseline & Projected Actual Emissions**

|   |  |   |  |
|---|--|---|--|
| 1. Pollutant Emitted:<br>NOX  |  | 2. Total Percent Efficiency of Control:<br>5.7  |  |
| 3. Potential Emissions:<br>2.00 lb/hour   |  | 1.00 tons/year  | 4. Synthetically Limited?<br><input type="checkbox"/> Yes <input checked="" type="checkbox"/> No |
| 5. Range of Estimated Fugitive Emissions (as applicable): NA<br>to tons/year  |  |   |  |
| 6. Emission Factor: 2.00 g/hp-hr at 5.7% control<br><br>Reference: Vendor data  |  |   | 7. Emissions Method Code:<br>5   |
| 8.a. Baseline Actual Emissions (if required):<br>NA tons/year   |  | 8.b. Baseline 24-month Period:<br>From: To:   |  |
| 9.a. Projected Actual Emissions (if required):<br>NA tons/year  |  | 9.b. Projected Monitoring Period:<br><input type="checkbox"/> 5 years <input type="checkbox"/> 10 years |  |
| 10. Calculation of Emissions:<br><br>(2.00 g/hp-hr)(454 bhp)(1 lb/454 g) = 2.00 lb/hr<br>(2.00 lb/hr)(100 hr/yr)(1 ton/2000 lb) = 0.10 ton/yr                       |  |   |  |
| 11. Potential, Fugitive, and Actual Emissions Comment:<br><br>Calculations based on emergency generator usage of 100 hours per year and minimum control efficiency. |  |   |  |

**EMISSIONS UNIT INFORMATION**

Section | 2 | of | 3 |

**POLLUTANT DETAIL INFORMATION**

Page | 1 | of | 6 |

**F2. EMISSIONS UNIT POLLUTANT DETAIL INFORMATION -  
ALLOWABLE EMISSIONS****Complete Subsection F2 if the pollutant identified in Subsection F1 is or would be subject to a numerical emissions limitation.****Allowable Emissions** Allowable Emissions 1 of 1

|  |  |
|--|--|
| 1. Basis for Allowable Emissions Code:<br>RULE   | 2. Future Effective Date of Allowable Emissions: NA                    |
| 3. Allowable Emissions and Units:<br>2.00 g/hp-hr.   | 4. Equivalent Allowable Emissions:<br>2.00 lb/hour      0.10 tons/year |
| 5. Method of Compliance:<br>Monitor hours of operation   |  |
| 6. Allowable Emissions Comment (Description of Operating Method):<br><br>60.4230 Table 1 limits NOX emissions to 2 g/hhp-hr. |  |

**Allowable Emissions** Allowable Emissions    of   

|   |  |
|---|--|
| 1. Basis for Allowable Emissions Code:                            | 2. Future Effective Date of Allowable Emissions:             |
| 3. Allowable Emissions and Units:                                 | 4. Equivalent Allowable Emissions:<br>lb/hour      tons/year |
| 5. Method of Compliance:  |  |
| 6. Allowable Emissions Comment (Description of Operating Method): |  |

**Allowable Emissions** Allowable Emissions    of   

|   |  |
|---|--|
| 1. Basis for Allowable Emissions Code:                            | 2. Future Effective Date of Allowable Emissions:             |
| 3. Allowable Emissions and Units:                                 | 4. Equivalent Allowable Emissions:<br>lb/hour      tons/year |
| 5. Method of Compliance:  |  |
| 6. Allowable Emissions Comment (Description of Operating Method): |  |

**F1. EMISSIONS UNIT POLLUTANT DETAIL INFORMATION –  
 POTENTIAL, FUGITIVE, AND ACTUAL EMISSIONS**  
 (Optional for unregulated emissions units.)

Complete a Subsection F1 for each pollutant identified in Subsection E if applying for an air construction permit or concurrent processing of an air construction permit and a revised or renewal Title V operation permit. Complete for each emissions-limited pollutant identified in Subsection E if applying for an air operation permit.

**Potential, Estimated Fugitive, and Baseline & Projected Actual Emissions**

|   |  |   |  |
|---|--|---|--|
| 1. Pollutant Emitted:<br>CO   |  | 2. Total Percent Efficiency of Control:<br>96.6   |  |
| 3. Potential Emissions:<br>4.0 lb/hour                      0.40 tons/year  |  | 4. Synthetically Limited?<br><input checked="" type="checkbox"/> Yes <input type="checkbox"/> No        |  |
| 5. Range of Estimated Fugitive Emissions (as applicable): NA<br>to tons/year  |  |   |  |
| 6. Emission Factor: 4.0 g/hp-hr at 96.6% control<br><br>Reference: Vendor data  |  | 7. Emissions Method Code:<br>5  |  |
| 8.a. Baseline Actual Emissions (if required):<br>NA tons/year   |  | 8.b. Baseline 24-month Period:<br>From:                      To:  |  |
| 9.a. Projected Actual Emissions (if required):<br>NA tons/year  |  | 9.b. Projected Monitoring Period:<br><input type="checkbox"/> 5 years <input type="checkbox"/> 10 years |  |
| 10. Calculation of Emissions:<br><br>$(4.00 \text{ g/hp-hr})(454 \text{ bhp})(1 \text{ lb}/454 \text{ g}) = 4.00 \text{ lb/hr}$<br>$(4.00 \text{ lb/hr})(100 \text{ hr/yr})(1 \text{ ton}/2000 \text{ lb}) = 0.40 \text{ ton/yr}$ |  |   |  |
| 11. Potential, Fugitive, and Actual Emissions Comment:<br><br>Calculations based on emergency generator usage of 100 hours per year and minimum control efficiency.   |  |   |  |

**EMISSIONS UNIT INFORMATION**

Section [ 2 ] of [ 3 ]

**POLLUTANT DETAIL INFORMATION**

Page [ 2 ] of [ 6 ]

**F2. EMISSIONS UNIT POLLUTANT DETAIL INFORMATION -  
ALLOWABLE EMISSIONS****Complete Subsection F2 if the pollutant identified in Subsection F1 is or would be subject to a numerical emissions limitation.****Allowable Emissions** Allowable Emissions  1  of  1 

|   |  |
|---|--|
| 1. Basis for Allowable Emissions Code:<br>RULE  | 2. Future Effective Date of Allowable Emissions: NA                    |
| 3. Allowable Emissions and Units:<br>4.00 g/hp-hr.  | 4. Equivalent Allowable Emissions:<br>4.00 lb/hour      0.20 tons/year |
| 5. Method of Compliance:<br>Monitor hours of operation  |  |
| 6. Allowable Emissions Comment (Description of Operating Method):<br><br>60.4230 Table I limits CO emissions to 4 g/hhp-hr. |  |

**Allowable Emissions** Allowable Emissions   of  

|   |  |
|---|--|
| 1. Basis for Allowable Emissions Code:                            | 2. Future Effective Date of Allowable Emissions:             |
| 3. Allowable Emissions and Units:                                 | 4. Equivalent Allowable Emissions:<br>lb/hour      tons/year |
| 5. Method of Compliance:  |  |
| 6. Allowable Emissions Comment (Description of Operating Method): |  |

**Allowable Emissions** Allowable Emissions   of  

|   |  |
|---|--|
| 1. Basis for Allowable Emissions Code:                            | 2. Future Effective Date of Allowable Emissions:             |
| 3. Allowable Emissions and Units:                                 | 4. Equivalent Allowable Emissions:<br>lb/hour      tons/year |
| 5. Method of Compliance:  |  |
| 6. Allowable Emissions Comment (Description of Operating Method): |  |

**EMISSIONS UNIT INFORMATION**

Section [ 2 ] of [ 3 ]

**POLLUTANT DETAIL INFORMATION**

Page [ 3 ] of [ 6 ]

**F1. EMISSIONS UNIT POLLUTANT DETAIL INFORMATION –  
POTENTIAL, FUGITIVE, AND ACTUAL EMISSIONS**

(Optional for unregulated emissions units.)

Complete a Subsection F1 for each pollutant identified in Subsection E if applying for an air construction permit or concurrent processing of an air construction permit and a revised or renewal Title V operation permit. Complete for each emissions-limited pollutant identified in Subsection E if applying for an air operation permit.

**Potential, Estimated Fugitive, and Baseline & Projected Actual Emissions**

|   |  |   |                                |
|---|--|---|--------------------------------|
| 1. Pollutant Emitted:<br>VOC  |  | 2. Total Percent Efficiency of Control:<br>0  |                                |
| 3. Potential Emissions:<br>0.29 lb/hour                      0.01 tons/year   |  | 4. Synthetically Limited?<br><input type="checkbox"/> Yes <input checked="" type="checkbox"/> No        |                                |
| 5. Range of Estimated Fugitive Emissions (as applicable): NA<br>to tons/year  |  |   |                                |
| 6. Emission Factor: 2.91 g/hp-hr THC<br><br>Reference: Vendor data  |  |   | 7. Emissions Method Code:<br>5 |
| 8.a. Baseline Actual Emissions (if required):<br>NA tons/year   |  | 8.b. Baseline 24-month Period:<br>From:                      To:  |                                |
| 9.a. Projected Actual Emissions (if required):<br>NA tons/year  |  | 9.b. Projected Monitoring Period:<br><input type="checkbox"/> 5 years <input type="checkbox"/> 10 years |                                |
| 10. Calculation of Emissions:<br><br>Assume VOC 10% of THC = 0.29 g/hp-hr<br>(0.29 g/hp-hr)(454 bhp)(1 lb/453.6 g) = 0.29 lb/hr<br>(0.29 lb/hr)(100 hr/yr)(1 ton/2000 lb) = 0.01 ton/yr |  |   |                                |
| 11. Potential, Fugitive, and Actual Emissions Comment:<br><br>Calculations based on emergency generator usage of 100 hours per year.  |  |   |                                |



**EMISSIONS UNIT INFORMATION**

Section | 2 | of | 3 |

**POLLUTANT DETAIL INFORMATION**

Page | 3 | of | 6 |

**F2. EMISSIONS UNIT POLLUTANT DETAIL INFORMATION -  
ALLOWABLE EMISSIONS****Complete Subsection F2 if the pollutant identified in Subsection F1 is or would be subject to a numerical emissions limitation.****Allowable Emissions** Allowable Emissions 1 of 1

|  |  |
|--|--|
| 1. Basis for Allowable Emissions Code:<br>RULE   | 2. Future Effective Date of Allowable Emissions: NA                    |
| 3. Allowable Emissions and Units:<br>0.29 g/hhp-hr.  | 4. Equivalent Allowable Emissions:<br>0.29 lb/hour      0.01 tons/year |
| 5. Method of Compliance:<br>Monitor hours of operation   |  |
| 6. Allowable Emissions Comment (Description of Operating Method):<br><br>60.4230 Table 1 limits VOC emissions to 1 g/hhp-hr. |  |

**Allowable Emissions** Allowable Emissions    of   

|   |  |
|---|--|
| 1. Basis for Allowable Emissions Code:                            | 2. Future Effective Date of Allowable Emissions:             |
| 3. Allowable Emissions and Units:                                 | 4. Equivalent Allowable Emissions:<br>lb/hour      tons/year |
| 5. Method of Compliance:  |  |
| 6. Allowable Emissions Comment (Description of Operating Method): |  |

**Allowable Emissions** Allowable Emissions    of   

|   |  |
|---|--|
| 1. Basis for Allowable Emissions Code:                            | 2. Future Effective Date of Allowable Emissions:             |
| 3. Allowable Emissions and Units:                                 | 4. Equivalent Allowable Emissions:<br>lb/hour      tons/year |
| 5. Method of Compliance:  |  |
| 6. Allowable Emissions Comment (Description of Operating Method): |  |

**F1. EMISSIONS UNIT POLLUTANT DETAIL INFORMATION –  
 POTENTIAL, FUGITIVE, AND ACTUAL EMISSIONS**  
 (Optional for unregulated emissions units.)

Complete a Subsection F1 for each pollutant identified in Subsection E if applying for an air construction permit or concurrent processing of an air construction permit and a revised or renewal Title V operation permit. Complete for each emissions-limited pollutant identified in Subsection E if applying for an air operation permit.

**Potential, Estimated Fugitive, and Baseline & Projected Actual Emissions**

|   |  |   |  |
|---|--|---|--|
| 1. Pollutant Emitted:<br>SO2  |  | 2. Total Percent Efficiency of Control:   |  |
| 3. Potential Emissions:<br>0.117 lb/hour                      0.006 tons/year   |  | 4. Synthetically Limited?<br><input checked="" type="checkbox"/> Yes <input type="checkbox"/> No        |  |
| 5. Range of Estimated Fugitive Emissions (as applicable): NA<br>to tons/year  |  |   |  |
| 6. Emission Factor: 10 grains / 100 scf<br><br>Reference: FERC limit  |  | 7. Emissions Method Code:<br>2  |  |
| 8.a. Baseline Actual Emissions (if required):<br>NA tons/year   |  | 8.b. Baseline 24-month Period:<br>From:                      To:  |  |
| 9.a. Projected Actual Emissions (if required):<br>NA tons/year  |  | 9.b. Projected Monitoring Period:<br><input type="checkbox"/> 5 years <input type="checkbox"/> 10 years |  |
| 10. Calculation of Emissions:<br><br>$(10 \text{ gr S}/100 \text{ scf})(4100 \text{ scf/hr})(1 \text{ lb}/7000 \text{ gr}) = 0.059 \text{ lb S/hr}$<br>$(0.059 \text{ lb S/hr})(2 \text{ lb SO}_2/\text{lb S}) = 0.117 \text{ lb SO}_2/\text{hr}$<br>$(0.117 \text{ lb SO}_2/\text{hr})(100 \text{ hr/yr})(1 \text{ ton}/2000 \text{ lb}) = 0.006 \text{ ton/yr}$ |  |   |  |
| 11. Potential, Fugitive, and Actual Emissions Comment:<br><br>Calculations based on emergency generator usage of 100 hours per year.  |  |   |  |

**EMISSIONS UNIT INFORMATION**

Section [ 2 ] of [ 3 ]

**POLLUTANT DETAIL INFORMATION**

Page [ 4 ] of [ 6 ]

**F2. EMISSIONS UNIT POLLUTANT DETAIL INFORMATION -  
ALLOWABLE EMISSIONS****Complete Subsection F2 if the pollutant identified in Subsection F1 is or would be subject to a numerical emissions limitation.****Allowable Emissions** Allowable Emissions NA of

|   |  |
|---|--|
| 1. Basis for Allowable Emissions Code:                            | 2. Future Effective Date of Allowable Emissions: NA                          |
| 3. Allowable Emissions and Units:                                 | 4. Equivalent Allowable Emissions:<br>lb/hour                      tons/year |
| 5. Method of Compliance:  |  |
| 6. Allowable Emissions Comment (Description of Operating Method): |  |

**Allowable Emissions** Allowable Emissions \_\_ of \_\_

|   |  |
|---|--|
| 1. Basis for Allowable Emissions Code:                            | 2. Future Effective Date of Allowable Emissions:                             |
| 3. Allowable Emissions and Units:                                 | 4. Equivalent Allowable Emissions:<br>lb/hour                      tons/year |
| 5. Method of Compliance:  |  |
| 6. Allowable Emissions Comment (Description of Operating Method): |  |

**Allowable Emissions** Allowable Emissions \_\_ of \_\_

|   |  |
|---|--|
| 1. Basis for Allowable Emissions Code:                            | 2. Future Effective Date of Allowable Emissions:                             |
| 3. Allowable Emissions and Units:                                 | 4. Equivalent Allowable Emissions:<br>lb/hour                      tons/year |
| 5. Method of Compliance:  |  |
| 6. Allowable Emissions Comment (Description of Operating Method): |  |

**EMISSIONS UNIT INFORMATION**

Section [ 2 ] of [ 3 ]

**POLLUTANT DETAIL INFORMATION**

Page [ 5 ] of [ 6 ]

**F1. EMISSIONS UNIT POLLUTANT DETAIL INFORMATION –  
POTENTIAL, FUGITIVE, AND ACTUAL EMISSIONS**

(Optional for unregulated emissions units.)

Complete a Subsection F1 for each pollutant identified in Subsection E if applying for an air construction permit or concurrent processing of an air construction permit and a revised or renewal Title V operation permit. Complete for each emissions-limited pollutant identified in Subsection E if applying for an air operation permit.

**Potential, Estimated Fugitive, and Baseline & Projected Actual Emissions**

|   |  |   |  |
|---|--|---|--|
| 1. Pollutant Emitted:<br>PM   |  | 2. Total Percent Efficiency of Control:   |  |
| 3. Potential Emissions:<br>0.083 lb/hour                      0.004 tons/year   |  | 4. Synthetically Limited?<br><input checked="" type="checkbox"/> Yes <input type="checkbox"/> No        |  |
| 5. Range of Estimated Fugitive Emissions (as applicable): NA<br>to tons/year  |  |   |  |
| 6. Emission Factor: 0.01941 lb/MM Btu<br><br>Reference: Table 3.2-3, AP-42 7/00   |  | 7. Emissions Method Code:<br>3  |  |
| 8.a. Baseline Actual Emissions (if required):<br>NA tons/year   |  | 8.b. Baseline 24-month Period:<br>From:                      To:  |  |
| 9.a. Projected Actual Emissions (if required):<br>NA tons/year  |  | 9.b. Projected Monitoring Period:<br><input type="checkbox"/> 5 years <input type="checkbox"/> 10 years |  |
| 10. Calculation of Emissions:<br><br>$(0.01941 \text{ lb/MM Btu})(4.26 \text{ MM Btu/hr}) = 0.083 \text{ lb/hr}$<br>$(0.083 \text{ lb/hr})(100 \text{ hr/yr})(1 \text{ ton}/2000 \text{ lb}) = 0.004 \text{ ton/y}$ |  |   |  |
| 11. Potential, Fugitive, and Actual Emissions Comment:<br><br>Calculations based on emergency generator usage of 100 hours per year.  |  |   |  |

**EMISSIONS UNIT INFORMATION**

Section [ 2 ] of [ 3 ]

**POLLUTANT DETAIL INFORMATION**

Page [ 5 ] of [ 6 ]

**F2. EMISSIONS UNIT POLLUTANT DETAIL INFORMATION -  
ALLOWABLE EMISSIONS****Complete Subsection F2 if the pollutant identified in Subsection F1 is or would be subject to a numerical emissions limitation.****Allowable Emissions** Allowable Emissions NA of

|   |  |
|---|--|
| 1. Basis for Allowable Emissions Code:                            | 2. Future Effective Date of Allowable Emissions: NA                          |
| 3. Allowable Emissions and Units:                                 | 4. Equivalent Allowable Emissions:<br>lb/hour                      tons/year |
| 5. Method of Compliance:  |  |
| 6. Allowable Emissions Comment (Description of Operating Method): |  |

**Allowable Emissions** Allowable Emissions \_\_ of \_\_

|   |  |
|---|--|
| 1. Basis for Allowable Emissions Code:                            | 2. Future Effective Date of Allowable Emissions:                             |
| 3. Allowable Emissions and Units:                                 | 4. Equivalent Allowable Emissions:<br>lb/hour                      tons/year |
| 5. Method of Compliance:  |  |
| 6. Allowable Emissions Comment (Description of Operating Method): |  |

**Allowable Emissions** Allowable Emissions \_\_ of \_\_

|   |  |
|---|--|
| 1. Basis for Allowable Emissions Code:                            | 2. Future Effective Date of Allowable Emissions:                             |
| 3. Allowable Emissions and Units:                                 | 4. Equivalent Allowable Emissions:<br>lb/hour                      tons/year |
| 5. Method of Compliance:  |  |
| 6. Allowable Emissions Comment (Description of Operating Method): |  |

**EMISSIONS UNIT INFORMATION**

Section | 2 | of | 3 |

**POLLUTANT DETAIL INFORMATION**

Page | 6 | of | 6 |

**F1. EMISSIONS UNIT POLLUTANT DETAIL INFORMATION –  
POTENTIAL, FUGITIVE, AND ACTUAL EMISSIONS**

(Optional for unregulated emissions units.)

Complete a Subsection F1 for each pollutant identified in Subsection E if applying for an air construction permit or concurrent processing of an air construction permit and a revised or renewal Title V operation permit. Complete for each emissions-limited pollutant identified in Subsection E if applying for an air operation permit.

**Potential, Estimated Fugitive, and Baseline & Projected Actual Emissions**

|   |  |   |  |
|---|--|---|--|
| 1. Pollutant Emitted:<br>HAPS   |  | 2. Total Percent Efficiency of Control:   |  |
| 3. Potential Emissions:<br>0.10 lb/hour                      0.005 tons/year  |  | 4. Synthetically Limited?<br><input checked="" type="checkbox"/> Yes <input type="checkbox"/> No        |  |
| 5. Range of Estimated Fugitive Emissions (as applicable): NA<br>to tons/year  |  |   |  |
| 6. Emission Factor: 0.0234 lb/MM Btu<br><br>Reference: AP-42, Table 3.2-3   |  | 7. Emissions Method Code:<br>3  |  |
| 8.a. Baseline Actual Emissions (if required):<br>NA tons/year   |  | 8.b. Baseline 24-month Period:<br>From:                      To:  |  |
| 9.a. Projected Actual Emissions (if required):<br>NA tons/year  |  | 9.b. Projected Monitoring Period:<br><input type="checkbox"/> 5 years <input type="checkbox"/> 10 years |  |
| 10. Calculation of Emissions:<br><br>$(0.0234 \text{ lb/MM Btu})(4.26 \text{ MM Btu/hr}) = 0.10 \text{ lb/hr}$<br>$(0.10 \text{ lb/hr})(8760 \text{ hr/yr})(1 \text{ ton}/2000 \text{ lb}) = 0.005 \text{ ton/y}$ |  |   |  |
| 11. Potential, Fugitive, and Actual Emissions Comment:<br><br>Calculations based on emergency generator usage of 100 hours per year.  |  |   |  |

**F2. EMISSIONS UNIT POLLUTANT DETAIL INFORMATION -  
 ALLOWABLE EMISSIONS**

**Complete Subsection F2 if the pollutant identified in Subsection F1 is or would be subject to a numerical emissions limitation.**

**Allowable Emissions** Allowable Emissions NA of

|   |  |
|---|--|
| 1. Basis for Allowable Emissions Code:                            | 2. Future Effective Date of Allowable Emissions: NA                          |
| 3. Allowable Emissions and Units:                                 | 4. Equivalent Allowable Emissions:<br>lb/hour                      tons/year |
| 5. Method of Compliance:  |  |
| 6. Allowable Emissions Comment (Description of Operating Method): |  |

**Allowable Emissions** Allowable Emissions    of   

|   |  |
|---|--|
| 1. Basis for Allowable Emissions Code:                            | 2. Future Effective Date of Allowable Emissions:                             |
| 3. Allowable Emissions and Units:                                 | 4. Equivalent Allowable Emissions:<br>lb/hour                      tons/year |
| 5. Method of Compliance:  |  |
| 6. Allowable Emissions Comment (Description of Operating Method): |  |

**Allowable Emissions** Allowable Emissions    of   

|   |  |
|---|--|
| 1. Basis for Allowable Emissions Code:                            | 2. Future Effective Date of Allowable Emissions:                             |
| 3. Allowable Emissions and Units:                                 | 4. Equivalent Allowable Emissions:<br>lb/hour                      tons/year |
| 5. Method of Compliance:  |  |
| 6. Allowable Emissions Comment (Description of Operating Method): |  |

**EMISSIONS UNIT INFORMATION**

Section | 2 | of | 3 |

**G. VISIBLE EMISSIONS INFORMATION**

**Complete Subsection G if this emissions unit is or would be subject to a unit-specific visible emissions limitation.**

**Visible Emissions Limitation:** Visible Emissions Limitation NA of

|   |   |
|---|---|
| 1. Visible Emissions Subtype:   | 2. Basis for Allowable Opacity:<br><input type="checkbox"/> Rule <input type="checkbox"/> Other |
| 3. Allowable Opacity:<br>Normal Conditions:                      %      Exceptional Conditions:                      %<br>Maximum Period of Excess Opacity Allowed:                      min/hour |   |
| 2. Method of Compliance:  |   |
| 3. Visible Emissions Comment:   |   |

**Visible Emissions Limitation:** Visible Emissions Limitation    of   

|   |   |
|---|---|
| 1. Visible Emissions Subtype:   | 2. Basis for Allowable Opacity:<br><input type="checkbox"/> Rule <input type="checkbox"/> Other |
| 3. Allowable Opacity:<br>Normal Conditions:                      %      Exceptional Conditions:                      %<br>Maximum Period of Excess Opacity Allowed:                      min/hour |   |
| 4. Method of Compliance:  |   |
| 5. Visible Emissions Comment:   |   |



**EMISSIONS UNIT INFORMATION**

Section | 2 | of | 3 |

**H. CONTINUOUS MONITOR INFORMATION**

Complete Subsection H if this emissions unit is or would be subject to continuous monitoring.

**Continuous Monitoring System:** Continuous Monitor NA of   

|  |  |
|--|--|
| 1. Parameter Code:   | 2. Pollutant(s):   |
| 3. CMS Requirement:  | <input type="checkbox"/> Rule <input type="checkbox"/> Other |
| 4. Monitor Information...<br>Manufacturer:<br>Model Number: Serial Number: |  |
| 5. Installation Date:  | 6. Performance Specification Test Date:                      |
| 7. Continuous Monitor Comment:   |  |

**Continuous Monitoring System:** Continuous Monitor    of   

|  |  |
|--|--|
| 1. Parameter Code:   | 2. Pollutant(s):   |
| 3. CMS Requirement:  | <input type="checkbox"/> Rule <input type="checkbox"/> Other |
| 4. Monitor Information...<br>Manufacturer:<br>Model Number: Serial Number: |  |
| 5. Installation Date:  | 6. Performance Specification Test Date:                      |
| 7. Continuous Monitor Comment:   |  |

**EMISSIONS UNIT INFORMATION**

Section | 2 | of | 3 |

**I. EMISSIONS UNIT ADDITIONAL INFORMATION**

**Additional Requirements for All Applications, Except as Otherwise Stated**

|   |
|---|
| 1. Process Flow Diagram: (Required for all permit applications, except Title V air operation permit revision applications if this information was submitted to the department within the previous five years and would not be altered as a result of the revision being sought)<br><input checked="" type="checkbox"/> Attached, Document ID: <u>Attach. B</u> <input type="checkbox"/> Previously Submitted, Date _____  |
| 2. Fuel Analysis or Specification: (Required for all permit applications, except Title V air operation permit revision applications if this information was submitted to the department within the previous five years and would not be altered as a result of the revision being sought)<br><input checked="" type="checkbox"/> Attached, Document ID: <u>Attach. G</u> <input type="checkbox"/> Previously Submitted, Date _____  |
| 3. Detailed Description of Control Equipment: (Required for all permit applications, except Title V air operation permit revision applications if this information was submitted to the department within the previous five years and would not be altered as a result of the revision being sought)<br><input checked="" type="checkbox"/> Attached, Document ID: <u>See note below</u> <input type="checkbox"/> Previously Submitted, Date _____  |
| 4. Procedures for Startup and Shutdown: (Required for all operation permit applications, except Title V air operation permit revision applications if this information was submitted to the department within the previous five years and would not be altered as a result of the revision being sought)<br><input type="checkbox"/> Attached, Document ID: _____ <input type="checkbox"/> Previously Submitted, Date _____<br><input checked="" type="checkbox"/> Not Applicable (construction application)  |
| 5. Operation and Maintenance Plan: (Required for all permit applications, except Title V air operation permit revision applications if this information was submitted to the department within the previous five years and would not be altered as a result of the revision being sought)<br><input type="checkbox"/> Attached, Document ID: _____ <input type="checkbox"/> Previously Submitted, Date _____<br><input checked="" type="checkbox"/> Not Applicable  |
| 6. Compliance Demonstration Reports/Records:<br><input type="checkbox"/> Attached, Document ID: _____<br>Test Date(s)/Pollutant(s) Tested: _____<br><br><input type="checkbox"/> Previously Submitted, Date: _____<br>Test Date(s)/Pollutant(s) Tested: _____<br><br><input type="checkbox"/> To be Submitted, Date (if known): _____<br>Test Date(s)/Pollutant(s) Tested: _____<br><br><input checked="" type="checkbox"/> Not Applicable<br><br>Note: For FESOP applications, all required compliance demonstration records/reports must be submitted at the time of application. For Title V air operation permit applications, all required compliance demonstration reports/records must be submitted at the time of application, or a compliance plan must be submitted at the time of application. |
| 7. Other Information Required by Rule or Statute:<br><input type="checkbox"/> Attached, Document ID: _____ <input checked="" type="checkbox"/> Not Applicable   |

**EMISSIONS UNIT INFORMATION**

Section [ 2 ] of [ 3 ]

**I. EMISSIONS UNIT ADDITIONAL INFORMATION (CONTINUED)**

**Additional Requirements for Air Construction Permit Applications**

|  |
|--|
| 1. Control Technology Review and Analysis (Rules 62-212.400(10) and 62-212.500(7), F.A.C.; 40 CFR 63.43(d) and (e)):<br><input checked="" type="checkbox"/> Attached, Document ID: <i>Narr. Sec. 3.0</i> <input type="checkbox"/> Not Applicable |
| 2. Good Engineering Practice Stack Height Analysis (Rules 62-212.400(4)(d) and 62-212.500(4)(f), F.A.C.):<br><input type="checkbox"/> Attached, Document ID: _____ <input checked="" type="checkbox"/> Not Applicable                            |
| 3. Description of Stack Sampling Facilities: (Required for proposed new stack sampling facilities only)<br><input checked="" type="checkbox"/> Attached, Document ID: <i>See note below</i> <input type="checkbox"/> Not Applicable              |

**Additional Requirements for Title V Air Operation Permit Applications**

|   |
|---|
| 1. Identification of Applicable Requirements:<br><input type="checkbox"/> Attached, Document ID: <i>NA</i>  |
| 2. Compliance Assurance Monitoring:<br><input type="checkbox"/> Attached, Document ID: _____ <input type="checkbox"/> Not Applicable                    |
| 3. Alternative Methods of Operation:<br><input type="checkbox"/> Attached, Document ID: _____ <input type="checkbox"/> Not Applicable                   |
| 4. Alternative Modes of Operation (Emissions Trading):<br><input type="checkbox"/> Attached, Document ID: _____ <input type="checkbox"/> Not Applicable |

**Additional Requirements Comment**

Supplemental information is provided in the narrative description accompanying these forms.

The manufacturer has not completed design specifications and has not provided final emission rates at this time. Emissions will comply with applicable 40 CFR Subpart JJJJ requirements.

Specifications for the sampling facilities have not been completed at this time. Final specifications will comply with USEPA and FDEP regulatory requirements.



**EMISSIONS UNIT INFORMATION**

Section [ 3 ] of [ 3 ]

**Emissions Unit Control Equipment/Method:** Control NA of   

1. Control Equipment/Method Description:

2. Control Device or Method Code:

**Emissions Unit Control Equipment/Method:** Control    of   

1. Control Equipment/Method Description:

2. Control Device or Method Code:

**Emissions Unit Control Equipment/Method:** Control    of   

1. Control Equipment/Method Description:

2. Control Device or Method Code:

**Emissions Unit Control Equipment/Method:** Control    of   

1. Control Equipment/Method Description:

2. Control Device or Method Code:



**EMISSIONS UNIT INFORMATION**

Section [ 3 ] of [ 3 ]

**C. EMISSION POINT (STACK/VENT) INFORMATION****(Optional for unregulated emissions units.)****Emission Point Description and Type**

|   |  |  |   |                                |  |
|---|--|--|---|--------------------------------|--|
| 1. Identification of Point on Plot Plan or Flow Diagram: GEN04                                |  | 2. Emission Point Type Code:<br>1            |   |                                |  |
| 3. Descriptions of Emission Points Comprising this Emissions Unit for VE Tracking:<br><br>NA  |  |  |   |                                |  |
| 4. ID Numbers or Descriptions of Emission Units with this Emission Point in Common:<br><br>NA |  |  |   |                                |  |
| 5. Discharge Type Code:<br>V  |  | 6. Stack Height:<br>7.0 Feet                 |   | 7. Exit Diameter:<br>0.33 feet |  |
| 8. Exit Temperature:<br>1490 °F   |  | 9. Actual Volumetric Flow Rate:<br>4335 acfm |   | 10. Water Vapor:<br>NA %       |  |
| 11. Maximum Dry Standard Flow Rate:<br>NA dscfm   |  |  | 12. Nonstack Emission Point Height:<br>NA feet  |                                |  |
| 13. Emission Point UTM Coordinates...<br>Zone: 17 East (km): 353.212<br>North (km): 3193.987  |  |  | 14. Emission Point Latitude/Longitude...<br>Latitude (DD/MM/SS)<br>Longitude (DD/MM/SS) |                                |  |
| 15. Emission Point Comment:   |  |  |   |                                |  |

**EMISSIONS UNIT INFORMATION**

Section [ 3 ] of [ 3 ]

**D. SEGMENT (PROCESS/FUEL) INFORMATION**

**Segment Description and Rate:** Segment  1  of  1

|   |                                 |  |
|---|---------------------------------|--|
| 1. Segment Description (Process/Fuel Type):<br><br>Natural gas fired 4-stroke, rich-burn engine driving an emergency generator. |                                 |  |
| 2. Source Classification Code (SCC):<br>2-02-002-53   |                                 | 3. SCC Units:<br>million cubic feet burned |
| 4. Maximum Hourly Rate:<br>0.0041   | 5. Maximum Annual Rate:<br>0.41 | 6. Estimated Annual Activity Factor:<br>NA |
| 7. Maximum % Sulfur:<br>NA  | 8. Maximum % Ash:<br>NA         | 9. Million Btu per SCC Unit:<br>1040       |
| 10. Segment Comment:<br><br>Annual usage based on 100 hours per year operation.   |                                 |  |

**Segment Description and Rate:** Segment   of

|   |                         |                                      |
|---|-------------------------|--------------------------------------|
| 1. Segment Description (Process/Fuel Type):<br><br> |                         |                                      |
| 2. Source Classification Code (SCC):                |                         | 3. SCC Units:                        |
| 4. Maximum Hourly Rate:                             | 5. Maximum Annual Rate: | 6. Estimated Annual Activity Factor: |
| 7. Maximum % Sulfur:                                | 8. Maximum % Ash:       | 9. Million Btu per SCC Unit:         |
| 10. Segment Comment:<br><br>                        |                         |                                      |





**EMISSIONS UNIT INFORMATION**

Section [ 3 ] of [ 3 ]

**POLLUTANT DETAIL INFORMATION**

Page [ 1 ] of [ 6 ]

**F1. EMISSIONS UNIT POLLUTANT DETAIL INFORMATION –  
POTENTIAL, FUGITIVE, AND ACTUAL EMISSIONS  
(Optional for unregulated emissions units.)**

**Complete a Subsection F1 for each pollutant identified in Subsection E if applying for an air construction permit or concurrent processing of an air construction permit and a revised or renewal Title V operation permit. Complete for each emissions-limited pollutant identified in Subsection E if applying for an air operation permit.**

**Potential, Estimated Fugitive, and Baseline & Projected Actual Emissions**

|  |  |   |  |
|--|--|---|--|
| 1. Pollutant Emitted:<br>NOX   |  | 2. Total Percent Efficiency of Control:<br>5.7  |  |
| 3. Potential Emissions:<br>2.00 lb/hour                      0.20 tons/year  |  | 4. Synthetically Limited?<br><input type="checkbox"/> Yes <input checked="" type="checkbox"/> No        |  |
| 5. Range of Estimated Fugitive Emissions (as applicable): NA<br>to tons/year   |  |   |  |
| 6. Emission Factor: 2.00 g/hp-hr at 5.7% control<br><br>Reference: Vendor data   |  | 7. Emissions Method Code:<br>5  |  |
| 8.a. Baseline Actual Emissions (if required):<br>NA tons/year  |  | 8.b. Baseline 24-month Period:<br>From:                      To:  |  |
| 9.a. Projected Actual Emissions (if required):<br>NA tons/year   |  | 9.b. Projected Monitoring Period:<br><input type="checkbox"/> 5 years <input type="checkbox"/> 10 years |  |
| 10. Calculation of Emissions:<br><br>$(2.00 \text{ g/hp-hr})(454 \text{ bhp})(1 \text{ lb}/454 \text{ g}) = 2.00 \text{ lb/hr}$ $(2.00 \text{ lb/hr})(100 \text{ hr/yr})(1 \text{ ton}/2000 \text{ lb}) = 0.10 \text{ ton/yr}$ |  |   |  |
| 11. Potential, Fugitive, and Actual Emissions Comment:<br><br>Calculations based on emergency generator usage of 100 hours per year and minimum control efficiency.  |  |   |  |

**EMISSIONS UNIT INFORMATION**

Section [ 3 ] of [ 3 ]

**POLLUTANT DETAIL INFORMATION**

Page [ 1 ] of [ 6 ]

**F2. EMISSIONS UNIT POLLUTANT DETAIL INFORMATION -  
ALLOWABLE EMISSIONS****Complete Subsection F2 if the pollutant identified in Subsection F1 is or would be subject to a numerical emissions limitation.****Allowable Emissions** Allowable Emissions 1 of 1

|  |  |
|--|--|
| 1. Basis for Allowable Emissions Code:<br>RULE   | 2. Future Effective Date of Allowable Emissions: NA                    |
| 3. Allowable Emissions and Units:<br>2.0 g/hp-hr.  | 4. Equivalent Allowable Emissions:<br>2.00 lb/hour      0.10 tons/year |
| 5. Method of Compliance:<br>Monitor hours of operation   |  |
| 6. Allowable Emissions Comment (Description of Operating Method):<br><br>60.4230 Table I limits NOX emissions to 2 g/hhp-hr. |  |

**Allowable Emissions** Allowable Emissions    of   

|   |  |
|---|--|
| 1. Basis for Allowable Emissions Code:                            | 2. Future Effective Date of Allowable Emissions:             |
| 3. Allowable Emissions and Units:                                 | 4. Equivalent Allowable Emissions:<br>lb/hour      tons/year |
| 5. Method of Compliance:  |  |
| 6. Allowable Emissions Comment (Description of Operating Method): |  |

**Allowable Emissions** Allowable Emissions    of   

|   |  |
|---|--|
| 1. Basis for Allowable Emissions Code:                            | 2. Future Effective Date of Allowable Emissions:             |
| 3. Allowable Emissions and Units:                                 | 4. Equivalent Allowable Emissions:<br>lb/hour      tons/year |
| 5. Method of Compliance:  |  |
| 6. Allowable Emissions Comment (Description of Operating Method): |  |

**EMISSIONS UNIT INFORMATION**

Section [ 3 ] of [ 3 ]

**POLLUTANT DETAIL INFORMATION**

Page [ 2 ] of [ 6 ]

**F1. EMISSIONS UNIT POLLUTANT DETAIL INFORMATION –  
POTENTIAL, FUGITIVE, AND ACTUAL EMISSIONS  
(Optional for unregulated emissions units.)**

**Complete a Subsection F1 for each pollutant identified in Subsection E if applying for an air construction permit or concurrent processing of an air construction permit and a revised or renewal Title V operation permit. Complete for each emissions-limited pollutant identified in Subsection E if applying for an air operation permit.**

**Potential, Estimated Fugitive, and Baseline & Projected Actual Emissions**

|   |  |   |                                |
|---|--|---|--------------------------------|
| 1. Pollutant Emitted:<br>CO   |  | 2. Total Percent Efficiency of Control:<br>96.6   |                                |
| 3. Potential Emissions:<br>4.00 lb/hour                      0.20 tons/year   |  | 4. Synthetically Limited?<br><input checked="" type="checkbox"/> Yes <input type="checkbox"/> No        |                                |
| 5. Range of Estimated Fugitive Emissions (as applicable): NA<br>to tons/year  |  |   |                                |
| 6. Emission Factor: 4.0 g/hp-hr at 96.6% control<br><br>Reference: Vendor data  |  |   | 7. Emissions Method Code:<br>5 |
| 8.a. Baseline Actual Emissions (if required):<br>NA tons/year   |  | 8.b. Baseline 24-month Period:<br>From:                      To:  |                                |
| 9.a. Projected Actual Emissions (if required):<br>NA tons/year  |  | 9.b. Projected Monitoring Period:<br><input type="checkbox"/> 5 years <input type="checkbox"/> 10 years |                                |
| 10. Calculation of Emissions:<br><br>4.00 g/hp-hr)(454 bhp)(1 lb/454 g) = 4.00 lb/hr<br>(4.00 lb/hr)(100 hr/yr)(1 ton/2000 lb) = 0.40 ton/yr                        |  |   |                                |
| 11. Potential, Fugitive, and Actual Emissions Comment:<br><br>Calculations based on emergency generator usage of 100 hours per year and minimum control efficiency. |  |   |                                |

**EMISSIONS UNIT INFORMATION**

Section [ 3 ] of [ 3 ]

**POLLUTANT DETAIL INFORMATION**

Page [ 2 ] of [ 6 ]

**F2. EMISSIONS UNIT POLLUTANT DETAIL INFORMATION -  
ALLOWABLE EMISSIONS****Complete Subsection F2 if the pollutant identified in Subsection F1 is or would be subject to a numerical emissions limitation.****Allowable Emissions** Allowable Emissions  1  of  1 

|   |  |
|---|--|
| 1. Basis for Allowable Emissions Code:<br>RULE  | 2. Future Effective Date of Allowable Emissions: NA                    |
| 3. Allowable Emissions and Units:<br>4.00 g/hp-hr.  | 4. Equivalent Allowable Emissions:<br>4.00 lb/hour      0.20 tons/year |
| 5. Method of Compliance:<br>Monitor hours of operation  |  |
| 6. Allowable Emissions Comment (Description of Operating Method):<br><br>60.4230 Table 1 limits CO emissions to 4 g/hhp-hr. |  |

**Allowable Emissions** Allowable Emissions   of  

|   |  |
|---|--|
| 1. Basis for Allowable Emissions Code:                            | 2. Future Effective Date of Allowable Emissions:             |
| 3. Allowable Emissions and Units:                                 | 4. Equivalent Allowable Emissions:<br>lb/hour      tons/year |
| 5. Method of Compliance:  |  |
| 6. Allowable Emissions Comment (Description of Operating Method): |  |

**Allowable Emissions** Allowable Emissions   of  

|   |  |
|---|--|
| 1. Basis for Allowable Emissions Code:                            | 2. Future Effective Date of Allowable Emissions:             |
| 3. Allowable Emissions and Units:                                 | 4. Equivalent Allowable Emissions:<br>lb/hour      tons/year |
| 5. Method of Compliance:  |  |
| 6. Allowable Emissions Comment (Description of Operating Method): |  |

**EMISSIONS UNIT INFORMATION**

Section | 3 | of | 3 |

**POLLUTANT DETAIL INFORMATION**

Page | 3 | of | 6 |

**F1. EMISSIONS UNIT POLLUTANT DETAIL INFORMATION –  
POTENTIAL, FUGITIVE, AND ACTUAL EMISSIONS  
(Optional for unregulated emissions units.)**

**Complete a Subsection F1 for each pollutant identified in Subsection E if applying for an air construction permit or concurrent processing of an air construction permit and a revised or renewal Title V operation permit. Complete for each emissions-limited pollutant identified in Subsection E if applying for an air operation permit.**

**Potential, Estimated Fugitive, and Baseline & Projected Actual Emissions**

|   |  |   |  |
|---|--|---|--|
| 1. Pollutant Emitted:<br>VOC  |  | 2. Total Percent Efficiency of Control:<br>0  |  |
| 3. Potential Emissions:<br>0.29 lb/hour                      0.01 tons/year   |  | 4. Synthetically Limited?<br><input type="checkbox"/> Yes <input checked="" type="checkbox"/> No        |  |
| 5. Range of Estimated Fugitive Emissions (as applicable): NA<br>to tons/year  |  |   |  |
| 6. Emission Factor: 2.91 g/hp-hr THC<br><br>Reference: Vendor data  |  | 7. Emissions<br>Method Code:<br>5   |  |
| 8.a. Baseline Actual Emissions (if required):<br>NA tons/year   |  | 8.b. Baseline 24-month Period:<br>From:                      To:  |  |
| 9.a. Projected Actual Emissions (if required):<br>NA tons/year  |  | 9.b. Projected Monitoring Period:<br><input type="checkbox"/> 5 years <input type="checkbox"/> 10 years |  |
| 10. Calculation of Emissions:<br><br>Assume VOC 10% of THC = 0.29 g/hp-hr<br>(0.29 g/hp-hr)(454 bhp)(1 lb/453.6 g) = 0.29 lb/hr<br>(0.29 lb/hr)(100 hr/yr)(1 ton/2000 lb) = 0.01 ton/yr |  |   |  |
| 11. Potential, Fugitive, and Actual Emissions Comment:<br><br>Calculations based on emergency generator usage of 100 hours per year.  |  |   |  |

**EMISSIONS UNIT INFORMATION**

Section [ 3 ] of [ 3 ]

**POLLUTANT DETAIL INFORMATION**

Page [ 3 ] of [ 6 ]

**F2. EMISSIONS UNIT POLLUTANT DETAIL INFORMATION -  
ALLOWABLE EMISSIONS****Complete Subsection F2 if the pollutant identified in Subsection F1 is or would be subject to a numerical emissions limitation.****Allowable Emissions** Allowable Emissions 1 of 1

|  |  |
|--|--|
| 1. Basis for Allowable Emissions Code:<br>RULE   | 2. Future Effective Date of Allowable Emissions: NA                    |
| 3. Allowable Emissions and Units:<br>0.29 g/hhp-hr.  | 4. Equivalent Allowable Emissions:<br>0.29 lb/hour      0.01 tons/year |
| 5. Method of Compliance:<br>Monitor hours of operation   |  |
| 6. Allowable Emissions Comment (Description of Operating Method):<br><br>60.4230 Table 1 limits VOC emissions to 1 g/hhp-hr. |  |

**Allowable Emissions** Allowable Emissions    of   

|   |  |
|---|--|
| 1. Basis for Allowable Emissions Code:                            | 2. Future Effective Date of Allowable Emissions:             |
| 3. Allowable Emissions and Units:                                 | 4. Equivalent Allowable Emissions:<br>lb/hour      tons/year |
| 5. Method of Compliance:  |  |
| 6. Allowable Emissions Comment (Description of Operating Method): |  |

**Allowable Emissions** Allowable Emissions    of   

|   |  |
|---|--|
| 1. Basis for Allowable Emissions Code:                            | 2. Future Effective Date of Allowable Emissions:             |
| 3. Allowable Emissions and Units:                                 | 4. Equivalent Allowable Emissions:<br>lb/hour      tons/year |
| 5. Method of Compliance:  |  |
| 6. Allowable Emissions Comment (Description of Operating Method): |  |

**EMISSIONS UNIT INFORMATION**

Section [ 3 ] of [ 3 ]

**POLLUTANT DETAIL INFORMATION**

Page [ 4 ] of [ 6 ]

**F1. EMISSIONS UNIT POLLUTANT DETAIL INFORMATION –  
POTENTIAL, FUGITIVE, AND ACTUAL EMISSIONS  
(Optional for unregulated emissions units.)**

**Complete a Subsection F1 for each pollutant identified in Subsection E if applying for an air construction permit or concurrent processing of an air construction permit and a revised or renewal Title V operation permit. Complete for each emissions-limited pollutant identified in Subsection E if applying for an air operation permit.**

**Potential, Estimated Fugitive, and Baseline & Projected Actual Emissions**

|   |  |   |  |
|---|--|---|--|
| 1. Pollutant Emitted:<br>SO2  |  | 2. Total Percent Efficiency of Control:   |  |
| 3. Potential Emissions:<br>0.117 lb/hour                      0.006 tons/year   |  | 4. Synthetically Limited?<br><input checked="" type="checkbox"/> Yes <input type="checkbox"/> No        |  |
| 5. Range of Estimated Fugitive Emissions (as applicable): NA<br>to tons/year  |  |   |  |
| 6. Emission Factor: 10 grains / 100 scf<br><br>Reference: FERC limit  |  | 7. Emissions Method Code:<br>2  |  |
| 8.a. Baseline Actual Emissions (if required):<br>NA tons/year   |  | 8.b. Baseline 24-month Period:<br>From:                      To:  |  |
| 9.a. Projected Actual Emissions (if required):<br>NA tons/year  |  | 9.b. Projected Monitoring Period:<br><input type="checkbox"/> 5 years <input type="checkbox"/> 10 years |  |
| 10. Calculation of Emissions:<br><br>$(10 \text{ gr S}/100 \text{ scf})(4100 \text{ scf/hr})(1 \text{ lb}/7000 \text{ gr}) = 0.059 \text{ lb S/hr}$<br>$(0.059 \text{ lb S/hr})(2 \text{ lb SO}_2/\text{lb S}) = 0.117 \text{ lb SO}_2/\text{hr}$<br>$(0.117 \text{ lb SO}_2/\text{hr})(100 \text{ hr/yr})(1 \text{ ton}/2000 \text{ lb}) = 0.006 \text{ ton/yr}$ |  |   |  |
| 11. Potential, Fugitive, and Actual Emissions Comment:<br><br>Calculations based on emergency generator usage of 100 hours per year.  |  |   |  |



**F2. EMISSIONS UNIT POLLUTANT DETAIL INFORMATION -  
 ALLOWABLE EMISSIONS**

**Complete Subsection F2 if the pollutant identified in Subsection F1 is or would be subject to a numerical emissions limitation.**

**Allowable Emissions** Allowable Emissions NA of

|   |  |
|---|--|
| 1. Basis for Allowable Emissions Code:                            | 2. Future Effective Date of Allowable Emissions: NA                          |
| 3. Allowable Emissions and Units:                                 | 4. Equivalent Allowable Emissions:<br>lb/hour                      tons/year |
| 5. Method of Compliance:  |  |
| 6. Allowable Emissions Comment (Description of Operating Method): |  |

**Allowable Emissions** Allowable Emissions    of   

|   |  |
|---|--|
| 1. Basis for Allowable Emissions Code:                            | 2. Future Effective Date of Allowable Emissions:                             |
| 3. Allowable Emissions and Units:                                 | 4. Equivalent Allowable Emissions:<br>lb/hour                      tons/year |
| 5. Method of Compliance:  |  |
| 6. Allowable Emissions Comment (Description of Operating Method): |  |

**Allowable Emissions** Allowable Emissions    of   

|   |  |
|---|--|
| 1. Basis for Allowable Emissions Code:                            | 2. Future Effective Date of Allowable Emissions:                             |
| 3. Allowable Emissions and Units:                                 | 4. Equivalent Allowable Emissions:<br>lb/hour                      tons/year |
| 5. Method of Compliance:  |  |
| 6. Allowable Emissions Comment (Description of Operating Method): |  |

**EMISSIONS UNIT INFORMATION**

Section [ 3 ] of [ 3 ]

**POLLUTANT DETAIL INFORMATION**

Page [ 5 ] of [ 6 ]

**F1. EMISSIONS UNIT POLLUTANT DETAIL INFORMATION –  
POTENTIAL, FUGITIVE, AND ACTUAL EMISSIONS**

(Optional for unregulated emissions units.)

Complete a Subsection F1 for each pollutant identified in Subsection E if applying for an air construction permit or concurrent processing of an air construction permit and a revised or renewal Title V operation permit. Complete for each emissions-limited pollutant identified in Subsection E if applying for an air operation permit.

**Potential, Estimated Fugitive, and Baseline & Projected Actual Emissions**

|   |  |   |  |
|---|--|---|--|
| 1. Pollutant Emitted:<br>PM   |  | 2. Total Percent Efficiency of Control:   |  |
| 3. Potential Emissions:<br>0.083 lb/hour                      0.004 tons/year   |  | 4. Synthetically Limited?<br><input checked="" type="checkbox"/> Yes <input type="checkbox"/> No        |  |
| 5. Range of Estimated Fugitive Emissions (as applicable): NA<br>to tons/year  |  |   |  |
| 6. Emission Factor: 0.01941 lb/MM Btu<br><br>Reference: Table 3.2-3, AP-42 7/00   |  | 7. Emissions Method Code:<br>3  |  |
| 8.a. Baseline Actual Emissions (if required):<br>NA tons/year   |  | 8.b. Baseline 24-month Period:<br>From:                      To:  |  |
| 9.a. Projected Actual Emissions (if required):<br>NA tons/year  |  | 9.b. Projected Monitoring Period:<br><input type="checkbox"/> 5 years <input type="checkbox"/> 10 years |  |
| 10. Calculation of Emissions:<br><br>$(0.01941 \text{ lb/MM Btu})(4.26 \text{ MM Btu/hr}) = 0.083 \text{ lb/hr}$<br>$(0.083 \text{ lb/hr})(100 \text{ hr/yr})(1 \text{ ton}/2000 \text{ lb}) = 0.004 \text{ ton/y}$ |  |   |  |
| 11. Potential, Fugitive, and Actual Emissions Comment:<br><br>Calculations based on emergency generator usage of 100 hours per year.  |  |   |  |

**F2. EMISSIONS UNIT POLLUTANT DETAIL INFORMATION -  
ALLOWABLE EMISSIONS**

**Complete Subsection F2 if the pollutant identified in Subsection F1 is or would be subject to a numerical emissions limitation.**

**Allowable Emissions** Allowable Emissions NA of

|   |  |
|---|--|
| 1. Basis for Allowable Emissions Code:                            | 2. Future Effective Date of Allowable Emissions: NA                          |
| 3. Allowable Emissions and Units:                                 | 4. Equivalent Allowable Emissions:<br>lb/hour                      tons/year |
| 5. Method of Compliance:  |  |
| 6. Allowable Emissions Comment (Description of Operating Method): |  |

**Allowable Emissions** Allowable Emissions \_\_\_ of \_\_\_

|   |  |
|---|--|
| 1. Basis for Allowable Emissions Code:                            | 2. Future Effective Date of Allowable Emissions:                             |
| 3. Allowable Emissions and Units:                                 | 4. Equivalent Allowable Emissions:<br>lb/hour                      tons/year |
| 5. Method of Compliance:  |  |
| 6. Allowable Emissions Comment (Description of Operating Method): |  |

**Allowable Emissions** Allowable Emissions \_\_\_ of \_\_\_

|   |  |
|---|--|
| 1. Basis for Allowable Emissions Code:                            | 2. Future Effective Date of Allowable Emissions:                             |
| 3. Allowable Emissions and Units:                                 | 4. Equivalent Allowable Emissions:<br>lb/hour                      tons/year |
| 5. Method of Compliance:  |  |
| 6. Allowable Emissions Comment (Description of Operating Method): |  |

**EMISSIONS UNIT INFORMATION**

Section | 3 | of | 3 |

**POLLUTANT DETAIL INFORMATION**

Page | 6 | of | 6 |

**F1. EMISSIONS UNIT POLLUTANT DETAIL INFORMATION –  
POTENTIAL, FUGITIVE, AND ACTUAL EMISSIONS  
(Optional for unregulated emissions units.)**

**Complete a Subsection F1 for each pollutant identified in Subsection E if applying for an air construction permit or concurrent processing of an air construction permit and a revised or renewal Title V operation permit. Complete for each emissions-limited pollutant identified in Subsection E if applying for an air operation permit.**

**Potential, Estimated Fugitive, and Baseline & Projected Actual Emissions**

|   |  |   |  |
|---|--|---|--|
| 1. Pollutant Emitted:<br>HAPS   |  | 2. Total Percent Efficiency of Control:   |  |
| 3. Potential Emissions:<br>0.10 lb/hour                      0.005 tons/year  |  | 4. Synthetically Limited?<br><input checked="" type="checkbox"/> Yes <input type="checkbox"/> No        |  |
| 5. Range of Estimated Fugitive Emissions (as applicable): NA<br>to tons/year  |  |   |  |
| 6. Emission Factor: 0.0234 lb/MM Btu<br><br>Reference: AP-42, Table 3.2-3   |  | 7. Emissions Method Code:<br>3  |  |
| 8.a. Baseline Actual Emissions (if required):<br>NA tons/year   |  | 8.b. Baseline 24-month Period:<br>From:                      To:  |  |
| 9.a. Projected Actual Emissions (if required):<br>NA tons/year  |  | 9.b. Projected Monitoring Period:<br><input type="checkbox"/> 5 years <input type="checkbox"/> 10 years |  |
| 10. Calculation of Emissions:<br><br>$(0.0234 \text{ lb/MM Btu})(4.26 \text{ MM Btu/hr}) = 0.10 \text{ lb/hr}$<br>$(0.10 \text{ lb/hr})(8760 \text{ hr/yr})(1 \text{ ton}/2000 \text{ lb}) = 0.005 \text{ ton/y}$ |  |   |  |
| 11. Potential, Fugitive, and Actual Emissions Comment:<br><br>Calculations based on emergency generator usage of 100 hours per year.  |  |   |  |

**F2. EMISSIONS UNIT POLLUTANT DETAIL INFORMATION -  
ALLOWABLE EMISSIONS**

**Complete Subsection F2 if the pollutant identified in Subsection F1 is or would be subject to a numerical emissions limitation.**

**Allowable Emissions** Allowable Emissions NA of

|   |  |
|---|--|
| 1. Basis for Allowable Emissions Code:                            | 2. Future Effective Date of Allowable Emissions: NA                          |
| 3. Allowable Emissions and Units:                                 | 4. Equivalent Allowable Emissions:<br>lb/hour                      tons/year |
| 5. Method of Compliance:  |  |
| 6. Allowable Emissions Comment (Description of Operating Method): |  |

**Allowable Emissions** Allowable Emissions    of   

|   |  |
|---|--|
| 1. Basis for Allowable Emissions Code:                            | 2. Future Effective Date of Allowable Emissions:                             |
| 3. Allowable Emissions and Units:                                 | 4. Equivalent Allowable Emissions:<br>lb/hour                      tons/year |
| 5. Method of Compliance:  |  |
| 6. Allowable Emissions Comment (Description of Operating Method): |  |

**Allowable Emissions** Allowable Emissions    of   

|   |  |
|---|--|
| 1. Basis for Allowable Emissions Code:                            | 2. Future Effective Date of Allowable Emissions:                             |
| 3. Allowable Emissions and Units:                                 | 4. Equivalent Allowable Emissions:<br>lb/hour                      tons/year |
| 5. Method of Compliance:  |  |
| 6. Allowable Emissions Comment (Description of Operating Method): |  |



**EMISSIONS UNIT INFORMATION**

Section [ 3 ] of [ 3 ]

**H. CONTINUOUS MONITOR INFORMATION**

**Complete Subsection H if this emissions unit is or would be subject to continuous monitoring.**

**Continuous Monitoring System:** Continuous Monitor NA of   

|  |  |
|--|--|
| 1. Parameter Code:   | 2. Pollutant(s):   |
| 3. CMS Requirement:  | <input type="checkbox"/> Rule <input type="checkbox"/> Other |
| 4. Monitor Information...<br>Manufacturer:<br>Model Number: Serial Number: |  |
| 5. Installation Date:  | 6. Performance Specification Test Date:                      |
| 7. Continuous Monitor Comment:   |  |

**Continuous Monitoring System:** Continuous Monitor    of   

|  |  |
|--|--|
| 1. Parameter Code:   | 2. Pollutant(s):   |
| 3. CMS Requirement:  | <input type="checkbox"/> Rule <input type="checkbox"/> Other |
| 4. Monitor Information...<br>Manufacturer:<br>Model Number: Serial Number: |  |
| 5. Installation Date:  | 6. Performance Specification Test Date:                      |
| 7. Continuous Monitor Comment:   |  |

**EMISSIONS UNIT INFORMATION**

Section | 3 | of | 3 |

**I. EMISSIONS UNIT ADDITIONAL INFORMATION**

**Additional Requirements for All Applications, Except as Otherwise Stated**

|   |
|---|
| 1. Process Flow Diagram: (Required for all permit applications, except Title V air operation permit revision applications if this information was submitted to the department within the previous five years and would not be altered as a result of the revision being sought)<br><input checked="" type="checkbox"/> Attached, Document ID: <u>Attach. B</u> <input type="checkbox"/> Previously Submitted, Date _____  |
| 2. Fuel Analysis or Specification: (Required for all permit applications, except Title V air operation permit revision applications if this information was submitted to the department within the previous five years and would not be altered as a result of the revision being sought)<br><input checked="" type="checkbox"/> Attached, Document ID: <u>Attach. G</u> <input type="checkbox"/> Previously Submitted, Date _____  |
| 3. Detailed Description of Control Equipment: (Required for all permit applications, except Title V air operation permit revision applications if this information was submitted to the department within the previous five years and would not be altered as a result of the revision being sought)<br><input checked="" type="checkbox"/> Attached, Document ID: <u>See note below</u> <input type="checkbox"/> Previously Submitted, Date _____  |
| 4. Procedures for Startup and Shutdown: (Required for all operation permit applications, except Title V air operation permit revision applications if this information was submitted to the department within the previous five years and would not be altered as a result of the revision being sought)<br><input type="checkbox"/> Attached, Document ID: _____ <input type="checkbox"/> Previously Submitted, Date _____<br><input checked="" type="checkbox"/> Not Applicable (construction application)  |
| 5. Operation and Maintenance Plan: (Required for all permit applications, except Title V air operation permit revision applications if this information was submitted to the department within the previous five years and would not be altered as a result of the revision being sought)<br><input type="checkbox"/> Attached, Document ID: _____ <input type="checkbox"/> Previously Submitted, Date _____<br><input checked="" type="checkbox"/> Not Applicable  |
| 6. Compliance Demonstration Reports/Records:<br><input type="checkbox"/> Attached, Document ID: _____<br>Test Date(s)/Pollutant(s) Tested: _____<br><input type="checkbox"/> Previously Submitted, Date: _____<br>Test Date(s)/Pollutant(s) Tested: _____<br><input type="checkbox"/> To be Submitted, Date (if known): _____<br>Test Date(s)/Pollutant(s) Tested: _____<br><input checked="" type="checkbox"/> Not Applicable<br>Note: For FESOP applications, all required compliance demonstration records/reports must be submitted at the time of application. For Title V air operation permit applications, all required compliance demonstration reports/records must be submitted at the time of application, or a compliance plan must be submitted at the time of application. |
| 7. Other Information Required by Rule or Statute:<br><input type="checkbox"/> Attached, Document ID: _____ <input checked="" type="checkbox"/> Not Applicable   |



**EMISSIONS UNIT INFORMATION**

Section [ 3 ] of [ 3 ]

**I. EMISSIONS UNIT ADDITIONAL INFORMATION (CONTINUED)**

**Additional Requirements for Air Construction Permit Applications**

|  |
|--|
| 1. Control Technology Review and Analysis (Rules 62-212.400(10) and 62-212.500(7), F.A.C.; 40 CFR 63.43(d) and (e)):<br><input checked="" type="checkbox"/> Attached, Document ID: <u>Narr. Sec. 3.0</u> <input type="checkbox"/> Not Applicable |
| 2. Good Engineering Practice Stack Height Analysis (Rules 62-212.400(4)(d) and 62-212.500(4)(f), F.A.C.):<br><input type="checkbox"/> Attached, Document ID: _____ <input checked="" type="checkbox"/> Not Applicable                            |
| 3. Description of Stack Sampling Facilities: (Required for proposed new stack sampling facilities only)<br><input checked="" type="checkbox"/> Attached, Document ID: <u>See note below</u> <input type="checkbox"/> Not Applicable              |

**Additional Requirements for Title V Air Operation Permit Applications**

|   |
|---|
| 1. Identification of Applicable Requirements:<br><input type="checkbox"/> Attached, Document ID: <u>NA</u>  |
| 2. Compliance Assurance Monitoring:<br><input type="checkbox"/> Attached, Document ID: _____ <input type="checkbox"/> Not Applicable                    |
| 3. Alternative Methods of Operation:<br><input type="checkbox"/> Attached, Document ID: _____ <input type="checkbox"/> Not Applicable                   |
| 4. Alternative Modes of Operation (Emissions Trading):<br><input type="checkbox"/> Attached, Document ID: _____ <input type="checkbox"/> Not Applicable |

**Additional Requirements Comment**

Supplemental information is provided in the narrative description accompanying these forms.

The manufacturer has not completed design specifications and has not provided final emission rates at this time. Emissions will comply with applicable 40 CFR Subpart JJJ requirements.

Specifications for the sampling facilities have not been completed at this time. Final specifications will comply with USEPA and FDEP regulatory requirements.

**Attachment B**  
**Process Flow Diagram**

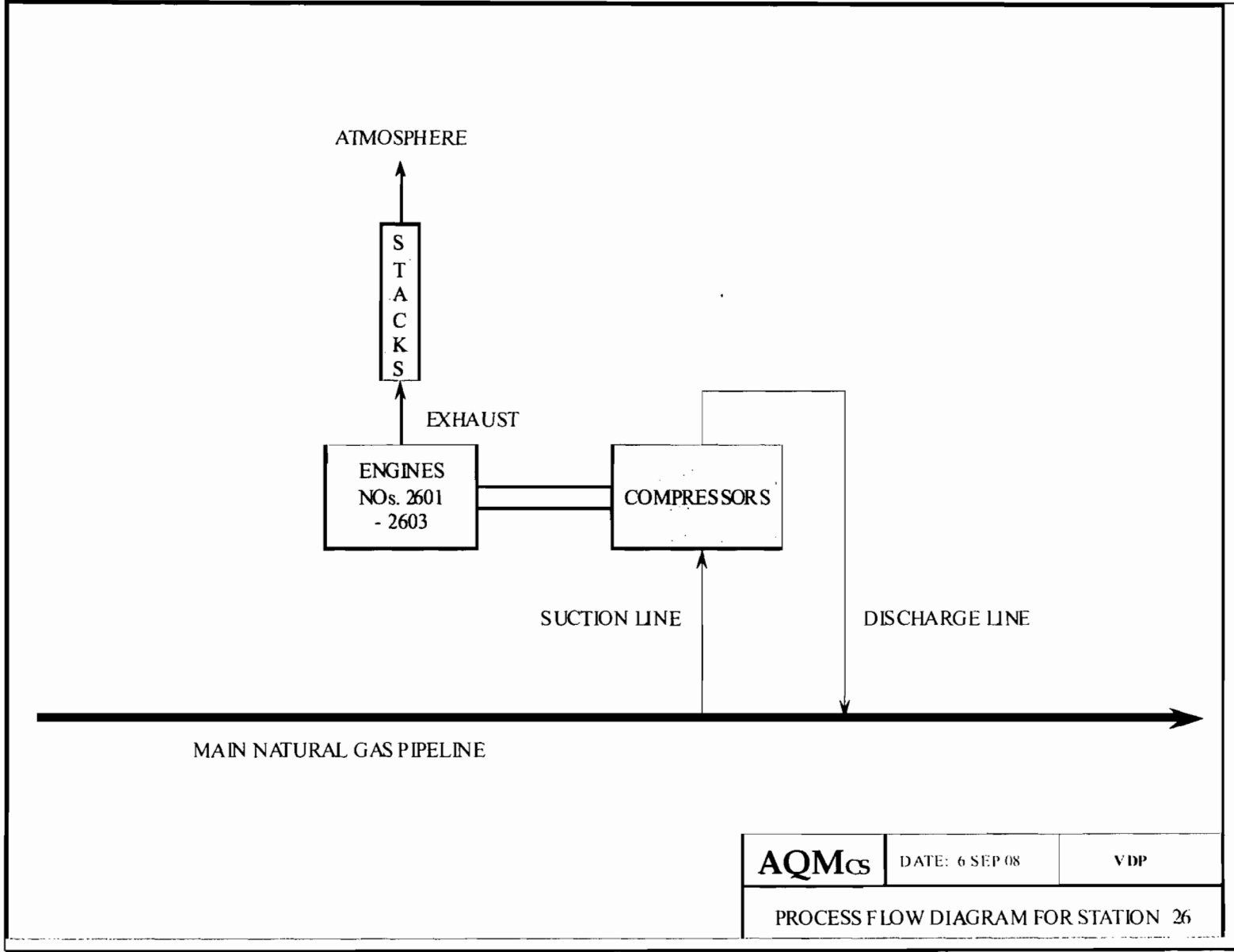

|                                     |                |     |
|-------------------------------------|----------------|-----|
| <b>AQMcs</b>                        | DATE: 6 SEP 08 | VDP |
| PROCESS FLOW DIAGRAM FOR STATION 26 |                |     |

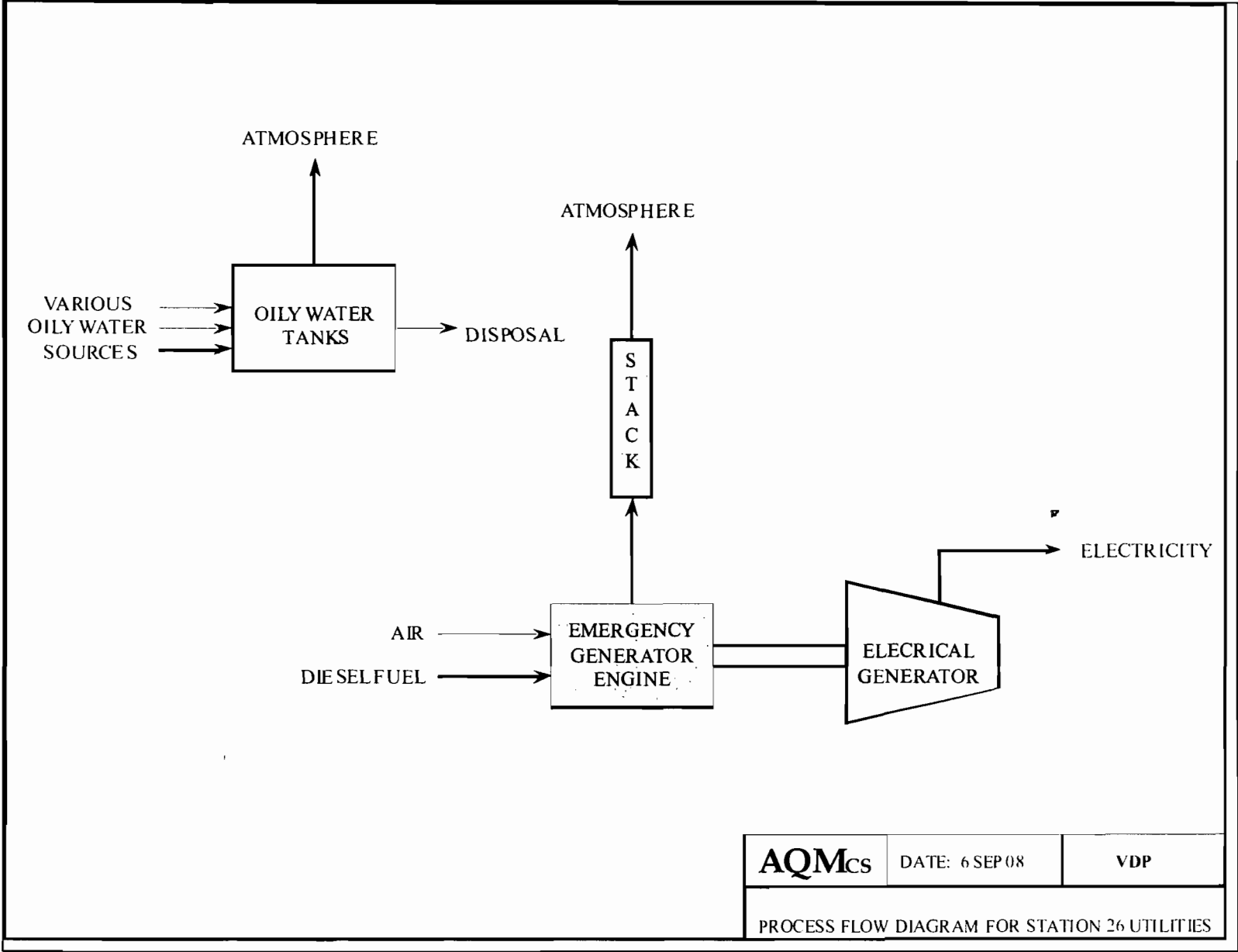

|   |                |            |
|---|----------------|------------|
| <b>AQM</b> Cs                                 | DATE: 6 SEP 08 | <b>VDP</b> |
| PROCESS FLOW DIAGRAM FOR STATION 26 UTILITIES |                |            |

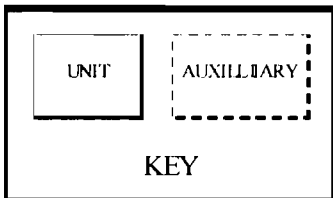
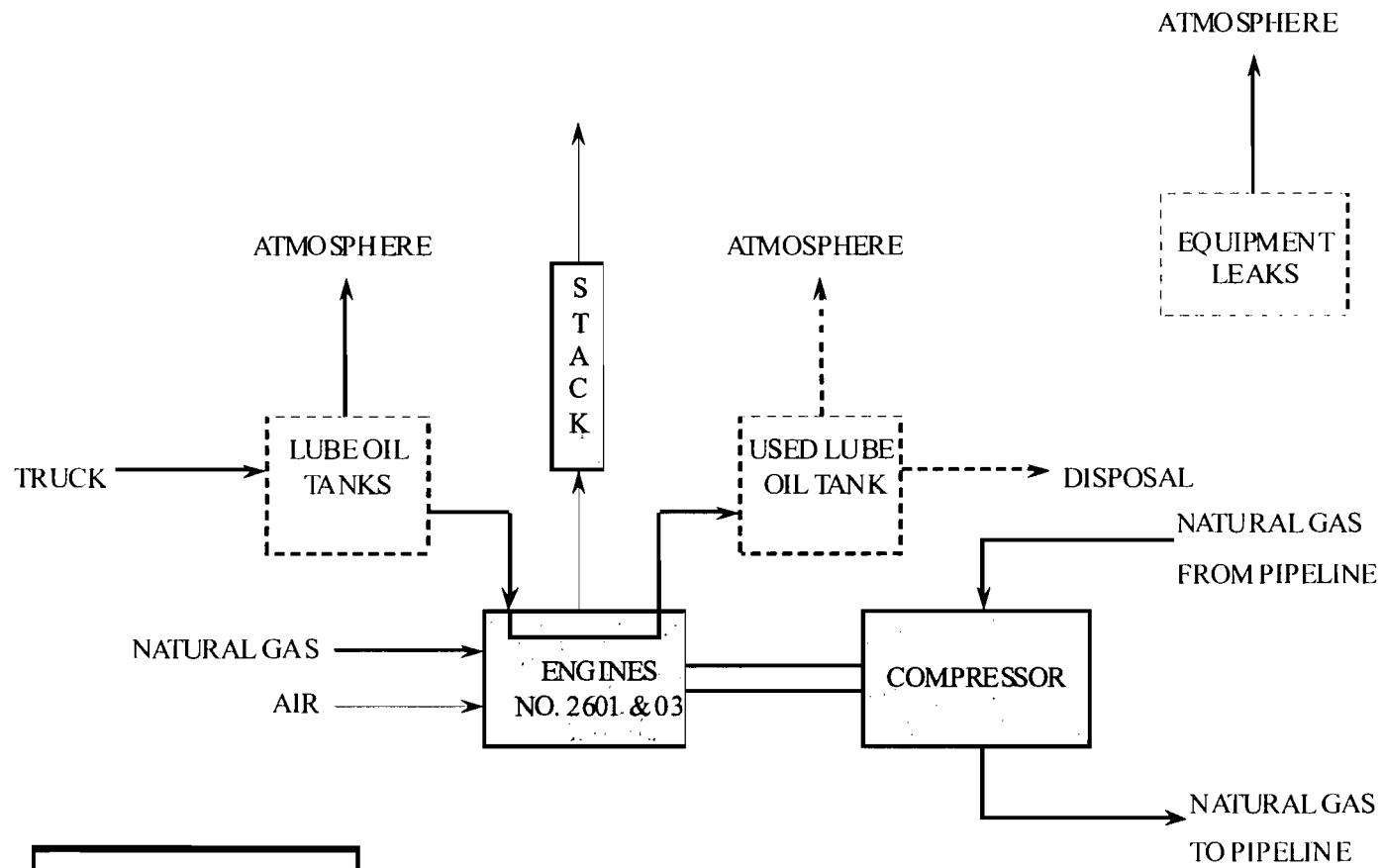

|  |               |     |
|--|---------------|-----|
| <b>AQM<sub>CS</sub></b>                  | DATE: 6 SEP08 | VDP |
| PROCESS FLOW DIAGRAM FOR EUs 2601 & 2603 |               |     |

## **Attachment C**

### **Precautions to Prevent Emissions of Unconfined Particulate Matter**

## **Precautions to Prevent Emissions of Unconfined Particulate Matter**

Precautions that will be taken to prevent unconfined emissions of unconfined particulate matter include:

- a) Chemical or water application to unpaved roads and unpaved yard areas;
- b) Paving and maintenance of roads, parking areas and yards; Landscaping or planting of vegetation;
- d) Other techniques, as necessary.

## **Attachment D**

### **Plot Plan**



FILE #10 I:\BICMAC\F.0810A GAS TRANSMISSION\08952 STATION 26\DWG\STA 26\ST-26-OC.DWG 1=2400.0000 SEPTEMBER 26, 2008 2:06 PM NORMA WRIGHT

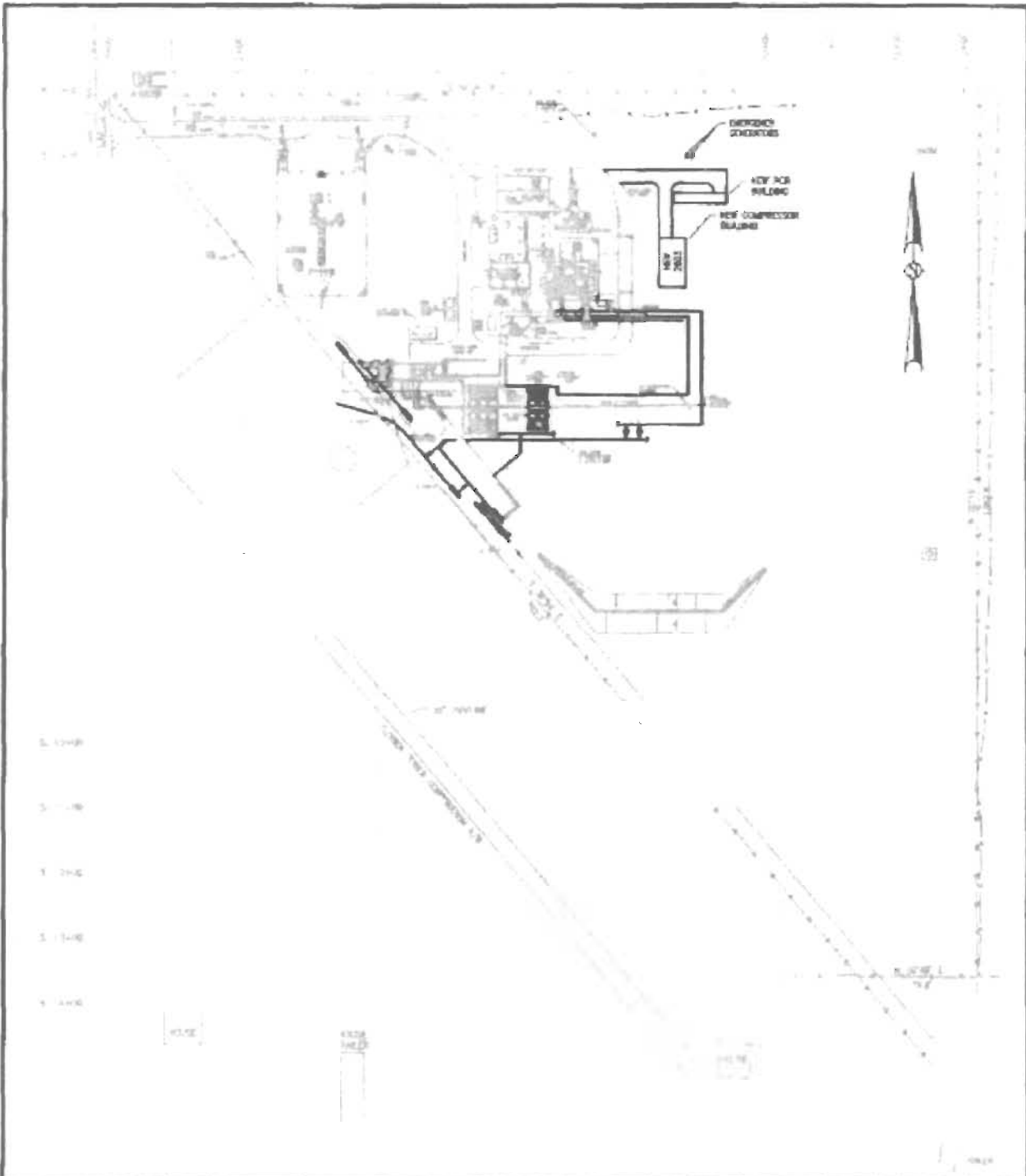

|                                     |               |          |          |   |  |                 |  |
|-------------------------------------|---------------|----------|----------|---|--|-----------------|--|
| PRESSURE, STATION OR ACCOUNT NUMBER |               | SCALE    |          | CONSTR  |  | PROJECT NO      |  |
|                                     |               | 1"=200'  |          |   |  | 622025          |  |
| FILENUMBER                          | CADD FILENAME | DRAWN    | DATE     | Florida Gas Transmission Co.<br>Houston, Texas  |  | PREVIOUS DWG NO |  |
| A                                   | S1-26-OC.DWG  | N/W      | 06/25/08 | PHASE VIII EXPANSION<br>STATION 26<br>PLOT PLAN |  | S1-26-OC        |  |
| RTY NO - DESCRIPTION                | BY            | DATE     | APP      | CITRUS COUNTY, FLORIDA                          |  | SHT 1 OF 1      |  |
| A ISSUED FOR CLIENT REVIEW          | N/W           | 08/28/08 | RTS      |   |  | DWG NO          |  |
|                                     |               |          |          |   |  | S1-26-OC        |  |
|                                     |               |          |          |   |  | SHT 1 OF 1      |  |
|                                     |               |          |          |   |  |                 |  |

**Attachment E**

**Vendor Information**

**Solar Model Titan T-20500S Turbine**

**Generac SG300**

**Solar Model Titan T-20500S Turbine**

# Solar Turbines

A Caterpillar Company

## PREDICTED EMISSION PERFORMANCE

|                                |                              |
|--------------------------------|------------------------------|
| Customer<br><b>FGT</b>         |                              |
| Job ID<br><b>HO08-0024</b>     |                              |
| Inquiry Number                 |                              |
| Run By<br><b>James Belmont</b> | Date Run<br><b>10-Jul-08</b> |

|   |                              |
|---|------------------------------|
| Engine Model<br><b>TITAN 130-20502S</b><br><b>CS/MD 59F MATCH</b> |                              |
| Fuel Type<br><b>SD NATURAL GAS</b>                                | Water Injection<br><b>NO</b> |
| Engine Emissions Data<br><b>REV. 0.0</b>                          |                              |

### NOx EMISSIONS

### CO EMISSIONS

### UHC EMISSIONS

|          |                                |                    |                   |                            |                                |
|----------|--------------------------------|--------------------|-------------------|----------------------------|--------------------------------|
| <b>1</b> | <b>19465 Hp</b>                | <b>100.0% Load</b> | <b>Elev. 0 ft</b> | <b>Rel. Humidity 60.0%</b> | <b>Temperature 59.0 Deg. F</b> |
|          | <b>PPMvd at 15% O2</b>         |                    |                   |                            |                                |
|          | <b>ton/yr</b>                  | <b>15.00</b>       | <b>25.00</b>      | <b>25.00</b>               |                                |
|          | <b>lbm/MMBtu (Fuel LHV)</b>    | <b>37.31</b>       | <b>37.86</b>      | <b>21.69</b>               |                                |
|          | <b>lbm/(MW-hr)</b>             | <b>0.060</b>       | <b>0.061</b>      | <b>0.035</b>               |                                |
|          | <b>(gas turbine shaft pwr)</b> | <b>0.59</b>        | <b>0.60</b>       | <b>0.34</b>                |                                |
|          | <b>lbm/hr</b>                  | <b>8.52</b>        | <b>8.64</b>       | <b>4.95</b>                |                                |

#### Notes

1. For short-term emission limits such as lbs/hr., Solar recommends using "worst case" anticipated operating conditions specific to the application and the site conditions. Worst case for one pollutant is not necessarily the same for another.
2. Solar's typical SoLoNOx warranty, for ppm values, is available for greater than 0 deg F, and between 50% and 100% load for gas fuel, and between 65% and 100% load for liquid fuel (except for the Centaur 40). An emission warranty for non-SoLoNOx equipment is available for greater than 0 deg F and between 80% and 100% load.
3. Fuel must meet Solar standard fuel specification ES 9-98. Emissions are based on the attached fuel composition, or, San Diego natural gas or equivalent.
4. If needed, Solar can provide Product Information Letters to address turbine operation outside typical warranty ranges, as well as non-warranted emissions of SO2, PM10/2.5, VOC, and formaldehyde.
5. Solar can provide factory testing in San Diego to ensure the actual unit(s) meet the above values within the tolerances quoted. Pricing and schedule impact will be provided upon request.
6. Any emissions warranty is applicable only for steady-state conditions and does not apply during start-up, shut-down, malfunction, or transient event.

# Solar Turbines

A Caterpillar Company

## PREDICTED ENGINE PERFORMANCE

|   |  |
|---|--|
| Customer<br><b>FGT</b>                      |  |
| Job ID<br><b>HO08-0024</b>                  |  |
| Run By<br><b>James Belmont</b>              | Date Run<br><b>10-Jul-08</b>               |
| Engine Performance Code<br><b>REV. 3.40</b> | Engine Performance Data<br><b>REV. 1.0</b> |

|                                    |
|------------------------------------|
| Model<br><b>TITAN 130-20502S</b>   |
| Package Type<br><b>CS/MD</b>       |
| Match<br><b>59F MATCH</b>          |
| Fuel System<br><b>GAS</b>          |
| Fuel Type<br><b>SD NATURAL GAS</b> |

### DATA FOR MINIMUM PERFORMANCE

|                          |           |               |
|--------------------------|-----------|---------------|
| Elevation                | feet      | <b>0</b>      |
| Inlet Loss               | in H2O    | <b>4.0</b>    |
| Exhaust Loss             | in H2O    | <b>4.0</b>    |
| Engine Inlet Temperature | deg F     | <b>59.0</b>   |
| Relative Humidity        | %         | <b>60.0</b>   |
| Driven Equipment Speed   | RPM       | <b>8351</b>   |
| Specified Load           | HP        | <b>FULL</b>   |
| Net Output Power         | HP        | <b>19465</b>  |
| Fuel Flow                | mmBtu/hr  | <b>142.59</b> |
| Heat Rate                | Btu/HP-hr | <b>7326</b>   |
| Therm Eff                | %         | <b>34.732</b> |
| Engine Exhaust Flow      | lbm/hr    | <b>393041</b> |
| Exhaust Temperature      | deg F     | <b>944</b>    |

|                                       |                        |               |
|---------------------------------------|------------------------|---------------|
| Fuel Gas Composition (Volume Percent) | Methane (CH4)          | <b>92.79</b>  |
|                                       | Ethane (C2H6)          | <b>4.16</b>   |
|                                       | Propane (C3H8)         | <b>0.84</b>   |
|                                       | N-Butane (C4H10)       | <b>0.18</b>   |
|                                       | N-Pentane (C5H12)      | <b>0.04</b>   |
|                                       | Hexane (C6H14)         | <b>0.04</b>   |
|                                       | Carbon Dioxide (CO2)   | <b>0.44</b>   |
|                                       | Hydrogen Sulfide (H2S) | <b>0.0001</b> |
|                                       | Nitrogen (N2)          | <b>1.51</b>   |

|                     |               |              |                  |               |                    |               |
|---------------------|---------------|--------------|------------------|---------------|--------------------|---------------|
| Fuel Gas Properties | LHV (Btu/Scf) | <b>939.2</b> | Specific Gravity | <b>0.5970</b> | Wobbe Index at 60F | <b>1215.6</b> |
|---------------------|---------------|--------------|------------------|---------------|--------------------|---------------|

*This performance was calculated with a basic inlet and exhaust system. Special equipment such as low noise silencers, special filters, heat recovery systems or cooling devices will affect engine performance. Performance shown is "Expected" performance at the pressure drops stated, not guaranteed.*

**Generac SG300**



# SG275 SG300

## Liquid Cooled Gas Engine Generator Sets

### Standby Power Rating

275 KW 60 Hz / 275 KVA 50 Hz

300 KW 60 Hz / 300 KVA 50 Hz

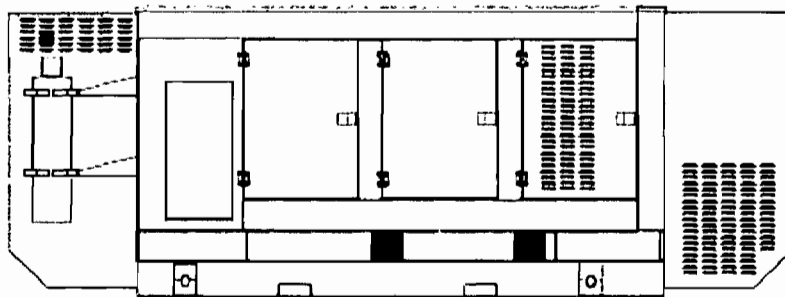

Power Matched  
**GENERAC**  
**13.3GTA ENGINE**  
Turbocharged/Aftercooled

## FEATURES

- **INNOVATIVE DESIGN & PROTOTYPE TESTING** are key components of GENERAC'S success in "IMPROVING POWER BY DESIGN." Built doesn't stop there. Total commitment to component testing, reliability testing, environmental testing, destruction and life testing, plus testing to applicable CSA, NEMA, EGSA, and other standards, allows you to choose GENERAC POWER SYSTEMS with the confidence that these systems will provide superior performance.
- **TEST CRITERIA:**
  - ✓ PROTOTYPE TESTED
  - ✓ SYSTEM TORSIONAL TESTED
  - ✓ ELECTRO-MAGNETIC INTERFERENCE
  - ✓ NEMA MG1 EVALUATION
  - ✓ MOTOR STARTING ABILITY
  - ✓ SHORT CIRCUIT TESTING
  - ✓ UL2200 COMPLIANCE AVAILABLE
- **SOLID-STATE, FREQUENCY COMPENSATED DIGITAL VOLTAGE REGULATION.** This state-of-the-art power maximizing regulation system is standard on all Generac models. It provides optimized **FAST RESPONSE** to changing load conditions and **MAXIMUM MOTOR STARTING CAPABILITY** by electronically torque-matching the surge loads to the engine.
- **SINGLE SOURCE SERVICE RESPONSE** from Generac's dealer network provides parts and service know-how for the entire unit, from the engine to the smallest electronic component. You are never on your own when you own a GENERAC POWER SYSTEM.
- **GENERAC TRANSFER SWITCHES, SWITCHGEAR AND ACCESSORIES.** Long life and reliability is synonymous with GENERAC POWER SYSTEMS. One reason for this confidence is that the GENERAC product line includes its own transfer systems, accessories, switchgear and controls for total system compatibility.

# GENERAC®

---

## POWER SYSTEMS, INC.



# APPLICATION & ENGINEERING DATA

SG275/SG300

## GENERATOR SPECIFICATIONS

|                                  |                                |
|----------------------------------|--------------------------------|
| TYPE                             | Four-pole, revolving field     |
| ROTOR INSULATION                 | Class H                        |
| STATOR INSULATION                | Class H                        |
| TOTAL HARMONIC DISTORTION        | <3.0%                          |
| TELEPHONE INFLUENCE FACTOR (TIF) | <50                            |
| ALTERNATOR                       | Self-ventilated and drip-proof |
| BEARINGS (PRE-LUBED & SEALED)    | 2                              |
| COUPLING                         | Flexible Disc                  |
| LOAD CAPACITY (STANDBY)          | 100%                           |

**NOTE:** Generator rating and performance in accordance with ISO6526-5, BS5514, SAE J1349, ISO3046 and DIN6271 standards.

### EXCITATION SYSTEM

|                                |  |
|--------------------------------|--|
| PERMANENT MAGNET PILOT EXCITER | Eighteen-pole exciter ✓<br>Magnetically coupled DC current ✓<br>Mounted outboard of main bearing ✓ |
| REGULATION                     | H100 Controller Digital ✓<br>3 Phase Sensing, ± 1% regulation ✓                                    |

## GENERATOR FEATURES

- Revolving field heavy duty generator
- Directly connected to the engine
- Operating temperature rise 120 °C above a 40 °C ambient
- Insulation is Class H rated at 150 °C rise
- All prototype models have passed three phase short circuit testing
- PMG

## CONTROL PANEL FEATURES

- TWO FOUR LINE LCD DISPLAYS READ:
  - Voltage (all phases)
  - Power factor
  - kW
  - Engine speed
  - Run hours
  - Fault history
  - Coolant temperature
  - Low oil pressure shutdown
  - Overspeed
  - Low coolant level
  - Not in auto position (flashing light)
  - ATS selection
  - Current (all phases)
  - kW
  - Transfer switch status
  - Low fuel pressure
  - Service reminders
  - Oil pressure
  - Time and date
  - High coolant temperature shutdown
  - Overspeed
  - Low coolant level
  - Exercise speed
- INTERNAL FUNCTIONS:
  - IT function for alternator protection from line to neutral and line to line short circuits
  - Emergency stop
  - Programmable auto crank function
  - 2 wire start for any transfer switch
  - Communicates with the Generac HTS transfer switch
  - Built-in 7 day exerciser
  - Adjustable engine speed at exerciser
  - RS232 port for GenLink® control
  - RS485 port remote communication
  - Canbus addressable
  - Governor controller and voltage regulator are built into the master control board
  - Temperature range -40 °C to 70 °C

**Rating Definitions:** - Standby: Applicable for supplying emergency power for the duration of the utility power outage. No overload capability is available for this rating. (All ratings in accordance with BS5514, ISO3046 and DIN6271). Prime/Unlimited Running Time: Applicable for supplying electric power in lieu of commercially purchased power. Prime power is the maximum power available at variable load. A 10% overload capacity is available for 1 hour in 12 hours. (All ratings in accordance with BS5514, ISO3046, ISO6529 and DIN6271).

## ENGINE SPECIFICATIONS

|                         |   |
|-------------------------|---|
| MAKE                    | GENERAC                                     |
| MODEL                   | 13.9GTA                                     |
| CYLINDERS               | 6 In-line                                   |
| DISPLACEMENT            | 13.9 Liter (81.1 cu. in.)                   |
| BORE                    | 137 mm (5.39 in.)                           |
| STROKE                  | 150 mm (5.91 in.)                           |
| COMPRESSION RATIO       | 10.5:1                                      |
| INTAKE AIR              | Turbocharged/Aircooled                      |
| NUMBER OF MAIN BEARINGS | 7   |
| CONNECTING RODS         | 6-Carbon Steel                              |
| CYLINDER HEAD           | Cast Iron with Overhead Valve               |
| CYLINDER LINERS         | Wet/Replaceable                             |
| IGNITION                | Electronic CDI                              |
| PISTONS                 | Heat-Resistant Alloy with 4 Rings           |
| CRANKSHAFT              | Induction-Hardened, Die-Forged Carbon Steel |

### VALVE TRAIN

|                        |                                 |
|------------------------|---------------------------------|
| LIFTER TYPE            | Solid                           |
| INTAKE VALVE MATERIAL  | Special Heat Resistant Steel    |
| EXHAUST VALVE MATERIAL | Inconel Alloy High Temp.        |
| HARDENED VALVE SEATS   | High Temp. Alloy Stainless Food |

### ENGINE GOVERNOR

|  |                |
|--|----------------|
| ELECTRONIC                                 | Standard       |
| FREQUENCY REGULATION, NO-LOAD TO FULL LOAD | Isosynchronous |
| STEADY STATE REGULATION                    | ±0.25%         |

### LUBRICATION SYSTEM

|                    |                       |
|--------------------|-----------------------|
| TYPE OF OIL PUMP   | Gear Driven           |
| OIL FILTER         | Full flow, cartridge  |
| CRANKCASE CAPACITY | 27 Liters (7.18 gal.) |

### COOLING SYSTEM

|                      |                              |
|----------------------|------------------------------|
| TYPE OF SYSTEM       | Pressurized, closed recovery |
| WATER PUMP           | Pre-lubed, self-sealing      |
| TYPE OF FAN          | Pusher                       |
| NUMBER OF FAN BLADES | 8                            |
| DIAMETER OF FAN      | 39 in.                       |
| COOLANT HEATER       | 240V, 2000 W                 |

### FUEL SYSTEM

|                                 |  |
|---------------------------------|--|
| FUEL                            | <input type="checkbox"/> Natural Gas..... Standard |
| CARBURETOR                      | Down draft   |
| SECONDARY FUEL REGULATOR        | Not Gas  |
| AUTOMATIC FUEL LOCKOFF SOLENOID | Standard   |
| OPERATING FUEL PRESSURE SYSTEMS | 10" to 15" H <sub>2</sub> O                        |

### ELECTRICAL SYSTEM

|                           |                         |
|---------------------------|-------------------------|
| BATTERY CHARGE ALTERNATOR | 20 Amps at 24 V         |
| STARTER MOTOR             | 24 V                    |
| RECOMMENDED BATTERY       | (2) - 12 V, 925 CCA, 31 |
| GROUND POLARITY           | Negative                |

SG275/SG300

| OPERATING DATA  |  | SG275  |  | SG300  |   |
|---|--|--|--|--|---|
| <b>GENERATOR OUTPUT VOLTAGE/KW-60Hz</b><br>120/200V, 3-phase, 0.8 pf<br>120/240V, 3-phase, 0.8 pf<br>277/480V, 3-phase, 0.8 pf<br>600V, 3-phase, 0.8 pf<br><small>NOTE: Consult your Generac dealer for additional voltage.</small>   |  | <b>KW</b><br>275<br>275<br>275<br>275                                  | <b>Rated AMP</b><br>954<br>827<br>413<br>331 | <b>KW</b><br>300<br>300<br>300<br>300                                  | <b>Rated AMP</b><br>1041<br>902<br>451<br>361 |
| <b>MOTOR STARTING</b><br>Maximum at 95% instantaneous voltage dip<br>with standard alternator—60 Hz<br>with optional alternator—60 Hz   |  | <b>208/240V</b><br>800 KVA<br>1000 KVA                                 | <b>480V</b><br>1060 KVA<br>1350 KVA          | <b>208/240V</b><br>900 KVA<br>1000 KVA                                 | <b>480V</b><br>1060 KVA<br>1350 KVA           |
| <b>FUEL</b><br>Fuel consumption—60 Hz—100% Load - ft. <sup>3</sup> /hr.<br>No Load<br>25%<br>50%<br>75%<br>100%   |  | <b>N.G.</b><br>906<br>1557<br>2253<br>3000<br>3792                     |  | <b>N.G.</b><br>906<br>1671<br>2376<br>3189<br>4100                     |   |
| <b>COOLING</b><br>Coolant capacity System lit. (US gal.)<br>Coolant flow/min. 60 Hz US gal.<br>Heat rejection to coolant BTU/hr.<br>Inlet air 60 Hz (cfm)<br>Max. operating air temp. onto radiator °C (°F)<br>Max. operating ambient temp. °C (°F)<br>Max. external pressure drop on rad. in. H <sub>2</sub> O |  | 56.9 (15)<br>138<br>1,046,600<br>19,200<br>60 (140)<br>50 (122)<br>0.5 |  | 56.9 (15)<br>139<br>1,048,250<br>19,200<br>60 (140)<br>50 (122)<br>0.5 |   |
| <b>COMBUSTION AIR REQUIREMENTS</b><br>Flow at rated power 60 Hz m <sup>3</sup> /min. (cfm)  |  | 31.1 (1100)  |  | 34 (1200)  |   |
| <b>EXHAUST</b><br>Exhaust flow at rated output 60 Hz m <sup>3</sup> /min. (cfm)<br>Max. recommended back pressure Kpa (Hg)<br>Exhaust temp. at rated output °F<br>Exhaust outlet size (flange)  |  | 112 (3960)<br>5.0 (1.5")<br>1470<br>4" I.D.                            |  | 122 (4335)<br>5.0 (1.5")<br>1480<br>4" I.D.                            |   |
| <b>ENGINE</b><br>Rated RPM 60 Hz<br>HP at rated KW 60 Hz<br>Piston speed 60 Hz mm/min. (ft./min.)<br>BMEP 60 Hz   |  | 2900<br>419<br>580 (2285)<br>178                                       |  | 2900<br>454<br>580 (2285)<br>183                                       |   |
| <b>DERATION FACTORS</b><br>Temperature<br>1.8% for every 10°C above - °C<br>1.1% for every 10°F above - °F<br>Altitude<br>0.7% for every 100 m above - m<br>2.1% for every 1000 ft. above - ft.   |  | 40<br>104<br>1220<br>4000  |  | 40<br>104<br>1067<br>3500  |   |

## STANDARD ENGINE & SAFETY FEATURES

SG275/SG300

- High Coolant Temperature Automatic Shutdown
- Low Coolant Level Automatic Shutdown
- Low Oil Pressure Automatic Shutdown
- Overspeed Automatic Shutdown (Solid-state)
- Crank Limiter (Solid-state)
- Oil Drain Extension
- Radiator Drain Extension
- Factory-Installed Cool Flow Radiator
- Closed Coolant Recovery System
- UV/Ozone Resistant Hoses
- Rubber-Booted Engine Electrical Connections
- Isochronous Governor
- Fuel Lockoff Solenoid
- Secondary Fuel Regulator (N.G.)
- Stainless Steel Flexible Exhaust Connection
- Battery Charge Alternator
- Battery Cables
- Battery Tray
- Vibration Isolation of Unit to Mounting Base
- 24 Volt, Solenoid-Activated Starter Motor
- Air Cleaner
- Fan Guard
- Control Console (H100)

## OPTIONS

- **OPTIONAL COOLING SYSTEM ACCESSORIES**
  - Radiator Dust Adapter
- **OPTIONAL FUEL ACCESSORIES**
  - Flexible Fuel Lines
- **OPTIONAL EXHAUST ACCESSORIES**
  - Critical Exhaust Stencil
- **OPTIONAL ELECTRICAL ACCESSORIES**
  - Battery, (2) - 12 Volt, 135 A.H., 4DLT
  - Battery, (2) - 12 Volt, 225 A.H., 9D
  - Battery Heater
  - 2A Battery Charger
  - 10A Dual Rate Battery Charger
- **OPTIONAL ALTERNATOR ACCESSORIES**
  - Alternator Strip Heater
  - Alternator Tropicalization
  - Main Line Circuit Breaker
- **CONTROL CONSOLE OPTIONS**
  - Digital Controller H100 see specification 0772170SBY
- **ADDITIONAL OPTIONAL EQUIPMENT**
  - Automatic Transfer Switch (ATS or HTS)
  - 20 Light Remote Annunciator
  - Remote Relay Panels
  - Unit Vibration Isolators
  - Oil Make-Up System
  - Oil Heater
  - 5 Year Warranty
  - Export Boating
  - GenLink® Communications Software
- **OPTIONAL ENCLOSURES**
  - Weather Protective
  - Sound Attenuated
  - Aluminum and Stainless Steel
  - Enclosed Muffler

Distributed by:

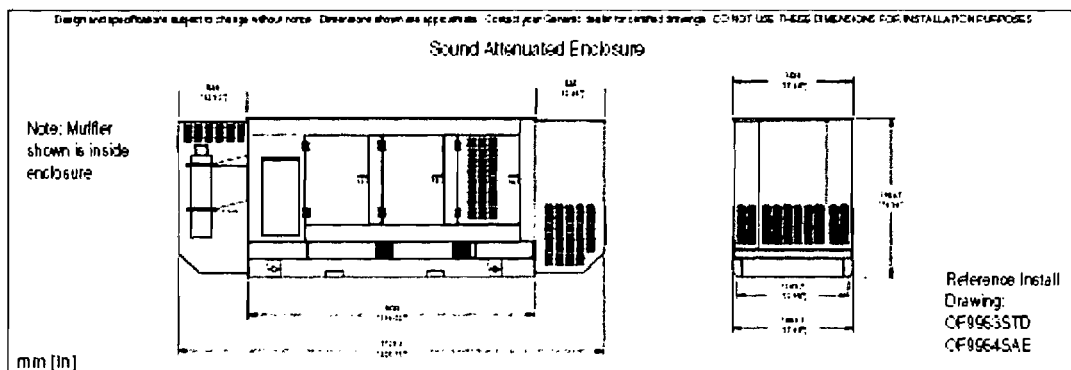

**GENERAC** POWER SYSTEMS, INC. • P.O. BOX 8 • WAUKESHA, WI 53187

262/544-4811 • FAX 262/544-4851

Bulletin 01735408BY • Printed in USA 04 07

© 2007 Generac Power Systems, Inc. All rights reserved. All specifications subject to change without notice.

**Attachment F**  
**Emission Calculations**

**Compressor Station No. 26**

**Engine No. 2603 EPN: 003**

**NOx Emissions: (Based on Vendor Data)**

$$\text{lb NOx/hr} = 8.52$$

$$\begin{aligned} \text{tons NOx/yr} &= (\text{lb NOx/hr})(2000 \text{ lb/1 ton})(8760 \text{ hr/1 yr}) \\ &= (8.52 \text{ lb/hr})(2000 \text{ lb/1 ton})(8760 \text{ hr/yr}) \\ &= 37.318 \end{aligned}$$

**CO Emissions: (Based on Vendor Data)**

$$\text{lb CO/hr} = 8.64$$

$$\begin{aligned} \text{tons CO/yr} &= (\text{lb CO/hr})(2000 \text{ lb/1 ton})(8760 \text{ hr/1 yr}) \\ &= (8.64 \text{ lb/hr})(2000 \text{ lb/1 ton})(8760 \text{ hr/yr}) \\ &= 37.843 \end{aligned}$$

**VOC Emissions: (Based on Vendor Data)**

$$\text{lb UHC/hr} = 4.950$$

$$\begin{aligned} \text{lb VOC/yr} &= (0.495 \text{ UHC lb/hr}) * (\text{VOC fraction of } 0.1) \\ &= 0.495 \end{aligned}$$

$$\begin{aligned} \text{tons VOC/yr} &= (\text{lb VOC/hr})(2000 \text{ lb/1 ton})(8760 \text{ hr/1 yr}) \\ &= (0.50 \text{ lb/hr})(2000 \text{ lb/1 ton})(8760 \text{ hr/yr}) \\ &= 2.168 \end{aligned}$$

**SO2 Emissions: (Based on FERC Limits)**

$$\begin{aligned} \text{lb S/hr} &= (\text{gr S/100 scf})(\text{MMscf/hr})(1 \text{ lb/7000 gr}) \\ &= (10 \text{ gr S/100 scf})(0.1518 \text{ MMscf/hr})(1 \text{ lb/7000 gr}) \\ &= 2.169 \end{aligned}$$

$$\begin{aligned} \text{lb SO2/hr} &= (\text{lb S/hr})(2 \text{ lb SO2/lb S}) \\ &= (2.17 \text{ lb S/hr})(2 \text{ lb SO2/lb S}) \\ &= 4.338 \end{aligned}$$

$$\begin{aligned} \text{tons SO2/yr} &= (\text{lb SO2/hr})(\text{hr/yr})(1 \text{ ton/2000 lb}) \\ &= (4.34 \text{ lb SO2/hr})(8760 \text{ hr/yr})(1 \text{ ton/2000 lb}) \\ &= 18.999 \end{aligned}$$

**PM 10/2.5 Emissions: (Based on AP-42 Table 3.1-2a, 4/00)**

$$\begin{aligned} \text{lb PM/hr} &= (\text{lb PM/MMBtu})(\text{MMBtu/hr}) \\ &= (0.0066 \text{ lb/MMBtu})(157.89 \text{ MMBtu/hr}) \\ &= 1.042 \end{aligned}$$

$$\begin{aligned} \text{tons PM/yr} &= (\text{lb PM/hr})(\text{hr/yr})(1 \text{ ton/2000 lb}) \\ &= (1.04 \text{ lb PM/hr})(8760 \text{ hr/yr})(1 \text{ ton/2000 lb}) \\ &= 4.564 \end{aligned}$$

**HAPs Emissions: (Based on AP-42 Table 3.1-3, 4/00)**

$$\begin{aligned} \text{lb HAP/hr} &= (\text{lb HAP/MMBtu})(\text{MMBtu/hr}) \\ &= (0.00102700 \text{ lb/MMBtu})(157.890 \text{ MMBtu/hr}) \\ &= 0.162 \end{aligned}$$

$$\begin{aligned} \text{tons HAP/yr} &= (\text{lb HAP/hr})(\text{hr/yr})(1 \text{ ton/2000 lb}) \\ &= (0.162 \text{ lb HAP/hr})(8760 \text{ hr/yr})(1 \text{ ton/2000 lb}) \\ &= 0.710 \end{aligned}$$

### Emergency Gen. Nos. 3 & 4 EPNs:

#### NOx Emissions: (Based on Vendor Data)

$$\begin{aligned} \text{lb NOx/hr} &= (\text{g/bhp-hr})(\text{bhp})(1 \text{ lb}/453.59 \text{ g}) \\ &= (2.12 \text{ g/bhp-hr})(454 \text{ bhp})(1 \text{ lb}/453.59 \text{ g}) \\ &= 2.122 \\ \text{Control Effic.} &= 5.7\% \\ \text{Controlled NOx lb/hr} &= 2.00 \\ \\ \text{tons NOx/yr} &= (\text{lb NOx/hr})(\text{hr/yr})(1 \text{ ton}/2000 \text{ lb}) \\ &= (2.12 \text{ lb NOx/hr})(100 \text{ hr/yr})(1 \text{ ton}/2000 \text{ lb}) \\ &= 0.1061 \\ \text{Control Effic.} &= 5.7\% \\ \text{Controlled NOx tpy} &= 0.10 \end{aligned}$$

#### CO Emissions: (Based on Vendor Data)

$$\begin{aligned} \text{lb CO/hr} &= (\text{g/bhp-hr})(\text{bhp})(1 \text{ lb}/453.59 \text{ g}) \\ &= (118.3 \text{ g/bhp-hr})(454 \text{ bhp})(1 \text{ lb}/453.59 \text{ g}) \\ &= 118.404 \\ \text{Control Effic.} &= 96.6\% \\ \text{Controlled CO lb/hr} &= 4.03 \\ \\ \text{tons CO/yr} &= (\text{lb CO/hr})(\text{hr/yr})(1 \text{ ton}/2000 \text{ lb}) \\ &= (118.40 \text{ lb CO/hr})(100 \text{ hr/yr})(1 \text{ ton}/2000 \text{ lb}) \\ &= 5.92 \\ \text{Control Effic.} &= 96.6\% \\ \text{Controlled CO tpy} &= 0.20 \end{aligned}$$

#### VOC Emissions: (Based on Vendor Data)

$$\begin{aligned} \text{lb VOC/hr} &= (\text{g/bhp-hr})(\text{bhp})(1 \text{ lb}/453.59 \text{ g}) \\ &= (0.29 \text{ g/bhp-hr})(454 \text{ bhp})(1 \text{ lb}/453.59 \text{ g}) \\ &= 0.290 \\ \text{Control Effic.} &= 0\% \\ \text{Controlled VOC lb/hr} &= 0.290 \\ \\ \text{tons VOC/yr} &= (\text{lb VOC/hr})(\text{hr/yr})(1 \text{ ton}/2000 \text{ lb}) \\ &= (0.29 \text{ lb VOC/hr})(100 \text{ hr/yr})(1 \text{ ton}/2000 \text{ lb}) \\ &= 0.0145 \\ \text{Control Effic.} &= 0\% \\ \text{Controlled CO tpy} &= 0.0145 \end{aligned}$$

#### SO2 Emissions: (Based on FERC Limits)

$$\begin{aligned} \text{lb S/hr} &= (\text{gr S}/100 \text{ scf})(\text{MMscf/hr})(1 \text{ lb}/7000 \text{ gr}) \\ &= (10 \text{ gr S}/100 \text{ scf})(0.0041 \text{ MMscf/hr})(1 \text{ lb}/7000 \text{ gr}) \\ &= 0.059 \\ \\ \text{lb SO2/hr} &= (\text{lb S/hr})(2 \text{ lb SO2}/\text{lb S}) \\ &= (0.06 \text{ lb S/hr})(2 \text{ lb SO2}/\text{lb S}) \\ &= 0.117 \\ \\ \text{tons SO2/yr} &= (\text{lb SO2/hr})(\text{hr/yr})(1 \text{ ton}/2000 \text{ lb}) \\ &= (0.117 \text{ lb SO2/hr})(100 \text{ hr/yr})(1 \text{ ton}/2000 \text{ lb}) \\ &= 0.006 \end{aligned}$$

#### PM Emissions: (Based on AP-42 Table 3.2-3, 7/00)

$$\begin{aligned} \text{lb PM/hr} &= (\text{lb PM/MMBtu})(\text{MMBtu/hr}) \\ &= (0.01941 \text{ MMBtu/hr})(4.26 \text{ MMBtu/hr}) \\ &= 0.083 \\ \\ \text{tons PM/yr} &= (\text{lb PM/hr})(\text{hr/yr})(1 \text{ ton}/2000 \text{ lb}) \\ &= (0.083 \text{ lb PM/hr})(100 \text{ hr/yr})(1 \text{ ton}/2000 \text{ lb}) \\ &= 0.0041 \end{aligned}$$

#### HAPs Emissions: (Based on AP-42 Table 3.2-3, 7/00)

$$\begin{aligned} \text{lb HAP/hr} &= (\text{lb HAP/MMBtu})(\text{MMBtu/hr}) \\ &= (0.0234 \text{ lb/MMBtu})(4.26 \text{ MMBtu/hr}) \\ &= 0.0997 \\ \\ \text{tons HAP/yr} &= (\text{lb HAP/hr})(\text{hr/yr})(1 \text{ ton}/2000 \text{ lb}) \\ &= (0.10 \text{ lb HAP/hr})(100 \text{ hr/yr})(1 \text{ ton}/2000 \text{ lb}) \\ &= 0.005 \end{aligned}$$

**TANKS 4.0.9d**  
**Emissions Report - Summary Format**  
**Tank Identification and Physical Characteristics**

**Identification**

User Identification: FGT CS 26 Oily Water  
 City: Lecanto  
 State: Florida  
 Company: Florida Gas Transmission  
 Type of Tank: Vertical Fixed Roof Tank  
 Description:

**Tank Dimensions**

Shell Height (ft): 6.00  
 Diameter (ft): 4.00  
 Liquid Height (ft) : 6.00  
 Avg. Liquid Height (ft): 3.00  
 Volume (gallons): 564.02  
 Turnovers: 0.89  
 Net Throughput(gal/yr): 500.00  
 Is Tank Heated (y/n): N

**Paint Characteristics**

Shell Color/Shade: White/White  
 Shell Condition: Good  
 Roof Color/Shade: White/White  
 Roof Condition: Good

**Roof Characteristics**

Type: Cone  
 Height (ft) 0.00  
 Slope (ft/ft) (Cone Roof) 0.06

**Breather Vent Settings**

Vacuum Settings (psig): -0.03  
 Pressure Settings (psig) 0.03

Meteorological Data used in Emissions Calculations: Gainesville, Florida (Avg Atmospheric Pressure = 14.75 psia)

**TANKS 4.0.9d**  
**Emissions Report - Summary Format**  
**Liquid Contents of Storage Tank**

**FGT CS 26 Oily Water - Vertical Fixed Roof Tank**  
**Lecanto, Florida**

| Mixture/Component | Month | Daily Liquid Surf. Temperature (deg F) |      |      | Liquid Bulk Temp (deg F) | Vapor Pressure (psia) |      |      | Vapor Mol. Weight | Liquid Mass Fract. | Vapor Mass Fract. | Mol. Weight | Basis for Vapor Pressure Calculations |
|-------------------|-------|--|------|------|--------------------------|-----------------------|------|------|-------------------|--------------------|-------------------|-------------|---------------------------------------|
|                   |       | Avg.                                   | Min. | Max. |                          | Avg.                  | Min. | Max. |                   |                    |                   |             |                                       |

**TANKS 4.0.9d**  
**Emissions Report - Summary Format**  
**Individual Tank Emission Totals**

**Emissions Report for: Annual**

**FGT CS 26 Oily Water - Vertical Fixed Roof Tank**  
**Lecanto, Florida**

| Components | Losses(lbs)  |                |                 |
|------------|--------------|----------------|-----------------|
|            | Working Loss | Breathing Loss | Total Emissions |
| Lube Oil   | 0.00         | 0.00           | 0.00            |



**TANKS 4.0.9d**  
**Emissions Report - Summary Format**  
**Tank Identification and Physical Characteristics**

**Identification**

User Identification: FGT CS 26 Condensate  
 City: Lecanto  
 State: Florida  
 Company: Florida Gas Transmission  
 Type of Tank: Vertical Fixed Roof Tank  
 Description:

**Tank Dimensions**

Shell Height (ft): 12.00  
 Diameter (ft): 8.00  
 Liquid Height (ft) : 12.00  
 Avg. Liquid Height (ft): 6.00  
 Volume (gallons): 4,512.16  
 Turnovers: 0.11  
 Net Throughput(gal/yr): 500.00  
 Is Tank Heated (y/n): N

**Paint Characteristics**

Shell Color/Shade: White/White  
 Shell Condition: Good  
 Roof Color/Shade: White/White  
 Roof Condition: Good

**Roof Characteristics**

Type: Cone  
 Height (ft) 0.00  
 Slope (ft/ft) (Cone Roof) 0.06

**Breather Vent Settings**

Vacuum Settings (psig): -0.03  
 Pressure Settings (psig) 0.03

Meteorological Data used in Emissions Calculations: Gainesville, Florida (Avg Atmospheric Pressure = 14.75 psia)

**TANKS 4.0.9d**  
**Emissions Report - Summary Format**  
**Liquid Contents of Storage Tank**

**FGT CS 26 Condensate - Vertical Fixed Roof Tank**  
**Lecanto, Florida**

| Mixture/Component   | Month | Daily Liquid Surf. Temperature (deg F) |       |       | Liquid Bulk Temp (deg F) | Vapor Pressure (psia) |        |        | Vapor Mol. Weight | Liquid Mass Fract. | Vapor Mass Fract. | Mol. Weight | Basis for Vapor Pressure Calculations |
|---------------------|-------|--|-------|-------|--------------------------|-----------------------|--------|--------|-------------------|--------------------|-------------------|-------------|---------------------------------------|
|                     |       | Avg.                                   | Min.  | Max.  |                          | Avg.                  | Min.   | Max.   |                   |                    |                   |             |                                       |
| Pipeline Condensate | All   | 70.52                                  | 64.81 | 76.23 | 68.60                    | 0.6513                | 0.5658 | 0.7473 | 53.0000           |                    |                   | 53.00       | Option 4: RVP=1.4                     |

**TANKS 4.0.9d**  
**Emissions Report - Summary Format**  
**Individual Tank Emission Totals**

**Emissions Report for: Annual**

**FGT CS 26 Condensate - Vertical Fixed Roof Tank**  
**Lecanto, Florida**

| Components          | Losses(lbs)  |                |                 |
|---------------------|--------------|----------------|-----------------|
|                     | Working Loss | Breathing Loss | Total Emissions |
| Pipeline Condensate | 0.31         | 28.92          | 29.23           |

## **Attachment G**

### **Fuel Analysis**

BEST AVAILABLE COPY

| FTWSCB1.ener         | East System Chromatographs |                    |                     |                    |                     |                             |                  | 01-Aug-2008 14:05:09 |
|----------------------|----------------------------|--------------------|---------------------|--------------------|---------------------|-----------------------------|------------------|----------------------|
|                      | Station 15<br>CR15         | Station 16<br>BRO1 | Station 18<br>CR18  | Station 19<br>CR19 | Jacksonville<br>Lab | Gainesville<br>Lab          | Brandy<br>Branch | Station<br>21        |
| n-Hexanes +          | 0.0698                     | 0.0706             | 0.0627              | 0.0199             | 0.0058              | 0.0638                      | 0.0013           | 0.0453               |
| Nitrogen             | 0.5661                     | 0.5581             | 0.5374              | 0.4067             | 0.0616              | 0.5267                      | 0.0184           | 0.4515               |
| Methane              | 95.5536                    | 95.5834            | 95.5528             | 95.9043            | 96.5431             | 95.6856                     | 96.6087          | 95.6529              |
| Carbon Dioxide       | 0.9859                     | 0.9896             | 0.9931              | 0.7936             | 0.1266              | 1.0224                      | 0.0153           | 0.7481               |
| Ethane               | 2.2210                     | 2.2010             | 2.2452              | 2.3074             | 2.6850              | 2.1642                      | 2.7702           | 2.4459               |
| Propane              | 0.3579                     | 0.3530             | 0.3637              | 0.3569             | 0.4396              | 0.3325                      | 0.4590           | 0.4177               |
| Iso-Butane           | 0.0806                     | 0.0796             | 0.0814              | 0.0710             | 0.0704              | 0.0728                      | 0.0702           | 0.0854               |
| n-Butane             | 0.0944                     | 0.0933             | 0.0947              | 0.0716             | 0.0563              | 0.0757                      | 0.0515           | 0.0923               |
| Iso-Pentane          | 0.0406                     | 0.0411             | 0.0395              | 0.0270             | 0.0076              | 0.0333                      | 0.0039           | 0.0356               |
| n-Pentane            | 0.0301                     | 0.0304             | 0.0295              | 0.0187             | 0.0038              | 0.0229                      | 0.0016           | 0.0253               |
| Un-normalized Totals | 100.03                     |                    | 99.91               | 99.78              | 100.08              |                             | 99.85            | 99.40                |
| Specific Gravity     | 0.5869                     | 0.5873             | 0.5868              | 0.5831             | 0.5759              |                             | 0.5750           | 0.5850               |
| BTU / cu. ft.        | 1030.2                     |                    | 1030.4              | 1031.8             | 1043.2              |                             | 1045.2           | 1035.1               |
|                      | CR15                       |                    | BRO1                | CR18               | CR19                | GLAB                        | CRBB             | CR21                 |
| Dew Point and H2S    | Recall                     |                    | West Chromatographs |                    |                     | East On Line Chromatographs |                  |                      |

**Attachment H**  
**List of Exempt Emissions Units**

### **List of Exempt Emissions Units**

1. 500 gallon Oily Water Storage Tank, vertical, 4' x 6'
2. 100 barrel Condensate Storage Tank, vertical, 8' x 12'
3. Fugitive emissions from component leaks

LIST FOR NEW APPLICATIONS

Application Facility/Site Name: Florida Gas Transmission Company - Compressor Station No. 29

- Find out which section/Processor: Susan DeVore
- EPSAP Application: Application Number/Version: \_\_\_\_\_
  - Box already selected to display on APDS
- Received Date: 11/26/08
  - Stamped date
  - Special Instructions:

- PSD-FL- N/A
- Log Project: Project Number:

0550060-001-AC

- Have project scanned (return to: Sylvia / Barbara / Elizabeth )
  - Document Date: 11 / 26 / 2008
  - Document Type:
    - Application
    - Correspondence
  - Notes for Scanning Staff:

*155 pgs Scanned: DEC 18 2008*

- Already Scanned (look for it in APDS under air permit/project number)

- Make Folder
- Send Notification e-mail
  - EPA (Katy gets all EPA emailed notifications)
  - Impact Area:
    - NPS
    - FWS
    - GEORGIA
    - Forest Service

*12/22/08*  
 District/Local (look in ARMS for Facility Office)

- Permit Processor
- Final Document Destination – File Sylvia Barbara Elizabeth

0550060-001  
N/A  
11-26-2008

Date Scanned: DEC 18 2008  
Page Count: 155  
Scanned by: K. Carr





# Florida Gas Transmission Company

A Southern Union/El Paso Affiliate

5444 Westheimer Road  
Houston, TX 77056-5306

P.O. Box 4967  
Houston, TX 77210-4967  
713.989.7000

November 26, 2008

*UPS Overnight*

~~CERTIFIED MAIL - RETURN RECEIPT~~

Ms. Trina Vielhauer, Chief  
Bureau of Air Regulation  
Florida Department of Environmental Protection  
2600 Blairstone, MS 5500  
Tallahassee, FL 32399-2400  
Phone: 850-921-9504

RECEIVED

NOV 26 2008

BUREAU OF AIR REGULATION

Reference: New Facility *0550060*  
Compressor Station No. 29, Highlands County

*Project No. : 0550060-001-AC*

Dear Ms. Vielhauer:

**Subject: Application for Air Construction Permit**

Florida Gas Transmission Company (FGT) is proposing to construct a new natural gas pipeline compressor station to be located in Highlands County near Okeechobee. The facility will be identified as Compressor Station No. 29 and will consist of two new 7,800 hp natural gas fired compressor turbines, two 454 natural gas fired emergency generators and supporting equipment.

After construction, the facility will be a minor source under both New Source Review and Title V definitions; therefore, a state only construction permit is required.

Enclosed is an Application with supporting documentation for an Air Construction Permit for the proposed new facility. A processing fee of \$2250.00 is attached.

If you have any questions or need additional information, please call me at (713) 989-7459.

Sincerely,

Charles Wait  
Principal Engineer

CC: Arnold L. Eisenstein  
Frank Diemont  
Kevin McGlynn, P.E.  
Duane Pierce, AQMcS, LLC  
Compressor Station No. 29



# **Application for Air Permit to Construct**

**Florida Gas Transmission Company, LLC  
Phase VIII Expansion Project  
Okeechobee Compressor Station No. 29  
Okeechobee, Highlands County, Florida  
New Facility**

**November 2008**

# AQMcs

---

## Table of Contents

|       |  |    |
|-------|--|----|
| 1.0   | INTRODUCTION.....  | 1  |
| 2.0   | PROJECT DESCRIPTION.....   | 3  |
| 2.1   | <i>Proposed New Sources</i> .....  | 3  |
| 2.1.1 | <i>New Compressor Turbines</i> .....   | 3  |
| 2.2.2 | <i>New Emergency Generators</i> .....  | 6  |
| 2.2.3 | <i>Support Equipment</i> .....   | 6  |
| 2.2.4 | <i>New Storage Tanks</i> .....   | 6  |
| 2.2.5 | <i>Fugitive Emissions</i> .....  | 6  |
| 2.2   | <i>Emissions Summary</i> .....   | 10 |
| 3.0   | REGULATORY ANALYSIS.....   | 12 |
| 3.2   | <i>Federal Regulations Review</i> .....  | 12 |
| 3.1.1 | <i>Classification of Ambient Air quality</i> .....   | 12 |
| 3.1.2 | <i>PSD Applicability</i> .....   | 13 |
| 3.1.3 | <i>Non-attainment New Source Review (NNSR) Applicability</i> .....                               | 15 |
| 3.1.4 | <i>Applicability of New source Performance Standards (NSPS)</i> .....                            | 15 |
| 3.1.5 | <i>Applicability of National Emission Standards for Hazardous Air Pollutants (NESHAPS)</i> ..... | 17 |
| 3.1.6 | <i>Applicability of Title V</i> .....  | 17 |
| 3.2   | <i>Florida State Air Quality Regulations</i> .....   | 18 |
| 3.2.1 | <i>Rule 62-210.300 Permits Required</i> .....  | 18 |
| 3.2.2 | <i>Rule 62-204.240 Ambient Air Quality Standards</i> .....                                       | 18 |
| 3.2.3 | <i>Rule 62-296.320(2) Objectionable Odors</i> .....  | 18 |
| 3.2.4 | <i>Rule 62-296.320(4)(b)1 General Particulate Emission Limiting Standards</i> .....              | 18 |
| 4.0   | REFERENCES.....  | 19 |

|              |   |
|--------------|---|
| Attachment A | DEP Forms   |
| Attachment B | Process Flow Diagram  |
| Attachment C | Precautions to Prevent Emissions of Unconfined Particulate Matter |
| Attachment D | Plot Plan   |
| Attachment E | Vendor Information  |
| Attachment F | Calculations  |
| Attachment G | Fuel Analysis   |
| Attachment H | Exempt Sources List   |

# AQMcs

---

## List of Tables

|   |    |
|---|----|
| Table 2-1 Proposed New Turbine (2901 and 2902) Specifications and Stack Parameters..          | 4  |
| Table 2-2 Proposed New Turbine (2901/2902) Compressor Engine Emissions.....                   | 5  |
| Table 2-3 Proposed Emergency Generator Engines Specifications and Stack Parameters            | 7  |
| Table 2-4 Emissions from Each Proposed Generator Engine .....                                 | 8  |
| Table 2-5 New Storage Tanks for Compressor Station No. 29.....                                | 9  |
| Table 2-6 VOC Fugitive Emission Calculations and Summary .....                                | 10 |
| Table 2-7 Potential Annual Emissions (tpy) Summary .....                                      | 11 |
| Table 3-1 National and State Ambient Air Quality Standards ( $\mu\text{g}/\text{m}^3$ ) ..... | 13 |
| Table 3-2 Applicability of PSD Significant Emission Rates .....                               | 14 |
| Table 3-3 Applicability of New Source Performance Standards Subpart KKKK .....                | 16 |
| Table 3-4 Applicability of New Source Performance Standards Subpart JJJJ.....                 | 17 |

## List of Figures

|                              |   |
|------------------------------|---|
| Figure 1-1 Location Map..... | 2 |
|------------------------------|---|

## 1.0 INTRODUCTION

Florida Gas Transmission Company (FGT) is proposing to construct a new natural gas pipeline facility near Okeechobee, in Highlands County, Florida (Compressor Station No. 29). This proposed modification is part of FGT's Phase VIII Expansion Project, aimed at increasing the supply capacity of FGT's network servicing domestic suppliers, commercial, and industrial customers in Florida. The scope of work for the Phase VIII Expansion Project includes expansion through the addition of state-of-the-art compressor engines at nine existing compressor stations within the States of Florida and Alabama. Three compressor stations within Florida will receive electric driven turbine compressors and five compressor stations within Florida will receive natural gas-fired turbine compressors.

The new Compressor Station No. 29 will be located approximately 13 miles west of U.S. Highway 441 on State Highway 70. Figure 1-1 shows the location of the existing compressor station.

The proposed new facility will consist of two new 7,800 hp natural gas fired compressor turbines, two 454 natural gas fired emergency generators and supporting equipment. The turbines will be Solar Taurus 60-7800S units and will be used solely for transporting natural gas by pipeline for distribution to markets in Florida.

Additionally, FGT is also proposing to install two emergency generators at this facility. Each of the two new generators will be powered by a 454 bhp, gas-fired reciprocating compressor engine which will meet the new 40 CFR Subpart JJJJ standards.

Based on projected new annual emission rates, the proposed facility would have NO<sub>x</sub> potential emissions of 53.2 tpy and CO potential emissions of 64.8 tpy; therefore, this new facility will not constitute a major new source under Prevention of Significant Deterioration (PSD) regulations. A state only construction permit is required.

This narrative contains three additional sections. Descriptions of the proposed engines and emergency generators are presented in Section 2.0. The air quality review requirements and applicability of state and federal regulations are discussed in Section 3.0. References are included in Section 4.0. FDEP permit application forms are provided in Attachment A. Attachment B contains a process flow diagram, Attachment C contains Precautions to Prevent Emissions of Unconfined Particulate Matter, Attachment D contains a plot plan of the facility and Attachment E provides vendor information a description of the sampling platform. Attachment F provides emission calculations; Attachment G has a fuel analysis and Attachment H a list of exempt sources.

Figure 1-1 Location Map

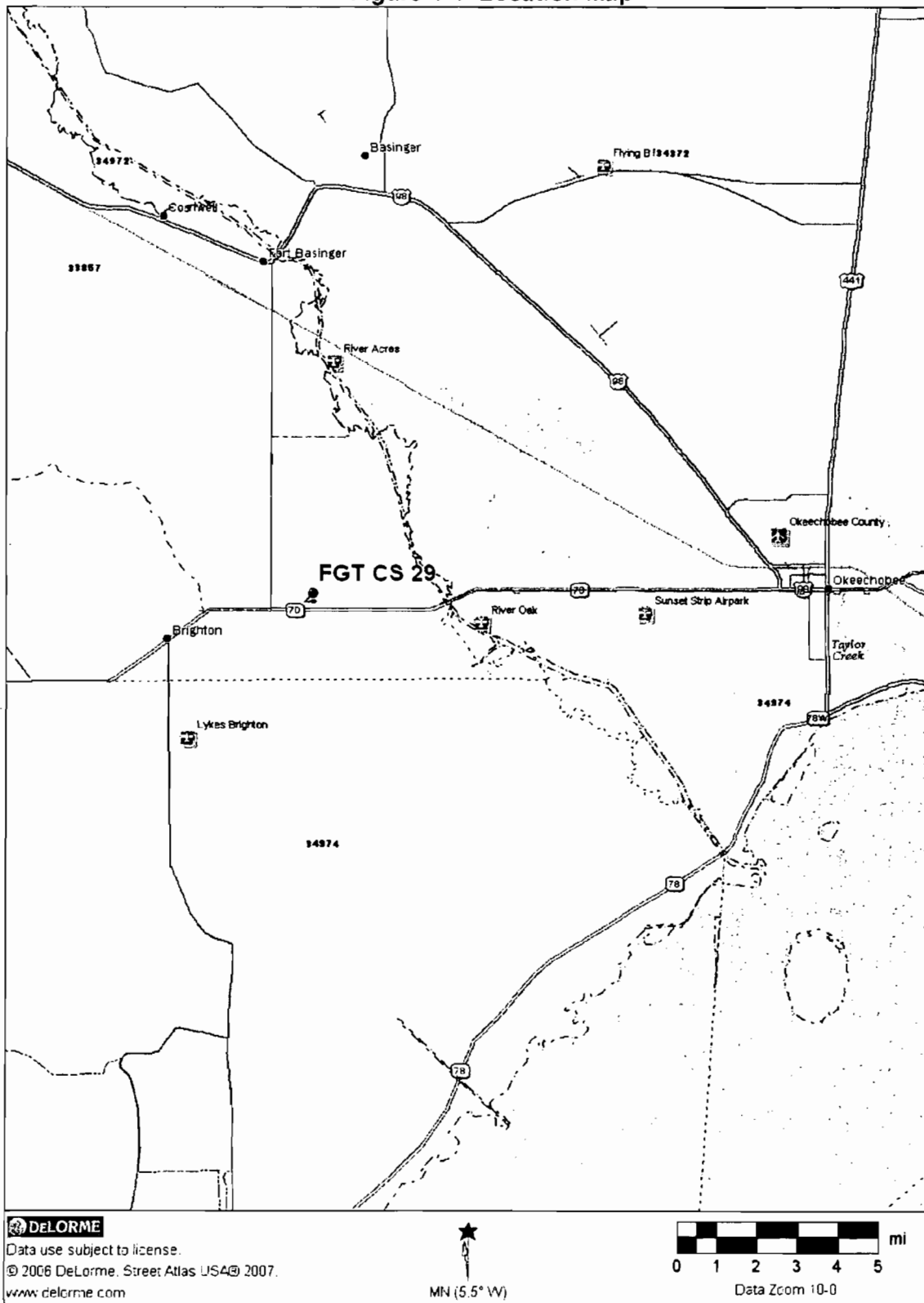

## **2.0 PROJECT DESCRIPTION**

A plot plan of FGT's Compressor Station No. 29, showing the location of the plant boundaries, and the location of the new turbines and generators is presented in Attachment D. The following sections provide a description of the existing operations at this location, as well as a description of the proposed project.

### **2.1 Proposed New Sources**

FGT proposes to install two new gas-fired turbines (Compressor Engines 2901 and 2902). The new engines will be used to increase the volumetric delivery capacity by driving a gas compressor that is a part of a gas transmission line that transports natural gas from source wells in Texas and Louisiana for delivery throughout Florida. Without the proposed modifications, it would not be possible to increase the volumetric delivery capacity necessary to meet both short and long-term demands for natural gas in Florida.

In addition, as part of the project, two new emergency generators will be installed. Each will be powered by a 454 bhp, gas-fired, 4-stroke, rich burn reciprocating compressor engine equipped with emissions that will be controlled to meet the new 40 CFR Subpart JJJJ standards as required. Details of the changes are described in the following sections.

#### **2.1.1 New Compressor Turbines**

The new turbine compressor engines are Solar Titan 60 -78200S turbine compressor units rated at 7,800 bhp (ISO). Fuel will be exclusively natural gas from FGT's natural gas pipeline. Engine specifications and stack parameters for the proposed engine are presented in Table 2-1.



**Table 2-1 Proposed New Turbine (2901 and 2902) Specifications and Stack Parameters**

| Parameter  | Design                       |
|--|------------------------------|
| Compressor Engine  | 2901/2902                    |
| Type   | Gas Turbine                  |
| Manufacturer   | Solar                        |
| Model  | Taurus 60 - 7800S            |
| Net Output (ISO with inlet and exhaust losses of 4.0 inches H <sub>2</sub> O)  | 7,277 bhp                    |
| Specific Heat Input (LHV) <sup>a</sup>   | 8,326 Btu/hp-hr              |
| Specific Heat Input (HHV) <sup>b</sup>   | 9,220 Btu/hp-hr              |
| Fuel Flow (LHV) <sup>a</sup>   | 60.59 MM Btu/hr              |
| Fuel Flow (HHV) <sup>a</sup>   | 67.09 MM Btu/hr              |
| Maximum Fuel Consumption <sup>c</sup>  | 0.0645 MMscf/hr              |
| Driven Equipment Speed   | 13,854 rpm                   |
| Stack Parameters   |                              |
| Stack Height   | 55 ft                        |
| Stack Diameter   | 6 ft                         |
| Exhaust Gas Flow   | 170,003 lb/h<br>101,546 acfm |
| Exhaust Temperature  | 956 °F                       |
| Exhaust Gas Velocity   | 59.9 ft/sec                  |
| <p>NOTE:</p> <p>acfm = actual cubic feet per minute.</p> <p>bhp = brake horsepower.</p> <p>Btu/hp-hr = British thermal units per brake horsepower per hour.</p> <p>°F = degrees Fahrenheit.</p> <p>ft = feet.</p> <p>ft/sec = feet per second.</p> <p>MMscf/hr = million standard cubic feet per hour.</p> <p>rpm = revolutions per minute.</p> <p><sup>a</sup> Based on vendor provided lower heat rate value (LVH) of 8,326 Btu/hp-hr, a lower heating value of 939.2 Btu/scf and</p> <p><sup>b</sup> Based on natural gas with a HHV of 1040 British thermal units per standard cubic foot (Btu/scf).</p> <p><sup>c</sup> While producing 7,227 bhp and with gas having HHV of 1040 Btu/scf</p> |                              |

Hourly and annual emissions of regulated pollutants from the proposed new turbines at ISO conditions with inlet and exhaust losses are presented in Table 2-2. Emissions of oxides of nitrogen (NO<sub>x</sub>), carbon monoxide (CO) and non-methane hydrocarbons (NMHC) or volatile organic compounds (VOC) are based on the engine manufacturer's supplied data (See Attachment C). These values are based on ISO conditions. Other factors such as ambient temperature can affect these rates.

Typically, turbine vendors do not provide information on particulate matter (PM), sulfur dioxide (SO<sub>2</sub>) or hazardous air pollutant (HAP) emissions; therefore, PM and HAP emissions are based upon USEPA publication AP-42 Section 3.1 (USEPA, 2000). Emissions of SO<sub>2</sub> are based on FGT's Federal Energy Regulatory Commission (FERC) certificate limit of 10 grains sulfur per 100 cubic feet of natural gas.

**Table 2-2 Proposed New Turbine (2901/2902) Compressor Engine Emissions**

| Pollutant                                    | Emission Factor      | Reference           | lb/hr | TPY   |
|--|----------------------|---------------------|-------|-------|
| Nitrogen Oxides <sup>a</sup>                 | 6.04 lb/hr           | Manufacturer Data   | 6.04  | 26.46 |
| Carbon Monoxide <sup>a</sup>                 | 7.35 lb/hr           | Manufacturer Data   | 7.35  | 32.19 |
| Volatile Organic <sup>a,b</sup><br>Compounds | 0.21 lb/hr           | Manufacturer Data   | 0.21  | 0.92  |
| Particulate Matter <sup>c</sup>              | 0.0066 lb/MMBtu      | AP-42, Table 3.1-2a | 0.44  | 1.94  |
| Sulfur Dioxide <sup>c</sup>                  | 10 grains/100 scf    | FERC Limit          | 1.84  | 8.07  |
| HAPS <sup>c</sup>                            | 0.001027<br>lb/MMBtu | AP-42, Table 3.1-2a | 0.07  | 0.30  |

<sup>a</sup> Emissions based on vendor provided values at ISO conditions and inlet and exhaust losses at 4" of H<sub>2</sub>O.

<sup>b</sup> Assumes that VOCs are 10% of THC

<sup>c</sup> Emissions based on vendor provided heat rate at higher heating value.

### **2.2.2 New emergency Generators**

The new generators will be powered by natural gas fueled, rich burn Generac Model SG300 rated at 300 kW (454 bhp). Engine specifications and stack parameters for the proposed engines are presented in Table 2-3 and emissions are presented in Table 2-4.

### **2.2.3 Support Equipment**

In addition to the compressor engine, some support equipment and structures will be installed at the site. They include:

- Two compressor buildings
- An auxiliary building
- A control building

The locations of the structures are shown on the facility plot plan contained in Attachment D. The compressor buildings, each housing a new turbine, have approximate dimensions of 52 feet wide by 64 feet long by 26 feet high. The approximate dimensions of the auxiliary building will be 32 feet wide by 96 feet long by 14 feet high and the approximate dimensions of the control building will be 14 feet wide by 55 feet long by 12 feet high.

### **2.2.4 New Storage Tanks**

Two new storage tanks will be installed at Compressor Station No. 29. The tanks are a 500 gallon oily water storage tank and a 100 barrel condensate storage tank. Specifications for these tanks are listed in Table 2-5. Emissions were calculated with the U.S EPA's (USEPA) Tank 4.0 D program. Details of the calculations can be found in Attachment F. This emission unit is exempt under Rule 62-210.300(3)(b), F.A.C. These emission units are exempt under Rule 62-210.300(3)(b), F.A.C.

### **2.2.5 Fugitive Emissions**

Potential new emissions from Compressor Station No. 29 also include fugitive emissions from the new valves and flanges that will be in gas service. These fugitive emissions have been estimated using USEPA factors for components in gas service at oil and gas facilities (EPA publication EPA-453/R-95-017, November 1995, "Protocol for Equipment Leak Emission Estimates"). Table 2-6 lists the quantities new components to be added as part of the Phase VIII Expansion Project and an estimate of the fugitive emissions from these sources.

**Table 2-3 Proposed Emergency Generator Engines Specifications and Stack Parameters**

| <b>Parameter</b>              | <b>Design</b>                        |
|-------------------------------|--------------------------------------|
| Compressor Engine             | Gen01/Gen02                          |
| Type                          | Natural Gas, Rich Burn Reciprocating |
| Manufacturer                  | Generac                              |
| Model                         | SG300                                |
| Unit Size                     | 454 bhp                              |
| Heat Input                    | 4.26 MM Btu/hr                       |
| Fuel Consumption <sup>a</sup> | 0.00410 MMscf/h                      |
| Speed                         | 2300 rpm                             |
| Stack Parameters              |                                      |
| Stack Height                  | 20 ft                                |
| Stack Diameter                | 0.67 ft                              |
| Exhaust Gas Flow              | 5,300 lb/hr                          |
| Exhaust Gas Flow              | 2,911 acfm                           |
| Exhaust Temperature           | 1490 °F                              |
| Exhaust Gas Velocity          | 138.85 ft/sec                        |

**NOTE:**

acfm = actual cubic feet per minute.  
 bhp = brake horsepower.  
 Btu/hr = British thermal units per hour.  
 °F = degrees Fahrenheit.  
 ft = feet.  
 ft/sec = feet per second.  
 Lb/hr = pound per hour.  
 rpm = revolutions per minute.  
 scf/h = standard cubic feet per hour

<sup>a</sup> Based on heating value for natural gas of 1040 British thermal units per standard cubic foot (Btu/scf).

**Table 2-4 Emissions from Each Proposed Generator Engine**

| Pollutant                    | Uncontrolled      |                    |                     | Controlled        |        |                     | Reference          |
|------------------------------|-------------------|--------------------|---------------------|-------------------|--------|---------------------|--------------------|
|                              | Emission Factor   | lb/hr <sup>a</sup> | TPY <sup>a, b</sup> | Emission Factor   | lb/hr* | TPY <sup>a, b</sup> |                    |
| Nitrogen Oxides              | 2.12 g/hp-hr      | 2.12               | 0.11                | 2.0 g/hp-hr       | 2.00   | 0.109               | NSPS               |
| Carbon Monoxide              | 118.3 g/hp-hr     | 118.41             | 5.92                | 4.0 g/hp-hr       | 4.03   | 0.20                | NSPS               |
| Volatile Organic Compounds** | 0.29 g/hp-hr      | 0.29               | 0.01                | 0.29 g/hp-hr      | 0.29   | 0.01                | NSPS               |
| Particulate Matter           | 0.01941 lb/MMBtu  | 0.083              | <0.01               | 0.01941 lb/MMBtu  | 0.083  | <0.01               | AP-42, Table 3.2-3 |
| Sulfur Dioxide               | 10 grains/100 scf | 0.117              | 0.01                | 10 grains/100 scf | 0.117  | 0.01                | FERC Limit         |
| Hazardous Air Pollutants     | 0.0234 lb/MMBtu   | 0.10               | 0.01                | 0.0234 lb/MMBtu   | 0.10   | 0.01                | AP-42, Table 3.2-3 |

- a. The manufacturer has not finalized design at this time. Actual values may be lower.
- b. Based on 454 bhp, 100 hours of operation per year
- c. assumed VOC 10% of UHC/THC

**Table 2-5 New Storage Tanks for Compressor Station No. 29**

| <b>Tank Name</b>                 | <b>Condensate Tank</b> | <b>Oily Water Tank</b>                |
|----------------------------------|------------------------|---------------------------------------|
| <b>Type of Tank</b>              | Vertical, Cone Roof    | Vertical, Cone Roof                   |
| <b>Contents</b>                  | Hydrocarbon Liquids    | Drain water from washings; oily water |
| <b>Dimensions</b>                | 8' dia x 12' high      | 4' dia x 6' high                      |
| <b>Capacity</b>                  | 100 Barrels            | 500 Gallons                           |
| <b>Paint Color</b>               | White                  | White                                 |
| <b>Maximum Annual Throughput</b> | 50 Gallons             | 100 Barrel                            |
| <b>Pressurized</b>               | No                     | No                                    |
| <b>VOC Emissions (tpy)</b>       | 0.01                   | <0.001                                |

**Table 2-6 VOC Fugitive Emission Calculations and Summary**

| <b>Component</b> | <b>Service</b> | <b>Component</b> | <b>Emissions *</b>         | <b>NM/NE</b>    | <b>Emissions</b> |
|------------------|----------------|------------------|----------------------------|-----------------|------------------|
|                  |                | <b>Count</b>     | <b>Factor<br/>(ton/yr)</b> | <b>Fraction</b> | <b>(ton/yr)</b>  |
| Valves           | Gas            | 86               | 0.0434606                  | 0.05            | 0.1869           |
| Connector        | Gas            | 0                | 0.0019316                  | 0.05            | 0.0000           |
| Flanges          | Gas            | 204              | 0.0037666                  | 0.05            | 0.0384           |
| Open-Ended Line  | Gas            | 0                | 0.0193158                  | 0.05            | 0.0000           |
| Pumps            | Gas            | 0                | 0.023179                   | 0.05            | 0.0000           |
| Other            | Gas            | 0                | 0.0849895                  | 0.05            | 0.0000           |
| Valves           | Light Oil      | 0                | 0.0241448                  | 1.00            | 0.0000           |
| Connector        | Light Oil      | 0                | 0.0020282                  | 1.00            | 0.0000           |
| Flanges          | Light Oil      | 0                | 0.0010624                  | 1.00            | 0.0000           |
| Open-Ended Line  | Light Oil      | 0                | 0.0135211                  | 1.00            | 0.0000           |
| Pumps            | Light Oil      | 0                | 0.1255527                  | 1.00            | 0.0000           |
| Other            | Light Oil      | 0                | 0.0724343                  | 1.00            | 0.0000           |
| Valves           | Heavy Oil      | 0                | 0.0000811                  | 1.00            | 0.0000           |
| Connector        | Heavy Oil      | 0                | 0.0000724                  | 1.00            | 0.0000           |
| Flanges          | Heavy Oil      | 0                | 0.0000038                  | 1.00            | 0.0000           |
| Open-Ended Line  | Heavy Oil      | 0                | 0.0013521                  | 1.00            | 0.0000           |
| Other            | Heavy Oil      | 0                | 0.0002994                  | 1.00            | 0.0000           |
|                  |                |                  |                            | <b>TOTAL:</b>   | <b>0.2253</b>    |

\*EPA publication EPA-453/R-95-017, November 1995, "Protocol for Equipment Leak Emission Estimates"

## 2.2 Emissions Summary

The total changes in emissions resulting from the project are listed on Table 2-7. The calculations used to estimate these emissions are presented in Attachment D.

**Table 2-7 Potential Annual Emissions (tpy) Summary**

| SOURCE ID                                | DESCRIPTION | NO <sub>x</sub> | CO         | VOC <sup>a</sup> | SO <sub>2</sub> | PM         | HAPs       |
|--|-------------|-----------------|------------|------------------|-----------------|------------|------------|
| <b>EXISTING FACILITY</b>                 |             |                 |            |                  |                 |            |            |
|  | None        | 0.0             | 0.0        | 0.0              | 0.0             | 0.0        | 0.0        |
| <b>EXISTING ANNUAL POTENTIAL TOTALS:</b> |             | <b>0.0</b>      | <b>0.0</b> | <b>0.0</b>       | <b>0.0</b>      | <b>0.0</b> | <b>0.0</b> |

| <b>PROPOSED MODIFIED FACILITY</b>        |  |             |             |          |             |            |            |
|--|--|-------------|-------------|----------|-------------|------------|------------|
| 2901                                     | 7,800 bhp Turbine Engine– New            | 26.5        | 32.2        | 0.9      | 8.1         | 1.9        | 0.3        |
| 2903                                     | 7,800 bhp Turbine Engine – New           | 26.5        | 32.2        | 0.9      | 8.1         | 1.9        | 0.3        |
| GEN01                                    | 454 bhp Recip. Engine – New <sup>b</sup> | 0.1         | 0.2         | 0.0      | 0.0         | 0.0        | 0.0        |
| GEN02                                    | 454 bhp Recip. Engine – New <sup>b</sup> | 0.1         | 0.2         | 0.0      | 0.0         | 0.0        | 0.0        |
|  | Other Sources: <sup>c</sup>              | 0.0         | 0.0         | 0.2      | 0.0         | 0.0        | 0.0        |
| <b>PROPOSED ANNUAL POTENTIAL TOTALS:</b> |  | <b>53.2</b> | <b>64.8</b> | <b>2</b> | <b>16.2</b> | <b>3.8</b> | <b>0.6</b> |

|  |  |             |             |          |             |            |            |
|--|--|-------------|-------------|----------|-------------|------------|------------|
| <b>NET CHANGES IN POTENTIAL EMISSIONS:</b> |  | <b>53.2</b> | <b>64.8</b> | <b>2</b> | <b>16.2</b> | <b>3.8</b> | <b>0.6</b> |
|--|--|-------------|-------------|----------|-------------|------------|------------|

|  |   |  |  |  |  |  |  |
|--|---|--|--|--|--|--|--|
|  | (a) VOC = Non-methane/non-ethane hydrocarbons<br>(b) Based on 100 hrs/yr<br>(c) Other Sources Includes ancillary equipment, storage tanks and equipment leaks |  |  |  |  |  |  |
|--|---|--|--|--|--|--|--|



### **3.0 REGULATORY ANALYSIS**

This section presents a review of federal and Florida State air quality regulations, which govern the operations and proposed modifications to be conducted at Compressor Station No. 29.

#### **3.2 Federal Regulations Review**

The federal regulatory programs administered by the USEPA have been developed under the authority of the Clean Air Act. The following subsections review the essential elements of the federal regulatory program and the impact they have on the operations and proposed modifications at Compressor Station No. 29.

##### **3.1.1 Classification of Ambient Air quality**

The 1970 Amendments to the CAA gave the USEPA specific authority to establish the minimum level of air quality that all states would be required to achieve. These minimum values or standards were developed in order to protect the public health (primary) and welfare (secondary). The federally promulgated standards and additional state standards are presented on Table 3-1.

Areas of the country that have air quality equal to or better than these standards (i.e., ambient concentrations less than a standard) are designated as "Attainment Areas", while those where monitoring indicates air quality is worse than the standards are known as "Non-attainment Areas." The designation of an area has particular importance for a proposed project as it determines the type of permit review to which the application will be subject.

Major new sources or major modifications to existing major sources located in attainment areas are required to obtain a PSD permit before initiation of construction. Similar sources located in areas designated as non-attainment or that adversely impact such areas undergo more stringent Non-attainment New Source Review (NNSR). In either case, it is necessary, as a first step, to determine the air quality classification of a project site.

All areas of all states are classified as either attainment, non-attainment or unclassifiable for each criteria pollutant. Highlands County is designated as unclassifiable or attainment for all criteria pollutants. These designations were obtained from 40 CFR 81.310, and 62-204.340 F.A.C.

**BEST AVAILABLE COPY**

**Table 3-1 National and State Ambient Air Quality Standards ( $\mu\text{g}/\text{m}^3$ )**

| POLLUTANT        | AVERAGING PERIOD     | EPA STANDARDS |           | FLORIDA STANDARDS |
|------------------|----------------------|---------------|-----------|-------------------|
|                  |                      | PRIMARY       | SECONDARY |                   |
| PM <sub>10</sub> | 24-hour <sup>1</sup> | 150           | 150       | 150               |
|                  | Annual <sup>2</sup>  | 50            | 50        | 50                |
| SO <sub>2</sub>  | 3-hour <sup>1</sup>  | ---           | 1,300     | 1,300             |
|                  | 24-hour <sup>1</sup> | 365           | ---       | 260               |
|                  | Annual <sup>2</sup>  | 80            | ---       | 60                |
| CO               | 1-hour <sup>1</sup>  | ---           | 40,000    | 40,000            |
|                  | 8-hour <sup>1</sup>  | 10,000        | ---       | 10,000            |
| NO <sub>2</sub>  | Annual <sup>2</sup>  | 100           | 100       | 100               |
| O <sub>3</sub>   | 1-hour <sup>3</sup>  | 235           | 235       | 235               |

1. Not to be exceeded more than once per year.  
2. Never to be exceeded.  
3. Not to be exceeded on more than 3 days over 3 years.

Sources: 40 CFR 50; 36FR22384; Chap. 17-2.300.

The designation of Unclassifiable indicates that there is insufficient monitoring data to prove that the area has attained the federal standards; however, the limited data available indicate that the standard has been achieved. Areas with this classification are treated as attainment areas for permitting purposes. Since Highlands County is considered in attainment for all pollutants, the proposed new emissions are potentially subject to PSD review and not non-attainment review.

### 3.1.2 PSD Applicability

The 1977 CAA Amendments added Part C: Prevention of Significant Deterioration to the Act. This part required proposed new major stationary sources or existing sources planning a major modification in an area that has attained the National AAQS, to conduct a preconstruction review that includes a detailed analysis of the impacts from the source's emissions.

Federal air quality permitting regulations for attainment areas are codified in the Code of Federal Regulations (CFR), Title 40- Protection of the Environment, Part 52.21 - Prevention of Significant Deterioration (40 CFR 52.21). Major revisions to the rules were finalized on December 31, 2002, and became effective on March 3, 2003. State of Florida requirements are located at 62-212.400 F.A.C.

**BEST AVAILABLE COPY**

For the PSD regulations to apply to a given project, the project's potential to emit must constitute a new major stationary source or a major modification to an existing major stationary source. A major stationary source is defined as any of the 28 sources identified in 40 CFR 52.21 that has a potential to emit 100 tons or more per year of any regulated pollutant, or any other stationary source that has the potential to emit 250 tons or more per year of a regulated pollutant. "Potential to emit" is determined on an annual basis after the application of air pollution control equipment, or any other federally enforceable restriction.

"Significant" emission rates are defined as amounts equal to or greater than the emission rates given in Table 3-2.

**Table 3-2 Applicability of PSD Significant Emission Rates**

| <b>Pollutant</b>                                | <b>Emission Rate<br/>Tons/Year</b> |
|---|------------------------------------|
| Carbon Monoxide                                 | 100                                |
| Nitrogen Oxides                                 | 40                                 |
| Sulfur Dioxide                                  | 40                                 |
| Particulate Matter (PM/PM <sub>10</sub> )       | 25/15                              |
| Ozone (VOC)                                     | 40                                 |
| Lead  | 0.6                                |
| Fluorides                                       | 3                                  |
| Reduced Sulfur including Hydrogen Sulfide       | 10                                 |
| Total Reduced Sulfur including Hydrogen Sulfide | 10                                 |
| Sulfuric Acid Mist                              | 7                                  |
| Lead  | 0.6                                |
| Mercury   | 0.1                                |

VOC = Volatile Organic Compounds  
Sources: 40 CFR 52.21(b)(23); Table 212.400-2 62-212 F.A.C.

Proposed project increases for modified sources are determined for each pollutant and are equal to the actual emissions (average of the actual emissions over any 24 month of the ten years immediately prior to the proposed project) subtracted from the proposed future actual emissions. For new sources the emission increase is equal to the potential to emit (PTE) of the source. Fugitive emissions are only included in the potential to emit if the source is one of the 28 named source categories in 40 CFR 52.21(b)(1) or belongs to a stationary source category that is subject to an NSPS proposed prior to August 7, 1980 or that is subject to an NESHAPS promulgated prior to August 7, 1980.

Netting is only required for each regulated pollutant for which the proposed project increases

## BEST AVAILABLE COPY

(decreases are not considered yet) result in a significant increase in emissions. Netting is performed by identifying both the creditable and contemporaneous increases and the reductions in emissions. The contemporaneous period is defined as the period of time from five years prior to the estimated start of construction through estimated start of operation. Since this project does not result in a significant increase, netting is not required.

To summarize, since Compressor Station No. 29 is not one of the 28 named source categories, and the proposed new emissions are not major in themselves, it is not considered a major source or major new source; therefore, the compressor station is not subject to PSD pre-construction review.

### **3.1.3 Non-attainment New Source Review (NNSR) Applicability**

Based on the current non-attainment provisions, all new major stationary sources, or major modifications to such sources, located in a non-attainment area must undergo non-attainment New Source Review, if they have the potential to emit above an NSR significant threshold. For major new sources or major modifications in an attainment or unclassifiable area, the non-attainment provisions apply if the source or modification is located within the area of influence of a non-attainment area. The area of influence is defined as an area, which is outside the boundary of a non-attainment area, but within the locus of all points that are 50 kilometers outside the non-attainment area.

Compressor Station No. 29 is located in an area that is designated as either attainment or not classifiable for all criteria pollutants and is not located in an area of influence outside a non-attainment area. Additionally, Compressor Station No. 29 is not a major source; therefore, this compressor station is not subject to federal non-attainment New Source Review.

### **3.1.4 Applicability of New source Performance Standards (NSPS)**

Standards of Performance for New Sources are published in 40 CFR 60. All Standards apply to all new sources within a given category, regardless of geographic location or ambient air quality at the location.

#### 40 CFR 60 Subpart KKKK

The new turbine to be installed at Compressor Station No. 29 is subject to Subpart KKKK (40 CFR 60.4300), Standards of Performance for Stationary Combustion Turbines, because it will have a maximum heat input at peak load of >10.7 gigajoules/hour (10 MMBtu/hr) based on the higher heating value of the natural gas fuel and because construction will commence after 18

**BEST AVAILABLE COPY**

February 2005. This regulation establishes emission limits for NO<sub>x</sub> and SO<sub>2</sub> and requires performance testing and monitoring of fuel sulfur.

The NO<sub>x</sub> emission limit for Subpart KKKK is based on Table 1 of 40 CFR 60 Subpart KKKK. The limit for new turbines firing natural gas and with a heat input at peak load greater than 50 MMBtu/h but not more than 850 MMBtu/h is 25 ppm at 15% O<sub>2</sub>. SO<sub>2</sub> emissions are limited to 0.060 lb SO<sub>2</sub>/MMBtu heat input. For this turbine the limit will be 4.03 lb/hr.

Table 3-3 summarizes the NSPS applicability for the proposed gas engines. FGT will also be required to comply with all recordkeeping and monitoring requirements of this regulation.

The turbine will meet the NSPS for NO<sub>x</sub> of 25 ppmv (i.e., manufacturer's estimation of 25 ppmv), and for SO<sub>2</sub> of 4.03 lb/hr (estimated for this turbine to be 1.84 lb/hr).

40 CFR 60 Subpart JJJJ

The new emergency generator engines are subject to 40 CFR Subpart 60 Subpart JJJJ Standards of Performance for Stationary Spark Ignition Internal Combustion Engines. Owners and operators of stationary spark ignition internal combustion engines with maximum engine power greater than or equal to 100 hp must comply with the standards for NO<sub>x</sub>, CO and VOC established in Table 1 of Subpart JJJJ. The manufacturer of the proposed generator engines has not provided final emissions data. FGT will only install units that will comply with the applicable standards. FGT will also be required to comply with all recordkeeping and monitoring requirements of this regulation.

Table 3-4 summarizes the NSPS applicability for the proposed gas-fired emergency generator engines.

**Table 3-3 Applicability of New Source Performance Standards Subpart KKKK**

| <b>NSPS Regulations</b> | <b>Fuel</b> | <b>Pollutant</b> | <b>Heat Input Applicability</b> | <b>Equipment Design Maximum</b> | <b>NSPS Emission Limits</b> | <b>Equipment Emissions</b> |
|-------------------------|-------------|------------------|---------------------------------|---------------------------------|-----------------------------|----------------------------|
| 60.4320(a)              | Gas         | NO <sub>x</sub>  | >50 MM Btu/hr                   | 67 MM Btu/hr                    | 25 ppm <sub>v</sub>         | 25 ppm <sub>v</sub>        |
| 60.4330(a)(2)           | Gas         | SO <sub>2</sub>  | >50 MM Btu/hr                   | 67 MM Btu/hr                    | 4.03 lb/hr                  | 1.84 lb/hr                 |

**BEST AVAILABLE COPY**

**Table 3-4 Applicability of New Source Performance Standards Subpart JJJJ**

| <b>NESHAP Regulations</b> | <b>Fuel</b> | <b>Pollutant</b> | <b>Equipment Design Maximum</b> | <b>NSPS Emission Limits (g/hp-hr)</b> | <b>Equipment Emissions (G/hp-hr)</b> |
|---------------------------|-------------|------------------|---------------------------------|---------------------------------------|--------------------------------------|
| 60.4230 Table 1           | Gas         | NO <sub>2</sub>  | 100 hp and higher               | 2.0                                   | 2.00                                 |
| 60.4230 Table 1           | Gas         | CO               | 100 hp and higher               | 4.0                                   | 4.00                                 |
| 60.4230 Table 1           | Gas         | VOC              | 100 hp and higher               | 1.0                                   | 0.29                                 |

**3.1.5 Applicability of National Emission Standards for Hazardous Air Pollutants (NESHAPS)**

Section 112 of the Clean Air Act required the USEPA to list categories and subcategories of major sources and area sources of hazardous air pollutants (HAP) and to establish NESHAPS for the listed source categories and subcategories. NESHAPS require all major sources to meet HAP emission standards reflecting the application of the maximum achievable control technology (MACT). Compressor Station 29 is not a major source of HAPS and is, therefore, not subject to any applicable NESHAPS.

**3.1.6 Applicability of Title V**

In 1990, Congress established an operating permit program under Title V of the Clean Air Act Amendments. This operating permit program streamlines the way federal, state, tribal, and local authorities regulate air pollution by consolidating all air pollution control requirements into a single, comprehensive "operating permit" that covers all aspects of a source's year-to-year air pollution activities.

All "major" stationary sources emitting certain air pollutants are required to obtain operating permits. Generally, major sources include those stationary facilities that emit 100 tons or more per year of a regulated air pollutant. Smaller sources are considered "major" in areas that are not meeting the national air quality standards for a particular pollutant. Also, sources of toxic air pollutants (i.e., any source that emits more than 10 tons per year of an individual toxic air pollutant or more than 25 tons per year of any combination of toxic air pollutants) are considered major.

Currently CS 29 will not be a major source under Title V definitions; therefore, CS 29 will not be required to obtain a Title V operating permit.

**Attachment A**

**DEP Forms**

### **3.2 Florida state air Quality Regulations**

Compressor Station No. 29 is currently operating under Permit No.0041004-014-OA and is subject to the provisions of that permit. Rule 62, F.A.C., contains the air quality rules and regulations for the State of Florida. The primary federal regulations that affect Compressor Station No. 29 have been incorporated into or are referenced by these rules. The significant state regulations that are applicable to the new emission units are briefly listed below.

#### **3.2.1 Rule 62-210.300 Permits Required**

FGT is required to obtain a construction permit prior to modification of an emission unit. This requirement is being met by the submittal of this application. After the modification, FGT will be required to modify the state operating permit to incorporate the new sources.

#### **3.2.2 Rule 62-204.240 Ambient Air Quality Standards**

FGT must not violate any of the ambient air quality standards listed under this rule. The proposed new emissions will not violate any air quality standards.

#### **3.2.3 Rule 62-296.320(2) Objectionable Odors**

This rule prohibits the discharge of pollutants that will cause or contribute to an objectionable odor. There will be no odors from the proposed changes.

#### **3.2.4 Rule 62-296.320(4)(b)1 General Particulate Emission Limiting Standards**

FGT is prohibited from allowing the new compressor engine to discharge into the atmosphere the emissions of air pollutants, the density of which is equal to or greater than that designated as Number 1 on the Ringelmann Chart (20 percent opacity). The new engines will not violate this standard.



**BEST AVAILABLE COPY**

**4.0 REFERENCES**

- U.S. Environmental Protection Agency (USEPA). 1980. PSD Workshop Manual. Research Triangle Park, NC.
- U.S. Environmental Protection Agency (USEPA). 1985. Protocol for Equipment Leak Emission Estimates, EPA-453/R-95-017
- U.S. Environmental Protection Agency (USEPA). 2000. Compilation of Air Pollutant Emission Factors, Volume I: Stationary Point and Area Sources (5<sup>th</sup> Ed.) AP-42. Supplement E, Research Triangle Park, NC.

BEST AVAILABLE COPY



Department of Environmental Protection
Division of Air Resource Management
APPLICATION FOR AIR PERMIT - LONG FORM

RECEIVED
NOV 26 2008
BUREAU OF AIR REGULATION

I. APPLICATION INFORMATION

Air Construction Permit - Use this form to apply for an air construction permit:

- For any required purpose at a facility operating under a federally enforceable state air operation permit (FESOP) or Title V air operation permit;
For a proposed project subject to prevention of significant deterioration (PSD) review, nonattainment new source review, or maximum achievable control technology (MACT);
To assume a restriction on the potential emissions of one or more pollutants to escape a requirement such as PSD review, nonattainment new source review, MACT, or Title V; or
To establish, revise, or renew a plantwide applicability limit (PAL).

Air Operation Permit - Use this form to apply for:

- An initial federally enforceable state air operation permit (FESOP); or
An initial, revised, or renewal Title V air operation permit.

To ensure accuracy, please see form instructions.

Identification of Facility

1. Facility Owner/Company Name: Florida Gas Transmission Company, LLC
2. Site Name: Compressor Station No. 29
3. Facility Identification Number: unknown - 0550060
4. Facility Location...
Street Address or Other Locator: 13 miles west of US 441 on SH 70
City: Okeechobee County: Highlands Zip Code: 34974
5. Relocatable Facility? [ ] Yes [X] No
6. Existing Title V Permitted Facility? [ ] Yes [X] No

Application Contact

1. Application Contact Name: Charles Wait
2. Application Contact Mailing Address...
Organization/Firm: Florida Gas Transmission Company, LLC
Street Address: 5444 Westheimer
City: Houston State: TX Zip Code: 77056
3. Application Contact Telephone Numbers...
Telephone: ( 713 ) 989 - 7459 ext. Fax: ( 713 ) 989 - 1135
4. Application Contact E-mail Address: charles.wait@SUG.com

Application Processing Information (DEP Use)

1. Date of Receipt of Application: 1-26-08
2. Project Number(s): 0550060-00-AC1
3. PSD Number (if applicable):
4. Siting Number (if applicable):

## APPLICATION INFORMATION

### Purpose of Application

**This application for air permit is being submitted to obtain: (Check one)**

#### **Air Construction Permit**

- Air construction permit.
- Air construction permit to establish, revise, or renew a plantwide applicability limit (PAL).
- Air construction permit to establish, revise, or renew a plantwide applicability limit (PAL), and separate air construction permit to authorize construction or modification of one or more emissions units covered by the PAL.

#### **Air Operation Permit**

- Initial Title V air operation permit.
- Title V air operation permit revision.
- Title V air operation permit renewal.
- Initial federally enforceable state air operation permit (FESOP) where professional engineer (PE) certification is required.
- Initial federally enforceable state air operation permit (FESOP) where professional engineer (PE) certification is not required.

#### **Air Construction Permit and Revised/Renewal Title V Air Operation Permit (Concurrent Processing)**

- Air construction permit and Title V permit revision, incorporating the proposed project.
- Air construction permit and Title V permit renewal, incorporating the proposed project.

**Note: By checking one of the above two boxes, you, the applicant, are requesting concurrent processing pursuant to Rule 62-213.405, F.A.C. In such case, you must also check the following box:**

- I hereby request that the department waive the processing time requirements of the air construction permit to accommodate the processing time frames of the Title V air operation permit.

### Application Comment

Florida Gas Transmission Company is proposing to construct a new compressor station and install two new 7,800 bhp gas-fire compressor turbines and two new 454 bhp gas-fired SI ICE 4-stroke rich-burn emergency generator engines.

These proposed modifications are part of FGT's Phase VIII Expansion project, aimed at increasing the supply capacity of FGT's network servicing domestic, commercial, and industrial customers in Florida.



**APPLICATION INFORMATION**

**Owner/Authorized Representative Statement**

**Complete if applying for an air construction permit or an initial FESOP.**

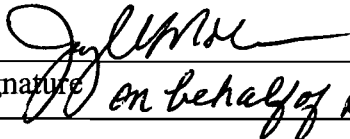
|   |
|---|
| 1. Owner/Authorized Representative Name :<br>David Shellhouse, Vice President, Southeastern Operations  |
| 2. Owner/Authorized Representative Mailing Address<br>Organization/Firm: Florida Gas Transmission Company, LLC<br>Street Address: 2405 Lucien Way, Suite 200<br>City: Maitland State: FL Zip Code: 32751  |
| 3. Owner/Authorized Representative Telephone Numbers...<br>Telephone: ( 407 ) 838 - 7122 ext. Fax: ( 407 ) 838 - 7151   |
| 4. Owner/Authorized Representative E-mail Address: <u>dave.shellhouse@SUG.com</u>   |
| 5. Owner/Authorized Representative Statement:<br><br><i>I, the undersigned, am the owner or authorized representative of the corporation, partnership, or other legal entity submitting this air permit application. To the best of my knowledge, the statements made in this application are true, accurate and complete, and any estimates of emissions reported in this application are based upon reasonable techniques for calculating emissions. I understand that a permit, if granted by the department, cannot be transferred without authorization from the department.</i><br><br><p>Signature <u></u> Date <u>11-25-08</u><br/><i>on behalf of David Shellhouse</i></p> |

## APPLICATION INFORMATION

### Application Responsible Official Certification

**Complete if applying for an initial, revised, or renewal Title V air operation permit or concurrent processing of an air construction permit and revised or renewal Title V air operation permit. If there are multiple responsible officials, the "application responsible official" need not be the "primary responsible official."**

|   |
|---|
| 1. Application Responsible Official Name: NA  |
| 2. Application Responsible Official Qualification (Check one or more of the following options, as applicable):<br><input type="checkbox"/> For a corporation, the president, secretary, treasurer, or vice-president of the corporation in charge of a principal business function, or any other person who performs similar policy or decision-making functions for the corporation, or a duly authorized representative of such person if the representative is responsible for the overall operation of one or more manufacturing, production, or operating facilities applying for or subject to a permit under Chapter 62-213, F.A.C.<br><input type="checkbox"/> For a partnership or sole proprietorship, a general partner or the proprietor, respectively.<br><input type="checkbox"/> For a municipality, county, state, federal, or other public agency, either a principal executive officer or ranking elected official.<br><input type="checkbox"/> The designated representative at an Acid Rain source, CAIR source, or Hg Budget source.   |
| 3. Application Responsible Official Mailing Address...<br>Organization/Firm:<br>Street Address:<br>City: State: Zip Code:   |
| 4. Application Responsible Official Telephone Numbers...<br>Telephone: ( ) - ext. Fax: ( ) -  |
| 5. Application Responsible Official E-mail Address:   |
| 6. Application Responsible Official Certification:<br><i>I, the undersigned, am a responsible official of the Title V source addressed in this air permit application. I hereby certify, based on information and belief formed after reasonable inquiry, that the statements made in this application are true, accurate and complete and that, to the best of my knowledge, any estimates of emissions reported in this application are based upon reasonable techniques for calculating emissions. The air pollutant emissions units and air pollution control equipment described in this application will be operated and maintained so as to comply with all applicable standards for control of air pollutant emissions found in the statutes of the State of Florida and rules of the Department of Environmental Protection and revisions thereof and all other applicable requirements identified in this application to which the Title V source is subject. I understand that a permit, if granted by the department, cannot be transferred without authorization from the department, and I will promptly notify the department upon sale or legal transfer of the facility or any permitted emissions unit. Finally, I certify that the facility and each emissions unit are in compliance with all applicable requirements to which they are subject, except as identified in compliance plan(s) submitted with this application.</i><br><br>_____<br>Signature<br><br>_____<br>Date |

BEST AVAILABLE COPY

APPLICATION INFORMATION

**Professional Engineer Certification**

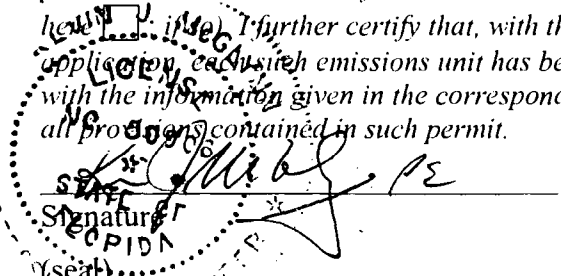
|  |
|--|
| 1. Professional Engineer Name: Kevin J. McGlynn<br>Registration Number: 50908  |
| 2. Professional Engineer Mailing Address.<br>Organization/Firm: Trow Engineering consultants, Inc.<br>Street Address: 1200 Metropolitan Blvd. Ste. 200<br>City: Tallahassee State: FL Zip Code: 32308  |
| 3. Professional Engineer Telephone Numbers.<br>Telephone: ( 850 ) 385 - 5441 ext. 314 Fax: ( 850 ) 385 - 5523  |
| 4. Professional Engineer E-mail Address: <u>Kevin.mcglynn@trow.com</u>   |
| 5. Professional Engineer Statement:<br><i>I, the undersigned, hereby certify, except as particularly noted herein*, that:</i><br><i>(1) To the best of my knowledge, there is reasonable assurance that the air pollutant emissions unit(s) and the air pollution control equipment described in this application for air permit, when properly operated and maintained, will comply with all applicable standards for control of air pollutant emissions found in the Florida Statutes and rules of the Department of Environmental Protection; and</i><br><i>(2) To the best of my knowledge, any emission estimates reported or relied on in this application are true, accurate, and complete and are either based upon reasonable techniques available for calculating emissions or, for emission estimates of hazardous air pollutants not regulated for an emissions unit addressed in this application, based solely upon the materials, information and calculations submitted with this application.</i><br><i>(3) If the purpose of this application is to obtain a Title V air operation permit (check here <input type="checkbox"/> , if so), I further certify that each emissions unit described in this application for air permit, when properly operated and maintained, will comply with the applicable requirements identified in this application to which the unit is subject, except those emissions units for which a compliance plan and schedule is submitted with this application.</i><br><i>(4) If the purpose of this application is to obtain an air construction permit (check here <input checked="" type="checkbox"/> , if so) or concurrently process and obtain an air construction permit and a Title V air operation permit revision or renewal for one or more proposed new or modified emissions units (check here <input type="checkbox"/> , if so), I further certify that the engineering features of each such emissions unit described in this application have been designed or examined by me or individuals under my direct supervision and found to be in conformity with sound engineering principles applicable to the control of emissions of the air pollutants characterized in this application.</i><br><i>(5) If the purpose of this application is to obtain an initial air operation permit or operation permit revision or renewal for one or more newly constructed or modified emissions units (check here <input type="checkbox"/> , if so), I further certify that, with the exception of any changes detailed as part of this application, each such emissions unit has been constructed or modified in substantial accordance with the information given in the corresponding application for air construction permit and with all provisions contained in such permit.</i><br><br>Signature: <u>Kevin J. McGlynn PE</u><br>Date: <u>Nov. 18, 2008</u> |

\* Attach any exception to certification statement.

**II. FACILITY INFORMATION**  
**A. GENERAL FACILITY INFORMATION**

**Facility Location and Type**

|  |                                  |  |                                 |
|--|----------------------------------|--|---------------------------------|
| 1. Facility UTM Coordinates...<br>Zone 17      East (km)      494.3<br>North (km)      3012.4  |                                  | 2. Facility Latitude/Longitude...<br>Latitude (DD/MM/SS)<br>Longitude (DD/MM/SS) |                                 |
| 3. Governmental<br>Facility Code:<br>0   | 4. Facility Status<br>Code:<br>C | 5. Facility Major<br>Group SIC Code:<br>49                                       | 6. Facility SIC(s):<br><br>4922 |
| 7. Facility Comment :<br><br>Compressor Station No. 29 will be a new natural gas pipeline compressor station with two compressor turbines. |                                  |  |                                 |

**Facility Contact**

|  |
|--|
| 1. Facility Contact Name: : Unknown at this time   |
| 2. Facility Contact Mailing Address:<br>Organization/Firm:      Unknown at this time<br>Street Address:<br>City:      Okeechobee      State:      FL      Zip Code:      34974 |
| 3. Facility Contact Telephone Numbers:<br>Telephone: ( *** ) *** - ****      ext.      Fax:      ( *** ) *** - ****  |
| 4. Facility Contact E-mail Address: *****  |

**Facility Primary Responsible Official**

**Complete if an "application responsible official" is identified in Section I that is not the facility "primary responsible official."**

|  |
|--|
| 1. Facility Primary Responsible Official Name:<br>NA   |
| 2. Facility Primary Responsible Official Mailing Address...<br>Organization/Firm:<br>Street Address:<br>City:      State:      Zip Code: |
| 3. Facility Primary Responsible Official Telephone Numbers...<br>Telephone: (   ) -      ext.      Fax:      (   ) -                     |
| 4. Facility Primary Responsible Official E-mail Address:   |



## FACILITY INFORMATION

### Facility Regulatory Classifications

Check all that would apply *following* completion of all projects and implementation of all other changes proposed in this application for air permit. Refer to instructions to distinguish between a "major source" and a "synthetic minor source."

|     |   |                                  |
|-----|---|----------------------------------|
| 1.  | <input type="checkbox"/> Small Business Stationary Source   | <input type="checkbox"/> Unknown |
| 2.  | <input type="checkbox"/> Synthetic Non-Title V Source   |                                  |
| 3.  | <input type="checkbox"/> Title V Source   |                                  |
| 4.  | <input type="checkbox"/> Major Source of Air Pollutants, Other than Hazardous Air Pollutants (HAPs)   |                                  |
| 5.  | <input type="checkbox"/> Synthetic Minor Source of Air Pollutants, Other than HAPs  |                                  |
| 6.  | <input type="checkbox"/> Major Source of Hazardous Air Pollutants (HAPs)  |                                  |
| 7.  | <input type="checkbox"/> Synthetic Minor Source of HAPs   |                                  |
| 8.  | <input checked="" type="checkbox"/> One or More Emissions Units Subject to NSPS (40 CFR Part 60)  |                                  |
| 9.  | <input type="checkbox"/> One or More Emissions Units Subject to Emission Guidelines (40 CFR Part 60)  |                                  |
| 10. | <input type="checkbox"/> One or More Emissions Units Subject to NESHAP (40 CFR Part 61 or Part 63)  |                                  |
| 11. | <input type="checkbox"/> Title V Source Solely by EPA Designation (40 CFR 70.3(a)(5))   |                                  |
| 12. | Facility Regulatory Classifications Comment:<br><br>Facility will be a major source of Air Pollutants after these modifications.<br><br>New gas-fired compressor turbines (No. 2901/2902) are subject to (NSPS) 40 CFR Part 60, Subpart KKKK<br><br>New gas-fired reciprocating internal combustion emergency generator engines are subject to (NSPS) 40 CFR 60 Subpart JJJJ. |                                  |





## FACILITY INFORMATION

### C. FACILITY ADDITIONAL INFORMATION

#### Additional Requirements for All Applications, Except as Otherwise Stated

|   |
|---|
| 1. Facility Plot Plan: (Required for all permit applications, except Title V air operation permit revision applications if this information was submitted to the department within the previous five years and would not be altered as a result of the revision being sought)<br><input checked="" type="checkbox"/> Attached, Document ID: <u>Attach. D</u> <input type="checkbox"/> Previously Submitted, Date: _____   |
| 2. Process Flow Diagram(s): (Required for all permit applications, except Title V air operation permit revision applications if this information was submitted to the department within the previous five years and would not be altered as a result of the revision being sought)<br><input checked="" type="checkbox"/> Attached, Document ID: <u>Attach. B</u> <input type="checkbox"/> Previously Submitted, Date: _____  |
| 3. Precautions to Prevent Emissions of Unconfined Particulate Matter: (Required for all permit applications, except Title V air operation permit revision applications if this information was submitted to the department within the previous five years and would not be altered as a result of the revision being sought)<br><input checked="" type="checkbox"/> Attached, Document ID <u>Attach. C</u> <input type="checkbox"/> Previously Submitted, Date: _____ |

#### Additional Requirements for Air Construction Permit Applications

|   |
|---|
| 1. Area Map Showing Facility Location:<br><input checked="" type="checkbox"/> Attached, Document ID: <u>Narr.Fig. 1-1</u> <input type="checkbox"/> Not Applicable (existing permitted facility) |
| 2. Description of Proposed Construction, Modification, or Plantwide Applicability Limit (PAL):<br><input checked="" type="checkbox"/> Attached, Document ID: <u>Narr.Sect 2.0</u>               |
| 3. Rule Applicability Analysis:<br><input checked="" type="checkbox"/> Attached, Document ID: <u>Narr.Sect 3.0</u>  |
| 4. List of Exempt Emissions Units:<br><input checked="" type="checkbox"/> Attached, Document ID: <u>Attach. H</u> <input type="checkbox"/> Not Applicable (no exempt units at facility)         |
| 5. Fugitive Emissions Identification:<br><input checked="" type="checkbox"/> Attached, Document ID: <u>Narr.Sect 2.2.5</u> <input type="checkbox"/> Not Applicable                              |
| 6. Air Quality Analysis (Rule 62-212.400(7), F.A.C.):<br><input type="checkbox"/> Attached, Document ID: _____ <input checked="" type="checkbox"/> Not Applicable                               |
| 7. Source Impact Analysis (Rule 62-212.400(5), F.A.C.):<br><input type="checkbox"/> Attached, Document ID: _____ <input checked="" type="checkbox"/> Not Applicable                             |
| 8. Air Quality Impact since 1977 (Rule 62-212.400(4)(e), F.A.C.):<br><input type="checkbox"/> Attached, Document ID: _____ <input checked="" type="checkbox"/> Not Applicable                   |
| 9. Additional Impact Analyses (Rules 62-212.400(8) and 62-212.500(4)(e), F.A.C.):<br><input type="checkbox"/> Attached, Document ID: _____ <input checked="" type="checkbox"/> Not Applicable   |
| 10. Alternative Analysis Requirement (Rule 62-212.500(4)(g), F.A.C.):<br><input type="checkbox"/> Attached, Document ID: _____ <input checked="" type="checkbox"/> Not Applicable               |

## FACILITY INFORMATION

### C. FACILITY ADDITIONAL INFORMATION (CONTINUED)

#### Additional Requirements for FESOP Applications

- |   |
|---|
| 1. List of Exempt Emissions Units:<br><input type="checkbox"/> Attached, Document ID: <u>NA</u> <input type="checkbox"/> Not Applicable (no exempt units at facility) |
|---|

#### Additional Requirements for Title V Air Operation Permit Applications

|  |
|--|
| 1. List of Insignificant Activities: (Required for initial/renewal applications only)<br><input type="checkbox"/> Attached, Document ID: <u>NA</u> <input type="checkbox"/> Not Applicable (revision application)  |
| 2. Identification of Applicable Requirements: (Required for initial/renewal applications, and for revision applications if this information would be changed as a result of the revision being sought)<br><input type="checkbox"/> Attached, Document ID: <u>NA</u><br><input type="checkbox"/> Not Applicable (revision application with no change in applicable requirements)  |
| 3. Compliance Report and Plan: (Required for all initial/revision/renewal applications)<br><input type="checkbox"/> Attached, Document ID: <u>NA</u><br><br>Note: A compliance plan must be submitted for each emissions unit that is not in compliance with all applicable requirements at the time of application and/or at any time during application processing. The department must be notified of any changes in compliance status during application processing. |
| 4. List of Equipment/Activities Regulated under Title VI: (If applicable, required for initial/renewal applications only)<br><input type="checkbox"/> Attached, Document ID: <u>NA</u><br><input type="checkbox"/> Equipment/Activities Onsite but Not Required to be Individually Listed<br><input type="checkbox"/> Not Applicable   |
| 5. Verification of Risk Management Plan Submission to EPA: (If applicable, required for initial/renewal applications only)<br><input type="checkbox"/> Attached, Document ID: <u>NA</u> <input type="checkbox"/> Not Applicable  |
| 6. Requested Changes to Current Title V Air Operation Permit:<br><input type="checkbox"/> Attached, Document ID: <u>NA</u> <input type="checkbox"/> Not Applicable   |

## FACILITY INFORMATION

### C. FACILITY ADDITIONAL INFORMATION (CONTINUED)

#### Additional Requirements for Facilities Subject to Acid Rain, CAIR, or Hg Budget Program

1. Acid Rain Program Forms: NA

Acid Rain Part Application (DEP Form No. 62-210.900(1)(a)):

Attached, Document ID: \_\_\_\_\_  Previously Submitted, Date: \_\_\_\_\_

Not Applicable (not an Acid Rain source)

Phase II NO<sub>x</sub> Averaging Plan (DEP Form No. 62-210.900(1)(a)1.):

Attached, Document ID: \_\_\_\_\_  Previously Submitted, Date: \_\_\_\_\_

Not Applicable

New Unit Exemption (DEP Form No. 62-210.900(1)(a)2.):

Attached, Document ID: \_\_\_\_\_  Previously Submitted, Date: \_\_\_\_\_

Not Applicable

2. CAIR Part (DEP Form No. 62-210.900(1)(b)): NA

Attached, Document ID: \_\_\_\_\_  Previously Submitted, Date: \_\_\_\_\_

Not Applicable (not a CAIR source)

3. Hg Budget Part (DEP Form No. 62-210.900(1)(c)): NA

Attached, Document ID: \_\_\_\_\_  Previously Submitted, Date: \_\_\_\_\_

Not Applicable (not a Hg Budget unit)

#### Additional Requirements Comment

Attachment B provides a Process Flow Diagram

Attachment C presents Precautions to Prevent Emissions of Unconfined Particulate Matter

Attachment D contains a plot plan.

Attachment E has vendor supplied information.

Attachment F has supporting calculations.

Attachment G contains a fuel analysis

Attachment H contains a list of Exempt Emission Units

**EMISSIONS UNIT INFORMATION**

Section | 1 | of | 4 |

**A. GENERAL EMISSIONS UNIT INFORMATION**

**Title V Air Operation Permit Emissions Unit Classification**

1. Regulated or Unregulated Emissions Unit? (Check one, if applying for an initial, revised or renewal Title V air operation permit. Skip this item if applying for an air construction permit or FESOP only.) NA

The emissions unit addressed in this Emissions Unit Information Section is a regulated emissions unit.

The emissions unit addressed in this Emissions Unit Information Section is an unregulated emissions unit.

**Emissions Unit Description and Status**

1. Type of Emissions Unit Addressed in this Section: (Check one)

This Emissions Unit Information Section addresses, as a single emissions unit, a single process or production unit, or activity, which produces one or more air pollutants and which has at least one definable emission point (stack or vent).

This Emissions Unit Information Section addresses, as a single emissions unit, a group of process or production units and activities which has at least one definable emission point (stack or vent) but may also produce fugitive emissions.

This Emissions Unit Information Section addresses, as a single emissions unit, one or more process or production units and activities which produce fugitive emissions only.

2. Description of Emissions Unit Addressed in this Section:

7,800 bhp (ISO) natural gas fired turbine compressor unit, FGT Engine No. 2901

3. Emissions Unit Identification Number: 001

|   |  |                                    |   |
|---|--|------------------------------------|---|
| 4. Emissions Unit Status Code:<br><br>C | 5. Commence Construction Date:<br><br>NA | 6. Initial Startup Date:<br><br>NA | 7. Emissions Unit Major Group SIC Code:<br><br>49 |
|---|--|------------------------------------|---|

8. Federal Program Applicability: (Check all that apply)

Acid Rain Unit

CAIR Unit

Hg Budget Unit

9. Package Unit:  
Manufacturer: Solar  
Model Number: Taurus 60 - 7800S

10. Generator Nameplate Rating: MW

11. Emissions Unit Comment:

Fuel will be exclusively natural gas from the FGT's gas pipeline. The proposed engine will incorporate dry, low NO<sub>x</sub> combustion technology. 7,277 bhp with inlet and exhaust losses of 4.0 inches H<sub>2</sub>O.

**EMISSIONS UNIT INFORMATION**

Section [ 1 ] of [ 4 ]

**Emissions Unit Control Equipment/Method:** Control 1 of 1

1. Control Equipment/Method Description:

The proposed engine will incorporate dry, low NO<sub>x</sub> combustion technology.

2. Control Device or Method Code: 99

**Emissions Unit Control Equipment/Method:** Control \_\_\_ of \_\_\_

1. Control Equipment/Method Description:

2. Control Device or Method Code:

**Emissions Unit Control Equipment/Method:** Control \_\_\_ of \_\_\_

1. Control Equipment/Method Description:

2. Control Device or Method Code:

**Emissions Unit Control Equipment/Method:** Control \_\_\_ of \_\_\_

1. Control Equipment/Method Description:

2. Control Device or Method Code:



**EMISSIONS UNIT INFORMATION**

Section [ 1 ] of [ 4 ]

**B. EMISSIONS UNIT CAPACITY INFORMATION**

**(Optional for unregulated emissions units.)**

**Emissions Unit Operating Capacity and Schedule**

|   |
|---|
| 1. Maximum Process or Throughput Rate: NA   |
| 2. Maximum Production Rate: NA  |
| 3. Maximum Heat Input Rate: 67.09 million Btu/hr HHV  |
| 4. Maximum Incineration Rate: pounds/hr NA<br>tons/day  |
| 5. Requested Maximum Operating Schedule:<br>24 hours/day 7 days/week<br>52 weeks/year 8760 hours/year   |
| 6. Operating Capacity/Schedule Comment:<br><br>Heat input is 67.09 MM Btu/hr Higher heating value (HHV). This is based on a vendor provided bhp of 7,277 bhp, a specific heat rate of 8,326 Btu/hp-hr, a lower heating value (LHV) of 939.2 Btu/scf and a higher heating value (HHV) of 1040 Btu/scf. |

**EMISSIONS UNIT INFORMATION**

Section [ 1 ] of [ 4 ]

**C. EMISSION POINT (STACK/VENT) INFORMATION****(Optional for unregulated emissions units.)****Emission Point Description and Type**

|   |  |   |   |                               |  |
|---|--|---|---|-------------------------------|--|
| 1. Identification of Point on Plot Plan or Flow Diagram: 2901                                 |  | 2. Emission Point Type Code:<br>I               |   |                               |  |
| 3. Descriptions of Emission Points Comprising this Emissions Unit for VE Tracking:<br><br>NA  |  |   |   |                               |  |
| 4. ID Numbers or Descriptions of Emission Units with this Emission Point in Common:<br><br>NA |  |   |   |                               |  |
| 5. Discharge Type Code:<br>V  |  | 6. Stack Height:<br>55 Feet                     |   | 7. Exit Diameter:<br>6.0 feet |  |
| 8. Exit Temperature:<br>956 °F  |  | 9. Actual Volumetric Flow Rate:<br>101,546 acfm |   | 10. Water Vapor:<br>NA %      |  |
| 11. Maximum Dry Standard Flow Rate:<br>NA dscfm   |  |   | 12. Nonstack Emission Point Height:<br>NA feet  |                               |  |
| 13. Emission Point UTM Coordinates...<br>Zone: 17 East (km): 494.3<br>North (km): 3012.4      |  |   | 14. Emission Point Latitude/Longitude...<br>Latitude (DD/MM/SS)<br>Longitude (DD/MM/SS) |                               |  |
| 15. Emission Point Comment:<br><br>None   |  |   |   |                               |  |

**EMISSIONS UNIT INFORMATION**

Section [ 1 ] of [ 4 ]

**D. SEGMENT (PROCESS/FUEL) INFORMATION**

**Segment Description and Rate:** Segment  1  of  1

|  |                                   |  |
|--|-----------------------------------|--|
| 1. Segment Description (Process/Fuel Type):<br><br>Natural gas fired turbine engine driving a natural gas compressor, operating full time. |                                   |  |
| 2. Source Classification Code (SCC):<br>2-02-002-01  |                                   | 3. SCC Units:<br>million cubic feet burned |
| 4. Maximum Hourly Rate:<br>0.0645  | 5. Maximum Annual Rate:<br>565.10 | 6. Estimated Annual Activity Factor:<br>NA |
| 7. Maximum % Sulfur:<br>NA   | 8. Maximum % Ash:<br>NA           | 9. Million Btu per SCC Unit:<br>1040       |
| 10. Segment Comment:<br><br>None   |                                   |  |

**Segment Description and Rate:** Segment   of

|   |                         |                                      |
|---|-------------------------|--------------------------------------|
| 1. Segment Description (Process/Fuel Type): |                         |                                      |
| 2. Source Classification Code (SCC):        |                         | 3. SCC Units:                        |
| 4. Maximum Hourly Rate:                     | 5. Maximum Annual Rate: | 6. Estimated Annual Activity Factor: |
| 7. Maximum % Sulfur:                        | 8. Maximum % Ash:       | 9. Million Btu per SCC Unit:         |
| 10. Segment Comment:                        |                         |                                      |



**F1. EMISSIONS UNIT POLLUTANT DETAIL INFORMATION –  
POTENTIAL, FUGITIVE, AND ACTUAL EMISSIONS  
(Optional for unregulated emissions units.)**

Complete a Subsection F1 for each pollutant identified in Subsection E if applying for an air construction permit or concurrent processing of an air construction permit and a revised or renewal Title V operation permit. Complete for each emissions-limited pollutant identified in Subsection E if applying for an air operation permit.

**Potential, Estimated Fugitive, and Baseline & Projected Actual Emissions**

|  |  |   |  |
|--|--|---|--|
| 1. Pollutant Emitted:<br>NOX   |  | 2. Total Percent Efficiency of Control:   |  |
| 3. Potential Emissions:<br>6.04 lb/hour                      26.46 tons/year   |  | 4. Synthetically Limited?<br><input type="checkbox"/> Yes <input checked="" type="checkbox"/> No        |  |
| 5. Range of Estimated Fugitive Emissions (as applicable): NA<br>to tons/year   |  |   |  |
| 6. Emission Factor: 6.04 lb/hr<br><br>Reference: Vendor data   |  | 7. Emissions<br>Method Code:<br>5   |  |
| 8.a. Baseline Actual Emissions (if required):<br>NA tons/year  |  | 8.b. Baseline 24-month Period:<br>From:                      To:  |  |
| 9.a. Projected Actual Emissions (if required):<br>NA tons/year   |  | 9.b. Projected Monitoring Period:<br><input type="checkbox"/> 5 years <input type="checkbox"/> 10 years |  |
| 10. Calculation of Emissions:<br><br>$(6.04 \text{ lb/hr})(1 \text{ ton}/2000 \text{ lb})(8760 \text{ hr}/1 \text{ yr}) = 26.46 \text{ tons/year}$ |  |   |  |
| 11. Potential, Fugitive, and Actual Emissions Comment:<br><br>Vendor's data based on ISO conditions with inlet and exhaust losses of 4" of H2O.    |  |   |  |

**F2. EMISSIONS UNIT POLLUTANT DETAIL INFORMATION -  
ALLOWABLE EMISSIONS**

**Complete Subsection F2 if the pollutant identified in Subsection F1 is or would be subject to a numerical emissions limitation.**

**Allowable Emissions** Allowable Emissions 1 of 1

|   |   |
|---|---|
| 1. Basis for Allowable Emissions Code:<br>RULE  | 2. Future Effective Date of Allowable Emissions: NA                     |
| 3. Allowable Emissions and Units:<br>25 ppmvd @ 15% O2  | 4. Equivalent Allowable Emissions:<br>6.04 lb/hour      26.46 tons/year |
| 5. Method of Compliance:<br>Initial performance test  |   |
| 6. Allowable Emissions Comment (Description of Operating Method):<br><br>40 CFR 60.4320(a) limits NOX emissions to 25 ppmv. |   |

**Allowable Emissions** Allowable Emissions    of   

|   |  |
|---|--|
| 1. Basis for Allowable Emissions Code:                            | 2. Future Effective Date of Allowable Emissions:             |
| 3. Allowable Emissions and Units:                                 | 4. Equivalent Allowable Emissions:<br>lb/hour      tons/year |
| 5. Method of Compliance:  |  |
| 6. Allowable Emissions Comment (Description of Operating Method): |  |

**Allowable Emissions** Allowable Emissions    of   

|   |  |
|---|--|
| 1. Basis for Allowable Emissions Code:                            | 2. Future Effective Date of Allowable Emissions:             |
| 3. Allowable Emissions and Units:                                 | 4. Equivalent Allowable Emissions:<br>lb/hour      tons/year |
| 5. Method of Compliance:  |  |
| 6. Allowable Emissions Comment (Description of Operating Method): |  |

**F1. EMISSIONS UNIT POLLUTANT DETAIL INFORMATION –  
POTENTIAL, FUGITIVE, AND ACTUAL EMISSIONS**  
(Optional for unregulated emissions units.)

Complete a Subsection F1 for each pollutant identified in Subsection E if applying for an air construction permit or concurrent processing of an air construction permit and a revised or renewal Title V operation permit. Complete for each emissions-limited pollutant identified in Subsection E if applying for an air operation permit.

**Potential, Estimated Fugitive, and Baseline & Projected Actual Emissions**

|   |  |   |  |
|---|--|---|--|
| 1. Pollutant Emitted:<br>CO   |  | 2. Total Percent Efficiency of Control:   |  |
| 3. Potential Emissions:<br>7.35 lb/hour                      32.19 tons/year  |  | 4. Synthetically Limited?<br><input type="checkbox"/> Yes <input checked="" type="checkbox"/> No        |  |
| 5. Range of Estimated Fugitive Emissions (as applicable): NA<br>to tons/year  |  |   |  |
| 6. Emission Factor: 7.35 lb/hr<br><br>Reference: Vendor data  |  | 7. Emissions<br>Method Code:<br>5   |  |
| 8.a. Baseline Actual Emissions (if required):<br>NA tons/year   |  | 8.b. Baseline 24-month Period:<br>From:                      To:  |  |
| 9.a. Projected Actual Emissions (if required):<br>NA tons/year  |  | 9.b. Projected Monitoring Period:<br><input type="checkbox"/> 5 years <input type="checkbox"/> 10 years |  |
| 10. Calculation of Emissions:<br><br>(7.35 lb/hr)(1 ton/2000 lb)(8760hr/1 yr) = 32.19 tons/year   |  |   |  |
| 11. Potential, Fugitive, and Actual Emissions Comment:<br><br>Vendor's data based on ISO conditions with inlet and exhaust losses of 4" of H2O. |  |   |  |

**F2. EMISSIONS UNIT POLLUTANT DETAIL INFORMATION -  
 ALLOWABLE EMISSIONS**

**Complete Subsection F2 if the pollutant identified in Subsection F1 is or would be subject to a numerical emissions limitation.**

**Allowable Emissions** Allowable Emissions NA of

|   |  |
|---|--|
| 1. Basis for Allowable Emissions Code:                            | 2. Future Effective Date of Allowable Emissions: NA                          |
| 3. Allowable Emissions and Units:                                 | 4. Equivalent Allowable Emissions:<br>lb/hour                      tons/year |
| 5. Method of Compliance:  |  |
| 6. Allowable Emissions Comment (Description of Operating Method): |  |

**Allowable Emissions** Allowable Emissions \_\_ of \_\_

|   |  |
|---|--|
| 1. Basis for Allowable Emissions Code:                            | 2. Future Effective Date of Allowable Emissions:                             |
| 3. Allowable Emissions and Units:                                 | 4. Equivalent Allowable Emissions:<br>lb/hour                      tons/year |
| 5. Method of Compliance:  |  |
| 6. Allowable Emissions Comment (Description of Operating Method): |  |

**Allowable Emissions** Allowable Emissions \_\_ of \_\_

|   |  |
|---|--|
| 1. Basis for Allowable Emissions Code:                            | 2. Future Effective Date of Allowable Emissions:                             |
| 3. Allowable Emissions and Units:                                 | 4. Equivalent Allowable Emissions:<br>lb/hour                      tons/year |
| 5. Method of Compliance:  |  |
| 6. Allowable Emissions Comment (Description of Operating Method): |  |



**F1. EMISSIONS UNIT POLLUTANT DETAIL INFORMATION –  
 POTENTIAL, FUGITIVE, AND ACTUAL EMISSIONS**  
 (Optional for unregulated emissions units.)

Complete a Subsection F1 for each pollutant identified in Subsection E if applying for an air construction permit or concurrent processing of an air construction permit and a revised or renewal Title V operation permit. Complete for each emissions-limited pollutant identified in Subsection E if applying for an air operation permit.

**Potential, Estimated Fugitive, and Baseline & Projected Actual Emissions**

|   |  |   |  |
|---|--|---|--|
| 1. Pollutant Emitted:<br>VOC  |  | 2. Total Percent Efficiency of Control:   |  |
| 3. Potential Emissions:<br>0.21 lb/hour                      0.92 tons/year   |  | 4. Synthetically Limited?<br><input type="checkbox"/> Yes <input checked="" type="checkbox"/> No        |  |
| 5. Range of Estimated Fugitive Emissions (as applicable): NA<br>to tons/year  |  |   |  |
| 6. Emission Factor: 0.21 lb/hr<br><br>Reference: Vendor data  |  | 7. Emissions Method Code:<br>5  |  |
| 8.a. Baseline Actual Emissions (if required):<br>NA tons/year   |  | 8.b. Baseline 24-month Period:<br>From:                      To:  |  |
| 9.a. Projected Actual Emissions (if required):<br>NA tons/year  |  | 9.b. Projected Monitoring Period:<br><input type="checkbox"/> 5 years <input type="checkbox"/> 10 years |  |
| 10. Calculation of Emissions:<br><br>UHC = 2.11 lb/hr, assume VOC = 10% UHC<br>(0.21 lb/hr)(1 ton/2000 lb)(8760hr/1 yr) = 0.92 tons/year        |  |   |  |
| 11. Potential, Fugitive, and Actual Emissions Comment:<br><br>Vendor's data based on ISO conditions with inlet and exhaust losses of 4" of H2O. |  |   |  |

**F2. EMISSIONS UNIT POLLUTANT DETAIL INFORMATION -  
 ALLOWABLE EMISSIONS**

**Complete Subsection F2 if the pollutant identified in Subsection F1 is or would be subject to a numerical emissions limitation.**

**Allowable Emissions** Allowable Emissions NA of

|   |  |
|---|--|
| 1. Basis for Allowable Emissions Code:                            | 2. Future Effective Date of Allowable Emissions:                             |
| 3. Allowable Emissions and Units:                                 | 4. Equivalent Allowable Emissions:<br>lb/hour                      tons/year |
| 5. Method of Compliance:  |  |
| 6. Allowable Emissions Comment (Description of Operating Method): |  |

**Allowable Emissions** Allowable Emissions    of   

|   |  |
|---|--|
| 1. Basis for Allowable Emissions Code:                            | 2. Future Effective Date of Allowable Emissions:                             |
| 3. Allowable Emissions and Units:                                 | 4. Equivalent Allowable Emissions:<br>lb/hour                      tons/year |
| 5. Method of Compliance:  |  |
| 6. Allowable Emissions Comment (Description of Operating Method): |  |

**Allowable Emissions** Allowable Emissions    of   

|   |  |
|---|--|
| 1. Basis for Allowable Emissions Code:                            | 2. Future Effective Date of Allowable Emissions:                             |
| 3. Allowable Emissions and Units:                                 | 4. Equivalent Allowable Emissions:<br>lb/hour                      tons/year |
| 5. Method of Compliance:  |  |
| 6. Allowable Emissions Comment (Description of Operating Method): |  |

**F1. EMISSIONS UNIT POLLUTANT DETAIL INFORMATION –  
POTENTIAL, FUGITIVE, AND ACTUAL EMISSIONS  
(Optional for unregulated emissions units.)**

Complete a Subsection F1 for each pollutant identified in Subsection E if applying for an air construction permit or concurrent processing of an air construction permit and a revised or renewal Title V operation permit. Complete for each emissions-limited pollutant identified in Subsection E if applying for an air operation permit.

**Potential, Estimated Fugitive, and Baseline & Projected Actual Emissions**

|  |  |   |  |
|--|--|---|--|
| 1. Pollutant Emitted:<br>SO2   |  | 2. Total Percent Efficiency of Control:   |  |
| 3. Potential Emissions:<br>1.84 lb/hour                      8.07 tons/year  |  | 4. Synthetically Limited?<br><input type="checkbox"/> Yes <input checked="" type="checkbox"/> No        |  |
| 5. Range of Estimated Fugitive Emissions (as applicable): NA<br>to tons/year   |  |   |  |
| 6. Emission Factor: 10 grain/100 scf<br><br>Reference: FERC limit  |  | 7. Emissions<br>Method Code:<br>2   |  |
| 8.a. Baseline Actual Emissions (if required):<br>NA tons/year  |  | 8.b. Baseline 24-month Period:<br>From:                      To:  |  |
| 9.a. Projected Actual Emissions (if required):<br>NA tons/year   |  | 9.b. Projected Monitoring Period:<br><input type="checkbox"/> 5 years <input type="checkbox"/> 10 years |  |
| 10. Calculation of Emissions:<br><br>$(10 \text{ gr S}/100 \text{ scf})(64,500 \text{ scf/hr})(1 \text{ lb}/7000 \text{ gr}) = 0.921 \text{ lb S/hr}$<br>$(0.921 \text{ lb S/hr})(2 \text{ lb SO}_2/\text{lb S}) = 1.843 \text{ lb SO}_2/\text{hr}$<br>$(1.843 \text{ lb SO}_2/\text{hr})(8760 \text{ hr/yr})(1 \text{ ton}/2000 \text{ lb}) = 8.073 \text{ ton/yr}$ |  |   |  |
| 11. Potential, Fugitive, and Actual Emissions Comment:<br><br>Vendor's data based on ISO conditions with inlet and exhaust losses of 4" of H2O.  |  |   |  |

**F2. EMISSIONS UNIT POLLUTANT DETAIL INFORMATION -  
 ALLOWABLE EMISSIONS**

**Complete Subsection F2 if the pollutant identified in Subsection F1 is or would be subject to a numerical emissions limitation.**

**Allowable Emissions** Allowable Emissions 1 of 1

|   |  |
|---|--|
| 1. Basis for Allowable Emissions Code:<br>RULE  | 2. Future Effective Date of Allowable Emissions: NA                    |
| 3. Allowable Emissions and Units:   | 4. Equivalent Allowable Emissions:<br>1.84 lb/hour      8.07 tons/year |
| 5. Method of Compliance:<br>Initial performance test  |  |
| 6. Allowable Emissions Comment (Description of Operating Method):<br><br>40 CFR 60.4330(a)(2) limits SO <sub>2</sub> emissions to 4.03 lb/hr. |  |

**Allowable Emissions** Allowable Emissions \_\_ of \_\_

|   |  |
|---|--|
| 1. Basis for Allowable Emissions Code:                            | 2. Future Effective Date of Allowable Emissions:             |
| 3. Allowable Emissions and Units:                                 | 4. Equivalent Allowable Emissions:<br>lb/hour      tons/year |
| 5. Method of Compliance:  |  |
| 6. Allowable Emissions Comment (Description of Operating Method): |  |

**Allowable Emissions** Allowable Emissions \_\_ of \_\_

|   |  |
|---|--|
| 1. Basis for Allowable Emissions Code:                            | 2. Future Effective Date of Allowable Emissions:             |
| 3. Allowable Emissions and Units:                                 | 4. Equivalent Allowable Emissions:<br>lb/hour      tons/year |
| 5. Method of Compliance:  |  |
| 6. Allowable Emissions Comment (Description of Operating Method): |  |

**F1. EMISSIONS UNIT POLLUTANT DETAIL INFORMATION –  
POTENTIAL, FUGITIVE, AND ACTUAL EMISSIONS**

(Optional for unregulated emissions units.)

Complete a Subsection F1 for each pollutant identified in Subsection E if applying for an air construction permit or concurrent processing of an air construction permit and a revised or renewal Title V operation permit. Complete for each emissions-limited pollutant identified in Subsection E if applying for an air operation permit.

**Potential, Estimated Fugitive, and Baseline & Projected Actual Emissions**

|  |  |   |  |
|--|--|---|--|
| 1. Pollutant Emitted:<br>PM  |  | 2. Total Percent Efficiency of Control:   |  |
| 3. Potential Emissions:<br>0.44 lb/hour                      1.94 tons/year  |  | 4. Synthetically Limited?<br><input type="checkbox"/> Yes <input checked="" type="checkbox"/> No        |  |
| 5. Range of Estimated Fugitive Emissions (as applicable): NA<br>to tons/year   |  |   |  |
| 6. Emission Factor: 0.0066 lb/MM Btu<br><br>Reference: Table 3.1-2a, AP-42 4/00  |  | 7. Emissions<br>Method Code:<br>3   |  |
| 8.a. Baseline Actual Emissions (if required):<br>NA tons/year  |  | 8.b. Baseline 24-month Period:<br>From:                      To:  |  |
| 9.a. Projected Actual Emissions (if required):<br>NA tons/year   |  | 9.b. Projected Monitoring Period:<br><input type="checkbox"/> 5 years <input type="checkbox"/> 10 years |  |
| 10. Calculation of Emissions:<br><br>$(0.0066 \text{ lb/MM Btu})(64.50 \text{ MM Btu/hr}) = 0.443 \text{ lb/hr}$<br>$(0.443 \text{ lb/hr})(8760 \text{ hr/yr})(1 \text{ ton}/2000 \text{ lb}) = 1.939 \text{ ton/y}$ |  |   |  |
| 11. Potential, Fugitive, and Actual Emissions Comment:<br><br>Based on vendor's heat input data at ISO conditions with inlet and exhaust losses of 4" of H2O and fuel higher heat value of 1040 Btu/scf              |  |   |  |

**F2. EMISSIONS UNIT POLLUTANT DETAIL INFORMATION -  
 ALLOWABLE EMISSIONS**

**Complete Subsection F2 if the pollutant identified in Subsection F1 is or would be subject to a numerical emissions limitation.**

**Allowable Emissions** Allowable Emissions NA of

|   |  |
|---|--|
| 1. Basis for Allowable Emissions Code:                            | 2. Future Effective Date of Allowable Emissions: NA                          |
| 3. Allowable Emissions and Units:                                 | 4. Equivalent Allowable Emissions:<br>lb/hour                      tons/year |
| 5. Method of Compliance:  |  |
| 6. Allowable Emissions Comment (Description of Operating Method): |  |

**Allowable Emissions** Allowable Emissions \_\_ of \_\_

|   |  |
|---|--|
| 1. Basis for Allowable Emissions Code:                            | 2. Future Effective Date of Allowable Emissions:                             |
| 3. Allowable Emissions and Units:                                 | 4. Equivalent Allowable Emissions:<br>lb/hour                      tons/year |
| 5. Method of Compliance:  |  |
| 6. Allowable Emissions Comment (Description of Operating Method): |  |

**Allowable Emissions** Allowable Emissions \_\_ of \_\_

|   |  |
|---|--|
| 1. Basis for Allowable Emissions Code:                            | 2. Future Effective Date of Allowable Emissions:                             |
| 3. Allowable Emissions and Units:                                 | 4. Equivalent Allowable Emissions:<br>lb/hour                      tons/year |
| 5. Method of Compliance:  |  |
| 6. Allowable Emissions Comment (Description of Operating Method): |  |

**F1. EMISSIONS UNIT POLLUTANT DETAIL INFORMATION –  
POTENTIAL, FUGITIVE, AND ACTUAL EMISSIONS**  
(Optional for unregulated emissions units.)

Complete a Subsection F1 for each pollutant identified in Subsection E if applying for an air construction permit or concurrent processing of an air construction permit and a revised or renewal Title V operation permit. Complete for each emissions-limited pollutant identified in Subsection E if applying for an air operation permit.

**Potential, Estimated Fugitive, and Baseline & Projected Actual Emissions**

|  |  |   |  |
|--|--|---|--|
| 1. Pollutant Emitted:<br>HAPS  |  | 2. Total Percent Efficiency of Control:   |  |
| 3. Potential Emissions:<br>0.07 lb/hour                      0.30 tons/year  |  | 4. Synthetically Limited?<br><input type="checkbox"/> Yes <input checked="" type="checkbox"/> No        |  |
| 5. Range of Estimated Fugitive Emissions (as applicable): NA<br>to tons/year   |  |   |  |
| 6. Emission Factor: 0.001027 lb/MM Btu<br><br>Reference: AP-42, Table 3.1-2a   |  | 7. Emissions Method Code:<br>3  |  |
| 8.a. Baseline Actual Emissions (if required):<br>NA tons/year  |  | 8.b. Baseline 24-month Period:<br>From:                      To:  |  |
| 9.a. Projected Actual Emissions (if required):<br>NA tons/year   |  | 9.b. Projected Monitoring Period:<br><input type="checkbox"/> 5 years <input type="checkbox"/> 10 years |  |
| 10. Calculation of Emissions:<br><br>$(0.001027 \text{ lb/MM Btu})(64.50 \text{ MM Btu/hr}) = 0.069 \text{ lb/hr}$<br>$(0.069 \text{ lb/hr})(8760 \text{ hr/yr})(1 \text{ ton}/2000 \text{ lb}) = 0.302 \text{ ton/y}$ |  |   |  |
| 11. Potential, Fugitive, and Actual Emissions Comment:<br><br>Based on vendor's heat input data at ISO conditions with inlet and exhaust losses of 4" of H2O and fuel higher heat value of 1040 Btu/scf                |  |   |  |

**F2. EMISSIONS UNIT POLLUTANT DETAIL INFORMATION -  
 ALLOWABLE EMISSIONS**

**Complete Subsection F2 if the pollutant identified in Subsection F1 is or would be subject to a numerical emissions limitation.**

**Allowable Emissions** Allowable Emissions NA of

|   |  |
|---|--|
| 1. Basis for Allowable Emissions Code:                            | 2. Future Effective Date of Allowable Emissions: NA                          |
| 3. Allowable Emissions and Units:                                 | 4. Equivalent Allowable Emissions:<br>lb/hour                      tons/year |
| 5. Method of Compliance:  |  |
| 6. Allowable Emissions Comment (Description of Operating Method): |  |

**Allowable Emissions** Allowable Emissions \_\_ of \_\_

|   |  |
|---|--|
| 1. Basis for Allowable Emissions Code:                            | 2. Future Effective Date of Allowable Emissions:                             |
| 3. Allowable Emissions and Units:                                 | 4. Equivalent Allowable Emissions:<br>lb/hour                      tons/year |
| 5. Method of Compliance:  |  |
| 6. Allowable Emissions Comment (Description of Operating Method): |  |

**Allowable Emissions** Allowable Emissions \_\_ of \_\_

|   |  |
|---|--|
| 1. Basis for Allowable Emissions Code:                            | 2. Future Effective Date of Allowable Emissions:                             |
| 3. Allowable Emissions and Units:                                 | 4. Equivalent Allowable Emissions:<br>lb/hour                      tons/year |
| 5. Method of Compliance:  |  |
| 6. Allowable Emissions Comment (Description of Operating Method): |  |



**EMISSIONS UNIT INFORMATION**

Section [ 1 ] of [ 4 ]

**G. VISIBLE EMISSIONS INFORMATION**

Complete Subsection G if this emissions unit is or would be subject to a unit-specific visible emissions limitation.

**Visible Emissions Limitation:** Visible Emissions Limitation 1 of 1

|   |  |
|---|--|
| 1. Visible Emissions Subtype:<br>VE10   | 2. Basis for Allowable Opacity:<br><input checked="" type="checkbox"/> Rule <input type="checkbox"/> Other |
| 3. Allowable Opacity:<br>Normal Conditions: 10 %      Exceptional Conditions: %<br>Maximum Period of Excess Opacity Allowed: min/hour |  |
| 3. Method of Compliance:<br>Annual testing with Method 9  |  |
| 4. Visible Emissions Comment:<br><br>Subject to 62-296-320(4)(b) General Visible Emissions Standards.                                 |  |

**Visible Emissions Limitation:** Visible Emissions Limitation    of   

|  |   |
|--|---|
| 1. Visible Emissions Subtype:  | 2. Basis for Allowable Opacity:<br><input type="checkbox"/> Rule <input type="checkbox"/> Other |
| 3. Allowable Opacity:<br>Normal Conditions: %      Exceptional Conditions: %<br>Maximum Period of Excess Opacity Allowed: min/hour |   |
| 4. Method of Compliance:   |   |
| 5. Visible Emissions Comment:  |   |

**EMISSIONS UNIT INFORMATION**

Section [ 1 ] of [ 4 ]

**H. CONTINUOUS MONITOR INFORMATION**

**Complete Subsection H if this emissions unit is or would be subject to continuous monitoring.**

**Continuous Monitoring System:** Continuous Monitor NA of   

|  |  |
|--|--|
| 1. Parameter Code:   | 2. Pollutant(s):   |
| 3. CMS Requirement:  | <input type="checkbox"/> Rule <input type="checkbox"/> Other |
| 4. Monitor Information...<br>Manufacturer:<br>Model Number: Serial Number: |  |
| 5. Installation Date:  | 6. Performance Specification Test Date:                      |
| 7. Continuous Monitor Comment:   |  |

**Continuous Monitoring System:** Continuous Monitor    of   

|  |  |
|--|--|
| 1. Parameter Code:   | 2. Pollutant(s):   |
| 3. CMS Requirement:  | <input type="checkbox"/> Rule <input type="checkbox"/> Other |
| 4. Monitor Information...<br>Manufacturer:<br>Model Number: Serial Number: |  |
| 5. Installation Date:  | 6. Performance Specification Test Date:                      |
| 7. Continuous Monitor Comment:   |  |

**EMISSIONS UNIT INFORMATION**

Section | 1 | of | 4 |

**I. EMISSIONS UNIT ADDITIONAL INFORMATION**

**Additional Requirements for All Applications, Except as Otherwise Stated**

|   |
|---|
| 1. Process Flow Diagram: (Required for all permit applications, except Title V air operation permit revision applications if this information was submitted to the department within the previous five years and would not be altered as a result of the revision being sought)<br><input checked="" type="checkbox"/> Attached, Document ID: <u>Attach. B</u> <input type="checkbox"/> Previously Submitted, Date _____  |
| 2. Fuel Analysis or Specification: (Required for all permit applications, except Title V air operation permit revision applications if this information was submitted to the department within the previous five years and would not be altered as a result of the revision being sought)<br><input checked="" type="checkbox"/> Attached, Document ID: <u>Attach. G</u> <input type="checkbox"/> Previously Submitted, Date _____  |
| 3. Detailed Description of Control Equipment: (Required for all permit applications, except Title V air operation permit revision applications if this information was submitted to the department within the previous five years and would not be altered as a result of the revision being sought)<br><input type="checkbox"/> Attached, Document ID: <u>NA</u> <input type="checkbox"/> Previously Submitted, Date _____   |
| 4. Procedures for Startup and Shutdown: (Required for all operation permit applications, except Title V air operation permit revision applications if this information was submitted to the department within the previous five years and would not be altered as a result of the revision being sought)<br><input type="checkbox"/> Attached, Document ID: _____ <input type="checkbox"/> Previously Submitted, Date _____<br><input checked="" type="checkbox"/> Not Applicable (construction application)  |
| 5. Operation and Maintenance Plan: (Required for all permit applications, except Title V air operation permit revision applications if this information was submitted to the department within the previous five years and would not be altered as a result of the revision being sought)<br><input type="checkbox"/> Attached, Document ID: _____ <input type="checkbox"/> Previously Submitted, Date _____<br><input checked="" type="checkbox"/> Not Applicable  |
| 6. Compliance Demonstration Reports/Records:<br><input type="checkbox"/> Attached, Document ID: _____<br>Test Date(s)/Pollutant(s) Tested: _____<br><input type="checkbox"/> Previously Submitted, Date: _____<br>Test Date(s)/Pollutant(s) Tested: _____<br><input type="checkbox"/> To be Submitted, Date (if known): _____<br>Test Date(s)/Pollutant(s) Tested: _____<br><input checked="" type="checkbox"/> Not Applicable<br>Note: For FESOP applications, all required compliance demonstration records/reports must be submitted at the time of application. For Title V air operation permit applications, all required compliance demonstration reports/records must be submitted at the time of application, or a compliance plan must be submitted at the time of application. |
| 7. Other Information Required by Rule or Statute:<br><input type="checkbox"/> Attached, Document ID: _____ <input checked="" type="checkbox"/> Not Applicable   |

**EMISSIONS UNIT INFORMATION**

Section [ 1 ] of [ 4 ]

**I. EMISSIONS UNIT ADDITIONAL INFORMATION (CONTINUED)**

**Additional Requirements for Air Construction Permit Applications**

|  |
|--|
| 1. Control Technology Review and Analysis (Rules 62-212.400(10) and 62-212.500(7), F.A.C.; 40 CFR 63.43(d) and (e)):<br><input checked="" type="checkbox"/> Attached, Document ID: <u>Narr. Sec. 3.0</u> <input type="checkbox"/> Not Applicable |
| 2. Good Engineering Practice Stack Height Analysis (Rules 62-212.400(4)(d) and 62-212.500(4)(f), F.A.C.):<br><input type="checkbox"/> Attached, Document ID: _____ <input checked="" type="checkbox"/> Not Applicable                            |
| 3. Description of Stack Sampling Facilities: (Required for proposed new stack sampling facilities only)<br><input checked="" type="checkbox"/> Attached, Document ID: <u>See Note Below</u> <input type="checkbox"/> Not Applicable              |

**Additional Requirements for Title V Air Operation Permit Applications**

|   |
|---|
| 1. Identification of Applicable Requirements:<br><input type="checkbox"/> Attached, Document ID: <u>NA</u>  |
| 2. Compliance Assurance Monitoring:<br><input type="checkbox"/> Attached, Document ID: _____ <input type="checkbox"/> Not Applicable                    |
| 3. Alternative Methods of Operation:<br><input type="checkbox"/> Attached, Document ID: _____ <input type="checkbox"/> Not Applicable                   |
| 4. Alternative Modes of Operation (Emissions Trading):<br><input type="checkbox"/> Attached, Document ID: _____ <input type="checkbox"/> Not Applicable |

**Additional Requirements Comment**

Supplemental information is provided in the narrative description accompanying these forms.

Specifications for the engine silencers/stacks have not been completed at this time. Final specifications will comply with USEPA and FDEP regulatory requirements.

**EMISSIONS UNIT INFORMATION**

Section [ 2 ] of [ 4 ]

**A. GENERAL EMISSIONS UNIT INFORMATION**

**Title V Air Operation Permit Emissions Unit Classification**

1. Regulated or Unregulated Emissions Unit? (Check one, if applying for an initial, revised or renewal Title V air operation permit. Skip this item if applying for an air construction permit or FESOP only.) NA

The emissions unit addressed in this Emissions Unit Information Section is a regulated emissions unit.

The emissions unit addressed in this Emissions Unit Information Section is an unregulated emissions unit.

**Emissions Unit Description and Status**

1. Type of Emissions Unit Addressed in this Section: (Check one)

This Emissions Unit Information Section addresses, as a single emissions unit, a single process or production unit, or activity, which produces one or more air pollutants and which has at least one definable emission point (stack or vent).

This Emissions Unit Information Section addresses, as a single emissions unit, a group of process or production units and activities which has at least one definable emission point (stack or vent) but may also produce fugitive emissions.

This Emissions Unit Information Section addresses, as a single emissions unit, one or more process or production units and activities which produce fugitive emissions only.

1. Description of Emissions Unit Addressed in this Section:

7,800 bhp (ISO) natural gas fired turbine compressor unit, FGT Engine No. 2902

3. Emissions Unit Identification Number: 002

|   |  |                                    |   |
|---|--|------------------------------------|---|
| 4. Emissions Unit Status Code:<br><br>C | 5. Commence Construction Date:<br><br>NA | 6. Initial Startup Date:<br><br>NA | 7. Emissions Unit Major Group SIC Code:<br><br>49 |
|---|--|------------------------------------|---|

8. Federal Program Applicability: (Check all that apply)

Acid Rain Unit

CAIR Unit

Hg Budget Unit

9. Package Unit:  
Manufacturer: Solar  
Model Number: Taurus 60 - 7800S

10. Generator Nameplate Rating: MW

11. Emissions Unit Comment:

Fuel will be exclusively natural gas from the FGT's gas pipeline. The proposed engine will incorporate dry, low NO<sub>x</sub> combustion technology.

**EMISSIONS UNIT INFORMATION**

Section | 2 | of | 4 |

**Emissions Unit Control Equipment/Method:** Control 1 of 1

1. Control Equipment/Method Description:

The proposed engine will incorporate dry, low NO<sub>x</sub> combustion technology.

2. Control Device or Method Code: 99

**Emissions Unit Control Equipment/Method:** Control    of   

1. Control Equipment/Method Description:

2. Control Device or Method Code:

**Emissions Unit Control Equipment/Method:** Control    of   

1. Control Equipment/Method Description:

2. Control Device or Method Code:

**Emissions Unit Control Equipment/Method:** Control    of   

1. Control Equipment/Method Description:

2. Control Device or Method Code:

**EMISSIONS UNIT INFORMATION**

Section [ 2 ] of [ 4 ]

**B. EMISSIONS UNIT CAPACITY INFORMATION**

(Optional for unregulated emissions units.)

**Emissions Unit Operating Capacity and Schedule**

|   |
|---|
| 1. Maximum Process or Throughput Rate: NA   |
| 2. Maximum Production Rate: NA  |
| 3. Maximum Heat Input Rate: 67.09 million Btu/hr HHV  |
| 4. Maximum Incineration Rate: pounds/hr NA<br>tons/day  |
| 5. Requested Maximum Operating Schedule:<br>24 hours/day 7 days/week<br>52 weeks/year 8760 hours/year   |
| 6. Operating Capacity/Schedule Comment:<br><br>Heat input is 56.09 MM Btu/hr Higher heating value (HHV). This is based on a vendor provided bhp of 7,277 bhp, a specific heat rate of 8,326 Btu/hp-hr, a lower heating value (LHV) of 939.2 Btu/scf and a higher heating value (HHV) of 1040 Btu/scf. |

**EMISSIONS UNIT INFORMATION**

Section | 2 | of | 4 |

**C. EMISSION POINT (STACK/VENT) INFORMATION****(Optional for unregulated emissions units.)****Emission Point Description and Type**

|   |   |   |  |
|---|---|---|--|
| 1. Identification of Point on Plot Plan or Flow Diagram: 2902                                 |   | 2. Emission Point Type Code:<br>1   |  |
| 3. Descriptions of Emission Points Comprising this Emissions Unit for VE Tracking:<br><br>NA  |   |   |  |
| 4. ID Numbers or Descriptions of Emission Units with this Emission Point in Common:<br><br>NA |   |   |  |
| 5. Discharge Type Code:<br>V  | 6. Stack Height:<br>55 Feet                     | 7. Exit Diameter:<br>6.0 feet   |  |
| 8. Exit Temperature:<br>956 °F  | 9. Actual Volumetric Flow Rate:<br>101,546 acfm | 10. Water Vapor:<br>NA %  |  |
| 11. Maximum Dry Standard Flow Rate:<br>NA dscfm   |   | 12. Nonstack Emission Point Height:<br>NA feet  |  |
| 13. Emission Point UTM Coordinates...<br>Zone: 17 East (km): 494.3<br>North (km): 3012.4      |   | 14. Emission Point Latitude/Longitude...<br>Latitude (DD/MM/SS)<br>Longitude (DD/MM/SS) |  |
| 15. Emission Point Comment:<br><br>None   |   |   |  |



**EMISSIONS UNIT INFORMATION**

Section | 2 | of | 4 |

**D. SEGMENT (PROCESS/FUEL) INFORMATION****Segment Description and Rate:** Segment 1 of 1

|  |                                   |  |
|--|-----------------------------------|--|
| 1. Segment Description (Process/Fuel Type):<br><br>Natural gas fired turbine engine driving a natural gas compressor, operating full time. |                                   |  |
| 2. Source Classification Code (SCC):<br>2-02-002-01  |                                   | 3. SCC Units:<br>million cubic feet burned |
| 4. Maximum Hourly Rate:<br>0.0645  | 5. Maximum Annual Rate:<br>565.10 | 6. Estimated Annual Activity Factor: NA    |
| 7. Maximum % Sulfur:<br>NA   | 8. Maximum % Ash:<br>NA           | 9. Million Btu per SCC Unit:<br>1040       |
| 10. Segment Comment:<br><br>None   |                                   |  |

**Segment Description and Rate:** Segment    of   

|   |                         |                                      |
|---|-------------------------|--------------------------------------|
| 1. Segment Description (Process/Fuel Type):<br><br> |                         |                                      |
| 2. Source Classification Code (SCC):                |                         | 3. SCC Units:                        |
| 4. Maximum Hourly Rate:                             | 5. Maximum Annual Rate: | 6. Estimated Annual Activity Factor: |
| 7. Maximum % Sulfur:                                | 8. Maximum % Ash:       | 9. Million Btu per SCC Unit:         |
| 10. Segment Comment:<br><br>                        |                         |                                      |



**EMISSIONS UNIT INFORMATION**

Section [ 2 ] of [ 4 ]

**POLLUTANT DETAIL INFORMATION**

Page [ 1 ] of [ 6 ]

**F1. EMISSIONS UNIT POLLUTANT DETAIL INFORMATION –  
POTENTIAL, FUGITIVE, AND ACTUAL EMISSIONS  
(Optional for unregulated emissions units.)**

Complete a Subsection F1 for each pollutant identified in Subsection E if applying for an air construction permit or concurrent processing of an air construction permit and a revised or renewal Title V operation permit. Complete for each emissions-limited pollutant identified in Subsection E if applying for an air operation permit.

**Potential, Estimated Fugitive, and Baseline & Projected Actual Emissions**

|   |  |   |  |
|---|--|---|--|
| 1. Pollutant Emitted:<br>NOX  |  | 2. Total Percent Efficiency of Control:   |  |
| 3. Potential Emissions:<br>6.04 lb/hour                      26.46 tons/year  |  | 4. Synthetically Limited?<br><input type="checkbox"/> Yes <input checked="" type="checkbox"/> No        |  |
| 5. Range of Estimated Fugitive Emissions (as applicable): NA<br>to tons/year  |  |   |  |
| 6. Emission Factor: 6.04 lb/hr<br><br>Reference: Vendor data  |  | 7. Emissions Method Code:<br>5  |  |
| 8.a. Baseline Actual Emissions (if required):<br>NA tons/year   |  | 8.b. Baseline 24-month Period:<br>From:                      To:  |  |
| 9.a. Projected Actual Emissions (if required):<br>NA tons/year  |  | 9.b. Projected Monitoring Period:<br><input type="checkbox"/> 5 years <input type="checkbox"/> 10 years |  |
| 10. Calculation of Emissions:<br><br>(6.04 lb/hr)(1 ton/2000 lb)(8760hr/1 yr) = 26.46 tons/year   |  |   |  |
| 11. Potential, Fugitive, and Actual Emissions Comment:<br><br>Vendor's data based on ISO conditions with inlet and exhaust losses of 4" of H2O. |  |   |  |

**F2. EMISSIONS UNIT POLLUTANT DETAIL INFORMATION -  
 ALLOWABLE EMISSIONS**

**Complete Subsection F2 if the pollutant identified in Subsection F1 is or would be subject to a numerical emissions limitation.**

**Allowable Emissions** Allowable Emissions  1  of  1

|   |   |
|---|---|
| 1. Basis for Allowable Emissions Code:<br>RULE  | 2. Future Effective Date of Allowable Emissions: NA                     |
| 3. Allowable Emissions and Units:<br>25 ppmvd @ 15% O2  | 4. Equivalent Allowable Emissions:<br>6.04 lb/hour      26.46 tons/year |
| 5. Method of Compliance:<br>Initial performance test  |   |
| 6. Allowable Emissions Comment (Description of Operating Method):<br><br>40 CFR 60.4320(a) limits NOX emissions to 25 ppmv. |   |

**Allowable Emissions** Allowable Emissions   of

|   |  |
|---|--|
| 1. Basis for Allowable Emissions Code:                            | 2. Future Effective Date of Allowable Emissions:             |
| 3. Allowable Emissions and Units:                                 | 4. Equivalent Allowable Emissions:<br>lb/hour      tons/year |
| 5. Method of Compliance:  |  |
| 6. Allowable Emissions Comment (Description of Operating Method): |  |

**Allowable Emissions** Allowable Emissions   of

|   |  |
|---|--|
| 1. Basis for Allowable Emissions Code:                            | 2. Future Effective Date of Allowable Emissions:             |
| 3. Allowable Emissions and Units:                                 | 4. Equivalent Allowable Emissions:<br>lb/hour      tons/year |
| 5. Method of Compliance:  |  |
| 6. Allowable Emissions Comment (Description of Operating Method): |  |

**EMISSIONS UNIT INFORMATION**

Section | 2 | of | 4 |

**POLLUTANT DETAIL INFORMATION**

Page | 2 | of | 6 |

**F1. EMISSIONS UNIT POLLUTANT DETAIL INFORMATION –  
POTENTIAL, FUGITIVE, AND ACTUAL EMISSIONS  
(Optional for unregulated emissions units.)**

Complete a Subsection F1 for each pollutant identified in Subsection E if applying for an air construction permit or concurrent processing of an air construction permit and a revised or renewal Title V operation permit. Complete for each emissions-limited pollutant identified in Subsection E if applying for an air operation permit.

**Potential, Estimated Fugitive, and Baseline & Projected Actual Emissions**

|  |  |   |  |
|--|--|---|--|
| 1. Pollutant Emitted:<br>CO  |  | 2. Total Percent Efficiency of Control:   |  |
| 3. Potential Emissions:<br>7.35 lb/hour                      32.19 tons/year   |  | 4. Synthetically Limited?<br><input type="checkbox"/> Yes <input checked="" type="checkbox"/> No        |  |
| 5. Range of Estimated Fugitive Emissions (as applicable): NA<br>to tons/year   |  |   |  |
| 6. Emission Factor: 7.35 lb/hr<br><br>Reference: Vendor data   |  | 7. Emissions Method Code:<br>5  |  |
| 8.a. Baseline Actual Emissions (if required):<br>NA tons/year  |  | 8.b. Baseline 24-month Period:<br>From:                      To:  |  |
| 9.a. Projected Actual Emissions (if required):<br>NA tons/year   |  | 9.b. Projected Monitoring Period:<br><input type="checkbox"/> 5 years <input type="checkbox"/> 10 years |  |
| 10. Calculation of Emissions:<br><br>$(7.35 \text{ lb/hr})(1 \text{ ton}/2000 \text{ lb})(8760\text{hr}/1 \text{ yr}) = 32.19 \text{ tons/year}$ |  |   |  |
| 11. Potential, Fugitive, and Actual Emissions Comment:<br><br>Vendor's data based on ISO conditions with inlet and exhaust losses of 4" of H2O.  |  |   |  |

**EMISSIONS UNIT INFORMATION**

Section | 2 | of | 4 |

**POLLUTANT DETAIL INFORMATION**

Page | 2 | of | 6 |

**F2. EMISSIONS UNIT POLLUTANT DETAIL INFORMATION -  
ALLOWABLE EMISSIONS****Complete Subsection F2 if the pollutant identified in Subsection F1 is or would be subject to a numerical emissions limitation.****Allowable Emissions** Allowable Emissions NA of

|   |  |
|---|--|
| 1. Basis for Allowable Emissions Code:                            | 2. Future Effective Date of Allowable Emissions: NA                          |
| 3. Allowable Emissions and Units:                                 | 4. Equivalent Allowable Emissions:<br>lb/hour                      tons/year |
| 5. Method of Compliance:  |  |
| 6. Allowable Emissions Comment (Description of Operating Method): |  |

**Allowable Emissions** Allowable Emissions    of   

|   |  |
|---|--|
| 1. Basis for Allowable Emissions Code:                            | 2. Future Effective Date of Allowable Emissions:                             |
| 3. Allowable Emissions and Units:                                 | 4. Equivalent Allowable Emissions:<br>lb/hour                      tons/year |
| 5. Method of Compliance:  |  |
| 6. Allowable Emissions Comment (Description of Operating Method): |  |

**Allowable Emissions** Allowable Emissions    of   

|   |  |
|---|--|
| 1. Basis for Allowable Emissions Code:                            | 2. Future Effective Date of Allowable Emissions:                             |
| 3. Allowable Emissions and Units:                                 | 4. Equivalent Allowable Emissions:<br>lb/hour                      tons/year |
| 5. Method of Compliance:  |  |
| 6. Allowable Emissions Comment (Description of Operating Method): |  |

**EMISSIONS UNIT INFORMATION**

Section [ 2 ] of [ 4 ]

**POLLUTANT DETAIL INFORMATION**

Page [ 3 ] of [ 6 ]

**F1. EMISSIONS UNIT POLLUTANT DETAIL INFORMATION –  
POTENTIAL, FUGITIVE, AND ACTUAL EMISSIONS  
(Optional for unregulated emissions units.)**

**Complete a Subsection F1 for each pollutant identified in Subsection E if applying for an air construction permit or concurrent processing of an air construction permit and a revised or renewal Title V operation permit. Complete for each emissions-limited pollutant identified in Subsection E if applying for an air operation permit.**

**Potential, Estimated Fugitive, and Baseline & Projected Actual Emissions**

|   |  |   |  |
|---|--|---|--|
| 1. Pollutant Emitted:<br>VOC  |  | 2. Total Percent Efficiency of Control:   |  |
| 3. Potential Emissions:<br>0.21 lb/hour                      0.92 tons/year   |  | 4. Synthetically Limited?<br><input type="checkbox"/> Yes <input checked="" type="checkbox"/> No        |  |
| 5. Range of Estimated Fugitive Emissions (as applicable): NA<br>to tons/year  |  |   |  |
| 6. Emission Factor: 0.21 lb/hr<br><br>Reference: Vendor data  |  | 7. Emissions Method Code:<br>5  |  |
| 8.a. Baseline Actual Emissions (if required):<br>NA tons/year   |  | 8.b. Baseline 24-month Period:<br>From:                      To:  |  |
| 9.a. Projected Actual Emissions (if required):<br>NA tons/year  |  | 9.b. Projected Monitoring Period:<br><input type="checkbox"/> 5 years <input type="checkbox"/> 10 years |  |
| 10. Calculation of Emissions:<br><br>UHC = 2.11 lb/hr, assume VOC = 10% UHC<br>(0.21 lb/hr)(1 ton/2000 lb)(8760hr/1 yr) = 0.92 tons/year        |  |   |  |
| 11. Potential, Fugitive, and Actual Emissions Comment:<br><br>Vendor's data based on ISO conditions with inlet and exhaust losses of 4" of H2O. |  |   |  |

**EMISSIONS UNIT INFORMATION**

Section | 2 | of | 4 |

**POLLUTANT DETAIL INFORMATION**

Page | 3 | of | 6 |

**F2. EMISSIONS UNIT POLLUTANT DETAIL INFORMATION -  
ALLOWABLE EMISSIONS****Complete Subsection F2 if the pollutant identified in Subsection F1 is or would be subject to a numerical emissions limitation.****Allowable Emissions** Allowable Emissions NA of

|   |  |
|---|--|
| 1. Basis for Allowable Emissions Code:                            | 2. Future Effective Date of Allowable Emissions:                             |
| 3. Allowable Emissions and Units:                                 | 4. Equivalent Allowable Emissions:<br>lb/hour                      tons/year |
| 5. Method of Compliance:  |  |
| 6. Allowable Emissions Comment (Description of Operating Method): |  |

**Allowable Emissions** Allowable Emissions \_\_ of \_\_

|   |  |
|---|--|
| 1. Basis for Allowable Emissions Code:                            | 2. Future Effective Date of Allowable Emissions:                             |
| 3. Allowable Emissions and Units:                                 | 4. Equivalent Allowable Emissions:<br>lb/hour                      tons/year |
| 5. Method of Compliance:  |  |
| 6. Allowable Emissions Comment (Description of Operating Method): |  |

**Allowable Emissions** Allowable Emissions \_\_ of \_\_

|   |  |
|---|--|
| 1. Basis for Allowable Emissions Code:                            | 2. Future Effective Date of Allowable Emissions:                             |
| 3. Allowable Emissions and Units:                                 | 4. Equivalent Allowable Emissions:<br>lb/hour                      tons/year |
| 5. Method of Compliance:  |  |
| 6. Allowable Emissions Comment (Description of Operating Method): |  |



**EMISSIONS UNIT INFORMATION**

Section [ 2 ] of [ 4 ]

**POLLUTANT DETAIL INFORMATION**

Page [ 4 ] of [ 6 ]

**F1. EMISSIONS UNIT POLLUTANT DETAIL INFORMATION –  
POTENTIAL, FUGITIVE, AND ACTUAL EMISSIONS  
(Optional for unregulated emissions units.)**

**Complete a Subsection F1 for each pollutant identified in Subsection E if applying for an air construction permit or concurrent processing of an air construction permit and a revised or renewal Title V operation permit. Complete for each emissions-limited pollutant identified in Subsection E if applying for an air operation permit.**

**Potential, Estimated Fugitive, and Baseline & Projected Actual Emissions**

|  |  |   |  |
|--|--|---|--|
| 1. Pollutant Emitted:<br>SO2   |  | 2. Total Percent Efficiency of Control:   |  |
| 3. Potential Emissions:<br>1.84 lb/hour                      8.07 tons/year  |  | 4. Synthetically Limited?<br><input type="checkbox"/> Yes <input checked="" type="checkbox"/> No        |  |
| 5. Range of Estimated Fugitive Emissions (as applicable): NA<br>to tons/year   |  |   |  |
| 6. Emission Factor: 10 grain/100 scf<br><br>Reference: FERC limit  |  | 7. Emissions Method Code:<br>2  |  |
| 8.a. Baseline Actual Emissions (if required):<br>NA tons/year  |  | 8.b. Baseline 24-month Period:<br>From:                      To:  |  |
| 9.a. Projected Actual Emissions (if required):<br>NA tons/year   |  | 9.b. Projected Monitoring Period:<br><input type="checkbox"/> 5 years <input type="checkbox"/> 10 years |  |
| 10. Calculation of Emissions:<br><br>$(10 \text{ gr S}/100 \text{ scf})(64,500 \text{ scf/hr})(1 \text{ lb}/7000 \text{ gr}) = 0.921 \text{ lb S/hr}$ $(0.921 \text{ lb S/hr})(2 \text{ lb SO}_2/\text{lb S}) = 1.843 \text{ lb SO}_2/\text{hr}$ $(1.843 \text{ lb SO}_2/\text{hr})(8760 \text{ hr/yr})(1 \text{ ton}/2000 \text{ lb}) = 8.073 \text{ ton/yr}$ |  |   |  |
| 11. Potential, Fugitive, and Actual Emissions Comment:<br><br>Vendor's data based on ISO conditions with inlet and exhaust losses of 4" of H2O.  |  |   |  |

**EMISSIONS UNIT INFORMATION**

Section [ 2 ] of [ 4 ]

**POLLUTANT DETAIL INFORMATION**

Page [ 4 ] of [ 6 ]

**F2. EMISSIONS UNIT POLLUTANT DETAIL INFORMATION -  
ALLOWABLE EMISSIONS****Complete Subsection F2 if the pollutant identified in Subsection F1 is or would be subject to a numerical emissions limitation.****Allowable Emissions** Allowable Emissions 1 of 1

|   |  |
|---|--|
| 1. Basis for Allowable Emissions Code:<br>RULE  | 2. Future Effective Date of Allowable Emissions: NA                    |
| 3. Allowable Emissions and Units:   | 4. Equivalent Allowable Emissions:<br>1.84 lb/hour      8.07 tons/year |
| 5. Method of Compliance:<br>Initial performance test  |  |
| 6. Allowable Emissions Comment (Description of Operating Method):<br><br>40 CFR 60.4330(a)(2) limits SO2 emissions to 4.03 lb/hr. |  |

**Allowable Emissions** Allowable Emissions    of   

|   |  |
|---|--|
| 1. Basis for Allowable Emissions Code:                            | 2. Future Effective Date of Allowable Emissions:             |
| 3. Allowable Emissions and Units:                                 | 4. Equivalent Allowable Emissions:<br>lb/hour      tons/year |
| 5. Method of Compliance:  |  |
| 6. Allowable Emissions Comment (Description of Operating Method): |  |

**Allowable Emissions** Allowable Emissions    of   

|   |  |
|---|--|
| 1. Basis for Allowable Emissions Code:                            | 2. Future Effective Date of Allowable Emissions:             |
| 3. Allowable Emissions and Units:                                 | 4. Equivalent Allowable Emissions:<br>lb/hour      tons/year |
| 5. Method of Compliance:  |  |
| 6. Allowable Emissions Comment (Description of Operating Method): |  |

**EMISSIONS UNIT INFORMATION**

Section [ 2 ] of [ 4 ]

**POLLUTANT DETAIL INFORMATION**

Page [ 5 ] of [ 6 ]

**F1. EMISSIONS UNIT POLLUTANT DETAIL INFORMATION –  
POTENTIAL, FUGITIVE, AND ACTUAL EMISSIONS**

(Optional for unregulated emissions units.)

Complete a Subsection F1 for each pollutant identified in Subsection E if applying for an air construction permit or concurrent processing of an air construction permit and a revised or renewal Title V operation permit. Complete for each emissions-limited pollutant identified in Subsection E if applying for an air operation permit.

**Potential, Estimated Fugitive, and Baseline & Projected Actual Emissions**

|   |  |   |  |
|---|--|---|--|
| 1. Pollutant Emitted:<br>PM   |  | 2. Total Percent Efficiency of Control:   |  |
| 3. Potential Emissions:<br>0.44 lb/hour                      1.94 tons/year   |  | 4. Synthetically Limited?<br><input type="checkbox"/> Yes <input checked="" type="checkbox"/> No        |  |
| 5. Range of Estimated Fugitive Emissions (as applicable): NA<br>to tons/year  |  |   |  |
| 6. Emission Factor: 0.0066 lb/MM Btu<br><br>Reference: Table 3.1-2a, AP-42 4/00   |  | 7. Emissions Method Code:<br>3  |  |
| 8.a. Baseline Actual Emissions (if required):<br>NA tons/year   |  | 8.b. Baseline 24-month Period:<br>From:                      To:  |  |
| 9.a. Projected Actual Emissions (if required):<br>NA tons/year  |  | 9.b. Projected Monitoring Period:<br><input type="checkbox"/> 5 years <input type="checkbox"/> 10 years |  |
| 10. Calculation of Emissions:<br><br>$(0.0066 \text{ lb/MM Btu})(64.50 \text{ MM Btu/hr}) = 0.443 \text{ lb/hr}$ $(0.443 \text{ lb/hr})(8760 \text{ hr/yr})(1 \text{ ton}/2000 \text{ lb}) = 1.939 \text{ ton/y}$ |  |   |  |
| 11. Potential, Fugitive, and Actual Emissions Comment:<br><br>Based on vendor's heat input data at ISO conditions with inlet and exhaust losses of 4" of H2O and fuel higher heat value of 1040 Btu/scf           |  |   |  |

**F2. EMISSIONS UNIT POLLUTANT DETAIL INFORMATION -  
 ALLOWABLE EMISSIONS**

**Complete Subsection F2 if the pollutant identified in Subsection F1 is or would be subject to a numerical emissions limitation.**

**Allowable Emissions** Allowable Emissions NA of

|   |  |
|---|--|
| 1. Basis for Allowable Emissions Code:                            | 2. Future Effective Date of Allowable Emissions: NA                          |
| 3. Allowable Emissions and Units:                                 | 4. Equivalent Allowable Emissions:<br>lb/hour                      tons/year |
| 5. Method of Compliance:  |  |
| 6. Allowable Emissions Comment (Description of Operating Method): |  |

**Allowable Emissions** Allowable Emissions \_\_ of \_\_

|   |  |
|---|--|
| 1. Basis for Allowable Emissions Code:                            | 2. Future Effective Date of Allowable Emissions:                             |
| 3. Allowable Emissions and Units:                                 | 4. Equivalent Allowable Emissions:<br>lb/hour                      tons/year |
| 5. Method of Compliance:  |  |
| 6. Allowable Emissions Comment (Description of Operating Method): |  |

**Allowable Emissions** Allowable Emissions \_\_ of \_\_

|   |  |
|---|--|
| 1. Basis for Allowable Emissions Code:                            | 2. Future Effective Date of Allowable Emissions:                             |
| 3. Allowable Emissions and Units:                                 | 4. Equivalent Allowable Emissions:<br>lb/hour                      tons/year |
| 5. Method of Compliance:  |  |
| 6. Allowable Emissions Comment (Description of Operating Method): |  |

**EMISSIONS UNIT INFORMATION**

Section [ 2 ] of [ 4 ]

**POLLUTANT DETAIL INFORMATION**

Page [ 6 ] of [ 6 ]

**F1. EMISSIONS UNIT POLLUTANT DETAIL INFORMATION –  
POTENTIAL, FUGITIVE, AND ACTUAL EMISSIONS  
(Optional for unregulated emissions units.)**

**Complete a Subsection F1 for each pollutant identified in Subsection E if applying for an air construction permit or concurrent processing of an air construction permit and a revised or renewal Title V operation permit. Complete for each emissions-limited pollutant identified in Subsection E if applying for an air operation permit.**

**Potential, Estimated Fugitive, and Baseline & Projected Actual Emissions**

|  |  |   |  |
|--|--|---|--|
| 1. Pollutant Emitted:<br>HAPS  |  | 2. Total Percent Efficiency of Control:   |  |
| 3. Potential Emissions:<br>0.07 lb/hour                      0.30 tons/year  |  | 4. Synthetically Limited?<br><input type="checkbox"/> Yes <input checked="" type="checkbox"/> No        |  |
| 5. Range of Estimated Fugitive Emissions (as applicable): NA<br>to tons/year   |  |   |  |
| 6. Emission Factor: 0.001027 lb/MM Btu<br><br>Reference: AP-42, Table 3.1-2a   |  | 7. Emissions Method Code:<br>3  |  |
| 8.a. Baseline Actual Emissions (if required):<br>NA tons/year  |  | 8.b. Baseline 24-month Period:<br>From:                      To:  |  |
| 9.a. Projected Actual Emissions (if required):<br>NA tons/year   |  | 9.b. Projected Monitoring Period:<br><input type="checkbox"/> 5 years <input type="checkbox"/> 10 years |  |
| 10. Calculation of Emissions:<br><br>$(0.001027 \text{ lb/MM Btu})(64.50 \text{ MM Btu/hr}) = 0.069 \text{ lb/hr}$<br>$(0.069 \text{ lb/hr})(8760 \text{ hr/yr})(1 \text{ ton}/2000 \text{ lb}) = 0.302 \text{ ton/y}$ |  |   |  |
| 11. Potential, Fugitive, and Actual Emissions Comment:<br><br>Based on vendor's heat input data at ISO conditions with inlet and exhaust losses of 4" of H2O and fuel higher heat value of 1040 Btu/scf                |  |   |  |

**F2. EMISSIONS UNIT POLLUTANT DETAIL INFORMATION -  
 ALLOWABLE EMISSIONS**

**Complete Subsection F2 if the pollutant identified in Subsection F1 is or would be subject to a numerical emissions limitation.**

**Allowable Emissions** Allowable Emissions NA of

|   |  |
|---|--|
| 1. Basis for Allowable Emissions Code:                            | 2. Future Effective Date of Allowable Emissions: NA                          |
| 3. Allowable Emissions and Units:                                 | 4. Equivalent Allowable Emissions:<br>lb/hour                      tons/year |
| 5. Method of Compliance:  |  |
| 6. Allowable Emissions Comment (Description of Operating Method): |  |

**Allowable Emissions** Allowable Emissions \_\_ of \_\_

|   |  |
|---|--|
| 1. Basis for Allowable Emissions Code:                            | 2. Future Effective Date of Allowable Emissions:                             |
| 3. Allowable Emissions and Units:                                 | 4. Equivalent Allowable Emissions:<br>lb/hour                      tons/year |
| 5. Method of Compliance:  |  |
| 6. Allowable Emissions Comment (Description of Operating Method): |  |

**Allowable Emissions** Allowable Emissions \_\_ of \_\_

|   |  |
|---|--|
| 1. Basis for Allowable Emissions Code:                            | 2. Future Effective Date of Allowable Emissions:                             |
| 3. Allowable Emissions and Units:                                 | 4. Equivalent Allowable Emissions:<br>lb/hour                      tons/year |
| 5. Method of Compliance:  |  |
| 6. Allowable Emissions Comment (Description of Operating Method): |  |

**EMISSIONS UNIT INFORMATION**

Section [ 2 ] of [ 4 ]

**G. VISIBLE EMISSIONS INFORMATION**

**Complete Subsection G if this emissions unit is or would be subject to a unit-specific visible emissions limitation.**

**Visible Emissions Limitation:** Visible Emissions Limitation 1 of 1

|   |  |
|---|--|
| 1. Visible Emissions Subtype:<br>VE10   | 2. Basis for Allowable Opacity:<br><input checked="" type="checkbox"/> Rule <input type="checkbox"/> Other |
| 3. Allowable Opacity:<br>Normal Conditions: 10 %      Exceptional Conditions: %<br>Maximum Period of Excess Opacity Allowed: min/hour |  |
| 2. Method of Compliance:<br>Annual testing with Method 9  |  |
| 3. Visible Emissions Comment:<br><br>Subject to 62-296-320(4)(b) General Visible Emissions Standards.                                 |  |

**Visible Emissions Limitation:** Visible Emissions Limitation    of   

|  |   |
|--|---|
| 1. Visible Emissions Subtype:  | 2. Basis for Allowable Opacity:<br><input type="checkbox"/> Rule <input type="checkbox"/> Other |
| 3. Allowable Opacity:<br>Normal Conditions: %      Exceptional Conditions: %<br>Maximum Period of Excess Opacity Allowed: min/hour |   |
| 4. Method of Compliance:   |   |
| 5. Visible Emissions Comment:  |   |

**EMISSIONS UNIT INFORMATION**

Section | 2 | of | 4 |

**H. CONTINUOUS MONITOR INFORMATION**

**Complete Subsection H if this emissions unit is or would be subject to continuous monitoring.**

**Continuous Monitoring System:** Continuous Monitor NA of   

|   |  |
|---|--|
| 1. Parameter Code:  | 2. Pollutant(s):   |
| 3. CMS Requirement:   | <input type="checkbox"/> Rule <input type="checkbox"/> Other |
| 4. Monitor Information...<br>Manufacturer:<br>Model Number: | Serial Number:   |
| 5. Installation Date:                                       | 6. Performance Specification Test Date:                      |
| 7. Continuous Monitor Comment:                              |  |

**Continuous Monitoring System:** Continuous Monitor    of   

|   |  |
|---|--|
| 1. Parameter Code:  | 2. Pollutant(s):   |
| 3. CMS Requirement:   | <input type="checkbox"/> Rule <input type="checkbox"/> Other |
| 4. Monitor Information...<br>Manufacturer:<br>Model Number: | Serial Number:   |
| 5. Installation Date:                                       | 6. Performance Specification Test Date:                      |
| 7. Continuous Monitor Comment:                              |  |



**EMISSIONS UNIT INFORMATION**

Section | 2 | of | 4 |

**I. EMISSIONS UNIT ADDITIONAL INFORMATION**

**Additional Requirements for All Applications, Except as Otherwise Stated**

|   |
|---|
| 1. Process Flow Diagram: (Required for all permit applications, except Title V air operation permit revision applications if this information was submitted to the department within the previous five years and would not be altered as a result of the revision being sought)<br><input checked="" type="checkbox"/> Attached, Document ID: <u>Attach. B</u> <input type="checkbox"/> Previously Submitted, Date _____  |
| 2. Fuel Analysis or Specification: (Required for all permit applications, except Title V air operation permit revision applications if this information was submitted to the department within the previous five years and would not be altered as a result of the revision being sought)<br><input checked="" type="checkbox"/> Attached, Document ID: <u>Attach. G</u> <input type="checkbox"/> Previously Submitted, Date _____  |
| 3. Detailed Description of Control Equipment: (Required for all permit applications, except Title V air operation permit revision applications if this information was submitted to the department within the previous five years and would not be altered as a result of the revision being sought)<br><input type="checkbox"/> Attached, Document ID: <u>NA</u> <input type="checkbox"/> Previously Submitted, Date _____   |
| 4. Procedures for Startup and Shutdown: (Required for all operation permit applications, except Title V air operation permit revision applications if this information was submitted to the department within the previous five years and would not be altered as a result of the revision being sought)<br><input type="checkbox"/> Attached, Document ID: _____ <input type="checkbox"/> Previously Submitted, Date _____<br><input checked="" type="checkbox"/> Not Applicable (construction application)  |
| 5. Operation and Maintenance Plan: (Required for all permit applications, except Title V air operation permit revision applications if this information was submitted to the department within the previous five years and would not be altered as a result of the revision being sought)<br><input type="checkbox"/> Attached, Document ID: _____ <input type="checkbox"/> Previously Submitted, Date _____<br><input checked="" type="checkbox"/> Not Applicable  |
| 6. Compliance Demonstration Reports/Records:<br><input type="checkbox"/> Attached, Document ID: _____<br>Test Date(s)/Pollutant(s) Tested: _____<br><input type="checkbox"/> Previously Submitted, Date: _____<br>Test Date(s)/Pollutant(s) Tested: _____<br><input type="checkbox"/> To be Submitted, Date (if known): _____<br>Test Date(s)/Pollutant(s) Tested: _____<br><input checked="" type="checkbox"/> Not Applicable<br>Note: For FESOP applications, all required compliance demonstration records/reports must be submitted at the time of application. For Title V air operation permit applications, all required compliance demonstration reports/records must be submitted at the time of application, or a compliance plan must be submitted at the time of application. |
| 7. Other Information Required by Rule or Statute:<br><input type="checkbox"/> Attached, Document ID: _____ <input checked="" type="checkbox"/> Not Applicable   |

**EMISSIONS UNIT INFORMATION**

Section | 2 | of | 4 |

**I. EMISSIONS UNIT ADDITIONAL INFORMATION (CONTINUED)**

**Additional Requirements for Air Construction Permit Applications**

|  |
|--|
| 1. Control Technology Review and Analysis (Rules 62-212.400(10) and 62-212.500(7), F.A.C.; 40 CFR 63.43(d) and (e)):<br><input checked="" type="checkbox"/> Attached, Document ID: <u>Narr. Sec. 3.0</u> <input type="checkbox"/> Not Applicable |
| 2. Good Engineering Practice Stack Height Analysis (Rules 62-212.400(4)(d) and 62-212.500(4)(f), F.A.C.):<br><input type="checkbox"/> Attached, Document ID: _____ <input checked="" type="checkbox"/> Not Applicable                            |
| 3. Description of Stack Sampling Facilities: (Required for proposed new stack sampling facilities only)<br><input checked="" type="checkbox"/> Attached, Document ID: <u>See Note Below</u> <input type="checkbox"/> Not Applicable              |

**Additional Requirements for Title V Air Operation Permit Applications**

|   |
|---|
| 1. Identification of Applicable Requirements:<br><input type="checkbox"/> Attached, Document ID: <u>NA</u>  |
| 2. Compliance Assurance Monitoring:<br><input type="checkbox"/> Attached, Document ID: _____ <input type="checkbox"/> Not Applicable                    |
| 3. Alternative Methods of Operation:<br><input type="checkbox"/> Attached, Document ID: _____ <input type="checkbox"/> Not Applicable                   |
| 4. Alternative Modes of Operation (Emissions Trading):<br><input type="checkbox"/> Attached, Document ID: _____ <input type="checkbox"/> Not Applicable |

**Additional Requirements Comment**

Supplemental information is provided in the narrative description accompanying these forms.

Specifications for the engine silencers/stacks have not been completed at this time. Final specifications will comply with USEPA and FDEP regulatory requirements.

**EMISSIONS UNIT INFORMATION**

Section [ 3] of [ 4]

**A. GENERAL EMISSIONS UNIT INFORMATION**

**Title V Air Operation Permit Emissions Unit Classification**

1. Regulated or Unregulated Emissions Unit? (Check one, if applying for an initial, revised or renewal Title V air operation permit. Skip this item if applying for an air construction permit or FESOP only.) NA

The emissions unit addressed in this Emissions Unit Information Section is a regulated emissions unit.

The emissions unit addressed in this Emissions Unit Information Section is an unregulated emissions unit.

**Emissions Unit Description and Status**

1. Type of Emissions Unit Addressed in this Section: (Check one)

This Emissions Unit Information Section addresses, as a single emissions unit, a single process or production unit, or activity, which produces one or more air pollutants and which has at least one definable emission point (stack or vent).

This Emissions Unit Information Section addresses, as a single emissions unit, a group of process or production units and activities which has at least one definable emission point (stack or vent) but may also produce fugitive emissions.

This Emissions Unit Information Section addresses, as a single emissions unit, one or more process or production units and activities which produce fugitive emissions only.

1. Description of Emissions Unit Addressed in this Section:

454 bhp natural gas fired, spark ignition, 4-stroke, rich-burn, internal combustion emergency generator engine, FGT Engine No. GEN01

3. Emissions Unit Identification Number: 003

|   |  |                                    |   |
|---|--|------------------------------------|---|
| 4. Emissions Unit Status Code:<br><br>C | 5. Commence Construction Date:<br><br>NA | 6. Initial Startup Date:<br><br>NA | 7. Emissions Unit Major Group SIC Code:<br><br>49 |
|---|--|------------------------------------|---|

8. Federal Program Applicability: (Check all that apply)

Acid Rain Unit

CAIR Unit

Hg Budget Unit

9. Package Unit:  
Manufacturer: Generac  
Model Number: SG300

10. Generator Nameplate Rating: 0.3 MW

11. Emissions Unit Comment:

Fuel will be exclusively natural gas from the FGT's gas pipeline.

**EMISSIONS UNIT INFORMATION**

**Section [ 3] of [ 4]**

**Emissions Unit Control Equipment/Method:** Control NA of   

|  |
|--|
| 1. Control Equipment/Method Description: |
|--|

|                                   |
|-----------------------------------|
| 2. Control Device or Method Code: |
|-----------------------------------|

**Emissions Unit Control Equipment/Method:** Control    of   

|  |
|--|
| 1. Control Equipment/Method Description: |
|--|

|                                   |
|-----------------------------------|
| 2. Control Device or Method Code: |
|-----------------------------------|

**Emissions Unit Control Equipment/Method:** Control    of   

|  |
|--|
| 1. Control Equipment/Method Description: |
|--|

|                                   |
|-----------------------------------|
| 2. Control Device or Method Code: |
|-----------------------------------|

**Emissions Unit Control Equipment/Method:** Control    of   

|  |
|--|
| 1. Control Equipment/Method Description: |
|--|

|                                   |
|-----------------------------------|
| 2. Control Device or Method Code: |
|-----------------------------------|



**EMISSIONS UNIT INFORMATION**

Section [3] of [4]

**C. EMISSION POINT (STACK/VENT) INFORMATION**

(Optional for unregulated emissions units.)

**Emission Point Description and Type**

|   |  |  |   |                                |  |
|---|--|--|---|--------------------------------|--|
| 1. Identification of Point on Plot Plan or Flow Diagram: GEN01                                |  | 2. Emission Point Type Code:<br>1            |   |                                |  |
| 3. Descriptions of Emission Points Comprising this Emissions Unit for VE Tracking:<br><br>NA  |  |  |   |                                |  |
| 4. ID Numbers or Descriptions of Emission Units with this Emission Point in Common:<br><br>NA |  |  |   |                                |  |
| 5. Discharge Type Code:<br>V  |  | 6. Stack Height:<br>7.0 Feet                 |   | 7. Exit Diameter:<br>0.33 feet |  |
| 8. Exit Temperature:<br>1490 °F   |  | 9. Actual Volumetric Flow Rate:<br>4335 acfm |   | 10. Water Vapor:<br>NA %       |  |
| 11. Maximum Dry Standard Flow Rate:<br>NA dscfm   |  |  | 12. Nonstack Emission Point Height:<br>NA feet  |                                |  |
| 13. Emission Point UTM Coordinates...<br>Zone: 17 East (km): 494.3<br>North (km): 3012.4      |  |  | 14. Emission Point Latitude/Longitude...<br>Latitude (DD/MM/SS)<br>Longitude (DD/MM/SS) |                                |  |
| 15. Emission Point Comment:   |  |  |   |                                |  |

**EMISSIONS UNIT INFORMATION**

Section | 3 | of | 4 |

**D. SEGMENT (PROCESS/FUEL) INFORMATION****Segment Description and Rate:** Segment 1 of 1

|   |                                 |  |
|---|---------------------------------|--|
| 1. Segment Description (Process/Fuel Type):<br><br>Natural gas fired 4-stroke, rich-burn engine driving an emergency generator. |                                 |  |
| 2. Source Classification Code (SCC):<br>2-02-002-53   |                                 | 3. SCC Units:<br>million cubic feet burned |
| 4. Maximum Hourly Rate:<br>0.0041   | 5. Maximum Annual Rate:<br>0.41 | 6. Estimated Annual Activity Factor: NA    |
| 7. Maximum % Sulfur:<br>NA  | 8. Maximum % Ash:<br>NA         | 9. Million Btu per SCC Unit:<br>1040       |
| 10. Segment Comment:<br><br>Annual usage based on 100 hours per year operation.   |                                 |  |

**Segment Description and Rate:** Segment    of   

|   |                         |                                      |
|---|-------------------------|--------------------------------------|
| 1. Segment Description (Process/Fuel Type):<br><br> |                         |                                      |
| 2. Source Classification Code (SCC):                |                         | 3. SCC Units:                        |
| 4. Maximum Hourly Rate:                             | 5. Maximum Annual Rate: | 6. Estimated Annual Activity Factor: |
| 7. Maximum % Sulfur:                                | 8. Maximum % Ash:       | 9. Million Btu per SCC Unit:         |
| 10. Segment Comment:                                |                         |                                      |





**EMISSIONS UNIT INFORMATION**

Section [ 3 ] of [ 4 ]

**POLLUTANT DETAIL INFORMATION**

Page [ 1 ] of [ 6 ]

**F1. EMISSIONS UNIT POLLUTANT DETAIL INFORMATION –  
POTENTIAL, FUGITIVE, AND ACTUAL EMISSIONS  
(Optional for unregulated emissions units.)**

**Complete a Subsection F1 for each pollutant identified in Subsection E if applying for an air construction permit or concurrent processing of an air construction permit and a revised or renewal Title V operation permit. Complete for each emissions-limited pollutant identified in Subsection E if applying for an air operation permit.**

**Potential, Estimated Fugitive, and Baseline & Projected Actual Emissions**

|   |  |   |  |
|---|--|---|--|
| 1. Pollutant Emitted:<br>NOX  |  | 2. Total Percent Efficiency of Control:<br>5.7  |  |
| 3. Potential Emissions:<br>2.00 lb/hour                      1.00 tons/year   |  | 4. Synthetically Limited?<br><input type="checkbox"/> Yes <input checked="" type="checkbox"/> No        |  |
| 5. Range of Estimated Fugitive Emissions (as applicable): NA<br>to tons/year  |  |   |  |
| 6. Emission Factor: 2.00 g/hp-hr at 5.7% control<br><br>Reference: Vendor data  |  | 7. Emissions Method Code:<br>5  |  |
| 8.a. Baseline Actual Emissions (if required):<br>NA tons/year   |  | 8.b. Baseline 24-month Period:<br>From:                      To:  |  |
| 9.a. Projected Actual Emissions (if required):<br>NA tons/year  |  | 9.b. Projected Monitoring Period:<br><input type="checkbox"/> 5 years <input type="checkbox"/> 10 years |  |
| 10. Calculation of Emissions:<br><br>$((2.00 \text{ g/hp-hr})(454 \text{ bhp})(1 \text{ lb}/454 \text{ g}) = 2.00 \text{ lb/hr}$ $(2.00 \text{ lb/hr})(100 \text{ hr/yr})(1 \text{ ton}/2000 \text{ lb}) = 0.10 \text{ ton/yr}$ |  |   |  |
| 11. Potential, Fugitive, and Actual Emissions Comment:<br><br>Calculations based on emergency generator usage of 100 hours per year and minimum control efficiency.   |  |   |  |

**EMISSIONS UNIT INFORMATION**

Section [ 3 ] of [ 4 ]

**POLLUTANT DETAIL INFORMATION**

Page [ 1 ] of [ 6 ]

**F2. EMISSIONS UNIT POLLUTANT DETAIL INFORMATION -  
ALLOWABLE EMISSIONS****Complete Subsection F2 if the pollutant identified in Subsection F1 is or would be subject to a numerical emissions limitation.****Allowable Emissions** Allowable Emissions  1  of  1 

|  |  |
|--|--|
| 1. Basis for Allowable Emissions Code:<br>RULE   | 2. Future Effective Date of Allowable Emissions: NA                    |
| 3. Allowable Emissions and Units:<br>2.00 g/hp-hr.   | 4. Equivalent Allowable Emissions:<br>2.00 lb/hour      0.10 tons/year |
| 5. Method of Compliance:<br>Monitor hours of operation   |  |
| 6. Allowable Emissions Comment (Description of Operating Method):<br><br>60.4230 Table 1 limits NOX emissions to 2 g/hhp-hr. |  |

**Allowable Emissions** Allowable Emissions   of  

|   |  |
|---|--|
| 1. Basis for Allowable Emissions Code:                            | 2. Future Effective Date of Allowable Emissions:             |
| 3. Allowable Emissions and Units:                                 | 4. Equivalent Allowable Emissions:<br>lb/hour      tons/year |
| 5. Method of Compliance:  |  |
| 6. Allowable Emissions Comment (Description of Operating Method): |  |

**Allowable Emissions** Allowable Emissions   of  

|   |  |
|---|--|
| 1. Basis for Allowable Emissions Code:                            | 2. Future Effective Date of Allowable Emissions:             |
| 3. Allowable Emissions and Units:                                 | 4. Equivalent Allowable Emissions:<br>lb/hour      tons/year |
| 5. Method of Compliance:  |  |
| 6. Allowable Emissions Comment (Description of Operating Method): |  |

**EMISSIONS UNIT INFORMATION**

Section | 3 | of | 4 |

**POLLUTANT DETAIL INFORMATION**

Page | 2 | of | 6 |

**F1. EMISSIONS UNIT POLLUTANT DETAIL INFORMATION –  
POTENTIAL, FUGITIVE, AND ACTUAL EMISSIONS  
(Optional for unregulated emissions units.)**

**Complete a Subsection F1 for each pollutant identified in Subsection E if applying for an air construction permit or concurrent processing of an air construction permit and a revised or renewal Title V operation permit. Complete for each emissions-limited pollutant identified in Subsection E if applying for an air operation permit.**

**Potential, Estimated Fugitive, and Baseline & Projected Actual Emissions**

|   |  |   |  |
|---|--|---|--|
| 1. Pollutant Emitted:<br>CO   |  | 2. Total Percent Efficiency of Control:<br>96.6   |  |
| 3. Potential Emissions:<br>4.0 lb/hour                      0.40 tons/year  |  | 4. Synthetically Limited?<br><input checked="" type="checkbox"/> Yes <input type="checkbox"/> No        |  |
| 5. Range of Estimated Fugitive Emissions (as applicable): NA<br>to tons/year  |  |   |  |
| 6. Emission Factor: 4.0 g/hp-hr at 96.6% control<br><br>Reference: Vendor data  |  | 7. Emissions Method Code:<br>5  |  |
| 8.a. Baseline Actual Emissions (if required):<br>NA tons/year   |  | 8.b. Baseline 24-month Period:<br>From:                      To:  |  |
| 9.a. Projected Actual Emissions (if required):<br>NA tons/year  |  | 9.b. Projected Monitoring Period:<br><input type="checkbox"/> 5 years <input type="checkbox"/> 10 years |  |
| 10. Calculation of Emissions:<br><br>$(4.00 \text{ g/hp-hr})(454 \text{ bhp})(1 \text{ lb}/454 \text{ g}) = 4.00 \text{ lb/hr}$<br>$(4.00 \text{ lb/hr})(100 \text{ hr/yr})(1 \text{ ton}/2000 \text{ lb}) = 0.40 \text{ ton/yr}$ |  |   |  |
| 11. Potential, Fugitive, and Actual Emissions Comment:<br><br>Calculations based on emergency generator usage of 100 hours per year and minimum control efficiency.   |  |   |  |

**F2. EMISSIONS UNIT POLLUTANT DETAIL INFORMATION -  
 ALLOWABLE EMISSIONS**

**Complete Subsection F2 if the pollutant identified in Subsection F1 is or would be subject to a numerical emissions limitation.**

**Allowable Emissions** Allowable Emissions  1  of  1

|   |  |
|---|--|
| 1. Basis for Allowable Emissions Code:<br>RULE  | 2. Future Effective Date of Allowable Emissions: NA                    |
| 3. Allowable Emissions and Units:<br>4.00 g/hp-hr.  | 4. Equivalent Allowable Emissions:<br>4.00 lb/hour      0.20 tons/year |
| 5. Method of Compliance:<br>Monitor hours of operation  |  |
| 6. Allowable Emissions Comment (Description of Operating Method):<br><br>60.4230 Table I limits CO emissions to 4 g/hhp-hr. |  |

**Allowable Emissions** Allowable Emissions      of    

|   |  |
|---|--|
| 1. Basis for Allowable Emissions Code:                            | 2. Future Effective Date of Allowable Emissions:             |
| 3. Allowable Emissions and Units:                                 | 4. Equivalent Allowable Emissions:<br>lb/hour      tons/year |
| 5. Method of Compliance:  |  |
| 6. Allowable Emissions Comment (Description of Operating Method): |  |

**Allowable Emissions** Allowable Emissions      of    

|   |  |
|---|--|
| 1. Basis for Allowable Emissions Code:                            | 2. Future Effective Date of Allowable Emissions:             |
| 3. Allowable Emissions and Units:                                 | 4. Equivalent Allowable Emissions:<br>lb/hour      tons/year |
| 5. Method of Compliance:  |  |
| 6. Allowable Emissions Comment (Description of Operating Method): |  |

**F1. EMISSIONS UNIT POLLUTANT DETAIL INFORMATION –  
POTENTIAL, FUGITIVE, AND ACTUAL EMISSIONS  
(Optional for unregulated emissions units.)**

Complete a Subsection F1 for each pollutant identified in Subsection E if applying for an air construction permit or concurrent processing of an air construction permit and a revised or renewal Title V operation permit. Complete for each emissions-limited pollutant identified in Subsection E if applying for an air operation permit.

**Potential, Estimated Fugitive, and Baseline & Projected Actual Emissions**

|   |  |   |  |
|---|--|---|--|
| 1. Pollutant Emitted:<br>VOC  |  | 2. Total Percent Efficiency of Control:<br>0  |  |
| 3. Potential Emissions:<br>0.29 lb/hour                      0.01 tons/year   |  | 4. Synthetically Limited?<br><input type="checkbox"/> Yes <input checked="" type="checkbox"/> No        |  |
| 5. Range of Estimated Fugitive Emissions (as applicable): NA<br>to tons/year  |  |   |  |
| 6. Emission Factor: 2.91 g/hp-hr THC<br><br>Reference: Vendor data  |  | 7. Emissions Method Code:<br>5  |  |
| 8.a. Baseline Actual Emissions (if required):<br>NA tons/year   |  | 8.b. Baseline 24-month Period:<br>From:                      To:  |  |
| 9.a. Projected Actual Emissions (if required):<br>NA tons/year  |  | 9.b. Projected Monitoring Period:<br><input type="checkbox"/> 5 years <input type="checkbox"/> 10 years |  |
| 10. Calculation of Emissions:<br><br>Assume VOC 10% of THC = 0.29 g/hp-hr<br>(0.29 g/hp-hr)(454 bhp)(1 lb/453.6 g) = 0.29 lb/hr<br>(0.29 lb/hr)(100 hr/yr)(1 ton/2000 lb) = 0.01 ton/yr |  |   |  |
| 11. Potential, Fugitive, and Actual Emissions Comment:<br><br>Calculations based on emergency generator usage of 100 hours per year.  |  |   |  |

**F2. EMISSIONS UNIT POLLUTANT DETAIL INFORMATION -  
 ALLOWABLE EMISSIONS**

**Complete Subsection F2 if the pollutant identified in Subsection F1 is or would be subject to a numerical emissions limitation.**

**Allowable Emissions** Allowable Emissions 1 of 1

|  |  |
|--|--|
| 1. Basis for Allowable Emissions Code:<br>RULE   | 2. Future Effective Date of Allowable Emissions: NA                    |
| 3. Allowable Emissions and Units:<br>0.29 g/hhp-hr.  | 4. Equivalent Allowable Emissions:<br>0.29 lb/hour      0.01 tons/year |
| 5. Method of Compliance:<br>Monitor hours of operation   |  |
| 6. Allowable Emissions Comment (Description of Operating Method):<br><br>60.4230 Table 1 limits VOC emissions to 1 g/hhp-hr. |  |

**Allowable Emissions** Allowable Emissions    of   

|   |  |
|---|--|
| 1. Basis for Allowable Emissions Code:                            | 2. Future Effective Date of Allowable Emissions:             |
| 3. Allowable Emissions and Units:                                 | 4. Equivalent Allowable Emissions:<br>lb/hour      tons/year |
| 5. Method of Compliance:  |  |
| 6. Allowable Emissions Comment (Description of Operating Method): |  |

**Allowable Emissions** Allowable Emissions    of   

|   |  |
|---|--|
| 1. Basis for Allowable Emissions Code:                            | 2. Future Effective Date of Allowable Emissions:             |
| 3. Allowable Emissions and Units:                                 | 4. Equivalent Allowable Emissions:<br>lb/hour      tons/year |
| 5. Method of Compliance:  |  |
| 6. Allowable Emissions Comment (Description of Operating Method): |  |

**EMISSIONS UNIT INFORMATION**

Section [ 3 ] of [ 4 ]

**POLLUTANT DETAIL INFORMATION**

Page [ 4 ] of [ 6 ]

**F1. EMISSIONS UNIT POLLUTANT DETAIL INFORMATION –  
POTENTIAL, FUGITIVE, AND ACTUAL EMISSIONS  
(Optional for unregulated emissions units.)**

**Complete a Subsection F1 for each pollutant identified in Subsection E if applying for an air construction permit or concurrent processing of an air construction permit and a revised or renewal Title V operation permit. Complete for each emissions-limited pollutant identified in Subsection E if applying for an air operation permit.**

**Potential, Estimated Fugitive, and Baseline & Projected Actual Emissions**

|   |  |   |                                   |
|---|--|---|-----------------------------------|
| 1. Pollutant Emitted:<br>SO2  |  | 2. Total Percent Efficiency of Control:   |                                   |
| 3. Potential Emissions:<br>0.117 lb/hour                      0.006 tons/year   |  | 4. Synthetically Limited?<br><input checked="" type="checkbox"/> Yes <input type="checkbox"/> No        |                                   |
| 5. Range of Estimated Fugitive Emissions (as applicable): NA<br>to tons/year  |  |   |                                   |
| 6. Emission Factor: 10 grains / 100 scf<br><br>Reference: FERC limit  |  |   | 7. Emissions<br>Method Code:<br>2 |
| 8.a. Baseline Actual Emissions (if required):<br>NA tons/year   |  | 8.b. Baseline 24-month Period:<br>From:                      To:  |                                   |
| 9.a. Projected Actual Emissions (if required):<br>NA tons/year  |  | 9.b. Projected Monitoring Period:<br><input type="checkbox"/> 5 years <input type="checkbox"/> 10 years |                                   |
| 10. Calculation of Emissions:<br><br>$(10 \text{ gr S}/100 \text{ scf})(4100 \text{ scf/hr})(1 \text{ lb}/7000 \text{ gr}) = 0.059 \text{ lb S/hr}$ $(0.059 \text{ lb S/hr})(2 \text{ lb SO}_2/\text{lb S}) = 0.117 \text{ lb SO}_2/\text{hr}$ $(0.117 \text{ lb SO}_2/\text{hr})(100 \text{ hr/yr})(1 \text{ ton}/2000 \text{ lb}) = 0.006 \text{ ton/yr}$ |  |   |                                   |
| 11. Potential, Fugitive, and Actual Emissions Comment:<br><br>Calculations based on emergency generator usage of 100 hours per year.  |  |   |                                   |

**EMISSIONS UNIT INFORMATION**

Section [ 3 ] of [ 4 ]

**POLLUTANT DETAIL INFORMATION**

Page [ 4 ] of [ 6 ]

**F2. EMISSIONS UNIT POLLUTANT DETAIL INFORMATION -  
ALLOWABLE EMISSIONS****Complete Subsection F2 if the pollutant identified in Subsection F1 is or would be subject to a numerical emissions limitation.****Allowable Emissions** Allowable Emissions NA of

|   |  |
|---|--|
| 1. Basis for Allowable Emissions Code:                            | 2. Future Effective Date of Allowable Emissions: NA                          |
| 3. Allowable Emissions and Units:                                 | 4. Equivalent Allowable Emissions:<br>lb/hour                      tons/year |
| 5. Method of Compliance:  |  |
| 6. Allowable Emissions Comment (Description of Operating Method): |  |

**Allowable Emissions** Allowable Emissions \_\_\_ of \_\_\_

|   |  |
|---|--|
| 1. Basis for Allowable Emissions Code:                            | 2. Future Effective Date of Allowable Emissions:                             |
| 3. Allowable Emissions and Units:                                 | 4. Equivalent Allowable Emissions:<br>lb/hour                      tons/year |
| 5. Method of Compliance:  |  |
| 6. Allowable Emissions Comment (Description of Operating Method): |  |

**Allowable Emissions** Allowable Emissions \_\_\_ of \_\_\_

|   |  |
|---|--|
| 1. Basis for Allowable Emissions Code:                            | 2. Future Effective Date of Allowable Emissions:                             |
| 3. Allowable Emissions and Units:                                 | 4. Equivalent Allowable Emissions:<br>lb/hour                      tons/year |
| 5. Method of Compliance:  |  |
| 6. Allowable Emissions Comment (Description of Operating Method): |  |



**EMISSIONS UNIT INFORMATION**

Section [ 3 ] of [ 4 ]

**POLLUTANT DETAIL INFORMATION**

Page [ 5 ] of [ 6 ]

**F1. EMISSIONS UNIT POLLUTANT DETAIL INFORMATION –  
POTENTIAL, FUGITIVE, AND ACTUAL EMISSIONS**

**(Optional for unregulated emissions units.)**

**Complete a Subsection F1 for each pollutant identified in Subsection E if applying for an air construction permit or concurrent processing of an air construction permit and a revised or renewal Title V operation permit. Complete for each emissions-limited pollutant identified in Subsection E if applying for an air operation permit.**

**Potential, Estimated Fugitive, and Baseline & Projected Actual Emissions**

|   |  |   |  |
|---|--|---|--|
| 1. Pollutant Emitted:<br>PM   |  | 2. Total Percent Efficiency of Control:   |  |
| 3. Potential Emissions:<br>0.083 lb/hour                      0.004 tons/year   |  | 4. Synthetically Limited?<br><input checked="" type="checkbox"/> Yes <input type="checkbox"/> No        |  |
| 5. Range of Estimated Fugitive Emissions (as applicable): NA<br>to tons/year  |  |   |  |
| 6. Emission Factor: 0.01941 lb/MM Btu<br><br>Reference: Table 3.2-3, AP-42 7/00   |  | 7. Emissions Method Code:<br>3  |  |
| 8.a. Baseline Actual Emissions (if required):<br>NA tons/year   |  | 8.b. Baseline 24-month Period:<br>From:                      To:  |  |
| 9.a. Projected Actual Emissions (if required):<br>NA tons/year  |  | 9.b. Projected Monitoring Period:<br><input type="checkbox"/> 5 years <input type="checkbox"/> 10 years |  |
| 10. Calculation of Emissions:<br><br>$(0.01941 \text{ lb/MM Btu})(4.26 \text{ MM Btu/hr}) = 0.083 \text{ lb/hr}$<br>$(0.083 \text{ lb/hr})(100 \text{ hr/yr})(1 \text{ ton}/2000 \text{ lb}) = 0.004 \text{ ton/y}$ |  |   |  |
| 11. Potential, Fugitive, and Actual Emissions Comment:<br><br>Calculations based on emergency generator usage of 100 hours per year.  |  |   |  |

**EMISSIONS UNIT INFORMATION**

Section [ 3 ] of [ 4 ]

**POLLUTANT DETAIL INFORMATION**

Page [ 5 ] of [ 6 ]

**F2. EMISSIONS UNIT POLLUTANT DETAIL INFORMATION -  
ALLOWABLE EMISSIONS****Complete Subsection F2 if the pollutant identified in Subsection F1 is or would be subject to a numerical emissions limitation.****Allowable Emissions** Allowable Emissions NA of

|   |  |
|---|--|
| 1. Basis for Allowable Emissions Code:                            | 2. Future Effective Date of Allowable Emissions: NA                          |
| 3. Allowable Emissions and Units:                                 | 4. Equivalent Allowable Emissions:<br>lb/hour                      tons/year |
| 5. Method of Compliance:  |  |
| 6. Allowable Emissions Comment (Description of Operating Method): |  |

**Allowable Emissions** Allowable Emissions \_\_ of \_\_

|   |  |
|---|--|
| 1. Basis for Allowable Emissions Code:                            | 2. Future Effective Date of Allowable Emissions:                             |
| 3. Allowable Emissions and Units:                                 | 4. Equivalent Allowable Emissions:<br>lb/hour                      tons/year |
| 5. Method of Compliance:  |  |
| 6. Allowable Emissions Comment (Description of Operating Method): |  |

**Allowable Emissions** Allowable Emissions \_\_ of \_\_

|   |  |
|---|--|
| 1. Basis for Allowable Emissions Code:                            | 2. Future Effective Date of Allowable Emissions:                             |
| 3. Allowable Emissions and Units:                                 | 4. Equivalent Allowable Emissions:<br>lb/hour                      tons/year |
| 5. Method of Compliance:  |  |
| 6. Allowable Emissions Comment (Description of Operating Method): |  |

**EMISSIONS UNIT INFORMATION**

Section [ 3 ] of [ 4 ]

**POLLUTANT DETAIL INFORMATION**

Page [ 6 ] of [ 6 ]

**F1. EMISSIONS UNIT POLLUTANT DETAIL INFORMATION –  
POTENTIAL, FUGITIVE, AND ACTUAL EMISSIONS  
(Optional for unregulated emissions units.)**

**Complete a Subsection F1 for each pollutant identified in Subsection E if applying for an air construction permit or concurrent processing of an air construction permit and a revised or renewal Title V operation permit. Complete for each emissions-limited pollutant identified in Subsection E if applying for an air operation permit.**

**Potential, Estimated Fugitive, and Baseline & Projected Actual Emissions**

|   |  |   |  |
|---|--|---|--|
| 1. Pollutant Emitted:<br>HAPS   |  | 2. Total Percent Efficiency of Control:   |  |
| 3. Potential Emissions:<br>0.10 lb/hour                      0.005 tons/year  |  | 4. Synthetically Limited?<br><input checked="" type="checkbox"/> Yes <input type="checkbox"/> No        |  |
| 5. Range of Estimated Fugitive Emissions (as applicable): NA<br>to tons/year  |  |   |  |
| 6. Emission Factor: 0.0234 lb/MM Btu<br><br>Reference: AP-42, Table 3.2-3   |  | 7. Emissions Method Code:<br>3  |  |
| 8.a. Baseline Actual Emissions (if required):<br>NA tons/year   |  | 8.b. Baseline 24-month Period:<br>From:                      To:  |  |
| 9.a. Projected Actual Emissions (if required):<br>NA tons/year  |  | 9.b. Projected Monitoring Period:<br><input type="checkbox"/> 5 years <input type="checkbox"/> 10 years |  |
| 10. Calculation of Emissions:<br><br>$(0.0234 \text{ lb/MM Btu})(4.26 \text{ MM Btu/hr}) = 0.10 \text{ lb/hr}$<br>$(0.10 \text{ lb/hr})(8760 \text{ hr/yr})(1 \text{ ton}/2000 \text{ lb}) = 0.005 \text{ ton/y}$ |  |   |  |
| 11. Potential, Fugitive, and Actual Emissions Comment:<br><br>Calculations based on emergency generator usage of 100 hours per year.  |  |   |  |

**F2. EMISSIONS UNIT POLLUTANT DETAIL INFORMATION -  
 ALLOWABLE EMISSIONS**

**Complete Subsection F2 if the pollutant identified in Subsection F1 is or would be subject to a numerical emissions limitation.**

**Allowable Emissions** Allowable Emissions NA of

|   |  |
|---|--|
| 1. Basis for Allowable Emissions Code:                            | 2. Future Effective Date of Allowable Emissions: NA                          |
| 3. Allowable Emissions and Units:                                 | 4. Equivalent Allowable Emissions:<br>lb/hour                      tons/year |
| 5. Method of Compliance:  |  |
| 6. Allowable Emissions Comment (Description of Operating Method): |  |

**Allowable Emissions** Allowable Emissions \_\_ of \_\_

|   |  |
|---|--|
| 1. Basis for Allowable Emissions Code:                            | 2. Future Effective Date of Allowable Emissions:                             |
| 3. Allowable Emissions and Units:                                 | 4. Equivalent Allowable Emissions:<br>lb/hour                      tons/year |
| 5. Method of Compliance:  |  |
| 6. Allowable Emissions Comment (Description of Operating Method): |  |

**Allowable Emissions** Allowable Emissions \_\_ of \_\_

|   |  |
|---|--|
| 1. Basis for Allowable Emissions Code:                            | 2. Future Effective Date of Allowable Emissions:                             |
| 3. Allowable Emissions and Units:                                 | 4. Equivalent Allowable Emissions:<br>lb/hour                      tons/year |
| 5. Method of Compliance:  |  |
| 6. Allowable Emissions Comment (Description of Operating Method): |  |



**EMISSIONS UNIT INFORMATION**

Section | 3| of | 4|

**H. CONTINUOUS MONITOR INFORMATION**

**Complete Subsection H if this emissions unit is or would be subject to continuous monitoring.**

**Continuous Monitoring System:** Continuous Monitor NA of \_\_

|  |  |
|--|--|
| 1. Parameter Code:   | 2. Pollutant(s):   |
| 3. CMS Requirement:  | <input type="checkbox"/> Rule <input type="checkbox"/> Other |
| 4. Monitor Information...<br>Manufacturer:<br>Model Number: Serial Number: |  |
| 5. Installation Date:  | 6. Performance Specification Test Date:                      |
| 7. Continuous Monitor Comment:   |  |

**Continuous Monitoring System:** Continuous Monitor \_\_ of \_\_

|  |  |
|--|--|
| 1. Parameter Code:   | 2. Pollutant(s):   |
| 3. CMS Requirement:  | <input type="checkbox"/> Rule <input type="checkbox"/> Other |
| 4. Monitor Information...<br>Manufacturer:<br>Model Number: Serial Number: |  |
| 5. Installation Date:  | 6. Performance Specification Test Date:                      |
| 7. Continuous Monitor Comment:   |  |

**EMISSIONS UNIT INFORMATION**

Section | 3 | of | 4 |

**I. EMISSIONS UNIT ADDITIONAL INFORMATION**

**Additional Requirements for All Applications, Except as Otherwise Stated**

|  |
|--|
| 1. Process Flow Diagram: (Required for all permit applications, except Title V air operation permit revision applications if this information was submitted to the department within the previous five years and would not be altered as a result of the revision being sought)<br><input checked="" type="checkbox"/> Attached, Document ID: <u>Attach. B</u> <input type="checkbox"/> Previously Submitted, Date _____   |
| 2. Fuel Analysis or Specification: (Required for all permit applications, except Title V air operation permit revision applications if this information was submitted to the department within the previous five years and would not be altered as a result of the revision being sought)<br><input checked="" type="checkbox"/> Attached, Document ID: <u>Attach. G</u> <input type="checkbox"/> Previously Submitted, Date _____   |
| 3. Detailed Description of Control Equipment: (Required for all permit applications, except Title V air operation permit revision applications if this information was submitted to the department within the previous five years and would not be altered as a result of the revision being sought)<br><input checked="" type="checkbox"/> Attached, Document ID: <u>See note below</u> <input type="checkbox"/> Previously Submitted, Date _____   |
| 4. Procedures for Startup and Shutdown: (Required for all operation permit applications, except Title V air operation permit revision applications if this information was submitted to the department within the previous five years and would not be altered as a result of the revision being sought)<br><input type="checkbox"/> Attached, Document ID: _____ <input type="checkbox"/> Previously Submitted, Date _____<br><input checked="" type="checkbox"/> Not Applicable (construction application)   |
| 5. Operation and Maintenance Plan: (Required for all permit applications, except Title V air operation permit revision applications if this information was submitted to the department within the previous five years and would not be altered as a result of the revision being sought)<br><input type="checkbox"/> Attached, Document ID: _____ <input type="checkbox"/> Previously Submitted, Date _____<br><input checked="" type="checkbox"/> Not Applicable   |
| 6. Compliance Demonstration Reports/Records:<br><input type="checkbox"/> Attached, Document ID: _____<br>Test Date(s)/Pollutant(s) Tested: _____<br>_____<br><input type="checkbox"/> Previously Submitted, Date: _____<br>Test Date(s)/Pollutant(s) Tested: _____<br>_____<br><input type="checkbox"/> To be Submitted, Date (if known): _____<br>Test Date(s)/Pollutant(s) Tested: _____<br>_____<br><input checked="" type="checkbox"/> Not Applicable<br><br>Note: For FESOP applications, all required compliance demonstration records/reports must be submitted at the time of application. For Title V air operation permit applications, all required compliance demonstration reports/records must be submitted at the time of application, or a compliance plan must be submitted at the time of application. |
| 7. Other Information Required by Rule or Statute:<br><input type="checkbox"/> Attached, Document ID: _____ <input checked="" type="checkbox"/> Not Applicable  |

**EMISSIONS UNIT INFORMATION**

Section | 3 | of | 4 |

**I. EMISSIONS UNIT ADDITIONAL INFORMATION (CONTINUED)**

**Additional Requirements for Air Construction Permit Applications**

|   |
|---|
| 1. Control Technology Review and Analysis (Rules 62-212.400(10) and 62-212.500(7), F.A.C.; 40 CFR 63.43(d) and (e):<br><input checked="" type="checkbox"/> Attached, Document ID: <i>Narr. Sec. 3.0</i> <input type="checkbox"/> Not Applicable |
| 2. Good Engineering Practice Stack Height Analysis (Rules 62-212.400(4)(d) and 62-212.500(4)(f), F.A.C.):<br><input type="checkbox"/> Attached, Document ID: _____ <input checked="" type="checkbox"/> Not Applicable                           |
| 3. Description of Stack Sampling Facilities: (Required for proposed new stack sampling facilities only)<br><input checked="" type="checkbox"/> Attached, Document ID: <i>See note below</i> <input type="checkbox"/> Not Applicable             |

**Additional Requirements for Title V Air Operation Permit Applications**

|   |
|---|
| 1. Identification of Applicable Requirements:<br><input type="checkbox"/> Attached, Document ID: NA _____   |
| 2. Compliance Assurance Monitoring:<br><input type="checkbox"/> Attached, Document ID: _____ <input type="checkbox"/> Not Applicable                    |
| 3. Alternative Methods of Operation:<br><input type="checkbox"/> Attached, Document ID: _____ <input type="checkbox"/> Not Applicable                   |
| 4. Alternative Modes of Operation (Emissions Trading):<br><input type="checkbox"/> Attached, Document ID: _____ <input type="checkbox"/> Not Applicable |

**Additional Requirements Comment**

Supplemental information is provided in the narrative description accompanying these forms.

The manufacturer has not completed design specifications and has not provided final emission rates at this time. Emissions will comply with applicable 40 CFR Subpart JJJJ requirements.

Specifications for the sampling facilities have not been completed at this time. Final specifications will comply with USEPA and FDEP regulatory requirements.



**EMISSIONS UNIT INFORMATION**

Section [ 4 ] of [ 4 ]

**A. GENERAL EMISSIONS UNIT INFORMATION**

**Title V Air Operation Permit Emissions Unit Classification**

1. Regulated or Unregulated Emissions Unit? (Check one, if applying for an initial, revised or renewal Title V air operation permit. Skip this item if applying for an air construction permit or FESOP only.) NA
- The emissions unit addressed in this Emissions Unit Information Section is a regulated emissions unit.
- The emissions unit addressed in this Emissions Unit Information Section is an unregulated emissions unit.

**Emissions Unit Description and Status**

1. Type of Emissions Unit Addressed in this Section: (Check one)
- This Emissions Unit Information Section addresses, as a single emissions unit, a single process or production unit, or activity, which produces one or more air pollutants and which has at least one definable emission point (stack or vent).
- This Emissions Unit Information Section addresses, as a single emissions unit, a group of process or production units and activities which has at least one definable emission point (stack or vent) but may also produce fugitive emissions.
- This Emissions Unit Information Section addresses, as a single emissions unit, one or more process or production units and activities which produce fugitive emissions only.

1. Description of Emissions Unit Addressed in this Section:

454 bhp natural gas fired, spark ignition, 4-stroke, rich-burn, internal combustion emergency generator engine, FGT Engine No. GEN02

3. Emissions Unit Identification Number: 004

|   |  |                                    |   |
|---|--|------------------------------------|---|
| 4. Emissions Unit Status Code:<br><br>C | 5. Commence Construction Date:<br><br>NA | 6. Initial Startup Date:<br><br>NA | 7. Emissions Unit Major Group SIC Code:<br><br>49 |
|---|--|------------------------------------|---|

8. Federal Program Applicability: (Check all that apply)

- Acid Rain Unit
- CAIR Unit
- Hg Budget Unit

9. Package Unit:

Manufacturer: Generac

Model Number: SG300

10. Generator Nameplate Rating: 0.3 MW

11. Emissions Unit Comment:

Fuel will be exclusively natural gas from the FGT's gas pipeline.

**EMISSIONS UNIT INFORMATION**

Section [ 4 ] of [ 4 ]

**Emissions Unit Control Equipment/Method:** Control NA of \_\_

1. Control Equipment/Method Description:

2. Control Device or Method Code:

**Emissions Unit Control Equipment/Method:** Control \_\_ of \_\_

1. Control Equipment/Method Description:

2. Control Device or Method Code:

**Emissions Unit Control Equipment/Method:** Control \_\_ of \_\_

1. Control Equipment/Method Description:

2. Control Device or Method Code:

**Emissions Unit Control Equipment/Method:** Control \_\_ of \_\_

1. Control Equipment/Method Description:

2. Control Device or Method Code:

**EMISSIONS UNIT INFORMATION**

Section [ 4 ] of [ 4 ]

**B. EMISSIONS UNIT CAPACITY INFORMATION**

(Optional for unregulated emissions units.)

**Emissions Unit Operating Capacity and Schedule**

|   |
|---|
| 1. Maximum Process or Throughput Rate: NA   |
| 2. Maximum Production Rate: NA  |
| 3. Maximum Heat Input Rate: 4.26 million Btu/hr   |
| 4. Maximum Incineration Rate: pounds/hr NA<br>tons/day  |
| 5. Requested Maximum Operating Schedule:<br>hours/day days/week<br>weeks/year 100 hours/year  |
| 6. Operating Capacity/Schedule Comment:<br><br>Schedule is based on USEPA defined emergency generator usage of 100 hours per year for maintenance and testing (40 CFR 60.4243(d)). This does not include emergency operation. |

**EMISSIONS UNIT INFORMATION**

Section [ 4] of [ 4]

**C. EMISSION POINT (STACK/VENT) INFORMATION**

(Optional for unregulated emissions units.)

**Emission Point Description and Type**

|   |  |   |                                |
|---|--|---|--------------------------------|
| 1. Identification of Point on Plot Plan or Flow Diagram: GEN02                                |  | 2. Emission Point Type Code:<br>1   |                                |
| 3. Descriptions of Emission Points Comprising this Emissions Unit for VE Tracking:<br><br>NA  |  |   |                                |
| 4. ID Numbers or Descriptions of Emission Units with this Emission Point in Common:<br><br>NA |  |   |                                |
| 5. Discharge Type Code:<br>V  | 6. Stack Height:<br>7.0 Feet                 |   | 7. Exit Diameter:<br>0.33 feet |
| 8. Exit Temperature:<br>1490 °F   | 9. Actual Volumetric Flow Rate:<br>4335 acfm | 10. Water Vapor:<br>NA %  |                                |
| 11. Maximum Dry Standard Flow Rate:<br>NA dscfm   |  | 12. Nonstack Emission Point Height:<br>NA feet  |                                |
| 13. Emission Point UTM Coordinates...<br>Zone: 17 East (km): 494.3<br>North (km): 3012.4      |  | 14. Emission Point Latitude/Longitude...<br>Latitude (DD/MM/SS)<br>Longitude (DD/MM/SS) |                                |
| 15. Emission Point Comment:   |  |   |                                |

**EMISSIONS UNIT INFORMATION**

Section [ 4 ] of [ 4 ]

**D. SEGMENT (PROCESS/FUEL) INFORMATION**

**Segment Description and Rate:** Segment  1  of  1

|   |                                 |  |
|---|---------------------------------|--|
| 1. Segment Description (Process/Fuel Type):<br><br>Natural gas fired 4-stroke, rich-burn engine driving an emergency generator. |                                 |  |
| 2. Source Classification Code (SCC):<br>2-02-002-53   |                                 | 3. SCC Units:<br>million cubic feet burned |
| 4. Maximum Hourly Rate:<br>0.0041   | 5. Maximum Annual Rate:<br>0.41 | 6. Estimated Annual Activity Factor:<br>NA |
| 7. Maximum % Sulfur:<br>NA  | 8. Maximum % Ash:<br>NA         | 9. Million Btu per SCC Unit:<br>1040       |
| 10. Segment Comment:<br><br>Annual usage based on 100 hours per year operation.   |                                 |  |

**Segment Description and Rate:** Segment   of

|   |                         |                                      |
|---|-------------------------|--------------------------------------|
| 1. Segment Description (Process/Fuel Type):<br><br> |                         |                                      |
| 2. Source Classification Code (SCC):                |                         | 3. SCC Units:                        |
| 4. Maximum Hourly Rate:                             | 5. Maximum Annual Rate: | 6. Estimated Annual Activity Factor: |
| 7. Maximum % Sulfur:                                | 8. Maximum % Ash:       | 9. Million Btu per SCC Unit:         |
| 10. Segment Comment:<br><br>                        |                         |                                      |



**EMISSIONS UNIT INFORMATION**

Section [ 4 ] of [ 4 ]

**POLLUTANT DETAIL INFORMATION**

Page [ 1 ] of [ 6 ]

**F1. EMISSIONS UNIT POLLUTANT DETAIL INFORMATION –  
POTENTIAL, FUGITIVE, AND ACTUAL EMISSIONS  
(Optional for unregulated emissions units.)**

**Complete a Subsection F1 for each pollutant identified in Subsection E if applying for an air construction permit or concurrent processing of an air construction permit and a revised or renewal Title V operation permit. Complete for each emissions-limited pollutant identified in Subsection E if applying for an air operation permit.**

**Potential, Estimated Fugitive, and Baseline & Projected Actual Emissions**

|  |  |   |  |
|--|--|---|--|
| 1. Pollutant Emitted:<br>NOX   |  | 2. Total Percent Efficiency of Control:<br>5.7  |  |
| 3. Potential Emissions:<br>2.00 lb/hour                      0.20 tons/year  |  | 4. Synthetically Limited?<br><input type="checkbox"/> Yes <input checked="" type="checkbox"/> No        |  |
| 5. Range of Estimated Fugitive Emissions (as applicable): NA<br>to tons/year   |  |   |  |
| 6. Emission Factor: 2.00 g/hp-hr at 5.7% control<br><br>Reference: Vendor data   |  | 7. Emissions Method Code:<br>5  |  |
| 8.a. Baseline Actual Emissions (if required):<br>NA tons/year  |  | 8.b. Baseline 24-month Period:<br>From:                      To:  |  |
| 9.a. Projected Actual Emissions (if required):<br>NA tons/year   |  | 9.b. Projected Monitoring Period:<br><input type="checkbox"/> 5 years <input type="checkbox"/> 10 years |  |
| 10. Calculation of Emissions:<br><br>$(2.00 \text{ g/hp-hr})(454 \text{ bhp})(1 \text{ lb}/454 \text{ g}) = 2.00 \text{ lb/hr}$ $(2.00 \text{ lb/hr})(100 \text{ hr/yr})(1 \text{ ton}/2000 \text{ lb}) = 0.10 \text{ ton/yr}$ |  |   |  |
| 11. Potential, Fugitive, and Actual Emissions Comment:<br><br>Calculations based on emergency generator usage of 100 hours per year and minimum control efficiency.  |  |   |  |

**EMISSIONS UNIT INFORMATION**

Section [ 4 ] of [ 4 ]

**POLLUTANT DETAIL INFORMATION**

Page [ 1 ] of [ 6 ]

**F2. EMISSIONS UNIT POLLUTANT DETAIL INFORMATION -  
ALLOWABLE EMISSIONS****Complete Subsection F2 if the pollutant identified in Subsection F1 is or would be subject to a numerical emissions limitation.****Allowable Emissions** Allowable Emissions 1 of 1

|  |  |
|--|--|
| 1. Basis for Allowable Emissions Code:<br>RULE   | 2. Future Effective Date of Allowable Emissions: NA                    |
| 3. Allowable Emissions and Units:<br>2.0 g/hp-hr.  | 4. Equivalent Allowable Emissions:<br>2.00 lb/hour      0.10 tons/year |
| 5. Method of Compliance:<br>Monitor hours of operation   |  |
| 6. Allowable Emissions Comment (Description of Operating Method):<br><br>60.4230 Table I limits NOX emissions to 2 g/hhp-hr. |  |

**Allowable Emissions** Allowable Emissions    of   

|   |  |
|---|--|
| 1. Basis for Allowable Emissions Code:                            | 2. Future Effective Date of Allowable Emissions:             |
| 3. Allowable Emissions and Units:                                 | 4. Equivalent Allowable Emissions:<br>lb/hour      tons/year |
| 5. Method of Compliance:  |  |
| 6. Allowable Emissions Comment (Description of Operating Method): |  |

**Allowable Emissions** Allowable Emissions    of   

|   |  |
|---|--|
| 1. Basis for Allowable Emissions Code:                            | 2. Future Effective Date of Allowable Emissions:             |
| 3. Allowable Emissions and Units:                                 | 4. Equivalent Allowable Emissions:<br>lb/hour      tons/year |
| 5. Method of Compliance:  |  |
| 6. Allowable Emissions Comment (Description of Operating Method): |  |



**F1. EMISSIONS UNIT POLLUTANT DETAIL INFORMATION –  
POTENTIAL, FUGITIVE, AND ACTUAL EMISSIONS  
(Optional for unregulated emissions units.)**

**Complete a Subsection F1 for each pollutant identified in Subsection E if applying for an air construction permit or concurrent processing of an air construction permit and a revised or renewal Title V operation permit. Complete for each emissions-limited pollutant identified in Subsection E if applying for an air operation permit.**

**Potential, Estimated Fugitive, and Baseline & Projected Actual Emissions**

|   |  |   |  |
|---|--|---|--|
| 1. Pollutant Emitted:<br>CO   |  | 2. Total Percent Efficiency of Control:<br>96.6   |  |
| 3. Potential Emissions:<br>4.00 lb/hour                      0.20 tons/year   |  | 4. Synthetically Limited?<br><input checked="" type="checkbox"/> Yes <input type="checkbox"/> No        |  |
| 5. Range of Estimated Fugitive Emissions (as applicable): NA<br>to tons/year  |  |   |  |
| 6. Emission Factor: 4.0 g/hp-hr at 96.6% control<br><br>Reference: Vendor data  |  | 7. Emissions Method Code:<br>5  |  |
| 8.a. Baseline Actual Emissions (if required):<br>NA tons/year   |  | 8.b. Baseline 24-month Period:<br>From:                      To:  |  |
| 9.a. Projected Actual Emissions (if required):<br>NA tons/year  |  | 9.b. Projected Monitoring Period:<br><input type="checkbox"/> 5 years <input type="checkbox"/> 10 years |  |
| 10. Calculation of Emissions:<br><br>4.00 g/hp-hr)(454 bhp)(1lb/454 g) = 4.00 lb/hr<br>(4.00 lb/hr)(100 hr/yr)(1 ton/2000 lb) = 0.40 ton/yr                         |  |   |  |
| 11. Potential, Fugitive, and Actual Emissions Comment:<br><br>Calculations based on emergency generator usage of 100 hours per year and minimum control efficiency. |  |   |  |

**EMISSIONS UNIT INFORMATION**

Section | 4 | of | 4 |

**POLLUTANT DETAIL INFORMATION**

Page | 2 | of | 6 |

**F2. EMISSIONS UNIT POLLUTANT DETAIL INFORMATION -  
ALLOWABLE EMISSIONS****Complete Subsection F2 if the pollutant identified in Subsection F1 is or would be subject to a numerical emissions limitation.****Allowable Emissions** Allowable Emissions 1 of 1

|   |  |
|---|--|
| 1. Basis for Allowable Emissions Code:<br>RULE  | 2. Future Effective Date of Allowable Emissions: NA                    |
| 3. Allowable Emissions and Units:<br>4.00 g/hp-hr.  | 4. Equivalent Allowable Emissions:<br>4.00 lb/hour      0.20 tons/year |
| 5. Method of Compliance:<br>Monitor hours of operation  |  |
| 6. Allowable Emissions Comment (Description of Operating Method):<br><br>60.4230 Table 1 limits CO emissions to 4 g/hhp-hr. |  |

**Allowable Emissions** Allowable Emissions    of   

|   |  |
|---|--|
| 1. Basis for Allowable Emissions Code:                            | 2. Future Effective Date of Allowable Emissions:             |
| 3. Allowable Emissions and Units:                                 | 4. Equivalent Allowable Emissions:<br>lb/hour      tons/year |
| 5. Method of Compliance:  |  |
| 6. Allowable Emissions Comment (Description of Operating Method): |  |

**Allowable Emissions** Allowable Emissions    of   

|   |  |
|---|--|
| 1. Basis for Allowable Emissions Code:                            | 2. Future Effective Date of Allowable Emissions:             |
| 3. Allowable Emissions and Units:                                 | 4. Equivalent Allowable Emissions:<br>lb/hour      tons/year |
| 5. Method of Compliance:  |  |
| 6. Allowable Emissions Comment (Description of Operating Method): |  |



**F2. EMISSIONS UNIT POLLUTANT DETAIL INFORMATION -  
 ALLOWABLE EMISSIONS**

**Complete Subsection F2 if the pollutant identified in Subsection F1 is or would be subject to a numerical emissions limitation.**

**Allowable Emissions** Allowable Emissions 1 of 1

|  |  |
|--|--|
| 1. Basis for Allowable Emissions Code:<br>RULE   | 2. Future Effective Date of Allowable Emissions: NA                    |
| 3. Allowable Emissions and Units:<br>0.29 g/hhp-hr.  | 4. Equivalent Allowable Emissions:<br>0.29 lb/hour      0.01 tons/year |
| 5. Method of Compliance:<br>Monitor hours of operation   |  |
| 6. Allowable Emissions Comment (Description of Operating Method):<br><br>60.4230 Table 1 limits VOC emissions to 1 g/hhp-hr. |  |

**Allowable Emissions** Allowable Emissions    of   

|   |  |
|---|--|
| 1. Basis for Allowable Emissions Code:                            | 2. Future Effective Date of Allowable Emissions:             |
| 3. Allowable Emissions and Units:                                 | 4. Equivalent Allowable Emissions:<br>lb/hour      tons/year |
| 5. Method of Compliance:  |  |
| 6. Allowable Emissions Comment (Description of Operating Method): |  |

**Allowable Emissions** Allowable Emissions    of   

|   |  |
|---|--|
| 1. Basis for Allowable Emissions Code:                            | 2. Future Effective Date of Allowable Emissions:             |
| 3. Allowable Emissions and Units:                                 | 4. Equivalent Allowable Emissions:<br>lb/hour      tons/year |
| 5. Method of Compliance:  |  |
| 6. Allowable Emissions Comment (Description of Operating Method): |  |

**EMISSIONS UNIT INFORMATION**

Section [ 4 ] of [ 4 ]

**POLLUTANT DETAIL INFORMATION**

Page [ 4 ] of [ 6 ]

**F1. EMISSIONS UNIT POLLUTANT DETAIL INFORMATION –  
POTENTIAL, FUGITIVE, AND ACTUAL EMISSIONS  
(Optional for unregulated emissions units.)**

**Complete a Subsection F1 for each pollutant identified in Subsection E if applying for an air construction permit or concurrent processing of an air construction permit and a revised or renewal Title V operation permit. Complete for each emissions-limited pollutant identified in Subsection E if applying for an air operation permit.**

**Potential, Estimated Fugitive, and Baseline & Projected Actual Emissions**

|   |  |   |  |
|---|--|---|--|
| 1. Pollutant Emitted:<br>SO2  |  | 2. Total Percent Efficiency of Control:   |  |
| 3. Potential Emissions:<br>0.117 lb/hour                      0.006 tons/year   |  | 4. Synthetically Limited?<br><input checked="" type="checkbox"/> Yes <input type="checkbox"/> No        |  |
| 5. Range of Estimated Fugitive Emissions (as applicable): NA<br>to tons/year  |  |   |  |
| 6. Emission Factor: 10 grains / 100 scf<br><br>Reference: FERC limit  |  | 7. Emissions Method Code:<br>2  |  |
| 8.a. Baseline Actual Emissions (if required):<br>NA tons/year   |  | 8.b. Baseline 24-month Period:<br>From:                      To:  |  |
| 9.a. Projected Actual Emissions (if required):<br>NA tons/year  |  | 9.b. Projected Monitoring Period:<br><input type="checkbox"/> 5 years <input type="checkbox"/> 10 years |  |
| 10. Calculation of Emissions:<br><br>$(10 \text{ gr S}/100 \text{ scf})(4100 \text{ scf/hr})(1 \text{ lb}/7000 \text{ gr}) = 0.059 \text{ lb S/hr}$<br>$(0.059 \text{ lb S/hr})(2 \text{ lb SO}_2/\text{lb S}) = 0.117 \text{ lb SO}_2/\text{hr}$<br>$(0.117 \text{ lb SO}_2/\text{hr})(100 \text{ hr/yr})(1 \text{ ton}/2000 \text{ lb}) = 0.006 \text{ ton/yr}$ |  |   |  |
| 11. Potential, Fugitive, and Actual Emissions Comment:<br><br>Calculations based on emergency generator usage of 100 hours per year.  |  |   |  |

**EMISSIONS UNIT INFORMATION**

Section [ 4 ] of [ 4 ]

**POLLUTANT DETAIL INFORMATION**

Page [ 4 ] of [ 6 ]

**F2. EMISSIONS UNIT POLLUTANT DETAIL INFORMATION -  
ALLOWABLE EMISSIONS****Complete Subsection F2 if the pollutant identified in Subsection F1 is or would be subject to a numerical emissions limitation.****Allowable Emissions** Allowable Emissions NA of

|   |  |
|---|--|
| 1. Basis for Allowable Emissions Code:                            | 2. Future Effective Date of Allowable Emissions: NA                          |
| 3. Allowable Emissions and Units:                                 | 4. Equivalent Allowable Emissions:<br>lb/hour                      tons/year |
| 5. Method of Compliance:  |  |
| 6. Allowable Emissions Comment (Description of Operating Method): |  |

**Allowable Emissions** Allowable Emissions \_\_ of \_\_

|   |  |
|---|--|
| 1. Basis for Allowable Emissions Code:                            | 2. Future Effective Date of Allowable Emissions:                             |
| 3. Allowable Emissions and Units:                                 | 4. Equivalent Allowable Emissions:<br>lb/hour                      tons/year |
| 5. Method of Compliance:  |  |
| 6. Allowable Emissions Comment (Description of Operating Method): |  |

**Allowable Emissions** Allowable Emissions \_\_ of \_\_

|   |  |
|---|--|
| 1. Basis for Allowable Emissions Code:                            | 2. Future Effective Date of Allowable Emissions:                             |
| 3. Allowable Emissions and Units:                                 | 4. Equivalent Allowable Emissions:<br>lb/hour                      tons/year |
| 5. Method of Compliance:  |  |
| 6. Allowable Emissions Comment (Description of Operating Method): |  |

**EMISSIONS UNIT INFORMATION**

Section | 4 | of | 4 |

**POLLUTANT DETAIL INFORMATION**

Page | 5 | of | 6 |

**F1. EMISSIONS UNIT POLLUTANT DETAIL INFORMATION –  
POTENTIAL, FUGITIVE, AND ACTUAL EMISSIONS**

(Optional for unregulated emissions units.)

Complete a Subsection F1 for each pollutant identified in Subsection E if applying for an air construction permit or concurrent processing of an air construction permit and a revised or renewal Title V operation permit. Complete for each emissions-limited pollutant identified in Subsection E if applying for an air operation permit.

**Potential, Estimated Fugitive, and Baseline & Projected Actual Emissions**

|   |  |   |  |
|---|--|---|--|
| 1. Pollutant Emitted:<br>PM   |  | 2. Total Percent Efficiency of Control:   |  |
| 3. Potential Emissions:<br>0.083 lb/hour                      0.004 tons/year   |  | 4. Synthetically Limited?<br><input checked="" type="checkbox"/> Yes <input type="checkbox"/> No        |  |
| 5. Range of Estimated Fugitive Emissions (as applicable): NA<br>to tons/year  |  |   |  |
| 6. Emission Factor: 0.01941 lb/MM Btu<br><br>Reference: Table 3.2-3, AP-42 7/00   |  | 7. Emissions Method Code:<br>3  |  |
| 8.a. Baseline Actual Emissions (if required):<br>NA tons/year   |  | 8.b. Baseline 24-month Period:<br>From:                      To:  |  |
| 9.a. Projected Actual Emissions (if required):<br>NA tons/year  |  | 9.b. Projected Monitoring Period:<br><input type="checkbox"/> 5 years <input type="checkbox"/> 10 years |  |
| 10. Calculation of Emissions:<br><br>$(0.01941 \text{ lb/MM Btu})(4.26 \text{ MM Btu/hr}) = 0.083 \text{ lb/hr}$<br>$(0.083 \text{ lb/hr})(100 \text{ hr/yr})(1 \text{ ton}/2000 \text{ lb}) = 0.004 \text{ ton/y}$ |  |   |  |
| 11. Potential, Fugitive, and Actual Emissions Comment:<br><br>Calculations based on emergency generator usage of 100 hours per year.  |  |   |  |

**EMISSIONS UNIT INFORMATION**

Section | 4 | of | 4 |

**POLLUTANT DETAIL INFORMATION**

Page | 5 | of | 6 |

**F2. EMISSIONS UNIT POLLUTANT DETAIL INFORMATION -  
ALLOWABLE EMISSIONS****Complete Subsection F2 if the pollutant identified in Subsection F1 is or would be subject to a numerical emissions limitation.****Allowable Emissions** Allowable Emissions NA of

|   |  |
|---|--|
| 1. Basis for Allowable Emissions Code:                            | 2. Future Effective Date of Allowable Emissions: NA                          |
| 3. Allowable Emissions and Units:                                 | 4. Equivalent Allowable Emissions:<br>lb/hour                      tons/year |
| 5. Method of Compliance:  |  |
| 6. Allowable Emissions Comment (Description of Operating Method): |  |

**Allowable Emissions** Allowable Emissions \_\_ of \_\_

|   |  |
|---|--|
| 1. Basis for Allowable Emissions Code:                            | 2. Future Effective Date of Allowable Emissions:                             |
| 3. Allowable Emissions and Units:                                 | 4. Equivalent Allowable Emissions:<br>lb/hour                      tons/year |
| 5. Method of Compliance:  |  |
| 6. Allowable Emissions Comment (Description of Operating Method): |  |

**Allowable Emissions** Allowable Emissions \_\_ of \_\_

|   |  |
|---|--|
| 1. Basis for Allowable Emissions Code:                            | 2. Future Effective Date of Allowable Emissions:                             |
| 3. Allowable Emissions and Units:                                 | 4. Equivalent Allowable Emissions:<br>lb/hour                      tons/year |
| 5. Method of Compliance:  |  |
| 6. Allowable Emissions Comment (Description of Operating Method): |  |



**F1. EMISSIONS UNIT POLLUTANT DETAIL INFORMATION –  
POTENTIAL, FUGITIVE, AND ACTUAL EMISSIONS  
(Optional for unregulated emissions units.)**

Complete a Subsection F1 for each pollutant identified in Subsection E if applying for an air construction permit or concurrent processing of an air construction permit and a revised or renewal Title V operation permit. Complete for each emissions-limited pollutant identified in Subsection E if applying for an air operation permit.

**Potential, Estimated Fugitive, and Baseline & Projected Actual Emissions**

|   |  |   |  |
|---|--|---|--|
| 1. Pollutant Emitted:<br>HAPS   |  | 2. Total Percent Efficiency of Control:   |  |
| 3. Potential Emissions:<br>0.10 lb/hour                      0.005 tons/year  |  | 4. Synthetically Limited?<br><input checked="" type="checkbox"/> Yes <input type="checkbox"/> No        |  |
| 5. Range of Estimated Fugitive Emissions (as applicable): NA<br>to tons/year  |  |   |  |
| 6. Emission Factor: 0.0234 lb/MM Btu<br><br>Reference: AP-42, Table 3.2-3   |  | 7. Emissions<br>Method Code:<br>3   |  |
| 8.a. Baseline Actual Emissions (if required):<br>NA tons/year   |  | 8.b. Baseline 24-month Period:<br>From:                      To:  |  |
| 9.a. Projected Actual Emissions (if required):<br>NA tons/year  |  | 9.b. Projected Monitoring Period:<br><input type="checkbox"/> 5 years <input type="checkbox"/> 10 years |  |
| 10. Calculation of Emissions:<br><br>$(0.0234 \text{ lb/MM Btu})(4.26 \text{ MM Btu/hr}) = 0.10 \text{ lb/hr}$<br>$(0.10 \text{ lb/hr})(8760 \text{ hr/yr})(1 \text{ ton}/2000 \text{ lb}) = 0.005 \text{ ton/y}$ |  |   |  |
| 11. Potential, Fugitive, and Actual Emissions Comment:<br><br>Calculations based on emergency generator usage of 100 hours per year.  |  |   |  |

**EMISSIONS UNIT INFORMATION**

Section [ 4 ] of [ 4 ]

**POLLUTANT DETAIL INFORMATION**

Page [ 6 ] of [ 6 ]

**F2. EMISSIONS UNIT POLLUTANT DETAIL INFORMATION -  
ALLOWABLE EMISSIONS****Complete Subsection F2 if the pollutant identified in Subsection F1 is or would be subject to a numerical emissions limitation.****Allowable Emissions** Allowable Emissions NA of

|   |  |
|---|--|
| 1. Basis for Allowable Emissions Code:                            | 2. Future Effective Date of Allowable Emissions: NA                          |
| 3. Allowable Emissions and Units:                                 | 4. Equivalent Allowable Emissions:<br>lb/hour                      tons/year |
| 5. Method of Compliance:  |  |
| 6. Allowable Emissions Comment (Description of Operating Method): |  |

**Allowable Emissions** Allowable Emissions    of   

|   |  |
|---|--|
| 1. Basis for Allowable Emissions Code:                            | 2. Future Effective Date of Allowable Emissions:                             |
| 3. Allowable Emissions and Units:                                 | 4. Equivalent Allowable Emissions:<br>lb/hour                      tons/year |
| 5. Method of Compliance:  |  |
| 6. Allowable Emissions Comment (Description of Operating Method): |  |

**Allowable Emissions** Allowable Emissions    of   

|   |  |
|---|--|
| 1. Basis for Allowable Emissions Code:                            | 2. Future Effective Date of Allowable Emissions:                             |
| 3. Allowable Emissions and Units:                                 | 4. Equivalent Allowable Emissions:<br>lb/hour                      tons/year |
| 5. Method of Compliance:  |  |
| 6. Allowable Emissions Comment (Description of Operating Method): |  |

BEST AVAILABLE COPY

EMISSIONS UNIT INFORMATION

Section [ 4 ] of [ 4 ]

G. VISIBLE EMISSIONS INFORMATION

Complete Subsection G if this emissions unit is or would be subject to a unit-specific visible emissions limitation.

**Visible Emissions Limitation:** Visible Emissions Limitation NA of

|   |   |
|---|---|
| 1. Visible Emissions Subtype:   | 2. Basis for Allowable Opacity:<br><input type="checkbox"/> Rule <input type="checkbox"/> Other |
| 3. Allowable Opacity:<br>Normal Conditions:                      %      Exceptional Conditions:                      %<br>Maximum Period of Excess Opacity Allowed:                      min/hour |   |
| 2. Method of Compliance:  |   |
| 3. Visible Emissions Comment:   |   |

**Visible Emissions Limitation:** Visible Emissions Limitation    of   

|   |   |
|---|---|
| 1. Visible Emissions Subtype:   | 2. Basis for Allowable Opacity:<br><input type="checkbox"/> Rule <input type="checkbox"/> Other |
| 3. Allowable Opacity:<br>Normal Conditions:                      %      Exceptional Conditions:                      %<br>Maximum Period of Excess Opacity Allowed:                      min/hour |   |
| 4. Method of Compliance:  |   |
| 5. Visible Emissions Comment:   |   |

**BEST AVAILABLE COPY**

**EMISSIONS UNIT INFORMATION**

Section [ 4 ] of [ 4 ]

**H. CONTINUOUS MONITOR INFORMATION**

**Complete Subsection H if this emissions unit is or would be subject to continuous monitoring.**

**Continuous Monitoring System:** Continuous Monitor NA of   

|   |   |
|---|---|
| 1. Parameter Code:  | 2. Pollutant(s):                        |
| 3. CMS Requirement: <input type="checkbox"/> Rule <input type="checkbox"/> Other                              |   |
| 4. Monitor Information...<br>Manufacturer:<br>Model Number: <span style="float: right;">Serial Number:</span> |   |
| 5. Installation Date:   | 6. Performance Specification Test Date: |
| 7. Continuous Monitor Comment:  |   |

**Continuous Monitoring System:** Continuous Monitor    of   

|   |   |
|---|---|
| 1. Parameter Code:  | 2. Pollutant(s):                        |
| 3. CMS Requirement: <input type="checkbox"/> Rule <input type="checkbox"/> Other                              |   |
| 4. Monitor Information...<br>Manufacturer:<br>Model Number: <span style="float: right;">Serial Number:</span> |   |
| 5. Installation Date:   | 6. Performance Specification Test Date: |
| 7. Continuous Monitor Comment:  |   |

BEST AVAILABLE COPY

EMISSIONS UNIT INFORMATION

Section [ 4 ] of [ 4 ]

I. EMISSIONS UNIT ADDITIONAL INFORMATION

Additional Requirements for All Applications, Except as Otherwise Stated

|  |
|--|
| 1. Process Flow Diagram: (Required for all permit applications, except Title V air operation permit revision applications if this information was submitted to the department within the previous five years and would not be altered as a result of the revision being sought)<br><input checked="" type="checkbox"/> Attached, Document ID: <u>Attach. B</u> <input type="checkbox"/> Previously Submitted, Date _____   |
| 2. Fuel Analysis or Specification: (Required for all permit applications, except Title V air operation permit revision applications if this information was submitted to the department within the previous five years and would not be altered as a result of the revision being sought)<br><input checked="" type="checkbox"/> Attached, Document ID: <u>Attach. G</u> <input type="checkbox"/> Previously Submitted, Date _____   |
| 3. Detailed Description of Control Equipment: (Required for all permit applications, except Title V air operation permit revision applications if this information was submitted to the department within the previous five years and would not be altered as a result of the revision being sought)<br><input checked="" type="checkbox"/> Attached, Document ID: <u>See note below</u> <input type="checkbox"/> Previously Submitted, Date _____   |
| 4. Procedures for Startup and Shutdown: (Required for all operation permit applications, except Title V air operation permit revision applications if this information was submitted to the department within the previous five years and would not be altered as a result of the revision being sought)<br><input type="checkbox"/> Attached, Document ID: _____ <input type="checkbox"/> Previously Submitted, Date _____<br><input checked="" type="checkbox"/> Not Applicable (construction application)   |
| 5. Operation and Maintenance Plan: (Required for all permit applications, except Title V air operation permit revision applications if this information was submitted to the department within the previous five years and would not be altered as a result of the revision being sought)<br><input type="checkbox"/> Attached, Document ID: _____ <input type="checkbox"/> Previously Submitted, Date _____<br><input checked="" type="checkbox"/> Not Applicable   |
| 6. Compliance Demonstration Reports/Records:<br><input type="checkbox"/> Attached, Document ID: _____<br>Test Date(s)/Pollutant(s) Tested: _____<br>_____<br><input type="checkbox"/> Previously Submitted, Date: _____<br>Test Date(s)/Pollutant(s) Tested: _____<br>_____<br><input type="checkbox"/> To be Submitted, Date (if known): _____<br>Test Date(s)/Pollutant(s) Tested: _____<br>_____<br><input checked="" type="checkbox"/> Not Applicable<br>Note: For FESOP applications, all required compliance demonstration records/reports must be submitted at the time of application. For Title V air operation permit applications, all required compliance demonstration reports/records must be submitted at the time of application, or a compliance plan must be submitted at the time of application. |
| 7. Other Information Required by Rule or Statute:<br><input type="checkbox"/> Attached, Document ID: _____ <input checked="" type="checkbox"/> Not Applicable  |

**BEST AVAILABLE COPY**

**EMISSIONS UNIT INFORMATION**

Section [ 4 ] of [ 4 ]

**I. EMISSIONS UNIT ADDITIONAL INFORMATION (CONTINUED)**

**Additional Requirements for Air Construction Permit Applications**

|  |
|--|
| 1. Control Technology Review and Analysis (Rules 62-212.400(10) and 62-212.500(7), F.A.C.; 40 CFR 63.43(d) and (e)):<br><input checked="" type="checkbox"/> Attached, Document ID: <u>Narr. Sec. 3.0</u> <input type="checkbox"/> Not Applicable |
| 2. Good Engineering Practice Stack Height Analysis (Rules 62-212.400(4)(d) and 62-212.500(4)(f), F.A.C.):<br><input type="checkbox"/> Attached, Document ID: _____ <input checked="" type="checkbox"/> Not Applicable                            |
| 3. Description of Stack Sampling Facilities: (Required for proposed new stack sampling facilities only)<br><input checked="" type="checkbox"/> Attached, Document ID: <u>See note below</u> <input type="checkbox"/> Not Applicable              |

**Additional Requirements for Title V Air Operation Permit Applications**

|   |
|---|
| 1. Identification of Applicable Requirements:<br><input type="checkbox"/> Attached, Document ID: <u>NA</u>  |
| 2. Compliance Assurance Monitoring:<br><input type="checkbox"/> Attached, Document ID: _____ <input type="checkbox"/> Not Applicable                    |
| 3. Alternative Methods of Operation:<br><input type="checkbox"/> Attached, Document ID: _____ <input type="checkbox"/> Not Applicable                   |
| 4. Alternative Modes of Operation (Emissions Trading):<br><input type="checkbox"/> Attached, Document ID: _____ <input type="checkbox"/> Not Applicable |

**Additional Requirements Comment**

Supplemental information is provided in the narrative description accompanying these forms.

The manufacturer has not completed design specifications and has not provided final emission rates at this time. Emissions will comply with applicable 40 CFR Subpart JJJ requirements.

Specifications for the sampling facilities have not been completed at this time. Final specifications will comply with USEPA and FDEP regulatory requirements.

**Attachment B**  
**Process Flow Diagram**

BEST AVAILABLE COPY

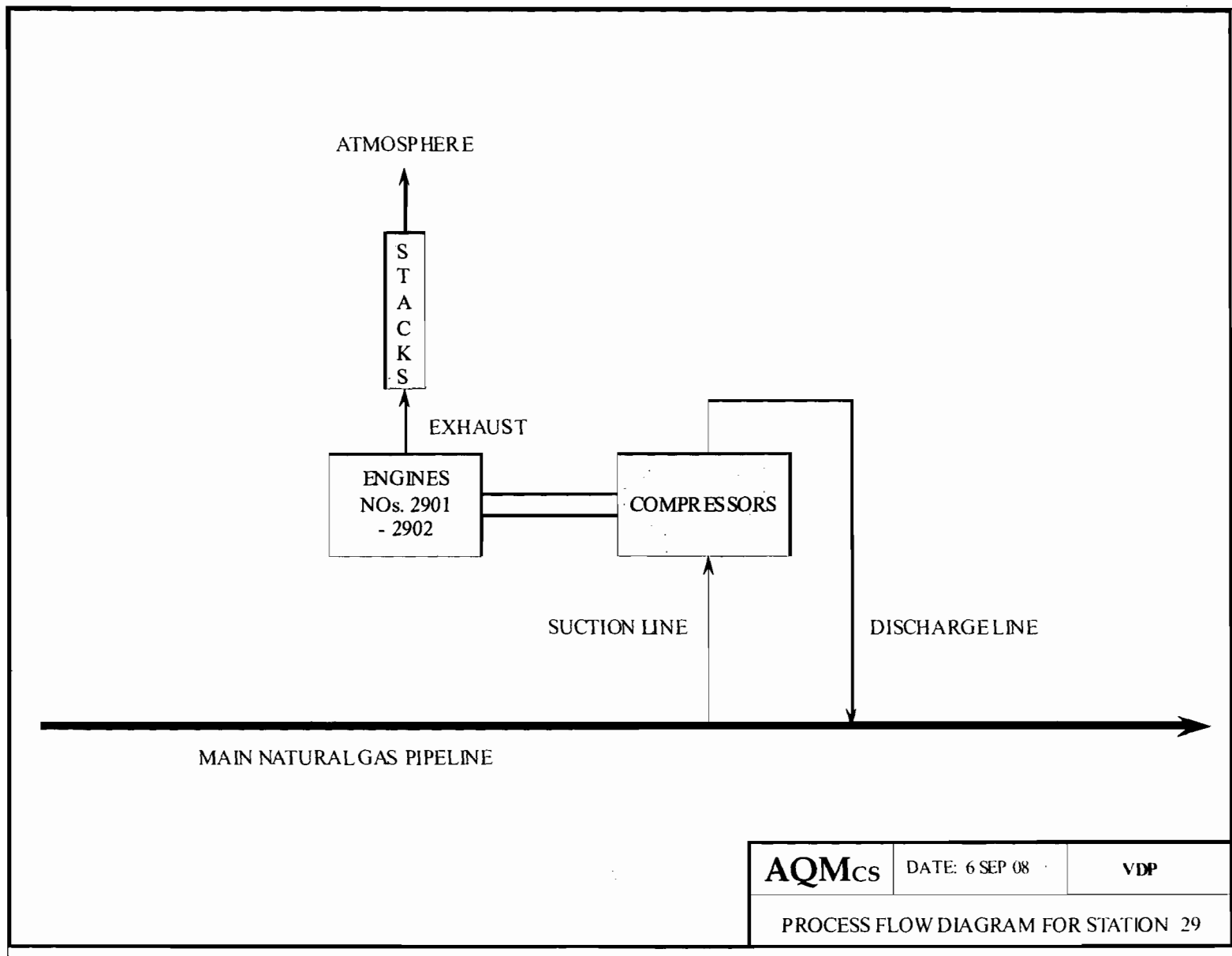



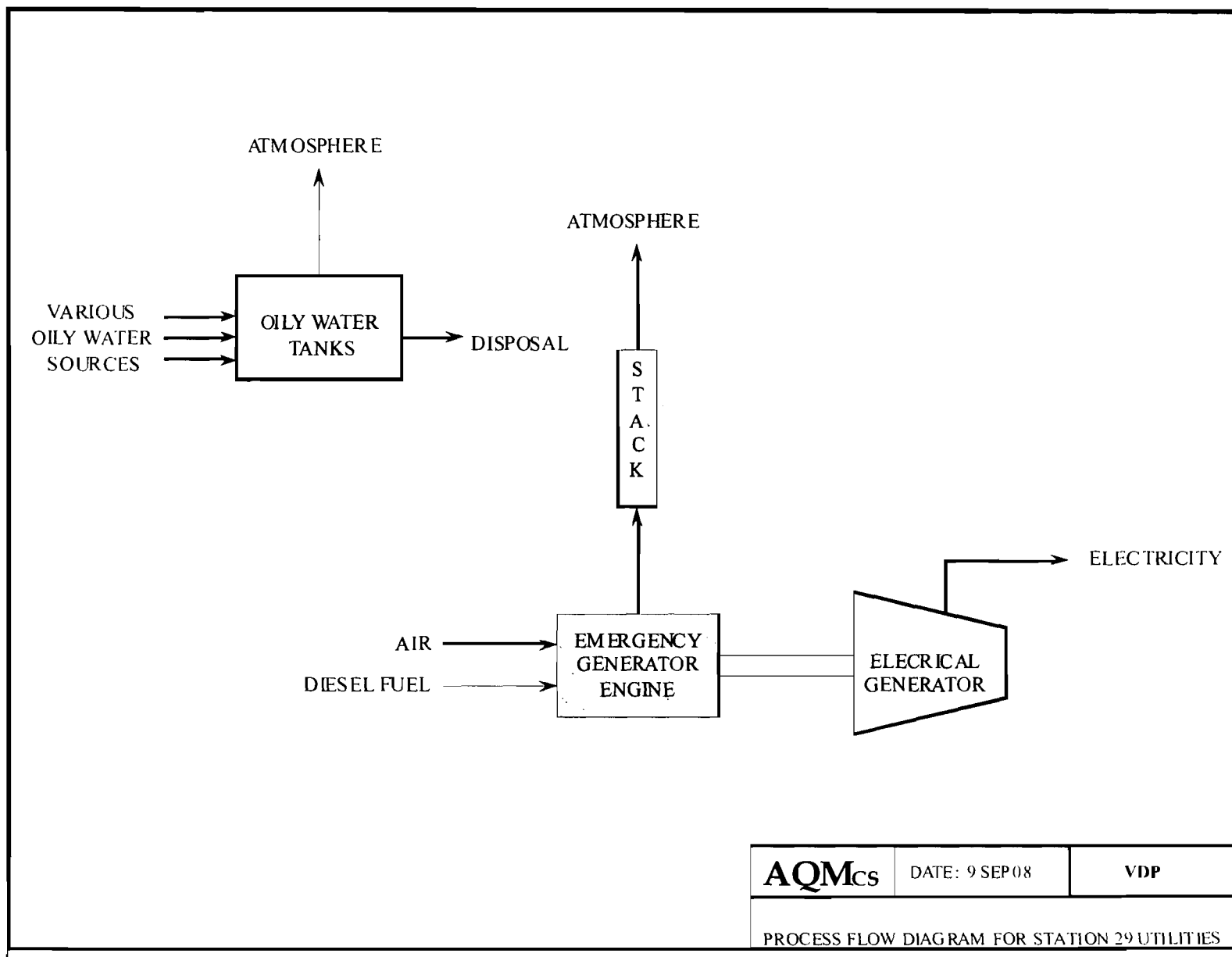

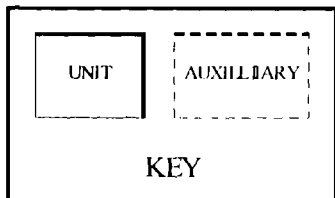
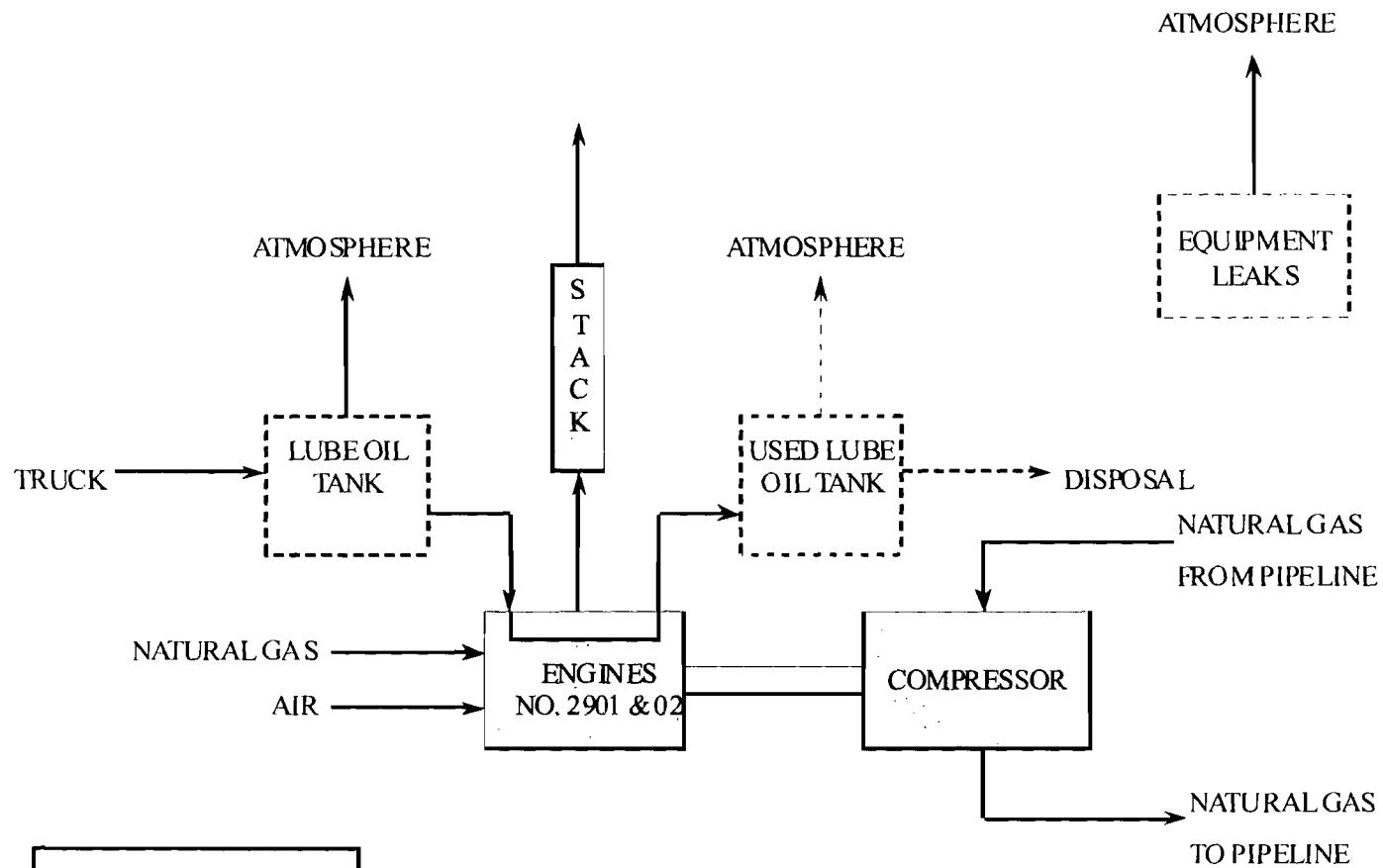

|       |                |     |
|-------|----------------|-----|
| AQMcs | DATE: 9 SEP 08 | VDP |
|-------|----------------|-----|

PROCESS FLOW DIAGRAM FOR EUs 2901 & 2902

## **Attachment C**

### **Precautions to Prevent Emissions of Unconfined Particulate Matter**

## **Precautions to Prevent Emissions of Unconfined Particulate Matter**

Precautions that will be taken to prevent unconfined emissions of unconfined particulate matter include:

- a) Chemical or water application to unpaved roads and unpaved yard areas;
- b) Paving and maintenance of roads, parking areas and yards; Landscaping or planting of vegetation;
- d) Other techniques, as necessary.

**Attachment D**

**Plot Plan**

**PLOT PLAN NEEDED**

**Attachment E**

**Vendor Information**

**Solar Model Taurus T-7800S Turbine**

**Generac SG300**

**Solar Model Taurus T-7800S Turbine**



# Solar Turbines

A Caterpillar Company

## PREDICTED EMISSION PERFORMANCE

|                                |                              |
|--------------------------------|------------------------------|
| Customer<br><b>FGT</b>         |                              |
| Job ID<br><b>HO08-0024</b>     |                              |
| Inquiry Number                 |                              |
| Run By<br><b>James Belmont</b> | Date Run<br><b>10-Jul-08</b> |

|  |                              |
|--|------------------------------|
| Engine Model<br><b>TAURUS 60-7800S</b><br><b>CS/MD 59F MATCH</b> |                              |
| Fuel Type<br><b>SD NATURAL GAS</b>                               | Water Injection<br><b>NO</b> |
| Engine Emissions Data<br><b>REV. 0.1</b>                         |                              |

|                      |                     |                      |
|----------------------|---------------------|----------------------|
| <b>NOx EMISSIONS</b> | <b>CO EMISSIONS</b> | <b>UHC EMISSIONS</b> |
|----------------------|---------------------|----------------------|

| 1                       | 7277 Hp | 100.0% Load | Elev. 0 ft | Rel. Humidity 60.0% | Temperature 59.0 Deg. F |
|-------------------------|---------|-------------|------------|---------------------|-------------------------|
| PPMvd at 15% O2         |         |             | 25.00      | 50.00               | 25.00                   |
| ton/yr                  |         |             | 26.44      | 32.20               | 9.22                    |
| lbm/MMBtu (Fuel LHV)    |         |             | 0.100      | 0.121               | 0.035                   |
| lbm/(MW-hr)             |         |             | 1.11       | 1.35                | 0.39                    |
| (gas turbine shaft pwr) |         |             |            |                     |                         |
| lbm/hr                  |         |             | 6.04       | 7.35                | 2.11                    |

|   |  |
|---|--|
| <b>Notes</b>  |  |
| <ol style="list-style-type: none"> <li>For short-term emission limits such as lbs/hr., Solar recommends using "worst case" anticipated operating conditions specific to the application and the site conditions. Worst case for one pollutant is not necessarily the same for another.</li> <li>Solar's typical SoLoNOx warranty, for ppm values, is available for greater than 0 deg F, and between 50% and 100% load for gas fuel, and between 65% and 100% load for liquid fuel (except for the Centaur 40). An emission warranty for non-SoLoNOx equipment is available for greater than 0 deg F and between 30% and 100% load.</li> <li>Fuel must meet Solar standard fuel specification ES 9-98. Emissions are based on the attached fuel composition, or, San Diego natural gas or equivalent.</li> <li>If needed, Solar can provide Product Information Letters to address turbine operation outside typical warranty ranges, as well as non-warranted emissions of SO2, PM10/2.5, VOC, and formaldehyde.</li> <li>Solar can provide factory testing in San Diego to ensure the actual unit(s) meet the above values within the tolerances quoted. Pricing and schedule impact will be provided upon request.</li> <li>Any emissions warranty is applicable only for steady-state conditions and does not apply during start-up, shut-down, malfunction, or transient event.</li> </ol> |  |

# Solar Turbines

A Caterpillar Company

## PREDICTED ENGINE PERFORMANCE

|                                       |                                      |
|---------------------------------------|--------------------------------------|
| Customer:<br><b>FGT</b>               |                                      |
| Job ID:<br>HO08-0024                  |                                      |
| Run By:<br>James Belmont              | Date Run:<br>10-Jul-08               |
| Engine Performance Code:<br>REV. 3.40 | Engine Performance Data:<br>REV. 0.7 |

|                                     |
|-------------------------------------|
| Model:<br><b>TAURUS 60-7800S</b>    |
| Package Type:<br>CS/MD              |
| Match:<br><b>59F MATCH</b>          |
| Fuel System:<br><b>GAS</b>          |
| Fuel Type:<br><b>SD NATURAL GAS</b> |

### DATA FOR MINIMUM PERFORMANCE

|                          |           |        |
|--------------------------|-----------|--------|
| Elevation                | feet      | 0      |
| Inlet Loss               | in H2O    | 4.0    |
| Exhaust Loss             | in H2O    | 4.0    |
| Accessory on GP Shaft    | HP        | 14.0   |
| Engine Inlet Temperature | deg F     | 59.0   |
| Relative Humidity        | %         | 60.0   |
| Driven Equipment Speed   | RPM       | 13854  |
| Specified Load           | HP        | FULL   |
| Net Output Power         | HP        | 7277   |
| Fuel Flow                | mmBtu/hr  | 60.59  |
| Heat Rate                | Btu/HP-hr | 8326   |
| Therm Eff                | %         | 30.561 |
| Engine Exhaust Flow      | lbm/hr    | 170003 |
| Exhaust Temperature      | deg F     | 956    |

|  |                        |        |
|--|------------------------|--------|
| Fuel Gas Composition<br>(Volume Percent) | Methane (CH4)          | 92.79  |
|  | Ethane (C2H6)          | 4.16   |
|  | Propane (C3H8)         | 0.84   |
|  | N-Butane (C4H10)       | 0.18   |
|  | N-Pentane (C5H12)      | 0.04   |
|  | Hexane (C6H14)         | 0.04   |
|  | Carbon Dioxide (CO2)   | 0.44   |
|  | Hydrogen Sulfide (H2S) | 0.0001 |
| Nitrogen (N2)                            | 1.51                   |        |

|                     |               |       |                  |        |                    |        |
|---------------------|---------------|-------|------------------|--------|--------------------|--------|
| Fuel Gas Properties | LHV (Btu/Scf) | 939.2 | Specific Gravity | 0.5970 | Wobbe Index at 60F | 1215.6 |
|---------------------|---------------|-------|------------------|--------|--------------------|--------|

*This performance was calculated with a basic inlet and exhaust system. Special equipment such as low noise silencers, special filters, heat recovery systems or cooling devices will affect engine performance. Performance shown is "Expected" performance at the pressure drops stated, not guaranteed.*

**Generac SG300**

# GENERAC®

## POWER SYSTEMS, INC.

### STATEMENT OF EXHAUST EMISSIONS NAT GAS FUELED GENERATOR

The measured emission values provided here are proprietary to Generac and its authorized dealers. This information may only be disseminated upon request, to regulatory governmental bodies for emissions permitting purposes or to specifying organizations as submittal data when expressly required by project specifications, and shall remain confidential and not open to public viewing. This information is not intended for compilation or sales purposes and may not be used as such, nor may it be reproduced without the expressed written permission of Generac Power Systems, Inc. The data provided shall not be meant to include information made public by Generac.

|   |  |
|---|--|
| Generator Type: <b>SG300</b>                                    | kW <sub>e</sub> Rating: <b>300</b>       |
| Engine Size: <b>13.3 Liter</b>                                  | Maximum BHP: <b>454</b>                  |
| Engine Family: <b>Generac 13.3 Liter 6 Cylinder</b>             |  |
| Aspiration: <b>Turbocharged-aftercooled</b>                     |  |
| Speed (RPM): <b>2350 RPM</b>                                    |  |
| Additional Equipment Description: <b>Commercial Natural Gas</b> |  |
| Emissions Test <b>5 mode</b>                                    | Engine Certification: <b>No Catalyst</b> |

Measured Emissions (*grams/brake horsepower-hour*) based on parent engine @ 454 bhp

| CO    | NO <sub>x</sub> | HC   | THC + NO <sub>x</sub> |
|-------|-----------------|------|-----------------------|
| 118.3 | 2.12            | 2.91 | 5.03                  |

- The stated values are actual exhaust emission test measurements obtained from a unit representative of the generator type and engine described above.
- Values based on 5-mode testing are official data of record as submitted to regulatory agencies for certification purposes. Testing was conducted in accordance with prevailing EPA & CARB protocols, which are typically accepted by SCAQMD and other regional authorities.
- Values based on full load testing are provided for reference only due to 5-mode test data being unavailable. Data may be based on testing performed by either the engine supplier or Generac Power Systems.
- No emission values provided above are to be construed as guarantees of emission levels for any given Generac generator unit.
- Generac Power Systems reserves the right to revise this information without prior notice.
- Consult state and local regulatory agencies for specific permitting requirements.
- The emission performance data supplied by the equipment manufacturer is only one element required toward completion of the permitting and installation process. State and local regulations may vary on a case-by-case basis and must be consulted by the permit applicant/equipment owner prior to equipment purchase or installation. The data supplied herein by Generac Power Systems cannot be construed as a guarantee of installability of the generating set.

**INDUSTRIAL SALES**  
**P.O. BOX 8 • WAUKESHA, WI 53187 • 262-544-4800 • FAX 262-544-4854**

SSD. E6297W    Rev Date 8-28-06

# SG275 SG300

## Liquid Cooled Gas Engine Generator Sets

### Standby Power Rating

275 KW 60 Hz / 275 KVA 50 Hz

300 KW 60 Hz / 300 KVA 50 Hz

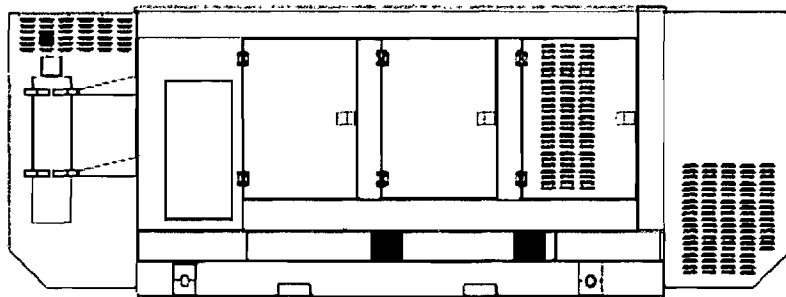

Power Matched  
**GENERAC**  
**13.3GTA ENGINE**  
Turbocharged/Aftercooled

## FEATURES

- **INNOVATIVE DESIGN & PROTOTYPE TESTING** are key components of GENERAC'S success in "IMPROVING POWER BY DESIGN." But it doesn't stop there. Total commitment to component testing, reliability testing, environmental testing, destruction and life testing, plus testing to applicable CSA, NEMA, EESSA, and other standards, allows you to choose GENERAC POWER SYSTEMS with the confidence that these systems will provide superior performance.
- **TEST CRITERIA:**
  - ✓ PROTOTYPE TESTED
  - ✓ SYSTEM TORSIONAL TESTED
  - ✓ ELECTRO-MAGNETIC INTERFERENCE
  - ✓ NEMA MG1 EVALUATION
  - ✓ MOTOR STARTING ABILITY
  - ✓ SHORT CIRCUIT TESTING
  - ✓ UL2200 COMPLIANCE AVAILABLE
- **SOLID-STATE, FREQUENCY COMPENSATED DIGITAL VOLTAGE REGULATION.** This state-of-the-art power maximizing regulation system is standard on all Generac models. It provides optimized **FAST RESPONSE** to changing load conditions and **MAXIMUM MOTOR STARTING CAPABILITY** by electronically torque-matching the surge loads to the engine.
- **SINGLE SOURCE SERVICE RESPONSE** from Generac's dealer network provides parts and service know-how for the entire unit, from the engine to the smallest electronic component. You are never on your own when you own a GENERAC POWER SYSTEM.
- **GENERAC TRANSFER SWITCHES, SWITCHGEAR AND ACCESSORIES.** Long life and reliability is synonymous with GENERAC POWER SYSTEMS. One reason for this confidence is that the GENERAC product line includes its own transfer systems, accessories, switchgear and controls for total system compatibility.

# GENERAC®

---

## POWER SYSTEMS, INC.

# APPLICATION & ENGINEERING DATA

SG275/SG300

## GENERATOR SPECIFICATIONS

|  |                                |
|--|--------------------------------|
| TYPE .....                             | Four-pole, revolving field     |
| ROTOR INSULATION .....                 | Class H                        |
| STATOR INSULATION .....                | Class H                        |
| TOTAL HARMONIC DISTORTION .....        | <3.0%                          |
| TELEPHONE INFLUENCE FACTOR (TIF) ..... | <50                            |
| ALTERNATOR .....                       | Self-ventilated and drip-proof |
| BEARINGS (PRE-LUBED & SEALED) .....    | 2                              |
| COUPLING .....                         | Flexible Disc                  |
| LOAD CAPACITY (STANDBY) .....          | 100%                           |

*NOTE: Generator rating and performance in accordance with ISO8528-5, B5514, SAE J1349, ISO3046 and DIN271 standards.*

### EXCITATION SYSTEM

|                                      |                                    |
|--------------------------------------|------------------------------------|
| PERMANENT MAGNET PILOT EXCITER ..... | Eighteen-pole exciter ✓            |
|                                      | Magnetically coupled DC current ✓  |
|                                      | Mounted outboard of main bearing ✓ |
| REGULATION .....                     | H100 Controller Digital ✓          |
|                                      | 3 Phase Sensing, ± 1% regulation ✓ |

## GENERATOR FEATURES

- Revolving field heavy duty generator
- Directly connected to the engine
- Operating temperature rise 125 °C above a 40 °C ambient
- Insulation is Class H rated at 150 °C rise
- All prototype models have passed three phase short circuit testing
- PMG

## CONTROL PANEL FEATURES

- TWO FOUR LINE LCD DISPLAYS READ:
  - Voltage (all phases)
  - Power factor
  - kW
  - Engine speed
  - Run hours
  - Fault history
  - Coolant temperature
  - Low oil pressure shutdown
  - Overspeed
  - Low coolant level
  - Not in auto position (flashing light)
  - ATS selection
  - Current (all phases)
  - kW
  - Transfer switch status
  - Low fuel pressure
  - Service reminders
  - Oil pressure
  - Time and date
  - High coolant temperature shutdown
  - Overspeed
  - Low coolant level
  - Exercise speed
- INTERNAL FUNCTIONS:
  - FT function for alternator protection from the to neutral and line to the short circuits
  - Emergency stop
  - Programmable auto crank function
  - 2 wire start for any transfer switch
  - Communicates with the Generac HTS transfer switch
  - Built-in 7 day exerciser
  - Adjustable engine speed at exerciser
  - RS232 port for GenLink® control
  - RS485 port (remote communication)
  - CANbus addressable
  - Governor controller and voltage regulator are built into the master control board
  - Temperature range -40 °C to 70 °C

Rating definitions: Standby: Applicable for supplying emergency power for the duration of the utility power outage. No overload capacity is available for this rating. (All ratings in accordance with B5514, ISO3046 and DIN271). Prime/Unlimited Running Time: Applicable for supplying electric power in lieu of commercially purchased power. Prime power is the maximum power available at variable load. A 10% overload capacity is available for 1 hour in 12 hours. (All ratings in accordance with B5514, ISO3046, ISO3049 and DIN271).

## ENGINE SPECIFICATIONS

|                               |   |
|-------------------------------|---|
| MAKE .....                    | GENERAC                                     |
| MODEL .....                   | 13.9GTA                                     |
| CYLINDERS .....               | 8 In-line                                   |
| DISPLACEMENT .....            | 13.9 Liter (811 cu. in.)                    |
| BORE .....                    | 137 mm (5.39 in.)                           |
| STROKE .....                  | 150 mm (5.91 in.)                           |
| COMPRESSION RATIO .....       | 10.5:1                                      |
| INTAKE AIR .....              | Turbocharged/Air-cooled                     |
| NUMBER OF MAIN BEARINGS ..... | 7   |
| CONNECTING RODS .....         | 6-Carbon Steel                              |
| CYLINDER HEAD .....           | Cast Iron with Overhead Valve               |
| CYLINDER LINERS .....         | Wet/Replaceable                             |
| IGNITION .....                | Electronic CD1                              |
| PISTONS .....                 | Heat-Resistant Alloy with 4 Rings           |
| CRANKSHAFT .....              | Induction-Hardened, Die-Forged Carbon Steel |

### VALVE TRAIN

|                              |                                 |
|------------------------------|---------------------------------|
| LIFTER TYPE .....            | Solid                           |
| INTAKE VALVE MATERIAL .....  | Special Heat Resistant Steel    |
| EXHAUST VALVE MATERIAL ..... | Inconel Alloy High Temp.        |
| HARDENED VALVE SEATS .....   | High Temp. Alloy Stellite Faced |

### ENGINE GOVERNOR

|  |                |
|--|----------------|
| ELECTRONIC .....                                 | Standard       |
| FREQUENCY REGULATION, NO-LOAD TO FULL LOAD ..... | Isosynchronous |
| STEADY STATE REGULATION .....                    | ±0.25%         |

### LUBRICATION SYSTEM

|                          |                       |
|--------------------------|-----------------------|
| TYPE OF OIL PUMP .....   | Gear Driven           |
| OIL FILTER .....         | Full flow, cartridge  |
| CRANKCASE CAPACITY ..... | 27 Liters (7.13 gal.) |

### COOLING SYSTEM

|                            |                              |
|----------------------------|------------------------------|
| TYPE OF SYSTEM .....       | Pressurized, closed recovery |
| WATER PUMP .....           | Pre-lubed, self-sealing      |
| TYPE OF FAN .....          | Pusher                       |
| NUMBER OF FAN BLADES ..... | 8                            |
| DIAMETER OF FAN .....      | 39 in.                       |
| COOLANT HEATER .....       | 240V, 2000 W                 |

### FUEL SYSTEM

|                                       |   |          |
|---------------------------------------|---|----------|
| FUEL                                  | <ul style="list-style-type: none"> <li><input type="checkbox"/> Natural Gas .....</li></ul> | Standard |
| CARBURETOR .....                      | Down draft  |          |
| SECONDARY FUEL REGULATOR .....        | No L Gas  |          |
| AUTOMATIC FUEL LOCKOFF SOLENOID ..... | Standard  |          |
| OPERATING FUEL PRESSURE SYSTEMS ..... | 10" to 15" H <sub>2</sub> O   |          |

### ELECTRICAL SYSTEM

|                                 |                         |
|---------------------------------|-------------------------|
| BATTERY CHARGE ALTERNATOR ..... | 20 Amps at 24 V         |
| STARTER MOTOR .....             | 24 V                    |
| RECOMMENDED BATTERY .....       | (2) - 12 V, 925 CCA, 31 |
| GROUND POLARITY .....           | Negative                |

**SG275/SG300**

| <b>OPERATING DATA</b>   |   | <b>SG275</b>    |                  | <b>SG300</b>    |                  |
|---|---|-----------------|------------------|-----------------|------------------|
| <b>GENERATOR OUTPUT VOLTAGE/KW-60HZ</b>                                 |   | <b>KW</b>       | <b>Rated AMP</b> | <b>KW</b>       | <b>Rated AMP</b> |
| 120/208V, 3-phase, 0.8 pf   | NOTE: Consult your Generator dealer for additional voltage. | 275             | 564              | 300             | 1041             |
| 120/240V, 3-phase, 0.8 pf   |   | 275             | 827              | 300             | 902              |
| 277/480V, 3-phase, 0.8 pf   |   | 275             | 413              | 300             | 451              |
| 600V, 3-phase, 0.8 pf   |   | 275             | 331              | 300             | 361              |
| <b>MOTOR STARTING</b>   |   |                 |                  |                 |                  |
| Maximum at 35% instantaneous voltage dip with standard alternator—60 HZ |   | <b>208/240V</b> | <b>480V</b>      | <b>208/240V</b> | <b>480V</b>      |
| with optional alternator—60 HZ  |   | 800 KVA         | 1060 KVA         | 800 KVA         | 1060 KVA         |
|   |   | 1000 KVA        | 1350 KVA         | 1000 KVA        | 1350 KVA         |
| <b>FUEL</b>   |   | <b>N.G.</b>     |                  | <b>N.G.</b>     |                  |
| Fuel consumption—60 HZ—100% Load ft. <sup>3</sup> /hr.                  |   |                 |                  |                 |                  |
| No Load   |   | 906             |                  | 906             |                  |
| 25%   |   | 1567            |                  | 1671            |                  |
| 50%   |   | 2253            |                  | 2376            |                  |
| 75%   |   | 3000            |                  | 3189            |                  |
| 100%  |   | 3792            |                  | 4100            |                  |
| <b>COOLING</b>  |   |                 |                  |                 |                  |
| Coolant capacity  | System fill (US gal.)                                       | 56.8 (15)       |                  | 56.8 (15)       |                  |
| Coolant flow/min.   | 60 HZ US gal.   | 138             |                  | 139             |                  |
| Heat rejection to coolant   | BTU/hr.   | 1,046,600       |                  | 1,048,250       |                  |
| Inlet air   | 60 HZ (cfm)   | 19,200          |                  | 19,200          |                  |
| Max. operating air temp. onto radiator                                  | °C (°F)   | 60 (140)        |                  | 60 (140)        |                  |
| Max. operating ambient temp.  | °C (°F)   | 50 (122)        |                  | 50 (122)        |                  |
| Max. external pressure drop on rad.                                     | in. H <sub>2</sub> O  | 0.5             |                  | 0.5             |                  |
| <b>COMBUSTION AIR REQUIREMENTS</b>                                      |   |                 |                  |                 |                  |
| Flow at rated power   | 60 HZ m <sup>3</sup> /min. (cfm)                            | 31.1 (1100)     |                  | 34 (1200)       |                  |
| <b>EXHAUST</b>  |   |                 |                  |                 |                  |
| Exhaust flow at rated output  | 60 HZ m <sup>3</sup> /min. (cfm)                            | 112 (3960)      |                  | 122 (4335)      |                  |
| Max. recommended back pressure  | Kpa (Hg)  | 5.0 (1.5")      |                  | 5.0 (1.5")      |                  |
| Exhaust temp. at rated output   | °F  | 1470            |                  | 1490            |                  |
| Exhaust outlet size   | (flange)  | 4" I.D.         |                  | 4" I.D.         |                  |
| <b>ENGINE</b>   |   |                 |                  |                 |                  |
| Rated RPM   | 60 HZ   | 2300            |                  | 2300            |                  |
| HP at rated KW  | 60 HZ   | 419             |                  | 454             |                  |
| Piston speed  | 60 HZ m/min. (ft./min.)                                     | 690 (2265)      |                  | 690 (2265)      |                  |
| BMEP  | 60 HZ   | 178             |                  | 193             |                  |
| <b>DERATION FACTORS</b>   |   |                 |                  |                 |                  |
| Temperature   |   |                 |                  |                 |                  |
| 1.9% for every 10°C above - °C  |   | 40              |                  | 40              |                  |
| 1.1% for every 10°F above - °F  |   | 104             |                  | 104             |                  |
| Altitude  |   |                 |                  |                 |                  |
| 0.7% for every 100 m above - m  |   | 1220            |                  | 1067            |                  |
| 2.1% for every 1000 ft. above - ft.                                     |   | 4000            |                  | 3500            |                  |

## STANDARD ENGINE & SAFETY FEATURES

SG275/SG300

- High Coolant Temperature Automatic Shutdown
- Low Coolant Level Automatic Shutdown
- Low Oil Pressure Automatic Shutdown
- Overspeed Automatic Shutdown (Solid-state)
- Crank Limiter (Solid-state)
- Oil Drain Extension
- Radiator Drain Extension
- Factory-Installed Cool Flow Radiator
- Closed Coolant Recovery System
- UV/Ozone Resistant Hoses
- Rubber-Booted Engine Electrical Connections
- Isochronous Governor

- Fuel Lockoff Solenoid
- Secondary Fuel Regulator (N.G.)
- Stainless Steel Flexible Exhaust Connection
- Battery Charge Alternator
- Battery Cables
- Battery Tray
- Vibration Isolation of Unit to Mounting Base
- 24 Volt, Solenoid-Activated Starter Motor
- Air Cleaner
- Fan Guard
- Control Consoles (H100)

## OPTIONS

- **OPTIONAL COOLING SYSTEM ACCESSORIES**
  - Radiator Duct Adapter

- **OPTIONAL FUEL ACCESSORIES**
  - Flexible Fuel Lines

- **OPTIONAL EXHAUST ACCESSORIES**
  - Critical Exhaust Silencer

- **OPTIONAL ELECTRICAL ACCESSORIES**
  - Battery, (2) - 12 Volt, 135 A.H., 4DLT
  - Battery, (2) - 12 Volt, 225 A.H., 8D
  - Battery Heater
  - 2A Battery Charger
  - 10A Dual Pole Battery Charger

- **OPTIONAL ALTERNATOR ACCESSORIES**
  - Alternator Strip Heater
  - Alternator Tropicalization
  - Main Line Circuit Breaker

- **CONTROL CONSOLE OPTIONS**
  - Digital Controller H100 see specification 01721105BY

- **ADDITIONAL OPTIONAL EQUIPMENT**
  - Automatic Transfer Switch (GTS or HTS)
  - 20 Light Remote Annunciator
  - Remote Relay Panels
  - Unit Vibration Isolators
  - Oil Make-Up System
  - Oil Heater
  - 5 Year Warranties
  - Export Wiring
  - GenLink® Communications Software

- **OPTIONAL ENCLOSURES**
  - Weather Protective
  - Sound Attenuated
  - Aluminum and Stainless Steel
  - Enclosed Muffler

Distributed by:

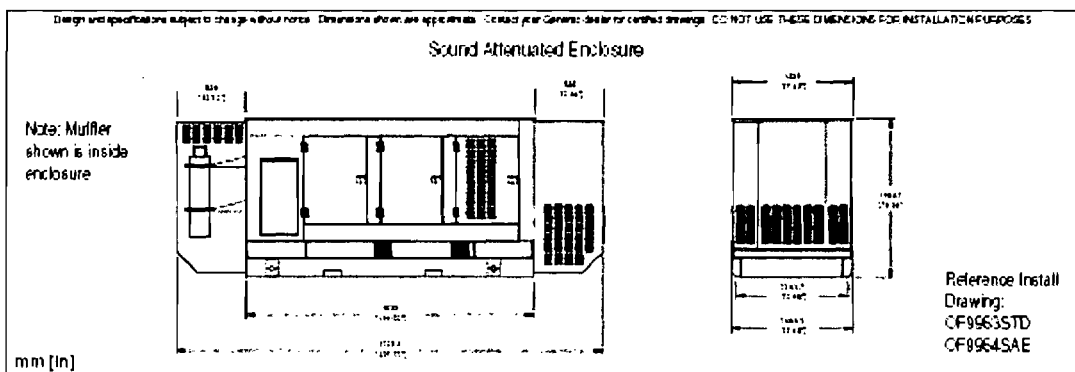

**GENERAC® POWER SYSTEMS, INC.** • P.O. BOX 8 • WAUKESHA, WI 53187

262/544-4811 • FAX 262/544-4851

Bulletin 01725400EY • Printed in USA 04 07

© 2007 Generac Power Systems, Inc. All rights reserved. All specifications subject to change without notice.



**Attachment F**  
**Emission Calculations**

**Compressor Station No. 29**

**Engine No. 2901/2902 EPN: 001/002**

**NOx Emissions: (Based on Vendor Data)**

$$\text{lb NOx/hr} = 6.04$$

$$\begin{aligned} \text{tons NOx/yr} &= (\text{lb NOx/hr})(2000 \text{ lb/1 ton})(8760 \text{ hr/1 yr}) \\ &= (6.04 \text{ lb/hr})(2000 \text{ lb/1 ton})(8760 \text{ hr/yr}) \\ &= 26.455 \end{aligned}$$

**CO Emissions: (Based on Vendor Data)**

$$\text{lb CO/hr} = 7.35$$

$$\begin{aligned} \text{tons CO/yr} &= (\text{lb CO/hr})(2000 \text{ lb/1 ton})(8760 \text{ hr/1 yr}) \\ &= (7.35 \text{ lb/hr})(2000 \text{ lb/1 ton})(8760 \text{ hr/yr}) \\ &= 32.193 \end{aligned}$$

**VOC Emissions: (Based on Vendor Data)**

$$\text{lb UHC/hr} = 2.110$$

$$\begin{aligned} \text{lb VOC/yr} &= (0.211 \text{ UHC lb/hr}) * (\text{VOC fraction of } 0.1) \\ &= 0.211 \end{aligned}$$

$$\begin{aligned} \text{tons VOC/yr} &= (\text{lb VOC/hr})(2000 \text{ lb/1 ton})(8760 \text{ hr/1 yr}) \\ &= (0.21 \text{ lb/hr})(2000 \text{ lb/1 ton})(8760 \text{ hr/yr}) \\ &= 0.924 \end{aligned}$$

**SO2 Emissions: (Based on FERC Limits)**

$$\begin{aligned} \text{lb S/hr} &= (\text{gr S/100 scf})(\text{MMscf/hr})(1 \text{ lb/7000 gr}) \\ &= (10 \text{ gr S/100 scf})(0.0645 \text{ MMscf/hr})(1 \text{ lb/7000 gr}) \\ &= 0.922 \end{aligned}$$

$$\begin{aligned} \text{lb SO2/hr} &= (\text{lb S/hr})(2 \text{ lb SO2/lb S}) \\ &= (0.92 \text{ lb S/hr})(2 \text{ lb SO2/lb S}) \\ &= 1.843 \end{aligned}$$

$$\begin{aligned} \text{tons SO2/yr} &= (\text{lb SO2/hr})(\text{hr/yr})(1 \text{ ton/2000 lb}) \\ &= (1.84 \text{ lb SO2/hr})(8760 \text{ hr/yr})(1 \text{ ton/2000 lb}) \\ &= 8.073 \end{aligned}$$

**PM 10/2.5 Emissions: (Based on AP-42 Table 3.1-2a, 4/00)**

$$\begin{aligned} \text{lb PM/hr} &= (\text{lb PM/MMBtu})(\text{MMBtu/hr}) \\ &= (0.0066 \text{ lb/MMBtu})(67.09 \text{ MMBtu/hr}) \\ &= 0.443 \end{aligned}$$

$$\begin{aligned} \text{tons PM/yr} &= (\text{lb PM/hr})(\text{hr/yr})(1 \text{ ton/2000 lb}) \\ &= (0.44 \text{ lb PM/hr})(8760 \text{ hr/yr})(1 \text{ ton/2000 lb}) \\ &= 1.939 \end{aligned}$$

**HAPs Emissions: (Based on AP-42 Table 3.1-3, 4/00)**

$$\begin{aligned} \text{lb HAP/hr} &= (\text{lb HAP/MMBtu})(\text{MMBtu/hr}) \\ &= (0.00102700 \text{ lb/MMBtu})(67.090 \text{ MMBtu/hr}) \\ &= 0.069 \end{aligned}$$

$$\begin{aligned} \text{tons HAP/yr} &= (\text{lb HAP/hr})(\text{hr/yr})(1 \text{ ton/2000 lb}) \\ &= (0.069 \text{ lb HAP/hr})(8760 \text{ hr/yr})(1 \text{ ton/2000 lb}) \\ &= 0.302 \end{aligned}$$

## Emergency Gen. Nos. 1 & 2 EPNs: 003 & 004

### NOx Emissions: (Based on Vendor Data)

$$\begin{aligned}\text{lb NOx/hr} &= (\text{g/bhp-hr})(\text{bhp})(1 \text{ lb}/453.59 \text{ g}) \\ &= (2.12 \text{ g/bhp-hr})(454 \text{ bhp})(1 \text{ lb}/453.59 \\ &= \text{g}) \\ &= 2.122 \\ \text{Control Effic.} &= 5.7\% \\ \text{Controlled NOx lb/hr} &= 2.00 \\ \\ \text{tons NOx/yr} &= (\text{lb NOx/hr})(\text{hr/yr})(1 \text{ ton}/2000 \text{ lb}) \\ &= (2.12 \text{ lb NOx/hr})(100 \text{ hr/yr})(1 \text{ ton}/2000 \\ &= \text{lb}) \\ &= 0.1061 \\ \text{Control Effic.} &= 5.7\% \\ \text{Controlled NOx tpy} &= 0.10\end{aligned}$$

### CO Emissions: (Based on Vendor Data)

$$\begin{aligned}\text{lb CO/hr} &= (\text{g/bhp-hr})(\text{bhp})(1 \text{ lb}/453.59 \text{ g}) \\ &= (118.3 \text{ g/bhp-hr})(454 \text{ bhp})(1 \text{ lb}/453.59 \\ &= \text{g}) \\ &= 118.404 \\ \text{Control Effic.} &= 96.6\% \\ \text{Controlled CO lb/hr} &= 4.03 \\ \\ \text{tons CO/yr} &= (\text{lb CO/hr})(\text{hr/yr})(1 \text{ ton}/2000 \text{ lb}) \\ &= (118.40 \text{ lb CO/hr})(100 \text{ hr/yr})(1 \\ &= \text{ton}/2000 \text{ lb}) \\ &= 5.92 \\ \text{Control Effic.} &= 96.6\% \\ \text{Controlled CO tpy} &= 0.20\end{aligned}$$

### VOC Emissions: (Based on Vendor Data)

$$\begin{aligned}\text{lb VOC/hr} &= (\text{g/bhp-hr})(\text{bhp})(1 \text{ lb}/453.59 \text{ g}) \\ &= (0.29 \text{ g/bhp-hr})(454 \text{ bhp})(1 \text{ lb}/453.59 \\ &= \text{g}) \\ &= 0.290 \\ \text{Control Effic.} &= 0\% \\ \text{Controlled VOC lb/hr} &= 0.290 \\ \\ \text{tons VOC/yr} &= (\text{lb VOC/hr})(\text{hr/yr})(1 \text{ ton}/2000 \text{ lb}) \\ &= (0.29 \text{ lb VOC/hr})(100 \text{ hr/yr})(1 \text{ ton}/2000 \\ &= \text{lb}) \\ &= 0.0145 \\ \text{Control Effic.} &= 0\% \\ \text{Controlled CO tpy} &= 0.0145\end{aligned}$$

### SO2 Emissions: (Based on FERC Limits)

$$\begin{aligned}\text{lb S/hr} &= (\text{gr S}/100 \text{ scf})(\text{MMscf/hr})(1 \text{ lb}/7000 \text{ gr}) \\ &= (10 \text{ gr S}/100 \text{ scf})(0.0041 \text{ MMscf/hr})(1 \text{ lb}/7000 \\ &= \text{gr}) \\ &= 0.059 \\ \\ \text{lb SO2/hr} &= (\text{lb S/hr})(2 \text{ lb SO2}/\text{lb S}) \\ &= (0.06 \text{ lb S/hr})(2 \text{ lb SO2}/\text{lb S}) \\ &= 0.117 \\ \\ \text{tons SO2/yr} &= (\text{lb SO2/hr})(\text{hr/yr})(1 \text{ ton}/2000 \text{ lb}) \\ &= (0.117 \text{ lb SO2/hr})(100 \text{ hr/yr})(1 \text{ ton}/2000 \text{ lb}) \\ &= 0.006\end{aligned}$$

### PM Emissions: (Based on AP-42 Table 3.2-3, 7/00)

$$\begin{aligned}\text{lb PM/hr} &= (\text{lb PM}/\text{MMBtu})(\text{MMBtu/hr}) \\ &= (0.01941 \text{ MMBtu/hr})(4.26 \text{ MMBtu/hr}) \\ &= 0.083 \\ \\ \text{tons PM/yr} &= (\text{lb PM/hr})(\text{hr/yr})(1 \text{ ton}/2000 \text{ lb}) \\ &= (0.083 \text{ lb PM/hr})(100 \text{ hr/yr})(1 \text{ ton}/2000 \text{ lb}) \\ &= 0.0041\end{aligned}$$

### HAPs Emissions: (Based on AP-42 Table 3.2-3, 7/00)

$$\begin{aligned}\text{lb HAP/hr} &= (\text{lb HAP}/\text{MMBtu})(\text{MMBtu/hr}) \\ &= (0.0234 \text{ lb}/\text{MMBtu})(4.26 \text{ MMBtu/hr}) \\ &= 0.0997 \\ \\ \text{tons HAP/yr} &= (\text{lb HAP/hr})(\text{hr/yr})(1 \text{ ton}/2000 \text{ lb}) \\ &= (0.10 \text{ lb HAP/hr})(100 \text{ hr/yr})(1 \text{ ton}/2000 \text{ lb}) \\ &= 0.005\end{aligned}$$

**TANKS 4.0.9d**  
**Emissions Report - Summary Format**  
**Tank Identification and Physical Characteristics**

**Identification**  
 User Identification: FGT CS 29 Oily Water  
 City: Okochobee  
 State: Florida  
 Company: Florida Gas Transmission  
 Type of Tank: Vertical Fixed Roof Tank  
 Description:

**Tank Dimensions**  
 Shell Height (ft): 6.00  
 Diameter (ft): 4.00  
 Liquid Height (ft): 6.00  
 Avg. Liquid Height (ft): 3.00  
 Volume (gallons): 564.02  
 Turnovers: 0.89  
 Net Throughput(gal/yr): 500.00  
 Is Tank Heated (y/n): N

**Paint Characteristics**  
 Shell Color/Shade: White/White  
 Shell Condition: Good  
 Roof Color/Shade: White/White  
 Roof Condition: Good

**Roof Characteristics**  
 Type: Cone  
 Height (ft): 0.00  
 Slope (ft/ft) (Cone Roof): 0.06

**Breather Vent Settings**  
 Vacuum Settings (psig): -0.03  
 Pressure Settings (psig): 0.03

Meterological Data used in Emissions Calculations: Vero Beach, Florida (Avg Atmospheric Pressure = 14.75 psia)

**TANKS 4.0.9d**  
**Emissions Report - Summary Format**  
**Liquid Contents of Storage Tank**

**FGT CS 29 Oily Water - Vertical Fixed Roof Tank**  
**Okochobee, Florida**

| Mixture/Component | Month | Daily Liquid Surf. Temperature (deg F) |       |       | Liquid Bulk Temp (deg F) | Vapor Pressure (psia) |        |        | Vapor Mol. Weight | Liquid Mass Fract. | Vapor Mass Fract. | Mol. Weight | Basis for Vapor Pressure Calculations |
|-------------------|-------|--|-------|-------|--------------------------|-----------------------|--------|--------|-------------------|--------------------|-------------------|-------------|---------------------------------------|
|                   |       | Avg.                                   | Min.  | Max.  |                          | Avg.                  | Min.   | Max.   |                   |                    |                   |             |                                       |
| Lube Oil          | All   | 74.17                                  | 69.18 | 79.16 | 72.43                    | 0.0001                | 0.0001 | 0.0001 | 190.0000          |                    |                   | 190.00      | Option 1: VP70 = .00006 VP80 = .00009 |

**TANKS 4.0.9d**

**Emissions Report - Summary Format  
Individual Tank Emission Totals**

**Emissions Report for: Annual**

**FGT CS 29 Oily Water - Vertical Fixed Roof Tank  
Okochobee, Florida**

| Components | Losses(lbs)  |                | Total Emissions |
|------------|--------------|----------------|-----------------|
|            | Working Loss | Breathing Loss |                 |
| Lube Oil   | 0.00         | 0.00           | 0.00            |

**TANKS 4.0.9d**  
**Emissions Report - Summary Format**  
**Tank Identification and Physical Characteristics**

**Identification**

User Identification: FGT CS 29 Condensate  
 City: Okochobee  
 State: Florida  
 Company: Florida Gas Transmission  
 Type of Tank: Vertical Fixed Roof Tank  
 Description:

**Tank Dimensions**

Shell Height (ft): 12.00  
 Diameter (ft): 8.00  
 Liquid Height (ft) : 12.00  
 Avg. Liquid Height (ft): 6.00  
 Volume (gallons): 4,512.16  
 Turnovers: 0.01  
 Net Throughput(gal/yr): 50.00  
 Is Tank Heated (y/n): N

**Paint Characteristics**

Shell Color/Shade: White/White  
 Shell Condition: Good  
 Roof Color/Shade: White/White  
 Roof Condition: Good

**Roof Characteristics**

Type: Cone  
 Height (ft) 0.00  
 Slope (ft/ft) (Cone Roof) 0.06

**Breather Vent Settings**

Vacuum Settings (psig): -0.03  
 Pressure Settings (psig) 0.03

Meteorological Data used in Emissions Calculations: Vero Beach, Florida (Avg Atmospheric Pressure = 14.75 psia)

**TANKS 4.0.9d**  
**Emissions Report - Summary Format**  
**Liquid Contents of Storage Tank**

**FGT CS 29 Condensate - Vertical Fixed Roof Tank**  
**Okochobee, Florida**

| Mixture/Component   | Month | Daily Liquid Surf. Temperature (deg F) |       |       | Liquid Bulk Temp (deg F) | Vapor Pressure (psia) |        |        | Vapor Mol. Weight. | Liquid Mass Fract. | Vapor Mass Fract. | Mol. Weight | Basis for Vapor Pressure Calculations |
|---------------------|-------|--|-------|-------|--------------------------|-----------------------|--------|--------|--------------------|--------------------|-------------------|-------------|---------------------------------------|
|                     |       | Avg.                                   | Min.  | Max.  |                          | Avg.                  | Min.   | Max.   |                    |                    |                   |             |                                       |
| Pipeline Condensate | All   | 74.17                                  | 69.18 | 79.16 | 72.43                    | 0.7115                | 0.6303 | 0.8013 | 53.0000            |                    |                   | 53.00       | Option 4: RVP=1.4                     |

**TANKS 4.0.9d**  
**Emissions Report - Summary Format**  
**Individual Tank Emission Totals**

**Emissions Report for: Annual**

**FGT CS 29 Condensate - Vertical Fixed Roof Tank**  
**Okochobee, Florida**

| Components          | Losses(lbs)  |                |                 |
|---------------------|--------------|----------------|-----------------|
|                     | Working Loss | Breathing Loss | Total Emissions |
| Pipeline Condensate | 0.03         | 27.08          | 27.12           |

---

**Attachment G**

**Fuel Analysis**



BEST AVAILABLE COPY

| FTWSCB1.ener         | East System Chromatographs |         |                     |         |         |                             |         |         | 01-Aug-2008 14:05:09 |
|----------------------|----------------------------|---------|---------------------|---------|---------|-----------------------------|---------|---------|----------------------|
|                      | CR15                       | BRO1    | CR18                | CR18    | CRJX    | GLAB                        | CRBB    | CR21    |                      |
| n-Hexanes +          | 0.0698                     | 0.0706  | 0.0627              | 0.0199  | 0.0058  | 0.0638                      | 0.0013  | 0.0453  |                      |
| Nitrogen             | 0.5661                     | 0.5581  | 0.5374              | 0.4067  | 0.0616  | 0.5267                      | 0.0184  | 0.4515  |                      |
| Methane              | 95.5536                    | 95.5834 | 95.5528             | 95.9043 | 96.5431 | 95.6856                     | 96.6087 | 95.6529 |                      |
| Carbon Dioxide       | 0.9859                     | 0.9896  | 0.9931              | 0.7936  | 0.1266  | 1.0224                      | 0.0153  | 0.7481  |                      |
| Ethane               | 2.2210                     | 2.2010  | 2.2452              | 2.3074  | 2.6850  | 2.1642                      | 2.7702  | 2.4459  |                      |
| Propane              | 0.3579                     | 0.3530  | 0.3637              | 0.3569  | 0.4396  | 0.3325                      | 0.4590  | 0.4177  |                      |
| Iso-Butane           | 0.0806                     | 0.0796  | 0.0814              | 0.0710  | 0.0704  | 0.0728                      | 0.0702  | 0.0854  |                      |
| n-Butane             | 0.0944                     | 0.0933  | 0.0947              | 0.0716  | 0.0563  | 0.0757                      | 0.0515  | 0.0923  |                      |
| Iso-Pentane          | 0.0406                     | 0.0411  | 0.0395              | 0.0270  | 0.0076  | 0.0333                      | 0.0039  | 0.0356  |                      |
| n-Pentane            | 0.0301                     | 0.0304  | 0.0295              | 0.0187  | 0.0038  | 0.0229                      | 0.0016  | 0.0253  |                      |
| Un-normalized Totals | 100.03                     |         | 99.91               | 99.78   | 100.08  |                             | 99.85   | 99.40   |                      |
| Specific Gravity     | 0.5869                     | 0.5873  | 0.5868              | 0.5831  | 0.5759  |                             | 0.5750  | 0.5850  |                      |
| BTU / cu. ft.        | 1030.2                     |         | 1030.4              | 1031.8  | 1043.2  |                             | 1045.2  | 1035.1  |                      |
|                      | CR15                       |         | BRO1                | CR18    | CRJX    | GLAB                        | CRBB    | CR21    |                      |
| Dew Point and H2S    | Recall                     |         | West Chromatographs |         |         | East On Line Chromatographs |         |         |                      |

**Attachment H**  
**List of Exempt Emissions Units**

### **List of Exempt Emissions Units**

1. 500 gallon Oily Water Storage Tank, vertical, 4' x 6'
2. Fugitive emissions from component leaks



Florida Gas Transmission Company

JPMorgan Chase Bank, N.A.

300092

5444 Westheimer Road  
Houston, TX 77056-5306

Syracuse, NY 13206  
50937/213

Date

11/21/2008

Pay Amount

\$2,250.00

Pay

TWO THOUSAND TWO HUNDRED FIFTY AND 00/100 DOLLARS

To The  
Order of

FLORIDA DEPARTMENT OF ENVIRONMENTAL PROTECTION  
2600 BLAIRSTONE, MS 5500  
TALLAHASSEE, FL 32399-2400

*May [Signature]*  
Authorized Signature



THE ORIGINAL DOCUMENT HAS A WHITE REFLECTIVE WATERMARK ON THE BACK. HOLD AT AN ANGLE TO SEE THE MARK WHEN CHECKING THE ENDORSEMENTS.

IRM NO. LTB-01

Check Date:

11/21/2008

Check No.:

300092

| Invoice Number | Invoice Date | Voucher ID | Gross Amount | Discount Available | Paid Amount |
|----------------|--------------|------------|--------------|--------------------|-------------|
|----------------|--------------|------------|--------------|--------------------|-------------|

APPLICATION FOR AIR CONSTRUCTION PERMIT - COMPRESSOR STATION 29

*Note: Vickie has original check looked up.*

RECEIVED

NOV 26 2008

BUREAU OF AIR REGULATION

| Vendor Number | Vendor Name |              | Total Discounts |                   |  |
|---------------|-------------|--------------|-----------------|-------------------|--|
|               |             |              |                 |                   |  |
| Check Number  | Date        | Total Amount | Discounts Taken | Total Paid Amount |  |
|               | 11/21/2008  |              |                 | \$2,250.00        |  |