



Wheelabrator North Broward Inc.

A Waste Management Company

2600 Wiles Road
Pompano Beach, FL 33073
(954) 971-8701 Tel
(954) 971-8703 Fax

RECEIVED

JUN 29 2010

BUREAU OF
AIR REGULATION

June 28, 2010

UPS # 1Z26X1501391407916

Trina Vielhauer, Chief
Bureau of Air Regulation
Florida Department of Environmental Protection
Twin Towers Office Building
2600 Blair Stone Road
Tallahassee, Florida 32399-2400

Re: Wheelabrator North Broward
Title V Permit No. 0112120-009-AV
Permit Renewal Application

Dear Ms. Vielhauer:

Project No. : 0112120-010-AV

Please find enclosed four copies of Wheelabrator North Broward's Title V permit renewal application.

I, the undersigned, am a responsible official, as defined in Rule 62-210.200, F.A.C., of the Title V source addressed in this submittal. I hereby certify, based on information and belief formed after reasonable inquiry, that the statements and information in this document are true, accurate and complete.

If there are any questions, or if further information is required, please contact myself or Chuck Faller at (954) 971-8701.

Sincerely,

Scott McIlvaine
Scott McIlvaine
Plant Manager

cc: Chuck Faller (with)
Tim Porter (without)
Rob French (with)
Ram Tewari (without)
Theodore S. Pytlar, Jr. (without)





Title V Air Operation Permit Renewal Application

A world of
capabilities
delivered locally

TITLE V AIR OPERATION PERMIT RENEWAL APPLICATION

Wheelabrator North Broward, Inc.

Submitted To: Wheelabrator North Broward, Inc.
2600 NW 48th Street
Pompano Beach, FL 33073

Submitted By: Golder Associates Inc.
6026 NW 1st Place
Gainesville, FL 32607 USA

Distribution: 4 copies FDEP
2 copies Wheelabrator North Broward, Inc.
2 copies Golder Associates Inc.

June 2010

103-87513-2



APPLICATION FOR AIR PERMIT

LONG FORM



Department of Environmental Protection

Division of Air Resource Management

APPLICATION FOR AIR PERMIT - LONG FORM

I. APPLICATION INFORMATION

RECEIVED

JUN 29 2010

BUREAU OF AIR REGULATION

Air Construction Permit – Use this form to apply for an air construction permit:

- For any required purpose at a facility operating under a federally enforceable state air operation permit (FESOP) or Title V air operation permit;
- For a proposed project subject to prevention of significant deterioration (PSD) review, nonattainment new source review, or maximum achievable control technology (MACT);
- To assume a restriction on the potential emissions of one or more pollutants to escape a requirement such as PSD review, nonattainment new source review, MACT, or Title V; or
- To establish, revise, or renew a plantwide applicability limit (PAL).

Air Operation Permit – Use this form to apply for:

- An initial federally enforceable state air operation permit (FESOP); or
- An initial, revised, or renewal Title V air operation permit.

To ensure accuracy, please see form instructions.

Identification of Facility

1. Facility Owner/Company Name: Wheelabrator North Broward, Inc.	
2. Site Name: Wheelabrator North Broward	
3. Facility Identification Number: 0112120	
4. Facility Location... Street Address or Other Locator: 2600 NW 48th Street City: Pompano Beach County: Broward Zip Code: 33073	
5. Relocatable Facility? <input type="checkbox"/> Yes <input checked="" type="checkbox"/> No	6. Existing Title V Permitted Facility? <input checked="" type="checkbox"/> Yes <input type="checkbox"/> No

Application Contact

1. Application Contact Name: Chuck Faller, Environmental Safety and Compliance Director	
2. Application Contact Mailing Address... Organization/Firm: Wheelabrator North Broward, Inc. Street Address: 2600 NW 48th Street City: Pompano Beach State: FL Zip Code: 33073	
3. Application Contact Telephone Numbers... Telephone: (954) 971-8701 ext. Fax: (954) 971-8703	
4. Application Contact E-mail Address: cfaller@wm.com	

Application Processing Information (DEP Use)

1. Date of Receipt of Application: 6-29-10	3. PSD Number (if applicable):
2. Project Number(s): 0112120-010-AV	4. Siting Number (if applicable):

APPLICATION INFORMATION

Purpose of Application

This application for air permit is being submitted to obtain: (Check one)

Air Construction Permit

- Air construction permit.
- Air construction permit to establish, revise, or renew a plantwide applicability limit (PAL).
- Air construction permit to establish, revise, or renew a plantwide applicability limit (PAL), and separate air construction permit to authorize construction or modification of one or more emissions units covered by the PAL.

Air Operation Permit

- Initial Title V air operation permit.
- Title V air operation permit revision.
- Title V air operation permit renewal.
- Initial federally enforceable state air operation permit (FESOP) where professional engineer (PE) certification is required.
- Initial federally enforceable state air operation permit (FESOP) where professional engineer (PE) certification is not required.

Air Construction Permit and Revised/Renewal Title V Air Operation Permit (Concurrent Processing)

- Air construction permit and Title V permit revision, incorporating the proposed project.
- Air construction permit and Title V permit renewal, incorporating the proposed project.

Note: By checking one of the above two boxes, you, the applicant, are requesting concurrent processing pursuant to Rule 62-213.405, F.A.C. In such case, you must also check the following box:

- I hereby request that the department waive the processing time requirements of the air construction permit to accommodate the processing time frames of the Title V air operation permit.

Application Comment

This application is to renew the facility's Title V Air Operation Permit No. 0112120-009-AV that has an expiration date of February 13, 2011. The planned wet scrubber in the ash handling building (EU006) is a regulated emission unit. However, it has not been installed yet and it is not included in the emissions units section.

APPLICATION INFORMATION

Scope of Application

Emissions Unit ID Number	Description of Emissions Unit	Air Permit Type	Air Permit Processing Fee
001	807 TPD MSW Combustor & Auxiliary Burners - Unit 1	AF2A	
002	807 TPD MSW Combustor & Auxiliary Burners - Unit 2	AF2A	
003	807 TPD MSW Combustor & Auxiliary Burners - Unit 3	AF2A	
004	236 Ton Lime Silo	AF2A	
005	Ash Handling System	AF2A	
006	Wet Scrubber in Ash Handling Building		

Application Processing Fee

Check one: Attached - Amount: \$ _____ Not Applicable

APPLICATION INFORMATION

Owner/Authorized Representative Statement

Complete if applying for an air construction permit or an initial FESOP.

1. Owner/Authorized Representative Name :	
2. Owner/Authorized Representative Mailing Address... Organization/Firm: Street Address: City: State: Zip Code:	
3. Owner/Authorized Representative Telephone Numbers... Telephone: () ext. Fax: ()	
4. Owner/Authorized Representative E-mail Address:	
5. Owner/Authorized Representative Statement: <i>I, the undersigned, am the owner or authorized representative of the corporation, partnership, or other legal entity submitting this air permit application. To the best of my knowledge, the statements made in this application are true, accurate and complete, and any estimates of emissions reported in this application are based upon reasonable techniques for calculating emissions. I understand that a permit, if granted by the department, cannot be transferred without authorization from the department.</i>	
_____ Signature	_____ Date

APPLICATION INFORMATION

Application Responsible Official Certification

Complete if applying for an initial, revised, or renewal Title V air operation permit or concurrent processing of an air construction permit and revised or renewal Title V air operation permit. If there are multiple responsible officials, the "application responsible official" need not be the "primary responsible official."

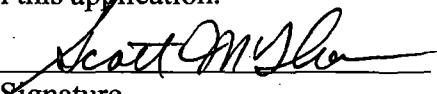
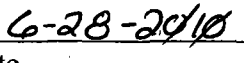
1. Application Responsible Official Name: Scott McIlvaine, Plant Manager
2. Application Responsible Official Qualification (Check one or more of the following options, as applicable): <input checked="" type="checkbox"/> For a corporation, the president, secretary, treasurer, or vice-president of the corporation in charge of a principal business function, or any other person who performs similar policy or decision-making functions for the corporation, or a duly authorized representative of such person if the representative is responsible for the overall operation of one or more manufacturing, production, or operating facilities applying for or subject to a permit under Chapter 62-213, F.A.C. <input type="checkbox"/> For a partnership or sole proprietorship, a general partner or the proprietor, respectively. <input type="checkbox"/> For a municipality, county, state, federal, or other public agency, either a principal executive officer or ranking elected official. <input type="checkbox"/> The designated representative at an Acid Rain source or CAIR source.
3. Application Responsible Official Mailing Address... Organization/Firm: Wheelabrator North Broward, Inc. Street Address: 2600 NW 48th Street City: Pompano Beach State: Florida Zip Code: 33073
4. Application Responsible Official Telephone Numbers... Telephone: (954) 581-6606 ext. Fax: (954) 581-6705
5. Application Responsible Official E-mail Address:
6. Application Responsible Official Certification: I, the undersigned, am a responsible official of the Title V source addressed in this air permit application. I hereby certify, based on information and belief formed after reasonable inquiry, that the statements made in this application are true, accurate and complete and that, to the best of my knowledge, any estimates of emissions reported in this application are based upon reasonable techniques for calculating emissions. The air pollutant emissions units and air pollution control equipment described in this application will be operated and maintained so as to comply with all applicable standards for control of air pollutant emissions found in the statutes of the State of Florida and rules of the Department of Environmental Protection and revisions thereof and all other applicable requirements identified in this application to which the Title V source is subject. I understand that a permit, if granted by the department, cannot be transferred without authorization from the department, and I will promptly notify the department upon sale or legal transfer of the facility or any permitted emissions unit. Finally, I certify that the facility and each emissions unit are in compliance with all applicable requirements to which they are subject, except as identified in compliance plan(s) submitted with this application.  Signature  Date

APPLICATION INFORMATION

Professional Engineer Certification

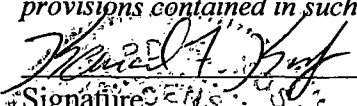
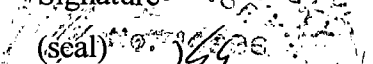
1. Professional Engineer Name: Kennard F. Kosky Registration Number: 14996
2. Professional Engineer Mailing Address... Organization/Firm: Golder Associates Inc.** Street Address: 6026 NW 1st Place City: Gainesville State: FL Zip Code: 32607
3. Professional Engineer Telephone Numbers... Telephone: (352) 336-5600 ext. 21156 Fax: (352) 336-6603
4. Professional Engineer E-mail Address: kkosky@golder.com
5. Professional Engineer Statement: <i>I, the undersigned, hereby certify, except as particularly noted herein*, that:</i> <i>(1) To the best of my knowledge, there is reasonable assurance that the air pollutant emissions unit(s) and the air pollution control equipment described in this application for air permit, when properly operated and maintained, will comply with all applicable standards for control of air pollutant emissions found in the Florida Statutes and rules of the Department of Environmental Protection; and</i> <i>(2) To the best of my knowledge, any emission estimates reported or relied on in this application are true, accurate, and complete and are either based upon reasonable techniques available for calculating emissions or, for emission estimates of hazardous air pollutants not regulated for an emissions unit addressed in this application, based solely upon the materials, information and calculations submitted with this application.</i> <i>(3) If the purpose of this application is to obtain a Title V air operation permit (check here <input checked="" type="checkbox"/> , if so), I further certify that each emissions unit described in this application for air permit, when properly operated and maintained, will comply with the applicable requirements identified in this application to which the unit is subject, except those emissions units for which a compliance plan and schedule is submitted with this application.</i> <i>(4) If the purpose of this application is to obtain an air construction permit (check here <input type="checkbox"/> , if so) or concurrently process and obtain an air construction permit and a Title V air operation permit revision or renewal for one or more proposed new or modified emissions units (check here <input type="checkbox"/> , if so), I further certify that the engineering features of each such emissions unit described in this application have been designed or examined by me or individuals under my direct supervision and found to be in conformity with sound engineering principles applicable to the control of emissions of the air pollutants characterized in this application.</i> <i>(5) If the purpose of this application is to obtain an initial air operation permit or operation permit revision or renewal for one or more newly constructed or modified emissions units (check here <input type="checkbox"/> , if so), I further certify that, with the exception of any changes detailed as part of this application, each such emissions unit has been constructed or modified in substantial accordance with the information given in the corresponding application for air construction permit and with all provisions contained in such permit.</i>  _____ Signature  (seal) <u>6/25/10</u> Date

* Attach any exception to certification statement.

**Board of Professional Engineers Certificate of Authorization #00001670.

II. FACILITY INFORMATION

A. GENERAL FACILITY INFORMATION

Facility Location and Type

1. Facility UTM Coordinates... Zone 17 East (km) 583.541 North (km) 2907.498		2. Facility Latitude/Longitude... Latitude (DD/MM/SS) 26/17/12 Longitude (DD/MM/SS) 80/09/48	
3. Governmental Facility Code: 0	4. Facility Status Code: A	5. Facility Major Group SIC Code: 49	6. Facility SIC(s): 4953
7. Facility Comment :			

Facility Contact

1. Facility Contact Name: Chuck Faller, Environmental Safety and Compliance Director
2. Facility Contact Mailing Address... Organization/Firm: Wheelabrator North Broward, Inc. Street Address: 2600 NW 48th Street City: Pompano Beach State: FL Zip Code: 33073
3. Facility Contact Telephone Numbers: Telephone: (954) 971-8701 ext. Fax: (954) 971-8703
4. Facility Contact E-mail Address: cfaller@wm.com

Facility Primary Responsible Official

Complete if an "application responsible official" is identified in Section I that is not the facility "primary responsible official."

1. Facility Primary Responsible Official Name:
2. Facility Primary Responsible Official Mailing Address... Organization/Firm: Street Address: City: State: Zip Code:
3. Facility Primary Responsible Official Telephone Numbers... Telephone: () ext. Fax: ()
4. Facility Primary Responsible Official E-mail Address:

Facility Regulatory Classifications

Check all that would apply *following* completion of all projects and implementation of all other changes proposed in this application for air permit. Refer to instructions to distinguish between a “major source” and a “synthetic minor source.”

1. <input type="checkbox"/> Small Business Stationary Source	<input type="checkbox"/> Unknown
2. <input type="checkbox"/> Synthetic Non-Title V Source	
3. <input checked="" type="checkbox"/> Title V Source	
4. <input checked="" type="checkbox"/> Major Source of Air Pollutants, Other than Hazardous Air Pollutants (HAPs)	
5. <input type="checkbox"/> Synthetic Minor Source of Air Pollutants, Other than HAPs	
6. <input checked="" type="checkbox"/> Major Source of Hazardous Air Pollutants (HAPs)	
7. <input type="checkbox"/> Synthetic Minor Source of HAPs	
8. <input checked="" type="checkbox"/> One or More Emissions Units Subject to NSPS (40 CFR Part 60)	
9. <input type="checkbox"/> One or More Emissions Units Subject to Emission Guidelines (40 CFR Part 60)	
10. <input checked="" type="checkbox"/> One or More Emissions Units Subject to NESHAP (40 CFR Part 61 or Part 63)	
11. <input type="checkbox"/> Title V Source Solely by EPA Designation (40 CFR 70.3(a)(5))	
12. Facility Regulatory Classifications Comment: MSW Units 1, 2, and 3 are subject to NSPS - 40 CFR 60, Subpart Cb, and NESHAP - 40 CFR 61, Subpart C (for Beryllium)	

List of Pollutants Emitted by Facility

1. Pollutant Emitted	2. Pollutant Classification	3. Emissions Cap [Y or N]?
Particulate Matter Total – PM	A	N
Particulate Matter – PM10	A	N
Sulfur Dioxide – SO2	A	N
Nitrogen Oxides – NOx	A	N
Carbon Monoxide – CO	A	N
Fluoride – FL	A	N
Lead – Pb	B	N
Beryllium – H021	B	N
Cadmium – H027	B	N
Hydrogen Chloride – H106	A	N
Mercury – H114	B	N
Dioxin/Furan – DIOX	B	N

C. FACILITY ADDITIONAL INFORMATION

Additional Requirements for All Applications, Except as Otherwise Stated

- | |
|--|
| 1. Facility Plot Plan: (Required for all permit applications, except Title V air operation permit revision applications if this information was submitted to the department within the previous five years and would not be altered as a result of the revision being sought)
<input checked="" type="checkbox"/> Attached, Document ID: <u>WNB-FI-C1</u> <input type="checkbox"/> Previously Submitted, Date: _____ |
| 2. Process Flow Diagram(s): (Required for all permit applications, except Title V air operation permit revision applications if this information was submitted to the department within the previous five years and would not be altered as a result of the revision being sought)
<input checked="" type="checkbox"/> Attached, Document ID: <u>WNB-FI-C2</u> <input type="checkbox"/> Previously Submitted, Date: _____ |
| 3. Precautions to Prevent Emissions of Unconfined Particulate Matter: (Required for all permit applications, except Title V air operation permit revision applications if this information was submitted to the department within the previous five years and would not be altered as a result of the revision being sought)
<input checked="" type="checkbox"/> Attached, Document ID: <u>WNB-FI-C3</u> <input type="checkbox"/> Previously Submitted, Date: _____ |

Additional Requirements for Air Construction Permit Applications

- | |
|--|
| 1. Area Map Showing Facility Location:
<input type="checkbox"/> Attached, Document ID: _____ <input type="checkbox"/> Not Applicable (existing permitted facility) |
| 2. Description of Proposed Construction, Modification, or Plantwide Applicability Limit (PAL):
<input type="checkbox"/> Attached, Document ID: _____ |
| 3. Rule Applicability Analysis:
<input type="checkbox"/> Attached, Document ID: _____ |
| 4. List of Exempt Emissions Units:
<input type="checkbox"/> Attached, Document ID: _____ <input type="checkbox"/> Not Applicable (no exempt units at facility) |
| 5. Fugitive Emissions Identification:
<input type="checkbox"/> Attached, Document ID: _____ <input type="checkbox"/> Not Applicable |
| 6. Air Quality Analysis (Rule 62-212.400(7), F.A.C.):
<input type="checkbox"/> Attached, Document ID: _____ <input type="checkbox"/> Not Applicable |
| 7. Source Impact Analysis (Rule 62-212.400(5), F.A.C.):
<input type="checkbox"/> Attached, Document ID: _____ <input type="checkbox"/> Not Applicable |
| 8. Air Quality Impact since 1977 (Rule 62-212.400(4)(e), F.A.C.):
<input type="checkbox"/> Attached, Document ID: _____ <input type="checkbox"/> Not Applicable |
| 9. Additional Impact Analyses (Rules 62-212.400(8) and 62-212.500(4)(e), F.A.C.):
<input type="checkbox"/> Attached, Document ID: _____ <input type="checkbox"/> Not Applicable |
| 10. Alternative Analysis Requirement (Rule 62-212.500(4)(g), F.A.C.):
<input type="checkbox"/> Attached, Document ID: _____ <input type="checkbox"/> Not Applicable |

C. FACILITY ADDITIONAL INFORMATION (CONTINUED)

Additional Requirements for FESOP Applications

- | |
|---|
| 1. List of Exempt Emissions Units:
<input type="checkbox"/> Attached, Document ID: _____ <input type="checkbox"/> Not Applicable (no exempt units at facility) |
|---|

Additional Requirements for Title V Air Operation Permit Applications

- | |
|--|
| 1. List of Insignificant Activities: (Required for initial/renewal applications only)
<input checked="" type="checkbox"/> Attached, Document ID: WNB-FI-CV1 <input type="checkbox"/> Not Applicable (revision application) |
|--|

- | |
|--|
| 2. Identification of Applicable Requirements: (Required for initial/renewal applications, and for revision applications if this information would be changed as a result of the revision being sought)
<input checked="" type="checkbox"/> Attached, Document ID: WNB-FI-CV2
<input type="checkbox"/> Not Applicable (revision application with no change in applicable requirements) |
|--|

- | |
|---|
| 3. Compliance Report and Plan: (Required for all initial/revision/renewal applications)
<input checked="" type="checkbox"/> Attached, Document ID: WNB-FI-CV3
Note: A compliance plan must be submitted for each emissions unit that is not in compliance with all applicable requirements at the time of application and/or at any time during application processing. The department must be notified of any changes in compliance status during application processing. |
|---|

- | |
|---|
| 4. List of Equipment/Activities Regulated under Title VI: (If applicable, required for initial/renewal applications only)
<input type="checkbox"/> Attached, Document ID: _____
<input type="checkbox"/> Equipment/Activities Onsite but Not Required to be Individually Listed
<input checked="" type="checkbox"/> Not Applicable |
|---|

- | |
|--|
| 5. Verification of Risk Management Plan Submission to EPA: (If applicable, required for initial/renewal applications only)
<input type="checkbox"/> Attached, Document ID: _____ <input checked="" type="checkbox"/> Not Applicable |
|--|

- | |
|---|
| 6. Requested Changes to Current Title V Air Operation Permit:
<input type="checkbox"/> Attached, Document ID: _____ <input checked="" type="checkbox"/> Not Applicable |
|---|

C. FACILITY ADDITIONAL INFORMATION (CONTINUED)

Additional Requirements for Facilities Subject to Acid Rain, CAIR, or Hg Budget Program

1. Acid Rain Program Forms:

Acid Rain Part Application (DEP Form No. 62-210.900(1)(a):

- Attached, Document ID: _____ Previously Submitted, Date: _____
 Not Applicable (not an Acid Rain source)

Phase II NO_x Averaging Plan (DEP Form No. 62-210.900(1)(a)1.):

- Attached, Document ID: _____ Previously Submitted, Date: _____
 Not Applicable

New Unit Exemption (DEP Form No. 62-210.900(1)(a)2.):

- Attached, Document ID: _____ Previously Submitted, Date: _____
 Not Applicable

2. CAIR Part (DEP Form No. 62-210.900(1)(b)):

- Attached, Document ID: _____ Previously Submitted, Date: _____
 Not Applicable (not a CAIR source)

Additional Requirements Comment

[Empty box for Additional Requirements Comment]

ATTACHMENT WNB-FI-C1
FACILITY PLOT PLAN

48th STREET N.W.

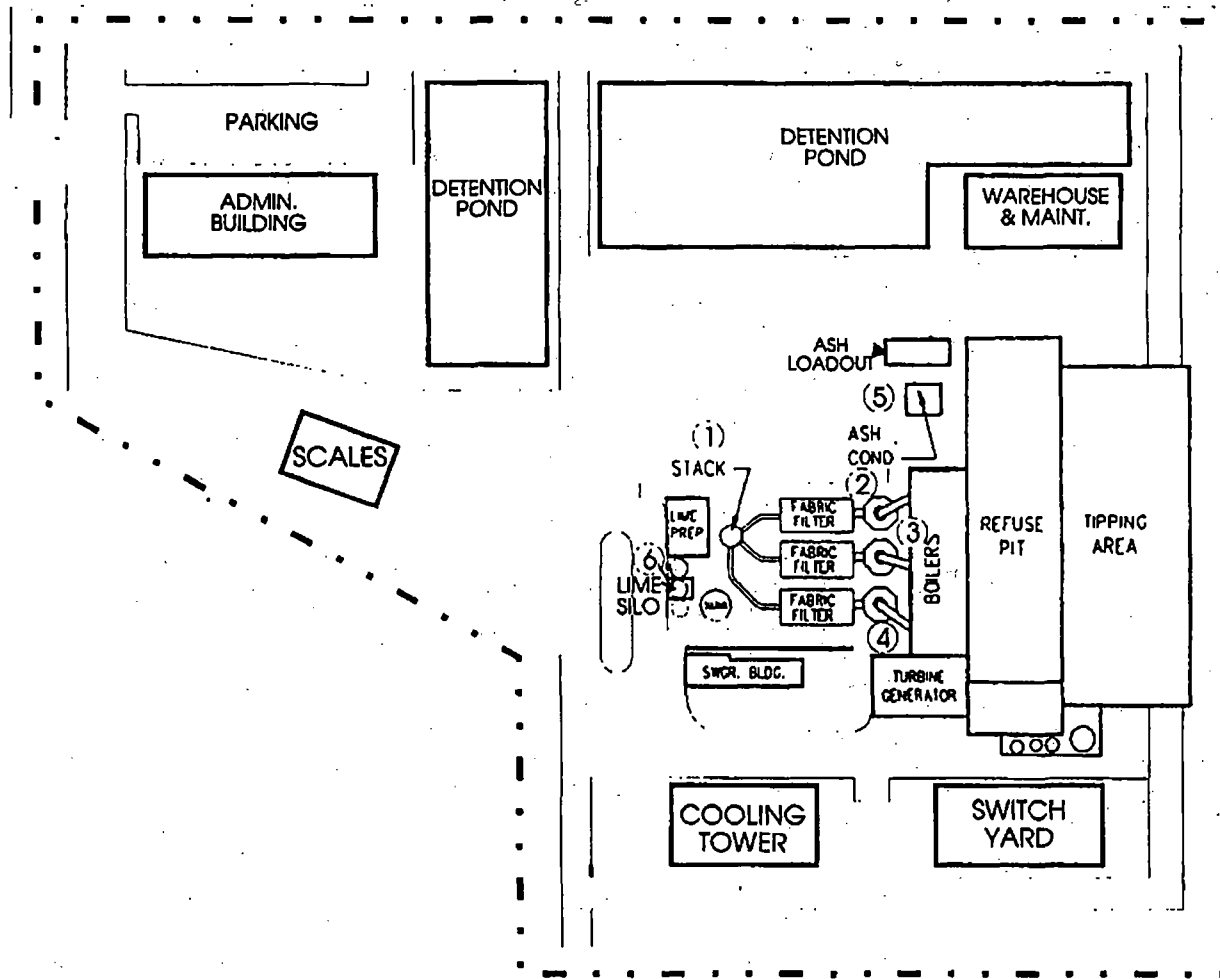

LEGEND

- 1 Stack - 3 Flues (EU001, EU002, EU003)
- 2 Spray Dryer Absorber
- 3 Spray Dryer Absorber
- 4 Spray Dryer Absorber
- 5 Ash Conditioning System (EU005)
- 6 Lime Silo (EU004)



Wheelabrator
 North Broward, Inc.
 Pompano Beach, FL

SITE PLAN

WNB-FI-C1

EXHIBIT F-2

ATTACHMENT WNB-FI-C2
PROCESS FLOW DIAGRAM

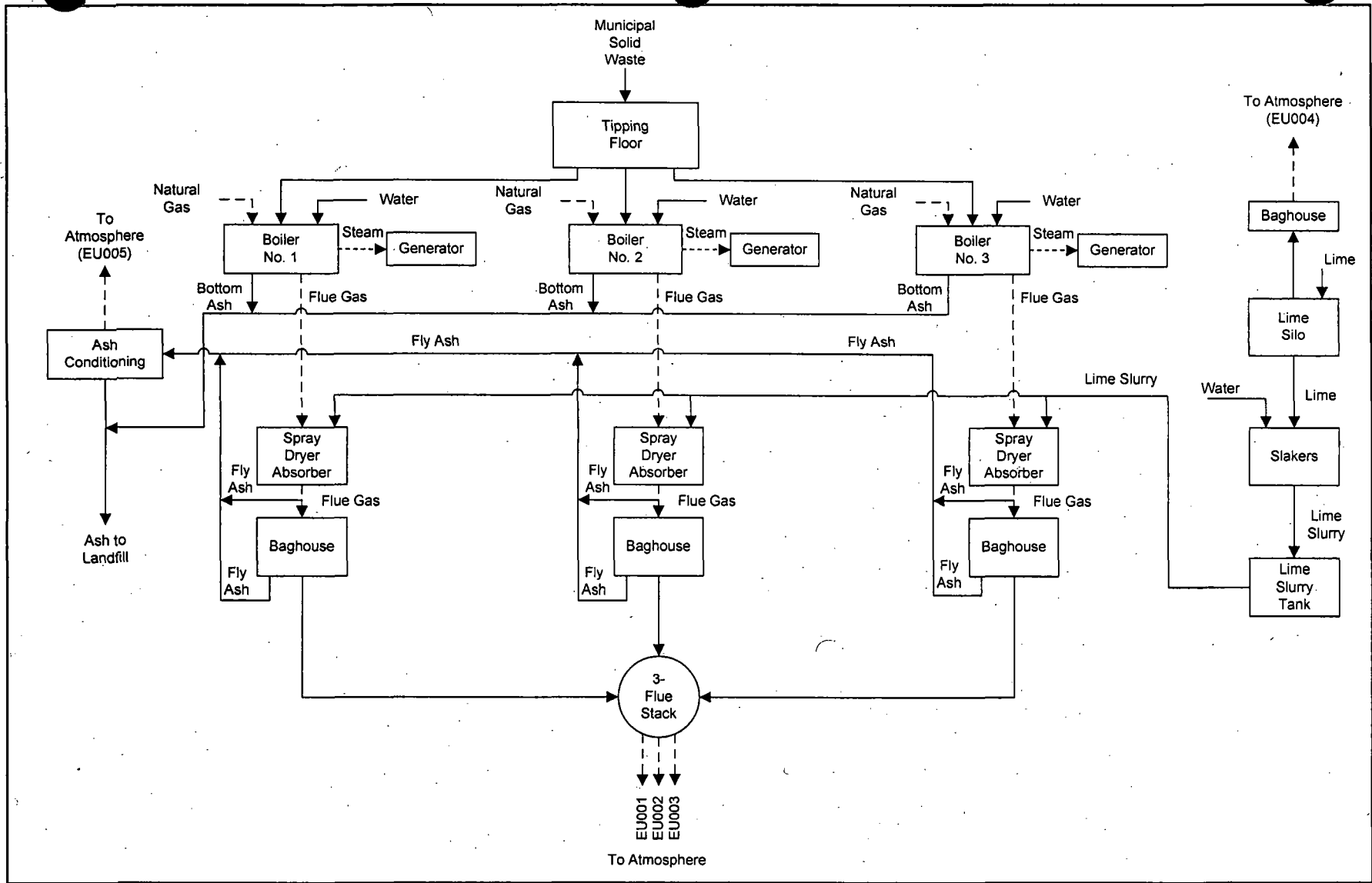

<p>Attachment WNB-FI-C2 Process Flow Diagram, Wheelabrator North Broward Pompano Beach, Florida</p>	<p>Process Flow Legend Solid/Liquid —————> Gas - - - - -> Steam - - - - -></p>	<p>Filename: 103875132-WNB-FI-C2.VSD Date: 06/23/10</p>	 <p>Golder Associates</p>
---	---	--	---

ATTACHMENT WNB-FI-C3

**PRECAUTIONS TO PREVENT EMISSIONS OF
UNCONFINED PARTICULATE MATTER**

**ATTACHMENT WNB-FI-C3
PRECAUTIONS TO PREVENT EMISSIONS OF
OF UNCONFINED PARTICULATE MATTER**

The following reasonable precautions are taken at the facility, pursuant to Rule 62-296.320(4)(c)2, F.A.C., as applicable, to prevent emissions of unconfined particulate matter (PM):

- Chemical or water application to:
 - Unpaved roads
 - Unpaved yard areas
- Paving and maintenance of roads, parking areas, and yards
- Removal of PM from roads and other paved areas under the control of the owner or operator of the facility to prevent re-entrainment, and from buildings or work areas to prevent PM from becoming airborne
- Landscaping or planting of vegetation
- Confining abrasive blasting where possible
- Enclosure or covering of conveyer systems
- Use of hoods, fans, filters, and similar equipment to contain, capture, and/or vent PM

ATTACHMENT WNB-FI-CV1

LIST OF INSIGNIFICANT ACTIVITIES

ATTACHMENT WNB-FI-CV1 LIST OF INSIGNIFICANT ACTIVITIES

A list of existing units and/or activities that are considered to be insignificant and are exempted from Title V permitting under Rule 62-213.430(6), Florida Administrative Code (F.A.C.), is presented below. The exempt activities listed are also those activities that are included in Rule 62-210.300(3)(a), F.A.C., that would not exceed the thresholds in Rule 62-213.430(6)(b)3, F.A.C.

Brief description of emissions units and/or activities:

- Slaker A
- Slaker B
- 3 Chemical Feed Tanks (for Boiler Nos 1-3)
- 2 Cooling Tower Bulk Chemical Tanks
- Cooling Tower
- Non-Halogenated Solvent Degreaser
- Metals Removal System Discharge Chute
- Plant Roads
- Three (3) 500-Gallon Diesel Tanks
- 500-Gallon Gasoline Tank

ATTACHMENT WNB-FI-CV2

IDENTIFICATION OF APPLICABLE REQUIREMENTS

ATTACHMENT WNB-FI-CV2
IDENTIFICATION OF APPLICABLE REQUIREMENTS
TITLE V CORE LIST

Effective: 03/01/02

(Updated based on current version of FDEP Air Rules)

[Note: The Title V Core List is meant to simplify the completion of the "List of Applicable Regulations" for DEP Form No. 62-210.900(1), Application for Air Permit - Long Form. The Title V Core List is a list of rules to which all Title V Sources are presumptively subject. The Title V Core List may be referenced in its entirety, or with specific exceptions. The Department may periodically update the Title V Core List.]

Federal: (description)

40 CFR 61, Subpart M: NESHAP for Asbestos

40 CFR 82: Protection of Stratospheric Ozone

40 CFR 82, Subpart B: Servicing of Motor Vehicle Air Conditioners (MVAC)

40 CFR 82, Subpart F: Recycling and Emissions Reduction

40 CFR 98, Subpart A: Mandatory Reporting of Greenhouse Gases

40 CFR 98, Subpart C: General Stationary Combustion Sources

40 CFR 98, Subpart D: Electricity Generation

State: (description)

CHAPTER 62-4, F.A.C.: PERMITS, effective 03-16-08

62-4.030, F.A.C.: General Prohibition

62-4.040, F.A.C.: Exemptions

62-4.050, F.A.C.: Procedure to Obtain Permits; Application

62-4.060, F.A.C.: Consultation

62-4.070, F.A.C.: Standards for Issuing or Denying Permits; Issuance; Denial

62-4.080, F.A.C.: Modification of Permit Conditions

62-4.090, F.A.C.: Renewals

62-4.100, F.A.C.: Suspension and Revocation

62-4.110, F.A.C.: Financial Responsibility

62-4.120, F.A.C.: Transfer of Permits

62-4.130, F.A.C.: Transferability of Definitions

62-4.150, F.A.C.: Review

62-4.160, F.A.C.: Permit Conditions

62-4.210, F.A.C.: Construction Permits

62-4.220, F.A.C.: Operation Permit for New Sources

CHAPTER 62-210, F.A.C.: STATIONARY SOURCES - GENERAL REQUIREMENTS, effective 06-29-09

62-210.300, F.A.C.: Permits Required

62-210.300(1), F.A.C.: Air Construction Permits

62-210.300(2), F.A.C.: Air Operation Permits

62-210.300(3), F.A.C.: Exemptions

62-210.300(5), F.A.C.: Notification of Startup

62-210.300(6), F.A.C.: Emissions Unit Reclassification

62-210.300(7), F.A.C.: Transfer of Air Permits

62-210.350, F.A.C.: Public Notice and Comment

62-210.350(1), F.A.C.: Public Notice of Proposed Agency Action

62-210.350(2), F.A.C.: Additional Public Notice Requirements for Emissions Units Subject to Prevention of Significant Deterioration or Nonattainment-Area Preconstruction Review

62-210.350(3), F.A.C.: Additional Public Notice Requirements for Sources Subject to Operation Permits for Title V Sources

62-210.360, F.A.C.: Administrative Permit Corrections

62-210.370, F.A.C.: Emissions Computation and Reporting

62-210.400, F.A.C.: Emission Estimates

62-210.650, F.A.C.: Circumvention

62-210.700, F.A.C.: Excess Emissions

62-210.900, F.A.C.: Forms and Instructions

62-210.900(1), F.A.C.: Application for Air Permit – Title V Source, Form and Instructions

62-210.900(5), F.A.C.: Annual Operating Report for Air Pollutant Emitting Facility, Form and Instructions

62-210.900(7), F.A.C.: Application for Transfer of Air Permit – Title V and Non-Title V Source

CHAPTER 62-212, F.A.C.: STATIONARY SOURCES - PRECONSTRUCTION REVIEW, effective 06-29-09

CHAPTER 62-213, F.A.C.: OPERATION PERMITS FOR MAJOR SOURCES OF AIR POLLUTION, effective 10-12-08

62-213.205, F.A.C.: Annual Emissions Fee

62-213.400, F.A.C.: Permits and Permit Revisions Required

62-213.410, F.A.C.: Changes Without Permit Revision

62-213.412, F.A.C.: Immediate Implementation Pending Revision Process

62-213.415, F.A.C.: Trading of Emissions Within a Source

62-213.420, F.A.C.: Permit Applications

62-213.430, F.A.C.: Permit Issuance, Renewal, and Revision

62-213.440, F.A.C.: Permit Content

62-213.450, F.A.C.: Permit Review by EPA and Affected States

62-213.460, F.A.C.: Permit Shield

62-213.900, F.A.C.: Forms and Instructions

62-213.900(1), F.A.C.: Major Air Pollution Source Annual Emissions Fee Form

62-213.900(7), F.A.C.: Statement of Compliance Form

CHAPTER 62-296, F.A.C.: STATIONARY SOURCES - EMISSION STANDARDS, effective 10-06-08

62-296.320(4)(c), F.A.C.: Unconfined Emissions of Particulate Matter

62-296.320(2), F.A.C.: Objectionable Odor Prohibited

CHAPTER 62-297, F.A.C.: STATIONARY SOURCES - EMISSIONS MONITORING, effective 2-12-04

62-297.310, F.A.C.: General Test Requirements

62-297.310(4), F.A.C.: Applicable Test Procedures

62-297.310(7), F.A.C.: Frequency of Compliance Tests

62-297.310(6), F.A.C.: Repaired Stack Sampling Facilities

62-297.310(5), F.A.C.: Determination of Process Variables

62-297.510(8), F.A.C.: Test Report

62-297.620, F.A.C.: Exceptions and Approval of Alternate Procedures and Requirements

Miscellaneous:

CHAPTER 28-106, F.A.C.: Decisions Determining Substantial Interests

CHAPTER 62-110, F.A.C.: Exception to the Uniform Rules of Procedure, effective 07-01-98

CHAPTER 62-256, F.A.C.: Open Burning and Frost Protection Fires, effective 10-06-08

CHAPTER 62-257, F.A.C.: Asbestos Notification and Fee, effective 10-12-08

CHAPTER 62-281, F.A.C.: Motor Vehicle Air Conditioning Refrigerant Recovery and Recycling, effective 09-10-96

ATTACHMENT WNB-FI-CV3
COMPLIANCE REPORT AND PLAN



Wheelabrator North Broward Inc.

A Waste Management Company

2600 Wiles Road
Pompano Beach, FL 33073
(954) 971-8701 Tel
(954) 971-8703 Fax

April 1, 2010

CERTIFIED MAIL #70080500000147115472

Mr. Lennon Anderson
Air Program Administrator
Florida Department of Environmental Protection
Southeast District
400 North Congress Ave., Suite 200
West Palm Beach, FL 33401

Re: Wheelabrator North Broward
Title V Annual Statement of Compliance, 2009

Dear Mr. Anderson:

As requested by the Department, please find attached a revised copy of the 2009 Wheelabrator North Broward Title V Annual Statement of Compliance. The original Statement of Compliance was submitted to your office on February 3, 2010. As requested, this revised Statement includes attachments detailing all incidents of allowable excluded data from start up, shut down and malfunction events, which became effective with rules changes that went into affect on April 29, 2009.

It is Wheelabrator's understanding the Department will be reviewing the annual Title V certification with regards to implementation of the May, 2006 revisions to the large municipal waste combustor NSPS requirements and advising us of any future changes in reporting requirements.

I, the undersigned, am a responsible official, as defined in Rule 62-210.200, F.A.C., of the Title V source addressed in this submittal. I hereby certify, based on information and belief formed after reasonable inquiry, that the statements and information in this document are true, accurate and complete.

If there are any questions, please contact this office at (954) 971-8701.

Sincerely,

Scott McIlvaine
Plant Manager

Cc: Rosalyn Hughes – USEPA – Region IV – CERTIFIED MAIL (with) #70080500000147118046
Patricia Tampas – FDEP – WP Beach (without)
Chuck Faller (with)
Tim Porter (with)
Rob French – MPI (with)
Ram Tewari – BCWRS (without)





Department of Environmental Protection

Division of Air Resource Management

STATEMENT OF COMPLIANCE - TITLE V SOURCE

REASON FOR SUBMISSION (Check one to indicate why this statement of compliance is being submitted)

Annual Requirement Transfer of Permit Permanent Facility Shutdown

REPORTING PERIOD*	REPORT DEADLINE**
JANUARY 1 through DECEMBER 31 of 2009 (year)	FEBRUARY 28, 2010

*The statement of compliance must cover all conditions that were in effect during the indicated reporting period, including any conditions that were added, deleted, or changed through permit revision.

**See Rule 62-213.440(3)(a)2., F.A.C.

Facility Owner/Company Name: WHEELABRATOR NORTH BROWARD

Site Name: WHEELABRATOR NORTH BROWARD Facility ID No. 0112120 County: BROWARD

COMPLIANCE STATEMENT (Check only one of the following three options)

A. This facility was in compliance with all terms and conditions of the Title V Air Operation Permit and, if applicable, the Acid Rain Part, and there were no reportable incidents of deviations from applicable requirements associated with any malfunction or breakdown of process, fuel burning or emission control equipment, or monitoring systems during the reporting period identified above.

B. This facility was in compliance with all terms and conditions of the Title V Air Operation Permit and, if applicable, the Acid Rain Part; however, there were one or more reportable incidents of deviations from applicable requirements associated with malfunctions or breakdowns of process, fuel burning or emission control equipment, or monitoring systems during the reporting period identified above, which were reported to the Department. For each incident of deviation, the following information is included:

1. Date of report previously submitted identifying the incident of deviation.
2. Description of the incident.

C. This facility was in compliance with all terms and conditions of the Title V Air Operation Permit and, if applicable, the Acid Rain Part, EXCEPT those identified in the pages attached to this report and any reportable incidents of deviations from applicable requirements associated with malfunctions or breakdowns of process, fuel burning or emission control equipment, or monitoring systems during the reporting period identified above, which were reported to the Department. For each item of noncompliance, the following information is included:

1. Emissions unit identification number.
2. Specific permit condition number (note whether the permit condition has been added, deleted, or changed during certification period).
3. Description of the requirement of the permit condition.
4. Basis for the determination of noncompliance (for monitored parameters, indicate whether monitoring was continuous, i.e., recorded at least every 15 minutes, or intermittent).
5. Beginning and ending dates of periods of noncompliance.
6. Identification of the probable cause of noncompliance and description of corrective action or preventative measures implemented.
7. Dates of any reports previously submitted identifying this incident of noncompliance.

For each incident of deviation, as described in paragraph B. above, the following information is included:

1. Date of report previously submitted identifying the incident of deviation.
2. Description of the incident.

STATEMENT OF COMPLIANCE - TITLE V SOURCE

RESPONSIBLE OFFICIAL CERTIFICATION

I, the undersigned, am a responsible official (Title V air permit application or responsible official notification form on file with the Department) of the Title V source for which this document is being submitted. With respect to all matters other than Acid Rain program requirements, I hereby certify, based on the information and belief formed after reasonable inquiry, that the statements made and data contained in this document are true, accurate, and complete.

Scott M. McIlvaine
(Signature of Title V Source Responsible Official)

4-1-10
(Date)

Name: SCOTT MCILVAINE

Title: PLANT MANAGER

DESIGNATED REPRESENTATIVE CERTIFICATION (only applicable to Acid Rain source)

I, the undersigned, am authorized to make this submission on behalf of the owners and operators of the Acid Rain source or Acid Rain units for which the submission is made. I certify under penalty of law that I have personally examined, and am familiar with, the statements and information submitted in this document and all its attachments. Based on my inquiry of those individuals with primary responsibility for obtaining the information, I certify that the statements and information are to the best of my knowledge and belief true, accurate, and complete. I am aware that there are significant penalties for submitting false statements and information or omitting required statements and information, including the possibility of fine or imprisonment.

(Signature of Acid Rain Source Designated Representative)

(Date)

Name: _____

Title: _____

{Note: Attachments, if required, are created by a responsible official or designated representative, as appropriate, and should consist of the information specified and any supporting records. Additional information may also be attached by a responsible official or designated representative when elaboration is required for clarity. This report is to be submitted to both the compliance authority (DEP district or local air program) and the U.S. Environmental Protection Agency (EPA) (U.S. EPA Region 4, Air and EPCRA Enforcement Branch, 61 Forsyth Street, Atlanta GA 30303).}

**WHEELABRATOR NORTH BROWARD
STATEMENT OF COMPLIANCE – TITLE V SOURCE
INCIDENTS OF DEVIATION
REPORTING PERIOD: 01/01/09 THROUGH 12/31/09**

Please see attached quarterly and semi-annual reports that include, or reference, incidents of allowable excluded data due to start up, shut down or malfunction.

Unit #3:

Date reported: 4/2/09

Description: On 2/25/09 while unit 1 was on gas and unit 2 was off line for FP&L switchyard maintenance, the emergency relief valve stuck, tripping the turbine/generator and boiler which resulted in the CO 4-hr block average from 0800-1200 hrs exceeding the facility permit limit. Facility personnel shut the boiler off line until FP&L maintenance was completed. The unit was brought off line at 1057 hrs.

Wheelabrator North Broward Quarterly Excess Emission Report

Reporting Period:
 From: 1/1/2009
 To: 3/31/2009

40 CFR 60.59b(h) - Exceedences of Applicable Limits

Unit	Date	Emission or Parameter	Block Average Duration	Limit Averaging Time	Magnitude	Limit	Units	60.7 Excess Emission Category	Reason	Corrective Action	Actual Duration of Operation
3	2/25/2009	CO	0800-1200	4-hr block	178	100	ppm @ 7% O2	Shutdown	While Unit 1 was on gas & Unit 2 was off line for FP&L switchyard maintenance, emergency relief valve stuck tripping boiler #3 and turbine	Shut down boiler until FP&L maintenance was complete and utility power restored; unit off line at 1057 hrs	2.9 hrs

Unit: 1, 2 or 3

Emission or Parameter: CO, NOx, SO2, Opacity, Steam Flow or FF Inlet Temperature

Block Average Duration : CEMS time used to identify excess emission event

Limit Averaging Time: 6-minute (opacity), 4-hr block (CO, Steam Flow or FF Inlet Temp), 24-hour block (SO2 or NOx)

Magnitude: Recorded value for excess emission event

Limit: facility permit limit

Units: kbs/hr (steam flow), ppm @ 7% O2 (CO, SO2 or NOx) , % (opacity), Deg F (FF Inlet Temperature)

60.7 Excess Emission Category: Startup/Shutdown, control equipment problems (malfunctions), process problems (malfunctions), Other Known, Unknown

Actual Duration of Operation: Total duration of excess emission related to boiler online time, i.e. if boiler online for only 3 hours in 4 hr block average then duration only 3 hours-otherwise duration = limit averaging time.

There were no exceedences for NOx, SO2, opacity, fabric filter inlet temperature or steam flow.

Reporting Period:
4/1/2009
To: 6/30/2009

Excluded Hourly Averages During Startup/Shutdown/Malfunction Events (after 4/29/09)

Unit	Date	Emission or Parameter	Period of Excluded Data	Excluded Data Average	Units	60.7 Excess Emission Category (Reason for Excluding Data)	Reason for Excess Emission	Excess Emission Corrective Action	Total Time Excluded (Hours)
2	5/21/2009	CO	1000-1059	443	ppm @ 7% O2	Process problems (malfunction)	Turbine/generator trip due to low vacuum caused by cooling tower circ pump #2 blowing up, tripping 5 KV breaker (possible lightning strike); T/G trip caused boiler fans to trip causing boiler upset condition	Restarted cooling tower recirc pumps (1 & 3); reset 5 KV breaker; raised boiler master to 100K; started gas guns; restarted boiler fans	1.0
3	5/21/2009	CO	1000-1059	1737	ppm @ 7% O2	Process problems (malfunction)	Turbine/generator trip due to low vacuum caused by cooling tower circ pump #2 blowing up, tripping 5 KV breaker (possible lightning strike); T/G trip caused boiler fans to trip causing boiler upset condition	Restarted cooling tower recirc pumps (1 & 3); reset 5 KV breaker; raised boiler master to 100K; started gas guns; restarted boiler fans	1.0
1	5/27/2009	CO	2200-2359	180	ppm @ 7% O2	Process problems (malfunction)	Combustion control malfunction; oversteaming after wet trash even; O2 dropping out	Lowered secondary air; adjusted primary air; placed O2 trim control at 50%	2.0
Total Hours Excluded									4.0

Emission or Parameter: CO, NOx, SO2, Opacity, Steam Flow, or FF Inlet Temperature

Units: kbs/hr (steam flow), ppm @ 7% O2 (CO, SO2 or NOx), % (opacity), Deg F (FF Inlet Temperature)

60.7 Excess Emission Category: Startup/Shutdown, control equipment problems (malfunctions), process problems (malfunctions), Other Known, Unknown

There were no permit exceedances for CO, NOx, SO2, steam flow or FF inlet temperature other than the allowable start up/shut down/malfunction events listed above

Reporting Period:
 From: 7/1/2009
 To: 9/30/2009

Excluded Hourly Averages During Startup/Shutdown/Malfunction Events (after 4/28/08)

Unit	Date	Emission or Parameter	Period of Excluded Data	Excluded Data Average	Units	60.7 Excess Emission Category (Reason for Excluding Data)	Reason for Excess Emission	Excess Emission Corrective Action	Total Time Excluded (Hours)
1	8/13/2009	CO	0800-0859 & 1000-1159	203	ppm @ 7% O2	process problems (malfunction)	Grate module 1-3 out of service due to a broken carriage resulted in a boiler upset condition during a wet trash/low pit inventory event; gas guns and steam coil air heaters already in service	Adjusted primary and secondary air to boiler; reduced boiler load; changed area of the pit feeding the boiler; grate module repaired during September 27 outage	3.0
2	9/21/2009	CO	0400-0459	348	ppm @ 7% O2	control equipment problems (malfunction)	Gas burners tripped during a wet trash event	cleared clinkers and fire eyes cleaned on guns 3 & 4; tightened carriage bolts and straightened ignitor rod on gun 1; cleared clinker on gun 2 fire eye	1.0

Total Hours Excluded 4.0

Emission or Parameter: CO, NOx, SO2, Opacity, Steam Flow, or FF Inlet Temperature

Units: kbs/hr (steam flow), ppm @ 7% O2 (CO, SO2 or NOx), % (opacity), Deg F (FF Inlet Temperature)

60.7 Excess Emission Category: Startup/Shutdown, control equipment problems (malfunctions), process problems (malfunctions), Other Known, Unknown

There were no permit exceedances for CO, NOx, SO2, steam flow or FF Inlet temperature other than the allowable start up/shut down/malfunction events listed above

Reporting Period:
 From: 10/1/2009
 To: 12/31/2009

Excluded Hourly Averages During Startup/Shutdown/Malfunction Events (after 4/28/09)

Unit	Date	Emission or Parameter	Period of Excluded Data	Excluded Data Average	Units	60.7 Excess Emission Category (Reason For Exceeding Data)	Reason for Excess Emission	Excess Emission/Corrective Action	Total Time Excluded (Hours)
2	10/1/2009	SO2	0500-0759	57	ppm @ 7% O2	Start up/Shut down	Start up after scheduled outage followed by immediate shut down due to boiler tube rupture; boiler on line at 0422 hrs and off line at 0810 hrs	Continue with start up and subsequent shut down	3.0
2	12/21/2009	CO	1400-1459	297	ppm @ 7% O2	Process problems (malfunction)	Gas burners failed to ignite during a wet trash event; gas guns were tried twice before they ignited	Checked gas guns for clinkers; cleaned gas gun fire eyes; adjusted primary air; took out secondary air; slowed grates, lowered load; steam coil air heaters already in service	1.0
Total Hours Excluded									4.0

Emission or Parameter: CO, NOx, SO2, Opacity, Steam Flow, or FF Inlet Temperature

Units: kbs/hr (steam flow), ppm @ 7% O2 (CO, SO2 or NOx), % (opacity), Deg F (FF Inlet Temperature)

60.7 Excess Emission Category: Startup/Shutdown, control equipment problems (malfunctions), process problems (malfunctions), Other Known, Unknown

There were no permit exceedances for CO, NOx, SO2, steam flow or FF inlet temperature other than the allowable start up/shut down/malfunction events listed above

Wheelabrator North Broward Title V Appendix TV-6 Condition 43 Deviation Report and
 Subpart Cb Semiannual Report (40 CFR 60.59b(h))

Reporting Period:
 From: 1/1/2009
 To: 6/30/2009

Exceedances of Title V and Subpart Cb Applicable Limits

Unit	Date	Emission or Parameter	Block Average Duration	Limit Averaging Time	Magnitude	Limit	Units	60.7 Excess Emission Category	Reason	Corrective Action	Duration of Excess Emission
3	2/25/2009	CO	0800-1200	4-hr block	178	100	ppm @ 7% O ₂	Shut down	While Unit 1 was on gas & Unit 2 was off line for FP&L switchyard maintenance, emergency relief valve stuck, tripping boiler #3 and turbine	Shut down boiler until FP&L maintenance was complete and utility power restored; unit off line at 1057 hrs	2.9 hrs

There were no exceedances for NO_x, SO₂, opacity, fabric filter inlet temperature, or steam flow.

Please refer to quarterly excess emission/excluded data reports for detailed listing of excluded data events.

There were no other deviations from Title V conditions during this period.

Emission or Parameter: CO, NO_x, SO₂, Opacity, Steam Flow or FF Inlet Temperature

Block Average Duration: CEMS time used to identify excess emission event

Limit Averaging Time: 6-minute (opacity), 4-hr block (CO, Steam Flow or FF Inlet Temp), 24-hour block (SO₂ or NO_x)

Magnitude: Recorded value for excess emission event

Limit: facility permit limit

Units: kbs/hr (steam flow), ppm @ 7% O₂ (CO, SO₂ or NO_x), % (opacity), Deg F (FF Inlet Temperature)

60.7 Excess Emission Category: Startup/Shutdown, control equipment problems (malfunctions), process problems (malfunctions), Other Known, Unknown

Actual Duration: Total duration of excess emission related to boiler online time, i.e. if boiler online for only 3 hours in 4 hr block average then duration only 3 hours-otherwise duration = limit averaging time.

Wheelabrator North Broward Title V Appendix TV-6 Condition 43 Deviation Report and Subpart Cb Semiannual Report (40 CFR 60.59b(h))

From: 7/1/2009
To: 12/31/2009

Exceedences of Title V and Subpart Cb Applicable Limits

Unit	Date	Emission or Parameter	Block Average Duration	Limit Averaging Time	Magnitude	Shift	Units	60.7 Excess Emission Category	Reason	Corrective Action	Duration of Excess Emission

There were no exceedences for CO, NOx, SO2, opacity, fabric filter inlet temperature, or steam flow.

Please refer to quarterly excess emission/excluded data reports for detailed listing of excluded data events.

There were no other deviations from Title V conditions during this period.

Emission or Parameter: CO, NOx, SO2, Opacity, Steam Flow or FF Inlet Temperature

Block Average Duration : CEMS time used to identify excess emission event

Limit Averaging Time: 6-minute (opacity), 4-hr block (CO, Steam Flow or FF Inlet Temp), 24-hour block (SO2 or NOx)

Magnitude: Recorded value for excess emission event

Limit: facility permit limit

Units: kbs/hr (steam flow), ppm @ 7% O2 (CO, SO2 or NOx) , % (opacity), Deg F (FF Inlet Temperature)

60.7 Excess Emission Category: Startup/Shutdown, control equipment problems (malfunctions), process problems (malfunctions), Other Known, Unknown

Actual Duration: Total duration of excess emission related to boiler online time, i.e. if boiler online for only 3 hours in 4 hr block average then duration only 3 hours-otherwise duration = limit averaging time.

EMISSIONS UNIT INFORMATION

Section [1]

MSW Combustor & Auxiliary Burners: Units 1, 2, and 3

III. EMISSIONS UNIT INFORMATION

Title V Air Operation Permit Application - For Title V air operation permitting only, emissions units are classified as regulated, unregulated, or insignificant. If this is an application for an initial, revised or renewal Title V air operation permit, a separate Emissions Unit Information Section (including subsections A through I as required) must be completed for each regulated and unregulated emissions unit addressed in this application. Some of the subsections comprising the Emissions Unit Information Section of the form are optional for unregulated emissions units. Each such subsection is appropriately marked. Insignificant emissions units are required to be listed at Section II, Subsection C.

Air Construction Permit or FESOP Application - For air construction permitting or federally enforceable state air operation permitting, emissions units are classified as either subject to air permitting or exempt from air permitting. The concept of an "unregulated emissions unit" does not apply. If this is an application for an air construction permit or FESOP, a separate Emissions Unit Information Section (including subsections A through I as required) must be completed for each emissions unit subject to air permitting addressed in this application for air permit. Emissions units exempt from air permitting are required to be listed at Section II, Subsection C.

Air Construction Permit and Revised/Renewal Title V Air Operation Permit Application - Where this application is used to apply for both an air construction permit and a revised or renewal Title V air operation permit, each emissions unit is classified as either subject to air permitting or exempt from air permitting for air construction permitting purposes, and as regulated, unregulated, or insignificant for Title V air operation permitting purposes. A separate Emissions Unit Information Section (including subsections A through I as required) must be completed for each emissions unit addressed in this application that is subject to air construction permitting and for each such emissions unit that is a regulated or unregulated unit for purposes of Title V permitting. (An emissions unit may be exempt from air construction permitting but still be classified as an unregulated unit for Title V purposes.) Emissions units classified as insignificant for Title V purposes are required to be listed at Section II, Subsection C.

If submitting the application form in hard copy, the number of this Emissions Unit Information Section and the total number of Emissions Unit Information Sections submitted as part of this application must be indicated in the space provided at the top of each page.

EMISSIONS UNIT INFORMATION

Section [1]

MSW Combustor & Auxiliary Burners: Units 1, 2, and 3

A. GENERAL EMISSIONS UNIT INFORMATION

Title V Air Operation Permit Emissions Unit Classification

1. Regulated or Unregulated Emissions Unit? (Check one, if applying for an initial, revised or renewal Title V air operation permit. Skip this item if applying for an air construction permit or FESOP only.)
- The emissions unit addressed in this Emissions Unit Information Section is a regulated emissions unit.
- The emissions unit addressed in this Emissions Unit Information Section is an unregulated emissions unit.

Emissions Unit Description and Status

1. Type of Emissions Unit Addressed in this Section: (Check one)
- This Emissions Unit Information Section addresses, as a single emissions unit, a single process or production unit, or activity, which produces one or more air pollutants and which has at least one definable emission point (stack or vent).
- This Emissions Unit Information Section addresses, as a single emissions unit, a group of process or production units and activities which has at least one definable emission point (stack or vent) but may also produce fugitive emissions.
- This Emissions Unit Information Section addresses, as a single emissions unit, one or more process or production units and activities which produce fugitive emissions only.

2. Description of Emissions Unit Addressed in this Section:

Three (3) 807-tons per day (TPD) Municipal Solid Waste (MSW) Combustors & Auxiliary Burners.

3. Emissions Unit Identification Number: **001, 002, and 003**

4. Emissions Unit Status Code: A	5. Commence Construction Date: 	6. Initial Startup Date: 6/13, 6/23, and 7/31/1991	7. Emissions Unit Major Group SIC Code: 49
--	--	--	--

8. Federal Program Applicability: (Check all that apply)
- Acid Rain Unit
- CAIR Unit

9. Package Unit:
Manufacturer: **Babcock and Wilcox** Model Number:

10. Generator Nameplate Rating: **67.6 MW**

11. Emissions Unit Comment:

Generator nameplate rating of 67.6 MW is the facility total. All three units share a common stack containing one flue for each unit.

EMISSIONS UNIT INFORMATION

Section [1]

MSW Combustor & Auxiliary Burners: Units 1, 2, and 3

Emissions Unit Control Equipment/Method: Control 1 of 4

1. Control Equipment/Method Description:

Spray Dryer Absorber

2. Control Device or Method Code: **202**

Emissions Unit Control Equipment/Method: Control 2 of 4

1. Control Equipment/Method Description:

Fabric Filter High-Temperature [T > 250 degrees Fahrenheit (°F)]

2. Control Device or Method Code: **016**

Emissions Unit Control Equipment/Method: Control 3 of 4

1. Control Equipment/Method Description:

Selective Non-Catalytic Reduction for NO_x control

2. Control Device or Method Code: **107**

Emissions Unit Control Equipment/Method: Control 4 of 4

1. Control Equipment/Method Description:

Control of Percent Oxygen (O₂) in Combustion Air (Off-Stoichiometric Firing) for CO control (Good Combustion Control)

2. Control Device or Method Code: **033**

Emissions Unit Control Equipment/Method: Control of

1. Control Equipment/Method Description:

2. Control Device or Method Code:

EMISSIONS UNIT INFORMATION

Section [1]

MSW Combustor & Auxiliary Burners: Units 1, 2, and 3

C. EMISSION POINT (STACK/VENT) INFORMATION

(Optional for unregulated emissions units.)

Emission Point Description and Type

1. Identification of Point on Plot Plan or Flow Diagram: 1 – Stack		2. Emission Point Type Code: 1	
3. Descriptions of Emission Points Comprising this Emissions Unit for VE Tracking:			
4. ID Numbers or Descriptions of Emission Units with this Emission Point in Common:			
5. Discharge Type Code:	6. Stack Height: 195 feet	7. Exit Diameter: 7.5 Feet	
8. Exit Temperature: 300°F	9. Actual Volumetric Flow Rate: 169,000 acfm	10. Water Vapor: %	
11. Maximum Dry Standard Flow Rate: 80,000 dscfm		12. Nonstack Emission Point Height: Feet	
13. Emission Point UTM Coordinates... Zone: 17 East (km): 583.891 North (km): 2907.777		14. Emission Point Latitude/Longitude... Latitude (DD/MM/SS) 26/17/14 Longitude (DD/MM/SS) 80/09/35	
15. Emission Point Comment: There is one common stack containing one flue for each of the three MSW combustors. Stack parameters are average values for each flue. Stack parameters based on Title V permit application dated April 2005.			

EMISSIONS UNIT INFORMATION

Section [1]

MSW Combustor & Auxiliary Burners: Units 1, 2, and 3

D. SEGMENT (PROCESS/FUEL) INFORMATION

Segment Description and Rate: Segment 1 of 5

1. Segment Description (Process/Fuel Type): External Combustion Boilers; Electrical Generation; Natural Gas; Boilers > 100 Million Btu/hr except Tangential		
2. Source Classification Code (SCC): 1-01-006-01		3. SCC Units: Million Cubic Feet Natural Gas Burned
4. Maximum Hourly Rate: 0.89	5. Maximum Annual Rate: 779.38	6. Estimated Annual Activity Factor: 10%
7. Maximum % Sulfur:	8. Maximum % Ash:	9. Million Btu per SCC Unit: 1,020
10. Segment Comment: Fuel used for auxiliary burners. Used as fuel during warm-up, startup, shutdown, and malfunctions, as well as other times when necessary and consistent with good combustion practice. Maximum hourly firing rate based on 907.5 MMBtu/hr heat input per the three units. Maximum annual firing rate based on annual activity factor of 10% operation during the year (876 hr/yr).		

Segment Description and Rate: Segment 2 of 5

1. Segment Description (Process/Fuel Type): External Combustion Boilers; Electrical Generation; Solid Waste; Municipal Solid Waste.		
2. Source Classification Code (SCC): 1-01-012-01		3. SCC Units: Tons Solid Waste Burned
4. Maximum Hourly Rate: 100.83	5. Maximum Annual Rate: 883,300	6. Estimated Annual Activity Factor:
7. Maximum % Sulfur: 0.2	8. Maximum % Ash: 30	9. Million Btu per SCC Unit: 9
10. Segment Comment: MSW throughput limited to 807 TPD per unit (2,420 TPD total), and 907.5 MMBtu/hr for all three units as determined on a monthly average. Maximum annual rate based on the three units operating for 365 days/yr.		

EMISSIONS UNIT INFORMATION

Section [1]

MSW Combustor & Auxiliary Burners: Units 1, 2, and 3

D. SEGMENT (PROCESS/FUEL) INFORMATION

Segment Description and Rate: Segment 3 of 5

1. Segment Description (Process/Fuel Type): External Combustion Boilers; Electrical Generation; Distillate Oil; Grades 1 and 2 Oil		
2. Source Classification Code (SCC): 1-01-005-01		3. SCC Units: 1,000 Gallons
4. Maximum Hourly Rate: 6.48	5. Maximum Annual Rate: 5,676.5	6. Estimated Annual Activity Factor: 10%
7. Maximum % Sulfur: 0.3	8. Maximum % Ash:	9. Million Btu per SCC Unit: 140
10. Segment Comment: Alternative fuel for startup burners. Maximum hourly firing rate based on 907.5 MMBtu/hr heat input per the three units. Maximum annual firing rate based on annual activity factor of 10% operation during the year (876 hr/yr).		

Segment Description and Rate: Segment 4 of 5

1. Segment Description (Process/Fuel Type): External Combustion Boilers; Electrical Generation; Solid Waste; Tires		
2. Source Classification Code (SCC): 1-01-012-01		3. SCC Units:
4. Maximum Hourly Rate: 3.03	5. Maximum Annual Rate: 26,499	6. Estimated Annual Activity Factor: Tons of tires burned
7. Maximum % Sulfur:	8. Maximum % Ash:	9. Million Btu per SCC Unit:
10. Segment Comment: The total quantity of waste tires received as segregated loads and burned at the facility limited to 3%, by weight, of the facility's total fuel. Maximum hourly rate: 0.03 x 2,420 TPD x (day/24 hr) = 3.025 tons/hr Maximum annual rate: 0.03 x 2,420 TPD x (365/yr) = 26,499 tons/hr		

EMISSIONS UNIT INFORMATION

Section [1]

MSW Combustor & Auxiliary Burners: Units 1, 2, and 3

D. SEGMENT (PROCESS/FUEL) INFORMATION

Segment Description and Rate: Segment 5 of 5

1. Segment Description (Process/Fuel Type): External Combustion Boilers; Electrical Generation; Solid Waste; non-MSW material		
2. Source Classification Code (SCC): 1-01-012-01		3. SCC Units: Tons of non-MSW
4. Maximum Hourly Rate: 5.04	5. Maximum Annual Rate: 44,165	6. Estimated Annual Activity Factor:
7. Maximum % Sulfur:	8. Maximum % Ash:	9. Million Btu per SCC Unit:
10. Segment Comment: The total quantity of the non-MSW material received as segregated loads and burned at the facility is limited to 5%, by weight, of the facility's total fuel. See Condition B.16(a)(6) for a list of non-MSW that may be used as fuel at the facility. Maximum hourly rate: $0.05 \times 2,420 \text{ TPD} \times (\text{day}/24 \text{ hr}) = 5.04 \text{ tons/hr}$ Maximum annual rate: $0.05 \times 2,420 \text{ TPD} \times (365/\text{yr}) = 44,165 \text{ tons/yr}$		

Segment Description and Rate: Segment of

1. Segment Description (Process/Fuel Type):		
2. Source Classification Code (SCC):		3. SCC Units:
4. Maximum Hourly Rate:	5. Maximum Annual Rate:	6. Estimated Annual Activity Factor:
7. Maximum % Sulfur:	8. Maximum % Ash:	9. Million Btu per SCC Unit:
10. Segment Comment:		

EMISSIONS UNIT INFORMATION

Section [1]

MSW Combustor & Auxiliary Burners: Units 1, 2, and 3

E. EMISSIONS UNIT POLLUTANTS

List of Pollutants Emitted by Emissions Unit

1. Pollutant Emitted	2. Primary Control Device Code	3. Secondary Control Device Code	4. Pollutant Regulatory Code
CO	033		EL
DIOX	016		EL
FL	202, 016		EL
H021 - Beryllium	202, 016		EL
H027 - Cadmium	202, 016		EL
H106 - Hydrogen Chloride	202		EL
H114 - Mercury	202, 016		EL
NOx	107		EL
Pb	202, 016		EL
PM	016	202	EL
PM10	016	202	NS
SO2	202	016	EL

EMISSIONS UNIT INFORMATION

POLLUTANT DETAIL INFORMATION

Section [1]

Page [1] of [11]

MSW Combustor & Auxiliary Burners: Units 1, 2, and 3

Carbon Monoxide - CO

**F1. EMISSIONS UNIT POLLUTANT DETAIL INFORMATION -
POTENTIAL, FUGITIVE, AND ACTUAL EMISSIONS**

(Optional for unregulated emissions units.)

Complete a Subsection F1 for each pollutant identified in Subsection E if applying for an air construction permit or concurrent processing of an air construction permit and a revised or renewal Title V operation permit. Complete for each emissions-limited pollutant identified in Subsection E if applying for an air operation permit.

Potential, Estimated Fugitive, and Baseline & Projected Actual Emissions

1. Pollutant Emitted: CO		2. Total Percent Efficiency of Control:	
3. Potential Emissions: 95.4 lb/hour 417.3 tons/year		4. Synthetically Limited? <input type="checkbox"/> Yes <input checked="" type="checkbox"/> No	
5. Range of Estimated Fugitive Emissions (as applicable): to tons/year			
6. Emission Factor: 100 ppmvd @ 7-percent O₂ (per MSW combustor unit) Reference: Permit No. 0112120-009-AV		7. Emissions Method Code: 0	
8.a. Baseline Actual Emissions (if required): tons/year		8.b. Baseline 24-month Period: From: To:	
9.a. Projected Actual Emissions (if required): tons/year		9.b. Projected Monitoring Period: <input type="checkbox"/> 5 years <input type="checkbox"/> 10 years	
10. Calculation of Emissions: Equivalent emissions rates are 0.105 lb/MMBtu/unit, 31.8 lb/hr/unit or 139.1 tons/yr/unit (Permitting Note to Emissions Limitations and Standards, Permit No. 0112120-009-AV) Potential Emissions for 3 units Hourly = 31.8 lb/hr x 3 = 95.4 lb/hr Annual = 139.1 TPY x 3 = 417.3 TPY			
11. Potential, Fugitive, and Actual Emissions Comment: Emissions represent total for the three combustor units.			

EMISSIONS UNIT INFORMATION

POLLUTANT DETAIL INFORMATION

Section [1]

Page [1] of [11]

MSW Combustor & Auxiliary Burners: Units 1, 2, and 3

Carbon Monoxide - CO

**F2. EMISSIONS UNIT POLLUTANT DETAIL INFORMATION -
ALLOWABLE EMISSIONS**

Complete Subsection F2 if the pollutant identified in Subsection F1 is or would be subject to a numerical emissions limitation.

Allowable Emissions Allowable Emissions 1 of 1

1. Basis for Allowable Emissions Code: RULE	2. Future Effective Date of Allowable Emissions:
3. Allowable Emissions and Units: 100 ppmvd @ 7% O₂	4. Equivalent Allowable Emissions: 95.4 lb/hour 417.3 tons/year
5. Method of Compliance: CEMS - 4-hour Block Average	
6. Allowable Emissions Comment (Description of Operating Method): 40 CFR 60.34b(a) and PSD-FL-112(B). Emissions represent total for the three combustor units.	

Allowable Emissions Allowable Emissions ____ of ____

1. Basis for Allowable Emissions Code:	2. Future Effective Date of Allowable Emissions:
3. Allowable Emissions and Units:	4. Equivalent Allowable Emissions: lb/hour tons/year
5. Method of Compliance:	
6. Allowable Emissions Comment (Description of Operating Method):	

Allowable Emissions Allowable Emissions ____ of ____

1. Basis for Allowable Emissions Code:	2. Future Effective Date of Allowable Emissions:
3. Allowable Emissions and Units:	4. Equivalent Allowable Emissions: lb/hour tons/year
5. Method of Compliance:	
6. Allowable Emissions Comment (Description of Operating Method):	

EMISSIONS UNIT INFORMATION

POLLUTANT DETAIL INFORMATION

Section [1]

Page [2] of [11]

MSW Combustor & Auxiliary Burners: Units 1, 2, and 3

Dioxin/Furan – DIOX

**F1. EMISSIONS UNIT POLLUTANT DETAIL INFORMATION –
POTENTIAL, FUGITIVE, AND ACTUAL EMISSIONS**

(Optional for unregulated emissions units.)

Complete a Subsection F1 for each pollutant identified in Subsection E if applying for an air construction permit or concurrent processing of an air construction permit and a revised or renewal Title V operation permit. Complete for each emissions-limited pollutant identified in Subsection E if applying for an air operation permit.

Potential, Estimated Fugitive, and Baseline & Projected Actual Emissions

1. Pollutant Emitted: DIOX		2. Total Percent Efficiency of Control:	
3. Potential Emissions: 2.46x10⁻⁵ lb/hour 1.08x10⁻⁴ tons/year		4. Synthetically Limited? <input type="checkbox"/> Yes <input checked="" type="checkbox"/> No	
5. Range of Estimated Fugitive Emissions (as applicable): to tons/year			
6. Emission Factor: 30 ng/dscm @ 7-percent O₂ (per MSW combustor unit) Reference: Permit No. 0112120-009-AV		7. Emissions Method Code: 0	
8.a. Baseline Actual Emissions (if required): tons/year		8.b. Baseline 24-month Period: From: To:	
9.a. Projected Actual Emissions (if required): tons/year		9.b. Projected Monitoring Period: <input type="checkbox"/> 5 years <input type="checkbox"/> 10 years	
10. Calculation of Emissions: Equivalent emissions rates are 2.7×10^{-5} lb/MMBtu/unit, 8.2×10^{-5} lb/hr/unit or 3.6×10^{-5} tons/yr/unit (Permitting Note to Emissions Limitations and Standards, Permit No. 0112120-009-AV). Potential Emissions for 3 units Hourly = 8.2×10^{-5} lb/hr x 3 = 2.46×10^{-5} lb/hr Annual = 3.6×10^{-5} TPY x 3 = 1.08×10^{-4} TPY			
11. Potential, Fugitive, and Actual Emissions Comment: Emissions represent total for the three combustor units.			

EMISSIONS UNIT INFORMATION

POLLUTANT DETAIL INFORMATION

Section [1]

Page [2] of [11]

MSW Combustor & Auxiliary Burners: Units 1, 2, and 3

Dioxin/Furan – DIOX

**F2. EMISSIONS UNIT POLLUTANT DETAIL INFORMATION -
ALLOWABLE EMISSIONS**

Complete Subsection F2 if the pollutant identified in Subsection F1 is or would be subject to a numerical emissions limitation.

Allowable Emissions Allowable Emissions 1 of 1

1. Basis for Allowable Emissions Code: RULE	2. Future Effective Date of Allowable Emissions:
3. Allowable Emissions and Units: 30 ng/dscm @ 7-percent O₂	4. Equivalent Allowable Emissions: 2.46x10⁻⁵ lb/hour 1.08x10⁻⁴ tons/yea
5. Method of Compliance: EPA Method 23. Annual testing of each unit once every 3 years if test results ≤ 15 ng/dscm for all units over 2-year period.	
6. Allowable Emissions Comment (Description of Operating Method): 40 CFR 60.33b(c)(1)(ii) and PSD-FL-112(B). Emissions represent total for the three combustor units.	

Allowable Emissions Allowable Emissions ____ of ____

1. Basis for Allowable Emissions Code:	2. Future Effective Date of Allowable Emissions:
3. Allowable Emissions and Units:	4. Equivalent Allowable Emissions: lb/hour tons/year
5. Method of Compliance:	
6. Allowable Emissions Comment (Description of Operating Method):	

Allowable Emissions Allowable Emissions ____ of ____

1. Basis for Allowable Emissions Code:	2. Future Effective Date of Allowable Emissions:
3. Allowable Emissions and Units:	4. Equivalent Allowable Emissions: lb/hour tons/year
5. Method of Compliance:	
6. Allowable Emissions Comment (Description of Operating Method):	

EMISSIONS UNIT INFORMATION

POLLUTANT DETAIL INFORMATION

Section [1]

Page [3] of [11]

MSW Combustor & Auxiliary Burners: Units 1, 2, and 3

Fluorides - FL

**F1. EMISSIONS UNIT POLLUTANT DETAIL INFORMATION -
POTENTIAL, FUGITIVE, AND ACTUAL EMISSIONS**

(Optional for unregulated emissions units.)

Complete a Subsection F1 for each pollutant identified in Subsection E if applying for an air construction permit or concurrent processing of an air construction permit and a revised or renewal Title V operation permit. Complete for each emissions-limited pollutant identified in Subsection E if applying for an air operation permit.

Potential, Estimated Fugitive, and Baseline & Projected Actual Emissions

1. Pollutant Emitted: FL		2. Total Percent Efficiency of Control:	
3. Potential Emissions: 3.63 lb/hour 15.87 tons/year		4. Synthetically Limited? <input type="checkbox"/> Yes <input checked="" type="checkbox"/> No	
5. Range of Estimated Fugitive Emissions (as applicable): to tons/year			
6. Emission Factor: 0.0040 lb/MMBtu (per MSW combustor unit) Reference: Permit No. 0112120-009-AV		7. Emissions Method Code: 0	
8.a. Baseline Actual Emissions (if required): tons/year		8.b. Baseline 24-month Period: From: To:	
9.a. Projected Actual Emissions (if required): tons/year		9.b. Projected Monitoring Period: <input type="checkbox"/> 5 years <input type="checkbox"/> 10 years	
10. Calculation of Emissions: Equivalent emissions rates are 0.0040 lb/MMBtu/unit, 1.21 lb/hr/unit or 5.29 tons/yr/unit (Permitting Note to Emissions Limitations and Standards, Permit No. 0112120-009-AV). Potential Emissions for 3 units Hourly = 1.21 lb/hr x 3 = 3.63 lb/hr Annual = 5.29 TPY x 3 = 15.87 TPY			
11. Potential, Fugitive, and Actual Emissions Comment: Emissions represent total for the three combustor units.			

EMISSIONS UNIT INFORMATION

POLLUTANT DETAIL INFORMATION

Section [1]

Page [3] of [11]

MSW Combustor & Auxiliary Burners: Units 1, 2, and 3

Fluorides - FL

**F2. EMISSIONS UNIT POLLUTANT DETAIL INFORMATION -
ALLOWABLE EMISSIONS**

Complete Subsection F2 if the pollutant identified in Subsection F1 is or would be subject to a numerical emissions limitation.

Allowable Emissions Allowable Emissions 1 of 1

1. Basis for Allowable Emissions Code: OTHER	2. Future Effective Date of Allowable Emissions:
3. Allowable Emissions and Units: 0.0040 lb/MMBtu	4. Equivalent Allowable Emissions: 3.63 lb/hour 15.87 tons/year
5. Method of Compliance: EPA Method 13A, 13B, or modified Method 5 for fluorides. Every 5 years.	
6. Allowable Emissions Comment (Description of Operating Method): PSD-FL-112(B). Emissions represent total for the three combustor units.	

Allowable Emissions Allowable Emissions ____ of ____

1. Basis for Allowable Emissions Code:	2. Future Effective Date of Allowable Emissions:
3. Allowable Emissions and Units:	4. Equivalent Allowable Emissions: lb/hour tons/year
5. Method of Compliance:	
6. Allowable Emissions Comment (Description of Operating Method):	

Allowable Emissions Allowable Emissions ____ of ____

1. Basis for Allowable Emissions Code:	2. Future Effective Date of Allowable Emissions:
3. Allowable Emissions and Units:	4. Equivalent Allowable Emissions: lb/hour tons/year
5. Method of Compliance:	
6. Allowable Emissions Comment (Description of Operating Method):	

EMISSIONS UNIT INFORMATION

POLLUTANT DETAIL INFORMATION

Section [1]

Page [4] of [11]

MSW Combustor & Auxiliary Burners: Units 1, 2, and 3

Beryllium - H021

**F1. EMISSIONS UNIT POLLUTANT DETAIL INFORMATION –
POTENTIAL, FUGITIVE, AND ACTUAL EMISSIONS**

(Optional for unregulated emissions units.)

Complete a Subsection F1 for each pollutant identified in Subsection E if applying for an air construction permit or concurrent processing of an air construction permit and a revised or renewal Title V operation permit. Complete for each emissions-limited pollutant identified in Subsection E if applying for an air operation permit.

Potential, Estimated Fugitive, and Baseline & Projected Actual Emissions

1. Pollutant Emitted: Beryllium - H021		2. Total Percent Efficiency of Control:	
3. Potential Emissions: 0.0009 lb/hour 0.0036 tons/year		4. Synthetically Limited? <input type="checkbox"/> Yes <input checked="" type="checkbox"/> No	
5. Range of Estimated Fugitive Emissions (as applicable): to tons/year			
6. Emission Factor: 0.001 mg/dscm @ 7-percent O₂ (per MSW combustor unit) Reference: Permit No. 0112120-009-AV		7. Emissions Method Code: 0	
8.a. Baseline Actual Emissions (if required): tons/year		8.b. Baseline 24-month Period: From: To:	
9.a. Projected Actual Emissions (if required): tons/year		9.b. Projected Monitoring Period: <input type="checkbox"/> 5 years <input type="checkbox"/> 10 years	
10. Calculation of Emissions: Equivalent emissions rates are 9.3×10^{-7} lb/MMBtu/unit, 0.0003 lb/hr/unit or 0.0012 tons/yr/unit (Permitting Note to Emissions Limitations and Standards, Permit No. 0112120-009-AV). Potential Emissions for 3 units Hourly = 0.0003 lb/hr x 3 = 0.0009 lb/hr Annual = 0.0012 TPY x 3 = 0.0036 TPY			
11. Potential, Fugitive, and Actual Emissions Comment: Emissions represent total for the three combustor units.			

**F2. EMISSIONS UNIT POLLUTANT DETAIL INFORMATION -
ALLOWABLE EMISSIONS**

Complete Subsection F2 if the pollutant identified in Subsection F1 is or would be subject to a numerical emissions limitation.

Allowable Emissions Allowable Emissions 1 of 1

1. Basis for Allowable Emissions Code: OTHER	2. Future Effective Date of Allowable Emissions:
3. Allowable Emissions and Units: 0.001 mg/dscm @ 7-percent O₂	4. Equivalent Allowable Emissions: 0.0009 lb/hour 0.0036 tons/year
5. Method of Compliance: EPA Method 29, annually	
6. Allowable Emissions Comment (Description of Operating Method): PSD-FL-112(B). Emissions represent total for the three combustor units.	

Allowable Emissions Allowable Emissions ____ of ____

1. Basis for Allowable Emissions Code:	2. Future Effective Date of Allowable Emissions:
3. Allowable Emissions and Units:	4. Equivalent Allowable Emissions: lb/hour tons/year
5. Method of Compliance:	
6. Allowable Emissions Comment (Description of Operating Method):	

Allowable Emissions Allowable Emissions ____ of ____

1. Basis for Allowable Emissions Code:	2. Future Effective Date of Allowable Emissions:
3. Allowable Emissions and Units:	4. Equivalent Allowable Emissions: lb/hour tons/year
5. Method of Compliance:	
6. Allowable Emissions Comment (Description of Operating Method):	

EMISSIONS UNIT INFORMATION

POLLUTANT DETAIL INFORMATION

Section [1]

Page [5] of [11]

MSW Combustor & Auxiliary Burners: Units 1, 2, and 3

Cadmium – H027

**F1. EMISSIONS UNIT POLLUTANT DETAIL INFORMATION –
POTENTIAL, FUGITIVE, AND ACTUAL EMISSIONS**

(Optional for unregulated emissions units.)

Complete a Subsection F1 for each pollutant identified in Subsection E if applying for an air construction permit or concurrent processing of an air construction permit and a revised or renewal Title V operation permit. Complete for each emissions-limited pollutant identified in Subsection E if applying for an air operation permit.

Potential, Estimated Fugitive, and Baseline & Projected Actual Emissions

1. Pollutant Emitted: Cadmium – H027		2. Total Percent Efficiency of Control:	
3. Potential Emissions: 0.029 lb/hour 0.126 tons/year		4. Synthetically Limited? <input type="checkbox"/> Yes <input checked="" type="checkbox"/> No	
5. Range of Estimated Fugitive Emissions (as applicable): to tons/year			
6. Emission Factor: 0.035 mg/dscm @ 7-percent O₂ (per MSW combustor unit) Reference: 40 CFR 60 Subpart Cb		7. Emissions Method Code: 0	
8.a. Baseline Actual Emissions (if required): tons/year		8.b. Baseline 24-month Period: From: To:	
9.a. Projected Actual Emissions (if required): tons/year		9.b. Projected Monitoring Period: <input type="checkbox"/> 5 years <input type="checkbox"/> 10 years	
10. Calculation of Emissions: Equivalent emissions rates are 3.15×10^{-5} lb/MMBtu/unit, 9.6×10^{-3} lb/hr/unit or 0.042 tons/yr/unit. <u>Potential Emissions for 3 units</u> Hourly = $0.011 \times (0.035/0.040)$ lb/hr x 3 = 0.029 lb/hr Annual = $0.048 \times (0.035/0.040)$ TPY x 3 = 0.126 TPY Potential emissions calculated based on Permitting Note to Emissions Limitations and Standards, Permit No. 0112120-009-AV and prorating using the Subpart Cb limits before and after April 28, 2009.			
11. Potential, Fugitive, and Actual Emissions Comment: Emissions represent total for the three combustor units. Emission factor reflects 40 CFR 60 Subpart Cb limit effective after April 28, 2009.			

EMISSIONS UNIT INFORMATION

POLLUTANT DETAIL INFORMATION

Section [1]

Page [5] of [11]

MSW Combustor & Auxiliary Burners: Units 1, 2, and 3

Cadmium - H027

**F2. EMISSIONS UNIT POLLUTANT DETAIL INFORMATION -
ALLOWABLE EMISSIONS**

Complete Subsection F2 if the pollutant identified in Subsection F1 is or would be subject to a numerical emissions limitation.

Allowable Emissions Allowable Emissions 1 of 1

1. Basis for Allowable Emissions Code: RULE	2. Future Effective Date of Allowable Emissions:
3. Allowable Emissions and Units: 0.035 mg/dscm @ 7-percent O₂	4. Equivalent Allowable Emissions: 0.029 lb/hour 0.126 tons/year
5. Method of Compliance: EPA Method 29, annually	
6. Allowable Emissions Comment (Description of Operating Method): 40 CFR 60.33b(a)(2)(i). Emissions represent total for the three combustor units.	

Allowable Emissions Allowable Emissions ____ of ____

1. Basis for Allowable Emissions Code:	2. Future Effective Date of Allowable Emissions:
3. Allowable Emissions and Units:	4. Equivalent Allowable Emissions: lb/hour tons/year
5. Method of Compliance:	
6. Allowable Emissions Comment (Description of Operating Method):	

Allowable Emissions Allowable Emissions ____ of ____

1. Basis for Allowable Emissions Code:	2. Future Effective Date of Allowable Emissions:
3. Allowable Emissions and Units:	4. Equivalent Allowable Emissions: lb/hour tons/year
5. Method of Compliance:	
6. Allowable Emissions Comment (Description of Operating Method):	

EMISSIONS UNIT INFORMATION

POLLUTANT DETAIL INFORMATION

Section [1]

Page [6] of [11]

MSW Combustor & Auxiliary Burners: Units 1, 2, and 3

Hydrogen Chloride – H106

**F1. EMISSIONS UNIT POLLUTANT DETAIL INFORMATION –
POTENTIAL, FUGITIVE, AND ACTUAL EMISSIONS**

(Optional for unregulated emissions units.)

Complete a Subsection F1 for each pollutant identified in Subsection E if applying for an air construction permit or concurrent processing of an air construction permit and a revised or renewal Title V operation permit. Complete for each emissions-limited pollutant identified in Subsection E if applying for an air operation permit.

Potential, Estimated Fugitive, and Baseline & Projected Actual Emissions

1. Pollutant Emitted: Hydrogen Chloride – H106		2. Total Percent Efficiency of Control: 95	
3. Potential Emissions: 35.1 lb/hour 153.9 tons/year		4. Synthetically Limited? <input type="checkbox"/> Yes <input checked="" type="checkbox"/> No	
5. Range of Estimated Fugitive Emissions (as applicable): to tons/year			
6. Emission Factor: 29 ppmvd @ 7-percent O₂ (per MSW combustor unit) Reference: Permit No. 0112120-009-AV		7. Emissions Method Code: 0	
8.a. Baseline Actual Emissions (if required): tons/year		8.b. Baseline 24-month Period: From: To:	
9.a. Projected Actual Emissions (if required): tons/year		9.b. Projected Monitoring Period: <input type="checkbox"/> 5 years <input type="checkbox"/> 10 years	
10. Calculation of Emissions: Equivalent emissions rates are 0.04 lb/MMBtu/unit, 11.7 lb/hr/unit or 51.3 tons/yr/unit (Permitting Note to Emissions Limitations and Standards, Permit No. 0112120-009-AV). <u>Potential Emissions for 3 units</u> Hourly = 11.7 lb/hr x 3 = 35.1 lb/hr Annual = 51.3 TPY x 3 = 153.9 TPY			
11. Potential, Fugitive, and Actual Emissions Comment: Emissions represent total for the three combustor units.			

EMISSIONS UNIT INFORMATION

POLLUTANT DETAIL INFORMATION

Section [1]

Page [6] of [11]

MSW Combustor & Auxiliary Burners: Units 1, 2, and 3

Hydrogen Chloride - H106

**F2. EMISSIONS UNIT POLLUTANT DETAIL INFORMATION -
ALLOWABLE EMISSIONS**

Complete Subsection F2 if the pollutant identified in Subsection F1 is or would be subject to a numerical emissions limitation.

Allowable Emissions Allowable Emissions 1 of 1

1. Basis for Allowable Emissions Code: RULE	2. Future Effective Date of Allowable Emissions:
3. Allowable Emissions and Units: 29 ppmvd @ 7-percent O₂	4. Equivalent Allowable Emissions: 35.1 lb/hour 153.9 tons/year
5. Method of Compliance: EPA Method 26, 26A; annually	
6. Allowable Emissions Comment (Description of Operating Method): 29 ppmvd @ 7-percent O₂ or 95-percent reduction by weight or volume, whichever is less stringent. 40 CFR 60.33b(3)(ii) and PSD-FL-112(B). Emissions represent total for the three combustor units.	

Allowable Emissions Allowable Emissions ____ of ____

1. Basis for Allowable Emissions Code:	2. Future Effective Date of Allowable Emissions:
3. Allowable Emissions and Units:	4. Equivalent Allowable Emissions: lb/hour tons/year
5. Method of Compliance:	
6. Allowable Emissions Comment (Description of Operating Method):	

Allowable Emissions Allowable Emissions ____ of ____

1. Basis for Allowable Emissions Code:	2. Future Effective Date of Allowable Emissions:
3. Allowable Emissions and Units:	4. Equivalent Allowable Emissions: lb/hour tons/year
5. Method of Compliance:	
6. Allowable Emissions Comment (Description of Operating Method):	

**F1. EMISSIONS UNIT POLLUTANT DETAIL INFORMATION -
POTENTIAL, FUGITIVE, AND ACTUAL EMISSIONS**
(Optional for unregulated emissions units.)

Complete a Subsection F1 for each pollutant identified in Subsection E if applying for an air construction permit or concurrent processing of an air construction permit and a revised or renewal Title V operation permit. Complete for each emissions-limited pollutant identified in Subsection E if applying for an air operation permit.

Potential, Estimated Fugitive, and Baseline & Projected Actual Emissions

1. Pollutant Emitted: Mercury - H114		2. Total Percent Efficiency of Control:	
3. Potential Emissions: 0.041 lb/hour 0.17 tons/year		4. Synthetically Limited? <input type="checkbox"/> Yes <input checked="" type="checkbox"/> No	
5. Range of Estimated Fugitive Emissions (as applicable): to tons/year			
6. Emission Factor: 0.050 mg/dscm @ 7-percent O₂ (per MSW combustor unit) Reference: 40 CFR 60 Subpart Cb		7. Emissions Method Code: 0	
8.a. Baseline Actual Emissions (if required): tons/year		8.b. Baseline 24-month Period: From: To:	
9.a. Projected Actual Emissions (if required): tons/year		9.b. Projected Monitoring Period: <input type="checkbox"/> 5 years <input type="checkbox"/> 10 years	
10. Calculation of Emissions: Equivalent emissions rates are 4.5×10^{-5} lb/MMBtu/unit, 0.014 lb/hr/unit or 0.057 tons/yr/unit. <u>Potential Emissions for 3 units</u> Hourly = $0.019 \times (0.050/0.070) \text{ lb/hr} \times 3 = 0.041 \text{ lb/hr}$ Annual = $0.08 \times (0.050/0.070) \text{ TPY} \times 3 = 0.17 \text{ TPY}$ Potential emissions calculated based on Permitting Note to Emissions Limitations and Standards, Permit No. 0112120-009-AV and prorating using the Subpart Cb limits before and after April 28, 2009.			
11. Potential, Fugitive, and Actual Emissions Comment: Emissions represent total for the three combustor units. Emission factor reflects 40 CFR 60 Subpart Cb limit effective after April 28, 2009.			

EMISSIONS UNIT INFORMATION

POLLUTANT DETAIL INFORMATION

Section [1]

Page [7] of [11]

MSW Combustor & Auxiliary Burners: Units 1, 2, and 3

Mercury – H114

**F2. EMISSIONS UNIT POLLUTANT DETAIL INFORMATION -
ALLOWABLE EMISSIONS**

Complete Subsection F2 if the pollutant identified in Subsection F1 is or would be subject to a numerical emissions limitation.

Allowable Emissions Allowable Emissions 1 of 1

1. Basis for Allowable Emissions Code: RULE	2. Future Effective Date of Allowable Emissions:
3. Allowable Emissions and Units: 0.050 mg/dscm @ 7-percent O₂	4. Equivalent Allowable Emissions: 0.041 lb/hour 0.17 tons/year
5. Method of Compliance: EPA Method 29, annually	
6. Allowable Emissions Comment (Description of Operating Method): 0.050 mg/dscm @ 7-percent O₂ or 85-percent reduction by weight, whichever is less stringent. 40 CFR 60.33b(a)(3) and PSD-FL-112(B). Emissions represent total for the three combustor units.	

Allowable Emissions Allowable Emissions ____ of ____

1. Basis for Allowable Emissions Code:	2. Future Effective Date of Allowable Emissions:
3. Allowable Emissions and Units:	4. Equivalent Allowable Emissions: lb/hour tons/year
5. Method of Compliance:	
6. Allowable Emissions Comment (Description of Operating Method):	

Allowable Emissions Allowable Emissions ____ of ____

1. Basis for Allowable Emissions Code:	2. Future Effective Date of Allowable Emissions:
3. Allowable Emissions and Units:	4. Equivalent Allowable Emissions: lb/hour tons/year
5. Method of Compliance:	
6. Allowable Emissions Comment (Description of Operating Method):	

**F1. EMISSIONS UNIT POLLUTANT DETAIL INFORMATION –
POTENTIAL, FUGITIVE, AND ACTUAL EMISSIONS**

(Optional for unregulated emissions units.)

Complete a Subsection F1 for each pollutant identified in Subsection E if applying for an air construction permit or concurrent processing of an air construction permit and a revised or renewal Title V operation permit. Complete for each emissions-limited pollutant identified in Subsection E if applying for an air operation permit.

Potential, Estimated Fugitive, and Baseline & Projected Actual Emissions

1. Pollutant Emitted: NOx		2. Total Percent Efficiency of Control:	
3. Potential Emissions: 319.5 lb/hour 1,399 tons/year		4. Synthetically Limited? <input type="checkbox"/> Yes <input checked="" type="checkbox"/> No	
5. Range of Estimated Fugitive Emissions (as applicable): to tons/year			
6. Emission Factor: 205 ppmvd @ 7-percent O₂ (per MSW combustor unit) Reference: Permit No. 0112120-009-AV		7. Emissions Method Code: 0	
8.a. Baseline Actual Emissions (if required): tons/year		8.b. Baseline 24-month Period: From: To:	
9.a. Projected Actual Emissions (if required): tons/year		9.b. Projected Monitoring Period: <input type="checkbox"/> 5 years <input type="checkbox"/> 10 years	
10. Calculation of Emissions: <p>Equivalent emissions rates are 0.35 lb/MMBtu/unit, 106.5 lb/hr/unit or 466.4 tons/yr/unit (Permitting Note to Emissions Limitations and Standards, Permit No. 0112120-009-AV).</p> <p><u>Potential Emissions for 3 units</u> Hourly = 106.5 lb/hr x 3 = 319.5 lb/hr Annual = 466.4 TPY x 3 = 1,399 TPY</p>			
11. Potential, Fugitive, and Actual Emissions Comment: Emissions represent total for the three combustor units.			

EMISSIONS UNIT INFORMATION

POLLUTANT DETAIL INFORMATION

Section [1]

Page [8] of [11]

MSW Combustor & Auxiliary Burners: Units 1, 2, and 3

Nitrogen Oxides – NOx

**F2. EMISSIONS UNIT POLLUTANT DETAIL INFORMATION -
ALLOWABLE EMISSIONS**

Complete Subsection F2 if the pollutant identified in Subsection F1 is or would be subject to a numerical emissions limitation.

Allowable Emissions Allowable Emissions 1 of 1

1. Basis for Allowable Emissions Code: RULE	2. Future Effective Date of Allowable Emissions:
3. Allowable Emissions and Units: 205 ppmvd @ 7-percent O₂	4. Equivalent Allowable Emissions: 319.5 lb/hour 1,399 tons/year
5. Method of Compliance: CEMS 24-hour daily arithmetic average.	
6. Allowable Emissions Comment (Description of Operating Method): 40 CFR 60.33b(d) and PSD-FL-112(B). Emissions represent total for the three combustor units.	

Allowable Emissions Allowable Emissions ____ of ____

1. Basis for Allowable Emissions Code:	2. Future Effective Date of Allowable Emissions:
3. Allowable Emissions and Units:	4. Equivalent Allowable Emissions: lb/hour tons/year
5. Method of Compliance:	
6. Allowable Emissions Comment (Description of Operating Method):	

Allowable Emissions Allowable Emissions ____ of ____

1. Basis for Allowable Emissions Code:	2. Future Effective Date of Allowable Emissions:
3. Allowable Emissions and Units:	4. Equivalent Allowable Emissions: lb/hour tons/year
5. Method of Compliance:	
6. Allowable Emissions Comment (Description of Operating Method):	

**F1. EMISSIONS UNIT POLLUTANT DETAIL INFORMATION -
POTENTIAL, FUGITIVE, AND ACTUAL EMISSIONS**

(Optional for unregulated emissions units.)

Complete a Subsection F1 for each pollutant identified in Subsection E if applying for an air construction permit or concurrent processing of an air construction permit and a revised or renewal Title V operation permit. Complete for each emissions-limited pollutant identified in Subsection E if applying for an air operation permit.

Potential, Estimated Fugitive, and Baseline & Projected Actual Emissions

1. Pollutant Emitted: Pb		2. Total Percent Efficiency of Control:	
3. Potential Emissions: 0.36 lb/hour 1.58 tons/year		4. Synthetically Limited? <input type="checkbox"/> Yes <input checked="" type="checkbox"/> No	
5. Range of Estimated Fugitive Emissions (as applicable): to tons/year			
6. Emission Factor: 0.40 mg/dscm @ 7-percent O₂ (per MSW combustor unit) Reference: 40 CFR 60 Subpart Cb		7. Emissions Method Code: 0	
8.a. Baseline Actual Emissions (if required): tons/year		8.b. Baseline 24-month Period: From: To:	
9.a. Projected Actual Emissions (if required): tons/year		9.b. Projected Monitoring Period: <input type="checkbox"/> 5 years <input type="checkbox"/> 10 years	
10. Calculation of Emissions: Equivalent emissions rates are 4.0×10^{-4} lb/MMBtu/unit, 0.12 lb/hr/unit or 0.53 tons/yr/unit. Potential Emissions for 3 units Hourly = $0.133 \times (0.40/0.44)$ lb/hr x 3 = 0.36 lb/hr Annual = $0.58 \times (0.40/0.44)$ TPY x 3 = 1.58 TPY Potential emissions calculated based on Permitting Note to Emissions Limitations and Standards, Permit No. 0112120-009-AV and prorating using the Subpart Cb limits before and after April 28, 2009.			
11. Potential, Fugitive, and Actual Emissions Comment: Emissions represent total for the three combustor units. Emission factor reflects 40 CFR 60 Subpart Cb limit effective after April 28, 2009.			

EMISSIONS UNIT INFORMATION

POLLUTANT DETAIL INFORMATION

Section [1]

Page [9] of [11]

MSW Combustor & Auxiliary Burners: Units 1, 2, and 3

Lead - Pb

**F2. EMISSIONS UNIT POLLUTANT DETAIL INFORMATION -
ALLOWABLE EMISSIONS**

Complete Subsection F2 if the pollutant identified in Subsection F1 is or would be subject to a numerical emissions limitation.

Allowable Emissions Allowable Emissions 1 of 1

1. Basis for Allowable Emissions Code: RULE	2. Future Effective Date of Allowable Emissions:
3. Allowable Emissions and Units: 0.40 mg/dscm @ 7-percent O₂	4. Equivalent Allowable Emissions: 0.36 lb/hour 1.58 tons/year
5. Method of Compliance: EPA Method 29, annually	
6. Allowable Emissions Comment (Description of Operating Method): 40 CFR 60.33b(a)(4). Emissions represent total for the three combustor units.	

Allowable Emissions Allowable Emissions ____ of ____

1. Basis for Allowable Emissions Code:	2. Future Effective Date of Allowable Emissions:
3. Allowable Emissions and Units:	4. Equivalent Allowable Emissions: lb/hour tons/year
5. Method of Compliance:	
6. Allowable Emissions Comment (Description of Operating Method):	

Allowable Emissions Allowable Emissions ____ of ____

1. Basis for Allowable Emissions Code:	2. Future Effective Date of Allowable Emissions:
3. Allowable Emissions and Units:	4. Equivalent Allowable Emissions: lb/hour tons/year
5. Method of Compliance:	
6. Allowable Emissions Comment (Description of Operating Method):	

EMISSIONS UNIT INFORMATION

POLLUTANT DETAIL INFORMATION

Section [1]

Page [10] of [11]

MSW Combustor & Auxiliary Burners: Units 1, 2, and 3

Particulate Matter Total – PM

**F1. EMISSIONS UNIT POLLUTANT DETAIL INFORMATION –
POTENTIAL, FUGITIVE, AND ACTUAL EMISSIONS**

(Optional for unregulated emissions units.)

Complete a Subsection F1 for each pollutant identified in Subsection E if applying for an air construction permit or concurrent processing of an air construction permit and a revised or renewal Title V operation permit. Complete for each emissions-limited pollutant identified in Subsection E if applying for an air operation permit.

Potential, Estimated Fugitive, and Baseline & Projected Actual Emissions

1. Pollutant Emitted: PM		2. Total Percent Efficiency of Control: 99+	
3. Potential Emissions: 20.42 lb/hour 89.55 tons/year		4. Synthetically Limited? <input type="checkbox"/> Yes <input checked="" type="checkbox"/> No	
5. Range of Estimated Fugitive Emissions (as applicable): to tons/year			
6. Emission Factor: 25 mg/dscm @ 7-percent O₂ (per MSW combustor unit) Reference: 40 CFR 60 Subpart Cb		7. Emissions Method Code: 0	
8.a. Baseline Actual Emissions (if required): tons/year		8.b. Baseline 24-month Period: From: To:	
9.a. Projected Actual Emissions (if required): tons/year		9.b. Projected Monitoring Period: <input type="checkbox"/> 5 years <input type="checkbox"/> 10 years	
10. Calculation of Emissions: <p>Equivalent emissions rates are 0.022 lb/MMBtu/unit, 6.81 lb/hr/unit or 29.85 tons/yr/unit.</p> <p><u>Potential Emissions for 3 units</u> Hourly = 7.35 x (0.25/0.27) lb/hr x 3 = 20.42 lb/hr Annual = 32.24 x (0.25/0.27) TPY x 3 = 89.55 TPY</p> <p>Potential emissions calculated based on Permitting Note to Emissions Limitations and Standards, Permit No. 0112120-009-AV and prorating using the Subpart Cb limits before and after April 28, 2009.</p>			
11. Potential, Fugitive, and Actual Emissions Comment: <p>Emissions represent total for the three combustor units. Emission factor reflects 40 CFR 60 Subpart Cb limit effective after April 28, 2009.</p>			

EMISSIONS UNIT INFORMATION

POLLUTANT DETAIL INFORMATION

Section [1]

Page [10] of [11]

MSW Combustor & Auxiliary Burners: Units 1, 2, and 3

Particulate Matter Total - PM

F2. EMISSIONS UNIT POLLUTANT DETAIL INFORMATION -

ALLOWABLE EMISSIONS

Complete Subsection F2 if the pollutant identified in Subsection F1 is or would be subject to a numerical emissions limitation.

Allowable Emissions Allowable Emissions 1 of 1

1. Basis for Allowable Emissions Code: RULE	2. Future Effective Date of Allowable Emissions:
3. Allowable Emissions and Units: 25 mg/dscm @ 7-percent O₂ for PM	4. Equivalent Allowable Emissions: 20.42 lb/hour 89.55 tons/year
5. Method of Compliance: EPA Method 5; annually	
6. Allowable Emissions Comment (Description of Operating Method): 40 CFR 60.33b(a)(1)(i). Emissions represent total for the three combustor units.	

Allowable Emissions Allowable Emissions ____ of ____

1. Basis for Allowable Emissions Code:	2. Future Effective Date of Allowable Emissions:
3. Allowable Emissions and Units:	4. Equivalent Allowable Emissions: lb/hour tons/year
5. Method of Compliance:	
6. Allowable Emissions Comment (Description of Operating Method):	

Allowable Emissions Allowable Emissions ____ of ____

1. Basis for Allowable Emissions Code:	2. Future Effective Date of Allowable Emissions:
3. Allowable Emissions and Units:	4. Equivalent Allowable Emissions: lb/hour tons/year
5. Method of Compliance:	
6. Allowable Emissions Comment (Description of Operating Method):	

EMISSIONS UNIT INFORMATION

POLLUTANT DETAIL INFORMATION

Section [1]

Page [11] of [11]

MSW Combustor & Auxiliary Burners: Units 1, 2, and 3

Sulfur Dioxide – SO2

**F1. EMISSIONS UNIT POLLUTANT DETAIL INFORMATION –
POTENTIAL, FUGITIVE, AND ACTUAL EMISSIONS**

(Optional for unregulated emissions units.)

Complete a Subsection F1 for each pollutant identified in Subsection E if applying for an air construction permit or concurrent processing of an air construction permit and a revised or renewal Title V operation permit. Complete for each emissions-limited pollutant identified in Subsection E if applying for an air operation permit.

Potential, Estimated Fugitive, and Baseline & Projected Actual Emissions

1. Pollutant Emitted: SO2		2. Total Percent Efficiency of Control: 75	
3. Potential Emissions: 98.4 lb/hour 430.5 tons/year		4. Synthetically Limited? <input type="checkbox"/> Yes <input checked="" type="checkbox"/> No	
5. Range of Estimated Fugitive Emissions (as applicable): to tons/year			
6. Emission Factor: 29 ppmvd @ 7-percent O₂ (per MSW combustor unit) Reference: Permit No. 0112120-009-AV		7. Emissions Method Code: 0	
8.a. Baseline Actual Emissions (if required): tons/year		8.b. Baseline 24-month Period: From: To:	
9.a. Projected Actual Emissions (if required): tons/year		9.b. Projected Monitoring Period: <input type="checkbox"/> 5 years <input type="checkbox"/> 10 years	
10. Calculation of Emissions: <p>Equivalent emissions rates are 0.11 lb/MMBtu/unit, 32.8 lb/hr/unit or 143.5 tons/yr/unit (Permitting Note to Emissions Limitations and Standards, Permit No. 0112120-009-AV).</p> <p><u>Potential Emissions for 3 units</u> Hourly = 32.8 lb/hr x 3 = 98.4 lb/hr Annual = 143.5 TPY x 3 = 430.5 TPY</p>			
11. Potential, Fugitive, and Actual Emissions Comment: <p>Emissions represent total for the three combustor units. Sulfur content of the fuel limited to 0.3% by weight (not federally enforceable).</p>			

EMISSIONS UNIT INFORMATION

POLLUTANT DETAIL INFORMATION

Section [1]

Page [11] of [11]

MSW Combustor & Auxiliary Burners: Units 1, 2, and 3

Sulfur Dioxide - SO2

**F2. EMISSIONS UNIT POLLUTANT DETAIL INFORMATION -
ALLOWABLE EMISSIONS**

Complete Subsection F2 if the pollutant identified in Subsection F1 is or would be subject to a numerical emissions limitation.

Allowable Emissions Allowable Emissions 1 of 1

1. Basis for Allowable Emissions Code: RULE	2. Future Effective Date of Allowable Emissions:
3. Allowable Emissions and Units: 29 ppmvd @ 7-percent O₂	4. Equivalent Allowable Emissions: 98.4 lb/hour 430.5 tons/year
5. Method of Compliance: CEMS 24-hour block daily geometric mean.	
6. Allowable Emissions Comment (Description of Operating Method): 29 ppmvd @ 7-percent O₂ or 75-percent reduction by weight or volume, whichever is less stringent. [40 CFR 60.33b (b)(3)(i) and PSD-FL-112(B)] Emissions represent total for the three combustor units.	

Allowable Emissions Allowable Emissions ____ of ____

1. Basis for Allowable Emissions Code:	2. Future Effective Date of Allowable Emissions:
3. Allowable Emissions and Units:	4. Equivalent Allowable Emissions: lb/hour tons/year
5. Method of Compliance:	
6. Allowable Emissions Comment (Description of Operating Method):	

Allowable Emissions Allowable Emissions ____ of ____

1. Basis for Allowable Emissions Code:	2. Future Effective Date of Allowable Emissions:
3. Allowable Emissions and Units:	4. Equivalent Allowable Emissions: lb/hour tons/year
5. Method of Compliance:	
6. Allowable Emissions Comment (Description of Operating Method):	

EMISSIONS UNIT INFORMATION

Section [1]

MSW Combustor & Auxiliary Burners: Units 1, 2, and 3

G. VISIBLE EMISSIONS INFORMATION

Complete Subsection G if this emissions unit is or would be subject to a unit-specific visible emissions limitation.

Visible Emissions Limitation: Visible Emissions Limitation 1 of 1

1. Visible Emissions Subtype: VE10	2. Basis for Allowable Opacity: <input checked="" type="checkbox"/> Rule <input type="checkbox"/> Other
3. Allowable Opacity: Normal Conditions: 10 % Exceptional Conditions: 100 % Maximum Period of Excess Opacity Allowed: _____ min/hour	
4. Method of Compliance: EPA Method 9, annually	
5. Visible Emissions Comment: 6-minute average; 40 CFR 60.33b (a)(1)(iii) and PSD-FL-112(B) Exceptional Conditions: Periods of startup, shutdown, and malfunction. Duration of startup or shutdown periods are limited to 3 hours per occurrence, except as provided in 40 CFR 60.33b(a)(1)(iii).	

Visible Emissions Limitation: Visible Emissions Limitation ____ of ____

1. Visible Emissions Subtype:	2. Basis for Allowable Opacity: <input type="checkbox"/> Rule <input type="checkbox"/> Other
3. Allowable Opacity: Normal Conditions: _____ % Exceptional Conditions: _____ % Maximum Period of Excess Opacity Allowed: _____ min/hour	
4. Method of Compliance:	
5. Visible Emissions Comment:	

EMISSIONS UNIT INFORMATION

Section [1]

MSW Combustor & Auxiliary Burners: Units 1, 2, and 3

H. CONTINUOUS MONITOR INFORMATION

Complete Subsection H if this emissions unit is or would be subject to continuous monitoring.

Continuous Monitoring System: Continuous Monitor 1 of 7

1. Parameter Code: O2 - Oxygen	2. Pollutant(s):
3. CMS Requirement:	<input type="checkbox"/> Rule <input checked="" type="checkbox"/> Other
4. Monitor Information... Manufacturer: SICK MAIHAK Model Number: MCS-100E Serial Number:	
5. Installation Date:	6. Performance Specification Test Date:
7. Continuous Monitor Comment: Used with SO₂, NO_x, and CO monitors.	

Continuous Monitoring System: Continuous Monitor 2 of 7

1. Parameter Code: EM - Emission	2. Pollutant(s): SO2
3. CMS Requirement:	<input type="checkbox"/> Rule <input checked="" type="checkbox"/> Other
4. Monitor Information... Manufacturer: SICK MAIHAK Model Number: MCS-100E Serial Number: 280, 281, and 271	
5. Installation Date: 02/01/2001	6. Performance Specification Test Date:
7. Continuous Monitor Comment: Used with SO₂, NO_x, and CO monitors Boiler No. 1 - Serial Number: 280 Boiler No. 2 - Serial Number: 281 Boiler No. 3 - Serial Number: 271	

EMISSIONS UNIT INFORMATION

Section [1]

MSW Combustor & Auxiliary Burners: Units 1, 2, and 3

H. CONTINUOUS MONITOR INFORMATION (CONTINUED)

Continuous Monitoring System: Continuous Monitor 3 of 7

1. Parameter Code: EM – Emission	2. Pollutant(s): NOx
3. CMS Requirement:	<input type="checkbox"/> Rule <input checked="" type="checkbox"/> Other
4. Monitor Information... Manufacturer: SICK MAIHAK Model Number: MCS-100E Serial Number: 280, 281, and 271	
5. Installation Date: 02/01/2001	6. Performance Specification Test Date:
7. Continuous Monitor Comment: Boiler No. 1 - Serial Number: 280 Boiler No. 2 - Serial Number: 281 Boiler No. 3 - Serial Number: 271	

Continuous Monitoring System: Continuous Monitor 4 of 7

1. Parameter Code: EM – Emission	2. Pollutant(s): CO
3. CMS Requirement:	<input type="checkbox"/> Rule <input checked="" type="checkbox"/> Other
4. Monitor Information... Manufacturer: SICK MAIHAK Model Number: MCS-100E Serial Number: 280, 281, and 271	
5. Installation Date: 02/01/2001	6. Performance Specification Test Date:
7. Continuous Monitor Comment: Boiler No. 1 - Serial Number: 280 Boiler No. 2 - Serial Number: 281 Boiler No. 3 - Serial Number: 271	

EMISSIONS UNIT INFORMATION

Section [1]

MSW Combustor & Auxiliary Burners: Units 1, 2, and 3

H. CONTINUOUS MONITOR INFORMATION (CONTINUED)

Continuous Monitoring System: Continuous Monitor 5 of 7

1. Parameter Code: VE – Visible Emissions (opacity)	2. Pollutant(s):
3. CMS Requirement:	<input type="checkbox"/> Rule <input checked="" type="checkbox"/> Other
4. Monitor Information... Manufacturer: LAND INSTRUMENTAL INC. Model Number: 4500 MKII Serial Number: See Comment	
5. Installation Date: 07/21/2003	6. Performance Specification Test Date:
7. Continuous Monitor Comment: MSW Combustor Unit 1 – Serial Number 0295820 MSW Combustor Unit 2 – Serial Number 0295848 MSW Combustor Unit 3 – Serial Number 0295828	

Continuous Monitoring System: Continuous Monitor 6 of 7

1. Parameter Code: TEMP	2. Pollutant(s):
3. CMS Requirement:	<input checked="" type="checkbox"/> Rule <input type="checkbox"/> Other
4. Monitor Information... Manufacturer: See Comment Model Number: Serial Number:	
5. Installation Date:	6. Performance Specification Test Date:
7. Continuous Monitor Comment: 40 CFR 60, Subpart Cb, Monitor manufacturer and model number may vary for maintenance purposes.	

EMISSIONS UNIT INFORMATION

Section [1]

MSW Combustor & Auxiliary Burners: Units 1, 2, and 3

I. EMISSIONS UNIT ADDITIONAL INFORMATION

Additional Requirements for All Applications, Except as Otherwise Stated

1. Process Flow Diagram: (Required for all permit applications, except Title V air operation permit revision applications if this information was submitted to the department within the previous five years and would not be altered as a result of the revision being sought) <input checked="" type="checkbox"/> Attached, Document ID: <u>WNB-EU1-11</u> <input type="checkbox"/> Previously Submitted, Date _____
2. Fuel Analysis or Specification: (Required for all permit applications, except Title V air operation permit revision applications if this information was submitted to the department within the previous five years and would not be altered as a result of the revision being sought) <input checked="" type="checkbox"/> Attached, Document ID: <u>WNB-EU1-12</u> <input type="checkbox"/> Previously Submitted, Date _____
3. Detailed Description of Control Equipment: (Required for all permit applications, except Title V air operation permit revision applications if this information was submitted to the department within the previous five years and would not be altered as a result of the revision being sought) <input checked="" type="checkbox"/> Attached, Document ID: <u>WNB-EU1-13</u> <input type="checkbox"/> Previously Submitted, Date _____
4. Procedures for Startup and Shutdown: (Required for all operation permit applications, except Title V air operation permit revision applications if this information was submitted to the department within the previous five years and would not be altered as a result of the revision being sought) <input checked="" type="checkbox"/> Attached, Document ID: <u>WNB-EU1-14</u> <input type="checkbox"/> Previously Submitted, Date _____ <input type="checkbox"/> Not Applicable (construction application)
5. Operation and Maintenance Plan: (Required for all permit applications, except Title V air operation permit revision applications if this information was submitted to the department within the previous five years and would not be altered as a result of the revision being sought) <input checked="" type="checkbox"/> Attached, Document ID: <u>WNB-EU1-15</u> <input type="checkbox"/> Previously Submitted, Date _____ <input type="checkbox"/> Not Applicable
6. Compliance Demonstration Reports/Records: <input type="checkbox"/> Attached, Document ID: _____ Test Date(s)/Pollutant(s) Tested: _____ <input checked="" type="checkbox"/> Previously Submitted, Date: <u>April 27, 2010</u> Test Date(s)/Pollutant(s) Tested: <u>PM, VE, F, PCCD/PCDF, HCl, Be, Ca, Pb, Hg</u> <input type="checkbox"/> To be Submitted, Date (if known): _____ Test Date(s)/Pollutant(s) Tested: _____ <input type="checkbox"/> Not Applicable Note: For FESOP applications, all required compliance demonstration records/reports must be submitted at the time of application. For Title V air operation permit applications, all required compliance demonstration reports/records must be submitted at the time of application, or a compliance plan must be submitted at the time of application.
7. Other Information Required by Rule or Statute: <input type="checkbox"/> Attached, Document ID: _____ <input checked="" type="checkbox"/> Not Applicable

EMISSIONS UNIT INFORMATION

Section [1]

MSW Combustor & Auxiliary Burners: Units 1, 2, and 3

I. EMISSIONS UNIT ADDITIONAL INFORMATION (CONTINUED)

Additional Requirements for Air Construction Permit Applications

1. Control Technology Review and Analysis (Rules 62-212.400(10) and 62-212.500(7), F.A.C.; 40 CFR 63.43(d) and (e): <input type="checkbox"/> Attached, Document ID: _____ <input type="checkbox"/> Not Applicable
2. Good Engineering Practice Stack Height Analysis (Rules 62-212.400(4)(d) and 62-212.500(4)(f), F.A.C.): <input type="checkbox"/> Attached, Document ID: _____ <input type="checkbox"/> Not Applicable
3. Description of Stack Sampling Facilities: (Required for proposed new stack sampling facilities only) <input type="checkbox"/> Attached, Document ID: _____ <input type="checkbox"/> Not Applicable

Additional Requirements for Title V Air Operation Permit Applications

1. Identification of Applicable Requirements: <input checked="" type="checkbox"/> Attached, Document ID: WNB-EU1-IV1
2. Compliance Assurance Monitoring: <input type="checkbox"/> Attached, Document ID: _____ <input checked="" type="checkbox"/> Not Applicable
3. Alternative Methods of Operation: <input checked="" type="checkbox"/> Attached, Document ID: WNB-EU1-IV3 <input type="checkbox"/> Not Applicable
4. Alternative Modes of Operation (Emissions Trading): <input type="checkbox"/> Attached, Document ID: _____ <input checked="" type="checkbox"/> Not Applicable

Additional Requirements Comment

ATTACHMENT WNB-EU1-I1

PROCESS FLOW DIAGRAM

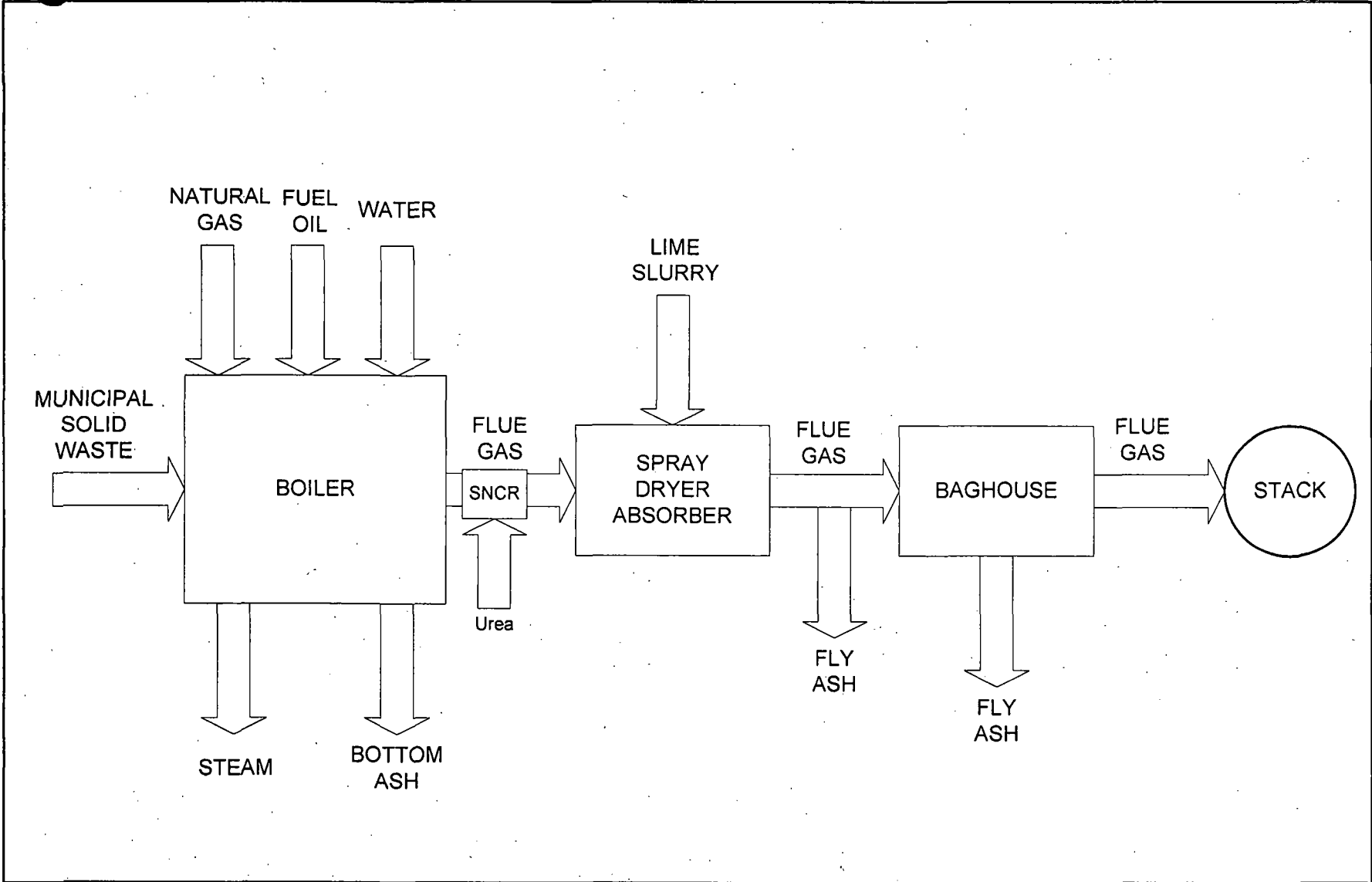

Attachment WNB-EU1-11
Process Flow Diagram - Typical of all Three Boilers (Nos. 1, 2, and 3)
Wheelabrator North Broward, Pompano Beach, Florida

Filename: WNB-EU1-11.VSD
Date: 06/23/10



ATTACHMENT WNB-EU1-I2
FUEL ANALYSIS OR SPECIFICATION



Florida Gas Transmission

Total Sulfur Previous Day

05/19/2010 12:00 PM

Florida Gas makes no warranty or representation whatsoever as to the accuracy of the information provided. This information is provided on a best efforts basis and is an estimate. The information is not used for billing purposes. Florida Gas is not responsible for any reliance on this information by any party.

Stream History

Gas Day	Perry 36" Stream #1		Perry 30" Stream #2		Perry 24" Stream #3		Brooker 24" Stream	
	Avg ppm	Avg Grains/hcf	Avg ppm	Avg Grains/hcf	Avg ppm	Avg Grains/hcf	Avg ppm	Avg Grains/hcf
05/18/2010	0.850	0.053	0.854	0.053	0.857	0.054	3.502	0.219
05/17/2010	0.876	0.055	1.231	0.077	1.259	0.079	3.696	0.231
05/16/2010	0.853	0.053	1.750	0.109	1.793	0.112	3.990	0.249
05/15/2010	0.811	0.051	1.668	0.104	1.673	0.105	3.811	0.238
05/14/2010	0.778	0.049	1.644	0.103	1.737	0.109	3.640	0.228
05/13/2010	0.772	0.048	1.331	0.083	1.343	0.084	3.240	0.202
05/12/2010	0.730	0.046	1.123	0.070	1.211	0.076	3.590	0.224
05/11/2010	0.766	0.048	1.444	0.090	1.442	0.090	3.520	0.220
05/10/2010	0.756	0.047	1.250	0.078	1.300	0.081	2.979	0.186
05/09/2010	0.698	0.044	1.110	0.069	1.108	0.069	2.938	0.184
05/08/2010	0.757	0.047	0.804	0.050	0.798	0.050	3.815	0.238
05/07/2010	0.717	0.045	0.752	0.047	0.759	0.047	3.844	0.240
05/06/2010	0.707	0.044	0.712	0.045	0.707	0.044	3.852	0.241
05/05/2010	0.663	0.041	0.587	0.037	0.585	0.037	3.517	0.220
05/04/2010	0.670	0.042	0.668	0.042	0.673	0.042	3.501	0.219
05/03/2010	0.763	0.048	0.726	0.045	0.721	0.045	3.801	0.238
05/02/2010	0.615	0.038	0.619	0.039	0.626	0.039	4.100	0.256
05/01/2010	0.829	0.052	0.740	0.046	0.748	0.047	3.871	0.242
04/30/2010	2.272	0.142	2.471	0.154	2.504	0.157	3.917	0.245
04/29/2010	1.147	0.072	1.332	0.083	1.361	0.085	4.028	0.252
04/28/2010	1.121	0.070	1.386	0.087	1.406	0.088	2.958	0.185
04/27/2010	1.071	0.067	1.257	0.079	1.243	0.078	3.112	0.195
04/26/2010	0.977	0.061	1.165	0.073	1.175	0.073	3.433	0.215
04/25/2010	0.845	0.053	0.913	0.057	0.921	0.058	2.580	0.161
04/24/2010	0.533	0.033	0.481	0.030	0.488	0.030	3.008	0.188
04/23/2010	0.592	0.037	0.676	0.042	0.694	0.043	3.392	0.212
04/22/2010	0.571	0.036	0.896	0.056	0.906	0.057	3.188	0.199
04/21/2010	0.577	0.036	0.908	0.057	0.934	0.058	3.239	0.202
04/20/2010	0.552	0.035	0.886	0.055	0.921	0.058	2.923	0.183
04/19/2010	0.577	0.036	0.847	0.053	0.884	0.055	2.091	0.131
04/18/2010	0.578	0.036	1.026	0.064	1.063	0.066	0.028	0.002
04/17/2010	0.708	0.044	1.248	0.078	1.259	0.079	0.029	0.002
04/16/2010	0.653	0.041	1.049	0.066	1.096	0.068	0.024	0.002
04/15/2010	0.656	0.041	1.222	0.076	1.254	0.078	0.284	0.018
04/14/2010	0.653	0.041	1.160	0.073	1.210	0.076	3.277	0.205
04/13/2010	0.689	0.043	1.217	0.076	1.262	0.079	3.500	0.219
04/12/2010	0.671	0.042	1.422	0.089	1.421	0.089	3.569	0.223
04/11/2010	0.663	0.041	1.149	0.072	1.190	0.074	3.569	0.223
04/10/2010	0.671	0.042	1.420	0.089	1.421	0.089	3.569	0.223
04/09/2010	0.718	0.045	1.316	0.082	1.327	0.083	3.569	0.223



Florida Gas Transmission

Total Sulfur Previous Day

05/19/2010 12:00 PM

Gas Day	Perry 36" Stream #1		Perry 30" Stream #2		Perry 24" Stream #3		Brooker 24" Stream	
	Avg ppm	Avg Grains/hcf	Avg ppm	Avg Grains/hcf	Avg ppm	Avg Grains/hcf	Avg ppm	Avg Grains/hcf
04/08/2010	0.623	0.039	0.892	0.056	0.893	0.056	3.569	0.223
04/07/2010	0.525	0.033	0.928	0.058	0.934	0.058	3.569	0.223
04/06/2010	0.521	0.033	1.072	0.067	1.117	0.070	3.569	0.223
04/05/2010	0.528	0.033	1.058	0.066	1.077	0.067	2.952	0.184
04/04/2010	0.503	0.031	0.932	0.058	0.941	0.059	1.269	0.079
04/03/2010	0.528	0.033	1.168	0.073	1.197	0.075	1.508	0.094
04/02/2010	0.598	0.037	1.291	0.081	1.300	0.081	1.540	0.096
04/01/2010	0.602	0.038	1.114	0.070	1.126	0.070	1.311	0.082
03/31/2010	0.561	0.035	1.524	0.095	1.542	0.096	1.486	0.093
03/30/2010	0.604	0.038	2.094	0.131	2.261	0.141	1.874	0.117
03/29/2010	0.532	0.033	1.742	0.109	1.741	0.109	2.207	0.138
03/27/2010	0.780	0.049	1.080	0.068	1.104	0.069	2.809	0.176
03/26/2010	0.821	0.051	0.993	0.062	1.008	0.063	3.019	0.189
03/25/2010	0.693	0.043	1.295	0.081	1.334	0.083	3.183	0.199
03/24/2010	0.639	0.040	1.165	0.073	1.187	0.074	2.955	0.185
03/23/2010	0.648	0.041	1.268	0.079	1.289	0.081	2.934	0.183
03/22/2010	0.634	0.040	1.383	0.086	1.419	0.089	2.938	0.184
03/21/2010	0.589	0.037	1.237	0.077	1.255	0.078	2.980	0.186
03/20/2010	0.629	0.039	1.199	0.075	1.220	0.076	3.387	0.212
03/19/2010	0.640	0.040	1.218	0.076	1.243	0.078	3.192	0.199
03/18/2010	0.698	0.044	1.488	0.093	1.527	0.095	3.094	0.193
03/17/2010	0.635	0.040	1.546	0.097	1.593	0.100	2.899	0.181
03/16/2010	0.671	0.042	1.640	0.103	1.649	0.103	2.713	0.170
03/15/2010	0.659	0.041	1.654	0.103	1.722	0.108	2.205	0.138
03/14/2010	0.636	0.040	1.487	0.093	1.501	0.094	0.029	0.002
03/13/2010	0.695	0.043	1.597	0.100	1.635	0.102	0.031	0.002
03/12/2010	0.711	0.044	1.316	0.082	1.335	0.083	1.715	0.107
03/11/2010	0.786	0.049	1.474	0.092	1.507	0.094	3.259	0.204
03/10/2010	0.850	0.053	1.391	0.087	1.416	0.088	3.332	0.208
03/09/2010	0.865	0.054	1.500	0.094	1.537	0.096	3.590	0.224
03/08/2010	0.827	0.052	1.113	0.070	1.245	0.078	3.483	0.218
03/07/2010	0.832	0.052	1.163	0.073	1.240	0.077	2.158	0.135
03/06/2010	0.831	0.052	1.232	0.077	1.245	0.078	2.065	0.129
03/05/2010	0.893	0.056	1.217	0.076	1.230	0.077	1.294	0.081
03/04/2010	0.810	0.051	1.201	0.075	1.223	0.076	1.767	0.110
03/03/2010	0.729	0.046	1.040	0.065	1.121	0.070	1.887	0.118
03/02/2010	0.675	0.042	1.043	0.065	1.109	0.069	2.382	0.149
03/01/2010	0.734	0.046	1.169	0.073	1.162	0.073	2.259	0.141
02/28/2010	0.705	0.044	1.060	0.066	1.076	0.067	2.068	0.129
02/27/2010	0.732	0.046	1.036	0.065	1.055	0.066	1.920	0.120
02/26/2010	0.803	0.050	1.051	0.066	1.062	0.066	1.896	0.119
02/25/2010	0.721	0.045	1.074	0.067	1.086	0.068	1.803	0.113
02/24/2010	0.594	0.037	1.153	0.072	1.170	0.073	2.271	0.142
02/23/2010	0.575	0.036	1.316	0.082	1.332	0.083	2.798	0.175
02/22/2010	0.502	0.031	1.136	0.071	1.158	0.072	2.829	0.177
02/21/2010	0.671	0.042	1.135	0.071	1.143	0.071	2.662	0.166



Florida Gas Transmission

Total Sulfur Previous Day 05/19/2010 12:00 PM

Gas Day	Perry 36" Stream #1		Perry 30" Stream #2		Perry 24" Stream #3		Brooker 24" Stream	
	Avg ppm	Avg Grains/hcf	Avg ppm	Avg Grains/hcf	Avg ppm	Avg Grains/hcf	Avg ppm	Avg Grains/hcf
02/20/2010	0.753	0.047	1.179	0.074	1.200	0.075	2.720	0.170
02/19/2010	0.795	0.050	1.198	0.075	1.210	0.076	2.331	0.146
02/18/2010	0.772	0.048	1.130	0.071	1.141	0.071	2.129	0.133
02/17/2010	0.829	0.052	1.099	0.069	1.114	0.070	2.051	0.128
02/16/2010	0.780	0.049	1.293	0.081	1.313	0.082	2.025	0.127
02/15/2010	0.754	0.047	1.075	0.067	1.082	0.068	1.783	0.111
02/14/2010	0.684	0.043	0.641	0.040	0.655	0.041	1.915	0.120
02/13/2010	0.643	0.040	0.654	0.041	0.666	0.042	1.733	0.108

Florida Gas Transmission Company, LLC

Date Requested: May 19 2010 1

The data contained herein is preliminary data and therefore should be used for contemporaneous operational purposes on subject to change at month end. This data is provided to assist our customers in tracking their gas usage as closely as possible. The information contained on this web page is not to be considered billable information. This data will be subject to verification and possible modification prior to billing. Florida Gas is not responsible for any reliance on this information by a

FGT Chromatograph By Id

Chromatograph Name: 8032 - WEST PALM

[download -- tab-delimited file](#)

Date	BTU	CO2	N2	Grav	Methan	Ethane	Propan	Ibutan	Nbutan	Ipenta	Npenta	C6	C7	C8	C
05/18/2010	1021	1.132	0.486	0.582	96.069	1.918	0.243	0.048	0.047	0.018	0.011	0.028	0.000	0.000	0
05/17/2010	1021	1.102	0.481	0.582	96.135	1.895	0.238	0.047	0.046	0.018	0.011	0.028	0.000	0.000	0
05/16/2010	1021	1.122	0.470	0.582	96.095	1.910	0.240	0.050	0.049	0.020	0.013	0.031	0.000	0.000	0
05/15/2010	1022	1.137	0.475	0.583	95.932	2.018	0.266	0.054	0.052	0.020	0.013	0.030	0.000	0.000	0
05/14/2010	1020	1.138	0.478	0.582	96.108	1.894	0.232	0.047	0.045	0.019	0.011	0.028	0.000	0.000	0
05/13/2010	1020	1.119	0.467	0.582	96.193	1.837	0.229	0.048	0.046	0.020	0.012	0.030	0.000	0.000	0
05/12/2010	1020	1.095	0.456	0.581	96.270	1.791	0.233	0.049	0.047	0.019	0.011	0.028	0.000	0.000	0
05/11/2010	1020	1.093	0.444	0.581	96.305	1.771	0.232	0.049	0.046	0.019	0.012	0.029	0.000	0.000	0
05/10/2010	1021	1.038	0.428	0.580	96.397	1.743	0.238	0.051	0.047	0.019	0.011	0.028	0.000	0.000	0
05/09/2010	1022	1.080	0.427	0.582	96.196	1.851	0.270	0.058	0.055	0.021	0.012	0.029	0.000	0.000	0
05/08/2010	1024	1.028	0.419	0.582	96.162	1.902	0.301	0.065	0.062	0.022	0.012	0.027	0.000	0.000	0
05/07/2010	1028	0.880	0.368	0.582	96.182	2.018	0.347	0.075	0.070	0.024	0.012	0.024	0.000	0.000	0
05/06/2010	1026	0.910	0.382	0.581	96.238	1.958	0.323	0.069	0.065	0.022	0.011	0.022	0.000	0.000	0
05/05/2010	1027	0.887	0.366	0.581	96.240	1.959	0.339	0.075	0.071	0.025	0.013	0.026	0.000	0.000	0
05/04/2010	1026	0.882	0.359	0.581	96.337	1.905	0.319	0.070	0.067	0.023	0.012	0.025	0.000	0.000	0
05/03/2010	1024	0.874	0.361	0.579	96.569	1.764	0.268	0.058	0.056	0.020	0.010	0.020	0.000	0.000	0
05/02/2010	1023	1.005	0.404	0.581	96.351	1.801	0.270	0.058	0.055	0.020	0.011	0.024	0.000	0.000	0
05/01/2010	1020	1.110	0.441	0.581	96.312	1.748	0.233	0.052	0.048	0.019	0.012	0.025	0.000	0.000	0
04/30/2010	1020	1.063	0.428	0.580	96.402	1.718	0.238	0.051	0.047	0.018	0.011	0.024	0.000	0.000	0
04/29/2010	1021	1.078	0.428	0.581	96.367	1.730	0.241	0.052	0.049	0.019	0.011	0.025	0.000	0.000	0
04/28/2010	1021	1.013	0.433	0.579	96.467	1.723	0.223	0.048	0.045	0.017	0.010	0.021	0.000	0.000	0
04/27/2010	1021	1.029	0.404	0.580	96.401	1.777	0.241	0.052	0.048	0.018	0.010	0.020	0.000	0.000	0
04/26/2010	1021	0.924	0.386	0.580	96.423	1.818	0.278	0.063	0.057	0.020	0.010	0.021	0.000	0.000	0
04/25/2010	1021	0.980	0.436	0.579	96.452	1.748	0.237	0.052	0.048	0.017	0.009	0.021	0.000	0.000	0
04/24/2010	1021	0.958	0.456	0.580	96.292	1.893	0.251	0.052	0.049	0.018	0.010	0.021	0.000	0.000	0
04/23/2010	1021	0.866	0.422	0.579	96.369	1.949	0.255	0.049	0.046	0.016	0.009	0.019	0.000	0.000	0
04/22/2010	1021	0.884	0.439	0.579	96.405	1.908	0.234	0.044	0.043	0.015	0.009	0.019	0.000	0.000	0
04/21/2010	1021	0.966	0.457	0.580	96.362	1.863	0.219	0.043	0.042	0.016	0.010	0.022	0.000	0.000	0
04/20/2010	1021	0.996	0.482	0.580	96.263	1.897	0.225	0.044	0.044	0.017	0.010	0.022	0.000	0.000	0
04/19/2010	1021	0.979	0.470	0.580	96.366	1.828	0.228	0.042	0.041	0.015	0.009	0.021	0.000	0.000	0
04/18/2010	1020	0.949	0.454	0.579	96.459	1.815	0.212	0.037	0.037	0.013	0.008	0.017	0.000	0.000	0
04/17/2010	1019	0.968	0.430	0.578	96.560	1.738	0.199	0.035	0.034	0.012	0.007	0.016	0.000	0.000	0
04/16/2010	1019	0.980	0.433	0.578	96.596	1.683	0.198	0.036	0.035	0.013	0.008	0.018	0.000	0.000	0
04/15/2010	1020	0.978	0.444	0.579	96.434	1.825	0.205	0.037	0.037	0.013	0.008	0.018	0.000	0.000	0
04/14/2010	1020	0.948	0.461	0.578	96.524	1.761	0.198	0.035	0.034	0.013	0.008	0.018	0.000	0.000	0
04/13/2010	1020	1.000	0.442	0.579	96.449	1.757	0.214	0.043	0.042	0.017	0.011	0.024	0.000	0.000	0
04/12/2010	1020	0.984	0.462	0.579	96.429	1.802	0.205	0.038	0.038	0.014	0.009	0.020	0.000	0.000	0
04/11/2010	1020	0.981	0.446	0.579	96.519	1.726	0.211	0.039	0.038	0.014	0.008	0.019	0.000	0.000	0
04/10/2010	1020	0.938	0.449	0.578	96.594	1.700	0.205	0.037	0.037	0.013	0.008	0.018	0.000	0.000	0
04/09/2010	1021	0.903	0.442	0.578	96.565	1.763	0.210	0.040	0.038	0.014	0.008	0.018	0.000	0.000	0
04/08/2010	1020	0.890	0.408	0.577	96.777	1.621	0.196	0.036	0.035	0.012	0.008	0.017	0.000	0.000	0
04/07/2010	1022	0.880	0.435	0.579	96.482	1.825	0.245	0.045	0.043	0.015	0.009	0.021	0.000	0.000	0

04/06/2010	1023	0.853	0.426	0.579	96.474	1.870	0.249	0.046	0.042	0.014	0.008	0.018	0.000	0.000	0
04/05/2010	1021	0.959	0.437	0.579	96.452	1.815	0.214	0.041	0.039	0.014	0.009	0.020	0.000	0.000	0
04/04/2010	1021	1.023	0.458	0.580	96.302	1.861	0.224	0.043	0.040	0.016	0.010	0.023	0.000	0.000	0
04/03/2010	1022	1.000	0.440	0.580	96.237	1.977	0.222	0.040	0.038	0.015	0.009	0.022	0.000	0.000	0
04/02/2010	1020	1.004	0.445	0.579	96.455	1.785	0.195	0.036	0.035	0.014	0.009	0.021	0.000	0.000	0
04/01/2010	1019	1.012	0.436	0.579	96.577	1.652	0.197	0.040	0.038	0.015	0.010	0.023	0.000	0.000	0
03/31/2010	1021	1.012	0.431	0.580	96.381	1.795	0.231	0.049	0.045	0.018	0.011	0.027	0.000	0.000	0
03/30/2010	1022	1.014	0.414	0.581	96.319	1.833	0.254	0.055	0.050	0.020	0.012	0.028	0.000	0.000	0
03/29/2010	1020	0.979	0.383	0.578	96.691	1.621	0.200	0.041	0.039	0.016	0.009	0.022	0.000	0.000	0
03/28/2010	1020	0.979	0.383	0.578	96.691	1.621	0.200	0.041	0.039	0.016	0.009	0.022	0.000	0.000	0
03/27/2010	1019	0.982	0.404	0.578	96.653	1.655	0.188	0.037	0.036	0.014	0.009	0.021	0.000	0.000	0
03/26/2010	1019	0.972	0.413	0.578	96.696	1.624	0.181	0.036	0.035	0.014	0.009	0.020	0.000	0.000	0
03/25/2010	1019	0.929	0.419	0.577	96.751	1.606	0.181	0.035	0.035	0.014	0.009	0.021	0.000	0.000	0
03/24/2010	1019	0.917	0.431	0.577	96.685	1.669	0.188	0.035	0.034	0.014	0.008	0.020	0.000	0.000	0
03/23/2010	1019	0.978	0.415	0.578	96.683	1.618	0.188	0.036	0.036	0.015	0.009	0.021	0.000	0.000	0
03/22/2010	1018	0.995	0.433	0.578	96.663	1.611	0.185	0.035	0.035	0.014	0.009	0.021	0.000	0.000	0
03/21/2010	1019	0.972	0.434	0.578	96.593	1.699	0.186	0.035	0.036	0.014	0.009	0.022	0.000	0.000	0
03/20/2010	1021	0.997	0.433	0.580	96.383	1.829	0.217	0.042	0.044	0.017	0.011	0.026	0.000	0.000	0
03/19/2010	1021	0.978	0.421	0.579	96.511	1.734	0.214	0.043	0.045	0.018	0.011	0.025	0.000	0.000	0
03/18/2010	1020	0.977	0.442	0.579	96.519	1.753	0.190	0.037	0.037	0.015	0.009	0.021	0.000	0.000	0
03/17/2010	1020	1.002	0.426	0.579	96.537	1.695	0.212	0.039	0.041	0.015	0.009	0.021	0.000	0.000	0
03/16/2010	1021	1.012	0.419	0.580	96.419	1.775	0.233	0.045	0.047	0.016	0.010	0.023	0.000	0.000	0
03/15/2010	1023	1.026	0.435	0.581	96.209	1.868	0.288	0.054	0.059	0.020	0.013	0.028	0.000	0.000	0
03/14/2010	1022	1.013	0.428	0.581	96.339	1.768	0.286	0.052	0.058	0.019	0.012	0.025	0.000	0.000	0
03/13/2010	1020	1.040	0.435	0.580	96.437	1.686	0.250	0.047	0.051	0.018	0.012	0.024	0.000	0.000	0
03/12/2010	1020	1.047	0.426	0.580	96.503	1.627	0.242	0.047	0.051	0.019	0.012	0.025	0.000	0.000	0
03/11/2010	1020	1.040	0.418	0.580	96.495	1.634	0.253	0.049	0.054	0.020	0.013	0.025	0.000	0.000	0
03/10/2010	1021	1.059	0.430	0.581	96.353	1.721	0.265	0.052	0.059	0.021	0.013	0.028	0.000	0.000	0
03/09/2010	1024	1.010	0.432	0.582	96.215	1.863	0.295	0.056	0.065	0.021	0.014	0.029	0.000	0.000	0
03/08/2010	1023	1.015	0.447	0.582	96.206	1.849	0.302	0.056	0.064	0.021	0.014	0.027	0.000	0.000	0
03/07/2010	1026	0.951	0.393	0.582	96.222	1.910	0.327	0.063	0.070	0.023	0.015	0.027	0.000	0.000	0
03/06/2010	1026	0.951	0.393	0.582	96.222	1.910	0.327	0.063	0.070	0.023	0.015	0.027	0.000	0.000	0
03/05/2010	1024	1.001	0.396	0.581	96.246	1.885	0.290	0.057	0.064	0.021	0.013	0.026	0.000	0.000	0
03/04/2010	1022	1.003	0.396	0.580	96.396	1.805	0.250	0.047	0.051	0.018	0.011	0.024	0.000	0.000	0
03/03/2010	1021	1.071	0.437	0.581	96.220	1.874	0.247	0.046	0.049	0.018	0.011	0.026	0.000	0.000	0
03/02/2010	1022	1.088	0.432	0.582	96.123	1.932	0.269	0.050	0.051	0.018	0.011	0.026	0.000	0.000	0
03/01/2010	1022	1.073	0.426	0.581	96.206	1.909	0.235	0.048	0.048	0.018	0.011	0.025	0.000	0.000	0
02/28/2010	1025	0.965	0.396	0.581	96.203	1.964	0.303	0.059	0.059	0.019	0.011	0.021	0.000	0.000	0
02/27/2010	1023	0.996	0.395	0.581	96.306	1.839	0.293	0.056	0.058	0.020	0.012	0.024	0.000	0.000	0
02/26/2010	1021	1.036	0.412	0.580	96.428	1.716	0.254	0.047	0.052	0.018	0.012	0.025	0.000	0.000	0
02/25/2010	1022	0.973	0.423	0.580	96.423	1.767	0.267	0.044	0.053	0.017	0.011	0.022	0.000	0.000	0
02/24/2010	1022	0.911	0.415	0.579	96.543	1.695	0.285	0.046	0.055	0.017	0.011	0.022	0.000	0.000	0
02/23/2010	1022	0.978	0.428	0.580	96.418	1.753	0.269	0.047	0.054	0.018	0.012	0.024	0.000	0.000	0
02/22/2010	1021	1.035	0.435	0.580	96.335	1.799	0.247	0.045	0.050	0.018	0.011	0.025	0.000	0.000	0
02/21/2010	1022	1.061	0.441	0.581	96.210	1.879	0.256	0.047	0.050	0.019	0.012	0.026	0.000	0.000	0
02/20/2010	1021	1.076	0.451	0.581	96.221	1.831	0.259	0.049	0.053	0.020	0.013	0.028	0.000	0.000	0
02/19/2010	1022	1.096	0.459	0.582	96.110	1.899	0.269	0.050	0.054	0.021	0.013	0.029	0.000	0.000	0
02/18/2010	1021	1.113	0.467	0.582	96.099	1.911	0.256	0.047	0.050	0.019	0.012	0.026	0.000	0.000	0

ATTACHMENT WNB-EU1-I3

DETAILED DESCRIPTION OF CONTROL EQUIPMENT

ATTACHMENT WNB-EU1-I3A
DETAILED DESCRIPTION OF CONTROL EQUIPMENT
SPRAY DRYER ABSORBER

Flue gas enters the top of the Spray Dryer Absorber (SDA) through a diverging cone section and into the vessel. A total of three, multiple port two-fluid nozzles spray the atomized slurry down the center of the vessel, parallel to the gas flow. The flue gas and the evaporating slurry droplets pass down the vessel to the hopper. The flue gas makes a 90 degree turn and exits the SDA and enters the Fabric Filter (FF). Some of the entrained flyash and dried reaction products fall out of the flue gas and are discharged from the SDA hopper.

The SDA is designed to provide 10 seconds flue gas residence time based on the design gas flow rate.

Gas Distribution

Flue gas enters the top of the SDA and passes through a distribution section to evenly distribute the flue gas across the spray dryer absorber cross section at the slurry injection point. The flue gas elbow above the SDA utilizes turning vanes. The flue gas distribution section consists of two banks of chevrons. The turning vanes and chevrons are constructed of abrasion-resistant steel.

Atomizing Nozzles

The SDA is provided with three multiple port two-fluid nozzles. Each two-fluid nozzle consists of a stainless-steel (630) head with multiple, ceramic two-fluid nozzle inserts. Each nozzle is provided with a supporting lance assembly consisting of a structural tube and an aerodynamic shroud. The lance firmly positions the nozzle in the dryer and the shroud minimizes the external buildup of ash on the nozzle. The nozzle assembly is flange mounted on the SDA and has quick disconnects for slurry, dilution water and compressed air.

The SDA operates using three nozzle heads, each with nine ceramic inserts.

SDA Process Control

The main control loops for the SDA are total slurry feed control and the control of the mixture of concentrated lime slurry and dilution water, which is designed to maintain the guaranteed sulfur dioxide (SO₂) emission limits.

Atomizing air flow is controlled using a flow controller utilizing Flow Control Valve based on a feed back signal from a flow transmitter.

ATTACHMENT WNB-EU1-I3B
DETAILED DESCRIPTION OF CONTROL EQUIPMENT
FABRIC FILTER

The fabric filter (FF) uses a combination of very low reverse gas or deflation air to clean the bags followed by a brief period of mechanical shaking.

Shake deflate cleaning uses a very low velocity, short duration reverse gas flow only to relax the bag. This is followed by a mechanical shake period. Each shake sends a wave down the bag, flexing the built up filter cake, cracking it, and accelerating it off the bag. Fifteen to fifty oscillations are sent through the bag.

Each bag in a shake deflate FF is mechanically attached to the shaker, assuring cleaning.

Shake Deflate Cleaning Sequence

The cleaning sequence is initiated based on pressure drop or a timer override. The compartment is isolated by closing the outlet damper, allowing the compartment to settle. The deflation air damper is opened, the recirculation damper is closed, gently deflating the bags. The deflation and recirculation dampers are then reversed allowing another settle period. The shaker mechanism is then activated. Another, much longer settle period occurs, allowing the dust to settle into the hopper. The compartment is then brought back on line, first re-inflating the bags, then bringing them completely on line.

ATTACHMENT WNB-EU1-I4

STARTUP AND SHUTDOWN PROCEDURES

ATTACHMENT WNB-EU1-I4 STARTUP AND SHUTDOWN PROCEDURE

MWC Unit Startup Procedure

Note: Shift Supervisor will communicate with the Maintenance Department as repairs are nearing completion. Operations will conduct a prelight-off walk down, insuring boiler is ready for light off. The walk down should be completed just before boiler is released to the Operations Department.

1. Insure all personal and contractor locks are removed from the lockbox and that conditions are safe to proceed with boiler warm-up. Remove equipment locks from the fans and gas-burners and begin the warm-up (see steps 2 – 8). Remove the remaining outstanding clearances. Insure valve line-up is correct.
2. Put ID fan into service, in AUTO with set point -.1
3. Start-up hydraulics: grates ram feeder and expellers at normal speeds. Run flaggate pump to close arch breaker, then secure it.
4. Verify unit CEMS is in service.
5. Insure correct water level in steam drum, about a minus 2" level or so. Fill boiler if necessary via cold fill from demineralized water system pumps if within 100 deg F. of metal temperature or via feedwater station if metal temperature is higher.
6. With dampers shut in manual, put FD fans into service (restart grates). Start secondary air fan. Start bringing airflows up. You need approximately 33,000 cfm total air flow for a gas burner purge permissive. You want PA duct pressure of 16 inches and SA duct pressure of 30 inches. To get enough air flow you'll want PA combustion zone dampers (zones 2 & 3) about 20 to 30% open and SA front and rear wall dampers around 40 to 60% open.
7. Put one set of gas burners in service, leave at minimum set point.
8. Put second set of gas burners in service, then secure primary air fan and insure grates are running. Set secondary front and rear dampers around 15 to 20% open. This allows some convection through the boiler and bag house but not too much cold air.
9. It should take about 5 hours to heat up a cold boiler. Do not exceed boiler metal temperatures more than 100 degrees F. per hour or 150 degrees F. differential between top and bottom drum metal temperatures.
10. At 25 to 40 psi drum pressure, verify secondary superheater drain is open about two turns and close all vents and other drains. Blow down water walls at 100 psi.
11. Start the chemical feed pump and line-up continuous blow down after boiler is on line.

12. You will need to blow down the boiler from time to time during the heat up. However, you will reach a point where drum level holds steady and then starts to decrease (usually approximately 600 psi). At this time the feedwater regulating valve should be lined up with drum level control in "start-up" mode on Bailey (set pt. 0 inches).
13. Put PA fan back in service, leave dampers shut, restart grates and put one bank of SCAH's in service.
14. You are firing the temperature, pressure will follow. At approximately 750-psi, initiate operation of ERV to hold pressure and allow final steam temperature to rise. Ideally this should be in excess of 750 degrees F. This could be difficult to achieve on gas. A technique of "burping" the ERV a few times may help. Burping is when you rapidly open the ERV to about 40 to 50%. When drum level starts rising, ramp the ERV back closed. The final steam temperature will drop rapidly due to slugs of water being moved through it. When temperature comes back up, burp it again. Continue until steam temperature does not drop or drops only slightly.
15. NOTE: When fabric filter inlet temperature gets into the low 300's it will be time to get SDA lances into operation.
16. Open main steam stop. Put remaining SCAH's in service.
17. Load feed hopper with dry trash, (two grapples with a third ready to go in.)
18. Set up combustion profile
 - Boiler master in manual at 50%
 - Grates in AUTO, with bias -15.
 - Ram feeder at 100%, initially.
 - PA zone #1 damper at least 25%
 - Move SA, front and rear dampers to between 10 and 30%
19. Drop trash onto ram table by opening flap gate in 3 or 4 increments. Too much turbulence could blow out gas guns. Boiler is considered ON-LINE once trash is "dropped" (assuming ram feeder is running).
20. Close secondary S.H. drains and line up attemperator.
21. Monitor ignition of trash, CO and O₂ levels. As trash moves down grates, increase the air to each zone. Adjust ram feeder speed.
22. Monitor CO, O₂ and flames of trash line and adjust SA dampers as needed.

23. With a final steam temp of about 800 degrees F., begin adjusting ERV until shut to allow a smooth transition into the steam header and load increase onto the T/G.
24. As steam flow increases start backing gas down to min. and eventually take OOS.
25. With steam flow about 100k and increasing, put drum level mode to "normal" and begin to get air dampers into AUTO mode..
26. Recheck all combustion profile pages and adjust T/G IPC control set point.

Sign off

MWC Unit Shutdown Procedure

1. Stop feeding trash to the unit, close arch breaker (flap gate) when trash level drops below it.
2. Run rappers, then the sootblowers.
3. When trash is low in the feed chute, as evident by seeing flames in-between the flap gate panels, close flap gate and light off gas burners.
4. Monitor fire, steam flow, O₂, CO, and make adjustments on gas burners and air dampers to control O₂ and minimize CO.
5. When steam flow starts to dip, begin to increase ram feeder speed on up to 100%.
6. As trash bed thins out, increase grate speed to maximum, maintaining burnout to expellers.
7. When all trash is burnt out, take SCAHs out of service.
8. Back down gas burners to minimum and remove from service using the low water cut-off trip. Primary fan will trip and grates will shutdown.
9. Boiler is OFF-LINE once we stop the ram feeder, grates and all air fans, which is our active control of combustion.
10. Turn off secondary air fan. Open all primary and secondary dampers to about 100%. Restart grates to run out ash.
11. Begin to open flap gate wide as you monitor boiler draft and put ID fan in manual control. Speed up fan to approximately 75% but see what the bag house D/P will permit. Open boiler door on elevation 26' to pull heat out of the bottom of the furnace.

12. Open ERV to control cool down rate, 75 degrees F per hour metal temperature. See SHUT-DOWN CURVE. Run S.H. and generator rappers while cooling down. Raise drum water level set point to about + 8 inches.
13. Close non-return and main steam stop. Open boiler penthouse door and vents. Install air movers so that it pulls air out from inside the penthouse.
14. As drum pressure approaches 100-psig blows down sidewall drains.
15. Run SDA outlet temperature down to 270 degrees F. Once below that, shut down SDA feed and flush out piping. Clean bag house compartments from Bailey while still hot. Turn off deflation fan.
16. At about 25 psig open drum and S.H. vents and drains. Open ERV to 100% in manual; secure boiler chemical pump and feedwater station. Turn off rappers and grates.

Sign-Off

ATTACHMENT WNB-EU1-I5
OPERATION AND MAINTENANCE PLAN

ATTACHMENT WNB-EU1-I5 OPERATION AND MAINTENANCE PLAN

The Wheelabrator North Broward facility has an Operation and Maintenance (O&M) Plan that is available upon request at the facility. The O&M Plan includes the following:

- Summary of Applicable Standards
- Description of Basic Combustion Theory Applicable to a Municipal Waste Combustor Unit
- Procedures for Receiving, Handling and Feeding Municipal Solid Waste
- Municipal Waste Combustor Unit Start Up, Shut Down and Malfunction Procedures
- Procedures for Maintaining Proper Combustion Air Supply Levels
- Procedures for Operating the Municipal Waste Combustor Unit Within the Standards Established
- Procedures for Responding to Periodic Upset or Off-Specification Conditions
- Procedures for Minimizing Particulate Matter Carryover
- Procedures for Handling Ash
- Procedures for Monitoring Municipal Waste Combustor Unit Emissions
- Reporting and Recordkeeping Procedures

ATTACHMENT WNB-EU1-IV1

IDENTIFICATION OF APPLICABLE REQUIREMENTS

Wheelabrator North Broward, Inc.
North Broward Waste-to-Energy Facility
Facility ID No. 0112120
Broward County

FINAL Permit No. 0112120-009-AV

Permitting Authority

State of Florida
Department of Environmental Protection
Division of Air Resource Management
Bureau of Air Regulation
Permitting South Section

Mail Station #5505
2600 Blair Stone Road
Tallahassee, Florida 32399-2400
Telephone: 850/488-0114
Fax: 850/922-6979

Compliance Authority

State of Florida
Department of Environmental Protection
Southeast District Office
400 North Congress Avenue
West Palm Beach, Florida 33416-5425
Telephone: 561/681-6600
Fax: 561/681-6755

Title V Air Operation Permit Renewal

Permit No. 0112120-009-AV

Table of Contents

<u>Section</u>	<u>Page Number</u>
Title V Air Operation Permit Placard Page	1
I. Facility Information.....	2
A. Facility Description.....	2
B. Summary of Emissions Unit ID Numbers and Brief Descriptions.....	2
C. Relevant Documents.....	2
II. Facility-wide Conditions.....	4
III. Emissions Units and Conditions.....	7
A. [Reserved.].....	7
B. Municipal Waste Combustors After Retrofit.....	8
C. Material Handling Units.....	47
Appendix I-1, List of Insignificant Emissions Units and/or Activities.....	54

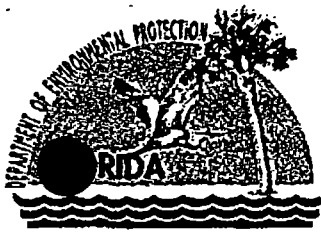

Department of Environmental Protection

Jeb Bush
Governor

Twin Towers Office Building
2600 Blair Stone Road
Tallahassee, Florida 32399-2400

Colleen M. Castille
Secretary

Permittee:
Wheelabrator North Broward, Inc.
2600 N.W. 48th Street
Pompano Beach, Florida 33073

FINAL Permit No. 0112120-009-AV
Facility ID No. 0112120
SIC Nos.: 49, 4953
Project: Title V Air Operation Permit Renewal

This facility is located at 2600 N.W. 48th Street, Pompano Beach, Broward County. UTM Coordinates: Zone 17, 583.541 km East and 2907.498 km North; Latitude: 26° 17' 12" North and Longitude: 80° 09' 48" West.

This Title V Air Operation Permit Renewal is issued under the provisions of Chapter 403, Florida Statutes (F.S.), and Florida Administrative Code (F.A.C.) Chapters 62-4, 62-210 and 62-213. The above named permittee is hereby authorized to operate the facility shown on the application and approved drawing(s), plans, and other documents, attached hereto or on file with the permitting authority, in accordance with the terms and conditions of this permit.

Referenced attachments made a part of this permit:

Appendix I-1, List of Insignificant Emissions Units and/or Activities
Appendix SS-1, Stack Sampling Facilities (version dated 10/7/96)
Appendix TV-5, TITLE V CONDITIONS (version dated 03/28/05)
Figure 1: Summary Report-Gaseous and Opacity Excess Emission and Monitoring System Performance (40 CFR 60)
Table 297.310-1, Calibration SCHEDULE (version dated 10/07/96)

Effective Date: February 14, 2006
Renewal Application Due Date: August 17, 2010
Expiration Date: February 13, 2011

Michael G. Cooke, Director
Division of Air Resource
Management

Section I. Facility Information.

Subsection A. Facility Description.

This facility consists of three municipal solid waste combustors (Unit Nos. 1, 2 and 3) with auxiliary burners, lime storage and processing facilities, ash storage and processing facilities, a cooling tower, and ancillary support equipment. The nominal (generator nameplate) electric generating capacity of the facility is 67.6 megawatts (MW), which is sold to the local utility. Also included in this permit are miscellaneous insignificant emissions units and/or activities.

Each of the combustor units at the facility includes an acid gas, air toxics, and particulate emissions control system consisting of a lime spray dryer and baghouse. Nitrogen oxides are controlled by a urea injection system that operates under the principle of selective non-catalytic reduction (SNCR). There is a metals recovery system which is a potential source of fugitive emissions.

Based on the Title V permit renewal application received on April 25, 2005, this facility is a major source of hazardous air pollutants (HAPs). The facility is subject to requirements of 40 CFR 60, Subpart Cb – Emissions Guidelines and Compliance Times for Large Municipal Waste Combustors That are Constructed on or Before September 20, 1994.

Subsection B. Summary of Emissions Unit ID Numbers and Brief Descriptions.

E.U. ID No.	Brief Description
-001	807 TPD (maximum) Municipal Waste Combustor & Auxiliary Burners - Unit 1
-002	807 TPD (maximum) Municipal Waste Combustor & Auxiliary Burners - Unit 2
-003	807 TPD (maximum) Municipal Waste Combustor & Auxiliary Burners - Unit 3
-004	236 Ton Lime Silo with Baghouse
-005	Ash Handling System
-006	Wet Scrubber in Ash Handling Building. (This scrubber has not been installed, but may be installed in the future should facility management deem it necessary for ash building indoor air quality control.)

Please reference the Permit Number, the Facility Identification Number, and the appropriate Emissions Unit(s) ID Number(s) on all correspondence, test report submittals, applications, etc.

Subsection C. Relevant Documents.

The documents listed below are not a part of this permit; however, they are specifically related to this permitting action.

These documents are provided to the permittee for informational purposes:

Table 1-1, Summary of Air Pollutant Standards and Terms

Table 2-1, Summary of Compliance Requirements

Appendix A-1: Abbreviations, Acronyms, Citations, and Identification Numbers

Appendix H-1: Permit History

Appendix BW, Biological Waste Definitions

Statement of Basis

These documents are on file with the permitting authority:

Application for Title V Air Operation Permit Renewal received on April 25, 2005.

Letter from the Department requesting additional information dated May 9, 2005.

Response from the Applicant in a letter received on August 18, 2005.

DRAFT Title V Air Operation Permit clerked on October 7, 2005.

E-mail memorandum from the Applicant received on November 10, 2005.

PROPOSED Title V Air Operation Permit posted for EPA review on December 21, 2005.

Section II. Facility-wide Conditions.

The following conditions apply facility-wide:

1. APPENDIX TV-5, TITLE V CONDITIONS, (version dated 03/28/05) is a part of this permit. {Permitting note: APPENDIX TV-5, TITLE V CONDITIONS, is distributed to the permittee only. Other persons requesting copies of these conditions shall be provided one copy when requested or otherwise appropriate.}

2. **Not federally enforceable.** General Pollutant Emission Limiting Standards. Objectionable Odor Prohibited. The permittee shall not cause, suffer, allow, or permit the discharge of air pollutants which cause or contribute to an objectionable odor.
[Rule 62-296.320(2), F.A.C.]

3. General Particulate Emission Limiting Standards. General Visible Emissions Standard. Except for emissions units that are subject to a particulate matter or opacity limit set forth or established by rule and reflected by conditions in this permit, no person shall cause, let, permit, suffer or allow to be discharged into the atmosphere the emissions of air pollutants from any activity, the density of which is equal to or greater than that designated as Number 1 on the Ringelmann Chart (20 percent opacity). EPA Method 9 is the method of compliance pursuant to Chapter 62-297, F.A.C.
[Rule 62-296.320(4)(b)1. & 4., F.A.C.]

4. Prevention of Accidental Releases (Section 112(r) of CAA).

a. The permittee shall submit its Risk Management Plan (RMP) to the Chemical Emergency Preparedness and Prevention Office (CEPPO) RMP Reporting Center when, and if, such requirement becomes applicable. Any Risk Management Plans, original submittals, revisions or updates to submittals, should be sent to:

RMP Reporting Center
Post Office Box 3346
Merrifield, VA 22116-3346
Telephone: 703/816-4434

and,

b. The permittee shall submit to the permitting authority Title V certification forms or a compliance schedule in accordance with Rule 62-213.440(2), F.A.C.
[40 CFR 68]

5. Insignificant Emissions Units and or Activities. Appendix I - List of insignificant emission units and/or activities, is a part of this permit. [Rules 62-213.440(1), 62-213.430 (6) and 62-4.040 (1)(b), F.A.C.]

6. **Not federally enforceable.** General Pollutant Emission Limiting Standards. Volatile Organic Compounds (VOC) Emissions or Organic Solvents (OS) Emissions. The permittee shall allow no person to store, pump, handle, process, load, unload or use in any process or installation, volatile organic compounds (VOC) or organic solvents (OS) without applying known and existing vapor emission control devices or systems deemed necessary and ordered by the Department.
{Permitting Note: No vapor emissions control devices or systems are deemed necessary nor ordered by the Department as of the issuance date of this permit.}
[Rule 62-296.320(1)(a), F.A.C.]

7. Emissions of Unconfined Particulate Matter. Pursuant to Rules 62-296.320(4)(c)1., 3. & 4., F.A.C., reasonable precautions to prevent emissions of unconfined particulate matter at this facility include the following requirements (see Condition 57. of APPENDIX TV-5, TITLE V CONDITIONS):

The following techniques will be used to prevent unconfined particulate matter emissions on as needed basis:

- a. Chemical or water application to:
 - Unpaved roads
 - Unpaved yard areas
- b. Paving and maintenance of roads, parking areas and yards.
- c. Removal of particulate matter from roads and other paved areas under the control of the owner or operator of the facility to prevent re-entrainment, and from buildings or work areas to prevent particulate matter from becoming airborne.
- c. Landscaping or planting of vegetation.
- d. Confining abrasive blasting where possible.
- e. Enclosure or covering of conveyer systems.
- f. Use of hoods, fans, filters, and similar equipment to contain, capture, and/or vent particulate matter.

[Rule 62-296.320(4)(c)2., F.A.C.; and requested by the Applicant in the renewal application received on April 25, 2005.]

8. Timely Recording, Monitoring and Reporting: When appropriate, any recording, monitoring, or reporting requirements that are time-specific shall be in accordance with the effective date of the permit, which defines day one.

[Rule 62-213.440, F.A.C.]

9. Statement of Compliance. The annual statement of compliance pursuant to Rule 62-213.440(3)(a)2., F.A.C., shall be submitted to the Department and EPA within 60 (sixty) days after the end of the calendar year using DEP Form No. 62-213.900(7), F.A.C.

[Rules 62-213.440(3) and 62-213.900, F.A.C.]

{Permitting Note: This condition implements the requirements of Rules 62-213.440(3)(a)2. & 3., F.A.C. (see Condition 51: of APPENDIX TV-5, TITLE V CONDITIONS)}

10. State Compliance Authority: The permittee shall submit all compliance related notifications and reports required of this permit to the Department's Southeast District office:

State of Florida
Department of Environmental Protection
Southeast District Office
400 North Congress Avenue
West Palm Beach, Florida 33416-5425
Telephone: 561/681-6600, Fax: 561/681-6755

11. EPA Compliance Authority: Any reports, data, notifications, certifications, and requests required to be sent to the United States Environmental Protection Agency, Region 4, should be sent to:

United States Environmental Protection Agency
Region 4
Air, Pesticides & Toxics Management Division
Air and EPCRA Enforcement Branch
Air Enforcement Section
61 Forsyth Street
Atlanta, Georgia 30303
Telephone: 404/562-9155, Fax: 404/562-9164

12. Certification by Responsible Official (RO). In addition to the professional engineering certification required for applications by Rule 62-4.050(3), F.A.C., any application form, report, compliance statement, compliance plan and compliance schedule submitted pursuant to Chapter 62-213, F.A.C., shall contain a certification signed by a responsible official that, based on information and belief formed after reasonable inquiry, the statements and information in the document are true, accurate, and complete. Any responsible official who fails to submit any required information or who has submitted incorrect information shall, upon becoming aware of such failure or incorrect submittal, promptly submit such supplementary information or correct information.
[Rule 62-213.420(4), F.A.C.]

Section III. Emissions Units and Conditions.

Subsection A. This section addresses the following emissions units.

[Reserved.]

Subsection B. This section addresses the following emissions units.

E.U. ID No.	Brief Description
-001	807 TPD (maximum) Municipal Waste Combustor & Auxiliary Burners - Unit 1
-002	807 TPD (maximum) Municipal Waste Combustor & Auxiliary Burners - Unit 2
-003	807 TPD (maximum) Municipal Waste Combustor & Auxiliary Burners - Unit 3

{Note: Each of the three municipal waste combustors (MWCs) has a *nominal* design rate capacity of 747 tons MSW per day and 280 MMBtu per hour heat input (with MSW having a heating value of 4,500 Btu per pound). A maximum (short-term) capacity of 807 tons of waste per day and 302.5 mmBtu per hour heat input (108% rated capacity) is allowed. Short-term capacity is limited by limiting steam production, which effectively limits heat input. The maximum steam production rate is 186,000 lbs/hr, with a net steam energy of 5,600 Btu/lb of steam (the net steam energy may be calculated as the difference in enthalpy between the steam at the superheater outlet and the feedwater at the inlet).

Emissions units numbers -001, -002 and -003 are Babcock and Wilcox manufactured municipal solid waste (MSW) combustors designated as "Unit 1", "Unit 2" and "Unit 3", respectively. Each unit consists of an integrated mass-burn furnace and multi-pass waterwall type boiler with a rated (nominal) capacity of 747 tons MSW per day (TPD) and 280 million British thermal units per hour (MMBtu/hr) heat input when burning solid waste with a heat content of 4,500 British thermal units per pound (Btu/lb). Therefore, the facility has a nameplate (nominal) waste processing rate of 2,241 TPD (4,500 Btu/lb). Two auxiliary distillate fuel oil or natural gas fired burners are associated with each MSW combustor. The burners are used to fire the MSW combustors during start-up, shutdown, and at other times when necessary and consistent with good combustion practices. The maximum permitted steam production rate of each unit is 186,000 lbs/hr when firing municipal solid waste. Steam flow is the main process throughput parameter to be monitored for these units.

Units 1, 2 and 3 began commercial operation June 13, June 23 and July 31, 1991, respectively. Particulate matter, some metals (Pb, Hg, Be), SO₂ and acid gas emissions from Units 1, 2 and 3 are controlled by separate baghouses and spray dry absorbers, while CO and NO_x emissions are controlled by good combustion controls. Mercury emissions are reduced by pre-combustion waste separation. Odor is controlled by drawing combustion air from the refuse tipping area. Units 1, 2 and 3 share a common stack and turbine containing one flue for each unit. Stack height = 195 feet, exit diameter = 7.5 feet, actual volumetric flow rate = 169,000 acfm. The particulate matter control device temperature requirement of 40 CFR 60, Subpart Cb will replace a maximum 300°F control equipment temperature requirement and an 1800°F final combustion chamber temperature requirement listed in the State Conditions of Certification (PA 86-22).

All three units are retrofitted with Selective Non-Catalytic Reduction (SNCR) NO_x controls to comply with NSPS - 40 CFR 60, Subpart Cb requirements. The new limits imposed in Subpart Cb are more stringent than PSD-FL-112 limits for SO₂, PM, VE, NO_x and Pb emissions from each unit. Pollutants regulated by Subpart Cb that were not regulated in PSD-FL-112 for all three units are Cd, HCl, Hg and dioxins/furans. Pollutants regulated in PSD-FL-112 that are not regulated by Subpart Cb are Be and Fl.

Compliance Assurance Monitoring (CAM) Applicability

The emission limits for pollutants for the three municipal waste combustors and auxiliary burners are equal to the NSPS, 40 CFR Subpart Cb limits, with the exception of beryllium, fluoride, and mercury. Because emissions limits for the following pollutants were taken directly from Subpart Cb, CAM is not applicable for the control devices for particulate matter, cadmium, lead, dioxins/furans, nitrogen oxides, sulfur dioxide, and hydrogen chloride.

As noted in the above paragraph, the PSD permit also contains beryllium, fluoride, and mercury emission limits. However, the Applicant provided justification that demonstrated that the uncontrolled potentials to emit the respective pollutants (PTE) are significantly less than ten (10) tons per year. Thus, CAM does

not apply to the control devices for these pollutants. The PSD permit also contains a carbon monoxide emission limit. But, since there is no control device at the facility for this pollutant, CAM does not apply.

{Permitting notes. These emissions units are regulated under NSPS - 40 CFR 60, Subpart Cb, Emissions Guidelines and Compliance Times for Large Municipal Waste Combustors That Are Constructed on or Before September 20, 1994, adopted and incorporated by reference, subject to provisions, in Rule 62-204.800(8)(b), F.A.C.; NSPS - 40 CFR 60, Subpart E, Standards of Performance for Incinerators, adopted and incorporated by reference in Rule 62-204.800(7), F.A.C.; Rule 62-212.400(5), F.A.C., Prevention of Significant Deterioration (PSD) (PSD-FL-112(B)); Rule 62-212.400(6), F.A.C., Best Available Control Technology (BACT); Rule 62-296.401(2), F.A.C., Incinerators; Rule 62-296.416, F.A.C., Waste-to-Energy Facilities; and, PA 86-22(B). Also, please note that conditions in 40 CFR 60, Subpart Cb, are contained in 40 CFR 60, Subpart Eb.}

The following specific conditions apply to the emissions unit(s) listed above:

General

B.1. The Standards of Performance for New Stationary Sources adopted by reference in Rule 62-204.800(7), F.A.C. and the Emission Guidelines for Existing Sources adopted by reference in Rule 62-204.800(8), F.A.C. shall be controlling over other standards in the air pollution rules of the Department, except that any emissions limiting standard contained in or determined pursuant to the air pollution rules of the Department which is more stringent than one contained in a Standard of Performance or an Emission Guideline, or which regulates emissions of pollutants or emissions units not regulated by an applicable Standard of Performance or Emission Guideline, shall apply.
[Rules 62-204.800(7)(c) and (8)(a)1., F.A.C.]

B.2. Definitions. For the purposes of Rules 62-204.800(7) and (8), F.A.C., the definitions contained in the various provisions of 40 CFR Part 60, adopted herein shall apply except that the term "Administrator" when used in 40 CFR Part 60, shall mean the Secretary or the Secretary's designee.
[40 CFR 60.2; and, Rules 62-204.800(7)(a) and (8)(a)2., F.A.C.]

B.3. Definitions – Subpart Cb. For purposes of Rule 62-204.800(8)(b), F.A.C., the definitions in 40 CFR 60.51b shall apply except for the term "municipal waste combustor plant" which shall have the same meaning as defined in 40 CFR 60.31b.
[Rule 62-204.800(8)(b)2., F.A.C.]

B.4. Circumvention. No owner or operator subject to the provisions of 40 CFR 60 shall build, erect, install, or use any article, machine, equipment or process, the use of which conceals an emission which would otherwise constitute a violation of an applicable standard. Such concealment includes, but is not limited to, the use of gaseous diluents to achieve compliance with an opacity standard or with a standard which is based on the concentration of a pollutant in the gases discharged to the atmosphere.
[40 CFR 60.12]

B.5. Notification and Reporting Requirements. For the purposes of this part, if an explicit postmark deadline is not specified in an applicable requirement for the submittal of a notification, application, report, or other written communication to the Administrator, the owner or operator shall postmark the submittal on or before the number of days specified in the applicable requirement. For example, if a notification must be submitted 15 days before a particular event is scheduled to take place, the notification shall be postmarked on or before 15 days preceding the event; likewise, if a notification must be submitted 15 days after a particular event takes place, the notification shall be delivered or postmarked

on or before 15 days following the end of the event. The use of reliable non-Government mail carriers that provide indications of verifiable delivery of information required to be submitted to the Administrator, similar to the postmark provided by the U.S. Postal Service, or alternative means of delivery, including the use of electronic media, agreed to by the permitting authority, is acceptable.

[40 CFR 60.19(b)]

B.6. Each incinerator boiler shall have a metal name plate affixed in a conspicuous place on the shell showing manufacturer, model number, type waste, rated capacity and certification number.

[PSD-FL-112]

B.7. Air Pollution Control Equipment. The permittee shall have installed, shall continuously operate, and shall maintain the following air pollution controls to minimize emissions. Controls listed shall be fully operational upon startup of the equipment.

a. Each boiler is equipped with a particulate emission control device for the control of particulates.

b. Each boiler is equipped with an acid gas control device designed to remove at least 90% of the acid gases.

c. Each boiler shall be equipped with a selective non-catalytic reduction system to control nitrogen oxides emissions.

d. Mercury is controlled by source separation techniques pursuant to Rule 62-296.416, F.A.C.

[PSD-FL-112(B)]

B.8. [Reserved.]

B.9. [Reserved.]

B.10. [Reserved.]

B.11. These units are subject to all applicable requirements of 40 CFR 60 Subpart Cb, Emissions Control Guidelines and Compliance Schedules for Municipal Solid Waste Combustors; Subpart E, NSPS for Incinerators; and, Rule 62-296.416 F.A.C., Waste-to-Energy Facilities, except that where requirements in this permit are more restrictive, the requirements in this permit shall apply.

[PSD-FL-112(B)]

Essential Potential to Emit (PTE) Parameters

B.12. Capacity.

(a) Each municipal waste combustor (MWC) unit shall have a maximum capacity of 186,000 pounds of steam produced per hour based on a 4-hour block averaged measurement. The maximum individual MWC throughput shall not exceed 807 tons MSW per day (2,420 tons per day entire facility) and 302.5 MMBtu/hr (108% rated capacity), as determined monthly (see specific condition B.110.).

(b) The procedures specified in paragraphs (1) and (2) shall be used for calculating municipal waste combustor unit capacity as defined under 40 CFR 60.51b.

(1) For municipal waste combustor units capable of combusting municipal solid waste continuously for a 24-hour period, municipal waste combustor unit capacity shall be calculated based on 24 hours of operation at the maximum charging rate. The maximum charging rate shall be determined as specified in paragraphs (i) and (ii) as applicable.

(i) For combustors that are designed based on heat capacity, the maximum charging rate shall be calculated based on the maximum design heat input capacity of the unit and a heating value of 12,800 kilojoules per kilogram for combustors firing refuse-derived fuel and a heating value of

10,500 kilojoules per kilogram for combustors firing municipal solid waste that is not refuse-derived fuel.

(ii) For combustors that are not designed based on heat capacity, the maximum charging rate shall be the maximum design charging rate.

(2) For batch feed municipal waste combustor units, municipal waste combustor unit capacity shall be calculated as the maximum design amount of municipal solid waste that can be charged per batch multiplied by the maximum number of batches that could be processed in a 24-hour period. The maximum number of batches that could be processed in a 24-hour period is calculated as 24 hours divided by the design number of hours required to process one batch of municipal solid waste, and may include fractional batches (e.g., if one batch requires 16 hours, then 24/16, or 1.5 batches, could be combusted in a 24-hour period). For batch combustors that are designed based on heat capacity, the design heating value of 12,800 kilojoules per kilogram for combustors firing refuse-derived fuel and a heating value of 10,500 kilojoules per kilogram for combustors firing municipal solid waste that is not refuse-derived fuel shall be used in calculating the municipal waste combustor unit capacity.

[40 CFR 60.31b and 40 CFR 60.58b(j); Rules 62-4.160(2) and 62-210.200(PTE), F.A.C.; and, PSD-FL-112(B)]

{Permitting note: Nothing in the following two conditions shall be construed to imply that maximum capacity, as defined in specific condition B.12., can be exceeded.}

B.13. Emissions Unit Operating Rate Limitation After Testing. See specific condition B.70.

[Rule 62-297.310(2), F.A.C.]

B.14. Unit Load. Unit load means the steam load of the municipal waste combustor (MWC) measured as specified in 40 CFR 60.58b(i)(6). Each MWC unit shall not operate at a load level greater than 110 percent of the unit's "maximum demonstrated unit load." The maximum demonstrated unit load is the highest 4-hour arithmetic averaged MWC unit load achieved during four consecutive hours during the most recent dioxin/furan performance stack test in which compliance with the dioxin/furan emission limit (see specific condition B.35.) was achieved. Higher loads are allowed for testing purposes as specified at 40 CFR 60.53b(b).

[40 CFR 60.34b(b) and 40 CFR 60.51b; and, PSD-FL-112(B)]

B.15. Maximum Demonstrated Particulate Matter Control Device Temperature. Maximum demonstrated particulate matter control device temperature means the highest 4-hour arithmetic average flue gas temperature measured at the particulate matter control device inlet during four consecutive hours during the most recent dioxin/furan performance test demonstrating compliance with the applicable limit for municipal waste combustor organics specified in specific condition B.35.

[40 CFR 60.34b(b) and 40 CFR 60.51b]

B.16. Methods of Operation - Fuels.

a. **Municipal Solid Waste Combustors.**

(1) **Municipal Solid Waste.** The primary fuel for this facility is municipal solid waste (MSW), including the items and materials that fit within the definition of MSW contained in either 40 CFR 60.51b or Section 403.706(5), F.S.

(2) **Unauthorized Fuel.** Subject to the limitations contained in this permit, the authorized fuels for the facility also include the other solid wastes that are not MSW which are described in (4), (5) and (6), below. However, the facility

(a) **shall not burn:**

(i) those materials that are prohibited by state or federal law;

- (ii) those materials that are prohibited by this permit;
 - (iii) those materials that are not authorized by this permit;
 - (iv) lead acid batteries;
 - (v) hazardous waste;
 - (vi) nuclear waste;
 - (vii) radioactive waste;
 - (viii) sewage sludge;
 - (ix) explosives;
 - (x) asbestos containing materials;
 - (xi) beryllium-containing waste, as defined in 40 CFR 61, Subpart C.
- (b) and shall not knowingly burn:
- (i) untreated biomedical waste from biomedical waste generators regulated pursuant to Chapter 64E-16, F.A.C., and from other similar generators (or sources);
 - (ii) segregated loads of biological waste.
- (3) The fuel may be received either as a mixture or as a single-item stream (segregated load) of discarded materials. If the facility intends to use an authorized fuel that is segregated non-MSW material, the fuel shall be either:
- (a) well mixed with MSW in the refuse pit; or
 - (b) alternately charged with MSW in the hopper.

The facility owner/operator shall prepare and maintain records concerning the description and quantities of all segregated loads of non-MSW material which are received and used as fuel at the facility, and subject to a percentage weight limitation, below [(5) and (6)]. For the purposes of this permit, a segregated load is defined to mean a container or truck that is almost completely or exclusively filled with a single item or homogeneous composition of waste material, as determined by visual inspection.

(4) Other Solid Waste. Subject to the conditions and limitations contained in this permit, the following other solid waste may be used as fuel at the facility:

- (a) Confidential, proprietary or special documents (including but not limited to business records, lottery tickets, event tickets, coupons, credit cards, magnetic tape and microfilm);
- (b) Contraband which is being destroyed at the request of appropriately authorized local, state or federal governmental agencies, provided that such material is not an explosive, a propellant, a hazardous waste, or otherwise prohibited at the facility. For the purposes of this section, contraband includes but is not limited to drugs, narcotics, fruits, vegetables, plants, counterfeit money, and counterfeit consumer goods;
- (c) Wood pallets, clean wood and land clearing debris;
- (d) Packaging materials and containers;
- (e) Clothing, natural and synthetic fibers, fabric remnants, and similar debris, including but not limited to aprons and gloves; and
- (f) Rugs, carpets, and floor coverings.

(5) Waste Tires. Subject to the conditions and limitations contained in this permit, waste tires may be used as fuel at the facility. The total quantity of waste tires received as segregated loads and burned at the facility shall not exceed 3%, by weight, of the facility's total fuel. Compliance with this limitation shall be determined by using a rolling 30 day average in accordance with specific condition B.111., below.

(6) Other Solid Waste/Segregated Loads. Subject to the conditions and limitations contained in this permit, the following other solid waste materials may be used as fuel at the facility (i.e. the following are authorized fuels that are non-MSW material). The total quantity of the following non-MSW material received as segregated loads and burned at the facility shall not exceed 5%, by weight, of the facility's

total fuel. Compliance with this limitation shall be determined by using a rolling 30 day average in accordance with specific condition B.111., below.

- (a) Construction and demolition debris.
 - (b) Oil spill debris from aquatic, coastal, estuarine or river environments. Such items or materials include but are not limited to rags, wipes, and absorbents.
 - (c) Items suitable for human, plant or domesticated animal use, consumption or application where the item's shelf-life has expired or the generator wishes to remove the items from the market. Such items or materials include but are not limited to off-specification or expired consumer products, pharmaceuticals, medications, health and personal care products, cosmetics, foodstuffs, nutritional supplements, returned goods, and controlled substances.
 - (d) Consumer-packaged products intended for human or domesticated animal use or application but not consumption. Such items or materials include but are not limited to carpet cleaners, household or bathroom cleaners, polishes, waxes and detergents.
 - (e) Waste materials that:
 - (i) are generated in the manufacture of items in categories (c) or (d), above and are functionally or commercially useless (expired, rejected or spent); or
 - (ii) are not yet formed or packaged for commercial distribution. Such items or materials must be substantially similar to other items or materials routinely found in MSW.
 - (f) Waste materials that contain oil from:
 - (i) the routine cleanup of industrial or commercial establishments and machinery; or
 - (ii) spills of virgin or used petroleum products. Such items or materials include but are not limited to rags, wipes, and absorbents.
 - (g) Used oil and used oil filters. Used oil containing a PCB concentration equal or greater than 50 ppm shall not be burned, pursuant to the limitations of 40 CFR 761.20(e).
 - (h) Waste materials generated by manufacturing, industrial or agricultural activities, provided that these items or materials are substantially similar to items or materials that are found routinely in MSW, subject to prior approval of the Department.
- b. Auxiliary Burners. Only distillate fuel oil or natural gas shall be used in the startup burners. Natural gas may be used as fuel during warm-up, startup, shutdown, and malfunction periods, and at other times when necessary and consistent with good combustion practices. The distillate fuel oil and natural gas shall not be used more than required during boiler startup or shutdown. The annual capacity factor for use of natural gas and oil shall be less than 10%. The annual capacity factor for natural gas/distillate fuel oil is the ratio between the heat input to the unit from natural gas/distillate fuel oil during a calendar year and the potential heat input to the unit had it been operated for 8,760 hours during a calendar year at the maximum steady state design heat input capacity.
- c. Other fuels or wastes shall not be burned in the MSW combustors without prior specific written approval of the Secretary of the Department of Environmental Protection.
[Rules 62-4.160(2), 62-210.200, and 62-213.440(1), F.A.C.; PSD-FL-112(B); and, PA 86-22]

B.17. To ensure that the facility's fuel does not adversely affect the facility's combustion process or emissions, the facility operator shall:

- (1) comply with good combustion operating practices in accordance with 40 CFR 60.53b;
- (2) install, operate and maintain continuous emissions monitors (CEMS) for oxygen, carbon monoxide, sulfur dioxide, oxides of nitrogen and particulate control device inlet temperature in accordance with 40 CFR 60.58b; and
- (3) record and maintain the CEMS data in accordance with 40 CFR 60.59b. These steps shall be used to ensure and verify continuous compliance with the emissions limitations in this permit.

[PSD-FL-112(B)]

B.18. Hours of Operation. MWC units 1, 2 and 3 are allowed to operate continuously, i.e., 8,760 hours/year, each.
[Rule 62-210.200(PTE), F.A.C.]

Operating Practices and Requirements

B.19. No owner or operator of an affected facility shall cause such facility to operate at a load level greater than 110 percent of the maximum demonstrated municipal waste combustor unit load as defined in specific condition B.14., except as specified below. The averaging time is specified in specific condition B.21.

(1) During the annual dioxin/furan performance test and the two weeks preceding the annual dioxin/furan performance test, no municipal waste combustor unit load limit is applicable.

(2) The municipal waste combustor unit load limit may be waived in accordance with permission granted by the Administrator or delegated State regulatory authority for the purpose of evaluating system performance, testing new technology or control technologies, diagnostic testing, or related activities for the purpose of improving facility performance or advancing the state-of-the-art for controlling facility emissions.

[40 CFR 60.34b(b) and 40 CFR 60.53b(b)]

B.20. No owner or operator of an affected facility shall cause such facility to operate at a temperature, measured at the particulate matter control device inlet, exceeding 17°C above the maximum demonstrated particulate matter control device temperature as defined in specific condition B.15., except as specified below. The averaging time is specified in specific condition B.21. These requirements apply to each particulate matter control device utilized at the affected facility.

(1) During the annual dioxin/furan performance test and the two weeks preceding the annual dioxin/furan performance test, no particulate matter control device temperature limitations are applicable.

(2) The particulate matter control device temperature limits may be waived in accordance with permission granted by the Administrator or delegated State regulatory authority for the purpose of evaluating system performance, testing new technology or control technologies, diagnostic testing, or related activities for the purpose of improving facility performance or advancing the state-of-the-art for controlling facility emissions.

[40 CFR 60.34b(b) and 40 CFR 60.53b(c)]

B.21. Operating Requirements. The procedures specified in paragraphs (1) through (12) shall be used for determining compliance with the operating requirements under 40 CFR 60.53b.

(1) Compliance with the carbon monoxide emission limits in 40 CFR 60.53b(a) shall be determined using a 4-hour block arithmetic average for all types of affected facilities except mass burn rotary waterwall municipal waste combustors and refuse-derived fuel stokers.

(2) For affected mass burn rotary waterwall municipal waste combustors and refuse-derived fuel stokers, compliance with the carbon monoxide emission limits in 40 CFR 60.53b(a) shall be determined using a 24-hour daily arithmetic average.

(3) The owner or operator of an affected facility shall install, calibrate, maintain, and operate a continuous emission monitoring system for measuring carbon monoxide at the combustor outlet and record the output of the system and shall follow the procedures and methods specified in paragraphs(i) through(iii).

(i) The continuous emission monitoring system shall be operated according to Performance Specification 4A in Appendix B of 40 CFR 60.

(ii) During each relative accuracy test run of the continuous emission monitoring system required by Performance Specification 4A in Appendix B of 40 CFR 60, carbon monoxide and oxygen (or carbon

dioxide) data shall be collected concurrently (or within a 30- to 60-minute period) by both the continuous emission monitors and the test methods specified in paragraphs (A) and (B).

(A) For carbon monoxide, EPA Reference Method 10, 10A, or 10B shall be used.

(B) For oxygen (or carbon dioxide), EPA Reference Method 3, 3A or 3B, as applicable shall be used.

(iii) The span value of the continuous emission monitoring system shall be 125 percent of the maximum estimated hourly potential carbon monoxide emissions of the municipal waste combustor unit.

(4) The 4-hour block and 24-hour daily arithmetic averages specified in paragraphs (1) and (2) shall be calculated from 1-hour arithmetic averages expressed in parts per million by volume corrected to 7 percent oxygen (dry basis). The 1-hour arithmetic averages shall be calculated using the data points generated by the continuous emission monitoring system. At least two data points shall be used to calculate each 1-hour arithmetic average.

(5) The owner or operator of an affected facility may request that compliance with the carbon monoxide emission limit be determined using carbon dioxide measurements corrected to an equivalent of 7 percent oxygen. The relationship between oxygen and carbon dioxide levels for the affected facility shall be established as specified in 40 CFR 60.58b(b)(6).

(6) The procedures specified in paragraphs (i) through (v) shall be used to determine compliance with load level requirements under 40 CFR 60.53b(b).

(i) The owner or operator of an affected facility with steam generation capability shall install, calibrate, maintain, and operate a steam flow meter or a feedwater flow meter; measure steam (or feedwater) flow in kilograms per hour (or pounds per hour) on a continuous basis; and record the output of the monitor. Steam (or feedwater) flow shall be calculated in 4-hour block arithmetic averages.

(ii) The method included in the "American Society of Mechanical Engineers Power Test Codes: Test Code for Steam Generating Units, Power Test Code 4.1-1964 (R1991)" section 4 (incorporated by reference, see 40 CFR 60.17) shall be used for calculating the steam (or feedwater) flow required under paragraph (6)(i). The recommendations in "American Society of Mechanical Engineers Interim Supplement 19.5 on Instruments and Apparatus: Application, Part II of Fluid Meters, 6th edition (1971)," chapter 4 (incorporated by reference-see 40 CFR 60.17) shall be followed for design, construction, installation, calibration, and use of nozzles and orifices except as specified in (iii).

(iii) Measurement devices such as flow nozzles and orifices are not required to be recalibrated after they are installed.

(iv) All signal conversion elements associated with steam (or feedwater flow) measurements must be calibrated according to the manufacturer's instructions before each dioxin/furan performance test, and at least once per year.

(7) To determine compliance with the maximum particulate matter control device temperature requirements under 40 CFR 60.53b(c), the owner or operator of an affected facility shall install, calibrate, maintain, and operate a device for measuring on a continuous basis the temperature of the flue gas stream at the inlet to each particulate matter control device utilized by the affected facility. Temperature shall be calculated in 4-hour block arithmetic averages.

(8) The maximum demonstrated municipal waste combustor unit load shall be determined during the initial performance test for dioxins/furans and each subsequent performance test during which compliance with the dioxin/furan emission limit specified in 40 CFR 60.52b(c) is achieved. The maximum demonstrated municipal waste combustor unit load shall be the highest 4-hour arithmetic average load achieved during four consecutive hours during the most recent test during which compliance with the dioxin/furan emission limit was achieved.

(9) For each particulate matter control device employed at the affected facility, the maximum demonstrated particulate matter control device temperature shall be determined during the initial

performance test for dioxins/furans and each subsequent performance test during which compliance with the dioxin/furan emission limit specified in 40 CFR 60.52b(c) is achieved. The maximum demonstrated particulate matter control device temperature shall be the highest 4-hour arithmetic average temperature achieved at the particulate matter control device inlet during four consecutive hours during the most recent test during which compliance with the dioxin/furan limit was achieved.

(10) At a minimum, valid continuous emission monitoring system hourly averages shall be obtained as specified in paragraphs (i) and (ii) for 75 percent of the operating hours per day for 90 percent of the operating days per calendar quarter that the affected facility is combusting municipal solid waste.

(i) At least two data points per hour shall be used to calculate each 1-hour arithmetic average.

(ii) At a minimum, each carbon monoxide 1-hour arithmetic average shall be corrected to 7 percent oxygen on an hourly basis using the 1-hour arithmetic average of the oxygen (or carbon dioxide) continuous emission monitoring system data.

(11) All valid continuous emission monitoring system data must be used in calculating the parameters specified under 40 CFR 60.58b(i) even if the minimum data requirements of paragraph (10) are not met. When carbon monoxide continuous emission data are not obtained because of continuous emission monitoring system breakdowns, repairs, calibration checks, and zero and span adjustments, emissions data shall be obtained using other monitoring systems as approved by the Administrator or EPA Reference Method 10 to provide, as necessary, the minimum valid emission data.

(12) Quarterly accuracy determinations and daily calibration drift tests for the carbon monoxide continuous emission monitoring system shall be performed in accordance with procedure 1 in Appendix F of 40 CFR 60.

{Permitting Note: CO and O₂ are monitored downstream of the combustor outlet at the fabric filter exit, as approved by EPA.}

[40 CFR 60.38b and 40 CFR 60.58b(i)]

Operator Training and Certification

B.22. Standards for municipal waste combustor operator training and certification.

(a) No later than the date 6 months after the date of startup of an affected facility or 12 months after State plan approval [40 CFR 60.39b(c)(4)(ii)], whichever is later, each chief facility operator and shift supervisor shall obtain and maintain a current provisional operator certification from either the American Society of Mechanical Engineers [QRO-1-1994 (incorporated by reference - see 40 CFR 60.17 of Subpart A)] or a State certification program.

(b) No later than the date 6 months after the date of startup of an affected facility or 12 months after State plan approval [40 CFR 60.39b(c)(4)(ii)], whichever is later, each chief facility operator and shift supervisor shall have completed full certification or shall have scheduled a full certification exam with either the American Society of Mechanical Engineers [QRO-1-1994 (incorporated by reference - see 40 CFR 60.17 of Subpart A)] or a State certification program.

(c) No owner or operator of an affected facility shall allow the facility to be operated at any time unless one of the following persons is on duty and at the affected facility: A fully certified chief facility operator, a provisionally certified chief facility operator who is scheduled to take the full certification exam according to the schedule specified in paragraph (b), a fully certified shift supervisor, a provisionally certified shift supervisor who is scheduled to take the full certification exam according to the schedule specified in paragraph (b).

(1) The requirement specified in paragraph (c) shall take effect 6 month after the date of startup of the affected facility or 12 months after State plan approval [40 CFR 60.39b(c)(4)(ii)], whichever is later.

(2) If one of the persons listed in paragraph (c) must leave the affected facility during their operating shift, a provisionally certified control room operator who is onsite at the affected facility may fulfill the requirement in paragraph (c).

(d) All chief facility operators, shift supervisors, and control room operators at affected facilities must complete the EPA or State municipal waste combustor operator training course no later than the date 6 months after the date of startup of the affected facility, or by 12 months after State plan approval [40 CFR 60.39b(c)(4)(iii)], whichever is later.

(e) The owner or operator of an affected facility shall develop and update on a yearly basis a site-specific operating manual that shall, at a minimum, address the elements of municipal waste combustor unit operation specified in paragraph (e)(1) through (e)(11).

- (1) A summary of the applicable standards;
- (2) A description of basic combustion theory applicable to a municipal waste combustor unit;
- (3) Procedures for receiving, handling, and feeding municipal solid waste;
- (4) Municipal waste combustor unit startup, shutdown, and malfunction procedures;
- (5) Procedures for maintaining proper combustion air supply levels;
- (6) Procedures for operating the municipal waste combustor unit within the standards established;
- (7) Procedures for responding to periodic upset or off-specification conditions;
- (8) Procedures for minimizing particulate matter carryover;
- (9) Procedures for handling ash;
- (10) Procedures for monitoring municipal waste combustor unit emissions; and
- (11) Reporting and recordkeeping procedures.

(f) The owner or operator of an affected facility shall establish a training program to review the operating manual according to the schedule specified in paragraphs (f)(1) and (f)(2) with each person who has responsibilities affecting the operation of an affected facility including, but not limited to, chief facility operators, shift supervisors, control room operators, ash handlers, maintenance personnel, and crane/load handlers.

(1) Each person specified in paragraph (f) shall undergo initial training no later than the date specified in paragraph (f)(1)(i), (f)(1)(ii), or (f)(1)(iii), whichever is later.

(i) The date 6 months after the date of startup of the affected facility;

(ii) The date prior to the day the person assumes responsibilities affecting municipal waste combustor unit operation; or

(iii) 12 months after State plan approval [40 CFR 60.39b(c)(4)(iii)].

(2) Annually, following the initial review required by paragraph (f)(1).

(g) The operating manual required by paragraph (e) shall be kept in a readily accessible location for all persons required to undergo training under paragraph (f). The operating manual and records of training shall be available for inspection by the EPA or its delegated enforcement agency upon request.

[40 CFR 60.35b, 40 CFR 60.39b(c)(4)(ii) & (iii), and 40 CFR 60.54b]

B.23. The requirement specified in 40 CFR 60.54b(d) does not apply to chief operators, shift supervisors, and control room operators who have obtained full certification from the American Society of Mechanical Engineers on or before the date of State plan approval.

[40 CFR 60.39b(c)(4)(iii)(A)]

B.24. The owner or operator of a designated facility may request that the EPA Administrator waive the requirement specified in 40 CFR 60.54b(d) for chief operators, shift supervisors, and control room operators who have obtained provisional certification from the American Society of Mechanical Engineers on or before the date of State plan approval.

[40 CFR 60.39b(c)(4)(iii)(B)]

B.25. The initial training requirements specified in 40 CFR 60.54b(f)(1) shall be completed no later than the date specified in (1), (2) or (3), whichever is later.

- (1) The date six (6) months after the date of startup of the affected facility;
- (2) Twelve (12) months after State plan approval; or
- (3) The date prior to the day when the person assumes responsibilities affecting municipal waste combustor unit operation.

[40 CFR 60.39b(c)(4)(iii)(C)]

Emission Limitations and Standards

{Permitting note: Table 1-1, Summary of Air Pollutant Standards and Terms, summarizes information for convenience purposes only. This table does not supersede any of the terms or conditions of this permit. Also, Subpart Cb does not impose limits for Be and total fluorides, which are limited by PSD-FL-112(B)}

{Permitting note: The averaging times for Specific Conditions B.26. through B.40. are based on the run times of the specified test method.}

Particulate Matter

B.26. The emission limit for particulate matter contained in the gases discharged to the atmosphere is 27 milligrams per dry standard cubic meter, corrected to 7 percent oxygen.

[40 CFR 60.33b(a)(1)(i) and PSD-FL-112(B)]

Visible Emissions

B.27. The emission limit for opacity exhibited by the gases discharged to the atmosphere is 10 percent (6-minute average).

[40 CFR 60.33b(a)(1)(iii) and PSD-FL-112(B)]

Cadmium

B.28. The emission limit for cadmium contained in the gases discharged to the atmosphere is 0.040 milligrams per dry standard cubic meter, corrected to 7 percent oxygen.

[40 CFR 60.33b(a)(2)(i) and PSD-FL-112(B)]

Mercury

B.29. The emission limit for mercury contained in the gases discharged to the atmosphere is 0.070 milligrams per dry standard cubic meter or 15 percent of the potential mercury emission concentration (85-percent reduction by weight), corrected to 7 percent oxygen, whichever is less stringent.

[40 CFR 60.33b(a)(3) and Rule 62-296.416(3)(b)1.b., F.A.C.; and, PSD-FL-112(B)]

B.30. Emissions Standards for Facilities Using Waste Separation. The Department recognizes that reduction of mercury emissions from waste-to-energy facilities may be achieved by implementation of mercury waste separation programs. Such programs would require removal of objects containing mercury from the waste stream before the waste is used as a fuel.

1. Facilities with sulfur dioxide and hydrogen chloride control equipment in place or under construction as of July 1, 1993, and which choose to control mercury emissions exclusively through the use of a waste separation program, shall submit a program plan to the Department by March 1, 1994, and shall comply with the following emissions limiting schedule.

- a. After July 1, 1995, mercury emissions shall not exceed 140 micrograms per dry standard cubic meter of flue gas, corrected to 7 percent O₂.
 - b. After July 1, 1997, mercury emissions shall not exceed 70 micrograms per dry standard cubic meter of flue gas, corrected to 7 percent O₂.
2. Beginning no later than July 1, 1994, facilities subject to Rule 62-296.416(3)(b)1., F.A.C., shall perform semiannual individual emissions unit mercury emissions tests. Facilities shall stagger the semiannual testing of individual emissions units such that at least one test is performed quarterly. All tests conducted after July 1, 1995, shall be used to demonstrate compliance with the mercury emissions limiting standards of Rule 62-296.416(3)(b)1., F.A.C.
[Rule 62-296.416(3)(b), F.A.C.]

Lead

B.31. The emission limit for lead contained in the gases discharged to the atmosphere is 0.44 milligrams per dry standard cubic meter, corrected to 7 percent oxygen.
[40 CFR 60.33b(a)(4) and PSD-FL-112(B)]

Sulfur Dioxide

B.32. The emission limit for sulfur dioxide contained in the gases discharged to the atmosphere is 29 parts per million by volume or 25 percent of the potential sulfur dioxide emission concentration (75-percent reduction by weight or volume), corrected to 7 percent oxygen (dry basis), whichever is less stringent. Compliance with this emission limit is based on a 24-hour daily geometric mean.
[40 CFR 60.33b(b)(3)(i) and PSD-FL-112(B)]

B.33. Not federally enforceable. Sulfur Content. The sulfur content of the distillate fuel oil or natural gas for the auxiliary burner shall not exceed 0.3%, by weight.
[PA-86-22]

Hydrogen Chloride

B.34. The emission limit for hydrogen chloride contained in the gases discharged to the atmosphere is 29 parts per million by volume or 5 percent of the potential hydrogen chloride emission concentration (95-percent reduction by weight or volume), corrected to 7 percent oxygen (dry basis), whichever is less stringent.
[40 CFR 60.33b(b)(3)(ii) and PSD-FL-112(B)]

Dioxins/Furans

B.35. The emission limit for dioxins/furans contained in the gases discharged to the atmosphere that do not employ an electrostatic precipitator-based emission control system is 30 nanograms per dry standard cubic meter (total mass of tetra- through octa chlorinated dibenzo-p-dioxins and dibenzofurans), corrected to 7 percent oxygen.
[40 CFR 60.33b(c)(1)(ii) and PSD-FL-112(B)]

Nitrogen Oxides

B.36. The emission limit for nitrogen oxides contained in the gases discharged to the atmosphere is 205 parts per million by volume, corrected to 7 percent oxygen, dry basis. The permittee may request

authorization from the Department to conduct nitrogen oxides emissions averaging pursuant to 40 CFR 60.33b.

[40 CFR 60.33b(d) and PSD-FL-112(B)]

Carbon Monoxide

B.37. The emission limit for carbon monoxide contained in the gases discharged to the atmosphere is 100 parts per million by volume, measured at the combustor outlet in conjunction with a measurement of oxygen concentration, corrected to 7 percent oxygen, dry basis. Calculated as an arithmetic average. Averaging time is a 4-hour block average.

[40 CFR 60.34b(a) and PSD-FL-112(B)]

Fugitive Ash Emissions

B.38. (a) On and after the date on which the initial performance test is completed or is required to be completed under 40 CFR 60.8 of Subpart A (see specific condition B.50.), no owner or operator of an affected facility shall cause to be discharged to the atmosphere visible emissions of combustion ash from an ash conveying system (including conveyor transfer points) in excess of 5 percent of the observation period (i.e., 9 minutes per 3-hour period), as determined by EPA Reference Method 22 observations as specified in 40 CFR 60.58b(k), except as provided in paragraphs (b) and (c). See specific condition B.64.

(b) The emission limit specified in paragraph (a) does not cover visible emissions discharged inside buildings or enclosures of ash conveying systems; however, the emission limit specified in paragraph (a) does cover visible emissions discharged to the atmosphere from buildings or enclosures of ash conveying systems (including conveyor transfer points) and the wet scrubber vent. (This scrubber has not been installed, but may be installed in the future should facility management deem it necessary for ash building indoor air quality control.)

(c) The provisions of paragraph (a) do not apply during maintenance and repair of ash conveying systems.

[40 CFR 60.36b and 40 CFR 60.55b; and PSD-FL-112(B) & PSD-FL-112(C)]

Beryllium

B.39. Stack emissions of beryllium from each unit shall not exceed 0.001 mg/dscm, corrected to 7% O₂.

[PSD-FL-112(B)]

Total Fluorides

B.40. Stack emissions of total fluorides from each unit shall not exceed 0.0040 lb/MMBtu.

[PSD-FL-112(B)]

B.41. [Reserved.]

{Permitting Note: Listed below are equivalent emissions for the MWC units:

Pollutant	lbs/MMBtu/unit	lbs/hr/unit	tons/year/unit
Particulate Matter (PM/PM ₁₀)	0.024	7.35	32.24
Cadmium (Cd)	3.6 x 10 ⁻⁵	0.011	0.048
Mercury (Hg)	6.3 x 10 ⁻⁵	0.019	0.08
Lead (Pb)	4.4 x 10 ⁻⁴	0.133	0.58

Sulfur Dioxide (SO ₂)	0.11	32.8	143.5
Hydrogen Chloride (HCl)	0.04	11.7	51.3
Dioxins/Furans	2.7 x 10 ⁻⁸	8.2 x 10 ⁻⁶	3.6 x 10 ⁻⁵
Nitrogen Oxides (NO _x)	0.35	106.5	466.4
Carbon Monoxide (CO)	0.105	31.8	139.1
Beryllium (Be)	9.3 x 10 ⁻⁷	0.0003	0.0012
Fluorides (F)	0.0040	1.21	5.29

These values are given in PSD-FL-112(B) and are determined using the F factor of 14,389 dscf @ 7% O₂ /MMBtu and a maximum heat input of 302.5 MMBtu/hr.}

Excess Emissions

{Permitting Note: The Excess Emissions Rule at Rule 62-210.700, F.A.C., cannot vary any requirement of an NSPS or NESHAP provision.}

B.42. The opacity standards set forth in 40 CFR 60 shall apply at all times except during periods of startup, shutdown, malfunction, and as otherwise provided in the applicable standard.
 [40 CFR 60.11(c)]

B.43. At all times, including periods of startup, shutdown, and malfunction, owners and operators shall, to the extent practicable, maintain and operate any affected facility including associated air pollution control equipment in a manner consistent with good air pollution control practice for minimizing emissions. Determination of whether acceptable operating and maintenance procedures are being used will be based on information available to the Administrator which may include, but is not limited to, monitoring results, opacity observations, review of operating and maintenance procedures, and inspection of the source.
 [40 CFR 60.11(d)]

B.44.a. Startup, Shutdown and Malfunction. Except as provided by 40 CFR 60.56b, the standards under 40 CFR 60, Subpart Cb, as incorporated in Rule 62-204.800(8)(b), F.A.C., apply at all times except during periods of startup, shutdown, or malfunction. Duration of startup or shutdown periods are limited to 3 hours per occurrence, except as provided in 40 CFR 60.58b(a)(1)iii.

(i) The startup period commences when the affected facility begins the continuous burning of municipal solid waste and does not include any warm-up period when the affected facility is combusting fossil fuel or other nonmunicipal solid waste fuel, and no municipal solid waste is being fed to the combustor.

(ii) Continuous burning is the continuous, semicontinuous, or batch feeding of municipal solid waste for purposes of waste disposal, energy production, or providing heat to the combustion system in preparation for waste disposal or energy production. The use of municipal solid waste solely to provide thermal protection of the grate or hearth during the startup period when municipal solid waste is not being fed to the grate is not considered to be continuous burning.
 [40 CFR 60.38b and 40 CFR 60.58b(a)]

B.44.b. For the purpose of compliance with the carbon monoxide emission limits in 40 CFR 60.53b(a), if a loss of boiler water level control (e.g., loss of combustion air fan, induced draft fan, combustion grate bar failure) is determined to be a malfunction, the duration of the malfunction period is limited to 15 hours per occurrence.
 [40 CFR 60.58b(a)(1)iii]

B.45. Excess emissions indicated by the CEM systems shall be considered violations of the applicable opacity limit or operating emission limits (in ppm) for the purposes of this permit provided the data

represents accurate emission levels and the CEMs do not exceed the calibration drift (as specified in the respective performance specification tests) on the day when initial and subsequent compliance is determined. The burden of proof to demonstrate that the data does not reflect accurate emission readings shall be the responsibility of the permittee.

[PSD-FL-112]

B.46. Excess emissions resulting from startup, shutdown, or malfunction shall be permitted provided that best operational practices to minimize emissions are adhered to and the duration of excess emissions shall be minimized but in no case exceed three hours in any 24 hour period.

[Rule 62-210.700(1), F.A.C.; and, authorized by Department on June 21, 2000]

B.47. Excess emissions which are caused entirely or in part by poor maintenance, poor operation, or any other equipment or process failure which may reasonably be prevented during start-up, shutdown, or malfunction shall be prohibited.

[Rule 62-210.700(4), F.A.C.; and, PSD-FL-112(B)]

Test Methods and Procedures

{Permitting note: Table 2-1, Summary of Compliance Requirements, summarizes information for convenience purposes only. This table does not supersede any of the terms or conditions of this permit.}

B.48. Within 60 days after achieving the maximum production rate at which the affected facility will be operated, but not later than 180 days after initial startup of such facility and at such other times as may be required by the Administrator under section 114 of the Act, the owner or operator of such facility shall conduct performance test(s) and furnish the Administrator a written report of the results of such performance test(s).

[40 CFR 60.8(a)]

B.49. Performance tests shall be conducted and data reduced in accordance with the test methods and procedures contained in each applicable subpart unless the Administrator (1) specifies or approves, in specific cases, the use of a reference method with minor changes in methodology, (2) approves the use of an equivalent method, (3) approves the use of an alternative method the results of which he has determined to be adequate for indicating whether a specific source is in compliance, (4) waives the requirement for performance tests because the owner or operator of a source has demonstrated by other means to the Administrator's satisfaction that the affected facility is in compliance with the standard, or (5) approves shorter sampling times and smaller sample volumes when necessitated by process variables or other factors. Nothing in this paragraph shall be construed to abrogate the Administrator's authority to require testing under section 114 of the Act.

[40 CFR 60.8(b)]

B.50. Performance tests shall be conducted under such conditions as the Administrator shall specify to the plant operator based on representative performance of the affected facility. The owner or operator shall make available to the Administrator such records as may be necessary to determine the conditions of the performance tests. Operations during periods of startup, shutdown, and malfunction shall not constitute representative conditions for the purpose of a performance test nor shall emissions in excess of the level of the applicable emission limit during periods of startup, shutdown, and malfunction be considered a violation of the applicable emission limit unless otherwise specified in the applicable standard.

[40 CFR 60.8(c)]

B.51. The owner or operator of an affected facility shall provide the Administrator at least 30 days prior notice of any performance test, except as specified under other subparts, to afford the Administrator the opportunity to have an observer present.

[40 CFR 60.8(d)]

B.52. The owner or operator of an affected facility shall provide, or cause to be provided, performance testing facilities as follows:

(1) Sampling ports adequate for test methods applicable to such facility. This includes (i) constructing the air pollution control system such that volumetric flow rates and pollutant emission rates can be accurately determined by applicable test methods and procedures and (ii) providing a stack or duct free of cyclonic flow during performance tests, as demonstrated by applicable test methods and procedures.

(2) Safe sampling platform(s).

(3) Safe access to sampling platform(s).

(4) Utilities for sampling and testing equipment.

{Permitting note: See specific condition B.73. and Appendix SS-1, Stack Sampling Facilities (version dated 10/7/96) for State of Florida Stack Sampling Requirements.}

[40 CFR 60.8(e)]

B.53. Unless otherwise specified in the applicable subpart, each performance test shall consist of three separate runs using the applicable test method. Each run shall be conducted for the time and under the conditions specified in the applicable standard. For the purpose of determining compliance with an applicable standard, the arithmetic means of results of the three runs shall apply. In the event that a sample is accidentally lost or conditions occur in which one of the three runs must be discontinued because of forced shutdown, failure of an irreplaceable portion of the sample train, extreme meteorological conditions, or other circumstances, beyond the owner or operator's control, compliance may, upon the Administrator's approval, be determined using the arithmetic mean of the results of the two other runs.

[40 CFR 60.8(f)]

Particulate Matter and Opacity

B.54. The procedures and test methods specified in paragraphs (1) through (11) shall be used to determine compliance with the emission limits for particulate matter and opacity.

(1) The EPA Reference Method 1 shall be used to select sampling site and number of traverse points.

(2) The EPA Reference Method 3, 3A or 3B, as applicable shall be used for gas analysis.

(3) The EPA Reference Method 5 shall be used for determining compliance with the particulate matter emission limit. The minimum sample volume shall be 1.7 cubic meters. The probe and filter holder heating systems in the sample train shall be set to provide a gas temperature no greater than 160 ± 14 °C. An oxygen or carbon dioxide measurement shall be obtained simultaneously with each Method 5 run.

(4) The owner or operator of an affected facility may request that compliance with the particulate matter emission limit be determined using carbon dioxide measurements corrected to an equivalent of 7 percent oxygen. The relationship between oxygen and carbon dioxide levels for the affected facility shall be established as specified in paragraph 40 CFR 60.58b(b)(6).

(5) As specified under 40 CFR 60.8, all performance tests shall consist of three test runs. The average of the particulate matter emission concentrations from the three test runs is used to determine compliance.

- (6) In accordance with paragraphs (7) and (11), EPA Reference Method 9 shall be used for determining compliance with the opacity limit except as provided under 40 CFR 60.11(e)
- (7) The owner or operator of an affected facility shall conduct an initial performance test for particulate matter emissions and opacity as required under 40 CFR 60.8.
- (8) The owner or operator of an affected facility shall install, calibrate, maintain and operate a continuous opacity monitoring system for measuring opacity and shall follow the methods and procedures specified in paragraphs (8)(i) through (8)(iv).
- (i) The output of the continuous opacity monitoring system shall be recorded on a 6-minute average basis.
 - (ii) The continuous opacity monitoring system shall be installed, evaluated and operated in accordance with 40 CFR 60.13.
 - (iii) The continuous opacity monitoring system shall conform to Performance Specification 1 in Appendix B of 40 CFR 60.
 - (iv) The initial performance evaluation shall be completed no later than 180 days after the date of the initial startup of the municipal waste combustor unit, as specified under 40 CFR 60.8.
- (9) Following the date that the initial performance test for particulate matter is completed or is required to be completed under 40 CFR 60.8 for an affected facility, the owner or operator shall conduct a performance test for particulate matter on an annual basis (no more than 12 calendar months following the previous performance test).
- (10) [reserved]
- (11) Following the date that the initial performance test for opacity is completed or is required to be completed under 40 CFR 60.8 for an affected facility, the owner or operator shall conduct a performance test for opacity on an annual basis (no more than 12 calendar months following the previous performance test) using the test method specified in paragraph (6).
[40 CFR 60.38b and 40 CFR 60.58b(c)]

Cadmium, Lead and Mercury

B.55. The procedures and test methods specified in paragraphs (1) and (2) shall be used to determine compliance with the emission limits for cadmium, lead, and mercury.

- (1) The procedures and test methods specified in paragraphs (1)(i) through (1)(ix) shall be used to determine compliance with the emission limits for cadmium and lead.
- (i) The EPA Reference Method 1 shall be used for determining the location and number of sampling points.
 - (ii) The EPA Reference Method 3, 3A or 3B, as applicable, shall be used for flue gas analysis.
 - (iii) The EPA Reference Method 29 shall be used for determining compliance with the cadmium and lead emission limits.
 - (iv) An oxygen or carbon dioxide measurement shall be obtained simultaneously with each Method 29 test run for cadmium and lead required under paragraph (1)(iii).
 - (v) The owner or operator of an affected facility may request that compliance with the cadmium or lead emission limit be determined using carbon dioxide measurements corrected to an equivalent of 7 percent oxygen. The relationship between oxygen and carbon dioxide levels for the affected facility shall be established as specified in paragraph 40 CFR 60.58b(b)(6).
 - (vi) All performance tests shall consist of a minimum of three test runs conducted under representative full load operating conditions. The average of the cadmium or lead emission concentrations from three test runs or more shall be used to determine compliance.
 - (vii) Following the date of the initial performance test or the date on which the initial performance test is required to be completed under 40 CFR 60.8, the owner or operator of an affected facility shall

conduct a performance test for compliance with the emission limits for cadmium and lead on an annual basis (no more than 12 calendar months following the previous performance test).

(viii)[reserved]

(ix) [reserved]

(2) The procedures and test methods specified in paragraphs (2)(i) through (2)(xi) shall be used to determine compliance with the mercury emission limit.

(i) The EPA Reference Method 1 shall be used for determining the location and number of sampling points.

(ii) The EPA Reference Method 3, 3A or 3B, as applicable, shall be used for flue gas analysis.

(iii) The EPA Reference Method 29 shall be used to determine the mercury emission concentration. The minimum sample volume when using Method 29 for mercury shall be 1.7 cubic meters.

(iv) An oxygen (or carbon dioxide) measurement shall be obtained simultaneously with each Method 29 test run for mercury required under paragraph (2)(iii).

(v) The percent reduction in the potential mercury emissions (%PHG) is computed using equation 1:

$$[\%PHG] = \left[\frac{E_i - E_o}{E_i} \right] \times 100 \quad (\text{equation 1})$$

where:

%PHG = percent reduction of the potential mercury emissions achieved.

E_i = potential mercury emission concentration measured at the control device inlet, corrected to 7 percent oxygen (dry basis).

E_o = controlled mercury emission concentration measured at the mercury control device outlet, corrected to 7 percent oxygen (dry basis).

(vi) All performance tests shall consist of a minimum of three test runs conducted under representative full load operating conditions. The average of the mercury emission concentrations or percent reductions from three test runs or more is used to determine compliance.

(vii) The owner or operator of an affected facility may request that compliance with the mercury emission limit be determined using carbon dioxide measurements corrected to an equivalent of 7 percent oxygen. The relationship between oxygen and carbon dioxide levels for the affected facility shall be established as specified in paragraph 40 CFR 60.58b(b)(6).

(viii) The owner or operator of an affected facility shall conduct an initial performance test for mercury emissions as required under 40 CFR 60.8.

(ix) Following the date that the initial performance test for mercury is completed or is required to be completed under 40 CFR 60.8, the owner or operator of an affected facility shall conduct a performance test for mercury emissions on an annual basis (no more than 12 calendar months from the previous performance test).

(x) [reserved]

[40 CFR 60.38b and 40 CFR 60.58b(d)]

B.56. Mercury Emissions Test Method and Procedures. All mercury emissions tests performed pursuant to the requirements of this rule shall comply with the following provisions.

1. The test method for mercury shall be EPA Method 29 adopted in Rule 62-297, F.A.C.

2. Test procedures shall meet all applicable requirements of Chapter 62-297, F.A.C.
[Rule 62-296.416(3)(d), F.A.C.]

B.57. Mercury emissions testing shall be conducted semiannually. Mercury stack tests shall be performed downstream of control devices or upstream and downstream of the control devices when determining compliance with the alternative removal requirement.
[PSD-FL-112(B)]

Sulfur Dioxide

B.58. The procedures and test methods specified in paragraphs (1) through (14) shall be used for determining compliance with the sulfur dioxide emission.

(1) The EPA Reference Method 19, section 4.3, shall be used to calculate the daily geometric average sulfur dioxide emission concentration.

(2) The EPA Reference Method 19, section 5.4, shall be used to determine the daily geometric average percent reduction in the potential sulfur dioxide emission concentration.

(3) The owner or operator of an affected facility may request that compliance with the sulfur dioxide emission limit be determined using carbon dioxide measurements corrected to an equivalent of 7 percent oxygen. The relationship between oxygen and carbon dioxide levels for the affected facility shall be established as specified in 40 CFR 60.58b(b)(6).

(4) The owner or operator of an affected facility shall conduct an initial performance test for sulfur dioxide emissions as required under 40 CFR 60.8. Compliance with the sulfur dioxide emission limit (concentration or percent reduction) shall be determined by using the continuous emission monitoring system specified in paragraph (5) to measure sulfur dioxide and calculating a 24-hour daily geometric average emission concentration or a 24-hour daily geometric average percent reduction using EPA Reference Method 19, sections 4.3 and 5.4, as applicable.

(5) The owner or operator of an affected facility shall install, calibrate, maintain, and operate a continuous emission monitoring system for measuring sulfur dioxide emissions discharged to the atmosphere and record the output of the system.

(6) Following the date that the initial performance test for sulfur dioxide is completed or is required to be completed under 40 CFR 60.8, compliance with the sulfur dioxide emission limit shall be determined based on the 24-hour daily geometric average of the hourly arithmetic average emission concentrations using continuous emission monitoring system outlet data if compliance is based on an emission concentration, or continuous emission monitoring system inlet and outlet data if compliance is based on a percent reduction.

(7) At a minimum, valid continuous monitoring system hourly averages shall be obtained as specified in paragraphs (7)(i) and (7)(ii) for 75 percent of the operating hours per day for 90 percent of the operating days per calendar quarter that the affected facility is combusting municipal solid waste.

(i) At least two data points per hour shall be used to calculate each 1-hour arithmetic average.

(ii) Each sulfur dioxide 1-hour arithmetic average shall be corrected to 7 percent oxygen on an hourly basis using the 1-hour arithmetic average of the oxygen (or carbon dioxide) continuous emission monitoring system data.

(8) The 1-hour arithmetic averages required under paragraph (6) shall be expressed in parts per million corrected to 7 percent oxygen (dry basis) and used to calculate the 24-hour daily geometric average emission concentrations and daily geometric average emission percent reductions. The 1-hour arithmetic averages shall be calculated using the data points required under 40 CFR 60.13(e)(2).

(9) All valid continuous emission monitoring system data shall be used in calculating average emission concentrations and percent reductions even if the minimum continuous emission monitoring system data requirements of paragraph (7) are not met.

- (10) The procedures under 40 CFR 60.13 shall be followed for installation, evaluation and operation of the continuous emission monitoring system.
- (11) The initial performance evaluation shall be completed no later than 180 days after the date of initial startup of the municipal waste combustor as specified under 40 CFR 60.8.
- (12) The continuous emission monitoring system shall be operated according to Performance Specification 2 in 40 CFR 60 Appendix B.
- (i) During each relative accuracy test run of the continuous emission monitoring system required by Performance Specification 2 in 40 CFR 60 Appendix B, sulfur dioxide and oxygen (or carbon dioxide) data shall be collected concurrently (or within a 30- to 60-minute period) by both the continuous emission monitors and the test methods specified in paragraphs (A) and (B).
- (A) For sulfur dioxide, EPA Reference Method 6, 6A or 6C shall be used.
- (B) For oxygen (or carbon dioxide), EPA Reference Method 3, 3A, or 3B, as applicable shall be used.
- (ii) The span value of the continuous emissions monitoring system at the inlet to the sulfur dioxide control device shall be 125 percent of the maximum estimated hourly potential sulfur dioxide emissions of the municipal waste combustor unit. The span value of the continuous emission monitoring system at the outlet of the sulfur dioxide control device shall be 50 percent of the maximum estimated hourly potential sulfur dioxide emissions of the municipal waste combustor unit.
- (13) Quarterly accuracy determinations and daily calibration drift tests shall be performed in accordance with procedure 1 in Appendix F of 40 CFR 60.
- (14) When sulfur dioxide emissions data are not obtained because of continuous emission monitoring system breakdowns, repairs, calibration checks, and zero and span adjustments, emissions data shall be obtained by using other monitoring systems as approved by the Administrator or EPA Reference Method 19 to provide, as necessary, valid emissions data for a minimum of 75 percent of the hours per day that the affected facility is operated and combusting municipal solid waste for 90 percent of the days per calendar quarter that the affected facility is operated and combusting municipal solid waste.
[40 CFR 60.38b and 40 CFR 60.58b(e)]

Hydrogen Chloride

B.59. HCl stack tests upstream and downstream of the control device(s) shall be conducted to calculate percent control to demonstrate compliance with the alternate removal limit.
[PSD-FL-112(B)]

B.60. The procedures and test methods specified in paragraphs (1) through (8) shall be used for determining compliance with the hydrogen chloride emission limit.

- (1) The EPA Reference Method 26 or 26A, as applicable, shall be used to determine the hydrogen chloride emission concentration. The minimum sampling time for Method 26 shall be 1 hour.
- (2) An oxygen (or carbon dioxide) measurement shall be obtained simultaneously with each Method 26 test run for hydrogen chloride required by paragraph (1).
- (3) The percent reduction in potential hydrogen chloride emissions (% PHCl) is computed using equation 2:

$$[\%P_{HCl}] = \left[\frac{E_i - E_o}{E_i} \right] \times 100 \quad (\text{equation 2})$$

where:

%PHCl=percent reduction of the potential hydrogen chloride emissions achieved.

E_i =potential hydrogen chloride emission concentration measured at the control device inlet, corrected to 7 percent oxygen (dry basis).

E_o =controlled hydrogen chloride emission concentration measured at the control device outlet, corrected to 7 percent oxygen (dry basis).

- (4) The owner or operator of an affected facility may request that compliance with the hydrogen chloride emission limit be determined using carbon dioxide measurements corrected to an equivalent of 7 percent oxygen. The relationship between oxygen and carbon dioxide levels for the affected facility shall be established as specified in 40 CFR 60.58b(b)(6).
- (5) As specified under 40 CFR 60.8, all performance tests shall consist of three test runs. The average of the hydrogen chloride emission concentrations or percent reductions from the three test runs is used to determine compliance.
- (6) The owner or operator of an affected facility shall conduct an initial performance test for hydrogen chloride as required under 40 CFR 60.8.
- (7) Following the date that the initial performance test for hydrogen chloride is completed or is required to be completed under 40 CFR 60.8, the owner or operator of an affected facility shall conduct a performance test for hydrogen chloride emissions on an annual basis (no more than 12 calendar months following the previous performance test).
- (8) [reserved]
[40 CFR 60.38b and 40 CFR 60.58b(f)]

Dioxin/Furan

B.61. The procedures and test methods specified in paragraphs (1) through (9) shall be used to determine compliance with the limits for dioxin/furan emissions.

- (1) The EPA Reference Method 1 shall be used for determining the location and number of sampling points.
- (2) The EPA Reference Method 3, 3A, or 3B, as applicable, shall be used for flue gas analysis.
- (3) The EPA Reference Method 23 shall be used for determining the dioxin/furan emission concentration.
 - (i) The minimum sample time shall be 4 hours per test run.
 - (ii) An oxygen (or carbon dioxide) measurement shall be obtained simultaneously with each Method 23 test run for dioxins/furans.
- (4) The owner or operator of an affected facility shall conduct an initial performance test for dioxin/furan emissions in accordance with paragraph (3), as required under 40 CFR 60.8.
- (5) Following the date that the initial performance test for dioxins/furans is completed or is required to be completed under 40 CFR 60.8, the owner or operator of an affected facility shall conduct performance tests for dioxin/furan emissions in accordance with paragraph (3), according to one of the schedules specified in paragraphs (i) through (iii).
 - (i) For affected facilities, performance tests shall be conducted on an annual basis (no more than 12 calendar months following the previous performance test.)
 - (ii) [reserved]
 - (iii) Where all performance tests over a 2-year period indicate that dioxin/furan emissions are less than or equal to 15 nanograms per dry standard cubic meter (total mass), corrected to 7 percent oxygen, for all affected facilities located within a municipal waste combustor plant, the owner or operator of the municipal waste combustor plant may elect to conduct annual performance tests for

one affected facility (i.e., unit) per year at the municipal waste combustor plant. At a minimum, a performance test for dioxin/furan emissions shall be conducted annually (no more than 12 months following the previous performance test) for one affected facility at the municipal waste combustor plant. Each year a different affected facility at the municipal waste combustor plant shall be tested, and the affected facilities at the plant shall be tested in sequence (e.g., Unit 1, Unit 2, Unit 3, as applicable). If each annual performance test continues to indicate a dioxin/furan emission level less than or equal to 15 nanograms per dry standard cubic meter (total mass), corrected to 7 percent oxygen, the owner or operator may continue conducting a performance test on only one affected facility per year. If any annual performance test indicates a dioxin/furan emission level greater than 15 nanograms per dry standard cubic meter (total mass), corrected to 7 percent oxygen, performance tests thereafter shall be conducted annually on all affected facilities at the plant until and unless all annual performance tests for all affected facilities at the plant over a 2-year period indicate a dioxin/furan emission level less than or equal to 15 nanograms per dry standard cubic meter (total mass), corrected to 7 percent oxygen.

(6) The owner or operator of an affected facility that selects to follow the performance testing schedule specified in paragraph (5)(iii) shall follow the procedures specified in 40 CFR 60.59b(g)(4) for reporting the selection of this schedule.

(7) The owner or operator of an affected facility where activated carbon is used to comply with the dioxin/furan emission limits specified in 40 CFR 60.52b(c) or the dioxin/furan emission level specified in paragraph (5)(iii) shall follow the procedures specified in 40 CFR 60.58b(m) for measuring and calculating the carbon usage rate.

(8) The owner or operator of an affected facility may request that compliance with the dioxin/furan emission limit be determined using carbon dioxide measurements corrected to an equivalent of 7 percent oxygen. The relationship between oxygen and carbon dioxide levels for the affected facility shall be established as specified in 40 CFR 60.58b(b)(6).

(9) As specified under 40 CFR 60.8, all performance tests shall consist of three test runs. The average of the dioxin/furan emission concentrations from the three test runs is used to determine compliance.

[40 CFR 60.38b and 40 CFR 60.58b(g)]

Nitrogen Oxides

B.62. The procedures and test methods specified in paragraphs (1) through (12) shall be used to determine compliance with the nitrogen oxides emission limit for affected facilities under 40 CFR 60.52b(d).

(1) The EPA Reference Method 19, section 4.1, shall be used for determining the daily arithmetic average nitrogen oxides emission concentration.

(2) The owner or operator of an affected facility may request that compliance with the nitrogen oxides emission limit be determined using carbon dioxide measurements corrected to an equivalent of 7 percent oxygen. The relationship between oxygen and carbon dioxide levels for the affected facility shall be established as specified in 40 CFR 60.58b(b)(6).

(3) The owner or operator of an affected facility subject to the nitrogen oxides limit shall conduct an initial performance test for nitrogen oxides as required under 40 CFR 60.8. Compliance with the nitrogen oxides emission limit shall be determined by using the continuous emission monitoring system specified in paragraph (4) for measuring nitrogen oxides and calculating a 24-hour daily arithmetic average emission concentration using EPA Reference Method 19, section 4.1.

(4) The owner or operator of an affected facility subject to the nitrogen oxides emission shall install, calibrate, maintain, and operate a continuous emission monitoring system for measuring nitrogen oxides discharged to the atmosphere, and record the output of the system.

- (5) Following the date that the initial performance test for nitrogen oxides is completed or is required to be completed under 40 CFR 60.8, compliance with the emission limit for nitrogen oxides shall be determined based on the 24-hour daily arithmetic average of the hourly emission concentrations using continuous emission monitoring system outlet data.
- (6) At a minimum, valid continuous emission monitoring system hourly averages shall be obtained as specified in paragraphs (i) and (ii) for 75 percent of the operating hours per day for 90 percent of the operating days per calendar quarter that the affected facility is combusting municipal solid waste.
- (i) At least 2 data points per hour shall be used to calculate each 1-hour arithmetic average.
 - (ii) Each nitrogen oxides 1-hour arithmetic average shall be corrected to 7 percent oxygen on an hourly basis using the 1-hour arithmetic average of the oxygen (or carbon dioxide) continuous emission monitoring system data.
- (7) The 1-hour arithmetic averages required by paragraph (5) shall be expressed in parts per million by volume (dry basis) and used to calculate the 24-hour daily arithmetic average concentrations. The 1-hour arithmetic averages shall be calculated using the data points required under 40 CFR 60.13(e)(2).
- (8) All valid continuous emission monitoring system data must be used in calculating emission averages even if the minimum continuous emission monitoring system data requirements of paragraph (6) are not met.
- (9) The procedures under 40 CFR 60.13 shall be followed for installation, evaluation, and operation of the continuous emission monitoring system. The initial performance evaluation shall be completed no later than 180 days after the date of initial startup of the municipal waste combustor unit, as specified under 40 CFR 60.8.
- (10) The owner or operator of an affected facility shall operate the continuous emission monitoring system according to Performance Specification 2 in Appendix B of 40 CFR 60 and shall follow the procedures and methods specified in paragraphs(i) and (ii).
- (i) During each relative accuracy test run of the continuous emission monitoring system required by Performance Specification 2 of Appendix B of 40 CFR 60, nitrogen oxides and oxygen (or carbon dioxide) data shall be collected concurrently (or within a 30- to 60-minute period) by both the continuous emission monitors and the test methods specified in paragraphs(A) and (B).
 - (A) For nitrogen oxides, EPA Reference Method 7, 7A, 7C, 7D or 7E shall be used.
 - (B) For oxygen (or carbon dioxide), EPA Reference Method 3, 3A or 3B, as applicable shall be used.
 - (ii) The span value of the continuous emission monitoring system shall be 125 percent of the maximum estimated hourly potential nitrogen oxide emissions of the municipal waste combustor unit.
- (11) Quarterly accuracy determinations and daily calibration drift tests shall be performed in accordance with procedure 1 in Appendix F of 40 CFR 60.
- (12) When nitrogen oxides continuous emissions data are not obtained because of continuous emission monitoring system breakdowns, repairs, calibration checks, and zero and span adjustments, emissions data shall be obtained using other monitoring systems as approved by the Administrator or EPA Reference Method 19 to provide, as necessary, valid emissions data for a minimum of 75 percent of the hours per day for 90 percent of the days per calendar quarter the unit is operated and combusting municipal solid waste.
- [40 CFR 60.38b and 40 CFR 60.58b(h)]

Carbon Monoxide

B.63. See specific condition B.21.
[Rule 62-213.440, F.A.C.]

Fugitive Ash

B.64. The procedures specified in paragraphs (1) through (4) shall be used for determining compliance with the fugitive ash emission limit under 40 CFR 60.55b.

(1) The EPA Reference Method 22 shall be used for determining compliance with the fugitive ash emission limit under 40 CFR 60.55b. The minimum observation time shall be a series of three 1-hour observations. The observation period shall include times when the facility is transferring ash from the municipal waste combustor unit to the area where ash is stored or loaded into containers or trucks.

(2) The average duration of visible emissions per hour shall be calculated from the three 1-hour observations. The average shall be used to determine compliance with 40 CFR 60.55b.

(3) The owner or operator of an affected facility shall conduct an initial performance test for fugitive ash emissions as required under 40 CFR 60.8.

(4) Following the date that the initial performance test for fugitive ash emissions is completed or is required to be completed under 40 CFR 60.8 for an affected facility, the owner or operator shall conduct a performance test for fugitive ash emissions on an annual basis (no more than 12 calendar months following the previous performance test).

[40 CFR 60.38b and 40 CFR 60.58b(k)]

Beryllium

B.65. The test method for beryllium emissions shall be EPA Method 29, adopted and incorporated by reference in Rule 62-204.800, F.A.C. One sample shall constitute one test run.

[PSD-FL-112(B)]

Total Fluoride

B.66. The test method for total fluoride emissions shall be EPA Method 13A, 13B, or modified Method 5 for fluorides, adopted and incorporated by reference in Rule 62-204.800, F.A.C. One sample shall constitute one test run.

[PSD-FL-112(B); and, PA 86-22]

B.67. Reserved

B.68. Reserved

B.69. Required Number of Test Runs. For mass emission limitations, a compliance test shall consist of three complete and separate determinations of the total air pollutant emission rate through the test section of the stack or duct and three complete and separate determinations of any applicable process variables corresponding to the three distinct time periods during which the stack emission rate was measured provided, however, that three complete and separate determinations shall not be required if the process variables are not subject to variation during a compliance test, or if three determinations are not necessary in order to calculate the unit's emission rate. The three required test runs shall be completed within one consecutive five day period. In the event that a sample is lost or one of the three runs must be discontinued because of circumstances beyond the control of the owner or operator, and a valid third run cannot be obtained within the five day period allowed for the test, the Secretary or his or her designee may accept the results of the two complete runs as proof of compliance, provided that the arithmetic mean of the results of the two complete runs is at least 20 percent below the allowable emission limiting standards.

[Rule 62-297.310(1), F.A.C.]

B.70. Operating Rate During Testing. Testing of emissions shall be conducted with the emissions unit operation at permitted capacity, which is defined as 90 to 100 percent of the maximum operation rate allowed by the permit. If it is impracticable to test at permitted capacity, an emissions unit may be tested at less than the minimum permitted capacity; in this case, subsequent emissions unit operation is limited to 110 percent of the test load until a new test is conducted. Once the emissions unit is so limited, operation at higher capacities is allowed for no more than 15 consecutive days for the purpose of additional compliance testing to regain the authority to operate at the permitted capacity.
[Rules 62-297.310(2) & (2)(b), F.A.C.]

B.71. Calculation of Emission Rate. The indicated emission rate or concentration shall be the arithmetic average of the emission rate or concentration determined by each of the three separate test runs unless otherwise specified in a particular test method or applicable rule.
[Rule 62-297.310(3), F.A.C.]

B.72. Applicable Test Procedures.

(a) Required Sampling Time.

1. Unless otherwise specified in the applicable rule, the required sampling time for each test run shall be no less than one hour and no greater than four hours, and the sampling time at each sampling point shall be of equal intervals of at least two minutes.

2. **Opacity Compliance Tests.** When either EPA Method 9 or DEP Method 9 is specified as the applicable opacity test method, the required minimum period of observation for a compliance test shall be sixty (60) minutes for emissions units which emit or have the potential to emit 100 tons per year or more of particulate matter, and thirty (30) minutes for emissions units which have potential emissions less than 100 tons per year of particulate matter and are not subject to a multiple-valued opacity standard. The opacity test observation period shall include the period during which the highest opacity emissions can reasonably be expected to occur. Exceptions to these requirements are as follows:

a. For batch, cyclical processes, or other operations which are normally completed within less than the minimum observation period and do not recur within that time, the period of observation shall be equal to the duration of the batch cycle or operation completion time.

b. The observation period for special opacity tests that are conducted to provide data to establish a surrogate standard pursuant to Rule 62-297.310(5)(k), F.A.C., Waiver of Compliance Test Requirements, shall be established as necessary to properly establish the relationship between a proposed surrogate standard and an existing mass emission limiting standard.

c. The minimum observation period for opacity tests conducted by employees or agents of the Department to verify the day-to-day continuing compliance of a unit or activity with an applicable opacity standard shall be twelve minutes.

(b) Minimum Sample Volume. Unless otherwise specified in the applicable rule, the minimum sample volume per run shall be 25 dry standard cubic feet. (See specific conditions B.54. and B.55.)

(c) Required Flow Rate Range. For EPA Method 5 particulate sampling, acid mist/sulfur dioxide, and fluoride sampling which uses Greenburg Smith type impingers, the sampling nozzle and sampling time shall be selected such that the average sampling rate will be between 0.5 and 1.0 actual cubic feet per minute, and the required minimum sampling volume will be obtained.

(d) Calibration of Sampling Equipment. Calibration of the sampling train equipment shall be conducted in accordance with the schedule shown in Table 297.310-1, attached as part of this permit.

(e) Allowed Modification to EPA Method 5. When EPA Method 5 is required, the following modification is allowed: the heated filter may be separated from the impingers by a flexible tube.

[Rule 62-297.310(4), F.A.C.]

B.73. Required Stack Sampling Facilities. When a mass emissions stack test is required, the permittee shall comply with the requirements contained in Appendix SS-1, Stack Sampling Facilities, attached to this permit.

[Rule 62-297.310(6), F.A.C.]

B.74. Frequency of Compliance Tests. The following provisions apply only to those emissions units that are subject to an emissions limiting standard for which compliance testing is required.

(a) **General Compliance Testing.**

3. The owner or operator of an emissions unit that is subject to any emission limiting standard shall conduct a compliance test that demonstrates compliance with the applicable emission limiting standard prior to obtaining a renewed operation permit. Emissions units that are required to conduct an annual compliance test may submit the most recent annual compliance test to satisfy the requirements of this provision. In renewing an air operation permit pursuant to Rule 62-210.300(2)(a)3.b., c., or d., F.A.C., the Department shall not require submission of emission compliance test results for any emissions unit that, during the year prior to renewal:

- a. Did not operate; or
- b. In the case of a fuel burning emissions unit, burned liquid and/or solid fuel for a total of no more than 400 hours.

4. During each federal fiscal year (October 1 - September 30), unless otherwise specified by rule, order, or permit, the owner or operator of each emissions unit shall have a formal compliance test conducted for:

- a. Visible emissions, if there is an applicable standard;
- b. Each of the following pollutants, if there is an applicable standard, and if the emissions unit emits or has the potential to emit: 5 tons per year or more of lead or lead compounds measured as elemental lead; 30 tons per year or more of acrylonitrile; or 100 tons per year or more of any other regulated air pollutant; and
- c. Each NESHAP pollutant, if there is an applicable emission standard.

5. An annual compliance test for particulate matter emissions shall not be required for any fuel burning emissions unit that, in a federal fiscal year, does not burn liquid and/or solid fuel, other than during startup, for a total of more than 400 hours.

9. The owner or operator shall notify the DEP Southeast District Office, at least 15 days prior to the date on which each formal compliance test is to begin, of the date, time, and place of each such test, and the test contact person who will be responsible for coordinating and having such test conducted for the owner or operator.

(b) **Special Compliance Tests.** When the DEP Southeast District Office, after investigation, has good reason (such as complaints, increased visible emissions or questionable maintenance of control equipment) to believe that any applicable emission standard contained in a Department rule or in a permit issued pursuant to those rules is being violated, it may require the owner or operator of the emissions unit to conduct compliance tests which identify the nature and quantity of pollutant emissions from the emissions unit and to provide a report on the results of said tests to the DEP Southeast District Office.

(c) **Waiver of Compliance Test Requirements.** If the owner or operator of an emissions unit that is subject to a compliance test requirement demonstrates to the Department, pursuant to the procedure established in Rule 62-297.620, F.A.C., that the compliance of the emissions unit with an applicable weight emission limiting standard can be adequately determined by means other than the designated test procedure, such as specifying a surrogate standard of no visible emissions for particulate matter sources equipped with a bag house or specifying a fuel analysis for sulfur dioxide emissions, the Department shall waive the compliance test requirements for such emissions units and order that the alternate means of

determining compliance be used, provided, however, the provisions of Rule 62-297.310(7)(b), F.A.C., shall apply.

[Rule 62-297.310(7), F.A.C.; and, SIP approved]

Compliance With Standards and Maintenance Requirements

B.75. Compliance with standards in 40 CFR 60, other than opacity standards, shall be determined by performance tests established by 40 CFR 60.8, unless otherwise specified in the applicable standard.

[40 CFR 60.11(a)]

B.76. Compliance with opacity standards in 40 CFR 60 shall be determined by conducting observations in accordance with Reference Method 9 in Appendix A of 40 CFR 60, any alternative method that is approved by the Administrator, or as provided in 40 CFR 60.11(e)(5).

[40 CFR 60.11(b)]

B.77. The owner or operator of an affected facility subject to an opacity standard may submit, for compliance purposes, continuous opacity monitoring system (COMS) data results produced during any performance test required under 40 CFR 60.8 in lieu of EPA Method 9 observation data. If an owner or operator elects to submit COMS data for compliance with the opacity standard, he or she shall notify the Administrator of that decision, in writing, at least 30 days before any performance test required under 40 CFR 60.8 is conducted. Once the owner or operator of an affected facility has notified the Administrator to that effect, the COMS data results will be used to determine opacity compliance during subsequent tests required under 40 CFR 60.8 until the owner or operator notifies the Administrator, in writing, to the contrary. For the purpose of determining compliance with the opacity standard during a performance test required under 40 CFR 60.8 using COMS data, the minimum total time of COMS data collection shall be averages of all 6-minute continuous periods within the duration of the mass emission performance test. Results of the COMS opacity determinations shall be submitted along with the results of the performance test required under 60.8. The owner or operator of an affected facility using a COMS for compliance purposes is responsible for demonstrating that the COMS meets the requirements specified in 40 CFR 60.13(c), that the COMS has been properly maintained and operated, and that the resulting data have not been altered in any way. If COMS data results are submitted for compliance with the opacity standard for a period of time during which EPA Method 9 data indicates noncompliance, the EPA Method 9 data will be used to determine opacity compliance.

[40 CFR 60.11(e)(5)]

B.78. Compliance with the emission limit in lb/mmBtu (see specific condition B.40.) shall be determined by calculating an EPA F-Factor using 40 CFR 60 Appendix A, Method 19.

[Rule 62-213.440, F.A.C.]

B.79. Continuous compliance with the emission limits for opacity, carbon monoxide (CO), nitrogen oxides (NO_x), sulfur dioxide (SO₂) and the operational parameters steam production (lb/hr) or feedwater flow rate (lb/hr) and fabric filter inlet flue gas temperature shall be demonstrated by continuous emission monitoring systems (CEMS) operated in accordance with 40 CFR 60.58b and 60.59b(f). SO₂ monitors shall be located both upstream of the scrubber and downstream of the baghouse, in order to calculate percent removal efficiency. (See Specific Condition B.58.)

[PSD-FL-112(B)]

B.80. Each MWC unit is required to continuously monitor and record the flue gas temperature at the inlet to the PM control device in accordance with the requirements at 40 CFR 60.58b(i)(7). The PM control

device inlet temperature and the steam (or feedwater) flow for each unit during the stack test shall be continuously monitored and recorded in accordance with 40 CFR 60, Subpart Cb. Higher temperatures are allowed for testing purposes, as specified at 40 CFR 60.53b(c).
[PSD-FL-112(B)]

Monitoring Requirements

B.81. For the purposes of 40 CFR 60.13, all continuous monitoring systems (CMS) required under applicable subparts shall be subject to the provisions of 40 CFR 60.13 upon promulgation of performance specifications for continuous monitoring systems under Appendix B of 40 CFR 60 and, if the continuous monitoring system is used to demonstrate compliance with emission limits on a continuous basis, Appendix F of 40 CFR 60, unless otherwise specified in an applicable subpart or by the Administrator. Appendix F is applicable December 4, 1987.
[40 CFR 60.13(a)]

B.82. If the owner or operator of an affected facility elects to submit continuous opacity monitoring system (COMS) data for compliance with the opacity standard as provided under 40 CFR 60.11(e)(5), he shall conduct a performance evaluation of the COMS as specified in Performance Specification 1, Appendix B, of 40 CFR 60 before the performance test required under 40 CFR 60.8 is conducted. Otherwise, the owner or operator of an affected facility shall conduct a performance evaluation of the COMS or continuous emission monitoring system (CEMS) during any performance test required under 40 CFR 60.8 or within 30 days thereafter in accordance with the applicable performance specification in Appendix B of 40 CFR 60. The owner or operator of an affected facility shall conduct COMS or CEMS performance evaluations at such other times as may be required by the Administrator under section 114 of the Act.

(1) The owner or operator of an affected facility using a COMS to determine opacity compliance during any performance test required under 40 CFR 60.8, and as described in 40 CFR 60.11(e)(5), shall furnish the Administrator two or, upon request, more copies of a written report of the results of the COMS performance evaluation described in 40 CFR 60.13(c) at least 10 days before the performance test required under 40 CFR 60.8 is conducted.
[40 CFR 60.13(c)(1)]

B.83. (1) Owners and operators of all continuous emission monitoring systems (CEMS) installed in accordance with the provisions of this part shall check the zero (or low-level value between 0 and 20 percent of span value) and span (50 to 100 percent of span value) calibration drifts at least once daily in accordance with a written procedure. The zero and span shall, as a minimum, be adjusted whenever the 24-hour zero drift or 24-hour span drift exceeds two times the limits of the applicable performance specifications in Appendix B. The system must allow the amount of excess zero and span drift measured at the 24-hour interval checks to be recorded and quantified, whenever specified. For continuous monitoring systems measuring opacity of emissions, the optical surfaces exposed to the effluent gases shall be cleaned prior to performing the zero and span drift adjustments except that for systems using automatic zero adjustments. The optical surfaces shall be cleaned when the cumulative automatic zero compensation exceeds 4 percent opacity.

(2) Unless otherwise approved by the Administrator, the following procedures shall be followed for continuous monitoring systems measuring opacity of emissions. Minimum procedures shall include a method for producing a simulated zero opacity condition and an upscale (span) opacity condition using a

certified neutral density filter or other related technique to produce a known obscuration of the light beam. Such procedures shall provide a system check of the analyzer internal optical surfaces and all electronic circuitry including the lamp and photo detector assembly.

[40 CFR 60.13(d)(1) and (2)]

B.84. Except for system breakdowns, repairs, calibration checks, and zero and span adjustments required under 40 CFR 60.13(d), all continuous monitoring systems (CMS) shall be in continuous operation and shall meet minimum frequency of operation requirements as follows:

(1) All continuous monitoring systems referenced by 40 CFR 60.13(c) for measuring opacity of emissions shall complete a minimum of one cycle of sampling and analyzing for each successive 10-second period and one cycle of data recording for each successive 6-minute period.

(2) All continuous monitoring systems referenced by 40 CFR 60.13(c) for measuring emissions, except opacity, shall complete a minimum of one cycle of operation (sampling, analyzing, and data recording) for each successive 15-minute period.

[40 CFR 60.13(e)(1) and (2)]

B.85. All continuous monitoring systems (CMS) or monitoring devices shall be installed such that representative measurements of emissions or process parameters from the affected facility are obtained. Additional procedures for location of continuous monitoring systems contained in the applicable Performance Specifications of Appendix B of 40 CFR 60 shall be used.

[40 CFR 60.13(f)]

B.86. When the effluents from a single affected facility or two or more affected facilities subject to the same emission standards are combined before being released to the atmosphere, the owner or operator may install applicable continuous monitoring systems (CMS) on each effluent or on the combined effluent. When the affected facilities are not subject to the same emission standards, separate continuous monitoring systems shall be installed on each effluent. When the effluent from one affected facility is released to the atmosphere through more than one point, the owner or operator shall install an applicable continuous monitoring system on each separate effluent unless the installation of fewer systems is approved by the Administrator. When more than one continuous monitoring system is used to measure the emissions from one affected facility (e.g., multiple breechings, multiple outlets), the owner or operator shall report the results as required from each continuous monitoring system.

[40 CFR 60.13(g)]

B.87. Owners or operators of all continuous monitoring systems for measurement of opacity shall reduce all data to 6-minute averages and for continuous monitoring systems other than opacity to 1-hour averages for time periods as defined in 40 CFR 60.2. Six-minute opacity averages shall be calculated from 36 or more data points equally spaced over each 6-minute period. For continuous monitoring systems other than opacity, 1-hour averages shall be computed from four or more data points equally spaced over each 1-hour period. Data recorded during periods of continuous monitoring system breakdowns, repairs, calibration checks, and zero and span adjustments shall not be included in the data averages computed under this paragraph. An arithmetic or integrated average of all data may be used. The data may be recorded in reduced or non reduced form (e.g., ppm pollutant and percent O₂ or ng/J of pollutant). All excess emissions shall be converted into units of the standard using the applicable conversion procedures specified in subparts. After conversion into units of the standard, the data may be rounded to the same number of significant digits as used in the applicable subparts to specify the emission limit (e.g., rounded to the nearest 1 percent opacity).

[40 CFR 60.13(h)]

B.88. Determination of Process Variables.

(a) Required Equipment. The owner or operator of an emissions unit for which compliance tests are required shall install, operate, and maintain equipment or instruments necessary to determine process variables, such as process weight input or heat input, when such data are needed in conjunction with emissions data to determine the compliance of the emissions unit with applicable emission limiting standards.

(b) Accuracy of Equipment. Equipment or instruments used to directly or indirectly determine process variables, including devices such as belt scales, weight hoppers, flow meters, and tank scales, shall be calibrated and adjusted to indicate the true value of the parameter being measured with sufficient accuracy to allow the applicable process variable to be determined within 10% of its true value.

[Rule 62-297.310(5), F.A.C.]

CEM for Oxygen or Carbon Dioxide

B.89. The owner or operator of an affected facility shall install, calibrate, maintain and operate a continuous emission monitoring system and record the output of the system for measuring the oxygen or carbon dioxide content of the flue gas at each location where carbon monoxide, sulfur dioxide or nitrogen oxides emissions are monitored and shall comply with the test procedures and test methods specified in paragraphs (1) through (7).

(1) The span value of the oxygen (or carbon dioxide) monitor shall be 25 percent oxygen (or carbon dioxide).

(2) The monitor shall be installed, evaluated, and operated in accordance with 40 CFR 60.13.

(3) The initial performance evaluation shall be completed no later than 180 days after the date of initial startup of the affected facility, as specified under 40 CFR 60.8.

(4) The monitor shall conform to Performance Specification 3 in Appendix B of 40 CFR 60, except for section 2.3 (relative accuracy requirement).

(5) The quality assurance procedures of Appendix F of 40 CFR 60, except for section 5.1.1 (relative accuracy test audit), shall apply to the monitor.

(6) If carbon dioxide is selected for use in diluent corrections, the relationship between oxygen and carbon dioxide levels shall be established during the initial performance test according to the procedures and methods specified in paragraphs(i) through(iv). This relationship may be reestablished during performance compliance tests.

(i) The fuel factor equation in Method 3B shall be used to determine the relationship between oxygen and carbon dioxide at a sampling location. Method 3, 3A or 3B, as applicable, shall be used to determine the oxygen concentration at the same location as the carbon dioxide monitor.

(ii) Samples shall be taken for at least 30 minutes in each hour.

(iii) Each sample shall represent a 1-hour average.

(iv) A minimum of three runs shall be performed.

(7) The relationship between carbon dioxide and oxygen concentrations that is established in accordance with paragraph (6) shall be submitted to the EPA Administrator as part of the initial performance test report and, if applicable, as part of the annual test report if the relationship is reestablished during the annual performance test.

[40 CFR 60.38b and 40 CFR 60.58b(b)]

Recordkeeping and Reporting Requirements

B.90. The owner or operator subject to the provisions of 40 CFR 60 shall furnish the Administrator written notification as follows:

(4) A notification of any physical or operational change to an existing facility which may increase the emission rate of any air pollutant to which a standard applies, unless that change is specifically exempted under an applicable subpart or in 40 CFR 60.14(e). This notice shall be postmarked 60 days, or as soon as practicable, before the change is commenced and shall include information describing the precise nature of the change, present and proposed emission control systems, productive capacity of the facility before and after the change, and the expected completion date of the change. The Administrator may request additional relevant information subsequent to this notice.

[40 CFR 60.7(a)(4)]

B.91. The owner or operator subject to the provisions of 40 CFR 60 shall maintain records of the occurrence and duration of any startup, shutdown, or malfunction in the operation of an affected facility; any malfunction of the air pollution control equipment; or, any periods during which a continuous monitoring system or monitoring device is inoperative.

[40 CFR 60.7(b)]

B.92. Excess Emissions Report. An excess emissions report shall be submitted to EPA for every calendar quarter. The report shall include the following:

(1) The magnitude of excess emissions computed in accordance with 40 CFR 60.13(h) (see specific condition **B.87.**), any conversion factors used, and the date and time of commencement and completion of each period of excess emissions (40 CFR 60.7(c)(1)).

(2) Specific identification of each period of excess emissions that occurs during startups, shutdowns, and malfunctions of the furnace/boiler system. The nature and cause of any malfunction (if known) and the corrective action taken or preventative measures adopted shall also be reported (40 CFR 60.7(c)(2)).

(3) The date and time identifying each period during which the continuous monitoring system was inoperative except for zero and span checks, and the nature of the system repairs or adjustments (40 CFR 60.7(c)(3)).

(4) When no excess emissions have occurred or the continuous monitoring system has not been inoperative, repaired, or adjusted, such information shall be stated in the report (40 CFR 60.7(c)(4)).

(5) Permittee shall maintain a file of all measurements, including continuous monitoring systems performance evaluations; all continuous monitoring systems or monitoring device calibration checks; adjustments and maintenance performed on these systems or devices; and all other information required by this permit recorded in a permanent form suitable for inspection (40 CFR 60.7(d)).

(6) Excess emissions shall be defined as any applicable period during which the average emissions of CO, NO_x, and/or SO₂, as measured by the continuous monitoring system, exceeds the CO, NO_x, and/or SO₂ maximum emission limit (in ppm) or percent removal efficiency, as applicable, set for each pollutant in specific conditions **B.32.**, **B.36.** and **B.37.** above.

[PSD-FL-112(B); Rule 62-213.440, F.A.C.]

B.93. The summary report form shall contain the information and be in the format shown in Figure 1 (attached) unless otherwise specified by the Administrator. One summary report form shall be submitted for each pollutant monitored at each affected facility.

(1) If the total duration of excess emissions for the reporting period is less than 1 percent of the total operating time for the reporting period and CMS downtime for the reporting period is less than 5 percent of the total operating time for the reporting period, only the summary report form shall be submitted and the excess emission report described in 40 CFR 60.7(c) need not be submitted unless requested by the Administrator.

(2) If the total duration of excess emissions for the reporting period is 1 percent or greater of the total operating time for the reporting period or the total CMS downtime for the reporting period is 5 percent or greater of the total operating time for the reporting period, the summary report form and the excess emission report described in 40 CFR 60.7(c) shall both be submitted.

{See attached Figure 1: Summary Report-Gaseous and Opacity Excess Emission and Monitoring System Performance}

[40 CFR 60.7(d)(1) and (2)]

B.94. (1) Notwithstanding the frequency of reporting requirements specified in 40 CFR 60.7(c), an owner or operator who is required by an applicable subpart to submit excess emissions and monitoring systems performance reports (and summary reports) on a quarterly (or more frequent) basis may reduce the frequency of reporting for that standard to semiannual if the following conditions are met:

- (i) For 1 full year (e.g., 4 quarterly or 12 monthly reporting periods) the affected facility's excess emissions and monitoring systems reports submitted to comply with a standard under this part continually demonstrate that the facility is in compliance with the applicable standard;
- (ii) The owner or operator continues to comply with all recordkeeping and monitoring requirements specified in 40 CFR 60, Subpart A, and the applicable standard; and
- (iii) The Administrator does not object to a reduced frequency of reporting for the affected facility, as provided in 40 CFR 60.7(e)(2).

(2) The frequency of reporting of excess emissions and monitoring systems performance (and summary) reports may be reduced only after the owner or operator notifies the Administrator in writing of his or her intention to make such a change and the Administrator does not object to the intended change. In deciding whether to approve a reduced frequency of reporting, the Administrator may review information concerning the source's entire previous performance history during the required recordkeeping period prior to the intended change, including performance test results, monitoring data, and evaluations of an owner or operator's conformance with operation and maintenance requirements. Such information may be used by the Administrator to make a judgment about the source's potential for noncompliance in the future. If the Administrator disapproves the owner or operator's request to reduce the frequency of reporting, the Administrator will notify the owner or operator in writing within 45 days after receiving notice of the owner or operator's intention. The notification from the Administrator to the owner or operator will specify the grounds on which the disapproval is based. In the absence of a notice of disapproval within 45 days, approval is automatically granted.

(3) As soon as monitoring data indicate that the affected facility is not in compliance with any emission limitation or operating parameter specified in the applicable standard, the frequency of reporting shall revert to the frequency specified in the applicable standard, and the owner or operator shall submit an excess emissions and monitoring systems performance report (and summary report, if required) at the next appropriate reporting period following the noncomplying event. After demonstrating compliance with the applicable standard for another full year, the owner or operator may again request approval from the Administrator to reduce the frequency of reporting for that standard as provided for in 40 CFR 60.7(e)(1) and (e)(2).

[40 CFR 60.7(e)(1), (2), and (3)]

B.95. Any owner or operator subject to the provisions of 40 CFR 60 shall maintain a file of all measurements, including continuous monitoring system, monitoring device, and performance testing measurements; all continuous monitoring system performance evaluations; all continuous monitoring system or monitoring device calibration checks; adjustments and maintenance performed on these systems or devices; and, all other information required by 40 CFR 60 recorded in a permanent form suitable for inspection. The file shall be retained for at least 5 (five) years following the date of such measurements, maintenance, reports, and records.

[40 CFR 60.7(f); Rule 62-213.440(1)(b)2.b., F.A.C.]

B.96. Notification of Construction or Reconstruction. The owner or operator of an affected facility with a capacity to combust greater than 250 tons per day shall submit a notification of construction, which includes the information specified in paragraphs (1) through (4).

- (1) Intent to construct.
- (2) Planned initial startup date.
- (3) The types of fuels that the owner or operator plans to combust in the affected facility.
- (4) The municipal waste combustor unit capacity and supporting capacity calculations prepared in accordance with 40 CFR 60.58b(j).
[40 CFR 60.39b and 40 CFR 60.59b(b)]

B.97. The owner or operator of an affected facility subject to the standards under 40 CFR. 60.53b, 60.54b and 60.55b shall maintain records of the information specified in paragraphs (1) through (15), as applicable, for each affected facility for a period of at least 5 years.

- (1) The calendar date of each record.
- (2) The emission concentrations and parameters measured using continuous monitoring systems as specified under paragraphs (i) and (ii).
 - (i) The measurements specified in paragraphs (A) through (D) shall be recorded and be available for submittal to the Administrator or review onsite by an inspector.
 - (A) All 6-minute average opacity levels as specified under 40 CFR 60.58b(c).
 - (B) All 1-hour average sulfur dioxide emission concentrations as specified under 40 CFR 60.58b(e).
 - (C) All 1-hour average nitrogen oxides emission concentrations as specified under 40 CFR 60.58b(h).
 - (D) All 1-hour average carbon monoxide emission concentrations, municipal waste combustor unit load measurements, and particulate matter control device inlet temperatures as specified under 40 CFR 60.58b(i).
 - (ii) The average concentrations and percent reductions, as applicable, specified in paragraphs (2)(ii)(A) through (2)(ii)(D) shall be computed and recorded, and shall be available for submittal to the Administrator or review on-site by an inspector.
 - (A) All 24-hour daily geometric average sulfur dioxide emission concentrations and all 24-hour daily geometric average percent reductions in sulfur dioxide emissions as specified under 40 CFR 60.58b(e).
 - (B) All 24-hour daily arithmetic average nitrogen oxides emission concentrations as specified under 40 CFR 60.58b(h).
 - (C) All 4-hour block or 24-hour daily arithmetic average carbon monoxide emission concentrations, as applicable, as specified under 40 CFR 60.58b(i).
 - (D) All 4-hour block arithmetic average municipal waste combustor unit load levels and particulate matter control device inlet temperatures as specified under 40 CFR 60.58b(i).
- (3) Identification of the calendar dates when any of the average emission concentrations, percent reductions, or operating parameters recorded under paragraphs (2)(ii)(A) through (2)(ii)(D), or the opacity levels recorded under paragraph (2)(i)(A) are above the applicable limits, with reasons for such exceedances and a description of corrective actions taken.
- (5) [Reserved]
- (6) Identification of the calendar dates for which the minimum number of hours of any of the data specified in paragraphs (i) through (v) have not been obtained including reasons for not obtaining sufficient data and a description of corrective actions taken.
 - (i) Sulfur dioxide emissions data;
 - (ii) Nitrogen oxides emissions data;
 - (iii) Carbon monoxide emissions data;

- (iv) Municipal waste combustor unit load data; and
 - (v) Particulate matter control device temperature data.
- (7) Identification of each occurrence that sulfur dioxide emissions data, nitrogen oxides emissions data (large municipal waste combustors only), or operational data (i.e., carbon monoxide emissions, unit load, and particulate matter control device temperature) have been excluded from the calculation of average emission concentrations or parameters, and the reasons for excluding the data.
- (8) The results of daily drift tests and quarterly accuracy determinations for sulfur dioxide, nitrogen oxides, and carbon monoxide continuous emission monitoring systems, as required under Appendix F of 40 CFR 60, procedure 1.
- (9) The test reports documenting the results of the initial performance test and all annual performance tests listed in paragraphs (i) and (ii) shall be recorded along with supporting calculations.
- (i) The results of the initial performance test and all annual performance tests conducted to determine compliance with the particulate matter, opacity, cadmium, lead, mercury, dioxins/furans, hydrogen chloride, and fugitive ash emission limits.
 - (ii) For the initial dioxin/furan performance test and all subsequent dioxin/furan performance tests recorded under paragraph (9)(i), the maximum demonstrated municipal waste combustor unit load and maximum demonstrated particulate matter control device temperature (for each particulate matter control device).
- (10) [Reserved]
- (12) The records specified in paragraphs (i) through (iii).
- (i) Records showing the names of the municipal waste combustor chief facility operator, shift supervisors, and control room operators who have been provisionally certified by the American Society of Mechanical Engineers or an equivalent State-approved certification program as required by 40 CFR 60.54b(a) including the dates of initial and renewal certifications and documentation of current certification.
 - (ii) Records showing the names of the municipal waste combustor chief facility operator, shift supervisors, and control room operators who have been fully certified by the American Society of Mechanical Engineers or an equivalent State-approved certification program as required by 40 CFR 60.54b(b) including the dates of initial and renewal certifications and documentation of current certification.
 - (iii) Records showing the names of the municipal waste combustor chief facility operator, shift supervisors, and control room operators who have completed the EPA municipal waste combustor operator training course or a State-approved equivalent course as required by 40 CFR 60.54b(d) including documentation of training completion.
- (13) Records showing the names of persons who have completed a review of the operating manual as required by 40 CFR 60.54b(f) including the date of the initial review and subsequent annual reviews.
- (14) For affected facilities that apply activated carbon for mercury or dioxin/furan control, identification of the calendar dates when the average carbon mass feed rates recorded under (4)(iii) were less than either of the hourly carbon feed rates estimated during performance tests for mercury or dioxin/furan emissions and recorded under paragraphs (4)(i) and (4)(ii), respectively, with reasons for such feed rates and a description of corrective actions taken.
- [40 CFR 60.39b and 40 CFR 60.59b(d)]

B.98. The owner or operator of an affected facility shall submit the information specified in paragraphs (1) through (6) in the initial performance test report.

- (1) The initial performance test data as recorded under 40 CFR 60.59b(d)(2)(ii)(A) through (d)(2)(ii)(D) for the initial performance test for sulfur dioxide, nitrogen oxides, carbon monoxide, municipal waste combustor unit load level, and particulate matter control device inlet temperature.

(2) The test report documenting the initial performance test recorded under 40 CFR 60.59b(d)(9) for particulate matter, opacity, cadmium, lead, mercury, dioxins/furans, hydrogen chloride, and fugitive ash emissions.

(3) The performance evaluation of the continuous emission monitoring system using the applicable performance specifications in Appendix B of this part.

(4) The maximum demonstrated municipal waste combustor unit load and maximum demonstrated particulate matter control device inlet temperature(s) established during the initial dioxin/furan performance test as recorded under 40 CFR 60.59b(d)(9).

[40 CFR 60.39b and 40 CFR 60.59b(f)]

B.99. Following the first year of municipal combustor operation, the owner or operator of an affected facility shall submit an annual report including the information specified in paragraphs (1) through (4), as applicable, no later than February 1 of each year following the calendar year in which the data were collected (once the unit is subject to permitting requirements under Title V of the Act, the owner or operator of an affected facility must submit these reports semiannually).

(1) A summary of data collected for all pollutants and parameters regulated under this subpart, which includes the information specified in paragraphs (i) through (v).

(i) A list of the particulate matter, opacity, cadmium, lead, mercury, dioxins/furans, hydrogen chloride, and fugitive ash emission levels achieved during the performance tests recorded under 40 CFR 60.59b (d)(9).

(ii) A list of the highest emission level recorded for sulfur dioxide, nitrogen oxides, carbon monoxide, municipal waste combustor unit load level, and particulate matter control device inlet temperature based on the data recorded under 40 CFR 60.59b(d)(2)(ii)(A) through (d)(2)(ii)(D).

(iii) List the highest opacity level measured, based on the data recorded under 40 CFR 60.59b(d)(2)(i)(A).

(iv) The total number of days that the minimum number of hours of data for sulfur dioxide, nitrogen oxides, carbon monoxide, municipal waste combustor unit load, and particulate matter control device temperature data were not obtained based on the data recorded under 40 CFR 60.59b(d)(6).

(v) The total number of hours that data for sulfur dioxide, nitrogen oxides, carbon monoxide, municipal waste combustor unit load, and particulate matter control device temperature were excluded from the calculation of average emission concentrations or parameters based on the data recorded under 40 CFR 60.59b(d)(7).

(2) The summary of data reported under paragraph (1) shall also provide the types of data specified in paragraphs (1)(i) through (1)(vi) for the calendar year preceding the year being reported, in order to provide the Administrator with a summary of the performance of the affected facility over a 2-year period.

(3) The summary of data including the information specified in paragraphs (1) and (2) shall highlight any emission or parameter levels that did not achieve the emission or parameter limits specified under this subpart.

(4) A notification of intent to begin the reduced dioxin/furan performance testing schedule specified in 40 CFR 60.58b(g)(5)(iii) during the following calendar year.

[40 CFR 60.39b and 40 CFR 60.59b(g)]

B.100. The owner or operator of an affected facility shall submit a semiannual report that includes the information specified in paragraphs (1) through (5) for any recorded pollutant or parameter that does not comply with the pollutant or parameter limit specified under this subpart, according to the schedule specified under paragraph (6).

- (1) The semiannual report shall include information recorded under 40 CFR 60.59b(d)(3) for sulfur dioxide, nitrogen oxides, carbon monoxide, municipal waste combustor unit load level, particulate matter control device inlet temperature, and opacity.
- (2) For each date recorded as required by 40 CFR 60.59b(d)(3) and reported as required by paragraph (1), the semiannual report shall include the sulfur dioxide, nitrogen oxides, carbon monoxide, municipal waste combustor unit load level, particulate matter control device inlet temperature, or opacity data, as applicable, recorded under 40 CFR 60.59b(d)(2)(ii)(A) through (d)(2)(ii)(D) and (d)(2)(i)(A), as applicable.
- (3) If the test reports recorded under 40 CFR 56.59b(d)(9) document any particulate matter, opacity, cadmium, lead, mercury, dioxins/furans, hydrogen chloride, and fugitive ash emission levels that were above the applicable pollutant limits, the semiannual report shall include a copy of the test report documenting the emission levels and the corrective actions taken.
- (4) The semiannual report shall include the information recorded under 40 CFR 60.59b(d)(15) for the carbon injection system operating parameter(s) that are the primary indicator(s) of carbon mass feed rate.
- (5) For each operating date reported as required by paragraph (4), the semiannual report shall include the carbon feed rate data recorded under 40 CFR 60.59b(d)(4)(iii).
- (6) Semiannual reports required by this condition shall be submitted according to the schedule specified in paragraphs (i) and (ii).
 - (i) If the data reported in accordance with paragraphs (1) through (5) were collected during the first calendar half, then the report shall be submitted by August 1 following the first calendar half.
 - (ii) If the data reported in accordance with paragraphs (1) through (5) were collected during the second calendar half, then the report shall be submitted by February 1 following the second calendar half.

[40 CFR 60.39b and 40 CFR 60.59b(h)]

B.101. All reports specified under 40 CFR 60.59b(a), (b), (c), (f), (g), (h) and (i) shall be submitted as a paper copy, postmarked on or before the submittal dates specified under these paragraphs, and maintained onsite as a paper copy for a period of 5 years.

[40 CFR 60.39b and 40 CFR 60.59b(j)]

B.102. All records specified under 40 CFR 60.59b(d) and (e) shall be maintained onsite in either paper copy or computer-readable format, unless an alternative format is approved by the Administrator.

[40 CFR 60.39b and 40 CFR 60.59b(k)]

B.103. If the owner or operator of an affected facility would prefer a different annual or semiannual date for submitting the periodic reports required by 40 CFR 60.59b(g), (h) and (i), then the dates may be changed by mutual agreement between the owner or operator and the Administrator according to the procedures specified in 40 CFR 60.19(c) of Subpart A of 40 CFR 60.

[40 CFR 60.39b and 40 CFR 60.59b(l)]

B.104. In the case of excess emissions resulting from malfunctions, each owner or operator shall notify the DEP Southeast District Office in accordance with Rule 62-4.130, F.A.C. A full written report on the malfunctions shall be submitted in a quarterly report, if requested by the DEP Southeast District Office. Rule 62-210.700(6), F.A.C.]

B.105. Submit to the Department a written report of emissions in excess of emission limiting standard for each calendar quarter. The nature and cause of the excess emissions shall be explained. This report does not relieve the owner or operator of the legal liability for violations. All recorded data shall be maintained on file by the Source for a period of five years.

[Rule 62-213.440, F.A.C.]

B.106. CEM Data

(1) Continuous emission monitoring (CEM) systems shall measure stack gas opacity and SO₂, NO_x, CO, and O₂ concentrations for each unit. Continuous monitors for SO₂ shall be installed after the acid gas control device for each unit. The systems shall meet the EPA Monitoring performance specifications of 40 CFR 60.13 and 40 CFR 60, Appendix B, during initial compliance testing and annually thereafter. Additionally CEMs shall meet the quality control requirements of 40 CFR 60, Appendix F.

(2) CEM data recorded during periods of startup, shutdown, and malfunction shall be reported but excluded from compliance averaging periods for CO, NO_x and opacity.

(3) CEM data recorded during periods of startup and shutdown shall be excluded from compliance averaging periods for SO₂.

(4) CEM data recorded during periods of acid gas control device malfunctions shall be excluded from compliance averaging periods for SO₂ provided that the preceding thirty day period which ends on the last day of the malfunction period meets an average SO₂ emission limit equal to the SO₂ limit specified in condition . CEM data must be available for 90% of the operating time for this exemption to apply. A malfunction as used in this permit means any sudden and unavoidable failure of air pollution control equipment or process equipment or of a process to operate in a normal or usual manner. Failures that are caused entirely or in part by poor maintenance, careless operation, or any other preventable upset condition or preventable equipment breakdown shall not be considered malfunctions.

[PSD-FL-112(B)]

B.107. Continuous emissions monitoring data shall be reported to the DEP Southeast District Office and EPA Region 4 on a quarterly basis in accordance with Rule 62-204.800(8), F.A.C. and 40 CFR 60.7 (see specific condition B.92.).

[PSD-FL-112(B)]

B.108. Test Reports.

(a) The owner or operator of an emissions unit for which a compliance test is required shall file a report with the DEP Southeast District Office on the results of each such test.

(b) The required test report shall be filed with the DEP Southeast District Office as soon as practical but no later than 45 days after the last sampling run of each test is completed.

(c) The test report shall provide sufficient detail on the emissions unit tested and the test procedures used to allow the DEP Southeast District Office to determine if the test was properly conducted and the test results properly computed. As a minimum, the test report, other than for an EPA or DEP Method 9 test, shall provide the following information:

1. The type, location, and designation of the emissions unit tested.
2. The facility at which the emissions unit is located.
3. The owner or operator of the emissions unit.
4. The normal type and amount of fuels used and materials processed, and the types and amounts of fuels used and material processed during each test run.
5. The means, raw data and computations used to determine the amount of fuels used and materials processed, if necessary to determine compliance with an applicable emission limiting standard.
6. The type of air pollution control devices installed on the emissions unit, their general condition, their normal operating parameters (pressure drops, total operating current and GPM scrubber water), and their operating parameters during each test run.

7. A sketch of the duct within 8 stack diameters upstream and 2 stack diameters downstream of the sampling ports, including the distance to any upstream and downstream bends or other flow disturbances.
8. The date, starting time and duration of each sampling run.
9. The test procedures used, including any alternative procedures authorized pursuant to Rule 62-297.620, F.A.C. Where optional procedures are authorized in this chapter, indicate which option was used.
10. The number of points sampled and configuration and location of the sampling plane.
11. For each sampling point for each run, the dry gas meter reading, velocity head, pressure drop across the stack, temperatures, average meter temperatures and sample time per point.
12. The type, manufacturer and configuration of the sampling equipment used.
13. Data related to the required calibration of the test equipment.
14. Data on the identification, processing and weights of all filters used.
15. Data on the types and amounts of any chemical solutions used.
16. Data on the amount of pollutant collected from each sampling probe, the filters, and the impingers, are reported separately for the compliance test.
17. The names of individuals who furnished the process variable data, conducted the test, analyzed the samples and prepared the report.
18. All measured and calculated data required to be determined by each applicable test procedure for each run.
19. The detailed calculations for one run that relate the collected data to the calculated emission rate.
20. The applicable emission standard, and the resulting maximum allowable emission rate for the emissions unit, plus the test result in the same form and unit of measure.
21. A certification that, to the knowledge of the owner or his authorized agent, all data submitted are true and correct. When a compliance test is conducted for the Department or its agent, the person who conducts the test shall provide the certification with respect to the test procedures used. The owner or his authorized agent shall certify that all data required and provided to the person conducting the test are true and correct to his knowledge.

[Rule 62-297.310(8), F.A.C.]

B.109. Monthly records shall be maintained of the amount of natural gas and distillate fuel oil used by the auxiliary burners of each MSW unit, the equivalent heat input from natural gas and distillate fuel oil (calculated using the heat value for natural gas/fuel oil provided by the natural gas/fuel oil supplier), and the distillate fuel oil sulfur content (provided by fuel oil supplier). On an annual basis (no later than 30 days after the end of the calendar year), a demonstration must be performed based on the monthly records showing that the capacity factor for natural gas and distillate fuel oil for each unit was 10% or less.

[Rule 62-213.440, F.A.C.]

B.110. Charging Rate Monitoring. The daily solid waste charging rate and hours of operation shall be determined and recorded for each MWC unit. The daily charging rate shall be determined each month on an average daily basis for each MWC unit using the Facility's truck scale weight data, refuse pit inventory and MWC operating data for the preceding calendar month. Monthly truck scale weight records on the weight of solid waste received and processed at the Facility and refuse pit inventory shall be used to determine the amount of solid waste charged during the preceding calendar month on an average daily basis. The MWC load level measurements or other operating data shall be used to determine the number of operating hours per MWC unit for each day during the preceding calendar month.

[40 CFR 60.53(a); and, PSD-FL-112(B)]

B.111. Segregated Solid Waste Record Keeping. The following records shall be made and kept to demonstrate compliance with the segregated non-MSW percentage limitations of specific condition B.16.

(1) Each segregated load of non-MSW materials, that is subject to the percentage weight limitation of specific condition B.16., which is received for processing shall be documented as to waste description and weight. The weight of all waste materials received for processing shall be measured using the facility truck scale and recorded.

(2) Each day the total weight of segregated tires received shall be computed, and the daily total shall be added to the sum of the daily totals from the previous 29 days. The resultant 30 day total weight of tires shall be divided by the total weight of all waste materials received in the same 30 day period, and the resultant number shall be multiplied by 100 to express the ratio in percentage terms. The percentage computed shall be compared to the 3% limitation.

(3) Each day the total weight of segregated non-MSW materials received that are subject to the 5% restriction shall be computed, and the daily total shall be added to the sum of the daily totals from the previous 29 days. The resultant 30 day total weight of segregated non-MSW materials shall be divided by the total weight of all waste materials received in the same 30 day period, and the resultant number shall be multiplied by 100 to express the ratio in percentage terms. The percentage computed shall be compared to the 5% limitation.

[PSD-FL-112(B)]

B.112. Acid Rain Part Application. For any unit which was a solid waste incinerator, burning less than 20 percent fossil fuel as described in 40 CFR 72.6(b)(7), adopted and incorporated by reference at Rule 62-204.800, F.A.C. the designated representative of the source containing the unit shall submit a complete Acid Rain Part application governing such unit to the Department before the later of January 1, 1998, or March 1 of the year following the three calendar year period in which the incinerator consumed 20 percent or more fossil fuel on a British thermal unit (BTU) basis.

[Rule 62-214.320(1)(h), F.A.C.]

Subsection C. This section addresses the following emissions units.

E.U. ID No.	Brief Description:
-004	Material Handling Systems and Treatment Operations 236 Ton Lime Silo with Baghouse
-005	Ash Handling System
-006	Wet Scrubber in Ash Handling Building. (This scrubber has not been installed, but may be installed in the future should facility management deem it necessary for ash building indoor air quality control.)

Emissions unit -004 is a 236 ton capacity silo for storage of pebble lime. It is part of the spray dry absorber (SDA) system used for control of acid gases and sulfur dioxide emissions from the municipal waste combustion units. A supply truck pneumatically transfers pebble lime to the silo through a fill line. A Wheelabrator Air Pollution Control Jet III baghouse (Model No. 1016, BA-108) is used to control particulate matter emissions during silo filling. The baghouse parameters are as follows: stack height = 102 feet; exit dimensions (rectangular vent) = 2.67 x 1 feet; exit temperature = 40-100° F, actual volumetric flow rate = 1,500 acfm. The initial startup date of the silo was April 21, 1991. Emissions unit -005 is the Ash Handling System. It receives fly ash and spray dryer reaction products (calcium sulfate, calcium chloride, calcium hydroxide, calcium fluoride). Particulate matter and visible emissions from the ash handling system are controlled by wet processing in a primarily enclosed building equipped with a planned wet scrubber as described below. The initial startup date of the ash handling system was June 13, 1991.

Emissions unit -006 is a wet scrubber planned for installation in the ash handling building, which contains various pelletizers and conveyors. The wet scrubber is designed to control particulate matter (PM) emissions from the building equipment and thus reduce indoor PM levels and improve indoor air quality for employee comfort and safety. The wet scrubber has an outlet (vent) to the atmosphere. (This scrubber has not been installed, but may be installed in the future should facility management deem it necessary for ash building indoor air quality control.)

Compliance Assurance Monitoring (CAM) Applicability

Specific Condition C.4. contains a particulate matter (PM) emission limit for the lime silo baghouse. The Applicant has provided justification demonstrating that the uncontrolled potential to emit PM is less than 100 tons per year for this emissions unit. Therefore, CAM does not apply.

{Permitting note(s): Emissions units -004 and -005 are minor sources that were permitted under AC06-186997, AC06-186998 (March 12, 1991), 0112120-007-AC (Month, day, year), and AO06-208187 and are regulated under Rule 62-210.300, F.A.C., Permits Required. Emissions unit -005 is also permitted under 0112120-002-AC and 0112120-003-AC and subject to requirements of PSD-FL-112(B) and 40 CFR 60, Subpart Cb. The requirements of 40 CFR 60, Subpart Cb are stated in Subsection B. and referenced in this subsection.}

The following specific conditions apply to the emissions unit(s) listed above:

Essential Potential to Emit (PTE) Parameters

C.1. Permitted Capacity. The lime storage silo filling rate shall not exceed 50,000 lbs/hr of pebble lime. [Rule 62-4.070 (3) F.A.C., and Permit No. 0112120-007-AC (revision of Permit No. AC 06-186998)]

C.2. Emissions Unit Operating Rate Limitation After Testing. See specific condition C.18.
[Rule 62-297.310(2), F.A.C.]

C.3. Hours of Operation. Each unit may operate continuously, i.e., 8,760 hrs/yr.
[Rules 62-213.440 and 62-210.200(PTE), F.A.C.; and Permits AC06 186997, AC06-186998, and 0112120-007-AC]

Emission Limitations and Standards

{Permitting Note: The attached Table 1-1, Summary of Air Pollutant Standards and Terms, summarizes information for convenience purposes only. This table does not supersede any of the terms or conditions of this permit.}

{Permitting note: Unless otherwise specified, the averaging times for Specific Conditions C.4. through C.8. are based on the specified averaging time of the applicable test method.}

C.4. Particulate Matter Emissions. Particulate matter emissions from the lime silo baghouse shall not exceed 0.010 gr./dscf, nor 0.021 tons/year.
[AC06-186997 & AC06-186998]

C.5. Visible Emissions. Visible emissions from lime silo shall not exceed 5% opacity for this minor sources equipped with a baghouse (see specific condition C.15.).
[Rule 62-297.620(4), F.A.C., and AC06-186997 & AC06-186998]

C.6. Ash Handling Emission Points and Ash Processing Equipment. All conveyor loading points, transfer points and all ash processing equipment shall be properly enclosed. The facility shall be operated by personnel properly trained for the equipment herein. The Department shall have been notified in writing on how the facility staff would be staffed and trained.
[AC06-186997 & AC06-186998]

C.7. Fugitive Ash Emissions. See specific condition B.38.
[Rule 62-213.440, F.A.C.]

C.8. Ash Handling Facilities. The potential for dust generation by ash handling activities will be mitigated by quenching or conditioning the ash prior to loading in ash transport trucks. Ash handling facilities shall be primarily enclosed, and the ash handling building may have a wet scrubber installed to control PM emissions. Unprocessed refuse storage areas, which must be open for operational purposes (e.g., tipping floor of the refuse bunker while trucks are entering and leaving), will be under negative air pressure. Residue from the grates, and grate siftings shall be discharged into the bottom ash quenching system, and ash from the combustor/boiler and fabric filter hoppers shall be discharged into the fly ash conditioning system during normal operations to minimize visible dust generation. The ash/residue in the Ash Handling Building shall remain sufficiently moist to minimize dust during storage and handling operations. Compliance with this condition shall be determined in accordance with specific condition B.38.
[PSD-FL-112(B) & PSD-FL-112(C)]

Excess Emissions

C.9. Excess Emissions Allowed. Excess emissions resulting from startup, shutdown or malfunction shall be permitted provided that best operational practices to minimize emissions are adhered to and the duration of excess emissions shall be minimized but in no case exceed two hours in any 24-hour period unless specifically authorized by the Department for longer duration.

[Rule 62-210.700(1), F.A.C.]

C.10. Excess Emissions Prohibited. Excess emissions which are caused entirely or in part by poor maintenance, poor operation, or any other equipment or process failure which may reasonably be prevented during startup, shutdown or malfunction shall be prohibited. [Rule 62-210.700(4), F.A.C.]

Monitoring of Operations

C.11. Determination of Process Variables.

(a) **Required Equipment.** The owner or operator of an emissions unit for which compliance tests are required shall install, operate, and maintain equipment or instruments necessary to determine process variables, such as process weight input or heat input, when such data are needed in conjunction with emissions data to determine the compliance of the emissions unit with applicable emission limiting standards.

(b) **Accuracy of Equipment.** Equipment or instruments used to directly or indirectly determine process variables, including devices such as belt scales, weight hoppers, flow meters, and tank scales, shall be calibrated and adjusted to indicate the true value of the parameter being measured with sufficient accuracy to allow the applicable process variable to be determined within 10% of its true value.

[Rule 62-297.310(5), F.A.C.]

Test Methods and Procedures

{Permitting note: Table 2-1, Summary of Compliance Requirements, summarizes information for convenience purposes only. This table does not supersede any of the terms or conditions of this permit.}

C.12. Annual Tests Required. Annual visible emissions compliance tests shall be performed for each emissions unit.

[Rule 62-297.310(7), F.A.C.]

C.13. Visible Emissions. The test method for visible emissions shall be EPA Method 9, adopted and incorporated in Rule 62-204.800, F.A.C. The visible emissions test for the lime silo shall be conducted for the entire truck unloading operation.

[AC06-186997 & AC06-186998]

C.14. Particulate Matter Emissions. The test method for particulate matter emissions for all units shall be EPA Method 5, adopted and incorporated in Rule 62-204.800, F.A.C.

[AC06-186997 & AC06-186998]

C.15. Particulate Matter Emissions. In the case of an emissions unit which has the potential to emit less than 100 tons per year of particulate matter and is equipped with a baghouse, the Department waives any particulate matter compliance test requirements for such emissions unit specified in any otherwise applicable rule, and specifies an alternative standard of 5% opacity.

If the Department has reason to believe that the particulate weight emission standard applicable to such an emissions unit (see specific condition C.4.) is not being met, it shall require that compliance be demonstrated by the test method specified in the applicable rule (see specific condition C.14.).

[Rule 62-297.620(4), F.A.C.]

C.16. Fugitive Ash. See specific condition B.64.

[Rule 62-213.440, F.A.C.]

C.17. Required Number of Test Runs. For mass emission limitations, a compliance test shall consist of three complete and separate determinations of the total air pollutant emission rate through the test section of the stack or duct and three complete and separate determinations of any applicable process variables corresponding to the three distinct time periods during which the stack emission rate was measured provided, however, that three complete and separate determinations shall not be required if the process variables are not subject to variation during a compliance test, or if three determinations are not necessary in order to calculate the unit's emission rate. The three required test runs shall be completed within one consecutive five day period. In the event that a sample is lost or one of the three runs must be discontinued because of circumstances beyond the control of the owner or operator, and a valid third run cannot be obtained within the five day period allowed for the test, the Secretary or his or her designee may accept the results of the two complete runs as proof of compliance, provided that the arithmetic mean of the results of the two complete runs is at least 20 percent below the allowable emission limiting standards.

[Rule 62-297.310(1), F.A.C.]

C.18. Operating Rate During Testing. Testing of emissions shall be conducted with each emissions unit operation at permitted capacity, which is defined as 90 to 100 percent of the maximum operation rate allowed by the permit. If it is impracticable to test at permitted capacity, an emissions unit may be tested at less than the minimum permitted capacity; in this case, subsequent emissions unit operation is limited to 110 percent of the test load until a new test is conducted. Once the emissions unit is so limited, operation at higher capacities is allowed for no more than 15 consecutive days for the purpose of additional compliance testing to regain the authority to operate at the permitted capacity.

[Rules 62-297.310(2) & (2)(b), F.A.C.]

C.19. Calculation of Emission Rate. The indicated emission rate or concentration shall be the arithmetic average of the emission rate or concentration determined by each of the separate test runs unless otherwise specified in a particular test method or applicable rule.

[Rule 62-297.310(3), F.A.C.]

C.20. Applicable Test Procedures.

(a) **Required Sampling Time.**

1. Unless otherwise specified in the applicable rule, the required sampling time for each test run shall be no less than one hour and no greater than four hours, and the sampling time at each sampling point shall be of equal intervals of at least two minutes.

2. **Opacity Compliance Tests.** When either EPA Method 9 or DEP Method 9 is specified as the applicable opacity test method, the required minimum period of observation for a compliance test shall be sixty (60) minutes for emissions units which emit or have the potential to emit 100 tons per year or more of particulate matter, and thirty (30) minutes for emissions units which have potential emissions less than 100 tons per year of particulate matter and are not subject to a multiple-valued opacity standard. The opacity test observation period shall include the period during which the

highest opacity emissions can reasonably be expected to occur. Exceptions to these requirements are as follows:

- a. For batch, cyclical processes, or other operations which are normally completed within less than the minimum observation period and do not recur within that time, the period of observation shall be equal to the duration of the batch cycle or operation completion time.
- b. The observation period for special opacity tests that are conducted to provide data to establish a surrogate standard pursuant to Rule 62-297.310(5)(k), F.A.C., Waiver of Compliance Test Requirements, shall be established as necessary to properly establish the relationship between a proposed surrogate standard and an existing mass emission limiting standard.
- c. The minimum observation period for opacity tests conducted by employees or agents of the Department to verify the day-to-day continuing compliance of a unit or activity with an applicable opacity standard shall be twelve minutes.

(b) Minimum Sample Volume. Unless otherwise specified in the applicable rule, the minimum sample volume per run shall be 25 dry standard cubic feet.

(c) Required Flow Rate Range. For EPA Method 5 particulate sampling, acid mist/sulfur dioxide, and fluoride sampling which uses Greenburg Smith type impingers, the sampling nozzle and sampling time shall be selected such that the average sampling rate will be between 0.5 and 1.0 actual cubic feet per minute, and the required minimum sampling volume will be obtained.

(d) Calibration of Sampling Equipment. Calibration of the sampling train equipment shall be conducted in accordance with the schedule shown in Table 297.310-1, attached to this permit.

(e) Allowed Modification to EPA Method 5. When EPA Method 5 is required, the following modification is allowed: the heated filter may be separated from the impingers by a flexible tube.
[Rule 62-297.310(4), F.A.C.]

C.21. Required Stack Sampling Facilities. When a mass emissions stack test is required, the permittee shall comply with the requirements contained in Appendix SS-1, Stack Sampling Facilities, attached to this permit.

[Rule 62-297.310(6), F.A.C.]

C.22. Frequency of Compliance Tests. The following provisions apply only to those emissions units that are subject to an emissions limiting standard for which compliance testing is required.

(a) General Compliance Testing.

3. The owner or operator of an emissions unit that is subject to any emission limiting standard shall conduct a compliance test that demonstrates compliance with the applicable emission limiting standard prior to obtaining a renewed operation permit. Emissions units that are required to conduct an annual compliance test may submit the most recent annual compliance test to satisfy the requirements of this provision. In renewing an air operation permit pursuant to Rule 62-210.300(2)(a)3.b., c., or d., F.A.C., the Department shall not require submission of emission compliance test results for any emissions unit that, during the year prior to renewal:

- a. Did not operate; or
- b. In the case of a fuel burning emissions unit, burned liquid and/or solid fuel for a total of no more than 400 hours.

4. During each federal fiscal year (October 1 - September 30), unless otherwise specified by rule, order, or permit, the owner or operator of each emissions unit shall have a formal compliance test conducted for:

- a. Visible emissions, if there is an applicable standard;
- b. Each of the following pollutants, if there is an applicable standard, and if the emissions unit emits or has the potential to emit: 5 tons per year or more of lead or lead compounds measured as

elemental lead; 30 tons per year or more of acrylonitrile; or 100 tons per year or more of any other regulated air pollutant; and

c. Each NESHAP pollutant, if there is an applicable emission standard.

5. An annual compliance test for particulate matter emissions shall not be required for any fuel burning emissions unit that, in a federal fiscal year, does not burn liquid and/or solid fuel, other than during startup, for a total of more than 400 hours.

9. The owner or operator shall notify the DEP Southeast District Office, at least 15 days prior to the date on which each formal compliance test is to begin, of the date, time, and place of each such test, and the test contact person who will be responsible for coordinating and having such test conducted for the owner or operator.

(b) Special Compliance Tests. When the DEP Southeast District Office, after investigation, has good reason (such as complaints, increased visible emissions or questionable maintenance of control equipment) to believe that any applicable emission standard contained in a Department rule or in a permit issued pursuant to those rules is being violated, it may require the owner or operator of the emissions unit to conduct compliance tests which identify the nature and quantity of pollutant emissions from the emissions unit and to provide a report on the results of said tests to the DEP Southeast District Office.

(c) Waiver of Compliance Test Requirements. If the owner or operator of an emissions unit that is subject to a compliance test requirement demonstrates to the Department, pursuant to the procedure established in Rule 62-297.620, F.A.C., that the compliance of the emissions unit with an applicable weight emission limiting standard can be adequately determined by means other than the designated test procedure, such as specifying a surrogate standard of no visible emissions for particulate matter sources equipped with a bag house or specifying a fuel analysis for sulfur dioxide emissions, the Department shall waive the compliance test requirements for such emissions units and order that the alternate means of determining compliance be used, provided, however, the provisions of Rule 62-297.310(7)(b), F.A.C., shall apply.

[Rule 62-297.310(7), F.A.C.; and SIP approved]

Recordkeeping and Reporting

C.23. Fugitive Ash. See specific conditions B.97. - B.100.
[Rule 62-213.440, F.A.C.]

C.24. Excess Emissions from Malfunctions. In the case of excess emissions resulting from malfunctions, each owner or operator shall notify the DEP Southeast District Office in accordance with Rule 62-4.130, F.A.C. A full written report on the malfunctions shall be submitted in a quarterly report, if requested by the DEP Southeast District Office.

[Rule 62-210.700(6), F.A.C.]

C.25. Test Reports.

(a) The owner or operator of an emissions unit for which a compliance test is required shall file a report with the DEP Southeast District Office on the results of each such test.

(b) The required test report shall be filed with the DEP Southeast District Office as soon as practical but no later than 45 days after the last sampling run of each test is completed.

(c) The test report shall provide sufficient detail on the emissions unit tested and the test procedures used to allow the DEP Southeast District Office to determine if the test was properly conducted and the test results properly computed. As a minimum, the test report, other than for an EPA or DEP Method 9 test, shall provide the following information:

1. The type, location, and designation of the emissions unit tested.
2. The facility at which the emissions unit is located.

3. The owner or operator of the emissions unit.
 4. The normal type and amount of fuels used and materials processed, and the types and amounts of fuels used and material processed during each test run.
 5. The means, raw data and computations used to determine the amount of fuels used and materials processed, if necessary to determine compliance with an applicable emission limiting standard.
 6. The type of air pollution control devices installed on the emissions unit, their general condition, their normal operating parameters (pressure drops, total operating current and GPM scrubber water), and their operating parameters during each test run.
 7. A sketch of the duct within 8 stack diameters upstream and 2 stack diameters downstream of the sampling ports, including the distance to any upstream and downstream bends or other flow disturbances.
 8. The date, starting time and duration of each sampling run.
 9. The test procedures used, including any alternative procedures authorized pursuant to Rule 62-297.620, F.A.C. Where optional procedures are authorized in this chapter, indicate which option was used.
 10. The number of points sampled and configuration and location of the sampling plane.
 11. For each sampling point for each run, the dry gas meter reading, velocity head, pressure drop across the stack, temperatures, average meter temperatures and sample time per point.
 12. The type, manufacturer and configuration of the sampling equipment used.
 13. Data related to the required calibration of the test equipment.
 14. Data on the identification, processing and weights of all filters used.
 15. Data on the types and amounts of any chemical solutions used.
 16. Data on the amount of pollutant collected from each sampling probe, the filters, and the impingers, are reported separately for the compliance test.
 17. The names of individuals who furnished the process variable data, conducted the test, analyzed the samples and prepared the report.
 18. All measured and calculated data required to be determined by each applicable test procedure for each run.
 19. The detailed calculations for one run that relate the collected data to the calculated emission rate.
 20. The applicable emission standard, and the resulting maximum allowable emission rate for the emissions unit, plus the test result in the same form and unit of measure.
 21. A certification that, to the knowledge of the owner or his authorized agent, all data submitted are true and correct. When a compliance test is conducted for the Department or its agent, the person who conducts the test shall provide the certification with respect to the test procedures used. The owner or his authorized agent shall certify that all data required and provided to the person conducting the test are true and correct to his knowledge.
- [Rules 62-213.440 and 62-297.310(8), F.A.C.]

Appendix I-1, List of Insignificant Emissions Units and/or Activities.

The facilities, emissions units, or pollutant-emitting activities listed in Rule 62-210.300(3)(a), F.A.C., Categorical Exemptions; or that meet the criteria specified in Rule 62-210.300(3)(b)1., F.A.C., Generic Emissions Unit Exemption, are exempt from the permitting requirements of Chapters 62-210, 62-212 and 62-4, F.A.C.; provided, however, that exempt emissions units shall be subject to any applicable emission limiting standards and the emissions from exempt emissions units or activities shall be considered in determining the potential emissions of the facility containing such emissions units. Emissions units and pollutant-emitting activities exempt from permitting under Rules 62-210.300(3)(a) and (b)1., F.A.C., shall not be exempt from the permitting requirements of Chapter 62-213, F.A.C., if they are contained within a Title V source; however, such emissions units and activities shall be considered insignificant for Title V purposes provided they also meet the criteria of Rule 62-213.430(6)(b), F.A.C. No emissions unit shall be entitled to an exemption from permitting under Rules 62-210.300(3)(a) and (b)1., F.A.C., if its emissions, in combination with the emissions of other units and activities at the facility, would cause the facility to emit or have the potential to emit any pollutant in such amount as to make the facility a Title V source.

The below listed emissions units and/or activities are considered insignificant pursuant to Rule 62-213.430(6), F.A.C.

Brief Description of Emissions Units and/or Activities:

1. Slaker A.
2. Slaker B.
3. 3 Chemical Feed Tanks (for Boiler Nos 1-3).
4. 2 Cooling Tower Bulk Chemical Tanks.
5. Non- Halogenated Solvent Degreaser.
6. Metals Removal System Discharge Chute.
7. Plant Roads.

Appendix H-1, Permit History/ID Number Changes

Wheelabrator North Broward, Inc.
North Broward Waste-to-Energy Facility

Permit No. 0112120-009-AV
Facility ID No. 0112120

Permit History (for tracking purposes):

<u>E.U. ID No.</u>	<u>Description</u>	<u>Permit No.</u>	<u>Issue Date</u>	<u>Expiration Date</u>	<u>Revised Date(s)</u>
001, 002, 003	Municipal Solid Waste Combustors	PSD-FL-112	07/28/87		02/09/89; 05/22/97; 09/28/99.
		PA 86-22	03/09/87		04/12/88; 02/01/89; 10/04/91; 11/30/92
004	Lime Silo	AC06-186998	03/12/91	02/28/92	
		AO06-208187	05/14/92	02/28/96	
		0112120-007-AC			
005	Ash Handling System	AC06-186997	03/12/91	02/28/92	
		AO06-208187	05/14/92	02/28/96	
		0112120-002-AC	10/23/00	10/21/05	
		0112120-003-AC	10/22/02	10/22/02	
All of the above		0112120-001-AV	10/23/00	10/21/05	Initial Title V
		0112120-002-AC	10/23/00	10/21/05	To remove the ash handling system's baghouse
		0112120-003-AC	10/22/02	10/22/02	To allow the scrubber installation in the ash handling facility
		0112120-004-AV	05/15/01	10/21/05	To remove obsolete conditions in the Title V permit
		0112120-005-AV	10/16/02	10/21/05	To allow for 15 hours excess CO emissions
		0112120-006-AV	01/17/03	10/21/05	To allow the scrubber installation in the ash handling facility
		0112120-007-AC	09/28/04	10/21/05	To increase the pebble lime filling rate to 50,000 lb/hr
		0112120-008-AV		10/21/05	To increase the pebble lime filling rate to 50,000 lb/hr

(if applicable) ID Number Changes (for tracking purposes):

From: Facility ID No.: 30BRO062120 To: Facility ID No.: 0112120

Table 1-1, Summary of Air Pollutant Standards and Terms

Wheelabrator North Broward, Inc.
 North Broward Waste-to-Energy Facility

Permit No. 0112120-009-AV
 Facility ID No. 0112120

This table summarizes information for convenience purposes only. This table does not supersede any of the terms or conditions of the permit.

E. U. ID No	Brief Description	Pollutant Name	Fuel(s)	Hours/Year	Allowable Emissions			Equivalent Emissions		Regulatory Citation(s)	See Permit Condition(s)
					Standard(s)	lbs./hour	TPY	lbs./hour	TPY		
-001	UNIT 1 - Municipal Solid Waste (MSW) Combustor (186,000 lbs/hr - steam) (807 TPD - MSW) (302.5 MMBtu/hour-MSW)	VE	MSW	8760	10%			N/A	N/A	40 CFR 60.33b(a)(1)(iii)	B.27.
		VE - Fugitive Ash		8760	5%			N/A	N/A	40 CFR 60.36b	B.38.
		PM ¹	MSW	8760	27 mg/dscm			7.35	32.2	40 CFR 60.33b(a)(1)(i)	B.26.
		PM ₁₀ ¹	MSW	8760	27 mg/dscm			7.35	32.2	40 CFR 60.33b(a)(1)(i)	B.26.
		CO ¹	MSW	8760	100 ppm _{dv}			31.8	139	40 CFR 60.34b(a)	B.37.
		NO _x ¹	MSW	8760	205 ppm _{dv}			107	466	40 CFR 60.33b(d)	B.36.
		SO ₂ ^{1,2}	MSW	8760	29 ppm _{dv} or 75% reduction			33	144	40 CFR 60.33b(b)(3)(i)	B.32.
		HCl ^{1,2}	MSW	8760	29 ppm _{dv} or 95% reduction			12	51	40 CFR 60.33b(b)(3)(ii)	B.34.
		dioxin/furan ¹	MSW	8760	30 ng/dscm (total mass)			8.2E-06	3.6E-05	40 CFR 60.33b(c)(1)(ii)	B.35.
		Cd ¹	MSW	8760	0.040 mg/dscm			0.011	0.048	40 CFR 60.33b(a)(2)(i)	B.28.
		Hg ^{1,2}	MSW	8760	0.070 mg/dscm or 85% reduction			0.019	0.080	Rule 62-296.416(3)(b)1.b., F.A.C.	B.29.
		Pb ¹	MSW	8760	0.44 mg/dscm			0.13	0.58	40 CFR 60.33b(a)(4)	B.31.
		Be ¹	MSW	8760	0.001 mg/dscm			3.00E-04	1.20E-03	PSD-FL-112(B)	B.39.
		Fl	MSW	8760	.0040 lb/mmbtu			1.2	5.3	PSD-FL-112	B.40.
		As	MSW	8760	3.1 x 10 ⁻⁵ lb/mmbtu			9.4E-03	0.041	PA 88-22	B.41.
SAM	MSW	8760	0.047 lb/mmbtu			14.2	62.3	PA 88-22	B.41.		
VOC	MSW	8760	0.013 lb/mmbtu			3.9	17.2	PA 88-22	B.41.		
-002	UNIT 2 - Municipal Solid Waste (MSW) Combustor (186,000 lbs/hr - steam) (807 TPD - MSW) (302.5 MMBtu/hour-MSW)	VE	MSW	8760	10%			N/A	N/A	40 CFR 60.33b(a)(1)(iii)	B.27.
		VE - Fugitive Ash		8760	5%			N/A	N/A	40 CFR 60.36b	B.38.
		PM ¹	MSW	8760	27 mg/dscm			7.35	32.2	40 CFR 60.33b(a)(1)(i)	B.26.
		PM ₁₀ ¹	MSW	8760	27 mg/dscm			7.35	32.2	40 CFR 60.33b(a)(1)(i)	B.26.
		CO ¹	MSW	8760	100 ppm _{dv}			31.8	139	40 CFR 60.34b(a)	B.37.
		NO _x ¹	MSW	8760	205 ppm _{dv}			107	466	40 CFR 60.33b(d)	B.36.
		SO ₂ ^{1,2}	MSW	8760	29 ppm _{dv} or 75% reduction			33	144	40 CFR 60.33b(b)(3)(i)	B.32.
		HCl ^{1,2}	MSW	8760	29 ppm _{dv} or 95% reduction			12	51	40 CFR 60.33b(b)(3)(ii)	B.34.
		dioxin/furan ¹	MSW	8760	30 ng/dscm (total mass)			8.2E-06	3.6E-05	40 CFR 60.33b(c)(1)(ii)	B.35.
		Cd ¹	MSW	8760	0.040 mg/dscm			0.011	0.048	40 CFR 60.33b(a)(2)(i)	B.28.
		Hg ^{1,2}	MSW	8760	0.070 mg/dscm or 85% reduction			0.019	0.080	Rule 62-296.416(3)(b)1.b., F.A.C.	B.29.
		Pb ¹	MSW	8760	0.44 mg/dscm			0.13	0.58	40 CFR 60.33b(a)(4)	B.31.
		Be ¹	MSW	8760	0.001 mg/dscm			3.00E-04	1.20E-03	PSD-FL-112(B)	B.39.
		Fl	MSW	8760	.0040 lb/mmbtu			1.2	5.3	PSD-FL-112	B.40.
		As	MSW	8760	3.1 x 10 ⁻⁵ lb/mmbtu			9.4E-03	0.041	PA 88-22	B.41.
SAM	MSW	8760	0.047 lb/mmbtu			14.2	62.3	PA 88-22	B.41.		
VOC	MSW	8760	0.013 lb/mmbtu			3.9	17.2	PA 88-22	B.41.		

Table 1-1, Summary of Air Pollutant Standards and Tests

Wheelabrator North Broward, Inc.
 North Broward Waste-to-Energy Facility

Permit No. 0112120-009-AV
 Facility ID No. 0112120

This table summarizes information for convenience purposes only. This table does not supersede any of the terms or conditions of the permit.

E. U. ID No	Brief Description	Pollutant Name	Fuel(s)	Hours/Year	Allowable Emissions			Equivalent Emissions		Regulatory Citation(s)	See Permit Condition(s)
					Standard(s)	lbs./hour	TPY	lbs./hour	TPY		
-003	UNIT 3 - Municipal Solid Waste (MSW) Combustor (186,000 lbs/hr - steam) (807 TPD - MSW) (302.5 MMBtu/hour-MSW)	VE	MSW	8760	10%			N/A	N/A	40 CFR 60.33b(a)(1)(iii)	B.27.
		VE - Fugitive Ash		8760	5%			N/A	N/A	40 CFR 60.38b	B.38.
		PM ¹	MSW	8760	27 mg/dscm			7.35	32.2	40 CFR 60.33b(a)(1)(i)	B.26.
		PM ₁₀ ¹	MSW	8760	27 mg/dscm			7.35	32.2	40 CFR 60.33b(a)(1)(i)	B.26.
		CO ¹	MSW	8760	100 ppm _v			31.8	139	40 CFR 60.34b(a)	B.37.
		NO _x ¹	MSW	8760	205 ppm _v			107	466	40 CFR 60.33b(d)	B.36.
		SO ₂ ^{1,2}	MSW	8760	29 ppm _v or 75% reduction			33	144	40 CFR 60.33b(b)(3)(i)	B.32.
		HCl ^{1,2}	MSW	8760	29 ppm _v or 95% reduction			12	51	40 CFR 60.33b(b)(3)(ii)	B.34.
		dioxin/furan ¹	MSW	8760	30 ng/dscm (total mass)			8.2E-06	3.6E-05	40 CFR 60.33b(c)(1)(ii)	B.35.
		Cd ¹	MSW	8760	0.040 mg/dscm			0.011	0.048	40 CFR 60.33b(c)(2)(i)	B.28.
		Hg ^{1,2}	MSW	8760	0.070 mg/dscm or 85% reduction			0.019	0.080	Rule 62-296.416(3)(b)1.b., F.A.C.	B.29.
		Pb ¹	MSW	8760	0.44 mg/dscm			0.13	0.58	40 CFR 60.33b(a)(4)	B.31.
		Be ¹	MSW	8760	0.001 mg/dscm			3.00E-04	1.20E-03	PSD-FL-112(B)	B.39.
		Fl	MSW	8760	.0040 lb/mmbtu			1.2	5.3	PSD-FL-112	B.40.
As	MSW	8760	3.1 x 10 ⁻⁵ lb/mmbtu			9.4E-03	0.041	PA 86-22	B.41.		
SAM	MSW	8760	0.047 lb/mmbtu			14.2	62.3	PA 86-22	B.41.		
VOC	MSW	8760	0.013 lb/mmbtu			3.9	17.2	PA 86-22	B.41.		
-004	Lime Silo	VE		8760	shall not exceed 5%			N/A	N/A	Rule 62-297.620(4), F.A.C.	C.5.
		PM		8760	0.010 gr/dscf		0.021	0.13	AC 188998	C.4.	
-005	Ash Handling System	VE		8760	shall not exceed 5%			N/A	N/A	40 CFR 60.38b	B.38.

Notes:

* The "Equivalent Emissions" listed are for informational purposes.

1. Corrected to 7% O₂

2. Whichever is least stringent.

Table 2-1, Summary of Compliance Requirements

Wheelabrator North Broward, Inc.
 North Broward Waste-to-Energy Facility

Permit No. 0112120-009-AV
 Facility ID No. 0112120

This table summarizes information for convenience purposes only. This table does not supersede any of the terms or conditions of this permit.

E. U. ID No	Brief Description	Pollutant Name or Parameter	Fuel(s)	Compliance Method	Testing Time Frequency	Frequency Base Date	Min. Compliance Test Duration	CMS ¹	See Permit Condition(s)
-001	Municipal Solid Waste (MSW) Combustors (186,000 lbs/hr - steam) (807 TPD - MSW) (302.5 MMBtu/hour - MSW)	VE	MSW	EPA Method 9	Annually		30 minutes	Yes	B.54.
-002		VE- Fugitive Ash		EPA Method 22	Annually		1 hour	No	B.64.
-003		PM							
		PM ₁₀	MSW	EPA Method 5	Annually		1 hour	No	B.54.
		CO	MSW	EPA Method 10, 10A, 10B	Daily		1 hour	Yes	B.21.
		NO _x	MSW	EPA Method 19	Daily		1 hour	Yes	B.62.
		SO ₂	MSW	EPA Method 19	Daily		1 hour	Yes	B.58.
		HCl	MSW	EPA Method 26, 26A	Annually		1 hour	No	B.60.
		dioxin/furan	MSW	EPA Method 23	Annually ²		N/A	No	B.61.
		Cd	MSW	EPA Method 29	Annually		1 hour	No	B.55.
		Hg	MSW	EPA Method 29 or 101A	Quarterly		1 hour	No	B.55.
		Pb	MSW	EPA Method 29 or 12	Annually		1 hour	No	B.55.
		Be	MSW	EPA Method 29	Annually		N/A	No	B.65.
		Fl	MSW	EPA Method 13A, 13B	Every 5 years		1 hour	No	B.66.
		As	MSW	EPA Method 29 or 108	Every 5 years		2 hour	No	B.67.
	SAM	MSW	EPA Method 8	Every 5 years		1 hour	No	B.67.	
	VOC	MSW	EPA Method 18 or 25A	Every 5 years		1 hour	No	B.67.	
-004	Lime Silo	VE		EPA Method 9	Annually		30 minutes	No	C.13.
		PM		EPA Method 5	Every 5 years ³		1 hour	No	C.14.
-005	Ash Handling System	VE		EPA Method 22	Annually		1 hour	No	B.64.

Notes:

- CMS [=] continuous monitoring system used for monitoring requirement in lieu of fuel sampling and analysis if marked 'yes'.
 (Acceptable as long as CMS is maintained and calibrated as required.)
- Test at least one unit annually, subject to 40 CFR 60.38b(b) and 40 CFR 60.58b(g) requirements.
- Particulate matter tests are not required unless visible emissions tests indicate standards have been violated.

ATTACHMENT WNB-EU1-IV3

ALTERNATIVE METHODS OF OPERATION

ATTACHMENT WNB-EU1-IV3

ALTERNATIVE METHODS OF OPERATION

MSW Combustors

Municipal solid waste (MSW) combustors are allowed to burn the following fuels:

- **Municipal Solid Waste.** The primary fuel for this facility is municipal solid waste (MSW), including the items and materials that fit within the definition of MSW.
- **Segregated Load.** The fuel may be received either as a mixture or as a single-item stream (segregated load) of discarded materials. If the facility uses an authorized fuel that is segregated non-MSW material, the fuel will be either:
 - Well mixed with MSW in the refuse pit.
 - Alternately charged with MSW in the hopper.
- **Other Solid Waste.** Subject to the conditions and limitations contained in the permit, the following other solid waste may be used as fuel:
 - Confidential, proprietary or special documents (including but not limited to business records, lottery tickets, event tickets, coupons, credit cards, magnetic tape and microfilm).
 - Contraband that is being destroyed at the request of appropriately authorized local, state, or federal governmental agencies, provided that such material is not an explosive, a propellant, a hazardous waste, or otherwise prohibited at the facility. For the purposes of this section, contraband includes but is not limited to drugs, narcotics, fruits, vegetables, plants, counterfeit money, and counterfeit consumer goods.
 - Wood pallets, clean wood, and land clearing debris.
 - Packaging materials and containers.
 - Clothing, natural and synthetic fibers, fabric remnants, and similar debris, including but not limited to aprons and gloves.
 - Rugs, carpets, and floor coverings but not asbestos-containing materials or polyethylene or polyurethane vinyl floor coverings.
 - The predominantly combustible fraction of sorted construction and demolition debris. Sorting of mixed construction and demolition debris at the facility shall occur on the tipping floor or at another location approved by the Department.
- **Waste Tires.** Waste tires may be used as fuel at the facility. The total quantity of waste tires received as segregated loads and burned at the facility must not exceed 3 percent, by weight, of the facility's total fuel.
- **Other Solid Waste/Segregated Loads.** Solid waste materials may be used as fuel at the facility (i.e., the following are authorized fuels that are non-MSW material). The total quantity of the following non-MSW material received as segregated loads and burned at the facility shall not exceed 5 percent, by weight, of the facility's total fuel.
 - Construction and demolition debris.
 - Oil spill debris from aquatic, coastal, estuarine or river environments. Such items or materials include but are not limited to rags, wipes, and absorbents.
 - Items suitable for human, plant, or domesticated animal use, consumption or application where the item's shelf-life has expired or the generator wishes to remove the items from the market. Such items or materials include but are not limited to off-specification or expired consumer products, pharmaceuticals, medications, health and

personal care products, cosmetics, foodstuffs, nutritional supplements, returned goods, and controlled substances.

- Consumer-packaged products intended for human or domesticated animal use or application but not consumption. Such items or materials include but are not limited to carpet cleaners, household or bathroom cleaners, polishes, waxes, and detergents.
- Waste materials that:
 - Are generated in the manufacture of items in categories (c) or (d), above and are functionally or commercially useless (expired, rejected or spent).
 - Are not yet formed or packaged for commercial distribution. Such items or materials must be substantially similar to other items or materials routinely found in MSW.
- Waste materials that contain oil from:
 - The routine cleanup of industrial or commercial establishments and machinery.
 - Spills of virgin or used petroleum products. Such items or materials include but are not limited to rags, wipes, and absorbents.
- Used oil and used oil filters. Used oil containing a PCB concentration equal or greater than 50 parts per million (ppm) shall not be burned.
- Waste materials generated by manufacturing, industrial or agricultural activities, provided that these items or materials are substantially similar to items or materials that are found routinely in MSW, subject to prior approval of the Department.

Auxiliary Burners Fuels

Only distillate fuel oil or natural gas shall be used in the startup burners. Natural gas may be used as fuel during warm-up, startup, shutdown, and malfunction periods, and at other times when necessary and consistent with good combustion practices. The facility has a 0.10 capacity factor limitation on the use of natural gas and distillate fuel oil. Sulfur content of the auxiliary burner fuels is limited to 0.3 percent, by weight (not federally enforceable).

EMISSIONS UNIT INFORMATION

Section [2]

236 Ton Lime Silo with a Baghouse

III. EMISSIONS UNIT INFORMATION

Title V Air Operation Permit Application - For Title V air operation permitting only, emissions units are classified as regulated, unregulated, or insignificant. If this is an application for an initial, revised or renewal Title V air operation permit, a separate Emissions Unit Information Section (including subsections A through I as required) must be completed for each regulated and unregulated emissions unit addressed in this application. Some of the subsections comprising the Emissions Unit Information Section of the form are optional for unregulated emissions units. Each such subsection is appropriately marked. Insignificant emissions units are required to be listed at Section II, Subsection C.

Air Construction Permit or FESOP Application - For air construction permitting or federally enforceable state air operation permitting, emissions units are classified as either subject to air permitting or exempt from air permitting. The concept of an "unregulated emissions unit" does not apply. If this is an application for an air construction permit or FESOP, a separate Emissions Unit Information Section (including subsections A through I as required) must be completed for each emissions unit subject to air permitting addressed in this application for air permit. Emissions units exempt from air permitting are required to be listed at Section II, Subsection C.

Air Construction Permit and Revised/Renewal Title V Air Operation Permit Application - Where this application is used to apply for both an air construction permit and a revised or renewal Title V air operation permit, each emissions unit is classified as either subject to air permitting or exempt from air permitting for air construction permitting purposes, and as regulated, unregulated, or insignificant for Title V air operation permitting purposes. A separate Emissions Unit Information Section (including subsections A through I as required) must be completed for each emissions unit addressed in this application that is subject to air construction permitting and for each such emissions unit that is a regulated or unregulated unit for purposes of Title V permitting. (An emissions unit may be exempt from air construction permitting but still be classified as an unregulated unit for Title V purposes.) Emissions units classified as insignificant for Title V purposes are required to be listed at Section II, Subsection C.

If submitting the application form in hard copy, the number of this Emissions Unit Information Section and the total number of Emissions Unit Information Sections submitted as part of this application must be indicated in the space provided at the top of each page.

EMISSIONS UNIT INFORMATION

Section [2]

236 Ton Lime Silo with a Baghouse

A. GENERAL EMISSIONS UNIT INFORMATION

Title V Air Operation Permit Emissions Unit Classification

1. Regulated or Unregulated Emissions Unit? (Check one, if applying for an initial, revised or renewal Title V air operation permit. Skip this item if applying for an air construction permit or FESOP only.)
- The emissions unit addressed in this Emissions Unit Information Section is a regulated emissions unit.
- The emissions unit addressed in this Emissions Unit Information Section is an unregulated emissions unit.

Emissions Unit Description and Status

1. Type of Emissions Unit Addressed in this Section: (Check one)
- This Emissions Unit Information Section addresses, as a single emissions unit, a single process or production unit, or activity, which produces one or more air pollutants and which has at least one definable emission point (stack or vent).
- This Emissions Unit Information Section addresses, as a single emissions unit, a group of process or production units and activities which has at least one definable emission point (stack or vent) but may also produce fugitive emissions.
- This Emissions Unit Information Section addresses, as a single emissions unit, one or more process or production units and activities which produce fugitive emissions only.

2. Description of Emissions Unit Addressed in this Section:
236-Ton Lime Silo with Baghouse

3. Emissions Unit Identification Number: **004**

4. Emissions Unit Status Code: A	5. Commence Construction Date:	6. Initial Startup Date: 4/21/1991	7. Emissions Unit Major Group SIC Code: 49
--	--------------------------------	--	--

8. Federal Program Applicability: (Check all that apply)
- Acid Rain Unit
- CAIR Unit

9. Package Unit:
 Manufacturer: _____ Model Number: _____

10. Generator Nameplate Rating: **MW**

11. Emissions Unit Comment:
EU 004 is a 236 ton capacity silo for storage of pebble lime. It is part of the Spray Dryer Absorber (SDA) system used for control of acid gases and SO₂ emissions from the MWC units. A supply truck pneumatically transfers pebble lime to the silo through a fill line. A Wheelabrator Air Pollution Control Jet III baghouse (Model No. 1016, BA-108) is used to control PM emissions during silo filling.

EMISSIONS UNIT INFORMATION

Section [2]

236 Ton Lime Silo with a Baghouse

Emissions Unit Control Equipment/Method: Control 1 of 1

1. Control Equipment/Method Description: Fabric Filter - Low Temperature [T < 180 degrees Fahrenheit (°F)]
2. Control Device or Method Code: 18

Emissions Unit Control Equipment/Method: Control ____ of ____

1. Control Equipment/Method Description:
2. Control Device or Method Code:

Emissions Unit Control Equipment/Method: Control ____ of ____

1. Control Equipment/Method Description:
2. Control Device or Method Code:

Emissions Unit Control Equipment/Method: Control ____ of ____

1. Control Equipment/Method Description:
2. Control Device or Method Code:

EMISSIONS UNIT INFORMATION

Section [2]

236 Ton Lime Silo with a Baghouse

B. EMISSIONS UNIT CAPACITY INFORMATION

(Optional for unregulated emissions units.)

Emissions Unit Operating Capacity and Schedule

1. Maximum Process or Throughput Rate:	50,000 lb/hr Pebble Lime	
2. Maximum Production Rate:		
3. Maximum Heat Input Rate:	million Btu/hr	
4. Maximum Incineration Rate:	pounds/hr tons/day	
5. Requested Maximum Operating Schedule:	24 hours/day 52 weeks/year	7 days/week 8,760 hours/year
6. Operating Capacity/Schedule Comment:		

EMISSIONS UNIT INFORMATION

Section [2]

236 Ton Lime Silo with a Baghouse

C. EMISSION POINT (STACK/VENT) INFORMATION**(Optional for unregulated emissions units.)****Emission Point Description and Type**

1. Identification of Point on Plot Plan or Flow Diagram: LIME SILO		2. Emission Point Type Code:	
3. Descriptions of Emission Points Comprising this Emissions Unit for VE Tracking:			
4. ID Numbers or Descriptions of Emission Units with this Emission Point in Common:			
5. Discharge Type Code:	6. Stack Height: 102 feet	7. Exit Diameter: 2.67 feet	
8. Exit Temperature: 100°F	9. Actual Volumetric Flow Rate: 1,500 acfm	10. Water Vapor: %	
11. Maximum Dry Standard Flow Rate: dscfm		12. Nonstack Emission Point Height: feet	
13. Emission Point UTM Coordinates... Zone: 17 East (km): 583.891 North (km): 2907.777		14. Emission Point Latitude/Longitude... Latitude (DD/MM/SS) 26/17/14 Longitude (DD/MM/SS) 80/09/35	
15. Emission Point Comment: Rectangular exit vent dimension 2.67 x 1 feet.			

EMISSIONS UNIT INFORMATION

Section [2]

236 Ton Lime Silo with a Baghouse

D. SEGMENT (PROCESS/FUEL) INFORMATION

Segment Description and Rate: Segment 1 of 1

1. Segment Description (Process/Fuel Type): Industrial Processes; Mineral Products; Bulk Materials Loading Operation: Mineral		
2. Source Classification Code (SCC): 3-01-830-01		3. SCC Units: Tons Material Processed
4. Maximum Hourly Rate: 25	5. Maximum Annual Rate: 219,000	6. Estimated Annual Activity Factor:
7. Maximum % Sulfur:	8. Maximum % Ash:	9. Million Btu per SCC Unit:
10. Segment Comment: Pebble Lime Storage Silo		

Segment Description and Rate: Segment ____ of ____

1. Segment Description (Process/Fuel Type):		
2. Source Classification Code (SCC):		3. SCC Units:
4. Maximum Hourly Rate:	5. Maximum Annual Rate:	6. Estimated Annual Activity Factor:
7. Maximum % Sulfur:	8. Maximum % Ash:	9. Million Btu per SCC Unit:
10. Segment Comment:		

EMISSIONS UNIT INFORMATION

Section [2]

236 Ton Lime Silo with a Baghouse

E. EMISSIONS UNIT POLLUTANTS

List of Pollutants Emitted by Emissions Unit

1. Pollutant Emitted	2. Primary Control Device Code	3. Secondary Control Device Code	4. Pollutant Regulatory Code
PM	18		EL

EMISSIONS UNIT INFORMATION

Section [2]
236 Ton Lime Silo with a Baghouse

POLLUTANT DETAIL INFORMATION

Page [1] of [1]
Particulate Matter Total - PM

**F1. EMISSIONS UNIT POLLUTANT DETAIL INFORMATION –
POTENTIAL, FUGITIVE, AND ACTUAL EMISSIONS**

(Optional for unregulated emissions units.)

Complete a Subsection F1 for each pollutant identified in Subsection E if applying for an air construction permit or concurrent processing of an air construction permit and a revised or renewal Title V operation permit. Complete for each emissions-limited pollutant identified in Subsection E if applying for an air operation permit.

Potential, Estimated Fugitive, and Baseline & Projected Actual Emissions

1. Pollutant Emitted: PM		2. Total Percent Efficiency of Control: 99	
3. Potential Emissions: 0.13 lb/hour 0.021 tons/year		4. Synthetically Limited? <input checked="" type="checkbox"/> Yes <input type="checkbox"/> No	
5. Range of Estimated Fugitive Emissions (as applicable): to tons/year			
6. Emission Factor: 0.01 gr/dscf Reference: Permit No. 0112120-009-AV			7. Emissions Method Code: 0
8.a. Baseline Actual Emissions (if required): tons/year		8.b. Baseline 24-month Period: From: To:	
9.a. Projected Actual Emissions (if required): tons/year		9.b. Projected Monitoring Period: <input type="checkbox"/> 5 years <input type="checkbox"/> 10 years	
10. Calculation of Emissions: Hourly emission = 0.01 gr/dscf x 1,500 acfm x 1 lb/7,000 gr x 60 min/hr = 0.13 lb/hr			
11. Potential, Fugitive, and Actual Emissions Comment: Annual emissions limited to 0.021 tons/yr.			

EMISSIONS UNIT INFORMATION

POLLUTANT DETAIL INFORMATION

Section [2]

Page [1] of [1]

236 Ton Lime Silo with a Baghouse

Particulate Matter Total - PM

**F2. EMISSIONS UNIT POLLUTANT DETAIL INFORMATION -
ALLOWABLE EMISSIONS**

Complete Subsection F2 if the pollutant identified in Subsection F1 is or would be subject to a numerical emissions limitation.

Allowable Emissions Allowable Emissions 1 of 2

1. Basis for Allowable Emissions Code: OTHER	2. Future Effective Date of Allowable Emissions:
3. Allowable Emissions and Units: 0.01 gr/dscf	4. Equivalent Allowable Emissions: 0.13 lb/hour tons/year
5. Method of Compliance: EPA Method 5. Test not required unless VE standard is violated.	
6. Allowable Emissions Comment (Description of Operating Method): AC06-186997 and AC06-186998	

Allowable Emissions Allowable Emissions 2 of 2

1. Basis for Allowable Emissions Code: OTHER	2. Future Effective Date of Allowable Emissions:
3. Allowable Emissions and Units: 0.021 tons/yr	4. Equivalent Allowable Emissions: lb/hour 0.021 tons/year
5. Method of Compliance: EPA Method 5. Test not required unless VE standard is violated.	
6. Allowable Emissions Comment (Description of Operating Method): AC06-186997 and AC06-186998	

Allowable Emissions Allowable Emissions ____ of ____

1. Basis for Allowable Emissions Code:	2. Future Effective Date of Allowable Emissions:
3. Allowable Emissions and Units:	4. Equivalent Allowable Emissions: lb/hour tons/year
5. Method of Compliance:	
6. Allowable Emissions Comment (Description of Operating Method):	

EMISSIONS UNIT INFORMATION

Section [2]

236 Ton Lime Silo with a Baghouse

G. VISIBLE EMISSIONS INFORMATION

Complete Subsection G if this emissions unit is or would be subject to a unit-specific visible emissions limitation.

Visible Emissions Limitation: Visible Emissions Limitation 1 of 1

1. Visible Emissions Subtype: VE05	2. Basis for Allowable Opacity: <input checked="" type="checkbox"/> Rule <input type="checkbox"/> Other
3. Allowable Opacity: Normal Conditions: 5 % Exceptional Conditions: % Maximum Period of Excess Opacity Allowed: min/hour	
4. Method of Compliance: EPA Method 9, Annually	
5. Visible Emissions Comment: Rule 62-297.620(4)	

Visible Emissions Limitation: Visible Emissions Limitation ____ of ____

1. Visible Emissions Subtype:	2. Basis for Allowable Opacity: <input type="checkbox"/> Rule <input type="checkbox"/> Other
3. Allowable Opacity: Normal Conditions: % Exceptional Conditions: % Maximum Period of Excess Opacity Allowed: min/hour	
4. Method of Compliance:	
5. Visible Emissions Comment:	

EMISSIONS UNIT INFORMATION

Section [2]

236 Ton Lime Silo with a Baghouse

H. CONTINUOUS MONITOR INFORMATION

Complete Subsection H if this emissions unit is or would be subject to continuous monitoring.

Continuous Monitoring System: Continuous Monitor ____ of ____

1. Parameter Code:	2. Pollutant(s):
3. CMS Requirement:	<input type="checkbox"/> Rule <input type="checkbox"/> Other
4. Monitor Information... Manufacturer: Model Number:	Serial Number:
5. Installation Date:	6. Performance Specification Test Date:
7. Continuous Monitor Comment:	

Continuous Monitoring System: Continuous Monitor ____ of ____

1. Parameter Code:	2. Pollutant(s):
3. CMS Requirement:	<input type="checkbox"/> Rule <input type="checkbox"/> Other
4. Monitor Information... Manufacturer: Model Number:	Serial Number:
5. Installation Date:	6. Performance Specification Test Date:
7. Continuous Monitor Comment:	

EMISSIONS UNIT INFORMATION

Section [2]

236 Ton Lime Silo with a Baghouse

I. EMISSIONS UNIT ADDITIONAL INFORMATION

Additional Requirements for All Applications, Except as Otherwise Stated

1. Process Flow Diagram: (Required for all permit applications, except Title V air operation permit revision applications if this information was submitted to the department within the previous five years and would not be altered as a result of the revision being sought) <input checked="" type="checkbox"/> Attached, Document ID: WNB-EU2-11 <input type="checkbox"/> Previously Submitted, Date _____
2. Fuel Analysis or Specification: (Required for all permit applications, except Title V air operation permit revision applications if this information was submitted to the department within the previous five years and would not be altered as a result of the revision being sought) <input type="checkbox"/> Attached, Document ID: _____ <input type="checkbox"/> Previously Submitted, Date _____
3. Detailed Description of Control Equipment: (Required for all permit applications, except Title V air operation permit revision applications if this information was submitted to the department within the previous five years and would not be altered as a result of the revision being sought) <input checked="" type="checkbox"/> Attached, Document ID: WNB-EU2-13 <input type="checkbox"/> Previously Submitted, Date _____
4. Procedures for Startup and Shutdown: (Required for all operation permit applications, except Title V air operation permit revision applications if this information was submitted to the department within the previous five years and would not be altered as a result of the revision being sought) <input type="checkbox"/> Attached, Document ID: _____ <input type="checkbox"/> Previously Submitted, Date _____ <input type="checkbox"/> Not Applicable (construction application)
5. Operation and Maintenance Plan: (Required for all permit applications, except Title V air operation permit revision applications if this information was submitted to the department within the previous five years and would not be altered as a result of the revision being sought) <input type="checkbox"/> Attached, Document ID: _____ <input type="checkbox"/> Previously Submitted, Date _____ <input checked="" type="checkbox"/> Not Applicable
6. Compliance Demonstration Reports/Records: <input type="checkbox"/> Attached, Document ID: _____ Test Date(s)/Pollutant(s) Tested: _____ <input type="checkbox"/> Previously Submitted, Date: _____ Test Date(s)/Pollutant(s) Tested: _____ <input type="checkbox"/> To be Submitted, Date (if known): _____ Test Date(s)/Pollutant(s) Tested: _____ <input type="checkbox"/> Not Applicable Note: For FESOP applications, all required compliance demonstration records/reports must be submitted at the time of application. For Title V air operation permit applications, all required compliance demonstration reports/records must be submitted at the time of application, or a compliance plan must be submitted at the time of application.
7. Other Information Required by Rule or Statute: <input type="checkbox"/> Attached, Document ID: _____ <input checked="" type="checkbox"/> Not Applicable

ATTACHMENT WNB-EU2-11
PROCESS FLOW DIAGRAM

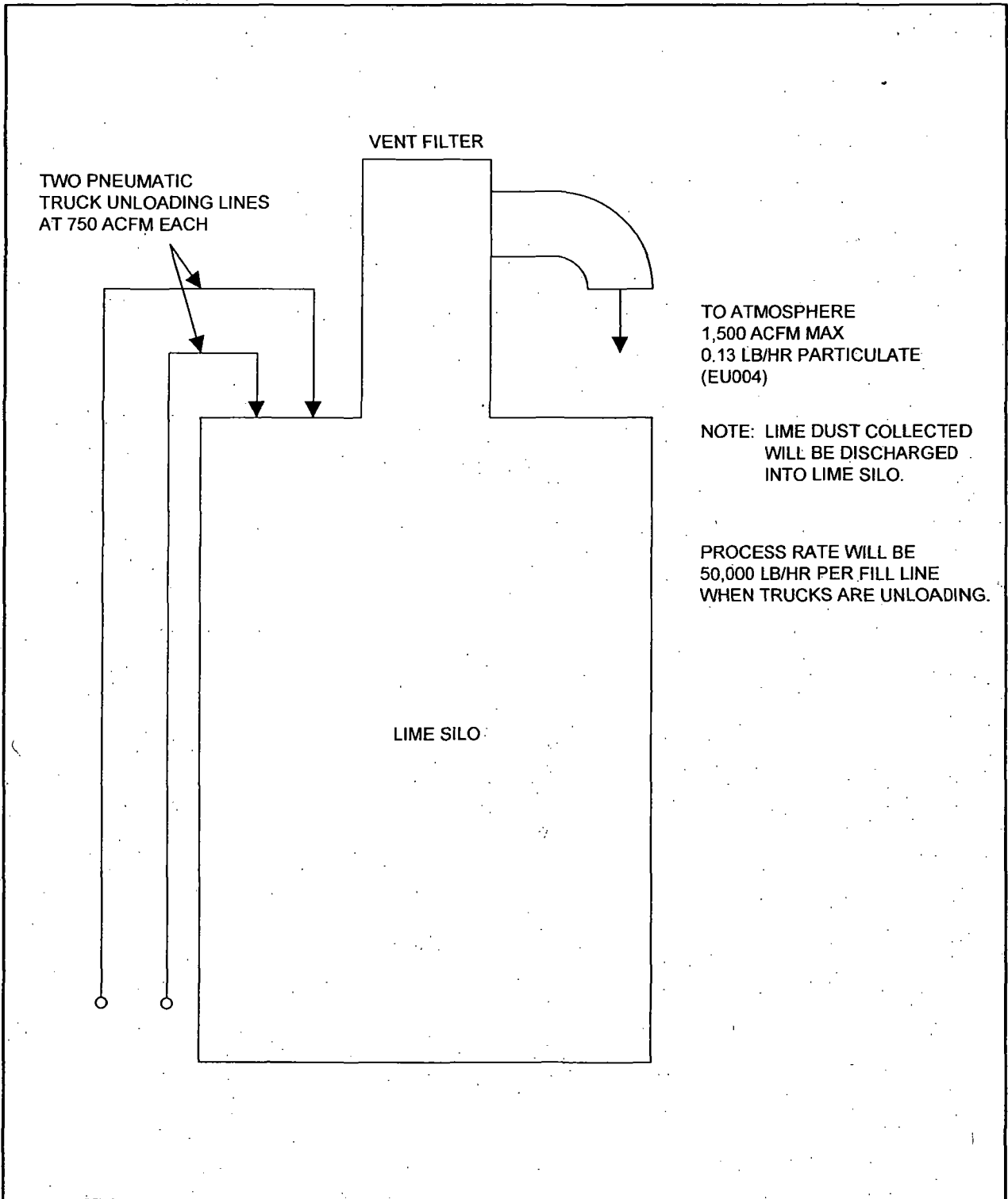

Attachment WNB-EU2-11
Lime Silo Dust Control Flow Diagram
Wheelabrator North Broward, Pompano Beach, Florida

Filename:

WNB-EU2-11.vsd

Date:

06/23/10



ATTACHMENT WNB-EU2-I3

DETAILED DESCRIPTION OF CONTROL EQUIPMENT

JET III™

THE NEW GENERATION OF DUST COLLECTORS

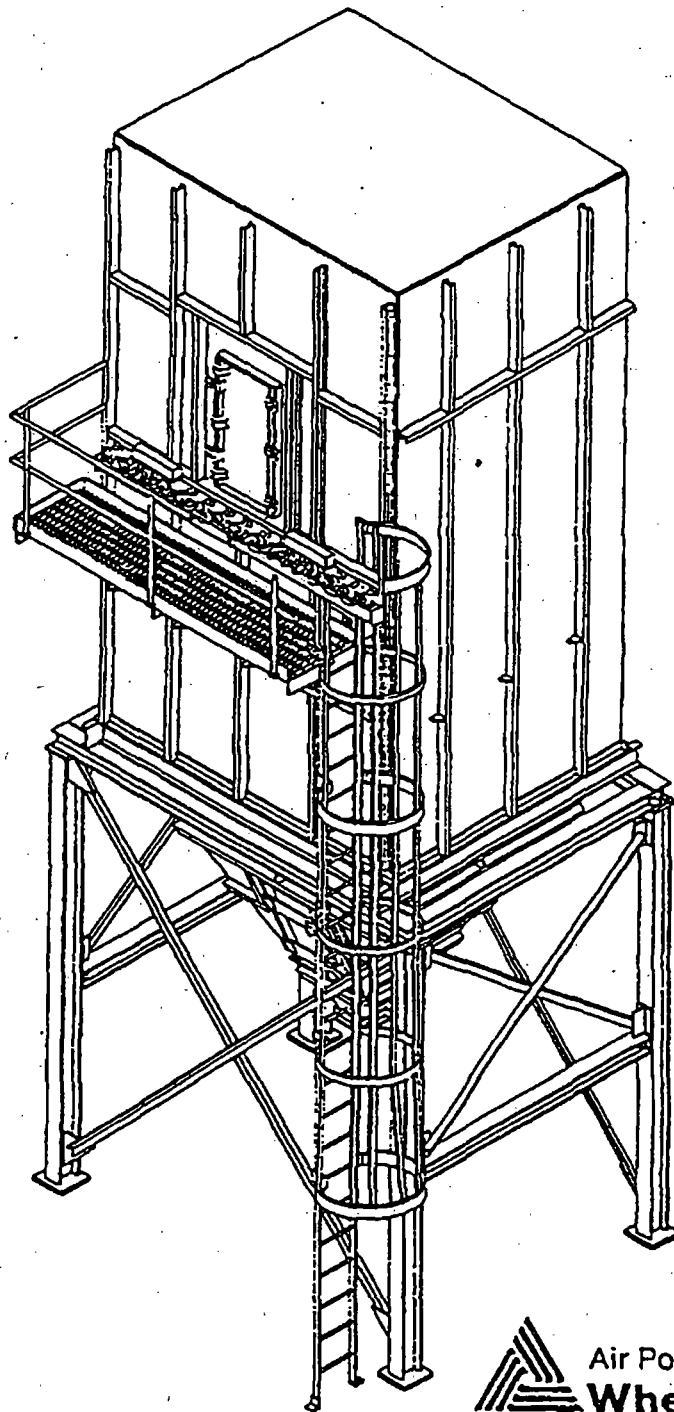

 Air Pollution Control Division
Wheelabrator-Frye Inc

JET III

The new generation of dust collectors

Someday, all dust collectors may offer the benefits of JET III:

- High collection efficiencies
- Low first cost
- Low maintenance cost
- Low operating cost

Why wait for someday?

JET III is a wholly-new design in pulse-jet dust collectors, offering the high collection efficiencies required by increasingly stringent environmental regulations, plus true economy for the plant owner. Economy is achieved by a new, state-of-the-art system designed to reduce maintenance, labor, parts and energy costs.

Available in a full range of standard cloth areas, JET III also offers flexible sizing and efficient, space-saving installa-

tion. Variation of the tube sheet/bag length can be tailored to a particular application and dust condition. This flexibility enables a relatively small-sized housing to be employed on large-volume jobs, lowering capital costs. Smaller modules (1,140 to 5,570 ft² of cloth area) are square in plan, and large-volume modules (4,910 to 12,800 ft² of cloth area) are rectangular. Both designs feature specially-designed inlet connections for efficient gas flow and long filter bag life.

Access to the unit is provided by an integral, full-height, weather-proof, walk-in, clean air plenum. Where heat or other factors present special problems, or where bags in excess of 144

inches long are used, manually operated, hinged roof doors are available.

JET III housings are constructed of 10-gauge hot rolled sheet steel stiffened for 20" WG. All JET III units are completely fabricated before shipment for easy, economical field erection. Square modules are shipped as assembled, one-piece units, complete with flanged inlet and outlet connections. Due to restrictions in certain geographic areas, the air header and valve assemblies may be shipped as a sub-assembly for field installations. The large-volume modules are shipped in three, pre-matched sections for easy job-site completion.

3 important ways better

While sizing, access and housing construction of a dust collector are important, the critical features are the internals. Inside, JET III shows its superiority in

these exclusive areas:

1. Tube sheet and bag attachment
2. Venturi and cage
3. Pulse cleaning system

The following pages describe these exclusive features of JET III that yield real benefits in operation and economy for you.

JET III - 3 important ways better

#1 - Tube Sheet & Bag Attachment

- Die-formed cups for added strength
- Positive seal against dust leakage
- Fast bag attachment, without tools
- Simple, one-step bagging
- Improves clean-side work area

Tube Sheet:

JET III uses the Wheelabrator-Frye drawn-cup tube sheet, previously available only in higher-priced collectors. The bag cups are drawn, eliminating welds which could fail or leak. The tube sheet is seal-welded into the housing to effect a positive seal against dust

penetration. Also, the tube sheet's flat, smooth upper surface simplifies maintenance and housekeeping.

Bag Attachment:

JET III tube sheet features patented Wheelabrator-Frye "snap-ring" bag sealing.

Unlike other designs where bag installation often is a two-man, two-step operation external to the filter, JET III offers a fast, one-man, one-step process. Our tube sheet, acting as a natural bagging fixture, allows cage insertion directly into the tube sheet and bags.

This simple, one-step attach-

ment creates the only seal necessary, eliminating the need for secondary seals such as "O" rings or gaskets. In fact, it would be difficult to install a bag which did not seal properly. On major change-outs, bags can be dropped to the dirty side hopper below, to maintain a true, clean-side work environment.

JET III filter bags are supplied by Wheelabrator-Frye's own W.W. Criswell Division. A complete range of high-quality bags is available in all popular synthetic fibers, including high-temperature fabrics.

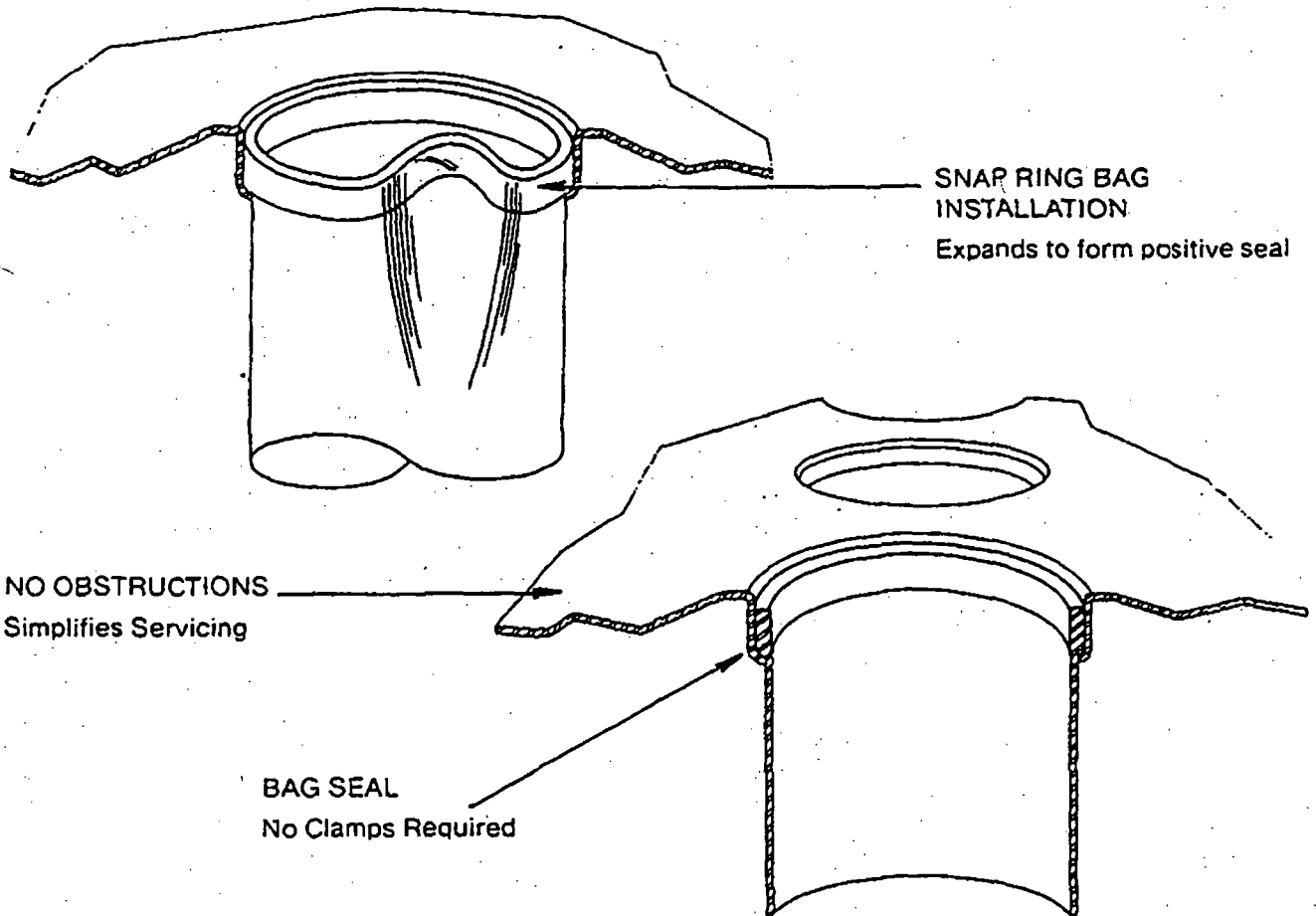

JET III - 3 important ways better

#2 - Venturi and Cage

- Designed to save compressed air costs
- Venturi self-aligns for easy installation and efficient pulse cleaning
- Simple interlock for rapid assembly
- Quality bag support cages

The high-gain throat of JET III's newly-designed venturi is capable of cleaning more surface area of filter media with less compressed air. This provides effective cleaning of JET III's 6" diameter bags up to 14' long while the collector is on stream. JET III's venturi

may be supplied in aluminum or cast iron. The venturi is self-aligning in the bag support cage and tube sheet for easy installation and maximum cleaning efficiency. No fittings, clamps, gaskets or attachments are required to secure the assembly.

JET III features the industry's simplest yet most effective venturi and cage assembly. Assembly requires only a single snap interlock of the venturi within the cage. The weight of the cage is then supported by the venturi flange.

The standard bag support

cage is made of heavy-gauge wire to provide maximum support for long filter bag life. This rugged construction maintains alignment and critical dimensional relationship between bag and cage.

Cages are specifically designed to withstand rough handling during installation and subsequent bag change-outs. Carbon steel is standard. Stainless steel cages and corrosion-resistant coatings are available for special applications.

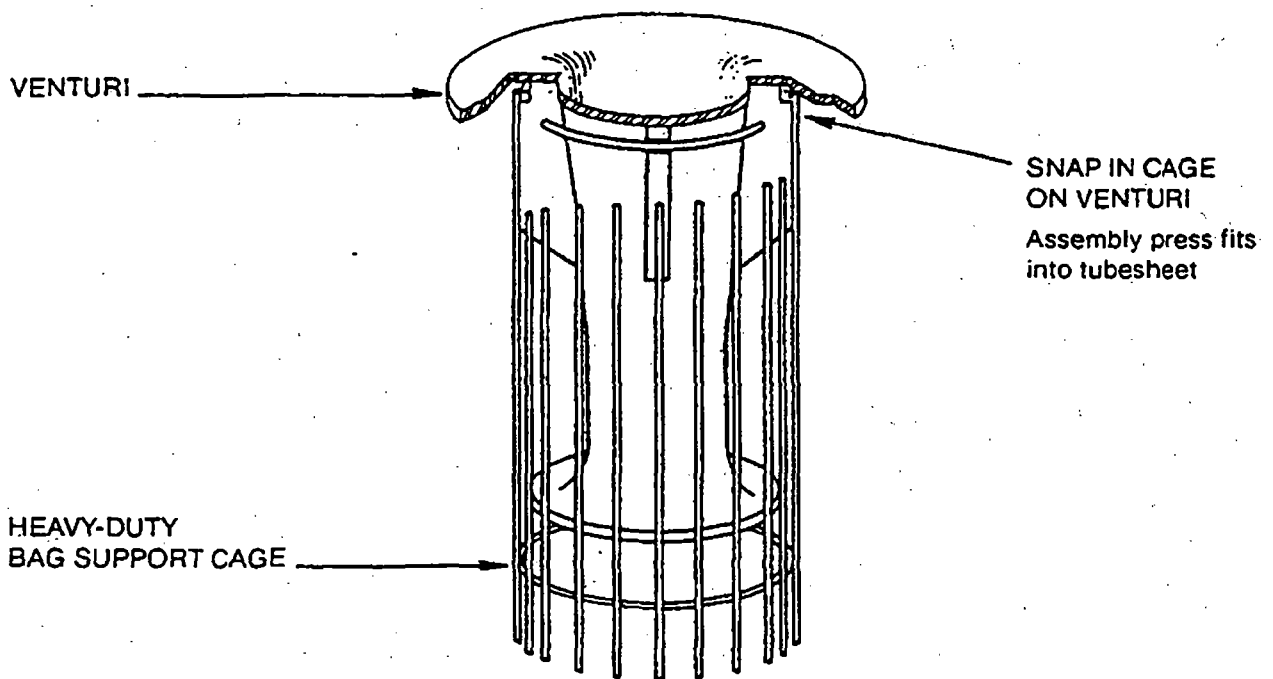

JET III—3 important ways better

#3—Pulse Cleaning System

- Simple design uses few parts
- Easy to maintain
- Saves energy costs

JET III features a uniquely designed pulse-jet cleaning system. Resulting from extensive research, JET III's pulse cleaning hardware is designed to clean with minimum air consumption and maximum energy savings. More filter cloth area is cleaned per horsepower than in previous designs. Field tested on critical industry applications, the JET III cleaning system can also contribute to prolonging filter bag life. JET III's header, air valves and manifold combine to offer a highly effective cleaning system.

1. JET III Header

The compressed air header is square in section for space saving, positive alignment and convenient bolt-on

of air valves. This eliminates leakage common to other designs.

The header assemblies are sectioned to permit local isolation for maintenance without shutting down the total system. These sectioned headers provide rapid depletion of the header pressure. The system requires a maximum line pressure of 90 PSI for energy conservation.

2. JET III Double-Diaphragm Air Valve

Special Wheelabrator-Frye double-diaphragm valves are fitted to square headers. This air dump valve, matched to the new venturi, provides the air for cleaning up to 15 bags per row. Fewer valves per square

foot of cloth mean less maintenance and fewer parts in inventory. The valve also allows the convenience of remote pilot control (for low-cost electrical installation) with no loss of efficiency across the air valve. The air valve is simple to replace should this ever become necessary.

3. JET III Manifold

The 1½"-diameter manifold pipe is jig-drilled for positive alignment of the blow holes with the venturi centers to assure maximum efficiency. Fit of the manifold within the plenum is positive to maintain this alignment. For bag inspection and/or removal, the manifold can be removed with a minimum of effort and no special tools.

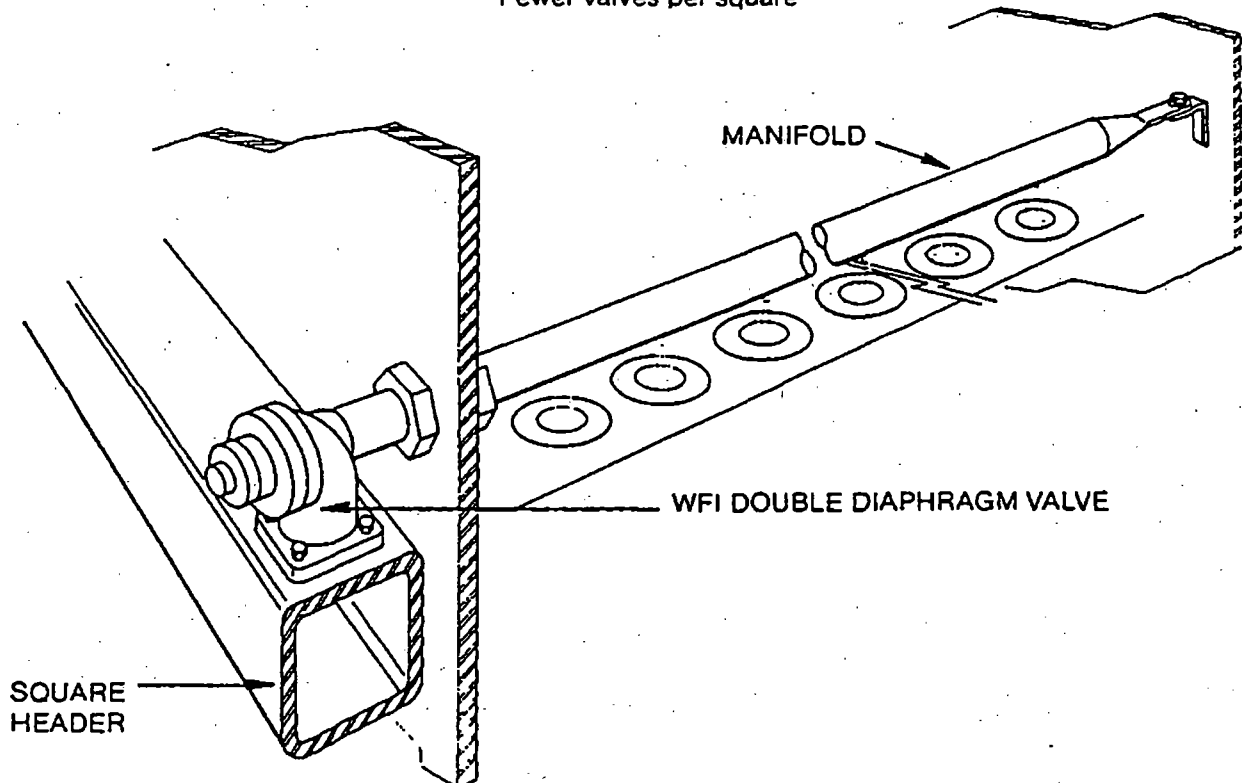

JET III

cloth areas ranging from 1,140 to 5610 square feet.

Available with full height walk-in plenums (illustrated) type 'TA' or with multiple hinged roof doors. Type 'RA'.

NOTE:

'C' dimensions for all units with bag lengths up to and including 144" include walk-in plenums. 'C' dimensions for units with bag lengths of 156" or 168" include roof doors. Dimensions subject to change without notice.

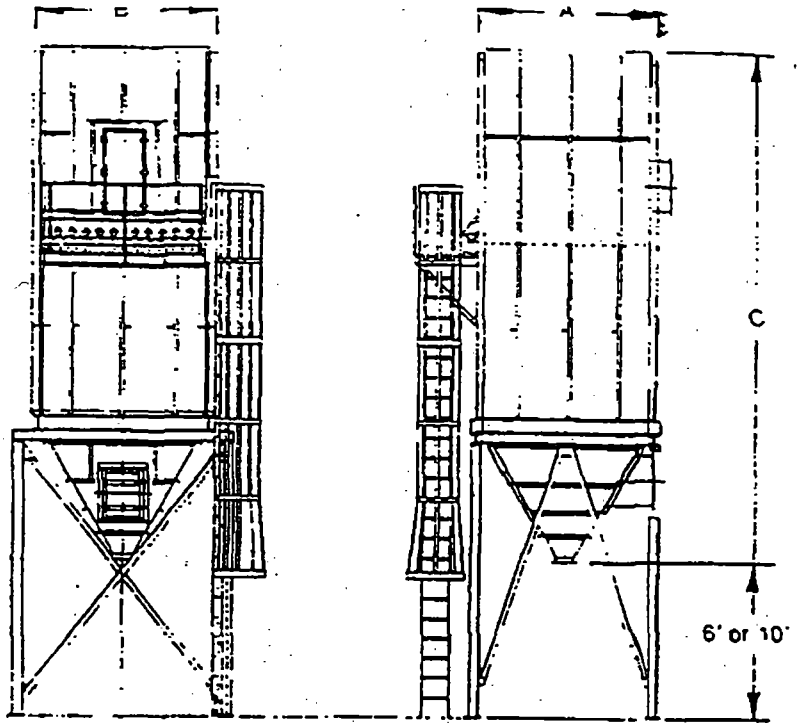

Square Modules (TA & RA) Filter Areas Sq. Ft.

Model	No. of Bags	Filter Area/Module Bag Length in Inches					
		108"	120"	132"	144"	156"	168"
99	81	1140	1270	1390	1520	—	—
1111	121	1700	1900	2080	2270	—	—
1313	169	2380	2650	2910	3170	3450	3720
1515	225	3170	3530	3880	4230	4590	4950
1715	255	3590	4000	4380	4790	5200	5610

Square Modules 'TA' Overall Dimensions

Model	'A'	'B'	'C' — Dimension Based on Bag Length in Inches					
			108	120	132	144	156	168
99	6'-5"	6'-5"	24'-0"	26'-0"	28'-0"	30'-0"	—	—
1111	7'-9"	7'-9"	25'-2"	27'-2"	29'-2"	31'-2"	—	—
1313	9'-1"	9'-1"	26'-4"	28'-4"	30'-4"	32'-4"	27'-6"	28'-6"
1515	10'-5"	10'-5"	27'-5"	29'-5"	31'-5"	33'-5"	28'-7"	29'-9"
1715	11'-8"	10'-5"	28'-6"	30'-6"	32'-6"	34'-6"	29'-8"	30'-8"

Square Modules 'RA' Overall Dimensions

Model	'A'	'B'	'C' — Dimension Based on Bag Length in Inches					
			108	120	132	144	156	168
99	6'-5"	6'-5"	21'-2"	22'-2"	23'-2"	24'-2"	—	—
1111	7'-9"	7'-9"	22'-4"	23'-4"	24'-4"	25'-4"	—	—
1313	9'-1"	9'-1"	23'-6"	24'-6"	25'-6"	26'-6"	27'-6"	28'-6"
1515	10'-5"	10'-5"	24'-7"	25'-7"	26'-7"	27'-7"	28'-7"	29'-7"
1715	11'-8"	10'-5"	25'-8"	26'-8"	27'-8"	28'-8"	29'-8"	30'-8"

NOTE! Dimensions not to be used for construction purposes.

Large Volume JET III

cloth areas ranging
from 4940 to
12870 square feet.

Available with full height walk-in
Plenums (illustrated Type "TA" or
with multiple hinged roof doors
type "RA")

Note:

"C" dimensions for all units with
bag lengths up to and including
144" include walk-in plenums
"C" dimensions for units with bag
lengths of 156" or 168" include
roof doors. Dimensions subject to
change without notice.

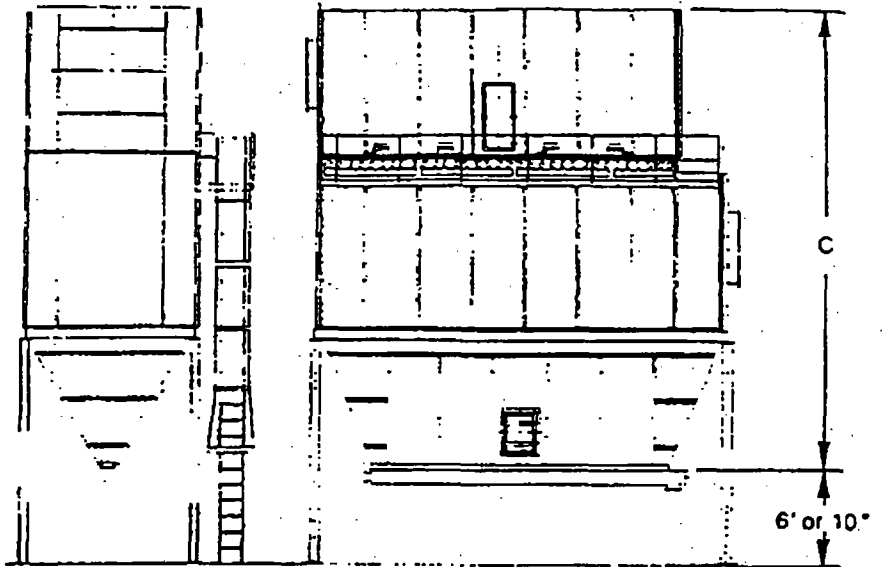

Rectangular Modules — 'TA & RA' — Filter Areas In Sq. Ft.

Model	No. of Bags	Filter Area/Module Bag Lengths In Inches		
		120	144	168
2115	315	4940	5920	6930
2415	360	5650	6770	7920
2715	405	6360	7610	8910
3015	450	7060	8460	9900
3315	495	7770	9320	10890
3615	540	847	10150	11880
3915	585	9180	11000	12870

Rectangular Modules 'TA' Overall Dimensions

Module	'A'	'B'	'C' Dimension Based on Bag Length In Inches		
			120	144	168
2115	17'-4"	10'-5"	29'-1"	33'-1"	37'-1"
2415	19'-4"	10'-5"	29'-1"	33'-1"	37'-1"
2715	22'-4"	10'-5"	29'-1"	33'-1"	37'-1"
3015	24'-4"	10'-5"	29'-1"	33'-1"	37'-1"
3315	27'-4"	10'-5"	29'-1"	33'-1"	37'-1"
3615	29'-4"	10'-5"	29'-1"	33'-1"	37'-1"
3915	32'-4"	10'-5"	29'-1"	33'-1"	37'-1"

Rectangular Modules 'RA' Overall Dimensions

Model	A	B	'C' Dimension Based on Bag Length In Inches		
			120	144	168
2115	17'-4"	10'-5"	25'-5"	27'-5"	29'-5"
2415	19'-4"	10'-5"	25'-5"	27'-5"	29'-5"
2715	22'-4"	10'-5"	25'-5"	27'-5"	29'-5"
3015	24'-4"	10'-5"	25'-5"	27'-5"	29'-5"
3315	27'-4"	10'-5"	25'-5"	27'-5"	29'-5"
3615	29'-4"	10'-5"	25'-5"	27'-5"	29'-5"
3915	32'-4"	10'-5"	25'-5"	27'-5"	29'-5"

NOTE! Dimensions not to be used for construction purposes.

Type 1000A (ROOT ACCESS)

The Type 1000 JET III Pulse-Jet Fabric Filter by Wheelabrator-Frye is available in six different sizes with filter areas between 226 and 1142 square feet. Type 1000 modules are sized for the smaller system volumes.

JET III is a wholly new design in fabric filters, offering high collection efficiency with true economy in terms of initial cost, operation, and maintenance.

Type 1000 collectors are square for convenience in connecting to the

system ductwork. All JET III Pulse-Jet Fabric Filters provide clean side access to the filter section via hinged roof doors.

The JET III design employs a unique tubesheet, filter bag, and support cage assembly which combine to save time when servicing the filter section and to ensure a positive seal against dust penetration in operation. Rebagging is a simple, one-man operation performed outside the dust environment and without the use of special tools.

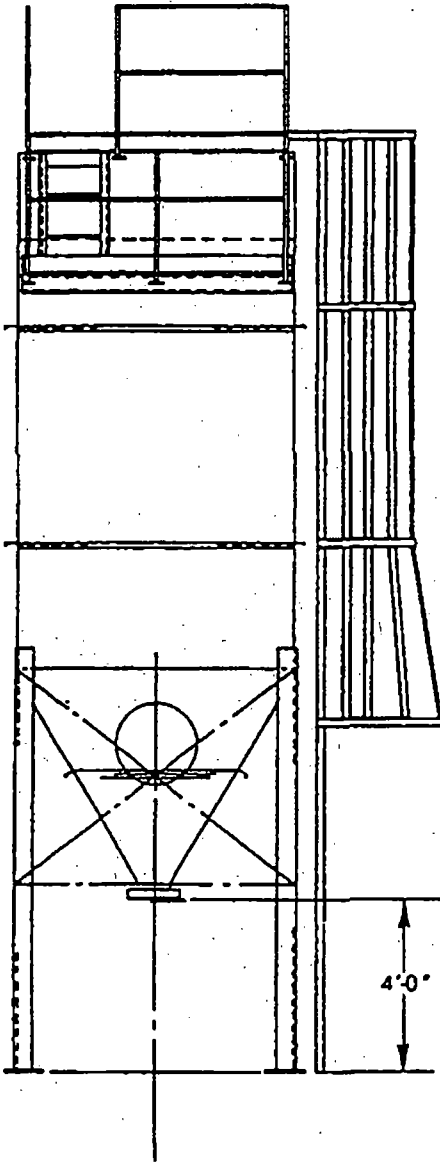

Front elevation.

Equipment Sizes

Model	No. Bags	Filter Area (sq. ft.)	Sq. Housing Size	Hopper Clearance	Overall Height* Incl. Handrailing
1016/108	16	226	36"	4'-0"	21'-0"
1025/108	25	353	44"	4'-0"	21'-6"
1036/108	36	507	52"	4'-0"	22'-2"
1049/108	49	691	60"	4'-0"	22'-10"
1064/108	64	902	68"	4'-0"	23'-5"
1081/108	81	1142	76"	4'-0"	24'-2"

*Includes support legs.

Features

Tubesheet—Wheelabrator-Frye's own integrally drawn bag colors for positive bag sealing.

Snap Ring Bag—With tubesheet, provides simple, one-step bagging operation. No additional sealing required. No tools necessary.

Venturi and Bag Support Cage—High gain throat design venturi improves cleaning efficiency and saves energy. Venturi and cage interlock for single piece assembly into the filter bag, no prior assembly of these components outside the filter housing is necessary. Venturi and cage are self-aligning within the tubesheet and bag. No clamps or hold down devices are required.

JET III Pulse Cleaning System—The square, space-saving compressed air header employs Wheelabrator-Frye's special bolt on air valves for leakproof

alignment with the air distribution manifold. JET III utilizes remote pilot valves for low-cost field wiring.

JET III Timer—The Type 1000 employs a solid state electronic timer in Nema IV enclosure with 110 volt AC solenoids.

Auxillaries—All modules are supplied with standard access ladders, walkways, and handrail to meet OSHA requirements. A complete range of hopper valves and material handling systems are available.

Standard Construction—JET III Type 1000 modules are all welded and fabricated of 12 gauge carbon steel stiffened for 15" w.g.

Shipment—JET III Type 1000 modules are shipped as one-piece units, including support legs, for simple, low-cost installation.

Air Pollution Control Division
Wheelabrator-Frye Inc.

600 Grant Street
Pittsburgh, PA 15219
(412) 288-7300

MEMBER
IGCI

EMISSIONS UNIT INFORMATION

Section [3]

Ash Handling System

III. EMISSIONS UNIT INFORMATION

Title V Air Operation Permit Application - For Title V air operation permitting only, emissions units are classified as regulated, unregulated, or insignificant. If this is an application for an initial, revised or renewal Title V air operation permit, a separate Emissions Unit Information Section (including subsections A through I as required) must be completed for each regulated and unregulated emissions unit addressed in this application. Some of the subsections comprising the Emissions Unit Information Section of the form are optional for unregulated emissions units. Each such subsection is appropriately marked. Insignificant emissions units are required to be listed at Section II, Subsection C.

Air Construction Permit or FESOP Application - For air construction permitting or federally enforceable state air operation permitting, emissions units are classified as either subject to air permitting or exempt from air permitting. The concept of an "unregulated emissions unit" does not apply. If this is an application for an air construction permit or FESOP, a separate Emissions Unit Information Section (including subsections A through I as required) must be completed for each emissions unit subject to air permitting addressed in this application for air permit. Emissions units exempt from air permitting are required to be listed at Section II, Subsection C.

Air Construction Permit and Revised/Renewal Title V Air Operation Permit Application - Where this application is used to apply for both an air construction permit and a revised or renewal Title V air operation permit, each emissions unit is classified as either subject to air permitting or exempt from air permitting for air construction permitting purposes, and as regulated, unregulated, or insignificant for Title V air operation permitting purposes. A separate Emissions Unit Information Section (including subsections A through I as required) must be completed for each emissions unit addressed in this application that is subject to air construction permitting and for each such emissions unit that is a regulated or unregulated unit for purposes of Title V permitting. (An emissions unit may be exempt from air construction permitting but still be classified as an unregulated unit for Title V purposes.) Emissions units classified as insignificant for Title V purposes are required to be listed at Section II, Subsection C.

If submitting the application form in hard copy, the number of this Emissions Unit Information Section and the total number of Emissions Unit Information Sections submitted as part of this application must be indicated in the space provided at the top of each page.

EMISSIONS UNIT INFORMATION

**Section [3]
Ash Handling System**

A. GENERAL EMISSIONS UNIT INFORMATION

Title V Air Operation Permit Emissions Unit Classification

1. Regulated or Unregulated Emissions Unit? (Check one, if applying for an initial, revised or renewal Title V air operation permit. Skip this item if applying for an air construction permit or FESOP only.)
- The emissions unit addressed in this Emissions Unit Information Section is a regulated emissions unit.
 - The emissions unit addressed in this Emissions Unit Information Section is an unregulated emissions unit.

Emissions Unit Description and Status

1. Type of Emissions Unit Addressed in this Section: (Check one)
- This Emissions Unit Information Section addresses, as a single emissions unit, a single process or production unit, or activity, which produces one or more air pollutants and which has at least one definable emission point (stack or vent).
 - This Emissions Unit Information Section addresses, as a single emissions unit, a group of process or production units and activities which has at least one definable emission point (stack or vent) but may also produce fugitive emissions.
 - This Emissions Unit Information Section addresses, as a single emissions unit, one or more process or production units and activities which produce fugitive emissions only.

2. Description of Emissions Unit Addressed in this Section:
Ash Handling System

3. Emissions Unit Identification Number: **005**

4. Emissions Unit Status Code: A	5. Commence Construction Date:	6. Initial Startup Date: 6/13/1991	7. Emissions Unit Major Group SIC Code: 49
--	--------------------------------	--	--

8. Federal Program Applicability: (Check all that apply)

- Acid Rain Unit
- CAIR Unit

9. Package Unit:
Manufacturer:

Model Number:

10. Generator Nameplate Rating: **MW**

11. Emissions Unit Comment:

The ash handling system (EU 005) receives fly ash and spray dryer reaction products (calcium sulfate, calcium chloride, calcium hydroxide, calcium fluoride). Particulate matter and visible emissions from the ash handling system are controlled by wet processing in an enclosed building.

EMISSIONS UNIT INFORMATION

**Section [3]
Ash Handling System**

Emissions Unit Control Equipment/Method: Control 1 of 2

1. Control Equipment/Method Description: Process Enclosed - Enclosed Building
2. Control Device or Method Code: 054

Emissions Unit Control Equipment/Method: Control 2 of 2

1. Control Equipment/Method Description: Dust Suppression by Water Sprays
2. Control Device or Method Code: 061

Emissions Unit Control Equipment/Method: Control ____ of ____

1. Control Equipment/Method Description:
2. Control Device or Method Code:

Emissions Unit Control Equipment/Method: Control ____ of ____

1. Control Equipment/Method Description:
2. Control Device or Method Code:

EMISSIONS UNIT INFORMATION

Section [3]
Ash Handling System

B. EMISSIONS UNIT CAPACITY INFORMATION

(Optional for unregulated emissions units.)

Emissions Unit Operating Capacity and Schedule

1. Maximum Process or Throughput Rate:		
2. Maximum Production Rate:		
3. Maximum Heat Input Rate:	million Btu/hr	
4. Maximum Incineration Rate:	pounds/hr tons/day	
5. Requested Maximum Operating Schedule:	24 hours/day 52 weeks/year	7 days/week 8,760 hours/year
6. Operating Capacity/Schedule Comment:		

EMISSIONS UNIT INFORMATION

**Section [3]
Ash Handling System**

C. EMISSION POINT (STACK/VENT) INFORMATION

(Optional for unregulated emissions units.)

Emission Point Description and Type

1. Identification of Point on Plot Plan or Flow Diagram: ASH COND		2. Emission Point Type Code:	
3. Descriptions of Emission Points Comprising this Emissions Unit for VE Tracking:			
4. ID Numbers or Descriptions of Emission Units with this Emission Point in Common:			
5. Discharge Type Code:	6. Stack Height: feet		7. Exit Diameter: feet
8. Exit Temperature: °F	9. Actual Volumetric Flow Rate: acfm		10. Water Vapor: %
11. Maximum Dry Standard Flow Rate: dscfm		12. Nonstack Emission Point Height: feet	
13. Emission Point UTM Coordinates... Zone: East (km): North (km):		14. Emission Point Latitude/Longitude... Latitude (DD/MM/SS) Longitude (DD/MM/SS)	
15. Emission Point Comment:			

EMISSIONS UNIT INFORMATION

**Section [3]
Ash Handling System**

D. SEGMENT (PROCESS/FUEL) INFORMATION

Segment Description and Rate: Segment 1 of 1

1. Segment Description (Process/Fuel Type): Industrial Processes; Mineral Products; Fugitive Emissions		
2. Source Classification Code (SCC): 3-05-888-02		3. SCC Units: Tons Product Produced
4. Maximum Hourly Rate:	5. Maximum Annual Rate:	6. Estimated Annual Activity Factor:
7. Maximum % Sulfur:	8. Maximum % Ash:	9. Million Btu per SCC Unit:
10. Segment Comment: The ash handling system receives fly ash and spray dryer reaction products such as calcium sulfate, calcium chloride, calcium hydroxide, and calcium fluoride.		

Segment Description and Rate: Segment ____ of ____

1. Segment Description (Process/Fuel Type):		
2. Source Classification Code (SCC):		3. SCC Units:
4. Maximum Hourly Rate:	5. Maximum Annual Rate:	6. Estimated Annual Activity Factor:
7. Maximum % Sulfur:	8. Maximum % Ash:	9. Million Btu per SCC Unit:
10. Segment Comment:		

EMISSIONS UNIT INFORMATION

**Section [3]
Ash Handling System**

E. EMISSIONS UNIT POLLUTANTS

List of Pollutants Emitted by Emissions Unit

1. Pollutant Emitted	2. Primary Control Device Code	3. Secondary Control Device Code	4. Pollutant Regulatory Code
PM	054	061	NS

F1. EMISSIONS UNIT POLLUTANT DETAIL INFORMATION –
POTENTIAL, FUGITIVE, AND ACTUAL EMISSIONS

(Optional for unregulated emissions units.)

Complete a Subsection F1 for each pollutant identified in Subsection E if applying for an air construction permit or concurrent processing of an air construction permit and a revised or renewal Title V operation permit. Complete for each emissions-limited pollutant identified in Subsection E if applying for an air operation permit.

Potential, Estimated Fugitive, and Baseline & Projected Actual Emissions

1. Pollutant Emitted:	2. Total Percent Efficiency of Control:
3. Potential Emissions: lb/hour tons/year	4. Synthetically Limited? <input type="checkbox"/> Yes <input type="checkbox"/> No
5. Range of Estimated Fugitive Emissions (as applicable): to tons/year	
6. Emission Factor: Reference: ?	7. Emissions Method Code:
8.a. Baseline Actual Emissions (if required): tons/year	8.b. Baseline 24-month Period: From: To:
9.a. Projected Actual Emissions (if required): tons/year	9.b. Projected Monitoring Period: <input type="checkbox"/> 5 years <input type="checkbox"/> 10 years
10. Calculation of Emissions:	
11. Potential, Fugitive, and Actual Emissions Comment:	

EMISSIONS UNIT INFORMATION

POLLUTANT DETAIL INFORMATION

Section [3]
Ash Handling System

Page [] of []

**F2. EMISSIONS UNIT POLLUTANT DETAIL INFORMATION -
ALLOWABLE EMISSIONS**

Complete Subsection F2 if the pollutant identified in Subsection F1 is or would be subject to a numerical emissions limitation.

Allowable Emissions Allowable Emissions ____ of ____

1. Basis for Allowable Emissions Code:	2. Future Effective Date of Allowable Emissions:
3. Allowable Emissions and Units:	4. Equivalent Allowable Emissions: lb/hour tons/year
5. Method of Compliance:	
6. Allowable Emissions Comment (Description of Operating Method):	

Allowable Emissions Allowable Emissions ____ of ____

1. Basis for Allowable Emissions Code:	2. Future Effective Date of Allowable Emissions:
3. Allowable Emissions and Units:	4. Equivalent Allowable Emissions: lb/hour tons/year
5. Method of Compliance:	
6. Allowable Emissions Comment (Description of Operating Method):	

Allowable Emissions Allowable Emissions ____ of ____

1. Basis for Allowable Emissions Code:	2. Future Effective Date of Allowable Emissions:
3. Allowable Emissions and Units:	4. Equivalent Allowable Emissions: lb/hour tons/year
5. Method of Compliance:	
6. Allowable Emissions Comment (Description of Operating Method):	

EMISSIONS UNIT INFORMATION

Section [3]
Ash Handling System

G. VISIBLE EMISSIONS INFORMATION

Complete Subsection G if this emissions unit is or would be subject to a unit-specific visible emissions limitation.

Visible Emissions Limitation: Visible Emissions Limitation 1 of 1

1. Visible Emissions Subtype: VE05	2. Basis for Allowable Opacity: <input checked="" type="checkbox"/> Rule <input type="checkbox"/> Other
3. Allowable Opacity: Normal Conditions: 5 % Exceptional Conditions: % Maximum Period of Excess Opacity Allowed: min/hour	
4. Method of Compliance: EPA Method 22, Annual (9 minutes per 3-hour period)	
5. Visible Emissions Comment: 40 CFR 60.58b(k) Only covers visible emissions discharged to the atmosphere from buildings or enclosures. Does not apply during maintenance and repair Does not apply inside buildings or enclosures of ash handling systems and the planned wet scrubber vent (EU006 not yet installed).	

Visible Emissions Limitation: Visible Emissions Limitation of

1. Visible Emissions Subtype:	2. Basis for Allowable Opacity: <input type="checkbox"/> Rule <input type="checkbox"/> Other
3. Allowable Opacity: Normal Conditions: % Exceptional Conditions: % Maximum Period of Excess Opacity Allowed: min/hour	
4. Method of Compliance:	
5. Visible Emissions Comment:	

EMISSIONS UNIT INFORMATION

Section [3]
Ash Handling System

H. CONTINUOUS MONITOR INFORMATION

Complete Subsection H if this emissions unit is or would be subject to continuous monitoring.

Continuous Monitoring System: Continuous Monitor ____ of ____

1. Parameter Code:	2. Pollutant(s):
3. CMS Requirement:	<input type="checkbox"/> Rule <input type="checkbox"/> Other
4. Monitor Information... Manufacturer: Model Number: Serial Number:	
5. Installation Date:	6. Performance Specification Test Date:
7. Continuous Monitor Comment:	

Continuous Monitoring System: Continuous Monitor ____ of ____

1. Parameter Code:	2. Pollutant(s):
3. CMS Requirement:	<input type="checkbox"/> Rule <input type="checkbox"/> Other
4. Monitor Information... Manufacturer: Model Number: Serial Number:	
5. Installation Date:	6. Performance Specification Test Date:
7. Continuous Monitor Comment:	

EMISSIONS UNIT INFORMATION

**Section [3]
Ash Handling System**

I. EMISSIONS UNIT ADDITIONAL INFORMATION

Additional Requirements for All Applications, Except as Otherwise Stated

1. Process Flow Diagram: (Required for all permit applications, except Title V air operation permit revision applications if this information was submitted to the department within the previous five years and would not be altered as a result of the revision being sought) <input type="checkbox"/> Attached, Document ID: _____ <input type="checkbox"/> Previously Submitted, Date _____
2. Fuel Analysis or Specification: (Required for all permit applications, except Title V air operation permit revision applications if this information was submitted to the department within the previous five years and would not be altered as a result of the revision being sought) <input type="checkbox"/> Attached, Document ID: _____ <input type="checkbox"/> Previously Submitted, Date _____
3. Detailed Description of Control Equipment: (Required for all permit applications, except Title V air operation permit revision applications if this information was submitted to the department within the previous five years and would not be altered as a result of the revision being sought) <input type="checkbox"/> Attached, Document ID: _____ <input type="checkbox"/> Previously Submitted, Date _____
4. Procedures for Startup and Shutdown: (Required for all operation permit applications, except Title V air operation permit revision applications if this information was submitted to the department within the previous five years and would not be altered as a result of the revision being sought) <input type="checkbox"/> Attached, Document ID: _____ <input type="checkbox"/> Previously Submitted, Date _____ <input checked="" type="checkbox"/> Not Applicable (construction application)
5. Operation and Maintenance Plan: (Required for all permit applications, except Title V air operation permit revision applications if this information was submitted to the department within the previous five years and would not be altered as a result of the revision being sought) <input type="checkbox"/> Attached, Document ID: _____ <input type="checkbox"/> Previously Submitted, Date _____ <input checked="" type="checkbox"/> Not Applicable
6. Compliance Demonstration Reports/Records: <input type="checkbox"/> Attached, Document ID: _____ Test Date(s)/Pollutant(s) Tested: _____ <input type="checkbox"/> Previously Submitted, Date: _____ Test Date(s)/Pollutant(s) Tested: _____ <input type="checkbox"/> To be Submitted, Date (if known): _____ Test Date(s)/Pollutant(s) Tested: _____ <input type="checkbox"/> Not Applicable Note: For FESOP applications, all required compliance demonstration records/reports must be submitted at the time of application. For Title V air operation permit applications, all required compliance demonstration reports/records must be submitted at the time of application, or a compliance plan must be submitted at the time of application.
7. Other Information Required by Rule or Statute: <input type="checkbox"/> Attached, Document ID: _____ <input checked="" type="checkbox"/> Not Applicable

EMISSIONS UNIT INFORMATION

Section [3]

Ash Handling System

I. EMISSIONS UNIT ADDITIONAL INFORMATION (CONTINUED)

Additional Requirements for Air Construction Permit Applications

1. Control Technology Review and Analysis (Rules 62-212.400(10) and 62-212.500(7), F.A.C.; 40 CFR 63.43(d) and (e)): <input type="checkbox"/> Attached, Document ID: _____ <input type="checkbox"/> Not Applicable
2. Good Engineering Practice Stack Height Analysis (Rules 62-212.400(4)(d) and 62-212.500(4)(f), F.A.C.): <input type="checkbox"/> Attached, Document ID: _____ <input type="checkbox"/> Not Applicable
3. Description of Stack Sampling Facilities: (Required for proposed new stack sampling facilities only). <input type="checkbox"/> Attached, Document ID: _____ <input type="checkbox"/> Not Applicable

Additional Requirements for Title V Air Operation Permit Applications

1. Identification of Applicable Requirements: <input type="checkbox"/> Attached, Document ID: _____
2. Compliance Assurance Monitoring: <input type="checkbox"/> Attached, Document ID: _____ <input checked="" type="checkbox"/> Not Applicable
3. Alternative Methods of Operation: <input type="checkbox"/> Attached, Document ID: _____ <input checked="" type="checkbox"/> Not Applicable
4. Alternative Modes of Operation (Emissions Trading): <input type="checkbox"/> Attached, Document ID: _____ <input checked="" type="checkbox"/> Not Applicable

Additional Requirements Comment

--