

SOUTHEAST DISTRICT PERMIT PROCESSING WORKSHEET

LOGGING

NAME OF PROJECT

(Lime Silo Vent)
North Broward Resource Recovery Fac.

PROJECT LOG NO.

AC 06-186997 COUNTY Broward

DATE APPLICATION RECEIVED

9/27/90

30-DAY (HW 60-DAY) DATE

10/26/90

AMOUNT OF FEE PAID

Permit # 15785 \$200.00

COPIES OF PLANS

COPIES OF APPLICATION

4

COPIES OF SPECIFICATIONS

COPIES TO: CORPS

LOCAL PROGRAM

TALLAHASSEE

DNR

OTHER

9/27/90 (cover letter only)

PERMIT REVIEW

PERMIT ASSIGNED TO

Sittig, M.

AMOUNT OF FEE REQ'D \$

DISCHARGE TO OR LOCATED IN AQUATIC PRESERVE:

Yes

No

N/A

PERMIT STATUS AND CHRONOLOGY

DATE	REVIEWER'S INITIALS	COMMENTS

(continue on reverse side)

FIELD INSPECTION BY:

DATE

; N/A

WATER MANAGEMENT COMMENTS (DATE)

; N/A

LOCAL PROGRAM APPROVAL (DATE)

; N/A

GPSI, APIS, OR PWS UPDATE DRAFTED: Yes

; N/A

PUBLIC NOTICE LETTER ISSUED/PUBLISHED (DATES)

; N/A

APPLICATION COMPLETION DATE

> DEFAULT DATE

>> D.A.S.

90+ DAYS INACTIVITY AUTHORIZATION:

OK

DENY

<<

COMMENTS:

PERMIT, EXEMPTION, DENIAL DRAFTED BY:

DATE:

INTENT: PROGRAM HEAD

PROGRAM ADM.

FINAL DRAFT REVIEWED BY:

DATE:

FINAL DRAFT APPROVED BY:

DATE:

DEPARTMENT OF ENVIRONMENTAL REGULATION

AC 06-186997

APPLICATION TO OPERATE/CONSTRUCT AIR POLLUTION SOURCES

SOURCE TYPE: Refuse-to-Energy Facility [X] New [] Existing¹

APPLICATION TYPE: [X] Construction [] Operation [] Modification

COMPANY NAME: Wheelabrator North Broward Inc. COUNTY: Broward

Identify the specific emission point source(s) addressed in this application (i.e., Lime Kiln No. 4 with Venturi Scrubber; Peaking Unit No. 2, Gas Fired) Ash Conditioner Room Fabric Filter

SOURCE LOCATION: Street 2700 Hilton Road (NW 48th Street) City Pompano Beach

UTM: East 583,900 meters North 2,907,600 meters

Latitude 26° 17' 14" N Longitude 80° 9' 35" W

APPLICANT NAME AND TITLE: Wheelabrator North Broward Inc.

APPLICANT ADDRESS: 4400 S. State Road 7, Fort Lauderdale, FL 33314

SECTION I: STATEMENTS BY APPLICANT AND ENGINEER

A. APPLICANT

I am the undersigned owner or authorized representative^{*} of Wheelabrator North Broward Inc.

I certify that the statements made in this application for a construction permit are true, correct and complete to the best of my knowledge and belief. Further, I agree to maintain and operate the pollution control source and pollution control facilities in such a manner as to comply with the provision of Chapter 403, Florida Statutes, and all the rules and regulations of the department and revisions thereof. I also understand that a permit, if granted by the department, will be non-transferable and I will promptly notify the department upon sale or legal transfer of the permitted establishment.

*Attach letter of authorization

Signed: [Signature]
James R. Wiegner, Project Manager
Name and Title (Please Type)

Date: 9/26/90 Telephone No. (305) 581-6606

B. PROFESSIONAL ENGINEER REGISTERED IN FLORIDA (where required by Chapter 471, F.S.)

This is to certify that the engineering features of this pollution control project have been designed/examined by me and found to be in conformity with modern engineering principles applicable to the treatment and disposal of pollutants characterized in the permit application. There is reasonable assurance, in my professional judgement, that

¹See Florida Administration Code Rule 17-2.100(57) and (104)

the pollution control facilities, when properly maintained and operated, will discharge an effluent that complies with all applicable statutes of the State of Florida and the rules and regulations of the department. It is also agreed that the undersigned will furnish, if authorized by the owner, the applicant a set of instructions for the proper maintenance and operation of the pollution control facilities and, if applicable, pollution sources.

Signed Kennard F. Kosky
Kennard F. Kosky
Name (Please Type)
KBN Engineering and Applied Sciences, Inc.
Company Name (Please Type)
1034 NW 57th Street, Gainesville, FL 32605
Mailing Address (Please Type)

Florida Registration No. 14996 Date: June 5, 1990 Telephone No. (904) 331-9000

SECTION II: GENERAL PROJECT INFORMATION

- A. Describe the nature and extent of the project. Refer to pollution control equipment, and expected improvements in source performance as a result of installation. State whether the project will result in full compliance. Attach additional sheet if necessary.

A fabric filter dust collector (baghouse) will be installed on the vent from the ash conditioner room to control dust.

- B. Schedule of project covered in this application (Construction Permit Application Only)

Start of Construction August 1, 1990 Completion of Construction August 1, 1991

- C. Costs of pollution control system(s): (Note: Show breakdown of estimated costs only for individual components/units of the project serving pollution control purposes. Information on actual costs shall be furnished with the application for operation permit.)

\$40,000

- D. Indicate any previous DER permits, orders and notices associated with the emission point, including permit issuance and expiration dates.

Power Plant Site Certification PA 86-22; PSD-FL-112

E. Requested permitted equipment operating time: hrs/day 24; days/wk 7; wks/yr 52;
If power plant, hrs/yr _____; if seasonal, describe: _____

F. If this is a new source or major modification, answer the following questions.
(Yes or No)

1. Is this source in a non-attainment area for a particular pollutant? NA¹
 - a. If yes, has "offset" been applied? _____
 - b. If yes, has "Lowest Achievable Emission Rate" been applied? _____
 - c. If yes, list non-attainment pollutants. _____
 2. Does best available control technology (BACT) apply to this source?
If yes, see Section VI. Yes²
 3. Does the State "Prevention of Significant Deterioration" (PSD) requirement apply to
this source? If yes, see Sections VI and VII. Yes³
 4. Do "Standards of Performance for New Stationary Sources" (NSPS) apply to this
source? No
 5. Do "National Emission Standards for Hazardous Air Pollutants" (NESHAP) apply to this
source? No
- H. Do "Reasonably Available Control Technology" (RACT) requirements apply to this
source? No
- a. If yes, for what pollutants? _____
 - b. If yes, in addition to the information required in this form, any information
requested in Rule 17-2.650 must be submitted.

Attach all supportive information related to any answer of "Yes". Attach any
justification for any answer of "No" that might be considered questionable.

¹Broward County is nonattainment for ozone; the applicable pollutant is volatile
organic compounds (VOCs). This source will not emit VOCs.

²BACT for emission type is baghouse as identified by EPA's BACT/LAER clearinghouse
documents.

³PSD applies since the total particulate matter/PM10 emissions from the resource
recovery facility are greater than the significant emission amounts. PSD modeling and
BACT analysis were performed for the municipal solid-waste-fired boilers. Because the
emissions from this source are extremely low and well less than the significant
emission levels, modeling of this source was considered unnecessary.

SECTION III: AIR POLLUTION SOURCES & CONTROL DEVICES (Other than Incinerators)

A. Raw Materials and Chemicals Used in your Process, if applicable:

Description	Contaminants		Utilization Rate - lbs/hr	Relate to Flow Diagram
	Type	% Wt		
Flyash and spray dryer reaction products			17,577	Attachment C
Water			3,858	Attachment C

B. Process Rate, if applicable: (See Section V, Item 1)

- Total Process Input Rate (lbs/hr): 21,435
- Product Weight (lbs/hr): 21,435

C. Airborne Contaminants Emitted: (Information in this table must be submitted for each emission point, use additional sheets as necessary)

Name of Contaminant	Emission ¹		Allowed ² Emission Rate per Rule 17-2	Allowable ³ Emission lbs/hr	Potential Emission		Relate to Flow Diagram
	Maximum lbs/hr	Actual T/yr			lbs/hr	T/yr	
Particulate	0.69	3.0	17-2.610(1)(b)	15.6	137.1	600.7	Att. C

¹See Section V, Item 2.

²Reference applicable emission standards and units (e.g. Rule 17-2.600(5)(b)2. Table II, E. (1) - 0.1 pounds per million BTU heat input)

³Calculated from operating rate and applicable standard.

D. Control Devices: (See Section V, Item 4)

Name and Type (Model & Serial No.)	Contaminant	Efficiency	Range of Particles Size Collected (in microns) (If applicable)	Basis for Efficiency (Section V Item 5)
Bag Filter	Particulate	99%+	>0.3 μ m	Att. A
MAC Filter Model				
120 LST 100				

E. Fuels

Not Applicable

Type (Be Specific)	Consumption*		Maximum Heat Input (MMBTU/hr)
	avg/hr	max./hr	

Units: Natural Gas--MMCF/hr; Fuel Oils--gallons/hr; Coal, wood, refuse, others--lbs/hr.

Fuel Analysis:

Percent Sulfur: _____ Percent Ash: _____

Density: _____ lbs/gal Typical Percent Nitrogen: _____

Heat Capacity: _____ BTU/lb _____ BTU/gal

Other Fuel Contaminants (which may cause air pollution): _____

F. If applicable, indicate the percent of fuel used for space heating.

Annual Average _____ Maximum _____

G. Indicate liquid or solid wastes generated and method of disposal.

H. Emission Stack Geometry and Flow Characteristics (Provide data for each stack):

Horizontal Discharge
 Stack Height: 60 ft. Stack Diameter: 28 in x 18 in
 Gas Flow Rate: 8,000 ACFM DSCFM Gas Exit Temperature: 40 to 100 °F.
 Water Vapor Content: 60 to 95 % Velocity: 38.1 FPS
 (relative humidity)

SECTION IV: INCINERATOR INFORMATION

Type of Waste	Type 0 (Plastics)	Type II (Rubbish)	Type III (Refuse)	Type IV (Garbage)	Type IV (Pathological)	Type V (Liq. & Gas By-prod.)	Type VI (Solid By-prod.)
Actual lb/hr Incinerated							
Uncontrolled (lbs/hr)							

Description of Waste _____
 Total Weight Incinerated (lbs/hr) _____ Design Capacity (lbs/hr) _____
 Approximate Number of Hours of Operation per day _____ day/wk _____ wks/yr. _____
 Manufacturer _____
 Date Constructed _____ Model No. _____

	Volume (ft) ³	Heat Release (BTU/hr)	Fuel		Temperature (°F)
			Type	BTU/hr	
Primary Chamber					
Secondary Chamber					

Stack Height: _____ ft. Stack Diameter: _____ Stack Temp. _____
 Gas Flow Rate: _____ ACFM _____ DSCFM Velocity: _____ FPS

*If 50 or more tons per day design capacity, submit the emissions rate in grains per standard cubic foot dry gas corrected to 50% excess air.

Type of pollution control devices: Cyclone Wet Scrubber Afterburner
 Other (specify) _____

Brief description of operating characteristics of control devices: _____

Ultimate disposal of any effluent other than that emitted from the stack (scrubber water, ash, etc.):

Flyash dust collected will be discharged via enclosed chute to the enclosed conveyor feeding the ash conditioners.

NOTE: Items 2, 3, 4, 6, 7, 8, and 10 in Section V must be included where applicable.

SECTION V: SUPPLEMENTAL REQUIREMENTS

Please provide the following supplements where required for this application.

1. Total process input rate and product weight -- show derivation [Rule 17-2.100(127)]
See Attachment A
2. To a construction application, attach basis of emission estimate (e.g., design calculations, design drawings, pertinent manufacturer's test data, etc.) and attach proposed methods (e.g., FR Part 60 Methods, 1, 2, 3, 4, 5) to show proof of compliance with applicable standards. To an operation application, attach test results or methods used to show proof of compliance. Information provided when applying for an operation permit from a construction permit shall be indicative of the time at which the test was made.
See Attachment A
3. Attach basis of potential discharge (e.g., emission factor, that is, AP42 test).
See Attachment A
4. With construction permit application, include design details for all air pollution control systems (e.g., for baghouse include cloth to air ratio; for scrubber include cross-section sketch, design pressure drop, etc.)
See Attachment B
5. With construction permit application, attach derivation of control device(s) efficiency. Include test or design data. Items 2, 3 and 5 should be consistent: actual emissions = potential (1-efficiency).
See Attachment A
6. An 8 ½" x 11" flow diagram which will, without revealing trade secrets, identify the individual operations and/or processes. Indicate where raw materials enter, where solid and liquid waste exit, where gaseous emissions and/or airborne particles are evolved and where finished products are obtained.
See Attachment C
7. An 8 ½" x 11" plot plan showing the location of the establishment, and points of airborne emissions, in relation to the surrounding area, residences and other permanent structures and roadways (Examples: Copy of relevant portion of USGS topographic map).
See Attachment D
8. An 8 ½" x 11" plot plan of facility showing the location of manufacturing processes and outlets for airborne emissions. Relate all flows to the flow diagram.
See Attachment D

9. The appropriate application fee in accordance with Rule 17-4.05. The check should be made payable to the Department of Environmental Regulation.
10. With an application for operation permit, attach a Certificate of Completion of Construction indicating that the source was constructed as shown in the construction permit.

SECTION VI: BEST AVAILABLE CONTROL TECHNOLOGY

A. Are standards of performance for new stationary sources pursuant to 40 C.F.R. Part 60 applicable to the source?

Yes No

Contaminant	Rate or Concentration

B. Has EPA declared the best available control technology for this class of sources (If yes, attach copy)

Yes No

Contaminant	Rate or Concentration
Particulate Matter	99+ percent efficiency down to 0.01 gr/scf (see EPA BACT/LAER Clearinghouse Documents, 1985, 1986, 1987, 1988, and 1989)

C. What emission levels do you propose as best available control technology?

Contaminant	Rate or Concentration
Particulate Matter	99+ percent efficiency/0.01 gr/acf

D. Describe the existing control and treatment technology (if any).

- | | |
|---------------------------|--------------------------|
| 1. Control Device/System: | 2. Operating Principles: |
| 3. Efficiency: | 4. Capital Costs: |

*Explain method of determining

- j. Applicability to manufacturing processes:
 - k. Ability to construct with control device, install in available space, and operate within proposed levels:
- 3.
- a. Control Device:
 - b. Operating Principles:
 - c. Efficiency:¹
 - d. Capital Cost:
 - e. Useful Life:
 - f. Operating Cost:
 - g. Energy:²
 - h. Maintenance Cost:
 - i. Availability of construction materials and process chemicals:
 - j. Applicability to manufacturing processes:
 - k. Ability to construct with control device, install in available space, and operate within proposed levels:
- 4.
- a. Control Device:
 - b. Operating Principles:
 - c. Efficiency:¹
 - d. Capital Cost:
 - e. Useful Life:
 - f. Operating Cost:
 - g. Energy:²
 - h. Maintenance Cost:
 - i. Availability of construction materials and process chemicals:
 - j. Applicability to manufacturing processes:
 - k. Ability to construct with control device, install in available space, and operate within proposed levels:

F. Describe the control technology selected:

- 1. Control Device:
- 2. Efficiency:¹
- 3. Capital Cost:
- 4. Useful Life:
- 5. Operating Cost:
- 6. Energy:²
- 7. Maintenance Cost:
- 8. Manufacturer:
- 9. Other locations where employed on similar processes:
 - a. (1) Company:
 - (2) Mailing Address:
 - (3) City:
 - (4) State:

¹Explain method of determining efficiency.

²Energy to be reported in units of electrical power - KWH design rate.

(5) Environmental Manager:

(6) Telephone No.:

(7) Emissions:¹

Contaminant	Rate or Concentration

(8) Process Rate:¹

b. (1) Company:

(2) Mailing Address:

(3) City:

(4) State:

(5) Environmental Manager:

(6) Telephone No.:

(7) Emissions:¹

Contaminant	Rate or Concentration

(8) Process Rate:¹

10. Reason for selection and description of systems:

¹Applicant must provide this information when available. Should this information not be available, applicant must state the reason(s) why.

SECTION VII - PREVENTION OF SIGNIFICANT DETERIORATION

Not Applicable

A. Company Monitored Data

1. _____ no. sites _____ TSP _____ () SO²* _____ Wind spd/dir

Period of Monitoring _____ / _____ / _____ to _____ / _____ / _____
month day year month day year

Other data recorded _____

Attach all data or statistical summaries to this application.

*Specify bubbler (B) or continuous (C).

2. Instrumentation, Field and Laboratory

- a. Was instrumentation EPA referenced or its equivalent? [] Yes [] No
- b. Was instrumentation calibrated in accordance with Department procedures?
[] Yes [] No [] Unknown

B. Meteorological Data Used for Air Quality Modeling

- 1. _____ Year(s) of data from _____ / _____ / _____ to _____ / _____ / _____
month day year month day year
- 2. Surface data obtained from (location) _____
- 3. Upper air (mixing height) data obtained from (location) _____
- 4. Stability wind rose (STAR) data obtained from (location) _____

C. Computer Models Used

- 1. _____ Modified? If yes, attach description.
- 2. _____ Modified? If yes, attach description.
- 3. _____ Modified? If yes, attach description.
- 4. _____ Modified? If yes, attach description.

Attach copies of all final model runs showing input data, receptor locations, and principle output tables.

D. Applicants Maximum Allowable Emission Data

Pollutant	Emission Rate
TSP	_____ grams/sec
SO ²	_____ grams/sec

E. Emission Data Used in Modeling

Attach list of emission sources. Emission data required is source name, description of point source (on NEDS point number), UTM coordinates, stack data, allowable emissions, and normal operating time.

F. Attach all other information supportive to the PSD review.

G. Discuss the social and economic impact of the selected technology versus other applicable technologies (i.e, jobs, payroll, production, taxes, energy, etc.). Include assessment of the environmental impact of the sources.

H. Attach scientific, engineering, and technical material, reports, publications, journals, and other competent relevant information describing the theory and application of the requested best available control technology.

ATTACHMENT A

ASH CONDITIONER ROOM FABRIC FILTER
AIR PERMIT CALCULATIONS

A. Calculate lb/hr particulate emission using
0.01 grain/ACF (Vendor guarantee)

$$\frac{8000 \text{ ACF/min} \times 0.01 \text{ gr/acf} / 7000 \text{ gr/lb} \times 60 \text{ min/hr}}{0.69 \text{ lb/hr}} =$$

B. Calculate tons/year (t/yr) particulate emissions

$$\frac{0.69 \text{ lb/hr} \times 8760 \text{ hr/yr} / 2000 \text{ lb/ton}}{3.00 \text{ t/yr}} =$$

C. Calculate lb/hr potential (uncontrolled) emissions using
2.0 grain/ACF

$$\frac{8000 \text{ ACF/min} \times 2.0 \text{ gr/acf} / 7000 \text{ gr/lb} \times 60 \text{ min/hr}}{137.1 \text{ lb/hr}} =$$

D. Calculate tons/year (t/yr) uncontrolled particulate emissions

$$\frac{137.1 \text{ lb/hr} \times 8760 \text{ hr/yr} / 2000 \text{ lb/ton}}{600.7 \text{ t/yr}} =$$

E. Calculate exit velocity for 28" X 18" horizontal discharge

$$\frac{28'' \times 18'' / 8000 \text{ ft}^3/\text{min}}{3.5 \text{ ft}^2 / 60 \text{ sec/min}} = \frac{144 \text{ sq in. per sq. ft} \times 3.5 \text{ ft}^2}{38.1 \text{ ft/sec}} =$$

By: _____

Checked: MLM

ATTACHMENT B



MAC

P.O. Box 205 • Sabetha, Kansas 66534 • Toll Free 1-800-223-2191
or in Kansas Call Collect 913-284-2191

FAX 913-284-3585

SECTION **2**

**DATA SHEET
AIR VENT FILTERS**
Effective Date 12-1-87
Supersedes 12-1-86

LST FILTER

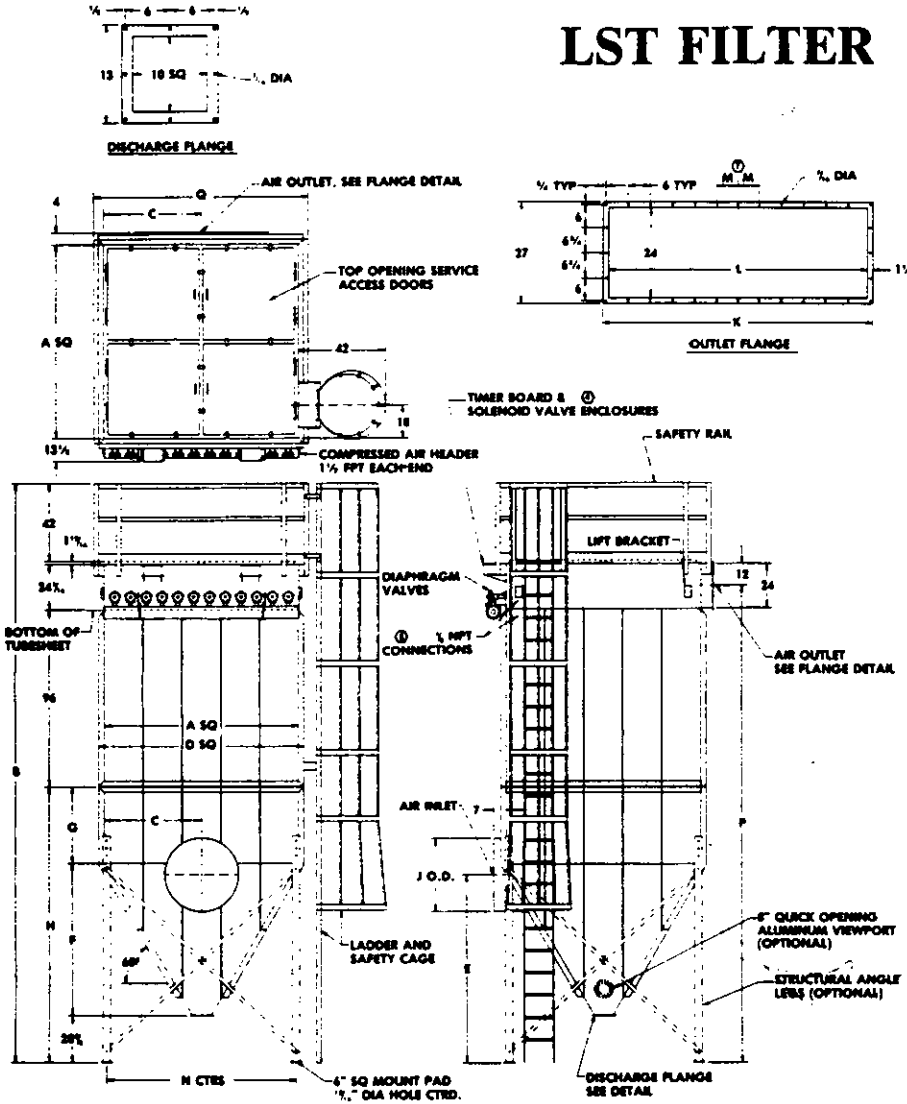

STANDARD SPECS. FOR MAC MODEL LST FILTERS
Materials of Construction

12 ga. reinforced carbon steel for 17" W.C.
Full welded exterior except reinforcing, skip welded interior

Arrangement

Header at 6:00
Air outlet at 12:00
Ladder & Safety Cage at 3:00
Air inlet at 6:00
Housing and hopper are rotatable in 90° increments except that ladder and inlet cannot be on same side

Major Components

Clean air plenum with hinged top doors and welded-in tubesheet
One-Piece welded top plenum and baghouse assy.
Flanged air outlet
Removable internal air piping
6" compressed air header
Combination venturi and bag cage
Snap band 12 oz. singed polyester bags
1" diaphragm air valves for LST64 and LST81
1 1/2" diaphragm air valves for LST100 and LST144
Timer board enclosure NEMA 12
Top guard rail
Ladder and safety cage
Pressure differential gauge kit
60° hopper flanged to housing
Round inlet stub

Painting

Standard cleaning and metal preparation
Exterior and clean air plenum interior primed with one coat 32x29 gray primer
Exterior to have 1 finish coat, color to be specified
Standard colors are MAC Green, Blue or White

NOTES:

1. All dimensions are in inches.
2. Const. is 12 ga. HRCs reinforced. Filters stressed for 17" W.G.
3. Filter cleaning mechanism requires clean, dry plant air at 90-100 PSIG. See schedule for SCFM cleaning air.
4. Timer board and solenoid valve enclosure requires 110 V. 60 HZ. power supply. Model LST144 has two enclosures, each of which requires a power supply. NEMA 12 enclosure standard. NEMA 4 and NEMA 9 enclosures optional.
5. Housing and hopper are installation rotatable in 90° increments.
6. Top opening service doors open from center.
7. XXXLST81 outlet flange does not have center hole.
8. 1/2" NPT must have pipe plug if differential pres. ga. is not used.

DIMENSIONS AND SPECIFICATIONS	MODEL											
	96LST64	120LST64	144LST64	96LST81	120LST81	144LST81	96LST100	120LST100	144LST100	96LST144	120LST144	144LST144
CLOTH AREA	845	1062	1280	1069	1345	1620	1320	1680	2000	1901	2390	2880
NO. OF BAGS	64	64	64	81	81	81	100	100	100	144	144	144
SCFM CLEANING AIR	10	10	10	10	10	10	21	21	21	42	42	42
A	70 1/2	70 1/2	70 1/2	79	79	79	87 1/2	87 1/2	87 1/2	104 1/2	104 1/2	104 1/2
B	262 1/2	286 1/2	310 1/2	270 1/2	294 1/2	318 1/2	277 1/2	301 1/2	325 1/2	292 1/2	316 1/2	340 1/2
C	35 1/2	35 1/2	35 1/2	39 1/2	39 1/2	39 1/2	43 1/2	43 1/2	43 1/2	52 1/2	52 1/2	52 1/2
D	76 1/2	76 1/2	76 1/2	85	85	85	93 1/2	93 1/2	93 1/2	110 1/2	110 1/2	110 1/2
E	82 1/2	82 1/2	82 1/2	87 1/2	87 1/2	87 1/2	92 1/2	92 1/2	92 1/2	104 1/2	104 1/2	104 1/2
F	52 1/2	52 1/2	52 1/2	60 1/2	60 1/2	60 1/2	67 1/2	67 1/2	67 1/2	82 1/2	82 1/2	82 1/2
G	18	42	66	18	42	66	18	42	66	18	42	66
H	99 1/2	123 1/2	147 1/2	106 1/2	130 1/2	154 1/2	113 1/2	137 1/2	161 1/2	128 1/2	152 1/2	176 1/2
J	26	26	26	30	30	30	34	34	34	40	40	40
K	35	35	35	43	43	43	51	51	51	73	73	73
L	32	32	32	40	40	40	48	48	48	70	70	70
M	4 1/2	4 1/2	4 1/2	2 1/2	2 1/2	2 1/2	6 1/2	6 1/2	6 1/2	5 1/2	5 1/2	5 1/2
N	68 1/2	68 1/2	68 1/2	77 1/2	77 1/2	77 1/2	85 1/2	85 1/2	85 1/2	102	102	102
P	207 1/2	231 1/2	255 1/2	214 1/2	238 1/2	262 1/2	221 1/2	245 1/2	269 1/2	236 1/2	260 1/2	284 1/2
Q	81 1/2	81 1/2	81 1/2	90 1/2	90 1/2	90 1/2	98 1/2	98 1/2	98 1/2	115 1/2	115 1/2	115 1/2
WEIGHT	4180	4460	4950	5030	5370	5980	5980	6370	7100	7450	7850	8750



PULSE JET FILTERS

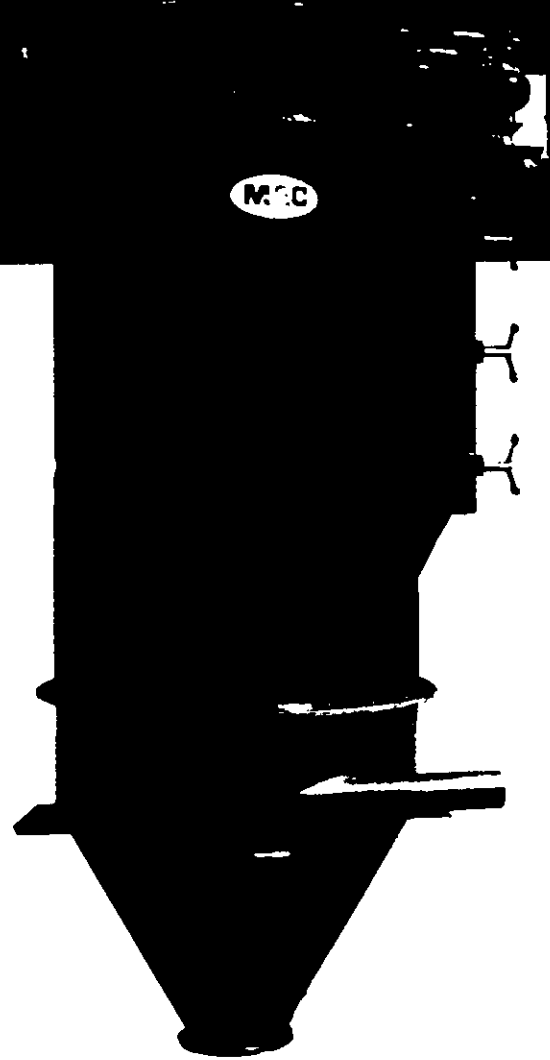
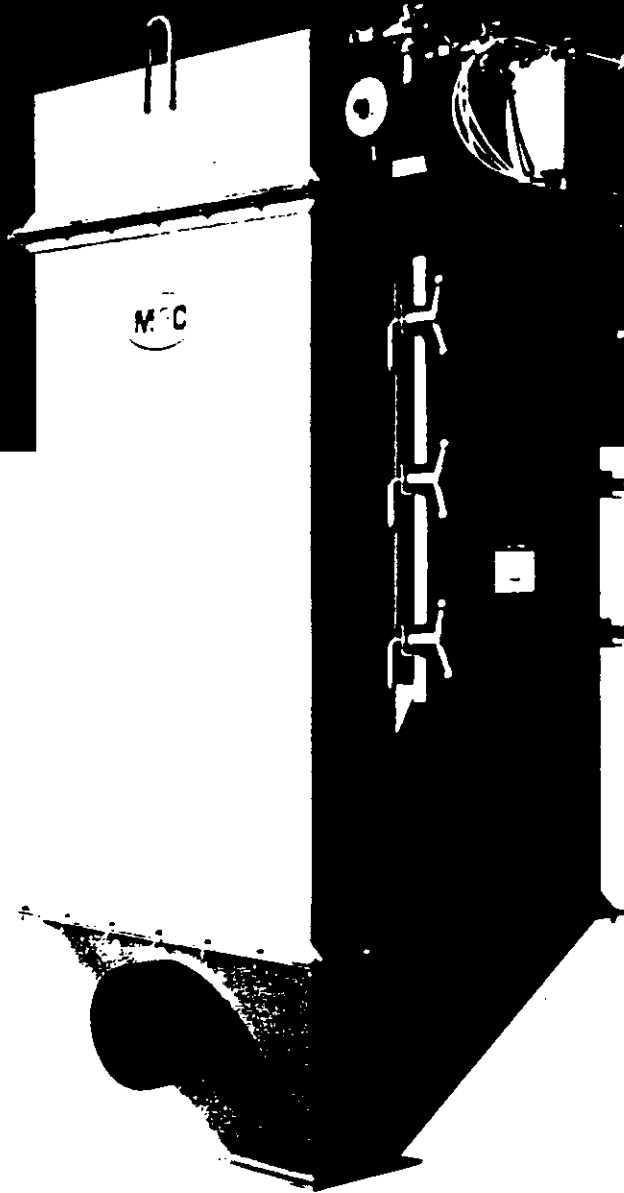

Introduction

Mac Offers 5 Models of Small, Modular Pulse Jet Filters.

Each MAC Pulse Jet Filter is designed for a variety of applications and the product line, as a whole, will meet almost any requirement for pulse jet filters in our size range. MAC has 5 models of small, modular Pulse Jet Filters. They are "AVS" (Air-Vent Square), "AVR" (Air Vent Round), "ST" (Square-Top Bag Removal), "LST" (Large Square-Top Bag Removal) and "RT" (Round-Top Bag Removal). Larger Pulse Jet Filters are available in the RPT line. The "AVR" and "RT" filters can be furnished with an optional tangential pneumatic receiver section when used in conjunction with pneumatic conveying systems.

Rely on Our Engineers to Help You Select a Filter to Meet Your Particular Application.

All MAC Pulse Jet Filters will effectively filter such materials as grain, metallurgical fume, feed, coal, flour, cement, limestone, fly ash, sugar and a variety of chemical solids. The engineers at MAC will select the proper model, size and fabric for your particular application. With our experience of over 18 years in the manufacturing business, chances are good that we have successfully handled the majority of applications in the past.

The Filter Bags in All MAC Pulse Jet Models are Cleaned by Compressed Air.

The filters operate as follows. Dust laden air enters the unit and passes from the outside to the inside of the cage-supported tubular filter bags. The dust is retained on the exterior of the filter bag while the cleaned air flows upward through the bag and exits via the venturi at the top of the bag into the clean air plenum.

Bag Cleaning is Controlled by an Electric Timer — Controlling the Cleaning of Each Row of Bags.

Upon actuation by the timer, a large capacity diaphragm valve opens the header pipe above a row of bags for a duration of 20 to 40 milliseconds. Compressed air nozzles located in the header pipe above each venturi direct the air into the individual filter bags. As the compressed air enters the venturi, filtration is momentarily stopped. As the compressed air bubble travels down the length of the bag, the fabric and the dust are accelerated away from the cage. The bag reaches its elastic limit and its movement is halted while inertia causes the dust to continue to move and thus separates it from the bag surface. The dust is discharged at the base of the filter. All models feature no-moving-parts construction and operate with minimal maintenance. The timer is completely adjustable with regard to cycle and pulse duration to minimize compressed air usage.

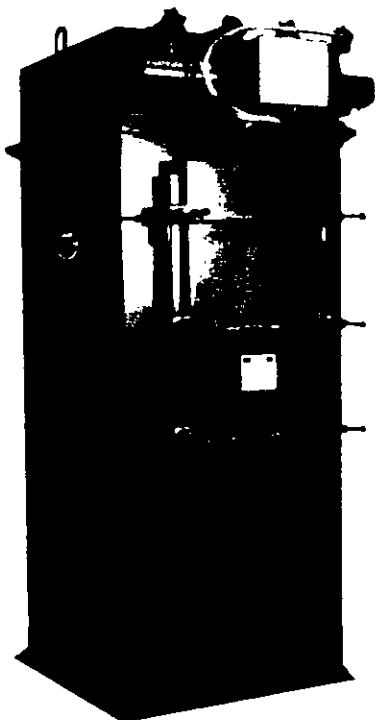

AVS

The "AVS" filter is suitable for systems where the operating static pressure ranges between -17" W.C. to +17" W.C. The "AVS" models contain up to 850 square feet of cloth and can handle up to 8500 CFM at a 10 to 1 air to cloth ratio.

AVR

The "AVR" filter is designed for those systems which operate at higher static pressure levels, up to 17" Hg. The MAC "AVR" filter can be supplied with an optional tangential pneumatic receiver. This receiver is recommended for heavy dust loads or for applications in which the filter is used as a pneumatic receiver. The tangential inlet together with an inner cyclone ring, protects the bags from wear by abrasive and high velocity particles.

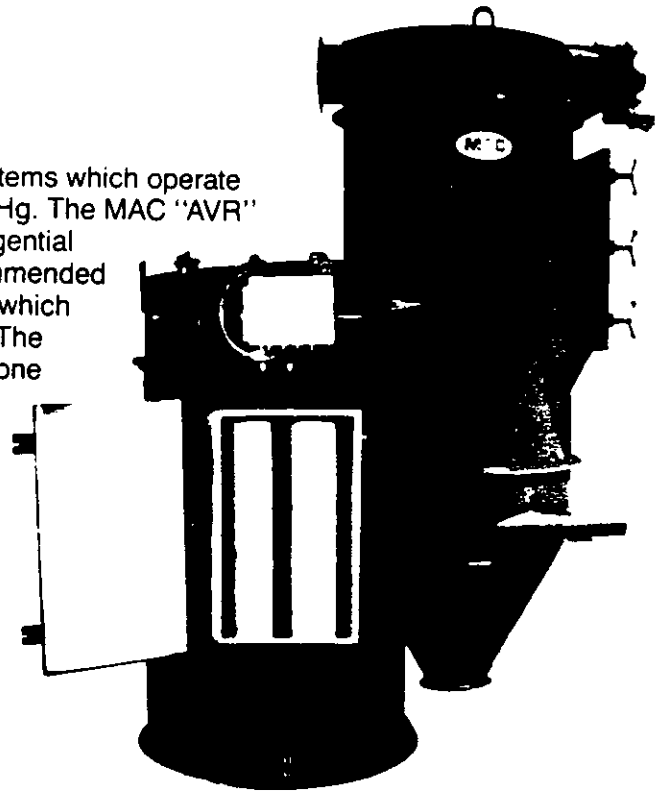

RT, ST, and LST

The "ST", "LST", and "RT" models are similar to the "AVS" and "AVR" models but are designed for top bag removal. All have clean air plenums with hinged top doors for easy bag removal. The larger "RPT" models (not illustrated) are available with walk-in plenums.

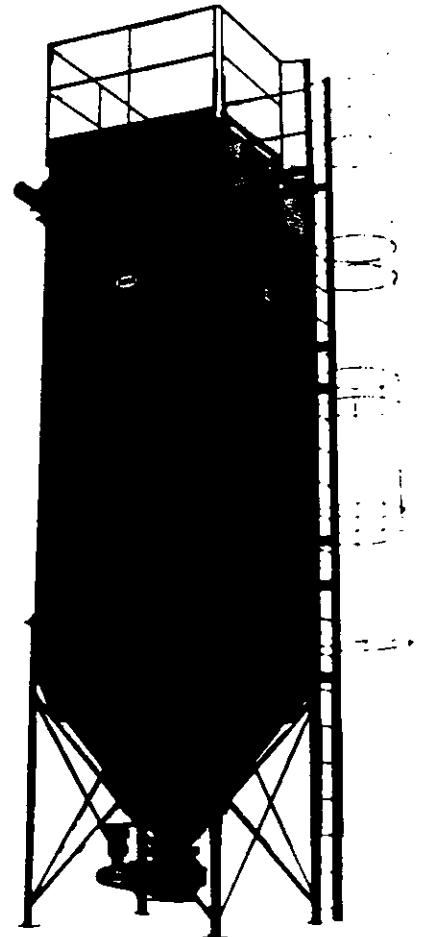
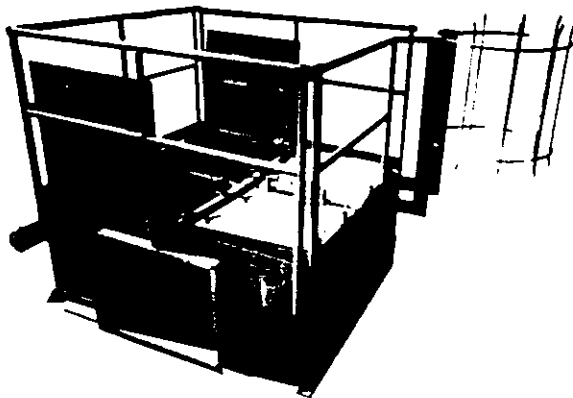

Features

Diaphragm Valves

Furnished in ¾" and 1½" sizes. Designed for maximum shock wave cleaning.

Header

Provides surge capacity for the compressed air system.

Magnehelic Gauge

Monitors differential pressure across the filter bags allowing for an easy method of determining the operating condition.

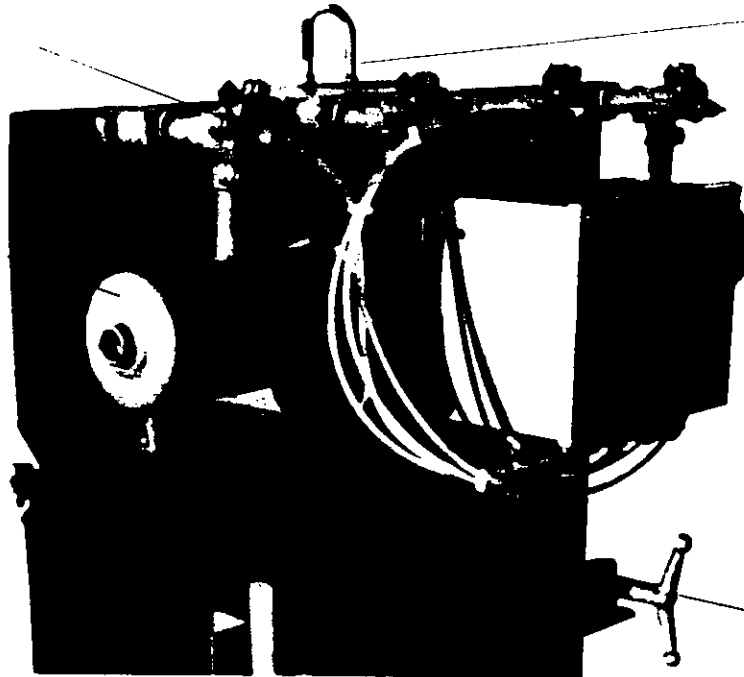

Lifting lugs

shop installed.

Timer Board

Reliable printed circuit board which provides the sequencing for cleaning the dust laden filter bags with compressed air. Features adjustable settings for increasing or decreasing the frequency or duration of the pulse.

Hinged Door with Captive Handles

Factory assembly and pre-wire—Factory wiring of the timer and solenoid valves minimizes installation cost and insures proper hook-up.

Options



Hi Entry Inlet

Used in air pollution control systems for light dust particles. The baffled hi entry inlet allows light dust particles to settle into the hopper without fighting an upward air velocity which would occur with conventional hopper entry inlets.

Pneumatic Receiver Section

Used with "AVR" and "RT" filters in pneumatic conveying systems. Features a tangential entry into the sidewall of the cone and an inner cyclone ring to protect the filter bags against direct wear from abrasive materials and high velocity particles.

Bottom Bag Removal

The AVR and AVS pulse jet filters have bottom cage and bag removal from the interior of the housing. This is economical and convenient for small filter units.

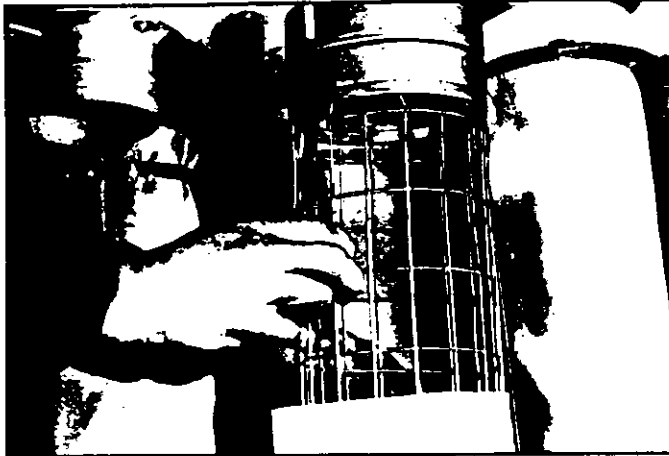

Step 1 The cage is inserted into the full length of the bag.



Step 2 The remainder of the bag is tucked into the cage, being careful not to leave any creases along the rim of the cage.

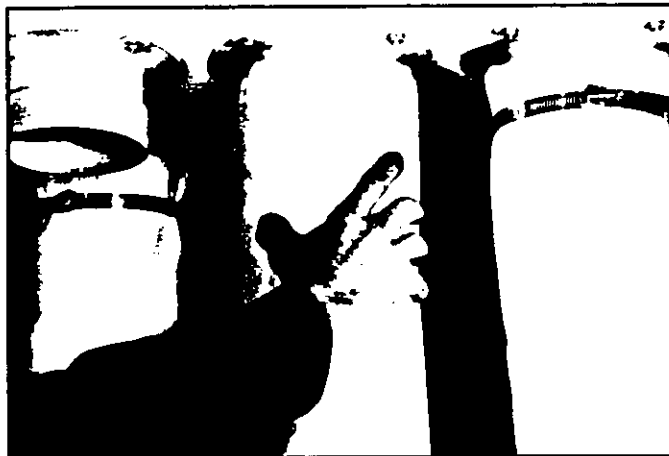

Step 3 The bag and cage are then slid onto the permanently attached bag cup.



Step 4 A positive seal is achieved by used of hose type clamps.

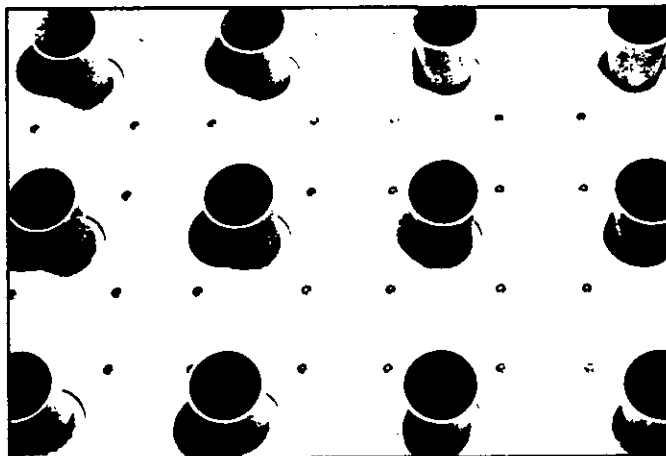

Step 5 The venturies pictured protect the top portion of the bag and assist in improving cleaning efficiency.

Top Bag Removal

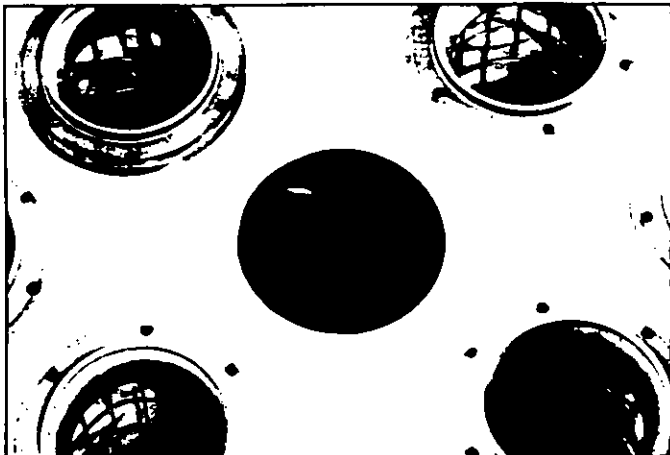

Step 1 Entry into the dirty side of the filter is unnecessary.



Step 2 No tools are required.



Step 3 Snap band with high profile lip seals secure the bag to the tube sheet.

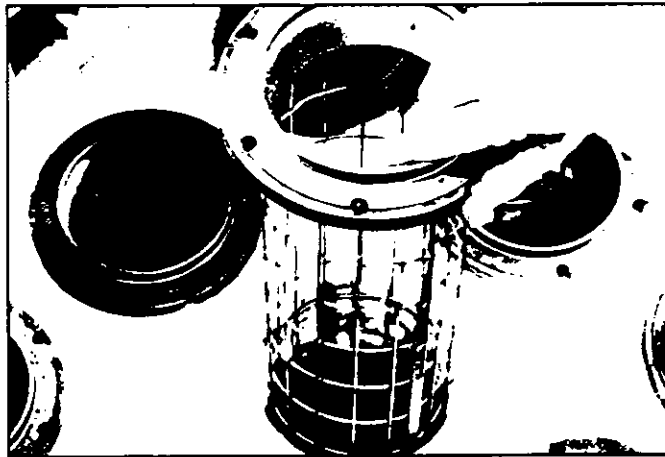

Step 4 The cage snaps into place by merely lowering it into the bag and pushing down.



Step 5 The header pipes are easily installed by sliding the indexed end into the bracket.



Step 6 The header pipes can only fit one way, thus insuring alignment of the blow nozzles.

Specifications and Dimensions

Filter Size	Sq. Ft. Cloth Area	Measurements			
		Housing Sq.	*Overall Ht.	Discharge	
18AVS9 18ST9	22	26	51 53	6	
36AVS9 36ST9	44		69 71		
54AVS9 54ST9	67		87 89		
72AVS9 72ST9	89		105 107		
18AVS16 18ST16	39		34½		61
36AVS16 36ST16	79				79
54AVS16 54ST16	119	97			
72AVS16 72ST16	159	115			
96AVS16 96ST16	209	149 139			
18AVS25 18ST25	62	43 25		67 69	8
36AVS25 36ST25	124	43 25	95 87		
54AVS25 54ST25	186	43 25	103 105		
72AVS25 72ST25	245	43 25	121 123		
96AVS25 96ST25	332	43 25	145 147		
36AVS36 36ST36	179	51½ 36	98 90	10	
54AVS36 54ST36	269	51½ 36	106 108		
72AVS36 72ST36	358	51½ 36	124 126		
96AVS36 96ST36	478	51½ 36	148 150		
36AVS64 54AVS64 72AVS64	318 478 636	68½	103 121 138		
96AVS64 96LST64	850		163 193¾		
120LST64 144LST64	1062 1280		217¾ 241¾		
96LST81 120LST81 144LST81	1069 1345 1620	79	203¼ 227¼ 251¼		
96LST100 120LST100 144LST100	1320 1660 2000		87½	208½ 232½ 256½	
96LST144 120LST144 144LST144	1901 2390 2880			104½	222¾ 246¾ 270¾

Filter Size	Sq. Ft. Cloth Area	Measurements			
		Housing Sq.	*Overall Ht.	Discharge	
18AVR7 18RT7	17	28	56 ⁹ / ₁₆ 55 ¹ / ₄	6	
36AVR7 36RT7	34		74 ⁹ / ₁₆ 73 ¹ / ₄		
54AVR7 54RT7	52		92 ⁹ / ₁₆ 91 ¹ / ₂		
72AVR7 72RT7	69		110 ⁹ / ₁₆ 109 ¹ / ₄		
18AVR14 18RT14	34		40		66 ⁵ / ₈ 65 ¹ / ₂
36AVR14 36RT14	69				84 ⁵ / ₈ 83 ¹ / ₂
54AVR14 54RT14	104	102 ⁵ / ₈ 101 ¹ / ₂			
72AVR14 72RT14	139	120 ⁵ / ₈ 119 ¹ / ₂			
96AVR14 96RT14	185	144 ⁵ / ₈ 143 ¹ / ₂			
36AVR21 36RT21	104	47		90 ⁵ / ₈ 89 ¹ / ₂	5
54AVR21 54RT21	156		108 ⁵ / ₈ 107 ¹ / ₂		
72AVR21 72RT21	209		126 ⁵ / ₈ 125 ¹ / ₂		
96AVR21 96RT21	278		150 ⁵ / ₈ 149 ¹ / ₂		
54AVR32 54RT32	239		60	116 ³ / ₄ 115 ¹ / ₂	
72AVR32 72RT32	318			134 ³ / ₄ 133 ¹ / ₂	
96AVR32 96RT32	425	158 ³ / ₄ 157 ¹ / ₂			
54AVR39 72AVR39	291 388	66		121 ⁵ / ₈ 139 ⁵ / ₈	10
96AVR39 72AVR52	518			163 ⁵ / ₈ 145	
96AVR52 72AVR62	690 617			72 84	
96AVR62 72AVR80	823 797		93	179 ⁹ / ₁₆ 163 ⁵ / ₈	
96AVR80	1062			187 ⁵ / ₈	

*This dimension is a function of the discharge dimension.

AVR and RT Pneumatic Receiver applications —
Height of Receiver Section will vary depending on application and line size.

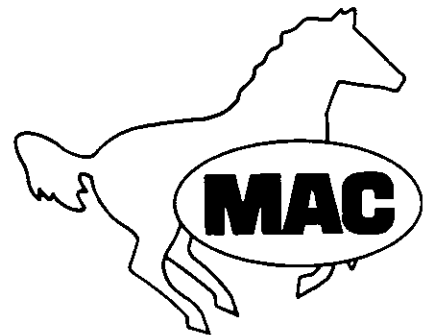

MCF Controlled Fire Filter



The MAC Controlled Fire Filter is the most advanced medium pressure air filter on the market today. The MAC MCF Filters take less horsepower to operate, offer efficient, controlled bag cleaning, require minimal maintenance, and meet the market demand for increased capacities. Patent No. 4,655,799.

Fans

MAC has a complete line of Backward Inclined, High Static, Straight Bladed, and Material Handling Fans for your air handling requirements available in Arrangements 1, 4, and 9.

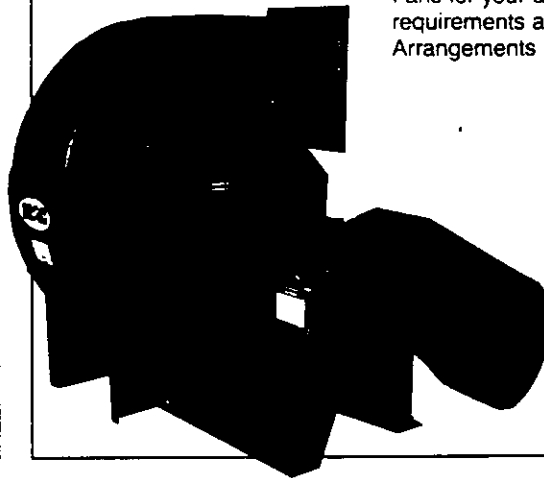

Contact MAC for your complete line of pneumatic conveying systems and components. Ask about our turnkey services available. We also offer MAC Pneumatic Service Center for quick service on new equipment or replacement parts for your pneumatic conveying system.

Airlocks

Pictured is the MAC Heavy Duty Airlock. Our line of Heavy Duty Airlocks are used in a variety of industries.

MAC also manufactures a complete line of High Efficiency Airlocks, No Shear Airlocks, and Light Duty Airlocks for your pneumatic conveying needs plus a complete line of airlock accessories.

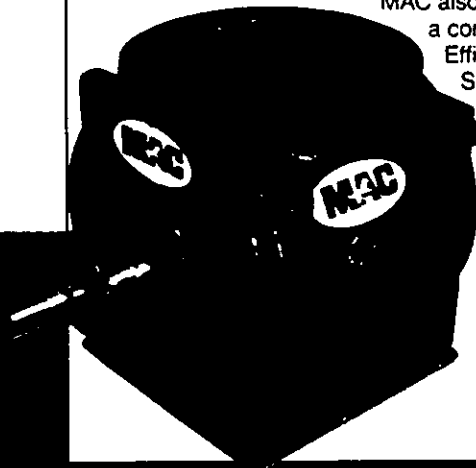

RPT Pulse Jet Filter

MAC also offers large pulse jet filters. Pictured is a large RPT (reverse pulse top bag removal) operated by compressed air. The RPT filter is designed to operate at a pressure or vacuum of up to 20" of water.



Mac Equipment, Inc.

P.O. Box 205
Sabetha, Kansas 66534
Call Toll Free 1-800-223-2191
or In KS Call Collect (913) 284-2191
FAX (913) 284-3565
PJF/6/89

ATTACHMENT C

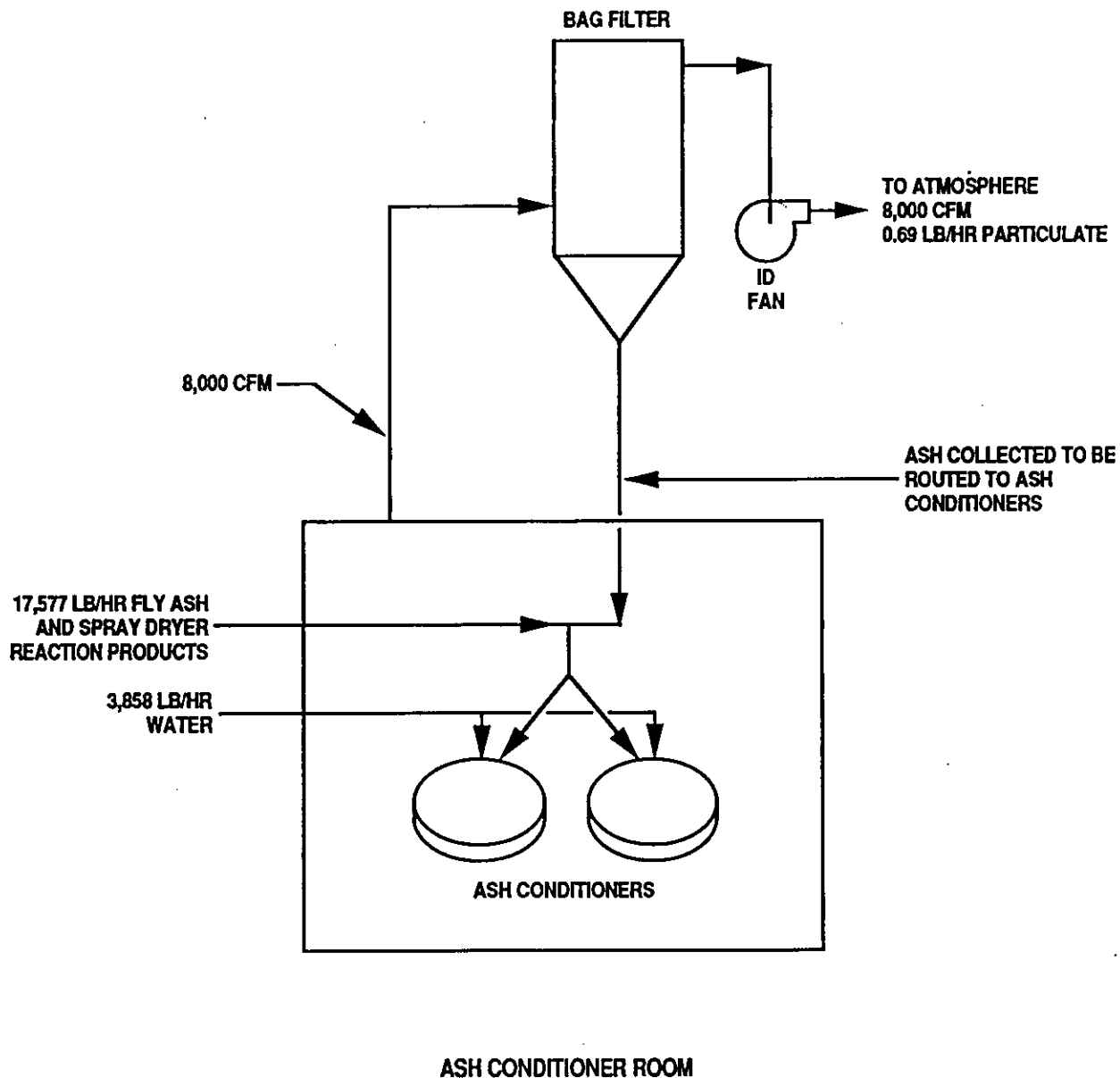

ATTACHMENT C ASH CONDITIONER ROOM
DUST CONTROL FLOW DIAGRAM



ATTACHMENT D

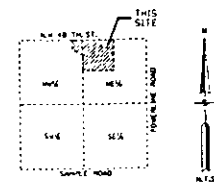
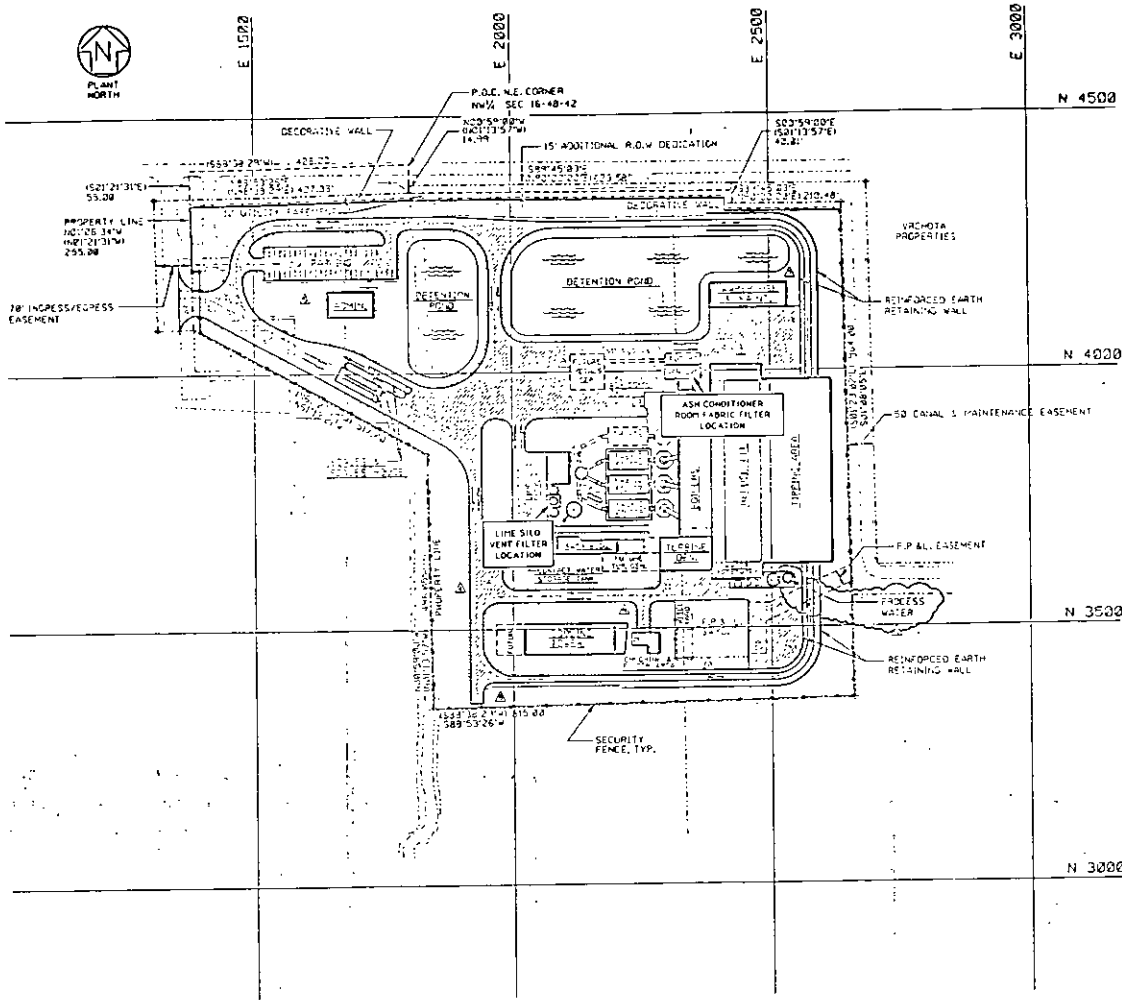

LOCATION MAP

PLOT PLAN LEGEND

- EXISTING FACILITIES
- NEW FACILITIES
- NEW ROADS
- FUTURE FACILITIES

NOTES:

1. FOR GENERAL NOTES AND ABBREVIATIONS SEE DRAWING 01-32-201.
2. PLANT BEARINGS SHOWN IN PARENTHESES (FROM THE PROPERTY BOUNDARY) ARE BASED ON WASTE MANAGEMENT INC. PLAT NO. 2-A, SHEET 1 OF 2 AND SHEET 2 OF 2, PLAT BOOK 139 - PAGE 14, BROWARD COUNTY RECORDS; PREPARED BY KEITH & SCHMARS, P.A., SURVEYORS & CERTIFICATE DATED 2/4/88. OTHER BEARINGS AND ALL COORDINATES SHOWN ARE BASED ON PLANT NORTH WHICH IS ROTATED 201°57' CLOCKWISE FROM PLAT BEARINGS.

- © Bill Stegall 3-16-90
- © Bill Stegall 12-27-89
- © Bill Stegall 10-25-89
- ▲ W.A. RUTHERFORD 09-18-89
- ▲ W.A. RUTHERFORD 02-23-89

RELEASED FOR CONSTRUCTION
BY RE.McCALL DATE 05-21-89

WHEELABRATOR ENVIRONMENTAL SYSTEMS INC.
Dunwoody, Georgia

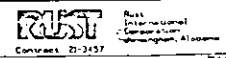

PLOT PLAN
NORTH BROWARD RESOURCE RECOVERY FACILITY
Drawing Number 01-32-200 6

NO.	DATE	DESCRIPTION	BY	CHECKED
1	01-32-200	ISSUED FOR CONSTRUCTION	RE.McCALL	
2	05-21-89	RELEASED FOR CONSTRUCTION	RE.McCALL	
3	02-23-89	REVISED	W.A. RUTHERFORD	
4	09-18-89	REVISED	W.A. RUTHERFORD	
5	10-25-89	REVISED	BILL STEGALL	
6	12-27-89	REVISED	BILL STEGALL	
7	3-16-90	REVISED	BILL STEGALL	

01-32-200
4-6-89

SCALE	1/4" = 1'-0"	DATE
DATE		
SCALE		