

PPM

**COMPLIANCE ASSURANCE
MONITORING PLAN
MOTIVA ENTERPRISES LLC
SOUTH TERMINAL
FDEP FACILITY ID 0110050
FORT LAUDERDALE, FL**

**MOTIVA ENTERPRISES LLC
1200 SE 28TH STREET
FORT LAUDERDALE, FLORIDA**

PPM PROJECT NO. 550302

SEPTEMBER 2003

PPM Consultants, Inc.



PPM CONSULTANTS, INC.

11832 NEWCASTLE AVENUE · SUITE 11 · BATON ROUGE, LA 70816 · 225.293.7270 · fax 225.293.7271

September 22, 2003

Department of Natural Resource Protection
Attn: Seree Jairam
Air Quality Division
218 S.W. 1st Avenue
Fort Lauderdale, FL 33301

RECEIVED
SEP 23 2003
BUREAU OF AIR REGULATION

Re: Compliance Assurance Monitoring Plan
Port Everglades South Terminal
Permit Nurnber 0110050-001-AV
PPM Project No. 550302

TRANSMITTAL LETTER

Dear Mr. Jairam:

On behalf of Motiva Enterprises, LLC we are submitting an original of the referenced Compliance Assurance Monitoring Plan for the Port Everglades South Terminal facility located in Fort Lauderdale, Florida.

Should you have any questions or concerns, please feel free to contact me or Cindy Thompson at (225) 293-7270.

Sincerely,

Heather Lechtenberg
Environmental Specialist

Enclosures as stated

cc:

Jonathan Holthom
Division of Air Resource Management
2600 Blair Stone Road
M.S. 5505
Tallahassee, FL 32399-2400

RECEIVED

SEP 23 2003

BUREAU OF AIR REGULATION

**COMPLIANCE ASSURANCE
MONITORING PLAN
MOTIVA ENTERPRISES LLC
SOUTH TERMINAL
FDEP FACILITY ID 0110050
FORT LAUDERDALE, FL**

**MOTIVA ENTERPRISES LLC
1200 SE 28TH STREET
FORT LAUDERDALE, FLORIDA**

PPM PROJECT NO. 550302

SEPTEMBER 2003

TABLE OF CONTENTS

	<u>PAGE</u>
EXECUTIVE SUMMARY-COMPLIANCE ASSURANCE MONITORING PLAN	iii
EXECUTIVE SUMMARY-TEST RESULTS	vi
1.0 COMPLIANCE ASSURANCE MONITORING – RATIONALE AND JUSTIFICATION	1
1.1 Background	1
1.1.1 Pollutant-Specific Emissions Unit	2
1.2 Rationale for Selection of Performance Indicators	2
1.3 Rationale for Selection of Indicator Ranges	3
1.3.1 Compliance Indicator No.1 – Monitoring Vacuum Profile of VRU	3
1.3.1.1 Action Level	3
1.3.1.2 Excursion Level/Reportable Incident Level	4
1.3.2 Compliance Indicator No. 2 – Inspection, Maintenance, Operator Training and Biennial Carbon Bed Testing	4
1.3.2.1 Reportable Incident Level	4
1.3.3 Compliance Indicator No. 3 – Monthly Leak Detection and Repair Program	4
1.3.3.1 Action Level	5
1.3.3.2 Reportable Incident Level	5
1.4 Response to Compliance Indicators	5
1.4.1 Compliance Indicator No. 1-Monitoring Vacuum Profile Of VRU	5
1.4.1.1 Action Level	5
1.4.1.2 Excursion Level/Reportable Incident Level	5
1.4.2 Compliance Indicator No. 2-Inspection, Maintenance, Operator Training and Biennial Carbon Bed Testing	6
1.4.2.1 Action Level	6
1.4.2.2 Incident Level	6
1.4.3 Compliance Indicator No. 3-Monthly Leak Detection and Repair Program	6
1.4.3.1 Action Level	6
1.4.3.2 Incident Level	6
1.5 Air Pollution Control Device Bypass Monitoring	6
1.6 Implementation Plan and Schedule	6

TABLE OF CONTENTS (continued)

APPENDICES

- Appendix A CAM Plan Approach Criteria
- Appendix B VRU Daily Operation Log
- Appendix C VRU Weekly Inspection Report
- Appendix D Monthly VRU Malfunction Report
- Appendix E Quarterly Preventative Maintenance Checklist, Operator Training Documentation, Annual Carbon Bed Testing
- Appendix F Monthly Leak Inspection Form
- Appendix G Engineering Emission Analysis Test Results

EXECUTIVE SUMMARY – COMPLIANCE ASSURANCE MONITORING PLAN

Motiva Enterprises, LLC (Motiva) owns and operates a petroleum bulk terminal on 1200 SE 28th Street, Fort Lauderdale, Florida. This facility is known as the South Terminal. The South Terminal is a major source for Volatile Organic Compounds (VOCs) and was issued a Title V Operating permit by the Broward County Department of Planning and Environmental Protection (DPEP). The pollutant-specific emissions unit (PSEU) of concern at Motiva is classified as an "Other PSEU" per 40 CFR 64.5(b). Facilities with "other PSEUs" are required to submit a Compliance Assurance Monitoring (CAM) plan with the Title V renewal application. Motiva submitted a Title V renewal application to DPEP in January 2003; this document constitutes the CAM plan.

The Motiva North Terminal located near the South Terminal, in Fort Lauderdale, Florida also has a carbon adsorption vapor recovery unit (VRU). These two terminals will operate their VRU compliance assurance monitoring in the same manner. The only difference in the VRU's at these two terminals is that the North Terminal has a bladder tank for the back-up device and the South Terminal has a back-up Vapor Combustion Unit (VCU). This CAM plan addresses the South Terminal, which has a dual-bed vacuum regenerative carbon adsorption vapor recovery unit (VRU) and a back-up VCU. The VRU is used to reduce VOC emissions during the loading of petroleum products into trucks. The VRU is currently permitted as Emissions Unit ID No. 001, in the facility's Title V permit (Permit No. 0110050-001-AV). VOC vapors from the loading rack go through the VRU to be controlled. Should the VRU shutdown, the VCU will be used to control the emissions on the rack. The loading rack's vapor collection system (and subsequently the VRU) is subject to an emission limitation standard that restricts emissions to 35 mg of total organic compounds per liter of gasoline loaded, under 40 CFR 60.502(b).

The monitoring approach described in this CAM plan relies on presumptively acceptable monitoring as allowed under 40 CFR 64.4(b). The guidance used for the proposed monitoring is "USEPA CAM Technical Guidance Document, A.24 Carbon Adsorber for VOC Control - Facility EE," dated September 2000. Based on the USEPA guidance document and tests conducted at the facility, three compliance indicators have been selected to monitor the performance of the VRU. These indicators are discussed below. It should be noted that an existing system that monitors some of the indicators partially, is already in place and in operation. However, not all compliance indicators are currently being monitored.

This document is organized as follows: the section titled "Compliance Assurance Monitoring Rationale and Justification" includes a detailed background, discusses each compliance indicator in detail and the rationales for selecting such indicators, monitoring frequencies, and action and excursion levels triggering various operator responses. **Appendix A** contains the CAM plan approach criteria in a tabular format, and is based on the table in the EPA guidance document. Appendices B through F contain samples of operator logs, inspection forms, and maintenance and malfunction reports that the facility maintains/will maintain. **Appendix G** contains copies of results of tests conducted in February 2003, and February and March 2003.

According to the convention followed at the facility, and therefore in this CAM plan, a greater vacuum refers to a value closer towards absolute vacuum, whereas less vacuum refers to a value closer towards atmospheric pressure. Thus a vacuum greater than (or above) 25.5 inches of mercury vacuum. Hg vacuum indicates a vacuum closer toward absolute vacuum.

Compliance Indicators

Monitoring Vacuum Profile of VRU

Engineering emission testing on the North Terminal VRU, which is the representative of the South Terminal VRU, performed during normal loading conditions in February and March 2003 demonstrated that if the regenerating carbon bed stays at or above 25.5 in. Hg vacuum, the bed is properly regenerated and will have the capacity to meet the permit-specified VOC emission limits under all loading conditions. Hence this plan proposes to monitor the vacuum on the regenerating bed continuously to confirm that it remains at or above 25.5 in. Hg vacuum during each regeneration cycle. Failure to maintain the regenerating bed at or above 25.5 in. Hg vacuum during a regeneration cycle may cause an excursion. If such an event should occur, vapors from the loading rack will be routed to the VCU until the VRU regenerating bed reaches a vacuum of 25.5 in. Hg vacuum – either via operator/maintenance intervention or through continued regeneration. In the event the VRU does not reach its designated vacuum level of 25.5 in. Hg and the VCU shutdowns, an automatic alarm is triggered wherein the loading rack is shut down and no further loading operations can take place until corrective actions are taken. An excursion will trigger an investigation, corrective action, and an external (agency) reporting requirement. However such reporting may not necessarily be indicative of an emission of non-methanogenic organic carbon (NMOC) above permitted levels. True

As a backup mechanism that may warn operators of a potential impending excursion level vacuum, Motiva proposes to install a visual alarm that will be triggered when the regenerating bed decreases to 26.5 in. Hg vacuum. The visual alarm can be turned off only via operator intervention and thus may allow internal corrective action to be taken even before a potential excursion can occur.

26.5 = Excursion
25.5 = Excursion?

Inspection, Maintenance, Operator Training and Biennial Carbon Bed Testing

An inspection, maintenance and operator training program will be implemented and documented by Motiva. Biennial testing of carbon in carbon beds will also be performed. The terminal operator on duty currently performs VRU operational checks each day during normal working days. Biennial carbon bed testing and quarterly maintenance is performed by a contracted maintenance company. An external reportable incident (although not necessarily indicative of an emission of NMOC above permitted levels) occurs if the periodic inspections, scheduled maintenance, or carbon bed tests are not performed or documented, or if corrective actions are not initiated within 24 hours of detection of problems.

Monthly Leak Detection and Repair Program

A monthly leak detection and repair program of the vapor recovery system will be implemented. The vapor recovery system will be inspected for leaks using sight, sound, smell and a handheld

Lower Explosive Limit (LEL) monitor per 40 CFR 60.502(j). A reportable incident (although not necessarily indicative of an emission of NMOC above permitted levels) is defined as a detection of a leak greater than or equal to 20% of the LEL during normal loading operations. A reportable incident will trigger an investigation, corrective action and an external reporting requirement. Leaks will be repaired within 15 calendar days.

Justification for Monitoring Approach, Selection of Indicators and Indicator Range

Tests conducted on the North Terminal VRU in February 2002, February 2003, and March 2003, and the USEPA CAM guidance document were the bases for the proposed monitoring approach, selection of the above compliance indicators and their ranges.

EXECUTIVE SUMMARY – TEST RESULTS

Three tests were conducted on the North Terminal VRU, which is representative of the South Terminal VRU, during the period February 2002 through March 2003. Results of these tests are summarized below.

Performance Test, February 2002

This test showed VOC emissions of 1.33 mg/l of product loaded. Comparing the mass of VOC flowing into the VRU with the mass of VOC flowing out, the removal efficiency is calculated as 99.89%. The actual (test) emissions represent 3.8% of the allowable emissions limit of 35 mg/l.

Engineering Emission Test Analysis, February 2003

This test showed VOC emissions of 8.77 mg/l and a VOC removal efficiency of 99.27%, with a vacuum of 25.5 in. Hg. At a vacuum of 26.5 in. Hg, the VOC emissions were 1.08 mg/l and the VOC removal efficiency was 99.92%. The test emissions of 8.77 and 1.08 mg/l represent 25.1% and 3.1% respectively, of the allowable emissions limit. The testing demonstrated that if the regenerating carbon bed stays above or at 25.5 in. Hg vacuum the bed will be properly regenerated and will have the capacity to meet the VOC emissions limit under all loading conditions

Continuous Emission Monitoring (CEM) Test Analysis, March 2003

The CEM testing performed continuously over a duration of 24 hours showed that at a vacuum of 25.5 in. of Hg, VOC mass removal efficiency was 99.95%. This data demonstrates that the carbon adsorber is operating well below the VOC emission limit and that the current preventative maintenance (PM) and operational program for the VRU is maintaining the VRU in an excellent working condition. This test confirmed that at a vacuum of 25.5 in. of Hg, the regenerating bed regenerates adequately and that VOC emissions are well below the emission limits.

Appendix G contains a copy of the test results.

1.0 COMPLIANCE ASSURANCE MONITORING – RATIONALE AND JUSTIFICATION

1.1 BACKGROUND

The pollutant-specific emissions unit (PSEU) at the Motiva South Terminal is subject to compliance assurance monitoring (CAM) requirements under 40 CFR Part 64 due to the following reasons:

- it is located at a major source that is required to obtain a Title V permit;
- it is subject to an emission limitation of 35 mg of Total Organic Carbon per liter of gasoline loaded, as specified in 40 CFR 60.502(b);
- it uses a control device to achieve compliance with the above emission limit;
- its potential pre-control emissions of volatile organic compounds (VOCs) from the PSEU are at least 100 tons per year (which is the major source threshold for Broward County); and
- it is not otherwise exempt from 40 CFR Part 64.

The monitoring approach described in this CAM plan relies on presumptively acceptable monitoring identified in guidance from EPA and is therefore consistent with the requirements of 40 CFR 64.4(b). Specifically, 40 CFR 64.4(b)(5) allows the use of presumptively acceptable monitoring identified in guidance from the EPA. The guidance used for the proposed monitoring is "USEPA CAM Technical Guidance Document, A.24 Carbon Adsorber for VOC Control - Facility EE," dated September 2000. Where the facility varies from presumptively acceptable monitoring, the facility proposes to use monitoring recommended by the manufacturer and valid engineering assessments and test data, consistent with 40 CFR 64.4(c)(1).

The Motiva North Terminal is located near the South Terminal in Fort Lauderdale, Florida. The Motiva North Terminal also has a carbon adsorption vapor recovery unit (VRU). These two terminals will operate their VRU compliance assurance monitoring in the same manner. The only difference in the VRU's at these two terminals is that the North Terminal has a bladder tank for the back-up device, the South Terminal has a back-up Vapor Combustion Unit (VCU). This CAM plan addresses the South Terminal, which has a dual-bed vacuum regenerative carbon adsorption vapor recovery unit (VRU) and a back-up VCU. The VRU is used to reduce VOC emissions during the loading of petroleum products into trucks. The VRU is currently permitted as Emissions Unit ID No. 001, in the facility's Title V permit (Permit No. 0110050-001-AV). VOC vapors from the loading rack go through the VRU to be controlled. Should the VRU shutdown, the VCU will be used to control the emissions on the rack. The loading rack's vapor collection system (and subsequently the VRU) is subject to an emission limitation standard that restricts emissions to 35 mg of total organic compounds per liter of gasoline loaded, under 40 CFR 60.502(b).

1.1.1 Pollutant-Specific Emissions Unit

The PSEU addressed in this CAM plan is a vacuum regenerative carbon absorber and a backup vapor combustion unit used to reduce VOC emissions from the loading of petroleum products into trucks at the Motiva South Terminal. The Motiva North Terminal and Motiva South Terminal VRUs are operated in the same manner. The petroleum products loaded are gasoline, diesel and additives. The PSEU is a McGill[®] carbon vapor recovery unit (VRU). The carbon adsorber has two identical beds, one adsorbing while the other is desorbing, with each bed on a 15-minute cycle. Carbon bed regeneration is accomplished by a combination of high vacuum and purge air stripping, which removes previously adsorbed petroleum vapor from the carbon and restores the carbon's ability to adsorb vapor during the next cycle. The vacuum pump extracts concentrated petroleum vapor from the carbon bed and discharges into a separator. Non-condensed hydrocarbon vapor and hydrocarbon condensate flow from the separator to an absorber column, which functions as the recovery device for the system. In the absorber, the hydrocarbon vapor flows up through the absorber packing, where it gets liquefied and is subsequently recovered by absorption. Gasoline product from a storage tank is used as the absorbent fluid. The recovered product is returned along with the circulating gasoline back to the product storage tank. A small stream of air and residual vapor exits the top of the absorber column and is recycled to the on-stream carbon bed where the residual petroleum vapor is re-adsorbed.

Four loading bays are equipped to load petroleum products onto trucks. Each bay is equipped with vapor recovery hoses positioned at the truck loading areas for hook-up to the vapor control system. The vapor hoses and associated piping transport vapors to the VRU. The VRU has a backup vapor combustion unit that can control VOC emission should the VRU shutdown. **Appendix A** contains key elements of the CAM plan approach criteria in a tabular format, and is based on the table in the EPA guidance document.

1.2 RATIONALE FOR SELECTION OF PERFORMANCE INDICATORS

The carbon adsorption system was designed and engineered specifically for this facility based on the products loaded and the maximum expected loading rates. The vacuum profile during regeneration is an important variable in the performance of the VRU. If the carbon bed is overloaded, the time to achieve certain vacuum levels will be longer, and the bed will not be fully regenerated during the 15-minute cycle. The VRU has a backup vapor combustion unit that can control emissions should the VRU carbon beds be overloaded. The verification that the VCU is operating is the presence of a flame. The VCU has a 98% control efficiency of VOCs should the VCU shutdown. Also, when the VCU shuts down an alarm triggers an automatic interlock to the loading system and automatically shuts down the loading rack.

Monitoring of the vacuum profile during regeneration, coupled with regular inspection and maintenance activities, operator training and biennial testing of the carbon sample from each bed, serve to verify that the VRU is operating properly. In addition, a monthly leak inspection program is performed to confirm that the vapors released during loading are captured and conveyed to the VRU. A handheld monitor is used to detect leaks in the vapor collection system.

1.3 RATIONALE FOR SELECTION OF INDICATOR RANGES

1.3.1 Compliance Indicator No. 1 - Monitoring Vacuum Profile of VRU

Compliance Indicator No. 1 will include monitoring the vacuum cycle of the regeneration bed. An engineering emission test analysis was performed on the North Terminal during normal loading conditions in February 2003. The test demonstrated that if the regenerating carbon bed stays at or above 25.5 inches of mercury vacuum (in. Hg vacuum) the bed will be properly regenerated and will have the capacity to meet the VOC emission limits under all loading conditions. This test was followed by a test in March 2003, where a Continuous Emissions Monitoring (CEM) unit was used to monitor emissions for 24 hours; this test confirmed that at a vacuum of 25.5 in. Hg, the regenerating bed regenerates adequately and that VOC emissions are well below the emission limits. **Appendix G** contains a copy of the test results. Based on the test results, an excursion occurs when the regenerating bed decreases to 25.5 in. Hg vacuum. Vacuum readings will be monitored continuously via a pressure transmitter to verify that the regenerating bed remains at or above 25.5 in. Hg vacuum. This excludes periods when the monitoring system is under repair, maintenance, or QA/QC procedures. These vacuum readings will be relayed to the control panel. Operators will observe and record at least one complete regeneration cycle during each 24-hour period during normal working days. When an excursion occurs, vapors are no longer sent to the VRU and a visual alarm is triggered; vapor flow to the VRU does not resume until the VRU regeneration cycle reaches a vacuum of 25.5 in. Hg – either via operator intervention or through self-adjusting means. However, normal loading operations will continue by routing the emissions to the VCU. Should the VCU shutdown then a high level alarm will automatically shutdown the loading rack. **Appendix B** contains the VRU Daily Operation Log, which contains the pressure profile records.

The most recent performance test conducted on the North Terminal VRU in February 2002, showed VOC emissions of 1.33 mg/liter of product loaded. This tested emission value represents 3.8% of the allowable VOC emissions limit of 35 mg/l. The engineering emission test analysis that was performed in February 2003 showed VOC emissions of 8.77 mg/l and a VOC removal efficiency of 99.27%, with a vacuum of 25.5 in. Hg. At a vacuum of 26.5 in. Hg, the VOC emissions were 1.08 mg/l and the VOC removal efficiency was 99.92%. The CEM test that was performed in March 2003, showed that at a vacuum of 25.5 in. Hg, VOC removal efficiency was 99.95%. This data demonstrates that the carbon adsorber is operating well below the VOC emission limit and that the current preventative maintenance (PM) and operational program for the VRU is maintaining the VRU in an excellent working condition.

According to the convention followed at the facility, and therefore in this CAM plan, a greater vacuum refers to a value closer towards absolute vacuum, whereas less vacuum refers to a value closer towards atmospheric pressure. Thus a vacuum greater than (or above) 25.5 in. Hg indicates a vacuum closer toward absolute vacuum.

1.3.1.1 Action Level

In order to provide a high level of assurance that the excursion level is not reached for Compliance Indicator No. 1, the facility proposes an action level set above the excursion level.

The action level will be set at 26.5 in. Hg vacuum. If the vacuum decreases to 26.5 in. Hg during a regeneration bed cycle, a visual alarm is triggered on the control panel, which can be turned off only by operator intervention. Following the acknowledgement of the alarm by an on-duty operator, an investigation and subsequent corrective action(s) will be initiated so that the cause of the problem may be corrected before an excursion occurs.

1.3.1.2 Excursion Level/Reportable Incident Level

As indicated above, an excursion occurs when the regenerating bed decreases to 25.5 in. Hg vacuum. When an excursion occurs, vapors are no longer sent to the VRU and a visual alarm indicating the discontinuation of vapor flow to the VRU is triggered. Under such circumstances, vapors are routed completely to the VCU. Normal loading operations will continue unless the VCU shuts down. At this point the high-level alarm in the holding tank will activate and automatically shut down the loading rack. A reportable incident (although not necessarily indicative of an emission of NMOC above permitted levels) occurs when the vapor flow to the VRU is shut off. Excursion level incidents will be documented in the Monthly VRU Malfunction Report, in **Appendix D**.

1.3.2 Compliance Indicator No. 2 - Inspection, Maintenance, Operator Training and Biennial Carbon Bed Testing

Compliance Indicator No. 2 will include a documented inspection, maintenance and operator-training program, and biennial carbon bed testing. VRU operational checks will be performed each day that an operator is on duty during normal working days. Routine maintenance activities are also conducted. Results of daily inspections and routine maintenance are recorded in the VRU Weekly Inspection Report, included in **Appendix C**. Results of monthly maintenance as well as malfunctions resulting in VRU shut down are recorded in the Monthly VRU Malfunction Report, included in **Appendix D**. Quarterly maintenance and biennial carbon bed testing is performed by a contracted maintenance company. Results of quarterly maintenance activities are recorded and a file copy is maintained onsite. A copy of the quarterly maintenance activities performed is shown in **Appendix E**. Documentation of operator training is also maintained in **Appendix E**.

1.3.2.1 Reportable Incident Level

An external reportable incident (although not necessarily indicative of an emission of NMOC above permitted levels) occurs if the periodic inspections, scheduled maintenance, or biennial carbon bed tests are not performed or documented, or if corrective actions are not initiated within 24 hours of detection of problems.

1.3.3 Compliance Indicator No. 3 – Monthly Leak Detection and Repair Program

Compliance indicator No. 3 will include a monthly leak detection and repair program. The vapor collection and recovery system will be inspected for leaks using sight, sound, smell and a

handheld Lower Explosive Limit (LEL) monitor. Results of the leak inspections are recorded in the Monthly Leak Inspection Form, included in **Appendix F**.

1.3.3.1 Action Level

In order to verify that corrective actions are taken on leaking piping, hoses, etc., before they lead to reportable incidents, Motiva proposes an action level as a detection of a leak greater than or equal to 10% and less than 20% of the LEL during normal loading operations. If a detection of leaks triggering an LEL reading in the action level range occurs, a corrective action will be initiated, the cause of the problem will be identified and repairs will be made within 30 calendar days.

1.3.3.2 Reportable Incident Level

An external reportable incident (although not necessarily indicative of an emission of NMOC above permitted levels) is defined as a detection of a leak greater than or equal to 20% of the LEL during normal loading operations. If a detection of leaks triggering an LEL reading in the reportable level range occurs, a corrective action will be initiated, the cause of the problem will be identified and repairs will be made within 15 calendar days.

1.4 RESPONSE TO COMPLIANCE INDICATORS

The key to demonstrating compliance with permitted emission limits on a long-term basis is the proper operation and maintenance of the PSEU. The above monitoring parameters and indicator ranges were identified to provide verification that the PSEU is operating properly, thereby providing a reasonable assurance of compliance. However, it is equally important that proper action be taken in response to the action and excursion levels of the selected monitoring parameters. These responses are described below.

1.4.1 Compliance Indicator No. 1- Monitoring Vacuum Profile of VRU

1.4.1.1 Action Level

Exceeding the action level range will trigger an investigation, corrective action and an internal reporting requirement. Upon an action level alarm being acknowledged by an operator, a corrective action will be initiated within 24 hours. If onsite personnel cannot conduct the required corrective action, the contracted maintenance group will be notified of the incident within the next 24 hours and will be brought onsite as soon as possible.

1.4.1.2 Excursion Level/Reportable Incident Level

An excursion will trigger an investigation, corrective action, and an external reporting requirement. Upon the discontinuation of the vapor flow to the VRU a visual alarm is triggered and a corrective action will be initiated within 24 hours of acknowledgement of the alarm. If

onsite personnel cannot conduct the required corrective action, the contracted maintenance group will be notified of the incident within 24 hours and will be brought onsite as soon as possible.

1.4.2 Compliance Indicator No. 2- Inspection, Maintenance, Operator Training and Biennial Carbon Bed Testing

1.4.2.1 Action Level

Not applicable.

1.4.2.2 Incident Level

A reportable incident will trigger an investigation, corrective action, and an external reporting requirement. Corrective actions will be initiated within 24 hours of the detection of the reportable incident.

1.4.3 Compliance Indicator No. 3- Monthly Leak Detection and Repair Program

1.4.3.1 Action Level

Exceeding the action level range will trigger an investigation, corrective action and an internal reporting requirement. Leaks will be repaired within 30 calendar days.

1.4.3.2 Incident Level

A reportable incident will trigger an investigation, corrective action and an external reporting requirement. Leaks will be repaired within 15 calendar days.

1.5 AIR POLLUTION CONTROL DEVICE BYPASS MONITORING

Under normal operating conditions, bypass of the VRU cannot occur based on the design of the PSEU. Specifically, all vapors collected at the loading rack flow the VRU. If the vapor flow rate from the loading rack exceeds the processing rate of the VRU, the excess vapors will be routed to the VCU. Should the VCU shutdown, an interlock will automatically shut down the loading rack. The VCU is in compliance as long as a flame is present. There are no other lines coming from the loading rack; thus there are no alternate pathways for vapors to bypass the VRU during normal operation.

1.6 IMPLEMENTATION PLAN AND SCHEDULE

As per 40 CFR 64.4(e), Motiva proposes to install and implement the elements of this proposed CAM plan within 180 days after approval of the Federal Operating Permit. This schedule is contingent upon approval of the CAM plan.

APPENDIX A
CAM PLAN APPROACH CRITERIA

Motiva Enterprises LLC
 Port Everglades, FL South Terminal
 FDEP Facility ID 0110050

Summary Table - Compliance Assurance Monitoring Approach Criteria

	Compliance Indicator 1	Compliance Indicator 2	Compliance Indicator 3
I. Parameter	Regeneration cycle vacuum. Specifically, monitoring the vacuum on the regenerating bed to confirm that it remains at or above 25.5 inches of mercury (in. Hg) vacuum.	Documentation of inspection, maintenance and operator training program and biennial carbon bed testing.	Documentation of inspection, maintenance and leak checks of vapor recovery system.
Measurement Approach	Pressure transmitter, relayed to system PLC.	Proper VRU operation is verified by performing periodic inspections and maintenance by properly trained personnel. Daily operator checks include regenerating bed operating temperature profile, cycle time, operating pressures, operating temperatures, and verification of relevant fluid levels. Daily operator checks are performed each day that an operator is on duty during normal working days. A copy of the VRU Weekly Inspection Report is included in Appendix C. Quarterly maintenance is performed by maintenance contractor. Biennial testing of the carbon in each bed will also be performed. A copy of the quarterly maintenance activities as well as the tests conducted at the North Terminal is included in Appendix E.	Monthly leak check of vapor collection system.
II. Indicator Range Action Level Range*	A corrective action is triggered when the regenerating carbon bed decreases to 26.5 in. Hg vacuum during regeneration. When the action level range is breached, a visual alarm is triggered on the control panel. This alarm must be acknowledged by an operator to turn off.	NA	A corrective action is triggered if an LEL reading of 10% - <20% is detected during an inspection.

Motiva Enterprises LLC
 Port Everglades, FL South Terminal
 FDEP Facility ID 0110050

Summary Table - Compliance Assurance Monitoring Approach Criteria

	Compliance Indicator 1	Compliance Indicator 2	Compliance Indicator 3
Excursion Level/Reportable Incident Range*	An excursion occurs when the regenerating carbon bed decreases to 25.5 in. Hg vacuum during regeneration. A visual alarm is triggered and vapors are no longer sent to the VRU. At this point the high-level alarm will activate and automatically shut down the loading rack. <i>not consistent</i>	A reportable incident (although not necessarily indicative of an emission of NMOC above permitted levels) occurs if the periodic inspections, scheduled preventative maintenance, or biennial carbon test is not performed or documented, or if corrective action is not initiated within 24 hours of detection to correct any problems identified during the inspection, maintenance of the unit or carbon testing.	A reportable incident (although not necessarily an emission of NMOC above permitted levels) occurs if an LEL reading equal to or above 20% is detected during an inspection.
III Response to Indicators Action Level Range	Breach of the action level range will trigger an investigation, corrective action and an internal reporting requirement. Upon an action level alarm being acknowledged by the facility, a corrective action will be initiated within 24 hours. If the required corrective action cannot be conducted by onsite personnel, the contracted maintenance group will be notified of the incident within 24 hours and will be brought onsite as soon as possible. <i>may be</i>	NA <i>no</i>	Exceeding the action level range will trigger an investigation, corrective action and an internal reporting requirement. Leaks will be repaired within 30 calendar days.
Excursion Level/Reportable Incident Range	An excursion will trigger an investigation, corrective action, and an external reporting requirement. It should be noted that such external reporting may not necessarily be indicative of emissions of NMOC above permitted levels. Upon the discontinuation of vapor flow to the VRU, a visual alarm is triggered and a corrective action will be initiated within 24 hours of acknowledgement of the alarm. If the required corrective action cannot be conducted by onsite personnel, the contracted maintenance group will be notified of the incident within 24 hours and will be brought onsite as soon as possible. <i>no</i>	A reportable incident will trigger an investigation, corrective action, and an external reporting requirement. Corrective actions will be initiated within 24 hours of the detection of the reportable incident. <i>no</i>	A reportable incident will trigger an investigation, corrective action and an external reporting requirement. Leaks will be repaired within 15 calendar days.
IV Performance Criteria Data Representativeness	The pressure cycle is measured in the vacuum pump suction line. The minimum accuracy of the pressure transmitter is +/- 1.0 percent. The pressure transmitter is equipped with a visual alarm that is triggered when the regenerating carbon bed vacuum decreases to the Action Level. The alarm has to be acknowledged by an operator to turn off. The pressure transmitter is also equipped with an additional visual alarm that is triggered when the carbon bed vacuum decreases to the excursion level.	VRU operation will be verified by trained personnel using documented inspection and maintenance procedures. Carbon samples will be properly taken using representative samples taken from both beds.	As required by 40 CFR 60.502(j), leaks are inspected using sight, sound and smell and a handheld Lower Explosive Limit monitor.

Motiva Enterprises LLC
 Port Everglades, FL South Terminal
 FDEP Facility ID 0110050

Summary Table - Compliance Assurance Monitoring Approach Criteria

	Compliance Indicator 1	Compliance Indicator 2	Compliance Indicator 3
Verification of Operational Status	NA	NA	NA
QA/QC Practices and Criteria	<p>Pressure transmitter is calibrated annually.</p> <p>Alarm light operation is visually checked each day that an operator is on duty during normal working days.</p> <p>New operators are given 40 hours of hands-on training by a qualified operator, prior to working independently.</p>	<p>New operators are given 40 hours of hands-on training with a qualified operator, prior to working alone.</p> <p>Each operator is given one day of hands-on training annually with the VRU maintenance contractor on proper maintenance, operation and repair of the VRU.</p> <p>Quarterly maintenance is performed by licensed contractor with extensive knowledge of VRU operation and maintenance.</p>	<p>Procedures are followed according to 40 CFR 60.502(j), NSPS for Bulk Gasoline Terminals.</p>
Monitoring Frequency	<p>Pressure profile is monitored and recorded continuously during each regeneration cycle and visual alarms are triggered when the action level/excursion level is breached. Regeneration cycle is monitored visually, once per 24 hour shift when operator is on duty during normal working days.</p> <p>Alarm light is checked daily when operator is on duty.</p>	<p>Periodic operation and maintenance checks conducted by onsite trained operators.</p> <p>Contract maintenance group performs quarterly scheduled maintenance. Carbon bed testing is performed biennial.</p>	<p>Monthly leak check of vapor collection system. A copy of the monthly leak inspection form is included in Appendix F.</p>
V. Data Collection Procedures	<p>The operator records the pressure profile during one regeneration cycle per 24 hour shift, except when operator is not on duty (weekends, holidays, etc.) Copies of these pressure profile records are maintained in Appendix B. Alarm light and status are checked and recorded once per day except when operator is not on duty (i.e., weekends, holidays). Alarm lights will not turn off until acknowledged. After the period when an operator is not on duty, the first shift operator on duty will initiate VRU operation inspection as soon as possible after beginning shift. Excursion level alarm triggers shutdown of vapor flow to VRU. Periods of system shut down on the loading racks are recorded in Appendix D.</p>	<p>Results of daily inspections are recorded in the VRU Weekly Inspection Report. Incidents when the VRU is taken out of service for routine maintenance by plant personnel are recorded in a Monthly Maintenance and Malfunction Report. A copy of this report is included in Appendix D. Quarterly maintenance report is prepared by the maintenance service company and a copy is left at the terminal prior to their departure. Results of the biennial carbon bed testing are maintained onsite. Documentation of operator training along with the quarterly maintenance report and carbon bed test results are maintained in Appendix E.</p>	<p>Records of leak checks, leaks found, and corrective actions taken are kept on file at the facility.</p>
Averaging Period	None.	None.	None.

Motiva Enterprises LLC
Port Everglades, FL South Terminal
FDEP Facility ID 0110050

Summary Table - Compliance Assurance Monitoring Approach Criteria

	Compliance Indicator 1	Compliance Indicator 2	Compliance Indicator 3
APCD Bypass Monitoring	Under normal operating conditions, bypass of the APCD (i.e., the VRU) cannot occur based on the design of the PSEU. Specifically, all vapors collected at the loading rack are routed to the VRU. If the VRU shuts down, the excess vapors will be controlled by the VCU. Should the VCU become unoperational then an interlock will automatically shut down the loading rack.		

* Indicator ranges for Compliance Indicator No. 1 were developed by conducting engineering emission test analyses in February and March 2003 at the North Terminal, which is representative of the South Terminal VRU operations.

APPENDIX B
VRU DAILY OPERATION LOG

Appendix B
Motiva Enterprises LLC
Port Everglades, FL South Terminal
FDEP Facility ID 0110050
VRU Daily Operation Log - McGill© Vapor Recovery Unit

Monitor adsorber temperatures and vacuum levels during one regeneration cycle per 24-hour day, during normal working days.
 Indicate with (*) when purge air trips SV101 or SV102.
 Normal bed temperatures, 20-200 F.

Date: _____ Operator Name: _____

V-1 Regeneration

Start Temperatures (F): TI101: _____
 TI102: _____
 TI103: _____

V-2 Regeneration

TI101: _____
 TI102: _____
 TI103: _____

Regeneration Time (minutes)	Vacuum, inches Hg.	
	PI101 (V-1)	PI501 (C-1)
0	_____	_____
1	_____	_____
2	_____	_____
4	_____	_____
6	_____	_____
8	_____	_____
10	_____	_____
12	_____	_____
14	_____	_____
15	_____	_____
16	_____	_____

Vacuum, inches Hg.	
PI201 (V-2)	PI501 (C-1)
_____	_____
_____	_____
_____	_____
_____	_____
_____	_____
_____	_____
_____	_____
_____	_____
_____	_____
_____	_____
_____	_____
_____	_____

End Temperatures (F): TI101: _____
 TI102: _____
 TI103: _____

TI101: _____
 TI102: _____
 TI103: _____

APPENDIX C
VRU WEEKLY INSPECTION REPORT

Appendix C
Motiva Enterprises LLC
Port Everglades, FL South Terminal
FDEP Facility ID 0110050
VRU Weekly Inspection Report - McGill© Vapor Recovery Unit

		MON	TUE	WED	THU	FRI	SAT/SUN
	DATE:						
Gasoline Supply Pressure	PI701						
Gasoline Return Pressure	PI601						
Temp. Gasoline Supply	TI701						
Gas. to Absorber Pressure	PI301						
Gasoline Return Pressure	PI302						
Gas. Level in Separator	LG302						
Temp. Heat Exchanger Out	TI303						
Temp. Gasoline in Separator	TI302						
Temp. Glycol in Separator	TI301						
Temp. Seal Fluid Inlet	TI401						
Temp. Vacuum Pump Inlet	TI402						
Glycol Level in Separator	LG301						
Seal Fluid Inlet Pressure	PI402						
Vacuum on Pump Gauge	PI401						
Fluid Leaks (Remarks*)							
Abnormal Noises (Remarks*)							
General System Alarm Check							
Bed Pressure Visual Alarm Check for 26.5 in. Hg Vacuum (Off/On)							
Bed Pressure Visual Alarm Check for 25.5 in. Hg Vacuum (Off/On)							
Oil Level/Supply Pump							
Oil Level/Return Pump							
Bladder Tank Level							
Bladder Tank Isolation Valve (Open/Close)							
Vacuum Pump Change to #							
Supply Strainer Last Cleaned:							
Vacuum Pumps and Motors Last Lubed:							
Glycol Last Added:							

APPENDIX D
MONTHLY VRU MALFUNCTION REPORT

MONTH

MALFUNCTION REPORT

PLANT

OUT-OF-SERVICE DATE/TIME	RET'D TO SERVICE DATE/TIME	TIME OUT OF SERVICE	SIGNED BY	DESCRIBE MALFUNCTION	GOVERNMENT AGENCY AND PERSON NOTIFIED
DID MALFUNCTION RESULT IN EMISSIONS THAT REQUIRED REPORTING TO A GOVERNMENTAL AGENCY? () NO () YES		ELECTIVE () NON ELECTIVE ()			
DID MALFUNCTION RESULT IN EMISSIONS THAT REQUIRED REPORTING TO A GOVERNMENTAL AGENCY? () NO () YES		ELECTIVE () NON ELECTIVE ()			
DID MALFUNCTION RESULT IN EMISSIONS THAT REQUIRED REPORTING TO A GOVERNMENTAL AGENCY? () NO () YES		ELECTIVE () NON ELECTIVE ()			
DID MALFUNCTION RESULT IN EMISSIONS THAT REQUIRED REPORTING TO A GOVERNMENTAL AGENCY? () NO () YES		ELECTIVE () NON ELECTIVE ()			

ELECTIVE MEANS YOU CHOSE TO TAKE THE UNIT OUT OF SERVICE, NON ELECTIVE MEANS YOU HAD TO TAKE THE UNIT OUT OF SERVICE
 *SYSTEM INCLUDES VAPOR PROCESSING UNIT, VENTS (INCLUDING TANKS IF CONNECTED), VAPOR HOLDER, VAPOR PIPING, T/T BACK LOADING ASSEMBLIES AND VAPOR HOSES. REPORT ALL INCIDENTS RESULTING IN EMISSIONS REQUIRING NOTIFICATION TO AN AGENCY ANY MAJOR EQUIPMENT/COMPONENT FAILURE AND ALL EQUIPMENT FAILURES/PROBLEMS OF A REPETITIVE NATURE.

08/13/2003 10:48 9547633567

MOTIVA NORTH

APPENDIX E

**QUARTERLY PREVENTATIVE MAINTENANCE CHECKLIST,
OPERATOR TRAINING DOCUMENTATION, ANNUAL CARBON BED TESTING**

QUARTERLY PREVENTATIVE MAINTENANCE CHECKLIST



JORDAN TECHNOLOGIES, INC.

P.O. Box 118 Fisherville, Kentucky 40023
Ph: (502) 267-8344 Fax: (502) 267-8379

Page 2 of 2

Job # _____

LABOR PERFORMED & REMARKS CONTINUED:

6. Replaced both Vacuum Gauges on Carbon bed inlet lines, due to gauges being out of calibration showing 2" Hg on (V2) and 3 1/2" Hg (V1) out of adjustment
7. Glycol G.P.M. on arrival @ 23:00pm, found strainer very dirty and cleaned up. (strainer cleaned 2 wks earlier by operator at terminal).

* Recommend Glycol be drained down and flushed out, if strainer and GPMs continue to change.

GPM's Set at '30' as per ~~per~~ specifications in Book.

8. Replaced Glycol Sight Glass.

9. Terminal notified of all work performed.

8. ADDITIONAL PARTS & EQUIPMENT

Qty	Item Number	Description

Customer Signature: A.E. House Printed Name: A.E. House Date: 06/12/03 Cust. PO Number: _____

JORDAN SERVICE COMPANY

(M)

(76CA)

PREVENTATIVE MAINTENANCE CHECK LIST

Truck 19

TERMINAL NAME: Motiva South

ADDRESS: 1200

Fort Lauderdale, Fl.

SERVICE TECHNICIAN: Andy Zurro

DATE THIS INSPECTION: 1-23-02

ARRIVAL TIME: 0800 DEPARTURE TIME: 0

**TERMINAL WAS NOTIFIED PRIOR TO THIS SCHEDULED INSPECTION AND ALL PROBLEMS WERE DISCUSSED WITH TERMINAL MANAGER BEFORE INSPECTION STARTED.

COMMENTS: _____

CUSTOMER SIGNATURE: _____

OPERATING SET POINTS
FROM THE MCGILL BOOK

		BOOK	FIELD
1.	Pressure Drop Across FE-1	<u>56</u>	<u>56</u>
2.	PI-3B Absorber Pressure	<u>14.2</u>	<u>14.2</u>
3.	Purge air pressure switch	<u>28.5</u>	<u>28.5 (Plc)</u>
4.	Minimum flow pressure switch	<u>29.5</u>	<u>29.5</u>
5.	Improper regeneration switch		
		Bed A	<u>25</u>
6.	FI-FSL-1A. Glycol flow rate	<u>30</u>	<u>30</u>
7.	TR-1 Cycle time	<u>15</u>	<u>Plc (15)</u>
8.	TR-2 Equalization time	<u>2</u>	<u>1.5 (Plc)</u>
9.	Purge air oil heater temperature	<u>-</u>	<u>-</u>

ANNUAL CHECK #1

1. Check Carbon levels.
2. Grease all pumps and motors.
3. Pull and inspect Brooks float assembly. Rebuild if needed.
4. Check alignment of vacuum pump with dial indicator.
5. Change purge oil.
6. Pull and calibrate carbon bed thermometers.
7. Check and record Amp draws and Meg Ohm readings on (A) Pump Motors.

SEMI ANNUAL CHECK #2

1. Grease all pumps and motors.
2. Rebuild level control valves.
3. Rebuild flow control Valves and Hydraulic shut off valves.
4. Check power dip shut down.
5. Pull and calibrate carbon bed temperature switches.
6. Check and record Amp draws and Meg Ohm readings on (A) Pump Motors.

QUARTERLY CHECK #3A

1. Remove and inspect Supply Pump Check Valve.
2. Remove and inspect Return Pump Check Valves.
3. Check and record Amp draws and Meg Ohm readings on (B) Pump Motors.
4. Check Belt on Vacuum Pump (P3).

QUARTERLY CHECK #3B

1. Remove and inspect Vacuum Pump Suction Check Valves.
2. Check and record Amp draws and Meg Ohm readings on (B) Pump Motors.
3. Check Belts on Vacuum Pump (P4).

1. Ambient Temp. 72° Time on Hour Meter — Time of Day —

BED A

BED B

2. Purge air setting HG^{vac} 28.3 Purge air setting HG^{vac} 28.5
 3. Minimum flow setting HG^{vac} 29.5 Minimum flow setting HG^{vac} 29.5
 4. Improper regen. setting HG^{vac} 25 Improper regen. setting HG^{vac} 25
 5. Total vacuum time 15 Total vacuum time 15
 6. Total equalization time 86 sec. Total equalization time 89 sec

7. BED A drop on vacuum pump on the 2 stages of opening the V2A valve
 (make certain the vacuum gauge does not drop below 10")

STAGE 1 15 STAGE 2 13

8. BED B drop on vacuum pump on the 2 stages of opening the V2B valve
 (make certain the vacuum gauge does not drop below 10")

STAGE 1 13.5 STAGE 2 15

Taken w/ new 0-30 vac gauge.

9. With both regeneration valves closed, give deepest vacuum observed on the vacuum valve gauge. 29"

10. When BED A equalizes, make certain V4A opens slowly and dusting is not observed. Time required. ok

11. When BED B equalizes, make certain V4B opens slowly and dusting is not observed. Time required. ok

12. Check area light. ok

12A. Check all indicator lights and lenses and replace faulty ones. ok

12B. Calibrate temperature probes.
 NOTE: For temp readings use 1 probe. All within .5° F.

13. Temperature of gasoline from heat exchanger. 69°

14. Temperature of gasoline to heat exchanger. 66°

15. Gasoline heat gain through heat exchanger. 3°

16. Discharge temperature of Glycol at the vacuum pump. 107

17. Temperature of Glycol to the vacuum pump. 75°

18. Heat gain through the vacuum pump. 32°

19. Temperature differential between TI-1B (gasoline from heat exchanger) and TI-1C (glycol from heat exchanger). IF NUMBER IS GREATER THAN FIVE, BRING TO TERMINAL MANAGER'S ATTENTION. IF AT 10 DEGREES, FURTHER INVESTIGATION IS REQUIRED.

6°

20. Check purge heater thermostat.

-

21. Check purge heater for oil leaks.

-

SHUTDOWNS

22. Pull drain plug on vapor tee before shut down and after shut downs. Insure glycol not present. If it is, pull vacuum suction check valve and inspect.

ok

22A. Units that have a Brooks Valve on the supply gasoline line that is used to shut off the gasoline line that acts as VIA valve, insure this valve closes during shut down.

✓

23. Supply pump P1

✓

24. Return pump P2

✓

25. Vacuum pump P3

✓

26. Vacuum pump P4 (if used)

-

27. Seal pump P5

✓

28. Seal low flow P3

✓

29. Seal low flow P4 (if used)

-

30. Emergency Shutdown

✓

31. High level gasoline

✓

32. Low level gasoline

✓

33. Improper regeneration

✓

34. Turn control power off. Insure Fail-safe closes & return line check valve is holding

✓

35. Clean Glycol strainer.

1/2" install npt plug ←

very dirty
4 strainer
n/a

36. Clean gasoline supply strainer if gas supply pressure or flow is low.

cleaned

37. Clean Brooks level control strainer.

repair leak
3" 3/8 nipple

- D. Vacuum pump box P4 (if used) /
- E. Seal pump box (if used) /
- F. Sump pump box /

51. L1 to ground 274 L2 to ground 280 L3 to ground 278
 L1 to L2 481 L2 to L3 480 L1 to L3 487

52. Rated amps to purge heater — Running amps —

53. Rated amps to supply pump ? Running amps 17.5 18 18

54. Rated amps to return pump 19.8 Running amps 15 14.7 14.5

55. Rated amps to seal pump no Tag? Running amps 2.4 2 2.8

56. Rated amps vacuum pump P3 cant Recd? Running amps 94 96 97

57. Rated amps vacuum pump P4 — Running amps —

58. Meg ohm Motors

L1 to GR L2 to GR L3 to GR

Supply pump			
Return pump		no megger ✓	
Seal pump			
Vacuum pump P3			
Vacuum pump P4			

58A. Check condition on all pump couplings and belts visually. ✓

59. Supply pump and coupling OK ok

Return pump and coupling OK ok

Seal pump and coupling OK ok

Vacuum pump and coupling OK Belts

If Belts, Beginning tension _____ Final tension _____

60. Check Glycol concentration and P.H. 89% ph=9

- 60A. Install biocide in unit and leave enough for monthly treatments.
- 61. Check gauge glasses, clean, lubricate, and check for proper operation.
- 62. Level control valve has smooth operation.
- 63. Gas level in separator is stable.
- 64. Inches of Glycol in sight glass.
- 65. Inches of Gasoline in sight glass.
- 66. Time of hour meter _____ n/a Time of day _____
- 67. Is hour meter working properly.
- 68. How many drums of VR coolant does terminal have on hand.

Install 1
* clean Both
____ yes
____ yes
Full glass
14"

____ n/a

COMMENTS * used 2 5/8" glass seals

BED PULL DOWN DATA

VESSEL A		VESSEL B	
TEMP AT START		TEMP AT START	
TOP <u>75</u> F MID <u>70</u> F BOT <u>76</u> F		TOP <u>70</u> F MID <u>72</u> F BOT <u>85</u> F	
MINUTE	HG"VAC	MINUTE	HG"VAC
1	9.5	1	9
2	18.2	2	20
3	23.9	3	24.5
4	26	4	26.5
5	27.5	5	27.2
6	27.7	6	27.7
7	27.9	7	27.9
8	28	8	28.1
9	28.1	9	28.2
10	28.1	10	28.3
11	27.5	11	27.1
12	27.4	12	27
13	27.4	13	27
14	27	14	27
15		15	
16		16	
TEMP AT END:		TEMP AT END:	
TOP <u>75</u> F MID <u>69</u> F BOT <u>56</u> F		TOP <u>70</u> F MID <u>70</u> F BOT <u>45</u> F	

GO THROUGH INSPECTION WITH TERMINAL MANAGER AND EXPLAIN COMPLETELY.

TERMINAL MANAGER'S SIGNATURE

Customer

Cust Signature

CHART T9—ETHYLENE GLYCOL—SPECIFIC GRAVITY

1.1 @ 88°F
= 89%
ph = 9

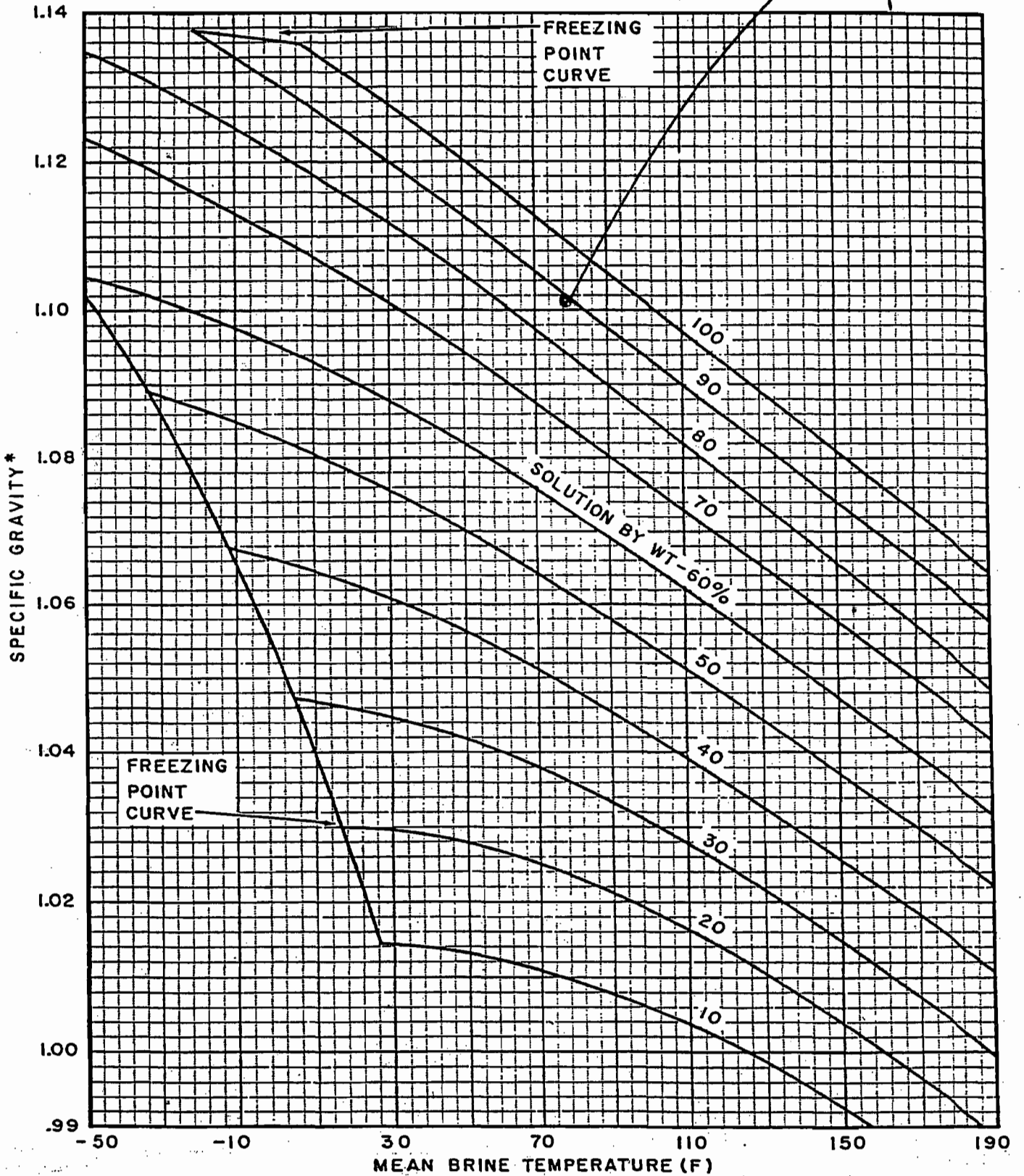

*With reference to 60 F water.



JORDAN TECHNOLOGIES, INC.

P.O. Box 118 Fisherville, Kentucky 40023
Ph: (502) 267-8344 Fax: (502) 267-8379

1st Quarter

Page 1 of 1

Job #

1. BILLING ADDRESS

Customer Name Motiva South
Street Address 1200 SE 28th St.
City / State / Zip Fort Lauderdale, FL 33315
Billing Contact Name & Phone Tom

2. SHIPPING ADDRESS

Customer Name Motiva
Street Address PO Box 21108
City / State / Zip Fort Lauderdale, FL 33335-1108
Terminal Contact Name & Phone

3. LABOR & TRAVEL

Date	Technician	Miles Driven	Std. Labor	Std. Travel	*O.T. Labor	*O.T. Travel	Hol. Labor	Hol. Travel
1-24-03	Andy Zerco		1.5					
1-25-03	Andy Zerco		5.5					
		Totals						

*OT is charged before 8 am, after 5 pm, and on weekends

4. LABOR TYPE & EXPENSES

- P.M.I.
- Service Call
- Bid Job
- Testing
- Sales Call
- Warranty
- Training
- Other
- Airfare
- Car Rental
- Lodging
- Tolls/Parking
- Equip. Rental
- Meals
- Mileage
- Other

5. PARTS & EQUIPMENT

Qty	Item Number	Description
1	64250-000	Truck 19
2	BPL 542	Gauge Valve Set (Pemberton)
1		Biocide
		3/4" Sight glass

6. LABOR PERFORMED & REMARKS

Install Counter on VCU. Flush Drain and Fill seal Pot. Switches High/low level and auto fill were not working. Install new gauge valves. Existing valves were plugged, seized, and could not be repaired. Also install sight glass. Recommend replacing seal pot w/DA. Burners & Control box also in Bad shape. Existing duct not suitable for application. Recommend system overhaul. Auto/Run scully switch needs to be replaced. Will order. New set continuous scully signal. Will Keeling will finish Fri/2 weeks. System running at time of my departure. AZ

Customer Signature AJ House Printed Name AJ House Date 01/24/03 Cust. PO Number 012403

Track 19

JORDAN TECHNOLOGIES, INC.

(M)

FLARE SAFETY INSPECTION SERVICE

TERMINAL NAME: Motiva South

ADDRESS: 1200 SE 28th St.
Fort Lauderdale 33315

PHONE NUMBER: _____

TERMINAL MANAGER: _____

(Please Print)

SERVICE TECHNICIAN: Andy Zorro 1-24-03 1.5 hrs
1-25-03 5 hrs

DATE LAST INSPECTION: _____ DATE THIS INSPECTION 1-24-03
1-25-03

ARRIVAL TIME: 1-24 5:30 DEPARTURE TIME 1-24 7:00
1-25 8:30 1-25 2:00

TERMINAL WAS NOTIFIED PRIOR TO THIS SCHEDULED INSPECTION AND ALL PROBLEMS WERE DISCUSSED WITH TERMINAL MANAGER BEFORE INSPECTION STARTED.

COMMENTS: Installed new gauge valves and Drain
& Flush Seal Pot. Check auto fill and high
level switches. OK AZ (Install Camber)

CUSTOMER SIGNATURE _____

PARTS TO BE INSTALLED THIS INSPECTION:

LOADING RACK CHECK LIST

RACK #1
NUMBER OF LOADING ARMS _____ BACK PRESSURE IN W/C INCHES _____

RACK #2
NUMBER OF LOADING ARMS _____ BACK PRESSURE IN W/C INCHES _____

RACK #3
NUMBER OF LOADING ARMS _____ BACK PRESSURE IN W/C INCHES _____

RACK #4
NUMBER OF LOADING ARMS _____ BACK PRESSURE IN W/C INCHES _____

RACK #5
NUMBER OF LOADING ARMS _____ BACK PRESSURE IN W/C INCHES _____

RACK #6
NUMBER OF LOADING ARMS _____ BACK PRESSURE IN W/C INCHES _____

RACK #7
NUMBER OF LOADING ARMS _____ BACK PRESSURE IN W/C INCHES _____

RACK #8
NUMBER OF LOADING ARMS _____ BACK PRESSURE IN W/C INCHES _____

INSURE ALL HOSES ARE LEAK FREE. MAKE COMMENT BELOW. _____

WHAT PRESSURE DOES THE PRESSURE RELIEF VALVE OPEN? _____

COMMENTS:

NOTE: IF THERE IS A PROBLEM WITH THE LOADING RACK, YOU MUST NOTIFY THE TERMINAL MANAGER AT THIS TIME. THE PROBLEM MUST NOT BE FIXED UNLESS YOU ARE FINISHED WITH THE PMI ON THE VAPOR RECOVERY UNIT. IF THE TERMINAL WANTS PROBLEM FIXED, THIS MUST BE WRITTEN UP ON A SEPARATE INVOICE, TO BE BILLED SEPARATE. THE CLEANING OF FLAME ARRESTOR ETC WILL BE BILLED AT OUR HOURLY RATE PLUS EXPENSES.

THIS HAS BEEN APPROVED BY TERMINAL PERSONNEL AND OVERTIME HAS BEEN APPROVED. HAVE TERMINAL SIGN. _____

TERMINAL PERSONNEL WERE INFORMED OF THIS RACK PROBLEM AND REFUSED TO REPAIR. HAVE TERMINAL SIGN. _____

CONTROL SET POINTS

FLAME ARRESTOR HIGH TEMPERATURE SWITCHES

TSH 104

TSH 105

HIGH STACK TEMPERATURE SWITCH

TSHH-109

HIGH FUEL GAS PRESSURE SWITCH

PSH-602

LOW FUEL GAS PRESSURE SWITCH

PSL-603

HYDRAULIC SEAL LEVEL SWITCHES

LSHH-206

LSL-206

LSLL-206

ASSIST GAS CONTROL TEMP. SETTING

LOWER CONTROL TEMP. SETTING

1. START-UP PROCEDURE

- A. BLOWER TURNS ON FOR THREE MINUTE PURGE.
- B. PILOT AND IGNITION SOLENOID VALVES OPEN.
- C. SPARK PLUG IGNITES EVERY 10 SECONDS UNTIL LIT OR TR-102 TIMES OUT.
- D. IF PILOT FAILS, THE PILOT AND IGNITION GAS VALVES SHOULD CLOSE AND THE SEQUENCE MUST BE REPEATED.
- E. IF PILOT IGNITES BC-106 SCANNER SHOULD PROVE FLAME ALLOWING THE IGNITION SOLENOID TO CLOSE AND THE VAPOR INLET VALVE TO OPEN.

✓

✓

✓

✓

✓

- 2. INSURE PILOT STAYS ON 30 MINUTES AFTER LAST TRUCK HAS DISCONNECTED.
- 3. ASSURE C.V.C. IS REACHING 1400 DEGREES WITHIN TWO MINUTES AND IS MAINTAINING 1500 TO 1600 DEGREES.

<u>seconds</u>	<u>temperature</u>
0	_____
30	_____
60	_____
90	_____
120	_____

- 4. CHECK DAMPER CONTROL AND ASSIST GAS CONTROL IS OPERATING IN ORDER TO PREVENT THE FLARE FROM EXCEEDING 1700 DEGREES.
- 5. CHECK LIQUID LEVEL IN HYDRAULIC SEAL AND REPLACE IF NECESSARY.
- 6. CHECK AND ASSURE PROPER OPERATION OF THE AUTOMATIC LEVEL CONTROL IN THE HYDRAULIC SEAL LSL-206.
- 7. CHECK HYDRAULIC SEAL HOLES AND CONE AND ASSURE IT IS COVERED BY LIQUID.

Flush out Add 2 Booids

COMMENTS:

8. INSPECT AND CLEAN ALL FLAME ARRESTORS.

9. CHECK AND CALIBRATE EACH FLAME ARRESTOR TEMPERATURE SWITCH. TSH-104 AND TSH-105.

10. CHECK AND CALIBRATE THE STACK HIGH TEMPERATURES SWITCH TISHH-109.

11. INSPECT THE CONDITION OF EACH BURNER.

12. INSPECT AND CLEAN ALL ACTUATORS.
FV-103
FV-101

13. INSURE FS-102 INLET PRESSURE MONITOR IS SET PROPERLY IN ORDER TO OPEN FV-103.

FS-102 SETTING.

14. INSPECT BLOWER MOTOR, FAN AND DAMPER FOR PROPER OPERATION.

MEG OHM L1 TO GROUND

L2 TO GROUND

L3 TO GROUND

LINE VOLTAGE L1 TO GROUND

L2 TO GROUND

L3 TO GROUND

RATECL AMPS

RUNNING AMPS L1 _____ L2 _____ L3 _____

15. GREASE BLOWER MOTOR AND FAN.

16. OPEN ALL BOXES AND TIGHTEN WIRING AND CHECK HEATERS FOR PROPER OPERATION. CLEAN OUT MOISTURE AND CORROSION AND RESEAL.

17. CHECK SPARK IGNITION PLUG, CLEAN AND REPLACE IF NECESSARY.

18. PULL AND CLEAN PILOT GAS STRAINER BY THE AIR INSPIRATOR.

19. INSPECT AIR INSPIRATOR.

*Burners in Bad condition
Need contact cleaner*

✓ Grease motor & bearing

*✓ Found Scully Auto Run
Switch Bad. Now set
in Run position. Needs
Switch lock.*

✓

SHUTDOWNS

20. CHECK SUMP TANK HIGH LEVEL SWITCH. IT SHOULD SHUT DOWN C.V.C. IF MADE.

21. CHECK TO SEE IF TERMINAL HAS AN EMERGENCY SHUT DOWN SWITCH IN THE OFFICE. IF SO, DOES IT SHUT DOWN THE FLARE AND LOADING RACK?

22. BLOWER FAILURE (FS-407)

✓

23. HIGH HYDRAULIC SEAL LEVEL

✓

24. LOW HYDRAULIC SEAL LEVEL

✓

25. HIGH FUEL GAS PRESSURE

26. LOW FUEL GAS PRESSURE

✓

27. FLAME FAILURE

✓

28. HIGH FLAME ARRESTOR TEMP (TSH 104-TSH 105)

29. HIGH STACK TEMPERATURE (TISHH-109)

30. IF UNIT IS DOWN ON FAULT, MAKE SURE PERMISSIVE SWITCH WILL NOT ALLOW TRUCKS TO LOAD.

★ Switch is set in Run mode.

COMMENTS:

OPERATOR TRAINING DOCUMENTATION

JORDAN TECHNOLOGIES

2820 South English Station Road
P.O. Box 99535
Louisville, KY 40299

August 28, 2003

Mr. Al House
Motiva Enterprises LLC
1200 SE 28th St.
Ft Lauderdale, FL 33335

Phone : (954) 525 5177
Fax: (954) 764 6106

Mr. House

The following terminal personal attended a Vapor Recovery Training class on site at the Motiva South terminal in July of 2002.

Al House, Larry Ulrich, Bill Jackle, Steve Tosi, Bob Redfern and Dave Madsen

The training class consisted of the basic operation for the John Zink vapor recovery unit. The daily checked list the terminal personal fills out was gone over in great detail. Component local of various valves and pumps were gone over to help terminal personal recognize potential problems.

All of the gauges on the VRU were located and what there functions were as well as what they should be reading. The fault indication system was gone over including the operator interface panel. Each fault was discussed and possible causes for each fault were gone over in detail.

Sincerely,

Will Keeling
Southeast Regional Manager
Jordan Technologies

ANNUAL CARBON BED TESTING

The Jordan Service Co., Inc.

P.O. Box 99535

Louisville, KY 40299

Office 502/267-8344 • Telefax 502/267-8379

www.jordantechnologies.com

Vapor Recovery Equipment

March 12, 2002

Mr. Tom Ledbetter
Motiva Enterprises LLC
909 S.E. 24th Street
Ft. Lauderdale, FL 33316

Re: VOC Emission Test Report of Motiva Enterprises LLC
located at the Port Everglades, Florida Transport Loading Terminal

Dear Mr. Ledbetter:

Enclosed are four (4) copies of the February 21, 2002 VOC Emission Test Report conducted on the John Zink Recovery Unit (VRU) at the subject terminal.

Please review and forward to the proper City and/or State officials, as required.

If you have any questions concerning this test report please contact me at your convenience.

Thank you for the opportunity to perform this testing for your facility. We look forward to working with you on future environmental projects.

Respectfully,

Glen D. Toloczko

Glen D. Toloczko
Environmental Testing Manager
THE JORDAN SERVICE COMPANY, INC.

GDT/csj
Enclosures

VOLATILE ORGANIC COMPOUND EMISSION TEST REPORT

OF THE

**MOTIVA ENTERPRISES LLC
NORTH TERMINAL**

**PORT EVERGLADES, FLORIDA TRANSPORT LOADING
TERMINAL**

ON THE

JOHN ZINK CARBON VAPOR RECOVERY UNIT

ON

FEBRUARY 21, 2002

REPORTED BY: The Jordan Service Company
2820 South English Station Road
Louisville, Kentucky 40299
Office: (502) 267-8344
Fax: (502) 267-8379
Email: gtoloczko@jordantech.com

TEST PERSONNEL: GLEN TOLOCZKO
TONY FENTON

APPROVAL:

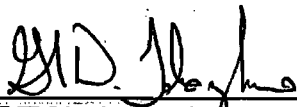

GLEN D. TOLOCZKO
ENVIRONMENTAL TESTING MANAGER
TECHNICAL SERVICE GROUP

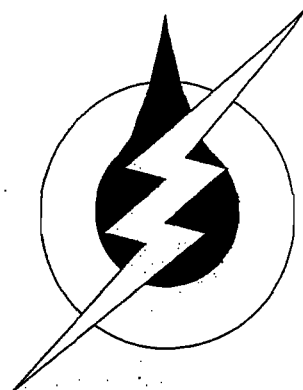

In reference to the Motiva Enterprises LLC Air Emission Source Test conducted at the Port Everglades, Florida North Transport Loading Facility on February 21, 2002 and described in the following report;

I certify under penalty of law that the information provided in this document is true, accurate and complete. I am aware that there are significant civil and criminal penalties, including fines or imprisonment or both, for submitting false, inaccurate or incomplete information.

by: Glen D. Toloczko
Glen D. Toloczko
Technical Service Group
John Jordan Service Co. Inc.

TABLE OF CONTENTS

EXECUTIVE SUMMARY.....	1
TERMINAL OPERATION AND DESCRIPTION.....	2
VAPOR RECOVERY SYSTEM.....	3
MEASUREMENT TECHNIQUES.....	4
TEST EQUIPMENT.....	5
EXAMPLE CALCULATIONS.....	6-7
TEST RESULTS.....	8
SCHEMATIC OF TERMINAL.....	9
VAPOR RECOVERY UNIT.....	10
VAPOR RECOVERY UNIT TEST SCHEMATIC.....	11
APPENDIX A.....TRUCK MONITORING DATA SHEETS	
APPENDIX B.....INSTRUMENT AND CALIBRATION INFORMATION	
APPENDIX C.....COMPUTER PRINTOUT, VOC ANALYZER STRIP CHARTS	

EXECUTIVE SUMMARY

The Motiva Enterprises LLC North terminal in Port Everglades, Florida is a bulk transport loading facility for Gasoline Products.

The products are bottom loaded into transport tankers and the displaced hydrocarbon vapors are piped to a vapor holding tank and then to a JOHN ZINK CARBON ADSORPTION / ABSORPTION VAPOR RECOVERY UNIT (VRU).

The VRU at this facility was source tested for air emissions on February 21, 2002. The purpose of this test was to confirm proper operation of the VRU and verify compliance with applicable VOC (Volatile Organic Compound) air emission requirements.

The Gasoline Terminal Air Emission Source Test was conducted in accordance with procedures established, and the test methods referenced, in the Code of Federal Regulations; CFR 40, Part 60, Subpart XX. Specific procedures used include:

EPA TEST METHOD

MEASUREMENT

Method 2A	Exhaust Vapor Volume
Method 25B	Inlet and Outlet VOC Concentrations
Method 21	Potential Leak Sources
40 CFR 60 Subsection 60.503 (d)	Transport Loading Maximum Backpressure

The results of this air emission test demonstrate that this source is in compliance with all applicable Federal and Local requirements. A summary of the data is presented below:

<u>TEST PARAMETER</u>	<u>MEASURED VALUE</u>	<u>REQUIRED VALUE</u>
VOC Emissions	1.33 mg/liter	35 mg/liter

The vapor piping connecting the tanker trucks to the Vapor Recovery Units was tested for leaks above 10,000 PPMVOL as Methane prior to beginning the test. A portable hydrocarbon analyzer was used for this testing. It was calibrated prior to its use with a certified 10,000 PPM Methane calibration gas. No leaks above 10,000 PPM Methane were found.

TERMINAL OPERATION AND DESCRIPTION

There are three loading bays equipped to load Regular, Midgrade, and Premium Unleaded Gasoline onto transports.

Each bay is equipped with vapor recovery hoses positioned at the transport loading positions for hook up to the Vapor Control System. The vapor hoses and associated piping transports the vapors to a vapor holding tank and then to the VRU. The vapor piping system also employs a liquid knock-out tank and pressure / vacuum relief vent upstream from the VRU.

A general overview of the loading rack layout is shown on page 9.

JOHN ZINK VAPOR RECOVERY UNIT

The terminal is equipped with a John Zink Adsorption / Absorption Gasoline Vapor Recovery Units. Hydrocarbon vapors enter the John Zink VRU into one of two Carbon Adsorbers. The Hydrocarbon - air mixture flows up through the absorber where the bulk of the hydrocarbons are absorbed. The air continues through the Carbon Adsorber and is vented to the atmosphere. The saturated carbon is then desorbed by employing vacuum regeneration at 27.5" Hg Vacuum, while the second Carbon Adsorber is receiving the hydrocarbon - air mixture generated in transport loading activity. The purpose of regeneration is to restore the carbon to a level where it will effectively adsorb hydrocarbons again. The two carbon adsorbers alternate between adsorption and regeneration at 15 minute intervals.

When a Carbon Adsorber is in the regeneration mode, a liquid ring vacuum pump pulls the hydrocarbon from the carbon. The rich hydrocarbon vapors from the Carbon Adsorber are mixed with the vacuum pump seal fluid and are discharged to an Absorber / Separator.

The liquid hydrocarbons are condensed and separated from the seal fluid in the separator compartment and are discharged back to a holding tank. Any remaining hydrocarbons pass up through the packed Absorber tower and are contacted by a fresh stream of gasoline which absorbs most of the remaining hydrocarbons. The small amount of hydrocarbons that is left then leaves the top of the absorber and is directed back to the Carbon Adsorber where the whole process is repeated.

A typical John Zink Vapor Recovery Unit is illustrated schematically on page 10.

MEASUREMENT AND DATA ANALYSIS

The NonDispersive InfraRed (NDIR) analyzer, turbine flow meter, exhaust vapor thermistor and exhaust pressure transducer are connected to the VRU exhaust stack in order to acquire their respective data. A quad check valve assembly is employed to provide for proper VRU regeneration air flow and allow one turbine meter to satisfy both carbon vessel measurement requirements.

The barometric pressure transducer and ambient thermistor are located in close proximity to the VRU in order to acquire ambient atmospheric conditions for use in subsequent standardization equations. A test schematic depicting general test equipment configuration is included as Figure 3.

Each transducer data channel is scaled and connected to the computer input board. Using an operations code program each input channel is read 25 times in a 5 second interval and mass, flow, concentration, temperature, and pressure values are averaged and stored in an array for subsequent use.

After sixty 5 second intervals (5 minutes) the hard disk array is polled and average values are determined for concentration, pressure, and temperature. These values along with the flow for the 5 minute period are used to compute the mass emitted for that 5 minute period. These averaged and summed values are then printed out as the 5 minute interval data and are again stored on hard disk until the six hour test period is completed.

Upon completion of the test, the 5 minute interval data is polled to determine test averages for Inlet and Outlet VOC concentration, pressure and temperature data for all test intervals during which VRU exhaust flow was greater than zero and volume and milligram emission data is summed for all 5 minute periods to arrive at a final test period total.

This data acquisition methodology essentially represents a series of very short (5 second) intervals during which VRU operation is measured, averaged and standardized. This effectively removes all judgmental decisions from data reduction processes and provides a technically unbiased analysis of VRU operation.

Additionally, pretest and post test vapor analyzer calibrations are conducted, along with an hourly analyzer calibration drift check verification. Following the conclusion of the six hour test the loading rack volumes are calculated and final mass emission values are determined.

Copies of the transport loading rack sheets, hydrocarbon analyzer strip charts and computer print outs are attached as Appendices to this test report.

TEST EQUIPMENT

<u>Quantity</u>	<u>Item</u>
2	Thermistor Temperature Probes
1	IBM Compatible Computer with 16 Channel, 12 bit A/D Input Card
1	GasTech Model GT Series Portable Hydrocarbon Analyzer
1	Setra Model #261 (or #264) Variable Differential Pressure Transducer
1	Setraceram Model #361 (or #304) Digital Barometer
1	American Meter Co. 8" Turbine Flow Meter
1 (or 2)	Strip Chart Recorder, either: Yokogawa uR 1800 Six Channel Chart Recorder
2	NonDispersive InfraRed Analyzers (NDIR), either: 1 Horiba PIR-2000 – Inlet VOC Analyzer 1 Summit Industries Model 703D – Outlet VOC Analyzer

All equipment specifications are shown in Appendix B along with available calibration and accuracy information.

EXAMPLE CALCULATIONS

A. Terminology:

- T_a = Ambient Temperature ($^{\circ}$ Celsius).
 P_b = Barometric Pressure (mm Hg).
 L_t = Total volume of liquid dispensed from all controlled racks during the test period (Liters).
 V_e = Volume of air-hydrocarbon mixture exhausted from the processing unit (cubic meters).
 V_{es} = Normalized volume of air-hydrocarbon mixture exhausted (Cubic meters at 20° Celsius, 760 mm Hg).
 C_e = Volume fraction of hydrocarbons in exhausted mixture (Volume % as $C_3H_8/100$, corrected for methane content, if required).
 T_e = Temperature at process unit exhaust ($^{\circ}$ Celsius).
 P_e = Pressure at processing unit exhaust (mm Hg. absolute).
 M_e = Mass of VOC emitted (milligrams).
 $(M/L)_e$ = Mass of hydrocarbons exhausted from the processing unit per volume of liquid loaded (mg/liter).
 $(M/T)_e$ = Mass of hydrocarbons exhausted from the processing unit per unit time (lb/hour).

Constants:

- $0.3858 = (273.2^{\circ} C + 20^{\circ} C) / (760 \text{ mm Hg})$ Normalization Factor.
 $1.83 \times 10^6 \text{ mg/m}^3 =$ Standard Density of Propane (C^3H^8).
 $454,000 =$ Conversion Factor mg/lb.
 $3.785 =$ Conversion Factor Liter/Gallon.
 $264.2 =$ Conversion Factor gallons / meter³

B. Calculate the Following Results for Each Period of the Vapor Control System Operation:

- (1.) Volume of air-hydrocarbon mixture exhausted from the vapor control system:

$$V_e = (V_{ef} - V_{ei}) \quad (\text{meters}^3)$$

(where subscript f refers to final and subscript i refers to initial)
 $V_e =$ Totalized volume from flow rate and time records.

- (2.) Normalized volume of exhausted mixture:

$$V_{es} = \frac{(0.3858^{\circ} \text{ Kelvin/mm Hg}) \times V_e \times P_e}{(T_e + 273.2)} \quad (\text{meter}^3)$$

- (3.) Mass of hydrocarbons exhausted from the vapor control system:

$$M_e = \frac{(1.83 \times 10^6 \text{ mg } C^3H^8)}{\text{meter}^3} \times (V_{es}) \times (C_e) \quad (\text{mg}) \quad (\text{equation B})$$

C. Calculate the Average Mass of Hydrocarbons Emitted Per Volume of Gasoline Loaded:

$$(M/L)_e = M_e/L_t \quad (\text{mg/liter})$$

D. Calculate the Average Mass of Hydrocarbons Emitted Per Unit Time:

$$(M/T)_e = (M/L)_e \times \frac{1 \text{ lb} \times 3.785 \text{ liter} \times \text{Acct. Gal}}{454,000 \text{ mg} \quad 1 \text{ gal} \quad \text{Test Time}} \quad (\text{lb/hr})$$

E. Calculation for Efficiency (if used):

$$\text{Unit Efficiency} = [1 - (\text{outlet mg} / \text{inlet mg})] \times 100\%$$

Where inlet milligrams is derived using inlet concentration and volume of liquid loaded onto transports, assuming a vapor growth ratio of 1:1 and no gross leaks.

F. Example ME Calculation For a Typical Five Minute Interval:

This is an example calculation only, and not an interval from this test. This is intended to clarify the computer method for arriving at the VOC mass emitted data for each test interval.

Barometric Pressure (Baro-P) = 768.4 mm Hg	Volume Emitted (VE) = 42.9 m ³
Exhaust Pressure (Exhaust-P) = 1.0 mm Hg	Milligrams Emitted (ME) = 436931.5 mg
Ambient Temperature (Ambient-T) = 16.8° C	Outlet VOC Concentration = 0.55 %
Exhaust Temperature (Exhaust-T) = 18.3° C	Inlet VOC Concentration = 34.0 %
Volume Emitted Standardized (VES) = 43.6 m ³	

Please Note: All data fields are rounded to two places following the decimal point for display purposes only.

1.) Therefore, for this calculation:

$$\begin{aligned} &0.545 \% \text{ lowest possible value before rounding for display} \\ \text{HCout} &= \mathbf{0.55 \% \text{ value displayed (after rounding)}} \\ &0.554 \% \text{ highest possible value before rounding for display} \\ \\ &43.55 \text{ m}^3 \text{ lowest possible value before rounding for display} \\ \text{VES} &= \mathbf{43.6 \text{ m}^3 \text{ value displayed (after rounding)}} \\ &43.64 \text{ m}^3 \text{ highest possible value before rounding for display} \end{aligned}$$

2.) Using the above values in the previous equation B we have:

$$\begin{aligned} (1.83 \times 10^6) \times (0.00545) \times (43.55) &= 434,345.9 \text{ mg} \\ &436,931.5 \text{ mg} \\ (1.83 \times 10^6) \times (0.0055) \times (43.6) &= \mathbf{438,834.0 \text{ mg}} \\ (1.83 \times 10^6) \times (0.00554) \times (43.64) &= 442,431.0 \text{ mg} \end{aligned}$$

Note: The value for ME printed by the computer for this interval is **436,931.5 mg**. While this is not the result produced from entering the printed values for HCout and VES into Equation B, it is the result produced by the calculation carried out on the stored computer data, prior to rounding for display.

DATA SUMMARY

TERMINAL DESCRIPTION	Motiva Enterprises LLC Port Everglades, FL
VAPOR CONTROL UNIT TYPE	John Zink VRU
TEST DATE	February 21, 2002
TEST PERIOD	08:16 – 14:16
AVERAGE AMBIENT TEMPERATURE	79.2° F
AVERAGE OUTLET CONCENTRATION (as Propane)	0.21 % by Volume
AVERAGE INLET CONCENTRATION (as Propane)	60.84 % by Volume
TOTAL PETROLEUM LOADED	193,295 gallons
ACCOUNTABLE PETROLEUM LOADED	184,590 gallons
AVERAGE HYDROCARBON EMISSIONS (Calculated with Total Loaded Product)	1.27 mg/liter 0.34 lb/hr
AVERAGE HYDROCARBON EMISSIONS (Calculated with Accountable Product Loaded)	1.33 mg/liter 0.34 lb/hr
NUMBER OF TRUCKS LOADED	26
NUMBER OF LEAKING TRUCKS	1
VOLUME OF LEAKING TRUCKS	8,800 gallons
MAXIMUM PRESSURE AT TRUCK VAPOR HOSE	10.0" H ₂ O
STRIP CHART RECORDER SPEED	150 mm/hour
UNIT EFFICIENCY	99.89 %

-9-
Figure 1.

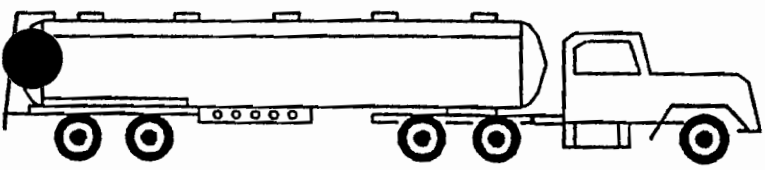

MOTIVA ENTERPRISES LLC
FORT LAUDERDALE, FL

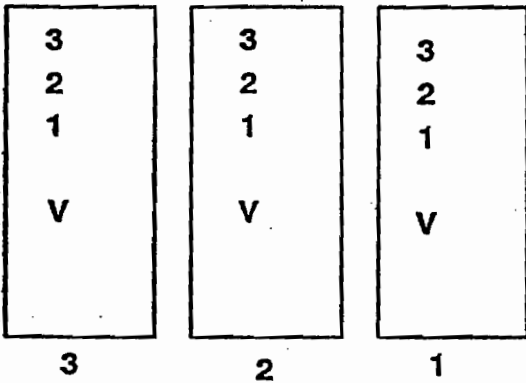
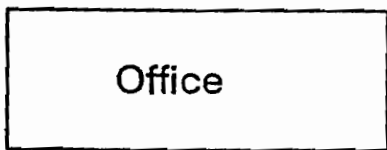

LEGEND

- V - V.R. Hose
- 1 - Regular
- 2 - Premium
- 3 - Plus

Vapor
Holding
Tank

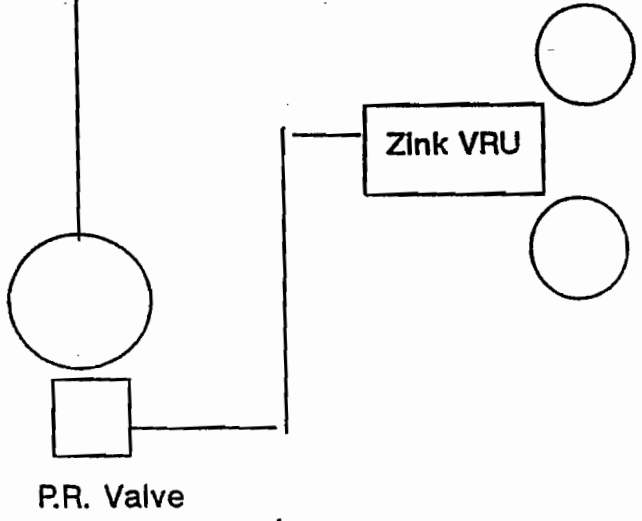

NOTE: Not Drawn to Scale

VAPOR RECOVERY UNIT TEST SCHEMATIC

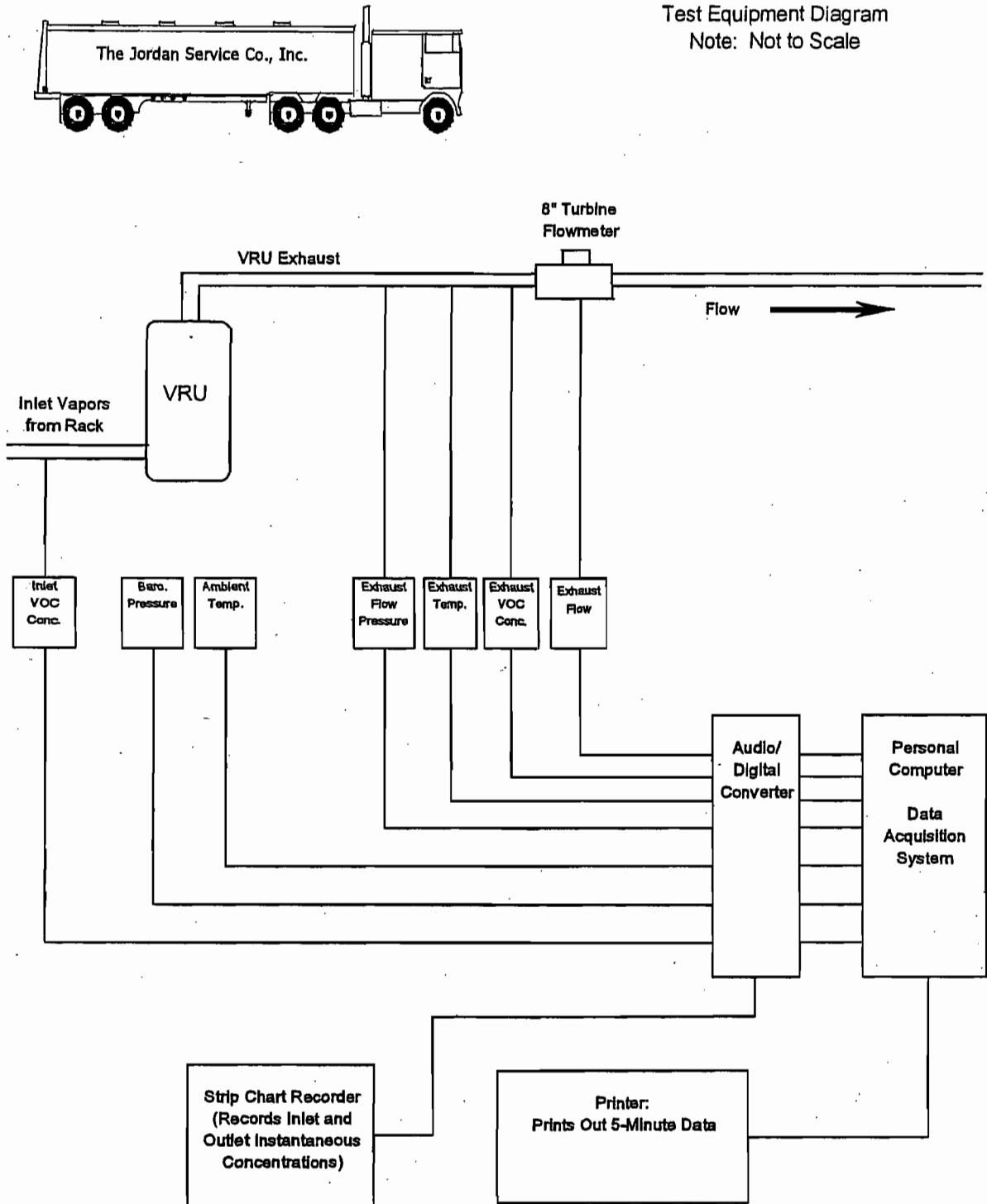

Test Equipment Diagram
Note: Not to Scale

APPENDIX A

Seq. No. <u>1</u>	Tanker Name <u>MOTIVA</u>	Load Start Time <u>8:30</u>		
Bay No. <u>1</u>	Trailer Number <u>44040</u>	Load Stop Time <u>8:39</u>		
Products Loading	Previous Product	Leak	Accountable Gallons	Non-Acct. Gallons
<u>GAS</u>	<u>GAS</u>	<u>✓</u>	<u>9000</u>	

Max. Back Pressure: Reading 1 9" Reading 2 8" Reading 3 9" Reading 4 9" Highest 9"

Seq. No. <u>2</u>	Tanker Name <u>MOTIVA</u>	Load Start Time <u>9:14</u>		
Bay No. <u>1</u>	Trailer Number <u>44039</u>	Load Stop Time <u>9:27</u>		
Products Loading	Previous Product	Leak	Accountable Gallons	Non-Acct. Gallons
<u>GAS</u>	<u>GAS</u>	<u>✓</u>	<u>9000</u>	

Max. Back Pressure: Reading 1 9" Reading 2 9" Reading 3 10" Reading 4 9" Highest 10"

Seq. No. <u>3</u>	Tanker Name <u>MOTIVA</u>	Load Start Time <u>9:17</u>		
Bay No. <u>2</u>	Trailer Number <u>02851</u>	Load Stop Time <u>9:29</u>		
Products Loading	Previous Product	Leak	Accountable Gallons	Non-Acct. Gallons
<u>GAS</u>	<u>GAS</u>	<u>"</u>	<u>9000</u>	

Max. Back Pressure: Reading 1 5" Reading 2 7" Reading 3 6" Reading 4 6" Highest 7"

Seq. No. <u>4</u>	Tanker Name <u>Youngs Oil Co.</u>	Load Start Time <u>9:18</u>		
Bay No. <u>3</u>	Trailer Number <u>292</u>	Load Stop Time <u>9:29</u>		
Products Loading	Previous Product	Leak	Accountable Gallons	Non-Acct. Gallons
<u>GAS</u>	<u>DIESEL</u>	<u>✓</u>	<u>2600</u>	

Max. Back Pressure: Reading 1 9" Reading 2 9" Reading 3 8" Reading 4 9" Highest 9"

Seq. No. <u>5</u>	Tanker Name <u>STAR FLEET TEXACO</u>	Load Start Time <u>9:35</u>		
Bay No. <u>1</u>	Trailer Number <u>98213</u>	Load Stop Time <u>9:55</u>		
Products Loading	Previous Product	Leak	Accountable Gallons	Non-Acct. Gallons
<u>GAS</u>	<u>DIESEL</u>		<u>7200</u>	

Max. Back Pressure: Reading 1 _____ Reading 2 _____ Reading 3 _____ Reading 4 _____ Highest _____

Seq. No. <u>6</u>	Tanker Name <u>KENAP</u>	Load Start Time <u>9:42</u>		
Bay No. <u>3</u>	Trailer Number <u>5725</u>	Load Stop Time <u>9:55</u>		
Products Loading	Previous Product	Leak	Accountable Gallons	Non-Acct. Gallons
<u>GAS</u>	<u>GAS</u>	<u>✓</u>	<u>8900</u>	

Max. Back Pressure: Reading 1 9" Reading 2 8" Reading 3 7" Reading 4 7" Highest 9"

Accountable Gallons Load 1	<u>9000</u>	Total Gallons Load 1	<u>9000</u>
Accountable Gallons Load 2	<u>9000</u>	Total Gallons Load 2	<u>9000</u>
Accountable Gallons Load 3	<u>9000</u>	Total Gallons Load 3	<u>9000</u>
Accountable Gallons Load 4	<u>2600</u>	Total Gallons Load 4	<u>2600</u>
Accountable Gallons Load 5	<u>7200</u>	Total Gallons Load 5	<u>7200</u>
Accountable Gallons Load 6	<u>8900</u>	Total Gallons Load 6	<u>8900</u>

Seq. No. <u>7</u>	Tanker Name <u>MOTIV</u>	Load Start Time <u>9:46</u>		
Bay No. <u>2</u>	Trailer Number <u>02848</u>	Load Stop Time <u>10:01</u>		
Products Loading	Previous Product	Leak	Accountable Gallons	Non-Acct. Gallons
<u>GAS</u>	<u>GAS</u>	<u>✓</u>	<u>9000</u>	

Max. Back Pressure: Reading 1 _____ Reading 2 _____ Reading 3 _____ Reading 4 _____ Highest _____

Seq. No. <u>8</u>	Tanker Name <u>PENN TANK LINES</u>	Load Start Time <u>10:02</u>		
Bay No. <u>3</u>	Trailer Number <u>794</u>	Load Stop Time <u>10:20</u>		
Products Loading	Previous Product	Leak	Accountable Gallons	Non-Acct. Gallons
<u>GAS</u>	<u>GAS</u>	<u>✓</u>	<u>6800</u>	

Max. Back Pressure: Reading 1 5" Reading 2 7" Reading 3 7" Reading 4 7" Highest 7"

Seq. No. <u>9</u>	Tanker Name <u>MOTIV</u>	Load Start Time <u>10:02</u>		
Bay No. <u>1</u>	Trailer Number <u>44038</u>	Load Stop Time <u>10:16</u>		
Products Loading	Previous Product	Leak	Accountable Gallons	Non-Acct. Gallons
<u>GAS</u>	<u>GAS</u>	<u>✓</u>	<u>9000</u>	

Max. Back Pressure: Reading 1 8" Reading 2 7" Reading 3 6" Reading 4 6" Highest 8"

Seq. No. <u>10</u>	Tanker Name <u>KENAW</u>	Load Start Time <u>10:07</u>		
Bay No. <u>2</u>	Trailer Number <u>5724</u>	Load Stop Time <u>10:30</u>		
Products Loading	Previous Product	Leak	Accountable Gallons	Non-Acct. Gallons
<u>GAS</u>	<u>GAS</u>	<u>REAR DOME LID</u>	<u>8800</u>	<u>8800</u>

Max. Back Pressure: Reading 1 _____ Reading 2 _____ Reading 3 _____ Reading 4 _____ Highest _____

Seq. No. <u>11</u>	Tanker Name <u>KENAW</u>	Load Start Time <u>10:19</u>		
Bay No. <u>1</u>	Trailer Number <u>5726</u>	Load Stop Time <u>10:32</u>		
Products Loading	Previous Product	Leak	Accountable Gallons	Non-Acct. Gallons
<u>GAS</u>	<u>GAS</u>	<u>✓</u>	<u>7100</u>	

Max. Back Pressure: Reading 1 _____ Reading 2 _____ Reading 3 _____ Reading 4 _____ Highest _____

Seq. No. <u>12</u>	Tanker Name <u>KENAW</u>	Load Start Time <u>10:26</u>		
Bay No. <u>2</u>	Trailer Number <u>5133</u>	Load Stop Time <u>10:48</u>		
Products Loading	Previous Product	Leak	Accountable Gallons	Non-Acct. Gallons
<u>GAS</u>	<u>GAS</u>	<u>✓</u>	<u>8795</u>	

Max. Back Pressure: Reading 1 _____ Reading 2 _____ Reading 3 _____ Reading 4 _____ Highest _____

Accountable Gallons Load 1	<u>9000</u>	Total Gallons Load 1	<u>9000</u>
Accountable Gallons Load 2	<u>6800</u>	Total Gallons Load 2	<u>6800</u>
Accountable Gallons Load 3	<u>9000</u>	Total Gallons Load 3	<u>9000</u>
Accountable Gallons Load 4	<u>0</u>	Total Gallons Load 4	<u>8800</u>
Accountable Gallons Load 5	<u>7100</u>	Total Gallons Load 5	<u>7100</u>
Accountable Gallons Load 6	<u>8795</u>	Total Gallons Load 6	<u>8795</u>

total Accountable Gallons This Page 40695 total Gallons This Page 49495
 Acct. Total From Previous Page + 45700 total Gallons Prev. Page + 45700

Seq. No. <u>13</u>	Tanker Name <u>MOTIVA</u>	Load Start Time <u>10:41</u>		
Bay No. <u>1</u>	Trailer Number <u>02850</u>	Load Stop Time <u>10:53</u>		
Products Loading	Previous Product	Leak	Accountable Gallons	Non-Acct. Gallons
<u>GAS</u>	<u>GAS</u>	<u>✓</u>	<u>9000</u>	

Max. Back Pressure: Reading 1 7" Reading 2 9" Reading 3 8" Reading 4 8" Highest 7"

Seq. No. <u>14</u>	Tanker Name <u>MOTIVA</u>	Load Start Time <u>10:52</u>		
Bay No. <u>2</u>	Trailer Number <u>44039</u>	Load Stop Time <u>11:07</u>		
Products Loading	Previous Product	Leak	Accountable Gallons	Non-Acct. Gallons
<u>GAS</u>	<u>GAS</u>	<u>✓</u>	<u>9000</u>	

Max. Back Pressure: Reading 1 _____ Reading 2 _____ Reading 3 _____ Reading 4 _____ Highest _____

Seq. No. <u>15</u>	Tanker Name <u>KEWAN</u>	Load Start Time <u>11:02</u>		
Bay No. <u>1</u>	Trailer Number <u>5725</u>	Load Stop Time <u>11:15</u>		
Products Loading	Previous Product	Leak	Accountable Gallons	Non-Acct. Gallons
<u>GAS</u>	<u>GAS</u>	<u>✓</u>	<u>8900</u>	

Max. Back Pressure: Reading 1 _____ Reading 2 _____ Reading 3 _____ Reading 4 _____ Highest _____

Seq. No. <u>16</u>	Tanker Name <u>STAR FUSET TEMACO</u>	Load Start Time <u>11:11</u>		
Bay No. <u>2</u>	Trailer Number <u>95-211</u>	Load Stop Time <u>11:18</u>		
Products Loading	Previous Product	Leak	Accountable Gallons	Non-Acct. Gallons
<u>GAS</u>	<u>DIESEL</u>	<u>✓</u>	<u>1000</u>	

Max. Back Pressure: Reading 1 _____ Reading 2 _____ Reading 3 _____ Reading 4 _____ Highest _____

Seq. No. <u>17</u>	Tanker Name <u>KEWAN</u>	Load Start Time <u>11:35</u>		
Bay No. <u>2</u>	Trailer Number <u>5089</u>	Load Stop Time <u>11:45</u>		
Products Loading	Previous Product	Leak	Accountable Gallons	Non-Acct. Gallons
<u>GAS</u>	<u>DIESEL</u>	<u>✓</u>	<u>1200</u>	

Max. Back Pressure: Reading 1 _____ Reading 2 _____ Reading 3 _____ Reading 4 _____ Highest _____

Seq. No. <u>18</u>	Tanker Name <u>MOTIVA</u>	Load Start Time <u>11:33</u>		
Bay No. <u>3</u>	Trailer Number <u>02851</u>	Load Stop Time <u>11:47</u>		
Products Loading	Previous Product	Leak	Accountable Gallons	Non-Acct. Gallons
<u>GAS</u>	<u>GAS</u>	<u>✓</u>	<u>9000</u>	

Max. Back Pressure: Reading 1 _____ Reading 2 _____ Reading 3 _____ Reading 4 _____ Highest _____

Accountable Gallons Load 1	<u>9000</u>	Total Gallons Load 1	<u>9000</u>
Accountable Gallons Load 2	<u>9000</u>	Total Gallons Load 2	<u>9000</u>
Accountable Gallons Load 3	<u>8900</u>	Total Gallons Load 3	<u>8900</u>
Accountable Gallons Load 4	<u>1000</u>	Total Gallons Load 4	<u>1000</u>
Accountable Gallons Load 5	<u>1200</u>	Total Gallons Load 5	<u>1200</u>
Accountable Gallons Load 6	<u>9000</u>	Total Gallons Load 6	<u>9000</u>

Seq. No. <u>19</u>	Tanker Name <u>MOTIVA</u>	Load Start Time <u>11:36</u>		
Bay No. <u>1</u>	Trailer Number <u>44040</u>	Load Stop Time <u>11:45</u>		
Products Loading	Previous Product	Leak	Accountable Gallons	Non-Acct. Gallons
<u>GAS</u>	<u>GAS</u>	<u>✓</u>	<u>9000</u>	

Max. Back Pressure: Reading 1 _____ Reading 2 _____ Reading 3 _____ Reading 4 _____ Highest _____

Seq. No. <u>20</u>	Tanker Name <u>MOTIVA</u>	Load Start Time <u>11:50</u>		
Bay No. <u>1</u>	Trailer Number <u>44038</u>	Load Stop Time <u>12:04</u>		
Products Loading	Previous Product	Leak	Accountable Gallons	Non-Acct. Gallons
<u>GAS</u>	<u>GAS</u>	<u>✓</u>	<u>9000</u>	

Max. Back Pressure: Reading 1 10" Reading 2 8" Reading 3 9" Reading 4 5" Highest 10"

Seq. No. <u>21</u>	Tanker Name <u>PENN TANK</u>	Load Start Time <u>12:06</u>		
Bay No. <u>2</u>	Trailer Number <u>794</u>	Load Stop Time <u>12:07</u>		
Products Loading	Previous Product	Leak	Accountable Gallons	Non-Acct. Gallons
<u>GAS</u>	<u>GAS</u>	<u>✓</u>	<u>1000</u>	

Max. Back Pressure: Reading 1 _____ Reading 2 _____ Reading 3 _____ Reading 4 _____ Highest _____

Seq. No. <u>22</u>	Tanker Name <u>KENAN</u>	Load Start Time <u>12:54</u>		
Bay No. <u>1</u>	Trailer Number <u>5133</u>	Load Stop Time <u>1:06</u>		
Products Loading	Previous Product	Leak	Accountable Gallons	Non-Acct. Gallons
<u>GAS</u>	<u>GAS</u>	<u>✓</u>	<u>8795</u>	

Max. Back Pressure: Reading 1 _____ Reading 2 _____ Reading 3 _____ Reading 4 _____ Highest _____

Seq. No. <u>23</u>	Tanker Name <u>KENAN</u>	Load Start Time <u>12:56</u>		
Bay No. <u>2</u>	Trailer Number <u>508A</u>	Load Stop Time <u>1:12</u>		
Products Loading	Previous Product	Leak	Accountable Gallons	Non-Acct. Gallons
<u>GAS</u>	<u>GAS</u>	<u>✓</u>	<u>8900</u>	

Max. Back Pressure: Reading 1 _____ Reading 2 _____ Reading 3 _____ Reading 4 _____ Highest _____

Seq. No. <u>24</u>	Tanker Name <u>KENAN</u>	Load Start Time <u>1:04</u>		
Bay No. <u>3</u>	Trailer Number <u>5725</u>	Load Stop Time <u>1:13</u>		
Products Loading	Previous Product	Leak	Accountable Gallons	Non-Acct. Gallons
<u>GAS</u>	<u>GAS</u>	<u>✓</u>	<u>8900</u>	

Max. Back Pressure: Reading 1 _____ Reading 2 _____ Reading 3 _____ Reading 4 _____ Highest _____

Accountable Gallons Load 1	<u>9000</u>	Total Gallons Load 1	<u>9000</u>
Accountable Gallons Load 2	<u>9000</u>	Total Gallons Load 2	<u>9000</u>
Accountable Gallons Load 3	<u>1000</u>	Total Gallons Load 3	<u>1000</u>
Accountable Gallons Load 4	<u>8795</u>	Total Gallons Load 4	<u>8795</u>
Accountable Gallons Load 5	<u>8900</u>	Total Gallons Load 5	<u>8900</u>
Accountable Gallons Load 6	<u>8900</u>	Total Gallons Load 6	<u>8900</u>

otal Accountable Gallons This Page 45595 otal Gallons This Page 45595
 Acct. Total From Previous Page + 124495 otal Gallons Prev. Page + 133295

Seq. No. <u>25</u>	Tanker Name <u>KENAW</u>	Load Start Time <u>1:32</u>
Bay No. <u>1</u>	Trailer Number <u>5723</u>	Load Stop Time <u>1:41</u>
Products Loading	Previous Product	Leak
<u>GAS</u>	<u>GAS</u> <u>DIESEL</u>	<input checked="" type="checkbox"/>
	Accountable Gallons	Non-Acct. Gallons
	<u>8900</u>	

Max. Back Pressure: Reading 1 _____ Reading 2 _____ Reading 3 _____ Reading 4 _____ Highest _____

Seq. No. <u>26</u>	Tanker Name <u>EAGLE</u>	Load Start Time <u>1:34</u>
Bay No. <u>2</u>	Trailer Number <u>2384</u>	Load Stop Time <u>1:43</u>
Products Loading	Previous Product	Leak
<u>GAS</u>	<u>GAS</u> <u>DIESEL</u>	<input checked="" type="checkbox"/>
	Accountable Gallons	Non-Acct. Gallons
	<u>5600</u>	

Max. Back Pressure: Reading 1 _____ Reading 2 _____ Reading 3 _____ Reading 4 _____ Highest _____

Seq. No. <u>27</u>	Tanker Name _____	Load Start Time _____
Bay No. _____	Trailer Number _____	Load Stop Time _____
Products Loading	Previous Product	Leak
	Accountable Gallons	Non-Acct. Gallons

Max. Back Pressure: Reading 1 _____ Reading 2 _____ Reading 3 _____ Reading 4 _____ Highest _____

Seq. No. <u>28</u>	Tanker Name _____	Load Start Time _____
Bay No. _____	Trailer Number _____	Load Stop Time _____
Products Loading	Previous Product	Leak
	Accountable Gallons	Non-Acct. Gallons

Max. Back Pressure: Reading 1 _____ Reading 2 _____ Reading 3 _____ Reading 4 _____ Highest _____

Seq. No. <u>29</u>	Tanker Name _____	Load Start Time _____
Bay No. _____	Trailer Number _____	Load Stop Time _____
Products Loading	Previous Product	Leak
	Accountable Gallons	Non-Acct. Gallons

Max. Back Pressure: Reading 1 _____ Reading 2 _____ Reading 3 _____ Reading 4 _____ Highest _____

Seq. No. <u>30</u>	Tanker Name _____	Load Start Time _____
Bay No. _____	Trailer Number _____	Load Stop Time _____
Products Loading	Previous Product	Leak
	Accountable Gallons	Non-Acct. Gallons

Max. Back Pressure: Reading 1 _____ Reading 2 _____ Reading 3 _____ Reading 4 _____ Highest _____

Accountable Gallons Load 1	<u>8900</u>	Total Gallons Load 1	<u>8900</u>
Accountable Gallons Load 2	<u>5600</u>	Total Gallons Load 2	<u>5600</u>
Accountable Gallons Load 3	_____	Total Gallons Load 3	_____
Accountable Gallons Load 4	_____	Total Gallons Load 4	_____
Accountable Gallons Load 5	_____	Total Gallons Load 5	_____
Accountable Gallons Load 6	_____	Total Gallons Load 6	_____

total Accountable Gallons This Page 14500 total Gallons This Page 14500
 Acct. Total From Previous Page + 170090 total Gallons Prev. Page + 178890

APPENDIX B

SPECIALTY GASES DIV.
P.O. BOX 21007 - 335 BOXLEY AVE.
LOUISVILLE, KY 40221-0007
502-635-7531

CERTIFICATE OF ANALYSIS

CYL NUMBER: FF-32443
APPROX. PRESS: 2000
VALVE CGA: 350
TEST NUMBER: 001013

ANALYTIC METHOD(S):
Gravimetric
Gas Chromatography

TEST RESULTS:
2.53% PROPANE
BALANCE NITROGEN

PRIMARY STANDARD

Specialty Gases

Division

Welders Supply Co. P. O. Box 21007 Louisville, Ky. 40221-0007 (502) 635-7531

CERTIFICATION OF CYLINDER CONTENT ANALYSIS

Cylinder Number	FF-34566
Component Requested	PROPANE
Concentration	4.5 %
Analytic Results	4.50 %
Method of Measure	GRAVIMETRIC
Unit of Measure	Molar PPM
Balance Gas	NITROGEN
Date of analysis	04/02/2001
Certification Period	04/02/2003

Frank Fogarty

SPECIALTY GASES DIV.
P.O. BOX 21007 - 335 BOXLEY AVE.
LOUISVILLE, KY 40221-0007
502-635-7531

CERTIFICATE OF ANALYSIS

CYL NUMBER: FF-20107
APPROX. PRESS: 1000
VALVE CGA: 350
TEST NUMBER: 001013

ANALYTIC METHOD(S):
Gravimetric
Gas Chromatography

TEST RESULTS:
9.09% PROPANE
BALANCE NITROGEN

PRIMARY STANDARD

39



SPECIALTY GASES DIV.
P.O. BOX 21007 - 335 BOXLEY AVE.
LOUISVILLE, KY 40221-0007
502-635-7531

CERTIFICATE OF ANALYSIS

CYL NUMBER: LL-36178
APPROX. PRESS: 475
VALVE CGA: 350
TEST NUMBER: 000830

ANALYTIC METHOD(S):
Gravimetric
Gas Chromatography

TEST RESULTS:
25.11% PROPANE
BALANCE NITROGEN

PRIMARY STANDARD

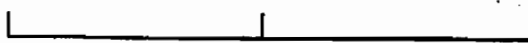

Specialty Gases

45

Division

Welders Supply Co. P. O. Box 21007 Louisville, Ky. 40221-0007 (502) 635-7531

October 17, 2001

The following cylinder was prepared on High Load Balances which are calibrated with Class S Weights traceable to the NIST.

CERTIFICATION OF CYLINDER CONTENT PRIMARY STANDARD

CYLINDER NUMBER	:	LL-25095
REQUESTED AMOUNT	:	50% PROPANE
ACTUAL AMOUNT	:	49.84% PROPANE
BALANCE GAS	:	NITROGEN
METHOD OF PREPARATION:	:	GRAVIMETRIC
ANALYTIC CROSS CHECK :	:	GAS CHROMATOGRAPHY
VALVE CGA	:	350
TEST NUMBER	:	011017
EXPIRATION DATE	:	10/17/2004

Frank Fogarty

29192
17696

49

SPECIALTY GASES DIV.
P.O. BOX 21007 - 335 BOXLEY AVE.
LOUISVILLE, KY 40221-0007
602-635-7531

CERTIFICATE OF ANALYSIS

CYL NUMBER: LL-36180
APPROX. PRESS: 115
VALVE CGA: 350
TEST NUMBER: 001012

ANALYTIC METHOD(S):

Gravimetric
Gas Chromatography

TEST RESULTS:

84.08% PROPANE
BALANCE NITROGEN

PRIMARY STANDARD

SmartLink Instruments

Compact Miniaturized Instruments

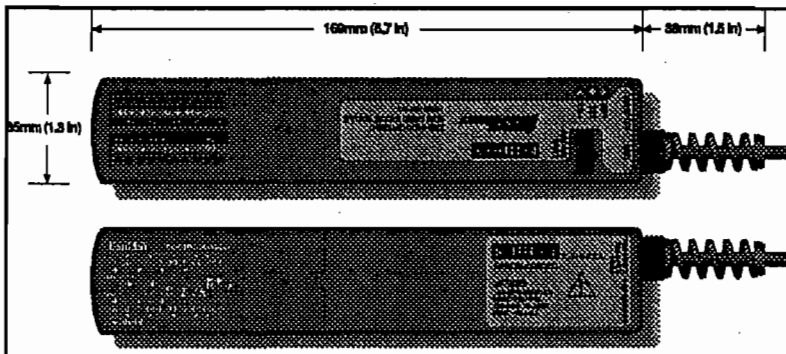

Our compact SmartLink Instruments make lab-grade measurements possible in the field or on the factory floor. These instruments connect directly to complex signals and sensors; collect, process, and store sensor input data; and link directly to your computer or network.

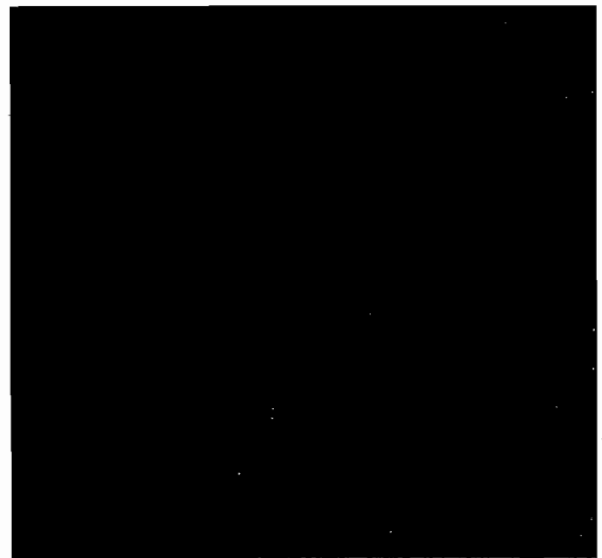

SmartLink Instruments Selector Guide

Model (single/multi ch)	Sensors Measured/ Signals Accommodated	Applications	Key Attributes	Accuracy & Resolution	Analog & Digital I/O
KNM-DCV11, 12 High-speed DCV & ohms measurement system	<ul style="list-style-type: none"> • DCV, DCI, 4-20mA • RTDs, thermistors, ohms • Pressure, flow, & weight transducers • Humidity, RPM • Counter/timer 	<ul style="list-style-type: none"> • Process monitoring • Production test • Transient analysis • Frequency, event, pulse width, vibration analysis 	<ul style="list-style-type: none"> • 31k readings/s burst • External trigger 	<ul style="list-style-type: none"> • 0.1% • 16 bits 	<ul style="list-style-type: none"> • AI: 1/4 • DIO: 2/4 • Recorder output
KNM-DCV31/32 Precision DCV & ohms measurement system	<ul style="list-style-type: none"> • DCV, DCI, 4-20mA • RTDs, thermistors, ohms • Pressure, flow, and weight transducers 	<ul style="list-style-type: none"> • Product reliability testing • High accuracy data acquisition • Production test 	<ul style="list-style-type: none"> • 15 readings/s • High accuracy 	<ul style="list-style-type: none"> • 0.005% • 20 bits 	<ul style="list-style-type: none"> • AI: 1/8 • DO: 2/2
KNM-DCV41/42 Precision Isolated (1500V) DCV & ohms measurement system	<ul style="list-style-type: none"> • DCV, DCI, 4-20mA • RTDs, thermistors, thermocouples, ohms • Pressure, flow, and weight transducers 	<ul style="list-style-type: none"> • Product reliability testing • High accuracy data acquisition • Production test in hostile environments 	<ul style="list-style-type: none"> • 15 readings/s • 1500V isolation to com • 400V inputs 	<ul style="list-style-type: none"> • 0.005% • 20 bits 	<ul style="list-style-type: none"> • AI: 1/8 • DO: 1/1
KNM-RTD31/32 Precision RTD interface	<ul style="list-style-type: none"> • RTD • Hum 	<ul style="list-style-type: none"> • High accuracy temperature monitoring 	<ul style="list-style-type: none"> • 7 readings/s • High accuracy 	<ul style="list-style-type: none"> • 0.02% • 20 bits 	<ul style="list-style-type: none"> • AI: 1/8 • DO: 2/2
KNM-TC41/42 Isolated thermocouple interface	<ul style="list-style-type: none"> • Thermocouples • Millivolts 	<ul style="list-style-type: none"> • High accuracy, high temperature monitoring 	<ul style="list-style-type: none"> • 15 readings/s • 1500V isolation to com • 400V inputs 	<ul style="list-style-type: none"> • 0.5°C • 20 bits 	<ul style="list-style-type: none"> • AI: 1/8 • DO: 1/1
KNM-THM31/32 Temperature, Humidity & dew point system	<ul style="list-style-type: none"> • Temperature • Humidity • Calculated dew point 	<ul style="list-style-type: none"> • Environmental monitoring • HVAC ventilation • ISO 5000 facilities 	<ul style="list-style-type: none"> • 7 readings/s • Onboard sensors 	<ul style="list-style-type: none"> • 0.1% • 20 bits 	<ul style="list-style-type: none"> • AI: 2/2 • DIO: 2/4
KNM-THM31, 32 Precision thermistor	<ul style="list-style-type: none"> • Thermistors • Ohms 	<ul style="list-style-type: none"> • High accuracy temperature monitoring 	<ul style="list-style-type: none"> • 7 readings/s • High accuracy 	<ul style="list-style-type: none"> • 0.03°C • 20 bits 	<ul style="list-style-type: none"> • AI: 1/8 • DO: 2/2



Calibration Certificate

Technician: af
Part No: 350100-01
Model: 2270

Transducer SN: 1154671 Range: 800 to 1100 HPA/MB
Meter SN: 1154671 Nom. Output: 0 to 5 VDC
Work Order: 38043-1 Supply: 24 VDC
Date: 02/10/2000

CALIBRATION DATA

APPLIED PRESSURE (HPA/MB)	TRANSDUCER OUTPUT (VDC)	METER OUTPUT (HPA/MB)	NONLINEARITY ERRORS (% FS)	EXTRAPOLATED ERRORS (% FS)
800.0000	0.0007	800.0	.0.000	Zero 0.000
900.0000	1.6677	900.0	0.000	
1000.0000	3.3325	1000.0	0.000	Span 0.000
1100.0000	4.9990	1100.0	0.000	

SPECIFICATIONS

1. Nonlinearity: +/- 0.05 %FS, END POINT method, ISA.#S-37.1
2. Zero pressure output: 0 VDC +/- 0.1 %FS
3. Full Scale output: 5 VDC +/- 0.1 %FS
4. This unit meets the specifications defined above.

NOTES

1. All errors are expressed as: Percent Full-Scale output.
2. Consult specification sheet for additional specifications.
3. This calibration is certified per N.I.S.T. traceable primary standards.
Primary standard: P2-325/C2-319, NIST# 838/258930-97/DH9195
Primary standard cal. date: 8/26/99
Location of cal.: PCCTR1
4. This part uses spec. record number: 350100-01.9
5. This certificate cannot be reproduced except in full, without the written approval of Setra Systems, Inc.

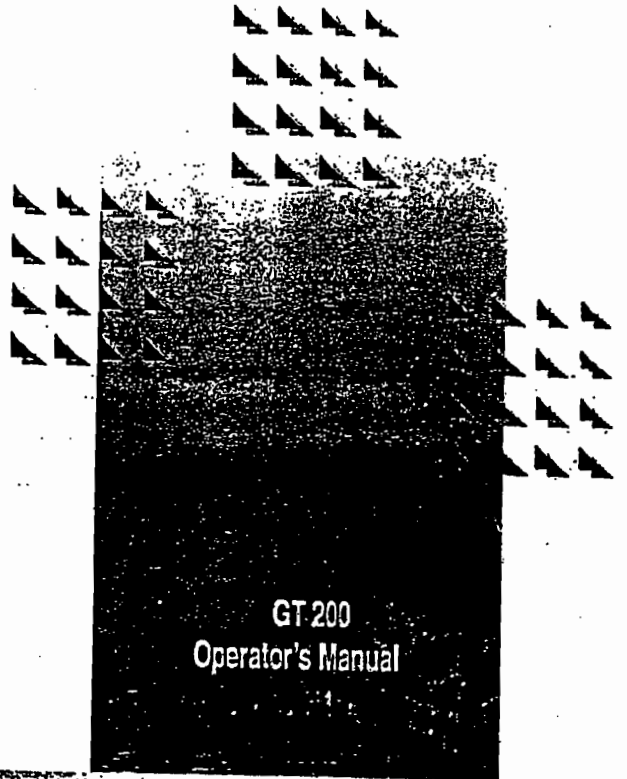

GT 200
Operator's Manual

Chapter

1

INTRODUCTION

This Operator's Manual provides information on the proper set-up, use and maintenance of the GT 200 Series Gas Monitors. Included are complete physical and functional descriptions, with procedures to calibrate and place the monitor in operation. Troubleshooting and maintenance information is also provided.

This chapter contains an overview of the GT Series gas monitors (GT), and information on typical applications, key features, and listings of standard and optional accessories. Complete descriptions appear in later chapters.

DESCRIPTION

GT Series Gas Monitor General Description

The GT 200 Series (shown in Figure 1-1) is a line of portable gas monitors capable of detecting from one to two gases. The GT displays up to two current gas levels simultaneously.

The GT 200 Series is used to monitor an environment for combustible gas, hydrocarbons (LEL/ppm) and oxygen (O₂). The monitor detects gas by a sample-drawing method, utilizing two internal sensors that plug straight into assigned molded flow block receptacles (one receptacle per sensor type).

During operation, the GT alerts you with visual and audible alarms whenever a monitored gas level is significantly different from the preset normal level.

The GT has an internal pump that continually draws the atmosphere sample into the external probe and hose, then into the monitor to the sensor(s).

The GT is powered by four "D" size alkaline or nickel-cadmium (Ni-Cd) batteries. A jack is provided on the GT for connection of the external Ni-Cd battery charger.

The 200 Series

The 200 Series GT gas monitors include two sensors. The following are the current models in the 200 Series, and the gases detected by each. Part numbers for each model are listed in Appendix A, Parts List.

- GT 201: Combustible gas (LEL/ppm) and oxygen (O₂).
- GT 202: Combustible gas (LEL/ppm) and oxygen (O₂) with float-probe.

Standard and optional accessories for the GT 200 Series of instruments are listed at the end of this chapter.

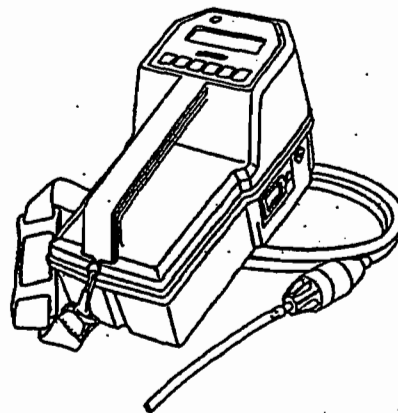

Figure 1-1 GT Series Gas Monitor

SPECIFICATIONS

Table 1-3 lists specifications for the 200 Series of GT Series gas monitor.

TABLE 1-3 Specifications for the GT 200 Series Monitor

Cases Detected	Oxygen (0-30.0% VOL in 0.1% increments) Combustibles (0-100% LEL in 1% increments) Hydrocarbons (0-10,000 ppm in 20 ppm increments)
Sensor	Oxygen: Electrochemical Combustibles: Catalytic compensated
Intrinsic Safety Rating	Class I, Division 1, Groups A, B, C, and D
Sampling Method	Sample-drawing
Response Time	Initial: 5 seconds average (with 5 foot hose) 90% complete within 20 seconds
Accuracy	O ₂ : ± 0.5% by volume LEL: ± 5% of reading ppm: ± 10% of reading
Repeatability	O ₂ : ± 0.2% by volume LEL: ± 2% of reading ppm: ± 5% of reading
Operating Temperature	-4° F (-20° C) to 113° F (45° C)
Humidity	0 to 95% relative humidity (RH), non-condensing
Regulatory Approvals	UL, CSA
Alarms	Audible/visible, coded for gas and trouble. Also a comfort beep that can be turned off.
Alarm Actions	Low flow, low battery, rising combustible reading, rising or falling O ₂ reading, sensor failure
Alarm Functions	Alarm levels are software-selectable by user
Display	Digital liquid crystal display (LCD). Displays up to four different gases at a time. A back light is available on demand.

TABLE 1-3 Specifications for the GT 200 Series Monitor

Power Source	Four "D" size alkaline or Ni-Cd batteries.
Battery life	10 hours (20° C) (Due to the nature of alkaline cells, battery life is greatly reduced at low temperatures, and may be less than 2 hours at -15° C. Ni-Cd batteries are recommended for low temperature applications.)
Controls	ON/OFF (power) button, RESET button, FUNC/+ display option button, BACK LITE/- display option button, ADJUST/ENTER button, and LEU/PPM readout button.
Dimensions	10 in. L x 5 in. W x 6 in. H.
Weight	Approximately 5 pounds.
Case	High-impact, chemical resistant polycarbonate-polyester plastic with RF-resistant coating.
Standard Accessories	Carrying strap, hose, probe (with hydrophobic filter), dedicated sample hose with float-probe (GT 202 only), operator's manual(s)/quick reference card.
Optional Accessories	Confined space kit (CSK), dilution fitting, carrying case, extra length hose, 30 in. probe, battery chargers (220V AC, 115V AC), remote buzzer, auxiliary hydrophobic filter, and data retrieval package (5.25 and 3.50 in. diskettes, operator's manual, and associated cable).

Chapter 2

PHYSICAL DESCRIPTION

This chapter contains a description of your GT Series gas monitor. For purposes of this discussion, the GT is described as having an upper and a lower half.

EXTERNAL DESCRIPTION

All components located or typically accessed on the exterior of the GT Series gas monitor during operation are described in the following paragraphs. Figure 2-1 is an exterior view of the GT Series gas monitor.

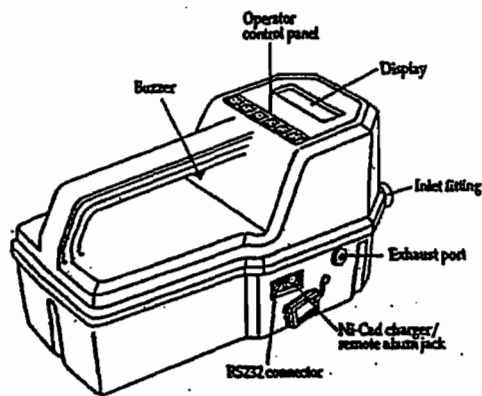

Figure 2-1 Exterior of the GT Series Gas Monitor

INSTRUCTION MANUAL
for
HORIBA MODEL PIR-2000
GENERAL PURPOSE INFRARED GAS ANALYZER
PIR-2000

HORIBA MANUAL NO. 090652 4-87

HORIBA

**INSTRUMENTS
INCORPORATED**

HORIBA INSTRUMENTS INC.
1021 DURYEA AVENUE
IRVINE INDUSTRIAL COMPLEX
IRVINE, CALIFORNIA 92714
TELEPHONE 714/250-4811

**SECTION
ONE**

GENERAL DESCRIPTION

The Horiba Model PIR-2000 General Purpose Infrared Gas Analyzer is a precision gas analyzer based on nondispersive infrared ray absorption for continuously determining the concentration of a given component in a gaseous stream.

It is designed to effectively perform continuous monitoring and component analysis in the process control industry and in various other fields such as ambient air, stationary source and vehicle exhaust emissions monitoring. It is also utilized for monitoring the simulated environment used in agricultural studies for plant growth control.

Before operating this instrument, it is recommended that the user read through this instruction manual to insure efficient operation and accurate results.

**SECTION
TWO**

SPECIFICATIONS

- Repeatability. $\pm 0.5\%$ Full Scale
- Span Drift $\pm 1\%/24$ hour Full Scale, $\pm 5^\circ\text{C}$
- Zero Drift $\pm 1\%/24$ hour Full Scale, $\pm 5^\circ\text{C}$
- Response Speed (Electrical). 0.5, 1.2, 3.0 and 5.0 seconds selectable.
1.2 seconds is standard
- Ambient Temperature. $0-40^\circ\text{C}$ (Operating temp.) -5°C to 50°C
(the drift may increase threefold between -5°C to 0°C and 40°C to 50°C . An extended operation at temp. over 40°C may shorten the service life of electrical components).
- Power Requirement. Any one of the following: 100, 115, 220, or 240 VAC, $\pm 10\%$, 50/60 Hz (to be specified)
- Output (Nonisolated) 0-10mV, 0-100mV, 0-1V, 0-5V
(Optional: 0-16mA, 4-20mA, 0-40mA, 10-50mA)
- Output (Isolated) Optional 4-20mA, 500 ohms maximum load
- Sample Gas Flow Rate 1 to 3 SCFH
- Flowing Reference Cell (Optional)
- Reference Gas Flow Rate. 1 SCFH (Approximately)
- Indicator. Scale Length: 120mm, equally divided into 100 divisions
- Range I.D. Signal. Dry contact closure. Contact rating: 100mA, DC 24V or 100mA, AC 115V
- Range Ratio. 1:10
- Ranges Three ranges, as specified from the following table:

GAS		MEASURING RANGE (Full Scale Concentration)		
		Minimum * Possible	Minimum ** Recommended	Maximum
CO	Carbon Monoxide	150 ppm	500 ppm	100%
CO ₂	Carbon Dioxide	20 ppm	200 ppm	100%
NO	Nitric Oxide	250 ppm	1000 ppm	100%
SO ₂	Sulphur Dioxide	100 ppm	400 ppm	100%
CH ₄	Methane	100 ppm	400 ppm	100%
C ₃ H ₈	Propane	100 ppm	400 ppm	100%
C ₆ H ₁₄	n-hexane	100 ppm	400 ppm	5%
NH ₃	Ammonia	300 ppm	1000 ppm	100%

SPECIAL ORDER RANGES:***

GAS		MEASURING RANGE (Full Scale Concentration)		
		Minimum * Possible	Minimum ** Recommended	Maximum
C_2H_2	Acetylene	250 ppm	1000 ppm	100%
C_2H_4	Ethylene	250 ppm	1000 ppm	100%
C_2H_6	Ethane	200 ppm	500 ppm	100%
C_2H_6O	Ethyl/alcohol	200 ppm	500 ppm	1%
C_4H_8	Butylene	200 ppm	500 ppm	100%
C_4H_{10}	Butane	200 ppm	500 ppm	100%
C_5H_{12}	Pentane	200 ppm	500 ppm	20%
C_7H_8	Toluene	200 ppm	500 ppm	10%
C_8H_{10}	Ethyl/benzene	200 ppm	500 ppm	0.2%
CH_3OH	Methanol	200 ppm	1000 ppm	3%
C_2H_3Cl	Vinyl Chloride	200 ppm	500 ppm	100%
N_2O	Nitrous Oxide	200 ppm	500 ppm	1.3%

Consult a factory engineer for specific analysis capabilities at your desired response time and noise specification.

*Minimum possible measuring range is the full scale concentration which may be measured with a signal noise of up to 2% of full scale at 5 second response time.

**Minimum Recommended Measuring Range is the full scale concentration which may be measured with a 200mm sample cell response time of 0.5 seconds full scale and a noise level of less than 0.5% of full scale.

***Instruments to measure these gases are available on special factory order only. The minimum and maximum ranges and the instrument performance specifications stated herein may be different for instruments measuring these gases depending on the specific application and other gases co-existing in the sample gas.

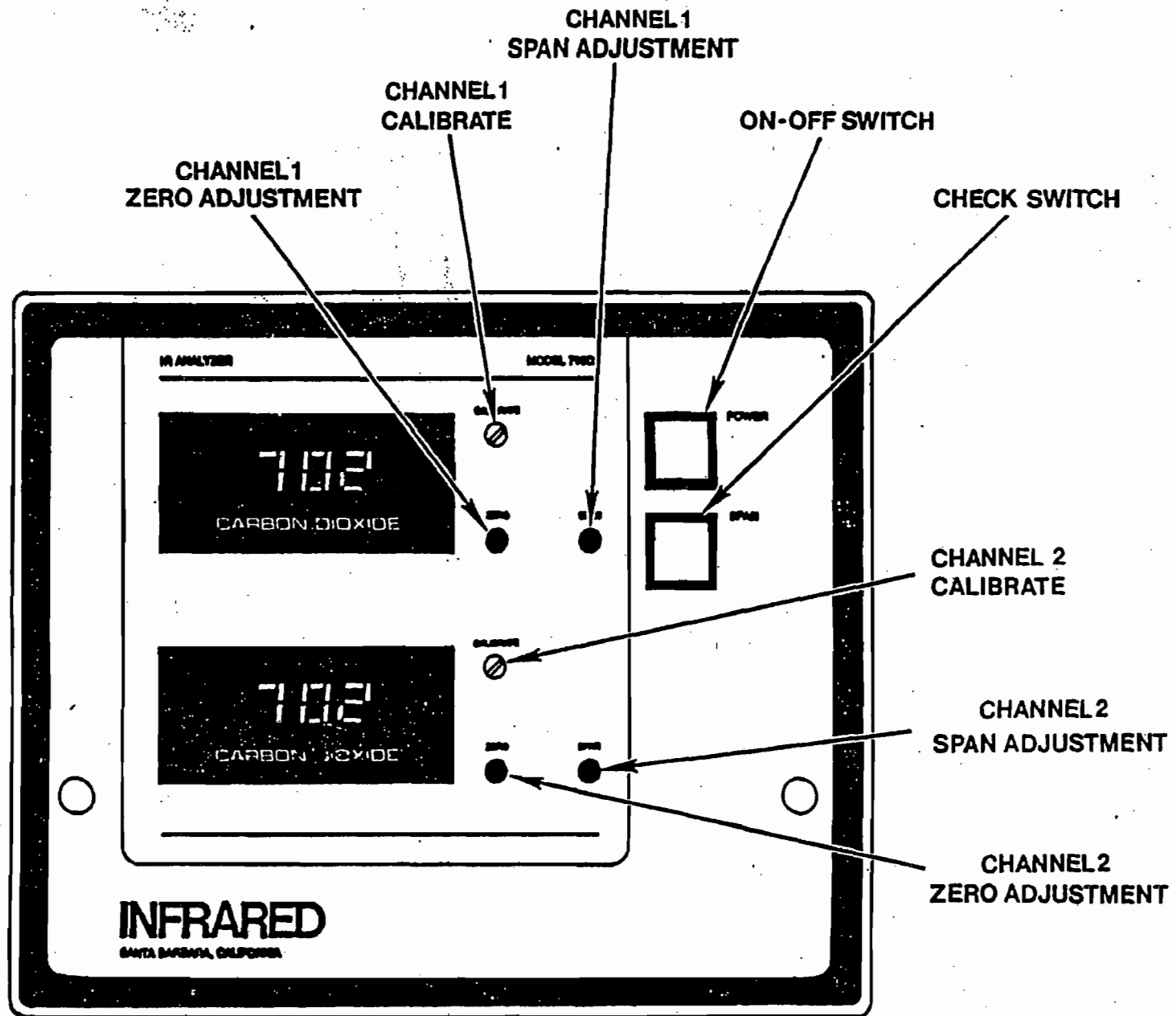

Figure 1-2

Front Panel Arrangement

SECTION II
ELECTRICAL SPECIFICATIONS

The following specifications apply to both the Model IR-702 and Model IR-703 Gas Analyzers.

Detectors	PbSe
Repeatability/accuracy ⁽¹⁾	+ 1% of full scale
Linearity	+ 0.5% of full scale
Noise Level	< 1% of full scale
Zero Drift ⁽²⁾	+ 1% of full scale/24 hours
Span Drift ⁽²⁾	+ 1% of full scale/24 hours
Standard Speed of Response	
Analog	90% of reading in 5 seconds (faster response optional)
Digital	90% of reading in 1 second
Recorder Output	0-100 mv standard 0-1 v optional others available
Power Required.	100/117/220/240 ± 10% vac, 50-60 Hz, 80 watts maximum
Operating Temperature Range	32° to 120°F (0° to 49°C)
Warm-up Time.	15 minutes

Notes:

- (1) Accuracy is dependent on absolute accuracy of the certified calibration gas.
- (2) Based on stable ambient conditions and a clean, dry sample stream regulated to a flow rate of 2-6 SCFH.

INSTRUMENT IDENTIFICATION SHEET

MODEL NUMBER: IR 2200-3052.5

SERIAL NUMBER: 4156

GAS: O₂

FULL SCALE VALUE: 1.000 10.00 25.0 %

RECORDER OUTPUT: R₂ = 100 MV

SPECIAL DATA: INTERNAL
PUMP ASS'Y PER 53472

ORIGINAL PURCHASER - TO WHICH THE ATTACHED WARRANTY IS EXTENDED:

FISHER SUPPLY CO

DATE OF ORIGINAL SHIPMENT: 12 JUNE 91

Temp (ambient) 40° to 105°F
Input Pressure 1 to 10 psig - standard limits
Flow Rate 0.3 to 3.0 scfh (Factory set at 1 scfh)
Moisture 0-100% (avoid condensation)

PERFORMANCE -

Accuracy ±2%fs is at 72°F - all ranges
Response Time 30 sec. for 90% response, 10 sec.
typical for small step change
Stability ±2%fs over 30 days typical

ELECTRICAL

Power Input 100/120/220/240 Vac 50/60 Hz -
standard
Output Signal 0 to 100 mV range - standard. Also
available 0 to 10 mV, 0 to 1V, 0 to 5V
Visual 3 1/2 digital display

GAS FLOW SYSTEM -

Gas Connection Stainless Steel, Polypropylene,
Polyethylene 1/4" tube fittings
Cell Life 6 month min, for ambient O₂ levels
longer for lower O₂ concentrations
Shelf Life 6 months storage, off load, refrigerated
in airtight package

STANDARD RANGES

Percent Analyzers 0 to 1/10/25%

General Specifications

μ R1800
Recorder

1-12 1800

The μ R1800 is a compact recorder with a recording width of 180mm. The model family consists of 1, 2, 3, 4 pen and 6, 12, 18, 24 dot model. Pen models realize continuous recording for each channel, whereas the dot-printing model realizes a high recording speed of 6dot/10sec., 12dot/15sec., 18dot/20sec., 24dot/30sec. Its input is universal, which means that it is freely selectable to use inputs like direct voltage, Thermo-couple, Resistance Temperature Detector, contact input, etc. In addition to analog recording, digital data like date & time, measured values, tags, units, scale values, chart speed, alarms, calculated values, etc. can also be printed. High reliability is realized by in house developed contact free technology, such as high breakdown voltage semiconductor relays, and DC brushless servomotors. Furthermore the μ R1800 has a short case of only 220mm. Good readability is realized by using 5x7 VFD display and its setting is made easy because of the interactive program menu. Real time data is also displayed as a bargraph. The μ R1800 can be used as a monitoring device and as a quality control instrument in many applications (such as process temperature monitoring, pollution, construction, furnaces, field of medical diagnosis, field of refrigerating, etc.).

STANDARD SPECIFICATIONS

General Specifications

Construction

Mounting:

Flush Panel Mounting (vertical)

Mounting may be inclined up to 30°, rear below front (with horizontal base).

Allowable panel thickness: 2 to 26mm

Material:

Case: drawn steel, front door: aluminium die casting.

Finish:

Case and door-frame: lamp black (Mansell 0.8Y2.5 / 0.4 or equivalent)

Door:

Splash and dust-proof (in accordance with DIN 40050-IP54).

Dimensions:

288x288x220mm (see dimensional drawings)

Weight (approx.):

1 pen	8.9kg	6 dot	9.1kg
2 pen	9.0kg	12 dot	9.4kg
3 pen	9.2kg	18 dot	9.5kg
4 pen	9.4kg	24 dot	9.6kg

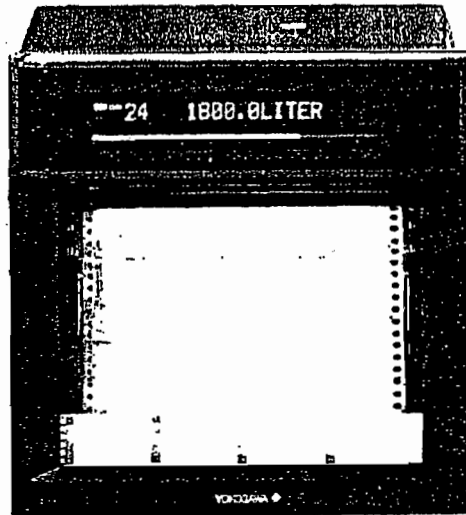

μ R1800
(24-dot model)

Model

1, 2, 3, and 4 pen, 6, 12, 18, and 24 dot-model.

Input

Inputs: DCV: Direct Current Voltage input 20mV to 20V range.

TC: Thermo couple.

RTD: Resistance Temperature Detector.

DI: Digital Input (contact or DC Voltage, TTL level).

DCA: Direct Current Input (using external shunt resistor (10 Ω , 100 Ω , 250 Ω))

Measuring range: selectable per channel

Input type	Range	Measuring Range
DC V	20mV	-20.00 to 20.00mV
	60mV	-60.00 to 60.00mV
	200mV	-200.0 to 200.0mV
	2V	-2.000 to 2.000V
	6V	-6.000 to 6.000V
	20V	-20.00 to 20.00V

Input Type	Range	Measuring Range °C	Measuring Range °F
TC	R*1	0.0 to 1760.0°C	32 to 3200°F
	S*1	0.0 to 1760.0°C	32 to 3200°F
	B*1	0.0 to 1620.0°C	32 to 3308°F
	K*1	-200.0 to 1370.0°C	-328 to 2498°F
	E*1	-200.0 to 800.0°C	-328.0 to 1472.0°F
	J*1	-200.0 to 1100.0°C	-328.0 to 2012.0°F
	T*1	-200.0 to 400.0°C	-328.0 to 752.0°F
	N*2	0.0 to 1300.0°C	32 to 2372°F
	W*3	0.0 to 2315.0°C	32 to 4198°F
	L*4	-200.0 to 900.0°C	-328.0 to 1652.0°F
U*4	-200.0 to 400.0°C	-328.0 to 752.0°F	

Input Type	Range	Measuring Range °C	Measuring Range °F
RTD	Pt100*5	-200.0 to 600.0°C	-328.0 to 1112.0°F
	JPt100*5	-200.0 to 550.0°C	-328.0 to 1022.0°F

Input Type	Range	Measuring Range
DI (Digital Input)	Voltage Input	less than 2.4V: OFF; more than 2.4V: ON(TTL)
	Contact Input	contact ON/OFF

- *1 R, S, B, K, E, J, T: ANSI, IEC 584, DIN IEC 584, JIS C 1602-1981
 *2 N: Nirosil-Nisil, IEC 584, DIN IEC 584
 *3 W: W-5%Re-W-26%Re (Hoskins Mfg Co)
 *4 L: Fe-CuNi, DIN43710 U: Cu-CuNi, DIN43710
 *5 Pt100: JIS C 1604-1989, JIS C 1606-1989, IEC 751, DIN IEC 751
 JPt100: JIS C 1604-1981, JIS C 1606-1989

Measurement Interval:

- Pen model: 125ms/channel.
 Dot printing model: 2.5s/6-, 12-, 18-, 24dot
 In case of 100ms integration:
 2.5s/6 dot, 5s/12 dot, 10s/18dot, 10s/24dot

A/D Integration Time:

- AUTO / FIX selectable
 AUTO: 20ms (50Hz) or 16.7ms (60Hz), automatically selected depending on the power supply frequency.
 FIX: 20ms (50Hz), 16.7ms (60Hz) or 100ms (50 / 60Hz) can be set.
 100ms integration time for dot printing model only

TC Burnout:

- ON/OFF selectable (per channel).
 Burnout upscale/downscale selectable (common for all channels)
 Normal: less than 2k Ω , burnout: more than 10M Ω .
 Measuring current: approx. 100nA.

Filter:

- Pen model:
 Signal damping (ON/OFF selectable per channel; in case of ON: time constant from 2, 5, 10sec).

Dot printing model:

Moving average (ON / OFF selectable per channel; in case of ON: averaging times from 2 to 16 scans).

Calculation:

Differential computation:

Between any two channels, however reference channel number. must be less than measuring channel number.

Available for DCV, TC, and RTD range.

Both channels must have same range.

Linear scaling:

Available for DCV, TC and RTD range.

Scaling limits: -20000 to 20000

Data display & printout range: -19999 to 20000

Decimal point: user selectable (should be specified when entering scale value)

Unit: user settable, up to 6 characters (alphanumerical & special characters).

Square root:

Available for DCV range.

Scaling limits: -20000 to 20000

Data display & printout range: -19999 to 20000

Decimal point: user selectable

Unit: user settable, up to 6 characters (alphanumerical & special characters).

Recording and Printing

Recording Method:

Pen model: Disposable felt pens, Plotter pen

Dot printing model: 6 color wire dot.

Pen Offset Compensation:

ON/OFF selectable (Pen model only)

Effective Recording Width: 180mm

Chart:

Plain-paper Z-fold chart (20m)

Step Response Time (pen):

Less than 1.5sec (acc. to IEC TC85 method).

Recording Period:

Pen model:

Continuous for each channel.

Dot printing model:

Max. 6 dot/10sec, 12 dot/15sec, 18 dot/20sec, 24 dot/30sec, AUTO/FIX selectable

AUTO: Analog recording interval is depending on the chart speed

FIX: Analog recording interval is set to shortest period

Chart Speed:

Pen model: 5 to 12000mm/h (82 increments)

Dot printing model: 1 to 1500mm/h (1mm step)

Chart Speed Change:

speed 1, speed 2 change by remote control signals (option).

Chart Speed Accuracy:

within $\pm 0.1\%$ (for recordings longer than 1000mm, excluding paper expansion and contraction)

**Relation between Chart Speed and Printout:
(Pen-model)**

Chart Speed	• Periodic Printout	• Alarm Printout • Message Printout • Chart Speed Change Time Printout
5 to 9mm/h	No printout	Printout
10 to 1500mm/h	Printout	Printout
1600 to 12000mm/h	No printout	No printout

(6-, 12-dot model)

Chart Speed	• Channel No. or Tag No.	• Periodic Printout	• Alarm Printout • Message Printout • Chart Speed Change Time Printout
1 to 9mm/h	Printout	No printout	Printout
10 to 100mm/h	Printout	Printout	Printout
101 to 1500mm/h	No printout	No printout	No printout

(18-, 24-dot model)

Chart Speed	• Channel No. or Tag No.	• Periodic Printout	• Alarm Printout • Message Printout • Chart Speed Change Time Printout
1 to 9mm/h	Printout	No printout	Printout
10 to 50mm/h	Printout	Printout	Printout
51 to 1500mm/h	No printout	No printout	No printout

**Relation between chart speed and printing intervals of periodic printouts:
(Pen-model)**

Chart Speed	Printing Interval of Periodic Printout
5 to 9mm/h	No printout
10 to 18mm/h	Every 8 hours
20 to 36mm/h	Every 4 hours
40 to 72mm/h	Every 2 hours
75 to 135mm/h	Every hour
150 to 180mm/h	Every 30 minutes
200 to 320mm/h	Every 20 minutes
360 to 1500mm/h	Every 10 minutes
more than 1600mm/h	No printout

(Dot-printing model)

Cart Speed	Printing Interval of Periodic Printout			
	6-dot model	12-dot model	18-dot model	24-dot model
1 to 9mm/h	No printout	No printout	No printout	No printout
10 to 18mm/h	Every 8 hours	Every 12 hours	Every 12 hours	Every 24 hours
20 to 36mm/h	Every 4 hours	Every 8 hours	Every 8 hours	Every 12 hours
40 to 50mm/h	Every 2 hours	Every 4 hours	Every 4 hours	Every 8 hours
51 to 78mm/h	Every 2 hours	Every 4 hours	No printout	No printout
80 to 100mm/h	Every hour	Every 2 hours	No printout	No printout
101 to 1500mm/h	No printout	No printout	No printout	No printout

Recording Colors:

Pen model:

pen1 = red, pen2 = green, pen3 = blue,
pen4 = violet, plotter pen = purple

Dot printing model:

ch1, 7, 13, 19 = purple, ch2, 8, 14, 20 = red,
ch3, 9, 15, 21 = green, ch4, 10, 16, 22 = blue,
ch5, 11, 17, 23 = brown, ch6, 12, 18, 24 = black
(color can be assigned to any channel)

Recording Format:

1. Analog recording:

Zone recording:

Span: More than 5mm, In 1mm steps

Partial expanded recording:

Boundary position: 1 to 99%

Boundary value: Within recording span

2. Digital printout:

Channel (dot model only):

Channel number or TAG will be printed during analog recording. Approx. every 25mm this print will occur.

Alarm:

At the right side of the chart, CH. No. or TAG, Type of alarm, ON / OFF time (h/m) will be printed. It is selectable to get ON / OFF time of alarms, or ON time, or no alarms (common for all channels).

Periodic printout:

At the left side of the chart, date (m/d), time (h/m) chart speed, and measured data of every channel will be printed.

Printing interval is INT/EXT selectable.

INT: Using internal timer. Depending on chart speed or on interval which is selectable (up to 24 hours).

EXT: Using remote control option

Channel No. or TAG printout:

Selectable, common for all channels.

Measuring printout:

ON/OFF selectable for each channel.

Scale printout:

Recording span more than 40mm, at 0% and 100% values will be printed. (When using partial expanded recording, boundary value will also be printed). ON / OFF selectable (common for all channels)

Printout of recording colors (pen model only)

Date, time and chart speed

Message printout:

Using panel key or remote control option.

Up to 5 messages.

Contents: time (h/m) and message (up to 16 characters).

Record start time:

Time (h/m) will be printed when recording starts, ON/OFF selectable

Chart speed printout:

Time (h/m) when chart speed is changed will be printed, ON/OFF selectable.

List printout:

Listings of range and alarm setting, etc. will be printed.

Manual printout:

Using panel key or remote control option. Measured values of that moment will be printed, while trend recording will be interrupted.

SET UP List printout:

Listings of settings in SET UP Mode will be printed.

Display

Display Method:

VFD (5x7 dot matrix, 20 characters).

Digital Display:

- AUTO** Channel No. or TAG No., kind of alarm, measured values, unit (when TAG No. is displayed, front 3 characters), for each channel alternately
- MANUAL** Channel No., kind of alarm, measured values, unit (when TAG No. is displayed, front 3 characters), for one specific channel
- CLOCK** Year / month / date and hour / min / sec will be displayed
- VIEW** Operating status of IC memory card will be displayed

Bargraph Display:

- Measured data** Left-referenced (%) bargraph and center zero bargraph (selectable for each channel).
- Alarm** Setting level of alarm, in case of alarm flashing display.

Alarm status display:

Channel No. will be displayed in case of alarm (dot model only)

Other Displays:

RCD: Recording in progress, POC: Pen offset compensation (pen model only), SET: Set mode, ALM: Shared alarm (not corresponding to any channel), CHT: Chart end indicator (optional), BAT: Low battery. AUTO, MAN, CLK: Display status of operation mode

Power Supply

Rated Power Voltage:

100 to 240VAC, automatically selected depending on the power supply voltage

Usable power voltage ranges:

90 to 132, 180 to 250VAC

Rated Power Frequency:

50/60 Hz, automatically selected

Power Consumption:

(approx.)

	100VAC Power Source	240VAC Power Source	Maximum
4 pen	29VA*	32VA*	70VA
6, 12, 18, 24 dot	32VA*	35VA*	55VA

* : in balance

Alarm

Number of levels:

Up to four levels for every channel (High, Low, Delta high, Delta low, High-rate-of-change, Low-rate-of-change selectable).

Interval time of rate-of-change alarm is the measuring interval times 1 to 15 (selectable, and common for both rate-of-change alarms).

Display:

Set value:

It is indicated as a point on the bargraph.

In case of an alarm:

This point will start flashing on the bargraph and the digital display will show the kind of alarm and alarm indicator in different display will show alarm.

For the dot model, the channel No. where the alarm occurred will also be displayed.

Hysteresis:

Approx. 0.5% of recording span (only High, Low alarm) and 0%, selectable (common for all channels and all levels).

Alarm indication when ALARM ACK-key is pressed:

Non-hold-type:

Alarm display is not affected when the ALARM ACK-key is pressed.

Hold-type:

When alarm occurs, alarm indicator will start flashing. After ALARM ACK-key is pressed, indicator will show status of the alarm.

Hold-type:

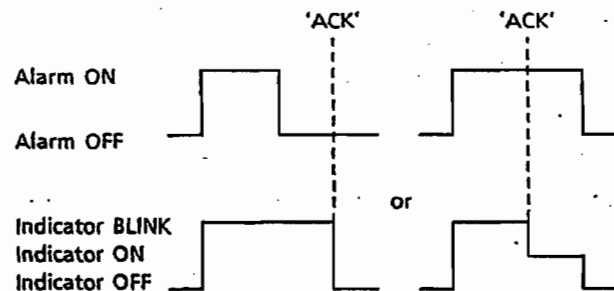

Non-hold-type:

No action will occur when ACK-key is pressed. ALM indicator depends on alarm status.

Other Specifications

Clock:

With Calendar function

Clock Accuracy:

100 PPM, however not including error due to turning ON/OFF power

Panel Key Lock:

By actual key

Internal illumination:

By using the internal reflection of VFD indicator

Memory backup:

Lithium battery to protect setting parameters.

Life is approx. ten years (at room temperature, and for standard model) and is installed inside the recorder. If the battery runs down, it will be indicated on the front panel indicator.

Insulation Resistance:

Each terminal to ground terminal: more than $20M\Omega$ (measured at 500VDC).

Dielectric Strength:

Power supply to ground terminal:

1500V AC (50/60Hz), 1 min

Contact output terminal to ground:

1500V AC (50/60Hz), 1 min

Measuring input terminal to ground:

1000V AC (50/60Hz), 1 min

Between measuring input terminals:

1000V AC (50/60Hz), 1 min

(except for RTD, since b-terminal is common).

Between remote control terminal to ground:

500V DC, 1min.

Safety Standards

In compliance to CSA 142

IEC 348

EMI Standards

In compliance to EN55011 Group 1 Class A

Normal Operating Conditions

Power voltage: 90 to 132, 180 to 250VAC

Power frequency: 50Hz $\pm 2\%$, 60Hz $\pm 2\%$

Ambient temperature: 0 to 50°C

Ambient humidity: 20 to 80% RH (at 5 to 40°C)

Vibration: 10 to 60Hz, less than 0.02G

Shock: not permissible

Magnetic field:

less than 400AT/m (DC and 50, 60Hz)

Noise:

Normal Mode (50/60Hz)

DCV Peak value including signal must be less than 1.2 times the measuring range.

TC Peak value including signal must be less than 1.2 times the measuring thermal electromotive force.

RTD less than 50mV.

Common Mode (50/60Hz)

less than 250VAC rms. for the whole range

Operating Position:

Frontwards: 0° Backwards: within 30° from horizontal

Warm-up Time:

Min 30 minutes after power has been turned ON.

THE AMERICAN GAS TURBINE METER

The American Gas Turbine Meter is an accurate, compact, ruggedly built, high volume measurement device with a variety of features to suit many applications.

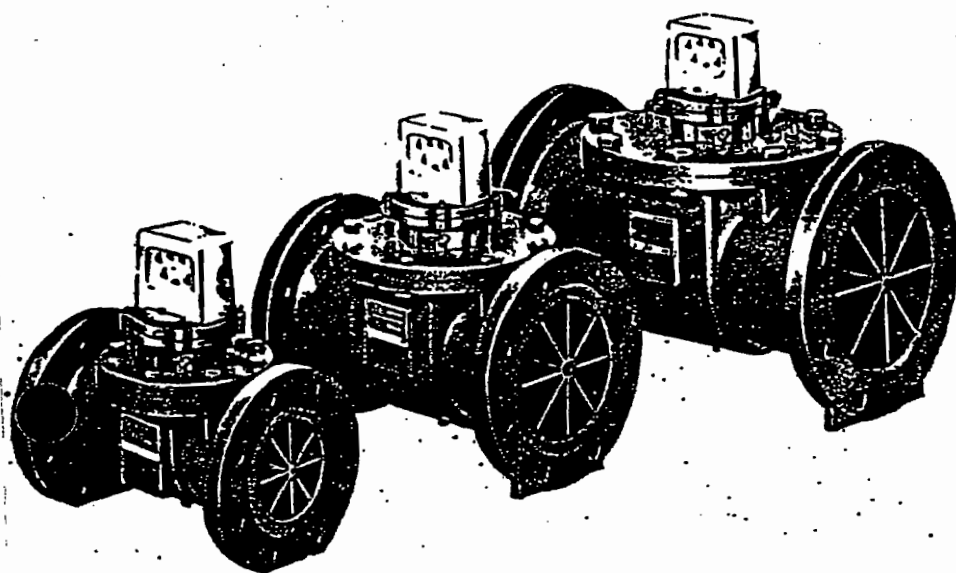

4", 6", and 8" GT

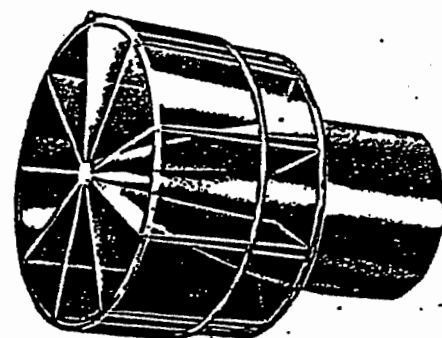

FLO-GUIDE *

Smaller station space requirements
Improved meter characteristics

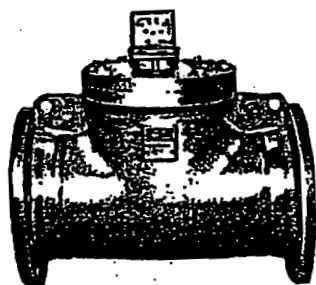

12" GT

See Bulletin 330T for complete details

A. F. BROCK & CO., INC.
4429 Hamann Parkway
Wiloughby (Cleve.), Ohio 44094
(216) 951-5959
Fax: (216) 951-1520

CAPACITIES

For gases and flowing conditions other than those shown in the table use the following equations to calculate capacities:

$$Q_{max} = Q_{min} @ 25 \text{ psig} \times \frac{P_1}{P_0}$$

$$Q_{min} = \frac{Q_{max} @ 25 \text{ psig}}{\text{Rangeability @ 25 psig}} \times \sqrt{\frac{P_1}{P_0} \times \frac{0.6}{\text{Sp. Gr.}}}$$

Q = Flow Rate—thousands of cubic feet per hour

P₁ = Flowing Pressure—psia

P₀ = Base Pressure—psia

Sp. gr. = Specific gravity of gas (air=1.0)

Maximum rated capacity at operating pressure for continuous load. Based on 1/2 SP. GR. Gas @ 60°F. and 14.73 Base Pressure.

Line Pressure PSIG	Maximum MSCFH ACT-1000	Rangeability	Maximum MSCFH 6GT-3000	Rangeability	Maximum MSCFH 6GT-6000	Rangeability
25	18	13.1:1	30	15 to 1	60	22 to 1
50	36	18.6:1	60	17.2	120	25.5
75	54	21.1:1	90	20.6	180	31.3
100	72	23.7:1	120	23.0	240	37.6
125	90	26.2:1	150	24.5	300	44.1
150	108	28.7:1	180	27.0	360	51.3
175	126	31.3:1	210	29.5	420	59.4
200	144	33.8:1	240	32.0	480	68.4
225	162	36.4:1	270	34.5	540	78.3
250	180	39.0:1	300	37.0	600	89.1
275	198	41.6:1	330	39.5	660	101.7
300	216	44.2:1	360	42.0	720	116.7
325	234	46.8:1	390	44.5	780	134.1
350	252	49.4:1	420	47.0	840	153.3
375	270	52.0:1	450	49.5	900	174.4
400	288	54.6:1	480	52.0	960	198.6
425	306	57.2:1	510	54.5	1020	226.1
450	324	59.8:1	540	57.0	1080	258.0
475	342	62.4:1	570	59.5	1140	294.6
500	360	65.0:1	600	62.0	1200	336.0
525	378	67.6:1	630	64.5	1260	382.5
550	396	70.2:1	660	67.0	1320	434.4
575	414	72.8:1	690	69.5	1380	492.0
600	432	75.4:1	720	72.0	1440	555.6
625	450	78.0:1	750	74.5	1500	626.4
650	468	80.6:1	780	77.0	1560	704.4
675	486	83.2:1	810	79.5	1620	789.6
700	504	85.8:1	840	82.0	1680	882.0
725	522	88.4:1	870	84.5	1740	981.6
750	540	91.0:1	900	87.0	1800	1098.0
775	558	93.6:1	930	89.5	1860	1231.2
800	576	96.2:1	960	92.0	1920	1382.4
825	594	98.8:1	990	94.5	1980	1551.6
850	612	101.4:1	1020	97.0	2040	1749.6
875	630	104.0:1	1050	99.5	2100	1976.8
900	648	106.6:1	1080	102.0	2160	2283.6
925	666	109.2:1	1110	104.5	2220	2671.2
950	684	111.8:1	1140	107.0	2280	3140.4
975	702	114.4:1	1170	109.5	2340	3692.4
1000	720	117.0:1	1200	112.0	2400	4337.6
1025	738	119.6:1	1230	114.5	2460	5076.0
1050	756	122.2:1	1260	117.0	2520	5908.8
1075	774	124.8:1	1290	119.5	2580	6846.0
1100	792	127.4:1	1320	122.0	2640	7988.4
1125	810	130.0:1	1350	124.5	2700	9346.8
1150	828	132.6:1	1380	127.0	2760	10932.0
1175	846	135.2:1	1410	129.5	2820	12754.8
1200	864	137.8:1	1440	132.0	2880	14824.8
1225	882	140.4:1	1470	134.5	2940	17162.4
1250	900	143.0:1	1500	137.0	3000	19778.4
1275	918	145.6:1	1530	139.5	3060	22683.6
1300	936	148.2:1	1560	142.0	3120	25988.4
1325	954	150.8:1	1590	144.5	3180	29703.6
1350	972	153.4:1	1620	147.0	3240	33839.2
1375	990	156.0:1	1650	149.5	3300	39405.6
1400	1008	158.6:1	1680	152.0	3360	46512.0
1425	1026	161.2:1	1710	154.5	3420	55268.4
1450	1044	163.8:1	1740	157.0	3480	65785.2
1475	1062	166.4:1	1770	159.5	3540	78172.8
1500	1080	169.0:1	1800	162.0	3600	92541.6
1525	1098	171.6:1	1830	164.5	3660	109001.6
1550	1116	174.2:1	1860	167.0	3720	127762.8
1575	1134	176.8:1	1890	169.5	3780	149035.2
1600	1152	179.4:1	1920	172.0	3840	173018.4
1625	1170	182.0:1	1950	174.5	3900	199922.4
1650	1188	184.6:1	1980	177.0	3960	230058.0
1675	1206	187.2:1	2010	179.5	4020	263734.8
1700	1224	189.8:1	2040	182.0	4080	301362.0
1725	1242	192.4:1	2070	184.5	4140	343348.8
1750	1260	195.0:1	2100	187.0	4200	390006.0
1775	1278	197.6:1	2130	189.5	4260	442744.8
1800	1296	200.2:1	2160	192.0	4320	502086.0
1825	1314	202.8:1	2190	194.5	4380	568551.6
1850	1332	205.4:1	2220	197.0	4440	642763.2
1875	1350	208.0:1	2250	199.5	4500	725341.6
1900	1368	210.6:1	2280	202.0	4560	816907.2
1925	1386	213.2:1	2310	204.5	4620	918072.0
1950	1404	215.8:1	2340	207.0	4680	1030447.2
1975	1422	218.4:1	2370	209.5	4740	1154744.4
2000	1440	221.0:1	2400	212.0	4800	1292572.8

The above table is based on approximately constant index rates. Supercompressibility is not included.

TURBINE METER DIMENSIONS

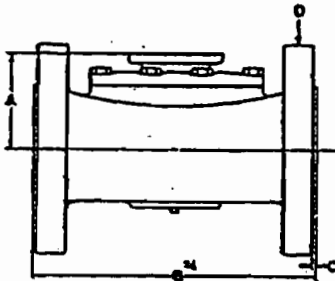

Size	Working Pressure	Shipping Weight in lbs. (approx.)	A	B	C	O - FLANGE DIAMETER			
						O.S.	B.C.	Solt Holes	
								No.	Size
4-inch (1000 lb. shell)	175	22	5	14	None	8	7 7/8	8	8
	300*	66	5	14	1/16	10	7 7/8	8	8
	575*	150	5	14	1/16	10	7 7/8	8	8
	720*	150	5	14	1/16	10	7 7/8	8	8
6-inch (1000 lb. shell)	175	54	6	16	None	11	10 1/2	12	12
	300*	160	6	16	1/16	12 1/2	10 1/2	12	12
	575*	315	6	16	1/16	12 1/2	10 1/2	12	12
	720*	315	6	16	1/16	12 1/2	10 1/2	12	12
8-inch (1000 lb. shell)	175	90	7 1/2	21	None	13 1/2	13 1/2	16	16
	300*	290	7 1/2	21	1/16	15 1/2	13 1/2	16	16
	575*	520	7 1/2	21	1/16	15 1/2	13 1/2	16	16
	720*	450	7 1/2	21	1/16	15 1/2	13 1/2	16	16

* ANSI 300 Flanges
- ANSI 600 Flanges

CHARACTERISTIC PERFORMANCE CURVE
ACCURACY VERSUS FLOW RATE

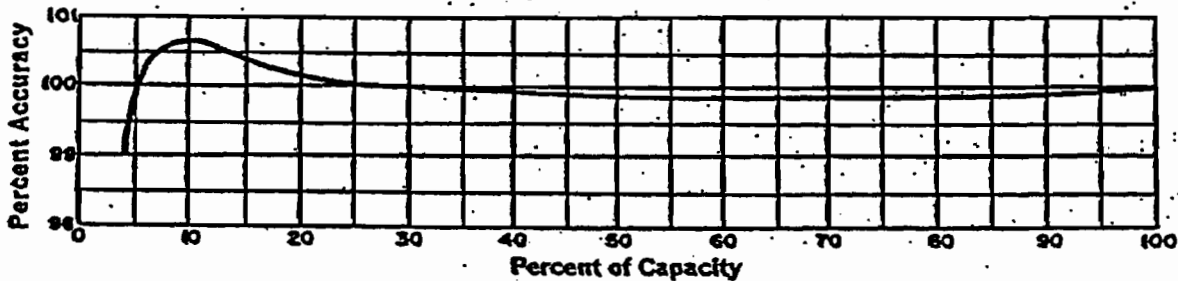

RATED CAPACITY AT OPERATING PRESSURE, 14.73 psia BASE PRESSURE, 14.73 psia ATMOSPHERIC PRESSURE

Line Pressure (psig)	12 GT-125			12 GT-220			12 GT-3440		
	Flow MSCFH		Rangeability Ratio	Flow MSCFH		Rangeability Ratio	Flow MSCFH		Rangeability Ratio
	Maximum	Minimum		Maximum	Minimum		Maximum	Minimum	
0.25 (4oz)	150	6.0	25:1	150	6.0	25:1	150	8.3	18:1
50	652	12.5	52:1	652	12.5	52:1	652	17.4	37:1
100	1153	16.6	69:1	1153	16.6	69:1	1153	23.2	50:1
125	1313	18.4	71:1	1313	18.4	71:1	1313	25.3	52:1
250	—	—	—	2658	25.3	104:1	2658	35.2	75:1
500	—	—	—	5167	35.4	146:1	5167	49.3	106:1
720	—	—	—	7492	42.1	177:1	7492	64.0	117:1
1000	—	—	—	—	—	—	10333	69.3	149:1
1440	—	—	—	—	—	—	14814	82.9	178:1

The above table is based on approximately constant index rates. Supercompressibility is not included. RANGEABILITY is the ratio of the maximum rated capacity to the minimum capacity within ±1% of 100% accuracy. Rangeability ratios in the table above are based on natural gas — 0.60 sp. gr.

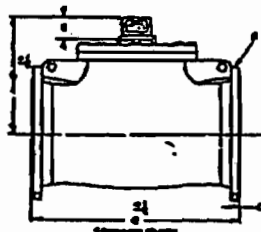

F, Standard Index 4 1/2-inches

Model (Maximum Working Pressure (psig))	Body Dimensions - inches			Flange Dimensions - inches		Solt	
	A	B	C	D		No.	Size - inches
				O.S.	B.C.		
175	19 1/4	25	1 1/16	19	17	12	1 1/2
720	20 1/4	30 1/2	1 1/16	20 1/4	17 1/2	16	1 1/2
1440	20 1/4	32 1/2	1 1/4	22	19 1/2	20	1 1/2

O.S. - Outside Diameter B.C. - Bolt Circle Diameter
* Includes Standard Index

Meter Designation

8" GT 175#

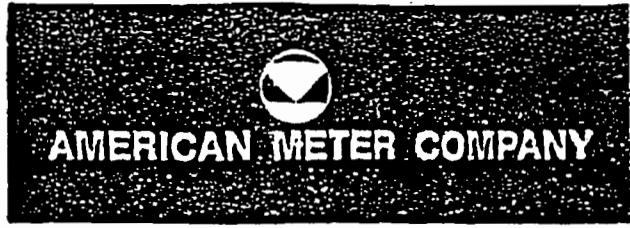

Manufacturer's Number
90-52587

Cartridge Number
P-40426

AMERICAN GAS TURBINE METER

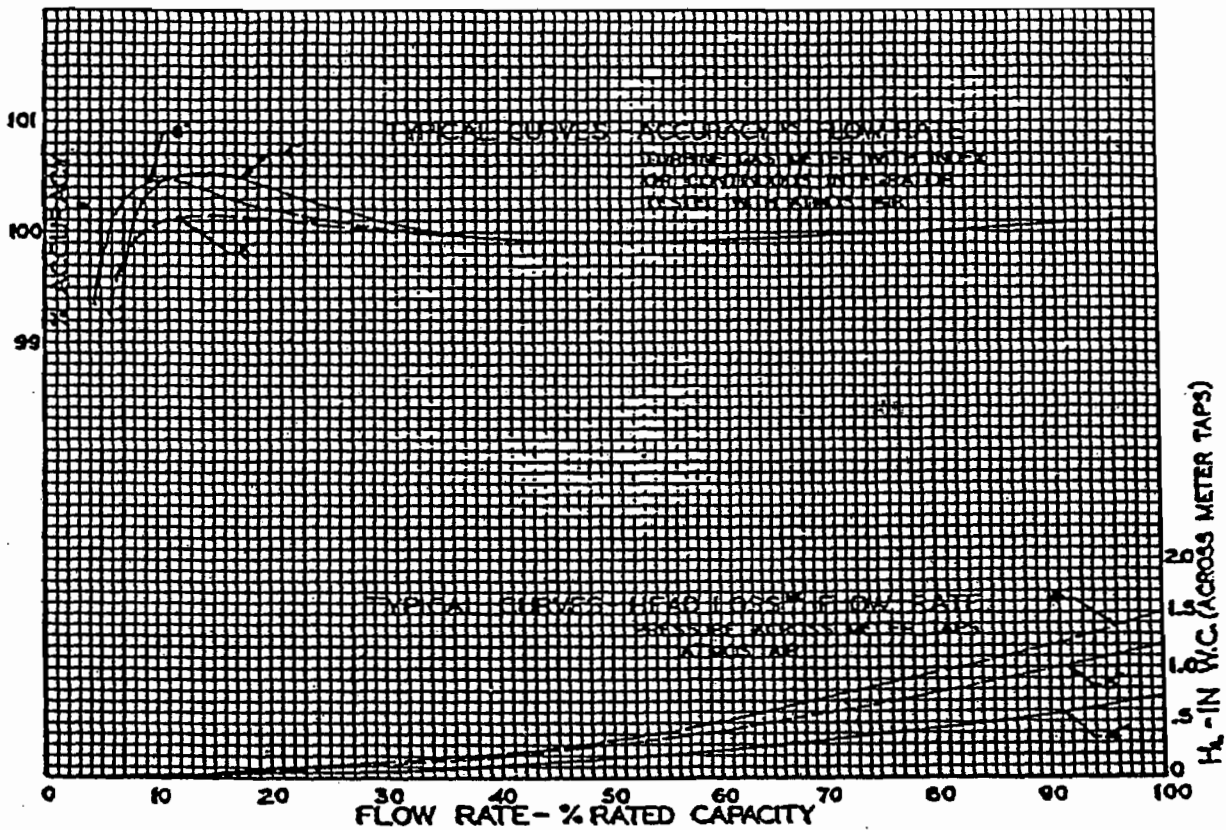

Chge. gears: 47/63 (54548G005)

FLOW RATE (AIR) SCFH	% ACCURACY	DIFFERENTIAL (inches H ₂ O) Tested on air
38,500	99.9	0.2
8,000	100.9	.0
3,000	100.6	.0

Test Trailer Turbine Meter Calibration

CALCULATE: The Test Meter Calibration Coefficient.

$$Y_m = \frac{Q_{sd}}{Q_{sd_{act}}} \quad \text{Eq. 2A-1}$$

$Y_m = \quad 0.97946953 \quad 0.987433 \quad 0.96241981$ All meter coefficients must be between 0.95 and 1.05.

DETERMINE: The Minimum and Maximum Coefficients.

Maximum Value: 0.987433

Minimum Value: 0.96241981

Difference: 0.02501319 Must not exceed 0.030

CALCULATE: The Average Test Meter Calibration Coefficient Value:

Avg $Y_m =$ Sum of three Y_m Values / 3

Avg $Y_m = \quad 0.97644078$ This value gets entered into computer program for test trailer constants.

CALIBRATE: The Test Trailer Temperature Thermistors

Reference Thermometer:
Fisher: 885-250
ID 15041D

	Actual Reading (Deg. C)	Reference Reading (Deg. C)	Percent Difference	Allowable
Flow Temperature Thermistor	22.3	22.2	0.44843049	+/- 2.0 %
Ambiant Temperature Thermistor	22.1	22.2	-0.45248869	+/- 2.0 %

CALIBRATE: The Test Trailer Barometer

Trailer Barometer: Setra: Model 2270 Manometer
Reference Barometer: Princo - NOVA

	Actual Reading (mm Hg)	Reference Reading (mm Hg)	Difference	Allowable
Barometric Reading	763.5	764.2	-0.7	+/- 2.5 mm Hg

CALIBRATE: Flow Pressure Transducer

Trailer Flow Transducer: Setra Model: 264
Reference: Water Slack Tube Monometer

	Actual Reading (mm Hg)	Reference Reading (mm Hg)	Difference	Allowable
Flow Pressure Reading	2.4	2.5	-0.1	+/- 2.5 mm Hg
	9.9	10	-0.1	+/- 2.5 mm Hg

Test Trailer Turbine Meter Calibration

September 4, 2001

Trailer 1

Meter:

40426

**40 CFR 60 METHOD 2A
PITOT TUBE VELOCITY AND FLOW RATE CALIBRATION FOR 8" TURBINE
SIX MONTH FULL CALIBRATION CHECK**

DEFINITIONS:

M_a = Mol. wt. of Air (lb/lb-mole)
 v_s = Duct gas velocity (ft/sec)
 Q_{sd} = Std. dry volumetric duct flow rate (dscf/hr)
 K_p = Pitot tube constant
 C_p = Pitot tube coefficient (dimensionless)
 Δp = Velocity head of stack gas (in H_2O)

T_s = Absolute avg. stack gas temperature ($^{\circ}K$)
 T_{std} = Standard temperature (20 $^{\circ}C$ or 68 $^{\circ}F$)
 P_s = Absolute duct pressure (in Hg.)
 P_{std} = Standard pressure (in Hg.)
 P_{bar} = Barometric pressure (mm Hg.)
 A = Cross sectional area of duct (ft^2)

DATA INPUT: please enter the following data using correct units;

	<u>30 % Flow</u>	<u>60 % Flow</u>	<u>90 % Flow</u>	
Δp =	0.064	0.21	0.38	in. H_2O (from pitot tube)
T_s =	22.3	22.3	22.4	$^{\circ}C$ (from thermister/thermometer)
P_g =	0.9	2	2.4	in H_2O (from trailer pressure transducer)
***** P_g =	1.681488	3.73664	4.483968	mm Hg (calculated)
P_{bar} =	763.5	763.5	763.5	mm Hg (from barometer)
Dia =	7.875	7.875	7.875	In I.D.
***** A =	0.33824248	0.33824248	0.33824248	ft^2 (calculated from above)

CORRECTED DATA/CONSTANTS USED IN FORMULAS:

	<u>30 % Flow</u>	<u>60 % Flow</u>	<u>90 % Flow</u>	
T_{std} =	528	528	528	$^{\circ}K$
T_s =	532.14	532.14	532.32	$^{\circ}K$
P_{std} =	29.92	29.92	29.92	in. Hg
P_{bar} =	30.0590551	30.0590551	30.0590551	in. Hg
P_s =	30.1252554	30.2061669	30.2355893	in. Hg
M_a =	28.9644	28.9644	28.9644	lb/lb-mole (from Mark's M.E. Handbook)
C_p =	0.99	0.99	0.99	Dimensionless
K_p =	85.49	85.49	85.49	$\frac{ft^2(lb/lb-mole)(in. Hg)^{1/2}}{sec^2 (^{\circ}R) (in. H_2O)}$

CALCULATE: Average duct gas velocity

$$v_s = K_p \cdot C_p \cdot [(\Delta p)^{1/2}] \cdot [(T_s / (P_s \cdot M_a))^{1/2}] \quad \text{Eq. 2.9}$$

	<u>30 % Flow</u>	<u>60 % Flow</u>	<u>90 % Flow</u>	
v_s =	16.7207523	30.2477472	40.6759041	(ft/sec)
=	1003.24514	1814.86483	2440.55425	(ft/min)
=	305.867421	553.312448	744.071417	(m/min)

CALCULATE: Average duct gas volumetric flow rate

$$Q_{sd} = 3600 \cdot v_s \cdot A \cdot [(T_{std} \cdot P_s) / (T_s \cdot P_{std})] \quad \text{Eq. 2.10}$$

	<u>30 % Flow</u>	<u>60 % Flow</u>	<u>90 % Flow</u>	
Q_{sd} =	20340.5939	36894.8483	49646.1814	(scf/hr)
=	339.009898	614.914138	827.436357	(scf/min)
=	2535.97032	4599.87751	6189.65422	(gal/min)
=	9.6007603	17.4143684	23.4329976	(meters ³ /min)
=	48.0038015	87.0718419	117.164988	(meter ³ /5 min.)

INPUT: Average Ves Values from 5-minute Test Data Printouts.

$Q_{sd_{act}}$ =	49.01	88.18	121.74	(cubic meters)
------------------	-------	-------	--------	----------------

APPENDIX C

COMPUTER PRINTOUT LEGEND

AMBIENT-T.....Ambient Temperature.....° Celsius
EXHAUST-T..... Exhaust Temperature.....° Celsius
EXHAUST-P.....Exhaust Pressure.....mm Hg
BARO-P.....Barometric Pressure.....mm Hg
HCin.....Inlet VOC Concentration (when used).....% by volume
HCout.....Exhaust VOC Concentration.....Vol. Fraction
VES.....Flow Through Turbine Meter.....m³ std.
ME.....Total Milligrams Emitted.....mg of VOC
VE.....Flow Through Turbine Meter.....m³



John Jordan Service Company
Technical Services Group
502 267-8344

Vapor Recovery Performance Test

Test Id: 000694123-00057

Test for: Motiva Enterprise LLC North
Fort Lauderdale, FL

Unit Tested: John Zink VRU

Test Date: 02/21/2002

Test Personnel: Tony Fenton
Glen Toloczko

Strip Chart Recorder Speed: 150

All data fields are rounded 2 places following the decimal for display purposes. Internal to the program all data fields are 8 digits following the decimal.

Outlet Calibration Information

Allowable range is +/- 5% of actual span gas Concentration

Low range span gas concentration	2.53 %, Cylinder # FF-32443
Mid range span gas concentration	4.50 %, Cylinder # FF-34566
High range span gas concentration	9.09 %, Cylinder # FF-20107
Zero span analyzer reading	0.00 %
Zero range analyzer error	0.00 %
Low range analyzer reading	2.56 %
Low range analyzer error	1.19 %
Mid range analyzer reading	4.42 %
Mid range analyzer error	-1.78 %
High range analyzer reading	9.07 %
High range analyzer error	-0.22 %

Inlet Calibration Information

Allowable range is +/- 5% of actual span gas Concentration

Low range span gas concentration	25.11 %, Cylinder # LL-36178
Mid range span gas concentration	49.84 %, Cylinder # LL-25095
High range span gas concentration	84.08 %, Cylinder # LL-36180
Zero span analyzer reading	0.01 %
Zero range analyzer error	0.00 %
Low range analyzer reading	24.63 %
Low range analyzer error	-1.91 %
Mid range analyzer reading	49.05 %
Mid range analyzer error	-1.59 %
High range analyzer reading	83.97 %
High range analyzer error	-0.13 %

Time	Baro-P mm Hg	Exhaust-P mm Hg	Ambient-T Deg C	Exhaust-T Deg C	HCIn %	HCOut %	VE mtr ³	VES mtr ³	ME mg
08:21	763.18	0.00	23.31	24.12	68.66	1.67	0.02	0.02	556.03
08:26	763.13	0.00	23.58	24.21	80.20	0.40	1.80	1.78	11334.91
08:31	763.15	0.00	24.04	24.33	86.31	0.52	0.01	0.01	120.08
08:36	763.23	0.00	24.62	24.24	75.99	0.60	0.00	0.00	6.12
08:41	763.35	0.03	24.82	24.32	69.07	0.67	0.00	0.00	2.23
08:46	763.41	0.08	24.62	24.53	79.21	0.08	2.51	2.48	3174.49
08:51	763.47	0.00	24.33	24.42	79.62	0.10	0.00	0.00	0.78
08:56	763.54	0.00	24.58	24.35	70.42	0.11	0.00	0.00	1.02
09:01	763.51	0.05	24.85	24.53	78.20	0.04	2.10	2.07	1203.59
09:06	763.51	0.12	24.89	24.78	80.75	0.05	0.51	0.50	490.37
09:11	763.54	0.08	24.81	24.55	73.30	0.06	0.00	0.00	0.33
09:16	763.72	0.00	24.89	24.55	70.73	0.08	0.00	0.00	0.14
09:21	763.89	0.00	24.98	25.01	79.55	0.02	3.10	3.06	1099.02
09:26	763.87	0.00	25.05	24.89	75.99	0.02	0.00	0.00	0.12
Outlet Span check completed at 09:27 the reading is: 4.39 % Allowable: 4.12 thru 4.72									
Outlet Zero check completed at 09:29 the reading is: 0.00 % Allowable: -0.30 thru 0.30									
Outlet Span check completed at 09:30 the reading is: 48.88 % Allowable: 46.05 thru 52.05									
Inlet Zero check completed at 09:31 the reading is: 0.49 % Allowable: -2.99 thru 3.01									
09:31	763.93	0.00	25.19	24.84	50.20	0.05	0.00	0.00	0.08
09:36	763.89	0.04	25.28	25.07	76.61	0.01	2.48	2.45	267.43
09:41	763.92	0.00	25.44	25.37	81.84	0.01	0.56	0.55	113.46
09:46	763.88	0.00	25.75	25.16	52.12	0.02	0.00	0.00	0.06
09:51	763.90	0.03	26.21	26.43	60.50	0.14	7.31	7.18	18976.82
09:56	763.95	0.12	26.34	27.00	65.33	0.06	10.89	10.68	9613.72
10:01	763.94	0.12	26.30	26.92	71.13	0.18	7.47	7.33	24263.62
10:06	764.00	0.12	26.26	26.97	64.46	0.41	7.54	7.40	57266.46
10:11	764.09	0.12	26.41	27.47	67.46	0.31	9.28	9.09	47195.90
10:16	764.20	0.12	26.55	27.52	59.94	0.21	6.71	6.57	25764.94
10:21	764.27	0.12	26.49	27.31	68.92	0.35	5.94	5.83	36519.31
10:26	764.26	0.12	26.13	26.98	74.44	0.54	5.48	5.38	51382.63
10:31	764.30	0.12	25.96	27.15	75.63	0.20	8.11	7.96	23938.47
10:36	764.26	0.02	25.92	27.02	47.78	0.67	1.59	1.56	19840.86
Outlet Span check completed at 10:38 the reading is: 4.40 % Allowable: 4.12 thru 4.72									
Outlet Span check completed at 10:40 the reading is: 49.48 % Allowable: 46.05 thru 52.05									
Outlet Zero check completed at 10:40 the reading is: 0.02 % Allowable: -0.30 thru 0.30									
Inlet Zero check completed at 10:41 the reading is: 0.72 % Allowable: -2.99 thru 3.01									
10:41	764.18	0.00	26.05	27.23	80.03	1.37	4.88	4.78	119812.58

Time	Baro-P mm Hg	Exhaust-P mm Hg	Ambient-T Deg C	Exhaust-T Deg C	HCIn %	HCOut %	VE mtr ³	VES mtr ³	ME mg
10:46	764.15	0.10	26.58	27.92	75.95	0.70	8.08	7.91	60025.18
10:51	764.09	0.11	26.68	27.83	73.55	0.51	9.43	9.23	84729.35
10:56	763.99	0.12	26.42	27.55	72.34	1.05	8.14	7.97	149810.39
11:01	763.93	0.09	26.28	27.18	76.57	0.79	0.24	0.24	454.03
11:06	763.90	0.00	26.54	27.40	83.22	0.12	1.77	1.74	3461.81
11:11	763.89	0.00	26.91	26.97	0.00	0.00	0.00	0.00	0.00
Outlet Span check completed at 11:16 the reading is: 4.43 % Allowable: 4.12 thru 4.72									
11:16	763.87	0.00	27.11	26.82	58.93	0.14	0.00	0.00	0.70
Inlet Span check completed at 11:18 the reading is: 49.33 % Allowable: 46.05 thru 52.05									
Outlet Zero check completed at 11:18 the reading is: 0.01 % Allowable: -0.30 thru 0.30									
Inlet Zero check completed at 11:19 the reading is: 0.67 % Allowable: -2.99 thru 3.01									
11:21	763.91	0.04	27.16	27.05	79.05	0.09	2.45	2.40	3533.46
11:26	763.90	0.02	26.84	27.08	82.10	0.13	0.17	0.16	379.71
11:31	763.85	0.00	26.71	26.76	70.31	0.14	0.00	0.00	0.30
11:36	763.78	0.00	26.63	26.77	77.13	0.05	0.61	0.59	278.99
11:41	763.75	0.06	26.42	27.07	82.94	0.04	2.06	2.02	1508.69
11:46	763.64	0.00	26.24	26.72	76.85	0.05	0.00	0.00	0.49
11:51	763.57	0.00	26.16	26.62	77.34	0.05	0.00	0.00	0.35
11:56	763.55	0.07	26.56	27.24	81.64	0.03	2.85	2.79	1368.83
12:01	763.51	0.09	26.94	27.84	81.05	0.08	2.48	2.42	3926.39
12:06	763.47	0.12	27.00	28.24	76.82	0.23	4.57	4.47	18696.79
12:11	763.38	0.12	26.85	28.15	76.16	0.28	5.73	5.60	24342.03
12:16	763.30	0.10	26.62	28.24	75.75	0.08	6.01	5.87	6651.68
12:21	763.26	0.05	26.56	28.21	48.86	0.02	0.10	0.10	33.69
Outlet Span check completed at 12:26 the reading is: 4.42 % Allowable: 4.12 thru 4.72									
12:26	763.19	0.11	26.71	28.79	0.00	0.00	0.00	0.00	0.00
Inlet Span check completed at 12:29 the reading is: 48.84 % Allowable: 46.05 thru 52.05									
Outlet Zero check completed at 12:29 the reading is: 0.03 % Allowable: -0.30 thru 0.30									
Inlet Zero check completed at 12:30 the reading is: 48.95 0.64 % Allowable: -2.99 thru 3.01									
12:31	763.19	0.01	26.75	28.66	0.00	0.00	0.00	0.00	0.00
12:36	763.12	0.00	26.59	28.03	0.00	0.00	0.00	0.00	0.00
12:41	763.02	0.00	26.51	27.51	0.00	0.00	0.00	0.00	0.00
12:46	762.95	0.00	26.47	27.28	0.00	0.00	0.00	0.00	0.00
12:51	762.90	0.00	26.51	27.78	0.00	0.00	0.00	0.00	0.00
12:56	762.84	0.00	26.48	27.47	0.00	0.00	0.00	0.00	0.00
13:01	762.77	0.00	26.60	27.30	0.00	0.00	0.00	0.00	0.00
13:06	762.74	0.06	26.92	27.72	85.57	0.02	0.48	0.47	213.80

Time	Baro-P mm Hg	Exhaust-P mm Hg	Ambient-T Deg C	Exhaust-T Deg C	HCIn %	HCOut %	VE mtr ³	VES mtr ³	ME mg
13:11	762.65	0.12	27.33	27.96	85.67	0.03	0.18	0.18	84.81
13:16	762.59	0.10	27.54	27.58	0.54	0.03	0.00	0.00	0.02
Inlet Span check completed at 13:18 the reading is: 85.26 % Allowable: 46.05 thru 52.05									
Inlet Zero check completed at 13:18 the reading is: 95.26 % Allowable: -2.99 thru 3.01									
Outlet Span check completed at 13:21 the reading is: 4.40 % Allowable: 4.12 thru 4.72									
13:21	762.50	0.00	27.34	27.52	69.24	0.03	0.27	0.26	75.54
Inlet Span check completed at 13:23 the reading is: 49.76 % Allowable: 46.05 thru 52.05									
Outlet Zero check completed at 13:23 the reading is: 0.02 % Allowable: -0.30 thru 0.30									
Inlet Zero check completed at 13:24 the reading is: 0.54 % Allowable: -2.99 thru 3.01									
13:26	762.49	0.00	27.33	28.53	82.38	0.03	2.90	2.83	1486.00
13:31	762.45	0.00	27.38	29.03	64.65	0.15	3.94	3.83	10347.25
13:36	762.41	0.10	27.35	29.48	69.58	0.17	5.97	5.80	17481.85
13:41	762.38	0.12	27.36	29.74	69.66	0.10	7.70	7.47	10277.04
13:46	762.36	0.12	27.34	29.31	69.47	0.13	5.94	5.77	13855.52
13:51	762.36	0.03	27.17	28.89	69.45	0.18	5.00	4.87	15709.28
13:56	762.35	0.05	27.13	28.86	68.91	0.29	7.26	7.06	36106.53
14:01	762.27	0.12	27.14	29.35	74.31	0.10	6.35	6.17	8420.57
14:06	762.24	0.02	27.27	28.78	79.96	0.15	0.00	0.00	9.82
14:11	762.23	0.00	27.42	28.58	0.21	0.01	0.00	0.00	0.04
14:16	762.15	0.00	27.42	28.58	0.08	0.01	0.01	0.01	2.33
Inlet Span check completed at 14:22 the reading is: 48.97 % Allowable: 46.05 thru 52.05									
Inlet Zero check completed at 14:25 the reading is: 0.21 % Allowable: -2.99 thru 3.01									
Outlet Span check completed at 14:26 the reading is: 4.39 % Allowable: 4.12 thru 4.72									
Outlet Zero check completed at 14:30 the reading is: 0.01 % Allowable: -0.30 thru 0.30									

Preliminary Test Results

The test id is 000694123-00057

There were 72 test intervals, 63 of which had flow.

Average Barometric Pressure:	763.39 mm Hg
Average Flow Pressure:	0.05 mm Hg
Average Ambient Temperature:	26.24 celcius
Average Exhaust Temperature:	26.97 celcius
Average Inlet Concentration:	60.84 %
Average Outlet Concentration:	0.21 %
Total Volume Emitted:	188.97 cubic meters
Total Standardized Volume Emitted:	184.92 cubic meters
Total milli-grams Emitted:	926218.78
Accountable Gallons Loaded:	184590.0
Total Gallons Loaded:	193295.0
Accountable Liters Loaded:	698748.83
Total Liters Loaded:	731700.83
Accountable milli-grams Emitted per Liter Loaded:	1.33
Total milli-grams Emitted per Liter Loaded:	1.27
Unit Efficiency for Accountable Gas Loaded:	99.88
Unit Efficiency for Total Gas Loaded:	99.89

APPENDIX F

MONTHLY LEAK INSPECTION FORM

Motiva Enterprises, LLC South Florida Complex
Fort Lauderdale, Florida 33316

The South Florida Complex, consists of three terminals.

The North Terminal, the South Terminal, and the East Terminal.

Use this form to check and document the monthly tests for vapor leaks, I.E. Internal floating roofs, external floating roofs, and vapor lines from the vapor unit to the loading racks, I.E., vapor combustor, vapor bladder tank, and the Flame arrestor.

Tank number: Terminal: Date:

Vapor lines checked: Terminal: Date:

Comments:

Date:

Signed: _____

APPENDIX G

ENGINEERING EMISSION ANALYSIS TEST RESULTS

cem003.wk4

VRU Emissions and Efficiency from CEM Data
Estimated Calculations

input
calcs
alternate

Use One Truck Load as the Basis for all Calculations

Truck Volume =	9,000	gals	
HC vol% in =	30	vol %	359.088576
HC vol% out =	0.02	vol %	379.4308943
Purge Air Volume Fraction =	0.1	NOTE: this is variable	
Propane Calibration Gas Density =	7	gm/gal	6.946560792
Butane Calibration Gas Density =	9.2	gm/gal	9.156221499

HC Mass In = 9000 gal x 30 % HC x 7 gm/gal
= 18,900 gm

HC Mass Out = ((9000 gal x (1-30%HC)) + (9000 x 0.1)) x 0.02%HC x 7 gm/gal
= 10 gm

mg/liter unit conversion = HC mass out x 1000 mg/gm x 1/9000 gal x 1/3.785 liter/gal
= 0.30 mg/liter

Efficiency calculation = (HC mass in - HC Mass out)/HC Mass in x 100%
= 99.95 %

HC In vol %
HC out vol %

20	efficiency	mg/liter	25	efficiency	mg/liter	30	efficiency	mg/liter	35	efficiency	mg/liter
0.1	99.55	1.66	0.1	99.66	1.57	0.1	99.73	1.48	0.1	99.79	1.39
0.2	99.10	3.33	0.2	99.32	3.14	0.2	99.47	2.96	0.2	99.57	2.77
0.3	98.65	4.99	0.3	98.98	4.72	0.3	99.20	4.44	0.3	99.36	4.16
0.4	98.20	6.66	0.4	98.64	6.29	0.4	98.93	5.92	0.4	99.14	5.55
0.5	97.75	8.32	0.5	98.30	7.86	0.5	98.67	7.40	0.5	98.93	6.94
0.6	97.30	9.99	0.6	97.96	9.43	0.6	98.40	8.88	0.6	98.71	8.32
0.7	96.85	11.65	0.7	97.62	11.00	0.7	98.13	10.36	0.7	98.50	9.71
0.8	96.40	13.32	0.8	97.28	12.58	0.8	97.87	11.84	0.8	98.29	11.10
0.9	95.95	14.98	0.9	96.94	14.15	0.9	97.60	13.32	0.9	98.07	12.48
1	95.50	16.64	1	96.60	15.72	1	97.33	14.80	1	97.86	13.87
1.1	95.05	18.31	1.1	96.26	17.29	1.1	97.07	16.27	1.1	97.64	15.26
1.2	94.60	19.97	1.2	95.92	18.86	1.2	96.80	17.75	1.2	97.43	16.64
1.3	94.15	21.64	1.3	95.58	20.44	1.3	96.53	19.23	1.3	97.21	18.03
1.4	93.70	23.30	1.4	95.24	22.01	1.4	96.27	20.71	1.4	97.00	19.42
1.5	93.25	24.97	1.5	94.90	23.58	1.5	96.00	22.19	1.5	96.79	20.81
1.6	92.80	26.63	1.6	94.56	25.15	1.6	95.73	23.67	1.6	96.57	22.19
1.7	92.35	28.30	1.7	94.22	26.72	1.7	95.47	25.15	1.7	96.36	23.58
1.8	91.90	29.96	1.8	93.88	28.30	1.8	95.20	26.63	1.8	96.14	24.97
1.9	91.45	31.62	1.9	93.54	29.87	1.9	94.93	28.11	1.9	95.93	26.35
2	91.00	33.29	2	93.20	31.44	2	94.67	29.59	2	95.71	27.74
2.5	88.75	41.61	2.5	91.50	39.30	2.5	93.33	36.99	2.5	94.64	34.68
3	86.50	49.93	3	89.80	47.16	3	92.00	44.39	3	93.57	41.61
3.5	84.25	58.26	3.5	88.10	55.02	3.5	90.67	51.78	3.5	92.50	48.55
4	82.00	66.58	4	86.40	62.88	4	89.33	59.18	4	91.43	55.48
4.5	79.75	74.90	4.5	84.70	70.74	4.5	88.00	66.58	4.5	90.36	62.42
5	77.50	83.22	5	83.00	78.60	5	86.67	73.98	5	89.29	69.35

% volume to % weight

HC =	65	lb/lb-mole
	65	% vol
	80.63	% wt

Air =	29	lb/lb-mole
	35.00	% vol
	19.37	% wt

% weight to % volume

HC =	65	lb/lb-mole
	80.63	% wt
	65.00	% vol

Air =	29	lb/lb-mole
	19.37	% wt
	35.00	% vol

40	efficiency	mg/liter
0.1	99.83	1.29
0.2	99.65	2.59
0.3	99.48	3.88
0.4	99.30	5.18
0.5	99.13	6.47
0.6	98.95	7.77
0.7	98.78	9.06
0.8	98.60	10.36
0.9	98.43	11.65
1	98.25	12.95
1.1	98.08	14.24
1.2	97.90	15.54
1.3	97.73	16.83
1.4	97.55	18.12
1.5	97.38	19.42
1.6	97.20	20.71
1.7	97.03	22.01
1.8	96.85	23.30
1.9	96.68	24.60
2	96.50	25.89
2.5	95.63	32.36
3	94.75	38.84
3.5	93.88	45.31
4	93.00	51.78
4.5	92.13	58.26
5	91.25	64.73

45	efficiency	mg/liter
0.1	99.86	1.20
0.2	99.71	2.40
0.3	99.57	3.61
0.4	99.42	4.81
0.5	99.28	6.01
0.6	99.13	7.21
0.7	98.99	8.41
0.8	98.84	9.62
0.9	98.70	10.82
1	98.56	12.02
1.1	98.41	13.22
1.2	98.27	14.43
1.3	98.12	15.63
1.4	97.98	16.83
1.5	97.83	18.03
1.6	97.69	19.23
1.7	97.54	20.44
1.8	97.40	21.64
1.9	97.26	22.84
2	97.11	24.04
2.5	96.39	30.05
3	95.67	36.06
3.5	94.94	42.07
4	94.22	48.08
4.5	93.50	54.10
5	92.78	60.11

50	efficiency	mg/liter
0.1	99.88	1.11
0.2	99.76	2.22
0.3	99.64	3.33
0.4	99.52	4.44
0.5	99.40	5.55
0.6	99.28	6.66
0.7	99.16	7.77
0.8	99.04	8.88
0.9	98.92	9.99
1	98.80	11.10
1.1	98.68	12.21
1.2	98.56	13.32
1.3	98.44	14.43
1.4	98.32	15.54
1.5	98.20	16.64
1.6	98.08	17.75
1.7	97.96	18.86
1.8	97.84	19.97
1.9	97.72	21.08
2	97.60	22.19
2.5	97.00	27.74
3	96.40	33.29
3.5	95.80	38.84
4	95.20	44.39
4.5	94.60	49.93
5	94.00	55.48

55	efficiency	mg/liter
0.1	99.90	1.02
0.2	99.80	2.03
0.3	99.70	3.05
0.4	99.60	4.07
0.5	99.50	5.09
0.6	99.40	6.10
0.7	99.30	7.12
0.8	99.20	8.14
0.9	99.10	9.15
1	99.00	10.17
1.1	98.90	11.19
1.2	98.80	12.21
1.3	98.70	13.22
1.4	98.60	14.24
1.5	98.50	15.26
1.6	98.40	16.27
1.7	98.30	17.29
1.8	98.20	18.31
1.9	98.10	19.33
2	98.00	20.34
2.5	97.50	25.43
3	97.00	30.52
3.5	96.50	35.60
4	96.00	40.69
4.5	95.50	45.77
5	95.00	50.86

60	efficiency	mg/liter
0.1	99.92	0.92
0.2	99.83	1.85
0.3	99.75	2.77
0.4	99.67	3.70
0.5	99.58	4.62
0.6	99.50	5.55
0.7	99.42	6.47
0.8	99.33	7.40
0.9	99.25	8.32
1	99.17	9.25
1.1	99.08	10.17
1.2	99.00	11.10
1.3	98.92	12.02
1.4	98.83	12.95
1.5	98.75	13.87
1.6	98.67	14.80
1.7	98.58	15.72
1.8	98.50	16.64
1.9	98.42	17.57
2	98.33	18.49
2.5	97.92	23.12
3	97.50	27.74
3.5	97.08	32.36
4	96.67	36.99
4.5	96.25	41.61
5	95.83	46.24

BEST AVAILABLE COPY

DAQSTANDARD R2.08
 Data Viewer R2.08
 Jordan Service Comapny Glen Toloczko 110-27371-5487

Device Type DX100
 Serial No. 12A728148
 File Message RATA TEST
 Time Correction None
 Starting Condition Manual
 Dividing Condition Manual
 Meas Ch. 2
 Math Ch. 0
 Data Count 17947
 Sampling Interval 5.000 sec
 Start Time 2003/03/12 11:11:35 0.000
 Stop Time 2003/03/13 12:07:05 0.000
 Trigger Time 2003/03/13 12:07:05 0.000
 Trigger No. 17948
 Damage Check Not Damaged

Converted Group 1 - 1

Ch. CH01
 Tag
 sec

Date	Time	%C3H8	Average mg/L
2003/03/12	11:11:35	0.000	0.11
2003/03/12	11:11:40	0.000	0.10
2003/03/12	11:11:45	0.000	0.07
2003/03/12	11:11:50	0.000	0.12
2003/03/12	11:11:55	0.000	0.09
2003/03/12	11:12:00	0.000	0.07
2003/03/12	11:12:05	0.000	0.10
2003/03/12	11:12:10	0.000	0.07
2003/03/12	11:12:15	0.000	0.09
2003/03/12	11:12:20	0.000	0.08
2003/03/12	11:12:25	0.000	0.10
2003/03/12	11:12:30	0.000	0.11
2003/03/12	11:12:35	0.000	0.08
2003/03/12	11:12:40	0.000	0.10
2003/03/12	11:12:45	0.000	0.11
2003/03/12	11:12:50	0.000	0.10
2003/03/12	11:12:55	0.000	0.09
2003/03/12	11:13:00	0.000	0.13
2003/03/12	11:13:05	0.000	0.11
2003/03/12	11:13:10	0.000	0.08
2003/03/12	11:13:15	0.000	0.12
2003/03/12	11:13:20	0.000	0.08

cam003.wk4

VRU Emissions and Efficiency from CEM Data
 Estimated Calculations

Use One Truck Load as the Basis for all Calculations

Truck Volume = 81000 gals
 HC vol% in = 30 vol% 3590886
 HC vol% out = 0.02 vol% 3704309
 Purge Air Volume/Fraction = 0.01 NOTE this is variable
 Propane Calibration Gas Density = 7 gm/gal 61946561
 Butane Calibration Gas Density = 9.2 gm/gal 8156221

HC Mass In = 9000 gal x 30% HC x 7 gm/gal
 = 189000 gm

HC Mass Out = ((9000 gal x (1-30% HC)) + (9000 x 0.1)) x 0.02% HC x 7 gm/gal
 = 103 gm

mg/liter unit conversion = HC mass out x 1000 mg/gm x 1/9000 gal x 1/3.785 liter/gal
 = 0.30 mg/liter

Efficiency calculation = (HC mass in - HC Mass out)/HC Mass in x 100%
 = 99.95%

Input: gals, alternate

% volume to % weight
 HC = 86 lb/lb-mole
 = 65 % vol
 = 80.63 % wt

Air = 29 lb/lb-mole
 = 85.00 % vol
 = 99.37 % wt

% weight to % volume
 HC = 65 lb/lb-mole
 = 80.63 % wt
 = 85.00 % vol

Air = 29 lb/lb-mole
 = 85.00 % wt
 = 99.37 % vol

80.00 Average Inlet Concentration
 0.5 mg/L

First Column Date of Test
 Second Column Time of VOC Reading
 Third Column N/A
 Forth Column instantaneous VOC Reading
 Fifth Column 5 min Average VOC Reading
 Last Column mg/L equivalent Reading every 5-minute

BEST AVAILABLE COPY

DAQSTANDARD R2.08
Data Viewer R2.08
Jordan Service Company Gian Tolozzo 110-27371-6487

Device Type DX100
Serial No. 12A728148
File Message RATA TEST
Time Correction None
Starting Condition Manual
Dividing Condition Manual

Mass Ch. 2
Math Ch. 0
Data Count 17947
Sampling Interval 5.000 sec
Start Time 2003/03/12 11:11:35 0.000
Stop Time 2003/03/13 12:07:06 0.000
Trigger Time 2003/03/13 12:07:06 0.000
Trigger No. 17948
Damage Check Not Damaged

Converted Group 1 - 1

VRU Emissions and Efficiency from CEM Data
 Estimated Concentrations: CO (ppm) 1.0, CH4 (ppm) 0.0, HC (ppm) 0.0, SO2 (ppm) 0.0, NOx (ppm) 0.0, O3 (ppm) 0.0, PM10 (ppm) 0.0, PM2.5 (ppm) 0.0, TSP (ppm) 0.0, H2S (ppm) 0.0, NH3 (ppm) 0.0, HCN (ppm) 0.0, HF (ppm) 0.0, HCl (ppm) 0.0, HBr (ppm) 0.0, HI (ppm) 0.0, HNO3 (ppm) 0.0, H2SO4 (ppm) 0.0, H2O (ppm) 0.0, Other (ppm) 0.0, Total (ppm) 0.0

Use One-Tank Level as the Basis for all Calculations
 Tank Volume: 1000.000 gal
 HC Vol% Inlet: 1.000000 Vol% 3.000000
 HC Vol% Out: 1.000000 Vol% 3.000000
 Purge Air Volume Fraction: 0.100000 NOTE: this is variable
 Propane Calibration Gas Density: 0.500000 gm/gal 0.500000
 Butane Calibration Gas Density: 0.500000 gm/gal 0.500000

HC Mass In: 4000.000 gm HC / 1000.000 gal = 4.000000 gm/gal
 HC Mass Out: (1000.000 gal x 1.000000 HC) - (1000.000 gal x 0.100000 HC) = 900.000 gm
 HC Mass Out: 900.000 gm
 HC Mass Out: (900.000 gm / 1000.000 gal) = 0.900000 gm/gal
 HC Mass Out: 0.900000 gm/gal

HC Mass Out Conversion: HC mass out x 1000 mg/gal x 1.000000 gal / 13.368 liter/gal = 67.368 mg/liter
 HC Mass Out: 67.368 mg/liter

Efficiency calculation: (HC Mass In - HC Mass Out) / HC Mass In x 100%
 Efficiency: (4.000000 - 0.900000) / 4.000000 x 100% = 77.500000%

Date	Time	Ch. Tag	CH01	Average mg/L	%C3H8
2003/03/12	11:11:35		0.000	0.11	
2003/03/12	11:11:40		0.000	0.10	
2003/03/12	11:11:45		0.000	0.07	
2003/03/12	11:11:50		0.000	0.12	
2003/03/12	11:11:55		0.000	0.06	
2003/03/12	11:12:00		0.000	0.07	
2003/03/12	11:12:05		0.000	0.10	
2003/03/12	11:12:10		0.000	0.07	
2003/03/12	11:12:15		0.000	0.09	
2003/03/12	11:12:20		0.000	0.08	
2003/03/12	11:12:25		0.000	0.10	
2003/03/12	11:12:30		0.000	0.11	
2003/03/12	11:12:35		0.000	0.08	
2003/03/12	11:12:40		0.000	0.10	
2003/03/12	11:12:45		0.000	0.11	
2003/03/12	11:12:50		0.000	0.10	
2003/03/12	11:12:55		0.000	0.09	
2003/03/12	11:13:00		0.000	0.13	
2003/03/12	11:13:05		0.000	0.11	
2003/03/12	11:13:10		0.000	0.08	
2003/03/12	11:13:15		0.000	0.12	
2003/03/12	11:13:20		0.000	0.08	
2003/03/12	11:13:25		0.000	0.11	
2003/03/12	11:13:30		0.000	0.11	
2003/03/12	11:13:35		0.000	0.11	
2003/03/12	11:13:40		0.000	0.12	
2003/03/12	11:13:45		0.000	0.10	
2003/03/12	11:13:50		0.000	0.13	
2003/03/12	11:13:55		0.000	0.12	
2003/03/12	11:14:00		0.000	0.12	
2003/03/12	11:14:05		0.000	0.13	
2003/03/12	11:14:10		0.000	0.15	
2003/03/12	11:14:15		0.000	0.14	
2003/03/12	11:14:20		0.000	0.11	
2003/03/12	11:14:25		0.000	0.16	
2003/03/12	11:14:30		0.000	0.12	
2003/03/12	11:14:35		0.000	0.12	
2003/03/12	11:14:40		0.000	0.14	
2003/03/12	11:14:45		0.000	0.12	
2003/03/12	11:14:50		0.000	0.13	
2003/03/12	11:14:55		0.000	0.11	
2003/03/12	11:15:00		0.000	0.14	
2003/03/12	11:15:05		0.000	0.13	
2003/03/12	11:15:10		0.000	0.12	
2003/03/12	11:15:15		0.000	0.15	
2003/03/12	11:15:20		0.000	0.16	
2003/03/12	11:15:25		0.000	0.14	
2003/03/12	11:15:30		0.000	0.12	
2003/03/12	11:15:35		0.000	0.16	
2003/03/12	11:15:40		0.000	0.14	
2003/03/12	11:15:45		0.000	0.12	
2003/03/12	11:15:50		0.000	0.15	
2003/03/12	11:15:55		0.000	0.11	
2003/03/12	11:16:00		0.000	0.13	
2003/03/12	11:16:05		0.000	0.12	
2003/03/12	11:16:10		0.000	0.13	
2003/03/12	11:16:15		0.000	0.14	
2003/03/12	11:16:20		0.000	0.11	
2003/03/12	11:16:25		0.000	0.14	
2003/03/12	11:16:30		0.000	0.14	
2003/03/12	11:16:35		0.000	0.14	
2003/03/12	11:16:40		0.000	0.13	
2003/03/12	11:16:45		0.000	0.16	
2003/03/12	11:16:50		0.000	0.14	
2003/03/12	11:16:55		0.000	0.11	
2003/03/12	11:17:00		0.000	0.16	
2003/03/12	11:17:05		0.000	0.11	
2003/03/12	11:17:10		0.000	0.13	
2003/03/12	11:17:15		0.000	0.18	
2003/03/12	11:17:20		0.000	0.12	
2003/03/12	11:17:25		0.000	0.15	
2003/03/12	11:17:30		0.000	0.11	
2003/03/12	11:17:35		0.000	0.14	
2003/03/12	11:17:40		0.000	0.14	
2003/03/12	11:17:45		0.000	0.13	
2003/03/12	11:17:50		0.000	0.16	
2003/03/12	11:17:55		0.000	0.16	
2003/03/12	11:18:00		0.000	0.14	
2003/03/12	11:18:05		0.000	0.11	
2003/03/12	11:18:10		0.000	0.16	
2003/03/12	11:18:15		0.000	0.12	
2003/03/12	11:18:20		0.000	0.12	
2003/03/12	11:18:25		0.000	0.14	
2003/03/12	11:18:30		0.000	0.11	
2003/03/12	11:18:35		0.000	0.13	
2003/03/12	11:18:40		0.000	0.11	
2003/03/12	11:18:45		0.000	0.13	
2003/03/12	11:18:50		0.000	0.13	
2003/03/12	11:18:55		0.000	0.11	
2003/03/12	11:19:00		0.000	0.14	
2003/03/12	11:19:05		0.000	0.16	
2003/03/12	11:19:10		0.000	0.13	
2003/03/12	11:19:15		0.000	0.11	
2003/03/12	11:19:20		0.000	0.16	
2003/03/12	11:19:25		0.000	0.18	
2003/03/12	11:19:30		0.000	0.11	
2003/03/12	11:19:35		0.000	0.15	
2003/03/12	11:19:40		0.000	0.11	
2003/03/12	11:19:45		0.000	0.13	
2003/03/12	11:19:50		0.000	0.12	
2003/03/12	11:19:55		0.000	0.13	
2003/03/12	11:20:00		0.000	0.14	
2003/03/12	11:20:05		0.000	0.11	
2003/03/12	11:20:10		0.000	0.14	
2003/03/12	11:20:15		0.000	0.14	
2003/03/12	11:20:20		0.000	0.13	

Average mg/L: 0.6
 Average Inlet Concentration: 60.000 mg/liter

Average mg/L: 0.13
 Average Inlet Concentration: 13.000 mg/liter

Average mg/L: 0.10
 Average Inlet Concentration: 10.000 mg/liter

2003/03/12	11:20:26	0.000	0.13
2003/03/12	11:20:30	0.000	0.10
2003/03/12	11:20:35	0.000	0.14
2003/03/12	11:20:40	0.000	0.11
2003/03/12	11:20:45	0.000	0.10
2003/03/12	11:20:50	0.000	0.11
2003/03/12	11:20:55	0.000	0.12
2003/03/12	11:21:00	0.000	0.14
2003/03/12	11:21:05	0.000	0.12
2003/03/12	11:21:10	0.000	0.13
2003/03/12	11:21:15	0.000	0.11
2003/03/12	11:21:20	0.000	0.14
2003/03/12	11:21:25	0.000	0.13
2003/03/12	11:21:30	0.000	0.12
2003/03/12	11:21:35	0.000	0.13
2003/03/12	11:21:40	0.000	0.16
2003/03/12	11:21:45	0.000	0.14
2003/03/12	11:21:50	0.000	0.11
2003/03/12	11:21:55	0.000	0.16
2003/03/12	11:22:00	0.000	0.13
2003/03/12	11:22:05	0.000	0.11
2003/03/12	11:22:10	0.000	0.14
2003/03/12	11:22:15	0.000	0.10
2003/03/12	11:22:20	0.000	0.12
2003/03/12	11:22:25	0.000	0.11
2003/03/12	11:22:30	0.000	0.12
2003/03/12	11:22:35	0.000	0.13
2003/03/12	11:22:40	0.000	0.11
2003/03/12	11:22:45	0.000	0.14
2003/03/12	11:22:50	0.000	0.14
2003/03/12	11:22:55	0.000	0.13
2003/03/12	11:23:00	0.000	0.12
2003/03/12	11:23:05	0.000	0.16
2003/03/12	11:23:10	0.000	0.14
2003/03/12	11:23:15	0.000	0.11
2003/03/12	11:23:20	0.000	0.16
2003/03/12	11:23:25	0.000	0.09
2003/03/12	11:23:30	0.000	0.08
2003/03/12	11:23:35	0.000	0.06
2003/03/12	11:23:40	0.000	0.02
2003/03/12	11:23:45	0.000	0.02
2003/03/12	11:23:50	0.000	-0.01
2003/03/12	11:23:55	0.000	0.01
2003/03/12	11:24:00	0.000	0.00
2003/03/12	11:24:05	0.000	0.01
2003/03/12	11:24:10	0.000	0.04
2003/03/12	11:24:15	0.000	0.07
2003/03/12	11:24:20	0.000	0.05
2003/03/12	11:24:25	0.000	0.02
2003/03/12	11:24:30	0.000	0.06
2003/03/12	11:24:35	0.000	0.01
2003/03/12	11:24:40	0.000	0.00
2003/03/12	11:24:45	0.000	0.02
2003/03/12	11:24:50	0.000	-0.01
2003/03/12	11:24:55	0.000	0.01
2003/03/12	11:25:00	0.000	-0.01
2003/03/12	11:25:05	0.000	0.01
2003/03/12	11:25:10	0.000	0.01
2003/03/12	11:25:15	0.000	-0.01
2003/03/12	11:25:20	0.000	0.02
2003/03/12	11:25:25	0.000	0.02
2003/03/12	11:25:30	0.000	0.01
2003/03/12	11:25:35	0.000	-0.01
2003/03/12	11:25:40	0.000	0.03
2003/03/12	11:25:45	0.000	0.01
2003/03/12	11:25:50	0.000	-0.01
2003/03/12	11:25:55	0.000	0.03
2003/03/12	11:26:00	0.000	-0.02
2003/03/12	11:26:05	0.000	0.01
2003/03/12	11:26:10	0.000	0.00
2003/03/12	11:26:15	0.000	0.00
2003/03/12	11:26:20	0.000	0.02
2003/03/12	11:26:25	0.000	-0.01
2003/03/12	11:26:30	0.000	0.03
2003/03/12	11:26:35	0.000	0.03
2003/03/12	11:26:40	0.000	0.04
2003/03/12	11:26:45	0.000	0.04
2003/03/12	11:26:50	0.000	0.07
2003/03/12	11:26:55	0.000	0.08
2003/03/12	11:27:00	0.000	0.04
2003/03/12	11:27:05	0.000	0.09
2003/03/12	11:27:10	0.000	0.08
2003/03/12	11:27:15	0.000	0.07
2003/03/12	11:27:20	0.000	0.09
2003/03/12	11:27:25	0.000	0.07
2003/03/12	11:27:30	0.000	0.10
2003/03/12	11:27:35	0.000	0.07
2003/03/12	11:27:40	0.000	0.10
2003/03/12	11:27:45	0.000	0.10
2003/03/12	11:27:50	0.000	0.09
2003/03/12	11:27:55	0.000	0.11
2003/03/12	11:28:00	0.000	0.13
2003/03/12	11:28:05	0.000	0.12
2003/03/12	11:28:10	0.000	0.09
2003/03/12	11:28:15	0.000	0.14
2003/03/12	11:28:20	0.000	0.11
2003/03/12	11:28:25	0.000	0.10
2003/03/12	11:28:30	0.000	0.13
2003/03/12	11:28:35	0.000	0.10
2003/03/12	11:28:40	0.000	0.12
2003/03/12	11:28:45	0.000	0.11
2003/03/12	11:28:50	0.000	0.12
2003/03/12	11:28:55	0.000	0.13
2003/03/12	11:29:00	0.000	0.10
2003/03/12	11:29:05	0.000	0.13
2003/03/12	11:29:10	0.000	0.14
2003/03/12	11:29:15	0.000	0.15
2003/03/12	11:29:20	0.000	0.15
2003/03/12	11:29:25	0.000	0.12
2003/03/12	11:29:30	0.000	0.16
2003/03/12	11:29:35	0.000	0.14
2003/03/12	11:29:40	0.000	0.10
2003/03/12	11:29:45	0.000	0.16
2003/03/12	11:29:50	0.000	0.10
2003/03/12	11:29:55	0.000	0.13
2003/03/12	11:30:00	0.000	0.13
2003/03/12	11:30:05	0.000	0.14
2003/03/12	11:30:10	0.000	0.12
2003/03/12	11:30:15	0.000	0.15
2003/03/12	11:30:20	0.000	0.15
2003/03/12	11:30:25	0.000	0.14
2003/03/12	11:30:30	0.000	0.16
2003/03/12	11:30:35	0.000	0.17
2003/03/12	11:30:40	0.000	0.16
2003/03/12	11:30:45	0.000	0.13
2003/03/12	11:30:50	0.000	0.18
2003/03/12	11:30:55	0.000	0.16
2003/03/12	11:31:00	0.000	0.14
2003/03/12	11:31:05	0.000	0.17
2003/03/12	11:31:10	0.000	0.16
2003/03/12	11:31:15	0.000	0.16
2003/03/12	11:31:20	0.000	0.15
2003/03/12	11:31:25	0.000	0.18
2003/03/12	11:31:30	0.000	0.18

0.07

2003/03/12 11:25:00

0.21

2003/03/12 11:30:00

2003/03/12	11:31:35	0.000	0.18
2003/03/12	11:31:40	0.000	0.20
2003/03/12	11:31:45	0.000	0.20
2003/03/12	11:31:50	0.000	0.19
2003/03/12	11:31:55	0.000	0.17
2003/03/12	11:32:00	0.000	0.22
2003/03/12	11:32:05	0.000	0.20
2003/03/12	11:32:10	0.000	0.18
2003/03/12	11:32:15	0.000	0.22
2003/03/12	11:32:20	0.000	0.19
2003/03/12	11:32:25	0.000	0.22
2003/03/12	11:32:30	0.000	0.22
2003/03/12	11:32:35	0.000	0.22
2003/03/12	11:32:40	0.000	0.23
2003/03/12	11:32:45	0.000	0.22
2003/03/12	11:32:50	0.000	0.25
2003/03/12	11:32:55	0.000	0.25
2003/03/12	11:33:00	0.000	0.24
2003/03/12	11:33:05	0.000	0.25
2003/03/12	11:33:10	0.000	0.27
2003/03/12	11:33:15	0.000	0.25
2003/03/12	11:33:20	0.000	0.22
2003/03/12	11:33:25	0.000	0.23
2003/03/12	11:33:30	0.000	0.24
2003/03/12	11:33:35	0.000	0.25
2003/03/12	11:33:40	0.000	0.27
2003/03/12	11:33:45	0.000	0.25
2003/03/12	11:33:50	0.000	0.27
2003/03/12	11:33:55	0.000	0.24
2003/03/12	11:34:00	0.000	0.27
2003/03/12	11:34:05	0.000	0.28
2003/03/12	11:34:10	0.000	0.28
2003/03/12	11:34:15	0.000	0.29
2003/03/12	11:34:20	0.000	0.30
2003/03/12	11:34:25	0.000	0.28
2003/03/12	11:34:30	0.000	0.28
2003/03/12	11:34:35	0.000	0.31
2003/03/12	11:34:40	0.000	0.28
2003/03/12	11:34:45	0.000	0.27
2003/03/12	11:34:50	0.000	0.31
2003/03/12	11:34:55	0.000	0.27
2003/03/12	11:35:00	0.000	0.30
2003/03/12	11:35:05	0.000	0.29
2003/03/12	11:35:10	0.000	0.31
2003/03/12	11:35:15	0.000	0.32
2003/03/12	11:35:20	0.000	0.29
2003/03/12	11:35:25	0.000	0.32
2003/03/12	11:35:30	0.000	0.33
2003/03/12	11:35:35	0.000	0.33
2003/03/12	11:35:40	0.000	0.32
2003/03/12	11:35:45	0.000	0.34
2003/03/12	11:35:50	0.000	0.33
2003/03/12	11:35:55	0.000	0.31
2003/03/12	11:36:00	0.000	0.35
2003/03/12	11:36:05	0.000	0.31
2003/03/12	11:36:10	0.000	0.32
2003/03/12	11:36:15	0.000	0.33
2003/03/12	11:36:20	0.000	0.32
2003/03/12	11:36:25	0.000	0.34
2003/03/12	11:36:30	0.000	0.32
2003/03/12	11:36:35	0.000	0.35
2003/03/12	11:36:40	0.000	0.35
2003/03/12	11:36:45	0.000	0.34
2003/03/12	11:36:50	0.000	0.38
2003/03/12	11:36:55	0.000	0.37
2003/03/12	11:37:00	0.000	0.37
2003/03/12	11:37:05	0.000	0.34
2003/03/12	11:37:10	0.000	0.39
2003/03/12	11:37:15	0.000	0.35
2003/03/12	11:37:20	0.000	0.35
2003/03/12	11:37:25	0.000	0.38
2003/03/12	11:37:30	0.000	0.35
2003/03/12	11:37:35	0.000	0.37
2003/03/12	11:37:40	0.000	0.35
2003/03/12	11:37:45	0.000	0.38
2003/03/12	11:37:50	0.000	0.38
2003/03/12	11:37:55	0.000	0.39
2003/03/12	11:38:00	0.000	0.39
2003/03/12	11:38:05	0.000	0.41
2003/03/12	11:38:10	0.000	0.40
2003/03/12	11:38:15	0.000	0.38
2003/03/12	11:38:20	0.000	0.42
2003/03/12	11:38:25	0.000	0.42
2003/03/12	11:38:30	0.000	0.38
2003/03/12	11:38:35	0.000	0.43
2003/03/12	11:38:40	0.000	0.38
2003/03/12	11:38:45	0.000	0.41
2003/03/12	11:38:50	0.000	0.41
2003/03/12	11:38:55	0.000	0.41
2003/03/12	11:39:00	0.000	0.42
2003/03/12	11:39:05	0.000	0.40
2003/03/12	11:39:10	0.000	0.44
2003/03/12	11:39:15	0.000	0.43
2003/03/12	11:39:20	0.000	0.43
2003/03/12	11:39:25	0.000	0.43
2003/03/12	11:39:30	0.000	0.46
2003/03/12	11:39:35	0.000	0.45
2003/03/12	11:39:40	0.000	0.42
2003/03/12	11:39:45	0.000	0.47
2003/03/12	11:39:50	0.000	0.44
2003/03/12	11:39:55	0.000	0.44
2003/03/12	11:40:00	0.000	0.46
2003/03/12	11:40:05	0.000	0.44
2003/03/12	11:40:10	0.000	0.45
2003/03/12	11:40:15	0.000	0.43
2003/03/12	11:40:20	0.000	0.46
2003/03/12	11:40:25	0.000	0.45
2003/03/12	11:40:30	0.000	0.44
2003/03/12	11:40:35	0.000	0.47
2003/03/12	11:40:40	0.000	0.46
2003/03/12	11:40:45	0.000	0.37
2003/03/12	11:40:50	0.000	0.27
2003/03/12	11:40:55	0.000	0.25
2003/03/12	11:41:00	0.000	0.16
2003/03/12	11:41:05	0.000	0.10
2003/03/12	11:41:10	0.000	0.10
2003/03/12	11:41:15	0.000	0.04
2003/03/12	11:41:20	0.000	0.05
2003/03/12	11:41:25	0.000	0.02
2003/03/12	11:41:30	0.000	0.02
2003/03/12	11:41:35	0.000	0.02
2003/03/12	11:41:40	0.000	0.02
2003/03/12	11:41:45	0.000	0.12
2003/03/12	11:41:50	0.000	0.19
2003/03/12	11:41:55	0.000	0.27
2003/03/12	11:42:00	0.000	0.32
2003/03/12	11:42:05	0.000	0.38
2003/03/12	11:42:10	0.000	0.40
2003/03/12	11:42:15	0.000	0.39
2003/03/12	11:42:20	0.000	0.45
2003/03/12	11:42:25	0.000	0.39
2003/03/12	11:42:30	0.000	0.34
2003/03/12	11:42:35	0.000	0.27
2003/03/12	11:42:40	0.000	0.19

0.37

[REDACTED]

0.16

[REDACTED]

2003/03/12	11:42:45	0.000	0.18
2003/03/12	11:42:50	0.000	0.09
2003/03/12	11:42:55	0.000	0.08
2003/03/12	11:43:00	0.000	0.08
2003/03/12	11:43:05	0.000	0.03
2003/03/12	11:43:10	0.000	0.04
2003/03/12	11:43:15	0.000	0.04
2003/03/12	11:43:20	0.000	0.02
2003/03/12	11:43:25	0.000	-0.01
2003/03/12	11:43:30	0.000	0.04
2003/03/12	11:43:35	0.000	0.00
2003/03/12	11:43:40	0.000	-0.01
2003/03/12	11:43:45	0.000	0.02
2003/03/12	11:43:50	0.000	-0.01
2003/03/12	11:43:55	0.000	0.01
2003/03/12	11:44:00	0.000	-0.01
2003/03/12	11:44:05	0.000	0.01
2003/03/12	11:44:10	0.000	0.02
2003/03/12	11:44:15	0.000	-0.01
2003/03/12	11:44:20	0.000	0.01
2003/03/12	11:44:25	0.000	0.01
2003/03/12	11:44:30	0.000	0.01
2003/03/12	11:44:35	0.000	0.00
2003/03/12	11:44:40	0.000	0.03
2003/03/12	11:44:45	0.000	0.01
2003/03/12	11:44:50	0.000	-0.01
2003/03/12	11:44:55	0.000	0.03
2003/03/12	11:45:00	0.000	-0.01
2003/03/12	11:45:05	0.000	0.01
2003/03/12	11:45:10	0.000	0.02
2003/03/12	11:45:15	0.000	0.02
2003/03/12	11:45:20	0.000	0.04
2003/03/12	11:45:25	0.000	0.02
2003/03/12	11:45:30	0.000	0.06
2003/03/12	11:45:35	0.000	0.06
2003/03/12	11:45:40	0.000	0.06
2003/03/12	11:45:45	0.000	0.07
2003/03/12	11:45:50	0.000	0.09
2003/03/12	11:45:55	0.000	0.09
2003/03/12	11:46:00	0.000	0.06
2003/03/12	11:46:05	0.000	0.11
2003/03/12	11:46:10	0.000	0.08
2003/03/12	11:46:15	0.000	0.08
2003/03/12	11:46:20	0.000	0.10
2003/03/12	11:46:25	0.000	0.08
2003/03/12	11:46:30	0.000	0.08
2003/03/12	11:46:35	0.000	0.07
2003/03/12	11:46:40	0.000	0.09
2003/03/12	11:46:45	0.000	0.10
2003/03/12	11:46:50	0.000	0.08
2003/03/12	11:46:55	0.000	0.09
2003/03/12	11:47:00	0.000	0.11
2003/03/12	11:47:05	0.000	0.09
2003/03/12	11:47:10	0.000	0.07
2003/03/12	11:47:15	0.000	0.12
2003/03/12	11:47:20	0.000	0.10
2003/03/12	11:47:25	0.000	0.07
2003/03/12	11:47:30	0.000	0.11
2003/03/12	11:47:35	0.000	0.08
2003/03/12	11:47:40	0.000	0.09
2003/03/12	11:47:45	0.000	0.08
2003/03/12	11:47:50	0.000	0.09
2003/03/12	11:47:55	0.000	0.10
2003/03/12	11:48:00	0.000	0.07
2003/03/12	11:48:05	0.000	0.10
2003/03/12	11:48:10	0.000	0.09
2003/03/12	11:48:15	0.000	0.09
2003/03/12	11:48:20	0.000	0.09
2003/03/12	11:48:25	0.000	0.11
2003/03/12	11:48:30	0.000	0.10
2003/03/12	11:48:35	0.000	0.07
2003/03/12	11:48:40	0.000	-0.12
2003/03/12	11:48:45	0.000	0.07
2003/03/12	11:48:50	0.000	0.09
2003/03/12	11:48:55	0.000	0.10
2003/03/12	11:49:00	0.000	0.08
2003/03/12	11:49:05	0.000	0.09
2003/03/12	11:49:10	0.000	0.07
2003/03/12	11:49:15	0.000	0.10
2003/03/12	11:49:20	0.000	0.10
2003/03/12	11:49:25	0.000	0.09
2003/03/12	11:49:30	0.000	0.11
2003/03/12	11:49:35	0.000	0.12
2003/03/12	11:49:40	0.000	0.10
2003/03/12	11:49:45	0.000	0.07
2003/03/12	11:49:50	0.000	0.12
2003/03/12	11:49:55	0.000	0.10
2003/03/12	11:50:00	0.000	0.08
2003/03/12	11:50:05	0.000	0.12
2003/03/12	11:50:10	0.000	0.08
2003/03/12	11:50:15	0.000	0.10
2003/03/12	11:50:20	0.000	0.09
2003/03/12	11:50:25	0.000	0.09
2003/03/12	11:50:30	0.000	0.10
2003/03/12	11:50:35	0.000	0.08
2003/03/12	11:50:40	0.000	0.11
2003/03/12	11:50:45	0.000	0.11
2003/03/12	11:50:50	0.000	0.10
2003/03/12	11:50:55	0.000	0.10
2003/03/12	11:51:00	0.000	0.13
2003/03/12	11:51:05	0.000	0.11
2003/03/12	11:51:10	0.000	0.08
2003/03/12	11:51:15	0.000	0.13
2003/03/12	11:51:20	0.000	0.08
2003/03/12	11:51:25	0.000	0.10
2003/03/12	11:51:30	0.000	0.11
2003/03/12	11:51:35	0.000	0.10
2003/03/12	11:51:40	0.000	0.12
2003/03/12	11:51:45	0.000	0.09
2003/03/12	11:51:50	0.000	0.11
2003/03/12	11:51:55	0.000	0.11
2003/03/12	11:52:00	0.000	0.10
2003/03/12	11:52:05	0.000	0.12
2003/03/12	11:52:10	0.000	0.13
2003/03/12	11:52:15	0.000	0.11
2003/03/12	11:52:20	0.000	0.09
2003/03/12	11:52:25	0.000	0.14
2003/03/12	11:52:30	0.000	0.11
2003/03/12	11:52:35	0.000	0.10
2003/03/12	11:52:40	0.000	0.14
2003/03/12	11:52:45	0.000	0.10
2003/03/12	11:52:50	0.000	0.12
2003/03/12	11:52:55	0.000	0.10
2003/03/12	11:53:00	0.000	0.12
2003/03/12	11:53:05	0.000	0.13
2003/03/12	11:53:10	0.000	0.10
2003/03/12	11:53:15	0.000	0.13
2003/03/12	11:53:20	0.000	0.14
2003/03/12	11:53:25	0.000	0.13
2003/03/12	11:53:30	0.000	0.12
2003/03/12	11:53:35	0.000	0.16
2003/03/12	11:53:40	0.000	0.13
2003/03/12	11:53:45	0.000	0.11
2003/03/12	11:53:50	0.000	0.15

0.06

XXXXXXXXXXXXXXXXXXXX

0.12

XXXXXXXXXXXXXXXXXXXX

2003/03/12	12:06:05	0.000	0.18
2003/03/12	12:06:10	0.000	0.17
2003/03/12	12:06:15	0.000	0.18
2003/03/12	12:06:20	0.000	0.13
2003/03/12	12:06:25	0.000	0.14
2003/03/12	12:06:30	0.000	0.15
2003/03/12	12:06:35	0.000	0.16
2003/03/12	12:06:40	0.000	0.15
2003/03/12	12:06:45	0.000	0.17
2003/03/12	12:06:50	0.000	0.15
2003/03/12	12:06:55	0.000	0.18
2003/03/12	12:07:00	0.000	0.17
2003/03/12	12:07:05	0.000	0.17
2003/03/12	12:07:10	0.000	0.18
2003/03/12	12:07:15	0.000	0.20
2003/03/12	12:07:20	0.000	0.19
2003/03/12	12:07:25	0.000	0.18
2003/03/12	12:07:30	0.000	0.25
2003/03/12	12:07:35	0.000	0.24
2003/03/12	12:07:40	0.000	0.27
2003/03/12	12:07:45	0.000	0.26
2003/03/12	12:07:50	0.000	0.23
2003/03/12	12:07:55	0.000	0.27
2003/03/12	12:08:00	0.000	0.23
2003/03/12	12:08:05	0.000	0.26
2003/03/12	12:08:10	0.000	0.28
2003/03/12	12:08:15	0.000	0.26
2003/03/12	12:08:20	0.000	0.26
2003/03/12	12:08:25	0.000	0.24
2003/03/12	12:08:30	0.000	0.27
2003/03/12	12:08:35	0.000	0.27
2003/03/12	12:08:40	0.000	0.27
2003/03/12	12:08:45	0.000	0.29
2003/03/12	12:08:50	0.000	0.30
2003/03/12	12:08:55	0.000	0.29
2003/03/12	12:09:00	0.000	0.27
2003/03/12	12:09:05	0.000	0.33
2003/03/12	12:09:10	0.000	0.29
2003/03/12	12:09:15	0.000	0.30
2003/03/12	12:09:20	0.000	0.33
2003/03/12	12:09:25	0.000	0.30
2003/03/12	12:09:30	0.000	0.33
2003/03/12	12:09:35	0.000	0.31
2003/03/12	12:09:40	0.000	0.33
2003/03/12	12:09:45	0.000	0.33
2003/03/12	12:09:50	0.000	0.31
2003/03/12	12:09:55	0.000	0.35
2003/03/12	12:10:00	0.000	0.38
2003/03/12	12:10:05	0.000	0.35
2003/03/12	12:10:10	0.000	0.34
2003/03/12	12:10:15	0.000	0.38
2003/03/12	12:10:20	0.000	0.37
2003/03/12	12:10:25	0.000	0.34
2003/03/12	12:10:30	0.000	0.39
2003/03/12	12:10:35	0.000	0.34
2003/03/12	12:10:40	0.000	0.37
2003/03/12	12:10:45	0.000	0.37
2003/03/12	12:10:50	0.000	0.37
2003/03/12	12:10:55	0.000	0.40
2003/03/12	12:11:00	0.000	0.37
2003/03/12	12:11:05	0.000	0.40
2003/03/12	12:11:10	0.000	0.41
2003/03/12	12:11:15	0.000	0.40
2003/03/12	12:11:20	0.000	0.41
2003/03/12	12:11:25	0.000	0.43
2003/03/12	12:11:30	0.000	0.41
2003/03/12	12:11:35	0.000	0.40
2003/03/12	12:11:40	0.000	0.46
2003/03/12	12:11:45	0.000	0.41
2003/03/12	12:11:50	0.000	0.42
2003/03/12	12:11:55	0.000	0.44
2003/03/12	12:12:00	0.000	0.42
2003/03/12	12:12:05	0.000	0.44
2003/03/12	12:12:10	0.000	0.42
2003/03/12	12:12:15	0.000	0.45
2003/03/12	12:12:20	0.000	0.45
2003/03/12	12:12:25	0.000	0.43
2003/03/12	12:12:30	0.000	0.48
2003/03/12	12:12:35	0.000	0.47
2003/03/12	12:12:40	0.000	0.46
2003/03/12	12:12:45	0.000	0.44
2003/03/12	12:12:50	0.000	0.48
2003/03/12	12:12:55	0.000	0.48
2003/03/12	12:13:00	0.000	0.46
2003/03/12	12:13:05	0.000	0.49
2003/03/12	12:13:10	0.000	0.45
2003/03/12	12:13:15	0.000	0.48
2003/03/12	12:13:20	0.000	0.47
2003/03/12	12:13:25	0.000	0.48
2003/03/12	12:13:30	0.000	0.50
2003/03/12	12:13:35	0.000	0.47
2003/03/12	12:13:40	0.000	0.50
2003/03/12	12:13:45	0.000	0.50
2003/03/12	12:13:50	0.000	0.50
2003/03/12	12:13:55	0.000	0.50
2003/03/12	12:14:00	0.000	0.52
2003/03/12	12:14:05	0.000	0.52
2003/03/12	12:14:10	0.000	0.48
2003/03/12	12:14:15	0.000	0.54
2003/03/12	12:14:20	0.000	0.59
2003/03/12	12:14:25	0.000	0.51
2003/03/12	12:14:30	0.000	0.53
2003/03/12	12:14:35	0.000	0.51
2003/03/12	12:14:40	0.000	0.53
2003/03/12	12:14:45	0.000	0.51
2003/03/12	12:14:50	0.000	0.54
2003/03/12	12:14:55	0.000	0.54
2003/03/12	12:15:00	0.000	0.53
2003/03/12	12:15:05	0.000	0.53
2003/03/12	12:15:10	0.000	0.57
2003/03/12	12:15:15	0.000	0.55
2003/03/12	12:15:20	0.000	0.53
2003/03/12	12:15:25	0.000	0.58
2003/03/12	12:15:30	0.000	0.59
2003/03/12	12:15:35	0.000	0.54
2003/03/12	12:15:40	0.000	0.58
2003/03/12	12:15:45	0.000	0.55
2003/03/12	12:15:50	0.000	0.57
2003/03/12	12:15:55	0.000	0.58
2003/03/12	12:16:00	0.000	0.58
2003/03/12	12:16:05	0.000	0.59
2003/03/12	12:16:10	0.000	0.57

0.23

Resized to 11/16/03

0.46

Resized to 11/16/03

2003/03/12	12:16:15	0.000	0.60
2003/03/12	12:16:20	0.000	0.60
2003/03/12	12:16:25	0.000	0.69
2003/03/12	12:16:30	0.000	0.69
2003/03/12	12:16:35	0.000	0.62
2003/03/12	12:16:40	0.000	0.61
2003/03/12	12:16:45	0.000	0.67
2003/03/12	12:16:50	0.000	0.61
2003/03/12	12:16:55	0.000	0.67
2003/03/12	12:17:00	0.000	0.69
2003/03/12	12:17:05	0.000	0.68
2003/03/12	12:17:10	0.000	0.61
2003/03/12	12:17:15	0.000	0.43
2003/03/12	12:17:20	0.000	0.31
2003/03/12	12:17:25	0.000	0.26
2003/03/12	12:17:30	0.000	0.20
2003/03/12	12:17:35	0.000	0.14
2003/03/12	12:17:40	0.000	0.13
2003/03/12	12:17:45	0.000	0.10
2003/03/12	12:17:50	0.000	0.06
2003/03/12	12:17:55	0.000	0.02
2003/03/12	12:18:00	0.000	0.02
2003/03/12	12:18:05	0.000	0.03
2003/03/12	12:18:10	0.000	0.09
2003/03/12	12:18:15	0.000	0.19
2003/03/12	12:18:20	0.000	0.28
2003/03/12	12:18:25	0.000	0.37
2003/03/12	12:18:30	0.000	0.43
2003/03/12	12:18:35	0.000	0.49
2003/03/12	12:18:40	0.000	0.63
2003/03/12	12:18:45	0.000	0.63
2003/03/12	12:18:50	0.000	0.67
2003/03/12	12:18:55	0.000	0.62
2003/03/12	12:19:00	0.000	0.41
2003/03/12	12:19:05	0.000	0.31
2003/03/12	12:19:10	0.000	0.27
2003/03/12	12:19:15	0.000	0.19
2003/03/12	12:19:20	0.000	0.11
2003/03/12	12:19:25	0.000	0.13
2003/03/12	12:19:30	0.000	0.05
2003/03/12	12:19:35	0.000	0.05
2003/03/12	12:19:40	0.000	0.04
2003/03/12	12:19:45	0.000	0.02
2003/03/12	12:19:50	0.000	0.04
2003/03/12	12:19:55	0.000	0.00
2003/03/12	12:20:00	0.000	0.02
2003/03/12	12:20:05	0.000	0.01
2003/03/12	12:20:10	0.000	0.01
2003/03/12	12:20:15	0.000	0.02
2003/03/12	12:20:20	0.000	0.02
2003/03/12	12:20:25	0.000	0.01
2003/03/12	12:20:30	0.000	-0.01
2003/03/12	12:20:35	0.000	0.03
2003/03/12	12:20:40	0.000	0.00
2003/03/12	12:20:45	0.000	-0.01
2003/03/12	12:20:50	0.000	0.02
2003/03/12	12:20:55	0.000	-0.01
2003/03/12	12:21:00	0.000	0.01
2003/03/12	12:21:05	0.000	-0.01
2003/03/12	12:21:10	0.000	0.01
2003/03/12	12:21:15	0.000	0.02
2003/03/12	12:21:20	0.000	0.00
2003/03/12	12:21:25	0.000	0.03
2003/03/12	12:21:30	0.000	0.04
2003/03/12	12:21:35	0.000	0.04
2003/03/12	12:21:40	0.000	0.03
2003/03/12	12:21:45	0.000	0.08
2003/03/12	12:21:50	0.000	0.07
2003/03/12	12:21:55	0.000	0.05
2003/03/12	12:22:00	0.000	0.10
2003/03/12	12:22:05	0.000	0.06
2003/03/12	12:22:10	0.000	0.09
2003/03/12	12:22:15	0.000	0.09
2003/03/12	12:22:20	0.000	0.09
2003/03/12	12:22:25	0.000	0.11
2003/03/12	12:22:30	0.000	0.08
2003/03/12	12:22:35	0.000	0.11
2003/03/12	12:22:40	0.000	0.10
2003/03/12	12:22:45	0.000	0.10
2003/03/12	12:22:50	0.000	0.11
2003/03/12	12:22:55	0.000	0.12
2003/03/12	12:23:00	0.000	0.11
2003/03/12	12:23:05	0.000	0.06
2003/03/12	12:23:10	0.000	0.12
2003/03/12	12:23:15	0.000	0.09
2003/03/12	12:23:20	0.000	0.09
2003/03/12	12:23:25	0.000	0.11
2003/03/12	12:23:30	0.000	0.09
2003/03/12	12:23:35	0.000	0.10
2003/03/12	12:23:40	0.000	0.09
2003/03/12	12:23:45	0.000	0.10
2003/03/12	12:23:50	0.000	0.11
2003/03/12	12:23:55	0.000	0.09
2003/03/12	12:24:00	0.000	0.11
2003/03/12	12:24:05	0.000	0.12
2003/03/12	12:24:10	0.000	0.11
2003/03/12	12:24:15	0.000	0.10
2003/03/12	12:24:20	0.000	0.13
2003/03/12	12:24:25	0.000	0.12
2003/03/12	12:24:30	0.000	0.09
2003/03/12	12:24:35	0.000	0.13
2003/03/12	12:24:40	0.000	0.09
2003/03/12	12:24:45	0.000	0.12
2003/03/12	12:24:50	0.000	0.12
2003/03/12	12:24:55	0.000	0.11
2003/03/12	12:25:00	0.000	0.12
2003/03/12	12:25:05	0.000	0.10
2003/03/12	12:25:10	0.000	0.13
2003/03/12	12:25:15	0.000	0.13
2003/03/12	12:25:20	0.000	0.12
2003/03/12	12:25:25	0.000	0.13
2003/03/12	12:25:30	0.000	0.16
2003/03/12	12:25:35	0.000	0.14
2003/03/12	12:25:40	0.000	0.10
2003/03/12	12:25:45	0.000	0.15
2003/03/12	12:25:50	0.000	0.12
2003/03/12	12:25:55	0.000	0.11
2003/03/12	12:26:00	0.000	0.14
2003/03/12	12:26:05	0.000	0.11
2003/03/12	12:26:10	0.000	0.13
2003/03/12	12:26:15	0.000	0.11
2003/03/12	12:26:20	0.000	0.14
2003/03/12	12:26:25	0.000	0.14
2003/03/12	12:26:30	0.000	0.12
2003/03/12	12:26:35	0.000	0.18
2003/03/12	12:26:40	0.000	0.18
2003/03/12	12:26:45	0.000	0.16
2003/03/12	12:26:50	0.000	0.13
2003/03/12	12:26:55	0.000	0.18
2003/03/12	12:27:00	0.000	0.18
2003/03/12	12:27:05	0.000	0.13
2003/03/12	12:27:10	0.000	0.17
2003/03/12	12:27:15	0.000	0.13
2003/03/12	12:27:20	0.000	0.18

0.38

2003/03/12 12:20:00

0.07

2003/03/12 12:25:05

2003/03/12	12:27:25	0.000	0.15
2003/03/12	12:27:30	0.000	0.15
2003/03/12	12:27:35	0.000	0.15
2003/03/12	12:27:40	0.000	0.14
2003/03/12	12:27:45	0.000	0.17
2003/03/12	12:27:50	0.000	0.16
2003/03/12	12:27:55	0.000	0.16
2003/03/12	12:28:00	0.000	0.17
2003/03/12	12:28:05	0.000	0.18
2003/03/12	12:28:10	0.000	0.17
2003/03/12	12:28:15	0.000	0.14
2003/03/12	12:28:20	0.000	0.19
2003/03/12	12:28:25	0.000	0.15
2003/03/12	12:28:30	0.000	0.15
2003/03/12	12:28:35	0.000	0.18
2003/03/12	12:28:40	0.000	0.15
2003/03/12	12:28:45	0.000	0.18
2003/03/12	12:28:50	0.000	0.15
2003/03/12	12:28:55	0.000	0.17
2003/03/12	12:29:00	0.000	0.18
2003/03/12	12:29:05	0.000	0.16
2003/03/12	12:29:10	0.000	0.19
2003/03/12	12:29:15	0.000	0.19
2003/03/12	12:29:20	0.000	0.18
2003/03/12	12:29:25	0.000	0.18
2003/03/12	12:29:30	0.000	0.20
2003/03/12	12:29:35	0.000	0.18
2003/03/12	12:29:40	0.000	0.15
2003/03/12	12:29:45	0.000	0.19
2003/03/12	12:29:50	0.000	0.15
2003/03/12	12:29:55	0.000	0.17
2003/03/12	12:30:00	0.000	0.16
2003/03/12	12:30:05	0.000	0.17
2003/03/12	12:30:10	0.000	0.19
2003/03/12	12:30:15	0.000	0.16
2003/03/12	12:30:20	0.000	0.18
2003/03/12	12:30:25	0.000	0.18
2003/03/12	12:30:30	0.000	0.19
2003/03/12	12:30:35	0.000	0.19
2003/03/12	12:30:40	0.000	0.20
2003/03/12	12:30:45	0.000	0.19
2003/03/12	12:30:50	0.000	0.17
2003/03/12	12:30:55	0.000	0.22
2003/03/12	12:31:00	0.000	0.18
2003/03/12	12:31:05	0.000	0.19
2003/03/12	12:31:10	0.000	0.21
2003/03/12	12:31:15	0.000	0.19
2003/03/12	12:31:20	0.000	0.22
2003/03/12	12:31:25	0.000	0.19
2003/03/12	12:31:30	0.000	0.22
2003/03/12	12:31:35	0.000	0.23
2003/03/12	12:31:40	0.000	0.22
2003/03/12	12:31:45	0.000	0.24
2003/03/12	12:31:50	0.000	0.26
2003/03/12	12:31:55	0.000	0.25
2003/03/12	12:32:00	0.000	0.22
2003/03/12	12:32:05	0.000	0.27
2003/03/12	12:32:10	0.000	0.25
2003/03/12	12:32:15	0.000	0.23
2003/03/12	12:32:20	0.000	0.27
2003/03/12	12:32:25	0.000	0.23
2003/03/12	12:32:30	0.000	0.25
2003/03/12	12:32:35	0.000	0.24
2003/03/12	12:32:40	0.000	0.25
2003/03/12	12:32:45	0.000	0.27
2003/03/12	12:32:50	0.000	0.23
2003/03/12	12:32:55	0.000	0.26
2003/03/12	12:33:00	0.000	0.25
2003/03/12	12:33:05	0.000	0.25
2003/03/12	12:33:10	0.000	0.25
2003/03/12	12:33:15	0.000	0.27
2003/03/12	12:33:20	0.000	0.27
2003/03/12	12:33:25	0.000	0.23
2003/03/12	12:33:30	0.000	0.28
2003/03/12	12:33:35	0.000	0.24
2003/03/12	12:33:40	0.000	0.25
2003/03/12	12:33:45	0.000	0.27
2003/03/12	12:33:50	0.000	0.24
2003/03/12	12:33:55	0.000	0.26
2003/03/12	12:34:00	0.000	0.24
2003/03/12	12:34:05	0.000	0.27
2003/03/12	12:34:10	0.000	0.27
2003/03/12	12:34:15	0.000	0.25
2003/03/12	12:34:20	0.000	0.27
2003/03/12	12:34:25	0.000	0.26
2003/03/12	12:34:30	0.000	0.27
2003/03/12	12:34:35	0.000	0.24
2003/03/12	12:34:40	0.000	0.29
2003/03/12	12:34:45	0.000	0.27
2003/03/12	12:34:50	0.000	0.25
2003/03/12	12:34:55	0.000	0.29
2003/03/12	12:35:00	0.000	0.24
2003/03/12	12:35:05	0.000	0.26
2003/03/12	12:35:10	0.000	0.26
2003/03/12	12:35:15	0.000	0.26
2003/03/12	12:35:20	0.000	0.27
2003/03/12	12:35:25	0.000	0.25
2003/03/12	12:35:30	0.000	0.26
2003/03/12	12:35:35	0.000	0.27
2003/03/12	12:35:40	0.000	0.27
2003/03/12	12:35:45	0.000	0.26
2003/03/12	12:35:50	0.000	0.29
2003/03/12	12:35:55	0.000	0.28
2003/03/12	12:36:00	0.000	0.24
2003/03/12	12:36:05	0.000	0.26
2003/03/12	12:36:10	0.000	0.26
2003/03/12	12:36:15	0.000	0.25
2003/03/12	12:36:20	0.000	0.24
2003/03/12	12:36:25	0.000	0.20
2003/03/12	12:36:30	0.000	0.13
2003/03/12	12:36:35	0.000	0.11
2003/03/12	12:36:40	0.000	0.05
2003/03/12	12:36:45	0.000	0.05
2003/03/12	12:36:50	0.000	0.04
2003/03/12	12:36:55	0.000	0.04
2003/03/12	12:37:00	0.000	0.05
2003/03/12	12:37:05	0.000	0.07
2003/03/12	12:37:10	0.000	0.08
2003/03/12	12:37:15	0.000	0.12
2003/03/12	12:37:20	0.000	0.08
2003/03/12	12:37:25	0.000	0.04
2003/03/12	12:37:30	0.000	0.06
2003/03/12	12:37:35	0.000	0.01
2003/03/12	12:37:40	0.000	0.02
2003/03/12	12:37:45	0.000	0.00
2003/03/12	12:37:50	0.000	0.01
2003/03/12	12:37:55	0.000	0.01
2003/03/12	12:38:00	0.000	-0.01
2003/03/12	12:38:05	0.000	0.02
2003/03/12	12:38:10	0.000	0.01
2003/03/12	12:38:15	0.000	0.01
2003/03/12	12:38:20	0.000	0.00
2003/03/12	12:38:25	0.000	0.03
2003/03/12	12:38:30	0.000	0.02

0.15

2003/03/12 12:30:05

0.23

2003/03/12 12:35:05

2003/03/12	12:38:35	0.000	0.00
2003/03/12	12:38:40	0.000	0.04
2003/03/12	12:38:45	0.000	0.00
2003/03/12	12:38:50	0.000	0.02
2003/03/12	12:38:55	0.000	0.03
2003/03/12	12:39:00	0.000	0.02
2003/03/12	12:39:05	0.000	0.04
2003/03/12	12:39:10	0.000	0.01
2003/03/12	12:39:15	0.000	0.05
2003/03/12	12:39:20	0.000	0.08
2003/03/12	12:39:25	0.000	0.08
2003/03/12	12:39:30	0.000	0.09
2003/03/12	12:39:35	0.000	0.11
2003/03/12	12:39:40	0.000	0.11
2003/03/12	12:39:45	0.000	0.09
2003/03/12	12:39:50	0.000	0.15
2003/03/12	12:39:55	0.000	0.13
2003/03/12	12:40:00	0.000	0.12
2003/03/12	12:40:05	0.000	0.18
2003/03/12	12:40:10	0.000	0.13
2003/03/12	12:40:15	0.000	0.15
2003/03/12	12:40:20	0.000	0.14
2003/03/12	12:40:25	0.000	0.18
2003/03/12	12:40:30	0.000	0.17
2003/03/12	12:40:35	0.000	0.14
2003/03/12	12:40:40	0.000	0.17
2003/03/12	12:40:45	0.000	0.18
2003/03/12	12:40:50	0.000	0.17
2003/03/12	12:40:55	0.000	0.18
2003/03/12	12:41:00	0.000	0.19
2003/03/12	12:41:05	0.000	0.18
2003/03/12	12:41:10	0.000	0.15
2003/03/12	12:41:15	0.000	0.20
2003/03/12	12:41:20	0.000	0.18
2003/03/12	12:41:25	0.000	0.18
2003/03/12	12:41:30	0.000	0.19
2003/03/12	12:41:35	0.000	0.18
2003/03/12	12:41:40	0.000	0.20
2003/03/12	12:41:45	0.000	0.17
2003/03/12	12:41:50	0.000	0.20
2003/03/12	12:41:55	0.000	0.21
2003/03/12	12:42:00	0.000	0.20
2003/03/12	12:42:05	0.000	0.22
2003/03/12	12:42:10	0.000	0.24
2003/03/12	12:42:15	0.000	0.24
2003/03/12	12:42:20	0.000	0.21
2003/03/12	12:42:25	0.000	0.28
2003/03/12	12:42:30	0.000	0.24
2003/03/12	12:42:35	0.000	0.23
2003/03/12	12:42:40	0.000	0.28
2003/03/12	12:42:45	0.000	0.23
2003/03/12	12:42:50	0.000	0.25
2003/03/12	12:42:55	0.000	0.24
2003/03/12	12:43:00	0.000	0.25
2003/03/12	12:43:05	0.000	0.27
2003/03/12	12:43:10	0.000	0.24
2003/03/12	12:43:15	0.000	0.28
2003/03/12	12:43:20	0.000	0.28
2003/03/12	12:43:25	0.000	0.27
2003/03/12	12:43:30	0.000	0.25
2003/03/12	12:43:35	0.000	0.29
2003/03/12	12:43:40	0.000	0.29
2003/03/12	12:43:45	0.000	0.25
2003/03/12	12:43:50	0.000	0.30
2003/03/12	12:43:55	0.000	0.28
2003/03/12	12:44:00	0.000	0.28
2003/03/12	12:44:05	0.000	0.29
2003/03/12	12:44:10	0.000	0.27
2003/03/12	12:44:15	0.000	0.29
2003/03/12	12:44:20	0.000	0.29
2003/03/12	12:44:25	0.000	0.31
2003/03/12	12:44:30	0.000	0.31
2003/03/12	12:44:35	0.000	0.31
2003/03/12	12:44:40	0.000	0.32
2003/03/12	12:44:45	0.000	0.34
2003/03/12	12:44:50	0.000	0.33
2003/03/12	12:44:55	0.000	0.30
2003/03/12	12:45:00	0.000	0.36
2003/03/12	12:45:05	0.000	0.33
2003/03/12	12:45:10	0.000	0.32
2003/03/12	12:45:15	0.000	0.38
2003/03/12	12:45:20	0.000	0.33
2003/03/12	12:45:25	0.000	0.35
2003/03/12	12:45:30	0.000	0.34
2003/03/12	12:45:35	0.000	0.38
2003/03/12	12:45:40	0.000	0.37
2003/03/12	12:45:45	0.000	0.35
2003/03/12	12:45:50	0.000	0.39
2003/03/12	12:45:55	0.000	0.40
2003/03/12	12:46:00	0.000	0.39
2003/03/12	12:46:05	0.000	0.39
2003/03/12	12:46:10	0.000	0.43
2003/03/12	12:46:15	0.000	0.42
2003/03/12	12:46:20	0.000	0.39
2003/03/12	12:46:25	0.000	0.44
2003/03/12	12:46:30	0.000	0.40
2003/03/12	12:46:35	0.000	0.42
2003/03/12	12:46:40	0.000	0.43
2003/03/12	12:46:45	0.000	0.42
2003/03/12	12:46:50	0.000	0.46
2003/03/12	12:46:55	0.000	0.43
2003/03/12	12:47:00	0.000	0.45
2003/03/12	12:47:05	0.000	0.45
2003/03/12	12:47:10	0.000	0.46
2003/03/12	12:47:15	0.000	0.47
2003/03/12	12:47:20	0.000	0.48
2003/03/12	12:47:25	0.000	0.47
2003/03/12	12:47:30	0.000	0.45
2003/03/12	12:47:35	0.000	0.61
2003/03/12	12:47:40	0.000	0.48
2003/03/12	12:47:45	0.000	0.47
2003/03/12	12:47:50	0.000	0.51
2003/03/12	12:47:55	0.000	0.48
2003/03/12	12:48:00	0.000	0.50
2003/03/12	12:48:05	0.000	0.48
2003/03/12	12:48:10	0.000	0.50
2003/03/12	12:48:15	0.000	0.51
2003/03/12	12:48:20	0.000	0.60
2003/03/12	12:48:25	0.000	0.63
2003/03/12	12:48:30	0.000	0.54
2003/03/12	12:48:35	0.000	0.63
2003/03/12	12:48:40	0.000	0.63
2003/03/12	12:48:45	0.000	0.57
2003/03/12	12:48:50	0.000	0.55
2003/03/12	12:48:55	0.000	0.63
2003/03/12	12:49:00	0.000	0.68
2003/03/12	12:49:05	0.000	0.54
2003/03/12	12:49:10	0.000	0.58
2003/03/12	12:49:15	0.000	0.57
2003/03/12	12:49:20	0.000	0.57
2003/03/12	12:49:25	0.000	0.60
2003/03/12	12:49:30	0.000	0.67
2003/03/12	12:49:35	0.000	0.60
2003/03/12	12:49:40	0.000	0.60

0.11

RESERVED FOR USE

0.23

RESERVED FOR USE

2003/03/12	12:48:45	0.000	0.60
2003/03/12	12:48:50	0.000	0.61
2003/03/12	12:48:55	0.000	0.63
2003/03/12	12:50:00	0.000	0.61
2003/03/12	12:50:05	0.000	0.60
2003/03/12	12:50:10	0.000	0.65
2003/03/12	12:50:15	0.000	0.63
2003/03/12	12:50:20	0.000	0.62
2003/03/12	12:50:25	0.000	0.68
2003/03/12	12:50:30	0.000	0.63
2003/03/12	12:50:35	0.000	0.68
2003/03/12	12:50:40	0.000	0.65
2003/03/12	12:50:45	0.000	0.67
2003/03/12	12:50:50	0.000	0.68
2003/03/12	12:50:55	0.000	0.68
2003/03/12	12:51:00	0.000	0.69
2003/03/12	12:51:05	0.000	0.70
2003/03/12	12:51:10	0.000	0.69
2003/03/12	12:51:15	0.000	0.68
2003/03/12	12:51:20	0.000	0.71
2003/03/12	12:51:25	0.000	0.69
2003/03/12	12:51:30	0.000	0.67
2003/03/12	12:51:35	0.000	0.72
2003/03/12	12:51:40	0.000	0.68
2003/03/12	12:51:45	0.000	0.70
2003/03/12	12:51:50	0.000	0.71
2003/03/12	12:51:55	0.000	0.70
2003/03/12	12:52:00	0.000	0.72
2003/03/12	12:52:05	0.000	0.70
2003/03/12	12:52:10	0.000	0.73
2003/03/12	12:52:15	0.000	0.74
2003/03/12	12:52:20	0.000	0.74
2003/03/12	12:52:25	0.000	0.78
2003/03/12	12:52:30	0.000	0.78
2003/03/12	12:52:35	0.000	0.77
2003/03/12	12:52:40	0.000	0.76
2003/03/12	12:52:45	0.000	0.80
2003/03/12	12:52:50	0.000	0.77
2003/03/12	12:52:55	0.000	0.77
2003/03/12	12:53:00	0.000	0.80
2003/03/12	12:53:05	0.000	0.78
2003/03/12	12:53:10	0.000	0.79
2003/03/12	12:53:15	0.000	0.77
2003/03/12	12:53:20	0.000	0.79
2003/03/12	12:53:25	0.000	0.80
2003/03/12	12:53:30	0.000	0.78
2003/03/12	12:53:35	0.000	0.77
2003/03/12	12:53:40	0.000	0.69
2003/03/12	12:53:45	0.000	0.54
2003/03/12	12:53:50	0.000	0.39
2003/03/12	12:53:55	0.000	0.33
2003/03/12	12:54:00	0.000	0.26
2003/03/12	12:54:05	0.000	0.18
2003/03/12	12:54:10	0.000	0.16
2003/03/12	12:54:15	0.000	0.08
2003/03/12	12:54:20	0.000	0.08
2003/03/12	12:54:25	0.000	0.03
2003/03/12	12:54:30	0.000	0.03
2003/03/12	12:54:35	0.000	0.08
2003/03/12	12:54:40	0.000	0.15
2003/03/12	12:54:45	0.000	0.32
2003/03/12	12:54:50	0.000	0.44
2003/03/12	12:54:55	0.000	0.55
2003/03/12	12:55:00	0.000	0.64
2003/03/12	12:55:05	0.000	0.71
2003/03/12	12:55:10	0.000	0.72
2003/03/12	12:55:15	0.000	0.70
2003/03/12	12:55:20	0.000	0.74
2003/03/12	12:55:25	0.000	0.62
2003/03/12	12:55:30	0.000	0.48
2003/03/12	12:55:35	0.000	0.38
2003/03/12	12:55:40	0.000	0.27
2003/03/12	12:55:45	0.000	0.22
2003/03/12	12:55:50	0.000	0.15
2003/03/12	12:55:55	0.000	0.13
2003/03/12	12:56:00	0.000	0.10
2003/03/12	12:56:05	0.000	0.08
2003/03/12	12:56:10	0.000	0.07
2003/03/12	12:56:15	0.000	0.05
2003/03/12	12:56:20	0.000	0.03
2003/03/12	12:56:25	0.000	0.01
2003/03/12	12:56:30	0.000	0.05
2003/03/12	12:56:35	0.000	0.03
2003/03/12	12:56:40	0.000	-0.01
2003/03/12	12:56:45	0.000	0.04
2003/03/12	12:56:50	0.000	-0.01
2003/03/12	12:56:55	0.000	0.01
2003/03/12	12:57:00	0.000	0.00
2003/03/12	12:57:05	0.000	0.00
2003/03/12	12:57:10	0.000	0.01
2003/03/12	12:57:15	0.000	-0.01
2003/03/12	12:57:20	0.000	0.02
2003/03/12	12:57:25	0.000	0.00
2003/03/12	12:57:30	0.000	0.00
2003/03/12	12:57:35	0.000	0.02
2003/03/12	12:57:40	0.000	0.04
2003/03/12	12:57:45	0.000	0.03
2003/03/12	12:57:50	0.000	0.01
2003/03/12	12:57:55	0.000	0.07
2003/03/12	12:58:00	0.000	0.04
2003/03/12	12:58:05	0.000	0.05
2003/03/12	12:58:10	0.000	0.08
2003/03/12	12:58:15	0.000	0.06
2003/03/12	12:58:20	0.000	0.08
2003/03/12	12:58:25	0.000	0.07
2003/03/12	12:58:30	0.000	0.10
2003/03/12	12:58:35	0.000	0.10
2003/03/12	12:58:40	0.000	0.09
2003/03/12	12:58:45	0.000	0.12
2003/03/12	12:58:50	0.000	0.12
2003/03/12	12:58:55	0.000	0.10
2003/03/12	12:59:00	0.000	0.08
2003/03/12	12:59:05	0.000	0.12
2003/03/12	12:59:10	0.000	0.10
2003/03/12	12:59:15	0.000	0.07
2003/03/12	12:59:20	0.000	0.11
2003/03/12	12:59:25	0.000	0.06
2003/03/12	12:59:30	0.000	0.06
2003/03/12	12:59:35	0.000	0.08
2003/03/12	12:59:40	0.000	0.08
2003/03/12	12:59:45	0.000	0.10
2003/03/12	12:59:50	0.000	0.06
2003/03/12	12:59:55	0.000	0.09
2003/03/12	13:00:00	0.000	0.08
2003/03/12	13:00:05	0.000	0.08
2003/03/12	13:00:10	0.000	0.09
2003/03/12	13:00:15	0.000	0.10
2003/03/12	13:00:20	0.000	0.08
2003/03/12	13:00:25	0.000	0.06
2003/03/12	13:00:30	0.000	0.10
2003/03/12	13:00:35	0.000	0.07
2003/03/12	13:00:40	0.000	0.09
2003/03/12	13:00:45	0.000	0.09
2003/03/12	13:00:50	0.000	0.08

0.47

████████████████████

0.69

████████████████████

0.14

████████████████████

2003/03/12	13:00:55	0.000	0.08
2003/03/12	13:01:00	0.000	0.08
2003/03/12	13:01:05	0.000	0.08
2003/03/12	13:01:10	0.000	0.08
2003/03/12	13:01:15	0.000	0.08
2003/03/12	13:01:20	0.000	0.08
2003/03/12	13:01:25	0.000	0.10
2003/03/12	13:01:30	0.000	0.08
2003/03/12	13:01:35	0.000	0.08
2003/03/12	13:01:40	0.000	0.10
2003/03/12	13:01:45	0.000	0.08
2003/03/12	13:01:50	0.000	0.08
2003/03/12	13:01:55	0.000	0.11
2003/03/12	13:02:00	0.000	0.08
2003/03/12	13:02:05	0.000	0.08
2003/03/12	13:02:10	0.000	0.08
2003/03/12	13:02:15	0.000	0.08
2003/03/12	13:02:20	0.000	0.10
2003/03/12	13:02:25	0.000	0.07
2003/03/12	13:02:30	0.000	0.09
2003/03/12	13:02:35	0.000	0.10
2003/03/12	13:02:40	0.000	0.10
2003/03/12	13:02:45	0.000	0.11
2003/03/12	13:02:50	0.000	0.12
2003/03/12	13:02:55	0.000	0.12
2003/03/12	13:03:00	0.000	0.08
2003/03/12	13:03:05	0.000	0.14
2003/03/12	13:03:10	0.000	0.11
2003/03/12	13:03:15	0.000	0.11
2003/03/12	13:03:20	0.000	0.14
2003/03/12	13:03:25	0.000	0.11
2003/03/12	13:03:30	0.000	0.13
2003/03/12	13:03:35	0.000	0.11
2003/03/12	13:03:40	0.000	0.14
2003/03/12	13:03:45	0.000	0.14
2003/03/12	13:03:50	0.000	0.12
2003/03/12	13:03:55	0.000	0.15
2003/03/12	13:04:00	0.000	0.17
2003/03/12	13:04:05	0.000	0.15
2003/03/12	13:04:10	0.000	0.14
2003/03/12	13:04:15	0.000	0.18
2003/03/12	13:04:20	0.000	0.17
2003/03/12	13:04:25	0.000	0.16
2003/03/12	13:04:30	0.000	0.19
2003/03/12	13:04:35	0.000	0.14
2003/03/12	13:04:40	0.000	0.17
2003/03/12	13:04:45	0.000	0.17
2003/03/12	13:04:50	0.000	0.17
2003/03/12	13:04:55	0.000	0.18
2003/03/12	13:05:00	0.000	0.18
2003/03/12	13:05:05	0.000	0.19
2003/03/12	13:05:10	0.000	0.18
2003/03/12	13:05:15	0.000	0.18
2003/03/12	13:05:20	0.000	0.18
2003/03/12	13:05:25	0.000	0.20
2003/03/12	13:05:30	0.000	0.18
2003/03/12	13:05:35	0.000	0.16
2003/03/12	13:05:40	0.000	0.20
2003/03/12	13:05:45	0.000	0.18
2003/03/12	13:05:50	0.000	0.18
2003/03/12	13:05:55	0.000	0.18
2003/03/12	13:06:00	0.000	0.15
2003/03/12	13:06:05	0.000	0.17
2003/03/12	13:06:10	0.000	0.15
2003/03/12	13:06:15	0.000	0.17
2003/03/12	13:06:20	0.000	0.17
2003/03/12	13:06:25	0.000	0.15
2003/03/12	13:06:30	0.000	0.19
2003/03/12	13:06:35	0.000	0.19
2003/03/12	13:06:40	0.000	0.17
2003/03/12	13:06:45	0.000	0.18
2003/03/12	13:06:50	0.000	0.20
2003/03/12	13:06:55	0.000	0.18
2003/03/12	13:07:00	0.000	0.15
2003/03/12	13:07:05	0.000	0.19
2003/03/12	13:07:10	0.000	0.15
2003/03/12	13:07:15	0.000	0.18
2003/03/12	13:07:20	0.000	0.17
2003/03/12	13:07:25	0.000	0.17
2003/03/12	13:07:30	0.000	0.18
2003/03/12	13:07:35	0.000	0.17
2003/03/12	13:07:40	0.000	0.20
2003/03/12	13:07:45	0.000	0.19
2003/03/12	13:07:50	0.000	0.19
2003/03/12	13:07:55	0.000	0.20
2003/03/12	13:08:00	0.000	0.21
2003/03/12	13:08:05	0.000	0.20
2003/03/12	13:08:10	0.000	0.18
2003/03/12	13:08:15	0.000	0.23
2003/03/12	13:08:20	0.000	0.20
2003/03/12	13:08:25	0.000	0.21
2003/03/12	13:08:30	0.000	0.23
2003/03/12	13:08:35	0.000	0.22
2003/03/12	13:08:40	0.000	0.25
2003/03/12	13:08:45	0.000	0.23
2003/03/12	13:08:50	0.000	0.28
2003/03/12	13:08:55	0.000	0.28
2003/03/12	13:09:00	0.000	0.24
2003/03/12	13:09:05	0.000	0.27
2003/03/12	13:09:10	0.000	0.28
2003/03/12	13:09:15	0.000	0.28
2003/03/12	13:09:20	0.000	0.24
2003/03/12	13:09:25	0.000	0.29
2003/03/12	13:09:30	0.000	0.27
2003/03/12	13:09:35	0.000	0.24
2003/03/12	13:09:40	0.000	0.28
2003/03/12	13:09:45	0.000	0.24
2003/03/12	13:09:50	0.000	0.27
2003/03/12	13:09:55	0.000	0.25
2003/03/12	13:10:00	0.000	0.29
2003/03/12	13:10:05	0.000	0.28
2003/03/12	13:10:10	0.000	0.24
2003/03/12	13:10:15	0.000	0.27
2003/03/12	13:10:20	0.000	0.28
2003/03/12	13:10:25	0.000	0.28
2003/03/12	13:10:30	0.000	0.28
2003/03/12	13:10:35	0.000	0.28
2003/03/12	13:10:40	0.000	0.28
2003/03/12	13:10:45	0.000	0.23
2003/03/12	13:10:50	0.000	0.28
2003/03/12	13:10:55	0.000	0.24
2003/03/12	13:11:00	0.000	0.25
2003/03/12	13:11:05	0.000	0.29
2003/03/12	13:11:10	0.000	0.24
2003/03/12	13:11:15	0.000	0.29
2003/03/12	13:11:20	0.000	0.24
2003/03/12	13:11:25	0.000	0.27
2003/03/12	13:11:30	0.000	0.27
2003/03/12	13:11:35	0.000	0.25
2003/03/12	13:11:40	0.000	0.28
2003/03/12	13:11:45	0.000	0.29
2003/03/12	13:11:50	0.000	0.28
2003/03/12	13:11:55	0.000	0.25
2003/03/12	13:12:00	0.000	0.29

0.11

XXXXXXXXXXXXXXXXXXXX

0.20

XXXXXXXXXXXXXXXXXXXX

2003/03/12	13:12:05	0.000	0.27
2003/03/12	13:12:10	0.000	0.28
2003/03/12	13:12:15	0.000	0.29
2003/03/12	13:12:20	0.000	0.24
2003/03/12	13:12:25	0.000	0.27
2003/03/12	13:12:30	0.000	0.28
2003/03/12	13:12:35	0.000	0.28
2003/03/12	13:12:40	0.000	0.27
2003/03/12	13:12:45	0.000	0.21
2003/03/12	13:12:50	0.000	0.18
2003/03/12	13:12:55	0.000	0.14
2003/03/12	13:13:00	0.000	0.10
2003/03/12	13:13:05	0.000	0.07
2003/03/12	13:13:10	0.000	0.07
2003/03/12	13:13:15	0.000	0.06
2003/03/12	13:13:20	0.000	0.01
2003/03/12	13:13:25	0.000	0.06
2003/03/12	13:13:30	0.000	0.02
2003/03/12	13:13:35	0.000	0.07
2003/03/12	13:13:40	0.000	0.10
2003/03/12	13:13:45	0.000	0.07
2003/03/12	13:13:50	0.000	0.08
2003/03/12	13:13:55	0.000	0.02
2003/03/12	13:14:00	0.000	0.04
2003/03/12	13:14:05	0.000	0.03
2003/03/12	13:14:10	0.000	0.01
2003/03/12	13:14:15	0.000	0.02
2003/03/12	13:14:20	0.000	0.03
2003/03/12	13:14:25	0.000	0.01
2003/03/12	13:14:30	0.000	-0.01
2003/03/12	13:14:35	0.000	0.03
2003/03/12	13:14:40	0.000	0.01
2003/03/12	13:14:45	0.000	-0.01
2003/03/12	13:14:50	0.000	0.04
2003/03/12	13:14:55	0.000	0.01
2003/03/12	13:15:00	0.000	0.04
2003/03/12	13:15:05	0.000	0.04
2003/03/12	13:15:10	0.000	0.09
2003/03/12	13:15:15	0.000	0.09
2003/03/12	13:15:20	0.000	0.09
2003/03/12	13:15:25	0.000	0.13
2003/03/12	13:15:30	0.000	0.14
2003/03/12	13:15:35	0.000	0.14
2003/03/12	13:15:40	0.000	0.14
2003/03/12	13:15:45	0.000	0.18
2003/03/12	13:15:50	0.000	0.17
2003/03/12	13:15:55	0.000	0.14
2003/03/12	13:16:00	0.000	0.19
2003/03/12	13:16:05	0.000	0.18
2003/03/12	13:16:10	0.000	0.18
2003/03/12	13:16:15	0.000	0.19
2003/03/12	13:16:20	0.000	0.16
2003/03/12	13:16:25	0.000	0.17
2003/03/12	13:16:30	0.000	0.15
2003/03/12	13:16:35	0.000	0.18
2003/03/12	13:16:40	0.000	0.18
2003/03/12	13:16:45	0.000	0.17
2003/03/12	13:16:50	0.000	0.20
2003/03/12	13:16:55	0.000	0.20
2003/03/12	13:17:00	0.000	0.19
2003/03/12	13:17:05	0.000	0.18
2003/03/12	13:17:10	0.000	0.21
2003/03/12	13:17:15	0.000	0.19
2003/03/12	13:17:20	0.000	0.17
2003/03/12	13:17:25	0.000	0.20
2003/03/12	13:17:30	0.000	0.16
2003/03/12	13:17:35	0.000	0.19
2003/03/12	13:17:40	0.000	0.17
2003/03/12	13:17:45	0.000	0.18
2003/03/12	13:17:50	0.000	0.18
2003/03/12	13:17:55	0.000	0.17
2003/03/12	13:18:00	0.000	0.20
2003/03/12	13:18:05	0.000	0.19
2003/03/12	13:18:10	0.000	0.19
2003/03/12	13:18:15	0.000	0.19
2003/03/12	13:18:20	0.000	0.21
2003/03/12	13:18:25	0.000	0.20
2003/03/12	13:18:30	0.000	0.17
2003/03/12	13:18:35	0.000	0.22
2003/03/12	13:18:40	0.000	0.18
2003/03/12	13:18:45	0.000	0.19
2003/03/12	13:18:50	0.000	0.19
2003/03/12	13:18:55	0.000	0.18
2003/03/12	13:19:00	0.000	0.20
2003/03/12	13:19:05	0.000	0.17
2003/03/12	13:19:10	0.000	0.20
2003/03/12	13:19:15	0.000	0.20
2003/03/12	13:19:20	0.000	0.19
2003/03/12	13:19:25	0.000	0.21
2003/03/12	13:19:30	0.000	0.22
2003/03/12	13:19:35	0.000	0.23
2003/03/12	13:19:40	0.000	0.17
2003/03/12	13:19:45	0.000	0.22
2003/03/12	13:19:50	0.000	0.19
2003/03/12	13:19:55	0.000	0.18
2003/03/12	13:20:00	0.000	0.21
2003/03/12	13:20:05	0.000	0.17
2003/03/12	13:20:10	0.000	0.20
2003/03/12	13:20:15	0.000	0.18
2003/03/12	13:20:20	0.000	0.20
2003/03/12	13:20:25	0.000	0.21
2003/03/12	13:20:30	0.000	0.18
2003/03/12	13:20:35	0.000	0.20
2003/03/12	13:20:40	0.000	0.21
2003/03/12	13:20:45	0.000	0.20
2003/03/12	13:20:50	0.000	0.19
2003/03/12	13:20:55	0.000	0.22
2003/03/12	13:21:00	0.000	0.20
2003/03/12	13:21:05	0.000	0.17
2003/03/12	13:21:10	0.000	0.22
2003/03/12	13:21:15	0.000	0.18
2003/03/12	13:21:20	0.000	0.19
2003/03/12	13:21:25	0.000	0.20
2003/03/12	13:21:30	0.000	0.18
2003/03/12	13:21:35	0.000	0.20
2003/03/12	13:21:40	0.000	0.17
2003/03/12	13:21:45	0.000	0.20
2003/03/12	13:21:50	0.000	0.20
2003/03/12	13:21:55	0.000	0.19
2003/03/12	13:22:00	0.000	0.20
2003/03/12	13:22:05	0.000	0.21
2003/03/12	13:22:10	0.000	0.20
2003/03/12	13:22:15	0.000	0.17
2003/03/12	13:22:20	0.000	0.22
2003/03/12	13:22:25	0.000	0.19
2003/03/12	13:22:30	0.000	0.18
2003/03/12	13:22:35	0.000	0.22
2003/03/12	13:22:40	0.000	0.17
2003/03/12	13:22:45	0.000	0.20
2003/03/12	13:22:50	0.000	0.18
2003/03/12	13:22:55	0.000	0.19
2003/03/12	13:23:00	0.000	0.20
2003/03/12	13:23:05	0.000	0.18
2003/03/12	13:23:10	0.000	0.18

0.17

[REDACTED]

0.17

[REDACTED]

2003/03/12	13:23:15	0.000	0.18
2003/03/12	13:23:20	0.000	0.18
2003/03/12	13:23:25	0.000	0.17
2003/03/12	13:23:30	0.000	0.21
2003/03/12	13:23:35	0.000	0.20
2003/03/12	13:23:40	0.000	0.18
2003/03/12	13:23:45	0.000	0.21
2003/03/12	13:23:50	0.000	0.17
2003/03/12	13:23:55	0.000	0.18
2003/03/12	13:24:00	0.000	0.19
2003/03/12	13:24:05	0.000	0.18
2003/03/12	13:24:10	0.000	0.20
2003/03/12	13:24:15	0.000	0.17
2003/03/12	13:24:20	0.000	0.20
2003/03/12	13:24:25	0.000	0.20
2003/03/12	13:24:30	0.000	0.19
2003/03/12	13:24:35	0.000	0.20
2003/03/12	13:24:40	0.000	0.21
2003/03/12	13:24:45	0.000	0.20
2003/03/12	13:24:50	0.000	0.17
2003/03/12	13:24:55	0.000	0.22
2003/03/12	13:25:00	0.000	0.19
2003/03/12	13:25:05	0.000	0.17
2003/03/12	13:25:10	0.000	0.21
2003/03/12	13:25:15	0.000	0.18
2003/03/12	13:25:20	0.000	0.20
2003/03/12	13:25:25	0.000	0.18
2003/03/12	13:25:30	0.000	0.20
2003/03/12	13:25:35	0.000	0.20
2003/03/12	13:25:40	0.000	0.18
2003/03/12	13:25:45	0.000	0.21
2003/03/12	13:25:50	0.000	0.21
2003/03/12	13:25:55	0.000	0.20
2003/03/12	13:26:00	0.000	0.19
2003/03/12	13:26:05	0.000	0.23
2003/03/12	13:26:10	0.000	0.22
2003/03/12	13:26:15	0.000	0.18
2003/03/12	13:26:20	0.000	0.23
2003/03/12	13:26:25	0.000	0.19
2003/03/12	13:26:30	0.000	0.21
2003/03/12	13:26:35	0.000	0.21
2003/03/12	13:26:40	0.000	0.20
2003/03/12	13:26:45	0.000	0.21
2003/03/12	13:26:50	0.000	0.19
2003/03/12	13:26:55	0.000	0.22
2003/03/12	13:27:00	0.000	0.22
2003/03/12	13:27:05	0.000	0.21
2003/03/12	13:27:10	0.000	0.23
2003/03/12	13:27:15	0.000	0.24
2003/03/12	13:27:20	0.000	0.22
2003/03/12	13:27:25	0.000	0.19
2003/03/12	13:27:30	0.000	0.25
2003/03/12	13:27:35	0.000	0.21
2003/03/12	13:27:40	0.000	0.21
2003/03/12	13:27:45	0.000	0.24
2003/03/12	13:27:50	0.000	0.21
2003/03/12	13:27:55	0.000	0.23
2003/03/12	13:28:00	0.000	0.21
2003/03/12	13:28:05	0.000	0.23
2003/03/12	13:28:10	0.000	0.23
2003/03/12	13:28:15	0.000	0.21
2003/03/12	13:28:20	0.000	0.24
2003/03/12	13:28:25	0.000	0.25
2003/03/12	13:28:30	0.000	0.23
2003/03/12	13:28:35	0.000	0.22
2003/03/12	13:28:40	0.000	0.26
2003/03/12	13:28:45	0.000	0.24
2003/03/12	13:28:50	0.000	0.22
2003/03/12	13:28:55	0.000	0.26
2003/03/12	13:29:00	0.000	0.22
2003/03/12	13:29:05	0.000	0.24
2003/03/12	13:29:10	0.000	0.24
2003/03/12	13:29:15	0.000	0.24
2003/03/12	13:29:20	0.000	0.26
2003/03/12	13:29:25	0.000	0.22
2003/03/12	13:29:30	0.000	0.25
2003/03/12	13:29:35	0.000	0.25
2003/03/12	13:29:40	0.000	0.24
2003/03/12	13:29:45	0.000	0.24
2003/03/12	13:29:50	0.000	0.26
2003/03/12	13:29:55	0.000	0.24
2003/03/12	13:30:00	0.000	0.21
2003/03/12	13:30:05	0.000	0.24
2003/03/12	13:30:10	0.000	0.17
2003/03/12	13:30:15	0.000	0.13
2003/03/12	13:30:20	0.000	0.12
2003/03/12	13:30:25	0.000	0.08
2003/03/12	13:30:30	0.000	0.08
2003/03/12	13:30:35	0.000	0.02
2003/03/12	13:30:40	0.000	0.04
2003/03/12	13:30:45	0.000	0.03
2003/03/12	13:30:50	0.000	0.01
2003/03/12	13:30:55	0.000	0.02
2003/03/12	13:31:00	0.000	0.03
2003/03/12	13:31:05	0.000	0.04
2003/03/12	13:31:10	0.000	0.03
2003/03/12	13:31:15	0.000	0.09
2003/03/12	13:31:20	0.000	0.09
2003/03/12	13:31:25	0.000	0.07
2003/03/12	13:31:30	0.000	0.12
2003/03/12	13:31:35	0.000	0.07
2003/03/12	13:31:40	0.000	0.09
2003/03/12	13:31:45	0.000	0.08
2003/03/12	13:31:50	0.000	0.08
2003/03/12	13:31:55	0.000	0.07
2003/03/12	13:32:00	0.000	0.02
2003/03/12	13:32:05	0.000	0.04
2003/03/12	13:32:10	0.000	0.02
2003/03/12	13:32:15	0.000	0.02
2003/03/12	13:32:20	0.000	0.02
2003/03/12	13:32:25	0.600	0.03
2003/03/12	13:32:30	0.000	0.02
2003/03/12	13:32:35	0.000	-0.02
2003/03/12	13:32:40	0.000	0.03
2003/03/12	13:32:45	0.000	-0.01
2003/03/12	13:32:50	0.000	0.00
2003/03/12	13:32:55	0.000	0.02
2003/03/12	13:33:00	0.000	-0.01
2003/03/12	13:33:05	0.000	0.01
2003/03/12	13:33:10	0.000	-0.01
2003/03/12	13:33:15	0.000	0.01
2003/03/12	13:33:20	0.000	0.01
2003/03/12	13:33:25	0.000	-0.01
2003/03/12	13:33:30	0.000	0.01
2003/03/12	13:33:35	0.000	0.02
2003/03/12	13:33:40	0.000	0.01
2003/03/12	13:33:45	0.000	-0.01
2003/03/12	13:33:50	0.000	0.03
2003/03/12	13:33:55	0.000	0.02
2003/03/12	13:34:00	0.000	-0.01
2003/03/12	13:34:05	0.000	0.03
2003/03/12	13:34:10	0.000	-0.02
2003/03/12	13:34:15	0.000	0.00
2003/03/12	13:34:20	0.000	0.00

0.19

REMOVED HYDRO

0.22

REMOVED HYDRO

2003/03/12	13:34:26	0.000	0.00
2003/03/12	13:34:30	0.000	0.01
2003/03/12	13:34:36	0.000	-0.01
2003/03/12	13:34:40	0.000	0.02
2003/03/12	13:34:46	0.000	0.01
2003/03/12	13:34:50	0.000	0.01
2003/03/12	13:34:55	0.000	0.01
2003/03/12	13:35:00	0.000	0.03
2003/03/12	13:35:05	0.000	0.02
2003/03/12	13:35:10	0.000	-0.02
2003/03/12	13:35:16	0.000	0.03
2003/03/12	13:35:20	0.000	-0.01
2003/03/12	13:35:25	0.000	0.00
2003/03/12	13:35:30	0.000	0.01
2003/03/12	13:35:36	0.000	-0.01
2003/03/12	13:35:40	0.000	0.00
2003/03/12	13:35:46	0.000	-0.02
2003/03/12	13:35:50	0.000	0.01
2003/03/12	13:35:56	0.000	0.01
2003/03/12	13:36:00	0.000	0.00
2003/03/12	13:36:05	0.000	0.02
2003/03/12	13:36:10	0.000	0.02
2003/03/12	13:36:15	0.000	0.01
2003/03/12	13:36:20	0.000	-0.01
2003/03/12	13:36:26	0.000	0.03
2003/03/12	13:36:30	0.000	0.01
2003/03/12	13:36:36	0.000	-0.01
2003/03/12	13:36:40	0.000	0.03
2003/03/12	13:36:46	0.000	-0.01
2003/03/12	13:36:50	0.000	0.01
2003/03/12	13:36:56	0.000	-0.01
2003/03/12	13:37:00	0.000	0.00
2003/03/12	13:37:05	0.000	0.01
2003/03/12	13:37:10	0.000	-0.01
2003/03/12	13:37:16	0.000	0.02
2003/03/12	13:37:20	0.000	0.01
2003/03/12	13:37:26	0.000	0.01
2003/03/12	13:37:30	0.000	0.01
2003/03/12	13:37:36	0.000	0.03
2003/03/12	13:37:40	0.000	0.01
2003/03/12	13:37:46	0.000	-0.02
2003/03/12	13:37:50	0.000	0.03
2003/03/12	13:37:56	0.000	-0.01
2003/03/12	13:38:00	0.000	0.00
2003/03/12	13:38:06	0.000	0.01
2003/03/12	13:38:10	0.000	-0.01
2003/03/12	13:38:16	0.000	0.01
2003/03/12	13:38:20	0.000	-0.02
2003/03/12	13:38:26	0.000	0.01
2003/03/12	13:38:30	0.000	0.01
2003/03/12	13:38:36	0.000	0.00
2003/03/12	13:38:40	0.000	0.02
2003/03/12	13:38:46	0.000	0.03
2003/03/12	13:38:50	0.000	0.01
2003/03/12	13:38:56	0.000	-0.01
2003/03/12	13:39:00	0.000	0.03
2003/03/12	13:39:06	0.000	0.01
2003/03/12	13:39:10	0.000	-0.01
2003/03/12	13:39:16	0.000	0.03
2003/03/12	13:39:20	0.000	-0.01
2003/03/12	13:39:26	0.000	0.01
2003/03/12	13:39:30	0.000	-0.01
2003/03/12	13:39:36	0.000	0.01
2003/03/12	13:39:40	0.000	0.02
2003/03/12	13:39:46	0.000	-0.01
2003/03/12	13:39:50	0.000	0.01
2003/03/12	13:39:56	0.000	0.01
2003/03/12	13:40:00	0.000	0.01
2003/03/12	13:40:06	0.000	0.00
2003/03/12	13:40:10	0.000	0.03
2003/03/12	13:40:16	0.000	0.01
2003/03/12	13:40:20	0.000	-0.01
2003/03/12	13:40:26	0.000	0.03
2003/03/12	13:40:30	0.000	-0.01
2003/03/12	13:40:36	0.000	0.00
2003/03/12	13:40:40	0.000	0.01
2003/03/12	13:40:46	0.000	-0.01
2003/03/12	13:40:50	0.000	0.01
2003/03/12	13:40:56	0.000	-0.02
2003/03/12	13:41:00	0.000	0.01
2003/03/12	13:41:06	0.000	0.01
2003/03/12	13:41:10	0.000	0.00
2003/03/12	13:41:16	0.000	0.02
2003/03/12	13:41:20	0.000	0.03
2003/03/12	13:41:26	0.000	0.01
2003/03/12	13:41:30	0.000	-0.02
2003/03/12	13:41:36	0.000	0.03
2003/03/12	13:41:40	0.000	0.00
2003/03/12	13:41:46	0.000	-0.01
2003/03/12	13:41:50	0.000	0.02
2003/03/12	13:41:56	0.000	-0.01
2003/03/12	13:42:00	0.000	0.01
2003/03/12	13:42:06	0.000	-0.01
2003/03/12	13:42:10	0.000	0.01
2003/03/12	13:42:16	0.000	0.02
2003/03/12	13:42:20	0.000	-0.01
2003/03/12	13:42:26	0.000	0.01
2003/03/12	13:42:30	0.000	0.01
2003/03/12	13:42:36	0.000	0.01
2003/03/12	13:42:40	0.000	0.00
2003/03/12	13:42:46	0.000	0.03
2003/03/12	13:42:50	0.000	0.02
2003/03/12	13:42:56	0.000	-0.02
2003/03/12	13:43:00	0.000	0.03
2003/03/12	13:43:06	0.000	-0.01
2003/03/12	13:43:10	0.000	0.00
2003/03/12	13:43:16	0.000	0.01
2003/03/12	13:43:20	0.000	-0.01
2003/03/12	13:43:26	0.000	0.01
2003/03/12	13:43:30	0.000	-0.01
2003/03/12	13:43:36	0.000	0.02
2003/03/12	13:43:40	0.000	0.00
2003/03/12	13:43:46	0.000	0.00
2003/03/12	13:43:50	0.000	0.01
2003/03/12	13:43:56	0.000	0.02
2003/03/12	13:44:00	0.000	0.01
2003/03/12	13:44:06	0.000	-0.02
2003/03/12	13:44:10	0.000	0.03
2003/03/12	13:44:16	0.000	0.00
2003/03/12	13:44:20	0.000	-0.01
2003/03/12	13:44:26	0.000	0.02
2003/03/12	13:44:30	0.000	-0.01
2003/03/12	13:44:36	0.000	0.00
2003/03/12	13:44:40	0.000	-0.01
2003/03/12	13:44:46	0.000	0.01
2003/03/12	13:44:50	0.000	0.01
2003/03/12	13:44:56	0.000	-0.01
2003/03/12	13:45:00	0.000	0.02
2003/03/12	13:45:06	0.000	0.01
2003/03/12	13:45:10	0.000	0.01
2003/03/12	13:45:16	0.000	0.00
2003/03/12	13:45:20	0.000	0.03
2003/03/12	13:45:26	0.000	0.02
2003/03/12	13:45:30	0.000	-0.01

0.04

REPORTED TO/ISSUE

0.01

REPORTED TO/ISSUE

0.01

REPORTED TO/ISSUE

2003/03/12	13:48:35	0.000	0.08
2003/03/12	13:48:40	0.000	-0.01
2003/03/12	13:48:45	0.000	0.01
2003/03/12	13:48:50	0.000	0.00
2003/03/12	13:48:55	0.000	0.00
2003/03/12	13:49:00	0.000	0.01
2003/03/12	13:49:05	0.000	-0.01
2003/03/12	13:49:10	0.000	0.01
2003/03/12	13:49:15	0.000	0.00
2003/03/12	13:49:20	0.000	0.00
2003/03/12	13:49:25	0.000	0.02
2003/03/12	13:49:30	0.000	0.03
2003/03/12	13:49:35	0.000	0.01
2003/03/12	13:49:40	0.000	-0.02
2003/03/12	13:49:45	0.000	0.03
2003/03/12	13:49:50	0.000	0.00
2003/03/12	13:49:55	0.000	-0.01
2003/03/12	13:50:00	0.000	0.02
2003/03/12	13:50:05	0.000	-0.01
2003/03/12	13:50:10	0.000	0.03
2003/03/12	13:50:15	0.000	-0.02
2003/03/12	13:50:20	0.000	0.01
2003/03/12	13:50:25	0.000	0.00
2003/03/12	13:50:30	0.000	0.03
2003/03/12	13:50:35	0.000	0.01
2003/03/12	13:50:40	0.000	-0.01
2003/03/12	13:50:45	0.000	0.03
2003/03/12	13:50:50	0.000	-0.02
2003/03/12	13:50:55	0.000	0.01
2003/03/12	13:51:00	0.000	0.00
2003/03/12	13:51:05	0.000	0.00
2003/03/12	13:51:10	0.000	0.02
2003/03/12	13:51:15	0.000	-0.01
2003/03/12	13:51:20	0.000	0.01
2003/03/12	13:51:25	0.000	0.01
2003/03/12	13:51:30	0.000	0.01
2003/03/12	13:51:35	0.000	0.01
2003/03/12	13:51:40	0.000	0.03
2003/03/12	13:51:45	0.000	0.02
2003/03/12	13:51:50	0.000	-0.02
2003/03/12	13:51:55	0.000	0.03
2003/03/12	13:52:00	0.000	-0.01
2003/03/12	13:52:05	0.000	0.00
2003/03/12	13:52:10	0.000	0.02
2003/03/12	13:52:15	0.000	-0.01
2003/03/12	13:52:20	0.000	0.01
2003/03/12	13:52:25	0.000	-0.01
2003/03/12	13:52:30	0.000	0.01
2003/03/12	13:52:35	0.000	0.01
2003/03/12	13:52:40	0.000	-0.01
2003/03/12	13:52:45	0.000	0.01
2003/03/12	13:52:50	0.000	0.02
2003/03/12	13:52:55	0.000	0.01
2003/03/12	13:53:00	0.000	-0.01
2003/03/12	13:53:05	0.000	0.03
2003/03/12	13:53:10	0.000	0.02
2003/03/12	13:53:15	0.000	-0.01
2003/03/12	13:53:20	0.000	0.03
2003/03/12	13:53:25	0.000	-0.02
2003/03/12	13:53:30	0.000	0.00
2003/03/12	13:53:35	0.000	0.00
2003/03/12	13:53:40	0.000	0.00
2003/03/12	13:53:45	0.000	0.01
2003/03/12	13:53:50	0.000	-0.01
2003/03/12	13:53:55	0.000	0.02
2003/03/12	13:54:00	0.000	0.01
2003/03/12	13:54:05	0.000	0.01
2003/03/12	13:54:10	0.000	0.01
2003/03/12	13:54:15	0.000	0.03
2003/03/12	13:54:20	0.000	0.02
2003/03/12	13:54:25	0.000	-0.02
2003/03/12	13:54:30	0.000	0.03
2003/03/12	13:54:35	0.000	-0.01
2003/03/12	13:54:40	0.000	0.00
2003/03/12	13:54:45	0.000	0.01
2003/03/12	13:54:50	0.000	-0.01
2003/03/12	13:54:55	0.000	0.00
2003/03/12	13:55:00	0.000	-0.02
2003/03/12	13:55:05	0.000	0.01
2003/03/12	13:55:10	0.000	0.01
2003/03/12	13:55:15	0.000	0.00
2003/03/12	13:55:20	0.000	0.02
2003/03/12	13:55:25	0.000	0.03
2003/03/12	13:55:30	0.000	0.01
2003/03/12	13:55:35	0.000	-0.01
2003/03/12	13:55:40	0.000	0.03
2003/03/12	13:55:45	0.000	0.01
2003/03/12	13:55:50	0.000	-0.01
2003/03/12	13:55:55	0.000	0.03
2003/03/12	13:56:00	0.000	-0.01
2003/03/12	13:56:05	0.000	0.01
2003/03/12	13:56:10	0.000	0.01
2003/03/12	13:56:15	0.000	0.00
2003/03/12	13:56:20	0.000	0.02
2003/03/12	13:56:25	0.000	0.03
2003/03/12	13:56:30	0.000	0.01
2003/03/12	13:56:35	0.000	-0.01
2003/03/12	13:56:40	0.000	0.03
2003/03/12	13:56:45	0.000	0.01
2003/03/12	13:56:50	0.000	-0.01
2003/03/12	13:56:55	0.000	0.03
2003/03/12	13:57:00	0.000	-0.01
2003/03/12	13:57:05	0.000	0.01
2003/03/12	13:57:10	0.000	-0.01
2003/03/12	13:57:15	0.000	0.00
2003/03/12	13:57:20	0.000	0.01
2003/03/12	13:57:25	0.000	-0.01
2003/03/12	13:57:30	0.000	0.02
2003/03/12	13:57:35	0.000	0.01
2003/03/12	13:57:40	0.000	0.01

0.01

████████████████████

0.01

████████████████████

2003/03/12	13:58:46	0.000	0.01
2003/03/12	13:58:50	0.000	0.03
2003/03/12	13:58:55	0.000	0.01
2003/03/12	13:57:00	0.000	-0.02
2003/03/12	13:57:05	0.000	0.03
2003/03/12	13:57:10	0.000	-0.01
2003/03/12	13:57:15	0.000	0.00
2003/03/12	13:57:20	0.000	0.01
2003/03/12	13:57:25	0.000	-0.01
2003/03/12	13:57:30	0.000	0.01
2003/03/12	13:57:35	0.000	-0.02
2003/03/12	13:57:40	0.000	0.01
2003/03/12	13:57:45	0.000	0.01
2003/03/12	13:57:50	0.000	0.00
2003/03/12	13:57:55	0.000	0.02
2003/03/12	13:58:00	0.000	0.03
2003/03/12	13:58:05	0.000	0.01
2003/03/12	13:58:10	0.000	-0.01
2003/03/12	13:58:15	0.000	0.03
2003/03/12	13:58:20	0.000	0.00
2003/03/12	13:58:25	0.000	-0.01
2003/03/12	13:58:30	0.000	0.02
2003/03/12	13:58:35	0.000	-0.01
2003/03/12	13:58:40	0.000	0.01
2003/03/12	13:58:45	0.000	-0.01
2003/03/12	13:58:50	0.000	0.01
2003/03/12	13:58:55	0.000	0.02
2003/03/12	13:59:00	0.000	-0.01
2003/03/12	13:59:05	0.000	0.01
2003/03/12	13:59:10	0.000	0.01
2003/03/12	13:59:15	0.000	0.01
2003/03/12	13:59:20	0.000	0.00
2003/03/12	13:59:25	0.000	0.03
2003/03/12	13:59:30	0.000	0.01
2003/03/12	13:59:35	0.000	-0.01
2003/03/12	13:59:40	0.000	0.03
2003/03/12	13:59:45	0.000	-0.01
2003/03/12	13:59:50	0.000	0.00
2003/03/12	13:59:55	0.000	0.01
2003/03/12	14:00:00	0.000	-0.01
2003/03/12	14:00:05	0.000	0.02
2003/03/12	14:00:10	0.000	-0.02
2003/03/12	14:00:15	0.000	0.01
2003/03/12	14:00:20	0.000	0.01
2003/03/12	14:00:25	0.000	0.00
2003/03/12	14:00:30	0.000	0.02
2003/03/12	14:00:35	0.000	0.03
2003/03/12	14:00:40	0.000	0.02
2003/03/12	14:00:45	0.000	-0.01
2003/03/12	14:00:50	0.000	0.03
2003/03/12	14:00:55	0.000	0.00
2003/03/12	14:01:00	0.000	-0.01
2003/03/12	14:01:05	0.000	0.02
2003/03/12	14:01:10	0.000	-0.01
2003/03/12	14:01:15	0.000	0.01
2003/03/12	14:01:20	0.000	-0.01
2003/03/12	14:01:25	0.000	0.01
2003/03/12	14:01:30	0.000	0.02
2003/03/12	14:01:35	0.000	-0.01
2003/03/12	14:01:40	0.000	0.01
2003/03/12	14:01:45	0.000	0.02
2003/03/12	14:01:50	0.000	0.01
2003/03/12	14:01:55	0.000	0.00
2003/03/12	14:02:00	0.000	0.03
2003/03/12	14:02:05	0.000	0.02
2003/03/12	14:02:10	0.000	-0.01
2003/03/12	14:02:15	0.000	0.03
2003/03/12	14:02:20	0.000	-0.01
2003/03/12	14:02:25	0.000	0.01
2003/03/12	14:02:30	0.000	0.01
2003/03/12	14:02:35	0.000	0.00
2003/03/12	14:02:40	0.000	0.01
2003/03/12	14:02:45	0.000	-0.01
2003/03/12	14:02:50	0.000	0.02
2003/03/12	14:02:55	0.000	0.01
2003/03/12	14:03:00	0.000	0.00
2003/03/12	14:03:05	0.000	0.02
2003/03/12	14:03:10	0.000	0.04
2003/03/12	14:03:15	0.000	0.02
2003/03/12	14:03:20	0.000	-0.01
2003/03/12	14:03:25	0.000	0.04
2003/03/12	14:03:30	0.000	0.02
2003/03/12	14:03:35	0.000	0.01
2003/03/12	14:03:40	0.000	0.04
2003/03/12	14:03:45	0.000	0.00
2003/03/12	14:03:50	0.000	0.02
2003/03/12	14:03:55	0.000	0.00
2003/03/12	14:04:00	0.000	0.02
2003/03/12	14:04:05	0.000	0.03
2003/03/12	14:04:10	0.000	0.01
2003/03/12	14:04:15	0.000	0.04
2003/03/12	14:04:20	0.000	0.03
2003/03/12	14:04:25	0.000	0.03
2003/03/12	14:04:30	0.000	0.01
2003/03/12	14:04:35	0.000	0.05
2003/03/12	14:04:40	0.000	0.04
2003/03/12	14:04:45	0.000	0.01
2003/03/12	14:04:50	0.000	0.05
2003/03/12	14:04:55	0.000	0.01
2003/03/12	14:05:00	0.000	0.03
2003/03/12	14:05:05	0.000	0.03
2003/03/12	14:05:10	0.000	0.02
2003/03/12	14:05:15	0.000	0.03
2003/03/12	14:05:20	0.000	0.01
2003/03/12	14:05:25	0.000	0.04
2003/03/12	14:05:30	0.000	0.03
2003/03/12	14:05:35	0.000	0.03
2003/03/12	14:05:40	0.000	0.05
2003/03/12	14:05:45	0.000	0.05
2003/03/12	14:05:50	0.000	0.04
2003/03/12	14:05:55	0.000	0.01
2003/03/12	14:06:00	0.000	0.06
2003/03/12	14:06:05	0.000	0.03
2003/03/12	14:06:10	0.000	0.02
2003/03/12	14:06:15	0.000	0.06
2003/03/12	14:06:20	0.000	0.02
2003/03/12	14:06:25	0.000	0.04
2003/03/12	14:06:30	0.000	0.02
2003/03/12	14:06:35	0.000	0.03
2003/03/12	14:06:40	0.000	0.03
2003/03/12	14:06:45	0.000	0.00
2003/03/12	14:06:50	0.000	0.02
2003/03/12	14:06:55	0.000	0.02
2003/03/12	14:07:00	0.000	0.01
2003/03/12	14:07:05	0.000	0.00
2003/03/12	14:07:10	0.000	0.03
2003/03/12	14:07:15	0.000	0.01
2003/03/12	14:07:20	0.000	-0.01
2003/03/12	14:07:25	0.000	0.03
2003/03/12	14:07:30	0.000	-0.02
2003/03/12	14:07:35	0.000	0.00
2003/03/12	14:07:40	0.000	0.01
2003/03/12	14:07:45	0.000	0.02
2003/03/12	14:07:50	0.000	0.04

0.01

EXM000051 IMP000000

0.01

EXM000051 IMP000000

2003/03/12	14:07:55	0.000	0.01
2003/03/12	14:08:00	0.000	0.04
2003/03/12	14:08:05	0.000	0.03
2003/03/12	14:08:10	0.000	0.03
2003/03/12	14:08:15	0.000	0.04
2003/03/12	14:08:20	0.000	0.05
2003/03/12	14:08:25	0.000	0.02
2003/03/12	14:08:30	0.000	-0.01
2003/03/12	14:08:35	0.000	0.03
2003/03/12	14:08:40	0.000	0.00
2003/03/12	14:08:45	0.000	-0.01
2003/03/12	14:08:50	0.000	0.02
2003/03/12	14:08:55	0.000	-0.01
2003/03/12	14:09:00	0.000	0.01
2003/03/12	14:09:05	0.000	-0.01
2003/03/12	14:09:10	0.000	0.01
2003/03/12	14:09:15	0.000	0.01
2003/03/12	14:09:20	0.000	-0.01
2003/03/12	14:09:25	0.000	0.01
2003/03/12	14:09:30	0.000	0.02
2003/03/12	14:09:35	0.000	0.01
2003/03/12	14:09:40	0.000	-0.01
2003/03/12	14:09:45	0.000	0.03
2003/03/12	14:09:50	0.000	0.01
2003/03/12	14:09:55	0.000	-0.01
2003/03/12	14:10:00	0.000	0.03
2003/03/12	14:10:05	0.000	-0.02
2003/03/12	14:10:10	0.000	0.00
2003/03/12	14:10:15	0.000	0.00
2003/03/12	14:10:20	0.000	0.00
2003/03/12	14:10:25	0.000	0.02
2003/03/12	14:10:30	0.000	-0.01
2003/03/12	14:10:35	0.000	0.01
2003/03/12	14:10:40	0.000	0.00
2003/03/12	14:10:45	0.000	0.01
2003/03/12	14:10:50	0.000	0.01
2003/03/12	14:10:55	0.000	0.03
2003/03/12	14:11:00	0.000	0.02
2003/03/12	14:11:05	0.000	-0.02
2003/03/12	14:11:10	0.000	0.03
2003/03/12	14:11:15	0.000	0.00
2003/03/12	14:11:20	0.000	0.00
2003/03/12	14:11:25	0.000	0.02
2003/03/12	14:11:30	0.000	-0.01
2003/03/12	14:11:35	0.000	0.01
2003/03/12	14:11:40	0.000	-0.01
2003/03/12	14:11:45	0.000	0.01
2003/03/12	14:11:50	0.000	0.01
2003/03/12	14:11:55	0.000	-0.01
2003/03/12	14:12:00	0.000	0.01
2003/03/12	14:12:05	0.000	0.02
2003/03/12	14:12:10	0.000	0.01
2003/03/12	14:12:15	0.000	-0.01
2003/03/12	14:12:20	0.000	0.03
2003/03/12	14:12:25	0.000	0.02
2003/03/12	14:12:30	0.000	-0.01
2003/03/12	14:12:35	0.000	0.03
2003/03/12	14:12:40	0.000	-0.02
2003/03/12	14:12:45	0.000	0.00
2003/03/12	14:12:50	0.000	0.00
2003/03/12	14:12:55	0.000	0.00
2003/03/12	14:13:00	0.000	0.01
2003/03/12	14:13:05	0.000	-0.01
2003/03/12	14:13:10	0.000	0.02
2003/03/12	14:13:15	0.000	0.00
2003/03/12	14:13:20	0.000	0.01
2003/03/12	14:13:25	0.000	0.01
2003/03/12	14:13:30	0.000	0.03
2003/03/12	14:13:35	0.000	0.02
2003/03/12	14:13:40	0.000	-0.02
2003/03/12	14:13:45	0.000	0.03
2003/03/12	14:13:50	0.000	-0.01
2003/03/12	14:13:55	0.000	0.00
2003/03/12	14:14:00	0.000	0.02
2003/03/12	14:14:05	0.000	-0.01
2003/03/12	14:14:10	0.000	0.00
2003/03/12	14:14:15	0.000	-0.01
2003/03/12	14:14:20	0.000	0.01
2003/03/12	14:14:25	0.000	0.01
2003/03/12	14:14:30	0.000	-0.01
2003/03/12	14:14:35	0.000	0.02
2003/03/12	14:14:40	0.000	0.02
2003/03/12	14:14:45	0.000	0.01
2003/03/12	14:14:50	0.000	-0.01
2003/03/12	14:14:55	0.000	0.03
2003/03/12	14:15:00	0.000	0.01
2003/03/12	14:15:05	0.000	-0.01
2003/03/12	14:15:10	0.000	0.03
2003/03/12	14:15:15	0.000	-0.02
2003/03/12	14:15:20	0.000	0.01
2003/03/12	14:15:25	0.000	0.00
2003/03/12	14:15:30	0.000	0.00
2003/03/12	14:15:35	-0.000	0.01
2003/03/12	14:15:40	0.000	-0.01
2003/03/12	14:15:45	0.000	0.02
2003/03/12	14:15:50	0.000	0.00
2003/03/12	14:15:55	0.000	0.01
2003/03/12	14:16:00	0.000	0.01
2003/03/12	14:16:05	0.000	0.03
2003/03/12	14:16:10	0.000	0.01
2003/03/12	14:16:15	0.000	-0.02
2003/03/12	14:16:20	0.000	0.03
2003/03/12	14:16:25	0.000	-0.01
2003/03/12	14:16:30	0.000	0.00
2003/03/12	14:16:35	0.000	0.01
2003/03/12	14:16:40	0.000	-0.01
2003/03/12	14:16:45	0.000	0.01
2003/03/12	14:16:50	0.000	-0.02
2003/03/12	14:16:55	0.000	0.01
2003/03/12	14:17:00	0.000	0.01
2003/03/12	14:17:05	0.000	0.00
2003/03/12	14:17:10	0.000	0.02
2003/03/12	14:17:15	0.000	0.02
2003/03/12	14:17:20	0.000	0.01
2003/03/12	14:17:25	0.000	-0.01
2003/03/12	14:17:30	0.000	0.03
2003/03/12	14:17:35	0.000	0.01
2003/03/12	14:17:40	0.000	-0.01
2003/03/12	14:17:45	0.000	0.03
2003/03/12	14:17:50	0.000	-0.02
2003/03/12	14:17:55	0.000	0.01
2003/03/12	14:18:00	0.000	0.00
2003/03/12	14:18:05	0.000	0.00
2003/03/12	14:18:10	0.000	0.02
2003/03/12	14:18:15	0.000	-0.01
2003/03/12	14:18:20	0.000	0.01
2003/03/12	14:18:25	0.000	0.01
2003/03/12	14:18:30	0.000	0.01
2003/03/12	14:18:35	0.000	0.01
2003/03/12	14:18:40	0.000	0.03
2003/03/12	14:18:45	0.000	0.01
2003/03/12	14:18:50	0.000	-0.02
2003/03/12	14:18:55	0.000	0.03
2003/03/12	14:19:00	0.000	-0.01

0.02

0.02

0.01

0.01

2003/03/12	14:18:05	0.000	0.00
2003/03/12	14:18:10	0.000	0.01
2003/03/12	14:18:15	0.000	-0.01
2003/03/12	14:18:20	0.000	0.01
2003/03/12	14:18:25	0.000	-0.02
2003/03/12	14:18:30	0.000	0.01
2003/03/12	14:18:35	0.000	0.01
2003/03/12	14:18:40	0.000	0.00
2003/03/12	14:18:45	0.000	0.02
2003/03/12	14:18:50	0.000	0.02
2003/03/12	14:18:55	0.000	0.01
2003/03/12	14:20:00	0.000	-0.01
2003/03/12	14:20:05	0.000	0.03
2003/03/12	14:20:10	0.000	0.01
2003/03/12	14:20:15	0.000	-0.01
2003/03/12	14:20:20	0.000	0.03
2003/03/12	14:20:25	0.000	-0.02
2003/03/12	14:20:30	0.000	0.01
2003/03/12	14:20:35	0.000	0.00
2003/03/12	14:20:40	0.000	0.01
2003/03/12	14:20:45	0.000	0.02
2003/03/12	14:20:50	0.000	-0.01
2003/03/12	14:20:55	0.000	0.01
2003/03/12	14:21:00	0.000	0.01
2003/03/12	14:21:05	0.000	0.01
2003/03/12	14:21:10	0.000	0.00
2003/03/12	14:21:15	0.000	0.03
2003/03/12	14:21:20	0.000	0.02
2003/03/12	14:21:25	0.000	-0.02
2003/03/12	14:21:30	0.000	0.03
2003/03/12	14:21:35	0.000	-0.01
2003/03/12	14:21:40	0.000	0.00
2003/03/12	14:21:45	0.000	0.01
2003/03/12	14:21:50	0.000	-0.01
2003/03/12	14:21:55	0.000	0.01
2003/03/12	14:22:00	0.000	-0.01
2003/03/12	14:22:05	0.000	0.01
2003/03/12	14:22:10	0.000	0.01
2003/03/12	14:22:15	0.000	0.00
2003/03/12	14:22:20	0.000	0.01
2003/03/12	14:22:25	0.000	0.03
2003/03/12	14:22:30	0.000	0.01
2003/03/12	14:22:35	0.000	-0.02
2003/03/12	14:22:40	0.000	0.03
2003/03/12	14:22:45	0.000	0.01
2003/03/12	14:22:50	0.000	-0.01
2003/03/12	14:22:55	0.000	0.02
2003/03/12	14:23:00	0.000	-0.01
2003/03/12	14:23:05	0.000	0.00
2003/03/12	14:23:10	0.000	-0.01
2003/03/12	14:23:15	0.000	0.01
2003/03/12	14:23:20	0.000	0.01
2003/03/12	14:23:25	0.000	-0.01
2003/03/12	14:23:30	0.000	0.02
2003/03/12	14:23:35	0.000	0.01
2003/03/12	14:23:40	0.000	0.01
2003/03/12	14:23:45	0.000	0.00
2003/03/12	14:23:50	0.000	0.03
2003/03/12	14:23:55	0.000	0.02
2003/03/12	14:24:00	0.000	-0.02
2003/03/12	14:24:05	0.000	0.03
2003/03/12	14:24:10	0.000	-0.01
2003/03/12	14:24:15	0.000	0.00
2003/03/12	14:24:20	0.000	0.01
2003/03/12	14:24:25	0.000	-0.01
2003/03/12	14:24:30	0.000	0.00
2003/03/12	14:24:35	0.000	-0.02
2003/03/12	14:24:40	0.000	0.01
2003/03/12	14:24:45	0.000	0.00
2003/03/12	14:24:50	0.000	0.00
2003/03/12	14:24:55	0.000	0.02
2003/03/12	14:25:00	0.000	0.02
2003/03/12	14:25:05	0.000	0.01
2003/03/12	14:25:10	0.000	-0.02
2003/03/12	14:25:15	0.000	0.03
2003/03/12	14:25:20	0.000	0.00
2003/03/12	14:25:25	0.000	-0.01
2003/03/12	14:25:30	0.000	0.02
2003/03/12	14:25:35	0.000	-0.01
2003/03/12	14:25:40	0.000	0.01
2003/03/12	14:25:45	0.000	-0.01
2003/03/12	14:25:50	0.000	0.01
2003/03/12	14:25:55	0.000	0.01
2003/03/12	14:26:00	0.000	-0.01
2003/03/12	14:26:05	0.000	0.02
2003/03/12	14:26:10	0.000	0.01
2003/03/12	14:26:15	0.000	0.01
2003/03/12	14:26:20	0.000	0.00
2003/03/12	14:26:25	0.000	0.03
2003/03/12	14:26:30	0.000	0.01
2003/03/12	14:26:35	0.000	-0.01
2003/03/12	14:26:40	0.000	0.03
2003/03/12	14:26:45	0.000	-0.02
2003/03/12	14:26:50	0.000	0.00
2003/03/12	14:26:55	0.000	0.00
2003/03/12	14:27:00	0.000	0.00
2003/03/12	14:27:05	0.000	0.02
2003/03/12	14:27:10	0.000	-0.02
2003/03/12	14:27:15	0.000	0.01
2003/03/12	14:27:20	0.000	0.00
2003/03/12	14:27:25	0.000	0.00
2003/03/12	14:27:30	0.000	0.02
2003/03/12	14:27:35	0.000	0.03
2003/03/12	14:27:40	0.000	0.01
2003/03/12	14:27:45	0.000	-0.02
2003/03/12	14:27:50	0.000	0.03
2003/03/12	14:27:55	0.000	0.00
2003/03/12	14:28:00	0.000	-0.01
2003/03/12	14:28:05	0.000	0.02
2003/03/12	14:28:10	0.000	-0.01
2003/03/12	14:28:15	0.000	0.01
2003/03/12	14:28:20	0.000	-0.01
2003/03/12	14:28:25	0.000	-0.01
2003/03/12	14:28:30	0.000	0.01
2003/03/12	14:28:35	0.000	-0.01
2003/03/12	14:28:40	0.000	0.01
2003/03/12	14:28:45	0.000	0.01
2003/03/12	14:28:50	0.000	0.01
2003/03/12	14:28:55	0.000	-0.01
2003/03/12	14:29:00	0.000	0.03
2003/03/12	14:29:05	0.000	0.01
2003/03/12	14:29:10	0.000	-0.01
2003/03/12	14:29:15	0.000	0.03
2003/03/12	14:29:20	0.000	-0.02
2003/03/12	14:29:25	0.000	0.00
2003/03/12	14:29:30	0.000	0.00
2003/03/12	14:29:35	0.000	0.00
2003/03/12	14:29:40	0.000	0.02
2003/03/12	14:29:45	0.000	-0.01
2003/03/12	14:29:50	0.000	0.01
2003/03/12	14:29:55	0.000	0.00
2003/03/12	14:30:00	0.000	0.00
2003/03/12	14:30:05	0.000	0.01
2003/03/12	14:30:10	0.000	0.03

0.01

2003/03/12 14:29:05

0.01

2003/03/12 14:29:05

0.01

2003/03/12 14:30:05

2003/03/12	14:30:16	0.000	0.02
2003/03/12	14:30:20	0.000	-0.02
2003/03/12	14:30:25	0.000	0.03
2003/03/12	14:30:30	0.000	0.00
2003/03/12	14:30:35	0.000	-0.01
2003/03/12	14:30:40	0.000	0.02
2003/03/12	14:30:45	0.000	-0.01
2003/03/12	14:30:50	0.000	0.01
2003/03/12	14:30:55	0.000	-0.01
2003/03/12	14:31:00	0.000	0.01
2003/03/12	14:31:05	0.000	0.01
2003/03/12	14:31:10	0.000	-0.01
2003/03/12	14:31:15	0.000	0.01
2003/03/12	14:31:20	0.000	0.02
2003/03/12	14:31:25	0.000	0.01
2003/03/12	14:31:30	0.000	-0.01
2003/03/12	14:31:35	0.000	0.03
2003/03/12	14:31:40	0.000	0.02
2003/03/12	14:31:45	0.000	-0.01
2003/03/12	14:31:50	0.000	0.03
2003/03/12	14:31:55	0.000	-0.02
2003/03/12	14:32:00	0.000	0.00
2003/03/12	14:32:05	0.000	0.00
2003/03/12	14:32:10	0.000	0.00
2003/03/12	14:32:15	0.000	0.01
2003/03/12	14:32:20	0.000	-0.01
2003/03/12	14:32:25	0.000	0.02
2003/03/12	14:32:30	0.000	0.00
2003/03/12	14:32:35	0.000	0.01
2003/03/12	14:32:40	0.000	0.01
2003/03/12	14:32:45	0.000	0.03
2003/03/12	14:32:50	0.000	0.02
2003/03/12	14:32:55	0.000	-0.02
2003/03/12	14:33:00	0.000	0.03
2003/03/12	14:33:05	0.000	-0.01
2003/03/12	14:33:10	0.000	0.00
2003/03/12	14:33:15	0.000	0.02
2003/03/12	14:33:20	0.000	-0.01
2003/03/12	14:33:25	0.000	0.00
2003/03/12	14:33:30	0.000	-0.02
2003/03/12	14:33:35	0.000	0.01
2003/03/12	14:33:40	0.000	0.01
2003/03/12	14:33:45	0.000	-0.01
2003/03/12	14:33:50	0.000	0.02
2003/03/12	14:33:55	0.000	0.02
2003/03/12	14:34:00	0.000	0.01
2003/03/12	14:34:05	0.000	-0.01
2003/03/12	14:34:10	0.000	0.03
2003/03/12	14:34:15	0.000	0.01
2003/03/12	14:34:20	0.000	-0.01
2003/03/12	14:34:25	0.000	0.03
2003/03/12	14:34:30	0.000	-0.02
2003/03/12	14:34:35	0.000	0.01
2003/03/12	14:34:40	0.000	0.00
2003/03/12	14:34:45	0.000	0.00
2003/03/12	14:34:50	0.000	0.01
2003/03/12	14:34:55	0.000	-0.01
2003/03/12	14:35:00	0.000	0.02
2003/03/12	14:35:05	0.000	0.01
2003/03/12	14:35:10	0.000	0.01
2003/03/12	14:35:15	0.000	0.01
2003/03/12	14:35:20	0.000	0.03
2003/03/12	14:35:25	0.000	0.01
2003/03/12	14:35:30	0.000	-0.02
2003/03/12	14:35:35	0.000	0.03
2003/03/12	14:35:40	0.000	-0.01
2003/03/12	14:35:45	0.000	0.00
2003/03/12	14:35:50	0.000	0.01
2003/03/12	14:35:55	0.000	-0.01
2003/03/12	14:36:00	0.000	0.01
2003/03/12	14:36:05	0.000	-0.02
2003/03/12	14:36:10	0.000	0.01
2003/03/12	14:36:15	0.000	0.01
2003/03/12	14:36:20	0.000	0.00
2003/03/12	14:36:25	0.000	0.02
2003/03/12	14:36:30	0.000	0.02
2003/03/12	14:36:35	0.000	0.01
2003/03/12	14:36:40	0.000	-0.01
2003/03/12	14:36:45	0.000	0.03
2003/03/12	14:36:50	0.000	0.01
2003/03/12	14:36:55	0.000	-0.01
2003/03/12	14:37:00	0.000	0.03
2003/03/12	14:37:05	0.000	-0.02
2003/03/12	14:37:10	0.000	0.01
2003/03/12	14:37:15	0.000	-0.01
2003/03/12	14:37:20	0.000	0.01
2003/03/12	14:37:25	0.000	0.02
2003/03/12	14:37:30	0.000	-0.01
2003/03/12	14:37:35	0.000	0.01
2003/03/12	14:37:40	0.000	0.01
2003/03/12	14:37:45	0.000	0.01
2003/03/12	14:37:50	0.000	0.00
2003/03/12	14:37:55	0.000	0.03
2003/03/12	14:38:00	0.000	0.01
2003/03/12	14:38:05	0.000	-0.01
2003/03/12	14:38:10	0.000	0.03
2003/03/12	14:38:15	0.000	-0.01
2003/03/12	14:38:20	0.000	0.00
2003/03/12	14:38:25	0.000	0.01
2003/03/12	14:38:30	0.000	0.01
2003/03/12	14:38:35	0.000	0.01
2003/03/12	14:38:40	0.000	-0.01
2003/03/12	14:38:45	0.000	0.03
2003/03/12	14:38:50	0.000	0.01
2003/03/12	14:38:55	0.000	-0.01
2003/03/12	14:39:00	0.000	0.03
2003/03/12	14:39:05	0.000	0.02
2003/03/12	14:39:10	0.000	0.03
2003/03/12	14:39:15	0.000	-0.02
2003/03/12	14:39:20	0.000	0.03
2003/03/12	14:39:25	0.000	0.00
2003/03/12	14:39:30	0.000	-0.01
2003/03/12	14:39:35	0.000	0.02
2003/03/12	14:39:40	0.000	-0.02
2003/03/12	14:39:45	0.000	0.00
2003/03/12	14:39:50	0.000	-0.01
2003/03/12	14:39:55	0.000	0.01
2003/03/12	14:40:00	0.000	0.02
2003/03/12	14:40:05	0.000	-0.01
2003/03/12	14:40:10	0.000	0.01
2003/03/12	14:40:15	0.000	0.01
2003/03/12	14:40:20	0.000	0.01
2003/03/12	14:40:25	0.000	0.00
2003/03/12	14:40:30	0.000	0.03
2003/03/12	14:40:35	0.000	0.02
2003/03/12	14:40:40	0.000	-0.02
2003/03/12	14:40:45	0.000	0.03
2003/03/12	14:40:50	0.000	-0.01
2003/03/12	14:40:55	0.000	0.01
2003/03/12	14:41:00	0.000	0.01
2003/03/12	14:41:05	0.000	0.00
2003/03/12	14:41:10	0.000	0.01
2003/03/12	14:41:15	0.000	-0.01
2003/03/12	14:41:20	0.000	0.02

0.01

2003/03/12 14:34:00

0.01

2003/03/12 14:40:00

2003/03/12	14:41:25	0.000	0.01
2003/03/12	14:41:30	0.000	0.01
2003/03/12	14:41:35	0.000	0.02
2003/03/12	14:41:40	0.000	0.03
2003/03/12	14:41:45	0.000	0.02
2003/03/12	14:41:50	0.000	-0.01
2003/03/12	14:41:55	0.000	0.04
2003/03/12	14:42:00	0.000	0.02
2003/03/12	14:42:05	0.000	0.00
2003/03/12	14:42:10	0.000	0.04
2003/03/12	14:42:15	0.000	0.00
2003/03/12	14:42:20	0.000	0.02
2003/03/12	14:42:25	0.000	0.01
2003/03/12	14:42:30	0.000	0.03
2003/03/12	14:42:35	0.000	0.03
2003/03/12	14:42:40	0.000	0.01
2003/03/12	14:42:45	0.000	0.04
2003/03/12	14:42:50	0.000	0.04
2003/03/12	14:42:55	0.000	0.03
2003/03/12	14:43:00	0.000	0.02
2003/03/12	14:43:05	0.000	0.04
2003/03/12	14:43:10	0.000	0.02
2003/03/12	14:43:15	0.000	-0.02
2003/03/12	14:43:20	0.000	0.03
2003/03/12	14:43:25	0.000	-0.01
2003/03/12	14:43:30	0.000	0.01
2003/03/12	14:43:35	0.000	0.00
2003/03/12	14:43:40	0.000	-0.01
2003/03/12	14:43:45	0.000	0.00
2003/03/12	14:43:50	0.000	-0.02
2003/03/12	14:43:55	0.000	0.01
2003/03/12	14:44:00	0.000	0.00
2003/03/12	14:44:05	0.000	0.00
2003/03/12	14:44:10	0.000	0.03
2003/03/12	14:44:15	0.000	0.05
2003/03/12	14:44:20	0.000	0.03
2003/03/12	14:44:25	0.000	0.01
2003/03/12	14:44:30	0.000	0.06
2003/03/12	14:44:35	0.000	0.02
2003/03/12	14:44:40	0.000	0.01
2003/03/12	14:44:45	0.000	0.03
2003/03/12	14:44:50	0.000	-0.01
2003/03/12	14:44:55	0.000	0.01
2003/03/12	14:45:00	0.000	-0.01
2003/03/12	14:45:05	0.000	0.01
2003/03/12	14:45:10	0.000	0.01
2003/03/12	14:45:15	0.000	-0.01
2003/03/12	14:45:20	0.000	0.02
2003/03/12	14:45:25	0.000	0.02
2003/03/12	14:45:30	0.000	0.01
2003/03/12	14:45:35	0.000	0.00
2003/03/12	14:45:40	0.000	0.03
2003/03/12	14:45:45	0.000	0.01
2003/03/12	14:45:50	0.000	-0.01
2003/03/12	14:45:55	0.000	0.03
2003/03/12	14:46:00	0.000	-0.02
2003/03/12	14:46:05	0.000	0.00
2003/03/12	14:46:10	0.000	0.00
2003/03/12	14:46:15	0.000	0.00
2003/03/12	14:46:20	0.000	0.02
2003/03/12	14:46:25	0.000	-0.02
2003/03/12	14:46:30	0.000	0.01
2003/03/12	14:46:35	0.000	0.00
2003/03/12	14:46:40	0.000	0.03
2003/03/12	14:46:45	0.000	0.01
2003/03/12	14:46:50	0.000	0.00
2003/03/12	14:46:55	0.000	0.03
2003/03/12	14:47:00	0.000	-0.02
2003/03/12	14:47:05	0.000	0.03
2003/03/12	14:47:10	0.000	-0.01
2003/03/12	14:47:15	0.000	-0.01
2003/03/12	14:47:20	0.000	0.02
2003/03/12	14:47:25	0.000	-0.01
2003/03/12	14:47:30	0.000	0.01
2003/03/12	14:47:35	0.000	-0.01
2003/03/12	14:47:40	0.000	0.01
2003/03/12	14:47:45	0.000	0.01
2003/03/12	14:47:50	0.000	-0.01
2003/03/12	14:47:55	0.000	0.01
2003/03/12	14:48:00	0.000	0.02
2003/03/12	14:48:05	0.000	0.01
2003/03/12	14:48:10	0.000	-0.01
2003/03/12	14:48:15	0.000	0.03
2003/03/12	14:48:20	0.000	0.01
2003/03/12	14:48:25	0.000	-0.01
2003/03/12	14:48:30	0.000	0.03
2003/03/12	14:48:35	0.000	-0.02
2003/03/12	14:48:40	0.000	0.00
2003/03/12	14:48:45	0.000	0.00
2003/03/12	14:48:50	0.000	0.02
2003/03/12	14:48:55	0.000	-0.01
2003/03/12	14:49:00	0.000	0.01
2003/03/12	14:49:05	0.000	0.01
2003/03/12	14:49:10	0.000	0.01
2003/03/12	14:49:15	0.000	0.01
2003/03/12	14:49:20	0.000	0.03
2003/03/12	14:49:25	0.000	0.01
2003/03/12	14:49:30	0.000	0.01
2003/03/12	14:49:35	0.000	0.03
2003/03/12	14:49:40	0.000	0.03
2003/03/12	14:49:45	0.000	-0.01
2003/03/12	14:49:50	0.000	0.00
2003/03/12	14:49:55	0.000	0.02
2003/03/12	14:50:00	0.000	-0.01
2003/03/12	14:50:05	0.000	0.01
2003/03/12	14:50:10	0.000	-0.01
2003/03/12	14:50:15	0.000	0.01
2003/03/12	14:50:20	0.000	0.01
2003/03/12	14:50:25	0.000	-0.01
2003/03/12	14:50:30	0.000	0.01
2003/03/12	14:50:35	0.000	0.02
2003/03/12	14:50:40	0.000	0.01
2003/03/12	14:50:45	0.000	-0.01
2003/03/12	14:50:50	0.000	0.03
2003/03/12	14:50:55	0.000	0.02
2003/03/12	14:51:00	0.000	-0.01
2003/03/12	14:51:05	0.000	0.03
2003/03/12	14:51:10	0.000	-0.02
2003/03/12	14:51:15	0.000	0.00
2003/03/12	14:51:20	0.000	0.00
2003/03/12	14:51:25	0.000	0.00
2003/03/12	14:51:30	0.000	0.01
2003/03/12	14:51:35	0.000	-0.01
2003/03/12	14:51:40	0.000	0.02
2003/03/12	14:51:45	0.000	0.00
2003/03/12	14:51:50	0.000	0.01
2003/03/12	14:51:55	0.000	0.01
2003/03/12	14:52:00	0.000	0.03
2003/03/12	14:52:05	0.000	0.02
2003/03/12	14:52:10	0.000	-0.02
2003/03/12	14:52:15	0.000	0.03
2003/03/12	14:52:20	0.000	-0.01
2003/03/12	14:52:25	0.000	0.00
2003/03/12	14:52:30	0.000	0.01

0.01

2003/03/12 14:45:00

0.01

2003/03/12 14:50:00

2003/03/12	14:52:38	0.000	-0.01
2003/03/12	14:52:40	0.000	0.00
2003/03/12	14:52:45	0.000	-0.02
2003/03/12	14:52:50	0.000	0.01
2003/03/12	14:52:55	0.000	0.01
2003/03/12	14:53:00	0.000	0.00
2003/03/12	14:53:05	0.000	0.02
2003/03/12	14:53:10	0.000	0.02
2003/03/12	14:53:15	0.000	0.01
2003/03/12	14:53:20	0.000	-0.01
2003/03/12	14:53:25	0.000	0.03
2003/03/12	14:53:30	0.000	0.01
2003/03/12	14:53:35	0.000	-0.01
2003/03/12	14:53:40	0.000	0.03
2003/03/12	14:53:45	0.000	-0.01
2003/03/12	14:53:50	0.000	0.01
2003/03/12	14:53:55	0.000	0.00
2003/03/12	14:54:00	0.000	0.00
2003/03/12	14:54:05	0.000	0.01
2003/03/12	14:54:10	0.000	-0.01
2003/03/12	14:54:15	0.000	0.02
2003/03/12	14:54:20	0.000	0.01
2003/03/12	14:54:25	0.000	0.01
2003/03/12	14:54:30	0.000	0.01
2003/03/12	14:54:35	0.000	0.03
2003/03/12	14:54:40	0.000	0.01
2003/03/12	14:54:45	0.000	-0.02
2003/03/12	14:54:50	0.000	0.03
2003/03/12	14:54:55	0.000	-0.01
2003/03/12	14:55:00	0.000	0.00
2003/03/12	14:55:05	0.000	0.01
2003/03/12	14:55:10	0.000	-0.01
2003/03/12	14:55:15	0.000	0.01
2003/03/12	14:55:20	0.000	-0.02
2003/03/12	14:55:25	0.000	0.01
2003/03/12	14:55:30	0.000	0.01
2003/03/12	14:55:35	0.000	0.00
2003/03/12	14:55:40	0.000	0.02
2003/03/12	14:55:45	0.000	0.03
2003/03/12	14:55:50	0.000	0.01
2003/03/12	14:55:55	0.000	-0.01
2003/03/12	14:56:00	0.000	0.03
2003/03/12	14:56:05	0.000	0.01
2003/03/12	14:56:10	0.000	-0.01
2003/03/12	14:56:15	0.000	0.01
2003/03/12	14:56:20	0.000	-0.02
2003/03/12	14:56:25	0.000	0.01
2003/03/12	14:56:30	0.000	0.01
2003/03/12	14:56:35	0.000	0.00
2003/03/12	14:56:40	0.000	0.02
2003/03/12	14:56:45	0.000	-0.01
2003/03/12	14:56:50	0.000	0.01
2003/03/12	14:56:55	0.000	0.01
2003/03/12	14:57:00	0.000	0.01
2003/03/12	14:57:05	0.000	0.00
2003/03/12	14:57:10	0.000	0.03
2003/03/12	14:57:15	0.000	0.01
2003/03/12	14:57:20	0.000	-0.01
2003/03/12	14:57:25	0.000	0.03
2003/03/12	14:57:30	0.000	-0.01
2003/03/12	14:57:35	0.000	0.00
2003/03/12	14:57:40	0.000	0.01
2003/03/12	14:57:45	0.000	-0.01
2003/03/12	14:57:50	0.000	0.01
2003/03/12	14:57:55	0.000	-0.02
2003/03/12	14:58:00	0.000	0.01
2003/03/12	14:58:05	0.000	0.01
2003/03/12	14:58:10	0.000	0.00
2003/03/12	14:58:15	0.000	0.02
2003/03/12	14:58:20	0.000	0.03
2003/03/12	14:58:25	0.000	0.01
2003/03/12	14:58:30	0.000	-0.01
2003/03/12	14:58:35	0.000	0.03
2003/03/12	14:58:40	0.000	0.00
2003/03/12	14:58:45	0.000	-0.01
2003/03/12	14:58:50	0.000	0.02
2003/03/12	14:58:55	0.000	-0.01
2003/03/12	14:59:00	0.000	0.01
2003/03/12	14:59:05	0.000	-0.01
2003/03/12	14:59:10	0.000	0.01
2003/03/12	14:59:15	0.000	0.02
2003/03/12	14:59:20	0.000	-0.01
2003/03/12	14:59:25	0.000	0.01
2003/03/12	14:59:30	0.000	0.01
2003/03/12	14:59:35	0.000	0.01
2003/03/12	14:59:40	0.000	0.00
2003/03/12	14:59:45	0.000	0.03
2003/03/12	14:59:50	0.000	0.02
2003/03/12	14:59:55	0.000	-0.02
2003/03/12	15:00:00	0.000	0.03
2003/03/12	15:00:05	0.000	-0.01
2003/03/12	15:00:10	0.000	0.00
2003/03/12	15:00:15	0.000	0.01
2003/03/12	15:00:20	0.000	-0.01
2003/03/12	15:00:25	0.000	0.01
2003/03/12	15:00:30	0.000	-0.01
2003/03/12	15:00:35	0.000	0.01
2003/03/12	15:00:40	0.000	0.01
2003/03/12	15:00:45	0.000	0.00
2003/03/12	15:00:50	0.000	0.01
2003/03/12	15:00:55	0.000	0.02
2003/03/12	15:01:00	0.000	0.02
2003/03/12	15:01:05	0.000	-0.01
2003/03/12	15:01:10	0.000	0.03
2003/03/12	15:01:15	0.000	0.00
2003/03/12	15:01:20	0.000	-0.01
2003/03/12	15:01:25	0.000	0.02
2003/03/12	15:01:30	0.000	-0.01
2003/03/12	15:01:35	0.000	0.00
2003/03/12	15:01:40	0.000	-0.01
2003/03/12	15:01:45	0.000	0.01
2003/03/12	15:01:50	0.000	0.01
2003/03/12	15:01:55	0.000	-0.01
2003/03/12	15:02:00	0.000	0.02
2003/03/12	15:02:05	0.000	0.02
2003/03/12	15:02:10	0.000	0.01
2003/03/12	15:02:15	0.000	0.00
2003/03/12	15:02:20	0.000	0.03
2003/03/12	15:02:25	0.000	0.02
2003/03/12	15:02:30	0.000	-0.01
2003/03/12	15:02:35	0.000	0.03
2003/03/12	15:02:40	0.000	-0.01
2003/03/12	15:02:45	0.000	0.01
2003/03/12	15:02:50	0.000	0.00
2003/03/12	15:02:55	0.000	0.00
2003/03/12	15:03:00	0.000	0.01
2003/03/12	15:03:05	0.000	-0.01
2003/03/12	15:03:10	0.000	0.01
2003/03/12	15:03:15	0.000	0.00
2003/03/12	15:03:20	0.000	0.00
2003/03/12	15:03:25	0.000	0.02
2003/03/12	15:03:30	0.000	0.03
2003/03/12	15:03:35	0.000	0.01
2003/03/12	15:03:40	0.000	-0.02

0.01

0.01

0.01

0.01

2003/03/12	18:03:45	0.000	0.03
2003/03/12	15:03:50	0.000	0.00
2003/03/12	15:03:55	0.000	-0.01
2003/03/12	15:04:00	0.000	0.02
2003/03/12	15:04:05	0.000	-0.01
2003/03/12	15:04:10	0.000	0.01
2003/03/12	15:04:15	0.000	-0.01
2003/03/12	15:04:20	0.000	0.01
2003/03/12	15:04:25	0.000	0.01
2003/03/12	15:04:30	0.000	-0.01
2003/03/12	15:04:35	0.000	0.02
2003/03/12	15:04:40	0.000	0.02
2003/03/12	15:04:45	0.000	0.01
2003/03/12	15:04:50	0.000	-0.01
2003/03/12	15:04:55	0.000	0.03
2003/03/12	15:05:00	0.000	0.01
2003/03/12	15:05:05	0.000	-0.01
2003/03/12	15:05:10	0.000	0.03
2003/03/12	15:05:15	0.000	-0.02
2003/03/12	15:05:20	0.000	0.01
2003/03/12	15:05:25	0.000	0.00
2003/03/12	15:05:30	0.000	0.00
2003/03/12	15:05:35	0.000	0.02
2003/03/12	15:05:40	0.000	-0.01
2003/03/12	15:05:45	0.000	0.01
2003/03/12	15:05:50	0.000	0.01
2003/03/12	15:05:55	0.000	0.01
2003/03/12	15:06:00	0.000	0.01
2003/03/12	15:06:05	0.000	0.03
2003/03/12	15:06:10	0.000	0.01
2003/03/12	15:06:15	0.000	-0.02
2003/03/12	15:06:20	0.000	0.03
2003/03/12	15:06:25	0.000	-0.01
2003/03/12	15:06:30	0.000	0.00
2003/03/12	15:06:35	0.000	0.02
2003/03/12	15:06:40	0.000	-0.01
2003/03/12	15:06:45	0.000	0.01
2003/03/12	15:06:50	0.000	-0.01
2003/03/12	15:06:55	0.000	0.01
2003/03/12	15:07:00	0.000	0.01
2003/03/12	15:07:05	0.000	-0.01
2003/03/12	15:07:10	0.000	0.02
2003/03/12	15:07:15	0.000	0.02
2003/03/12	15:07:20	0.000	0.01
2003/03/12	15:07:25	0.000	-0.01
2003/03/12	15:07:30	0.000	0.03
2003/03/12	15:07:35	0.000	0.01
2003/03/12	15:07:40	0.000	-0.01
2003/03/12	15:07:45	0.000	0.03
2003/03/12	15:07:50	0.000	-0.02
2003/03/12	15:07:55	0.000	0.00
2003/03/12	15:08:00	0.000	0.00
2003/03/12	15:08:05	0.000	0.00
2003/03/12	15:08:10	0.000	0.02
2003/03/12	15:08:15	0.000	-0.01
2003/03/12	15:08:20	0.000	0.01
2003/03/12	15:08:25	0.000	0.01
2003/03/12	15:08:30	0.000	0.01
2003/03/12	15:08:35	0.000	0.01
2003/03/12	15:08:40	0.000	0.03
2003/03/12	15:08:45	0.000	0.02
2003/03/12	15:08:50	0.000	-0.02
2003/03/12	15:08:55	0.000	0.00
2003/03/12	15:09:00	0.000	-0.01
2003/03/12	15:09:05	0.000	0.00
2003/03/12	15:09:10	0.000	0.01
2003/03/12	15:09:15	0.000	-0.01
2003/03/12	15:09:20	0.000	0.01
2003/03/12	15:09:25	0.000	-0.01
2003/03/12	15:09:30	0.000	0.01
2003/03/12	15:09:35	0.000	0.01
2003/03/12	15:09:40	0.000	0.00
2003/03/12	15:09:45	0.000	0.01
2003/03/12	15:09:50	0.000	0.03
2003/03/12	15:09:55	0.000	0.01
2003/03/12	15:10:00	0.000	-0.01
2003/03/12	15:10:05	0.000	0.03
2003/03/12	15:10:10	0.000	0.01
2003/03/12	15:10:15	0.000	-0.01
2003/03/12	15:10:20	0.000	0.02
2003/03/12	15:10:25	0.000	-0.01
2003/03/12	15:10:30	0.000	0.00
2003/03/12	15:10:35	0.000	-0.01
2003/03/12	15:10:40	0.000	0.00
2003/03/12	15:10:45	0.000	0.01
2003/03/12	15:10:50	0.000	-0.01
2003/03/12	15:10:55	0.000	0.02
2003/03/12	15:11:00	0.000	0.01
2003/03/12	15:11:05	0.000	0.01
2003/03/12	15:11:10	0.000	0.00
2003/03/12	15:11:15	0.000	0.03
2003/03/12	15:11:20	0.000	0.02
2003/03/12	15:11:25	0.000	-0.02
2003/03/12	15:11:30	0.000	0.03
2003/03/12	15:11:35	0.000	-0.01
2003/03/12	15:11:40	0.000	0.00
2003/03/12	15:11:45	0.000	0.01
2003/03/12	15:11:50	0.000	-0.01
2003/03/12	15:11:55	0.000	0.00
2003/03/12	15:12:00	0.000	-0.02
2003/03/12	15:12:05	0.000	0.01
2003/03/12	15:12:10	0.000	0.01
2003/03/12	15:12:15	0.000	0.00
2003/03/12	15:12:20	0.000	0.02
2003/03/12	15:12:25	0.000	0.03
2003/03/12	15:12:30	0.000	0.01
2003/03/12	15:12:35	0.000	-0.01
2003/03/12	15:12:40	0.000	0.03
2003/03/12	15:12:45	0.000	0.00
2003/03/12	15:12:50	0.000	-0.01
2003/03/12	15:12:55	0.000	0.02
2003/03/12	15:13:00	0.000	-0.01
2003/03/12	15:13:05	0.000	0.01
2003/03/12	15:13:10	0.000	-0.01
2003/03/12	15:13:15	0.000	0.01
2003/03/12	15:13:20	0.000	0.01
2003/03/12	15:13:25	0.000	-0.01
2003/03/12	15:13:30	0.000	0.02
2003/03/12	15:13:35	0.000	0.01
2003/03/12	15:13:40	0.000	0.01
2003/03/12	15:13:45	0.000	0.00
2003/03/12	15:13:50	0.000	0.03
2003/03/12	15:13:55	0.000	0.01
2003/03/12	15:14:00	0.000	-0.01
2003/03/12	15:14:05	0.000	0.03
2003/03/12	15:14:10	0.000	-0.02
2003/03/12	15:14:15	0.000	0.00
2003/03/12	15:14:20	0.000	0.01
2003/03/12	15:14:25	0.000	0.00
2003/03/12	15:14:30	0.000	0.02
2003/03/12	15:14:35	0.000	-0.02
2003/03/12	15:14:40	0.000	0.01
2003/03/12	15:14:45	0.000	0.00
2003/03/12	15:14:50	0.000	0.00

0.01

2003/03/12 15:03:45

0.01

2003/03/12 15:03:45

2003/03/12	16:14:58	0.000	0.02
2003/03/12	16:15:00	0.000	0.03
2003/03/12	16:15:06	0.000	0.01
2003/03/12	16:15:10	0.000	-0.01
2003/03/12	16:15:15	0.000	0.03
2003/03/12	16:15:20	0.000	0.00
2003/03/12	16:15:28	0.000	-0.01
2003/03/12	16:15:30	0.000	0.02
2003/03/12	16:15:35	0.000	-0.01
2003/03/12	16:15:40	0.000	0.01
2003/03/12	16:15:45	0.000	-0.01
2003/03/12	16:15:50	0.000	0.01
2003/03/12	16:15:55	0.000	0.01
2003/03/12	16:16:00	0.000	-0.01
2003/03/12	16:16:05	0.000	0.01
2003/03/12	16:16:10	0.000	0.02
2003/03/12	16:16:15	0.000	0.01
2003/03/12	16:16:20	0.000	-0.01
2003/03/12	16:16:25	0.000	0.03
2003/03/12	16:16:30	0.000	0.01
2003/03/12	16:16:35	0.000	-0.01
2003/03/12	16:16:40	0.000	0.03
2003/03/12	16:16:45	0.000	-0.02
2003/03/12	16:16:50	0.000	0.00
2003/03/12	16:16:55	0.000	0.00
2003/03/12	16:17:00	0.000	0.00
2003/03/12	16:17:05	0.000	0.02
2003/03/12	16:17:10	0.000	-0.01
2003/03/12	16:17:15	0.000	0.01
2003/03/12	16:17:20	0.000	0.01
2003/03/12	16:17:25	0.000	0.01
2003/03/12	16:17:30	0.000	0.02
2003/03/12	16:17:35	0.000	0.03
2003/03/12	16:17:40	0.000	0.02
2003/03/12	16:17:45	0.000	-0.01
2003/03/12	16:17:50	0.000	0.04
2003/03/12	16:17:55	0.000	0.01
2003/03/12	16:18:00	0.000	0.01
2003/03/12	16:18:05	0.000	0.03
2003/03/12	16:18:10	0.000	0.01
2003/03/12	16:18:15	0.000	0.03
2003/03/12	16:18:20	0.000	0.01
2003/03/12	16:18:25	0.000	0.04
2003/03/12	16:18:30	0.000	0.03
2003/03/12	16:18:35	0.000	0.02
2003/03/12	16:18:40	0.000	0.03
2003/03/12	16:18:45	0.000	0.05
2003/03/12	16:18:50	0.000	0.04
2003/03/12	16:18:55	0.000	0.02
2003/03/12	16:19:00	0.000	0.05
2003/03/12	16:19:05	0.000	0.05
2003/03/12	16:19:10	0.000	0.02
2003/03/12	16:19:15	0.000	0.05
2003/03/12	16:19:20	0.000	0.01
2003/03/12	16:19:25	0.000	0.03
2003/03/12	16:19:30	0.000	0.02
2003/03/12	16:19:35	0.000	0.01
2003/03/12	16:19:40	0.000	0.02
2003/03/12	16:19:45	0.000	-0.01
2003/03/12	16:19:50	0.000	0.02
2003/03/12	16:19:55	0.000	0.00
2003/03/12	16:20:00	0.000	0.01
2003/03/12	16:20:05	0.000	0.01
2003/03/12	16:20:10	0.000	0.03
2003/03/12	16:20:15	0.000	0.02
2003/03/12	16:20:20	0.000	-0.02
2003/03/12	16:20:25	0.000	0.03
2003/03/12	16:20:30	0.000	-0.01
2003/03/12	16:20:35	0.000	0.02
2003/03/12	16:20:40	0.000	0.04
2003/03/12	16:20:45	0.000	0.03
2003/03/12	16:20:50	0.000	0.04
2003/03/12	16:20:55	0.000	0.02
2003/03/12	16:21:00	0.000	0.05
2003/03/12	16:21:05	0.000	0.05
2003/03/12	16:21:10	0.000	0.03
2003/03/12	16:21:15	0.000	0.05
2003/03/12	16:21:20	0.000	0.04
2003/03/12	16:21:25	0.000	0.01
2003/03/12	16:21:30	0.000	-0.01
2003/03/12	16:21:35	0.000	0.03
2003/03/12	16:21:40	0.000	0.01
2003/03/12	16:21:45	0.000	-0.01
2003/03/12	16:21:50	0.000	0.03
2003/03/12	16:21:55	0.000	-0.01
2003/03/12	16:22:00	0.000	0.01
2003/03/12	16:22:05	0.000	-0.01
2003/03/12	16:22:10	0.000	0.00
2003/03/12	16:22:15	0.000	0.01
2003/03/12	16:22:20	0.000	-0.01
2003/03/12	16:22:25	0.000	0.02
2003/03/12	16:22:30	0.000	0.01
2003/03/12	16:22:35	0.000	0.01
2003/03/12	16:22:40	0.000	0.01
2003/03/12	16:22:45	0.000	0.03
2003/03/12	16:22:50	0.000	0.01
2003/03/12	16:22:55	0.000	-0.02
2003/03/12	16:23:00	0.000	0.03
2003/03/12	16:23:05	0.000	-0.01
2003/03/12	16:23:10	0.000	0.00
2003/03/12	16:23:15	0.000	0.01
2003/03/12	16:23:20	0.000	-0.01
2003/03/12	16:23:25	0.000	0.01
2003/03/12	16:23:30	0.000	-0.02
2003/03/12	16:23:35	0.000	0.01
2003/03/12	16:23:40	0.000	0.01
2003/03/12	16:23:45	0.000	0.00
2003/03/12	16:23:50	0.000	0.02
2003/03/12	16:23:55	0.000	0.03
2003/03/12	16:24:00	0.000	0.01
2003/03/12	16:24:05	0.000	-0.01
2003/03/12	16:24:10	0.000	0.03
2003/03/12	16:24:15	0.000	0.00
2003/03/12	16:24:20	0.000	-0.01
2003/03/12	16:24:25	0.000	0.02
2003/03/12	16:24:30	0.000	-0.01
2003/03/12	16:24:35	0.000	0.01
2003/03/12	16:24:40	0.000	-0.01
2003/03/12	16:24:45	0.000	0.01
2003/03/12	16:24:50	0.000	0.02
2003/03/12	16:24:55	0.000	-0.01
2003/03/12	16:25:00	0.000	0.01
2003/03/12	16:25:05	0.000	0.01
2003/03/12	16:25:10	0.000	0.01
2003/03/12	16:25:15	0.000	0.00
2003/03/12	16:25:20	0.000	0.03
2003/03/12	16:25:25	0.000	0.01
2003/03/12	16:25:30	0.000	-0.01
2003/03/12	16:25:35	0.000	0.03
2003/03/12	16:25:40	0.000	-0.02
2003/03/12	16:25:45	0.000	0.00
2003/03/12	16:25:50	0.000	0.01
2003/03/12	16:25:55	0.000	-0.01
2003/03/12	16:26:00	0.000	0.02

0.01

SP20030312161458

0.02

SP20030312162000

0.01

SP20030312162500

2003/03/12	15:28:05	0.000	-0.02
2003/03/12	15:28:10	0.000	0.01
2003/03/12	15:28:15	0.000	0.01
2003/03/12	15:28:20	0.000	0.00
2003/03/12	15:28:25	0.000	0.02
2003/03/12	15:28:30	0.000	0.03
2003/03/12	15:28:35	0.000	0.02
2003/03/12	15:28:40	0.000	-0.02
2003/03/12	15:28:45	0.000	0.03
2003/03/12	15:28:50	0.000	0.00
2003/03/12	15:28:55	0.000	-0.01
2003/03/12	15:27:00	0.000	0.02
2003/03/12	15:27:05	0.000	-0.01
2003/03/12	15:27:10	0.000	0.01
2003/03/12	15:27:15	0.000	-0.01
2003/03/12	15:27:20	0.000	0.01
2003/03/12	15:27:25	0.000	0.01
2003/03/12	15:27:30	0.000	-0.01
2003/03/12	15:27:35	0.000	0.01
2003/03/12	15:27:40	0.000	0.01
2003/03/12	15:27:45	0.000	0.01
2003/03/12	15:27:50	0.000	-0.01
2003/03/12	15:27:55	0.000	0.03
2003/03/12	15:28:00	0.000	0.02
2003/03/12	15:28:05	0.000	-0.02
2003/03/12	15:28:10	0.000	0.03
2003/03/12	15:28:15	0.000	-0.02
2003/03/12	15:28:20	0.000	0.00
2003/03/12	15:28:25	0.000	0.00
2003/03/12	15:28:30	0.000	0.00
2003/03/12	15:28:35	0.000	0.01
2003/03/12	15:28:40	0.000	-0.01
2003/03/12	15:28:45	0.000	0.02
2003/03/12	15:28:50	0.000	0.00
2003/03/12	15:28:55	0.000	0.00
2003/03/12	15:29:00	0.000	0.01
2003/03/12	15:29:05	0.000	0.03
2003/03/12	15:29:10	0.000	0.02
2003/03/12	15:29:15	0.000	0.03
2003/03/12	15:29:20	0.000	-0.02
2003/03/12	15:29:25	0.000	0.00
2003/03/12	15:29:30	0.000	0.00
2003/03/12	15:29:35	0.000	0.02
2003/03/12	15:29:40	0.000	-0.01
2003/03/12	15:29:45	0.000	0.00
2003/03/12	15:29:50	0.000	-0.01
2003/03/12	15:29:55	0.000	0.01
2003/03/12	15:30:00	0.000	0.01
2003/03/12	15:30:05	0.000	-0.01
2003/03/12	15:30:10	0.000	0.02
2003/03/12	15:30:15	0.000	0.02
2003/03/12	15:30:20	0.000	0.01
2003/03/12	15:30:25	0.000	-0.01
2003/03/12	15:30:30	0.000	0.03
2003/03/12	15:30:35	0.000	0.02
2003/03/12	15:30:40	0.000	-0.01
2003/03/12	15:30:45	0.000	0.03
2003/03/12	15:30:50	0.000	-0.02
2003/03/12	15:30:55	0.000	0.01
2003/03/12	15:31:00	0.000	0.00
2003/03/12	15:31:05	0.000	0.00
2003/03/12	15:31:10	0.000	0.01
2003/03/12	15:31:15	0.000	-0.01
2003/03/12	15:31:20	0.000	0.02
2003/03/12	15:31:25	0.000	0.00
2003/03/12	15:31:30	0.000	0.01
2003/03/12	15:31:35	0.000	0.01
2003/03/12	15:31:40	0.000	0.03
2003/03/12	15:31:45	0.000	0.01
2003/03/12	15:31:50	0.000	-0.02
2003/03/12	15:31:55	0.000	0.03
2003/03/12	15:32:00	0.000	-0.01
2003/03/12	15:32:05	0.000	0.00
2003/03/12	15:32:10	0.000	0.01
2003/03/12	15:32:15	0.000	-0.01
2003/03/12	15:32:20	0.000	0.01
2003/03/12	15:32:25	0.000	-0.02
2003/03/12	15:32:30	0.000	0.01
2003/03/12	15:32:35	0.000	0.01
2003/03/12	15:32:40	0.000	0.00
2003/03/12	15:32:45	0.000	0.02
2003/03/12	15:32:50	0.000	0.02
2003/03/12	15:32:55	0.000	0.01
2003/03/12	15:33:00	0.000	-0.01
2003/03/12	15:33:05	0.000	0.03
2003/03/12	15:33:10	0.000	0.01
2003/03/12	15:33:15	0.000	-0.01
2003/03/12	15:33:20	0.000	0.03
2003/03/12	15:33:25	0.000	-0.02
2003/03/12	15:33:30	0.000	0.01
2003/03/12	15:33:35	0.000	-0.01
2003/03/12	15:33:40	0.000	0.00
2003/03/12	15:33:45	0.000	0.02
2003/03/12	15:33:50	0.000	-0.01
2003/03/12	15:33:55	0.000	0.01
2003/03/12	15:34:00	0.000	0.01
2003/03/12	15:34:05	0.000	0.01
2003/03/12	15:34:10	0.000	0.00
2003/03/12	15:34:15	0.000	0.03
2003/03/12	15:34:20	0.000	0.01
2003/03/12	15:34:25	0.000	-0.01
2003/03/12	15:34:30	0.000	0.03
2003/03/12	15:34:35	0.000	-0.01
2003/03/12	15:34:40	0.000	0.00
2003/03/12	15:34:45	0.000	0.01
2003/03/12	15:34:50	0.000	-0.01
2003/03/12	15:34:55	0.000	0.01
2003/03/12	15:35:00	0.000	-0.02
2003/03/12	15:35:05	0.000	0.01
2003/03/12	15:35:10	0.000	0.01
2003/03/12	15:35:15	0.000	0.00
2003/03/12	15:35:20	0.000	0.02
2003/03/12	15:35:25	0.000	0.03
2003/03/12	15:35:30	0.000	0.02
2003/03/12	15:35:35	0.000	-0.02
2003/03/12	15:35:40	0.000	0.03
2003/03/12	15:35:45	0.000	0.00
2003/03/12	15:35:50	0.000	-0.01
2003/03/12	15:35:55	0.000	0.02
2003/03/12	15:36:00	0.000	-0.01
2003/03/12	15:36:05	0.000	0.00
2003/03/12	15:36:10	0.000	-0.01
2003/03/12	15:36:15	0.000	0.01
2003/03/12	15:36:20	0.000	0.02
2003/03/12	15:36:25	0.000	-0.01
2003/03/12	15:36:30	0.000	0.01
2003/03/12	15:36:35	0.000	0.02
2003/03/12	15:36:40	0.000	0.01
2003/03/12	15:36:45	0.000	0.00
2003/03/12	15:36:50	0.000	0.03
2003/03/12	15:36:55	0.000	0.03
2003/03/12	15:37:00	0.000	-0.01
2003/03/12	15:37:05	0.000	0.04
2003/03/12	15:37:10	0.000	0.00

0.01

2003/03/12/15:30:05

0.01

2003/03/12/15:35:05

2003/03/12	15:37:15	0.000	0.02
2003/03/12	15:37:20	0.000	0.02
2003/03/12	15:37:25	0.000	0.01
2003/03/12	15:37:30	0.000	0.03
2003/03/12	15:37:35	0.000	0.00
2003/03/12	15:37:40	0.000	0.03
2003/03/12	15:37:45	0.000	0.02
2003/03/12	15:37:50	0.000	0.02
2003/03/12	15:37:55	0.000	0.03
2003/03/12	15:38:00	0.000	0.04
2003/03/12	15:38:05	0.000	0.03
2003/03/12	15:38:10	0.000	0.00
2003/03/12	15:38:15	0.000	0.05
2003/03/12	15:38:20	0.000	0.02
2003/03/12	15:38:25	0.000	0.01
2003/03/12	15:38:30	0.000	0.04
2003/03/12	15:38:35	0.000	0.00
2003/03/12	15:38:40	0.000	0.01
2003/03/12	15:38:45	0.000	-0.01
2003/03/12	15:38:50	0.000	0.01
2003/03/12	15:38:55	0.000	0.01
2003/03/12	15:39:00	0.000	-0.01
2003/03/12	15:39:05	0.000	0.02
2003/03/12	15:39:10	0.000	0.02
2003/03/12	15:39:15	0.000	0.01
2003/03/12	15:39:20	0.000	-0.01
2003/03/12	15:39:25	0.000	0.03
2003/03/12	15:39:30	0.000	0.02
2003/03/12	15:39:35	0.000	-0.01
2003/03/12	15:39:40	0.000	0.03
2003/03/12	15:39:45	0.000	-0.02
2003/03/12	15:39:50	0.000	0.01
2003/03/12	15:39:55	0.000	0.00
2003/03/12	15:40:00	0.000	0.03
2003/03/12	15:40:05	0.000	0.01
2003/03/12	15:40:10	0.000	-0.01
2003/03/12	15:40:15	0.000	0.02
2003/03/12	15:40:20	0.000	0.00
2003/03/12	15:40:25	0.000	0.01
2003/03/12	15:40:30	0.000	0.01
2003/03/12	15:40:35	0.000	0.03
2003/03/12	15:40:40	0.000	0.01
2003/03/12	15:40:45	0.000	-0.02
2003/03/12	15:40:50	0.000	0.03
2003/03/12	15:40:55	0.000	-0.01
2003/03/12	15:41:00	0.000	0.00
2003/03/12	15:41:05	0.000	0.01
2003/03/12	15:41:10	0.000	-0.01
2003/03/12	15:41:15	0.000	0.01
2003/03/12	15:41:20	0.000	-0.02
2003/03/12	15:41:25	0.000	0.01
2003/03/12	15:41:30	0.000	0.01
2003/03/12	15:41:35	0.000	0.00
2003/03/12	15:41:40	0.000	0.02
2003/03/12	15:41:45	0.000	0.02
2003/03/12	15:41:50	0.000	0.01
2003/03/12	15:41:55	0.000	-0.01
2003/03/12	15:42:00	0.000	0.03
2003/03/12	15:42:05	0.000	0.01
2003/03/12	15:42:10	0.000	-0.01
2003/03/12	15:42:15	0.000	0.03
2003/03/12	15:42:20	0.000	-0.02
2003/03/12	15:42:25	0.000	0.01
2003/03/12	15:42:30	0.000	-0.01
2003/03/12	15:42:35	0.000	0.00
2003/03/12	15:42:40	0.000	0.02
2003/03/12	15:42:45	0.000	-0.01
2003/03/12	15:42:50	0.000	0.01
2003/03/12	15:42:55	0.000	0.01
2003/03/12	15:43:00	0.000	0.01
2003/03/12	15:43:05	0.000	0.00
2003/03/12	15:43:10	0.000	0.03
2003/03/12	15:43:15	0.000	0.01
2003/03/12	15:43:20	0.000	-0.01
2003/03/12	15:43:25	0.000	0.03
2003/03/12	15:43:30	0.000	-0.01
2003/03/12	15:43:35	0.000	0.00
2003/03/12	15:43:40	0.000	0.01
2003/03/12	15:43:45	0.000	-0.01
2003/03/12	15:43:50	0.000	0.02
2003/03/12	15:43:55	0.000	0.01
2003/03/12	15:44:00	0.000	0.01
2003/03/12	15:44:05	0.000	0.01
2003/03/12	15:44:10	0.000	0.00
2003/03/12	15:44:15	0.000	0.02
2003/03/12	15:44:20	0.000	0.02
2003/03/12	15:44:25	0.000	0.02
2003/03/12	15:44:30	0.000	-0.02
2003/03/12	15:44:35	0.000	0.03
2003/03/12	15:44:40	0.000	0.00
2003/03/12	15:44:45	0.000	-0.01
2003/03/12	15:44:50	0.000	0.02
2003/03/12	15:44:55	0.000	-0.01
2003/03/12	15:45:00	0.000	0.01
2003/03/12	15:45:05	0.000	-0.01
2003/03/12	15:45:10	0.000	0.01
2003/03/12	15:45:15	0.000	0.01
2003/03/12	15:45:20	0.000	-0.01
2003/03/12	15:45:25	0.000	0.01
2003/03/12	15:45:30	0.000	0.02
2003/03/12	15:45:35	0.000	0.01
2003/03/12	15:45:40	0.000	-0.01
2003/03/12	15:45:45	0.000	0.03
2003/03/12	15:45:50	0.000	0.02
2003/03/12	15:45:55	0.000	-0.02
2003/03/12	15:46:00	0.000	0.03
2003/03/12	15:46:05	0.000	-0.02
2003/03/12	15:46:10	0.000	0.00
2003/03/12	15:46:15	0.000	0.00
2003/03/12	15:46:20	0.000	0.00
2003/03/12	15:46:25	0.000	0.01
2003/03/12	15:46:30	0.000	-0.01
2003/03/12	15:46:35	0.000	0.02
2003/03/12	15:46:40	0.000	0.00
2003/03/12	15:46:45	0.000	0.00
2003/03/12	15:46:50	0.000	0.01
2003/03/12	15:46:55	0.000	0.03
2003/03/12	15:47:00	0.000	0.02
2003/03/12	15:47:05	0.000	-0.02
2003/03/12	15:47:10	0.000	0.03
2003/03/12	15:47:15	0.000	0.00
2003/03/12	15:47:20	0.000	0.00
2003/03/12	15:47:25	0.000	0.02
2003/03/12	15:47:30	0.000	-0.01
2003/03/12	15:47:35	0.000	0.00
2003/03/12	15:47:40	0.000	-0.02
2003/03/12	15:47:45	0.000	0.01
2003/03/12	15:47:50	0.000	0.01
2003/03/12	15:47:55	0.000	-0.01
2003/03/12	15:48:00	0.000	0.02
2003/03/12	15:48:05	0.000	0.02
2003/03/12	15:48:10	0.000	0.01
2003/03/12	15:48:15	0.000	-0.01
2003/03/12	15:48:20	0.000	0.03

0.01

2003/03/12 15:40:25

0.01

2003/03/12 15:44:55

2003/03/12	15:48:25	0.000	0.01
2003/03/12	15:48:30	0.000	-0.01
2003/03/12	15:48:35	0.000	0.03
2003/03/12	15:48:40	0.000	-0.02
2003/03/12	15:48:45	0.000	0.01
2003/03/12	15:48:50	0.000	-0.01
2003/03/12	15:48:55	0.000	0.00
2003/03/12	15:49:00	0.000	0.01
2003/03/12	15:49:05	0.000	-0.01
2003/03/12	15:49:10	0.000	0.02
2003/03/12	15:49:15	0.000	0.01
2003/03/12	15:49:20	0.000	0.01
2003/03/12	15:49:25	0.000	0.01
2003/03/12	15:49:30	0.000	0.03
2003/03/12	15:49:35	0.000	0.01
2003/03/12	15:49:40	0.000	-0.02
2003/03/12	15:49:45	0.000	0.03
2003/03/12	15:49:50	0.000	-0.01
2003/03/12	15:49:55	0.000	0.00
2003/03/12	15:50:00	0.000	0.01
2003/03/12	15:50:05	0.000	-0.01
2003/03/12	15:50:10	0.000	0.01
2003/03/12	15:50:15	0.000	-0.02
2003/03/12	15:50:20	0.000	0.01
2003/03/12	15:50:25	0.000	0.01
2003/03/12	15:50:30	0.000	0.00
2003/03/12	15:50:35	0.000	0.02
2003/03/12	15:50:40	0.000	0.03
2003/03/12	15:50:45	0.000	0.01
2003/03/12	15:50:50	0.000	-0.01
2003/03/12	15:50:55	0.000	0.03
2003/03/12	15:51:00	0.000	0.00
2003/03/12	15:51:05	0.000	-0.01
2003/03/12	15:51:10	0.000	0.02
2003/03/12	15:51:15	0.000	-0.01
2003/03/12	15:51:20	0.000	0.01
2003/03/12	15:51:25	0.000	-0.01
2003/03/12	15:51:30	0.000	0.01
2003/03/12	15:51:35	0.000	0.02
2003/03/12	15:51:40	0.000	-0.01
2003/03/12	15:51:45	0.000	0.02
2003/03/12	15:51:50	0.000	0.02
2003/03/12	15:51:55	0.000	0.02
2003/03/12	15:52:00	0.000	0.01
2003/03/12	15:52:05	0.000	0.04
2003/03/12	15:52:10	0.000	0.02
2003/03/12	15:52:15	0.000	-0.01
2003/03/12	15:52:20	0.000	0.04
2003/03/12	15:52:25	0.000	-0.01
2003/03/12	15:52:30	0.000	0.02
2003/03/12	15:52:35	0.000	0.02
2003/03/12	15:52:40	0.000	0.01
2003/03/12	15:52:45	0.000	0.04
2003/03/12	15:52:50	0.000	0.00
2003/03/12	15:52:55	0.000	0.03
2003/03/12	15:53:00	0.000	0.02
2003/03/12	15:53:05	0.000	0.02
2003/03/12	15:53:10	0.000	0.04
2003/03/12	15:53:15	0.000	0.05
2003/03/12	15:53:20	0.000	0.04
2003/03/12	15:53:25	0.000	0.01
2003/03/12	15:53:30	0.000	0.06
2003/03/12	15:53:35	0.000	0.02
2003/03/12	15:53:40	0.000	0.02
2003/03/12	15:53:45	0.000	0.04
2003/03/12	15:53:50	0.000	0.01
2003/03/12	15:53:55	0.000	0.03
2003/03/12	15:54:00	0.000	0.02
2003/03/12	15:54:05	0.000	0.04
2003/03/12	15:54:10	0.000	0.04
2003/03/12	15:54:15	0.000	0.03
2003/03/12	15:54:20	0.000	0.04
2003/03/12	15:54:25	0.000	0.06
2003/03/12	15:54:30	0.000	0.05
2003/03/12	15:54:35	0.000	0.03
2003/03/12	15:54:40	0.000	0.07
2003/03/12	15:54:45	0.000	0.08
2003/03/12	15:54:50	0.000	0.03
2003/03/12	15:54:55	0.000	0.07
2003/03/12	15:55:00	0.000	0.03
2003/03/12	15:55:05	0.000	0.05
2003/03/12	15:55:10	0.000	0.04
2003/03/12	15:55:15	0.000	0.06
2003/03/12	15:55:20	0.000	0.04
2003/03/12	15:55:25	0.000	0.07
2003/03/12	15:55:30	0.000	0.08
2003/03/12	15:55:35	0.000	0.08
2003/03/12	15:55:40	0.000	0.08
2003/03/12	15:55:45	0.000	0.07
2003/03/12	15:55:50	0.000	0.08
2003/03/12	15:55:55	0.000	0.05
2003/03/12	15:56:00	0.000	0.00
2003/03/12	15:56:05	0.000	0.04
2003/03/12	15:56:10	0.000	-0.01
2003/03/12	15:56:15	0.000	0.00
2003/03/12	15:56:20	0.000	0.01
2003/03/12	15:56:25	0.000	-0.01
2003/03/12	15:56:30	0.000	0.03
2003/03/12	15:56:35	0.000	0.01
2003/03/12	15:56:40	0.000	0.01
2003/03/12	15:56:45	0.000	0.00
2003/03/12	15:56:50	0.000	0.05
2003/03/12	15:56:55	0.000	0.05
2003/03/12	15:57:00	0.000	0.00
2003/03/12	15:57:05	0.000	0.04
2003/03/12	15:57:10	0.000	-0.01
2003/03/12	15:57:15	0.000	0.10
2003/03/12	15:57:20	0.000	0.07
2003/03/12	15:57:25	0.000	0.03
2003/03/12	15:57:30	0.000	0.07
2003/03/12	15:57:35	0.000	0.03
2003/03/12	15:57:40	0.000	0.05
2003/03/12	15:57:45	0.000	0.02
2003/03/12	15:57:50	0.000	0.02
2003/03/12	15:57:55	0.000	0.02
2003/03/12	15:58:00	0.000	-0.01
2003/03/12	15:58:05	0.000	0.02
2003/03/12	15:58:10	0.000	0.01
2003/03/12	15:58:15	0.000	0.01
2003/03/12	15:58:20	0.000	0.00
2003/03/12	15:58:25	0.000	0.03
2003/03/12	15:58:30	0.000	0.01
2003/03/12	15:58:35	0.000	-0.02
2003/03/12	15:58:40	0.000	0.03
2003/03/12	15:58:45	0.000	-0.02
2003/03/12	15:58:50	0.000	0.00
2003/03/12	15:58:55	0.000	0.01
2003/03/12	15:59:00	0.000	0.00
2003/03/12	15:59:05	0.000	0.02
2003/03/12	15:59:10	0.000	-0.02
2003/03/12	15:59:15	0.000	0.01
2003/03/12	15:59:20	0.000	0.00
2003/03/12	15:59:25	0.000	0.00
2003/03/12	15:59:30	0.000	0.02

0.01

SEP 20 05 11:01:05

0.02

SEP 20 05 11:01:07

2003/03/12 16:59:35 0.000 0.03
2003/03/12 16:59:40 0.000 0.01
2003/03/12 16:59:45 0.000 -0.02
2003/03/12 16:59:50 0.000 0.03
2003/03/12 16:59:55 0.000 0.00
2003/03/12 16:00:00 0.000 -0.01
2003/03/12 16:00:05 0.000 0.02
2003/03/12 16:00:10 0.000 -0.01
2003/03/12 16:00:15 0.000 0.01
2003/03/12 16:00:20 0.000 -0.01
2003/03/12 16:00:25 0.000 0.01
2003/03/12 16:00:30 0.000 0.01
2003/03/12 16:00:35 0.000 -0.01
2003/03/12 16:00:40 0.000 0.01
2003/03/12 16:00:45 0.000 0.02
2003/03/12 16:00:50 0.000 0.01
2003/03/12 16:00:55 0.000 -0.01
2003/03/12 16:01:00 0.000 0.03
2003/03/12 16:01:05 0.000 0.01
2003/03/12 16:01:10 0.000 -0.01
2003/03/12 16:01:15 0.000 0.03
2003/03/12 16:01:20 0.000 -0.02
2003/03/12 16:01:25 0.000 0.00
2003/03/12 16:01:30 0.000 0.00
2003/03/12 16:01:35 0.000 0.00
2003/03/12 16:01:40 0.000 0.02
2003/03/12 16:01:45 0.000 -0.01
2003/03/12 16:01:50 0.000 0.01
2003/03/12 16:01:55 0.000 0.00
2003/03/12 16:02:00 0.000 0.01
2003/03/12 16:02:05 0.000 0.01
2003/03/12 16:02:10 0.000 0.03
2003/03/12 16:02:15 0.000 0.02
2003/03/12 16:02:20 0.000 -0.02
2003/03/12 16:02:25 0.000 0.03
2003/03/12 16:02:30 0.000 -0.01
2003/03/12 16:02:35 0.000 0.00
2003/03/12 16:02:40 0.000 0.01
2003/03/12 16:02:45 0.000 -0.01
2003/03/12 16:02:50 0.000 0.01
2003/03/12 16:02:55 0.000 -0.01
2003/03/12 16:03:00 0.000 0.01
2003/03/12 16:03:05 0.000 0.01
2003/03/12 16:03:10 0.000 0.00
2003/03/12 16:03:15 0.000 0.01
2003/03/12 16:03:20 0.000 0.03
2003/03/12 16:03:25 0.000 0.01
2003/03/12 16:03:30 0.000 -0.01
2003/03/12 16:03:35 0.000 0.03
2003/03/12 16:03:40 0.000 0.01
2003/03/12 16:03:45 0.000 -0.01
2003/03/12 16:03:50 0.000 0.02
2003/03/12 16:03:55 0.000 -0.01
2003/03/12 16:04:00 0.000 0.00
2003/03/12 16:04:05 0.000 -0.01
2003/03/12 16:04:10 0.000 0.01
2003/03/12 16:04:15 0.000 0.01
2003/03/12 16:04:20 0.000 -0.01
2003/03/12 16:04:25 0.000 0.02
2003/03/12 16:04:30 0.000 0.01
2003/03/12 16:04:35 0.000 0.01
2003/03/12 16:04:40 0.000 0.00
2003/03/12 16:04:45 0.000 0.03
2003/03/12 16:04:50 0.000 0.02
2003/03/12 16:04:55 0.000 -0.02
2003/03/12 16:05:00 0.000 0.03
2003/03/12 16:05:05 0.000 -0.01
2003/03/12 16:05:10 0.000 0.00
2003/03/12 16:05:15 0.000 0.00
2003/03/12 16:05:20 0.000 -0.01
2003/03/12 16:05:25 0.000 0.00
2003/03/12 16:05:30 0.000 -0.02
2003/03/12 16:05:35 0.000 0.01
2003/03/12 16:05:40 0.000 0.00
2003/03/12 16:05:45 0.000 0.00
2003/03/12 16:05:50 0.000 0.02
2003/03/12 16:05:55 0.000 0.03
2003/03/12 16:06:00 0.000 0.01
2003/03/12 16:06:05 0.000 -0.02
2003/03/12 16:06:10 0.000 0.03
2003/03/12 16:06:15 0.000 0.00
2003/03/12 16:06:20 0.000 0.02
2003/03/12 16:06:25 0.000 0.01
2003/03/12 16:06:30 0.000 0.03
2003/03/12 16:06:35 0.000 0.01
2003/03/12 16:06:40 0.000 -0.02
2003/03/12 16:06:45 0.000 0.03
2003/03/12 16:06:50 0.000 -0.01
2003/03/12 16:06:55 0.000 0.00
2003/03/12 16:07:00 0.000 0.01
2003/03/12 16:07:05 0.000 0.02
2003/03/12 16:07:10 0.000 0.01
2003/03/12 16:07:15 0.000 -0.01
2003/03/12 16:07:20 0.000 0.03
2003/03/12 16:07:25 0.000 0.01
2003/03/12 16:07:30 0.000 -0.01
2003/03/12 16:07:35 0.000 0.03
2003/03/12 16:07:40 0.000 -0.02
2003/03/12 16:07:45 0.000 0.01
2003/03/12 16:07:50 0.000 0.00
2003/03/12 16:07:55 0.000 0.00
2003/03/12 16:08:00 0.000 0.02
2003/03/12 16:08:05 0.000 -0.01
2003/03/12 16:08:10 0.000 0.01
2003/03/12 16:08:15 0.000 0.00
2003/03/12 16:08:20 0.000 0.01
2003/03/12 16:08:25 0.000 0.01
2003/03/12 16:08:30 0.000 0.03
2003/03/12 16:08:35 0.000 0.01
2003/03/12 16:08:40 0.000 -0.02
2003/03/12 16:08:45 0.000 0.03
2003/03/12 16:08:50 0.000 -0.01
2003/03/12 16:08:55 0.000 0.00
2003/03/12 16:09:00 0.000 0.01
2003/03/12 16:09:05 0.000 -0.01
2003/03/12 16:09:10 0.000 0.01
2003/03/12 16:09:15 0.000 -0.02
2003/03/12 16:09:20 0.000 0.01
2003/03/12 16:09:25 0.000 0.01
2003/03/12 16:09:30 0.000 0.00
2003/03/12 16:09:35 0.000 0.02
2003/03/12 16:09:40 0.000 0.03
2003/03/12 16:09:45 0.000 0.01
2003/03/12 16:09:50 0.000 -0.02
2003/03/12 16:09:55 0.000 0.03
2003/03/12 16:10:00 0.000 0.00
2003/03/12 16:10:05 0.000 -0.01
2003/03/12 16:10:10 0.000 0.02
2003/03/12 16:10:15 0.000 -0.02
2003/03/12 16:10:20 0.000 0.00
2003/03/12 16:10:25 0.000 -0.01
2003/03/12 16:10:30 0.000 0.01
2003/03/12 16:10:35 0.000 0.02
2003/03/12 16:10:40 0.000 -0.01

0.02

00:00:00 00:00:00

0.01

00:00:00 00:00:00

0.01

00:00:00 00:00:00

2003/03/12	16:10:45	0.000	0.01
2003/03/12	16:10:50	0.000	0.01
2003/03/12	16:10:55	0.000	0.01
2003/03/12	16:11:00	0.000	0.00
2003/03/12	16:11:05	0.000	0.03
2003/03/12	16:11:10	0.000	0.02
2003/03/12	16:11:15	0.000	-0.02
2003/03/12	16:11:20	0.000	0.03
2003/03/12	16:11:25	0.000	-0.02
2003/03/12	16:11:30	0.000	0.00
2003/03/12	16:11:35	0.000	0.00
2003/03/12	16:11:40	0.000	-0.01
2003/03/12	16:11:45	0.000	0.01
2003/03/12	16:11:50	0.000	-0.01
2003/03/12	16:11:55	0.000	0.02
2003/03/12	16:12:00	0.000	0.00
2003/03/12	16:12:05	0.000	0.00
2003/03/12	16:12:10	0.000	0.01
2003/03/12	16:12:15	0.000	0.03
2003/03/12	16:12:20	0.000	0.02
2003/03/12	16:12:25	0.000	-0.02
2003/03/12	16:12:30	0.000	0.03
2003/03/12	16:12:35	0.000	0.00
2003/03/12	16:12:40	0.000	-0.01
2003/03/12	16:12:45	0.000	0.02
2003/03/12	16:12:50	0.000	-0.01
2003/03/12	16:12:55	0.000	0.00
2003/03/12	16:13:00	0.000	-0.01
2003/03/12	16:13:05	0.000	0.01
2003/03/12	16:13:10	0.000	0.01
2003/03/12	16:13:15	0.000	0.00
2003/03/12	16:13:20	0.000	0.03
2003/03/12	16:13:25	0.000	0.03
2003/03/12	16:13:30	0.000	0.02
2003/03/12	16:13:35	0.000	0.00
2003/03/12	16:13:40	0.000	0.04
2003/03/12	16:13:45	0.000	0.03
2003/03/12	16:13:50	0.000	0.00
2003/03/12	16:13:55	0.000	0.05
2003/03/12	16:14:00	0.000	0.00
2003/03/12	16:14:05	0.000	0.03
2003/03/12	16:14:10	0.000	0.02
2003/03/12	16:14:15	0.000	0.02
2003/03/12	16:14:20	0.000	0.03
2003/03/12	16:14:25	0.000	0.01
2003/03/12	16:14:30	0.000	0.04
2003/03/12	16:14:35	0.000	0.03
2003/03/12	16:14:40	0.000	0.03
2003/03/12	16:14:45	0.000	0.04
2003/03/12	16:14:50	0.000	0.05
2003/03/12	16:14:55	0.000	0.03
2003/03/12	16:15:00	0.000	0.01
2003/03/12	16:15:05	0.000	0.05
2003/03/12	16:15:10	0.000	0.00
2003/03/12	16:15:15	0.000	0.00
2003/03/12	16:15:20	0.000	0.01
2003/03/12	16:15:25	0.000	-0.01
2003/03/12	16:15:30	0.000	0.01
2003/03/12	16:15:35	0.000	-0.02
2003/03/12	16:15:40	0.000	0.01
2003/03/12	16:15:45	0.000	0.01
2003/03/12	16:15:50	0.000	0.00
2003/03/12	16:15:55	0.000	0.02
2003/03/12	16:16:00	0.000	0.03
2003/03/12	16:16:05	0.000	0.01
2003/03/12	16:16:10	0.000	-0.01
2003/03/12	16:16:15	0.000	0.03
2003/03/12	16:16:20	0.000	0.00
2003/03/12	16:16:25	0.000	-0.01
2003/03/12	16:16:30	0.000	0.02
2003/03/12	16:16:35	0.000	-0.01
2003/03/12	16:16:40	0.000	0.01
2003/03/12	16:16:45	0.000	-0.01
2003/03/12	16:16:50	0.000	0.01
2003/03/12	16:16:55	0.000	0.02
2003/03/12	16:17:00	0.000	-0.01
2003/03/12	16:17:05	0.000	0.01
2003/03/12	16:17:10	0.000	0.02
2003/03/12	16:17:15	0.000	0.01
2003/03/12	16:17:20	0.000	0.00
2003/03/12	16:17:25	0.000	0.03
2003/03/12	16:17:30	0.000	0.01
2003/03/12	16:17:35	0.000	-0.01
2003/03/12	16:17:40	0.000	0.03
2003/03/12	16:17:45	0.000	-0.02
2003/03/12	16:17:50	0.000	0.00
2003/03/12	16:17:55	0.000	0.01
2003/03/12	16:18:00	0.000	0.00
2003/03/12	16:18:05	0.000	0.02
2003/03/12	16:18:10	0.000	-0.02
2003/03/12	16:18:15	0.000	0.01
2003/03/12	16:18:20	0.000	0.00
2003/03/12	16:18:25	0.000	0.00
2003/03/12	16:18:30	0.000	0.01
2003/03/12	16:18:35	0.000	0.03
2003/03/12	16:18:40	0.000	0.02
2003/03/12	16:18:45	0.000	-0.02
2003/03/12	16:18:50	0.000	0.03
2003/03/12	16:18:55	0.000	0.00
2003/03/12	16:19:00	0.000	-0.01
2003/03/12	16:19:05	0.000	0.02
2003/03/12	16:19:10	0.000	0.01
2003/03/12	16:19:15	0.000	0.02
2003/03/12	16:19:20	0.000	0.01
2003/03/12	16:19:25	0.000	0.01
2003/03/12	16:19:30	0.000	0.01
2003/03/12	16:19:35	0.000	-0.01
2003/03/12	16:19:40	0.000	0.01
2003/03/12	16:19:45	0.000	0.02
2003/03/12	16:19:50	0.000	0.01
2003/03/12	16:19:55	0.000	-0.01
2003/03/12	16:20:00	0.000	0.03
2003/03/12	16:20:05	0.000	0.02
2003/03/12	16:20:10	0.000	-0.01
2003/03/12	16:20:15	0.000	0.03
2003/03/12	16:20:20	0.000	-0.02
2003/03/12	16:20:25	0.000	0.00
2003/03/12	16:20:30	0.000	0.00
2003/03/12	16:20:35	0.000	0.00
2003/03/12	16:20:40	0.000	0.01
2003/03/12	16:20:45	0.000	-0.01
2003/03/12	16:20:50	0.000	0.02
2003/03/12	16:20:55	0.000	0.01
2003/03/12	16:21:00	0.000	0.01
2003/03/12	16:21:05	0.000	0.00
2003/03/12	16:21:10	0.000	0.03
2003/03/12	16:21:15	0.000	0.02
2003/03/12	16:21:20	0.000	-0.02
2003/03/12	16:21:25	0.000	0.03
2003/03/12	16:21:30	0.000	-0.01
2003/03/12	16:21:35	0.000	0.00
2003/03/12	16:21:40	0.000	0.01
2003/03/12	16:21:45	0.000	-0.01
2003/03/12	16:21:50	0.000	0.00

0.01

XXXXXXXXXXXXXXXXXXXX

0.01

XXXXXXXXXXXXXXXXXXXX

2003/03/12	16:21:55	0.000	-0.02
2003/03/12	16:22:00	0.000	0.01
2003/03/12	16:22:05	0.000	0.01
2003/03/12	16:22:10	0.000	0.00
2003/03/12	16:22:15	0.000	0.02
2003/03/12	16:22:20	0.000	0.03
2003/03/12	16:22:25	0.000	0.01
2003/03/12	16:22:30	0.000	-0.01
2003/03/12	16:22:35	0.000	0.03
2003/03/12	16:22:40	0.000	0.00
2003/03/12	16:22:45	0.000	-0.01
2003/03/12	16:22:50	0.000	0.02
2003/03/12	16:22:55	0.000	-0.01
2003/03/12	16:23:00	0.000	0.01
2003/03/12	16:23:05	0.000	-0.01
2003/03/12	16:23:10	0.000	0.01
2003/03/12	16:23:15	0.000	0.01
2003/03/12	16:23:20	0.000	-0.01
2003/03/12	16:23:25	0.000	0.02
2003/03/12	16:23:30	0.000	0.01
2003/03/12	16:23:35	0.000	0.01
2003/03/12	16:23:40	0.000	0.00
2003/03/12	16:23:45	0.000	0.03
2003/03/12	16:23:50	0.000	0.01
2003/03/12	16:23:55	0.000	-0.02
2003/03/12	16:24:00	0.000	0.03
2003/03/12	16:24:05	0.000	-0.02
2003/03/12	16:24:10	0.000	0.00
2003/03/12	16:24:15	0.000	0.00
2003/03/12	16:24:20	0.000	0.00
2003/03/12	16:24:25	0.000	0.02
2003/03/12	16:24:30	0.000	-0.02
2003/03/12	16:24:35	0.000	0.01
2003/03/12	16:24:40	0.000	0.00
2003/03/12	16:24:45	0.000	0.01
2003/03/12	16:24:50	0.000	0.02
2003/03/12	16:24:55	0.000	0.03
2003/03/12	16:25:00	0.000	0.01
2003/03/12	16:25:05	0.000	-0.02
2003/03/12	16:25:10	0.000	0.03
2003/03/12	16:25:15	0.000	-0.01
2003/03/12	16:25:20	0.000	0.00
2003/03/12	16:25:25	0.000	0.02
2003/03/12	16:25:30	0.000	-0.01
2003/03/12	16:25:35	0.000	0.01
2003/03/12	16:25:40	0.000	-0.01
2003/03/12	16:25:45	0.000	-0.01
2003/03/12	16:25:50	0.000	0.01
2003/03/12	16:25:55	0.000	0.01
2003/03/12	16:26:00	0.000	-0.01
2003/03/12	16:26:05	0.000	0.02
2003/03/12	16:26:10	0.000	0.02
2003/03/12	16:26:15	0.000	0.01
2003/03/12	16:26:20	0.000	-0.01
2003/03/12	16:26:25	0.000	0.03
2003/03/12	16:26:30	0.000	0.01
2003/03/12	16:26:35	0.000	-0.01
2003/03/12	16:26:40	0.000	0.03
2003/03/12	16:26:45	0.000	-0.02
2003/03/12	16:26:50	0.000	0.00
2003/03/12	16:26:55	0.000	0.00
2003/03/12	16:27:00	0.000	0.02
2003/03/12	16:27:05	0.000	-0.01
2003/03/12	16:27:10	0.000	0.01
2003/03/12	16:27:15	0.000	0.01
2003/03/12	16:27:20	0.000	0.01
2003/03/12	16:27:25	0.000	0.00
2003/03/12	16:27:30	0.000	0.03
2003/03/12	16:27:35	0.000	0.02
2003/03/12	16:27:40	0.000	-0.02
2003/03/12	16:27:45	0.000	0.03
2003/03/12	16:27:50	0.000	-0.01
2003/03/12	16:27:55	0.000	0.00
2003/03/12	16:28:00	0.000	0.01
2003/03/12	16:28:05	0.000	-0.01
2003/03/12	16:28:10	0.000	0.01
2003/03/12	16:28:15	0.000	-0.01
2003/03/12	16:28:20	0.000	0.01
2003/03/12	16:28:25	0.000	0.01
2003/03/12	16:28:30	0.000	0.00
2003/03/12	16:28:35	0.000	0.01
2003/03/12	16:28:40	0.000	0.03
2003/03/12	16:28:45	0.000	0.01
2003/03/12	16:28:50	0.000	-0.01
2003/03/12	16:28:55	0.000	0.04
2003/03/12	16:29:00	0.000	0.01
2003/03/12	16:29:05	0.000	0.00
2003/03/12	16:29:10	0.000	0.03
2003/03/12	16:29:15	0.000	0.00
2003/03/12	16:29:20	0.000	0.02
2003/03/12	16:29:25	0.000	0.00
2003/03/12	16:29:30	0.000	0.02
2003/03/12	16:29:35	0.000	0.03
2003/03/12	16:29:40	0.000	0.01
2003/03/12	16:29:45	0.000	0.04
2003/03/12	16:29:50	0.000	0.04
2003/03/12	16:29:55	0.003	0.03
2003/03/12	16:30:00	0.000	0.01
2003/03/12	16:30:05	0.000	0.05
2003/03/12	16:30:10	0.000	0.04
2003/03/12	16:30:15	0.000	0.01
2003/03/12	16:30:20	0.000	0.05
2003/03/12	16:30:25	0.000	0.01
2003/03/12	16:30:30	0.000	0.03
2003/03/12	16:30:35	0.000	0.03
2003/03/12	16:30:40	0.000	0.02
2003/03/12	16:30:45	0.000	0.03
2003/03/12	16:30:50	0.000	0.02
2003/03/12	16:30:55	0.000	0.04
2003/03/12	16:31:00	0.000	0.04
2003/03/12	16:31:05	0.000	0.04
2003/03/12	16:31:10	0.000	0.05
2003/03/12	16:31:15	0.003	0.07
2003/03/12	16:31:20	0.000	0.05
2003/03/12	16:31:25	0.000	0.02
2003/03/12	16:31:30	0.000	0.07
2003/03/12	16:31:35	0.000	0.04
2003/03/12	16:31:40	0.000	0.04
2003/03/12	16:31:45	0.000	0.06
2003/03/12	16:31:50	0.000	0.04
2003/03/12	16:31:55	0.000	0.06
2003/03/12	16:32:00	0.000	0.03
2003/03/12	16:32:05	0.000	0.06
2003/03/12	16:32:10	0.003	0.06
2003/03/12	16:32:15	0.000	0.06
2003/03/12	16:32:20	0.000	0.07
2003/03/12	16:32:25	0.000	0.07
2003/03/12	16:32:30	0.000	0.04
2003/03/12	16:32:35	0.000	0.01
2003/03/12	16:32:40	0.000	0.04
2003/03/12	16:32:45	0.000	0.01
2003/03/12	16:32:50	0.000	-0.01
2003/03/12	16:32:55	0.000	0.03
2003/03/12	16:33:00	0.000	-0.02

0.01

16:24:00

0.01

16:29:00

2003/03/12	16:33:05	0.000	0.01
2003/03/12	16:33:10	0.000	-0.01
2003/03/12	16:33:15	0.000	0.01
2003/03/12	16:33:20	0.000	0.02
2003/03/12	16:33:25	0.000	-0.01
2003/03/12	16:33:30	0.000	0.04
2003/03/12	16:33:35	0.000	0.00
2003/03/12	16:33:40	0.000	0.07
2003/03/12	16:33:45	0.000	0.06
2003/03/12	16:33:50	0.000	0.10
2003/03/12	16:33:55	0.000	0.08
2003/03/12	16:34:00	0.000	0.08
2003/03/12	16:34:05	0.000	0.10
2003/03/12	16:34:10	0.000	0.04
2003/03/12	16:34:15	0.000	0.04
2003/03/12	16:34:20	0.000	0.03
2003/03/12	16:34:25	0.000	0.01
2003/03/12	16:34:30	0.000	0.02
2003/03/12	16:34:35	0.000	-0.02
2003/03/12	16:34:40	0.000	0.01
2003/03/12	16:34:45	0.000	0.00
2003/03/12	16:34:50	0.000	0.00
2003/03/12	16:34:55	0.000	0.01
2003/03/12	16:35:00	0.000	0.03
2003/03/12	16:35:05	0.000	0.02
2003/03/12	16:35:10	0.000	-0.02
2003/03/12	16:35:15	0.000	0.03
2003/03/12	16:35:20	0.000	0.00
2003/03/12	16:35:25	0.000	-0.01
2003/03/12	16:35:30	0.000	0.02
2003/03/12	16:35:35	0.000	-0.01
2003/03/12	16:35:40	0.000	0.01
2003/03/12	16:35:45	0.000	-0.01
2003/03/12	16:35:50	0.000	0.01
2003/03/12	16:35:55	0.000	0.01
2003/03/12	16:36:00	0.000	-0.01
2003/03/12	16:36:05	0.000	0.01
2003/03/12	16:36:10	0.000	0.02
2003/03/12	16:36:15	0.000	0.01
2003/03/12	16:36:20	0.000	-0.01
2003/03/12	16:36:25	0.000	0.03
2003/03/12	16:36:30	0.000	0.02
2003/03/12	16:36:35	0.000	-0.01
2003/03/12	16:36:40	0.000	0.03
2003/03/12	16:36:45	0.000	-0.02
2003/03/12	16:36:50	0.000	0.00
2003/03/12	16:36:55	0.000	0.00
2003/03/12	16:37:00	0.000	0.00
2003/03/12	16:37:05	0.000	0.01
2003/03/12	16:37:10	0.000	-0.01
2003/03/12	16:37:15	0.000	0.03
2003/03/12	16:37:20	0.000	0.03
2003/03/12	16:37:25	0.000	0.04
2003/03/12	16:37:30	0.000	0.05
2003/03/12	16:37:35	0.000	0.08
2003/03/12	16:37:40	0.000	0.08
2003/03/12	16:37:45	0.000	0.05
2003/03/12	16:37:50	0.000	0.11
2003/03/12	16:37:55	0.000	0.08
2003/03/12	16:38:00	0.000	0.06
2003/03/12	16:38:05	0.000	0.11
2003/03/12	16:38:10	0.000	0.10
2003/03/12	16:38:15	0.000	0.11
2003/03/12	16:38:20	0.000	0.10
2003/03/12	16:38:25	0.000	0.13
2003/03/12	16:38:30	0.000	0.13
2003/03/12	16:38:35	0.000	0.12
2003/03/12	16:38:40	0.000	0.14
2003/03/12	16:38:45	0.000	0.15
2003/03/12	16:38:50	0.000	0.13
2003/03/12	16:38:55	0.000	0.11
2003/03/12	16:39:00	0.000	0.16
2003/03/12	16:39:05	0.000	0.13
2003/03/12	16:39:10	0.000	0.12
2003/03/12	16:39:15	0.000	0.16
2003/03/12	16:39:20	0.000	0.11
2003/03/12	16:39:25	0.000	0.14
2003/03/12	16:39:30	0.000	0.12
2003/03/12	16:39:35	0.000	0.13
2003/03/12	16:39:40	0.000	0.14
2003/03/12	16:39:45	0.000	0.13
2003/03/12	16:39:50	0.000	0.15
2003/03/12	16:39:55	0.000	0.15
2003/03/12	16:40:00	0.000	0.15
2003/03/12	16:40:05	0.000	0.14
2003/03/12	16:40:10	0.000	0.18
2003/03/12	16:40:15	0.000	0.18
2003/03/12	16:40:20	0.000	0.13
2003/03/12	16:40:25	0.000	0.18
2003/03/12	16:40:30	0.000	0.13
2003/03/12	16:40:35	0.000	0.16
2003/03/12	16:40:40	0.000	0.16
2003/03/12	16:40:45	0.000	0.15
2003/03/12	16:40:50	0.000	0.17
2003/03/12	16:40:55	0.000	0.14
2003/03/12	16:41:00	0.000	0.17
2003/03/12	16:41:05	0.000	0.16
2003/03/12	16:41:10	0.000	0.16
2003/03/12	16:41:15	0.000	0.17
2003/03/12	16:41:20	0.000	0.19
2003/03/12	16:41:25	0.000	0.17
2003/03/12	16:41:30	0.000	0.14
2003/03/12	16:41:35	0.000	0.19
2003/03/12	16:41:40	0.000	0.16
2003/03/12	16:41:45	0.000	0.16
2003/03/12	16:41:50	0.000	0.18
2003/03/12	16:41:55	0.000	0.18
2003/03/12	16:42:00	0.000	0.18
2003/03/12	16:42:05	0.000	0.16
2003/03/12	16:42:10	0.000	0.18
2003/03/12	16:42:15	0.000	0.18
2003/03/12	16:42:20	0.000	0.17
2003/03/12	16:42:25	0.000	0.19
2003/03/12	16:42:30	0.000	0.20
2003/03/12	16:42:35	0.000	0.19
2003/03/12	16:42:40	0.000	0.16
2003/03/12	16:42:45	0.000	0.21
2003/03/12	16:42:50	0.000	0.18
2003/03/12	16:42:55	0.000	0.17
2003/03/12	16:43:00	0.000	0.20
2003/03/12	16:43:05	0.000	0.18
2003/03/12	16:43:10	0.000	0.18
2003/03/12	16:43:15	0.000	0.17
2003/03/12	16:43:20	0.000	0.18
2003/03/12	16:43:25	0.000	0.19
2003/03/12	16:43:30	0.000	0.18
2003/03/12	16:43:35	0.000	0.18
2003/03/12	16:43:40	0.000	0.18
2003/03/12	16:43:45	0.000	0.18
2003/03/12	16:43:50	0.000	0.18
2003/03/12	16:43:55	0.000	0.18
2003/03/12	16:44:00	0.000	0.18
2003/03/12	16:44:05	0.000	0.14
2003/03/12	16:44:10	0.000	0.18

0.03

0.03

0.06

0.06

2003/03/12	18:44:15	0.000	0.14
2003/03/12	18:44:20	0.000	0.15
2003/03/12	18:44:25	0.000	0.16
2003/03/12	18:44:30	0.000	0.14
2003/03/12	18:44:35	0.000	0.16
2003/03/12	18:44:40	0.000	0.12
2003/03/12	18:44:45	0.000	0.15
2003/03/12	18:44:50	0.000	0.14
2003/03/12	18:44:55	0.000	0.13
2003/03/12	18:45:00	0.000	0.14
2003/03/12	18:45:05	0.000	0.16
2003/03/12	18:45:10	0.000	0.14
2003/03/12	18:45:15	0.000	0.11
2003/03/12	18:45:20	0.000	0.15
2003/03/12	18:45:25	0.000	0.12
2003/03/12	18:45:30	0.000	0.11
2003/03/12	18:45:35	0.000	0.12
2003/03/12	18:45:40	0.000	0.09
2003/03/12	18:45:45	0.000	0.10
2003/03/12	18:45:50	0.000	0.08
2003/03/12	18:45:55	0.000	0.10
2003/03/12	18:46:00	0.000	0.09
2003/03/12	18:46:05	0.000	0.08
2003/03/12	18:46:10	0.000	0.09
2003/03/12	18:46:15	0.000	0.09
2003/03/12	18:46:20	0.000	0.07
2003/03/12	18:46:25	0.000	0.04
2003/03/12	18:46:30	0.000	0.09
2003/03/12	18:46:35	0.000	0.08
2003/03/12	18:46:40	0.000	0.09
2003/03/12	18:46:45	0.000	0.06
2003/03/12	18:46:50	0.000	0.02
2003/03/12	18:46:55	0.000	0.04
2003/03/12	18:47:00	0.000	0.03
2003/03/12	18:47:05	0.000	0.03
2003/03/12	18:47:10	0.000	0.03
2003/03/12	18:47:15	0.000	0.01
2003/03/12	18:47:20	0.000	0.04
2003/03/12	18:47:25	0.000	0.04
2003/03/12	18:47:30	0.000	0.04
2003/03/12	18:47:35	0.000	0.04
2003/03/12	18:47:40	0.000	0.06
2003/03/12	18:47:45	0.000	0.04
2003/03/12	18:47:50	0.000	0.02
2003/03/12	18:47:55	0.000	0.07
2003/03/12	18:48:00	0.000	0.02
2003/03/12	18:48:05	0.000	0.04
2003/03/12	18:48:10	0.000	0.05
2003/03/12	18:48:15	0.000	0.03
2003/03/12	18:48:20	0.000	0.06
2003/03/12	18:48:25	0.000	0.02
2003/03/12	18:48:30	0.000	0.05
2003/03/12	18:48:35	0.000	0.05
2003/03/12	18:48:40	0.000	0.04
2003/03/12	18:48:45	0.000	0.07
2003/03/12	18:48:50	0.000	0.07
2003/03/12	18:48:55	0.000	0.06
2003/03/12	18:49:00	0.000	0.03
2003/03/12	18:49:05	0.000	0.08
2003/03/12	18:49:10	0.000	0.08
2003/03/12	18:49:15	0.000	0.04
2003/03/12	18:49:20	0.000	0.08
2003/03/12	18:49:25	0.000	0.04
2003/03/12	18:49:30	0.000	0.06
2003/03/12	18:49:35	0.000	0.05
2003/03/12	18:49:40	0.000	0.07
2003/03/12	18:49:45	0.000	0.08
2003/03/12	18:49:50	0.000	0.06
2003/03/12	18:49:55	0.000	0.09
2003/03/12	18:50:00	0.000	0.10
2003/03/12	18:50:05	0.000	0.09
2003/03/12	18:50:10	0.000	0.08
2003/03/12	18:50:15	0.000	0.12
2003/03/12	18:50:20	0.000	0.10
2003/03/12	18:50:25	0.000	0.08
2003/03/12	18:50:30	0.000	0.12
2003/03/12	18:50:35	0.000	0.08
2003/03/12	18:50:40	0.000	0.11
2003/03/12	18:50:45	0.000	0.11
2003/03/12	18:50:50	0.000	0.11
2003/03/12	18:50:55	0.000	0.14
2003/03/12	18:51:00	0.000	0.11
2003/03/12	18:51:05	0.000	0.14
2003/03/12	18:51:10	0.000	0.14
2003/03/12	18:51:15	0.000	0.13
2003/03/12	18:51:20	0.000	0.14
2003/03/12	18:51:25	0.000	0.15
2003/03/12	18:51:30	0.000	0.12
2003/03/12	18:51:35	0.000	0.04
2003/03/12	18:51:40	0.000	0.07
2003/03/12	18:51:45	0.000	0.02
2003/03/12	18:51:50	0.000	0.02
2003/03/12	18:51:55	0.000	0.02
2003/03/12	18:52:00	0.000	-0.01
2003/03/12	18:52:05	0.000	0.01
2003/03/12	18:52:10	0.000	-0.01
2003/03/12	18:52:15	0.000	0.01
2003/03/12	18:52:20	0.000	0.01
2003/03/12	18:52:25	0.000	0.00
2003/03/12	18:52:30	0.000	0.01
2003/03/12	18:52:35	0.000	0.03
2003/03/12	18:52:40	0.000	0.04
2003/03/12	18:52:45	0.000	0.03
2003/03/12	18:52:50	0.000	0.07
2003/03/12	18:52:55	0.000	0.04
2003/03/12	18:53:00	0.000	0.01
2003/03/12	18:53:05	0.000	0.04
2003/03/12	18:53:10	0.000	-0.01
2003/03/12	18:53:15	0.000	0.00
2003/03/12	18:53:20	0.000	-0.01
2003/03/12	18:53:25	0.000	0.00
2003/03/12	18:53:30	0.000	0.01
2003/03/12	18:53:35	0.000	-0.01
2003/03/12	18:53:40	0.000	0.02
2003/03/12	18:53:45	0.000	0.01
2003/03/12	18:53:50	0.000	0.01
2003/03/12	18:53:55	0.000	0.00
2003/03/12	18:54:00	0.000	0.03
2003/03/12	18:54:05	0.000	0.02
2003/03/12	18:54:10	0.000	-0.02
2003/03/12	18:54:15	0.000	0.03
2003/03/12	18:54:20	0.000	-0.01
2003/03/12	18:54:25	0.000	0.00
2003/03/12	18:54:30	0.000	0.00
2003/03/12	18:54:35	0.000	-0.01
2003/03/12	18:54:40	0.000	0.00
2003/03/12	18:54:45	0.000	-0.02
2003/03/12	18:54:50	0.000	0.02
2003/03/12	18:54:55	0.000	0.02
2003/03/12	18:55:00	0.000	0.02
2003/03/12	18:55:05	0.000	0.06
2003/03/12	18:55:10	0.000	0.06
2003/03/12	18:55:15	0.000	0.05
2003/03/12	18:55:20	0.000	0.02

0.17

0.17

0.06

0.06

0.05

0.05

2003/03/12	16:55:25	0.000	0.08
2003/03/12	16:55:30	0.000	0.06
2003/03/12	16:55:35	0.000	0.05
2003/03/12	16:55:40	0.000	0.07
2003/03/12	16:55:45	0.000	0.05
2003/03/12	16:55:50	0.000	0.07
2003/03/12	16:55:55	0.000	0.04
2003/03/12	16:56:00	0.000	0.07
2003/03/12	16:56:05	0.000	0.07
2003/03/12	16:56:10	0.000	0.05
2003/03/12	16:56:15	0.000	0.08
2003/03/12	16:56:20	0.000	0.09
2003/03/12	16:56:25	0.000	0.07
2003/03/12	16:56:30	0.000	0.05
2003/03/12	16:56:35	0.000	0.09
2003/03/12	16:56:40	0.000	0.07
2003/03/12	16:56:45	0.000	0.04
2003/03/12	16:56:50	0.000	0.08
2003/03/12	16:56:55	0.000	0.04
2003/03/12	16:57:00	0.000	0.08
2003/03/12	16:57:05	0.000	0.05
2003/03/12	16:57:10	0.000	0.05
2003/03/12	16:57:15	0.000	0.07
2003/03/12	16:57:20	0.000	0.04
2003/03/12	16:57:25	0.000	0.07
2003/03/12	16:57:30	0.000	0.07
2003/03/12	16:57:35	0.000	0.08
2003/03/12	16:57:40	0.000	0.08
2003/03/12	16:57:45	0.000	0.08
2003/03/12	16:57:50	0.000	0.08
2003/03/12	16:57:55	0.000	0.04
2003/03/12	16:58:00	0.000	0.08
2003/03/12	16:58:05	0.000	0.04
2003/03/12	16:58:10	0.000	0.05
2003/03/12	16:58:15	0.000	0.08
2003/03/12	16:58:20	0.000	0.04
2003/03/12	16:58:25	0.000	0.08
2003/03/12	16:58:30	0.000	0.03
2003/03/12	16:58:35	0.000	0.05
2003/03/12	16:58:40	0.000	0.03
2003/03/12	16:58:45	0.000	0.05
2003/03/12	16:58:50	0.000	0.08
2003/03/12	16:58:55	0.000	0.07
2003/03/12	16:59:00	0.000	0.08
2003/03/12	16:59:05	0.000	0.03
2003/03/12	16:59:10	0.000	0.08
2003/03/12	16:59:15	0.000	0.05
2003/03/12	16:59:20	0.000	0.03
2003/03/12	16:59:25	0.000	0.07
2003/03/12	16:59:30	0.000	0.03
2003/03/12	16:59:35	0.000	0.05
2003/03/12	16:59:40	0.000	0.03
2003/03/12	16:59:45	0.000	0.05
2003/03/12	16:59:50	0.000	0.08
2003/03/12	16:59:55	0.000	0.03
2003/03/12	17:00:00	0.000	0.08
2003/03/12	17:00:05	0.000	0.08
2003/03/12	17:00:10	0.000	0.05
2003/03/12	17:00:15	0.000	0.04
2003/03/12	17:00:20	0.000	0.08
2003/03/12	17:00:25	0.000	0.08
2003/03/12	17:00:30	0.000	0.03
2003/03/12	17:00:35	0.000	0.07
2003/03/12	17:00:40	0.000	0.03
2003/03/12	17:00:45	0.000	0.08
2003/03/12	17:00:50	0.000	0.04
2003/03/12	17:00:55	0.000	0.04
2003/03/12	17:01:00	0.000	0.05
2003/03/12	17:01:05	0.000	0.03
2003/03/12	17:01:10	0.000	0.08
2003/03/12	17:01:15	0.000	0.05
2003/03/12	17:01:20	0.000	0.05
2003/03/12	17:01:25	0.000	0.05
2003/03/12	17:01:30	0.000	0.08
2003/03/12	17:01:35	0.000	0.08
2003/03/12	17:01:40	0.000	0.03
2003/03/12	17:01:45	0.000	0.08
2003/03/12	17:01:50	0.000	0.03
2003/03/12	17:01:55	0.000	0.04
2003/03/12	17:02:00	0.000	0.08
2003/03/12	17:02:05	0.000	0.03
2003/03/12	17:02:10	0.000	0.05
2003/03/12	17:02:15	0.000	0.03
2003/03/12	17:02:20	0.000	0.05
2003/03/12	17:02:25	0.000	0.06
2003/03/12	17:02:30	0.000	0.04
2003/03/12	17:02:35	0.000	0.07
2003/03/12	17:02:40	0.000	0.07
2003/03/12	17:02:45	0.000	0.05
2003/03/12	17:02:50	0.000	0.03
2003/03/12	17:02:55	0.000	0.08
2003/03/12	17:03:00	0.000	0.08
2003/03/12	17:03:05	0.000	0.04
2003/03/12	17:03:10	0.000	0.07
2003/03/12	17:03:15	0.000	0.03
2003/03/12	17:03:20	0.000	0.08
2003/03/12	17:03:25	0.000	0.04
2003/03/12	17:03:30	0.000	0.08
2003/03/12	17:03:35	0.000	0.08
2003/03/12	17:03:40	0.000	0.04
2003/03/12	17:03:45	0.000	0.07
2003/03/12	17:03:50	0.000	0.07
2003/03/12	17:03:55	0.000	0.08
2003/03/12	17:04:00	0.000	0.08
2003/03/12	17:04:05	0.000	0.08
2003/03/12	17:04:10	0.000	0.08
2003/03/12	17:04:15	0.000	0.03
2003/03/12	17:04:20	0.000	0.08
2003/03/12	17:04:25	0.000	0.03
2003/03/12	17:04:30	0.000	0.05
2003/03/12	17:04:35	0.000	0.08
2003/03/12	17:04:40	0.000	0.05
2003/03/12	17:04:45	0.000	0.07
2003/03/12	17:04:50	0.000	0.04
2003/03/12	17:04:55	0.000	0.07
2003/03/12	17:05:00	0.000	0.08
2003/03/12	17:05:05	0.000	0.08
2003/03/12	17:05:10	0.000	0.08
2003/03/12	17:05:15	0.000	0.09
2003/03/12	17:05:20	0.000	0.07
2003/03/12	17:05:25	0.000	0.04
2003/03/12	17:05:30	0.000	0.10
2003/03/12	17:05:35	0.000	0.06
2003/03/12	17:05:40	0.000	0.08
2003/03/12	17:05:45	0.000	0.08
2003/03/12	17:05:50	0.000	0.08
2003/03/12	17:05:55	0.000	0.08
2003/03/12	17:06:00	0.000	0.05
2003/03/12	17:06:05	0.000	0.08
2003/03/12	17:06:10	0.000	0.09
2003/03/12	17:06:15	0.000	0.08
2003/03/12	17:06:20	0.000	0.09
2003/03/12	17:06:25	0.000	0.10
2003/03/12	17:06:30	0.000	0.09

0.08

PROFESSOR

0.05

PROFESSOR

2003/03/12	17:08:35	0.000	0.07
2003/03/12	17:08:40	0.000	0.11
2003/03/12	17:08:45	0.000	0.09
2003/03/12	17:08:50	0.000	0.07
2003/03/12	17:08:55	0.000	0.11
2003/03/12	17:07:00	0.000	0.07
2003/03/12	17:07:05	0.000	0.09
2003/03/12	17:07:10	0.000	0.09
2003/03/12	17:07:15	0.000	0.09
2003/03/12	17:07:20	0.000	0.11
2003/03/12	17:07:25	0.000	0.09
2003/03/12	17:07:30	0.000	0.10
2003/03/12	17:07:35	0.000	0.11
2003/03/12	17:07:40	0.000	0.10
2003/03/12	17:07:45	0.000	0.10
2003/03/12	17:07:50	0.000	0.12
2003/03/12	17:07:55	0.000	0.12
2003/03/12	17:08:00	0.000	0.08
2003/03/12	17:08:05	0.000	0.13
2003/03/12	17:08:10	0.000	0.09
2003/03/12	17:08:15	0.000	0.11
2003/03/12	17:08:20	0.000	0.12
2003/03/12	17:08:25	0.000	0.10
2003/03/12	17:08:30	0.000	0.13
2003/03/12	17:08:35	0.000	0.11
2003/03/12	17:08:40	0.000	0.14
2003/03/12	17:08:45	0.000	0.14
2003/03/12	17:08:50	0.000	0.13
2003/03/12	17:08:55	0.000	0.14
2003/03/12	17:09:00	0.000	0.16
2003/03/12	17:09:05	0.000	0.15
2003/03/12	17:09:10	0.000	0.11
2003/03/12	17:09:15	0.000	0.12
2003/03/12	17:09:20	0.000	0.07
2003/03/12	17:09:25	0.000	0.03
2003/03/12	17:09:30	0.000	0.06
2003/03/12	17:09:35	0.000	0.00
2003/03/12	17:09:40	0.000	0.01
2003/03/12	17:09:45	0.000	-0.01
2003/03/12	17:09:50	0.000	0.01
2003/03/12	17:09:55	0.000	0.01
2003/03/12	17:10:00	0.000	-0.01
2003/03/12	17:10:05	0.000	0.02
2003/03/12	17:10:10	0.000	0.03
2003/03/12	17:10:15	0.000	0.06
2003/03/12	17:10:20	0.000	0.07
2003/03/12	17:10:25	0.000	0.13
2003/03/12	17:10:30	0.000	0.14
2003/03/12	17:10:35	0.000	0.12
2003/03/12	17:10:40	0.000	0.18
2003/03/12	17:10:45	0.000	0.13
2003/03/12	17:10:50	0.000	0.16
2003/03/12	17:10:55	0.000	0.13
2003/03/12	17:11:00	0.000	0.10
2003/03/12	17:11:05	0.000	0.07
2003/03/12	17:11:10	0.000	0.03
2003/03/12	17:11:15	0.000	0.04
2003/03/12	17:11:20	0.000	0.02
2003/03/12	17:11:25	0.000	0.01
2003/03/12	17:11:30	0.000	0.01
2003/03/12	17:11:35	0.000	0.03
2003/03/12	17:11:40	0.000	0.01
2003/03/12	17:11:45	0.000	-0.02
2003/03/12	17:11:50	0.000	0.03
2003/03/12	17:11:55	0.000	-0.01
2003/03/12	17:12:00	0.000	0.00
2003/03/12	17:12:05	0.000	0.01
2003/03/12	17:12:10	0.000	-0.01
2003/03/12	17:12:15	0.000	0.01
2003/03/12	17:12:20	0.000	-0.02
2003/03/12	17:12:25	0.000	0.01
2003/03/12	17:12:30	0.000	0.01
2003/03/12	17:12:35	0.000	0.00
2003/03/12	17:12:40	0.000	0.02
2003/03/12	17:12:45	0.000	0.02
2003/03/12	17:12:50	0.000	0.01
2003/03/12	17:12:55	0.000	-0.01
2003/03/12	17:13:00	0.000	0.03
2003/03/12	17:13:05	0.000	0.01
2003/03/12	17:13:10	0.000	-0.01
2003/03/12	17:13:15	0.000	0.03
2003/03/12	17:13:20	0.000	-0.02
2003/03/12	17:13:25	0.000	0.01
2003/03/12	17:13:30	0.000	-0.01
2003/03/12	17:13:35	0.000	0.01
2003/03/12	17:13:40	0.000	0.02
2003/03/12	17:13:45	0.000	-0.01
2003/03/12	17:13:50	0.000	0.03
2003/03/12	17:13:55	0.000	0.03
2003/03/12	17:14:00	0.000	0.04
2003/03/12	17:14:05	0.000	0.03
2003/03/12	17:14:10	0.000	0.07
2003/03/12	17:14:15	0.000	0.05
2003/03/12	17:14:20	0.000	0.03
2003/03/12	17:14:25	0.000	0.08
2003/03/12	17:14:30	0.000	0.04
2003/03/12	17:14:35	0.000	0.08
2003/03/12	17:14:40	0.000	0.07
2003/03/12	17:14:45	0.000	0.08
2003/03/12	17:14:50	0.000	0.08
2003/03/12	17:14:55	0.000	0.05
2003/03/12	17:15:00	0.000	0.03
2003/03/12	17:15:05	0.000	0.03
2003/03/12	17:15:10	0.000	0.07
2003/03/12	17:15:15	0.000	0.08
2003/03/12	17:15:20	0.000	0.10
2003/03/12	17:15:25	0.000	0.09
2003/03/12	17:15:30	0.000	0.06
2003/03/12	17:15:35	0.000	0.10
2003/03/12	17:15:40	0.000	0.07
2003/03/12	17:15:45	0.000	0.07
2003/03/12	17:15:50	0.000	0.09
2003/03/12	17:15:55	0.000	0.06
2003/03/12	17:16:00	0.000	0.08
2003/03/12	17:16:05	0.000	0.08
2003/03/12	17:16:10	0.000	0.09
2003/03/12	17:16:15	0.000	0.08
2003/03/12	17:16:20	0.000	0.07
2003/03/12	17:16:25	0.000	0.08
2003/03/12	17:16:30	0.000	0.11
2003/03/12	17:16:35	0.000	0.09
2003/03/12	17:16:40	0.000	0.07
2003/03/12	17:16:45	0.000	0.11
2003/03/12	17:16:50	0.000	0.10
2003/03/12	17:16:55	0.000	0.07
2003/03/12	17:17:00	0.000	0.11
2003/03/12	17:17:05	0.000	0.07
2003/03/12	17:17:10	0.000	0.09
2003/03/12	17:17:15	0.000	0.08
2003/03/12	17:17:20	0.000	0.09
2003/03/12	17:17:25	0.000	0.10
2003/03/12	17:17:30	0.000	0.08
2003/03/12	17:17:35	0.000	0.11
2003/03/12	17:17:40	0.000	0.11

0.09

156(0909)mp(05/03)

0.04

156(0909)mp(05/03)

2003/03/12 17:17:45 0.000 0.10
 2003/03/12 17:17:50 0.000 0.09
 2003/03/12 17:17:55 0.000 0.12
 2003/03/12 17:18:00 0.000 0.11
 2003/03/12 17:18:05 0.000 0.07
 2003/03/12 17:18:10 0.000 0.12
 2003/03/12 17:18:15 0.000 0.08
 2003/03/12 17:18:20 0.000 0.10
 2003/03/12 17:18:25 0.000 0.10
 2003/03/12 17:18:30 0.000 0.08
 2003/03/12 17:18:35 0.000 0.10
 2003/03/12 17:18:40 0.000 0.08
 2003/03/12 17:18:45 0.000 0.10
 2003/03/12 17:18:50 0.000 0.10
 2003/03/12 17:18:55 0.000 0.10
 2003/03/12 17:19:00 0.000 0.12
 2003/03/12 17:19:05 0.000 0.12
 2003/03/12 17:19:10 0.000 0.10
 2003/03/12 17:19:15 0.000 0.06
 2003/03/12 17:19:20 0.000 0.18
 2003/03/12 17:19:25 0.000 0.10
 2003/03/12 17:19:30 0.000 0.09
 2003/03/12 17:19:35 0.000 0.12
 2003/03/12 17:19:40 0.000 0.09
 2003/03/12 17:19:45 0.000 0.11
 2003/03/12 17:19:50 0.000 0.09
 2003/03/12 17:19:55 0.000 0.12
 2003/03/12 17:20:00 0.000 0.12
 2003/03/12 17:20:05 0.000 0.10
 2003/03/12 17:20:10 0.000 0.13
 2003/03/12 17:20:15 0.000 0.14
 2003/03/12 17:20:20 0.000 0.13
 2003/03/12 17:20:25 0.000 0.11
 2003/03/12 17:20:30 0.000 0.16
 2003/03/12 17:20:35 0.000 0.14
 2003/03/12 17:20:40 0.000 0.11
 2003/03/12 17:20:45 0.000 0.15
 2003/03/12 17:20:50 0.000 0.10
 2003/03/12 17:20:55 0.000 0.13
 2003/03/12 17:21:00 0.000 0.13
 2003/03/12 17:21:05 0.000 0.13
 2003/03/12 17:21:10 0.000 0.15
 2003/03/12 17:21:15 0.000 0.12
 2003/03/12 17:21:20 0.000 0.15
 2003/03/12 17:21:25 0.000 0.16
 2003/03/12 17:21:30 0.000 0.16
 2003/03/12 17:21:35 0.000 0.16
 2003/03/12 17:21:40 0.000 0.18
 2003/03/12 17:21:45 0.000 0.18
 2003/03/12 17:21:50 0.000 0.14
 2003/03/12 17:21:55 0.000 0.20
 2003/03/12 17:22:00 0.000 0.16
 2003/03/12 17:22:05 0.000 0.18
 2003/03/12 17:22:10 0.000 0.20
 2003/03/12 17:22:15 0.000 0.19
 2003/03/12 17:22:20 0.000 0.23
 2003/03/12 17:22:25 0.000 0.21
 2003/03/12 17:22:30 0.000 0.25
 2003/03/12 17:22:35 0.000 0.25
 2003/03/12 17:22:40 0.000 0.24
 2003/03/12 17:22:45 0.000 0.27
 2003/03/12 17:22:50 0.000 0.28
 2003/03/12 17:22:55 0.000 0.28
 2003/03/12 17:23:00 0.000 0.23
 2003/03/12 17:23:05 0.000 0.28
 2003/03/12 17:23:10 0.000 0.26
 2003/03/12 17:23:15 0.000 0.24
 2003/03/12 17:23:20 0.000 0.27
 2003/03/12 17:23:25 0.000 0.23
 2003/03/12 17:23:30 0.000 0.26
 2003/03/12 17:23:35 0.000 0.23
 2003/03/12 17:23:40 0.000 0.25
 2003/03/12 17:23:45 0.000 0.25
 2003/03/12 17:23:50 0.000 0.22
 2003/03/12 17:23:55 0.000 0.24
 2003/03/12 17:24:00 0.000 0.25
 2003/03/12 17:24:05 0.000 0.23
 2003/03/12 17:24:10 0.000 0.21
 2003/03/12 17:24:15 0.000 0.25
 2003/03/12 17:24:20 0.000 0.23
 2003/03/12 17:24:25 0.000 0.16
 2003/03/12 17:24:30 0.000 0.23
 2003/03/12 17:24:35 0.000 0.18
 2003/03/12 17:24:40 0.000 0.20
 2003/03/12 17:24:45 0.000 0.20
 2003/03/12 17:24:50 0.000 0.20
 2003/03/12 17:24:55 0.000 0.21
 2003/03/12 17:25:00 0.000 0.18
 2003/03/12 17:25:05 0.000 0.21
 2003/03/12 17:25:10 0.000 0.21
 2003/03/12 17:25:15 0.000 0.20
 2003/03/12 17:25:20 0.000 0.20
 2003/03/12 17:25:25 0.000 0.23
 2003/03/12 17:25:30 0.000 0.22
 2003/03/12 17:25:35 0.000 0.18
 2003/03/12 17:25:40 0.000 0.23
 2003/03/12 17:25:45 0.000 0.19
 2003/03/12 17:25:50 0.000 0.20
 2003/03/12 17:25:55 0.000 0.21
 2003/03/12 17:26:00 0.000 0.20
 2003/03/12 17:26:05 0.000 0.21
 2003/03/12 17:26:10 0.000 0.19
 2003/03/12 17:26:15 0.000 0.22
 2003/03/12 17:26:20 0.000 0.22
 2003/03/12 17:26:25 0.000 0.21
 2003/03/12 17:26:30 0.000 0.24
 2003/03/12 17:26:35 0.000 0.24
 2003/03/12 17:26:40 0.000 0.23
 2003/03/12 17:26:45 0.000 0.20
 2003/03/12 17:26:50 0.000 0.25
 2003/03/12 17:26:55 0.000 0.23
 2003/03/12 17:27:00 0.000 0.22
 2003/03/12 17:27:05 0.000 0.25
 2003/03/12 17:27:10 0.000 0.20
 2003/03/12 17:27:15 0.000 0.22
 2003/03/12 17:27:20 0.000 0.21
 2003/03/12 17:27:25 0.000 0.23
 2003/03/12 17:27:30 0.000 0.24
 2003/03/12 17:27:35 0.000 0.22
 2003/03/12 17:27:40 0.000 0.26
 2003/03/12 17:27:45 0.000 0.26
 2003/03/12 17:27:50 0.000 0.25
 2003/03/12 17:27:55 0.000 0.24
 2003/03/12 17:28:00 0.000 0.28
 2003/03/12 17:28:05 0.000 0.28
 2003/03/12 17:28:10 0.000 0.22
 2003/03/12 17:28:15 0.000 0.28
 2003/03/12 17:28:20 0.000 0.13
 2003/03/12 17:28:25 0.000 0.11
 2003/03/12 17:28:30 0.000 0.07
 2003/03/12 17:28:35 0.000 0.04
 2003/03/12 17:28:40 0.000 0.05
 2003/03/12 17:28:45 0.000 0.00
 2003/03/12 17:28:50 0.000 0.02

0.09

XXXXXXXXXXXXXXXXXXXX

0.19

XXXXXXXXXXXXXXXXXXXX

2003/03/12	17:28:55	0.000	0.01
2003/03/12	17:29:00	0.000	0.02
2003/03/12	17:29:05	0.000	0.06
2003/03/12	17:29:10	0.000	0.11
2003/03/12	17:29:15	0.000	0.09
2003/03/12	17:29:20	0.000	0.05
2003/03/12	17:29:25	0.000	0.08
2003/03/12	17:29:30	0.000	0.03
2003/03/12	17:29:35	0.000	0.03
2003/03/12	17:29:40	0.000	0.03
2003/03/12	17:29:45	0.000	0.01
2003/03/12	17:29:50	0.000	0.02
2003/03/12	17:29:55	0.000	-0.02
2003/03/12	17:30:00	0.000	0.01
2003/03/12	17:30:05	0.000	0.01
2003/03/12	17:30:10	0.000	0.03
2003/03/12	17:30:15	0.000	0.02
2003/03/12	17:30:20	0.000	0.03
2003/03/12	17:30:25	0.000	0.02
2003/03/12	17:30:30	0.000	-0.02
2003/03/12	17:30:35	0.000	0.03
2003/03/12	17:30:40	0.000	0.00
2003/03/12	17:30:45	0.000	-0.01
2003/03/12	17:30:50	0.000	0.02
2003/03/12	17:30:55	0.000	-0.01
2003/03/12	17:31:00	0.000	0.00
2003/03/12	17:31:05	0.000	-0.01
2003/03/12	17:31:10	0.000	0.01
2003/03/12	17:31:15	0.000	0.01
2003/03/12	17:31:20	0.000	-0.01
2003/03/12	17:31:25	0.000	0.02
2003/03/12	17:31:30	0.000	0.04
2003/03/12	17:31:35	0.000	0.04
2003/03/12	17:31:40	0.000	0.03
2003/03/12	17:31:45	0.000	0.08
2003/03/12	17:31:50	0.000	0.07
2003/03/12	17:31:55	0.000	0.04
2003/03/12	17:32:00	0.000	0.06
2003/03/12	17:32:05	0.000	0.06
2003/03/12	17:32:10	0.000	0.07
2003/03/12	17:32:15	0.000	0.07
2003/03/12	17:32:20	0.000	0.07
2003/03/12	17:32:25	0.000	0.09
2003/03/12	17:32:30	0.000	0.07
2003/03/12	17:32:35	0.000	0.10
2003/03/12	17:32:40	0.000	0.10
2003/03/12	17:32:45	0.000	0.10
2003/03/12	17:32:50	0.000	0.10
2003/03/12	17:32:55	0.000	0.12
2003/03/12	17:33:00	0.000	0.11
2003/03/12	17:33:05	0.000	0.07
2003/03/12	17:33:10	0.000	0.12
2003/03/12	17:33:15	0.000	0.08
2003/03/12	17:33:20	0.000	0.09
2003/03/12	17:33:25	0.000	0.10
2003/03/12	17:33:30	0.000	0.08
2003/03/12	17:33:35	0.000	0.08
2003/03/12	17:33:40	0.000	0.07
2003/03/12	17:33:45	0.000	0.10
2003/03/12	17:33:50	0.000	0.10
2003/03/12	17:33:55	0.000	0.08
2003/03/12	17:34:00	0.000	0.12
2003/03/12	17:34:05	0.000	0.12
2003/03/12	17:34:10	0.000	0.10
2003/03/12	17:34:15	0.000	0.08
2003/03/12	17:34:20	0.000	0.13
2003/03/12	17:34:25	0.000	0.10
2003/03/12	17:34:30	0.000	0.09
2003/03/12	17:34:35	0.000	0.12
2003/03/12	17:34:40	0.000	0.08
2003/03/12	17:34:45	0.000	0.11
2003/03/12	17:34:50	0.000	0.09
2003/03/12	17:34:55	0.000	0.11
2003/03/12	17:35:00	0.000	0.11
2003/03/12	17:35:05	0.000	0.09
2003/03/12	17:35:10	0.000	0.13
2003/03/12	17:35:15	0.000	0.13
2003/03/12	17:35:20	0.000	0.11
2003/03/12	17:35:25	0.000	0.10
2003/03/12	17:35:30	0.000	0.14
2003/03/12	17:35:35	0.000	0.13
2003/03/12	17:35:40	0.000	0.10
2003/03/12	17:35:45	0.000	0.14
2003/03/12	17:35:50	0.000	0.09
2003/03/12	17:35:55	0.000	0.12
2003/03/12	17:36:00	0.000	0.12
2003/03/12	17:36:05	0.000	0.12
2003/03/12	17:36:10	0.000	0.14
2003/03/12	17:36:15	0.000	0.11
2003/03/12	17:36:20	0.000	0.13
2003/03/12	17:36:25	0.000	0.13
2003/03/12	17:36:30	0.000	0.13
2003/03/12	17:36:35	0.000	0.13
2003/03/12	17:36:40	0.000	0.16
2003/03/12	17:36:45	0.000	0.14
2003/03/12	17:36:50	0.000	0.11
2003/03/12	17:36:55	0.000	0.18
2003/03/12	17:37:00	0.000	0.12
2003/03/12	17:37:05	0.000	0.13
2003/03/12	17:37:10	0.000	0.16
2003/03/12	17:37:15	0.000	0.13
2003/03/12	17:37:20	0.000	0.15
2003/03/12	17:37:25	0.000	0.12
2003/03/12	17:37:30	0.000	0.15
2003/03/12	17:37:35	0.000	0.15
2003/03/12	17:37:40	0.000	0.14
2003/03/12	17:37:45	0.000	0.17
2003/03/12	17:37:50	0.000	0.18
2003/03/12	17:37:55	0.000	0.17
2003/03/12	17:38:00	0.000	0.14
2003/03/12	17:38:05	0.000	0.19
2003/03/12	17:38:10	0.000	0.18
2003/03/12	17:38:15	0.000	0.15
2003/03/12	17:38:20	0.000	0.18
2003/03/12	17:38:25	0.000	0.15
2003/03/12	17:38:30	0.000	0.17
2003/03/12	17:38:35	0.000	0.16
2003/03/12	17:38:40	0.000	0.17
2003/03/12	17:38:45	0.000	0.19
2003/03/12	17:38:50	0.000	0.18
2003/03/12	17:38:55	0.000	0.18
2003/03/12	17:39:00	0.000	0.19
2003/03/12	17:39:05	0.000	0.19
2003/03/12	17:39:10	0.000	0.17
2003/03/12	17:39:15	0.000	0.21
2003/03/12	17:39:20	0.000	0.19
2003/03/12	17:39:25	0.000	0.18
2003/03/12	17:39:30	0.000	0.20
2003/03/12	17:39:35	0.000	0.18
2003/03/12	17:39:40	0.000	0.18
2003/03/12	17:39:45	0.000	0.18
2003/03/12	17:39:50	0.000	0.18
2003/03/12	17:39:55	0.000	0.20
2003/03/12	17:40:00	0.000	0.17

0.18

2003/03/12 17:28:55

0.08

2003/03/12 17:35:00

0.15

2003/03/12 17:40:00

2003/03/12	17:40:05	0.000	0.20
2003/03/12	17:40:10	0.000	0.20
2003/03/12	17:40:15	0.000	0.18
2003/03/12	17:40:20	0.000	0.18
2003/03/12	17:40:25	0.000	0.22
2003/03/12	17:40:30	0.000	0.21
2003/03/12	17:40:35	0.000	0.17
2003/03/12	17:40:40	0.000	0.22
2003/03/12	17:40:45	0.000	0.18
2003/03/12	17:40:50	0.000	0.18
2003/03/12	17:40:55	0.000	0.21
2003/03/12	17:41:00	0.000	0.19
2003/03/12	17:41:05	0.000	0.20
2003/03/12	17:41:10	0.000	0.18
2003/03/12	17:41:15	0.000	0.21
2003/03/12	17:41:20	0.000	0.20
2003/03/12	17:41:25	0.000	0.20
2003/03/12	17:41:30	0.000	0.22
2003/03/12	17:41:35	0.000	0.23
2003/03/12	17:41:40	0.000	0.22
2003/03/12	17:41:45	0.000	0.18
2003/03/12	17:41:50	0.000	0.25
2003/03/12	17:41:55	0.000	0.22
2003/03/12	17:42:00	0.000	0.24
2003/03/12	17:42:05	0.000	0.24
2003/03/12	17:42:10	0.000	0.21
2003/03/12	17:42:15	0.000	0.24
2003/03/12	17:42:20	0.000	0.22
2003/03/12	17:42:25	0.000	0.24
2003/03/12	17:42:30	0.000	0.25
2003/03/12	17:42:35	0.000	0.23
2003/03/12	17:42:40	0.000	0.25
2003/03/12	17:42:45	0.000	0.26
2003/03/12	17:42:50	0.000	0.25
2003/03/12	17:42:55	0.000	0.24
2003/03/12	17:43:00	0.000	0.28
2003/03/12	17:43:05	0.000	0.28
2003/03/12	17:43:10	0.000	0.23
2003/03/12	17:43:15	0.000	0.28
2003/03/12	17:43:20	0.000	0.23
2003/03/12	17:43:25	0.000	0.28
2003/03/12	17:43:30	0.000	0.28
2003/03/12	17:43:35	0.000	0.25
2003/03/12	17:43:40	0.000	0.27
2003/03/12	17:43:45	0.000	0.23
2003/03/12	17:43:50	0.000	0.26
2003/03/12	17:43:55	0.000	0.27
2003/03/12	17:44:00	0.000	0.26
2003/03/12	17:44:05	0.000	0.27
2003/03/12	17:44:10	0.000	0.29
2003/03/12	17:44:15	0.000	0.27
2003/03/12	17:44:20	0.000	0.25
2003/03/12	17:44:25	0.000	0.29
2003/03/12	17:44:30	0.000	0.28
2003/03/12	17:44:35	0.000	0.27
2003/03/12	17:44:40	0.000	0.28
2003/03/12	17:44:45	0.000	0.28
2003/03/12	17:44:50	0.000	0.28
2003/03/12	17:44:55	0.000	0.28
2003/03/12	17:45:00	0.000	0.28
2003/03/12	17:45:05	0.000	0.29
2003/03/12	17:45:10	0.000	0.27
2003/03/12	17:45:15	0.000	0.28
2003/03/12	17:45:20	0.000	0.30
2003/03/12	17:45:25	0.000	0.29
2003/03/12	17:45:30	0.000	0.28
2003/03/12	17:45:35	0.000	0.30
2003/03/12	17:45:40	0.000	0.23
2003/03/12	17:45:45	0.000	0.18
2003/03/12	17:45:50	0.000	0.14
2003/03/12	17:45:55	0.000	0.08
2003/03/12	17:46:00	0.000	0.05
2003/03/12	17:46:05	0.000	0.02
2003/03/12	17:46:10	0.000	0.03
2003/03/12	17:46:15	0.000	0.03
2003/03/12	17:46:20	0.000	0.00
2003/03/12	17:46:25	0.000	0.01
2003/03/12	17:46:30	0.000	0.02
2003/03/12	17:46:35	0.000	0.02
2003/03/12	17:46:40	0.000	0.05
2003/03/12	17:46:45	0.000	0.14
2003/03/12	17:46:50	0.000	0.18
2003/03/12	17:46:55	0.000	0.18
2003/03/12	17:47:00	0.000	0.26
2003/03/12	17:47:05	0.000	0.23
2003/03/12	17:47:10	0.000	0.25
2003/03/12	17:47:15	0.000	0.25
2003/03/12	17:47:20	0.000	0.24
2003/03/12	17:47:25	0.000	0.21
2003/03/12	17:47:30	0.000	0.14
2003/03/12	17:47:35	0.000	0.12
2003/03/12	17:47:40	0.000	0.08
2003/03/12	17:47:45	0.000	0.05
2003/03/12	17:47:50	0.000	0.03
2003/03/12	17:47:55	0.000	0.05
2003/03/12	17:48:00	0.000	0.03
2003/03/12	17:48:05	0.000	-0.02
2003/03/12	17:48:10	0.000	0.03
2003/03/12	17:48:15	0.000	-0.01
2003/03/12	17:48:20	0.000	0.00
2003/03/12	17:48:25	0.000	0.01
2003/03/12	17:48:30	0.000	-0.01
2003/03/12	17:48:35	0.000	0.00
2003/03/12	17:48:40	0.000	-0.02
2003/03/12	17:48:45	0.000	0.01
2003/03/12	17:48:50	0.000	0.01
2003/03/12	17:48:55	0.000	0.00
2003/03/12	17:49:00	0.000	0.02
2003/03/12	17:49:05	0.000	0.03
2003/03/12	17:49:10	0.000	0.01
2003/03/12	17:49:15	0.000	-0.02
2003/03/12	17:49:20	0.000	0.03
2003/03/12	17:49:25	0.000	0.00
2003/03/12	17:49:30	0.000	-0.01
2003/03/12	17:49:35	0.000	0.02
2003/03/12	17:49:40	0.000	-0.01
2003/03/12	17:49:45	0.000	0.01
2003/03/12	17:49:50	0.000	-0.01
2003/03/12	17:49:55	0.000	0.01
2003/03/12	17:50:00	0.000	0.01
2003/03/12	17:50:05	0.000	-0.01
2003/03/12	17:50:10	0.000	0.02
2003/03/12	17:50:15	0.000	0.02
2003/03/12	17:50:20	0.000	0.01
2003/03/12	17:50:25	0.000	0.01
2003/03/12	17:50:30	0.000	0.05
2003/03/12	17:50:35	0.000	0.03
2003/03/12	17:50:40	0.000	0.01
2003/03/12	17:50:45	0.000	0.06
2003/03/12	17:50:50	0.000	0.02
2003/03/12	17:50:55	0.000	0.05
2003/03/12	17:51:00	0.000	0.05
2003/03/12	17:51:05	0.000	0.05
2003/03/12	17:51:10	0.000	0.08

0.23

17:48:10 PM 03/12/2003

0.09

17:50:20 PM 03/12/2003

2003/03/12	17:51:15	0.000	0.06
2003/03/12	17:51:20	0.000	0.08
2003/03/12	17:51:25	0.000	0.08
2003/03/12	17:51:30	0.000	0.08
2003/03/12	17:51:35	0.000	0.09
2003/03/12	17:51:40	0.000	0.11
2003/03/12	17:51:45	0.000	0.09
2003/03/12	17:51:50	0.000	0.07
2003/03/12	17:51:55	0.000	0.12
2003/03/12	17:52:00	0.000	0.08
2003/03/12	17:52:05	0.000	0.09
2003/03/12	17:52:10	0.000	0.11
2003/03/12	17:52:15	0.000	0.09
2003/03/12	17:52:20	0.000	0.11
2003/03/12	17:52:25	0.000	0.08
2003/03/12	17:52:30	0.000	0.10
2003/03/12	17:52:35	0.000	0.10
2003/03/12	17:52:40	0.000	0.09
2003/03/12	17:52:45	0.000	0.11
2003/03/12	17:52:50	0.000	0.13
2003/03/12	17:52:55	0.000	0.11
2003/03/12	17:53:00	0.000	0.08
2003/03/12	17:53:05	0.000	0.13
2003/03/12	17:53:10	0.000	0.11
2003/03/12	17:53:15	0.000	0.09
2003/03/12	17:53:20	0.000	0.12
2003/03/12	17:53:25	0.000	0.09
2003/03/12	17:53:30	0.000	0.11
2003/03/12	17:53:35	0.000	0.10
2003/03/12	17:53:40	0.000	0.12
2003/03/12	17:53:45	0.000	0.13
2003/03/12	17:53:50	0.000	0.10
2003/03/12	17:53:55	0.000	0.12
2003/03/12	17:54:00	0.000	0.13
2003/03/12	17:54:05	0.000	0.12
2003/03/12	17:54:10	0.000	0.11
2003/03/12	17:54:15	0.000	0.15
2003/03/12	17:54:20	0.000	0.14
2003/03/12	17:54:25	0.000	0.10
2003/03/12	17:54:30	0.000	0.15
2003/03/12	17:54:35	0.000	0.10
2003/03/12	17:54:40	0.000	0.13
2003/03/12	17:54:45	0.000	0.13
2003/03/12	17:54:50	0.000	0.12
2003/03/12	17:54:55	0.000	0.13
2003/03/12	17:55:00	0.000	0.11
2003/03/12	17:55:05	0.000	0.14
2003/03/12	17:55:10	0.000	0.13
2003/03/12	17:55:15	0.000	0.13
2003/03/12	17:55:20	0.000	0.13
2003/03/12	17:55:25	0.000	0.15
2003/03/12	17:55:30	0.000	0.14
2003/03/12	17:55:35	0.000	0.11
2003/03/12	17:55:40	0.000	0.19
2003/03/12	17:55:45	0.000	0.12
2003/03/12	17:55:50	0.000	0.12
2003/03/12	17:55:55	0.000	0.14
2003/03/12	17:56:00	0.000	0.12
2003/03/12	17:56:05	0.000	0.13
2003/03/12	17:56:10	0.000	0.11
2003/03/12	17:56:15	0.000	0.14
2003/03/12	17:56:20	0.000	0.14
2003/03/12	17:56:25	0.000	0.12
2003/03/12	17:56:30	0.000	0.16
2003/03/12	17:56:35	0.000	0.19
2003/03/12	17:56:40	0.000	0.14
2003/03/12	17:56:45	0.000	0.12
2003/03/12	17:56:50	0.000	0.17
2003/03/12	17:56:55	0.000	0.15
2003/03/12	17:57:00	0.000	0.13
2003/03/12	17:57:05	0.000	0.17
2003/03/12	17:57:10	0.000	0.14
2003/03/12	17:57:15	0.000	0.16
2003/03/12	17:57:20	0.000	0.14
2003/03/12	17:57:25	0.000	0.16
2003/03/12	17:57:30	0.000	0.18
2003/03/12	17:57:35	0.000	0.15
2003/03/12	17:57:40	0.000	0.18
2003/03/12	17:57:45	0.000	0.18
2003/03/12	17:57:50	0.000	0.17
2003/03/12	17:57:55	0.000	0.17
2003/03/12	17:58:00	0.000	0.20
2003/03/12	17:58:05	0.000	0.19
2003/03/12	17:58:10	0.000	0.19
2003/03/12	17:58:15	0.000	0.21
2003/03/12	17:58:20	0.000	0.16
2003/03/12	17:58:25	0.000	0.18
2003/03/12	17:58:30	0.000	0.18
2003/03/12	17:58:35	0.000	0.18
2003/03/12	17:58:40	0.000	0.21
2003/03/12	17:58:45	0.000	0.17
2003/03/12	17:58:50	0.000	0.20
2003/03/12	17:58:55	0.000	0.20
2003/03/12	17:59:00	0.000	0.21
2003/03/12	17:59:05	0.000	0.23
2003/03/12	17:59:10	0.000	0.25
2003/03/12	17:59:15	0.000	0.24
2003/03/12	17:59:20	0.000	0.22
2003/03/12	17:59:25	0.000	0.27
2003/03/12	17:59:30	0.000	0.24
2003/03/12	17:59:35	0.000	0.24
2003/03/12	17:59:40	0.000	0.27
2003/03/12	17:59:45	0.000	0.24
2003/03/12	17:59:50	0.000	0.28
2003/03/12	17:59:55	0.000	0.24
2003/03/12	18:00:00	0.000	0.27
2003/03/12	18:00:05	0.000	0.27
2003/03/12	18:00:10	0.000	0.25
2003/03/12	18:00:15	0.000	0.28
2003/03/12	18:00:20	0.000	0.29
2003/03/12	18:00:25	0.000	0.28
2003/03/12	18:00:30	0.000	0.25
2003/03/12	18:00:35	0.000	0.30
2003/03/12	18:00:40	0.000	0.27
2003/03/12	18:00:45	0.000	0.25
2003/03/12	18:00:50	0.000	0.29
2003/03/12	18:00:55	0.000	0.25
2003/03/12	18:01:00	0.000	0.27
2003/03/12	18:01:05	0.000	0.29
2003/03/12	18:01:10	0.000	0.27
2003/03/12	18:01:15	0.000	0.29
2003/03/12	18:01:20	0.000	0.25
2003/03/12	18:01:25	0.000	0.27
2003/03/12	18:01:30	0.000	0.28
2003/03/12	18:01:35	0.000	0.27
2003/03/12	18:01:40	0.000	0.28
2003/03/12	18:01:45	0.000	0.29
2003/03/12	18:01:50	0.000	0.29
2003/03/12	18:01:55	0.000	0.25
2003/03/12	18:02:00	0.000	0.29
2003/03/12	18:02:05	0.000	0.24
2003/03/12	18:02:10	0.000	0.28
2003/03/12	18:02:15	0.000	0.26
2003/03/12	18:02:20	0.000	0.26

0.09

XXXXXXXXXXXXXXXXXXXX

0.17

XXXXXXXXXXXXXXXXXXXX

2003/03/12	18:02:25	0.000	0.27
2003/03/12	18:02:30	0.000	0.26
2003/03/12	18:02:35	0.000	0.26
2003/03/12	18:02:40	0.000	0.27
2003/03/12	18:02:45	0.000	0.26
2003/03/12	18:02:50	0.000	0.27
2003/03/12	18:02:55	0.000	0.29
2003/03/12	18:03:00	0.000	0.26
2003/03/12	18:03:05	0.000	0.25
2003/03/12	18:03:10	0.000	0.30
2003/03/12	18:03:15	0.000	0.27
2003/03/12	18:03:20	0.000	0.29
2003/03/12	18:03:25	0.000	0.28
2003/03/12	18:03:30	0.000	0.26
2003/03/12	18:03:35	0.000	0.27
2003/03/12	18:03:40	0.000	0.25
2003/03/12	18:03:45	0.000	0.28
2003/03/12	18:03:50	0.000	0.29
2003/03/12	18:03:55	0.000	0.26
2003/03/12	18:04:00	0.000	0.30
2003/03/12	18:04:05	0.000	0.30
2003/03/12	18:04:10	0.000	0.29
2003/03/12	18:04:15	0.000	0.27
2003/03/12	18:04:20	0.000	0.32
2003/03/12	18:04:25	0.000	0.30
2003/03/12	18:04:30	0.000	0.29
2003/03/12	18:04:35	0.000	0.31
2003/03/12	18:04:40	0.000	0.25
2003/03/12	18:04:45	0.000	0.23
2003/03/12	18:04:50	0.000	0.18
2003/03/12	18:04:55	0.000	0.12
2003/03/12	18:05:00	0.000	0.08
2003/03/12	18:05:05	0.000	0.03
2003/03/12	18:05:10	0.000	0.05
2003/03/12	18:05:15	0.000	0.03
2003/03/12	18:05:20	0.000	0.02
2003/03/12	18:05:25	0.000	0.01
2003/03/12	18:05:30	0.000	0.06
2003/03/12	18:05:35	0.000	0.10
2003/03/12	18:05:40	0.000	0.10
2003/03/12	18:05:45	0.000	0.15
2003/03/12	18:05:50	0.000	0.08
2003/03/12	18:05:55	0.000	0.05
2003/03/12	18:06:00	0.000	0.04
2003/03/12	18:06:05	0.000	0.02
2003/03/12	18:06:10	0.000	0.03
2003/03/12	18:06:15	0.000	-0.02
2003/03/12	18:06:20	0.000	0.01
2003/03/12	18:06:25	0.000	0.00
2003/03/12	18:06:30	0.000	0.00
2003/03/12	18:06:35	0.000	0.02
2003/03/12	18:06:40	0.000	0.03
2003/03/12	18:06:45	0.000	0.01
2003/03/12	18:06:50	0.000	-0.02
2003/03/12	18:06:55	0.000	0.03
2003/03/12	18:07:00	0.000	0.00
2003/03/12	18:07:05	0.000	-0.01
2003/03/12	18:07:10	0.000	0.02
2003/03/12	18:07:15	0.000	-0.01
2003/03/12	18:07:20	0.000	0.01
2003/03/12	18:07:25	0.000	-0.01
2003/03/12	18:07:30	0.000	0.01
2003/03/12	18:07:35	0.000	0.01
2003/03/12	18:07:40	0.000	-0.01
2003/03/12	18:07:45	0.000	0.01
2003/03/12	18:07:50	0.000	0.02
2003/03/12	18:07:55	0.000	0.03
2003/03/12	18:08:00	0.000	0.01
2003/03/12	18:08:05	0.000	0.06
2003/03/12	18:08:10	0.000	0.04
2003/03/12	18:08:15	0.000	0.02
2003/03/12	18:08:20	0.000	0.07
2003/03/12	18:08:25	0.000	0.03
2003/03/12	18:08:30	0.000	0.06
2003/03/12	18:08:35	0.000	0.06
2003/03/12	18:08:40	0.000	0.07
2003/03/12	18:08:45	0.000	0.09
2003/03/12	18:08:50	0.000	0.06
2003/03/12	18:08:55	0.000	0.09
2003/03/12	18:09:00	0.000	0.09
2003/03/12	18:09:05	0.000	0.09
2003/03/12	18:09:10	0.000	0.09
2003/03/12	18:09:15	0.000	0.12
2003/03/12	18:09:20	0.000	0.11
2003/03/12	18:09:25	0.000	0.07
2003/03/12	18:09:30	0.000	0.12
2003/03/12	18:09:35	0.000	0.08
2003/03/12	18:09:40	0.000	0.09
2003/03/12	18:09:45	0.000	0.10
2003/03/12	18:09:50	0.000	0.09
2003/03/12	18:09:55	0.000	0.10
2003/03/12	18:10:00	0.000	0.08
2003/03/12	18:10:05	0.000	0.11
2003/03/12	18:10:10	0.000	0.10
2003/03/12	18:10:15	0.000	0.09
2003/03/12	18:10:20	0.000	0.10
2003/03/12	18:10:25	0.000	0.12
2003/03/12	18:10:30	0.000	0.11
2003/03/12	18:10:35	0.000	0.08
2003/03/12	18:10:40	0.000	0.13
2003/03/12	18:10:45	0.000	0.10
2003/03/12	18:10:50	0.000	0.09
2003/03/12	18:10:55	0.000	0.12
2003/03/12	18:11:00	0.000	0.09
2003/03/12	18:11:05	0.000	0.10
2003/03/12	18:11:10	0.000	0.09
2003/03/12	18:11:15	0.000	0.11
2003/03/12	18:11:20	0.000	0.12
2003/03/12	18:11:25	0.000	0.10
2003/03/12	18:11:30	0.000	0.14
2003/03/12	18:11:35	0.000	0.13
2003/03/12	18:11:40	0.000	0.12
2003/03/12	18:11:45	0.000	0.11
2003/03/12	18:11:50	0.000	0.16
2003/03/12	18:11:55	0.000	0.14
2003/03/12	18:12:00	0.000	0.10
2003/03/12	18:12:05	0.000	0.15
2003/03/12	18:12:10	0.000	0.11
2003/03/12	18:12:15	0.000	0.13
2003/03/12	18:12:20	0.000	0.13
2003/03/12	18:12:25	0.000	0.12
2003/03/12	18:12:30	0.000	0.13
2003/03/12	18:12:35	0.000	0.11
2003/03/12	18:12:40	0.000	0.14
2003/03/12	18:12:45	0.000	0.14
2003/03/12	18:12:50	0.000	0.14
2003/03/12	18:12:55	0.000	0.16
2003/03/12	18:13:00	0.000	0.17
2003/03/12	18:13:05	0.000	0.16
2003/03/12	18:13:10	0.000	0.13
2003/03/12	18:13:15	0.000	0.16
2003/03/12	18:13:20	0.000	0.13
2003/03/12	18:13:25	0.000	0.14
2003/03/12	18:13:30	0.000	0.16

0.27

20030312 180225

0.05

20030312 181000

2003/03/12	18:13:36	0.000	0.14
2003/03/12	18:13:40	0.000	0.17
2003/03/12	18:13:46	0.000	0.14
2003/03/12	18:13:50	0.000	0.17
2003/03/12	18:13:55	0.000	0.17
2003/03/12	18:14:00	0.000	0.16
2003/03/12	18:14:05	0.000	0.19
2003/03/12	18:14:10	0.000	0.20
2003/03/12	18:14:15	0.000	0.18
2003/03/12	18:14:20	0.000	0.19
2003/03/12	18:14:25	0.000	0.21
2003/03/12	18:14:30	0.000	0.16
2003/03/12	18:14:35	0.000	0.17
2003/03/12	18:14:40	0.000	0.21
2003/03/12	18:14:45	0.000	0.17
2003/03/12	18:14:50	0.000	0.19
2003/03/12	18:14:55	0.000	0.18
2003/03/12	18:15:00	0.000	0.20
2003/03/12	18:15:05	0.000	0.21
2003/03/12	18:15:10	0.000	0.16
2003/03/12	18:15:15	0.000	0.21
2003/03/12	18:15:20	0.000	0.21
2003/03/12	18:15:25	0.000	0.21
2003/03/12	18:15:30	0.000	0.20
2003/03/12	18:15:35	0.000	0.24
2003/03/12	18:15:40	0.000	0.22
2003/03/12	18:15:45	0.000	0.20
2003/03/12	18:15:50	0.000	0.25
2003/03/12	18:15:55	0.000	0.20
2003/03/12	18:16:00	0.000	0.22
2003/03/12	18:16:05	0.000	0.23
2003/03/12	18:16:10	0.000	0.22
2003/03/12	18:16:15	0.000	0.24
2003/03/12	18:16:20	0.000	0.21
2003/03/12	18:16:25	0.000	0.24
2003/03/12	18:16:30	0.000	0.24
2003/03/12	18:16:35	0.000	0.24
2003/03/12	18:16:40	0.000	0.24
2003/03/12	18:16:45	0.000	0.26
2003/03/12	18:16:50	0.000	0.26
2003/03/12	18:16:55	0.000	0.23
2003/03/12	18:17:00	0.000	0.28
2003/03/12	18:17:05	0.000	0.24
2003/03/12	18:17:10	0.000	0.25
2003/03/12	18:17:15	0.000	0.27
2003/03/12	18:17:20	0.000	0.26
2003/03/12	18:17:25	0.000	0.27
2003/03/12	18:17:30	0.000	0.25
2003/03/12	18:17:35	0.000	0.28
2003/03/12	18:17:40	0.000	0.27
2003/03/12	18:17:45	0.000	0.26
2003/03/12	18:17:50	0.000	0.28
2003/03/12	18:17:55	0.000	0.30
2003/03/12	18:18:00	0.000	0.28
2003/03/12	18:18:05	0.000	0.28
2003/03/12	18:18:10	0.000	0.31
2003/03/12	18:18:15	0.000	0.28
2003/03/12	18:18:20	0.000	0.27
2003/03/12	18:18:25	0.000	0.30
2003/03/12	18:18:30	0.000	0.26
2003/03/12	18:18:35	0.000	0.29
2003/03/12	18:18:40	0.000	0.27
2003/03/12	18:18:45	0.000	0.26
2003/03/12	18:18:50	0.000	0.30
2003/03/12	18:18:55	0.000	0.28
2003/03/12	18:19:00	0.000	0.31
2003/03/12	18:19:05	0.000	0.31
2003/03/12	18:19:10	0.000	0.30
2003/03/12	18:19:15	0.000	0.29
2003/03/12	18:19:20	0.000	0.32
2003/03/12	18:19:25	0.000	0.32
2003/03/12	18:19:30	0.000	0.28
2003/03/12	18:19:35	0.000	0.34
2003/03/12	18:19:40	0.000	0.29
2003/03/12	18:19:45	0.000	0.31
2003/03/12	18:19:50	0.000	0.31
2003/03/12	18:19:55	0.000	0.31
2003/03/12	18:20:00	0.000	0.32
2003/03/12	18:20:05	0.000	0.30
2003/03/12	18:20:10	0.000	0.33
2003/03/12	18:20:15	0.000	0.32
2003/03/12	18:20:20	0.000	0.32
2003/03/12	18:20:25	0.000	0.34
2003/03/12	18:20:30	0.000	0.35
2003/03/12	18:20:35	0.000	0.33
2003/03/12	18:20:40	0.000	0.30
2003/03/12	18:20:45	0.000	0.35
2003/03/12	18:20:50	0.000	0.31
2003/03/12	18:20:55	0.000	0.31
2003/03/12	18:21:00	0.000	0.34
2003/03/12	18:21:05	0.000	0.32
2003/03/12	18:21:10	0.000	0.34
2003/03/12	18:21:15	0.000	0.31
2003/03/12	18:21:20	0.000	0.34
2003/03/12	18:21:25	0.000	0.34
2003/03/12	18:21:30	0.000	0.32
2003/03/12	18:21:35	0.000	0.35
2003/03/12	18:21:40	0.000	0.35
2003/03/12	18:21:45	0.000	0.33
2003/03/12	18:21:50	0.000	0.31
2003/03/12	18:21:55	0.000	0.35
2003/03/12	18:22:00	0.000	0.30
2003/03/12	18:22:05	0.000	0.21
2003/03/12	18:22:10	0.000	0.19
2003/03/12	18:22:15	0.000	0.10
2003/03/12	18:22:20	0.000	0.08
2003/03/12	18:22:25	0.000	0.04
2003/03/12	18:22:30	0.000	0.03
2003/03/12	18:22:35	0.000	0.04
2003/03/12	18:22:40	0.000	-0.01
2003/03/12	18:22:45	0.000	0.01
2003/03/12	18:22:50	0.000	0.01
2003/03/12	18:22:55	0.000	0.01
2003/03/12	18:23:00	0.000	0.03
2003/03/12	18:23:05	0.000	0.12
2003/03/12	18:23:10	0.000	0.17
2003/03/12	18:23:15	0.000	0.19
2003/03/12	18:23:20	0.000	0.28
2003/03/12	18:23:25	0.000	0.25
2003/03/12	18:23:30	0.000	0.27
2003/03/12	18:23:35	0.000	0.28
2003/03/12	18:23:40	0.000	0.27
2003/03/12	18:23:45	0.000	0.29
2003/03/12	18:23:50	0.000	0.24
2003/03/12	18:23:55	0.000	0.21
2003/03/12	18:24:00	0.000	0.15
2003/03/12	18:24:05	0.000	0.10
2003/03/12	18:24:10	0.000	0.08
2003/03/12	18:24:15	0.000	0.06
2003/03/12	18:24:20	0.000	0.04
2003/03/12	18:24:25	0.000	0.00
2003/03/12	18:24:30	0.000	0.04
2003/03/12	18:24:35	0.000	0.00
2003/03/12	18:24:40	0.000	-0.01

0.14

18:05:27:01 mo18:05:27:01

0.26

18:07:41:01 mo18:07:41:01

2003/03/12	18:24:45	0.000	0.02
2003/03/12	18:24:50	0.000	-0.01
2003/03/12	18:24:55	0.000	0.00
2003/03/12	18:25:00	0.000	-0.01
2003/03/12	18:25:05	0.000	0.01
2003/03/12	18:25:10	0.000	0.04
2003/03/12	18:25:15	0.000	-0.01
2003/03/12	18:25:20	0.000	0.01
2003/03/12	18:25:25	0.000	0.02
2003/03/12	18:25:30	0.000	0.01
2003/03/12	18:25:35	0.000	-0.01
2003/03/12	18:25:40	0.000	0.03
2003/03/12	18:25:45	0.000	0.02
2003/03/12	18:25:50	0.000	-0.01
2003/03/12	18:25:55	0.000	0.03
2003/03/12	18:26:00	0.000	-0.02
2003/03/12	18:26:05	0.000	0.00
2003/03/12	18:26:10	0.000	0.00
2003/03/12	18:26:15	0.000	0.00
2003/03/12	18:26:20	0.000	0.01
2003/03/12	18:26:25	0.000	-0.01
2003/03/12	18:26:30	0.000	0.02
2003/03/12	18:26:35	0.000	0.01
2003/03/12	18:26:40	0.000	0.02
2003/03/12	18:26:45	0.000	0.03
2003/03/12	18:26:50	0.000	0.08
2003/03/12	18:26:55	0.000	0.05
2003/03/12	18:27:00	0.000	0.02
2003/03/12	18:27:05	0.000	0.08
2003/03/12	18:27:10	0.000	0.04
2003/03/12	18:27:15	0.000	0.08
2003/03/12	18:27:20	0.000	0.07
2003/03/12	18:27:25	0.000	0.08
2003/03/12	18:27:30	0.000	0.07
2003/03/12	18:27:35	0.000	0.06
2003/03/12	18:27:40	0.000	0.09
2003/03/12	18:27:45	0.000	0.09
2003/03/12	18:27:50	0.000	0.09
2003/03/12	18:27:55	0.000	0.12
2003/03/12	18:28:00	0.000	0.12
2003/03/12	18:28:05	0.000	0.10
2003/03/12	18:28:10	0.000	0.08
2003/03/12	18:28:15	0.000	0.13
2003/03/12	18:28:20	0.000	0.10
2003/03/12	18:28:25	0.000	0.09
2003/03/12	18:28:30	0.000	0.12
2003/03/12	18:28:35	0.000	0.09
2003/03/12	18:28:40	0.000	0.12
2003/03/12	18:28:45	0.000	0.10
2003/03/12	18:28:50	0.000	0.12
2003/03/12	18:28:55	0.000	0.12
2003/03/12	18:29:00	0.000	0.10
2003/03/12	18:29:05	0.000	0.14
2003/03/12	18:29:10	0.000	0.14
2003/03/12	18:29:15	0.000	0.12
2003/03/12	18:29:20	0.000	0.11
2003/03/12	18:29:25	0.000	0.15
2003/03/12	18:29:30	0.000	0.13
2003/03/12	18:29:35	0.000	0.10
2003/03/12	18:29:40	0.000	0.15
2003/03/12	18:29:45	0.000	0.11
2003/03/12	18:29:50	0.000	0.13
2003/03/12	18:29:55	0.000	0.13
2003/03/12	18:30:00	0.000	0.15
2003/03/12	18:30:05	0.000	0.15
2003/03/12	18:30:10	0.000	0.12
2003/03/12	18:30:15	0.000	0.15
2003/03/12	18:30:20	0.000	0.15
2003/03/12	18:30:25	0.000	0.15
2003/03/12	18:30:30	0.000	0.15
2003/03/12	18:30:35	0.000	0.17
2003/03/12	18:30:40	0.000	0.15
2003/03/12	18:30:45	0.000	0.13
2003/03/12	18:30:50	0.000	0.19
2003/03/12	18:30:55	0.000	0.14
2003/03/12	18:31:00	0.000	0.15
2003/03/12	18:31:05	0.000	0.17
2003/03/12	18:31:10	0.000	0.15
2003/03/12	18:31:15	0.000	0.17
2003/03/12	18:31:20	0.000	0.15
2003/03/12	18:31:25	0.000	0.18
2003/03/12	18:31:30	0.000	0.18
2003/03/12	18:31:35	0.000	0.17
2003/03/12	18:31:40	0.000	0.19
2003/03/12	18:31:45	0.000	0.20
2003/03/12	18:31:50	0.000	0.19
2003/03/12	18:31:55	0.000	0.18
2003/03/12	18:32:00	0.000	0.21
2003/03/12	18:32:05	0.000	0.16
2003/03/12	18:32:10	0.000	0.17
2003/03/12	18:32:15	0.000	0.21
2003/03/12	18:32:20	0.000	0.17
2003/03/12	18:32:25	0.000	0.19
2003/03/12	18:32:30	0.000	0.18
2003/03/12	18:32:35	0.000	0.20
2003/03/12	18:32:40	0.000	0.21
2003/03/12	18:32:45	0.000	0.18
2003/03/12	18:32:50	0.000	0.21
2003/03/12	18:32:55	0.000	0.22
2003/03/12	18:33:00	0.000	0.21
2003/03/12	18:33:05	0.000	0.20
2003/03/12	18:33:10	0.000	0.25
2003/03/12	18:33:15	0.000	0.24
2003/03/12	18:33:20	0.000	0.21
2003/03/12	18:33:25	0.000	0.25
2003/03/12	18:33:30	0.000	0.21
2003/03/12	18:33:35	0.000	0.23
2003/03/12	18:33:40	0.000	0.24
2003/03/12	18:33:45	0.000	0.23
2003/03/12	18:33:50	0.000	0.25
2003/03/12	18:33:55	0.000	0.23
2003/03/12	18:34:00	0.000	0.26
2003/03/12	18:34:05	0.000	0.25
2003/03/12	18:34:10	0.000	0.25
2003/03/12	18:34:15	0.000	0.25
2003/03/12	18:34:20	0.000	0.28
2003/03/12	18:34:25	0.000	0.27
2003/03/12	18:34:30	0.000	0.29
2003/03/12	18:34:35	0.000	0.29
2003/03/12	18:34:40	0.000	0.25
2003/03/12	18:34:45	0.000	0.25
2003/03/12	18:34:50	0.000	0.27
2003/03/12	18:34:55	0.000	0.24
2003/03/12	18:35:00	0.000	0.26
2003/03/12	18:35:05	0.000	0.24
2003/03/12	18:35:10	0.000	0.26
2003/03/12	18:35:15	0.000	0.26
2003/03/12	18:35:20	0.000	0.24
2003/03/12	18:35:25	0.000	0.27
2003/03/12	18:35:30	0.000	0.27
2003/03/12	18:35:35	0.000	0.26
2003/03/12	18:35:40	0.000	0.24
2003/03/12	18:35:45	0.000	0.25
2003/03/12	18:35:50	0.000	0.25

0.20

18:24:45 thru 18:35:50

0.07

18:29:50 thru 18:30:00

0.20

18:34:55 thru 18:35:50

2003/03/12	18:35:55	0.000	0.24
2003/03/12	18:36:00	0.000	0.28
2003/03/12	18:36:05	0.000	0.24
2003/03/12	18:36:10	0.000	0.27
2003/03/12	18:36:15	0.000	0.28
2003/03/12	18:36:20	0.000	0.27
2003/03/12	18:36:25	0.000	0.27
2003/03/12	18:36:30	0.000	0.26
2003/03/12	18:36:35	0.000	0.29
2003/03/12	18:36:40	0.000	0.28
2003/03/12	18:36:45	0.000	0.28
2003/03/12	18:36:50	0.000	0.27
2003/03/12	18:36:55	0.000	0.30
2003/03/12	18:37:00	0.000	0.29
2003/03/12	18:37:05	0.000	0.25
2003/03/12	18:37:10	0.000	0.30
2003/03/12	18:37:15	0.000	0.28
2003/03/12	18:37:20	0.000	0.27
2003/03/12	18:37:25	0.000	0.28
2003/03/12	18:37:30	0.000	0.27
2003/03/12	18:37:35	0.000	0.29
2003/03/12	18:37:40	0.000	0.25
2003/03/12	18:37:45	0.000	0.28
2003/03/12	18:37:50	0.000	0.28
2003/03/12	18:37:55	0.000	0.27
2003/03/12	18:38:00	0.000	0.28
2003/03/12	18:38:05	0.000	0.30
2003/03/12	18:38:10	0.000	0.28
2003/03/12	18:38:15	0.000	0.25
2003/03/12	18:38:20	0.000	0.30
2003/03/12	18:38:25	0.000	0.28
2003/03/12	18:38:30	0.000	0.28
2003/03/12	18:38:35	0.000	0.29
2003/03/12	18:38:40	0.000	0.25
2003/03/12	18:38:45	0.000	0.28
2003/03/12	18:38:50	0.000	0.25
2003/03/12	18:38:55	0.000	0.28
2003/03/12	18:39:00	0.000	0.28
2003/03/12	18:39:05	0.000	0.28
2003/03/12	18:39:10	0.000	0.29
2003/03/12	18:39:15	0.000	0.30
2003/03/12	18:39:20	0.000	0.28
2003/03/12	18:39:25	0.000	0.28
2003/03/12	18:39:30	0.000	0.31
2003/03/12	18:39:35	0.000	0.28
2003/03/12	18:39:40	0.000	0.28
2003/03/12	18:39:45	0.000	0.30
2003/03/12	18:39:50	0.000	0.28
2003/03/12	18:39:55	0.000	0.29
2003/03/12	18:40:00	0.000	0.28
2003/03/12	18:40:05	0.000	0.29
2003/03/12	18:40:10	0.000	0.30
2003/03/12	18:40:15	0.000	0.27
2003/03/12	18:40:20	0.000	0.30
2003/03/12	18:40:25	0.000	0.31
2003/03/12	18:40:30	0.000	0.31
2003/03/12	18:40:35	0.000	0.31
2003/03/12	18:40:40	0.000	0.34
2003/03/12	18:40:45	0.000	0.34
2003/03/12	18:40:50	0.000	0.30
2003/03/12	18:40:55	0.000	0.35
2003/03/12	18:41:00	0.000	0.31
2003/03/12	18:41:05	0.000	0.31
2003/03/12	18:41:10	0.000	0.29
2003/03/12	18:41:15	0.000	0.22
2003/03/12	18:41:20	0.000	0.17
2003/03/12	18:41:25	0.000	0.10
2003/03/12	18:41:30	0.000	0.08
2003/03/12	18:41:35	0.000	0.06
2003/03/12	18:41:40	0.000	0.03
2003/03/12	18:41:45	0.000	0.03
2003/03/12	18:41:50	0.000	0.04
2003/03/12	18:41:55	0.000	0.03
2003/03/12	18:42:00	0.000	0.04
2003/03/12	18:42:05	0.000	0.14
2003/03/12	18:42:10	0.000	0.12
2003/03/12	18:42:15	0.000	0.08
2003/03/12	18:42:20	0.000	0.09
2003/03/12	18:42:25	0.000	0.03
2003/03/12	18:42:30	0.000	0.03
2003/03/12	18:42:35	0.000	0.00
2003/03/12	18:42:40	0.000	0.02
2003/03/12	18:42:45	0.000	0.01
2003/03/12	18:42:50	0.000	-0.01
2003/03/12	18:42:55	0.000	0.02
2003/03/12	18:43:00	0.000	0.02
2003/03/12	18:43:05	0.000	0.01
2003/03/12	18:43:10	0.000	-0.01
2003/03/12	18:43:15	0.000	0.03
2003/03/12	18:43:20	0.000	0.02
2003/03/12	18:43:25	0.000	-0.01
2003/03/12	18:43:30	0.000	0.03
2003/03/12	18:43:35	0.000	-0.02
2003/03/12	18:43:40	0.000	0.01
2003/03/12	18:43:45	0.000	0.00
2003/03/12	18:43:50	0.000	0.00
2003/03/12	18:43:55	0.000	0.01
2003/03/12	18:44:00	0.000	-0.01
2003/03/12	18:44:05	0.000	0.02
2003/03/12	18:44:10	0.000	0.02
2003/03/12	18:44:15	0.000	0.03
2003/03/12	18:44:20	0.000	0.04
2003/03/12	18:44:25	0.000	0.08
2003/03/12	18:44:30	0.000	0.05
2003/03/12	18:44:35	0.000	0.03
2003/03/12	18:44:40	0.000	0.05
2003/03/12	18:44:45	0.000	0.04
2003/03/12	18:44:50	0.000	0.06
2003/03/12	18:44:55	0.000	0.08
2003/03/12	18:45:00	0.000	0.06
2003/03/12	18:45:05	0.000	0.08
2003/03/12	18:45:10	0.000	0.05
2003/03/12	18:45:15	0.000	0.08
2003/03/12	18:45:20	0.000	0.08
2003/03/12	18:45:25	0.000	0.07
2003/03/12	18:45:30	0.000	0.10
2003/03/12	18:45:35	0.000	0.10
2003/03/12	18:45:40	0.000	0.08
2003/03/12	18:45:45	0.000	0.08
2003/03/12	18:45:50	0.000	0.11
2003/03/12	18:45:55	0.000	0.08
2003/03/12	18:46:00	0.000	0.07
2003/03/12	18:46:05	0.000	0.10
2003/03/12	18:46:10	0.000	0.06
2003/03/12	18:46:15	0.000	0.08
2003/03/12	18:46:20	0.000	0.08
2003/03/12	18:46:25	0.000	0.08
2003/03/12	18:46:30	0.000	0.09
2003/03/12	18:46:35	0.000	0.08
2003/03/12	18:46:40	0.000	0.09
2003/03/12	18:46:45	0.000	0.10
2003/03/12	18:46:50	0.000	0.09
2003/03/12	18:46:55	0.000	0.07
2003/03/12	18:47:00	0.000	0.11

0.27

0.27

0.11

0.11

2003/03/12	18:47:05	0.000	0.09
2003/03/12	18:47:10	0.000	0.08
2003/03/12	18:47:15	0.000	0.11
2003/03/12	18:47:20	0.000	0.06
2003/03/12	18:47:25	0.000	0.09
2003/03/12	18:47:30	0.000	0.08
2003/03/12	18:47:35	0.000	0.09
2003/03/12	18:47:40	0.000	0.11
2003/03/12	18:47:45	0.000	0.07
2003/03/12	18:47:50	0.000	0.10
2003/03/12	18:47:55	0.000	0.10
2003/03/12	18:48:00	0.000	0.10
2003/03/12	18:48:05	0.000	0.10
2003/03/12	18:48:10	0.000	0.13
2003/03/12	18:48:15	0.000	0.12
2003/03/12	18:48:20	0.000	0.09
2003/03/12	18:48:25	0.000	0.14
2003/03/12	18:48:30	0.000	0.10
2003/03/12	18:48:35	0.000	0.11
2003/03/12	18:48:40	0.000	0.13
2003/03/12	18:48:45	0.000	0.11
2003/03/12	18:48:50	0.000	0.13
2003/03/12	18:48:55	0.000	0.11
2003/03/12	18:49:00	0.000	0.14
2003/03/12	18:49:05	0.000	0.14
2003/03/12	18:49:10	0.000	0.12
2003/03/12	18:49:15	0.000	0.14
2003/03/12	18:49:20	0.000	0.16
2003/03/12	18:49:25	0.000	0.15
2003/03/12	18:49:30	0.000	0.12
2003/03/12	18:49:35	0.000	0.17
2003/03/12	18:49:40	0.000	0.15
2003/03/12	18:49:45	0.000	0.13
2003/03/12	18:49:50	0.000	0.17
2003/03/12	18:49:55	0.000	0.14
2003/03/12	18:50:00	0.000	0.16
2003/03/12	18:50:05	0.000	0.14
2003/03/12	18:50:10	0.000	0.17
2003/03/12	18:50:15	0.000	0.17
2003/03/12	18:50:20	0.000	0.15
2003/03/12	18:50:25	0.000	0.19
2003/03/12	18:50:30	0.000	0.19
2003/03/12	18:50:35	0.000	0.18
2003/03/12	18:50:40	0.000	0.17
2003/03/12	18:50:45	0.000	0.21
2003/03/12	18:50:50	0.000	0.20
2003/03/12	18:50:55	0.000	0.17
2003/03/12	18:51:00	0.000	0.22
2003/03/12	18:51:05	0.000	0.18
2003/03/12	18:51:10	0.000	0.20
2003/03/12	18:51:15	0.000	0.20
2003/03/12	18:51:20	0.000	0.20
2003/03/12	18:51:25	0.000	0.21
2003/03/12	18:51:30	0.000	0.20
2003/03/12	18:51:35	0.000	0.24
2003/03/12	18:51:40	0.000	0.23
2003/03/12	18:51:45	0.000	0.24
2003/03/12	18:51:50	0.000	0.24
2003/03/12	18:51:55	0.000	0.26
2003/03/12	18:52:00	0.000	0.25
2003/03/12	18:52:05	0.000	0.22
2003/03/12	18:52:10	0.000	0.27
2003/03/12	18:52:15	0.000	0.24
2003/03/12	18:52:20	0.000	0.24
2003/03/12	18:52:25	0.000	0.26
2003/03/12	18:52:30	0.000	0.24
2003/03/12	18:52:35	0.000	0.26
2003/03/12	18:52:40	0.000	0.23
2003/03/12	18:52:45	0.000	0.26
2003/03/12	18:52:50	0.000	0.26
2003/03/12	18:52:55	0.000	0.25
2003/03/12	18:53:00	0.000	0.27
2003/03/12	18:53:05	0.000	0.26
2003/03/12	18:53:10	0.000	0.26
2003/03/12	18:53:15	0.000	0.26
2003/03/12	18:53:20	0.000	0.29
2003/03/12	18:53:25	0.000	0.29
2003/03/12	18:53:30	0.000	0.25
2003/03/12	18:53:35	0.000	0.29
2003/03/12	18:53:40	0.000	0.25
2003/03/12	18:53:45	0.000	0.27
2003/03/12	18:53:50	0.000	0.25
2003/03/12	18:53:55	0.000	0.27
2003/03/12	18:54:00	0.000	0.26
2003/03/12	18:54:05	0.000	0.26
2003/03/12	18:54:10	0.000	0.26
2003/03/12	18:54:15	0.000	0.29
2003/03/12	18:54:20	0.000	0.26
2003/03/12	18:54:25	0.000	0.27
2003/03/12	18:54:30	0.000	0.30
2003/03/12	18:54:35	0.000	0.28
2003/03/12	18:54:40	0.000	0.26
2003/03/12	18:54:45	0.000	0.30
2003/03/12	18:54:50	0.000	0.26
2003/03/12	18:54:55	0.000	0.26
2003/03/12	18:55:00	0.000	0.26
2003/03/12	18:55:05	0.000	0.27
2003/03/12	18:55:10	0.000	0.29
2003/03/12	18:55:15	0.000	0.26
2003/03/12	18:55:20	0.000	0.29
2003/03/12	18:55:25	0.000	0.29
2003/03/12	18:55:30	0.000	0.29
2003/03/12	18:55:35	0.000	0.31
2003/03/12	18:55:40	0.000	0.31
2003/03/12	18:55:45	0.000	0.27
2003/03/12	18:55:50	0.000	0.32
2003/03/12	18:55:55	0.000	0.28
2003/03/12	18:56:00	0.000	0.29
2003/03/12	18:56:05	0.000	0.29
2003/03/12	18:56:10	0.000	0.30
2003/03/12	18:56:15	0.000	0.28
2003/03/12	18:56:20	0.000	0.30
2003/03/12	18:56:25	0.000	0.28
2003/03/12	18:56:30	0.000	0.31
2003/03/12	18:56:35	0.000	0.30
2003/03/12	18:56:40	0.000	0.29
2003/03/12	18:56:45	0.000	0.31
2003/03/12	18:56:50	0.000	0.33
2003/03/12	18:56:55	0.000	0.31
2003/03/12	18:57:00	0.000	0.29
2003/03/12	18:57:05	0.000	0.34
2003/03/12	18:57:10	0.000	0.32
2003/03/12	18:57:15	0.000	0.30
2003/03/12	18:57:20	0.000	0.33
2003/03/12	18:57:25	0.000	0.30
2003/03/12	18:57:30	0.000	0.32
2003/03/12	18:57:35	0.000	0.31
2003/03/12	18:57:40	0.000	0.32
2003/03/12	18:57:45	0.000	0.33
2003/03/12	18:57:50	0.000	0.31
2003/03/12	18:57:55	0.000	0.35
2003/03/12	18:58:00	0.000	0.34
2003/03/12	18:58:05	0.000	0.33
2003/03/12	18:58:10	0.000	0.31

0.10

2003/03/12 18:50:00

0.24

2003/03/12 18:54:00

2003/03/12	18:58:15	0.000	0.36
2003/03/12	18:58:20	0.000	0.34
2003/03/12	18:58:25	0.000	0.30
2003/03/12	18:58:30	0.000	0.34
2003/03/12	18:58:35	0.000	0.25
2003/03/12	18:58:40	0.000	0.21
2003/03/12	18:58:45	0.000	0.15
2003/03/12	18:58:50	0.000	0.10
2003/03/12	18:58:55	0.000	0.07
2003/03/12	18:59:00	0.000	0.03
2003/03/12	18:59:05	0.000	0.06
2003/03/12	18:59:10	0.000	0.02
2003/03/12	18:59:15	0.000	0.01
2003/03/12	18:59:20	0.000	0.01
2003/03/12	18:59:25	0.000	0.03
2003/03/12	18:59:30	0.000	0.02
2003/03/12	18:59:35	0.000	0.04
2003/03/12	18:59:40	0.000	0.15
2003/03/12	18:59:45	0.000	0.17
2003/03/12	18:59:50	0.000	0.23
2003/03/12	18:59:55	0.000	0.28
2003/03/12	19:00:00	0.000	0.27
2003/03/12	19:00:05	0.000	0.30
2003/03/12	19:00:10	0.000	0.28
2003/03/12	19:00:15	0.000	0.30
2003/03/12	19:00:20	0.000	0.26
2003/03/12	19:00:25	0.000	0.18
2003/03/12	19:00:30	0.000	0.15
2003/03/12	19:00:35	0.000	0.12
2003/03/12	19:00:40	0.000	0.06
2003/03/12	19:00:45	0.000	0.02
2003/03/12	19:00:50	0.000	0.06
2003/03/12	19:00:55	0.000	0.02
2003/03/12	19:01:00	0.000	-0.01
2003/03/12	19:01:05	0.000	0.03
2003/03/12	19:01:10	0.000	-0.01
2003/03/12	19:01:15	0.000	0.01
2003/03/12	19:01:20	0.000	-0.01
2003/03/12	19:01:25	0.000	0.01
2003/03/12	19:01:30	0.000	0.02
2003/03/12	19:01:35	0.000	-0.01
2003/03/12	19:01:40	0.000	0.01
2003/03/12	19:01:45	0.000	0.01
2003/03/12	19:01:50	0.000	0.01
2003/03/12	19:01:55	0.000	-0.01
2003/03/12	19:02:00	0.000	0.03
2003/03/12	19:02:05	0.000	0.01
2003/03/12	19:02:10	0.000	-0.01
2003/03/12	19:02:15	0.000	0.03
2003/03/12	19:02:20	0.000	-0.02
2003/03/12	19:02:25	0.000	0.00
2003/03/12	19:02:30	0.000	0.00
2003/03/12	19:02:35	0.000	0.00
2003/03/12	19:02:40	0.000	0.02
2003/03/12	19:02:45	0.000	-0.02
2003/03/12	19:02:50	0.000	0.01
2003/03/12	19:02:55	0.000	0.00
2003/03/12	19:03:00	0.000	0.01
2003/03/12	19:03:05	0.000	0.01
2003/03/12	19:03:10	0.000	0.04
2003/03/12	19:03:15	0.000	0.04
2003/03/12	19:03:20	0.000	0.00
2003/03/12	19:03:25	0.000	0.06
2003/03/12	19:03:30	0.000	0.03
2003/03/12	19:03:35	0.000	0.04
2003/03/12	19:03:40	0.000	0.06
2003/03/12	19:03:45	0.000	0.05
2003/03/12	19:03:50	0.000	0.06
2003/03/12	19:03:55	0.000	0.04
2003/03/12	19:04:00	0.000	0.08
2003/03/12	19:04:05	0.000	0.08
2003/03/12	19:04:10	0.000	0.07
2003/03/12	19:04:15	0.000	0.08
2003/03/12	19:04:20	0.000	0.10
2003/03/12	19:04:25	0.000	0.09
2003/03/12	19:04:30	0.000	0.07
2003/03/12	19:04:35	0.000	0.12
2003/03/12	19:04:40	0.000	0.10
2003/03/12	19:04:45	0.000	0.08
2003/03/12	19:04:50	0.000	0.11
2003/03/12	19:04:55	0.000	0.08
2003/03/12	19:05:00	0.000	0.09
2003/03/12	19:05:05	0.000	0.08
2003/03/12	19:05:10	0.000	0.10
2003/03/12	19:05:15	0.000	0.11
2003/03/12	19:05:20	0.000	0.08
2003/03/12	19:05:25	0.000	0.12
2003/03/12	19:05:30	0.000	0.12
2003/03/12	19:05:35	0.000	0.11
2003/03/12	19:05:40	0.000	0.09
2003/03/12	19:05:45	0.000	0.13
2003/03/12	19:05:50	0.000	0.12
2003/03/12	19:05:55	0.000	0.08
2003/03/12	19:06:00	0.000	0.13
2003/03/12	19:06:05	0.000	0.09
2003/03/12	19:06:10	0.000	0.11
2003/03/12	19:06:15	0.000	0.11
2003/03/12	19:06:20	0.000	0.10
2003/03/12	19:06:25	0.000	0.11
2003/03/12	19:06:30	0.000	0.09
2003/03/12	19:06:35	0.000	0.13
2003/03/12	19:06:40	0.000	0.12
2003/03/12	19:06:45	0.000	0.12
2003/03/12	19:06:50	0.000	0.13
2003/03/12	19:06:55	0.000	0.14
2003/03/12	19:07:00	0.000	0.13
2003/03/12	19:07:05	0.000	0.10
2003/03/12	19:07:10	0.000	0.15
2003/03/12	19:07:15	0.000	0.12
2003/03/12	19:07:20	0.000	0.12
2003/03/12	19:07:25	0.000	0.14
2003/03/12	19:07:30	0.000	0.12
2003/03/12	19:07:35	0.000	0.14
2003/03/12	19:07:40	0.000	0.12
2003/03/12	19:07:45	0.000	0.14
2003/03/12	19:07:50	0.000	0.14
2003/03/12	19:07:55	0.000	0.13
2003/03/12	19:08:00	0.000	0.16
2003/03/12	19:08:05	0.000	0.16
2003/03/12	19:08:10	0.000	0.15
2003/03/12	19:08:15	0.000	0.13
2003/03/12	19:08:20	0.000	0.17
2003/03/12	19:08:25	0.000	0.14
2003/03/12	19:08:30	0.000	0.13
2003/03/12	19:08:35	0.000	0.17
2003/03/12	19:08:40	0.000	0.13
2003/03/12	19:08:45	0.000	0.15
2003/03/12	19:08:50	0.000	0.14
2003/03/12	19:08:55	0.000	0.15
2003/03/12	19:09:00	0.000	0.17
2003/03/12	19:09:05	0.000	0.14
2003/03/12	19:09:10	0.000	0.17
2003/03/12	19:09:15	0.000	0.17
2003/03/12	19:09:20	0.000	0.17

0.25

18:58:23.101717090343

0.08

18:58:23.101717090343

2003/03/12	18:08:25	0.000	0.15
2003/03/12	18:08:30	0.000	0.19
2003/03/12	18:08:35	0.000	0.17
2003/03/12	18:08:40	0.000	0.15
2003/03/12	18:08:45	0.000	0.19
2003/03/12	18:08:50	0.000	0.15
2003/03/12	18:08:55	0.000	0.17
2003/03/12	18:10:00	0.000	0.15
2003/03/12	18:10:05	0.000	0.17
2003/03/12	18:10:10	0.000	0.20
2003/03/12	18:10:15	0.000	0.17
2003/03/12	18:10:20	0.000	0.19
2003/03/12	18:10:25	0.000	0.19
2003/03/12	18:10:30	0.000	0.19
2003/03/12	18:10:35	0.000	0.20
2003/03/12	18:10:40	0.000	0.22
2003/03/12	18:10:45	0.000	0.21
2003/03/12	18:10:50	0.000	0.18
2003/03/12	18:10:55	0.000	0.23
2003/03/12	18:11:00	0.000	0.19
2003/03/12	18:11:05	0.000	0.20
2003/03/12	18:11:10	0.000	0.21
2003/03/12	18:11:15	0.000	0.19
2003/03/12	18:11:20	0.000	0.21
2003/03/12	18:11:25	0.000	0.20
2003/03/12	18:11:30	0.000	0.23
2003/03/12	18:11:35	0.000	0.23
2003/03/12	18:11:40	0.000	0.22
2003/03/12	18:11:45	0.000	0.23
2003/03/12	18:11:50	0.000	0.25
2003/03/12	18:11:55	0.000	0.24
2003/03/12	18:12:00	0.000	0.21
2003/03/12	18:12:05	0.000	0.27
2003/03/12	18:12:10	0.000	0.24
2003/03/12	18:12:15	0.000	0.23
2003/03/12	18:12:20	0.000	0.28
2003/03/12	18:12:25	0.000	0.23
2003/03/12	18:12:30	0.000	0.25
2003/03/12	18:12:35	0.000	0.24
2003/03/12	18:12:40	0.000	0.28
2003/03/12	18:12:45	0.000	0.28
2003/03/12	18:12:50	0.000	0.24
2003/03/12	18:12:55	0.000	0.27
2003/03/12	18:13:00	0.000	0.27
2003/03/12	18:13:05	0.000	0.28
2003/03/12	18:13:10	0.000	0.25
2003/03/12	18:13:15	0.000	0.29
2003/03/12	18:13:20	0.000	0.28
2003/03/12	18:13:25	0.000	0.24
2003/03/12	18:13:30	0.000	0.29
2003/03/12	18:13:35	0.000	0.24
2003/03/12	18:13:40	0.000	0.27
2003/03/12	18:13:45	0.000	0.28
2003/03/12	18:13:50	0.000	0.28
2003/03/12	18:13:55	0.000	0.27
2003/03/12	18:14:00	0.000	0.25
2003/03/12	18:14:05	0.000	0.28
2003/03/12	18:14:10	0.000	0.27
2003/03/12	18:14:15	0.000	0.27
2003/03/12	18:14:20	0.000	0.28
2003/03/12	18:14:25	0.000	0.29
2003/03/12	18:14:30	0.000	0.29
2003/03/12	18:14:35	0.000	0.25
2003/03/12	18:14:40	0.000	0.30
2003/03/12	18:14:45	0.000	0.29
2003/03/12	18:14:50	0.000	0.27
2003/03/12	18:14:55	0.000	0.28
2003/03/12	18:15:00	0.000	0.28
2003/03/12	18:15:05	0.000	0.28
2003/03/12	18:15:10	0.000	0.25
2003/03/12	18:15:15	0.000	0.28
2003/03/12	18:15:20	0.000	0.28
2003/03/12	18:15:25	0.000	0.27
2003/03/12	18:15:30	0.000	0.30
2003/03/12	18:15:35	0.000	0.30
2003/03/12	18:15:40	0.000	0.29
2003/03/12	18:15:45	0.000	0.28
2003/03/12	18:15:50	0.000	0.31
2003/03/12	18:15:55	0.000	0.28
2003/03/12	18:16:00	0.000	0.27
2003/03/12	18:16:05	0.000	0.31
2003/03/12	18:16:10	0.000	0.28
2003/03/12	18:16:15	0.000	0.30
2003/03/12	18:16:20	0.000	0.29
2003/03/12	18:16:25	0.000	0.32
2003/03/12	18:16:30	0.000	0.32
2003/03/12	18:16:35	0.000	0.29
2003/03/12	18:16:40	0.000	0.32
2003/03/12	18:16:45	0.000	0.34
2003/03/12	18:16:50	0.000	0.33
2003/03/12	18:16:55	0.000	0.32
2003/03/12	18:17:00	0.000	0.33
2003/03/12	18:17:05	0.000	0.34
2003/03/12	18:17:10	0.000	0.32
2003/03/12	18:17:15	0.000	0.37
2003/03/12	18:17:20	0.000	0.32
2003/03/12	18:17:25	0.000	0.35
2003/03/12	18:17:30	0.000	0.34
2003/03/12	18:17:35	0.000	0.32
2003/03/12	18:17:40	0.000	0.28
2003/03/12	18:17:45	0.000	0.19
2003/03/12	18:17:50	0.000	0.18
2003/03/12	18:17:55	0.000	0.11
2003/03/12	18:18:00	0.000	0.07
2003/03/12	18:18:05	0.000	0.05
2003/03/12	18:18:10	0.000	0.08
2003/03/12	18:18:15	0.000	0.04
2003/03/12	18:18:20	0.000	-0.01
2003/03/12	18:18:25	0.000	0.07
2003/03/12	18:18:30	0.000	0.08
2003/03/12	18:18:35	0.000	0.12
2003/03/12	18:18:40	0.000	0.12
2003/03/12	18:18:45	0.000	0.07
2003/03/12	18:18:50	0.000	0.08
2003/03/12	18:18:55	0.000	0.02
2003/03/12	18:19:00	0.000	0.04
2003/03/12	18:19:05	0.000	0.02
2003/03/12	18:19:10	0.000	0.00
2003/03/12	18:19:15	0.000	0.01
2003/03/12	18:19:20	0.000	0.03
2003/03/12	18:19:25	0.000	0.01
2003/03/12	18:19:30	0.000	-0.02
2003/03/12	18:19:35	0.000	0.03
2003/03/12	18:19:40	0.000	0.00
2003/03/12	18:19:45	0.000	-0.01
2003/03/12	18:19:50	0.000	0.02
2003/03/12	18:19:55	0.000	-0.01
2003/03/12	18:20:00	0.000	0.00
2003/03/12	18:20:05	0.000	-0.01
2003/03/12	18:20:10	0.000	0.01
2003/03/12	18:20:15	0.000	0.01
2003/03/12	18:20:20	0.000	-0.01
2003/03/12	18:20:25	0.000	0.02
2003/03/12	18:20:30	0.000	0.02

0.13

18:10:25 18:10:35

0.24

18:14:55 18:15:05

0.19

18:19:35 18:19:45

2003/03/12	19:20:36	0.000	0.01
2003/03/12	19:20:40	0.000	-0.01
2003/03/12	19:20:46	0.000	0.03
2003/03/12	19:20:50	0.000	0.02
2003/03/12	19:20:55	0.000	-0.02
2003/03/12	19:21:00	0.000	0.03
2003/03/12	19:21:06	0.000	-0.02
2003/03/12	19:21:10	0.000	0.01
2003/03/12	19:21:16	0.000	0.00
2003/03/12	19:21:20	0.000	0.01
2003/03/12	19:21:26	0.000	0.02
2003/03/12	19:21:30	0.000	0.01
2003/03/12	19:21:36	0.000	0.05
2003/03/12	19:21:40	0.000	0.04
2003/03/12	19:21:46	0.000	0.04
2003/03/12	19:21:50	0.000	0.05
2003/03/12	19:21:56	0.000	0.07
2003/03/12	19:22:00	0.000	0.06
2003/03/12	19:22:06	0.000	0.03
2003/03/12	19:22:10	0.000	0.08
2003/03/12	19:22:16	0.000	0.04
2003/03/12	19:22:20	0.000	0.06
2003/03/12	19:22:26	0.000	0.07
2003/03/12	19:22:30	0.000	0.06
2003/03/12	19:22:36	0.000	0.08
2003/03/12	19:22:40	0.000	0.06
2003/03/12	19:22:46	0.000	0.08
2003/03/12	19:22:50	0.000	0.08
2003/03/12	19:22:56	0.000	0.07
2003/03/12	19:23:00	0.000	0.09
2003/03/12	19:23:06	0.000	0.10
2003/03/12	19:23:10	0.000	0.08
2003/03/12	19:23:16	0.000	0.06
2003/03/12	19:23:20	0.000	0.11
2003/03/12	19:23:26	0.000	0.08
2003/03/12	19:23:30	0.000	0.07
2003/03/12	19:23:36	0.000	0.10
2003/03/12	19:23:40	0.000	0.07
2003/03/12	19:23:46	0.000	0.09
2003/03/12	19:23:50	0.000	0.07
2003/03/12	19:23:56	0.000	0.09
2003/03/12	19:24:00	0.000	0.10
2003/03/12	19:24:06	0.000	0.08
2003/03/12	19:24:10	0.000	0.10
2003/03/12	19:24:16	0.000	0.12
2003/03/12	19:24:20	0.000	0.10
2003/03/12	19:24:26	0.000	0.08
2003/03/12	19:24:30	0.000	0.13
2003/03/12	19:24:36	0.000	0.10
2003/03/12	19:24:40	0.000	0.08
2003/03/12	19:24:46	0.000	0.13
2003/03/12	19:24:50	0.000	0.08
2003/03/12	19:24:56	0.000	0.10
2003/03/12	19:25:00	0.000	0.10
2003/03/12	19:25:06	0.000	0.10
2003/03/12	19:25:10	0.000	0.12
2003/03/12	19:25:16	0.000	0.09
2003/03/12	19:25:20	0.000	0.12
2003/03/12	19:25:26	0.000	0.13
2003/03/12	19:25:30	0.000	0.12
2003/03/12	19:25:36	0.000	0.12
2003/03/12	19:25:40	0.000	0.15
2003/03/12	19:25:46	0.000	0.14
2003/03/12	19:25:50	0.000	0.11
2003/03/12	19:25:56	0.000	0.16
2003/03/12	19:26:00	0.000	0.12
2003/03/12	19:26:06	0.000	0.13
2003/03/12	19:26:10	0.000	0.14
2003/03/12	19:26:16	0.000	0.12
2003/03/12	19:26:20	0.000	0.14
2003/03/12	19:26:26	0.000	0.12
2003/03/12	19:26:30	0.000	0.15
2003/03/12	19:26:36	0.000	0.15
2003/03/12	19:26:40	0.000	0.14
2003/03/12	19:26:46	0.000	0.15
2003/03/12	19:26:50	0.000	0.17
2003/03/12	19:26:56	0.000	0.16
2003/03/12	19:27:00	0.000	0.13
2003/03/12	19:27:06	0.000	0.19
2003/03/12	19:27:10	0.000	0.16
2003/03/12	19:27:16	0.000	0.15
2003/03/12	19:27:20	0.000	0.18
2003/03/12	19:27:26	0.000	0.16
2003/03/12	19:27:30	0.000	0.17
2003/03/12	19:27:36	0.000	0.16
2003/03/12	19:27:40	0.000	0.19
2003/03/12	19:27:46	0.000	0.19
2003/03/12	19:27:50	0.000	0.17
2003/03/12	19:27:56	0.000	0.20
2003/03/12	19:28:00	0.000	0.21
2003/03/12	19:28:06	0.000	0.19
2003/03/12	19:28:10	0.000	0.18
2003/03/12	19:28:16	0.000	0.22
2003/03/12	19:28:20	0.000	0.21
2003/03/12	19:28:26	0.000	0.18
2003/03/12	19:28:30	0.000	0.22
2003/03/12	19:28:36	0.000	0.18
2003/03/12	19:28:40	0.000	0.21
2003/03/12	19:28:46	0.000	0.20
2003/03/12	19:28:50	0.000	0.20
2003/03/12	19:28:56	0.000	0.21
2003/03/12	19:29:00	0.000	0.20
2003/03/12	19:29:06	0.000	0.23
2003/03/12	19:29:10	0.000	0.23
2003/03/12	19:29:16	0.000	0.23
2003/03/12	19:29:20	0.000	0.23
2003/03/12	19:29:26	0.000	0.28
2003/03/12	19:29:30	0.000	0.24
2003/03/12	19:29:36	0.000	0.21
2003/03/12	19:29:40	0.000	0.26
2003/03/12	19:29:46	0.000	0.22
2003/03/12	19:29:50	0.000	0.23
2003/03/12	19:29:56	0.000	0.24
2003/03/12	19:30:00	0.000	0.23
2003/03/12	19:30:06	0.000	0.26
2003/03/12	19:30:10	0.000	0.22
2003/03/12	19:30:16	0.000	0.24
2003/03/12	19:30:20	0.000	0.24
2003/03/12	19:30:26	0.000	0.24
2003/03/12	19:30:30	0.000	0.28
2003/03/12	19:30:36	0.000	0.29
2003/03/12	19:30:40	0.000	0.25
2003/03/12	19:30:46	0.000	0.22
2003/03/12	19:30:50	0.000	0.26
2003/03/12	19:30:56	0.000	0.26
2003/03/12	19:31:00	0.000	0.24
2003/03/12	19:31:06	0.000	0.27
2003/03/12	19:31:10	0.000	0.24
2003/03/12	19:31:16	0.000	0.27
2003/03/12	19:31:20	0.000	0.26
2003/03/12	19:31:26	0.000	0.28
2003/03/12	19:31:30	0.000	0.26
2003/03/12	19:31:36	0.000	0.28
2003/03/12	19:31:40	0.000	0.29

0.06

2003/03/12 19:29:00

0.17

2003/03/12 19:30:00

2003/03/12	18:31:45	0.000	0.30
2003/03/12	18:31:50	0.000	0.29
2003/03/12	18:31:55	0.000	0.27
2003/03/12	18:32:00	0.000	0.32
2003/03/12	18:32:05	0.000	0.30
2003/03/12	18:32:10	0.000	0.28
2003/03/12	18:32:15	0.000	0.32
2003/03/12	18:32:20	0.000	0.28
2003/03/12	18:32:25	0.000	0.31
2003/03/12	18:32:30	0.000	0.32
2003/03/12	18:32:35	0.000	0.32
2003/03/12	18:32:40	0.000	0.34
2003/03/12	18:32:45	0.000	0.31
2003/03/12	18:32:50	0.000	0.33
2003/03/12	18:32:55	0.000	0.34
2003/03/12	18:33:00	0.000	0.34
2003/03/12	18:33:05	0.000	0.34
2003/03/12	18:33:10	0.000	0.38
2003/03/12	18:33:15	0.000	0.38
2003/03/12	18:33:20	0.000	0.33
2003/03/12	18:33:25	0.000	0.38
2003/03/12	18:33:30	0.000	0.34
2003/03/12	18:33:35	0.000	0.35
2003/03/12	18:33:40	0.000	0.37
2003/03/12	18:33:45	0.000	0.35
2003/03/12	18:33:50	0.000	0.37
2003/03/12	18:33:55	0.000	0.35
2003/03/12	18:34:00	0.000	0.38
2003/03/12	18:34:05	0.000	0.38
2003/03/12	18:34:10	0.000	0.37
2003/03/12	18:34:15	0.000	0.38
2003/03/12	18:34:20	0.000	0.40
2003/03/12	18:34:25	0.000	0.40
2003/03/12	18:34:30	0.000	0.38
2003/03/12	18:34:35	0.000	0.41
2003/03/12	18:34:40	0.000	0.37
2003/03/12	18:34:45	0.000	0.38
2003/03/12	18:34:50	0.000	0.40
2003/03/12	18:34:55	0.000	0.37
2003/03/12	18:35:00	0.000	0.35
2003/03/12	18:35:05	0.000	0.27
2003/03/12	18:35:10	0.000	0.22
2003/03/12	18:35:15	0.000	0.18
2003/03/12	18:35:20	0.000	0.10
2003/03/12	18:35:25	0.000	0.09
2003/03/12	18:35:30	0.000	0.07
2003/03/12	18:35:35	0.000	0.04
2003/03/12	18:35:40	0.000	0.01
2003/03/12	18:35:45	0.000	0.06
2003/03/12	18:35:50	0.000	0.01
2003/03/12	18:35:55	0.000	-0.01
2003/03/12	18:36:00	0.000	0.08
2003/03/12	18:36:05	0.000	0.09
2003/03/12	18:36:10	0.000	0.19
2003/03/12	18:36:15	0.000	0.24
2003/03/12	18:36:20	0.000	0.28
2003/03/12	18:36:25	0.000	0.31
2003/03/12	18:36:30	0.000	0.31
2003/03/12	18:36:35	0.000	0.35
2003/03/12	18:36:40	0.000	0.35
2003/03/12	18:36:45	0.000	0.32
2003/03/12	18:36:50	0.000	0.28
2003/03/12	18:36:55	0.000	0.22
2003/03/12	18:37:00	0.000	0.15
2003/03/12	18:37:05	0.000	0.07
2003/03/12	18:37:10	0.000	0.09
2003/03/12	18:37:15	0.000	0.02
2003/03/12	18:37:20	0.000	0.03
2003/03/12	18:37:25	0.000	0.03
2003/03/12	18:37:30	0.000	0.00
2003/03/12	18:37:35	0.000	0.02
2003/03/12	18:37:40	0.000	-0.02
2003/03/12	18:37:45	0.000	0.01
2003/03/12	18:37:50	0.000	0.00
2003/03/12	18:37:55	0.000	0.00
2003/03/12	18:38:00	0.000	0.02
2003/03/12	18:38:05	0.000	0.03
2003/03/12	18:38:10	0.000	0.01
2003/03/12	18:38:15	0.000	-0.02
2003/03/12	18:38:20	0.000	0.03
2003/03/12	18:38:25	0.000	0.00
2003/03/12	18:38:30	0.000	-0.01
2003/03/12	18:38:35	0.000	0.02
2003/03/12	18:38:40	0.000	-0.01
2003/03/12	18:38:45	0.000	0.01
2003/03/12	18:38:50	0.000	-0.01
2003/03/12	18:38:55	0.000	0.01
2003/03/12	18:39:00	0.000	0.01
2003/03/12	18:39:05	0.000	-0.01
2003/03/12	18:39:10	0.000	0.01
2003/03/12	18:39:15	0.000	0.02
2003/03/12	18:39:20	0.000	0.01
2003/03/12	18:39:25	0.000	-0.01
2003/03/12	18:39:30	0.000	0.04
2003/03/12	18:39:35	0.000	0.03
2003/03/12	18:39:40	0.000	0.01
2003/03/12	18:39:45	0.000	0.06
2003/03/12	18:39:50	0.000	0.02
2003/03/12	18:39:55	0.000	0.05
2003/03/12	18:40:00	0.000	0.04
2003/03/12	18:40:05	0.000	0.06
2003/03/12	18:40:10	0.000	0.09
2003/03/12	18:40:15	0.000	0.05
2003/03/12	18:40:20	0.000	0.08
2003/03/12	18:40:25	0.000	0.09
2003/03/12	18:40:30	0.000	0.08
2003/03/12	18:40:35	0.000	0.08
2003/03/12	18:40:40	0.000	0.11
2003/03/12	18:40:45	0.000	0.10
2003/03/12	18:40:50	0.000	0.06
2003/03/12	18:40:55	0.000	0.11
2003/03/12	18:41:00	0.000	0.07
2003/03/12	18:41:05	0.000	0.09
2003/03/12	18:41:10	0.000	0.10
2003/03/12	18:41:15	0.000	0.08
2003/03/12	18:41:20	0.000	0.10
2003/03/12	18:41:25	0.000	0.08
2003/03/12	18:41:30	0.000	0.11
2003/03/12	18:41:35	0.000	0.10
2003/03/12	18:41:40	0.000	0.10
2003/03/12	18:41:45	0.000	0.10
2003/03/12	18:41:50	0.000	0.13
2003/03/12	18:41:55	0.000	0.11
2003/03/12	18:42:00	0.000	0.08
2003/03/12	18:42:05	0.000	0.13
2003/03/12	18:42:10	0.000	0.10
2003/03/12	18:42:15	0.000	0.09
2003/03/12	18:42:20	0.000	0.12
2003/03/12	18:42:25	0.000	0.09
2003/03/12	18:42:30	0.000	0.10
2003/03/12	18:42:35	0.000	0.09
2003/03/12	18:42:40	0.000	0.12
2003/03/12	18:42:45	0.000	0.12
2003/03/12	18:42:50	0.000	0.10

0.31

18:35:07:18:40:00:00:00

0.08

18:39:07:18:40:00:00:00

2003/03/12	18:42:58	0.000	0.13
2003/03/12	18:43:00	0.000	0.14
2003/03/12	18:43:05	0.000	0.13
2003/03/12	18:43:10	0.000	0.10
2003/03/12	18:43:15	0.000	0.16
2003/03/12	18:43:20	0.000	0.12
2003/03/12	18:43:25	0.000	0.10
2003/03/12	18:43:30	0.000	0.14
2003/03/12	18:43:35	0.000	0.10
2003/03/12	18:43:40	0.000	0.13
2003/03/12	18:43:45	0.000	0.11
2003/03/12	18:43:50	0.000	0.12
2003/03/12	18:43:55	0.000	0.13
2003/03/12	18:44:00	0.000	0.11
2003/03/12	18:44:05	0.000	0.14
2003/03/12	18:44:10	0.000	0.14
2003/03/12	18:44:15	0.000	0.13
2003/03/12	18:44:20	0.000	0.12
2003/03/12	18:44:25	0.000	0.15
2003/03/12	18:44:30	0.000	0.14
2003/03/12	18:44:35	0.000	0.11
2003/03/12	18:44:40	0.000	0.16
2003/03/12	18:44:45	0.000	0.11
2003/03/12	18:44:50	0.000	0.13
2003/03/12	18:44:55	0.000	0.13
2003/03/12	18:45:00	0.000	0.12
2003/03/12	18:45:05	0.000	0.15
2003/03/12	18:45:10	0.000	0.12
2003/03/12	18:45:15	0.000	0.16
2003/03/12	18:45:20	0.000	0.15
2003/03/12	18:45:25	0.000	0.14
2003/03/12	18:45:30	0.000	0.16
2003/03/12	18:45:35	0.000	0.17
2003/03/12	18:45:40	0.000	0.16
2003/03/12	18:45:45	0.000	0.13
2003/03/12	18:45:50	0.000	0.19
2003/03/12	18:45:55	0.000	0.15
2003/03/12	18:46:00	0.000	0.15
2003/03/12	18:46:05	0.000	0.18
2003/03/12	18:46:10	0.000	0.15
2003/03/12	18:46:15	0.000	0.18
2003/03/12	18:46:20	0.000	0.16
2003/03/12	18:46:25	0.000	0.19
2003/03/12	18:46:30	0.000	0.19
2003/03/12	18:46:35	0.000	0.17
2003/03/12	18:46:40	0.000	0.20
2003/03/12	18:46:45	0.000	0.22
2003/03/12	18:46:50	0.000	0.20
2003/03/12	18:46:55	0.000	0.18
2003/03/12	18:47:00	0.000	0.23
2003/03/12	18:47:05	0.000	0.21
2003/03/12	18:47:10	0.000	0.19
2003/03/12	18:47:15	0.000	0.24
2003/03/12	18:47:20	0.000	0.20
2003/03/12	18:47:25	0.000	0.22
2003/03/12	18:47:30	0.000	0.22
2003/03/12	18:47:35	0.000	0.23
2003/03/12	18:47:40	0.000	0.25
2003/03/12	18:47:45	0.000	0.22
2003/03/12	18:47:50	0.000	0.24
2003/03/12	18:47:55	0.000	0.25
2003/03/12	18:48:00	0.000	0.24
2003/03/12	18:48:05	0.000	0.23
2003/03/12	18:48:10	0.000	0.27
2003/03/12	18:48:15	0.000	0.25
2003/03/12	18:48:20	0.000	0.22
2003/03/12	18:48:25	0.000	0.27
2003/03/12	18:48:30	0.000	0.23
2003/03/12	18:48:35	0.000	0.25
2003/03/12	18:48:40	0.000	0.25
2003/03/12	18:48:45	0.000	0.25
2003/03/12	18:48:50	0.000	0.27
2003/03/12	18:48:55	0.000	0.25
2003/03/12	18:49:00	0.000	0.28
2003/03/12	18:49:05	0.000	0.27
2003/03/12	18:49:10	0.000	0.27
2003/03/12	18:49:15	0.000	0.28
2003/03/12	18:49:20	0.000	0.30
2003/03/12	18:49:25	0.000	0.29
2003/03/12	18:49:30	0.000	0.28
2003/03/12	18:49:35	0.000	0.31
2003/03/12	18:49:40	0.000	0.27
2003/03/12	18:49:45	0.000	0.27
2003/03/12	18:49:50	0.000	0.30
2003/03/12	18:49:55	0.000	0.28
2003/03/12	18:50:00	0.000	0.29
2003/03/12	18:50:05	0.000	0.27
2003/03/12	18:50:10	0.000	0.30
2003/03/12	18:50:15	0.000	0.30
2003/03/12	18:50:20	0.000	0.29
2003/03/12	18:50:25	0.000	0.32
2003/03/12	18:50:30	0.000	0.33
2003/03/12	18:50:35	0.000	0.31
2003/03/12	18:50:40	0.000	0.29
2003/03/12	18:50:45	0.000	0.34
2003/03/12	18:50:50	0.000	0.32
2003/03/12	18:50:55	0.000	0.30
2003/03/12	18:51:00	0.000	0.34
2003/03/12	18:51:05	0.000	0.31
2003/03/12	18:51:10	0.000	0.33
2003/03/12	18:51:15	0.000	0.32
2003/03/12	18:51:20	0.000	0.33
2003/03/12	18:51:25	0.000	0.34
2003/03/12	18:51:30	0.000	0.32
2003/03/12	18:51:35	0.000	0.35
2003/03/12	18:51:40	0.000	0.35
2003/03/12	18:51:45	0.000	0.34
2003/03/12	18:51:50	0.000	0.33
2003/03/12	18:51:55	0.000	0.35
2003/03/12	18:52:00	0.000	0.35
2003/03/12	18:52:05	0.000	0.32
2003/03/12	18:52:10	0.000	0.37
2003/03/12	18:52:15	0.000	0.32
2003/03/12	18:52:20	0.000	0.35
2003/03/12	18:52:25	0.000	0.35
2003/03/12	18:52:30	0.000	0.34
2003/03/12	18:52:35	0.000	0.37
2003/03/12	18:52:40	0.000	0.33
2003/03/12	18:52:45	0.000	0.37
2003/03/12	18:52:50	0.000	0.38
2003/03/12	18:52:55	0.000	0.38
2003/03/12	18:53:00	0.000	0.37
2003/03/12	18:53:05	0.000	0.38
2003/03/12	18:53:10	0.000	0.37
2003/03/12	18:53:15	0.000	0.35
2003/03/12	18:53:20	0.000	0.40
2003/03/12	18:53:25	0.000	0.38
2003/03/12	18:53:30	0.000	0.38
2003/03/12	18:53:35	0.000	0.38
2003/03/12	18:53:40	0.000	0.38
2003/03/12	18:53:45	0.000	0.38
2003/03/12	18:53:50	0.000	0.35
2003/03/12	18:53:55	0.000	0.38
2003/03/12	18:54:00	0.000	0.37

0.11

2003/03/12 18:54:00

0.22

2003/03/12 18:54:00

2003/03/12	19:54:05	0.000	0.31
2003/03/12	19:54:10	0.000	0.27
2003/03/12	19:54:15	0.000	0.21
2003/03/12	19:54:20	0.000	0.16
2003/03/12	19:54:25	0.000	0.07
2003/03/12	19:54:30	0.000	0.09
2003/03/12	19:54:35	0.000	0.04
2003/03/12	19:54:40	0.000	0.02
2003/03/12	19:54:45	0.000	0.04
2003/03/12	19:54:50	0.000	0.01
2003/03/12	19:54:55	0.000	0.09
2003/03/12	19:55:00	0.000	0.13
2003/03/12	19:55:05	0.000	0.20
2003/03/12	19:55:10	0.000	0.24
2003/03/12	19:55:15	0.000	0.24
2003/03/12	19:55:20	0.000	0.27
2003/03/12	19:55:25	0.000	0.28
2003/03/12	19:55:30	0.000	0.26
2003/03/12	19:55:35	0.000	0.20
2003/03/12	19:55:40	0.000	0.20
2003/03/12	19:55:45	0.000	0.18
2003/03/12	19:55:50	0.000	0.09
2003/03/12	19:55:55	0.000	0.11
2003/03/12	19:56:00	0.000	0.04
2003/03/12	19:56:05	0.000	0.04
2003/03/12	19:56:10	0.000	0.03
2003/03/12	19:56:15	0.000	0.01
2003/03/12	19:56:20	0.000	0.02
2003/03/12	19:56:25	0.000	-0.01
2003/03/12	19:56:30	0.000	0.02
2003/03/12	19:56:35	0.000	0.00
2003/03/12	19:56:40	0.000	0.00
2003/03/12	19:56:45	0.000	0.01
2003/03/12	19:56:50	0.000	0.03
2003/03/12	19:56:55	0.000	0.02
2003/03/12	19:57:00	0.000	-0.02
2003/03/12	19:57:05	0.000	0.03
2003/03/12	19:57:10	0.000	0.00
2003/03/12	19:57:15	0.000	0.01
2003/03/12	19:57:20	0.000	0.03
2003/03/12	19:57:25	0.000	0.02
2003/03/12	19:57:30	0.000	0.04
2003/03/12	19:57:35	0.000	0.02
2003/03/12	19:57:40	0.000	0.05
2003/03/12	19:57:45	0.000	0.05
2003/03/12	19:57:50	0.000	0.05
2003/03/12	19:57:55	0.000	0.08
2003/03/12	19:58:00	0.000	0.09
2003/03/12	19:58:05	0.000	0.08
2003/03/12	19:58:10	0.000	0.06
2003/03/12	19:58:15	0.000	0.11
2003/03/12	19:58:20	0.000	0.09
2003/03/12	19:58:25	0.000	0.05
2003/03/12	19:58:30	0.000	0.12
2003/03/12	19:58:35	0.000	0.08
2003/03/12	19:58:40	0.000	0.11
2003/03/12	19:58:45	0.000	0.09
2003/03/12	19:58:50	0.000	0.11
2003/03/12	19:58:55	0.000	0.12
2003/03/12	19:59:00	0.000	0.10
2003/03/12	19:59:05	0.000	0.13
2003/03/12	19:59:10	0.000	0.13
2003/03/12	19:59:15	0.000	0.13
2003/03/12	19:59:20	0.000	0.11
2003/03/12	19:59:25	0.000	0.15
2003/03/12	19:59:30	0.000	0.13
2003/03/12	19:59:35	0.000	0.11
2003/03/12	19:59:40	0.000	0.15
2003/03/12	19:59:45	0.000	0.11
2003/03/12	19:59:50	0.000	0.13
2003/03/12	19:59:55	0.000	0.13
2003/03/12	20:00:00	0.000	0.13
2003/03/12	20:00:05	0.000	0.15
2003/03/12	20:00:10	0.000	0.12
2003/03/12	20:00:15	0.000	0.15
2003/03/12	20:00:20	0.000	0.16
2003/03/12	20:00:25	0.000	0.14
2003/03/12	20:00:30	0.000	0.16
2003/03/12	20:00:35	0.000	0.17
2003/03/12	20:00:40	0.000	0.16
2003/03/12	20:00:45	0.000	0.13
2003/03/12	20:00:50	0.000	0.16
2003/03/12	20:00:55	0.000	0.14
2003/03/12	20:01:00	0.000	0.15
2003/03/12	20:01:05	0.000	0.17
2003/03/12	20:01:10	0.000	0.15
2003/03/12	20:01:15	0.000	0.18
2003/03/12	20:01:20	0.000	0.15
2003/03/12	20:01:25	0.000	0.18
2003/03/12	20:01:30	0.000	0.18
2003/03/12	20:01:35	0.000	0.18
2003/03/12	20:01:40	0.000	0.20
2003/03/12	20:01:45	0.000	0.21
2003/03/12	20:01:50	0.000	0.20
2003/03/12	20:01:55	0.000	0.17
2003/03/12	20:02:00	0.000	0.23
2003/03/12	20:02:05	0.000	0.20
2003/03/12	20:02:10	0.000	0.19
2003/03/12	20:02:15	0.000	0.22
2003/03/12	20:02:20	0.000	0.19
2003/03/12	20:02:25	0.000	0.22
2003/03/12	20:02:30	0.000	0.21
2003/03/12	20:02:35	0.000	0.24
2003/03/12	20:02:40	0.000	0.24
2003/03/12	20:02:45	0.000	0.22
2003/03/12	20:02:50	0.000	0.24
2003/03/12	20:02:55	0.000	0.26
2003/03/12	20:03:00	0.000	0.26
2003/03/12	20:03:05	0.000	0.23
2003/03/12	20:03:10	0.000	0.26
2003/03/12	20:03:15	0.000	0.27
2003/03/12	20:03:20	0.000	0.24
2003/03/12	20:03:25	0.000	0.28
2003/03/12	20:03:30	0.000	0.24
2003/03/12	20:03:35	0.000	0.27
2003/03/12	20:03:40	0.000	0.26
2003/03/12	20:03:45	0.000	0.27
2003/03/12	20:03:50	0.000	0.29
2003/03/12	20:03:55	0.000	0.28
2003/03/12	20:04:00	0.000	0.30
2003/03/12	20:04:05	0.000	0.29
2003/03/12	20:04:10	0.000	0.29
2003/03/12	20:04:15	0.000	0.29
2003/03/12	20:04:20	0.000	0.32
2003/03/12	20:04:25	0.000	0.31
2003/03/12	20:04:30	0.000	0.28
2003/03/12	20:04:35	0.000	0.33
2003/03/12	20:04:40	0.000	0.29
2003/03/12	20:04:45	0.000	0.31
2003/03/12	20:04:50	0.000	0.32
2003/03/12	20:04:55	0.000	0.31
2003/03/12	20:05:00	0.000	0.32
2003/03/12	20:05:05	0.000	0.30
2003/03/12	20:05:10	0.000	0.34

0.30

19:54:55 19:55:05

0.09

19:59:55 20:00:05

0.22

20:04:55 20:05:05

2003/03/12	20:06:15	0.000	0.34
2003/03/12	20:06:20	0.000	0.33
2003/03/12	20:06:26	0.000	0.38
2003/03/12	20:06:30	0.000	0.37
2003/03/12	20:06:36	0.000	0.38
2003/03/12	20:06:40	0.000	0.33
2003/03/12	20:06:46	0.000	0.38
2003/03/12	20:06:50	0.000	0.36
2003/03/12	20:06:55	0.000	0.36
2003/03/12	20:06:00	0.000	0.38
2003/03/12	20:06:05	0.000	0.35
2003/03/12	20:06:10	0.000	0.37
2003/03/12	20:06:15	0.000	0.36
2003/03/12	20:06:20	0.000	0.38
2003/03/12	20:06:25	0.000	0.38
2003/03/12	20:06:30	0.000	0.38
2003/03/12	20:06:35	0.000	0.40
2003/03/12	20:06:40	0.000	0.40
2003/03/12	20:06:45	0.000	0.39
2003/03/12	20:06:50	0.000	0.37
2003/03/12	20:06:55	0.000	0.42
2003/03/12	20:07:00	0.000	0.39
2003/03/12	20:07:05	0.000	0.37
2003/03/12	20:07:10	0.000	0.42
2003/03/12	20:07:15	0.000	0.39
2003/03/12	20:07:20	0.000	0.41
2003/03/12	20:07:25	0.000	0.40
2003/03/12	20:07:30	0.000	0.41
2003/03/12	20:07:35	0.000	0.42
2003/03/12	20:07:40	0.000	0.40
2003/03/12	20:07:45	0.000	0.43
2003/03/12	20:07:50	0.000	0.44
2003/03/12	20:07:55	0.000	0.43
2003/03/12	20:08:00	0.000	0.42
2003/03/12	20:08:05	0.000	0.46
2003/03/12	20:08:10	0.000	0.44
2003/03/12	20:08:15	0.000	0.42
2003/03/12	20:08:20	0.000	0.47
2003/03/12	20:08:25	0.000	0.43
2003/03/12	20:08:30	0.000	0.46
2003/03/12	20:08:35	0.000	0.46
2003/03/12	20:08:40	0.000	0.45
2003/03/12	20:08:45	0.000	0.47
2003/03/12	20:08:50	0.000	0.44
2003/03/12	20:08:55	0.000	0.47
2003/03/12	20:09:00	0.000	0.47
2003/03/12	20:09:05	0.000	0.47
2003/03/12	20:09:10	0.000	0.47
2003/03/12	20:09:15	0.000	0.60
2003/03/12	20:09:20	0.000	0.60
2003/03/12	20:09:25	0.000	0.48
2003/03/12	20:09:30	0.000	0.61
2003/03/12	20:09:35	0.000	0.47
2003/03/12	20:09:40	0.000	0.48
2003/03/12	20:09:45	0.000	0.60
2003/03/12	20:09:50	0.000	0.48
2003/03/12	20:09:55	0.000	0.61
2003/03/12	20:10:00	0.000	0.49
2003/03/12	20:10:05	0.000	0.62
2003/03/12	20:10:10	0.000	0.63
2003/03/12	20:10:15	0.000	0.61
2003/03/12	20:10:20	0.000	0.63
2003/03/12	20:10:25	0.000	0.68
2003/03/12	20:10:30	0.000	0.66
2003/03/12	20:10:35	0.000	0.62
2003/03/12	20:10:40	0.000	0.67
2003/03/12	20:10:45	0.000	0.64
2003/03/12	20:10:50	0.000	0.64
2003/03/12	20:10:55	0.000	0.67
2003/03/12	20:11:00	0.000	0.63
2003/03/12	20:11:05	0.000	0.64
2003/03/12	20:11:10	0.000	0.62
2003/03/12	20:11:15	0.000	0.66
2003/03/12	20:11:20	0.000	0.68
2003/03/12	20:11:25	0.000	0.62
2003/03/12	20:11:30	0.000	0.46
2003/03/12	20:11:35	0.000	0.39
2003/03/12	20:11:40	0.000	0.28
2003/03/12	20:11:45	0.000	0.19
2003/03/12	20:11:50	0.000	0.19
2003/03/12	20:11:55	0.000	0.12
2003/03/12	20:12:00	0.000	0.06
2003/03/12	20:12:05	0.000	0.08
2003/03/12	20:12:10	0.000	0.02
2003/03/12	20:12:15	0.000	0.03
2003/03/12	20:12:20	0.000	0.01
2003/03/12	20:12:25	0.000	0.03
2003/03/12	20:12:30	0.000	0.11
2003/03/12	20:12:35	0.000	0.19
2003/03/12	20:12:40	0.000	0.31
2003/03/12	20:12:45	0.000	0.37
2003/03/12	20:12:50	0.000	0.42
2003/03/12	20:12:55	0.000	0.46
2003/03/12	20:13:00	0.000	0.48
2003/03/12	20:13:05	0.000	0.49
2003/03/12	20:13:10	0.000	0.44
2003/03/12	20:13:15	0.000	0.43
2003/03/12	20:13:20	0.000	0.29
2003/03/12	20:13:25	0.000	0.23
2003/03/12	20:13:30	0.000	0.18
2003/03/12	20:13:35	0.000	0.12
2003/03/12	20:13:40	0.000	0.10
2003/03/12	20:13:45	0.000	0.04
2003/03/12	20:13:50	0.000	0.06
2003/03/12	20:13:55	0.000	0.03
2003/03/12	20:14:00	0.000	0.02
2003/03/12	20:14:05	0.000	0.03
2003/03/12	20:14:10	0.000	0.03
2003/03/12	20:14:15	0.000	0.01
2003/03/12	20:14:20	0.000	-0.02
2003/03/12	20:14:25	0.000	0.03
2003/03/12	20:14:30	0.000	-0.01
2003/03/12	20:14:35	0.000	0.00
2003/03/12	20:14:40	0.000	0.02
2003/03/12	20:14:45	0.000	-0.01
2003/03/12	20:14:50	0.000	0.01
2003/03/12	20:14:55	0.000	-0.02
2003/03/12	20:15:00	0.000	0.01
2003/03/12	20:15:05	0.000	0.01
2003/03/12	20:15:10	0.000	-0.01
2003/03/12	20:15:15	0.000	0.02
2003/03/12	20:15:20	0.000	0.03
2003/03/12	20:15:25	0.000	0.01
2003/03/12	20:15:30	0.000	-0.02
2003/03/12	20:15:35	0.000	0.03
2003/03/12	20:15:40	0.000	0.00
2003/03/12	20:15:45	0.000	-0.01
2003/03/12	20:15:50	0.000	0.03
2003/03/12	20:15:55	0.000	0.01
2003/03/12	20:16:00	0.000	0.03
2003/03/12	20:16:05	0.000	0.02
2003/03/12	20:16:10	0.000	0.06
2003/03/12	20:16:15	0.000	0.08
2003/03/12	20:16:20	0.000	0.04

0.41

2003/03/12 10:00:00

0.27

2003/03/12 10:00:00

2003/03/12	20:16:28	0.000	0.08
2003/03/12	20:16:30	0.000	0.08
2003/03/12	20:16:38	0.000	0.07
2003/03/12	20:16:40	0.000	0.08
2003/03/12	20:16:45	0.000	0.10
2003/03/12	20:16:50	0.000	0.10
2003/03/12	20:16:55	0.000	0.08
2003/03/12	20:17:00	0.000	0.11
2003/03/12	20:17:05	0.000	0.07
2003/03/12	20:17:10	0.000	0.09
2003/03/12	20:17:15	0.000	0.09
2003/03/12	20:17:20	0.000	0.09
2003/03/12	20:17:25	0.000	0.10
2003/03/12	20:17:30	0.000	0.08
2003/03/12	20:17:35	0.000	0.11
2003/03/12	20:17:40	0.000	0.11
2003/03/12	20:17:45	0.000	0.10
2003/03/12	20:17:50	0.000	0.10
2003/03/12	20:17:55	0.000	0.12
2003/03/12	20:18:00	0.000	0.11
2003/03/12	20:18:05	0.000	0.08
2003/03/12	20:18:10	0.000	0.12
2003/03/12	20:18:15	0.000	0.09
2003/03/12	20:18:20	0.000	0.10
2003/03/12	20:18:25	0.000	0.10
2003/03/12	20:18:30	0.000	0.09
2003/03/12	20:18:35	0.000	0.10
2003/03/12	20:18:40	0.000	0.08
2003/03/12	20:18:45	0.000	0.11
2003/03/12	20:18:50	0.000	0.10
2003/03/12	20:18:55	0.000	0.10
2003/03/12	20:19:00	0.000	0.13
2003/03/12	20:19:05	0.000	0.12
2003/03/12	20:19:10	0.000	0.12
2003/03/12	20:19:15	0.000	0.09
2003/03/12	20:19:20	0.000	0.15
2003/03/12	20:19:25	0.000	0.11
2003/03/12	20:19:30	0.000	0.11
2003/03/12	20:19:35	0.000	0.13
2003/03/12	20:19:40	0.000	0.11
2003/03/12	20:19:45	0.000	0.13
2003/03/12	20:19:50	0.000	0.10
2003/03/12	20:19:55	0.000	0.13
2003/03/12	20:20:00	0.000	0.13
2003/03/12	20:20:05	0.000	0.11
2003/03/12	20:20:10	0.000	0.15
2003/03/12	20:20:15	0.000	0.15
2003/03/12	20:20:20	0.000	0.13
2003/03/12	20:20:25	0.000	0.12
2003/03/12	20:20:30	0.000	0.15
2003/03/12	20:20:35	0.000	0.14
2003/03/12	20:20:40	0.000	0.12
2003/03/12	20:20:45	0.000	0.15
2003/03/12	20:20:50	0.000	0.12
2003/03/12	20:20:55	0.000	0.14
2003/03/12	20:21:00	0.000	0.12
2003/03/12	20:21:05	0.000	0.14
2003/03/12	20:21:10	0.000	0.15
2003/03/12	20:21:15	0.000	0.12
2003/03/12	20:21:20	0.000	0.15
2003/03/12	20:21:25	0.000	0.17
2003/03/12	20:21:30	0.000	0.15
2003/03/12	20:21:35	0.000	0.14
2003/03/12	20:21:40	0.000	0.15
2003/03/12	20:21:45	0.000	0.15
2003/03/12	20:21:50	0.000	0.14
2003/03/12	20:21:55	0.000	0.15
2003/03/12	20:22:00	0.000	0.14
2003/03/12	20:22:05	0.000	0.17
2003/03/12	20:22:10	0.000	0.15
2003/03/12	20:22:15	0.000	0.15
2003/03/12	20:22:20	0.000	0.15
2003/03/12	20:22:25	0.000	0.15
2003/03/12	20:22:30	0.000	0.15
2003/03/12	20:22:35	0.000	0.15
2003/03/12	20:22:40	0.000	0.15
2003/03/12	20:22:45	0.000	0.15
2003/03/12	20:22:50	0.000	0.21
2003/03/12	20:22:55	0.000	0.21
2003/03/12	20:23:00	0.000	0.17
2003/03/12	20:23:05	0.000	0.22
2003/03/12	20:23:10	0.000	0.15
2003/03/12	20:23:15	0.000	0.20
2003/03/12	20:23:20	0.000	0.21
2003/03/12	20:23:25	0.000	0.19
2003/03/12	20:23:30	0.000	0.21
2003/03/12	20:23:35	0.000	0.19
2003/03/12	20:23:40	0.000	0.23
2003/03/12	20:23:45	0.000	0.23
2003/03/12	20:23:50	0.000	0.23
2003/03/12	20:23:55	0.000	0.24
2003/03/12	20:24:00	0.000	0.25
2003/03/12	20:24:05	0.000	0.25
2003/03/12	20:24:10	0.000	0.21
2003/03/12	20:24:15	0.000	0.27
2003/03/12	20:24:20	0.000	0.24
2003/03/12	20:24:25	0.000	0.23
2003/03/12	20:24:30	0.000	0.25
2003/03/12	20:24:35	0.000	0.23
2003/03/12	20:24:40	0.000	0.25
2003/03/12	20:24:45	0.000	0.23
2003/03/12	20:24:50	0.000	0.25
2003/03/12	20:24:55	0.000	0.25
2003/03/12	20:25:00	0.000	0.24
2003/03/12	20:25:05	0.000	0.27
2003/03/12	20:25:10	0.000	0.25
2003/03/12	20:25:15	0.000	0.27
2003/03/12	20:25:20	0.000	0.24
2003/03/12	20:25:25	0.000	0.25
2003/03/12	20:25:30	0.000	0.27
2003/03/12	20:25:35	0.000	0.25
2003/03/12	20:25:40	0.000	0.25
2003/03/12	20:25:45	0.000	0.25
2003/03/12	20:25:50	0.000	0.27
2003/03/12	20:25:55	0.000	0.25
2003/03/12	20:26:00	0.000	0.27
2003/03/12	20:26:05	0.000	0.27
2003/03/12	20:26:10	0.000	0.25
2003/03/12	20:26:15	0.000	0.25
2003/03/12	20:26:20	0.000	0.25
2003/03/12	20:26:25	0.000	0.25
2003/03/12	20:26:30	0.000	0.27
2003/03/12	20:26:35	0.000	0.30
2003/03/12	20:26:40	0.000	0.25
2003/03/12	20:26:45	0.000	0.25
2003/03/12	20:26:50	0.000	0.30
2003/03/12	20:26:55	0.000	0.25
2003/03/12	20:27:00	0.000	0.25
2003/03/12	20:27:05	0.000	0.25
2003/03/12	20:27:10	0.000	0.25
2003/03/12	20:27:15	0.000	0.30
2003/03/12	20:27:20	0.000	0.27
2003/03/12	20:27:25	0.000	0.25
2003/03/12	20:27:30	0.000	0.25

0.08

XXXXXXXXXXXXXXXXXXXX

0.18

XXXXXXXXXXXXXXXXXXXX

2003/03/12	20:27:30	0.000	0.29
2003/03/12	20:27:40	0.000	0.30
2003/03/12	20:27:45	0.000	0.32
2003/03/12	20:27:50	0.000	0.30
2003/03/12	20:27:55	0.000	0.28
2003/03/12	20:28:00	0.000	0.33
2003/03/12	20:28:05	0.000	0.29
2003/03/12	20:28:10	0.000	0.30
2003/03/12	20:28:15	0.000	0.32
2003/03/12	20:28:20	0.000	0.31
2003/03/12	20:28:25	0.000	0.33
2003/03/12	20:28:30	0.000	0.31
2003/03/12	20:28:35	0.000	0.33
2003/03/12	20:28:40	0.000	0.33
2003/03/12	20:28:45	0.000	0.33
2003/03/12	20:28:50	0.000	0.35
2003/03/12	20:28:55	0.000	0.37
2003/03/12	20:29:00	0.000	0.39
2003/03/12	20:29:05	0.000	0.32
2003/03/12	20:29:10	0.000	0.38
2003/03/12	20:29:15	0.000	0.35
2003/03/12	20:29:20	0.000	0.35
2003/03/12	20:29:25	0.000	0.38
2003/03/12	20:29:30	0.000	0.38
2003/03/12	20:29:35	0.000	0.37
2003/03/12	20:29:40	0.000	0.35
2003/03/12	20:29:45	0.000	0.38
2003/03/12	20:29:50	0.000	0.38
2003/03/12	20:29:55	0.000	0.37
2003/03/12	20:30:00	0.000	0.38
2003/03/12	20:30:05	0.000	0.40
2003/03/12	20:30:10	0.000	0.39
2003/03/12	20:30:15	0.000	0.38
2003/03/12	20:30:20	0.000	0.41
2003/03/12	20:30:25	0.000	0.39
2003/03/12	20:30:30	0.000	0.33
2003/03/12	20:30:35	0.000	0.31
2003/03/12	20:30:40	0.000	0.21
2003/03/12	20:30:45	0.000	0.17
2003/03/12	20:30:50	0.000	0.10
2003/03/12	20:30:55	0.000	0.08
2003/03/12	20:31:00	0.000	0.07
2003/03/12	20:31:05	0.000	0.03
2003/03/12	20:31:10	0.000	0.05
2003/03/12	20:31:15	0.000	0.04
2003/03/12	20:31:20	0.000	0.09
2003/03/12	20:31:25	0.000	0.10
2003/03/12	20:31:30	0.000	0.19
2003/03/12	20:31:35	0.000	0.20
2003/03/12	20:31:40	0.000	0.18
2003/03/12	20:31:45	0.000	0.22
2003/03/12	20:31:50	0.000	0.18
2003/03/12	20:31:55	0.000	0.20
2003/03/12	20:32:00	0.000	0.20
2003/03/12	20:32:05	0.000	0.19
2003/03/12	20:32:10	0.000	0.18
2003/03/12	20:32:15	0.000	0.16
2003/03/12	20:32:20	0.000	0.19
2003/03/12	20:32:25	0.000	0.12
2003/03/12	20:32:30	0.000	0.08
2003/03/12	20:32:35	0.000	0.08
2003/03/12	20:32:40	0.000	0.07
2003/03/12	20:32:45	0.000	0.04
2003/03/12	20:32:50	0.000	0.00
2003/03/12	20:32:55	0.000	0.05
2003/03/12	20:33:00	0.000	0.00
2003/03/12	20:33:05	0.000	0.01
2003/03/12	20:33:10	0.000	0.02
2003/03/12	20:33:15	0.000	0.00
2003/03/12	20:33:20	0.000	0.03
2003/03/12	20:33:25	0.000	0.00
2003/03/12	20:33:30	0.000	0.03
2003/03/12	20:33:35	0.000	0.03
2003/03/12	20:33:40	0.000	0.04
2003/03/12	20:33:45	0.000	0.06
2003/03/12	20:33:50	0.000	0.07
2003/03/12	20:33:55	0.000	0.08
2003/03/12	20:34:00	0.000	0.04
2003/03/12	20:34:05	0.000	0.10
2003/03/12	20:34:10	0.000	0.07
2003/03/12	20:34:15	0.000	0.07
2003/03/12	20:34:20	0.000	0.11
2003/03/12	20:34:25	0.000	0.08
2003/03/12	20:34:30	0.000	0.11
2003/03/12	20:34:35	0.000	0.08
2003/03/12	20:34:40	0.000	0.12
2003/03/12	20:34:45	0.000	0.13
2003/03/12	20:34:50	0.000	0.11
2003/03/12	20:34:55	0.000	0.14
2003/03/12	20:35:00	0.000	0.15
2003/03/12	20:35:05	0.000	0.14
2003/03/12	20:35:10	0.000	0.11
2003/03/12	20:35:15	0.000	0.16
2003/03/12	20:35:20	0.000	0.14
2003/03/12	20:35:25	0.000	0.12
2003/03/12	20:35:30	0.000	0.16
2003/03/12	20:35:35	0.000	0.12
2003/03/12	20:35:40	0.000	0.14
2003/03/12	20:35:45	0.000	0.13
2003/03/12	20:35:50	0.000	0.15
2003/03/12	20:35:55	0.000	0.16
2003/03/12	20:36:00	0.000	0.13
2003/03/12	20:36:05	0.000	0.16
2003/03/12	20:36:10	0.000	0.17
2003/03/12	20:36:15	0.000	0.16
2003/03/12	20:36:20	0.000	0.15
2003/03/12	20:36:25	0.000	0.19
2003/03/12	20:36:30	0.000	0.18
2003/03/12	20:36:35	0.000	0.16
2003/03/12	20:36:40	0.000	0.19
2003/03/12	20:36:45	0.000	0.18
2003/03/12	20:36:50	0.000	0.18
2003/03/12	20:36:55	0.000	0.16
2003/03/12	20:37:00	0.000	0.17
2003/03/12	20:37:05	0.000	0.19
2003/03/12	20:37:10	0.000	0.17
2003/03/12	20:37:15	0.000	0.20
2003/03/12	20:37:20	0.000	0.20
2003/03/12	20:37:25	0.000	0.20
2003/03/12	20:37:30	0.000	0.20
2003/03/12	20:37:35	0.000	0.23
2003/03/12	20:37:40	0.000	0.22
2003/03/12	20:37:45	0.000	0.19
2003/03/12	20:37:50	0.000	0.24
2003/03/12	20:37:55	0.000	0.21
2003/03/12	20:38:00	0.000	0.23
2003/03/12	20:38:05	0.000	0.24
2003/03/12	20:38:10	0.000	0.22
2003/03/12	20:38:15	0.000	0.24
2003/03/12	20:38:20	0.000	0.22
2003/03/12	20:38:25	0.000	0.26
2003/03/12	20:38:30	0.000	0.25
2003/03/12	20:38:35	0.000	0.26
2003/03/12	20:38:40	0.000	0.27

0.30

XXXXXXXXXXXXXXXXXXXX

0.13

XXXXXXXXXXXXXXXXXXXX

2003/03/12	20:38:45	0.000	0.29
2003/03/12	20:38:50	0.000	0.27
2003/03/12	20:38:55	0.000	0.25
2003/03/12	20:39:00	0.000	0.31
2003/03/12	20:39:05	0.000	0.27
2003/03/12	20:39:10	0.000	0.27
2003/03/12	20:39:15	0.000	0.30
2003/03/12	20:39:20	0.000	0.28
2003/03/12	20:39:25	0.000	0.30
2003/03/12	20:39:30	0.000	0.29
2003/03/12	20:39:35	0.000	0.31
2003/03/12	20:39:40	0.000	0.32
2003/03/12	20:39:45	0.000	0.31
2003/03/12	20:39:50	0.000	0.35
2003/03/12	20:39:55	0.000	0.36
2003/03/12	20:40:00	0.000	0.34
2003/03/12	20:40:05	0.000	0.32
2003/03/12	20:40:10	0.000	0.38
2003/03/12	20:40:15	0.000	0.36
2003/03/12	20:40:20	0.000	0.34
2003/03/12	20:40:25	0.000	0.38
2003/03/12	20:40:30	0.000	0.35
2003/03/12	20:40:35	0.000	0.37
2003/03/12	20:40:40	0.000	0.36
2003/03/12	20:40:45	0.000	0.38
2003/03/12	20:40:50	0.000	0.40
2003/03/12	20:40:55	0.000	0.38
2003/03/12	20:41:00	0.000	0.41
2003/03/12	20:41:05	0.000	0.43
2003/03/12	20:41:10	0.000	0.42
2003/03/12	20:41:15	0.000	0.40
2003/03/12	20:41:20	0.000	0.45
2003/03/12	20:41:25	0.000	0.43
2003/03/12	20:41:30	0.000	0.42
2003/03/12	20:41:35	0.000	0.46
2003/03/12	20:41:40	0.000	0.42
2003/03/12	20:41:45	0.000	0.44
2003/03/12	20:41:50	0.000	0.44
2003/03/12	20:41:55	0.000	0.45
2003/03/12	20:42:00	0.000	0.47
2003/03/12	20:42:05	0.000	0.48
2003/03/12	20:42:10	0.000	0.48
2003/03/12	20:42:15	0.000	0.48
2003/03/12	20:42:20	0.000	0.47
2003/03/12	20:42:25	0.000	0.46
2003/03/12	20:42:30	0.000	0.49
2003/03/12	20:42:35	0.000	0.49
2003/03/12	20:42:40	0.000	0.46
2003/03/12	20:42:45	0.000	0.51
2003/03/12	20:42:50	0.000	0.47
2003/03/12	20:42:55	0.000	0.49
2003/03/12	20:43:00	0.000	0.50
2003/03/12	20:43:05	0.000	0.46
2003/03/12	20:43:10	0.000	0.50
2003/03/12	20:43:15	0.000	0.48
2003/03/12	20:43:20	0.000	0.51
2003/03/12	20:43:25	0.000	0.51
2003/03/12	20:43:30	0.000	0.50
2003/03/12	20:43:35	0.000	0.51
2003/03/12	20:43:40	0.000	0.53
2003/03/12	20:43:45	0.000	0.52
2003/03/12	20:43:50	0.000	0.49
2003/03/12	20:43:55	0.000	0.55
2003/03/12	20:44:00	0.000	0.52
2003/03/12	20:44:05	0.000	0.52
2003/03/12	20:44:10	0.000	0.54
2003/03/12	20:44:15	0.000	0.52
2003/03/12	20:44:20	0.000	0.54
2003/03/12	20:44:25	0.000	0.53
2003/03/12	20:44:30	0.000	0.56
2003/03/12	20:44:35	0.000	0.56
2003/03/12	20:44:40	0.000	0.55
2003/03/12	20:44:45	0.000	0.59
2003/03/12	20:44:50	0.000	0.60
2003/03/12	20:44:55	0.000	0.58
2003/03/12	20:45:00	0.000	0.57
2003/03/12	20:45:05	0.000	0.62
2003/03/12	20:45:10	0.000	0.60
2003/03/12	20:45:15	0.000	0.59
2003/03/12	20:45:20	0.000	0.63
2003/03/12	20:45:25	0.000	0.60
2003/03/12	20:45:30	0.000	0.63
2003/03/12	20:45:35	0.000	0.62
2003/03/12	20:45:40	0.000	0.65
2003/03/12	20:45:45	0.000	0.67
2003/03/12	20:45:50	0.000	0.66
2003/03/12	20:45:55	0.000	0.70
2003/03/12	20:46:00	0.000	0.71
2003/03/12	20:46:05	0.000	0.70
2003/03/12	20:46:10	0.000	0.70
2003/03/12	20:46:15	0.000	0.75
2003/03/12	20:46:20	0.000	0.74
2003/03/12	20:46:25	0.000	0.73
2003/03/12	20:46:30	0.000	0.78
2003/03/12	20:46:35	0.000	0.74
2003/03/12	20:46:40	0.000	0.77
2003/03/12	20:46:45	0.000	0.77
2003/03/12	20:46:50	0.000	0.79
2003/03/12	20:46:55	0.000	0.82
2003/03/12	20:47:00	0.000	0.79
2003/03/12	20:47:05	0.000	0.82
2003/03/12	20:47:10	0.000	0.83
2003/03/12	20:47:15	0.000	0.83
2003/03/12	20:47:20	0.000	0.84
2003/03/12	20:47:25	0.000	0.87
2003/03/12	20:47:30	0.000	0.84
2003/03/12	20:47:35	0.000	0.80
2003/03/12	20:47:40	0.000	0.85
2003/03/12	20:47:45	0.000	0.81
2003/03/12	20:47:50	0.000	0.83
2003/03/12	20:47:55	0.000	0.78
2003/03/12	20:48:00	0.000	0.68
2003/03/12	20:48:05	0.000	0.64
2003/03/12	20:48:10	0.000	0.38
2003/03/12	20:48:15	0.000	0.31
2003/03/12	20:48:20	0.000	0.23
2003/03/12	20:48:25	0.000	0.17
2003/03/12	20:48:30	0.000	0.13
2003/03/12	20:48:35	0.000	0.11
2003/03/12	20:48:40	0.000	0.08
2003/03/12	20:48:45	0.000	0.02
2003/03/12	20:48:50	0.000	0.07
2003/03/12	20:48:55	0.000	0.10
2003/03/12	20:49:00	0.000	0.23
2003/03/12	20:49:05	0.000	0.38
2003/03/12	20:49:10	0.000	0.47
2003/03/12	20:49:15	0.000	0.67
2003/03/12	20:49:20	0.000	0.60
2003/03/12	20:49:25	0.000	0.67
2003/03/12	20:49:30	0.000	0.69
2003/03/12	20:49:35	0.000	0.66
2003/03/12	20:49:40	0.000	0.58
2003/03/12	20:49:45	0.000	0.57
2003/03/12	20:49:50	0.000	0.48

0.21

2003/03/12 20:49:50

0.46

2003/03/12 20:49:50

2003/03/12	20:48:58	0.000	0.30
2003/03/12	20:49:00	0.000	0.29
2003/03/12	20:49:05	0.000	0.19
2003/03/12	20:49:10	0.000	0.13
2003/03/12	20:49:15	0.000	0.12
2003/03/12	20:49:20	0.000	0.08
2003/03/12	20:49:25	0.000	0.06
2003/03/12	20:49:30	0.000	0.02
2003/03/12	20:49:35	0.000	0.04
2003/03/12	20:49:40	0.000	0.03
2003/03/12	20:49:45	0.000	0.01
2003/03/12	20:49:50	0.000	0.03
2003/03/12	20:49:55	0.000	0.02
2003/03/12	20:50:00	0.000	0.01
2003/03/12	20:51:05	0.000	-0.01
2003/03/12	20:51:10	0.000	0.03
2003/03/12	20:51:15	0.000	0.01
2003/03/12	20:51:20	0.000	-0.02
2003/03/12	20:51:25	0.000	0.03
2003/03/12	20:51:30	0.000	-0.02
2003/03/12	20:51:35	0.000	0.01
2003/03/12	20:51:40	0.000	-0.01
2003/03/12	20:51:45	0.000	0.00
2003/03/12	20:51:50	0.000	0.02
2003/03/12	20:51:55	0.000	0.00
2003/03/12	20:52:00	0.000	0.04
2003/03/12	20:52:05	0.000	0.04
2003/03/12	20:52:10	0.000	0.05
2003/03/12	20:52:15	0.000	0.04
2003/03/12	20:52:20	0.000	0.08
2003/03/12	20:52:25	0.000	0.07
2003/03/12	20:52:30	0.000	0.04
2003/03/12	20:52:35	0.000	0.09
2003/03/12	20:52:40	0.000	0.05
2003/03/12	20:52:45	0.000	0.07
2003/03/12	20:52:50	0.000	0.07
2003/03/12	20:52:55	0.000	0.07
2003/03/12	20:53:00	0.000	0.10
2003/03/12	20:53:05	0.000	0.09
2003/03/12	20:53:10	0.000	0.09
2003/03/12	20:53:15	0.000	0.09
2003/03/12	20:53:20	0.000	0.09
2003/03/12	20:53:25	0.000	0.10
2003/03/12	20:53:30	0.000	0.11
2003/03/12	20:53:35	0.000	0.09
2003/03/12	20:53:40	0.000	0.07
2003/03/12	20:53:45	0.000	0.12
2003/03/12	20:53:50	0.000	0.08
2003/03/12	20:53:55	0.000	0.08
2003/03/12	20:54:00	0.000	0.10
2003/03/12	20:54:05	0.000	0.08
2003/03/12	20:54:10	0.000	0.10
2003/03/12	20:54:15	0.000	0.07
2003/03/12	20:54:20	0.000	0.10
2003/03/12	20:54:25	0.000	0.10
2003/03/12	20:54:30	0.000	0.09
2003/03/12	20:54:35	0.000	0.11
2003/03/12	20:54:40	0.000	0.12
2003/03/12	20:54:45	0.000	0.11
2003/03/12	20:54:50	0.000	0.08
2003/03/12	20:54:55	0.000	0.13
2003/03/12	20:55:00	0.000	0.10
2003/03/12	20:55:05	0.000	0.09
2003/03/12	20:55:10	0.000	0.11
2003/03/12	20:55:15	0.000	0.08
2003/03/12	20:55:20	0.000	0.10
2003/03/12	20:55:25	0.000	0.08
2003/03/12	20:55:30	0.000	0.11
2003/03/12	20:55:35	0.000	0.11
2003/03/12	20:55:40	0.000	0.09
2003/03/12	20:55:45	0.000	0.12
2003/03/12	20:55:50	0.000	0.14
2003/03/12	20:55:55	0.000	0.12
2003/03/12	20:56:00	0.000	0.10
2003/03/12	20:56:05	0.000	0.15
2003/03/12	20:56:10	0.000	0.14
2003/03/12	20:56:15	0.000	0.11
2003/03/12	20:56:20	0.000	0.15
2003/03/12	20:56:25	0.000	0.11
2003/03/12	20:56:30	0.000	0.13
2003/03/12	20:56:35	0.000	0.12
2003/03/12	20:56:40	0.000	0.13
2003/03/12	20:56:45	0.000	0.15
2003/03/12	20:56:50	0.000	0.13
2003/03/12	20:56:55	0.000	0.17
2003/03/12	20:57:00	0.000	0.18
2003/03/12	20:57:05	0.000	0.18
2003/03/12	20:57:10	0.000	0.16
2003/03/12	20:57:15	0.000	0.18
2003/03/12	20:57:20	0.000	0.18
2003/03/12	20:57:25	0.000	0.18
2003/03/12	20:57:30	0.000	0.21
2003/03/12	20:57:35	0.000	0.18
2003/03/12	20:57:40	0.000	0.19
2003/03/12	20:57:45	0.000	0.19
2003/03/12	20:57:50	0.000	0.18
2003/03/12	20:57:55	0.000	0.20
2003/03/12	20:58:00	0.000	0.18
2003/03/12	20:58:05	0.000	0.21
2003/03/12	20:58:10	0.000	0.21
2003/03/12	20:58:15	0.000	0.21
2003/03/12	20:58:20	0.000	0.23
2003/03/12	20:58:25	0.000	0.25
2003/03/12	20:58:30	0.000	0.24
2003/03/12	20:58:35	0.000	0.21
2003/03/12	20:58:40	0.000	0.26
2003/03/12	20:58:45	0.000	0.22
2003/03/12	20:58:50	0.000	0.23
2003/03/12	20:58:55	0.000	0.25
2003/03/12	20:59:00	0.000	0.23
2003/03/12	20:59:05	0.000	0.23
2003/03/12	20:59:10	0.000	0.22
2003/03/12	20:59:15	0.000	0.23
2003/03/12	20:59:20	0.000	0.26
2003/03/12	20:59:25	0.000	0.25
2003/03/12	20:59:30	0.000	0.27
2003/03/12	20:59:35	0.000	0.28
2003/03/12	20:59:40	0.000	0.27
2003/03/12	20:59:45	0.000	0.25
2003/03/12	20:59:50	0.000	0.30
2003/03/12	20:59:55	0.000	0.29
2003/03/12	21:00:00	0.000	0.29
2003/03/12	21:00:05	0.000	0.29
2003/03/12	21:00:10	0.000	0.26
2003/03/12	21:00:15	0.000	0.28
2003/03/12	21:00:20	0.000	0.28
2003/03/12	21:00:25	0.000	0.29
2003/03/12	21:00:30	0.000	0.29
2003/03/12	21:00:35	0.000	0.27
2003/03/12	21:00:40	0.000	0.29
2003/03/12	21:00:45	0.000	0.31
2003/03/12	21:00:50	0.000	0.30
2003/03/12	21:00:55	0.000	0.27
2003/03/12	21:01:00	0.000	0.32

0.69

XXXXXXXXXXXXXXXXXXXX

0.07

XXXXXXXXXXXXXXXXXXXX

0.18

XXXXXXXXXXXXXXXXXXXX

2003/03/12	21:01:05	0.000	0.30
2003/03/12	21:01:10	0.000	0.28
2003/03/12	21:01:15	0.000	0.32
2003/03/12	21:01:20	0.000	0.28
2003/03/12	21:01:25	0.000	0.31
2003/03/12	21:01:30	0.000	0.29
2003/03/12	21:01:35	0.000	0.31
2003/03/12	21:01:40	0.000	0.33
2003/03/12	21:01:45	0.000	0.30
2003/03/12	21:01:50	0.000	0.32
2003/03/12	21:01:55	0.000	0.34
2003/03/12	21:02:00	0.000	0.33
2003/03/12	21:02:05	0.000	0.31
2003/03/12	21:02:10	0.000	0.35
2003/03/12	21:02:15	0.000	0.34
2003/03/12	21:02:20	0.000	0.31
2003/03/12	21:02:25	0.000	0.36
2003/03/12	21:02:30	0.000	0.31
2003/03/12	21:02:35	0.000	0.33
2003/03/12	21:02:40	0.000	0.32
2003/03/12	21:02:45	0.000	0.32
2003/03/12	21:02:50	0.000	0.34
2003/03/12	21:02:55	0.000	0.32
2003/03/12	21:03:00	0.000	0.35
2003/03/12	21:03:05	0.000	0.35
2003/03/12	21:03:10	0.000	0.34
2003/03/12	21:03:15	0.000	0.34
2003/03/12	21:03:20	0.000	0.37
2003/03/12	21:03:25	0.000	0.36
2003/03/12	21:03:30	0.000	0.32
2003/03/12	21:03:35	0.000	0.37
2003/03/12	21:03:40	0.000	0.33
2003/03/12	21:03:45	0.000	0.35
2003/03/12	21:03:50	0.000	0.36
2003/03/12	21:03:55	0.000	0.35
2003/03/12	21:04:00	0.000	0.36
2003/03/12	21:04:05	0.000	0.34
2003/03/12	21:04:10	0.000	0.37
2003/03/12	21:04:15	0.000	0.37
2003/03/12	21:04:20	0.000	0.38
2003/03/12	21:04:25	0.000	0.38
2003/03/12	21:04:30	0.000	0.39
2003/03/12	21:04:35	0.000	0.38
2003/03/12	21:04:40	0.000	0.35
2003/03/12	21:04:45	0.000	0.40
2003/03/12	21:04:50	0.000	0.36
2003/03/12	21:04:55	0.000	0.37
2003/03/12	21:05:00	0.000	0.39
2003/03/12	21:05:05	0.000	0.37
2003/03/12	21:05:10	0.000	0.40
2003/03/12	21:05:15	0.000	0.37
2003/03/12	21:05:20	0.000	0.39
2003/03/12	21:05:25	0.000	0.40
2003/03/12	21:05:30	0.000	0.39
2003/03/12	21:05:35	0.000	0.42
2003/03/12	21:05:40	0.000	0.43
2003/03/12	21:05:45	0.000	0.41
2003/03/12	21:05:50	0.000	0.39
2003/03/12	21:05:55	0.000	0.47
2003/03/12	21:06:00	0.000	0.45
2003/03/12	21:06:05	0.000	0.44
2003/03/12	21:06:10	0.000	0.47
2003/03/12	21:06:15	0.000	0.43
2003/03/12	21:06:20	0.000	0.45
2003/03/12	21:06:25	0.000	0.43
2003/03/12	21:06:30	0.000	0.45
2003/03/12	21:06:35	0.000	0.46
2003/03/12	21:06:40	0.000	0.43
2003/03/12	21:06:45	0.000	0.45
2003/03/12	21:06:50	0.000	0.46
2003/03/12	21:06:55	0.000	0.47
2003/03/12	21:07:00	0.000	0.44
2003/03/12	21:07:05	0.000	0.43
2003/03/12	21:07:10	0.000	0.32
2003/03/12	21:07:15	0.000	0.23
2003/03/12	21:07:20	0.000	0.21
2003/03/12	21:07:25	0.000	0.11
2003/03/12	21:07:30	0.000	0.10
2003/03/12	21:07:35	0.000	0.07
2003/03/12	21:07:40	0.000	0.05
2003/03/12	21:07:45	0.000	0.07
2003/03/12	21:07:50	0.000	0.09
2003/03/12	21:07:55	0.000	0.17
2003/03/12	21:08:00	0.000	0.18
2003/03/12	21:08:05	0.000	0.15
2003/03/12	21:08:10	0.000	0.12
2003/03/12	21:08:15	0.000	0.12
2003/03/12	21:08:20	0.000	0.09
2003/03/12	21:08:25	0.000	0.03
2003/03/12	21:08:30	0.000	0.07
2003/03/12	21:08:35	0.000	0.01
2003/03/12	21:08:40	0.000	0.02
2003/03/12	21:08:45	0.000	0.02
2003/03/12	21:08:50	0.000	0.00
2003/03/12	21:08:55	0.000	0.01
2003/03/12	21:09:00	0.000	-0.01
2003/03/12	21:09:05	0.000	0.01
2003/03/12	21:09:10	0.000	0.00
2003/03/12	21:09:15	0.000	0.00
2003/03/12	21:09:20	0.000	0.01
2003/03/12	21:09:25	0.000	0.03
2003/03/12	21:09:30	0.000	0.03
2003/03/12	21:09:35	0.000	0.00
2003/03/12	21:09:40	0.000	0.05
2003/03/12	21:09:45	0.000	0.02
2003/03/12	21:09:50	0.000	0.03
2003/03/12	21:09:55	0.000	0.05
2003/03/12	21:10:00	0.000	0.03
2003/03/12	21:10:05	0.000	0.05
2003/03/12	21:10:10	0.000	0.04
2003/03/12	21:10:15	0.000	0.08
2003/03/12	21:10:20	0.000	0.08
2003/03/12	21:10:25	0.000	0.06
2003/03/12	21:10:30	0.000	0.12
2003/03/12	21:10:35	0.000	0.13
2003/03/12	21:10:40	0.000	0.12
2003/03/12	21:10:45	0.000	0.10
2003/03/12	21:10:50	0.000	0.15
2003/03/12	21:10:55	0.000	0.13
2003/03/12	21:11:00	0.000	0.12
2003/03/12	21:11:05	0.000	0.16
2003/03/12	21:11:10	0.000	0.12
2003/03/12	21:11:15	0.000	0.15
2003/03/12	21:11:20	0.000	0.13
2003/03/12	21:11:25	0.000	0.16
2003/03/12	21:11:30	0.000	0.16
2003/03/12	21:11:35	0.000	0.14
2003/03/12	21:11:40	0.000	0.17
2003/03/12	21:11:45	0.000	0.16
2003/03/12	21:11:50	0.000	0.17
2003/03/12	21:11:55	0.000	0.15
2003/03/12	21:12:00	0.000	0.20
2003/03/12	21:12:05	0.000	0.18
2003/03/12	21:12:10	0.000	0.16

0.33

2003/03/12 21:05:00

0.23

2003/03/12 21:09:00

2003/03/12	21:12:15	0.000	0.20
2003/03/12	21:12:20	0.000	0.18
2003/03/12	21:12:25	0.000	0.19
2003/03/12	21:12:30	0.000	0.18
2003/03/12	21:12:35	0.000	0.18
2003/03/12	21:12:40	0.000	0.20
2003/03/12	21:12:45	0.000	0.17
2003/03/12	21:12:50	0.000	0.20
2003/03/12	21:12:55	0.000	0.21
2003/03/12	21:13:00	0.000	0.21
2003/03/12	21:13:05	0.000	0.18
2003/03/12	21:13:10	0.000	0.23
2003/03/12	21:13:15	0.000	0.21
2003/03/12	21:13:20	0.000	0.20
2003/03/12	21:13:25	0.000	0.25
2003/03/12	21:13:30	0.000	0.21
2003/03/12	21:13:35	0.000	0.23
2003/03/12	21:13:40	0.000	0.23
2003/03/12	21:13:45	0.000	0.23
2003/03/12	21:13:50	0.000	0.25
2003/03/12	21:13:55	0.000	0.22
2003/03/12	21:14:00	0.000	0.25
2003/03/12	21:14:05	0.000	0.25
2003/03/12	21:14:10	0.000	0.25
2003/03/12	21:14:15	0.000	0.27
2003/03/12	21:14:20	0.000	0.30
2003/03/12	21:14:25	0.000	0.29
2003/03/12	21:14:30	0.000	0.28
2003/03/12	21:14:35	0.000	0.31
2003/03/12	21:14:40	0.000	0.27
2003/03/12	21:14:45	0.000	0.29
2003/03/12	21:14:50	0.000	0.30
2003/03/12	21:14:55	0.000	0.29
2003/03/12	21:15:00	0.000	0.32
2003/03/12	21:15:05	0.000	0.30
2003/03/12	21:15:10	0.000	0.34
2003/03/12	21:15:15	0.000	0.34
2003/03/12	21:15:20	0.000	0.33
2003/03/12	21:15:25	0.000	0.35
2003/03/12	21:15:30	0.000	0.37
2003/03/12	21:15:35	0.000	0.38
2003/03/12	21:15:40	0.000	0.34
2003/03/12	21:15:45	0.000	0.40
2003/03/12	21:15:50	0.000	0.38
2003/03/12	21:15:55	0.000	0.36
2003/03/12	21:16:00	0.000	0.39
2003/03/12	21:16:05	0.000	0.37
2003/03/12	21:16:10	0.000	0.39
2003/03/12	21:16:15	0.000	0.39
2003/03/12	21:16:20	0.000	0.41
2003/03/12	21:16:25	0.000	0.41
2003/03/12	21:16:30	0.000	0.40
2003/03/12	21:16:35	0.000	0.44
2003/03/12	21:16:40	0.000	0.45
2003/03/12	21:16:45	0.000	0.44
2003/03/12	21:16:50	0.000	0.42
2003/03/12	21:16:55	0.000	0.48
2003/03/12	21:17:00	0.000	0.48
2003/03/12	21:17:05	0.000	0.45
2003/03/12	21:17:10	0.000	0.49
2003/03/12	21:17:15	0.000	0.48
2003/03/12	21:17:20	0.000	0.49
2003/03/12	21:17:25	0.000	0.47
2003/03/12	21:17:30	0.000	0.50
2003/03/12	21:17:35	0.000	0.50
2003/03/12	21:17:40	0.000	0.49
2003/03/12	21:17:45	0.000	0.53
2003/03/12	21:17:50	0.000	0.54
2003/03/12	21:17:55	0.000	0.53
2003/03/12	21:18:00	0.000	0.62
2003/03/12	21:18:05	0.000	0.57
2003/03/12	21:18:10	0.000	0.58
2003/03/12	21:18:15	0.000	0.55
2003/03/12	21:18:20	0.000	0.58
2003/03/12	21:18:25	0.000	0.54
2003/03/12	21:18:30	0.000	0.55
2003/03/12	21:18:35	0.000	0.58
2003/03/12	21:18:40	0.000	0.58
2003/03/12	21:18:45	0.000	0.60
2003/03/12	21:18:50	0.000	0.57
2003/03/12	21:18:55	0.000	0.60
2003/03/12	21:19:00	0.000	0.61
2003/03/12	21:19:05	0.000	0.61
2003/03/12	21:19:10	0.000	0.61
2003/03/12	21:19:15	0.000	0.64
2003/03/12	21:19:20	0.000	0.63
2003/03/12	21:19:25	0.000	0.60
2003/03/12	21:19:30	0.000	0.65
2003/03/12	21:19:35	0.000	0.62
2003/03/12	21:19:40	0.000	0.64
2003/03/12	21:19:45	0.000	0.68
2003/03/12	21:19:50	0.000	0.68
2003/03/12	21:19:55	0.000	0.68
2003/03/12	21:20:00	0.000	0.65
2003/03/12	21:20:05	0.000	0.69
2003/03/12	21:20:10	0.000	0.69
2003/03/12	21:20:15	0.000	0.69
2003/03/12	21:20:20	0.000	0.70
2003/03/12	21:20:25	0.000	0.72
2003/03/12	21:20:30	0.000	0.72
2003/03/12	21:20:35	0.000	0.68
2003/03/12	21:20:40	0.000	0.74
2003/03/12	21:20:45	0.000	0.70
2003/03/12	21:20:50	0.000	0.71
2003/03/12	21:20:55	0.000	0.73
2003/03/12	21:21:00	0.000	0.72
2003/03/12	21:21:05	0.000	0.74
2003/03/12	21:21:10	0.000	0.73
2003/03/12	21:21:15	0.000	0.76
2003/03/12	21:21:20	0.000	0.77
2003/03/12	21:21:25	0.000	0.78
2003/03/12	21:21:30	0.000	0.78
2003/03/12	21:21:35	0.000	0.81
2003/03/12	21:21:40	0.000	0.80
2003/03/12	21:21:45	0.000	0.77
2003/03/12	21:21:50	0.000	0.89
2003/03/12	21:21:55	0.000	0.80
2003/03/12	21:22:00	0.000	0.78
2003/03/12	21:22:05	0.000	0.82
2003/03/12	21:22:10	0.000	0.80
2003/03/12	21:22:15	0.000	0.82
2003/03/12	21:22:20	0.000	0.81
2003/03/12	21:22:25	0.000	0.85
2003/03/12	21:22:30	0.000	0.88
2003/03/12	21:22:35	0.000	0.85
2003/03/12	21:22:40	0.000	0.89
2003/03/12	21:22:45	0.000	0.80
2003/03/12	21:22:50	0.000	0.89
2003/03/12	21:22:55	0.000	0.87
2003/03/12	21:23:00	0.000	0.89
2003/03/12	21:23:05	0.000	0.91
2003/03/12	21:23:10	0.000	0.89
2003/03/12	21:23:15	0.000	0.84
2003/03/12	21:23:20	0.000	0.91

0.19

XXXXXXXXXXXXXXXXXXXX

0.49

XXXXXXXXXXXXXXXXXXXX

2003/03/12	21:23:25	0.000	0.04
2003/03/12	21:23:30	0.000	0.03
2003/03/12	21:23:35	0.000	0.06
2003/03/12	21:23:40	0.000	0.07
2003/03/12	21:23:45	0.000	0.06
2003/03/12	21:23:50	0.000	0.09
2003/03/12	21:23:55	0.000	1.00
2003/03/12	21:24:00	0.000	0.06
2003/03/12	21:24:05	0.000	0.06
2003/03/12	21:24:10	0.000	1.00
2003/03/12	21:24:15	0.000	0.09
2003/03/12	21:24:20	0.000	0.02
2003/03/12	21:24:25	0.000	0.05
2003/03/12	21:24:30	0.000	0.48
2003/03/12	21:24:35	0.000	0.39
2003/03/12	21:24:40	0.000	0.35
2003/03/12	21:24:45	0.000	0.29
2003/03/12	21:24:50	0.000	0.24
2003/03/12	21:24:55	0.000	0.15
2003/03/12	21:25:00	0.000	0.14
2003/03/12	21:25:05	0.000	0.11
2003/03/12	21:25:10	0.000	0.07
2003/03/12	21:25:15	0.000	0.05
2003/03/12	21:25:20	0.000	0.10
2003/03/12	21:25:25	0.000	0.20
2003/03/12	21:25:30	0.000	0.50
2003/03/12	21:25:35	0.000	0.69
2003/03/12	21:25:40	0.000	0.70
2003/03/12	21:25:45	0.000	0.74
2003/03/12	21:25:50	0.000	0.81
2003/03/12	21:25:55	0.000	0.85
2003/03/12	21:26:00	0.000	0.82
2003/03/12	21:26:05	0.000	0.69
2003/03/12	21:26:10	0.000	0.80
2003/03/12	21:26:15	0.000	0.65
2003/03/12	21:26:20	0.000	0.49
2003/03/12	21:26:25	0.000	0.39
2003/03/12	21:26:30	0.000	0.31
2003/03/12	21:26:35	0.000	0.24
2003/03/12	21:26:40	0.000	0.14
2003/03/12	21:26:45	0.000	0.15
2003/03/12	21:26:50	0.000	0.08
2003/03/12	21:26:55	0.000	0.08
2003/03/12	21:27:00	0.000	0.08
2003/03/12	21:27:05	0.000	0.03
2003/03/12	21:27:10	0.000	0.04
2003/03/12	21:27:15	0.000	0.00
2003/03/12	21:27:20	0.000	0.03
2003/03/12	21:27:25	0.000	0.01
2003/03/12	21:27:30	0.000	0.00
2003/03/12	21:27:35	0.000	0.01
2003/03/12	21:27:40	0.000	0.03
2003/03/12	21:27:45	0.000	0.01
2003/03/12	21:27:50	0.000	-0.02
2003/03/12	21:27:55	0.000	0.03
2003/03/12	21:28:00	0.000	0.00
2003/03/12	21:28:05	0.000	-0.01
2003/03/12	21:28:10	0.000	0.02
2003/03/12	21:28:15	0.000	-0.01
2003/03/12	21:28:20	0.000	0.00
2003/03/12	21:28:25	0.000	-0.01
2003/03/12	21:28:30	0.000	0.01
2003/03/12	21:28:35	0.000	0.01
2003/03/12	21:28:40	0.000	-0.01
2003/03/12	21:28:45	0.000	0.03
2003/03/12	21:28:50	0.000	0.03
2003/03/12	21:28:55	0.000	0.03
2003/03/12	21:29:00	0.000	0.01
2003/03/12	21:29:05	0.000	0.08
2003/03/12	21:29:10	0.000	0.05
2003/03/12	21:29:15	0.000	0.03
2003/03/12	21:29:20	0.000	0.07
2003/03/12	21:29:25	0.000	0.04
2003/03/12	21:29:30	0.000	0.06
2003/03/12	21:29:35	0.000	0.05
2003/03/12	21:29:40	0.000	0.07
2003/03/12	21:29:45	0.000	0.06
2003/03/12	21:29:50	0.000	0.06
2003/03/12	21:29:55	0.000	0.09
2003/03/12	21:30:00	0.000	0.10
2003/03/12	21:30:05	0.000	0.08
2003/03/12	21:30:10	0.000	0.08
2003/03/12	21:30:15	0.000	0.11
2003/03/12	21:30:20	0.000	0.10
2003/03/12	21:30:25	0.000	0.07
2003/03/12	21:30:30	0.000	0.12
2003/03/12	21:30:35	0.000	0.07
2003/03/12	21:30:40	0.000	0.09
2003/03/12	21:30:45	0.000	0.09
2003/03/12	21:30:50	0.000	0.09
2003/03/12	21:30:55	0.000	0.11
2003/03/12	21:31:00	0.000	0.07
2003/03/12	21:31:05	0.000	0.10
2003/03/12	21:31:10	0.000	0.10
2003/03/12	21:31:15	0.000	0.11
2003/03/12	21:31:20	0.000	0.10
2003/03/12	21:31:25	0.000	0.13
2003/03/12	21:31:30	0.000	0.11
2003/03/12	21:31:35	0.000	0.08
2003/03/12	21:31:40	0.000	0.13
2003/03/12	21:31:45	0.000	0.09
2003/03/12	21:31:50	0.000	0.10
2003/03/12	21:31:55	0.000	0.11
2003/03/12	21:32:00	0.000	0.10
2003/03/12	21:32:05	0.000	0.12
2003/03/12	21:32:10	0.000	0.09
2003/03/12	21:32:15	0.000	0.12
2003/03/12	21:32:20	0.000	0.12
2003/03/12	21:32:25	0.000	0.12
2003/03/12	21:32:30	0.000	0.13
2003/03/12	21:32:35	0.000	0.14
2003/03/12	21:32:40	0.000	0.14
2003/03/12	21:32:45	0.000	0.10
2003/03/12	21:32:50	0.000	0.16
2003/03/12	21:32:55	0.000	0.12
2003/03/12	21:33:00	0.000	0.12
2003/03/12	21:33:05	0.000	0.14
2003/03/12	21:33:10	0.000	0.12
2003/03/12	21:33:15	0.000	0.15
2003/03/12	21:33:20	0.000	0.12
2003/03/12	21:33:25	0.000	0.14
2003/03/12	21:33:30	0.000	0.14
2003/03/12	21:33:35	0.000	0.13
2003/03/12	21:33:40	0.000	0.15
2003/03/12	21:33:45	0.000	0.16
2003/03/12	21:33:50	0.000	0.15
2003/03/12	21:33:55	0.000	0.12
2003/03/12	21:34:00	0.000	0.17
2003/03/12	21:34:05	0.000	0.15
2003/03/12	21:34:10	0.000	0.13
2003/03/12	21:34:15	0.000	0.17
2003/03/12	21:34:20	0.000	0.13
2003/03/12	21:34:25	0.000	0.15
2003/03/12	21:34:30	0.000	0.13

0.78

[REDACTED]

0.18

[REDACTED]

2003/03/12 21:34:35 0.000 0.16
 2003/03/12 21:34:40 0.000 0.16
 2003/03/12 21:34:45 0.000 0.14
 2003/03/12 21:34:50 0.000 0.18
 2003/03/12 21:34:55 0.000 0.19
 2003/03/12 21:35:00 0.000 0.18
 2003/03/12 21:35:05 0.000 0.17
 2003/03/12 21:35:10 0.000 0.22
 2003/03/12 21:35:15 0.000 0.20
 2003/03/12 21:35:20 0.000 0.17
 2003/03/12 21:35:25 0.000 0.22
 2003/03/12 21:35:30 0.000 0.18
 2003/03/12 21:35:35 0.000 0.21
 2003/03/12 21:35:40 0.500 0.21
 2003/03/12 21:35:45 0.000 0.22
 2003/03/12 21:35:50 0.000 0.23
 2003/03/12 21:35:55 0.000 0.22
 2003/03/12 21:36:00 0.000 0.25
 2003/03/12 21:36:05 0.000 0.26
 2003/03/12 21:36:10 0.000 0.25
 2003/03/12 21:36:15 0.000 0.25
 2003/03/12 21:36:20 0.000 0.28
 2003/03/12 21:36:25 0.000 0.27
 2003/03/12 21:36:30 0.000 0.26
 2003/03/12 21:36:35 0.000 0.30
 2003/03/12 21:36:40 0.000 0.25
 2003/03/12 21:36:45 0.000 0.28
 2003/03/12 21:36:50 0.000 0.28
 2003/03/12 21:36:55 0.000 0.27
 2003/03/12 21:37:00 0.000 0.30
 2003/03/12 21:37:05 0.000 0.27
 2003/03/12 21:37:10 0.000 0.30
 2003/03/12 21:37:15 0.000 0.30
 2003/03/12 21:37:20 0.000 0.31
 2003/03/12 21:37:25 0.000 0.31
 2003/03/12 21:37:30 0.000 0.33
 2003/03/12 21:37:35 0.000 0.32
 2003/03/12 21:37:40 0.000 0.30
 2003/03/12 21:37:45 0.000 0.35
 2003/03/12 21:37:50 0.000 0.31
 2003/03/12 21:37:55 0.000 0.32
 2003/03/12 21:38:00 0.000 0.34
 2003/03/12 21:38:05 0.000 0.32
 2003/03/12 21:38:10 0.000 0.35
 2003/03/12 21:38:15 0.000 0.33
 2003/03/12 21:38:20 0.000 0.35
 2003/03/12 21:38:25 0.000 0.35
 2003/03/12 21:38:30 0.000 0.35
 2003/03/12 21:38:35 0.000 0.37
 2003/03/12 21:38:40 0.000 0.39
 2003/03/12 21:38:45 0.000 0.38
 2003/03/12 21:38:50 0.000 0.34
 2003/03/12 21:38:55 0.000 0.40
 2003/03/12 21:39:00 0.000 0.38
 2003/03/12 21:39:05 0.000 0.38
 2003/03/12 21:39:10 0.000 0.39
 2003/03/12 21:39:15 0.000 0.37
 2003/03/12 21:39:20 0.000 0.38
 2003/03/12 21:39:25 0.000 0.37
 2003/03/12 21:39:30 0.000 0.40
 2003/03/12 21:39:35 0.000 0.40
 2003/03/12 21:39:40 0.000 0.39
 2003/03/12 21:39:45 0.000 0.40
 2003/03/12 21:39:50 0.000 0.43
 2003/03/12 21:39:55 0.000 0.41
 2003/03/12 21:40:00 0.000 0.39
 2003/03/12 21:40:05 0.000 0.44
 2003/03/12 21:40:10 0.000 0.41
 2003/03/12 21:40:15 0.000 0.40
 2003/03/12 21:40:20 0.000 0.43
 2003/03/12 21:40:25 0.000 0.40
 2003/03/12 21:40:30 0.000 0.43
 2003/03/12 21:40:35 0.000 0.42
 2003/03/12 21:40:40 0.000 0.44
 2003/03/12 21:40:45 0.000 0.45
 2003/03/12 21:40:50 0.000 0.43
 2003/03/12 21:40:55 0.000 0.47
 2003/03/12 21:41:00 0.000 0.47
 2003/03/12 21:41:05 0.000 0.46
 2003/03/12 21:41:10 0.000 0.44
 2003/03/12 21:41:15 0.000 0.46
 2003/03/12 21:41:20 0.000 0.47
 2003/03/12 21:41:25 0.000 0.44
 2003/03/12 21:41:30 0.000 0.46
 2003/03/12 21:41:35 0.000 0.45
 2003/03/12 21:41:40 0.000 0.47
 2003/03/12 21:41:45 0.000 0.47
 2003/03/12 21:41:50 0.000 0.46
 2003/03/12 21:41:55 0.000 0.49
 2003/03/12 21:42:00 0.000 0.47
 2003/03/12 21:42:05 0.000 0.51
 2003/03/12 21:42:10 0.000 0.51
 2003/03/12 21:42:15 0.000 0.51
 2003/03/12 21:42:20 0.000 0.51
 2003/03/12 21:42:25 0.000 0.58
 2003/03/12 21:42:30 0.000 0.55
 2003/03/12 21:42:35 0.000 0.53
 2003/03/12 21:42:40 0.000 0.56
 2003/03/12 21:42:45 0.000 0.53
 2003/03/12 21:42:50 0.000 0.54
 2003/03/12 21:42:55 0.000 0.54
 2003/03/12 21:43:00 0.000 0.53
 2003/03/12 21:43:05 0.000 0.56
 2003/03/12 21:43:10 0.000 0.52
 2003/03/12 21:43:15 0.000 0.54
 2003/03/12 21:43:20 0.000 0.55
 2003/03/12 21:43:25 0.000 0.55
 2003/03/12 21:43:30 0.000 0.51
 2003/03/12 21:43:35 0.000 0.44
 2003/03/12 21:43:40 0.000 0.33
 2003/03/12 21:43:45 0.000 0.22
 2003/03/12 21:43:50 0.000 0.21
 2003/03/12 21:43:55 0.000 0.12
 2003/03/12 21:44:00 0.000 0.09
 2003/03/12 21:44:05 0.000 0.08
 2003/03/12 21:44:10 0.000 0.05
 2003/03/12 21:44:15 0.000 0.11
 2003/03/12 21:44:20 0.000 0.15
 2003/03/12 21:44:25 0.000 0.22
 2003/03/12 21:44:30 0.000 0.21
 2003/03/12 21:44:35 0.000 0.17
 2003/03/12 21:44:40 0.000 0.15
 2003/03/12 21:44:45 0.000 0.14
 2003/03/12 21:44:50 0.000 0.10
 2003/03/12 21:44:55 0.000 0.04
 2003/03/12 21:45:00 0.000 0.08
 2003/03/12 21:45:05 0.000 0.03
 2003/03/12 21:45:10 0.000 0.02
 2003/03/12 21:45:15 0.000 0.04
 2003/03/12 21:45:20 0.000 0.00
 2003/03/12 21:45:25 0.000 0.00
 2003/03/12 21:45:30 0.000 -0.01
 2003/03/12 21:45:35 0.000 0.01
 2003/03/12 21:45:40 0.000 0.01

0.12

XXXXXXXXXXXXXXXXXXXX

0.30

XXXXXXXXXXXXXXXXXXXX

0.89

XXXXXXXXXXXXXXXXXXXX

2003/03/12	21:45:45	0.000	0.00
2003/03/12	21:45:50	0.000	0.02
2003/03/12	21:45:55	0.000	0.04
2003/03/12	21:46:00	0.000	0.03
2003/03/12	21:46:05	0.000	0.01
2003/03/12	21:46:10	0.000	0.08
2003/03/12	21:46:15	0.000	0.03
2003/03/12	21:46:20	0.000	0.02
2003/03/12	21:46:25	0.000	0.05
2003/03/12	21:46:30	0.000	0.02
2003/03/12	21:46:35	0.000	0.05
2003/03/12	21:46:40	0.000	0.04
2003/03/12	21:46:45	0.000	0.08
2003/03/12	21:46:50	0.000	0.08
2003/03/12	21:46:55	0.000	0.07
2003/03/12	21:47:00	0.000	0.11
2003/03/12	21:47:05	0.000	0.12
2003/03/12	21:47:10	0.000	0.11
2003/03/12	21:47:15	0.000	0.10
2003/03/12	21:47:20	0.000	0.16
2003/03/12	21:47:25	0.000	0.14
2003/03/12	21:47:30	0.000	0.12
2003/03/12	21:47:35	0.000	0.16
2003/03/12	21:47:40	0.000	0.12
2003/03/12	21:47:45	0.000	0.16
2003/03/12	21:47:50	0.000	0.14
2003/03/12	21:47:55	0.000	0.16
2003/03/12	21:48:00	0.000	0.16
2003/03/12	21:48:05	0.000	0.16
2003/03/12	21:48:10	0.000	0.18
2003/03/12	21:48:15	0.000	0.19
2003/03/12	21:48:20	0.000	0.19
2003/03/12	21:48:25	0.000	0.18
2003/03/12	21:48:30	0.000	0.21
2003/03/12	21:48:35	0.000	0.19
2003/03/12	21:48:40	0.000	0.17
2003/03/12	21:48:45	0.000	0.22
2003/03/12	21:48:50	0.000	0.17
2003/03/12	21:48:55	0.000	0.20
2003/03/12	21:49:00	0.000	0.20
2003/03/12	21:49:05	0.000	0.20
2003/03/12	21:49:10	0.000	0.22
2003/03/12	21:49:15	0.000	0.19
2003/03/12	21:49:20	0.000	0.23
2003/03/12	21:49:25	0.000	0.23
2003/03/12	21:49:30	0.000	0.24
2003/03/12	21:49:35	0.000	0.24
2003/03/12	21:49:40	0.000	0.26
2003/03/12	21:49:45	0.000	0.24
2003/03/12	21:49:50	0.000	0.23
2003/03/12	21:49:55	0.000	0.28
2003/03/12	21:50:00	0.000	0.23
2003/03/12	21:50:05	0.000	0.26
2003/03/12	21:50:10	0.000	0.27
2003/03/12	21:50:15	0.000	0.26
2003/03/12	21:50:20	0.000	0.29
2003/03/12	21:50:25	0.000	0.28
2003/03/12	21:50:30	0.000	0.29
2003/03/12	21:50:35	0.000	0.29
2003/03/12	21:50:40	0.000	0.29
2003/03/12	21:50:45	0.000	0.31
2003/03/12	21:50:50	0.000	0.33
2003/03/12	21:50:55	0.000	0.33
2003/03/12	21:51:00	0.000	0.30
2003/03/12	21:51:05	0.000	0.35
2003/03/12	21:51:10	0.000	0.32
2003/03/12	21:51:15	0.000	0.33
2003/03/12	21:51:20	0.000	0.38
2003/03/12	21:51:25	0.000	0.34
2003/03/12	21:51:30	0.000	0.38
2003/03/12	21:51:35	0.000	0.35
2003/03/12	21:51:40	0.000	0.38
2003/03/12	21:51:45	0.000	0.39
2003/03/12	21:51:50	0.000	0.38
2003/03/12	21:51:55	0.000	0.40
2003/03/12	21:52:00	0.000	0.43
2003/03/12	21:52:05	0.000	0.42
2003/03/12	21:52:10	0.000	0.40
2003/03/12	21:52:15	0.000	0.47
2003/03/12	21:52:20	0.000	0.45
2003/03/12	21:52:25	0.000	0.44
2003/03/12	21:52:30	0.000	0.48
2003/03/12	21:52:35	0.000	0.46
2003/03/12	21:52:40	0.000	0.47
2003/03/12	21:52:45	0.000	0.47
2003/03/12	21:52:50	0.000	0.60
2003/03/12	21:52:55	0.000	0.61
2003/03/12	21:53:00	0.000	0.60
2003/03/12	21:53:05	0.000	0.64
2003/03/12	21:53:10	0.000	0.68
2003/03/12	21:53:15	0.000	0.64
2003/03/12	21:53:20	0.000	0.64
2003/03/12	21:53:25	0.000	0.69
2003/03/12	21:53:30	0.000	0.68
2003/03/12	21:53:35	0.000	0.68
2003/03/12	21:53:40	0.000	0.61
2003/03/12	21:53:45	0.000	0.67
2003/03/12	21:53:50	0.000	0.60
2003/03/12	21:53:55	0.000	0.69
2003/03/12	21:54:00	0.000	0.61
2003/03/12	21:54:05	0.000	0.63
2003/03/12	21:54:10	0.000	0.62
2003/03/12	21:54:15	0.000	0.67
2003/03/12	21:54:20	0.000	0.68
2003/03/12	21:54:25	0.000	0.68
2003/03/12	21:54:30	0.000	0.67
2003/03/12	21:54:35	0.000	0.72
2003/03/12	21:54:40	0.000	0.71
2003/03/12	21:54:45	0.000	0.68
2003/03/12	21:54:50	0.000	0.74
2003/03/12	21:54:55	0.000	0.69
2003/03/12	21:55:00	0.000	0.78
2003/03/12	21:55:05	0.000	0.73
2003/03/12	21:55:10	0.000	0.78
2003/03/12	21:55:15	0.000	0.78
2003/03/12	21:55:20	0.000	0.74
2003/03/12	21:55:25	0.000	0.78
2003/03/12	21:55:30	0.000	0.78
2003/03/12	21:55:35	0.000	0.79
2003/03/12	21:55:40	0.000	0.60
2003/03/12	21:55:45	0.000	0.63
2003/03/12	21:55:50	0.000	0.61
2003/03/12	21:55:55	0.000	0.79
2003/03/12	21:56:00	0.000	0.64
2003/03/12	21:56:05	0.000	0.61
2003/03/12	21:56:10	0.000	0.63
2003/03/12	21:56:15	0.000	0.65
2003/03/12	21:56:20	0.000	0.64
2003/03/12	21:56:25	0.000	0.68
2003/03/12	21:56:30	0.000	0.64
2003/03/12	21:56:35	0.000	0.67
2003/03/12	21:56:40	0.000	0.68
2003/03/12	21:56:45	0.000	0.68
2003/03/12	21:56:50	0.000	0.68

0.12

RESERVED FOR BANK

0.47

RESERVED FOR BANK

2003/03/12	21:58:55	0.000	0.02
2003/03/12	21:57:00	0.000	0.91
2003/03/12	21:57:06	0.000	0.89
2003/03/12	21:57:10	0.000	0.84
2003/03/12	21:57:15	0.000	0.91
2003/03/12	21:57:20	0.000	0.82
2003/03/12	21:57:25	0.000	0.84
2003/03/12	21:57:30	0.000	0.82
2003/03/12	21:57:35	0.000	0.84
2003/03/12	21:57:40	0.000	0.82
2003/03/12	21:57:45	0.000	0.86
2003/03/12	21:57:50	0.000	0.88
2003/03/12	21:57:55	0.000	0.98
2003/03/12	21:58:00	0.000	0.88
2003/03/12	21:58:05	0.000	1.01
2003/03/12	21:58:10	0.000	1.00
2003/03/12	21:58:15	0.000	0.88
2003/03/12	21:58:20	0.000	1.03
2003/03/12	21:58:25	0.000	1.00
2003/03/12	21:58:30	0.000	0.89
2003/03/12	21:58:35	0.000	1.02
2003/03/12	21:58:40	0.000	0.98
2003/03/12	21:58:45	0.000	1.00
2003/03/12	21:58:50	0.000	0.89
2003/03/12	21:58:55	0.000	1.01
2003/03/12	21:59:00	0.000	1.02
2003/03/12	21:59:05	0.000	1.00
2003/03/12	21:59:10	0.000	1.03
2003/03/12	21:59:15	0.000	1.03
2003/03/12	21:59:20	0.000	1.01
2003/03/12	21:59:25	0.000	0.98
2003/03/12	21:59:30	0.000	1.03
2003/03/12	21:59:35	0.000	1.00
2003/03/12	21:59:40	0.000	0.98
2003/03/12	21:59:45	0.000	1.02
2003/03/12	21:59:50	0.000	0.88
2003/03/12	21:59:55	0.000	1.00
2003/03/12	22:00:00	0.000	0.88
2003/03/12	22:00:05	0.000	1.00
2003/03/12	22:00:10	0.000	1.00
2003/03/12	22:00:15	0.000	0.88
2003/03/12	22:00:20	0.000	1.02
2003/03/12	22:00:25	0.000	1.01
2003/03/12	22:00:30	0.000	0.88
2003/03/12	22:00:35	0.000	0.87
2003/03/12	22:00:40	0.000	1.01
2003/03/12	22:00:45	0.000	0.99
2003/03/12	22:00:50	0.000	0.88
2003/03/12	22:00:55	0.000	0.82
2003/03/12	22:01:00	0.000	0.44
2003/03/12	22:01:05	0.000	0.43
2003/03/12	22:01:10	0.000	0.34
2003/03/12	22:01:15	0.000	0.28
2003/03/12	22:01:20	0.000	0.22
2003/03/12	22:01:25	0.000	0.14
2003/03/12	22:01:30	0.000	0.13
2003/03/12	22:01:35	0.000	0.09
2003/03/12	22:01:40	0.000	0.07
2003/03/12	22:01:45	0.000	0.08
2003/03/12	22:01:50	0.000	0.14
2003/03/12	22:01:55	0.000	0.22
2003/03/12	22:02:00	0.000	0.31
2003/03/12	22:02:05	0.000	0.49
2003/03/12	22:02:10	0.000	0.69
2003/03/12	22:02:15	0.000	0.98
2003/03/12	22:02:20	0.000	0.73
2003/03/12	22:02:25	0.000	0.78
2003/03/12	22:02:30	0.000	0.78
2003/03/12	22:02:35	0.000	0.67
2003/03/12	22:02:40	0.000	0.57
2003/03/12	22:02:45	0.000	0.46
2003/03/12	22:02:50	0.000	0.34
2003/03/12	22:02:55	0.000	0.27
2003/03/12	22:03:00	0.000	0.22
2003/03/12	22:03:05	0.000	0.17
2003/03/12	22:03:10	0.000	0.09
2003/03/12	22:03:15	0.000	0.11
2003/03/12	22:03:20	0.000	0.06
2003/03/12	22:03:25	0.000	0.04
2003/03/12	22:03:30	0.000	0.04
2003/03/12	22:03:35	0.000	0.02
2003/03/12	22:03:40	0.000	0.02
2003/03/12	22:03:45	0.000	0.00
2003/03/12	22:03:50	0.000	0.02
2003/03/12	22:03:55	0.000	0.01
2003/03/12	22:04:00	0.000	0.00
2003/03/12	22:04:05	0.000	0.01
2003/03/12	22:04:10	0.000	0.03
2003/03/12	22:04:15	0.000	0.01
2003/03/12	22:04:20	0.000	-0.02
2003/03/12	22:04:25	0.000	0.03
2003/03/12	22:04:30	0.000	0.00
2003/03/12	22:04:35	0.000	-0.01
2003/03/12	22:04:40	0.000	0.02
2003/03/12	22:04:45	0.000	-0.01
2003/03/12	22:04:50	0.000	0.00
2003/03/12	22:04:55	0.000	-0.02
2003/03/12	22:05:00	0.000	0.01
2003/03/12	22:05:05	0.000	0.01
2003/03/12	22:05:10	0.000	-0.01
2003/03/12	22:05:15	0.000	0.02
2003/03/12	22:05:20	0.000	0.03
2003/03/12	22:05:25	0.000	0.01
2003/03/12	22:05:30	0.000	-0.01
2003/03/12	22:05:35	0.000	0.04
2003/03/12	22:05:40	0.000	0.01
2003/03/12	22:05:45	0.000	-0.01
2003/03/12	22:05:50	0.000	0.02
2003/03/12	22:05:55	0.000	-0.01
2003/03/12	22:06:00	0.000	0.01
2003/03/12	22:06:05	0.000	-0.01
2003/03/12	22:06:10	0.000	0.01
2003/03/12	22:06:15	0.000	0.01
2003/03/12	22:06:20	0.000	-0.01
2003/03/12	22:06:25	0.000	0.02
2003/03/12	22:06:30	0.000	0.02
2003/03/12	22:06:35	0.000	0.01
2003/03/12	22:06:40	0.000	-0.01
2003/03/12	22:06:45	0.000	0.03
2003/03/12	22:06:50	0.000	0.01
2003/03/12	22:06:55	0.000	-0.01
2003/03/12	22:07:00	0.000	0.01
2003/03/12	22:07:05	0.000	-0.02
2003/03/12	22:07:10	0.000	0.01
2003/03/12	22:07:15	0.000	-0.01
2003/03/12	22:07:20	0.000	0.00
2003/03/12	22:07:25	0.000	0.02
2003/03/12	22:07:30	0.000	-0.01
2003/03/12	22:07:35	0.000	0.01
2003/03/12	22:07:40	0.000	0.01
2003/03/12	22:07:45	0.000	0.01
2003/03/12	22:07:50	0.000	0.00
2003/03/12	22:07:55	0.000	0.03
2003/03/12	22:08:00	0.000	0.01

0.91

2003/03/12 21:58:55

0.38

2003/03/12 22:05:00

2003/03/12	22:08:05	0.000	-0.02
2003/03/12	22:08:10	0.000	0.03
2003/03/12	22:08:15	0.000	-0.02
2003/03/12	22:08:20	0.000	0.00
2003/03/12	22:08:25	0.000	0.00
2003/03/12	22:08:30	0.000	0.00
2003/03/12	22:08:35	0.000	0.02
2003/03/12	22:08:40	0.000	-0.02
2003/03/12	22:08:45	0.000	0.01
2003/03/12	22:08:50	0.000	0.00
2003/03/12	22:08:55	0.000	0.01
2003/03/12	22:09:00	0.000	0.01
2003/03/12	22:09:05	0.000	0.03
2003/03/12	22:09:10	0.000	0.02
2003/03/12	22:09:15	0.000	-0.02
2003/03/12	22:09:20	0.000	0.03
2003/03/12	22:09:25	0.000	-0.01
2003/03/12	22:09:30	0.000	0.00
2003/03/12	22:09:35	0.000	0.01
2003/03/12	22:09:40	0.000	-0.01
2003/03/12	22:09:45	0.000	0.01
2003/03/12	22:09:50	0.000	-0.02
2003/03/12	22:09:55	0.000	0.01
2003/03/12	22:10:00	0.000	0.00
2003/03/12	22:10:05	0.000	0.00
2003/03/12	22:10:10	0.000	0.01
2003/03/12	22:10:15	0.000	0.03
2003/03/12	22:10:20	0.000	0.02
2003/03/12	22:10:25	0.000	-0.02
2003/03/12	22:10:30	0.000	0.03
2003/03/12	22:10:35	0.000	0.00
2003/03/12	22:10:40	0.000	0.00
2003/03/12	22:10:45	0.000	0.01
2003/03/12	22:10:50	0.000	-0.01
2003/03/12	22:10:55	0.000	0.00
2003/03/12	22:11:00	0.000	-0.02
2003/03/12	22:11:05	0.000	0.01
2003/03/12	22:11:10	0.000	0.01
2003/03/12	22:11:15	0.000	0.00
2003/03/12	22:11:20	0.000	0.02
2003/03/12	22:11:25	0.000	0.03
2003/03/12	22:11:30	0.000	0.01
2003/03/12	22:11:35	0.000	-0.02
2003/03/12	22:11:40	0.000	0.03
2003/03/12	22:11:45	0.000	0.00
2003/03/12	22:11:50	0.000	-0.01
2003/03/12	22:11:55	0.000	0.02
2003/03/12	22:12:00	0.000	-0.01
2003/03/12	22:12:05	0.000	0.01
2003/03/12	22:12:10	0.000	-0.01
2003/03/12	22:12:15	0.000	0.01
2003/03/12	22:12:20	0.000	0.01
2003/03/12	22:12:25	0.000	-0.01
2003/03/12	22:12:30	0.000	0.02
2003/03/12	22:12:35	0.000	0.02
2003/03/12	22:12:40	0.000	0.01
2003/03/12	22:12:45	0.000	-0.01
2003/03/12	22:12:50	0.000	0.03
2003/03/12	22:12:55	0.000	0.01
2003/03/12	22:13:00	0.000	-0.01
2003/03/12	22:13:05	0.000	0.03
2003/03/12	22:13:10	0.000	-0.02
2003/03/12	22:13:15	0.000	0.01
2003/03/12	22:13:20	0.000	-0.01
2003/03/12	22:13:25	0.000	0.01
2003/03/12	22:13:30	0.000	0.02
2003/03/12	22:13:35	0.000	-0.01
2003/03/12	22:13:40	0.000	0.01
2003/03/12	22:13:45	0.000	0.01
2003/03/12	22:13:50	0.000	0.01
2003/03/12	22:13:55	0.000	-0.01
2003/03/12	22:14:00	0.000	0.03
2003/03/12	22:14:05	0.000	0.01
2003/03/12	22:14:10	0.000	-0.01
2003/03/12	22:14:15	0.000	0.03
2003/03/12	22:14:20	0.000	-0.02
2003/03/12	22:14:25	0.000	0.00
2003/03/12	22:14:30	0.000	0.00
2003/03/12	22:14:35	0.000	0.00
2003/03/12	22:14:40	0.000	0.02
2003/03/12	22:14:45	0.000	-0.01
2003/03/12	22:14:50	0.000	0.01
2003/03/12	22:14:55	0.000	0.01
2003/03/12	22:15:00	0.000	0.01
2003/03/12	22:15:05	0.000	0.00
2003/03/12	22:15:10	0.000	0.03
2003/03/12	22:15:15	0.000	0.02
2003/03/12	22:15:20	0.000	-0.02
2003/03/12	22:15:25	0.000	0.03
2003/03/12	22:15:30	0.000	-0.02
2003/03/12	22:15:35	0.000	0.00
2003/03/12	22:15:40	0.000	0.00
2003/03/12	22:15:45	0.000	-0.01
2003/03/12	22:15:50	0.000	0.01
2003/03/12	22:15:55	0.000	-0.01
2003/03/12	22:16:00	0.000	0.02
2003/03/12	22:16:05	0.000	0.00
2003/03/12	22:16:10	0.000	0.00
2003/03/12	22:16:15	0.000	0.01
2003/03/12	22:16:20	0.000	0.03
2003/03/12	22:16:25	0.000	0.02
2003/03/12	22:16:30	0.000	-0.02
2003/03/12	22:16:35	0.000	0.03
2003/03/12	22:16:40	0.000	-0.01
2003/03/12	22:16:45	0.000	0.00
2003/03/12	22:16:50	0.000	0.01
2003/03/12	22:16:55	0.000	-0.01
2003/03/12	22:17:00	0.000	0.00
2003/03/12	22:17:05	0.000	-0.02
2003/03/12	22:17:10	0.000	0.01
2003/03/12	22:17:15	0.000	0.00
2003/03/12	22:17:20	0.000	0.00
2003/03/12	22:17:25	0.000	0.02
2003/03/12	22:17:30	0.000	0.02
2003/03/12	22:17:35	0.000	0.01
2003/03/12	22:17:40	0.000	-0.02
2003/03/12	22:17:45	0.000	0.03
2003/03/12	22:17:50	0.000	0.00
2003/03/12	22:17:55	0.000	-0.01
2003/03/12	22:18:00	0.000	0.02
2003/03/12	22:18:05	0.000	-0.01
2003/03/12	22:18:10	0.000	0.01
2003/03/12	22:18:15	0.000	-0.02
2003/03/12	22:18:20	0.000	0.01
2003/03/12	22:18:25	0.000	0.01
2003/03/12	22:18:30	0.000	-0.01
2003/03/12	22:18:35	0.000	0.02
2003/03/12	22:18:40	0.000	0.02
2003/03/12	22:18:45	0.000	0.01
2003/03/12	22:18:50	0.000	0.00
2003/03/12	22:18:55	0.000	0.03
2003/03/12	22:19:00	0.000	0.03
2003/03/12	22:19:05	0.000	0.00
2003/03/12	22:19:10	0.000	0.03

0.01

2003/03/12 22:08:05

0.01

2003/03/12 22:14:00

2003/03/12	22:18:16	0.000	-0.02
2003/03/12	22:18:20	0.000	0.01
2003/03/12	22:18:25	0.000	-0.01
2003/03/12	22:18:30	0.000	0.01
2003/03/12	22:18:35	0.000	0.01
2003/03/12	22:18:40	0.000	-0.01
2003/03/12	22:18:45	0.000	0.01
2003/03/12	22:18:50	0.000	0.03
2003/03/12	22:18:55	0.000	0.06
2003/03/12	22:20:00	0.000	0.04
2003/03/12	22:20:05	0.000	0.08
2003/03/12	22:20:10	0.000	0.05
2003/03/12	22:20:15	0.000	0.01
2003/03/12	22:20:20	0.000	0.06
2003/03/12	22:20:25	0.000	-0.01
2003/03/12	22:20:30	0.000	0.00
2003/03/12	22:20:35	0.000	0.00
2003/03/12	22:20:40	0.000	0.00
2003/03/12	22:20:45	0.000	0.02
2003/03/12	22:20:50	0.000	-0.01
2003/03/12	22:20:55	0.000	0.01
2003/03/12	22:21:00	0.000	0.01
2003/03/12	22:21:05	0.000	0.01
2003/03/12	22:21:10	0.000	0.00
2003/03/12	22:21:15	0.000	0.03
2003/03/12	22:21:20	0.000	0.02
2003/03/12	22:21:25	0.000	-0.02
2003/03/12	22:21:30	0.000	0.03
2003/03/12	22:21:35	0.000	-0.02
2003/03/12	22:21:40	0.000	0.00
2003/03/12	22:21:45	0.000	0.00
2003/03/12	22:21:50	0.000	0.00
2003/03/12	22:21:55	0.000	0.01
2003/03/12	22:22:00	0.000	-0.01
2003/03/12	22:22:05	0.000	0.02
2003/03/12	22:22:10	0.000	0.00
2003/03/12	22:22:15	0.000	0.01
2003/03/12	22:22:20	0.000	0.01
2003/03/12	22:22:25	0.000	0.03
2003/03/12	22:22:30	0.000	0.02
2003/03/12	22:22:35	0.000	-0.02
2003/03/12	22:22:40	0.000	0.03
2003/03/12	22:22:45	0.000	-0.01
2003/03/12	22:22:50	0.000	0.00
2003/03/12	22:22:55	0.000	0.01
2003/03/12	22:23:00	0.000	-0.01
2003/03/12	22:23:05	0.000	0.00
2003/03/12	22:23:10	0.000	-0.02
2003/03/12	22:23:15	0.000	0.01
2003/03/12	22:23:20	0.000	0.00
2003/03/12	22:23:25	0.000	0.00
2003/03/12	22:23:30	0.000	0.02
2003/03/12	22:23:35	0.000	0.03
2003/03/12	22:23:40	0.000	0.01
2003/03/12	22:23:45	0.000	-0.02
2003/03/12	22:23:50	0.000	0.03
2003/03/12	22:23:55	0.000	-0.01
2003/03/12	22:24:00	0.000	0.00
2003/03/12	22:24:05	0.000	0.01
2003/03/12	22:24:10	0.000	-0.01
2003/03/12	22:24:15	0.000	0.01
2003/03/12	22:24:20	0.000	-0.02
2003/03/12	22:24:25	0.000	0.01
2003/03/12	22:24:30	0.000	0.01
2003/03/12	22:24:35	0.000	0.00
2003/03/12	22:24:40	0.000	0.02
2003/03/12	22:24:45	0.000	0.03
2003/03/12	22:24:50	0.000	0.01
2003/03/12	22:24:55	0.000	-0.02
2003/03/12	22:25:00	0.000	0.03
2003/03/12	22:25:05	0.000	0.00
2003/03/12	22:25:10	0.000	-0.01
2003/03/12	22:25:15	0.000	0.02
2003/03/12	22:25:20	0.000	-0.01
2003/03/12	22:25:25	0.000	0.01
2003/03/12	22:25:30	0.000	-0.01
2003/03/12	22:25:35	0.000	0.01
2003/03/12	22:25:40	0.000	0.01
2003/03/12	22:25:45	0.000	-0.01
2003/03/12	22:25:50	0.000	0.02
2003/03/12	22:25:55	0.000	0.03
2003/03/12	22:26:00	0.000	0.02
2003/03/12	22:26:05	0.000	-0.01
2003/03/12	22:26:10	0.000	0.04
2003/03/12	22:26:15	0.000	0.01
2003/03/12	22:26:20	0.000	-0.01
2003/03/12	22:26:25	0.000	0.03
2003/03/12	22:26:30	0.000	-0.01
2003/03/12	22:26:35	0.000	0.01
2003/03/12	22:26:40	0.000	0.00
2003/03/12	22:26:45	0.000	0.01
2003/03/12	22:26:50	0.000	0.02
2003/03/12	22:26:55	0.000	-0.01
2003/03/12	22:27:00	0.000	0.02
2003/03/12	22:27:05	0.000	0.03
2003/03/12	22:27:10	0.000	0.02
2003/03/12	22:27:15	0.000	0.00
2003/03/12	22:27:20	0.000	0.04
2003/03/12	22:27:25	0.000	0.03
2003/03/12	22:27:30	0.000	-0.01
2003/03/12	22:27:35	0.000	0.04
2003/03/12	22:27:40	0.000	-0.01
2003/03/12	22:27:45	0.000	0.01
2003/03/12	22:27:50	0.000	0.01
2003/03/12	22:27:55	0.000	0.01
2003/03/12	22:28:00	0.000	0.02
2003/03/12	22:28:05	0.000	0.00
2003/03/12	22:28:10	0.000	0.03
2003/03/12	22:28:15	0.000	0.02
2003/03/12	22:28:20	0.000	0.02
2003/03/12	22:28:25	0.000	0.02
2003/03/12	22:28:30	0.000	0.05
2003/03/12	22:28:35	0.000	0.04
2003/03/12	22:28:40	0.000	0.00
2003/03/12	22:28:45	0.000	0.05
2003/03/12	22:28:50	0.000	0.00
2003/03/12	22:28:55	0.000	0.02
2003/03/12	22:29:00	0.000	0.02
2003/03/12	22:29:05	0.000	0.01
2003/03/12	22:29:10	0.000	0.02
2003/03/12	22:29:15	0.000	-0.00
2003/03/12	22:29:20	0.000	0.03
2003/03/12	22:29:25	0.000	0.02
2003/03/12	22:29:30	0.000	0.02
2003/03/12	22:29:35	0.000	0.03
2003/03/12	22:29:40	0.000	0.05
2003/03/12	22:29:45	0.000	0.03
2003/03/12	22:29:50	0.000	0.00
2003/03/12	22:29:55	0.000	0.05
2003/03/12	22:30:00	0.000	0.01
2003/03/12	22:30:05	0.000	0.02
2003/03/12	22:30:10	0.000	0.03
2003/03/12	22:30:15	0.000	0.01
2003/03/12	22:30:20	0.000	0.03

0.01

2003/03/12 22:18:16

0.01

2003/03/12 22:24:55

0.02

2003/03/12 22:30:00

2003/03/12	22:30:25	0.00	0.00
2003/03/12	22:30:30	0.00	0.03
2003/03/12	22:30:35	0.00	0.03
2003/03/12	22:30:40	0.00	0.02
2003/03/12	22:30:45	0.00	0.04
2003/03/12	22:30:50	0.00	0.04
2003/03/12	22:30:55	0.00	0.03
2003/03/12	22:31:00	0.00	0.01
2003/03/12	22:31:05	0.00	0.06
2003/03/12	22:31:10	0.00	0.02
2003/03/12	22:31:15	0.00	0.01
2003/03/12	22:31:20	0.00	0.04
2003/03/12	22:31:25	0.00	0.01
2003/03/12	22:31:30	0.00	0.04
2003/03/12	22:31:35	0.00	0.01
2003/03/12	22:31:40	0.00	0.03
2003/03/12	22:31:45	0.00	0.03
2003/03/12	22:31:50	0.00	0.01
2003/03/12	22:31:55	0.00	0.04
2003/03/12	22:32:00	0.00	0.05
2003/03/12	22:32:05	0.00	0.04
2003/03/12	22:32:10	0.00	0.01
2003/03/12	22:32:15	0.00	0.06
2003/03/12	22:32:20	0.00	0.03
2003/03/12	22:32:25	0.00	0.02
2003/03/12	22:32:30	0.00	0.05
2003/03/12	22:32:35	0.00	0.01
2003/03/12	22:32:40	0.00	0.03
2003/03/12	22:32:45	0.00	0.02
2003/03/12	22:32:50	0.00	0.04
2003/03/12	22:32:55	0.00	0.04
2003/03/12	22:33:00	0.00	0.02
2003/03/12	22:33:05	0.00	0.04
2003/03/12	22:33:10	0.00	0.05
2003/03/12	22:33:15	0.00	0.04
2003/03/12	22:33:20	0.00	0.02
2003/03/12	22:33:25	0.00	0.07
2003/03/12	22:33:30	0.00	0.05
2003/03/12	22:33:35	0.00	0.02
2003/03/12	22:33:40	0.00	0.06
2003/03/12	22:33:45	0.00	0.01
2003/03/12	22:33:50	0.00	0.04
2003/03/12	22:33:55	0.00	0.03
2003/03/12	22:34:00	0.00	0.04
2003/03/12	22:34:05	0.00	0.05
2003/03/12	22:34:10	0.00	0.03
2003/03/12	22:34:15	0.00	0.06
2003/03/12	22:34:20	0.00	0.06
2003/03/12	22:34:25	0.00	0.06
2003/03/12	22:34:30	0.00	0.04
2003/03/12	22:34:35	0.00	0.06
2003/03/12	22:34:40	0.00	0.06
2003/03/12	22:34:45	0.00	0.03
2003/03/12	22:34:50	0.00	0.06
2003/03/12	22:34:55	0.00	0.03
2003/03/12	22:35:00	0.00	0.05
2003/03/12	22:35:05	0.00	0.06
2003/03/12	22:35:10	0.00	0.05
2003/03/12	22:35:15	0.00	0.06
2003/03/12	22:35:20	0.00	0.04
2003/03/12	22:35:25	0.00	0.07
2003/03/12	22:35:30	0.00	0.07
2003/03/12	22:35:35	0.00	0.07
2003/03/12	22:35:40	0.00	0.07
2003/03/12	22:35:45	0.00	0.09
2003/03/12	22:35:50	0.00	0.06
2003/03/12	22:35:55	0.00	0.05
2003/03/12	22:36:00	0.00	0.10
2003/03/12	22:36:05	0.00	0.06
2003/03/12	22:36:10	0.00	0.06
2003/03/12	22:36:15	0.00	0.09
2003/03/12	22:36:20	0.00	0.08
2003/03/12	22:36:25	0.00	0.10
2003/03/12	22:36:30	0.00	0.07
2003/03/12	22:36:35	0.00	0.10
2003/03/12	22:36:40	0.00	0.10
2003/03/12	22:36:45	0.00	0.10
2003/03/12	22:36:50	0.00	0.11
2003/03/12	22:36:55	0.00	0.13
2003/03/12	22:37:00	0.00	0.11
2003/03/12	22:37:05	0.00	0.09
2003/03/12	22:37:10	0.00	0.14
2003/03/12	22:37:15	0.00	0.09
2003/03/12	22:37:20	0.00	0.07
2003/03/12	22:37:25	0.00	0.07
2003/03/12	22:37:30	0.00	0.03
2003/03/12	22:37:35	0.00	0.04
2003/03/12	22:37:40	0.00	-0.01
2003/03/12	22:37:45	0.00	0.01
2003/03/12	22:37:50	0.00	0.01
2003/03/12	22:37:55	0.00	0.00
2003/03/12	22:38:00	0.00	0.02
2003/03/12	22:38:05	0.00	0.03
2003/03/12	22:38:10	0.00	0.02
2003/03/12	22:38:15	0.00	-0.02
2003/03/12	22:38:20	0.00	0.05
2003/03/12	22:38:25	0.00	0.04
2003/03/12	22:38:30	0.00	0.05
2003/03/12	22:38:35	0.00	0.09
2003/03/12	22:38:40	0.00	0.08
2003/03/12	22:38:45	0.00	0.10
2003/03/12	22:38:50	0.00	0.09
2003/03/12	22:38:55	0.00	0.12
2003/03/12	22:39:00	0.00	0.11
2003/03/12	22:39:05	0.00	0.08
2003/03/12	22:39:10	0.00	0.06
2003/03/12	22:39:15	0.00	0.06
2003/03/12	22:39:20	0.00	0.04
2003/03/12	22:39:25	0.00	0.00
2003/03/12	22:39:30	0.00	0.03
2003/03/12	22:39:35	0.00	0.01
2003/03/12	22:39:40	0.00	-0.01
2003/03/12	22:39:45	0.00	0.02
2003/03/12	22:39:50	0.00	-0.02
2003/03/12	22:39:55	0.00	0.00
2003/03/12	22:40:00	0.00	-0.01
2003/03/12	22:40:05	0.00	0.00
2003/03/12	22:40:10	0.00	0.01
2003/03/12	22:40:15	0.00	-0.01
2003/03/12	22:40:20	0.00	0.02
2003/03/12	22:40:25	0.00	0.01
2003/03/12	22:40:30	0.00	0.01
2003/03/12	22:40:35	0.00	-0.01
2003/03/12	22:40:40	0.00	0.03
2003/03/12	22:40:45	0.00	0.02
2003/03/12	22:40:50	0.00	-0.02
2003/03/12	22:40:55	0.00	0.03
2003/03/12	22:41:00	0.00	-0.02
2003/03/12	22:41:05	0.00	0.01
2003/03/12	22:41:10	0.00	0.00
2003/03/12	22:41:15	0.00	0.00
2003/03/12	22:41:20	0.00	0.00
2003/03/12	22:41:25	0.00	-0.01
2003/03/12	22:41:30	0.00	0.02

0.03

2003/03/12/22:30:25

0.06

2003/03/12/22:40:00

2003/03/12	22:41:35	0.000	0.01
2003/03/12	22:41:40	0.000	0.01
2003/03/12	22:41:45	0.000	0.00
2003/03/12	22:41:50	0.000	0.03
2003/03/12	22:41:55	0.000	0.01
2003/03/12	22:42:00	0.000	-0.02
2003/03/12	22:42:05	0.000	0.03
2003/03/12	22:42:10	0.000	-0.02
2003/03/12	22:42:15	0.000	0.00
2003/03/12	22:42:20	0.000	0.00
2003/03/12	22:42:25	0.000	0.00
2003/03/12	22:42:30	0.000	0.02
2003/03/12	22:42:35	0.000	-0.02
2003/03/12	22:42:40	0.000	0.01
2003/03/12	22:42:45	0.000	0.00
2003/03/12	22:42:50	0.000	0.01
2003/03/12	22:42:55	0.000	0.01
2003/03/12	22:43:00	0.000	0.03
2003/03/12	22:43:05	0.000	0.01
2003/03/12	22:43:10	0.000	-0.02
2003/03/12	22:43:15	0.000	0.03
2003/03/12	22:43:20	0.000	-0.01
2003/03/12	22:43:25	0.000	0.00
2003/03/12	22:43:30	0.000	0.01
2003/03/12	22:43:35	0.000	-0.01
2003/03/12	22:43:40	0.000	0.01
2003/03/12	22:43:45	0.000	-0.02
2003/03/12	22:43:50	0.000	0.01
2003/03/12	22:43:55	0.000	0.01
2003/03/12	22:44:00	0.000	0.00
2003/03/12	22:44:05	0.000	0.01
2003/03/12	22:44:10	0.000	0.03
2003/03/12	22:44:15	0.000	0.02
2003/03/12	22:44:20	0.000	-0.02
2003/03/12	22:44:25	0.000	0.03
2003/03/12	22:44:30	0.000	0.00
2003/03/12	22:44:35	0.000	-0.01
2003/03/12	22:44:40	0.000	0.02
2003/03/12	22:44:45	0.000	-0.01
2003/03/12	22:44:50	0.000	0.01
2003/03/12	22:44:55	0.000	-0.01
2003/03/12	22:45:00	0.000	0.01
2003/03/12	22:45:05	0.000	0.01
2003/03/12	22:45:10	0.000	-0.01
2003/03/12	22:45:15	0.000	0.01
2003/03/12	22:45:20	0.000	0.03
2003/03/12	22:45:25	0.000	0.01
2003/03/12	22:45:30	0.000	-0.02
2003/03/12	22:45:35	0.000	0.03
2003/03/12	22:45:40	0.000	0.01
2003/03/12	22:45:45	0.000	-0.01
2003/03/12	22:45:50	0.000	0.02
2003/03/12	22:45:55	0.000	-0.01
2003/03/12	22:46:00	0.000	0.00
2003/03/12	22:46:05	0.000	-0.01
2003/03/12	22:46:10	0.000	0.01
2003/03/12	22:46:15	0.000	0.01
2003/03/12	22:46:20	0.000	-0.01
2003/03/12	22:46:25	0.000	0.02
2003/03/12	22:46:30	0.000	0.02
2003/03/12	22:46:35	0.000	0.01
2003/03/12	22:46:40	0.000	-0.01
2003/03/12	22:46:45	0.000	0.03
2003/03/12	22:46:50	0.000	0.01
2003/03/12	22:46:55	0.000	-0.02
2003/03/12	22:47:00	0.000	0.03
2003/03/12	22:47:05	0.000	-0.02
2003/03/12	22:47:10	0.000	0.01
2003/03/12	22:47:15	0.000	-0.01
2003/03/12	22:47:20	0.000	0.00
2003/03/12	22:47:25	0.000	0.01
2003/03/12	22:47:30	0.000	-0.01
2003/03/12	22:47:35	0.000	0.02
2003/03/12	22:47:40	0.000	0.01
2003/03/12	22:47:45	0.000	0.01
2003/03/12	22:47:50	0.000	0.00
2003/03/12	22:47:55	0.000	0.03
2003/03/12	22:48:00	0.000	0.01
2003/03/12	22:48:05	0.000	-0.02
2003/03/12	22:48:10	0.000	0.03
2003/03/12	22:48:15	0.000	-0.02
2003/03/12	22:48:20	0.000	0.01
2003/03/12	22:48:25	0.000	0.00
2003/03/12	22:48:30	0.000	0.00
2003/03/12	22:48:35	0.000	-0.02
2003/03/12	22:48:40	0.000	-0.02
2003/03/12	22:48:45	0.000	0.01
2003/03/12	22:48:50	0.000	0.00
2003/03/12	22:48:55	0.000	0.01
2003/03/12	22:49:00	0.000	0.01
2003/03/12	22:49:05	0.000	0.03
2003/03/12	22:49:10	0.000	0.01
2003/03/12	22:49:15	0.000	-0.02
2003/03/12	22:49:20	0.000	0.03
2003/03/12	22:49:25	0.000	-0.01
2003/03/12	22:49:30	0.000	0.00
2003/03/12	22:49:35	0.000	0.01
2003/03/12	22:49:40	0.000	-0.01
2003/03/12	22:49:45	0.000	0.01
2003/03/12	22:49:50	0.000	-0.02
2003/03/12	22:49:55	0.000	0.01
2003/03/12	22:50:00	0.000	0.00
2003/03/12	22:50:05	0.000	0.00
2003/03/12	22:50:10	0.000	0.01
2003/03/12	22:50:15	0.000	0.03
2003/03/12	22:50:20	0.000	0.02
2003/03/12	22:50:25	0.000	-0.02
2003/03/12	22:50:30	0.000	0.03
2003/03/12	22:50:35	0.000	-0.01
2003/03/12	22:50:40	0.000	0.00
2003/03/12	22:50:45	0.000	0.01
2003/03/12	22:50:50	0.000	-0.01
2003/03/12	22:50:55	0.000	0.01
2003/03/12	22:51:00	0.000	-0.02
2003/03/12	22:51:05	0.000	0.01
2003/03/12	22:51:10	0.000	0.01
2003/03/12	22:51:15	0.000	0.00
2003/03/12	22:51:20	0.000	0.01
2003/03/12	22:51:25	0.000	0.03
2003/03/12	22:51:30	0.000	0.01
2003/03/12	22:51:35	0.000	-0.02
2003/03/12	22:51:40	0.000	0.03
2003/03/12	22:51:45	0.000	0.00
2003/03/12	22:51:50	0.000	-0.01
2003/03/12	22:51:55	0.000	0.02
2003/03/12	22:52:00	0.000	-0.01
2003/03/12	22:52:05	0.000	0.00
2003/03/12	22:52:10	0.000	-0.01
2003/03/12	22:52:15	0.000	0.01
2003/03/12	22:52:20	0.000	0.01
2003/03/12	22:52:25	0.000	-0.01
2003/03/12	22:52:30	0.000	0.02
2003/03/12	22:52:35	0.000	0.02
2003/03/12	22:52:40	0.000	0.01

0.00

2003/03/12 22:48:00

0.01

2003/03/12 22:50:00

2003/03/12	22:52:45	0.000	-0.01
2003/03/12	22:52:50	0.000	0.04
2003/03/12	22:52:55	0.000	0.01
2003/03/12	22:53:00	0.000	-0.01
2003/03/12	22:53:05	0.000	0.02
2003/03/12	22:53:10	0.000	-0.01
2003/03/12	22:53:15	0.000	0.01
2003/03/12	22:53:20	0.000	-0.01
2003/03/12	22:53:25	0.000	0.00
2003/03/12	22:53:30	0.000	0.01
2003/03/12	22:53:35	0.000	-0.01
2003/03/12	22:53:40	0.000	0.02
2003/03/12	22:53:45	0.000	0.01
2003/03/12	22:53:50	0.000	0.01
2003/03/12	22:53:55	0.000	-0.01
2003/03/12	22:54:00	0.000	0.03
2003/03/12	22:54:05	0.000	0.01
2003/03/12	22:54:10	0.000	-0.02
2003/03/12	22:54:15	0.000	0.03
2003/03/12	22:54:20	0.000	-0.02
2003/03/12	22:54:25	0.000	0.01
2003/03/12	22:54:30	0.000	0.00
2003/03/12	22:54:35	0.000	0.00
2003/03/12	22:54:40	0.000	0.02
2003/03/12	22:54:45	0.000	-0.02
2003/03/12	22:54:50	0.000	0.01
2003/03/12	22:54:55	0.000	0.01
2003/03/12	22:55:00	0.000	0.01
2003/03/12	22:55:05	0.000	0.00
2003/03/12	22:55:10	0.000	0.03
2003/03/12	22:55:15	0.000	0.01
2003/03/12	22:55:20	0.000	-0.02
2003/03/12	22:55:25	0.000	0.03
2003/03/12	22:55:30	0.000	-0.02
2003/03/12	22:55:35	0.000	0.00
2003/03/12	22:55:40	0.000	0.00
2003/03/12	22:55:45	0.000	-0.01
2003/03/12	22:55:50	0.000	0.02
2003/03/12	22:55:55	0.000	-0.02
2003/03/12	22:56:00	0.000	0.01
2003/03/12	22:56:05	0.000	0.00
2003/03/12	22:56:10	0.000	0.00
2003/03/12	22:56:15	0.000	0.01
2003/03/12	22:56:20	0.000	0.05
2003/03/12	22:56:25	0.000	0.04
2003/03/12	22:56:30	0.000	0.00
2003/03/12	22:56:35	0.000	0.03
2003/03/12	22:56:40	0.000	-0.01
2003/03/12	22:56:45	0.000	0.00
2003/03/12	22:56:50	0.000	0.01
2003/03/12	22:56:55	0.000	-0.01
2003/03/12	22:57:00	0.000	0.01
2003/03/12	22:57:05	0.000	-0.02
2003/03/12	22:57:10	0.000	0.01
2003/03/12	22:57:15	0.000	0.00
2003/03/12	22:57:20	0.000	0.00
2003/03/12	22:57:25	0.000	0.01
2003/03/12	22:57:30	0.000	0.03
2003/03/12	22:57:35	0.000	0.01
2003/03/12	22:57:40	0.000	-0.02
2003/03/12	22:57:45	0.000	0.03
2003/03/12	22:57:50	0.000	0.00
2003/03/12	22:57:55	0.000	-0.01
2003/03/12	22:58:00	0.000	0.02
2003/03/12	22:58:05	0.000	-0.01
2003/03/12	22:58:10	0.000	0.00
2003/03/12	22:58:15	0.000	-0.02
2003/03/12	22:58:20	0.000	0.01
2003/03/12	22:58:25	0.000	0.01
2003/03/12	22:58:30	0.000	-0.01
2003/03/12	22:58:35	0.000	0.02
2003/03/12	22:58:40	0.000	0.02
2003/03/12	22:58:45	0.000	0.01
2003/03/12	22:58:50	0.000	-0.01
2003/03/12	22:58:55	0.000	0.04
2003/03/12	22:59:00	0.000	0.01
2003/03/12	22:59:05	0.000	-0.01
2003/03/12	22:59:10	0.000	0.02
2003/03/12	22:59:15	0.000	-0.01
2003/03/12	22:59:20	0.000	0.01
2003/03/12	22:59:25	0.000	-0.01
2003/03/12	22:59:30	0.000	0.01
2003/03/12	22:59:35	0.000	0.01
2003/03/12	22:59:40	0.000	-0.01
2003/03/12	22:59:45	0.000	0.02
2003/03/12	22:59:50	0.000	0.02
2003/03/12	22:59:55	0.000	0.01
2003/03/12	23:00:00	0.000	-0.01
2003/03/12	23:00:05	0.000	0.03
2003/03/12	23:00:10	0.000	0.01
2003/03/12	23:00:15	0.000	-0.01
2003/03/12	23:00:20	0.000	0.03
2003/03/12	23:00:25	0.000	-0.02
2003/03/12	23:00:30	0.000	0.01
2003/03/12	23:00:35	0.000	-0.01
2003/03/12	23:00:40	0.000	0.00
2003/03/12	23:00:45	0.000	0.02
2003/03/12	23:00:50	0.000	-0.01
2003/03/12	23:00:55	0.000	0.01
2003/03/12	23:01:00	0.000	0.01
2003/03/12	23:01:05	0.000	0.01
2003/03/12	23:01:10	0.000	0.00
2003/03/12	23:01:15	0.000	0.03
2003/03/12	23:01:20	0.000	0.01
2003/03/12	23:01:25	0.000	-0.02
2003/03/12	23:01:30	0.000	0.03
2003/03/12	23:01:35	0.000	-0.02
2003/03/12	23:01:40	0.000	0.00
2003/03/12	23:01:45	0.000	0.00
2003/03/12	23:01:50	0.000	0.00
2003/03/12	23:01:55	0.000	0.02
2003/03/12	23:02:00	0.000	-0.02
2003/03/12	23:02:05	0.000	0.01
2003/03/12	23:02:10	0.000	0.01
2003/03/12	23:02:15	0.000	0.01
2003/03/12	23:02:20	0.000	0.01
2003/03/12	23:02:25	0.000	0.03
2003/03/12	23:02:30	0.000	0.02
2003/03/12	23:02:35	0.000	-0.02
2003/03/12	23:02:40	0.000	0.03
2003/03/12	23:02:45	0.000	-0.01
2003/03/12	23:02:50	0.000	0.00
2003/03/12	23:02:55	0.000	0.01
2003/03/12	23:03:00	0.000	-0.01
2003/03/12	23:03:05	0.000	0.01
2003/03/12	23:03:10	0.000	-0.02
2003/03/12	23:03:15	0.000	0.01
2003/03/12	23:03:20	0.000	0.00
2003/03/12	23:03:25	0.000	0.00
2003/03/12	23:03:30	0.000	0.01
2003/03/12	23:03:35	0.000	0.03
2003/03/12	23:03:40	0.000	0.02
2003/03/12	23:03:45	0.000	-0.02
2003/03/12	23:03:50	0.000	0.03

0.01

20030312T00:00:00

0.01

20030312T00:00:00

2003/03/12	23:03:55	0.000	-0.01
2003/03/12	23:04:00	0.000	0.00
2003/03/12	23:04:05	0.000	0.01
2003/03/12	23:04:10	0.000	-0.01
2003/03/12	23:04:15	0.000	0.00
2003/03/12	23:04:20	0.000	-0.02
2003/03/12	23:04:25	0.000	0.01
2003/03/12	23:04:30	0.000	0.01
2003/03/12	23:04:35	0.000	0.00
2003/03/12	23:04:40	0.000	0.02
2003/03/12	23:04:45	0.000	0.03
2003/03/12	23:04:50	0.000	0.01
2003/03/12	23:04:55	0.000	-0.02
2003/03/12	23:05:00	0.000	0.04
2003/03/12	23:05:05	0.000	0.00
2003/03/12	23:05:10	0.000	-0.01
2003/03/12	23:05:15	0.000	0.02
2003/03/12	23:05:20	0.000	-0.01
2003/03/12	23:05:25	0.000	0.01
2003/03/12	23:05:30	0.000	-0.02
2003/03/12	23:05:35	0.000	0.01
2003/03/12	23:05:40	0.000	0.01
2003/03/12	23:05:45	0.000	-0.01
2003/03/12	23:05:50	0.000	0.02
2003/03/12	23:05:55	0.000	0.02
2003/03/12	23:06:00	0.000	0.01
2003/03/12	23:06:05	0.000	-0.01
2003/03/12	23:06:10	0.000	0.03
2003/03/12	23:06:15	0.000	0.01
2003/03/12	23:06:20	0.000	-0.01
2003/03/12	23:06:25	0.000	0.03
2003/03/12	23:06:30	0.000	-0.02
2003/03/12	23:06:35	0.000	0.01
2003/03/12	23:06:40	0.000	-0.01
2003/03/12	23:06:45	0.000	0.01
2003/03/12	23:06:50	0.000	0.02
2003/03/12	23:06:55	0.000	-0.01
2003/03/12	23:07:00	0.000	0.01
2003/03/12	23:07:05	0.000	0.02
2003/03/12	23:07:10	0.000	0.01
2003/03/12	23:07:15	0.000	-0.01
2003/03/12	23:07:20	0.000	0.03
2003/03/12	23:07:25	0.000	0.01
2003/03/12	23:07:30	0.000	-0.01
2003/03/12	23:07:35	0.000	0.03
2003/03/12	23:07:40	0.000	-0.02
2003/03/12	23:07:45	0.000	0.00
2003/03/12	23:07:50	0.000	0.00
2003/03/12	23:07:55	0.000	0.00
2003/03/12	23:08:00	0.000	0.02
2003/03/12	23:08:05	0.000	-0.02
2003/03/12	23:08:10	0.000	0.01
2003/03/12	23:08:15	0.000	0.01
2003/03/12	23:08:20	0.000	0.01
2003/03/12	23:08:25	0.000	0.00
2003/03/12	23:08:30	0.000	0.03
2003/03/12	23:08:35	0.000	0.02
2003/03/12	23:08:40	0.000	-0.02
2003/03/12	23:08:45	0.000	0.03
2003/03/12	23:08:50	0.000	-0.02
2003/03/12	23:08:55	0.000	0.00
2003/03/12	23:09:00	0.000	0.01
2003/03/12	23:09:05	0.000	-0.01
2003/03/12	23:09:10	0.000	0.01
2003/03/12	23:09:15	0.000	-0.02
2003/03/12	23:09:20	0.000	0.02
2003/03/12	23:09:25	0.000	0.00
2003/03/12	23:09:30	0.000	0.00
2003/03/12	23:09:35	0.000	0.01
2003/03/12	23:09:40	0.000	0.04
2003/03/12	23:09:45	0.000	0.03
2003/03/12	23:09:50	0.000	-0.01
2003/03/12	23:09:55	0.000	0.04
2003/03/12	23:10:00	0.000	0.01
2003/03/12	23:10:05	0.000	0.01
2003/03/12	23:10:10	0.000	0.03
2003/03/12	23:10:15	0.000	0.01
2003/03/12	23:10:20	0.000	0.02
2003/03/12	23:10:25	0.000	0.00
2003/03/12	23:10:30	0.000	0.03
2003/03/12	23:10:35	0.000	0.03
2003/03/12	23:10:40	0.000	0.02
2003/03/12	23:10:45	0.000	0.05
2003/03/12	23:10:50	0.000	0.05
2003/03/12	23:10:55	0.000	0.04
2003/03/12	23:11:00	0.000	0.01
2003/03/12	23:11:05	0.000	0.07
2003/03/12	23:11:10	0.000	0.03
2003/03/12	23:11:15	0.000	0.03
2003/03/12	23:11:20	0.000	0.03
2003/03/12	23:11:25	0.000	0.03
2003/03/12	23:11:30	0.000	0.05
2003/03/12	23:11:35	0.000	0.02
2003/03/12	23:11:40	0.000	0.05
2003/03/12	23:11:45	0.000	0.05
2003/03/12	23:11:50	0.000	0.03
2003/03/12	23:11:55	0.000	0.03
2003/03/12	23:12:00	0.000	0.03
2003/03/12	23:12:05	0.000	0.05
2003/03/12	23:12:10	0.000	0.03
2003/03/12	23:12:15	0.000	0.03
2003/03/12	23:12:20	0.000	0.06
2003/03/12	23:12:25	0.000	0.04
2003/03/12	23:12:30	0.000	0.07
2003/03/12	23:12:35	0.000	0.03
2003/03/12	23:12:40	0.000	0.03
2003/03/12	23:12:45	0.000	0.05
2003/03/12	23:12:50	0.000	0.07
2003/03/12	23:12:55	0.000	0.03
2003/03/12	23:13:00	0.000	0.03
2003/03/12	23:13:05	0.000	0.03
2003/03/12	23:13:10	0.000	0.03
2003/03/12	23:13:15	0.000	0.03
2003/03/12	23:13:20	0.000	0.03
2003/03/12	23:13:25	0.000	0.10
2003/03/12	23:13:30	0.000	0.03
2003/03/12	23:13:35	0.000	0.03
2003/03/12	23:13:40	0.000	0.10
2003/03/12	23:13:45	0.000	0.04
2003/03/12	23:13:50	0.000	0.03
2003/03/12	23:13:55	0.000	0.03
2003/03/12	23:14:00	0.000	0.01
2003/03/12	23:14:05	0.000	0.02
2003/03/12	23:14:10	0.000	-0.01
2003/03/12	23:14:15	0.000	0.01
2003/03/12	23:14:20	0.000	0.01
2003/03/12	23:14:25	0.000	0.01
2003/03/12	23:14:30	0.000	0.00
2003/03/12	23:14:35	0.000	0.03
2003/03/12	23:14:40	0.000	0.02
2003/03/12	23:14:45	0.000	-0.01
2003/03/12	23:14:50	0.000	0.03
2003/03/12	23:14:55	0.000	0.03
2003/03/12	23:15:00	0.000	0.03

0.00

2003/03/12 23:04:00

0.01

2003/03/12 23:09:00

0.04

2003/03/12 23:09:00

2003/03/12	23:16:05	0.000	0.07
2003/03/12	23:16:10	0.000	0.07
2003/03/12	23:16:15	0.000	0.09
2003/03/12	23:16:20	0.000	0.08
2003/03/12	23:16:25	0.000	0.09
2003/03/12	23:16:30	0.000	0.07
2003/03/12	23:16:35	0.000	0.06
2003/03/12	23:16:40	0.000	0.04
2003/03/12	23:16:45	0.000	0.04
2003/03/12	23:16:50	0.000	0.02
2003/03/12	23:16:55	0.000	-0.02
2003/03/12	23:17:00	0.000	0.03
2003/03/12	23:17:05	0.000	-0.01
2003/03/12	23:17:10	0.000	0.00
2003/03/12	23:17:15	0.000	0.01
2003/03/12	23:17:20	0.000	-0.01
2003/03/12	23:17:25	0.000	0.02
2003/03/12	23:17:30	0.000	-0.01
2003/03/12	23:17:35	0.000	0.01
2003/03/12	23:17:40	0.000	-0.02
2003/03/12	23:17:45	0.000	0.01
2003/03/12	23:17:50	0.000	0.00
2003/03/12	23:17:55	0.000	0.02
2003/03/12	23:18:00	0.000	0.03
2003/03/12	23:18:05	0.000	0.01
2003/03/12	23:18:10	0.000	-0.01
2003/03/12	23:18:15	0.000	0.03
2003/03/12	23:18:20	0.000	0.00
2003/03/12	23:18:25	0.000	-0.01
2003/03/12	23:18:30	0.000	0.02
2003/03/12	23:18:35	0.000	-0.01
2003/03/12	23:18:40	0.000	0.01
2003/03/12	23:18:45	0.000	-0.01
2003/03/12	23:18:50	0.000	0.01
2003/03/12	23:18:55	0.000	0.01
2003/03/12	23:19:00	0.000	-0.01
2003/03/12	23:19:05	0.000	0.01
2003/03/12	23:19:10	0.000	0.02
2003/03/12	23:19:15	0.000	0.01
2003/03/12	23:19:20	0.000	-0.01
2003/03/12	23:19:25	0.000	0.03
2003/03/12	23:19:30	0.000	0.01
2003/03/12	23:19:35	0.000	-0.01
2003/03/12	23:19:40	0.000	0.03
2003/03/12	23:19:45	0.000	-0.02
2003/03/12	23:19:50	0.000	0.00
2003/03/12	23:20:00	0.000	-0.01
2003/03/12	23:20:05	0.000	0.00
2003/03/12	23:20:10	0.000	0.02
2003/03/12	23:20:15	0.000	-0.01
2003/03/12	23:20:20	0.000	0.01
2003/03/12	23:20:25	0.000	0.01
2003/03/12	23:20:30	0.000	0.01
2003/03/12	23:20:35	0.000	0.00
2003/03/12	23:20:40	0.000	0.03
2003/03/12	23:20:45	0.000	0.02
2003/03/12	23:20:50	0.000	-0.02
2003/03/12	23:20:55	0.000	0.03
2003/03/12	23:21:00	0.000	-0.02
2003/03/12	23:21:05	0.000	0.00
2003/03/12	23:21:10	0.000	0.00
2003/03/12	23:21:15	0.000	0.00
2003/03/12	23:21:20	0.000	0.01
2003/03/12	23:21:25	0.000	-0.01
2003/03/12	23:21:30	0.000	0.02
2003/03/12	23:21:35	0.000	0.01
2003/03/12	23:21:40	0.000	0.01
2003/03/12	23:21:45	0.000	0.00
2003/03/12	23:21:50	0.000	0.03
2003/03/12	23:21:55	0.000	0.02
2003/03/12	23:22:00	0.000	-0.02
2003/03/12	23:22:05	0.000	0.03
2003/03/12	23:22:10	0.000	-0.01
2003/03/12	23:22:15	0.000	0.00
2003/03/12	23:22:20	0.000	0.01
2003/03/12	23:22:25	0.000	-0.01
2003/03/12	23:22:30	0.000	0.00
2003/03/12	23:22:35	0.000	-0.02
2003/03/12	23:22:40	0.000	0.01
2003/03/12	23:22:45	0.000	0.00
2003/03/12	23:22:50	0.000	0.00
2003/03/12	23:22:55	0.000	0.02
2003/03/12	23:23:00	0.000	0.03
2003/03/12	23:23:05	0.000	0.01
2003/03/12	23:23:10	0.000	-0.02
2003/03/12	23:23:15	0.000	0.03
2003/03/12	23:23:20	0.000	-0.01
2003/03/12	23:23:25	0.000	0.00
2003/03/12	23:23:30	0.000	0.01
2003/03/12	23:23:35	0.000	-0.01
2003/03/12	23:23:40	0.000	0.01
2003/03/12	23:23:45	0.000	-0.02
2003/03/12	23:23:50	0.000	0.01
2003/03/12	23:23:55	0.000	0.01
2003/03/12	23:24:00	0.000	0.00
2003/03/12	23:24:05	0.000	0.02
2003/03/12	23:24:10	0.000	0.03
2003/03/12	23:24:15	0.000	0.01
2003/03/12	23:24:20	0.000	-0.02
2003/03/12	23:24:25	0.000	0.03
2003/03/12	23:24:30	0.000	0.00
2003/03/12	23:24:35	0.000	-0.01
2003/03/12	23:24:40	0.000	0.02
2003/03/12	23:24:45	0.000	-0.01
2003/03/12	23:24:50	0.000	0.01
2003/03/12	23:24:55	0.000	-0.01
2003/03/12	23:25:00	0.000	0.01
2003/03/12	23:25:05	0.000	0.01
2003/03/12	23:25:10	0.000	-0.01
2003/03/12	23:25:15	0.000	0.01
2003/03/12	23:25:20	0.000	0.02
2003/03/12	23:25:25	0.000	0.01
2003/03/12	23:25:30	0.000	-0.01
2003/03/12	23:25:35	0.000	0.03
2003/03/12	23:25:40	0.000	0.00
2003/03/12	23:25:45	0.000	-0.01
2003/03/12	23:25:50	0.000	0.02
2003/03/12	23:25:55	0.000	-0.02
2003/03/12	23:26:00	0.000	0.00
2003/03/12	23:26:05	0.000	-0.01
2003/03/12	23:26:10	0.000	0.01

0.01

23:20:00 23:20:05

0.00

23:20:45 23:20:50

2003/03/12	23:26:16	0.000	0.01
2003/03/12	23:26:20	0.000	-0.01
2003/03/12	23:26:25	0.000	0.01
2003/03/12	23:26:30	0.000	0.02
2003/03/12	23:26:35	0.000	0.01
2003/03/12	23:26:40	0.000	-0.01
2003/03/12	23:26:45	0.000	0.03
2003/03/12	23:26:50	0.000	0.02
2003/03/12	23:26:55	0.000	-0.02
2003/03/12	23:27:00	0.000	0.03
2003/03/12	23:27:05	0.000	-0.02
2003/03/12	23:27:10	0.000	0.00
2003/03/12	23:27:15	0.000	0.00
2003/03/12	23:27:20	0.000	0.00
2003/03/12	23:27:25	0.000	0.01
2003/03/12	23:27:30	0.000	-0.01
2003/03/12	23:27:35	0.000	0.02
2003/03/12	23:27:40	0.000	0.01
2003/03/12	23:27:45	0.000	0.01
2003/03/12	23:27:50	0.000	0.00
2003/03/12	23:27:55	0.000	0.03
2003/03/12	23:28:00	0.000	0.02
2003/03/12	23:28:05	0.000	-0.02
2003/03/12	23:28:10	0.000	0.03
2003/03/12	23:28:15	0.000	-0.01
2003/03/12	23:28:20	0.000	0.00
2003/03/12	23:28:25	0.000	0.00
2003/03/12	23:28:30	0.000	-0.01
2003/03/12	23:28:35	0.000	0.00
2003/03/12	23:28:40	0.000	-0.01
2003/03/12	23:28:45	0.000	0.01
2003/03/12	23:28:50	0.000	-0.02
2003/03/12	23:28:55	0.000	0.01
2003/03/12	23:29:00	0.000	0.00
2003/03/12	23:29:05	0.000	0.00
2003/03/12	23:29:10	0.000	0.02
2003/03/12	23:29:15	0.000	0.03
2003/03/12	23:29:20	0.000	-0.01
2003/03/12	23:29:25	0.000	0.00
2003/03/12	23:29:30	0.000	0.01
2003/03/12	23:29:35	0.000	-0.01
2003/03/12	23:29:40	0.000	0.02
2003/03/12	23:29:45	0.000	-0.01
2003/03/12	23:29:50	0.000	0.01
2003/03/12	23:29:55	0.000	-0.02
2003/03/12	23:30:00	0.000	0.00
2003/03/12	23:30:05	0.000	0.00
2003/03/12	23:30:10	0.000	0.02
2003/03/12	23:30:15	0.000	0.03
2003/03/12	23:30:20	0.000	0.01
2003/03/12	23:30:25	0.000	-0.02
2003/03/12	23:30:30	0.000	0.03
2003/03/12	23:30:35	0.000	0.00
2003/03/12	23:30:40	0.000	-0.01
2003/03/12	23:30:45	0.000	0.02
2003/03/12	23:30:50	0.000	-0.01
2003/03/12	23:30:55	0.000	0.01
2003/03/12	23:31:00	0.000	-0.02
2003/03/12	23:31:05	0.000	0.01
2003/03/12	23:31:10	0.000	0.01
2003/03/12	23:31:15	0.000	-0.01
2003/03/12	23:31:20	0.000	0.02
2003/03/12	23:31:25	0.000	0.02
2003/03/12	23:31:30	0.000	0.01
2003/03/12	23:31:35	0.000	-0.02
2003/03/12	23:31:40	0.000	0.03
2003/03/12	23:31:45	0.000	0.00
2003/03/12	23:31:50	0.000	-0.01
2003/03/12	23:31:55	0.000	0.02
2003/03/12	23:32:00	0.000	-0.02
2003/03/12	23:32:05	0.000	0.00
2003/03/12	23:32:10	0.000	-0.01
2003/03/12	23:32:15	0.000	0.01
2003/03/12	23:32:20	0.000	0.01
2003/03/12	23:32:25	0.000	-0.01
2003/03/12	23:32:30	0.000	0.01
2003/03/12	23:32:35	0.000	0.02
2003/03/12	23:32:40	0.000	0.01
2003/03/12	23:32:45	0.000	0.00
2003/03/12	23:32:50	0.000	0.03
2003/03/12	23:32:55	0.000	0.03
2003/03/12	23:33:00	0.000	-0.01
2003/03/12	23:33:05	0.000	0.03
2003/03/12	23:33:10	0.000	-0.02
2003/03/12	23:33:15	0.000	0.00
2003/03/12	23:33:20	0.000	-0.01
2003/03/12	23:33:25	0.000	0.00
2003/03/12	23:33:30	0.000	0.01
2003/03/12	23:33:35	0.000	-0.01
2003/03/12	23:33:40	0.000	0.02
2003/03/12	23:33:45	0.000	0.01
2003/03/12	23:33:50	0.000	0.01
2003/03/12	23:33:55	0.000	0.00
2003/03/12	23:34:00	0.000	0.03
2003/03/12	23:34:05	0.000	0.02
2003/03/12	23:34:10	0.000	-0.02
2003/03/12	23:34:15	0.000	0.03
2003/03/12	23:34:20	0.000	-0.02
2003/03/12	23:34:25	0.000	0.00
2003/03/12	23:34:30	0.000	0.00
2003/03/12	23:34:35	0.000	0.00
2003/03/12	23:34:40	0.000	0.00
2003/03/12	23:34:45	0.000	-0.02
2003/03/12	23:34:50	0.000	0.01
2003/03/12	23:34:55	0.000	0.00
2003/03/12	23:35:00	0.000	0.01
2003/03/12	23:35:05	0.000	0.01
2003/03/12	23:35:10	0.000	0.03
2003/03/12	23:35:15	0.000	0.01
2003/03/12	23:35:20	0.000	-0.02
2003/03/12	23:35:25	0.000	0.03
2003/03/12	23:35:30	0.000	-0.01
2003/03/12	23:35:35	0.000	0.00
2003/03/12	23:35:40	0.000	-0.01
2003/03/12	23:35:45	0.000	-0.01
2003/03/12	23:35:50	0.000	0.02
2003/03/12	23:35:55	0.000	-0.02
2003/03/12	23:36:00	0.000	0.01
2003/03/12	23:36:05	0.000	0.00
2003/03/12	23:36:10	0.000	0.00
2003/03/12	23:36:15	0.000	0.02
2003/03/12	23:36:20	0.000	0.03
2003/03/12	23:36:25	0.000	0.01
2003/03/12	23:36:30	0.000	-0.02
2003/03/12	23:36:35	0.000	0.03
2003/03/12	23:36:40	0.000	-0.01
2003/03/12	23:36:45	0.000	-0.01
2003/03/12	23:36:50	0.000	0.02
2003/03/12	23:36:55	0.000	-0.01
2003/03/12	23:37:00	0.000	0.01
2003/03/12	23:37:05	0.000	-0.02
2003/03/12	23:37:10	0.000	0.01
2003/03/12	23:37:15	0.000	0.01
2003/03/12	23:37:20	0.000	-0.01

0.00

ENTERTAINMENT WEEKLY

0.01

ENTERTAINMENT WEEKLY

2003/03/12	23:37:25	0.000	0.02
2003/03/12	23:37:30	0.000	0.03
2003/03/12	23:37:35	0.000	0.01
2003/03/12	23:37:40	0.000	-0.02
2003/03/12	23:37:45	0.000	0.03
2003/03/12	23:37:50	0.000	0.00
2003/03/12	23:37:55	0.000	-0.01
2003/03/12	23:38:00	0.000	0.02
2003/03/12	23:38:05	0.000	-0.02
2003/03/12	23:38:10	0.000	0.00
2003/03/12	23:38:15	0.000	-0.01
2003/03/12	23:38:20	0.000	0.01
2003/03/12	23:38:25	0.000	0.01
2003/03/12	23:38:30	0.000	-0.01
2003/03/12	23:38:35	0.000	0.01
2003/03/12	23:38:40	0.000	0.02
2003/03/12	23:38:45	0.000	0.01
2003/03/12	23:38:50	0.000	-0.01
2003/03/12	23:38:55	0.000	0.03
2003/03/12	23:39:00	0.000	0.02
2003/03/12	23:39:05	0.000	-0.01
2003/03/12	23:39:10	0.000	0.02
2003/03/12	23:39:15	0.000	-0.02
2003/03/12	23:39:20	0.000	0.00
2003/03/12	23:39:25	0.000	-0.01
2003/03/12	23:39:30	0.000	0.00
2003/03/12	23:39:35	0.000	0.01
2003/03/12	23:39:40	0.000	-0.01
2003/03/12	23:39:45	0.000	0.02
2003/03/12	23:39:50	0.000	0.01
2003/03/12	23:39:55	0.000	0.01
2003/03/12	23:40:00	0.000	0.00
2003/03/12	23:40:05	0.000	0.03
2003/03/12	23:40:10	0.000	0.02
2003/03/12	23:40:15	0.000	-0.02
2003/03/12	23:40:20	0.000	0.03
2003/03/12	23:40:25	0.000	-0.02
2003/03/12	23:40:30	0.000	0.01
2003/03/12	23:40:35	0.000	0.00
2003/03/12	23:40:40	0.000	0.00
2003/03/12	23:40:45	0.000	0.00
2003/03/12	23:40:50	0.000	-0.02
2003/03/12	23:40:55	0.000	0.01
2003/03/12	23:41:00	0.000	0.00
2003/03/12	23:41:05	0.000	0.01
2003/03/12	23:41:10	0.000	0.01
2003/03/12	23:41:15	0.000	0.03
2003/03/12	23:41:20	0.000	0.01
2003/03/12	23:41:25	0.000	-0.02
2003/03/12	23:41:30	0.000	0.03
2003/03/12	23:41:35	0.000	-0.01
2003/03/12	23:41:40	0.000	0.00
2003/03/12	23:41:45	0.000	0.01
2003/03/12	23:41:50	0.000	-0.01
2003/03/12	23:41:55	0.000	0.02
2003/03/12	23:42:00	0.000	-0.02
2003/03/12	23:42:05	0.000	0.01
2003/03/12	23:42:10	0.000	0.00
2003/03/12	23:42:15	0.000	0.00
2003/03/12	23:42:20	0.000	0.02
2003/03/12	23:42:25	0.000	0.03
2003/03/12	23:42:30	0.000	0.01
2003/03/12	23:42:35	0.000	-0.02
2003/03/12	23:42:40	0.000	0.03
2003/03/12	23:42:45	0.000	-0.01
2003/03/12	23:42:50	0.000	-0.01
2003/03/12	23:42:55	0.000	0.02
2003/03/12	23:43:00	0.000	-0.01
2003/03/12	23:43:05	0.000	0.01
2003/03/12	23:43:10	0.000	-0.02
2003/03/12	23:43:15	0.000	0.01
2003/03/12	23:43:20	0.000	0.01
2003/03/12	23:43:25	0.000	0.00
2003/03/12	23:43:30	0.000	0.02
2003/03/12	23:43:35	0.000	0.04
2003/03/12	23:43:40	0.000	0.03
2003/03/12	23:43:45	0.000	-0.01
2003/03/12	23:43:50	0.000	0.04
2003/03/12	23:43:55	0.000	0.01
2003/03/12	23:44:00	0.000	0.00
2003/03/12	23:44:05	0.000	0.03
2003/03/12	23:44:10	0.000	0.00
2003/03/12	23:44:15	0.000	0.02
2003/03/12	23:44:20	0.000	0.01
2003/03/12	23:44:25	0.000	0.03
2003/03/12	23:44:30	0.000	0.03
2003/03/12	23:44:35	0.000	0.01
2003/03/12	23:44:40	0.000	0.03
2003/03/12	23:44:45	0.000	0.05
2003/03/12	23:44:50	0.000	0.03
2003/03/12	23:44:55	0.000	0.01
2003/03/12	23:45:00	0.000	0.06
2003/03/12	23:45:05	0.000	0.04
2003/03/12	23:45:10	0.000	0.02
2003/03/12	23:45:15	0.000	0.06
2003/03/12	23:45:20	0.000	0.02
2003/03/12	23:45:25	0.000	0.04
2003/03/12	23:45:30	0.000	0.03
2003/03/12	23:45:35	0.000	0.04
2003/03/12	23:45:40	0.000	0.06
2003/03/12	23:45:45	0.000	0.03
2003/03/12	23:45:50	0.000	0.06
2003/03/12	23:45:55	0.000	0.05
2003/03/12	23:46:00	0.000	0.05
2003/03/12	23:46:05	0.000	0.04
2003/03/12	23:46:10	0.000	0.07
2003/03/12	23:46:15	0.000	0.06
2003/03/12	23:46:20	0.000	0.02
2003/03/12	23:46:25	0.000	0.07
2003/03/12	23:46:30	0.000	0.03
2003/03/12	23:46:35	0.000	0.05
2003/03/12	23:46:40	0.000	0.05
2003/03/12	23:46:45	0.000	0.06
2003/03/12	23:46:50	0.000	0.06
2003/03/12	23:46:55	0.000	0.03
2003/03/12	23:47:00	0.000	0.06
2003/03/12	23:47:05	0.000	0.06
2003/03/12	23:47:10	0.000	0.06
2003/03/12	23:47:15	0.000	0.06
2003/03/12	23:47:20	0.000	0.09
2003/03/12	23:47:25	0.000	0.07
2003/03/12	23:47:30	0.000	0.04
2003/03/12	23:47:35	0.000	0.09
2003/03/12	23:47:40	0.000	0.05
2003/03/12	23:47:45	0.000	0.07
2003/03/12	23:47:50	0.000	0.08
2003/03/12	23:47:55	0.000	0.07
2003/03/12	23:48:00	0.000	0.09
2003/03/12	23:48:05	0.000	0.06
2003/03/12	23:48:10	0.000	0.09
2003/03/12	23:48:15	0.000	0.09
2003/03/12	23:48:20	0.000	0.09
2003/03/12	23:48:25	0.000	0.10
2003/03/12	23:48:30	0.000	0.11

0.00

5742004177015526

0.01

5742004177015526

2003/03/12 23:48:35 0.000 0.10
2003/03/12 23:48:40 0.000 0.08
2003/03/12 23:48:45 0.000 0.18
2003/03/12 23:48:50 0.000 0.10
2003/03/12 23:48:55 0.000 0.10
2003/03/12 23:49:00 0.000 0.12
2003/03/12 23:49:05 0.000 0.10
2003/03/12 23:49:10 0.000 0.12
2003/03/12 23:49:15 0.000 0.10
2003/03/12 23:49:20 0.000 0.12
2003/03/12 23:49:25 0.000 0.13
2003/03/12 23:49:30 0.000 0.11
2003/03/12 23:49:35 0.000 0.14
2003/03/12 23:49:40 0.000 0.15
2003/03/12 23:49:45 0.000 0.14
2003/03/12 23:49:50 0.000 0.10
2003/03/12 23:49:55 0.000 0.15
2003/03/12 23:50:00 0.000 0.12
2003/03/12 23:50:05 0.000 0.12
2003/03/12 23:50:10 0.000 0.14
2003/03/12 23:50:15 0.000 0.07
2003/03/12 23:50:20 0.000 0.08
2003/03/12 23:50:25 0.000 0.02
2003/03/12 23:50:30 0.000 0.02
2003/03/12 23:50:35 0.000 0.01
2003/03/12 23:50:40 0.000 -0.01
2003/03/12 23:50:45 0.000 0.01
2003/03/12 23:50:50 0.000 0.02
2003/03/12 23:50:55 0.000 0.01
2003/03/12 23:51:00 0.000 -0.01
2003/03/12 23:51:05 0.000 0.04
2003/03/12 23:51:10 0.000 0.01
2003/03/12 23:51:15 0.000 0.02
2003/03/12 23:51:20 0.000 0.08
2003/03/12 23:51:25 0.000 0.08
2003/03/12 23:51:30 0.000 0.12
2003/03/12 23:51:35 0.000 0.12
2003/03/12 23:51:40 0.000 0.14
2003/03/12 23:51:45 0.000 0.15
2003/03/12 23:51:50 0.000 0.12
2003/03/12 23:51:55 0.000 0.14
2003/03/12 23:52:00 0.000 0.12
2003/03/12 23:52:05 0.000 0.06
2003/03/12 23:52:10 0.000 0.03
2003/03/12 23:52:15 0.000 0.05
2003/03/12 23:52:20 0.000 0.02
2003/03/12 23:52:25 0.000 -0.02
2003/03/12 23:52:30 0.000 0.03
2003/03/12 23:52:35 0.000 -0.02
2003/03/12 23:52:40 0.000 0.01
2003/03/12 23:52:45 0.000 0.00
2003/03/12 23:52:50 0.000 0.00
2003/03/12 23:52:55 0.000 0.00
2003/03/12 23:53:00 0.000 -0.02
2003/03/12 23:53:05 0.000 0.02
2003/03/12 23:53:10 0.000 0.00
2003/03/12 23:53:15 0.000 0.01
2003/03/12 23:53:20 0.000 0.01
2003/03/12 23:53:25 0.000 0.03
2003/03/12 23:53:30 0.000 0.01
2003/03/12 23:53:35 0.000 -0.02
2003/03/12 23:53:40 0.000 0.03
2003/03/12 23:53:45 0.000 -0.02
2003/03/12 23:53:50 0.000 0.00
2003/03/12 23:53:55 0.000 0.01
2003/03/12 23:54:00 0.000 -0.01
2003/03/12 23:54:05 0.000 0.02
2003/03/12 23:54:10 0.000 -0.02
2003/03/12 23:54:15 0.000 0.01
2003/03/12 23:54:20 0.000 0.00
2003/03/12 23:54:25 0.000 0.00
2003/03/12 23:54:30 0.000 0.01
2003/03/12 23:54:35 0.000 0.03
2003/03/12 23:54:40 0.000 0.01
2003/03/12 23:54:45 0.000 -0.02
2003/03/12 23:54:50 0.000 0.03
2003/03/12 23:54:55 0.000 -0.01
2003/03/12 23:55:00 0.000 0.00
2003/03/12 23:55:05 0.000 0.01
2003/03/12 23:55:10 0.000 -0.01
2003/03/12 23:55:15 0.000 0.01
2003/03/12 23:55:20 0.000 -0.02
2003/03/12 23:55:25 0.000 0.00
2003/03/12 23:55:30 0.000 -0.01
2003/03/12 23:55:35 0.000 0.01
2003/03/12 23:55:40 0.000 0.01
2003/03/12 23:55:45 0.000 0.03
2003/03/12 23:55:50 0.000 0.02
2003/03/12 23:55:55 0.000 -0.02
2003/03/12 23:56:00 0.000 0.03
2003/03/12 23:56:05 0.000 0.00
2003/03/12 23:56:10 0.000 -0.01
2003/03/12 23:56:15 0.000 0.02
2003/03/12 23:56:20 0.000 -0.01
2003/03/12 23:56:25 0.000 0.00
2003/03/12 23:56:30 0.000 -0.01
2003/03/12 23:56:35 0.000 0.01
2003/03/12 23:56:40 0.000 0.01
2003/03/12 23:56:45 0.000 -0.01
2003/03/12 23:56:50 0.000 0.01
2003/03/12 23:56:55 0.000 0.02
2003/03/12 23:57:00 0.000 0.01
2003/03/12 23:57:05 0.000 -0.01
2003/03/12 23:57:10 0.000 0.03
2003/03/12 23:57:15 0.000 0.01
2003/03/12 23:57:20 0.000 -0.01
2003/03/12 23:57:25 0.000 0.02
2003/03/12 23:57:30 0.000 -0.02
2003/03/12 23:57:35 0.000 0.00
2003/03/12 23:57:40 0.000 -0.01
2003/03/12 23:57:45 0.000 0.00
2003/03/12 23:57:50 0.000 0.01
2003/03/12 23:57:55 0.000 -0.01
2003/03/12 23:58:00 0.000 0.02
2003/03/12 23:58:05 0.000 0.01
2003/03/12 23:58:10 0.000 0.01
2003/03/12 23:58:15 0.000 -0.01
2003/03/12 23:58:20 0.000 0.03
2003/03/12 23:58:25 0.000 0.02
2003/03/12 23:58:30 0.000 -0.02
2003/03/12 23:58:35 0.000 0.03
2003/03/12 23:58:40 0.000 -0.02
2003/03/12 23:58:45 0.000 0.01
2003/03/12 23:58:50 0.000 0.00
2003/03/12 23:58:55 0.000 0.00
2003/03/12 23:59:00 0.000 0.01
2003/03/12 23:59:05 0.000 -0.01
2003/03/12 23:59:10 0.000 0.01
2003/03/12 23:59:15 0.000 0.01
2003/03/12 23:59:20 0.000 0.01
2003/03/12 23:59:25 0.000 0.01
2003/03/12 23:59:30 0.000 0.03
2003/03/12 23:59:35 0.000 0.01
2003/03/12 23:59:40 0.000 -0.01
2003/03/12 23:59:45 0.000 0.01
2003/03/12 23:59:50 0.000 0.00
2003/03/12 23:59:55 0.000 0.00
2003/03/12 24:00:00 0.000 0.01
2003/03/12 23:59:55 0.000 -0.01

0.07

23:50:00 0.000 0.00

0.03

23:50:00 0.000 0.00

2003/03/12	23:59:45	0.000	0.03
2003/03/12	23:59:50	0.000	-0.02
2003/03/12	23:59:55	0.000	0.00
2003/03/13	00:00:00	0.000	0.00
2003/03/13	00:00:05	0.000	0.00
2003/03/13	00:00:10	0.000	0.02
2003/03/13	00:00:15	0.000	-0.02
2003/03/13	00:00:20	0.000	0.01
2003/03/13	00:00:25	0.000	0.00
2003/03/13	00:00:30	0.000	0.01
2003/03/13	00:00:35	0.000	0.01
2003/03/13	00:00:40	0.000	0.03
2003/03/13	00:00:45	0.000	0.01
2003/03/13	00:00:50	0.000	-0.02
2003/03/13	00:00:55	0.000	0.03
2003/03/13	00:01:00	0.000	-0.01
2003/03/13	00:01:05	0.000	0.00
2003/03/13	00:01:10	0.000	0.01
2003/03/13	00:01:15	0.000	-0.01
2003/03/13	00:01:20	0.000	-0.01
2003/03/13	00:01:25	0.000	-0.02
2003/03/13	00:01:30	0.000	0.01
2003/03/13	00:01:35	0.000	0.01
2003/03/13	00:01:40	0.000	0.00
2003/03/13	00:01:45	0.000	0.02
2003/03/13	00:01:50	0.000	0.03
2003/03/13	00:01:55	0.000	0.02
2003/03/13	00:02:00	0.000	-0.02
2003/03/13	00:02:05	0.000	0.03
2003/03/13	00:02:10	0.000	0.00
2003/03/13	00:02:15	0.000	-0.01
2003/03/13	00:02:20	0.000	0.02
2003/03/13	00:02:25	0.000	-0.01
2003/03/13	00:02:30	0.000	0.00
2003/03/13	00:02:35	0.000	-0.01
2003/03/13	00:02:40	0.000	0.01
2003/03/13	00:02:45	0.000	0.01
2003/03/13	00:02:50	0.000	-0.01
2003/03/13	00:02:55	0.000	0.01
2003/03/13	00:03:00	0.000	0.02
2003/03/13	00:03:05	0.000	0.01
2003/03/13	00:03:10	0.000	-0.01
2003/03/13	00:03:15	0.000	0.04
2003/03/13	00:03:20	0.000	0.01
2003/03/13	00:03:25	0.000	-0.01
2003/03/13	00:03:30	0.000	0.02
2003/03/13	00:03:35	0.000	-0.02
2003/03/13	00:03:40	0.000	0.00
2003/03/13	00:03:45	0.000	-0.01
2003/03/13	00:03:50	0.000	0.01
2003/03/13	00:03:55	0.000	0.01
2003/03/13	00:04:00	0.000	-0.01
2003/03/13	00:04:05	0.000	0.02
2003/03/13	00:04:10	0.000	0.01
2003/03/13	00:04:15	0.000	0.01
2003/03/13	00:04:20	0.000	-0.01
2003/03/13	00:04:25	0.000	0.03
2003/03/13	00:04:30	0.000	0.02
2003/03/13	00:04:35	0.000	-0.02
2003/03/13	00:04:40	0.000	0.03
2003/03/13	00:04:45	0.000	-0.02
2003/03/13	00:04:50	0.000	0.01
2003/03/13	00:04:55	0.000	0.00
2003/03/13	00:05:00	0.000	0.00
2003/03/13	00:05:05	0.000	0.01
2003/03/13	00:05:10	0.000	-0.01
2003/03/13	00:05:15	0.000	0.03
2003/03/13	00:05:20	0.000	0.03
2003/03/13	00:05:25	0.000	0.04
2003/03/13	00:05:30	0.000	0.04
2003/03/13	00:05:35	0.000	0.07
2003/03/13	00:05:40	0.000	0.08
2003/03/13	00:05:45	0.000	0.03
2003/03/13	00:05:50	0.000	0.09
2003/03/13	00:05:55	0.000	0.04
2003/03/13	00:06:00	0.000	0.07
2003/03/13	00:06:05	0.000	0.08
2003/03/13	00:06:10	0.000	0.07
2003/03/13	00:06:15	0.000	0.10
2003/03/13	00:06:20	0.000	0.07
2003/03/13	00:06:25	0.000	0.11
2003/03/13	00:06:30	0.000	0.11
2003/03/13	00:06:35	0.000	0.12
2003/03/13	00:06:40	0.000	0.13
2003/03/13	00:06:45	0.000	0.16
2003/03/13	00:06:50	0.000	0.14
2003/03/13	00:06:55	0.000	0.12
2003/03/13	00:07:00	0.000	0.17
2003/03/13	00:07:05	0.000	0.14
2003/03/13	00:07:10	0.000	0.16
2003/03/13	00:07:15	0.000	0.17
2003/03/13	00:07:20	0.000	0.16
2003/03/13	00:07:25	0.000	0.18
2003/03/13	00:07:30	0.000	0.18
2003/03/13	00:07:35	0.000	0.20
2003/03/13	00:07:40	0.000	0.20
2003/03/13	00:07:45	0.000	0.20
2003/03/13	00:07:50	0.000	0.23
2003/03/13	00:07:55	0.000	0.24
2003/03/13	00:08:00	0.000	0.24
2003/03/13	00:08:05	0.000	0.21
2003/03/13	00:08:10	0.000	0.28
2003/03/13	00:08:15	0.000	0.22
2003/03/13	00:08:20	0.000	0.22
2003/03/13	00:08:25	0.000	0.24
2003/03/13	00:08:30	0.000	0.21
2003/03/13	00:08:35	0.000	0.23
2003/03/13	00:08:40	0.000	0.21
2003/03/13	00:08:45	0.000	0.23
2003/03/13	00:08:50	0.000	0.22
2003/03/13	00:08:55	0.000	0.18
2003/03/13	00:09:00	0.000	0.20
2003/03/13	00:09:05	0.000	0.22
2003/03/13	00:09:10	0.000	0.20
2003/03/13	00:09:15	0.000	0.16
2003/03/13	00:09:20	0.000	0.18
2003/03/13	00:09:25	0.000	0.10
2003/03/13	00:09:30	0.000	0.04
2003/03/13	00:09:35	0.000	0.05
2003/03/13	00:09:40	0.000	-0.01
2003/03/13	00:09:45	0.000	0.00
2003/03/13	00:09:50	0.000	-0.01
2003/03/13	00:09:55	0.000	0.00
2003/03/13	00:10:00	0.000	0.01
2003/03/13	00:10:05	0.000	0.01
2003/03/13	00:10:10	0.000	0.08
2003/03/13	00:10:15	0.000	0.09
2003/03/13	00:10:20	0.000	0.08
2003/03/13	00:10:25	0.000	0.04
2003/03/13	00:10:30	0.000	0.07
2003/03/13	00:10:35	0.000	0.04
2003/03/13	00:10:40	0.000	-0.01
2003/03/13	00:10:45	0.000	0.03
2003/03/13	00:10:50	0.000	-0.02

0.00

XXXXXXXXXXXXXXXXXXXX

0.01

XXXXXXXXXXXXXXXXXXXX

0.13

XXXXXXXXXXXXXXXXXXXX

2003/03/13	00:10:55	0.000	0.01
2003/03/13	00:11:00	0.000	0.00
2003/03/13	00:11:05	0.000	0.00
2003/03/13	00:11:10	0.000	0.01
2003/03/13	00:11:15	0.000	-0.01
2003/03/13	00:11:20	0.000	0.02
2003/03/13	00:11:25	0.000	0.01
2003/03/13	00:11:30	0.000	0.01
2003/03/13	00:11:35	0.000	0.00
2003/03/13	00:11:40	0.000	0.03
2003/03/13	00:11:45	0.000	0.01
2003/03/13	00:11:50	0.000	-0.02
2003/03/13	00:11:55	0.000	0.03
2003/03/13	00:12:00	0.000	-0.02
2003/03/13	00:12:05	0.000	0.00
2003/03/13	00:12:10	0.000	0.00
2003/03/13	00:12:15	0.000	0.00
2003/03/13	00:12:20	0.000	0.02
2003/03/13	00:12:25	0.000	-0.02
2003/03/13	00:12:30	0.000	0.01
2003/03/13	00:12:35	0.000	0.00
2003/03/13	00:12:40	0.000	0.01
2003/03/13	00:12:45	0.000	0.01
2003/03/13	00:12:50	0.000	0.03
2003/03/13	00:12:55	0.000	0.02
2003/03/13	00:13:00	0.000	0.01
2003/03/13	00:13:05	0.000	0.07
2003/03/13	00:13:10	0.000	0.03
2003/03/13	00:13:15	0.000	0.05
2003/03/13	00:13:20	0.000	0.07
2003/03/13	00:13:25	0.000	0.06
2003/03/13	00:13:30	0.000	0.08
2003/03/13	00:13:35	0.000	0.05
2003/03/13	00:13:40	0.000	0.09
2003/03/13	00:13:45	0.000	0.09
2003/03/13	00:13:50	0.000	0.08
2003/03/13	00:13:55	0.000	0.10
2003/03/13	00:14:00	0.000	0.11
2003/03/13	00:14:05	0.000	0.10
2003/03/13	00:14:10	0.000	0.07
2003/03/13	00:14:15	0.000	0.12
2003/03/13	00:14:20	0.000	0.09
2003/03/13	00:14:25	0.000	0.09
2003/03/13	00:14:30	0.000	0.11
2003/03/13	00:14:35	0.000	0.08
2003/03/13	00:14:40	0.000	0.10
2003/03/13	00:14:45	0.000	0.09
2003/03/13	00:14:50	0.000	0.11
2003/03/13	00:14:55	0.000	0.11
2003/03/13	00:15:00	0.000	0.09
2003/03/13	00:15:05	0.000	0.12
2003/03/13	00:15:10	0.000	0.13
2003/03/13	00:15:15	0.000	0.12
2003/03/13	00:15:20	0.000	0.09
2003/03/13	00:15:25	0.000	0.14
2003/03/13	00:15:30	0.000	0.12
2003/03/13	00:15:35	0.000	0.10
2003/03/13	00:15:40	0.000	0.13
2003/03/13	00:15:45	0.000	0.08
2003/03/13	00:15:50	0.000	0.11
2003/03/13	00:15:55	0.000	0.10
2003/03/13	00:16:00	0.000	0.12
2003/03/13	00:16:05	0.000	0.13
2003/03/13	00:16:10	0.000	0.10
2003/03/13	00:16:15	0.000	0.13
2003/03/13	00:16:20	0.000	0.13
2003/03/13	00:16:25	0.000	0.12
2003/03/13	00:16:30	0.000	0.11
2003/03/13	00:16:35	0.000	0.15
2003/03/13	00:16:40	0.000	0.13
2003/03/13	00:16:45	0.000	0.10
2003/03/13	00:16:50	0.000	0.14
2003/03/13	00:16:55	0.000	0.10
2003/03/13	00:17:00	0.000	0.12
2003/03/13	00:17:05	0.000	0.11
2003/03/13	00:17:10	0.000	0.12
2003/03/13	00:17:15	0.000	0.12
2003/03/13	00:17:20	0.000	0.10
2003/03/13	00:17:25	0.000	0.13
2003/03/13	00:17:30	0.000	0.13
2003/03/13	00:17:35	0.000	0.12
2003/03/13	00:17:40	0.000	0.12
2003/03/13	00:17:45	0.000	0.15
2003/03/13	00:17:50	0.000	0.13
2003/03/13	00:17:55	0.000	0.10
2003/03/13	00:18:00	0.000	0.15
2003/03/13	00:18:05	0.000	0.10
2003/03/13	00:18:10	0.000	0.12
2003/03/13	00:18:15	0.000	0.12
2003/03/13	00:18:20	0.000	0.12
2003/03/13	00:18:25	0.000	0.14
2003/03/13	00:18:30	0.000	0.10
2003/03/13	00:18:35	0.000	0.13
2003/03/13	00:18:40	0.000	0.13
2003/03/13	00:18:45	0.000	0.13
2003/03/13	00:18:50	0.000	0.13
2003/03/13	00:18:55	0.000	0.15
2003/03/13	00:19:00	0.000	0.12
2003/03/13	00:19:05	0.000	0.10
2003/03/13	00:19:10	0.000	0.15
2003/03/13	00:19:15	0.000	0.10
2003/03/13	00:19:20	0.000	0.12
2003/03/13	00:19:25	0.000	0.13
2003/03/13	00:19:30	0.000	0.11
2003/03/13	00:19:35	0.000	0.13
2003/03/13	00:19:40	0.000	0.10
2003/03/13	00:19:45	0.000	0.13
2003/03/13	00:19:50	0.000	0.13
2003/03/13	00:19:55	0.000	0.12
2003/03/13	00:20:00	0.000	0.13
2003/03/13	00:20:05	0.000	0.14
2003/03/13	00:20:10	0.000	0.13
2003/03/13	00:20:15	0.000	0.10
2003/03/13	00:20:20	0.000	0.15
2003/03/13	00:20:25	0.000	0.11
2003/03/13	00:20:30	0.000	0.10
2003/03/13	00:20:35	0.000	0.13
2003/03/13	00:20:40	0.000	0.11
2003/03/13	00:20:45	0.000	0.12
2003/03/13	00:20:50	0.000	0.10
2003/03/13	00:20:55	0.000	0.12
2003/03/13	00:21:00	0.000	0.12
2003/03/13	00:21:05	0.000	0.11
2003/03/13	00:21:10	0.000	0.12
2003/03/13	00:21:15	0.000	0.14
2003/03/13	00:21:20	0.000	0.13
2003/03/13	00:21:25	0.000	0.10
2003/03/13	00:21:30	0.000	0.15
2003/03/13	00:21:35	0.000	0.12
2003/03/13	00:21:40	0.000	0.10
2003/03/13	00:21:45	0.000	0.13
2003/03/13	00:21:50	0.000	0.09
2003/03/13	00:21:55	0.000	0.11
2003/03/13	00:22:00	0.000	0.09

0.04

Continued on next page

0.12

Continued on next page

2003/03/13	00:22:05	0.000	0.11
2003/03/13	00:22:10	0.000	0.12
2003/03/13	00:22:15	0.000	0.10
2003/03/13	00:22:20	0.000	0.13
2003/03/13	00:22:25	0.000	0.13
2003/03/13	00:22:30	0.000	0.11
2003/03/13	00:22:35	0.000	0.09
2003/03/13	00:22:40	0.000	0.14
2003/03/13	00:22:45	0.000	0.12
2003/03/13	00:22:50	0.000	0.09
2003/03/13	00:22:55	0.000	0.13
2003/03/13	00:23:00	0.000	0.09
2003/03/13	00:23:05	0.000	0.11
2003/03/13	00:23:10	0.000	0.10
2003/03/13	00:23:15	0.000	0.10
2003/03/13	00:23:20	0.000	0.12
2003/03/13	00:23:25	0.000	0.10
2003/03/13	00:23:30	0.000	0.13
2003/03/13	00:23:35	0.000	0.13
2003/03/13	00:23:40	0.000	0.12
2003/03/13	00:23:45	0.000	0.12
2003/03/13	00:23:50	0.000	0.15
2003/03/13	00:23:55	0.000	0.14
2003/03/13	00:24:00	0.000	0.11
2003/03/13	00:24:05	0.000	0.16
2003/03/13	00:24:10	0.000	0.12
2003/03/13	00:24:15	0.000	0.14
2003/03/13	00:24:20	0.000	0.14
2003/03/13	00:24:25	0.000	0.14
2003/03/13	00:24:30	0.000	0.16
2003/03/13	00:24:35	0.000	0.13
2003/03/13	00:24:40	0.000	0.16
2003/03/13	00:24:45	0.000	0.16
2003/03/13	00:24:50	0.000	0.16
2003/03/13	00:24:55	0.000	0.17
2003/03/13	00:25:00	0.000	0.19
2003/03/13	00:25:05	0.000	0.17
2003/03/13	00:25:10	0.000	0.15
2003/03/13	00:25:15	0.000	0.21
2003/03/13	00:25:20	0.000	0.18
2003/03/13	00:25:25	0.000	0.19
2003/03/13	00:25:30	0.000	0.20
2003/03/13	00:25:35	0.000	0.18
2003/03/13	00:25:40	0.000	0.21
2003/03/13	00:25:45	0.000	0.19
2003/03/13	00:25:50	0.000	0.22
2003/03/13	00:25:55	0.000	0.23
2003/03/13	00:26:00	0.000	0.23
2003/03/13	00:26:05	0.000	0.25
2003/03/13	00:26:10	0.000	0.27
2003/03/13	00:26:15	0.000	0.26
2003/03/13	00:26:20	0.000	0.22
2003/03/13	00:26:25	0.000	0.27
2003/03/13	00:26:30	0.000	0.24
2003/03/13	00:26:35	0.000	0.24
2003/03/13	00:26:40	0.000	0.24
2003/03/13	00:26:45	0.000	0.18
2003/03/13	00:26:50	0.000	0.13
2003/03/13	00:26:55	0.000	0.08
2003/03/13	00:27:00	0.000	0.06
2003/03/13	00:27:05	0.000	0.04
2003/03/13	00:27:10	0.000	0.00
2003/03/13	00:27:15	0.000	0.01
2003/03/13	00:27:20	0.000	0.03
2003/03/13	00:27:25	0.000	0.01
2003/03/13	00:27:30	0.000	-0.02
2003/03/13	00:27:35	0.000	0.03
2003/03/13	00:27:40	0.000	0.04
2003/03/13	00:27:45	0.000	0.08
2003/03/13	00:27:50	0.000	0.18
2003/03/13	00:27:55	0.000	0.19
2003/03/13	00:28:00	0.000	0.24
2003/03/13	00:28:05	0.000	0.24
2003/03/13	00:28:10	0.000	0.27
2003/03/13	00:28:15	0.000	0.28
2003/03/13	00:28:20	0.000	0.26
2003/03/13	00:28:25	0.000	0.26
2003/03/13	00:28:30	0.000	0.20
2003/03/13	00:28:35	0.000	0.14
2003/03/13	00:28:40	0.000	0.08
2003/03/13	00:28:45	0.000	0.08
2003/03/13	00:28:50	0.000	0.05
2003/03/13	00:28:55	0.000	0.00
2003/03/13	00:29:00	0.000	0.03
2003/03/13	00:29:05	0.000	-0.02
2003/03/13	00:29:10	0.000	0.01
2003/03/13	00:29:15	0.000	-0.01
2003/03/13	00:29:20	0.000	0.00
2003/03/13	00:29:25	0.000	0.01
2003/03/13	00:29:30	0.000	-0.01
2003/03/13	00:29:35	0.000	0.02
2003/03/13	00:29:40	0.000	0.01
2003/03/13	00:29:45	0.000	0.01
2003/03/13	00:29:50	0.000	0.00
2003/03/13	00:29:55	0.000	0.03
2003/03/13	00:30:00	0.000	0.01
2003/03/13	00:30:05	0.000	0.05
2003/03/13	00:30:10	0.000	0.03
2003/03/13	00:30:15	0.000	-0.02
2003/03/13	00:30:20	0.000	0.00
2003/03/13	00:30:25	0.000	0.00
2003/03/13	00:30:30	0.000	0.00
2003/03/13	00:30:35	0.000	0.02
2003/03/13	00:30:40	0.000	-0.02
2003/03/13	00:30:45	0.000	0.01
2003/03/13	00:30:50	0.000	0.00
2003/03/13	00:30:55	0.000	0.01
2003/03/13	00:31:00	0.000	0.01
2003/03/13	00:31:05	0.000	0.03
2003/03/13	00:31:10	0.000	0.01
2003/03/13	00:31:15	0.000	-0.02
2003/03/13	00:31:20	0.000	0.03
2003/03/13	00:31:25	0.000	-0.01
2003/03/13	00:31:30	0.000	0.01
2003/03/13	00:31:35	0.000	0.03
2003/03/13	00:31:40	0.000	0.02
2003/03/13	00:31:45	0.000	0.05
2003/03/13	00:31:50	0.000	0.03
2003/03/13	00:31:55	0.000	0.06
2003/03/13	00:32:00	0.000	0.06
2003/03/13	00:32:05	0.000	0.05
2003/03/13	00:32:10	0.000	0.08
2003/03/13	00:32:15	0.000	0.10
2003/03/13	00:32:20	0.000	0.09
2003/03/13	00:32:25	0.000	0.08
2003/03/13	00:32:30	0.000	0.11
2003/03/13	00:32:35	0.000	0.08
2003/03/13	00:32:40	0.000	0.08
2003/03/13	00:32:45	0.000	0.10
2003/03/13	00:32:50	0.000	0.07
2003/03/13	00:32:55	0.000	0.09
2003/03/13	00:33:00	0.000	0.07
2003/03/13	00:33:05	0.000	0.10
2003/03/13	00:33:10	0.000	0.10

0.12

RESERVED FOR USE

0.13

RESERVED FOR USE

2003/03/13	00:33:15	0.000	0.08
2003/03/13	00:33:20	0.000	0.10
2003/03/13	00:33:25	0.000	0.12
2003/03/13	00:33:30	0.000	0.10
2003/03/13	00:33:35	0.000	0.07
2003/03/13	00:33:40	0.000	0.12
2003/03/13	00:33:45	0.000	0.10
2003/03/13	00:33:50	0.000	0.07
2003/03/13	00:33:55	0.000	0.11
2003/03/13	00:34:00	0.000	0.07
2003/03/13	00:34:05	0.000	0.09
2003/03/13	00:34:10	0.000	0.08
2003/03/13	00:34:15	0.000	0.10
2003/03/13	00:34:20	0.000	0.10
2003/03/13	00:34:25	0.000	0.08
2003/03/13	00:34:30	0.000	0.12
2003/03/13	00:34:35	0.000	0.12
2003/03/13	00:34:40	0.000	0.10
2003/03/13	00:34:45	0.000	0.09
2003/03/13	00:34:50	0.000	0.13
2003/03/13	00:34:55	0.000	0.11
2003/03/13	00:35:00	0.000	0.08
2003/03/13	00:35:05	0.000	0.13
2003/03/13	00:35:10	0.000	0.08
2003/03/13	00:35:15	0.000	0.11
2003/03/13	00:35:20	0.000	0.09
2003/03/13	00:35:25	0.000	0.10
2003/03/13	00:35:30	0.000	0.11
2003/03/13	00:35:35	0.000	0.09
2003/03/13	00:35:40	0.000	0.12
2003/03/13	00:35:45	0.000	0.12
2003/03/13	00:35:50	0.000	0.11
2003/03/13	00:35:55	0.000	0.11
2003/03/13	00:36:00	0.000	0.14
2003/03/13	00:36:05	0.000	0.12
2003/03/13	00:36:10	0.000	0.09
2003/03/13	00:36:15	0.000	0.13
2003/03/13	00:36:20	0.000	0.09
2003/03/13	00:36:25	0.000	0.10
2003/03/13	00:36:30	0.000	0.10
2003/03/13	00:36:35	0.000	0.09
2003/03/13	00:36:40	0.000	0.12
2003/03/13	00:36:45	0.000	0.08
2003/03/13	00:36:50	0.000	0.11
2003/03/13	00:36:55	0.000	0.11
2003/03/13	00:37:00	0.000	0.10
2003/03/13	00:37:05	0.000	0.11
2003/03/13	00:37:10	0.000	0.13
2003/03/13	00:37:15	0.000	0.10
2003/03/13	00:37:20	0.000	0.08
2003/03/13	00:37:25	0.000	0.13
2003/03/13	00:37:30	0.000	0.08
2003/03/13	00:37:35	0.000	0.09
2003/03/13	00:37:40	0.000	0.11
2003/03/13	00:37:45	0.000	0.09
2003/03/13	00:37:50	0.000	0.11
2003/03/13	00:37:55	0.000	0.08
2003/03/13	00:38:00	0.000	0.10
2003/03/13	00:38:05	0.000	0.10
2003/03/13	00:38:10	0.000	0.09
2003/03/13	00:38:15	0.000	0.11
2003/03/13	00:38:20	0.000	0.12
2003/03/13	00:38:25	0.000	0.11
2003/03/13	00:38:30	0.000	0.07
2003/03/13	00:38:35	0.000	0.13
2003/03/13	00:38:40	0.000	0.09
2003/03/13	00:38:45	0.000	0.09
2003/03/13	00:38:50	0.000	0.11
2003/03/13	00:38:55	0.000	0.08
2003/03/13	00:39:00	0.000	0.10
2003/03/13	00:39:05	0.000	0.08
2003/03/13	00:39:10	0.000	0.11
2003/03/13	00:39:15	0.000	0.10
2003/03/13	00:39:20	0.000	0.08
2003/03/13	00:39:25	0.000	0.10
2003/03/13	00:39:30	0.000	0.12
2003/03/13	00:39:35	0.000	0.10
2003/03/13	00:39:40	0.000	0.07
2003/03/13	00:39:45	0.000	0.13
2003/03/13	00:39:50	0.000	0.10
2003/03/13	00:39:55	0.000	0.08
2003/03/13	00:40:00	0.000	0.11
2003/03/13	00:40:05	0.000	0.08
2003/03/13	00:40:10	0.000	0.09
2003/03/13	00:40:15	0.000	0.07
2003/03/13	00:40:20	0.000	0.09
2003/03/13	00:40:25	0.000	0.10
2003/03/13	00:40:30	0.000	0.08
2003/03/13	00:40:35	0.000	0.11
2003/03/13	00:40:40	0.000	0.11
2003/03/13	00:40:45	0.000	0.09
2003/03/13	00:40:50	0.000	0.08
2003/03/13	00:40:55	0.000	0.12
2003/03/13	00:41:00	0.000	0.10
2003/03/13	00:41:05	0.000	0.07
2003/03/13	00:41:10	0.000	0.11
2003/03/13	00:41:15	0.000	0.07
2003/03/13	00:41:20	0.000	0.09
2003/03/13	00:41:25	0.000	0.08
2003/03/13	00:41:30	0.000	0.09
2003/03/13	00:41:35	0.000	0.09
2003/03/13	00:41:40	0.000	0.07
2003/03/13	00:41:45	0.000	0.10
2003/03/13	00:41:50	0.000	0.10
2003/03/13	00:41:55	0.000	0.10
2003/03/13	00:42:00	0.000	0.09
2003/03/13	00:42:05	0.000	0.12
2003/03/13	00:42:10	0.000	0.10
2003/03/13	00:42:15	0.000	0.07
2003/03/13	00:42:20	0.000	0.12
2003/03/13	00:42:25	0.000	0.07
2003/03/13	00:42:30	0.000	0.09
2003/03/13	00:42:35	0.000	0.09
2003/03/13	00:42:40	0.000	0.09
2003/03/13	00:42:45	0.000	0.11
2003/03/13	00:42:50	0.000	0.08
2003/03/13	00:42:55	0.000	0.11
2003/03/13	00:43:00	0.000	0.11
2003/03/13	00:43:05	0.000	0.10
2003/03/13	00:43:10	0.000	0.11
2003/03/13	00:43:15	0.000	0.13
2003/03/13	00:43:20	0.000	0.11
2003/03/13	00:43:25	0.000	0.09
2003/03/13	00:43:30	0.000	0.14
2003/03/13	00:43:35	0.000	0.10
2003/03/13	00:43:40	0.000	0.11
2003/03/13	00:43:45	0.000	0.12
2003/03/13	00:43:50	0.000	0.10
2003/03/13	00:43:55	0.000	0.13
2003/03/13	00:44:00	0.000	0.10
2003/03/13	00:44:05	0.000	0.13
2003/03/13	00:44:10	0.000	0.13
2003/03/13	00:44:15	0.000	0.13
2003/03/13	00:44:20	0.000	0.15

0.08

00:00:00 00:00:00

0.10

00:00:00 00:00:00

2003/03/13	00:44:25	0.000	0.18
2003/03/13	00:44:30	0.000	0.15
2003/03/13	00:44:35	0.000	0.12
2003/03/13	00:44:40	0.000	0.18
2003/03/13	00:44:45	0.000	0.15
2003/03/13	00:44:50	0.000	0.14
2003/03/13	00:44:55	0.000	0.17
2003/03/13	00:45:00	0.000	0.14
2003/03/13	00:45:05	0.000	0.18
2003/03/13	00:45:10	0.000	0.14
2003/03/13	00:45:15	0.000	0.17
2003/03/13	00:45:20	0.000	0.17
2003/03/13	00:45:25	0.000	0.15
2003/03/13	00:45:30	0.000	0.17
2003/03/13	00:45:35	0.000	0.19
2003/03/13	00:45:40	0.000	0.19
2003/03/13	00:45:45	0.000	0.18
2003/03/13	00:45:50	0.000	0.19
2003/03/13	00:45:55	0.000	0.12
2003/03/13	00:46:00	0.000	0.08
2003/03/13	00:46:05	0.000	0.07
2003/03/13	00:46:10	0.000	0.01
2003/03/13	00:46:15	0.000	0.01
2003/03/13	00:46:20	0.000	-0.01
2003/03/13	00:46:25	0.000	0.01
2003/03/13	00:46:30	0.000	0.02
2003/03/13	00:46:35	0.000	0.03
2003/03/13	00:46:40	0.000	0.09
2003/03/13	00:46:45	0.000	0.10
2003/03/13	00:46:50	0.000	0.09
2003/03/13	00:46:55	0.000	0.07
2003/03/13	00:47:00	0.000	0.11
2003/03/13	00:47:05	0.000	0.08
2003/03/13	00:47:10	0.000	0.05
2003/03/13	00:47:15	0.000	0.09
2003/03/13	00:47:20	0.000	0.04
2003/03/13	00:47:25	0.000	0.09
2003/03/13	00:47:30	0.000	0.04
2003/03/13	00:47:35	0.000	0.03
2003/03/13	00:47:40	0.000	0.02
2003/03/13	00:47:45	0.000	-0.01
2003/03/13	00:47:50	0.000	0.02
2003/03/13	00:47:55	0.000	0.01
2003/03/13	00:48:00	0.000	0.01
2003/03/13	00:48:05	0.000	0.00
2003/03/13	00:48:10	0.000	0.03
2003/03/13	00:48:15	0.000	0.01
2003/03/13	00:48:20	0.000	-0.02
2003/03/13	00:48:25	0.000	0.03
2003/03/13	00:48:30	0.000	-0.02
2003/03/13	00:48:35	0.000	0.00
2003/03/13	00:48:40	0.000	0.00
2003/03/13	00:48:45	0.000	0.00
2003/03/13	00:48:50	0.000	0.02
2003/03/13	00:48:55	0.000	-0.01
2003/03/13	00:49:00	0.000	0.04
2003/03/13	00:49:05	0.000	0.04
2003/03/13	00:49:10	0.000	0.05
2003/03/13	00:49:15	0.000	0.05
2003/03/13	00:49:20	0.000	0.08
2003/03/13	00:49:25	0.000	0.07
2003/03/13	00:49:30	0.000	0.05
2003/03/13	00:49:35	0.000	0.10
2003/03/13	00:49:40	0.000	0.09
2003/03/13	00:49:45	0.000	0.09
2003/03/13	00:49:50	0.000	0.10
2003/03/13	00:49:55	0.000	0.09
2003/03/13	00:50:00	0.000	0.10
2003/03/13	00:50:05	0.000	0.07
2003/03/13	00:50:10	0.000	0.11
2003/03/13	00:50:15	0.000	0.11
2003/03/13	00:50:20	0.000	0.10
2003/03/13	00:50:25	0.000	0.12
2003/03/13	00:50:30	0.000	0.13
2003/03/13	00:50:35	0.000	0.13
2003/03/13	00:50:40	0.000	0.09
2003/03/13	00:50:45	0.000	0.14
2003/03/13	00:50:50	0.000	0.11
2003/03/13	00:50:55	0.000	0.10
2003/03/13	00:51:00	0.000	0.13
2003/03/13	00:51:05	0.000	0.10
2003/03/13	00:51:10	0.000	0.12
2003/03/13	00:51:15	0.000	0.10
2003/03/13	00:51:20	0.000	0.13
2003/03/13	00:51:25	0.000	0.12
2003/03/13	00:51:30	0.000	0.11
2003/03/13	00:51:35	0.000	0.13
2003/03/13	00:51:40	0.000	0.15
2003/03/13	00:51:45	0.000	0.14
2003/03/13	00:51:50	0.000	0.11
2003/03/13	00:51:55	0.000	0.16
2003/03/13	00:52:00	0.000	0.14
2003/03/13	00:52:05	0.000	0.12
2003/03/13	00:52:10	0.000	0.15
2003/03/13	00:52:15	0.000	0.12
2003/03/13	00:52:20	0.000	0.14
2003/03/13	00:52:25	0.000	0.13
2003/03/13	00:52:30	0.000	0.16
2003/03/13	00:52:35	0.000	0.15
2003/03/13	00:52:40	0.000	0.13
2003/03/13	00:52:45	0.000	0.16
2003/03/13	00:52:50	0.000	0.17
2003/03/13	00:52:55	0.000	0.15
2003/03/13	00:53:00	0.000	0.15
2003/03/13	00:53:05	0.000	0.19
2003/03/13	00:53:10	0.000	0.17
2003/03/13	00:53:15	0.000	0.14
2003/03/13	00:53:20	0.000	0.15
2003/03/13	00:53:25	0.000	0.14
2003/03/13	00:53:30	0.000	0.18
2003/03/13	00:53:35	0.000	0.15
2003/03/13	00:53:40	0.000	0.17
2003/03/13	00:53:45	0.000	0.18
2003/03/13	00:53:50	0.000	0.17
2003/03/13	00:53:55	0.000	0.20
2003/03/13	00:54:00	0.000	0.20
2003/03/13	00:54:05	0.000	0.20
2003/03/13	00:54:10	0.000	0.20
2003/03/13	00:54:15	0.000	0.22
2003/03/13	00:54:20	0.000	0.21
2003/03/13	00:54:25	0.000	0.19
2003/03/13	00:54:30	0.000	0.24
2003/03/13	00:54:35	0.000	0.20
2003/03/13	00:54:40	0.000	0.22
2003/03/13	00:54:45	0.000	0.23
2003/03/13	00:54:50	0.000	0.23
2003/03/13	00:54:55	0.000	0.26
2003/03/13	00:55:00	0.000	0.22
2003/03/13	00:55:05	0.000	0.25
2003/03/13	00:55:10	0.000	0.25
2003/03/13	00:55:15	0.000	0.25
2003/03/13	00:55:20	0.000	0.25
2003/03/13	00:55:25	0.000	0.28
2003/03/13	00:55:30	0.000	0.28

0.11

ES20091101000000

0.07

ES20090310000000

0.15

ES20090410000000

2003/03/13	00:53:36	0.000	0.23
2003/03/13	00:53:40	0.000	0.29
2003/03/13	00:53:45	0.000	0.25
2003/03/13	00:53:50	0.000	0.28
2003/03/13	00:53:55	0.000	0.28
2003/03/13	00:53:00	0.000	0.28
2003/03/13	00:53:05	0.000	0.28
2003/03/13	00:53:10	0.000	0.28
2003/03/13	00:53:15	0.000	0.28
2003/03/13	00:53:20	0.000	0.28
2003/03/13	00:53:25	0.000	0.28
2003/03/13	00:53:30	0.000	0.29
2003/03/13	00:53:35	0.000	0.31
2003/03/13	00:53:40	0.000	0.30
2003/03/13	00:53:45	0.000	0.30
2003/03/13	00:53:50	0.000	0.32
2003/03/13	00:53:55	0.000	0.32
2003/03/13	00:54:00	0.000	0.32
2003/03/13	00:54:05	0.000	0.29
2003/03/13	00:54:10	0.000	0.32
2003/03/13	00:54:15	0.000	0.32
2003/03/13	00:54:20	0.000	0.30
2003/03/13	00:54:25	0.000	0.32
2003/03/13	00:54:30	0.000	0.33
2003/03/13	00:54:35	0.000	0.31
2003/03/13	00:54:40	0.000	0.33
2003/03/13	00:54:45	0.000	0.34
2003/03/13	00:54:50	0.000	0.33
2003/03/13	00:54:55	0.000	0.35
2003/03/13	00:55:00	0.000	0.35
2003/03/13	00:55:05	0.000	0.35
2003/03/13	00:55:10	0.000	0.37
2003/03/13	00:55:15	0.000	0.38
2003/03/13	00:55:20	0.000	0.38
2003/03/13	00:55:25	0.000	0.38
2003/03/13	00:55:30	0.000	0.37
2003/03/13	00:55:35	0.000	0.35
2003/03/13	00:55:40	0.000	0.34
2003/03/13	00:55:45	0.000	0.34
2003/03/13	00:55:50	0.000	0.38
2003/03/13	00:55:55	0.000	0.34
2003/03/13	01:00:00	0.000	0.37
2003/03/13	01:00:05	0.000	0.37
2003/03/13	01:00:10	0.000	0.37
2003/03/13	01:00:15	0.000	0.38
2003/03/13	01:00:20	0.000	0.39
2003/03/13	01:00:25	0.000	0.37
2003/03/13	01:00:30	0.000	0.34
2003/03/13	01:00:35	0.000	0.39
2003/03/13	01:00:40	0.000	0.35
2003/03/13	01:00:45	0.000	0.37
2003/03/13	01:00:50	0.000	0.38
2003/03/13	01:00:55	0.000	0.38
2003/03/13	01:01:00	0.000	0.39
2003/03/13	01:01:05	0.000	0.35
2003/03/13	01:01:10	0.000	0.38
2003/03/13	01:01:15	0.000	0.38
2003/03/13	01:01:20	0.000	0.37
2003/03/13	01:01:25	0.000	0.38
2003/03/13	01:01:30	0.000	0.40
2003/03/13	01:01:35	0.000	0.38
2003/03/13	01:01:40	0.000	0.38
2003/03/13	01:01:45	0.000	0.40
2003/03/13	01:01:50	0.000	0.38
2003/03/13	01:01:55	0.000	0.37
2003/03/13	01:02:00	0.000	0.38
2003/03/13	01:02:05	0.000	0.38
2003/03/13	01:02:10	0.000	0.38
2003/03/13	01:02:15	0.000	0.38
2003/03/13	01:02:20	0.000	0.38
2003/03/13	01:02:25	0.000	0.39
2003/03/13	01:02:30	0.000	0.37
2003/03/13	01:02:35	0.000	0.40
2003/03/13	01:02:40	0.000	0.41
2003/03/13	01:02:45	0.000	0.39
2003/03/13	01:02:50	0.000	0.35
2003/03/13	01:02:55	0.000	0.40
2003/03/13	01:03:00	0.000	0.37
2003/03/13	01:03:05	0.000	0.34
2003/03/13	01:03:10	0.000	0.31
2003/03/13	01:03:15	0.000	0.21
2003/03/13	01:03:20	0.000	0.18
2003/03/13	01:03:25	0.000	0.11
2003/03/13	01:03:30	0.000	0.09
2003/03/13	01:03:35	0.000	0.07
2003/03/13	01:03:40	0.000	0.02
2003/03/13	01:03:45	0.000	0.02
2003/03/13	01:03:50	0.000	0.02
2003/03/13	01:03:55	0.000	0.01
2003/03/13	01:04:00	0.000	-0.01
2003/03/13	01:04:05	0.000	0.08
2003/03/13	01:04:10	0.000	0.11
2003/03/13	01:04:15	0.000	0.15
2003/03/13	01:04:20	0.000	0.25
2003/03/13	01:04:25	0.000	0.25
2003/03/13	01:04:30	0.000	0.30
2003/03/13	01:04:35	0.000	0.31
2003/03/13	01:04:40	0.000	0.33
2003/03/13	01:04:45	0.000	0.35
2003/03/13	01:04:50	0.000	0.30
2003/03/13	01:04:55	0.000	0.27
2003/03/13	01:05:00	0.000	0.21
2003/03/13	01:05:05	0.000	0.14
2003/03/13	01:05:10	0.000	0.08
2003/03/13	01:05:15	0.000	0.08
2003/03/13	01:05:20	0.000	0.08
2003/03/13	01:05:25	0.000	0.00
2003/03/13	01:05:30	0.000	0.04
2003/03/13	01:05:35	0.000	-0.02
2003/03/13	01:05:40	0.000	0.01
2003/03/13	01:05:45	0.000	0.00
2003/03/13	01:05:50	0.000	0.00
2003/03/13	01:05:55	0.000	0.00
2003/03/13	01:06:00	0.000	-0.01
2003/03/13	01:06:05	0.000	0.01
2003/03/13	01:06:10	0.000	0.00
2003/03/13	01:06:15	0.000	0.01
2003/03/13	01:06:20	0.000	0.01
2003/03/13	01:06:25	0.000	0.03
2003/03/13	01:06:30	0.000	0.01
2003/03/13	01:06:35	0.000	-0.02
2003/03/13	01:06:40	0.000	0.03

0.31

XXXXXXXXXXXXXXXXXXXX

0.30

XXXXXXXXXXXXXXXXXXXX

2003/03/13	01:02:45	0.000	-0.01
2003/03/13	01:02:50	0.000	0.00
2003/03/13	01:02:55	0.000	0.01
2003/03/13	01:07:00	0.000	-0.01
2003/03/13	01:07:05	0.000	0.02
2003/03/13	01:07:10	0.000	-0.02
2003/03/13	01:07:15	0.000	0.01
2003/03/13	01:07:20	0.000	0.00
2003/03/13	01:07:25	0.000	0.00
2003/03/13	01:07:30	0.000	0.02
2003/03/13	01:07:35	0.000	0.03
2003/03/13	01:07:40	0.000	0.01
2003/03/13	01:07:45	0.000	0.00
2003/03/13	01:07:50	0.000	0.06
2003/03/13	01:07:55	0.000	0.03
2003/03/13	01:08:00	0.000	0.03
2003/03/13	01:08:05	0.000	0.08
2003/03/13	01:08:10	0.000	0.04
2003/03/13	01:08:15	0.000	0.07
2003/03/13	01:08:20	0.000	0.04
2003/03/13	01:08:25	0.000	0.07
2003/03/13	01:08:30	0.000	0.08
2003/03/13	01:08:35	0.000	0.07
2003/03/13	01:08:40	0.000	0.09
2003/03/13	01:08:45	0.000	0.11
2003/03/13	01:08:50	0.000	0.08
2003/03/13	01:08:55	0.000	0.08
2003/03/13	01:09:00	0.000	0.12
2003/03/13	01:09:05	0.000	0.08
2003/03/13	01:09:10	0.000	0.07
2003/03/13	01:09:15	0.000	0.11
2003/03/13	01:09:20	0.000	0.07
2003/03/13	01:09:25	0.000	0.09
2003/03/13	01:09:30	0.000	0.07
2003/03/13	01:09:35	0.000	0.09
2003/03/13	01:09:40	0.000	0.10
2003/03/13	01:09:45	0.000	0.08
2003/03/13	01:09:50	0.000	0.10
2003/03/13	01:09:55	0.000	0.11
2003/03/13	01:10:00	0.000	0.10
2003/03/13	01:10:05	0.000	0.07
2003/03/13	01:10:10	0.000	0.12
2003/03/13	01:10:15	0.000	0.10
2003/03/13	01:10:20	0.000	0.07
2003/03/13	01:10:25	0.000	0.12
2003/03/13	01:10:30	0.000	0.07
2003/03/13	01:10:35	0.000	0.09
2003/03/13	01:10:40	0.000	0.08
2003/03/13	01:10:45	0.000	0.09
2003/03/13	01:10:50	0.000	0.11
2003/03/13	01:10:55	0.000	0.08
2003/03/13	01:11:00	0.000	0.11
2003/03/13	01:11:05	0.000	0.11
2003/03/13	01:11:10	0.000	0.11
2003/03/13	01:11:15	0.000	0.10
2003/03/13	01:11:20	0.000	0.14
2003/03/13	01:11:25	0.000	0.13
2003/03/13	01:11:30	0.000	0.09
2003/03/13	01:11:35	0.000	0.14
2003/03/13	01:11:40	0.000	0.09
2003/03/13	01:11:45	0.000	0.11
2003/03/13	01:11:50	0.000	0.11
2003/03/13	01:11:55	0.000	0.10
2003/03/13	01:12:00	0.000	0.11
2003/03/13	01:12:05	0.000	0.09
2003/03/13	01:12:10	0.000	0.12
2003/03/13	01:12:15	0.000	0.12
2003/03/13	01:12:20	0.000	0.11
2003/03/13	01:12:25	0.000	0.12
2003/03/13	01:12:30	0.000	0.14
2003/03/13	01:12:35	0.000	0.12
2003/03/13	01:12:40	0.000	0.09
2003/03/13	01:12:45	0.000	0.14
2003/03/13	01:12:50	0.000	0.10
2003/03/13	01:12:55	0.000	0.11
2003/03/13	01:13:00	0.000	0.12
2003/03/13	01:13:05	0.000	0.10
2003/03/13	01:13:10	0.000	0.13
2003/03/13	01:13:15	0.000	0.09
2003/03/13	01:13:20	0.000	0.12
2003/03/13	01:13:25	0.000	0.12
2003/03/13	01:13:30	0.000	0.12
2003/03/13	01:13:35	0.000	0.13
2003/03/13	01:13:40	0.000	0.14
2003/03/13	01:13:45	0.000	0.12
2003/03/13	01:13:50	0.000	0.10
2003/03/13	01:13:55	0.000	0.15
2003/03/13	01:14:00	0.000	0.12
2003/03/13	01:14:05	0.000	0.12
2003/03/13	01:14:10	0.000	0.14
2003/03/13	01:14:15	0.000	0.12
2003/03/13	01:14:20	0.000	0.14
2003/03/13	01:14:25	0.000	0.12
2003/03/13	01:14:30	0.000	0.15
2003/03/13	01:14:35	0.000	0.15
2003/03/13	01:14:40	0.000	0.15
2003/03/13	01:14:45	0.000	0.18
2003/03/13	01:14:50	0.000	0.17
2003/03/13	01:14:55	0.000	0.18
2003/03/13	01:15:00	0.000	0.13
2003/03/13	01:15:05	0.000	0.18
2003/03/13	01:15:10	0.000	0.15
2003/03/13	01:15:15	0.000	0.14
2003/03/13	01:15:20	0.000	0.17
2003/03/13	01:15:25	0.000	0.14
2003/03/13	01:15:30	0.000	0.18
2003/03/13	01:15:35	0.000	0.14
2003/03/13	01:15:40	0.000	0.18
2003/03/13	01:15:45	0.000	0.17
2003/03/13	01:15:50	0.000	0.14
2003/03/13	01:15:55	0.000	0.18
2003/03/13	01:16:00	0.000	0.18
2003/03/13	01:16:05	0.000	0.17
2003/03/13	01:16:10	0.000	0.15
2003/03/13	01:16:15	0.000	0.20
2003/03/13	01:16:20	0.000	0.18
2003/03/13	01:16:25	0.000	0.18
2003/03/13	01:16:30	0.000	0.20
2003/03/13	01:16:35	0.000	0.18
2003/03/13	01:16:40	0.000	0.18
2003/03/13	01:16:45	0.000	0.18
2003/03/13	01:16:50	0.000	0.18
2003/03/13	01:16:55	0.000	0.20
2003/03/13	01:17:00	0.000	0.18
2003/03/13	01:17:05	0.000	0.21
2003/03/13	01:17:10	0.000	0.20
2003/03/13	01:17:15	0.000	0.20
2003/03/13	01:17:20	0.000	0.18
2003/03/13	01:17:25	0.000	0.22
2003/03/13	01:17:30	0.000	0.21
2003/03/13	01:17:35	0.000	0.17
2003/03/13	01:17:40	0.000	0.22
2003/03/13	01:17:45	0.000	0.17
2003/03/13	01:17:50	0.000	0.19

0.05

02031423 16010500

0.12

02031423 16010500

2003/03/13	01:17:55	0.000	0.19
2003/03/13	01:18:00	0.000	0.19
2003/03/13	01:18:05	0.000	0.19
2003/03/13	01:18:10	0.000	0.17
2003/03/13	01:18:15	0.000	0.20
2003/03/13	01:18:20	0.000	0.20
2003/03/13	01:18:25	0.000	0.20
2003/03/13	01:18:30	0.000	0.20
2003/03/13	01:18:35	0.000	0.22
2003/03/13	01:18:40	0.000	0.20
2003/03/13	01:18:45	0.000	0.17
2003/03/13	01:18:50	0.000	0.22
2003/03/13	01:18:55	0.000	0.18
2003/03/13	01:19:00	0.000	0.19
2003/03/13	01:19:05	0.000	0.20
2003/03/13	01:19:10	0.000	0.19
2003/03/13	01:19:15	0.000	0.21
2003/03/13	01:19:20	0.000	0.19
2003/03/13	01:19:25	0.000	0.21
2003/03/13	01:19:30	0.000	0.21
2003/03/13	01:19:35	0.000	0.20
2003/03/13	01:19:40	0.000	0.22
2003/03/13	01:19:45	0.000	0.23
2003/03/13	01:19:50	0.000	0.21
2003/03/13	01:19:55	0.000	0.19
2003/03/13	01:20:00	0.000	0.24
2003/03/13	01:20:05	0.000	0.20
2003/03/13	01:20:10	0.000	0.20
2003/03/13	01:20:15	0.000	0.23
2003/03/13	01:20:20	0.000	0.20
2003/03/13	01:20:25	0.000	0.22
2003/03/13	01:20:30	0.000	0.20
2003/03/13	01:20:35	0.000	0.23
2003/03/13	01:20:40	0.000	0.23
2003/03/13	01:20:45	0.000	0.22
2003/03/13	01:20:50	0.000	0.26
2003/03/13	01:20:55	0.000	0.28
2003/03/13	01:21:00	0.000	0.26
2003/03/13	01:21:05	0.000	0.23
2003/03/13	01:21:10	0.000	0.28
2003/03/13	01:21:15	0.000	0.26
2003/03/13	01:21:20	0.000	0.24
2003/03/13	01:21:25	0.000	0.28
2003/03/13	01:21:30	0.000	0.24
2003/03/13	01:21:35	0.000	0.28
2003/03/13	01:21:40	0.000	0.24
2003/03/13	01:21:45	0.000	0.28
2003/03/13	01:21:50	0.000	0.27
2003/03/13	01:21:55	0.000	0.24
2003/03/13	01:22:00	0.000	0.27
2003/03/13	01:22:05	0.000	0.28
2003/03/13	01:22:10	0.000	0.24
2003/03/13	01:22:15	0.000	0.18
2003/03/13	01:22:20	0.000	0.18
2003/03/13	01:22:25	0.000	0.12
2003/03/13	01:22:30	0.000	0.06
2003/03/13	01:22:35	0.000	0.07
2003/03/13	01:22:40	0.000	0.00
2003/03/13	01:22:45	0.000	0.01
2003/03/13	01:22:50	0.000	0.00
2003/03/13	01:22:55	0.000	0.00
2003/03/13	01:23:00	0.000	0.05
2003/03/13	01:23:05	0.000	0.07
2003/03/13	01:23:10	0.000	0.12
2003/03/13	01:23:15	0.000	0.12
2003/03/13	01:23:20	0.000	0.10
2003/03/13	01:23:25	0.000	0.09
2003/03/13	01:23:30	0.000	0.11
2003/03/13	01:23:35	0.000	0.08
2003/03/13	01:23:40	0.000	0.03
2003/03/13	01:23:45	0.000	0.08
2003/03/13	01:23:50	0.000	0.03
2003/03/13	01:23:55	0.000	0.06
2003/03/13	01:24:00	0.000	0.04
2003/03/13	01:24:05	0.000	0.02
2003/03/13	01:24:10	0.000	0.01
2003/03/13	01:24:15	0.000	-0.02
2003/03/13	01:24:20	0.000	0.01
2003/03/13	01:24:25	0.000	0.00
2003/03/13	01:24:30	0.000	0.00
2003/03/13	01:24:35	0.000	0.01
2003/03/13	01:24:40	0.000	0.03
2003/03/13	01:24:45	0.000	0.01
2003/03/13	01:24:50	0.000	-0.02
2003/03/13	01:24:55	0.000	0.03
2003/03/13	01:25:00	0.000	-0.01
2003/03/13	01:25:05	0.000	0.00
2003/03/13	01:25:10	0.000	0.02
2003/03/13	01:25:15	0.000	0.00
2003/03/13	01:25:20	0.000	0.04
2003/03/13	01:25:25	0.000	0.02
2003/03/13	01:25:30	0.000	0.05
2003/03/13	01:25:35	0.000	0.08
2003/03/13	01:25:40	0.000	0.06
2003/03/13	01:25:45	0.000	0.08
2003/03/13	01:25:50	0.000	0.09
2003/03/13	01:25:55	0.000	0.08
2003/03/13	01:26:00	0.000	0.08
2003/03/13	01:26:05	0.000	0.11
2003/03/13	01:26:10	0.000	0.08
2003/03/13	01:26:15	0.000	0.07
2003/03/13	01:26:20	0.000	0.11
2003/03/13	01:26:25	0.000	0.07
2003/03/13	01:26:30	0.000	0.09
2003/03/13	01:26:35	0.000	0.07
2003/03/13	01:26:40	0.000	0.10
2003/03/13	01:26:45	0.000	0.11
2003/03/13	01:26:50	0.000	0.06
2003/03/13	01:26:55	0.000	0.11
2003/03/13	01:27:00	0.000	0.13
2003/03/13	01:27:05	0.000	0.12
2003/03/13	01:27:10	0.000	0.09
2003/03/13	01:27:15	0.000	0.14
2003/03/13	01:27:20	0.000	0.12
2003/03/13	01:27:25	0.000	0.10
2003/03/13	01:27:30	0.000	0.15
2003/03/13	01:27:35	0.000	0.10
2003/03/13	01:27:40	0.000	0.12
2003/03/13	01:27:45	0.000	0.10
2003/03/13	01:27:50	0.000	0.12
2003/03/13	01:27:55	0.000	0.13
2003/03/13	01:28:00	0.000	0.10
2003/03/13	01:28:05	0.000	0.13
2003/03/13	01:28:10	0.000	0.14
2003/03/13	01:28:15	0.000	0.13
2003/03/13	01:28:20	0.000	0.12
2003/03/13	01:28:25	0.000	0.16
2003/03/13	01:28:30	0.000	0.16
2003/03/13	01:28:35	0.000	0.11
2003/03/13	01:28:40	0.000	0.16
2003/03/13	01:28:45	0.000	0.12
2003/03/13	01:28:50	0.000	0.14
2003/03/13	01:28:55	0.000	0.14
2003/03/13	01:29:00	0.000	0.14

0.19

0.19

0.14

0.14

2003/03/13	01:28:05	0.000	0.18
2003/03/13	01:28:10	0.000	0.14
2003/03/13	01:28:15	0.000	0.17
2003/03/13	01:28:20	0.000	0.18
2003/03/13	01:28:25	0.000	0.18
2003/03/13	01:28:30	0.000	0.18
2003/03/13	01:28:35	0.000	0.19
2003/03/13	01:28:40	0.000	0.18
2003/03/13	01:28:45	0.000	0.18
2003/03/13	01:28:50	0.000	0.21
2003/03/13	01:28:55	0.000	0.17
2003/03/13	01:30:00	0.000	0.19
2003/03/13	01:30:05	0.000	0.19
2003/03/13	01:30:10	0.000	0.18
2003/03/13	01:30:15	0.000	0.20
2003/03/13	01:30:20	0.000	0.18
2003/03/13	01:30:25	0.000	0.22
2003/03/13	01:30:30	0.000	0.21
2003/03/13	01:30:35	0.000	0.21
2003/03/13	01:30:40	0.000	0.24
2003/03/13	01:30:45	0.000	0.25
2003/03/13	01:30:50	0.000	0.24
2003/03/13	01:30:55	0.000	0.21
2003/03/13	01:31:00	0.000	0.27
2003/03/13	01:31:05	0.000	0.23
2003/03/13	01:31:10	0.000	0.23
2003/03/13	01:31:15	0.000	0.25
2003/03/13	01:31:20	0.000	0.23
2003/03/13	01:31:25	0.000	0.25
2003/03/13	01:31:30	0.000	0.22
2003/03/13	01:31:35	0.000	0.25
2003/03/13	01:31:40	0.000	0.25
2003/03/13	01:31:45	0.000	0.25
2003/03/13	01:31:50	0.000	0.27
2003/03/13	01:31:55	0.000	0.28
2003/03/13	01:32:00	0.000	0.27
2003/03/13	01:32:05	0.000	0.25
2003/03/13	01:32:10	0.000	0.30
2003/03/13	01:32:15	0.000	0.27
2003/03/13	01:32:20	0.000	0.26
2003/03/13	01:32:25	0.000	0.29
2003/03/13	01:32:30	0.000	0.28
2003/03/13	01:32:35	0.000	0.28
2003/03/13	01:32:40	0.000	0.28
2003/03/13	01:32:45	0.000	0.29
2003/03/13	01:32:50	0.000	0.29
2003/03/13	01:32:55	0.000	0.28
2003/03/13	01:33:00	0.000	0.30
2003/03/13	01:33:05	0.000	0.32
2003/03/13	01:33:10	0.000	0.31
2003/03/13	01:33:15	0.000	0.28
2003/03/13	01:33:20	0.000	0.34
2003/03/13	01:33:25	0.000	0.31
2003/03/13	01:33:30	0.000	0.30
2003/03/13	01:33:35	0.000	0.34
2003/03/13	01:33:40	0.000	0.30
2003/03/13	01:33:45	0.000	0.32
2003/03/13	01:33:50	0.000	0.31
2003/03/13	01:33:55	0.000	0.33
2003/03/13	01:34:00	0.000	0.34
2003/03/13	01:34:05	0.000	0.31
2003/03/13	01:34:10	0.000	0.33
2003/03/13	01:34:15	0.000	0.35
2003/03/13	01:34:20	0.000	0.33
2003/03/13	01:34:25	0.000	0.32
2003/03/13	01:34:30	0.000	0.37
2003/03/13	01:34:35	0.000	0.35
2003/03/13	01:34:40	0.000	0.32
2003/03/13	01:34:45	0.000	0.38
2003/03/13	01:34:50	0.000	0.32
2003/03/13	01:34:55	0.000	0.34
2003/03/13	01:35:00	0.000	0.34
2003/03/13	01:35:05	0.000	0.34
2003/03/13	01:35:10	0.000	0.38
2003/03/13	01:35:15	0.000	0.33
2003/03/13	01:35:20	0.000	0.38
2003/03/13	01:35:25	0.000	0.38
2003/03/13	01:35:30	0.000	0.36
2003/03/13	01:35:35	0.000	0.35
2003/03/13	01:35:40	0.000	0.38
2003/03/13	01:35:45	0.000	0.38
2003/03/13	01:35:50	0.000	0.34
2003/03/13	01:35:55	0.000	0.39
2003/03/13	01:36:00	0.000	0.35
2003/03/13	01:36:05	0.000	0.38
2003/03/13	01:36:10	0.000	0.37
2003/03/13	01:36:15	0.000	0.38
2003/03/13	01:36:20	0.000	0.37
2003/03/13	01:36:25	0.000	0.38
2003/03/13	01:36:30	0.000	0.38
2003/03/13	01:36:35	0.000	0.88
2003/03/13	01:36:40	0.000	0.37
2003/03/13	01:36:45	0.000	0.39
2003/03/13	01:36:50	0.000	0.40
2003/03/13	01:36:55	0.000	0.38
2003/03/13	01:37:00	0.000	0.35
2003/03/13	01:37:05	0.000	0.41
2003/03/13	01:37:10	0.000	0.37
2003/03/13	01:37:15	0.000	0.37
2003/03/13	01:37:20	0.000	0.38
2003/03/13	01:37:25	0.000	0.38
2003/03/13	01:37:30	0.000	0.39
2003/03/13	01:37:35	0.000	0.38
2003/03/13	01:37:40	0.000	0.39
2003/03/13	01:37:45	0.000	0.39
2003/03/13	01:37:50	0.000	0.39
2003/03/13	01:37:55	0.000	0.41
2003/03/13	01:38:00	0.000	0.42
2003/03/13	01:38:05	0.000	0.40
2003/03/13	01:38:10	0.000	0.38
2003/03/13	01:38:15	0.000	0.43
2003/03/13	01:38:20	0.000	0.40
2003/03/13	01:38:25	0.000	0.39
2003/03/13	01:38:30	0.000	0.43
2003/03/13	01:38:35	0.000	0.40
2003/03/13	01:38:40	0.000	0.43
2003/03/13	01:38:45	0.000	0.41
2003/03/13	01:38:50	0.000	0.43
2003/03/13	01:38:55	0.000	0.44
2003/03/13	01:39:00	0.000	0.42
2003/03/13	01:39:05	0.000	0.44
2003/03/13	01:39:10	0.000	0.45
2003/03/13	01:39:15	0.000	0.43
2003/03/13	01:39:20	0.000	0.41
2003/03/13	01:39:25	0.000	0.48
2003/03/13	01:39:30	0.000	0.42
2003/03/13	01:39:35	0.000	0.35
2003/03/13	01:39:40	0.000	0.32
2003/03/13	01:39:45	0.000	0.20
2003/03/13	01:39:50	0.000	0.17
2003/03/13	01:39:55	0.000	0.11
2003/03/13	01:40:00	0.000	0.08
2003/03/13	01:40:05	0.000	0.07
2003/03/13	01:40:10	0.000	0.02

0.11

0.11

0.28

0.28

0.37

0.37

2003/03/13	01:40:18	0.000	0.03
2003/03/13	01:40:20	0.000	0.02
2003/03/13	01:40:25	0.000	0.01
2003/03/13	01:40:30	0.000	0.01
2003/03/13	01:40:35	0.000	0.10
2003/03/13	01:40:40	0.000	0.17
2003/03/13	01:40:45	0.000	0.21
2003/03/13	01:40:50	0.000	0.31
2003/03/13	01:40:55	0.000	0.31
2003/03/13	01:41:00	0.000	0.38
2003/03/13	01:41:05	0.000	0.37
2003/03/13	01:41:10	0.000	0.38
2003/03/13	01:41:15	0.000	0.39
2003/03/13	01:41:20	0.000	0.32
2003/03/13	01:41:25	0.000	0.28
2003/03/13	01:41:30	0.000	0.20
2003/03/13	01:41:35	0.000	0.15
2003/03/13	01:41:40	0.000	0.10
2003/03/13	01:41:45	0.000	0.09
2003/03/13	01:41:50	0.000	0.07
2003/03/13	01:41:55	0.000	0.01
2003/03/13	01:42:00	0.000	0.04
2003/03/13	01:42:05	0.000	-0.01
2003/03/13	01:42:10	0.000	0.00
2003/03/13	01:42:15	0.000	0.01
2003/03/13	01:42:20	0.000	-0.01
2003/03/13	01:42:25	0.000	0.00
2003/03/13	01:42:30	0.000	-0.02
2003/03/13	01:42:35	0.000	0.01
2003/03/13	01:42:40	0.000	0.00
2003/03/13	01:42:45	0.000	0.00
2003/03/13	01:42:50	0.000	0.02
2003/03/13	01:42:55	0.000	0.03
2003/03/13	01:43:00	0.000	0.01
2003/03/13	01:43:05	0.000	-0.02
2003/03/13	01:43:10	0.000	0.03
2003/03/13	01:43:15	0.000	-0.01
2003/03/13	01:43:20	0.000	-0.01
2003/03/13	01:43:25	0.000	0.02
2003/03/13	01:43:30	0.000	-0.01
2003/03/13	01:43:35	0.000	0.01
2003/03/13	01:43:40	0.000	-0.02
2003/03/13	01:43:45	0.000	0.01
2003/03/13	01:43:50	0.000	0.01
2003/03/13	01:43:55	0.000	0.00
2003/03/13	01:44:00	0.000	0.03
2003/03/13	01:44:05	0.000	0.04
2003/03/13	01:44:10	0.000	0.03
2003/03/13	01:44:15	0.000	0.02
2003/03/13	01:44:20	0.000	0.08
2003/03/13	01:44:25	0.000	0.05
2003/03/13	01:44:30	0.000	0.04
2003/03/13	01:44:35	0.000	0.08
2003/03/13	01:44:40	0.000	0.05
2003/03/13	01:44:45	0.000	0.07
2003/03/13	01:44:50	0.000	0.06
2003/03/13	01:44:55	0.000	0.08
2003/03/13	01:45:00	0.000	0.09
2003/03/13	01:45:05	0.000	0.07
2003/03/13	01:45:10	0.000	0.10
2003/03/13	01:45:15	0.000	0.11
2003/03/13	01:45:20	0.000	0.10
2003/03/13	01:45:25	0.000	0.07
2003/03/13	01:45:30	0.000	0.12
2003/03/13	01:45:35	0.000	0.09
2003/03/13	01:45:40	0.000	0.07
2003/03/13	01:45:45	0.000	0.11
2003/03/13	01:45:50	0.000	0.07
2003/03/13	01:45:55	0.000	0.09
2003/03/13	01:46:00	0.000	0.08
2003/03/13	01:46:05	0.000	0.09
2003/03/13	01:46:10	0.000	0.10
2003/03/13	01:46:15	0.000	0.08
2003/03/13	01:46:20	0.000	0.10
2003/03/13	01:46:25	0.000	0.11
2003/03/13	01:46:30	0.000	0.10
2003/03/13	01:46:35	0.000	0.09
2003/03/13	01:46:40	0.000	0.13
2003/03/13	01:46:45	0.000	0.12
2003/03/13	01:46:50	0.000	0.08
2003/03/13	01:46:55	0.000	0.13
2003/03/13	01:47:00	0.000	0.08
2003/03/13	01:47:05	0.000	0.10
2003/03/13	01:47:10	0.000	0.10
2003/03/13	01:47:15	0.000	0.10
2003/03/13	01:47:20	0.000	0.12
2003/03/13	01:47:25	0.000	0.09
2003/03/13	01:47:30	0.000	0.13
2003/03/13	01:47:35	0.000	0.12
2003/03/13	01:47:40	0.000	0.11
2003/03/13	01:47:45	0.000	0.12
2003/03/13	01:47:50	0.000	0.14
2003/03/13	01:47:55	0.000	0.13
2003/03/13	01:48:00	0.000	0.10
2003/03/13	01:48:05	0.000	0.15
2003/03/13	01:48:10	0.000	0.10
2003/03/13	01:48:15	0.000	0.12
2003/03/13	01:48:20	0.000	0.13
2003/03/13	01:48:25	0.000	0.11
2003/03/13	01:48:30	0.000	0.12
2003/03/13	01:48:35	0.000	0.11
2003/03/13	01:48:40	0.000	0.14
2003/03/13	01:48:45	0.000	0.18
2003/03/13	01:48:50	0.000	0.13
2003/03/13	01:48:55	0.000	0.15
2003/03/13	01:49:00	0.000	0.18
2003/03/13	01:49:05	0.000	0.14
2003/03/13	01:49:10	0.000	0.12
2003/03/13	01:49:15	0.000	0.17
2003/03/13	01:49:20	0.000	0.13
2003/03/13	01:49:25	0.000	0.13
2003/03/13	01:49:30	0.000	0.18
2003/03/13	01:49:35	0.000	0.13
2003/03/13	01:49:40	0.000	0.15
2003/03/13	01:49:45	0.000	0.13
2003/03/13	01:49:50	0.000	0.18
2003/03/13	01:49:55	0.000	0.18
2003/03/13	01:50:00	0.000	0.15
2003/03/13	01:50:05	0.000	0.18
2003/03/13	01:50:10	0.000	0.18
2003/03/13	01:50:15	0.000	0.17
2003/03/13	01:50:20	0.000	0.14
2003/03/13	01:50:25	0.000	0.19
2003/03/13	01:50:30	0.000	0.18
2003/03/13	01:50:35	0.000	0.15
2003/03/13	01:50:40	0.000	0.19
2003/03/13	01:50:45	0.000	0.18
2003/03/13	01:50:50	0.000	0.18
2003/03/13	01:50:55	0.000	0.17
2003/03/13	01:51:00	0.000	0.19
2003/03/13	01:51:05	0.000	0.20
2003/03/13	01:51:10	0.000	0.18
2003/03/13	01:51:15	0.000	0.20
2003/03/13	01:51:20	0.000	0.22

0.08

20030724 10:00:00

0.11

20030724 10:00:00

2003/03/13	01:51:25	0.000	0.21
2003/03/13	01:51:30	0.000	0.19
2003/03/13	01:51:35	0.000	0.24
2003/03/13	01:51:40	0.000	0.21
2003/03/13	01:51:45	0.000	0.19
2003/03/13	01:51:50	0.000	0.24
2003/03/13	01:51:55	0.000	0.20
2003/03/13	01:52:00	0.000	0.22
2003/03/13	01:52:05	0.000	0.22
2003/03/13	01:52:10	0.000	0.22
2003/03/13	01:52:15	0.000	0.24
2003/03/13	01:52:20	0.000	0.21
2003/03/13	01:52:25	0.000	0.24
2003/03/13	01:52:30	0.000	0.25
2003/03/13	01:52:35	0.000	0.24
2003/03/13	01:52:40	0.000	0.23
2003/03/13	01:52:45	0.000	0.27
2003/03/13	01:52:50	0.000	0.26
2003/03/13	01:52:55	0.000	0.22
2003/03/13	01:53:00	0.000	0.27
2003/03/13	01:53:05	0.000	0.22
2003/03/13	01:53:10	0.000	0.24
2003/03/13	01:53:15	0.000	0.24
2003/03/13	01:53:20	0.000	0.23
2003/03/13	01:53:25	0.000	0.25
2003/03/13	01:53:30	0.000	0.23
2003/03/13	01:53:35	0.000	0.26
2003/03/13	01:53:40	0.000	0.25
2003/03/13	01:53:45	0.000	0.25
2003/03/13	01:53:50	0.000	0.25
2003/03/13	01:53:55	0.000	0.27
2003/03/13	01:54:00	0.000	0.26
2003/03/13	01:54:05	0.000	0.22
2003/03/13	01:54:10	0.000	0.27
2003/03/13	01:54:15	0.000	0.23
2003/03/13	01:54:20	0.000	0.24
2003/03/13	01:54:25	0.000	0.24
2003/03/13	01:54:30	0.000	0.22
2003/03/13	01:54:35	0.000	0.23
2003/03/13	01:54:40	0.000	0.22
2003/03/13	01:54:45	0.000	0.24
2003/03/13	01:54:50	0.000	0.24
2003/03/13	01:54:55	0.000	0.23
2003/03/13	01:55:00	0.000	0.25
2003/03/13	01:55:05	0.000	0.26
2003/03/13	01:55:10	0.000	0.24
2003/03/13	01:55:15	0.000	0.21
2003/03/13	01:55:20	0.000	0.27
2003/03/13	01:55:25	0.000	0.23
2003/03/13	01:55:30	0.000	0.23
2003/03/13	01:55:35	0.000	0.25
2003/03/13	01:55:40	0.000	0.22
2003/03/13	01:55:45	0.000	0.24
2003/03/13	01:55:50	0.000	0.21
2003/03/13	01:55:55	0.000	0.24
2003/03/13	01:56:00	0.000	0.25
2003/03/13	01:56:05	0.000	0.23
2003/03/13	01:56:10	0.000	0.26
2003/03/13	01:56:15	0.000	0.27
2003/03/13	01:56:20	0.000	0.24
2003/03/13	01:56:25	0.000	0.22
2003/03/13	01:56:30	0.000	0.27
2003/03/13	01:56:35	0.000	0.24
2003/03/13	01:56:40	0.000	0.22
2003/03/13	01:56:45	0.000	0.26
2003/03/13	01:56:50	0.000	0.22
2003/03/13	01:56:55	0.000	0.24
2003/03/13	01:57:00	0.000	0.23
2003/03/13	01:57:05	0.000	0.24
2003/03/13	01:57:10	0.000	0.25
2003/03/13	01:57:15	0.000	0.23
2003/03/13	01:57:20	0.000	0.26
2003/03/13	01:57:25	0.000	0.26
2003/03/13	01:57:30	0.000	0.25
2003/03/13	01:57:35	0.000	0.24
2003/03/13	01:57:40	0.000	0.26
2003/03/13	01:57:45	0.000	0.23
2003/03/13	01:57:50	0.000	0.18
2003/03/13	01:57:55	0.000	0.15
2003/03/13	01:58:00	0.000	0.08
2003/03/13	01:58:05	0.000	0.08
2003/03/13	01:58:10	0.000	0.03
2003/03/13	01:58:15	0.000	0.01
2003/03/13	01:58:20	0.000	0.02
2003/03/13	01:58:25	0.000	-0.01
2003/03/13	01:58:30	0.000	0.01
2003/03/13	01:58:35	0.000	0.06
2003/03/13	01:58:40	0.000	0.09
2003/03/13	01:58:45	0.000	0.09
2003/03/13	01:58:50	0.000	0.11
2003/03/13	01:58:55	0.000	0.07
2003/03/13	01:59:00	0.000	0.02
2003/03/13	01:59:05	0.000	0.05
2003/03/13	01:59:10	0.000	-0.01
2003/03/13	01:59:15	0.000	0.00
2003/03/13	01:59:20	0.000	0.00
2003/03/13	01:59:25	0.000	-0.01
2003/03/13	01:59:30	0.000	0.01
2003/03/13	01:59:35	0.000	-0.01
2003/03/13	01:59:40	0.000	0.03
2003/03/13	01:59:45	0.000	0.03
2003/03/13	01:59:50	0.000	0.04
2003/03/13	01:59:55	0.000	0.06
2003/03/13	02:00:00	0.000	0.08
2003/03/13	02:00:05	0.000	0.06
2003/03/13	02:00:10	0.000	0.02
2003/03/13	02:00:15	0.000	0.07
2003/03/13	02:00:20	0.000	0.03
2003/03/13	02:00:25	0.000	0.03
2003/03/13	02:00:30	0.000	0.03
2003/03/13	02:00:35	0.000	0.00
2003/03/13	02:00:40	0.000	0.01
2003/03/13	02:00:45	0.000	-0.02
2003/03/13	02:00:50	0.000	0.01
2003/03/13	02:00:55	0.000	0.01
2003/03/13	02:01:00	0.000	0.00
2003/03/13	02:01:05	0.000	0.02
2003/03/13	02:01:10	0.000	0.03
2003/03/13	02:01:15	0.000	0.01
2003/03/13	02:01:20	0.000	-0.02
2003/03/13	02:01:25	0.000	0.03
2003/03/13	02:01:30	0.000	0.00
2003/03/13	02:01:35	0.000	-0.01
2003/03/13	02:01:40	0.000	0.02
2003/03/13	02:01:45	0.000	-0.01
2003/03/13	02:01:50	0.000	0.01
2003/03/13	02:01:55	0.000	-0.02
2003/03/13	02:02:00	0.000	0.01
2003/03/13	02:02:05	0.000	0.01
2003/03/13	02:02:10	0.000	-0.01
2003/03/13	02:02:15	0.000	0.02
2003/03/13	02:02:20	0.000	0.02
2003/03/13	02:02:25	0.000	0.01
2003/03/13	02:02:30	0.000	-0.01

0.22

2003/03/13 11:05:00

0.16

2003/03/13 11:05:00

2003/03/13	02:02:36	0.000	0.04
2003/03/13	02:02:40	0.000	0.01
2003/03/13	02:02:44	0.000	-0.01
2003/03/13	02:02:50	0.000	0.03
2003/03/13	02:02:54	0.000	-0.02
2003/03/13	02:03:00	0.000	0.01
2003/03/13	02:03:06	0.000	-0.01
2003/03/13	02:03:10	0.000	0.01
2003/03/13	02:03:16	0.000	0.02
2003/03/13	02:03:20	0.000	-0.01
2003/03/13	02:03:26	0.000	0.01
2003/03/13	02:03:30	0.000	0.01
2003/03/13	02:03:36	0.000	0.01
2003/03/13	02:03:40	0.000	-0.01
2003/03/13	02:03:46	0.000	0.03
2003/03/13	02:03:50	0.000	0.01
2003/03/13	02:03:56	0.000	-0.02
2003/03/13	02:04:00	0.000	0.03
2003/03/13	02:04:06	0.000	-0.02
2003/03/13	02:04:10	0.000	0.00
2003/03/13	02:04:15	0.000	0.00
2003/03/13	02:04:20	0.000	0.00
2003/03/13	02:04:25	0.000	0.02
2003/03/13	02:04:30	0.000	-0.01
2003/03/13	02:04:35	0.000	0.01
2003/03/13	02:04:40	0.000	0.01
2003/03/13	02:04:45	0.000	0.01
2003/03/13	02:04:50	0.000	0.03
2003/03/13	02:04:55	0.000	0.02
2003/03/13	02:05:00	0.000	-0.02
2003/03/13	02:05:05	0.000	0.03
2003/03/13	02:05:10	0.000	0.03
2003/03/13	02:05:15	0.000	-0.02
2003/03/13	02:05:20	0.000	0.00
2003/03/13	02:05:25	0.000	0.00
2003/03/13	02:05:30	0.000	-0.01
2003/03/13	02:05:35	0.000	0.01
2003/03/13	02:05:40	0.000	-0.01
2003/03/13	02:05:45	0.000	0.01
2003/03/13	02:05:50	0.000	0.00
2003/03/13	02:05:55	0.000	0.00
2003/03/13	02:06:00	0.000	0.01
2003/03/13	02:06:05	0.000	0.03
2003/03/13	02:06:10	0.000	0.02
2003/03/13	02:06:15	0.000	-0.02
2003/03/13	02:06:20	0.000	0.03
2003/03/13	02:06:25	0.000	-0.01
2003/03/13	02:06:30	0.000	0.00
2003/03/13	02:06:35	0.000	0.01
2003/03/13	02:06:40	0.000	-0.01
2003/03/13	02:06:45	0.000	0.00
2003/03/13	02:06:50	0.000	-0.02
2003/03/13	02:06:55	0.000	0.01
2003/03/13	02:07:00	0.000	0.01
2003/03/13	02:07:05	0.000	0.00
2003/03/13	02:07:10	0.000	0.02
2003/03/13	02:07:15	0.000	0.03
2003/03/13	02:07:20	0.000	0.01
2003/03/13	02:07:25	0.000	-0.02
2003/03/13	02:07:30	0.000	0.04
2003/03/13	02:07:35	0.000	0.00
2003/03/13	02:07:40	0.000	-0.01
2003/03/13	02:07:45	0.000	0.02
2003/03/13	02:07:50	0.000	-0.01
2003/03/13	02:07:55	0.000	0.01
2003/03/13	02:08:00	0.000	-0.01
2003/03/13	02:08:05	0.000	0.01
2003/03/13	02:08:10	0.000	0.01
2003/03/13	02:08:15	0.000	-0.01
2003/03/13	02:08:20	0.000	0.02
2003/03/13	02:08:25	0.000	0.02
2003/03/13	02:08:30	0.000	0.01
2003/03/13	02:08:35	0.000	-0.01
2003/03/13	02:08:40	0.000	0.03
2003/03/13	02:08:45	0.000	0.01
2003/03/13	02:08:50	0.000	-0.01
2003/03/13	02:08:55	0.000	0.03
2003/03/13	02:09:00	0.000	-0.02
2003/03/13	02:09:05	0.000	0.01
2003/03/13	02:09:10	0.000	-0.01
2003/03/13	02:09:15	0.000	0.00
2003/03/13	02:09:20	0.000	0.02
2003/03/13	02:09:25	0.000	-0.01
2003/03/13	02:09:30	0.000	0.01
2003/03/13	02:09:35	0.000	0.01
2003/03/13	02:09:40	0.000	0.01
2003/03/13	02:09:45	0.000	-0.01
2003/03/13	02:09:50	0.000	0.03
2003/03/13	02:09:55	0.000	0.01
2003/03/13	02:10:00	0.000	-0.01
2003/03/13	02:10:05	0.000	0.03
2003/03/13	02:10:10	0.000	-0.02
2003/03/13	02:10:15	0.000	0.00
2003/03/13	02:10:20	0.000	0.00
2003/03/13	02:10:25	0.000	0.00
2003/03/13	02:10:30	0.000	0.02
2003/03/13	02:10:35	0.000	-0.02
2003/03/13	02:10:40	0.000	0.01
2003/03/13	02:10:45	0.000	0.01
2003/03/13	02:10:50	0.000	0.01
2003/03/13	02:10:55	0.000	0.02
2003/03/13	02:11:00	0.000	0.03
2003/03/13	02:11:05	0.000	0.02
2003/03/13	02:11:10	0.000	-0.02
2003/03/13	02:11:15	0.000	0.03
2003/03/13	02:11:20	0.000	-0.01
2003/03/13	02:11:25	0.000	0.00
2003/03/13	02:11:30	0.000	0.01
2003/03/13	02:11:35	0.000	-0.01
2003/03/13	02:11:40	0.000	0.01
2003/03/13	02:11:45	0.000	-0.01
2003/03/13	02:11:50	0.000	0.01
2003/03/13	02:11:55	0.000	0.00
2003/03/13	02:12:00	0.000	0.00
2003/03/13	02:12:05	0.000	0.01
2003/03/13	02:12:10	0.000	0.03
2003/03/13	02:12:15	0.000	0.02
2003/03/13	02:12:20	0.000	-0.02
2003/03/13	02:12:25	0.000	0.03
2003/03/13	02:12:30	0.000	-0.01
2003/03/13	02:12:35	0.000	0.00
2003/03/13	02:12:40	0.000	0.01
2003/03/13	02:12:45	0.000	-0.01
2003/03/13	02:12:50	0.000	0.00
2003/03/13	02:12:55	0.000	-0.02
2003/03/13	02:13:00	0.000	0.01
2003/03/13	02:13:05	0.000	0.01
2003/03/13	02:13:10	0.000	0.00
2003/03/13	02:13:15	0.000	0.02
2003/03/13	02:13:20	0.000	0.03
2003/03/13	02:13:25	0.000	0.01
2003/03/13	02:13:30	0.000	-0.02
2003/03/13	02:13:35	0.000	0.04
2003/03/13	02:13:40	0.000	0.00

0.01

██████████

0.01

██████████

2003/03/13	02:13:45	0.000	-0.01
2003/03/13	02:13:50	0.000	0.02
2003/03/13	02:13:55	0.000	-0.01
2003/03/13	02:14:00	0.000	0.01
2003/03/13	02:14:05	0.000	-0.01
2003/03/13	02:14:10	0.000	0.01
2003/03/13	02:14:15	0.000	0.01
2003/03/13	02:14:20	0.000	-0.01
2003/03/13	02:14:25	0.000	0.02
2003/03/13	02:14:30	0.000	0.02
2003/03/13	02:14:35	0.000	0.01
2003/03/13	02:14:40	0.000	0.00
2003/03/13	02:14:45	0.000	0.04
2003/03/13	02:14:50	0.000	0.02
2003/03/13	02:14:55	0.000	0.00
2003/03/13	02:15:00	0.000	0.03
2003/03/13	02:15:05	0.000	-0.01
2003/03/13	02:15:10	0.000	0.01
2003/03/13	02:15:15	0.000	0.00
2003/03/13	02:15:20	0.000	0.02
2003/03/13	02:15:25	0.000	0.03
2003/03/13	02:15:30	0.000	0.00
2003/03/13	02:15:35	0.000	0.02
2003/03/13	02:15:40	0.000	0.03
2003/03/13	02:15:45	0.000	0.02
2003/03/13	02:15:50	0.000	0.01
2003/03/13	02:15:55	0.000	0.04
2003/03/13	02:16:00	0.000	0.02
2003/03/13	02:16:05	0.000	0.00
2003/03/13	02:16:10	0.000	0.04
2003/03/13	02:16:15	0.000	-0.02
2003/03/13	02:16:20	0.000	0.00
2003/03/13	02:16:25	0.000	0.00
2003/03/13	02:16:30	0.000	0.00
2003/03/13	02:16:35	0.000	0.02
2003/03/13	02:16:40	0.000	-0.02
2003/03/13	02:16:45	0.000	0.01
2003/03/13	02:16:50	0.000	0.01
2003/03/13	02:16:55	0.000	0.01
2003/03/13	02:17:00	0.000	0.00
2003/03/13	02:17:05	0.000	0.03
2003/03/13	02:17:10	0.000	0.02
2003/03/13	02:17:15	0.000	-0.01
2003/03/13	02:17:20	0.000	0.04
2003/03/13	02:17:25	0.000	-0.01
2003/03/13	02:17:30	0.000	0.01
2003/03/13	02:17:35	0.000	0.02
2003/03/13	02:17:40	0.000	0.00
2003/03/13	02:17:45	0.000	0.02
2003/03/13	02:17:50	0.000	-0.01
2003/03/13	02:17:55	0.000	0.02
2003/03/13	02:18:00	0.000	0.00
2003/03/13	02:18:05	0.000	0.00
2003/03/13	02:18:10	0.000	0.01
2003/03/13	02:18:15	0.000	0.03
2003/03/13	02:18:20	0.000	0.02
2003/03/13	02:18:25	0.000	-0.02
2003/03/13	02:18:30	0.000	0.03
2003/03/13	02:18:35	0.000	-0.01
2003/03/13	02:18:40	0.000	0.00
2003/03/13	02:18:45	0.000	0.01
2003/03/13	02:18:50	0.000	-0.01
2003/03/13	02:18:55	0.000	0.00
2003/03/13	02:19:00	0.000	-0.02
2003/03/13	02:19:05	0.000	0.01
2003/03/13	02:19:10	0.000	0.01
2003/03/13	02:19:15	0.000	0.00
2003/03/13	02:19:20	0.000	0.02
2003/03/13	02:19:25	0.000	0.03
2003/03/13	02:19:30	0.000	0.01
2003/03/13	02:19:35	0.000	-0.02
2003/03/13	02:19:40	0.000	0.03
2003/03/13	02:19:45	0.000	0.00
2003/03/13	02:19:50	0.000	-0.01
2003/03/13	02:19:55	0.000	0.02
2003/03/13	02:20:00	0.000	-0.01
2003/03/13	02:20:05	0.000	0.01
2003/03/13	02:20:10	0.000	-0.01
2003/03/13	02:20:15	0.000	0.01
2003/03/13	02:20:20	0.000	0.01
2003/03/13	02:20:25	0.000	-0.01
2003/03/13	02:20:30	0.000	0.02
2003/03/13	02:20:35	0.000	0.02
2003/03/13	02:20:40	0.000	0.01
2003/03/13	02:20:45	0.000	-0.01
2003/03/13	02:20:50	0.000	0.03
2003/03/13	02:20:55	0.000	0.01
2003/03/13	02:21:00	0.000	-0.01
2003/03/13	02:21:05	0.000	0.03
2003/03/13	02:21:10	0.000	-0.02
2003/03/13	02:21:15	0.000	0.01
2003/03/13	02:21:20	0.000	-0.01
2003/03/13	02:21:25	0.000	0.00
2003/03/13	02:21:30	0.000	0.02
2003/03/13	02:21:35	0.000	-0.01
2003/03/13	02:21:40	0.000	0.01
2003/03/13	02:21:45	0.000	0.01
2003/03/13	02:21:50	0.000	0.01
2003/03/13	02:21:55	0.000	0.00
2003/03/13	02:22:00	0.000	0.03
2003/03/13	02:22:05	0.000	0.01
2003/03/13	02:22:10	0.000	-0.01
2003/03/13	02:22:15	0.000	0.03
2003/03/13	02:22:20	0.000	-0.02
2003/03/13	02:22:25	0.000	0.00
2003/03/13	02:22:30	0.000	0.00
2003/03/13	02:22:35	0.000	0.00
2003/03/13	02:22:40	0.000	0.02
2003/03/13	02:22:45	0.000	-0.02
2003/03/13	02:22:50	0.000	0.01
2003/03/13	02:22:55	0.000	0.01
2003/03/13	02:23:00	0.000	0.01
2003/03/13	02:23:05	0.000	0.01
2003/03/13	02:23:10	0.000	0.03
2003/03/13	02:23:15	0.000	0.02
2003/03/13	02:23:20	0.000	-0.02
2003/03/13	02:23:25	0.000	0.03
2003/03/13	02:23:30	0.000	-0.01
2003/03/13	02:23:35	0.000	0.00
2003/03/13	02:23:40	0.000	0.01
2003/03/13	02:23:45	0.000	-0.01
2003/03/13	02:23:50	0.000	0.01
2003/03/13	02:23:55	0.000	-0.02
2003/03/13	02:24:00	0.000	0.01
2003/03/13	02:24:05	0.000	0.00
2003/03/13	02:24:10	0.000	0.00
2003/03/13	02:24:15	0.000	0.01
2003/03/13	02:24:20	0.000	0.03
2003/03/13	02:24:25	0.000	0.02
2003/03/13	02:24:30	0.000	-0.02
2003/03/13	02:24:35	0.000	0.03
2003/03/13	02:24:40	0.000	0.00
2003/03/13	02:24:45	0.000	-0.01
2003/03/13	02:24:50	0.000	0.01

0.01



0.01



2003/03/13	02:24:55	0.000	-0.01
2003/03/13	02:25:00	0.000	0.00
2003/03/13	02:25:05	0.000	-0.02
2003/03/13	02:25:10	0.000	0.01
2003/03/13	02:25:15	0.000	0.01
2003/03/13	02:25:20	0.000	0.00
2003/03/13	02:25:25	0.000	0.02
2003/03/13	02:25:30	0.000	0.03
2003/03/13	02:25:35	0.000	0.01
2003/03/13	02:25:40	0.000	-0.02
2003/03/13	02:25:45	0.000	0.04
2003/03/13	02:25:50	0.000	0.01
2003/03/13	02:25:55	0.000	-0.01
2003/03/13	02:26:00	0.000	0.02
2003/03/13	02:26:05	0.000	-0.01
2003/03/13	02:26:10	0.000	0.01
2003/03/13	02:26:15	0.000	-0.01
2003/03/13	02:26:20	0.000	0.01
2003/03/13	02:26:25	0.000	0.01
2003/03/13	02:26:30	0.000	-0.01
2003/03/13	02:26:35	0.000	0.02
2003/03/13	02:26:40	0.000	0.02
2003/03/13	02:26:45	0.000	0.01
2003/03/13	02:26:50	0.000	-0.01
2003/03/13	02:26:55	0.000	0.03
2003/03/13	02:27:00	0.000	0.01
2003/03/13	02:27:05	0.000	-0.01
2003/03/13	02:27:10	0.000	0.03
2003/03/13	02:27:15	0.000	-0.02
2003/03/13	02:27:20	0.000	0.01
2003/03/13	02:27:25	0.000	-0.01
2003/03/13	02:27:30	0.000	0.00
2003/03/13	02:27:35	0.000	0.02
2003/03/13	02:27:40	0.000	-0.01
2003/03/13	02:27:45	0.000	0.01
2003/03/13	02:27:50	0.000	0.01
2003/03/13	02:27:55	0.000	0.01
2003/03/13	02:28:00	0.000	0.00
2003/03/13	02:28:05	0.000	0.03
2003/03/13	02:28:10	0.000	0.01
2003/03/13	02:28:15	0.000	-0.02
2003/03/13	02:28:20	0.000	0.03
2003/03/13	02:28:25	0.000	-0.02
2003/03/13	02:28:30	0.000	0.00
2003/03/13	02:28:35	0.000	0.00
2003/03/13	02:28:40	0.000	0.00
2003/03/13	02:28:45	0.000	0.02
2003/03/13	02:28:50	0.000	-0.02
2003/03/13	02:28:55	0.000	0.01
2003/03/13	02:29:00	0.000	0.00
2003/03/13	02:29:05	0.000	0.01
2003/03/13	02:29:10	0.000	0.01
2003/03/13	02:29:15	0.000	0.03
2003/03/13	02:29:20	0.000	-0.02
2003/03/13	02:29:25	0.000	-0.02
2003/03/13	02:29:30	0.000	0.03
2003/03/13	02:29:35	0.000	-0.01
2003/03/13	02:29:40	0.000	0.00
2003/03/13	02:29:45	0.000	0.01
2003/03/13	02:29:50	0.000	-0.01
2003/03/13	02:29:55	0.000	0.01
2003/03/13	02:30:00	0.000	-0.02
2003/03/13	02:30:05	0.000	0.01
2003/03/13	02:30:10	0.000	0.00
2003/03/13	02:30:15	0.000	0.00
2003/03/13	02:30:20	0.000	0.01
2003/03/13	02:30:25	0.000	0.03
2003/03/13	02:30:30	0.000	0.02
2003/03/13	02:30:35	0.000	-0.02
2003/03/13	02:30:40	0.000	0.03
2003/03/13	02:30:45	0.000	0.00
2003/03/13	02:30:50	0.000	-0.01
2003/03/13	02:30:55	0.000	0.02
2003/03/13	02:31:00	0.000	-0.01
2003/03/13	02:31:05	0.000	0.00
2003/03/13	02:31:10	0.000	-0.02
2003/03/13	02:31:15	0.000	0.01
2003/03/13	02:31:20	0.000	0.01
2003/03/13	02:31:25	0.000	-0.01
2003/03/13	02:31:30	0.000	0.02
2003/03/13	02:31:35	0.000	0.03
2003/03/13	02:31:40	0.000	0.01
2003/03/13	02:31:45	0.000	-0.02
2003/03/13	02:31:50	0.000	0.04
2003/03/13	02:31:55	0.000	0.01
2003/03/13	02:32:00	0.000	-0.01
2003/03/13	02:32:05	0.000	0.02
2003/03/13	02:32:10	0.000	-0.01
2003/03/13	02:32:15	0.000	0.01
2003/03/13	02:32:20	0.000	-0.01
2003/03/13	02:32:25	0.000	0.01
2003/03/13	02:32:30	0.000	0.01
2003/03/13	02:32:35	0.000	-0.01
2003/03/13	02:32:40	0.000	0.02
2003/03/13	02:32:45	0.000	0.02
2003/03/13	02:32:50	0.000	0.01
2003/03/13	02:32:55	0.000	-0.01
2003/03/13	02:33:00	0.000	0.03
2003/03/13	02:33:05	0.000	0.01
2003/03/13	02:33:10	0.000	-0.01
2003/03/13	02:33:15	0.000	0.03
2003/03/13	02:33:20	0.000	-0.02
2003/03/13	02:33:25	0.000	0.01
2003/03/13	02:33:30	0.000	-0.01
2003/03/13	02:33:35	0.000	0.00
2003/03/13	02:33:40	0.000	0.02
2003/03/13	02:33:45	0.000	-0.01
2003/03/13	02:33:50	0.000	0.01
2003/03/13	02:33:55	0.000	0.01
2003/03/13	02:34:00	0.000	0.01
2003/03/13	02:34:05	0.000	0.00
2003/03/13	02:34:10	0.000	0.03
2003/03/13	02:34:15	0.000	0.01
2003/03/13	02:34:20	0.000	-0.02
2003/03/13	02:34:25	0.000	0.03
2003/03/13	02:34:30	0.000	-0.02
2003/03/13	02:34:35	0.000	0.00
2003/03/13	02:34:40	0.000	0.00
2003/03/13	02:34:45	0.000	0.00
2003/03/13	02:34:50	0.000	0.02
2003/03/13	02:34:55	0.000	-0.02
2003/03/13	02:35:00	0.000	0.01
2003/03/13	02:35:05	0.000	0.00
2003/03/13	02:35:10	0.000	0.01
2003/03/13	02:35:15	0.000	0.01
2003/03/13	02:35:20	0.000	0.03
2003/03/13	02:35:25	0.000	0.02
2003/03/13	02:35:30	0.000	-0.02
2003/03/13	02:35:35	0.000	0.03
2003/03/13	02:35:40	0.000	-0.01
2003/03/13	02:35:45	0.000	0.00
2003/03/13	02:35:50	0.000	0.01
2003/03/13	02:35:55	0.000	-0.01
2003/03/13	02:36:00	0.000	0.01

0.01

2003/03/13 02:24:55

0.01

2003/03/13 02:30:00

0.01

2003/03/13 02:35:00

2003/03/13	02:38:06	0.000	-0.02
2003/03/13	02:38:10	0.000	0.01
2003/03/13	02:38:15	0.000	0.00
2003/03/13	02:38:20	0.000	0.00
2003/03/13	02:38:25	0.000	0.01
2003/03/13	02:38:30	0.000	0.03
2003/03/13	02:38:35	0.000	0.02
2003/03/13	02:38:40	0.000	-0.02
2003/03/13	02:38:45	0.000	0.03
2003/03/13	02:38:50	0.000	0.00
2003/03/13	02:38:55	0.000	-0.01
2003/03/13	02:39:00	0.000	0.02
2003/03/13	02:39:05	0.000	-0.01
2003/03/13	02:39:10	0.000	0.00
2003/03/13	02:39:15	0.000	-0.02
2003/03/13	02:39:20	0.000	0.01
2003/03/13	02:39:25	0.000	0.01
2003/03/13	02:39:30	0.000	-0.01
2003/03/13	02:39:35	0.000	0.02
2003/03/13	02:39:40	0.000	0.03
2003/03/13	02:39:45	0.000	0.01
2003/03/13	02:39:50	0.000	-0.02
2003/03/13	02:39:55	0.000	0.01
2003/03/13	02:40:00	0.000	-0.01
2003/03/13	02:40:05	0.000	0.02
2003/03/13	02:40:10	0.000	0.03
2003/03/13	02:40:15	0.000	0.01
2003/03/13	02:40:20	0.000	-0.02
2003/03/13	02:40:25	0.000	0.03
2003/03/13	02:40:30	0.000	-0.02
2003/03/13	02:40:35	0.000	0.00
2003/03/13	02:40:40	0.000	0.00
2003/03/13	02:40:45	0.000	0.00
2003/03/13	02:40:50	0.000	0.02
2003/03/13	02:40:55	0.000	-0.02
2003/03/13	02:41:00	0.000	0.01
2003/03/13	02:41:05	0.000	0.00
2003/03/13	02:41:10	0.000	0.01
2003/03/13	02:41:15	0.000	0.01
2003/03/13	02:41:20	0.000	0.03
2003/03/13	02:41:25	0.000	0.02
2003/03/13	02:41:30	0.000	-0.02
2003/03/13	02:41:35	0.000	0.03
2003/03/13	02:41:40	0.000	-0.01
2003/03/13	02:41:45	0.000	0.00
2003/03/13	02:41:50	0.000	0.01
2003/03/13	02:41:55	0.000	-0.01
2003/03/13	02:42:00	0.000	0.01
2003/03/13	02:42:05	0.000	-0.02
2003/03/13	02:42:10	0.000	0.01
2003/03/13	02:42:15	0.000	0.00
2003/03/13	02:42:20	0.000	0.00
2003/03/13	02:42:25	0.000	0.01
2003/03/13	02:42:30	0.000	0.03
2003/03/13	02:42:35	0.000	0.02
2003/03/13	02:42:40	0.000	-0.02
2003/03/13	02:42:45	0.000	0.03
2003/03/13	02:42:50	0.000	0.00
2003/03/13	02:42:55	0.000	-0.01
2003/03/13	02:43:00	0.000	0.02
2003/03/13	02:43:05	0.000	0.02
2003/03/13	02:43:10	0.000	-0.01
2003/03/13	02:43:15	0.000	0.00
2003/03/13	02:43:20	0.000	-0.02
2003/03/13	02:43:25	0.000	0.01
2003/03/13	02:43:30	0.000	0.01
2003/03/13	02:43:35	0.000	-0.01
2003/03/13	02:43:40	0.000	0.02
2003/03/13	02:43:45	0.000	0.03
2003/03/13	02:43:50	0.000	0.01
2003/03/13	02:43:55	0.000	-0.02
2003/03/13	02:44:00	0.000	0.04
2003/03/13	02:44:05	0.000	0.00
2003/03/13	02:44:10	0.000	-0.01
2003/03/13	02:44:15	0.000	0.02
2003/03/13	02:44:20	0.000	-0.01
2003/03/13	02:44:25	0.000	0.01
2003/03/13	02:44:30	0.000	-0.01
2003/03/13	02:44:35	0.000	0.02
2003/03/13	02:44:40	0.000	0.02
2003/03/13	02:44:45	0.000	0.01
2003/03/13	02:44:50	0.000	0.01
2003/03/13	02:44:55	0.000	0.02
2003/03/13	02:45:00	0.000	0.01
2003/03/13	02:45:05	0.000	-0.01
2003/03/13	02:45:10	0.000	0.03
2003/03/13	02:45:15	0.000	0.01
2003/03/13	02:45:20	0.000	-0.01
2003/03/13	02:45:25	0.000	0.03
2003/03/13	02:45:30	0.000	-0.02
2003/03/13	02:45:35	0.000	0.01
2003/03/13	02:45:40	0.000	-0.01
2003/03/13	02:45:45	0.000	0.00
2003/03/13	02:45:50	0.000	0.02
2003/03/13	02:45:55	0.000	-0.01
2003/03/13	02:46:00	0.000	0.01
2003/03/13	02:46:05	0.000	0.01
2003/03/13	02:46:10	0.000	0.00
2003/03/13	02:46:15	0.000	0.03
2003/03/13	02:46:20	0.000	0.01
2003/03/13	02:46:25	0.000	-0.02
2003/03/13	02:46:30	0.000	0.03
2003/03/13	02:46:35	0.000	0.03
2003/03/13	02:46:40	0.000	-0.02
2003/03/13	02:46:45	0.000	0.00
2003/03/13	02:46:50	0.000	0.00
2003/03/13	02:46:55	0.000	0.02
2003/03/13	02:47:00	0.000	-0.02
2003/03/13	02:47:05	0.000	0.01

0.01

02:40:05 02:40:10

0.01

02:45:05 02:45:10

2003/03/13	02:47:18	0.000	0.00
2003/03/13	02:47:20	0.000	0.01
2003/03/13	02:47:28	0.000	0.01
2003/03/13	02:47:30	0.000	0.03
2003/03/13	02:47:35	0.000	0.02
2003/03/13	02:47:40	0.000	-0.02
2003/03/13	02:47:45	0.000	0.03
2003/03/13	02:47:50	0.000	-0.01
2003/03/13	02:47:55	0.000	0.00
2003/03/13	02:48:00	0.000	0.01
2003/03/13	02:48:05	0.000	-0.01
2003/03/13	02:48:10	0.000	0.01
2003/03/13	02:48:15	0.000	-0.02
2003/03/13	02:48:20	0.000	0.01
2003/03/13	02:48:25	0.000	0.00
2003/03/13	02:48:30	0.000	0.00
2003/03/13	02:48:35	0.000	0.01
2003/03/13	02:48:40	0.000	0.01
2003/03/13	02:48:45	0.000	0.03
2003/03/13	02:48:50	0.000	0.02
2003/03/13	02:48:55	0.000	0.03
2003/03/13	02:49:00	0.000	0.00
2003/03/13	02:49:05	0.000	0.00
2003/03/13	02:49:10	0.000	0.02
2003/03/13	02:49:15	0.000	-0.01
2003/03/13	02:49:20	0.000	0.00
2003/03/13	02:49:25	0.000	-0.02
2003/03/13	02:49:30	0.000	0.01
2003/03/13	02:49:35	0.000	0.01
2003/03/13	02:49:40	0.000	-0.01
2003/03/13	02:49:45	0.000	0.02
2003/03/13	02:49:50	0.000	0.03
2003/03/13	02:49:55	0.000	0.01
2003/03/13	02:50:00	0.000	-0.02
2003/03/13	02:50:05	0.000	0.04
2003/03/13	02:50:10	0.000	0.00
2003/03/13	02:50:15	0.000	-0.01
2003/03/13	02:50:20	0.000	0.02
2003/03/13	02:50:25	0.000	-0.01
2003/03/13	02:50:30	0.000	0.01
2003/03/13	02:50:35	0.000	-0.01
2003/03/13	02:50:40	0.000	0.01
2003/03/13	02:50:45	0.000	0.01
2003/03/13	02:50:50	0.000	-0.01
2003/03/13	02:50:55	0.000	0.02
2003/03/13	02:51:00	0.000	0.02
2003/03/13	02:51:05	0.000	0.01
2003/03/13	02:51:10	0.000	0.00
2003/03/13	02:51:15	0.000	0.04
2003/03/13	02:51:20	0.000	0.03
2003/03/13	02:51:25	0.000	0.00
2003/03/13	02:51:30	0.000	0.04
2003/03/13	02:51:35	0.000	0.00
2003/03/13	02:51:40	0.000	0.03
2003/03/13	02:51:45	0.000	0.02
2003/03/13	02:51:50	0.000	0.03
2003/03/13	02:51:55	0.000	0.04
2003/03/13	02:52:00	0.000	0.02
2003/03/13	02:52:05	0.000	0.04
2003/03/13	02:52:10	0.000	0.04
2003/03/13	02:52:15	0.000	0.04
2003/03/13	02:52:20	0.000	0.03
2003/03/13	02:52:25	0.000	0.06
2003/03/13	02:52:30	0.000	0.03
2003/03/13	02:52:35	0.000	-0.01
2003/03/13	02:52:40	0.000	0.03
2003/03/13	02:52:45	0.000	-0.02
2003/03/13	02:52:50	0.000	0.00
2003/03/13	02:52:55	0.000	0.00
2003/03/13	02:53:00	0.000	0.00
2003/03/13	02:53:05	0.000	0.02
2003/03/13	02:53:10	0.000	-0.02
2003/03/13	02:53:15	0.000	0.01
2003/03/13	02:53:20	0.000	0.00
2003/03/13	02:53:25	0.000	0.01
2003/03/13	02:53:30	0.000	0.01
2003/03/13	02:53:35	0.000	0.03
2003/03/13	02:53:40	0.000	0.04
2003/03/13	02:53:45	0.000	0.01
2003/03/13	02:53:50	0.000	0.07
2003/03/13	02:53:55	0.000	0.02
2003/03/13	02:54:00	0.000	0.04
2003/03/13	02:54:05	0.000	0.05
2003/03/13	02:54:10	0.000	0.04
2003/03/13	02:54:15	0.000	0.04
2003/03/13	02:54:20	0.000	0.00
2003/03/13	02:54:25	0.000	0.01
2003/03/13	02:54:30	0.000	0.00
2003/03/13	02:54:35	0.000	0.00
2003/03/13	02:54:40	0.000	0.01
2003/03/13	02:54:45	0.000	0.03
2003/03/13	02:54:50	0.000	0.02
2003/03/13	02:54:55	0.000	-0.02
2003/03/13	02:55:00	0.000	0.03
2003/03/13	02:55:05	0.000	0.00
2003/03/13	02:55:10	0.000	0.00
2003/03/13	02:55:15	0.000	0.02
2003/03/13	02:55:20	0.000	-0.01
2003/03/13	02:55:25	0.000	0.00
2003/03/13	02:55:30	0.000	-0.02
2003/03/13	02:55:35	0.000	0.01
2003/03/13	02:55:40	0.000	0.01
2003/03/13	02:55:45	0.000	-0.01
2003/03/13	02:55:50	0.000	0.02
2003/03/13	02:55:55	0.000	0.03
2003/03/13	02:56:00	0.000	0.01
2003/03/13	02:56:05	0.000	-0.02
2003/03/13	02:56:10	0.000	0.04
2003/03/13	02:56:15	0.000	0.00
2003/03/13	02:56:20	0.000	-0.01
2003/03/13	02:56:25	0.000	0.02
2003/03/13	02:56:30	0.000	-0.01
2003/03/13	02:56:35	0.000	0.01
2003/03/13	02:56:40	0.000	-0.01
2003/03/13	02:56:45	0.000	0.01
2003/03/13	02:56:50	0.000	0.01
2003/03/13	02:56:55	0.000	-0.01
2003/03/13	02:57:00	0.000	0.02
2003/03/13	02:57:05	0.000	0.02
2003/03/13	02:57:10	0.000	0.01
2003/03/13	02:57:15	0.000	-0.01
2003/03/13	02:57:20	0.000	0.03
2003/03/13	02:57:25	0.000	0.01
2003/03/13	02:57:30	0.000	-0.01
2003/03/13	02:57:35	0.000	0.03
2003/03/13	02:57:40	0.000	-0.02
2003/03/13	02:57:45	0.000	0.01
2003/03/13	02:57:50	0.000	-0.01
2003/03/13	02:57:55	0.000	0.00
2003/03/13	02:58:00	0.000	0.02
2003/03/13	02:58:05	0.000	-0.01
2003/03/13	02:58:10	0.000	0.01
2003/03/13	02:58:15	0.000	0.01
2003/03/13	02:58:20	0.000	0.01

0.01

RESERVED FOR INTERNAL USE

0.02

RESERVED FOR INTERNAL USE

2003/03/13	02:58:25	0.000	0.00
2003/03/13	02:58:30	0.000	0.03
2003/03/13	02:58:35	0.000	0.01
2003/03/13	02:58:40	0.000	-0.02
2003/03/13	02:58:45	0.000	0.03
2003/03/13	02:58:50	0.000	-0.02
2003/03/13	02:58:55	0.000	0.00
2003/03/13	02:59:00	0.000	0.00
2003/03/13	02:59:05	0.000	0.00
2003/03/13	02:59:10	0.000	0.02
2003/03/13	02:59:15	0.000	-0.02
2003/03/13	02:59:20	0.000	0.01
2003/03/13	02:59:25	0.000	0.01
2003/03/13	02:59:30	0.000	0.01
2003/03/13	02:59:35	0.000	0.01
2003/03/13	02:59:40	0.000	0.03
2003/03/13	02:59:45	0.000	0.02
2003/03/13	02:59:50	0.000	-0.02
2003/03/13	02:59:55	0.000	0.03
2003/03/13	03:00:00	0.000	-0.01
2003/03/13	03:00:05	0.000	0.00
2003/03/13	03:00:10	0.000	0.01
2003/03/13	03:00:15	0.000	-0.01
2003/03/13	03:00:20	0.000	0.01
2003/03/13	03:00:25	0.000	-0.02
2003/03/13	03:00:30	0.000	0.01
2003/03/13	03:00:35	0.000	0.00
2003/03/13	03:00:40	0.000	0.00
2003/03/13	03:00:45	0.000	0.01
2003/03/13	03:00:50	0.000	0.03
2003/03/13	03:00:55	0.000	0.02
2003/03/13	03:01:00	0.000	-0.02
2003/03/13	03:01:05	0.000	0.03
2003/03/13	03:01:10	0.000	0.00
2003/03/13	03:01:15	0.000	0.00
2003/03/13	03:01:20	0.000	0.01
2003/03/13	03:01:25	0.000	-0.01
2003/03/13	03:01:30	0.000	0.00
2003/03/13	03:01:35	0.000	-0.02
2003/03/13	03:01:40	0.000	0.01
2003/03/13	03:01:45	0.000	0.01
2003/03/13	03:01:50	0.000	-0.01
2003/03/13	03:01:55	0.000	0.02
2003/03/13	03:02:00	0.000	0.03
2003/03/13	03:02:05	0.000	0.01
2003/03/13	03:02:10	0.000	-0.02
2003/03/13	03:02:15	0.000	0.04
2003/03/13	03:02:20	0.000	0.00
2003/03/13	03:02:25	0.000	-0.01
2003/03/13	03:02:30	0.000	0.02
2003/03/13	03:02:35	0.000	-0.01
2003/03/13	03:02:40	0.000	0.01
2003/03/13	03:02:45	0.000	-0.01
2003/03/13	03:02:50	0.000	0.01
2003/03/13	03:02:55	0.000	0.01
2003/03/13	03:03:00	0.000	-0.01
2003/03/13	03:03:05	0.000	0.02
2003/03/13	03:03:10	0.000	0.02
2003/03/13	03:03:15	0.000	0.01
2003/03/13	03:03:20	0.000	-0.01
2003/03/13	03:03:25	0.000	0.03
2003/03/13	03:03:30	0.000	0.01
2003/03/13	03:03:35	0.000	-0.01
2003/03/13	03:03:40	0.000	0.03
2003/03/13	03:03:45	0.000	-0.02
2003/03/13	03:03:50	0.000	0.01
2003/03/13	03:03:55	0.000	-0.01
2003/03/13	03:04:00	0.000	0.00
2003/03/13	03:04:05	0.000	0.02
2003/03/13	03:04:10	0.000	-0.01
2003/03/13	03:04:15	0.000	0.01
2003/03/13	03:04:20	0.000	0.01
2003/03/13	03:04:25	0.000	0.01
2003/03/13	03:04:30	0.000	0.00
2003/03/13	03:04:35	0.000	0.03
2003/03/13	03:04:40	0.000	0.01
2003/03/13	03:04:45	0.000	-0.02
2003/03/13	03:04:50	0.000	0.03
2003/03/13	03:04:55	0.000	-0.02
2003/03/13	03:05:00	0.000	0.00
2003/03/13	03:05:05	0.000	0.00
2003/03/13	03:05:10	0.000	0.00
2003/03/13	03:05:15	0.000	0.02
2003/03/13	03:05:20	0.000	-0.02
2003/03/13	03:05:25	0.000	0.01
2003/03/13	03:05:30	0.000	0.01
2003/03/13	03:05:35	0.000	0.01
2003/03/13	03:05:40	0.000	0.01
2003/03/13	03:05:45	0.000	0.03
2003/03/13	03:05:50	0.000	0.02
2003/03/13	03:05:55	0.000	-0.02
2003/03/13	03:06:00	0.000	0.03
2003/03/13	03:06:05	0.000	-0.01
2003/03/13	03:06:10	0.000	0.00
2003/03/13	03:06:15	0.000	0.01
2003/03/13	03:06:20	0.000	-0.01
2003/03/13	03:06:25	0.000	0.01
2003/03/13	03:06:30	0.000	-0.02
2003/03/13	03:06:35	0.000	0.01
2003/03/13	03:06:40	0.000	0.00
2003/03/13	03:06:45	0.000	0.00
2003/03/13	03:06:50	0.000	0.01
2003/03/13	03:06:55	0.000	0.03
2003/03/13	03:07:00	0.000	0.02
2003/03/13	03:07:05	0.000	-0.02
2003/03/13	03:07:10	0.000	0.03
2003/03/13	03:07:15	0.000	0.00
2003/03/13	03:07:20	0.000	0.00
2003/03/13	03:07:25	0.000	0.01
2003/03/13	03:07:30	0.000	-0.01
2003/03/13	03:07:35	0.000	0.00
2003/03/13	03:07:40	0.000	-0.02
2003/03/13	03:07:45	0.000	0.01
2003/03/13	03:07:50	0.000	0.01
2003/03/13	03:07:55	0.000	0.00
2003/03/13	03:08:00	0.000	0.02
2003/03/13	03:08:05	0.000	0.03
2003/03/13	03:08:10	0.000	0.01
2003/03/13	03:08:15	0.000	-0.02
2003/03/13	03:08:20	0.000	0.04
2003/03/13	03:08:25	0.000	-0.00
2003/03/13	03:08:30	0.000	-0.01
2003/03/13	03:08:35	0.000	0.02
2003/03/13	03:08:40	0.000	-0.01
2003/03/13	03:08:45	0.000	0.01
2003/03/13	03:08:50	0.000	-0.01
2003/03/13	03:08:55	0.000	0.01
2003/03/13	03:09:00	0.000	0.01
2003/03/13	03:09:05	0.000	-0.01
2003/03/13	03:09:10	0.000	0.02
2003/03/13	03:09:15	0.000	0.02
2003/03/13	03:09:20	0.000	0.01
2003/03/13	03:09:25	0.000	-0.01
2003/03/13	03:09:30	0.000	0.03

0.01

20030313 03:00:00

0.00

20030313 03:00:00

2003/03/18	03:09:35	0.000	0.01
2003/03/13	03:09:40	0.000	-0.01
2003/03/13	03:09:45	0.000	0.03
2003/03/13	03:09:50	0.000	-0.02
2003/03/13	03:09:55	0.000	0.01
2003/03/18	03:10:00	0.000	-0.01
2003/03/18	03:10:05	0.000	0.00
2003/03/13	03:10:10	0.000	0.02
2003/03/13	03:10:15	0.000	-0.01
2003/03/13	03:10:20	0.000	0.01
2003/03/13	03:10:25	0.000	0.01
2003/03/13	03:10:30	0.000	0.01
2003/03/18	03:10:35	0.000	0.00
2003/03/13	03:10:40	0.000	0.03
2003/03/13	03:10:45	0.000	0.01
2003/03/13	03:10:50	0.000	-0.02
2003/03/13	03:10:55	0.000	0.03
2003/03/13	03:11:00	0.000	-0.02
2003/03/18	03:11:05	0.000	0.00
2003/03/13	03:11:10	0.000	0.00
2003/03/13	03:11:15	0.000	0.00
2003/03/13	03:11:20	0.000	0.02
2003/03/13	03:11:25	0.000	-0.01
2003/03/18	03:11:30	0.000	0.01
2003/03/13	03:11:35	0.000	0.01
2003/03/13	03:11:40	0.000	0.01
2003/03/13	03:11:45	0.000	0.00
2003/03/13	03:11:50	0.000	0.03
2003/03/13	03:11:55	0.000	0.02
2003/03/18	03:12:00	0.000	-0.02
2003/03/13	03:12:05	0.000	0.03
2003/03/13	03:12:10	0.000	-0.01
2003/03/13	03:12:15	0.000	0.00
2003/03/13	03:12:20	0.000	0.01
2003/03/13	03:12:25	0.000	-0.01
2003/03/13	03:12:30	0.000	0.01
2003/03/13	03:12:35	0.000	-0.02
2003/03/18	03:12:40	0.000	0.01
2003/03/13	03:12:45	0.000	0.00
2003/03/13	03:12:50	0.000	0.00
2003/03/13	03:12:55	0.000	0.01
2003/03/13	03:13:00	0.000	0.03
2003/03/13	03:13:05	0.000	0.02
2003/03/13	03:13:10	0.000	-0.02
2003/03/13	03:13:15	0.000	0.03
2003/03/13	03:13:20	0.000	0.00
2003/03/13	03:13:25	0.000	0.00
2003/03/13	03:13:30	0.000	0.01
2003/03/13	03:13:35	0.000	-0.01
2003/03/13	03:13:40	0.000	0.00
2003/03/13	03:13:45	0.000	-0.02
2003/03/13	03:13:50	0.000	0.01
2003/03/13	03:13:55	0.000	0.01
2003/03/13	03:14:00	0.000	0.00
2003/03/13	03:14:05	0.000	0.02
2003/03/13	03:14:10	0.000	0.03
2003/03/13	03:14:15	0.000	0.01
2003/03/13	03:14:20	0.000	-0.02
2003/03/13	03:14:25	0.000	0.04
2003/03/13	03:14:30	0.000	0.00
2003/03/13	03:14:35	0.000	-0.01
2003/03/13	03:14:40	0.000	0.02
2003/03/13	03:14:45	0.000	-0.01
2003/03/13	03:14:50	0.000	0.01
2003/03/13	03:14:55	0.000	-0.01
2003/03/13	03:15:00	0.000	0.01
2003/03/13	03:15:05	0.000	0.01
2003/03/13	03:15:10	0.000	-0.01
2003/03/13	03:15:15	0.000	0.02
2003/03/13	03:15:20	0.000	0.02
2003/03/13	03:15:25	0.000	0.01
2003/03/13	03:15:30	0.000	-0.01
2003/03/13	03:15:35	0.000	0.03
2003/03/13	03:15:40	0.000	0.01
2003/03/13	03:15:45	0.000	-0.01
2003/03/13	03:15:50	0.000	0.03
2003/03/13	03:15:55	0.000	-0.02
2003/03/13	03:16:00	0.000	0.01
2003/03/13	03:16:05	0.000	-0.01
2003/03/13	03:16:10	0.000	0.00
2003/03/13	03:16:15	0.000	0.02
2003/03/13	03:16:20	0.000	-0.01
2003/03/13	03:16:25	0.000	0.01
2003/03/13	03:16:30	0.000	0.02
2003/03/13	03:16:35	0.000	0.01
2003/03/13	03:16:40	0.000	0.00
2003/03/13	03:16:45	0.000	0.03
2003/03/13	03:16:50	0.000	0.01
2003/03/13	03:16:55	0.000	-0.01
2003/03/13	03:17:00	0.000	0.03
2003/03/13	03:17:05	0.000	-0.02
2003/03/13	03:17:10	0.000	0.00
2003/03/13	03:17:15	0.000	0.00
2003/03/13	03:17:20	0.000	0.00
2003/03/13	03:17:25	0.000	0.02
2003/03/13	03:17:30	0.000	-0.02
2003/03/13	03:17:35	0.000	0.01
2003/03/13	03:17:40	0.000	0.01
2003/03/13	03:17:45	0.000	0.01
2003/03/13	03:17:50	0.000	0.00
2003/03/13	03:17:55	0.000	0.03
2003/03/13	03:18:00	0.000	0.02
2003/03/13	03:18:05	0.000	-0.02
2003/03/13	03:18:10	0.000	0.03
2003/03/13	03:18:15	0.000	-0.01
2003/03/13	03:18:20	0.000	0.00
2003/03/13	03:18:25	0.000	0.01
2003/03/13	03:18:30	0.000	-0.01
2003/03/13	03:18:35	0.000	0.01
2003/03/13	03:18:40	0.000	0.01
2003/03/13	03:18:45	0.000	-0.01
2003/03/13	03:18:50	0.000	0.02
2003/03/13	03:18:55	0.000	0.00
2003/03/13	03:19:00	0.000	0.00
2003/03/13	03:19:05	0.000	0.03
2003/03/13	03:19:10	0.000	0.02
2003/03/13	03:19:15	0.000	-0.02
2003/03/13	03:19:20	0.000	0.03
2003/03/13	03:19:25	0.000	-0.01
2003/03/13	03:19:30	0.000	0.00
2003/03/13	03:19:35	0.000	0.01
2003/03/13	03:19:40	0.000	-0.01
2003/03/13	03:19:45	0.000	0.00
2003/03/13	03:19:50	0.000	-0.02
2003/03/13	03:19:55	0.000	0.01
2003/03/13	03:20:00	0.000	0.01
2003/03/13	03:20:05	0.000	0.00
2003/03/13	03:20:10	0.000	0.02
2003/03/13	03:20:15	0.000	0.03
2003/03/13	03:20:20	0.000	0.01
2003/03/13	03:20:25	0.000	-0.02
2003/03/13	03:20:30	0.000	0.04
2003/03/13	03:20:35	0.000	0.00
2003/03/13	03:20:40	0.000	-0.01

0.01

2003/03/18 03:09:35

0.01

2003/03/18 03:15:00

0.01

2003/03/18 03:20:00

2003/03/13	03:20:48	0.000	0.02
2003/03/13	03:20:50	0.000	-0.01
2003/03/13	03:20:55	0.000	0.01
2003/03/13	03:21:00	0.000	-0.02
2003/03/13	03:21:05	0.000	0.01
2003/03/13	03:21:10	0.000	0.01
2003/03/13	03:21:15	0.000	-0.01
2003/03/13	03:21:20	0.000	0.02
2003/03/13	03:21:25	0.000	0.02
2003/03/13	03:21:30	0.000	0.01
2003/03/13	03:21:35	0.000	-0.01
2003/03/13	03:21:40	0.000	0.03
2003/03/13	03:21:45	0.000	0.01
2003/03/13	03:21:50	0.000	-0.01
2003/03/13	03:21:55	0.000	0.03
2003/03/13	03:22:00	0.000	-0.02
2003/03/13	03:22:05	0.000	0.01
2003/03/13	03:22:10	0.000	-0.01
2003/03/13	03:22:15	0.000	0.01
2003/03/13	03:22:20	0.000	0.02
2003/03/13	03:22:25	0.000	-0.01
2003/03/13	03:22:30	0.000	0.01
2003/03/13	03:22:35	0.000	0.02
2003/03/13	03:22:40	0.000	0.01
2003/03/13	03:22:45	0.000	-0.01
2003/03/13	03:22:50	0.000	0.03
2003/03/13	03:22:55	0.000	0.01
2003/03/13	03:23:00	0.000	-0.01
2003/03/13	03:23:05	0.000	0.03
2003/03/13	03:23:10	0.000	-0.02
2003/03/13	03:23:15	0.000	0.00
2003/03/13	03:23:20	0.000	0.00
2003/03/13	03:23:25	0.000	0.00
2003/03/13	03:23:30	0.000	0.02
2003/03/13	03:23:35	0.000	-0.01
2003/03/13	03:23:40	0.000	0.01
2003/03/13	03:23:45	0.000	0.01
2003/03/13	03:23:50	0.000	0.01
2003/03/13	03:23:55	0.000	0.00
2003/03/13	03:24:00	0.000	0.03
2003/03/13	03:24:05	0.000	0.02
2003/03/13	03:24:10	0.000	-0.02
2003/03/13	03:24:15	0.000	0.03
2003/03/13	03:24:20	0.000	-0.02
2003/03/13	03:24:25	0.000	0.00
2003/03/13	03:24:30	0.000	0.00
2003/03/13	03:24:35	0.000	-0.01
2003/03/13	03:24:40	0.000	0.01
2003/03/13	03:24:45	0.000	-0.01
2003/03/13	03:24:50	0.000	0.02
2003/03/13	03:24:55	0.000	0.00
2003/03/13	03:25:00	0.000	0.00
2003/03/13	03:25:05	0.000	0.01
2003/03/13	03:25:10	0.000	0.03
2003/03/13	03:25:15	0.000	0.02
2003/03/13	03:25:20	0.000	-0.02
2003/03/13	03:25:25	0.000	0.03
2003/03/13	03:25:30	0.000	-0.01
2003/03/13	03:25:35	0.000	0.00
2003/03/13	03:25:40	0.000	0.01
2003/03/13	03:25:45	0.000	-0.01
2003/03/13	03:25:50	0.000	0.01
2003/03/13	03:25:55	0.000	-0.01
2003/03/13	03:26:00	0.000	0.02
2003/03/13	03:26:05	0.000	0.01
2003/03/13	03:26:10	0.000	0.03
2003/03/13	03:26:15	0.000	0.02
2003/03/13	03:26:20	0.000	-0.02
2003/03/13	03:26:25	0.000	0.03
2003/03/13	03:26:30	0.000	-0.01
2003/03/13	03:26:35	0.000	0.00
2003/03/13	03:26:40	0.000	0.01
2003/03/13	03:26:45	0.000	-0.01
2003/03/13	03:26:50	0.000	0.05
2003/03/13	03:26:55	0.000	0.02
2003/03/13	03:27:00	0.000	0.05
2003/03/13	03:27:05	0.000	0.02
2003/03/13	03:27:10	0.000	0.05
2003/03/13	03:27:15	0.000	0.05
2003/03/13	03:27:20	0.000	0.03
2003/03/13	03:27:25	0.000	0.07
2003/03/13	03:27:30	0.000	0.08
2003/03/13	03:27:35	0.000	0.05
2003/03/13	03:27:40	0.000	0.03
2003/03/13	03:27:45	0.000	0.09
2003/03/13	03:27:50	0.000	0.05
2003/03/13	03:27:55	0.000	0.04
2003/03/13	03:28:00	0.000	0.08
2003/03/13	03:28:05	0.000	0.04
2003/03/13	03:28:10	0.000	0.08
2003/03/13	03:28:15	0.000	0.05
2003/03/13	03:28:20	0.000	0.07
2003/03/13	03:28:25	0.000	0.03
2003/03/13	03:28:30	0.000	0.05
2003/03/13	03:28:35	0.000	0.08
2003/03/13	03:28:40	0.000	0.09
2003/03/13	03:28:45	0.000	0.08
2003/03/13	03:28:50	0.000	0.08
2003/03/13	03:28:55	0.000	0.10
2003/03/13	03:29:00	0.000	0.08
2003/03/13	03:29:05	0.000	0.02
2003/03/13	03:29:10	0.000	0.03
2003/03/13	03:29:15	0.000	-0.02
2003/03/13	03:29:20	0.000	0.00
2003/03/13	03:29:25	0.000	0.00
2003/03/13	03:29:30	0.000	0.00
2003/03/13	03:29:35	0.000	0.02
2003/03/13	03:29:40	0.000	-0.01
2003/03/13	03:29:45	0.000	0.01
2003/03/13	03:29:50	0.000	0.01
2003/03/13	03:29:55	0.000	0.01
2003/03/13	03:30:00	0.000	0.02
2003/03/13	03:30:05	0.000	0.08
2003/03/13	03:30:10	0.000	0.08
2003/03/13	03:30:15	0.000	0.05
2003/03/13	03:30:20	0.000	0.11
2003/03/13	03:30:25	0.000	0.08
2003/03/13	03:30:30	0.000	0.08
2003/03/13	03:30:35	0.000	0.08
2003/03/13	03:30:40	0.000	0.07
2003/03/13	03:30:45	0.000	0.08
2003/03/13	03:30:50	0.000	0.01
2003/03/13	03:30:55	0.000	0.02
2003/03/13	03:31:00	0.000	0.00
2003/03/13	03:31:05	0.000	0.00
2003/03/13	03:31:10	0.000	0.01
2003/03/13	03:31:15	0.000	0.03
2003/03/13	03:31:20	0.000	0.02
2003/03/13	03:31:25	0.000	-0.02
2003/03/13	03:31:30	0.000	-0.03
2003/03/13	03:31:35	0.000	-0.01
2003/03/13	03:31:40	0.000	0.00
2003/03/13	03:31:45	0.000	0.01
2003/03/13	03:31:50	0.000	-0.01

0.01

██████████

0.03

██████████

2003/03/13	03:31:55	0.000	0.00
2003/03/13	03:32:00	0.000	-0.02
2003/03/13	03:32:05	0.000	0.01
2003/03/13	03:32:10	0.000	0.00
2003/03/13	03:32:15	0.000	0.00
2003/03/13	03:32:20	0.000	0.02
2003/03/13	03:32:25	0.000	0.03
2003/03/13	03:32:30	0.000	0.01
2003/03/13	03:32:35	0.000	-0.02
2003/03/13	03:32:40	0.000	0.03
2003/03/13	03:32:45	0.000	0.00
2003/03/13	03:32:50	0.000	-0.01
2003/03/13	03:32:55	0.000	0.02
2003/03/13	03:33:00	0.000	-0.01
2003/03/13	03:33:05	0.000	0.01
2003/03/13	03:33:10	0.000	-0.02
2003/03/13	03:33:15	0.000	0.01
2003/03/13	03:33:20	0.000	0.01
2003/03/13	03:33:25	0.000	0.00
2003/03/13	03:33:30	0.000	0.02
2003/03/13	03:33:35	0.000	0.03
2003/03/13	03:33:40	0.000	0.01
2003/03/13	03:33:45	0.000	-0.01
2003/03/13	03:33:50	0.000	0.03
2003/03/13	03:33:55	0.000	0.00
2003/03/13	03:34:00	0.000	-0.01
2003/03/13	03:34:05	0.000	0.02
2003/03/13	03:34:10	0.000	-0.01
2003/03/13	03:34:15	0.000	0.01
2003/03/13	03:34:20	0.000	-0.01
2003/03/13	03:34:25	0.000	0.01
2003/03/13	03:34:30	0.000	0.01
2003/03/13	03:34:35	0.000	-0.01
2003/03/13	03:34:40	0.000	0.01
2003/03/13	03:34:45	0.000	0.02
2003/03/13	03:34:50	0.000	0.01
2003/03/13	03:34:55	0.000	-0.01
2003/03/13	03:35:00	0.000	0.03
2003/03/13	03:35:05	0.000	0.01
2003/03/13	03:35:10	0.000	-0.01
2003/03/13	03:35:15	0.000	0.03
2003/03/13	03:35:20	0.000	-0.02
2003/03/13	03:35:25	0.000	0.00
2003/03/13	03:35:30	0.000	-0.01
2003/03/13	03:35:35	0.000	0.00
2003/03/13	03:35:40	0.000	0.02
2003/03/13	03:35:45	0.000	-0.01
2003/03/13	03:35:50	0.000	0.01
2003/03/13	03:35:55	0.000	0.01
2003/03/13	03:36:00	0.000	0.01
2003/03/13	03:36:05	0.000	0.00
2003/03/13	03:36:10	0.000	0.03
2003/03/13	03:36:15	0.000	0.02
2003/03/13	03:36:20	0.000	-0.02
2003/03/13	03:36:25	0.000	0.03
2003/03/13	03:36:30	0.000	-0.02
2003/03/13	03:36:35	0.000	0.00
2003/03/13	03:36:40	0.000	0.00
2003/03/13	03:36:45	0.000	0.00
2003/03/13	03:36:50	0.000	0.01
2003/03/13	03:36:55	0.000	-0.01
2003/03/13	03:37:00	0.000	0.02
2003/03/13	03:37:05	0.000	0.00
2003/03/13	03:37:10	0.000	0.01
2003/03/13	03:37:15	0.000	0.00
2003/03/13	03:37:20	0.000	0.03
2003/03/13	03:37:25	0.000	0.02
2003/03/13	03:37:30	0.000	-0.02
2003/03/13	03:37:35	0.000	0.03
2003/03/13	03:37:40	0.000	-0.01
2003/03/13	03:37:45	0.000	0.00
2003/03/13	03:37:50	0.000	0.01
2003/03/13	03:37:55	0.000	-0.01
2003/03/13	03:38:00	0.000	0.00
2003/03/13	03:38:05	0.000	-0.02
2003/03/13	03:38:10	0.000	0.01
2003/03/13	03:38:15	0.000	0.00
2003/03/13	03:38:20	0.000	0.00
2003/03/13	03:38:25	0.000	0.02
2003/03/13	03:38:30	0.000	0.03
2003/03/13	03:38:35	0.000	0.01
2003/03/13	03:38:40	0.000	-0.02
2003/03/13	03:38:45	0.000	0.03
2003/03/13	03:38:50	0.000	-0.01
2003/03/13	03:38:55	0.000	0.00
2003/03/13	03:39:00	0.000	0.01
2003/03/13	03:39:05	0.000	-0.01
2003/03/13	03:39:10	0.000	0.01
2003/03/13	03:39:15	0.000	-0.02
2003/03/13	03:39:20	0.000	0.01
2003/03/13	03:39:25	0.000	0.01
2003/03/13	03:39:30	0.000	0.00
2003/03/13	03:39:35	0.000	0.02
2003/03/13	03:39:40	0.000	0.03
2003/03/13	03:39:45	0.000	0.01
2003/03/13	03:39:50	0.000	-0.02
2003/03/13	03:39:55	0.000	0.03
2003/03/13	03:40:00	0.000	0.00
2003/03/13	03:40:05	0.000	-0.01
2003/03/13	03:40:10	0.000	0.02
2003/03/13	03:40:15	0.000	-0.01
2003/03/13	03:40:20	0.000	0.01
2003/03/13	03:40:25	0.000	-0.01
2003/03/13	03:40:30	0.000	0.01
2003/03/13	03:40:35	0.000	0.01
2003/03/13	03:40:40	0.000	-0.01
2003/03/13	03:40:45	0.000	0.02
2003/03/13	03:40:50	0.000	0.02
2003/03/13	03:40:55	0.000	0.01
2003/03/13	03:41:00	0.000	-0.01
2003/03/13	03:41:05	0.000	0.03
2003/03/13	03:41:10	0.000	0.01
2003/03/13	03:41:15	0.000	-0.01
2003/03/13	03:41:20	0.000	0.03
2003/03/13	03:41:25	0.000	-0.02
2003/03/13	03:41:30	0.000	0.00
2003/03/13	03:41:35	0.000	-0.01
2003/03/13	03:41:40	0.000	0.01
2003/03/13	03:41:45	0.000	0.01
2003/03/13	03:41:50	0.000	-0.01
2003/03/13	03:41:55	0.000	0.01
2003/03/13	03:42:00	0.000	0.02
2003/03/13	03:42:05	0.000	0.01
2003/03/13	03:42:10	0.000	-0.01
2003/03/13	03:42:15	0.000	0.03
2003/03/13	03:42:20	0.000	0.02
2003/03/13	03:42:25	0.000	-0.02
2003/03/13	03:42:30	0.000	0.03
2003/03/13	03:42:35	0.000	-0.02
2003/03/13	03:42:40	0.000	0.00
2003/03/13	03:42:45	0.000	0.00
2003/03/13	03:42:50	0.000	0.00
2003/03/13	03:42:55	0.000	0.01
2003/03/13	03:43:00	0.000	-0.01

0.02

2003/03/13 03:35:00

0.01

2003/03/13 03:40:00

2003/03/13	03:43:06	0.000	0.02
2003/03/13	03:43:10	0.000	0.01
2003/03/13	03:43:16	0.000	0.01
2003/03/13	03:43:20	0.000	0.00
2003/03/13	03:43:25	0.000	0.03
2003/03/13	03:43:30	0.000	0.02
2003/03/13	03:43:35	0.000	-0.02
2003/03/13	03:43:40	0.000	0.03
2003/03/13	03:43:45	0.000	-0.01
2003/03/13	03:43:50	0.000	0.00
2003/03/13	03:43:55	0.000	0.00
2003/03/13	03:44:00	0.000	-0.01
2003/03/13	03:44:05	0.000	0.00
2003/03/13	03:44:10	0.000	-0.02
2003/03/13	03:44:15	0.000	0.01
2003/03/13	03:44:20	0.000	0.00
2003/03/13	03:44:25	0.000	0.00
2003/03/13	03:44:30	0.000	0.02
2003/03/13	03:44:35	0.000	0.03
2003/03/13	03:44:40	0.000	0.01
2003/03/13	03:44:45	0.000	-0.02
2003/03/13	03:44:50	0.000	0.03
2003/03/13	03:44:55	0.000	-0.01
2003/03/13	03:45:00	0.000	0.00
2003/03/13	03:45:05	0.000	0.01
2003/03/13	03:45:10	0.000	-0.01
2003/03/13	03:45:15	0.000	0.01
2003/03/13	03:45:20	0.000	-0.02
2003/03/13	03:45:25	0.000	0.01
2003/03/13	03:45:30	0.000	-0.02
2003/03/13	03:45:35	0.000	0.01
2003/03/13	03:45:40	0.000	0.01
2003/03/13	03:45:45	0.000	-0.01
2003/03/13	03:45:50	0.000	0.02
2003/03/13	03:45:55	0.000	0.03
2003/03/13	03:46:00	0.000	0.01
2003/03/13	03:46:05	0.000	-0.02
2003/03/13	03:46:10	0.000	0.03
2003/03/13	03:46:15	0.000	0.00
2003/03/13	03:46:20	0.000	-0.01
2003/03/13	03:46:25	0.000	0.02
2003/03/13	03:46:30	0.000	-0.02
2003/03/13	03:46:35	0.000	0.01
2003/03/13	03:46:40	0.000	0.01
2003/03/13	03:46:45	0.000	-0.01
2003/03/13	03:46:50	0.000	0.02
2003/03/13	03:46:55	0.000	0.03
2003/03/13	03:47:00	0.000	0.01
2003/03/13	03:47:05	0.000	-0.02
2003/03/13	03:47:10	0.000	0.03
2003/03/13	03:47:15	0.000	0.00
2003/03/13	03:47:20	0.000	-0.01
2003/03/13	03:47:25	0.000	0.02
2003/03/13	03:47:30	0.000	-0.02
2003/03/13	03:47:35	0.000	0.00
2003/03/13	03:47:40	0.000	-0.01
2003/03/13	03:47:45	0.000	0.01
2003/03/13	03:47:50	0.000	0.01
2003/03/13	03:47:55	0.000	-0.01
2003/03/13	03:48:00	0.000	0.02
2003/03/13	03:48:05	0.000	0.02
2003/03/13	03:48:10	0.000	0.01
2003/03/13	03:48:15	0.000	-0.01
2003/03/13	03:48:20	0.000	0.03
2003/03/13	03:48:25	0.000	0.02
2003/03/13	03:48:30	0.000	-0.02
2003/03/13	03:48:35	0.000	0.03
2003/03/13	03:48:40	0.000	-0.02
2003/03/13	03:48:45	0.000	0.00
2003/03/13	03:48:50	0.000	0.00
2003/03/13	03:48:55	0.000	0.00
2003/03/13	03:49:00	0.000	0.01
2003/03/13	03:49:05	0.000	-0.01
2003/03/13	03:49:10	0.000	0.02
2003/03/13	03:49:15	0.000	0.01
2003/03/13	03:49:20	0.000	0.01
2003/03/13	03:49:25	0.000	0.00
2003/03/13	03:49:30	0.000	0.03
2003/03/13	03:49:35	0.000	0.02
2003/03/13	03:49:40	0.000	-0.02
2003/03/13	03:49:45	0.000	0.03
2003/03/13	03:49:50	0.000	-0.02
2003/03/13	03:49:55	0.000	0.00
2003/03/13	03:50:00	0.000	0.00
2003/03/13	03:50:05	0.000	0.00
2003/03/13	03:50:10	0.000	0.00
2003/03/13	03:50:15	0.000	-0.02
2003/03/13	03:50:20	0.000	0.01
2003/03/13	03:50:25	0.000	0.00
2003/03/13	03:50:30	0.000	0.01
2003/03/13	03:50:35	0.000	0.01
2003/03/13	03:50:40	0.000	0.03
2003/03/13	03:50:45	0.000	0.01
2003/03/13	03:50:50	0.000	-0.02
2003/03/13	03:50:55	0.000	0.03
2003/03/13	03:51:00	0.000	-0.01
2003/03/13	03:51:05	0.000	0.00
2003/03/13	03:51:10	0.000	0.01
2003/03/13	03:51:15	0.000	-0.01
2003/03/13	03:51:20	0.000	0.02
2003/03/13	03:51:25	0.000	-0.02
2003/03/13	03:51:30	0.000	0.01
2003/03/13	03:51:35	0.000	0.00
2003/03/13	03:51:40	0.000	0.00
2003/03/13	03:51:45	0.000	0.02
2003/03/13	03:51:50	0.000	0.03
2003/03/13	03:51:55	0.000	0.01
2003/03/13	03:52:00	0.000	-0.02
2003/03/13	03:52:05	0.000	0.03
2003/03/13	03:52:10	0.000	-0.01
2003/03/13	03:52:15	0.000	-0.01
2003/03/13	03:52:20	0.000	0.02
2003/03/13	03:52:25	0.000	-0.01
2003/03/13	03:52:30	0.000	0.01
2003/03/13	03:52:35	0.000	-0.02
2003/03/13	03:52:40	0.000	0.01
2003/03/13	03:52:45	0.000	0.01
2003/03/13	03:52:50	0.000	-0.01
2003/03/13	03:52:55	0.000	0.02
2003/03/13	03:53:00	0.000	0.03
2003/03/13	03:53:05	0.000	0.01
2003/03/13	03:53:10	0.000	-0.02
2003/03/13	03:53:15	0.000	0.03
2003/03/13	03:53:20	0.000	0.00
2003/03/13	03:53:25	0.000	-0.01
2003/03/13	03:53:30	0.000	0.02
2003/03/13	03:53:35	0.000	-0.01
2003/03/13	03:53:40	0.000	0.00
2003/03/13	03:53:45	0.000	-0.01
2003/03/13	03:53:50	0.000	0.01
2003/03/13	03:53:55	0.000	0.01
2003/03/13	03:54:00	0.000	-0.01
2003/03/13	03:54:05	0.000	0.01
2003/03/13	03:54:10	0.000	0.02

0.00

03:46:00 17:02:20

0.01

03:50:00 17:02:20

2003/03/13	03:54:16	0.000	0.01
2003/03/13	03:54:20	0.000	-0.01
2003/03/13	03:54:25	0.000	0.03
2003/03/13	03:54:30	0.000	0.02
2003/03/13	03:54:35	0.000	-0.01
2003/03/13	03:54:40	0.000	0.02
2003/03/13	03:54:45	0.000	-0.02
2003/03/13	03:54:50	0.000	0.00
2003/03/13	03:54:55	0.000	-0.01
2003/03/13	03:55:00	0.000	0.00
2003/03/13	03:55:05	0.000	0.01
2003/03/13	03:55:10	0.000	-0.01
2003/03/13	03:55:15	0.000	0.02
2003/03/13	03:55:20	0.000	0.01
2003/03/13	03:55:25	0.000	0.01
2003/03/13	03:55:30	0.000	0.00
2003/03/13	03:55:35	0.000	0.03
2003/03/13	03:55:40	0.000	0.02
2003/03/13	03:55:45	0.000	-0.02
2003/03/13	03:55:50	0.000	0.03
2003/03/13	03:55:55	0.000	-0.02
2003/03/13	03:56:00	0.000	0.01
2003/03/13	03:56:05	0.000	0.00
2003/03/13	03:56:10	0.000	0.00
2003/03/13	03:56:15	0.000	0.00
2003/03/13	03:56:20	0.000	-0.02
2003/03/13	03:56:25	0.000	0.01
2003/03/13	03:56:30	0.000	0.01
2003/03/13	03:56:35	0.000	0.01
2003/03/13	03:56:40	0.000	0.01
2003/03/13	03:56:45	0.000	0.03
2003/03/13	03:56:50	0.000	0.01
2003/03/13	03:56:55	0.000	-0.02
2003/03/13	03:57:00	0.000	0.03
2003/03/13	03:57:05	0.000	-0.01
2003/03/13	03:57:10	0.000	0.00
2003/03/13	03:57:15	0.000	0.01
2003/03/13	03:57:20	0.000	-0.01
2003/03/13	03:57:25	0.000	0.02
2003/03/13	03:57:30	0.000	-0.02
2003/03/13	03:57:35	0.000	0.01
2003/03/13	03:57:40	0.000	0.00
2003/03/13	03:57:45	0.000	0.00
2003/03/13	03:57:50	0.000	0.02
2003/03/13	03:57:55	0.000	0.03
2003/03/13	03:58:00	0.000	0.01
2003/03/13	03:58:05	0.000	-0.02
2003/03/13	03:58:10	0.000	0.03
2003/03/13	03:58:15	0.000	-0.01
2003/03/13	03:58:20	0.000	0.00
2003/03/13	03:58:25	0.000	0.01
2003/03/13	03:58:30	0.000	-0.01
2003/03/13	03:58:35	0.000	0.01
2003/03/13	03:58:40	0.000	-0.02
2003/03/13	03:58:45	0.000	0.01
2003/03/13	03:58:50	0.000	0.01
2003/03/13	03:58:55	0.000	0.00
2003/03/13	03:59:00	0.000	0.01
2003/03/13	03:59:05	0.000	0.03
2003/03/13	03:59:10	0.000	0.02
2003/03/13	03:59:15	0.000	-0.02
2003/03/13	03:59:20	0.000	0.03
2003/03/13	03:59:25	0.000	0.00
2003/03/13	03:59:30	0.000	-0.01
2003/03/13	03:59:35	0.000	0.02
2003/03/13	03:59:40	0.000	-0.01
2003/03/13	03:59:45	0.000	0.00
2003/03/13	03:59:50	0.000	-0.01
2003/03/13	03:59:55	0.000	0.01
2003/03/13	04:00:00	0.000	0.01
2003/03/13	04:00:05	0.000	-0.01
2003/03/13	04:00:10	0.000	0.01
2003/03/13	04:00:15	0.000	0.03
2003/03/13	04:00:20	0.000	0.01
2003/03/13	04:00:25	0.000	-0.01
2003/03/13	04:00:30	0.000	0.04
2003/03/13	04:00:35	0.000	0.01
2003/03/13	04:00:40	0.000	-0.01
2003/03/13	04:00:45	0.000	0.02
2003/03/13	04:00:50	0.000	-0.01
2003/03/13	04:00:55	0.000	0.00
2003/03/13	04:01:00	0.000	-0.01
2003/03/13	04:01:05	0.000	0.01
2003/03/13	04:01:10	0.000	0.02
2003/03/13	04:01:15	0.000	0.00
2003/03/13	04:01:20	0.000	0.03
2003/03/13	04:01:25	0.000	0.02
2003/03/13	04:01:30	0.000	0.02
2003/03/13	04:01:35	0.000	0.00
2003/03/13	04:01:40	0.000	0.05
2003/03/13	04:01:45	0.000	0.03
2003/03/13	04:01:50	0.000	0.00
2003/03/13	04:01:55	0.000	0.04
2003/03/13	04:02:00	0.000	0.00
2003/03/13	04:02:05	0.000	0.02
2003/03/13	04:02:10	0.000	0.02
2003/03/13	04:02:15	0.000	0.02
2003/03/13	04:02:20	0.000	0.03
2003/03/13	04:02:25	0.000	0.02
2003/03/13	04:02:30	0.000	0.05
2003/03/13	04:02:35	0.000	0.04
2003/03/13	04:02:40	0.000	0.04
2003/03/13	04:02:45	0.000	0.04
2003/03/13	04:02:50	0.000	0.07
2003/03/13	04:02:55	0.000	0.06
2003/03/13	04:03:00	0.000	0.03
2003/03/13	04:03:05	0.000	0.08
2003/03/13	04:03:10	0.000	0.03
2003/03/13	04:03:15	0.000	0.05
2003/03/13	04:03:20	0.000	0.06
2003/03/13	04:03:25	0.000	0.04
2003/03/13	04:03:30	0.000	0.07
2003/03/13	04:03:35	0.000	0.04
2003/03/13	04:03:40	0.000	0.08
2003/03/13	04:03:45	0.000	0.08
2003/03/13	04:03:50	0.000	0.07
2003/03/13	04:03:55	0.000	0.08
2003/03/13	04:04:00	0.000	0.09
2003/03/13	04:04:05	0.000	0.07
2003/03/13	04:04:10	0.000	0.05
2003/03/13	04:04:15	0.000	0.10
2003/03/13	04:04:20	0.000	0.06
2003/03/13	04:04:25	0.000	0.07
2003/03/13	04:04:30	0.000	0.08
2003/03/13	04:04:35	0.000	0.07
2003/03/13	04:04:40	0.000	0.10
2003/03/13	04:04:45	0.000	0.07
2003/03/13	04:04:50	0.000	0.09
2003/03/13	04:04:55	0.000	0.09
2003/03/13	04:05:00	0.000	0.08
2003/03/13	04:05:05	0.000	0.10
2003/03/13	04:05:10	0.000	0.11
2003/03/13	04:05:15	0.000	0.10
2003/03/13	04:05:20	0.000	0.08

0.00

03:50:04 [m] [u] [s] [ms]

0.01

03:50:05 [m] [u] [s] [ms]

0.04

03:50:06 [m] [u] [s] [ms]

2003/03/13	04:05:25	0.000	0.10
2003/03/13	04:05:30	0.000	0.04
2003/03/13	04:05:35	0.000	0.01
2003/03/13	04:05:40	0.000	0.03
2003/03/13	04:05:45	0.000	-0.01
2003/03/13	04:05:50	0.000	0.01
2003/03/13	04:05:55	0.000	-0.01
2003/03/13	04:06:00	0.000	0.01
2003/03/13	04:06:05	0.000	0.01
2003/03/13	04:06:10	0.000	-0.01
2003/03/13	04:06:15	0.000	0.01
2003/03/13	04:06:20	0.000	0.02
2003/03/13	04:06:25	0.000	0.02
2003/03/13	04:06:30	0.000	0.02
2003/03/13	04:06:35	0.000	0.03
2003/03/13	04:06:40	0.000	0.08
2003/03/13	04:06:45	0.000	0.07
2003/03/13	04:06:50	0.000	0.11
2003/03/13	04:06:55	0.000	0.07
2003/03/13	04:07:00	0.000	0.09
2003/03/13	04:07:05	0.000	0.07
2003/03/13	04:07:10	0.000	0.07
2003/03/13	04:07:15	0.000	0.05
2003/03/13	04:07:20	0.000	0.01
2003/03/13	04:07:25	0.000	0.03
2003/03/13	04:07:30	0.000	0.02
2003/03/13	04:07:35	0.000	0.01
2003/03/13	04:07:40	0.000	-0.01
2003/03/13	04:07:45	0.000	0.04
2003/03/13	04:07:50	0.000	0.02
2003/03/13	04:07:55	0.000	-0.02
2003/03/13	04:08:00	0.000	0.03
2003/03/13	04:08:05	0.000	-0.02
2003/03/13	04:08:10	0.000	0.01
2003/03/13	04:08:15	0.000	0.00
2003/03/13	04:08:20	0.000	0.00
2003/03/13	04:08:25	0.000	0.01
2003/03/13	04:08:30	0.000	-0.01
2003/03/13	04:08:35	0.000	0.02
2003/03/13	04:08:40	0.000	0.01
2003/03/13	04:08:45	0.000	0.01
2003/03/13	04:08:50	0.000	0.00
2003/03/13	04:08:55	0.000	0.03
2003/03/13	04:09:00	0.000	0.01
2003/03/13	04:09:05	0.000	-0.02
2003/03/13	04:09:10	0.000	0.03
2003/03/13	04:09:15	0.000	-0.02
2003/03/13	04:09:20	0.000	0.00
2003/03/13	04:09:25	0.000	0.00
2003/03/13	04:09:30	0.000	0.00
2003/03/13	04:09:35	0.000	0.02
2003/03/13	04:09:40	0.000	-0.02
2003/03/13	04:09:45	0.000	0.01
2003/03/13	04:09:50	0.000	0.00
2003/03/13	04:09:55	0.000	0.01
2003/03/13	04:10:00	0.000	0.01
2003/03/13	04:10:05	0.000	0.03
2003/03/13	04:10:10	0.000	0.01
2003/03/13	04:10:15	0.000	-0.02
2003/03/13	04:10:20	0.000	0.03
2003/03/13	04:10:25	0.000	-0.01
2003/03/13	04:10:30	0.000	0.00
2003/03/13	04:10:35	0.000	0.01
2003/03/13	04:10:40	0.000	-0.01
2003/03/13	04:10:45	0.000	0.01
2003/03/13	04:10:50	0.000	-0.02
2003/03/13	04:10:55	0.000	0.01
2003/03/13	04:11:00	0.000	0.01
2003/03/13	04:11:05	0.000	0.00
2003/03/13	04:11:10	0.000	0.01
2003/03/13	04:11:15	0.000	0.03
2003/03/13	04:11:20	0.000	0.02
2003/03/13	04:11:25	0.000	-0.02
2003/03/13	04:11:30	0.000	0.03
2003/03/13	04:11:35	0.000	0.00
2003/03/13	04:11:40	0.000	-0.01
2003/03/13	04:11:45	0.000	0.02
2003/03/13	04:11:50	0.000	-0.01
2003/03/13	04:11:55	0.000	0.01
2003/03/13	04:12:00	0.000	-0.01
2003/03/13	04:12:05	0.000	0.01
2003/03/13	04:12:10	0.000	0.01
2003/03/13	04:12:15	0.000	-0.01
2003/03/13	04:12:20	0.000	0.01
2003/03/13	04:12:25	0.000	0.03
2003/03/13	04:12:30	0.000	0.01
2003/03/13	04:12:35	0.000	-0.02
2003/03/13	04:12:40	0.000	0.04
2003/03/13	04:12:45	0.000	0.01
2003/03/13	04:12:50	0.000	-0.01
2003/03/13	04:12:55	0.000	0.02
2003/03/13	04:13:00	0.000	-0.01
2003/03/13	04:13:05	0.000	0.00
2003/03/13	04:13:10	0.000	-0.01
2003/03/13	04:13:15	0.000	0.01
2003/03/13	04:13:20	0.000	0.01
2003/03/13	04:13:25	0.000	-0.01
2003/03/13	04:13:30	0.000	0.02
2003/03/13	04:13:35	0.000	0.02
2003/03/13	04:13:40	0.000	0.01
2003/03/13	04:13:45	0.000	-0.01
2003/03/13	04:13:50	0.000	0.04
2003/03/13	04:13:55	0.000	0.02
2003/03/13	04:14:00	0.000	-0.02
2003/03/13	04:14:05	0.000	0.03
2003/03/13	04:14:10	0.000	-0.02
2003/03/13	04:14:15	0.000	0.01
2003/03/13	04:14:20	0.000	-0.01
2003/03/13	04:14:25	0.000	0.00
2003/03/13	04:14:30	0.000	0.01
2003/03/13	04:14:35	0.000	-0.01
2003/03/13	04:14:40	0.000	0.02
2003/03/13	04:14:45	0.000	0.01
2003/03/13	04:14:50	0.000	0.01
2003/03/13	04:14:55	0.000	0.00
2003/03/13	04:15:00	0.000	0.03
2003/03/13	04:15:05	0.000	0.01
2003/03/13	04:15:10	0.000	-0.02
2003/03/13	04:15:15	0.000	0.03
2003/03/13	04:15:20	0.000	-0.02
2003/03/13	04:15:25	0.000	0.00
2003/03/13	04:15:30	0.000	0.00
2003/03/13	04:15:35	0.000	0.00
2003/03/13	04:15:40	0.000	0.02
2003/03/13	04:15:45	0.000	-0.02
2003/03/13	04:15:50	0.000	0.01
2003/03/13	04:15:55	0.000	0.00
2003/03/13	04:16:00	0.000	0.01
2003/03/13	04:16:05	0.000	0.01
2003/03/13	04:16:10	0.000	0.03
2003/03/13	04:16:15	0.000	0.01
2003/03/13	04:16:20	0.000	-0.02
2003/03/13	04:16:25	0.000	0.03
2003/03/13	04:16:30	0.000	-0.01

0.03

04:09:25 10/10/2003

0.01

04:10:05 10/10/2003

2003/03/13	04:16:36	0.000	0.00
2003/03/13	04:16:40	0.000	0.01
2003/03/13	04:16:46	0.000	-0.01
2003/03/13	04:16:50	0.000	0.01
2003/03/13	04:16:55	0.000	-0.02
2003/03/13	04:17:00	0.000	0.01
2003/03/13	04:17:05	0.000	0.00
2003/03/13	04:17:10	0.000	0.00
2003/03/13	04:17:15	0.000	0.01
2003/03/13	04:17:20	0.000	0.03
2003/03/13	04:17:25	0.000	0.02
2003/03/13	04:17:30	0.000	-0.02
2003/03/13	04:17:35	0.000	0.03
2003/03/13	04:17:40	0.000	-0.01
2003/03/13	04:17:45	0.000	-0.01
2003/03/13	04:17:50	0.000	0.02
2003/03/13	04:17:55	0.000	-0.01
2003/03/13	04:18:00	0.000	0.01
2003/03/13	04:18:05	0.000	-0.02
2003/03/13	04:18:10	0.000	0.01
2003/03/13	04:18:15	0.000	0.01
2003/03/13	04:18:20	0.000	-0.01
2003/03/13	04:18:25	0.000	0.01
2003/03/13	04:18:30	0.000	0.03
2003/03/13	04:18:35	0.000	0.01
2003/03/13	04:18:40	0.000	-0.02
2003/03/13	04:18:45	0.000	0.04
2003/03/13	04:18:50	0.000	0.01
2003/03/13	04:18:55	0.000	-0.01
2003/03/13	04:19:00	0.000	0.02
2003/03/13	04:19:05	0.000	-0.01
2003/03/13	04:19:10	0.000	0.00
2003/03/13	04:19:15	0.000	-0.01
2003/03/13	04:19:20	0.000	0.01
2003/03/13	04:19:25	0.000	0.01
2003/03/13	04:19:30	0.000	-0.01
2003/03/13	04:19:35	0.000	0.02
2003/03/13	04:19:40	0.000	0.02
2003/03/13	04:19:45	0.000	0.01
2003/03/13	04:19:50	0.000	-0.01
2003/03/13	04:19:55	0.000	0.04
2003/03/13	04:20:00	0.000	0.01
2003/03/13	04:20:05	0.000	-0.01
2003/03/13	04:20:10	0.000	0.03
2003/03/13	04:20:15	0.000	-0.02
2003/03/13	04:20:20	0.000	0.01
2003/03/13	04:20:25	0.000	-0.01
2003/03/13	04:20:30	0.000	0.00
2003/03/13	04:20:35	0.000	0.01
2003/03/13	04:20:40	0.000	-0.01
2003/03/13	04:20:45	0.000	0.02
2003/03/13	04:20:50	0.000	0.01
2003/03/13	04:20:55	0.000	0.01
2003/03/13	04:21:00	0.000	0.00
2003/03/13	04:21:05	0.000	0.03
2003/03/13	04:21:10	0.000	0.01
2003/03/13	04:21:15	0.000	-0.02
2003/03/13	04:21:20	0.000	0.03
2003/03/13	04:21:25	0.000	-0.02
2003/03/13	04:21:30	0.000	0.00
2003/03/13	04:21:35	0.000	0.00
2003/03/13	04:21:40	0.000	0.00
2003/03/13	04:21:45	0.000	0.02
2003/03/13	04:21:50	0.000	-0.02
2003/03/13	04:21:55	0.000	0.01
2003/03/13	04:22:00	0.000	0.00
2003/03/13	04:22:05	0.000	0.01
2003/03/13	04:22:10	0.000	0.01
2003/03/13	04:22:15	0.000	0.03
2003/03/13	04:22:20	0.000	0.01
2003/03/13	04:22:25	0.000	-0.02
2003/03/13	04:22:30	0.000	0.03
2003/03/13	04:22:35	0.000	-0.02
2003/03/13	04:22:40	0.000	0.00
2003/03/13	04:22:45	0.000	0.01
2003/03/13	04:22:50	0.000	-0.01
2003/03/13	04:22:55	0.000	0.02
2003/03/13	04:23:00	0.000	-0.02
2003/03/13	04:23:05	0.000	0.01
2003/03/13	04:23:10	0.000	0.00
2003/03/13	04:23:15	0.000	0.00
2003/03/13	04:23:20	0.000	0.01
2003/03/13	04:23:25	0.000	0.03
2003/03/13	04:23:30	0.000	0.02
2003/03/13	04:23:35	0.000	-0.01
2003/03/13	04:23:40	0.000	0.04
2003/03/13	04:23:45	0.000	0.00
2003/03/13	04:23:50	0.000	0.01
2003/03/13	04:23:55	0.000	0.03
2003/03/13	04:24:00	0.000	0.00
2003/03/13	04:24:05	0.000	0.02
2003/03/13	04:24:10	0.000	-0.01
2003/03/13	04:24:15	0.000	0.02
2003/03/13	04:24:20	0.000	0.02
2003/03/13	04:24:25	0.000	0.01
2003/03/13	04:24:30	0.000	0.02
2003/03/13	04:24:35	0.000	0.03
2003/03/13	04:24:40	0.000	0.01
2003/03/13	04:24:45	0.000	-0.02
2003/03/13	04:24:50	0.000	0.03
2003/03/13	04:24:55	0.000	0.00
2003/03/13	04:25:00	0.000	-0.01
2003/03/13	04:25:05	0.000	0.02
2003/03/13	04:25:10	0.000	-0.01
2003/03/13	04:25:15	0.000	0.00
2003/03/13	04:25:20	0.000	-0.01
2003/03/13	04:25:25	0.000	0.01
2003/03/13	04:25:30	0.000	0.01
2003/03/13	04:25:35	0.000	-0.01
2003/03/13	04:25:40	0.000	0.02
2003/03/13	04:25:45	0.000	0.02
2003/03/13	04:25:50	0.000	0.01
2003/03/13	04:25:55	0.000	-0.01
2003/03/13	04:26:00	0.000	0.04
2003/03/13	04:26:05	0.000	0.01
2003/03/13	04:26:10	0.000	-0.01
2003/03/13	04:26:15	0.000	0.03
2003/03/13	04:26:20	0.000	-0.02
2003/03/13	04:26:25	0.000	0.01
2003/03/13	04:26:30	0.000	-0.01
2003/03/13	04:26:35	0.000	0.00
2003/03/13	04:26:40	0.000	0.01
2003/03/13	04:26:45	0.000	-0.01
2003/03/13	04:26:50	0.000	0.02
2003/03/13	04:26:55	0.000	0.01
2003/03/13	04:27:00	0.000	0.01
2003/03/13	04:27:05	0.000	0.00
2003/03/13	04:27:10	0.000	0.03
2003/03/13	04:27:15	0.000	0.01
2003/03/13	04:27:20	0.000	-0.02
2003/03/13	04:27:25	0.000	0.03
2003/03/13	04:27:30	0.000	-0.02
2003/03/13	04:27:35	0.000	0.00
2003/03/13	04:27:40	0.000	0.00

0.01

04:20:05 10/14/2003

0.01

04:20:05 10/14/2003

2003/03/13	04:27:45	0.000	0.00
2003/03/13	04:27:50	0.000	0.02
2003/03/13	04:27:55	0.000	-0.02
2003/03/13	04:28:00	0.000	0.01
2003/03/13	04:28:05	0.000	0.01
2003/03/13	04:28:10	0.000	0.01
2003/03/13	04:28:15	0.000	0.01
2003/03/13	04:28:20	0.000	0.03
2003/03/13	04:28:25	0.000	0.01
2003/03/13	04:28:30	0.000	-0.02
2003/03/13	04:28:35	0.000	0.03
2003/03/13	04:28:40	0.000	-0.02
2003/03/13	04:28:45	0.000	0.00
2003/03/13	04:28:50	0.000	0.02
2003/03/13	04:28:55	0.000	0.02
2003/03/13	04:29:00	0.000	0.05
2003/03/13	04:29:05	0.000	0.03
2003/03/13	04:29:10	0.000	0.07
2003/03/13	04:29:15	0.000	0.07
2003/03/13	04:29:20	0.000	0.07
2003/03/13	04:29:25	0.000	0.09
2003/03/13	04:29:30	0.000	0.11
2003/03/13	04:29:35	0.000	0.11
2003/03/13	04:29:40	0.000	0.09
2003/03/13	04:29:45	0.000	0.15
2003/03/13	04:29:50	0.000	0.12
2003/03/13	04:29:55	0.000	0.13
2003/03/13	04:30:00	0.000	0.15
2003/03/13	04:30:05	0.000	0.14
2003/03/13	04:30:10	0.000	0.15
2003/03/13	04:30:15	0.000	0.14
2003/03/13	04:30:20	0.000	0.17
2003/03/13	04:30:25	0.000	0.17
2003/03/13	04:30:30	0.000	0.16
2003/03/13	04:30:35	0.000	0.18
2003/03/13	04:30:40	0.000	0.21
2003/03/13	04:30:45	0.000	0.20
2003/03/13	04:30:50	0.000	0.17
2003/03/13	04:30:55	0.000	0.23
2003/03/13	04:31:00	0.000	0.25
2003/03/13	04:31:05	0.000	0.19
2003/03/13	04:31:10	0.000	0.22
2003/03/13	04:31:15	0.000	0.19
2003/03/13	04:31:20	0.000	0.21
2003/03/13	04:31:25	0.000	0.19
2003/03/13	04:31:30	0.000	0.22
2003/03/13	04:31:35	0.000	0.22
2003/03/13	04:31:40	0.000	0.21
2003/03/13	04:31:45	0.000	0.24
2003/03/13	04:31:50	0.000	0.24
2003/03/13	04:31:55	0.000	0.22
2003/03/13	04:32:00	0.000	0.20
2003/03/13	04:32:05	0.000	0.25
2003/03/13	04:32:10	0.000	0.23
2003/03/13	04:32:15	0.000	0.20
2003/03/13	04:32:20	0.000	0.24
2003/03/13	04:32:25	0.000	0.20
2003/03/13	04:32:30	0.000	0.22
2003/03/13	04:32:35	0.000	0.21
2003/03/13	04:32:40	0.000	0.21
2003/03/13	04:32:45	0.000	0.21
2003/03/13	04:32:50	0.000	0.20
2003/03/13	04:32:55	0.000	0.22
2003/03/13	04:33:00	0.000	0.22
2003/03/13	04:33:05	0.000	0.21
2003/03/13	04:33:10	0.000	0.20
2003/03/13	04:33:15	0.000	0.23
2003/03/13	04:33:20	0.000	0.21
2003/03/13	04:33:25	0.000	0.16
2003/03/13	04:33:30	0.000	0.22
2003/03/13	04:33:35	0.000	0.17
2003/03/13	04:33:40	0.000	0.19
2003/03/13	04:33:45	0.000	0.16
2003/03/13	04:33:50	0.000	0.17
2003/03/13	04:33:55	0.000	0.19
2003/03/13	04:34:00	0.000	0.15
2003/03/13	04:34:05	0.000	0.17
2003/03/13	04:34:10	0.000	0.17
2003/03/13	04:34:15	0.000	0.17
2003/03/13	04:34:20	0.000	0.16
2003/03/13	04:34:25	0.000	0.19
2003/03/13	04:34:30	0.000	0.17
2003/03/13	04:34:35	0.000	0.14
2003/03/13	04:34:40	0.000	0.19
2003/03/13	04:34:45	0.000	0.15
2003/03/13	04:34:50	0.000	0.16
2003/03/13	04:34:55	0.000	0.16
2003/03/13	04:35:00	0.000	0.16
2003/03/13	04:35:05	0.000	0.17
2003/03/13	04:35:10	0.000	0.14
2003/03/13	04:35:15	0.000	0.16
2003/03/13	04:35:20	0.000	0.16
2003/03/13	04:35:25	0.000	0.16
2003/03/13	04:35:30	0.000	0.17
2003/03/13	04:35:35	0.000	0.16
2003/03/13	04:35:40	0.000	0.17
2003/03/13	04:35:45	0.000	0.13
2003/03/13	04:35:50	0.000	0.16
2003/03/13	04:35:55	0.000	0.13
2003/03/13	04:36:00	0.000	0.14
2003/03/13	04:36:05	0.000	0.15
2003/03/13	04:36:10	0.000	0.13
2003/03/13	04:36:15	0.000	0.14
2003/03/13	04:36:20	0.000	0.11
2003/03/13	04:36:25	0.000	0.14
2003/03/13	04:36:30	0.000	0.13
2003/03/13	04:36:35	0.000	0.11
2003/03/13	04:36:40	0.000	0.13
2003/03/13	04:36:45	0.000	0.15
2003/03/13	04:36:50	0.000	0.13
2003/03/13	04:36:55	0.000	0.09
2003/03/13	04:37:00	0.000	0.15
2003/03/13	04:37:05	0.000	0.11
2003/03/13	04:37:10	0.000	0.09
2003/03/13	04:37:15	0.000	0.12
2003/03/13	04:37:20	0.000	0.08
2003/03/13	04:37:25	0.000	0.09
2003/03/13	04:37:30	0.000	0.08
2003/03/13	04:37:35	0.000	0.10
2003/03/13	04:37:40	0.000	0.10
2003/03/13	04:37:45	0.000	0.06
2003/03/13	04:37:50	0.000	0.11
2003/03/13	04:37:55	0.000	0.11
2003/03/13	04:38:00	0.000	0.09
2003/03/13	04:38:05	0.000	0.07
2003/03/13	04:38:10	0.000	0.12
2003/03/13	04:38:15	0.000	0.09
2003/03/13	04:38:20	0.000	0.06
2003/03/13	04:38:25	0.000	0.10
2003/03/13	04:38:30	0.000	0.06
2003/03/13	04:38:35	0.000	0.06
2003/03/13	04:38:40	0.000	0.06
2003/03/13	04:38:45	0.000	0.06
2003/03/13	04:38:50	0.000	0.06

0.02

2003/03/13 04:30:00

0.19

2003/03/13 04:34:00

2003/03/13 04:38:55 0.000 0.06
2003/03/13 04:39:00 0.000 0.09
2003/03/13 04:39:05 0.000 0.09
2003/03/13 04:39:10 0.000 0.09
2003/03/13 04:39:15 0.000 0.07
2003/03/13 04:39:20 0.000 0.11
2003/03/13 04:39:25 0.000 0.08
2003/03/13 04:39:30 0.000 0.09
2003/03/13 04:39:35 0.000 0.11
2003/03/13 04:39:40 0.000 0.09
2003/03/13 04:39:45 0.000 0.09
2003/03/13 04:39:50 0.000 0.08
2003/03/13 04:39:55 0.000 0.09
2003/03/13 04:40:00 0.000 0.12
2003/03/13 04:40:05 0.000 0.09
2003/03/13 04:40:10 0.000 0.13
2003/03/13 04:40:15 0.000 0.13
2003/03/13 04:40:20 0.000 0.14
2003/03/13 04:40:25 0.000 0.14
2003/03/13 04:40:30 0.000 0.17
2003/03/13 04:40:35 0.000 0.15
2003/03/13 04:40:40 0.000 0.13
2003/03/13 04:40:45 0.000 0.19
2003/03/13 04:40:50 0.000 0.14
2003/03/13 04:40:55 0.000 0.16
2003/03/13 04:41:00 0.000 0.17
2003/03/13 04:41:05 0.000 0.16
2003/03/13 04:41:10 0.000 0.19
2003/03/13 04:41:15 0.000 0.17
2003/03/13 04:41:20 0.000 0.20
2003/03/13 04:41:25 0.000 0.20
2003/03/13 04:41:30 0.000 0.20
2003/03/13 04:41:35 0.000 0.21
2003/03/13 04:41:40 0.000 0.23
2003/03/13 04:41:45 0.000 0.23
2003/03/13 04:41:50 0.000 0.17
2003/03/13 04:41:55 0.000 0.18
2003/03/13 04:42:00 0.000 0.09
2003/03/13 04:42:05 0.000 0.08
2003/03/13 04:42:10 0.000 0.06
2003/03/13 04:42:15 0.000 0.01
2003/03/13 04:42:20 0.000 0.01
2003/03/13 04:42:25 0.000 -0.02
2003/03/13 04:42:30 0.000 0.01
2003/03/13 04:42:35 0.000 0.01
2003/03/13 04:42:40 0.000 0.00
2003/03/13 04:42:45 0.000 0.01
2003/03/13 04:42:50 0.000 0.04
2003/03/13 04:42:55 0.000 0.09
2003/03/13 04:43:00 0.000 0.10
2003/03/13 04:43:05 0.000 0.20
2003/03/13 04:43:10 0.000 0.19
2003/03/13 04:43:15 0.000 0.20
2003/03/13 04:43:20 0.000 0.24
2003/03/13 04:43:25 0.000 0.22
2003/03/13 04:43:30 0.000 0.24
2003/03/13 04:43:35 0.000 0.19
2003/03/13 04:43:40 0.000 0.16
2003/03/13 04:43:45 0.000 0.12
2003/03/13 04:43:50 0.000 0.06
2003/03/13 04:43:55 0.000 0.07
2003/03/13 04:44:00 0.000 0.05
2003/03/13 04:44:05 0.000 0.01
2003/03/13 04:44:10 0.000 -0.01
2003/03/13 04:44:15 0.000 0.04
2003/03/13 04:44:20 0.000 0.01
2003/03/13 04:44:25 0.000 -0.01
2003/03/13 04:44:30 0.000 0.02
2003/03/13 04:44:35 0.000 -0.01
2003/03/13 04:44:40 0.000 0.01
2003/03/13 04:44:45 0.000 -0.01
2003/03/13 04:44:50 0.000 0.01
2003/03/13 04:44:55 0.000 0.01
2003/03/13 04:45:00 0.000 -0.01
2003/03/13 04:45:05 0.000 0.02
2003/03/13 04:45:10 0.000 0.01
2003/03/13 04:45:15 0.000 0.01
2003/03/13 04:45:20 0.000 -0.01
2003/03/13 04:45:25 0.000 0.03
2003/03/13 04:45:30 0.000 0.01
2003/03/13 04:45:35 0.000 -0.02
2003/03/13 04:45:40 0.000 0.03
2003/03/13 04:45:45 0.000 -0.02
2003/03/13 04:45:50 0.000 0.00
2003/03/13 04:45:55 0.000 0.00
2003/03/13 04:46:00 0.000 0.00
2003/03/13 04:46:05 0.000 0.02
2003/03/13 04:46:10 0.000 -0.02
2003/03/13 04:46:15 0.000 0.01
2003/03/13 04:46:20 0.000 0.01
2003/03/13 04:46:25 0.000 0.01
2003/03/13 04:46:30 0.000 0.00
2003/03/13 04:46:35 0.000 0.03
2003/03/13 04:46:40 0.000 0.01
2003/03/13 04:46:45 0.000 -0.01
2003/03/13 04:46:50 0.000 0.04
2003/03/13 04:46:55 0.000 -0.01
2003/03/13 04:47:00 0.000 0.02
2003/03/13 04:47:05 0.000 0.04
2003/03/13 04:47:10 0.000 0.03
2003/03/13 04:47:15 0.000 0.06
2003/03/13 04:47:20 0.000 0.03
2003/03/13 04:47:25 0.000 0.08
2003/03/13 04:47:30 0.000 0.07
2003/03/13 04:47:35 0.000 0.07
2003/03/13 04:47:40 0.000 0.08
2003/03/13 04:47:45 0.000 0.10
2003/03/13 04:47:50 0.000 0.09
2003/03/13 04:47:55 0.000 0.08
2003/03/13 04:48:00 0.000 0.11
2003/03/13 04:48:05 0.000 0.08
2003/03/13 04:48:10 0.000 0.09
2003/03/13 04:48:15 0.000 0.10
2003/03/13 04:48:20 0.000 0.08
2003/03/13 04:48:25 0.000 0.10
2003/03/13 04:48:30 0.000 0.08
2003/03/13 04:48:35 0.000 0.11
2003/03/13 04:48:40 0.000 0.11
2003/03/13 04:48:45 0.000 0.10
2003/03/13 04:48:50 0.000 0.11
2003/03/13 04:48:55 0.000 0.13
2003/03/13 04:49:00 0.000 0.12
2003/03/13 04:49:05 0.000 0.09
2003/03/13 04:49:10 0.000 0.14
2003/03/13 04:49:15 0.000 0.11
2003/03/13 04:49:20 0.000 0.10
2003/03/13 04:49:25 0.000 0.13
2003/03/13 04:49:30 0.000 0.10
2003/03/13 04:49:35 0.000 0.12
2003/03/13 04:49:40 0.000 0.10
2003/03/13 04:49:45 0.000 0.12
2003/03/13 04:49:50 0.000 0.12
2003/03/13 04:49:55 0.000 0.11
2003/03/13 04:50:00 0.000 0.13

0.11

04:38:55-04:50:00

0.11

04:40:00-04:50:00

0.08

04:50:00-04:55:00

2003/03/13	04:50:06	0.000	0.14
2003/03/13	04:50:10	0.000	0.12
2003/03/13	04:50:15	0.000	0.10
2003/03/13	04:50:20	0.000	0.16
2003/03/13	04:50:25	0.000	0.12
2003/03/13	04:50:30	0.000	0.10
2003/03/13	04:50:35	0.000	0.14
2003/03/13	04:50:40	0.000	0.10
2003/03/13	04:50:45	0.000	0.12
2003/03/13	04:50:50	0.000	0.10
2003/03/13	04:50:55	0.000	0.12
2003/03/13	04:51:00	0.000	0.13
2003/03/13	04:51:05	0.000	0.11
2003/03/13	04:51:10	0.000	0.14
2003/03/13	04:51:15	0.000	0.14
2003/03/13	04:51:20	0.000	0.13
2003/03/13	04:51:25	0.000	0.12
2003/03/13	04:51:30	0.000	0.15
2003/03/13	04:51:35	0.000	0.14
2003/03/13	04:51:40	0.000	0.10
2003/03/13	04:51:45	0.000	0.16
2003/03/13	04:51:50	0.000	0.11
2003/03/13	04:51:55	0.000	0.13
2003/03/13	04:52:00	0.000	0.12
2003/03/13	04:52:05	0.000	0.13
2003/03/13	04:52:10	0.000	0.15
2003/03/13	04:52:15	0.000	0.11
2003/03/13	04:52:20	0.000	0.14
2003/03/13	04:52:25	0.000	0.14
2003/03/13	04:52:30	0.000	0.13
2003/03/13	04:52:35	0.000	0.12
2003/03/13	04:52:40	0.000	0.15
2003/03/13	04:52:45	0.000	0.13
2003/03/13	04:52:50	0.000	0.10
2003/03/13	04:52:55	0.000	0.15
2003/03/13	04:53:00	0.000	0.10
2003/03/13	04:53:05	0.000	0.12
2003/03/13	04:53:10	0.000	0.13
2003/03/13	04:53:15	0.000	0.12
2003/03/13	04:53:20	0.000	0.13
2003/03/13	04:53:25	0.000	0.10
2003/03/13	04:53:30	0.000	0.13
2003/03/13	04:53:35	0.000	0.12
2003/03/13	04:53:40	0.000	0.12
2003/03/13	04:53:45	0.000	0.13
2003/03/13	04:53:50	0.000	0.14
2003/03/13	04:53:55	0.000	0.13
2003/03/13	04:54:00	0.000	0.09
2003/03/13	04:54:05	0.000	0.14
2003/03/13	04:54:10	0.000	0.10
2003/03/13	04:54:15	0.000	0.11
2003/03/13	04:54:20	0.000	0.12
2003/03/13	04:54:25	0.000	0.10
2003/03/13	04:54:30	0.000	0.11
2003/03/13	04:54:35	0.000	0.09
2003/03/13	04:54:40	0.000	0.12
2003/03/13	04:54:45	0.000	0.11
2003/03/13	04:54:50	0.000	0.10
2003/03/13	04:54:55	0.000	0.10
2003/03/13	04:55:00	0.000	0.12
2003/03/13	04:55:05	0.000	0.11
2003/03/13	04:55:10	0.000	0.07
2003/03/13	04:55:15	0.000	0.13
2003/03/13	04:55:20	0.000	0.09
2003/03/13	04:55:25	0.000	0.08
2003/03/13	04:55:30	0.000	0.10
2003/03/13	04:55:35	0.000	0.08
2003/03/13	04:55:40	0.000	0.09
2003/03/13	04:55:45	0.000	0.07
2003/03/13	04:55:50	0.000	0.10
2003/03/13	04:55:55	0.000	0.10
2003/03/13	04:56:00	0.000	0.08
2003/03/13	04:56:05	0.000	0.11
2003/03/13	04:56:10	0.000	0.11
2003/03/13	04:56:15	0.000	0.08
2003/03/13	04:56:20	0.000	0.05
2003/03/13	04:56:25	0.000	0.10
2003/03/13	04:56:30	0.000	0.06
2003/03/13	04:56:35	0.000	0.03
2003/03/13	04:56:40	0.000	0.07
2003/03/13	04:56:45	0.000	0.02
2003/03/13	04:56:50	0.000	0.04
2003/03/13	04:56:55	0.000	0.01
2003/03/13	04:57:00	0.000	0.02
2003/03/13	04:57:05	0.000	0.02
2003/03/13	04:57:10	0.000	0.00
2003/03/13	04:57:15	0.000	0.03
2003/03/13	04:57:20	0.000	0.03
2003/03/13	04:57:25	0.000	0.02
2003/03/13	04:57:30	0.000	0.00
2003/03/13	04:57:35	0.000	0.04
2003/03/13	04:57:40	0.000	0.02
2003/03/13	04:57:45	0.000	0.00
2003/03/13	04:57:50	0.000	0.04
2003/03/13	04:57:55	0.000	-0.01
2003/03/13	04:58:00	0.000	0.02
2003/03/13	04:58:05	0.000	0.01
2003/03/13	04:58:10	0.000	0.01
2003/03/13	04:58:15	0.000	0.03
2003/03/13	04:58:20	0.000	0.00
2003/03/13	04:58:25	0.000	0.03
2003/03/13	04:58:30	0.000	0.04
2003/03/13	04:58:35	0.000	0.06
2003/03/13	04:58:40	0.000	0.03
2003/03/13	04:58:45	0.000	0.07
2003/03/13	04:58:50	0.000	0.05
2003/03/13	04:58:55	0.000	0.03
2003/03/13	04:59:00	0.000	0.07
2003/03/13	04:59:05	0.000	0.03
2003/03/13	04:59:10	0.000	0.05
2003/03/13	04:59:15	0.000	0.08
2003/03/13	04:59:20	0.000	0.05
2003/03/13	04:59:25	0.000	0.08
2003/03/13	04:59:30	0.000	0.05
2003/03/13	04:59:35	0.000	0.08
2003/03/13	04:59:40	0.000	0.08
2003/03/13	04:59:45	0.000	0.08
2003/03/13	04:59:50	0.000	0.09
2003/03/13	04:59:55	0.000	0.12
2003/03/13	05:00:00	0.000	0.11
2003/03/13	05:00:05	0.000	0.07
2003/03/13	05:00:10	0.000	0.13
2003/03/13	05:00:15	0.000	0.09
2003/03/13	05:00:20	0.000	0.11
2003/03/13	05:00:25	0.000	0.12
2003/03/13	05:00:30	0.000	0.11
2003/03/13	05:00:35	0.000	0.13
2003/03/13	05:00:40	0.000	0.11
2003/03/13	05:00:45	0.000	0.14
2003/03/13	05:00:50	0.000	0.14
2003/03/13	05:00:55	0.000	0.12
2003/03/13	05:01:00	0.000	0.10
2003/03/13	05:01:05	0.000	0.09
2003/03/13	05:01:10	0.000	0.08

0.12

RESERVED FOR USE

0.06

RESERVED FOR USE

2003/03/13	05:01:18	0.000	0.00
2003/03/13	05:01:20	0.000	0.04
2003/03/13	05:01:25	0.000	0.00
2003/03/13	05:01:30	0.000	-0.01
2003/03/13	05:01:35	0.000	0.02
2003/03/13	05:01:40	0.000	-0.01
2003/03/13	05:01:45	0.000	0.01
2003/03/13	05:01:50	0.000	0.02
2003/03/13	05:01:55	0.000	0.08
2003/03/13	05:02:00	0.000	0.05
2003/03/13	05:02:05	0.000	0.03
2003/03/13	05:02:10	0.000	0.05
2003/03/13	05:02:15	0.000	0.05
2003/03/13	05:02:20	0.000	0.02
2003/03/13	05:02:25	0.000	-0.01
2003/03/13	05:02:30	0.000	0.05
2003/03/13	05:02:35	0.000	0.02
2003/03/13	05:02:40	0.000	0.00
2003/03/13	05:02:45	0.000	0.02
2003/03/13	05:02:50	0.000	-0.01
2003/03/13	05:02:55	0.000	0.01
2003/03/13	05:03:00	0.000	-0.01
2003/03/13	05:03:05	0.000	0.01
2003/03/13	05:03:10	0.000	0.01
2003/03/13	05:03:15	0.000	-0.01
2003/03/13	05:03:20	0.000	0.02
2003/03/13	05:03:25	0.000	0.02
2003/03/13	05:03:30	0.000	0.01
2003/03/13	05:03:35	0.000	-0.01
2003/03/13	05:03:40	0.000	0.03
2003/03/13	05:03:45	0.000	0.02
2003/03/13	05:03:50	0.000	0.00
2003/03/13	05:03:55	0.000	0.08
2003/03/13	05:04:00	0.000	0.02
2003/03/13	05:04:05	0.000	0.08
2003/03/13	05:04:10	0.000	0.08
2003/03/13	05:04:15	0.000	0.07
2003/03/13	05:04:20	0.000	0.09
2003/03/13	05:04:25	0.000	0.08
2003/03/13	05:04:30	0.000	0.08
2003/03/13	05:04:35	0.000	0.09
2003/03/13	05:04:40	0.000	0.08
2003/03/13	05:04:45	0.000	0.07
2003/03/13	05:04:50	0.000	0.11
2003/03/13	05:04:55	0.000	0.08
2003/03/13	05:05:00	0.000	0.05
2003/03/13	05:05:05	0.000	0.10
2003/03/13	05:05:10	0.000	0.05
2003/03/13	05:05:15	0.000	0.07
2003/03/13	05:05:20	0.000	0.07
2003/03/13	05:05:25	0.000	0.07
2003/03/13	05:05:30	0.000	0.09
2003/03/13	05:05:35	0.000	0.05
2003/03/13	05:05:40	0.000	0.08
2003/03/13	05:05:45	0.000	0.07
2003/03/13	05:05:50	0.000	0.07
2003/03/13	05:05:55	0.000	0.07
2003/03/13	05:06:00	0.000	0.09
2003/03/13	05:06:05	0.000	0.09
2003/03/13	05:06:10	0.000	0.04
2003/03/13	05:06:15	0.000	0.09
2003/03/13	05:06:20	0.000	0.08
2003/03/13	05:06:25	0.000	0.07
2003/03/13	05:06:30	0.000	0.08
2003/03/13	05:06:35	0.000	0.08
2003/03/13	05:06:40	0.000	0.07
2003/03/13	05:06:45	0.000	0.05
2003/03/13	05:06:50	0.000	0.09
2003/03/13	05:06:55	0.000	0.08
2003/03/13	05:07:00	0.000	0.08
2003/03/13	05:07:05	0.000	0.09
2003/03/13	05:07:10	0.000	0.12
2003/03/13	05:07:15	0.000	0.10
2003/03/13	05:07:20	0.000	0.07
2003/03/13	05:07:25	0.000	0.14
2003/03/13	05:07:30	0.000	0.11
2003/03/13	05:07:35	0.000	0.11
2003/03/13	05:07:40	0.000	0.14
2003/03/13	05:07:45	0.000	0.11
2003/03/13	05:07:50	0.000	0.13
2003/03/13	05:07:55	0.000	0.12
2003/03/13	05:08:00	0.000	0.15
2003/03/13	05:08:05	0.000	0.18
2003/03/13	05:08:10	0.000	0.15
2003/03/13	05:08:15	0.000	0.18
2003/03/13	05:08:20	0.000	0.19
2003/03/13	05:08:25	0.000	0.17
2003/03/13	05:08:30	0.000	0.15
2003/03/13	05:08:35	0.000	0.20
2003/03/13	05:08:40	0.000	0.16
2003/03/13	05:08:45	0.000	0.15
2003/03/13	05:08:50	0.000	0.19
2003/03/13	05:08:55	0.000	0.15
2003/03/13	05:09:00	0.000	0.17
2003/03/13	05:09:05	0.000	0.16
2003/03/13	05:09:10	0.000	0.18
2003/03/13	05:09:15	0.000	0.18
2003/03/13	05:09:20	0.000	0.18
2003/03/13	05:09:25	0.000	0.20
2003/03/13	05:09:30	0.000	0.21
2003/03/13	05:09:35	0.000	0.19
2003/03/13	05:09:40	0.000	0.18
2003/03/13	05:09:45	0.000	0.23
2003/03/13	05:09:50	0.000	0.21
2003/03/13	05:09:55	0.000	0.18
2003/03/13	05:10:00	0.000	0.22
2003/03/13	05:10:05	0.000	0.17
2003/03/13	05:10:10	0.000	0.20
2003/03/13	05:10:15	0.000	0.19
2003/03/13	05:10:20	0.000	0.20
2003/03/13	05:10:25	0.000	0.21
2003/03/13	05:10:30	0.000	0.18
2003/03/13	05:10:35	0.000	0.21
2003/03/13	05:10:40	0.000	0.21
2003/03/13	05:10:45	0.000	0.21
2003/03/13	05:10:50	0.000	0.19
2003/03/13	05:10:55	0.000	0.23
2003/03/13	05:11:00	0.000	0.21
2003/03/13	05:11:05	0.000	0.18
2003/03/13	05:11:10	0.000	0.23
2003/03/13	05:11:15	0.000	0.18
2003/03/13	05:11:20	0.000	0.20
2003/03/13	05:11:25	0.000	0.20
2003/03/13	05:11:30	0.000	0.19
2003/03/13	05:11:35	0.000	0.22
2003/03/13	05:11:40	0.000	0.18
2003/03/13	05:11:45	0.000	0.21
2003/03/13	05:11:50	0.000	0.21
2003/03/13	05:11:55	0.000	0.21
2003/03/13	05:12:00	0.000	0.21
2003/03/13	05:12:05	0.000	0.23
2003/03/13	05:12:10	0.000	0.22
2003/03/13	05:12:15	0.000	0.18
2003/03/13	05:12:20	0.000	0.23

0.05

05:04:47 00:00:00

0.12

05:09:57 00:00:00

2003/03/13	05:12:28	0.000	0.20
2003/03/13	05:12:30	0.000	0.21
2003/03/13	05:12:35	0.000	0.22
2003/03/13	05:12:40	0.000	0.20
2003/03/13	05:12:45	0.000	0.22
2003/03/13	05:12:50	0.000	0.20
2003/03/13	05:12:55	0.000	0.24
2003/03/13	05:13:00	0.000	0.23
2003/03/13	05:13:05	0.000	0.23
2003/03/13	05:13:10	0.000	0.24
2003/03/13	05:13:15	0.000	0.27
2003/03/13	05:13:20	0.000	0.26
2003/03/13	05:13:25	0.000	0.22
2003/03/13	05:13:30	0.000	0.28
2003/03/13	05:13:35	0.000	0.24
2003/03/13	05:13:40	0.000	0.24
2003/03/13	05:13:45	0.000	0.27
2003/03/13	05:13:50	0.000	0.24
2003/03/13	05:13:55	0.000	0.26
2003/03/13	05:14:00	0.000	0.25
2003/03/13	05:14:05	0.000	0.28
2003/03/13	05:14:10	0.000	0.28
2003/03/13	05:14:15	0.000	0.27
2003/03/13	05:14:20	0.000	0.30
2003/03/13	05:14:25	0.000	0.30
2003/03/13	05:14:30	0.000	0.29
2003/03/13	05:14:35	0.000	0.28
2003/03/13	05:14:40	0.000	0.31
2003/03/13	05:14:45	0.000	0.29
2003/03/13	05:14:50	0.000	0.28
2003/03/13	05:14:55	0.000	0.31
2003/03/13	05:15:00	0.000	0.28
2003/03/13	05:15:05	0.000	0.30
2003/03/13	05:15:10	0.000	0.29
2003/03/13	05:15:15	0.000	0.31
2003/03/13	05:15:20	0.000	0.31
2003/03/13	05:15:25	0.000	0.29
2003/03/13	05:15:30	0.000	0.33
2003/03/13	05:15:35	0.000	0.33
2003/03/13	05:15:40	0.000	0.31
2003/03/13	05:15:45	0.000	0.33
2003/03/13	05:15:50	0.000	0.34
2003/03/13	05:15:55	0.000	0.32
2003/03/13	05:16:00	0.000	0.28
2003/03/13	05:16:05	0.000	0.34
2003/03/13	05:16:10	0.000	0.29
2003/03/13	05:16:15	0.000	0.31
2003/03/13	05:16:20	0.000	0.30
2003/03/13	05:16:25	0.000	0.30
2003/03/13	05:16:30	0.000	0.32
2003/03/13	05:16:35	0.000	0.28
2003/03/13	05:16:40	0.000	0.31
2003/03/13	05:16:45	0.000	0.31
2003/03/13	05:16:50	0.000	0.29
2003/03/13	05:16:55	0.000	0.28
2003/03/13	05:17:00	0.000	0.32
2003/03/13	05:17:05	0.000	0.29
2003/03/13	05:17:10	0.000	0.28
2003/03/13	05:17:15	0.000	0.30
2003/03/13	05:17:20	0.000	0.28
2003/03/13	05:17:25	0.000	0.28
2003/03/13	05:17:30	0.000	0.28
2003/03/13	05:17:35	0.000	0.27
2003/03/13	05:17:40	0.000	0.29
2003/03/13	05:17:45	0.000	0.28
2003/03/13	05:17:50	0.000	0.28
2003/03/13	05:17:55	0.000	0.27
2003/03/13	05:18:00	0.000	0.27
2003/03/13	05:18:05	0.000	0.27
2003/03/13	05:18:10	0.000	0.29
2003/03/13	05:18:15	0.000	0.27
2003/03/13	05:18:20	0.000	0.19
2003/03/13	05:18:25	0.000	0.19
2003/03/13	05:18:30	0.000	0.10
2003/03/13	05:18:35	0.000	0.07
2003/03/13	05:18:40	0.000	0.05
2003/03/13	05:18:45	0.000	0.01
2003/03/13	05:18:50	0.000	0.02
2003/03/13	05:18:55	0.000	-0.02
2003/03/13	05:19:00	0.000	0.01
2003/03/13	05:19:05	0.000	0.00
2003/03/13	05:19:10	0.000	0.00
2003/03/13	05:19:15	0.000	0.01
2003/03/13	05:19:20	0.000	0.08
2003/03/13	05:19:25	0.000	0.12
2003/03/13	05:19:30	0.000	0.13
2003/03/13	05:19:35	0.000	0.21
2003/03/13	05:19:40	0.000	0.20
2003/03/13	05:19:45	0.000	0.20
2003/03/13	05:19:50	0.000	0.24
2003/03/13	05:19:55	0.000	0.21
2003/03/13	05:20:00	0.000	0.21
2003/03/13	05:20:05	0.000	0.18
2003/03/13	05:20:10	0.000	0.14
2003/03/13	05:20:15	0.000	0.09
2003/03/13	05:20:20	0.000	0.05
2003/03/13	05:20:25	0.000	0.05
2003/03/13	05:20:30	0.000	0.04
2003/03/13	05:20:35	0.000	0.01
2003/03/13	05:20:40	0.000	-0.02
2003/03/13	05:20:45	0.000	0.04
2003/03/13	05:20:50	0.000	0.01
2003/03/13	05:20:55	0.000	-0.01
2003/03/13	05:21:00	0.000	0.02
2003/03/13	05:21:05	0.000	-0.01
2003/03/13	05:21:10	0.000	0.01
2003/03/13	05:21:15	0.000	-0.01
2003/03/13	05:21:20	0.000	0.01
2003/03/13	05:21:25	0.000	0.01
2003/03/13	05:21:30	0.000	-0.01
2003/03/13	05:21:35	0.000	0.02
2003/03/13	05:21:40	0.000	0.02
2003/03/13	05:21:45	0.000	0.01
2003/03/13	05:21:50	0.000	-0.01
2003/03/13	05:21:55	0.000	0.03
2003/03/13	05:22:00	0.000	0.01
2003/03/13	05:22:05	0.000	-0.01
2003/03/13	05:22:10	0.000	0.03
2003/03/13	05:22:15	0.000	-0.02
2003/03/13	05:22:20	0.000	0.01
2003/03/13	05:22:25	0.000	-0.01
2003/03/13	05:22:30	0.000	0.00
2003/03/13	05:22:35	0.000	0.02
2003/03/13	05:22:40	0.000	-0.01
2003/03/13	05:22:45	0.000	0.01
2003/03/13	05:22:50	0.002	0.01
2003/03/13	05:22:55	0.000	0.02
2003/03/13	05:23:00	0.000	0.01
2003/03/13	05:23:05	0.000	0.05
2003/03/13	05:23:10	0.000	0.04
2003/03/13	05:23:15	0.000	0.02
2003/03/13	05:23:20	0.000	0.07
2003/03/13	05:23:25	0.000	0.03
2003/03/13	05:23:30	0.000	0.08

0.23

05/21/2013 11:05:00 AM

0.23

05/22/2013 11:05:00 AM

2003/03/13	05:23:35	0.000	0.07
2003/03/13	05:23:40	0.000	0.06
2003/03/13	05:23:45	0.000	0.06
2003/03/13	05:23:50	0.000	0.06
2003/03/13	05:23:55	0.000	0.09
2003/03/13	05:24:00	0.000	0.10
2003/03/13	05:24:05	0.000	0.09
2003/03/13	05:24:10	0.000	0.10
2003/03/13	05:24:15	0.000	0.12
2003/03/13	05:24:20	0.000	0.11
2003/03/13	05:24:25	0.000	0.08
2003/03/13	05:24:30	0.000	0.14
2003/03/13	05:24:35	0.000	0.10
2003/03/13	05:24:40	0.000	0.11
2003/03/13	05:24:45	0.000	0.12
2003/03/13	05:24:50	0.000	0.10
2003/03/13	05:24:55	0.000	0.12
2003/03/13	05:25:00	0.000	0.10
2003/03/13	05:25:05	0.000	0.13
2003/03/13	05:25:10	0.000	0.13
2003/03/13	05:25:15	0.000	0.12
2003/03/13	05:25:20	0.000	0.13
2003/03/13	05:25:25	0.000	0.15
2003/03/13	05:25:30	0.000	0.14
2003/03/13	05:25:35	0.000	0.11
2003/03/13	05:25:40	0.000	0.18
2003/03/13	05:25:45	0.000	0.13
2003/03/13	05:25:50	0.000	0.12
2003/03/18	05:25:55	0.000	0.14
2003/03/13	05:26:00	0.000	0.12
2003/03/13	05:26:05	0.000	0.13
2003/03/13	05:26:10	0.000	0.12
2003/03/13	05:26:15	0.000	0.14
2003/03/13	05:26:20	0.000	0.14
2003/03/13	05:26:25	0.000	0.13
2003/03/13	05:26:30	0.000	0.18
2003/03/13	05:26:35	0.000	0.19
2003/03/13	05:26:40	0.000	0.14
2003/03/13	05:26:45	0.000	0.12
2003/03/13	05:26:50	0.000	0.17
2003/03/13	05:26:55	0.000	0.14
2003/03/13	05:27:00	0.000	0.13
2003/03/13	05:27:05	0.000	0.18
2003/03/13	05:27:10	0.000	0.13
2003/03/13	05:27:15	0.000	0.15
2003/03/13	05:27:20	0.000	0.13
2003/03/13	05:27:25	0.000	0.15
2003/03/13	05:27:30	0.000	0.15
2003/03/13	05:27:35	0.000	0.13
2003/03/13	05:27:40	0.000	0.18
2003/03/13	05:27:45	0.000	0.18
2003/03/13	05:27:50	0.000	0.15
2003/03/13	05:27:55	0.000	0.13
2003/03/13	05:28:00	0.000	0.17
2003/03/13	05:28:05	0.000	0.18
2003/03/13	05:28:10	0.000	0.13
2003/03/13	05:28:15	0.000	0.17
2003/03/13	05:28:20	0.000	0.12
2003/03/13	05:28:25	0.000	0.15
2003/03/13	05:28:30	0.000	0.14
2003/03/13	05:28:35	0.000	0.15
2003/03/13	05:28:40	0.000	0.18
2003/03/13	05:28:45	0.000	0.13
2003/03/13	05:28:50	0.000	0.18
2003/03/13	05:28:55	0.000	0.18
2003/03/13	05:29:00	0.000	0.18
2003/03/13	05:29:05	0.000	0.15
2003/03/13	05:29:10	0.000	0.18
2003/03/13	05:29:15	0.000	0.18
2003/03/13	05:29:20	0.000	0.14
2003/03/13	05:29:25	0.000	0.19
2003/03/13	05:29:30	0.000	0.14
2003/03/13	05:29:35	0.000	0.18
2003/03/13	05:29:40	0.000	0.18
2003/03/13	05:29:45	0.000	0.15
2003/03/13	05:29:50	0.000	0.18
2003/03/13	05:29:55	0.000	0.14
2003/03/13	05:30:00	0.000	0.17
2003/03/13	05:30:05	0.000	0.17
2003/03/13	05:30:10	0.000	0.17
2003/03/13	05:30:15	0.000	0.18
2003/03/13	05:30:20	0.000	0.20
2003/03/13	05:30:25	0.000	0.19
2003/03/13	05:30:30	0.000	0.18
2003/03/13	05:30:35	0.000	0.21
2003/03/13	05:30:40	0.000	0.17
2003/03/13	05:30:45	0.000	0.18
2003/03/13	05:30:50	0.000	0.20
2003/03/13	05:30:55	0.000	0.18
2003/03/13	05:31:00	0.000	0.20
2003/03/13	05:31:05	0.000	0.18
2003/03/13	05:31:10	0.000	0.20
2003/03/13	05:31:15	0.000	0.20
2003/03/13	05:31:20	0.000	0.20
2003/03/13	05:31:25	0.000	0.21
2003/03/13	05:31:30	0.000	0.22
2003/03/13	05:31:35	0.000	0.21
2003/03/13	05:31:40	0.000	0.18
2003/03/13	05:31:45	0.000	0.23
2003/03/13	05:31:50	0.000	0.20
2003/03/13	05:31:55	0.000	0.20
2003/03/13	05:32:00	0.000	0.22
2003/03/13	05:32:05	0.000	0.20
2003/03/13	05:32:10	0.000	0.21
2003/03/13	05:32:15	0.000	0.20
2003/03/13	05:32:20	0.000	0.23
2003/03/13	05:32:25	0.000	0.23
2003/03/13	05:32:30	0.000	0.21
2003/03/13	05:32:35	0.000	0.25
2003/03/13	05:32:40	0.000	0.25
2003/03/13	05:32:45	0.000	0.23
2003/03/13	05:32:50	0.000	0.21
2003/03/13	05:32:55	0.000	0.28
2003/03/13	05:33:00	0.000	0.24
2003/03/13	05:33:05	0.000	0.22
2003/03/13	05:33:10	0.000	0.28
2003/03/13	05:33:15	0.000	0.22
2003/03/13	05:33:20	0.000	0.24
2003/03/13	05:33:25	0.000	0.22
2003/03/13	05:33:30	0.000	0.24
2003/03/13	05:33:35	0.000	0.25
2003/03/13	05:33:40	0.000	0.23
2003/03/13	05:33:45	0.000	0.28
2003/03/13	05:33:50	0.000	0.28
2003/03/13	05:33:55	0.000	0.25
2003/03/13	05:34:00	0.000	0.23
2003/03/13	05:34:05	0.000	0.28
2003/03/13	05:34:10	0.000	0.25
2003/03/13	05:34:15	0.000	0.22
2003/03/13	05:34:20	0.000	0.27
2003/03/13	05:34:25	0.000	0.22
2003/03/13	05:34:30	0.000	0.25
2003/03/13	05:34:35	0.000	0.23
2003/03/13	05:34:40	0.000	0.24

0.05

RESERVED FOR AGENCY

0.14

RESERVED FOR AGENCY

2003/03/13	05:34:45	0.000	0.28
2003/03/13	05:34:50	0.000	0.23
2003/03/13	05:34:55	0.000	0.28
2003/03/13	05:35:00	0.000	0.26
2003/03/13	05:35:05	0.000	0.25
2003/03/13	05:35:10	0.000	0.24
2003/03/13	05:35:15	0.000	0.28
2003/03/13	05:35:20	0.000	0.25
2003/03/13	05:35:25	0.000	0.23
2003/03/13	05:35:30	0.000	0.28
2003/03/13	05:35:35	0.000	0.23
2003/03/13	05:35:40	0.000	0.28
2003/03/13	05:35:45	0.000	0.28
2003/03/13	05:35:50	0.000	0.25
2003/03/13	05:35:55	0.000	0.28
2003/03/13	05:36:00	0.000	0.25
2003/03/13	05:36:05	0.000	0.27
2003/03/13	05:36:10	0.000	0.27
2003/03/13	05:36:15	0.000	0.28
2003/03/13	05:36:20	0.000	0.27
2003/03/13	05:36:25	0.000	0.28
2003/03/13	05:36:30	0.000	0.28
2003/03/13	05:36:35	0.000	0.25
2003/03/13	05:36:40	0.000	0.30
2003/03/13	05:36:45	0.000	0.28
2003/03/13	05:36:50	0.000	0.27
2003/03/13	05:36:55	0.000	0.25
2003/03/13	05:37:00	0.000	0.27
2003/03/13	05:37:05	0.000	0.29
2003/03/13	05:37:10	0.000	0.28
2003/03/13	05:37:15	0.000	0.29
2003/03/13	05:37:20	0.000	0.28
2003/03/13	05:37:25	0.000	0.19
2003/03/13	05:37:30	0.000	0.15
2003/03/13	05:37:35	0.000	0.12
2003/03/13	05:37:40	0.000	0.08
2003/03/13	05:37:45	0.000	0.02
2003/03/13	05:37:50	0.000	0.06
2003/03/13	05:37:55	0.000	0.01
2003/03/13	05:38:00	0.000	-0.01
2003/03/13	05:38:05	0.000	0.02
2003/03/13	05:38:10	0.000	0.02
2003/03/13	05:38:15	0.000	0.09
2003/03/13	05:38:20	0.000	0.09
2003/03/13	05:38:25	0.000	0.10
2003/03/13	05:38:30	0.000	0.08
2003/03/13	05:38:35	0.000	0.05
2003/03/13	05:38:40	0.000	0.08
2003/03/13	05:38:45	0.000	0.04
2003/03/13	05:38:50	0.000	0.02
2003/03/13	05:38:55	0.000	-0.01
2003/03/13	05:39:00	0.000	0.04
2003/03/13	05:39:05	0.000	0.01
2003/03/13	05:39:10	0.000	-0.01
2003/03/13	05:39:15	0.000	0.02
2003/03/13	05:39:20	0.000	-0.01
2003/03/13	05:39:25	0.000	0.01
2003/03/13	05:39:30	0.000	-0.01
2003/03/13	05:39:35	0.000	0.01
2003/03/13	05:39:40	0.000	0.01
2003/03/13	05:39:45	0.000	-0.01
2003/03/13	05:39:50	0.000	0.02
2003/03/13	05:39:55	0.000	0.01
2003/03/13	05:40:00	0.000	0.01
2003/03/13	05:40:05	0.000	-0.01
2003/03/13	05:40:10	0.000	0.03
2003/03/13	05:40:15	0.000	0.01
2003/03/13	05:40:20	0.000	-0.02
2003/03/13	05:40:25	0.000	0.03
2003/03/13	05:40:30	0.000	-0.02
2003/03/13	05:40:35	0.000	0.01
2003/03/13	05:40:40	0.000	0.01
2003/03/13	05:40:45	0.000	0.03
2003/03/13	05:40:50	0.000	0.06
2003/03/13	05:40:55	0.000	0.03
2003/03/13	05:41:00	0.000	0.06
2003/03/13	05:41:05	0.000	0.07
2003/03/13	05:41:10	0.000	0.09
2003/03/13	05:41:15	0.000	0.07
2003/03/13	05:41:20	0.000	0.10
2003/03/13	05:41:25	0.000	0.09
2003/03/13	05:41:30	0.000	0.07
2003/03/13	05:41:35	0.000	0.12
2003/03/13	05:41:40	0.000	0.07
2003/03/13	05:41:45	0.000	0.09
2003/03/13	05:41:50	0.000	0.10
2003/03/13	05:41:55	0.000	0.10
2003/03/13	05:42:00	0.000	0.12
2003/03/13	05:42:05	0.000	0.09
2003/03/13	05:42:10	0.000	0.12
2003/03/13	05:42:15	0.000	0.12
2003/03/13	05:42:20	0.000	0.11
2003/03/13	05:42:25	0.000	0.12
2003/03/13	05:42:30	0.000	0.14
2003/03/13	05:42:35	0.000	0.13
2003/03/13	05:42:40	0.000	0.09
2003/03/13	05:42:45	0.000	0.14
2003/03/13	05:42:50	0.000	0.10
2003/03/13	05:42:55	0.000	0.11
2003/03/13	05:43:00	0.000	0.12
2003/03/13	05:43:05	0.000	0.10
2003/03/13	05:43:10	0.000	0.11
2003/03/13	05:43:15	0.000	0.09
2003/03/13	05:43:20	0.000	0.13
2003/03/13	05:43:25	0.000	0.12
2003/03/13	05:43:30	0.000	0.11
2003/03/13	05:43:35	0.000	0.12
2003/03/13	05:43:40	0.000	0.14
2003/03/13	05:43:45	0.000	0.13
2003/03/13	05:43:50	0.000	0.09
2003/03/13	05:43:55	0.000	0.16
2003/03/13	05:44:00	0.000	0.12
2003/03/13	05:44:05	0.000	0.11
2003/03/13	05:44:10	0.000	0.14
2003/03/13	05:44:15	0.000	0.11
2003/03/13	05:44:20	0.000	0.12
2003/03/13	05:44:25	0.000	0.11
2003/03/13	05:44:30	0.000	0.13
2003/03/13	05:44:35	0.000	0.13
2003/03/13	05:44:40	0.000	0.12
2003/03/13	05:44:45	0.000	0.15
2003/03/13	05:44:50	0.000	0.16
2003/03/13	05:44:55	0.000	0.13
2003/03/13	05:45:00	0.000	0.11
2003/03/13	05:45:05	0.000	0.16
2003/03/13	05:45:10	0.000	0.14
2003/03/13	05:45:15	0.000	0.12
2003/03/13	05:45:20	0.000	0.16
2003/03/13	05:45:25	0.000	0.12
2003/03/13	05:45:30	0.000	0.14
2003/03/13	05:45:35	0.000	0.13
2003/03/13	05:45:40	0.000	0.14
2003/03/13	05:45:45	0.000	0.15
2003/03/13	05:45:50	0.000	0.13

0.22

05:34:45-05:45:50

0.15

05:40:00-05:45:50

0.09

05:45:00-05:45:50

2003/03/13 05:48:55 0.000 0.16
2003/03/13 05:48:00 0.000 0.17
2003/03/13 05:48:05 0.000 0.16
2003/03/13 05:48:10 0.000 0.14
2003/03/13 05:48:15 0.000 0.18
2003/03/13 05:48:20 0.000 0.16
2003/03/13 05:48:25 0.000 0.13
2003/03/13 05:48:30 0.000 0.18
2003/03/13 05:48:35 0.000 0.13
2003/03/13 05:48:40 0.000 0.16
2003/03/13 05:48:45 0.000 0.16
2003/03/13 05:48:50 0.000 0.15
2003/03/13 05:48:55 0.000 0.17
2003/03/13 05:47:00 0.000 0.14
2003/03/13 05:47:05 0.000 0.17
2003/03/13 05:47:10 0.000 0.17
2003/03/13 05:47:15 0.000 0.17
2003/03/13 05:47:20 0.000 0.16
2003/03/13 05:47:25 0.000 0.19
2003/03/13 05:47:30 0.000 0.17
2003/03/13 05:47:35 0.000 0.15
2003/03/13 05:47:40 0.000 0.19
2003/03/13 05:47:45 0.000 0.15
2003/03/13 05:47:50 0.000 0.17
2003/03/13 05:47:55 0.000 0.18
2003/03/13 05:48:00 0.000 0.17
2003/03/13 05:48:05 0.000 0.19
2003/03/13 05:48:10 0.000 0.16
2003/03/13 05:48:15 0.000 0.18
2003/03/13 05:48:20 0.000 0.19
2003/03/13 05:48:25 0.000 0.19
2003/03/13 05:48:30 0.000 0.20
2003/03/13 05:48:35 0.000 0.22
2003/03/13 05:48:40 0.000 0.21
2003/03/13 05:48:45 0.000 0.17
2003/03/13 05:48:50 0.000 0.22
2003/03/13 05:48:55 0.000 0.18
2003/03/13 05:48:00 0.000 0.19
2003/03/13 05:48:05 0.000 0.21
2003/03/13 05:48:10 0.000 0.18
2003/03/13 05:48:15 0.000 0.20
2003/03/13 05:48:20 0.000 0.18
2003/03/13 05:48:25 0.000 0.21
2003/03/13 05:48:30 0.000 0.20
2003/03/13 05:48:35 0.000 0.20
2003/03/13 05:48:40 0.000 0.23
2003/03/13 05:48:45 0.000 0.21
2003/03/13 05:48:50 0.000 0.23
2003/03/13 05:48:55 0.000 0.19
2003/03/13 05:50:00 0.000 0.24
2003/03/13 05:50:05 0.000 0.21
2003/03/13 05:50:10 0.000 0.20
2003/03/13 05:50:15 0.000 0.23
2003/03/13 05:50:20 0.000 0.20
2003/03/13 05:50:25 0.000 0.22
2003/03/13 05:50:30 0.000 0.20
2003/03/13 05:50:35 0.000 0.23
2003/03/13 05:50:40 0.000 0.23
2003/03/13 05:50:45 0.000 0.22
2003/03/13 05:50:50 0.000 0.25
2003/03/13 05:50:55 0.000 0.28
2003/03/13 05:51:00 0.000 0.24
2003/03/13 05:51:05 0.000 0.23
2003/03/13 05:51:10 0.000 0.27
2003/03/13 05:51:15 0.000 0.25
2003/03/13 05:51:20 0.000 0.23
2003/03/13 05:51:25 0.000 0.27
2003/03/13 05:51:30 0.000 0.22
2003/03/13 05:51:35 0.000 0.25
2003/03/13 05:51:40 0.000 0.23
2003/03/13 05:51:45 0.000 0.24
2003/03/13 05:51:50 0.000 0.25
2003/03/13 05:51:55 0.000 0.23
2003/03/13 05:52:00 0.000 0.28
2003/03/13 05:52:05 0.000 0.26
2003/03/13 05:52:10 0.000 0.25
2003/03/13 05:52:15 0.000 0.25
2003/03/13 05:52:20 0.000 0.25
2003/03/13 05:52:25 0.000 0.28
2003/03/13 05:52:30 0.000 0.24
2003/03/13 05:52:35 0.000 0.25
2003/03/13 05:52:40 0.000 0.23
2003/03/13 05:52:45 0.000 0.25
2003/03/13 05:52:50 0.000 0.25
2003/03/13 05:52:55 0.000 0.28
2003/03/13 05:53:00 0.000 0.28
2003/03/13 05:53:05 0.000 0.24
2003/03/13 05:53:10 0.000 0.27
2003/03/13 05:53:15 0.000 0.27
2003/03/13 05:53:20 0.000 0.27
2003/03/13 05:53:25 0.000 0.27
2003/03/13 05:53:30 0.000 0.30
2003/03/13 05:53:35 0.000 0.28
2003/03/13 05:53:40 0.000 0.25
2003/03/13 05:53:45 0.000 0.26
2003/03/13 05:53:50 0.000 0.26
2003/03/13 05:53:55 0.000 0.27
2003/03/13 05:54:00 0.000 0.29
2003/03/13 05:54:05 0.000 0.27
2003/03/13 05:54:10 0.000 0.29
2003/03/13 05:54:15 0.000 0.28
2003/03/13 05:54:20 0.000 0.29
2003/03/13 05:54:25 0.000 0.28
2003/03/13 05:54:30 0.000 0.28
2003/03/13 05:54:35 0.000 0.29
2003/03/13 05:54:40 0.000 0.31
2003/03/13 05:54:45 0.000 0.27
2003/03/13 05:54:50 0.000 0.18
2003/03/13 05:54:55 0.000 0.18
2003/03/13 05:55:00 0.000 0.09
2003/03/13 05:55:05 0.000 0.08
2003/03/13 05:55:10 0.000 0.08
2003/03/13 05:55:15 0.000 0.01
2003/03/13 05:55:20 0.000 0.01
2003/03/13 05:55:25 0.000 -0.01
2003/03/13 05:55:30 0.000 0.01
2003/03/13 05:55:35 0.000 0.01
2003/03/13 05:55:40 0.000 -0.01
2003/03/13 05:55:45 0.000 0.04
2003/03/13 05:55:50 0.000 0.12
2003/03/13 05:55:55 0.000 0.16
2003/03/13 05:56:00 0.000 0.19
2003/03/13 05:56:05 0.000 0.29
2003/03/13 05:56:10 0.000 0.25
2003/03/13 05:56:15 0.000 0.24
2003/03/13 05:56:20 0.000 0.29
2003/03/13 05:56:25 0.000 0.28
2003/03/13 05:56:30 0.000 0.24
2003/03/13 05:56:35 0.000 0.17
2003/03/13 05:56:40 0.000 0.14
2003/03/13 05:56:45 0.000 0.10
2003/03/13 05:56:50 0.000 0.05
2003/03/13 05:56:55 0.000 0.06
2003/03/13 05:57:00 0.000 0.04

0.17

2003/03/13 05:56:55

0.25

2003/03/13 05:56:55

2003/03/13	05:57:05	0.000	0.01
2003/03/13	05:57:10	0.000	-0.01
2003/03/13	05:57:15	0.000	0.04
2003/03/13	05:57:20	0.000	0.01
2003/03/13	05:57:25	0.000	-0.02
2003/03/13	05:57:30	0.000	0.03
2003/03/13	05:57:35	0.000	-0.02
2003/03/13	05:57:40	0.000	0.01
2003/03/13	05:57:45	0.000	-0.01
2003/03/13	05:57:50	0.000	0.00
2003/03/13	05:57:55	0.000	0.01
2003/03/13	05:58:00	0.000	-0.01
2003/03/13	05:58:05	0.000	0.02
2003/03/13	05:58:10	0.000	0.01
2003/03/13	05:58:15	0.000	0.01
2003/03/13	05:58:20	0.000	0.00
2003/03/13	05:58:25	0.000	0.03
2003/03/13	05:58:30	0.000	0.01
2003/03/13	05:58:35	0.000	-0.02
2003/03/13	05:58:40	0.000	0.03
2003/03/13	05:58:45	0.000	-0.02
2003/03/13	05:58:50	0.000	0.00
2003/03/13	05:58:55	0.000	0.00
2003/03/13	05:59:00	0.000	0.00
2003/03/13	05:59:05	0.000	0.02
2003/03/13	05:59:10	0.000	-0.01
2003/03/13	05:59:15	0.000	0.03
2003/03/13	05:59:20	0.000	0.03
2003/03/13	05:59:25	0.000	0.04
2003/03/13	05:59:30	0.000	0.05
2003/03/13	05:59:35	0.000	0.07
2003/03/13	05:59:40	0.000	0.08
2003/03/13	05:59:45	0.000	0.04
2003/03/13	05:59:50	0.000	0.09
2003/03/13	05:59:55	0.000	0.08
2003/03/13	06:00:00	0.000	0.07
2003/03/13	06:00:05	0.000	0.09
2003/03/13	06:00:10	0.000	0.07
2003/03/13	06:00:15	0.000	0.08
2003/03/13	06:00:20	0.000	0.08
2003/03/13	06:00:25	0.000	0.08
2003/03/13	06:00:30	0.000	0.09
2003/03/13	06:00:35	0.000	0.08
2003/03/13	06:00:40	0.000	0.10
2003/03/13	06:00:45	0.000	0.11
2003/03/13	06:00:50	0.000	0.10
2003/03/13	06:00:55	0.000	0.07
2003/03/13	06:01:00	0.000	0.12
2003/03/13	06:01:05	0.000	0.08
2003/03/13	06:01:10	0.000	0.08
2003/03/13	06:01:15	0.000	0.11
2003/03/13	06:01:20	0.000	0.07
2003/03/13	06:01:25	0.000	0.09
2003/03/13	06:01:30	0.000	0.07
2003/03/13	06:01:35	0.000	0.10
2003/03/13	06:01:40	0.000	0.10
2003/03/13	06:01:45	0.000	0.08
2003/03/13	06:01:50	0.000	0.10
2003/03/13	06:01:55	0.000	0.12
2003/03/13	06:02:00	0.000	0.11
2003/03/13	06:02:05	0.000	0.08
2003/03/13	06:02:10	0.000	0.13
2003/03/13	06:02:15	0.000	0.11
2003/03/13	06:02:20	0.000	0.09
2003/03/13	06:02:25	0.000	0.13
2003/03/13	06:02:30	0.000	0.09
2003/03/13	06:02:35	0.000	0.11
2003/03/13	06:02:40	0.000	0.10
2003/03/13	06:02:45	0.000	0.12
2003/03/13	06:02:50	0.000	0.12
2003/03/13	06:02:55	0.000	0.10
2003/03/13	06:03:00	0.000	0.14
2003/03/13	06:03:05	0.000	0.15
2003/03/13	06:03:10	0.000	0.13
2003/03/13	06:03:15	0.000	0.11
2003/03/13	06:03:20	0.000	0.16
2003/03/13	06:03:25	0.000	0.14
2003/03/13	06:03:30	0.000	0.11
2003/03/13	06:03:35	0.000	0.15
2003/03/13	06:03:40	0.000	0.11
2003/03/13	06:03:45	0.000	0.13
2003/03/13	06:03:50	0.000	0.13
2003/03/13	06:03:55	0.000	0.13
2003/03/13	06:04:00	0.000	0.13
2003/03/13	06:04:05	0.000	0.12
2003/03/13	06:04:10	0.000	0.15
2003/03/13	06:04:15	0.000	0.15
2003/03/13	06:04:20	0.000	0.15
2003/03/13	06:04:25	0.000	0.14
2003/03/13	06:04:30	0.000	0.17
2003/03/13	06:04:35	0.000	0.16
2003/03/13	06:04:40	0.000	0.13
2003/03/13	06:04:45	0.000	0.18
2003/03/13	06:04:50	0.000	0.14
2003/03/13	06:04:55	0.000	0.16
2003/03/13	06:05:00	0.000	0.15
2003/03/13	06:05:05	0.000	0.15
2003/03/13	06:05:10	0.000	0.16
2003/03/13	06:05:15	0.000	0.14
2003/03/13	06:05:20	0.000	0.17
2003/03/13	06:05:25	0.000	0.18
2003/03/13	06:05:30	0.000	0.16
2003/03/13	06:05:35	0.000	0.19
2003/03/13	06:05:40	0.000	0.21
2003/03/13	06:05:45	0.000	0.20
2003/03/13	06:05:50	0.000	0.17
2003/03/13	06:05:55	0.000	0.22
2003/03/13	06:06:00	0.000	0.18
2003/03/13	06:06:05	0.000	0.20
2003/03/13	06:06:10	0.000	0.22
2003/03/13	06:06:15	0.000	0.20
2003/03/13	06:06:20	0.000	0.22
2003/03/13	06:06:25	0.000	0.20
2003/03/13	06:06:30	0.000	0.23
2003/03/13	06:06:35	0.000	0.23
2003/03/13	06:06:40	0.000	0.22
2003/03/13	06:06:45	0.000	0.24
2003/03/13	06:06:50	0.000	0.26
2003/03/13	06:06:55	0.000	0.26
2003/03/13	06:07:00	0.000	0.22
2003/03/13	06:07:05	0.000	0.27
2003/03/13	06:07:10	0.000	0.24
2003/03/13	06:07:15	0.000	0.23
2003/03/13	06:07:20	0.000	0.26
2003/03/13	06:07:25	0.000	0.28
2003/03/13	06:07:30	0.000	0.25
2003/03/13	06:07:35	0.000	0.23
2003/03/13	06:07:40	0.000	0.26
2003/03/13	06:07:45	0.000	0.26
2003/03/13	06:07:50	0.000	0.26
2003/03/13	06:07:55	0.000	0.29
2003/03/13	06:08:00	0.000	0.28
2003/03/13	06:08:05	0.000	0.27
2003/03/13	06:08:10	0.000	0.24

0.08

06:00:58:16:15:57

0.11

06:06:04:16:15:57

2003/03/13	06:08:15	0.000	0.28
2003/03/13	06:08:20	0.000	0.28
2003/03/13	06:08:25	0.000	0.24
2003/03/13	06:08:30	0.000	0.27
2003/03/13	06:08:35	0.000	0.23
2003/03/13	06:08:40	0.000	0.24
2003/03/13	06:08:45	0.000	0.23
2003/03/13	06:08:50	0.000	0.26
2003/03/13	06:08:55	0.000	0.26
2003/03/13	06:09:00	0.000	0.23
2003/03/13	06:09:05	0.000	0.28
2003/03/13	06:09:10	0.000	0.28
2003/03/13	06:09:15	0.000	0.25
2003/03/13	06:09:20	0.000	0.24
2003/03/13	06:09:25	0.000	0.28
2003/03/13	06:09:30	0.000	0.28
2003/03/13	06:09:35	0.000	0.22
2003/03/13	06:09:40	0.000	0.27
2003/03/13	06:09:45	0.000	0.22
2003/03/13	06:09:50	0.000	0.25
2003/03/13	06:09:55	0.000	0.24
2003/03/13	06:10:00	0.000	0.24
2003/03/13	06:10:05	0.000	0.25
2003/03/13	06:10:10	0.000	0.23
2003/03/13	06:10:15	0.000	0.26
2003/03/13	06:10:20	0.000	0.28
2003/03/13	06:10:25	0.000	0.25
2003/03/13	06:10:30	0.000	0.25
2003/03/13	06:10:35	0.000	0.28
2003/03/13	06:10:40	0.000	0.28
2003/03/13	06:10:45	0.000	0.23
2003/03/13	06:10:50	0.000	0.28
2003/03/13	06:10:55	0.000	0.23
2003/03/13	06:11:00	0.000	0.25
2003/03/13	06:11:05	0.000	0.25
2003/03/13	06:11:10	0.000	0.24
2003/03/13	06:11:15	0.000	0.27
2003/03/13	06:11:20	0.000	0.23
2003/03/13	06:11:25	0.000	0.28
2003/03/13	06:11:30	0.000	0.28
2003/03/13	06:11:35	0.000	0.28
2003/03/13	06:11:40	0.000	0.27
2003/03/13	06:11:45	0.000	0.29
2003/03/13	06:11:50	0.000	0.27
2003/03/13	06:11:55	0.000	0.25
2003/03/13	06:12:00	0.000	0.30
2003/03/13	06:12:05	0.000	0.26
2003/03/13	06:12:10	0.000	0.28
2003/03/13	06:12:15	0.000	0.28
2003/03/13	06:12:20	0.000	0.28
2003/03/13	06:12:25	0.000	0.28
2003/03/13	06:12:30	0.000	0.25
2003/03/13	06:12:35	0.000	0.28
2003/03/13	06:12:40	0.000	0.28
2003/03/13	06:12:45	0.000	0.27
2003/03/13	06:12:50	0.000	0.29
2003/03/13	06:12:55	0.000	0.30
2003/03/13	06:13:00	0.000	0.28
2003/03/13	06:13:05	0.000	0.28
2003/03/13	06:13:10	0.000	0.31
2003/03/13	06:13:15	0.000	0.28
2003/03/13	06:13:20	0.000	0.27
2003/03/13	06:13:25	0.000	0.30
2003/03/13	06:13:30	0.000	0.27
2003/03/13	06:13:35	0.000	0.28
2003/03/13	06:13:40	0.000	0.28
2003/03/13	06:13:45	0.000	0.28
2003/03/13	06:13:50	0.000	0.25
2003/03/13	06:13:55	0.000	0.18
2003/03/13	06:14:00	0.000	0.14
2003/03/13	06:14:05	0.000	0.12
2003/03/13	06:14:10	0.000	0.07
2003/03/13	06:14:15	0.000	0.02
2003/03/13	06:14:20	0.000	0.05
2003/03/13	06:14:25	0.000	0.02
2003/03/13	06:14:30	0.000	-0.01
2003/03/13	06:14:35	0.000	0.03
2003/03/13	06:14:40	0.000	0.04
2003/03/13	06:14:45	0.000	0.10
2003/03/13	06:14:50	0.000	0.09
2003/03/13	06:14:55	0.000	0.08
2003/03/13	06:15:00	0.000	0.07
2003/03/13	06:15:05	0.000	0.03
2003/03/13	06:15:10	0.000	0.04
2003/03/13	06:15:15	0.000	0.02
2003/03/13	06:15:20	0.000	0.01
2003/03/13	06:15:25	0.000	-0.01
2003/03/13	06:15:30	0.000	0.03
2003/03/13	06:15:35	0.000	0.02
2003/03/13	06:15:40	0.000	-0.02
2003/03/13	06:15:45	0.000	0.03
2003/03/13	06:15:50	0.000	-0.02
2003/03/13	06:15:55	0.000	0.01
2003/03/13	06:16:00	0.000	0.00
2003/03/13	06:16:05	0.000	0.00
2003/03/13	06:16:10	0.000	0.00
2003/03/13	06:16:15	0.000	-0.01
2003/03/13	06:16:20	0.000	0.02
2003/03/13	06:16:25	0.000	0.01
2003/03/13	06:16:30	0.000	0.01
2003/03/13	06:16:35	0.000	0.00
2003/03/13	06:16:40	0.000	0.03
2003/03/13	06:16:45	0.000	0.01
2003/03/13	06:16:50	0.000	-0.02
2003/03/13	06:16:55	0.000	0.04
2003/03/13	06:17:00	0.000	0.01
2003/03/13	06:17:05	0.000	0.04
2003/03/13	06:17:10	0.000	0.04
2003/03/13	06:17:15	0.000	0.04
2003/03/13	06:17:20	0.000	0.07
2003/03/13	06:17:25	0.000	0.04
2003/03/13	06:17:30	0.000	0.08
2003/03/13	06:17:35	0.000	0.08
2003/03/13	06:17:40	0.000	0.08
2003/03/13	06:17:45	0.000	0.08
2003/03/13	06:17:50	0.000	0.10
2003/03/13	06:17:55	0.000	0.09
2003/03/13	06:18:00	0.000	0.07
2003/03/13	06:18:05	0.000	0.12
2003/03/13	06:18:10	0.000	0.07
2003/03/13	06:18:15	0.000	0.09
2003/03/13	06:18:20	0.000	0.10
2003/03/13	06:18:25	0.000	0.08
2003/03/13	06:18:30	0.000	0.11
2003/03/13	06:18:35	0.000	0.08
2003/03/13	06:18:40	0.000	0.11
2003/03/13	06:18:45	0.000	0.11
2003/03/13	06:18:50	0.000	0.10
2003/03/13	06:18:55	0.000	0.12
2003/03/13	06:19:00	0.000	0.14
2003/03/13	06:19:05	0.000	0.13
2003/03/13	06:19:10	0.000	0.09
2003/03/13	06:19:15	0.000	0.15
2003/03/13	06:19:20	0.000	0.11

0.23

06:08:20 m/06:08:20

0.22

06:12:00 m/06:12:00

2003/03/13	08:18:25	0.000	0.10
2003/03/13	08:18:30	0.000	0.13
2003/03/13	08:18:35	0.000	0.10
2003/03/13	08:18:40	0.000	0.12
2003/03/13	08:18:45	0.000	0.10
2003/03/13	08:18:50	0.000	0.13
2003/03/13	08:18:55	0.000	0.14
2003/03/13	08:20:00	0.000	0.12
2003/03/13	08:20:05	0.000	0.13
2003/03/13	08:20:10	0.000	0.16
2003/03/13	08:20:15	0.000	0.14
2003/03/13	08:20:20	0.000	0.12
2003/03/13	08:20:25	0.000	0.17
2003/03/13	08:20:30	0.000	0.16
2003/03/13	08:20:35	0.000	0.12
2003/03/13	08:20:40	0.000	0.16
2003/03/13	08:20:45	0.000	0.13
2003/03/13	08:20:50	0.000	0.15
2003/03/13	08:20:55	0.000	0.14
2003/03/13	08:21:00	0.000	0.15
2003/03/13	08:21:05	0.000	0.17
2003/03/13	08:21:10	0.000	0.14
2003/03/13	08:21:15	0.000	0.18
2003/03/13	08:21:20	0.000	0.17
2003/03/13	08:21:25	0.000	0.16
2003/03/13	08:21:30	0.000	0.15
2003/03/13	08:21:35	0.000	0.19
2003/03/13	08:21:40	0.000	0.18
2003/03/13	08:21:45	0.000	0.15
2003/03/13	08:21:50	0.000	0.19
2003/03/13	08:21:55	0.000	0.15
2003/03/13	08:22:00	0.000	0.18
2003/03/13	08:22:05	0.000	0.17
2003/03/13	08:22:10	0.000	0.16
2003/03/13	08:22:15	0.000	0.19
2003/03/13	08:22:20	0.000	0.17
2003/03/13	08:22:25	0.000	0.20
2003/03/13	08:22:30	0.000	0.20
2003/03/13	08:22:35	0.000	0.20
2003/03/13	08:22:40	0.000	0.20
2003/03/13	08:22:45	0.000	0.23
2003/03/13	08:22:50	0.000	0.22
2003/03/13	08:22:55	0.000	0.19
2003/03/13	08:23:00	0.000	0.24
2003/03/13	08:23:05	0.000	0.20
2003/03/13	08:23:10	0.000	0.22
2003/03/13	08:23:15	0.000	0.22
2003/03/13	08:23:20	0.000	0.22
2003/03/13	08:23:25	0.000	0.24
2003/03/13	08:23:30	0.000	0.21
2003/03/13	08:23:35	0.000	0.24
2003/03/13	08:23:40	0.000	0.24
2003/03/13	08:23:45	0.000	0.24
2003/03/13	08:23:50	0.000	0.26
2003/03/13	08:23:55	0.000	0.27
2003/03/13	08:24:00	0.000	0.25
2003/03/13	08:24:05	0.000	0.22
2003/03/13	08:24:10	0.000	0.27
2003/03/13	08:24:15	0.000	0.23
2003/03/13	08:24:20	0.000	0.24
2003/03/13	08:24:25	0.000	0.28
2003/03/13	08:24:30	0.000	0.24
2003/03/13	08:24:35	0.000	0.28
2003/03/13	08:24:40	0.000	0.24
2003/03/13	08:24:45	0.000	0.28
2003/03/13	08:24:50	0.000	0.28
2003/03/13	08:24:55	0.000	0.25
2003/03/13	08:25:00	0.000	0.28
2003/03/13	08:25:05	0.000	0.29
2003/03/13	08:25:10	0.000	0.28
2003/03/13	08:25:15	0.000	0.25
2003/03/13	08:25:20	0.000	0.30
2003/03/13	08:25:25	0.000	0.27
2003/03/13	08:25:30	0.000	0.28
2003/03/13	08:25:35	0.000	0.29
2003/03/13	08:25:40	0.000	0.29
2003/03/13	08:25:45	0.000	0.29
2003/03/13	08:25:50	0.000	0.28
2003/03/13	08:25:55	0.000	0.29
2003/03/13	08:26:00	0.000	0.29
2003/03/13	08:26:05	0.000	0.27
2003/03/13	08:26:10	0.000	0.30
2003/03/13	08:26:15	0.000	0.32
2003/03/13	08:26:20	0.000	0.31
2003/03/13	08:26:25	0.000	0.28
2003/03/13	08:26:30	0.000	0.34
2003/03/13	08:26:35	0.000	0.32
2003/03/13	08:26:40	0.000	0.30
2003/03/13	08:26:45	0.000	0.34
2003/03/13	08:26:50	0.000	0.30
2003/03/13	08:26:55	0.000	0.32
2003/03/13	08:27:00	0.000	0.31
2003/03/13	08:27:05	0.000	0.33
2003/03/13	08:27:10	0.000	0.34
2003/03/13	08:27:15	0.000	0.32
2003/03/13	08:27:20	0.000	0.36
2003/03/13	08:27:25	0.000	0.36
2003/03/13	08:27:30	0.000	0.38
2003/03/13	08:27:35	0.000	0.34
2003/03/13	08:27:40	0.000	0.39
2003/03/13	08:27:45	0.000	0.38
2003/03/13	08:27:50	0.000	0.34
2003/03/13	08:27:55	0.000	0.40
2003/03/13	08:28:00	0.000	0.35
2003/03/13	08:28:05	0.000	0.37
2003/03/13	08:28:10	0.000	0.37
2003/03/13	08:28:15	0.000	0.37
2003/03/13	08:28:20	0.000	0.37
2003/03/13	08:28:25	0.000	0.36
2003/03/13	08:28:30	0.000	0.38
2003/03/13	08:28:35	0.000	0.36
2003/03/13	08:28:40	0.000	0.38
2003/03/13	08:28:45	0.000	0.38
2003/03/13	08:28:50	0.000	0.40
2003/03/13	08:28:55	0.000	0.39
2003/03/13	08:29:00	0.000	0.36
2003/03/13	08:29:05	0.000	0.40
2003/03/13	08:29:10	0.000	0.39
2003/03/13	08:29:15	0.000	0.37
2003/03/13	08:29:20	0.000	0.36
2003/03/13	08:29:25	0.000	0.36
2003/03/13	08:29:30	0.000	0.39
2003/03/13	08:29:35	0.000	0.35
2003/03/13	08:29:40	0.000	0.38
2003/03/13	08:29:45	0.000	0.38
2003/03/13	08:29:50	0.000	0.37
2003/03/13	08:29:55	0.000	0.38
2003/03/13	08:30:00	0.000	0.40
2003/03/13	08:30:05	0.000	0.37
2003/03/13	08:30:10	0.000	0.38
2003/03/13	08:30:15	0.000	0.40
2003/03/13	08:30:20	0.000	0.38
2003/03/13	08:30:25	0.000	0.38
2003/03/13	08:30:30	0.000	0.38

0.08

08:20:50-08:21:00:23

0.20

08:24:45-08:24:55:24

0.34

08:29:55-09:30:05:23

2003/03/13	06:30:35	0.000	0.36
2003/03/13	06:30:40	0.000	0.36
2003/03/13	06:30:45	0.000	0.35
2003/03/13	06:30:50	0.000	0.37
2003/03/13	06:30:55	0.000	0.37
2003/03/13	06:31:00	0.000	0.38
2003/03/13	06:31:05	0.000	0.38
2003/03/13	06:31:10	0.000	0.38
2003/03/13	06:31:15	0.000	0.31
2003/03/13	06:31:20	0.000	0.20
2003/03/13	06:31:25	0.000	0.20
2003/03/13	06:31:30	0.000	0.12
2003/03/13	06:31:35	0.000	0.07
2003/03/13	06:31:40	0.000	0.07
2003/03/13	06:31:45	0.000	0.02
2003/03/13	06:31:50	0.000	0.02
2003/03/13	06:31:55	0.000	-0.01
2003/03/13	06:32:00	0.000	0.01
2003/03/13	06:32:05	0.000	0.01
2003/03/13	06:32:10	0.000	0.00
2003/03/13	06:32:15	0.000	0.08
2003/03/13	06:32:20	0.000	0.17
2003/03/13	06:32:25	0.000	0.22
2003/03/13	06:32:30	0.000	0.24
2003/03/13	06:32:35	0.000	0.32
2003/03/13	06:32:40	0.000	0.33
2003/03/13	06:32:45	0.000	0.32
2003/03/13	06:32:50	0.000	0.37
2003/03/13	06:32:55	0.000	0.32
2003/03/13	06:33:00	0.000	0.28
2003/03/13	06:33:05	0.000	0.21
2003/03/13	06:33:10	0.000	0.16
2003/03/13	06:33:15	0.000	0.12
2003/03/13	06:33:20	0.000	0.06
2003/03/13	06:33:25	0.000	0.07
2003/03/13	06:33:30	0.000	0.05
2003/03/13	06:33:35	0.000	0.03
2003/03/13	06:33:40	0.000	0.00
2003/03/13	06:33:45	0.000	0.03
2003/03/13	06:33:50	0.000	0.02
2003/03/13	06:33:55	0.000	-0.02
2003/03/13	06:34:00	0.000	0.03
2003/03/13	06:34:05	0.000	-0.02
2003/03/13	06:34:10	0.000	0.01
2003/03/13	06:34:15	0.000	0.00
2003/03/13	06:34:20	0.000	0.00
2003/03/13	06:34:25	0.000	0.00
2003/03/13	06:34:30	0.000	-0.01
2003/03/13	06:34:35	0.000	0.01
2003/03/13	06:34:40	0.000	0.00
2003/03/13	06:34:45	0.000	0.01
2003/03/13	06:34:50	0.000	0.01
2003/03/13	06:34:55	0.000	0.03
2003/03/13	06:35:00	0.000	0.01
2003/03/13	06:35:05	0.000	-0.02
2003/03/13	06:35:10	0.000	0.03
2003/03/13	06:35:15	0.000	-0.01
2003/03/13	06:35:20	0.000	0.00
2003/03/13	06:35:25	0.000	0.02
2003/03/13	06:35:30	0.000	0.02
2003/03/13	06:35:35	0.000	0.06
2003/03/13	06:35:40	0.000	0.02
2003/03/13	06:35:45	0.000	0.05
2003/03/13	06:35:50	0.000	0.05
2003/03/13	06:35:55	0.000	0.06
2003/03/13	06:36:00	0.000	0.07
2003/03/13	06:36:05	0.000	0.08
2003/03/13	06:36:10	0.000	0.07
2003/03/13	06:36:15	0.000	0.04
2003/03/13	06:36:20	0.000	0.09
2003/03/13	06:36:25	0.000	0.05
2003/03/13	06:36:30	0.000	0.05
2003/03/13	06:36:35	0.000	0.07
2003/03/13	06:36:40	0.000	0.06
2003/03/13	06:36:45	0.000	0.07
2003/03/13	06:36:50	0.000	0.04
2003/03/13	06:36:55	0.000	0.07
2003/03/13	06:37:00	0.000	0.07
2003/03/13	06:37:05	0.000	0.06
2003/03/13	06:37:10	0.000	0.08
2003/03/13	06:37:15	0.000	0.09
2003/03/13	06:37:20	0.000	0.07
2003/03/13	06:37:25	0.000	0.04
2003/03/13	06:37:30	0.000	0.09
2003/03/13	06:37:35	0.000	0.07
2003/03/13	06:37:40	0.000	0.06
2003/03/13	06:37:45	0.000	0.08
2003/03/13	06:37:50	0.000	0.05
2003/03/13	06:37:55	0.000	0.07
2003/03/13	06:38:00	0.000	0.05
2003/03/13	06:38:05	0.000	0.08
2003/03/13	06:38:10	0.000	0.09
2003/03/13	06:38:15	0.000	0.05
2003/03/13	06:38:20	0.000	0.06
2003/03/13	06:38:25	0.000	0.10
2003/03/13	06:38:30	0.000	0.09
2003/03/13	06:38:35	0.000	0.06
2003/03/13	06:38:40	0.000	0.11
2003/03/13	06:38:45	0.000	0.09
2003/03/13	06:38:50	0.000	0.08
2003/03/13	06:38:55	0.000	0.11
2003/03/13	06:39:00	0.000	0.07
2003/03/13	06:39:05	0.000	0.09
2003/03/13	06:39:10	0.000	0.08
2003/03/13	06:39:15	0.000	0.09
2003/03/13	06:39:20	0.000	0.10
2003/03/13	06:39:25	0.000	0.07
2003/03/13	06:39:30	0.000	0.11
2003/03/13	06:39:35	0.000	0.12
2003/03/13	06:39:40	0.000	0.11
2003/03/13	06:39:45	0.000	0.10
2003/03/13	06:39:50	0.000	0.13
2003/03/13	06:39:55	0.000	0.12
2003/03/13	06:40:00	0.000	0.09
2003/03/13	06:40:05	0.000	0.14
2003/03/13	06:40:10	0.000	0.10
2003/03/13	06:40:15	0.000	0.13
2003/03/13	06:40:20	0.000	0.12
2003/03/13	06:40:25	0.000	0.12
2003/03/13	06:40:30	0.000	0.13
2003/03/13	06:40:35	0.000	0.12
2003/03/13	06:40:40	0.000	0.15
2003/03/13	06:40:45	0.000	0.16
2003/03/13	06:40:50	0.000	0.16
2003/03/13	06:40:55	0.000	0.16
2003/03/13	06:41:00	0.000	0.18
2003/03/13	06:41:05	0.000	0.16
2003/03/13	06:41:10	0.000	0.13
2003/03/13	06:41:15	0.000	0.18
2003/03/13	06:41:20	0.000	0.14
2003/03/13	06:41:25	0.000	0.16
2003/03/13	06:41:30	0.000	0.16
2003/03/13	06:41:35	0.000	0.15
2003/03/13	06:41:40	0.000	0.17

0.17

BASE PRICE: 1000000

0.07

BASE PRICE: 1000000

2003/03/13 08:41:45 0.000 0.14
 2003/03/13 08:41:50 0.000 0.17
 2003/03/13 08:41:55 0.000 0.17
 2003/03/13 08:42:00 0.000 0.17
 2003/03/13 08:42:05 0.000 0.18
 2003/03/13 08:42:10 0.000 0.20
 2003/03/13 08:42:15 0.000 0.18
 2003/03/13 08:42:20 0.000 0.18
 2003/03/13 08:42:25 0.000 0.21
 2003/03/13 08:42:30 0.000 0.17
 2003/03/13 08:42:35 0.000 0.17
 2003/03/13 08:42:40 0.000 0.20
 2003/03/13 08:42:45 0.000 0.18
 2003/03/13 08:42:50 0.000 0.20
 2003/03/13 08:42:55 0.000 0.17
 2003/03/13 08:43:00 0.000 0.20
 2003/03/13 08:43:05 0.000 0.20
 2003/03/13 08:43:10 0.000 0.18
 2003/03/13 08:43:15 0.000 0.20
 2003/03/13 08:43:20 0.000 0.22
 2003/03/13 08:43:25 0.000 0.21
 2003/03/13 08:43:30 0.000 0.18
 2003/03/13 08:43:35 0.000 0.23
 2003/03/13 08:43:40 0.000 0.20
 2003/03/13 08:43:45 0.000 0.19
 2003/03/13 08:43:50 0.000 0.22
 2003/03/13 08:43:55 0.000 0.19
 2003/03/13 08:44:00 0.000 0.21
 2003/03/13 08:44:05 0.000 0.20
 2003/03/13 08:44:10 0.000 0.22
 2003/03/13 08:44:15 0.000 0.23
 2003/03/13 08:44:20 0.000 0.21
 2003/03/13 08:44:25 0.000 0.22
 2003/03/13 08:44:30 0.000 0.24
 2003/03/13 08:44:35 0.000 0.23
 2003/03/13 08:44:40 0.000 0.21
 2003/03/13 08:44:45 0.000 0.26
 2003/03/13 08:44:50 0.000 0.24
 2003/03/13 08:44:55 0.000 0.21
 2003/03/13 08:45:00 0.000 0.25
 2003/03/13 08:45:05 0.000 0.21
 2003/03/13 08:45:10 0.000 0.23
 2003/03/13 08:45:15 0.000 0.23
 2003/03/13 08:45:20 0.000 0.24
 2003/03/13 08:45:25 0.000 0.25
 2003/03/13 08:45:30 0.000 0.22
 2003/03/13 08:45:35 0.000 0.25
 2003/03/13 08:45:40 0.000 0.25
 2003/03/13 08:45:45 0.000 0.25
 2003/03/13 08:45:50 0.000 0.23
 2003/03/13 08:45:55 0.000 0.27
 2003/03/13 08:46:00 0.000 0.26
 2003/03/13 08:46:05 0.000 0.22
 2003/03/13 08:46:10 0.000 0.27
 2003/03/13 08:46:15 0.000 0.22
 2003/03/13 08:46:20 0.000 0.24
 2003/03/13 08:46:25 0.000 0.24
 2003/03/13 08:46:30 0.000 0.23
 2003/03/13 08:46:35 0.000 0.24
 2003/03/13 08:46:40 0.000 0.22
 2003/03/13 08:46:45 0.000 0.25
 2003/03/13 08:46:50 0.000 0.24
 2003/03/13 08:46:55 0.000 0.24
 2003/03/13 08:47:00 0.000 0.25
 2003/03/13 08:47:05 0.000 0.27
 2003/03/13 08:47:10 0.000 0.25
 2003/03/13 08:47:15 0.000 0.22
 2003/03/13 08:47:20 0.000 0.27
 2003/03/13 08:47:25 0.000 0.22
 2003/03/13 08:47:30 0.000 0.23
 2003/03/13 08:47:35 0.000 0.24
 2003/03/13 08:47:40 0.000 0.23
 2003/03/13 08:47:45 0.000 0.25
 2003/03/13 08:47:50 0.000 0.22
 2003/03/13 08:47:55 0.000 0.24
 2003/03/13 08:48:00 0.000 0.24
 2003/03/13 08:48:05 0.000 0.24
 2003/03/13 08:48:10 0.000 0.25
 2003/03/13 08:48:15 0.000 0.26
 2003/03/13 08:48:20 0.000 0.24
 2003/03/13 08:48:25 0.000 0.22
 2003/03/13 08:48:30 0.000 0.27
 2003/03/13 08:48:35 0.000 0.23
 2003/03/13 08:48:40 0.000 0.23
 2003/03/13 08:48:45 0.000 0.25
 2003/03/13 08:48:50 0.000 0.23
 2003/03/13 08:48:55 0.000 0.25
 2003/03/13 08:49:00 0.000 0.22
 2003/03/13 08:49:05 0.000 0.25
 2003/03/13 08:49:10 0.000 0.28
 2003/03/13 08:49:15 0.000 0.24
 2003/03/13 08:49:20 0.000 0.27
 2003/03/13 08:49:25 0.000 0.28
 2003/03/13 08:49:30 0.000 0.27
 2003/03/13 08:49:35 0.000 0.24
 2003/03/13 08:49:40 0.000 0.29
 2003/03/13 08:49:45 0.000 0.26
 2003/03/13 08:49:50 0.000 0.24
 2003/03/13 08:49:55 0.000 0.28
 2003/03/13 08:50:00 0.000 0.24
 2003/03/13 08:50:05 0.000 0.25
 2003/03/13 08:50:10 0.000 0.25
 2003/03/13 08:50:15 0.000 0.27
 2003/03/13 08:50:20 0.000 0.25
 2003/03/13 08:50:25 0.000 0.17
 2003/03/13 08:50:30 0.000 0.14
 2003/03/13 08:50:35 0.000 0.12
 2003/03/13 08:50:40 0.000 0.07
 2003/03/13 08:50:45 0.000 0.03
 2003/03/13 08:50:50 0.000 0.08
 2003/03/13 08:50:55 0.000 0.02
 2003/03/13 08:51:00 0.000 -0.01
 2003/03/13 08:51:05 0.000 0.08
 2003/03/13 08:51:10 0.000 0.08
 2003/03/13 08:51:15 0.000 0.10
 2003/03/13 08:51:20 0.000 0.09
 2003/03/13 08:51:25 0.000 0.08
 2003/03/13 08:51:30 0.000 0.07
 2003/03/13 08:51:35 0.000 0.03
 2003/03/13 08:51:40 0.000 0.05
 2003/03/13 08:51:45 0.000 0.04
 2003/03/13 08:51:50 0.000 0.02
 2003/03/13 08:51:55 0.000 0.00
 2003/03/13 08:52:00 0.000 0.03
 2003/03/13 08:52:05 0.000 0.02
 2003/03/13 08:52:10 0.000 -0.02
 2003/03/13 08:52:15 0.000 0.03
 2003/03/13 08:52:20 0.000 -0.02
 2003/03/13 08:52:25 0.000 0.01
 2003/03/13 08:52:30 0.000 0.00
 2003/03/13 08:52:35 0.000 0.00
 2003/03/13 08:52:40 0.000 0.00
 2003/03/13 08:52:45 0.000 -0.02
 2003/03/13 08:52:50 0.000 0.01

0.16

08:41:45-08:52:50

0.24

08:41:45-08:52:50

2003/03/13	06:52:55	0.000	0.00
2003/03/13	06:53:00	0.000	0.01
2003/03/13	06:53:05	0.000	0.01
2003/03/13	06:53:10	0.000	0.03
2003/03/13	06:53:15	0.000	0.02
2003/03/13	06:53:20	0.000	0.06
2003/03/13	06:53:25	0.000	0.06
2003/03/13	06:53:30	0.000	0.02
2003/03/13	06:53:35	0.000	0.04
2003/03/13	06:53:40	0.000	0.07
2003/03/13	06:53:45	0.000	0.05
2003/03/13	06:53:50	0.000	0.08
2003/03/13	06:53:55	0.000	0.05
2003/03/13	06:54:00	0.000	0.09
2003/03/13	06:54:05	0.000	0.09
2003/03/13	06:54:10	0.000	0.08
2003/03/13	06:54:15	0.000	0.11
2003/03/13	06:54:20	0.000	0.12
2003/03/13	06:54:25	0.000	0.11
2003/03/13	06:54:30	0.000	0.09
2003/03/13	06:54:35	0.000	0.13
2003/03/13	06:54:40	0.000	0.10
2003/03/13	06:54:45	0.000	0.10
2003/03/13	06:54:50	0.000	0.13
2003/03/13	06:54:55	0.000	0.10
2003/03/13	06:55:00	0.000	0.12
2003/03/13	06:55:05	0.000	0.10
2003/03/13	06:55:10	0.000	0.13
2003/03/13	06:55:15	0.000	0.14
2003/03/13	06:55:20	0.000	0.12
2003/03/13	06:55:25	0.000	0.14
2003/03/13	06:55:30	0.000	0.16
2003/03/13	06:55:35	0.000	0.14
2003/03/13	06:55:40	0.000	0.12
2003/03/13	06:55:45	0.000	0.17
2003/03/13	06:55:50	0.000	0.14
2003/03/13	06:55:55	0.000	0.13
2003/03/13	06:56:00	0.000	0.16
2003/03/13	06:56:05	0.000	0.13
2003/03/13	06:56:10	0.000	0.15
2003/03/13	06:56:15	0.000	0.14
2003/03/13	06:56:20	0.000	0.15
2003/03/13	06:56:25	0.000	0.17
2003/03/13	06:56:30	0.000	0.14
2003/03/13	06:56:35	0.000	0.15
2003/03/13	06:56:40	0.000	0.13
2003/03/13	06:56:45	0.000	0.16
2003/03/13	06:56:50	0.000	0.16
2003/03/13	06:56:55	0.000	0.20
2003/03/13	06:57:00	0.000	0.19
2003/03/13	06:57:05	0.000	0.16
2003/03/13	06:57:10	0.000	0.20
2003/03/13	06:57:15	0.000	0.16
2003/03/13	06:57:20	0.000	0.19
2003/03/13	06:57:25	0.000	0.18
2003/03/13	06:57:30	0.000	0.19
2003/03/13	06:57:35	0.000	0.20
2003/03/13	06:57:40	0.000	0.18
2003/03/13	06:57:45	0.000	0.22
2003/03/13	06:57:50	0.000	0.22
2003/03/13	06:57:55	0.000	0.22
2003/03/13	06:58:00	0.000	0.21
2003/03/13	06:58:05	0.000	0.25
2003/03/13	06:58:10	0.000	0.26
2003/03/13	06:58:15	0.000	0.21
2003/03/13	06:58:20	0.000	0.28
2003/03/13	06:58:25	0.000	0.24
2003/03/13	06:58:30	0.000	0.24
2003/03/13	06:58:35	0.000	0.24
2003/03/13	06:58:40	0.000	0.23
2003/03/13	06:58:45	0.000	0.25
2003/03/13	06:58:50	0.000	0.22
2003/03/13	06:58:55	0.000	0.28
2003/03/13	06:59:00	0.000	0.25
2003/03/13	06:59:05	0.000	0.25
2003/03/13	06:59:10	0.000	0.28
2003/03/13	06:59:15	0.000	0.28
2003/03/13	06:59:20	0.000	0.27
2003/03/13	06:59:25	0.000	0.24
2003/03/13	06:59:30	0.000	0.29
2003/03/13	06:59:35	0.000	0.25
2003/03/13	06:59:40	0.000	0.28
2003/03/13	06:59:45	0.000	0.27
2003/03/13	06:59:50	0.000	0.28
2003/03/13	06:59:55	0.000	0.28
2003/03/13	07:00:00	0.000	0.25
2003/03/13	07:00:05	0.000	0.29
2003/03/13	07:00:10	0.000	0.29
2003/03/13	07:00:15	0.000	0.27
2003/03/13	07:00:20	0.000	0.30
2003/03/13	07:00:25	0.000	0.31
2003/03/13	07:00:30	0.000	0.30
2003/03/13	07:00:35	0.000	0.28
2003/03/13	07:00:40	0.000	0.33
2003/03/13	07:00:45	0.000	0.31
2003/03/13	07:00:50	0.000	0.31
2003/03/13	07:00:55	0.000	0.34
2003/03/13	07:01:00	0.000	0.31
2003/03/13	07:01:05	0.000	0.34
2003/03/13	07:01:10	0.000	0.32
2003/03/13	07:01:15	0.000	0.36
2003/03/13	07:01:20	0.000	0.36
2003/03/13	07:01:25	0.000	0.34
2003/03/13	07:01:30	0.000	0.37
2003/03/13	07:01:35	0.000	0.39
2003/03/13	07:01:40	0.000	0.36
2003/03/13	07:01:45	0.000	0.35
2003/03/13	07:01:50	0.000	0.40
2003/03/13	07:01:55	0.000	0.37
2003/03/13	07:02:00	0.000	0.38
2003/03/13	07:02:05	0.000	0.40
2003/03/13	07:02:10	0.000	0.36
2003/03/13	07:02:15	0.000	0.39
2003/03/13	07:02:20	0.000	0.37
2003/03/13	07:02:25	0.000	0.40
2003/03/13	07:02:30	0.000	0.40
2003/03/13	07:02:35	0.000	0.38
2003/03/13	07:02:40	0.000	0.41
2003/03/13	07:02:45	0.000	0.43
2003/03/13	07:02:50	0.000	0.42
2003/03/13	07:02:55	0.000	0.41
2003/03/13	07:03:00	0.000	0.45
2003/03/13	07:03:05	0.000	0.44
2003/03/13	07:03:10	0.000	0.40
2003/03/13	07:03:15	0.000	0.45
2003/03/13	07:03:20	0.000	0.41
2003/03/13	07:03:25	0.000	0.43
2003/03/13	07:03:30	0.000	0.43
2003/03/13	07:03:35	0.000	0.43
2003/03/13	07:03:40	0.000	0.44
2003/03/13	07:03:45	0.000	0.42
2003/03/13	07:03:50	0.000	0.45
2003/03/13	07:03:55	0.000	0.44
2003/03/13	07:04:00	0.000	0.44

0.07

RESERVED FOR FUTURE USE

0.20

RESERVED FOR FUTURE USE

2003/03/13	07:04:05	0.000	0.43
2003/03/13	07:04:10	0.000	0.47
2003/03/13	07:04:15	0.000	0.45
2003/03/13	07:04:20	0.000	0.41
2003/03/13	07:04:25	0.000	0.46
2003/03/13	07:04:30	0.000	0.42
2003/03/13	07:04:35	0.000	0.44
2003/03/13	07:04:40	0.000	0.44
2003/03/13	07:04:45	0.000	0.43
2003/03/13	07:04:50	0.000	0.45
2003/03/13	07:04:55	0.000	0.43
2003/03/13	07:05:00	0.000	0.47
2003/03/13	07:05:05	0.000	0.46
2003/03/13	07:05:10	0.000	0.46
2003/03/13	07:05:15	0.000	0.47
2003/03/13	07:05:20	0.000	0.49
2003/03/13	07:05:25	0.000	0.48
2003/03/13	07:05:30	0.000	0.44
2003/03/13	07:05:35	0.000	0.50
2003/03/13	07:05:40	0.000	0.46
2003/03/13	07:05:45	0.000	0.47
2003/03/13	07:05:50	0.000	0.49
2003/03/13	07:05:55	0.000	0.48
2003/03/13	07:06:00	0.000	0.50
2003/03/13	07:06:05	0.000	0.47
2003/03/13	07:06:10	0.000	0.50
2003/03/13	07:06:15	0.000	0.50
2003/03/13	07:06:20	0.000	0.49
2003/03/13	07:06:25	0.000	0.52
2003/03/13	07:06:30	0.000	0.52
2003/03/13	07:06:35	0.000	0.51
2003/03/13	07:06:40	0.000	0.49
2003/03/13	07:06:45	0.000	0.54
2003/03/13	07:06:50	0.000	0.51
2003/03/13	07:06:55	0.000	0.54
2003/03/13	07:07:00	0.000	0.54
2003/03/13	07:07:05	0.000	0.51
2003/03/13	07:07:10	0.000	0.54
2003/03/13	07:07:15	0.000	0.51
2003/03/13	07:07:20	0.000	0.52
2003/03/13	07:07:25	0.000	0.53
2003/03/13	07:07:30	0.000	0.52
2003/03/13	07:07:35	0.000	0.54
2003/03/13	07:07:40	0.000	0.50
2003/03/13	07:07:45	0.000	0.49
2003/03/13	07:07:50	0.000	0.57
2003/03/13	07:07:55	0.000	0.25
2003/03/13	07:08:00	0.000	0.18
2003/03/13	07:08:05	0.000	0.10
2003/03/13	07:08:10	0.000	0.10
2003/03/13	07:08:15	0.000	0.04
2003/03/13	07:08:20	0.000	0.04
2003/03/13	07:08:25	0.000	0.01
2003/03/13	07:08:30	0.000	0.01
2003/03/13	07:08:35	0.000	0.03
2003/03/13	07:08:40	0.000	0.06
2003/03/13	07:08:45	0.000	0.17
2003/03/13	07:08:50	0.000	0.28
2003/03/13	07:08:55	0.000	0.35
2003/03/13	07:09:00	0.000	0.39
2003/03/13	07:09:05	0.000	0.47
2003/03/13	07:09:10	0.000	0.46
2003/03/13	07:09:15	0.000	0.46
2003/03/13	07:09:20	0.000	0.51
2003/03/13	07:09:25	0.000	0.41
2003/03/13	07:09:30	0.000	0.34
2003/03/13	07:09:35	0.000	0.28
2003/03/13	07:09:40	0.000	0.19
2003/03/13	07:09:45	0.000	0.15
2003/03/13	07:09:50	0.000	0.08
2003/03/13	07:09:55	0.000	0.08
2003/03/13	07:10:00	0.000	0.05
2003/03/13	07:10:05	0.000	0.04
2003/03/13	07:10:10	0.000	0.02
2003/03/13	07:10:15	0.000	0.04
2003/03/13	07:10:20	0.000	0.02
2003/03/13	07:10:25	0.000	-0.02
2003/03/13	07:10:30	0.000	0.03
2003/03/13	07:10:35	0.000	-0.01
2003/03/13	07:10:40	0.000	0.00
2003/03/13	07:10:45	0.000	0.01
2003/03/13	07:10:50	0.000	-0.01
2003/03/13	07:10:55	0.000	0.00
2003/03/13	07:11:00	0.000	-0.02
2003/03/13	07:11:05	0.000	0.01
2003/03/13	07:11:10	0.000	0.00
2003/03/13	07:11:15	0.000	0.00
2003/03/13	07:11:20	0.000	0.02
2003/03/13	07:11:25	0.000	0.03
2003/03/13	07:11:30	0.000	0.01
2003/03/13	07:11:35	0.000	-0.02
2003/03/13	07:11:40	0.000	0.03
2003/03/13	07:11:45	0.000	-0.01
2003/03/13	07:11:50	0.000	0.00
2003/03/13	07:11:55	0.000	0.01
2003/03/13	07:12:00	0.000	-0.01
2003/03/13	07:12:05	0.000	0.01
2003/03/13	07:12:10	0.000	-0.02
2003/03/13	07:12:15	0.000	0.01
2003/03/13	07:12:20	0.000	0.01
2003/03/13	07:12:25	0.000	0.01
2003/03/13	07:12:30	0.000	0.04
2003/03/13	07:12:35	0.000	0.05
2003/03/13	07:12:40	0.000	0.04
2003/03/13	07:12:45	0.000	0.02
2003/03/13	07:12:50	0.000	0.08
2003/03/13	07:12:55	0.000	0.05
2003/03/13	07:13:00	0.000	0.04
2003/03/13	07:13:05	0.000	0.08
2003/03/13	07:13:10	0.000	0.04
2003/03/13	07:13:15	0.000	0.07
2003/03/13	07:13:20	0.000	0.06
2003/03/13	07:13:25	0.000	0.07
2003/03/13	07:13:30	0.000	0.06
2003/03/13	07:13:35	0.000	0.06
2003/03/13	07:13:40	0.000	0.05
2003/03/13	07:13:45	0.000	0.10
2003/03/13	07:13:50	0.000	0.08
2003/03/13	07:13:55	0.000	0.06
2003/03/13	07:14:00	0.000	0.11
2003/03/13	07:14:05	0.000	0.08
2003/03/13	07:14:10	0.000	0.06
2003/03/13	07:14:15	0.000	0.10
2003/03/13	07:14:20	0.000	0.06
2003/03/13	07:14:25	0.000	0.08
2003/03/13	07:14:30	0.000	0.07
2003/03/13	07:14:35	0.000	0.08
2003/03/13	07:14:40	0.000	0.10
2003/03/13	07:14:45	0.000	0.06
2003/03/13	07:14:50	0.000	0.09
2003/03/13	07:14:55	0.000	0.10
2003/03/13	07:15:00	0.000	0.09
2003/03/13	07:15:05	0.000	0.08
2003/03/13	07:15:10	0.000	0.11

0.38

0.38

0.38

0.38

0.04

0.04

2003/03/13	07:15:15	0.000	0.10
2003/03/13	07:15:20	0.000	0.08
2003/03/13	07:15:25	0.000	0.11
2003/03/13	07:15:30	0.000	0.08
2003/03/13	07:15:35	0.000	0.08
2003/03/13	07:15:40	0.000	0.08
2003/03/13	07:15:45	0.000	0.08
2003/03/13	07:15:50	0.000	0.10
2003/03/13	07:15:55	0.000	0.08
2003/03/13	07:16:00	0.000	0.11
2003/03/13	07:16:05	0.000	0.10
2003/03/13	07:16:10	0.000	0.10
2003/03/13	07:16:15	0.000	0.10
2003/03/13	07:16:20	0.000	0.12
2003/03/13	07:16:25	0.000	0.11
2003/03/13	07:16:30	0.000	0.07
2003/03/13	07:16:35	0.000	0.13
2003/03/13	07:16:40	0.000	0.09
2003/03/13	07:16:45	0.000	0.10
2003/03/13	07:16:50	0.000	0.11
2003/03/13	07:16:55	0.000	0.09
2003/03/13	07:17:00	0.000	0.10
2003/03/13	07:17:05	0.000	0.08
2003/03/13	07:17:10	0.000	0.11
2003/03/13	07:17:15	0.000	0.11
2003/03/13	07:17:20	0.000	0.10
2003/03/13	07:17:25	0.000	0.13
2003/03/13	07:17:30	0.000	0.13
2003/03/13	07:17:35	0.000	0.12
2003/03/13	07:17:40	0.000	0.09
2003/03/13	07:17:45	0.000	0.14
2003/03/13	07:17:50	0.000	0.11
2003/03/13	07:17:55	0.000	0.10
2003/03/13	07:18:00	0.000	0.13
2003/03/13	07:18:05	0.000	0.11
2003/03/13	07:18:10	0.000	0.13
2003/03/13	07:18:15	0.000	0.11
2003/03/13	07:18:20	0.000	0.13
2003/03/13	07:18:25	0.000	0.13
2003/03/13	07:18:30	0.000	0.12
2003/03/13	07:18:35	0.000	0.16
2003/03/13	07:18:40	0.000	0.18
2003/03/13	07:18:45	0.000	0.14
2003/03/13	07:18:50	0.000	0.12
2003/03/13	07:18:55	0.000	0.17
2003/03/13	07:19:00	0.000	0.16
2003/03/13	07:19:05	0.000	0.13
2003/03/13	07:19:10	0.000	0.17
2003/03/13	07:19:15	0.000	0.13
2003/03/13	07:19:20	0.000	0.18
2003/03/13	07:19:25	0.000	0.14
2003/03/13	07:19:30	0.000	0.16
2003/03/13	07:19:35	0.000	0.17
2003/03/13	07:19:40	0.000	0.14
2003/03/13	07:19:45	0.000	0.16
2003/03/13	07:19:50	0.000	0.18
2003/03/13	07:19:55	0.000	0.17
2003/03/13	07:20:00	0.000	0.16
2003/03/13	07:20:05	0.000	0.19
2003/03/13	07:20:10	0.000	0.17
2003/03/13	07:20:15	0.000	0.16
2003/03/13	07:20:20	0.000	0.20
2003/03/13	07:20:25	0.000	0.16
2003/03/13	07:20:30	0.000	0.18
2003/03/13	07:20:35	0.000	0.17
2003/03/13	07:20:40	0.000	0.18
2003/03/13	07:20:45	0.000	0.20
2003/03/13	07:20:50	0.000	0.17
2003/03/13	07:20:55	0.000	0.19
2003/03/13	07:21:00	0.000	0.19
2003/03/13	07:21:05	0.000	0.19
2003/03/13	07:21:10	0.000	0.19
2003/03/13	07:21:15	0.000	0.21
2003/03/13	07:21:20	0.000	0.21
2003/03/13	07:21:25	0.000	0.17
2003/03/13	07:21:30	0.000	0.22
2003/03/13	07:21:35	0.000	0.17
2003/03/13	07:21:40	0.000	0.19
2003/03/13	07:21:45	0.000	0.19
2003/03/13	07:21:50	0.000	0.19
2003/03/13	07:21:55	0.000	0.21
2003/03/13	07:22:00	0.000	0.18
2003/03/13	07:22:05	0.000	0.22
2003/03/13	07:22:10	0.000	0.21
2003/03/13	07:22:15	0.000	0.21
2003/03/13	07:22:20	0.000	0.22
2003/03/13	07:22:25	0.000	0.24
2003/03/13	07:22:30	0.000	0.23
2003/03/13	07:22:35	0.000	0.20
2003/03/13	07:22:40	0.000	0.26
2003/03/13	07:22:45	0.000	0.21
2003/03/13	07:22:50	0.000	0.22
2003/03/13	07:22:55	0.000	0.24
2003/03/13	07:23:00	0.000	0.22
2003/03/13	07:23:05	0.000	0.23
2003/03/13	07:23:10	0.000	0.21
2003/03/13	07:23:15	0.000	0.25
2003/03/13	07:23:20	0.000	0.24
2003/03/13	07:23:25	0.000	0.23
2003/03/13	07:23:30	0.000	0.28
2003/03/13	07:23:35	0.000	0.27
2003/03/13	07:23:40	0.000	0.26
2003/03/13	07:23:45	0.000	0.22
2003/03/13	07:23:50	0.000	0.28
2003/03/13	07:23:55	0.000	0.26
2003/03/13	07:24:00	0.000	0.24
2003/03/13	07:24:05	0.000	0.27
2003/03/13	07:24:10	0.000	0.24
2003/03/13	07:24:15	0.000	0.27
2003/03/13	07:24:20	0.000	0.26
2003/03/13	07:24:25	0.000	0.27
2003/03/13	07:24:30	0.000	0.27
2003/03/13	07:24:35	0.000	0.28
2003/03/13	07:24:40	0.000	0.29
2003/03/13	07:24:45	0.000	0.30
2003/03/13	07:24:50	0.000	0.28
2003/03/13	07:24:55	0.000	0.28
2003/03/13	07:25:00	0.000	0.31
2003/03/13	07:25:05	0.000	0.28
2003/03/13	07:25:10	0.000	0.28
2003/03/13	07:25:15	0.000	0.31
2003/03/13	07:25:20	0.000	0.27
2003/03/13	07:25:25	0.000	0.30
2003/03/13	07:25:30	0.000	0.29
2003/03/13	07:25:35	0.000	0.30
2003/03/13	07:25:40	0.000	0.33
2003/03/13	07:25:45	0.000	0.30
2003/03/13	07:25:50	0.000	0.33
2003/03/13	07:25:55	0.000	0.33
2003/03/13	07:26:00	0.000	0.33
2003/03/13	07:26:05	0.000	0.31
2003/03/13	07:26:10	0.000	0.34
2003/03/13	07:26:15	0.000	0.32
2003/03/13	07:26:20	0.000	0.30

0.12

2003/03/13 07:26:25

0.22

2003/03/13 07:26:30

2003/03/13 07:28:25 0.000 0.34
2003/03/13 07:28:30 0.000 0.29
2003/03/13 07:28:35 0.000 0.31
2003/03/13 07:28:40 0.000 0.31
2003/03/13 07:28:45 0.000 0.27
2003/03/13 07:28:50 0.000 0.24
2003/03/13 07:28:55 0.000 0.18
2003/03/13 07:27:00 0.000 0.13
2003/03/13 07:27:05 0.000 0.09
2003/03/13 07:27:10 0.000 0.08
2003/03/13 07:27:15 0.000 0.04
2003/03/13 07:27:20 0.000 0.05
2003/03/13 07:27:25 0.000 0.03
2003/03/13 07:27:30 0.000 0.01
2003/03/13 07:27:35 0.000 0.10
2003/03/13 07:27:40 0.000 0.10
2003/03/13 07:27:45 0.000 0.11
2003/03/13 07:27:50 0.000 0.09
2003/03/13 07:27:55 0.000 0.05
2003/03/13 07:28:00 0.000 0.05
2003/03/13 07:28:05 0.000 0.01
2003/03/13 07:28:10 0.000 0.05
2003/03/13 07:28:15 0.000 0.01
2003/03/13 07:28:20 0.000 0.00
2003/03/13 07:28:25 0.000 0.01
2003/03/13 07:28:30 0.000 0.03
2003/03/13 07:28:35 0.000 0.01
2003/03/13 07:28:40 0.000 -0.02
2003/03/13 07:28:45 0.000 0.03
2003/03/13 07:28:50 0.000 0.00
2003/03/13 07:28:55 0.000 -0.01
2003/03/13 07:29:00 0.000 0.02
2003/03/13 07:29:05 0.000 -0.01
2003/03/13 07:29:10 0.000 0.00
2003/03/13 07:29:15 0.000 -0.01
2003/03/13 07:29:20 0.000 0.01
2003/03/13 07:29:25 0.000 0.01
2003/03/13 07:29:30 0.000 -0.01
2003/03/13 07:29:35 0.000 0.02
2003/03/13 07:29:40 0.000 0.04
2003/03/13 07:29:45 0.000 0.03
2003/03/13 07:29:50 0.000 0.02
2003/03/13 07:29:55 0.000 0.07
2003/03/13 07:30:00 0.000 0.05
2003/03/13 07:30:05 0.000 0.03
2003/03/13 07:30:10 0.000 0.08
2003/03/13 07:30:15 0.000 0.05
2003/03/13 07:30:20 0.000 0.08
2003/03/13 07:30:25 0.000 0.06
2003/03/13 07:30:30 0.000 0.06
2003/03/13 07:30:35 0.000 0.09
2003/03/13 07:30:40 0.000 0.08
2003/03/13 07:30:45 0.000 0.12
2003/03/13 07:30:50 0.000 0.12
2003/03/13 07:30:55 0.000 0.11
2003/03/13 07:31:00 0.000 0.11
2003/03/13 07:31:05 0.000 0.18
2003/03/13 07:31:10 0.000 0.13
2003/03/13 07:31:15 0.000 0.10
2003/03/13 07:31:20 0.000 0.15
2003/03/13 07:31:25 0.000 0.11
2003/03/13 07:31:30 0.000 0.13
2003/03/13 07:31:35 0.000 0.15
2003/03/13 07:31:40 0.000 0.13
2003/03/13 07:31:45 0.000 0.15
2003/03/13 07:31:50 0.000 0.12
2003/03/13 07:31:55 0.000 0.14
2003/03/13 07:32:00 0.000 0.15
2003/03/13 07:32:05 0.000 0.14
2003/03/13 07:32:10 0.000 0.14
2003/03/13 07:32:15 0.000 0.17
2003/03/13 07:32:20 0.000 0.18
2003/03/13 07:32:25 0.000 0.13
2003/03/13 07:32:30 0.000 0.18
2003/03/13 07:32:35 0.000 0.13
2003/03/13 07:32:40 0.000 0.15
2003/03/13 07:32:45 0.000 0.18
2003/03/13 07:32:50 0.000 0.14
2003/03/13 07:32:55 0.000 0.16
2003/03/13 07:33:00 0.000 0.14
2003/03/13 07:33:05 0.000 0.17
2003/03/13 07:33:10 0.000 0.17
2003/03/13 07:33:15 0.000 0.16
2003/03/13 07:33:20 0.000 0.18
2003/03/13 07:33:25 0.000 0.20
2003/03/13 07:33:30 0.000 0.19
2003/03/13 07:33:35 0.000 0.19
2003/03/13 07:33:40 0.000 0.24
2003/03/13 07:33:45 0.000 0.18
2003/03/13 07:33:50 0.000 0.18
2003/03/13 07:33:55 0.000 0.20
2003/03/13 07:34:00 0.000 0.18
2003/03/13 07:34:05 0.000 0.20
2003/03/13 07:34:10 0.000 0.19
2003/03/13 07:34:15 0.000 0.22
2003/03/13 07:34:20 0.000 0.22
2003/03/13 07:34:25 0.000 0.21
2003/03/13 07:34:30 0.000 0.23
2003/03/13 07:34:35 0.000 0.26
2003/03/13 07:34:40 0.000 0.25
2003/03/13 07:34:45 0.000 0.22
2003/03/13 07:34:50 0.000 0.27
2003/03/13 07:34:55 0.000 0.25
2003/03/13 07:35:00 0.000 0.23
2003/03/13 07:35:05 0.000 0.27
2003/03/13 07:35:10 0.000 0.24
2003/03/13 07:35:15 0.000 0.26
2003/03/13 07:35:20 0.000 0.25
2003/03/13 07:35:25 0.000 0.27
2003/03/13 07:35:30 0.000 0.28
2003/03/13 07:35:35 0.000 0.28
2003/03/13 07:35:40 0.000 0.30
2003/03/13 07:35:45 0.000 0.31
2003/03/13 07:35:50 0.000 0.31
2003/03/13 07:35:55 0.000 0.30
2003/03/13 07:36:00 0.000 0.35
2003/03/13 07:36:05 0.000 0.34
2003/03/13 07:36:10 0.000 0.31
2003/03/13 07:36:15 0.000 0.29
2003/03/13 07:36:20 0.000 0.32
2003/03/13 07:36:25 0.000 0.35
2003/03/13 07:36:30 0.000 0.35
2003/03/13 07:36:35 0.000 0.36
2003/03/13 07:36:40 0.000 0.37
2003/03/13 07:36:45 0.000 0.35
2003/03/13 07:36:50 0.000 0.38
2003/03/13 07:36:55 0.000 0.38
2003/03/13 07:37:00 0.000 0.39
2003/03/13 07:37:05 0.000 0.39
2003/03/13 07:37:10 0.000 0.41
2003/03/13 07:37:15 0.000 0.40
2003/03/13 07:37:20 0.000 0.38
2003/03/13 07:37:25 0.000 0.44
2003/03/13 07:37:30 0.000 0.40

0.14

2003/03/13 07:30:00

0.16

2003/03/13 07:35:00

2003/03/13	07:37:35	0.000	0.41
2003/03/13	07:37:40	0.000	0.43
2003/03/13	07:37:45	0.000	0.42
2003/03/13	07:37:50	0.000	0.44
2003/03/13	07:37:55	0.000	0.42
2003/03/13	07:38:00	0.000	0.46
2003/03/13	07:38:05	0.000	0.46
2003/03/13	07:38:10	0.000	0.46
2003/03/13	07:38:15	0.000	0.48
2003/03/13	07:38:20	0.000	0.49
2003/03/13	07:38:25	0.000	0.46
2003/03/13	07:38:30	0.000	0.46
2003/03/13	07:38:35	0.000	0.50
2003/03/13	07:38:40	0.000	0.47
2003/03/13	07:38:45	0.000	0.46
2003/03/13	07:38:50	0.000	0.51
2003/03/13	07:38:55	0.000	0.46
2003/03/13	07:39:00	0.000	0.51
2003/03/13	07:39:05	0.000	0.46
2003/03/13	07:39:10	0.000	0.51
2003/03/13	07:39:15	0.000	0.52
2003/03/13	07:39:20	0.000	0.51
2003/03/13	07:39:25	0.000	0.53
2003/03/13	07:39:30	0.000	0.55
2003/03/13	07:39:35	0.000	0.54
2003/03/13	07:39:40	0.000	0.51
2003/03/13	07:39:45	0.000	0.57
2003/03/13	07:39:50	0.000	0.54
2003/03/13	07:39:55	0.000	0.53
2003/03/13	07:40:00	0.000	0.57
2003/03/13	07:40:05	0.000	0.54
2003/03/13	07:40:10	0.000	0.57
2003/03/13	07:40:15	0.000	0.57
2003/03/13	07:40:20	0.000	0.59
2003/03/13	07:40:25	0.000	0.60
2003/03/13	07:40:30	0.000	0.58
2003/03/13	07:40:35	0.000	0.61
2003/03/13	07:40:40	0.000	0.54
2003/03/13	07:40:45	0.000	0.63
2003/03/13	07:40:50	0.000	0.52
2003/03/13	07:40:55	0.000	0.67
2003/03/13	07:41:00	0.000	0.66
2003/03/13	07:41:05	0.000	0.69
2003/03/13	07:41:10	0.000	0.69
2003/03/13	07:41:15	0.000	0.65
2003/03/13	07:41:20	0.000	0.69
2003/03/13	07:41:25	0.000	0.67
2003/03/13	07:41:30	0.000	0.68
2003/03/13	07:41:35	0.000	0.70
2003/03/13	07:41:40	0.000	0.67
2003/03/13	07:41:45	0.000	0.71
2003/03/13	07:41:50	0.000	0.70
2003/03/13	07:41:55	0.000	0.70
2003/03/13	07:42:00	0.000	0.70
2003/03/13	07:42:05	0.000	0.73
2003/03/13	07:42:10	0.000	0.73
2003/03/13	07:42:15	0.000	0.70
2003/03/13	07:42:20	0.000	0.76
2003/03/13	07:42:25	0.000	0.72
2003/03/13	07:42:30	0.000	0.75
2003/03/13	07:42:35	0.000	0.78
2003/03/13	07:42:40	0.000	0.78
2003/03/13	07:42:45	0.000	0.78
2003/03/13	07:42:50	0.000	0.78
2003/03/13	07:42:55	0.000	0.80
2003/03/13	07:43:00	0.000	0.80
2003/03/13	07:43:05	0.000	0.80
2003/03/13	07:43:10	0.000	0.82
2003/03/13	07:43:15	0.000	0.84
2003/03/13	07:43:20	0.000	0.83
2003/03/13	07:43:25	0.000	0.80
2003/03/13	07:43:30	0.000	0.86
2003/03/13	07:43:35	0.000	0.83
2003/03/13	07:43:40	0.000	0.84
2003/03/13	07:43:45	0.000	0.84
2003/03/13	07:43:50	0.000	0.81
2003/03/13	07:43:55	0.000	0.85
2003/03/13	07:44:00	0.000	0.83
2003/03/13	07:44:05	0.000	0.80
2003/03/13	07:44:10	0.000	0.68
2003/03/13	07:44:15	0.000	0.52
2003/03/13	07:44:20	0.000	0.42
2003/03/13	07:44:25	0.000	0.33
2003/03/13	07:44:30	0.000	0.23
2003/03/13	07:44:35	0.000	0.15
2003/03/13	07:44:40	0.000	0.16
2003/03/13	07:44:45	0.000	0.09
2003/03/13	07:44:50	0.000	0.05
2003/03/13	07:44:55	0.000	0.07
2003/03/13	07:45:00	0.000	0.02
2003/03/13	07:45:05	0.000	0.08
2003/03/13	07:45:10	0.000	0.17
2003/03/13	07:45:15	0.000	0.34
2003/03/13	07:45:20	0.000	0.48
2003/03/13	07:45:25	0.000	0.55
2003/03/13	07:45:30	0.000	0.65
2003/03/13	07:45:35	0.000	0.71
2003/03/13	07:45:40	0.000	0.72
2003/03/13	07:45:45	0.000	0.72
2003/03/13	07:45:50	0.000	0.75
2003/03/13	07:45:55	0.000	0.61
2003/03/13	07:46:00	0.000	0.45
2003/03/13	07:46:05	0.000	0.38
2003/03/13	07:46:10	0.000	0.25
2003/03/13	07:46:15	0.000	0.21
2003/03/13	07:46:20	0.000	0.15
2003/03/13	07:46:25	0.000	0.12
2003/03/13	07:46:30	0.000	0.10
2003/03/13	07:46:35	0.000	0.04
2003/03/13	07:46:40	0.000	0.05
2003/03/13	07:46:45	0.000	0.04
2003/03/13	07:46:50	0.000	0.03
2003/03/13	07:46:55	0.000	0.01
2003/03/13	07:47:00	0.000	0.04
2003/03/13	07:47:05	0.000	0.02
2003/03/13	07:47:10	0.000	-0.02
2003/03/13	07:47:15	0.000	0.03
2003/03/13	07:47:20	0.000	-0.02
2003/03/13	07:47:25	0.000	0.00
2003/03/13	07:47:30	0.000	0.00
2003/03/13	07:47:35	0.000	-0.01
2003/03/13	07:47:40	0.000	0.01
2003/03/13	07:47:45	0.000	-0.02
2003/03/13	07:47:50	0.000	0.02
2003/03/13	07:47:55	0.000	0.00
2003/03/13	07:48:00	0.000	0.00
2003/03/13	07:48:05	0.000	0.01
2003/03/13	07:48:10	0.000	0.03
2003/03/13	07:48:15	0.000	0.02
2003/03/13	07:48:20	0.000	-0.02
2003/03/13	07:48:25	0.000	0.03
2003/03/13	07:48:30	0.000	-0.01
2003/03/13	07:48:35	0.000	0.00
2003/03/13	07:48:40	0.000	0.02

0.41

0.41

0.64

0.64

2003/03/13	07:48:45	0.000	0.01
2003/03/13	07:48:50	0.000	0.03
2003/03/13	07:48:55	0.000	0.01
2003/03/13	07:49:00	0.000	0.04
2003/03/13	07:49:05	0.000	0.04
2003/03/13	07:49:10	0.000	0.04
2003/03/13	07:49:15	0.000	0.07
2003/03/13	07:49:20	0.000	0.08
2003/03/13	07:49:25	0.000	0.08
2003/03/13	07:49:30	0.000	0.04
2003/03/13	07:49:35	0.000	0.06
2003/03/13	07:49:40	0.000	0.07
2003/03/13	07:49:45	0.000	0.06
2003/03/13	07:49:50	0.000	0.09
2003/03/13	07:49:55	0.000	0.07
2003/03/13	07:50:00	0.000	0.09
2003/03/13	07:50:05	0.000	0.07
2003/03/13	07:50:10	0.000	0.09
2003/03/13	07:50:15	0.000	0.10
2003/03/13	07:50:20	0.000	0.08
2003/03/13	07:50:25	0.000	0.12
2003/03/13	07:50:30	0.000	0.12
2003/03/13	07:50:35	0.000	0.10
2003/03/13	07:50:40	0.000	0.08
2003/03/13	07:50:45	0.000	0.13
2003/03/13	07:50:50	0.000	0.11
2003/03/13	07:50:55	0.000	0.08
2003/03/13	07:51:00	0.000	0.12
2003/03/13	07:51:05	0.000	0.07
2003/03/13	07:51:10	0.000	0.10
2003/03/13	07:51:15	0.000	0.06
2003/03/13	07:51:20	0.000	0.10
2003/03/13	07:51:25	0.000	0.12
2003/03/13	07:51:30	0.000	0.09
2003/03/13	07:51:35	0.000	0.11
2003/03/13	07:51:40	0.000	0.12
2003/03/13	07:51:45	0.000	0.12
2003/03/13	07:51:50	0.000	0.11
2003/03/13	07:51:55	0.000	0.14
2003/03/13	07:52:00	0.000	0.12
2003/03/13	07:52:05	0.000	0.10
2003/03/13	07:52:10	0.000	0.15
2003/03/13	07:52:15	0.000	0.10
2003/03/13	07:52:20	0.000	0.12
2003/03/13	07:52:25	0.000	0.18
2003/03/13	07:52:30	0.000	0.12
2003/03/13	07:52:35	0.000	0.14
2003/03/13	07:52:40	0.000	0.11
2003/03/13	07:52:45	0.000	0.13
2003/03/13	07:52:50	0.000	0.13
2003/03/13	07:52:55	0.000	0.13
2003/03/13	07:53:00	0.000	0.14
2003/03/13	07:53:05	0.000	0.16
2003/03/13	07:53:10	0.000	0.15
2003/03/13	07:53:15	0.000	0.11
2003/03/13	07:53:20	0.000	0.16
2003/03/13	07:53:25	0.000	0.12
2003/03/13	07:53:30	0.000	0.13
2003/03/13	07:53:35	0.000	0.15
2003/03/13	07:53:40	0.000	0.13
2003/03/13	07:53:45	0.000	0.16
2003/03/13	07:53:50	0.000	0.13
2003/03/13	07:53:55	0.000	0.16
2003/03/13	07:54:00	0.000	0.16
2003/03/13	07:54:05	0.000	0.14
2003/03/13	07:54:10	0.000	0.16
2003/03/13	07:54:15	0.000	0.16
2003/03/13	07:54:20	0.000	0.16
2003/03/13	07:54:25	0.000	0.14
2003/03/13	07:54:30	0.000	0.19
2003/03/13	07:54:35	0.000	0.16
2003/03/13	07:54:40	0.000	0.15
2003/03/13	07:54:45	0.000	0.19
2003/03/13	07:54:50	0.000	0.19
2003/03/13	07:54:55	0.000	0.17
2003/03/13	07:55:00	0.000	0.16
2003/03/13	07:55:05	0.000	0.19
2003/03/13	07:55:10	0.000	0.19
2003/03/13	07:55:15	0.000	0.17
2003/03/13	07:55:20	0.000	0.20
2003/03/13	07:55:25	0.000	0.21
2003/03/13	07:55:30	0.000	0.19
2003/03/13	07:55:35	0.000	0.18
2003/03/13	07:55:40	0.000	0.23
2003/03/13	07:55:45	0.000	0.21
2003/03/13	07:55:50	0.000	0.18
2003/03/13	07:55:55	0.000	0.23
2003/03/13	07:56:00	0.000	0.19
2003/03/13	07:56:05	0.000	0.22
2003/03/13	07:56:10	0.000	0.22
2003/03/13	07:56:15	0.000	0.23
2003/03/13	07:56:20	0.000	0.23
2003/03/13	07:56:25	0.000	0.21
2003/03/13	07:56:30	0.000	0.25
2003/03/13	07:56:35	0.000	0.25
2003/03/13	07:56:40	0.000	0.25
2003/03/13	07:56:45	0.000	0.24
2003/03/13	07:56:50	0.000	0.28
2003/03/13	07:56:55	0.000	0.28
2003/03/13	07:57:00	0.000	0.23
2003/03/13	07:57:05	0.000	0.28
2003/03/13	07:57:10	0.000	0.23
2003/03/13	07:57:15	0.000	0.25
2003/03/13	07:57:20	0.000	0.26
2003/03/13	07:57:25	0.000	0.25
2003/03/13	07:57:30	0.000	0.27
2003/03/13	07:57:35	0.000	0.24
2003/03/13	07:57:40	0.000	0.27
2003/03/13	07:57:45	0.000	0.27
2003/03/13	07:57:50	0.000	0.26
2003/03/13	07:57:55	0.000	0.28
2003/03/13	07:58:00	0.000	0.29
2003/03/13	07:58:05	0.000	0.28
2003/03/13	07:58:10	0.000	0.25
2003/03/13	07:58:15	0.000	0.30
2003/03/13	07:58:20	0.000	0.28
2003/03/13	07:58:25	0.000	0.27
2003/03/13	07:58:30	0.000	0.29
2003/03/13	07:58:35	0.000	0.28
2003/03/13	07:58:40	0.000	0.28
2003/03/13	07:58:45	0.000	0.28
2003/03/13	07:58:50	0.000	0.28
2003/03/13	07:58:55	0.000	0.29
2003/03/13	07:59:00	0.000	0.27
2003/03/13	07:59:05	0.000	0.29
2003/03/13	07:59:10	0.000	0.30
2003/03/13	07:59:15	0.000	0.29
2003/03/13	07:59:20	0.000	0.29
2003/03/13	07:59:25	0.000	0.32
2003/03/13	07:59:30	0.000	0.29
2003/03/13	07:59:35	0.000	0.28
2003/03/13	07:59:40	0.000	0.31
2003/03/13	07:59:45	0.000	0.28
2003/03/13	07:59:50	0.000	0.30

0.14

██████████

0.13

██████████

2003/03/13 07:59:58 0.000 0.29
2003/03/13 08:00:00 0.000 0.30
2003/03/13 08:00:05 0.000 0.31
2003/03/13 08:00:10 0.000 0.29
2003/03/13 08:00:15 0.000 0.31
2003/03/13 08:00:20 0.000 0.33
2003/03/13 08:00:25 0.000 0.32
2003/03/13 08:00:30 0.000 0.30
2003/03/13 08:00:35 0.000 0.35
2003/03/13 08:00:40 0.000 0.34
2003/03/13 08:00:45 0.000 0.31
2003/03/13 08:00:50 0.000 0.35
2003/03/13 08:00:55 0.000 0.31
2003/03/13 08:01:00 0.000 0.34
2003/03/13 08:01:05 0.000 0.33
2003/03/13 08:01:10 0.000 0.34
2003/03/13 08:01:15 0.000 0.35
2003/03/13 08:01:20 0.000 0.33
2003/03/13 08:01:25 0.000 0.37
2003/03/13 08:01:30 0.000 0.37
2003/03/13 08:01:35 0.000 0.36
2003/03/13 08:01:40 0.000 0.38
2003/03/13 08:01:45 0.000 0.39
2003/03/13 08:01:50 0.000 0.38
2003/03/13 08:01:55 0.000 0.35
2003/03/13 08:02:00 0.000 0.40
2003/03/13 08:02:05 0.000 0.38
2003/03/13 08:02:10 0.000 0.37
2003/03/13 08:02:15 0.000 0.39
2003/03/13 08:02:20 0.000 0.38
2003/03/13 08:02:25 0.000 0.39
2003/03/13 08:02:30 0.000 0.38
2003/03/13 08:02:35 0.000 0.41
2003/03/13 08:02:40 0.000 0.41
2003/03/13 08:02:45 0.000 0.40
2003/03/13 08:02:50 0.000 0.42
2003/03/13 08:02:55 0.000 0.43
2003/03/13 08:03:00 0.000 0.41
2003/03/13 08:03:05 0.000 0.37
2003/03/13 08:03:10 0.000 0.39
2003/03/13 08:03:15 0.000 0.28
2003/03/13 08:03:20 0.000 0.21
2003/03/13 08:03:25 0.000 0.17
2003/03/13 08:03:30 0.000 0.10
2003/03/13 08:03:35 0.000 0.09
2003/03/13 08:03:40 0.000 0.03
2003/03/13 08:03:45 0.000 0.04
2003/03/13 08:03:50 0.000 0.03
2003/03/13 08:03:55 0.000 0.02
2003/03/13 08:04:00 0.000 0.09
2003/03/13 08:04:05 0.000 0.15
2003/03/13 08:04:10 0.000 0.15
2003/03/13 08:04:15 0.000 0.11
2003/03/13 08:04:20 0.000 0.13
2003/03/13 08:04:25 0.000 0.07
2003/03/13 08:04:30 0.000 0.03
2003/03/13 08:04:35 0.000 0.05
2003/03/13 08:04:40 0.000 0.01
2003/03/13 08:04:45 0.000 0.02
2003/03/13 08:04:50 0.000 -0.01
2003/03/13 08:04:55 0.000 0.01
2003/03/13 08:05:00 0.000 0.02
2003/03/13 08:05:05 0.000 -0.01
2003/03/13 08:05:10 0.000 0.01
2003/03/13 08:05:15 0.000 0.01
2003/03/13 08:05:20 0.000 0.01
2003/03/13 08:05:25 0.000 -0.01
2003/03/13 08:05:30 0.000 0.03
2003/03/13 08:05:35 0.000 0.01
2003/03/13 08:05:40 0.000 -0.01
2003/03/13 08:05:45 0.000 0.04
2003/03/13 08:05:50 0.000 -0.01
2003/03/13 08:05:55 0.000 0.02
2003/03/13 08:06:00 0.000 0.03
2003/03/13 08:06:05 0.000 0.03
2003/03/13 08:06:10 0.000 0.06
2003/03/13 08:06:15 0.000 0.03
2003/03/13 08:06:20 0.000 0.06
2003/03/13 08:06:25 0.000 0.07
2003/03/13 08:06:30 0.000 0.09
2003/03/13 08:06:35 0.000 0.10
2003/03/13 08:06:40 0.000 0.13
2003/03/13 08:06:45 0.000 0.13
2003/03/13 08:06:50 0.000 0.09
2003/03/13 08:06:55 0.000 0.15
2003/03/13 08:07:00 0.000 0.11
2003/03/13 08:07:05 0.000 0.13
2003/03/13 08:07:10 0.000 0.15
2003/03/13 08:07:15 0.000 0.13
2003/03/13 08:07:20 0.000 0.15
2003/03/13 08:07:25 0.000 0.13
2003/03/13 08:07:30 0.000 0.16
2003/03/13 08:07:35 0.000 0.16
2003/03/13 08:07:40 0.000 0.16
2003/03/13 08:07:45 0.000 0.17
2003/03/13 08:07:50 0.000 0.19
2003/03/13 08:07:55 0.000 0.18
2003/03/13 08:08:00 0.000 0.15
2003/03/13 08:08:05 0.000 0.21
2003/03/13 08:08:10 0.000 0.18
2003/03/13 08:08:15 0.000 0.17
2003/03/13 08:08:20 0.000 0.21
2003/03/13 08:08:25 0.000 0.18
2003/03/13 08:08:30 0.000 0.19
2003/03/13 08:08:35 0.000 0.18
2003/03/13 08:08:40 0.000 0.21
2003/03/13 08:08:45 0.000 0.21
2003/03/13 08:08:50 0.000 0.21
2003/03/13 08:08:55 0.000 0.24
2003/03/13 08:09:00 0.000 0.25
2003/03/13 08:09:05 0.000 0.23
2003/03/13 08:09:10 0.000 0.22
2003/03/13 08:09:15 0.000 0.27
2003/03/13 08:09:20 0.000 0.25
2003/03/13 08:09:25 0.000 0.23
2003/03/13 08:09:30 0.000 0.27
2003/03/13 08:09:35 0.000 0.24
2003/03/13 08:09:40 0.000 0.26
2003/03/13 08:09:45 0.000 0.25
2003/03/13 08:09:50 0.000 0.27
2003/03/13 08:09:55 0.000 0.28
2003/03/13 08:10:00 0.000 0.28
2003/03/13 08:10:05 0.000 0.30
2003/03/13 08:10:10 0.000 0.30
2003/03/13 08:10:15 0.000 0.30
2003/03/13 08:10:20 0.000 0.29
2003/03/13 08:10:25 0.000 0.33
2003/03/13 08:10:30 0.000 0.32
2003/03/13 08:10:35 0.000 0.30
2003/03/13 08:10:40 0.000 0.35
2003/03/13 08:10:45 0.000 0.31
2003/03/13 08:10:50 0.000 0.33
2003/03/13 08:10:55 0.000 0.34
2003/03/13 08:11:00 0.000 0.34

0.25

0.25

0.28

0.28

0.14

0.14

2003/03/13	08:11:05	0.000	0.37
2003/03/13	08:11:10	0.000	0.34
2003/03/13	08:11:15	0.000	0.37
2003/03/13	08:11:20	0.000	0.38
2003/03/13	08:11:25	0.000	0.38
2003/03/13	08:11:30	0.000	0.40
2003/03/13	08:11:35	0.000	0.42
2003/03/13	08:11:40	0.000	0.41
2003/03/13	08:11:45	0.000	0.39
2003/03/13	08:11:50	0.000	0.44
2003/03/13	08:11:55	0.000	0.41
2003/03/13	08:12:00	0.000	0.43
2003/03/13	08:12:05	0.000	0.46
2003/03/13	08:12:10	0.000	0.44
2003/03/13	08:12:15	0.000	0.46
2003/03/13	08:12:20	0.000	0.44
2003/03/13	08:12:25	0.000	0.47
2003/03/13	08:12:30	0.000	0.46
2003/03/13	08:12:35	0.000	0.47
2003/03/13	08:12:40	0.000	0.50
2003/03/13	08:12:45	0.000	0.52
2003/03/13	08:12:50	0.000	0.51
2003/03/13	08:12:55	0.000	0.48
2003/03/13	08:13:00	0.000	0.54
2003/03/13	08:13:05	0.000	0.51
2003/03/13	08:13:10	0.000	0.51
2003/03/13	08:13:15	0.000	0.55
2003/03/13	08:13:20	0.000	0.52
2003/03/13	08:13:25	0.000	0.54
2003/03/13	08:13:30	0.000	0.54
2003/03/13	08:13:35	0.000	0.59
2003/03/13	08:13:40	0.000	0.57
2003/03/13	08:13:45	0.000	0.55
2003/03/13	08:13:50	0.000	0.58
2003/03/13	08:13:55	0.000	0.60
2003/03/13	08:14:00	0.000	0.59
2003/03/13	08:14:05	0.000	0.58
2003/03/13	08:14:10	0.000	0.62
2003/03/13	08:14:15	0.000	0.62
2003/03/13	08:14:20	0.000	0.59
2003/03/13	08:14:25	0.000	0.64
2003/03/13	08:14:30	0.000	0.60
2003/03/13	08:14:35	0.000	0.63
2003/03/13	08:14:40	0.000	0.64
2003/03/13	08:14:45	0.000	0.65
2003/03/13	08:14:50	0.000	0.67
2003/03/13	08:14:55	0.000	0.68
2003/03/13	08:15:00	0.000	0.69
2003/03/13	08:15:05	0.000	0.69
2003/03/13	08:15:10	0.000	0.68
2003/03/13	08:15:15	0.000	0.70
2003/03/13	08:15:20	0.000	0.73
2003/03/13	08:15:25	0.000	0.72
2003/03/13	08:15:30	0.000	0.69
2003/03/13	08:15:35	0.000	0.75
2003/03/13	08:15:40	0.000	0.72
2003/03/13	08:15:45	0.000	0.74
2003/03/13	08:15:50	0.000	0.76
2003/03/13	08:15:55	0.000	0.78
2003/03/13	08:16:00	0.000	0.78
2003/03/13	08:16:05	0.000	0.77
2003/03/13	08:16:10	0.000	0.81
2003/03/13	08:16:15	0.000	0.80
2003/03/13	08:16:20	0.000	0.81
2003/03/13	08:16:25	0.000	0.84
2003/03/13	08:16:30	0.000	0.86
2003/03/13	08:16:35	0.000	0.85
2003/03/13	08:16:40	0.000	0.83
2003/03/13	08:16:45	0.000	0.90
2003/03/13	08:16:50	0.000	0.87
2003/03/13	08:16:55	0.000	0.88
2003/03/13	08:17:00	0.000	0.91
2003/03/13	08:17:05	0.000	0.89
2003/03/13	08:17:10	0.000	0.82
2003/03/13	08:17:15	0.000	0.90
2003/03/13	08:17:20	0.000	0.94
2003/03/13	08:17:25	0.000	0.85
2003/03/13	08:17:30	0.000	0.83
2003/03/13	08:17:35	0.000	0.87
2003/03/13	08:17:40	0.000	0.87
2003/03/13	08:17:45	0.000	0.96
2003/03/13	08:17:50	0.000	0.95
2003/03/13	08:17:55	0.000	1.00
2003/03/13	08:18:00	0.000	0.99
2003/03/13	08:18:05	0.000	0.99
2003/03/13	08:18:10	0.000	1.00
2003/03/13	08:18:15	0.000	0.97
2003/03/13	08:18:20	0.000	0.99
2003/03/13	08:18:25	0.000	0.98
2003/03/13	08:18:30	0.000	0.99
2003/03/13	08:18:35	0.000	1.01
2003/03/13	08:18:40	0.000	0.99
2003/03/13	08:18:45	0.000	1.02
2003/03/13	08:18:50	0.000	1.03
2003/03/13	08:18:55	0.000	1.03
2003/03/13	08:19:00	0.000	1.02
2003/03/13	08:19:05	0.000	1.06
2003/03/13	08:19:10	0.000	1.05
2003/03/13	08:19:15	0.000	1.03
2003/03/13	08:19:20	0.000	1.08
2003/03/13	08:19:25	0.000	1.04
2003/03/13	08:19:30	0.000	1.07
2003/03/13	08:19:35	0.000	1.08
2003/03/13	08:19:40	0.000	1.06
2003/03/13	08:19:45	0.000	1.11
2003/03/13	08:19:50	0.000	1.08
2003/03/13	08:19:55	0.000	1.11
2003/03/13	08:20:00	0.000	1.11
2003/03/13	08:20:05	0.000	1.12
2003/03/13	08:20:10	0.000	1.11
2003/03/13	08:20:15	0.000	1.11
2003/03/13	08:20:20	0.000	1.11
2003/03/13	08:20:25	0.000	1.07
2003/03/13	08:20:30	0.000	1.11
2003/03/13	08:20:35	0.000	0.99
2003/03/13	08:20:40	0.000	0.81
2003/03/13	08:20:45	0.000	0.47
2003/03/13	08:20:50	0.000	0.36
2003/03/13	08:20:55	0.000	0.33
2003/03/13	08:21:00	0.000	0.25
2003/03/13	08:21:05	0.000	0.21
2003/03/13	08:21:10	0.000	0.16
2003/03/13	08:21:15	0.000	0.11
2003/03/13	08:21:20	0.000	0.09
2003/03/13	08:21:25	0.000	0.08
2003/03/13	08:21:30	0.000	0.07
2003/03/13	08:21:35	0.000	0.14
2003/03/13	08:21:40	0.000	0.54
2003/03/13	08:21:45	0.000	0.70
2003/03/13	08:21:50	0.000	0.80
2003/03/13	08:21:55	0.000	0.82
2003/03/13	08:22:00	0.000	0.81
2003/03/13	08:22:05	0.000	0.86
2003/03/13	08:22:10	0.000	0.69

0.47

XXXXXXXXXXXXXXXXXXXX

0.81

XXXXXXXXXXXXXXXXXXXX

2003/03/13	08:22:16	0.000	1.04
2003/03/13	08:22:20	0.000	0.88
2003/03/13	08:22:25	0.000	0.82
2003/03/13	08:22:30	0.000	0.49
2003/03/13	08:22:35	0.000	0.44
2003/03/13	08:22:40	0.000	0.37
2003/03/13	08:22:45	0.000	0.27
2003/03/13	08:22:50	0.000	0.25
2003/03/13	08:22:55	0.000	0.18
2003/03/13	08:23:00	0.000	0.10
2003/03/13	08:23:05	0.000	0.12
2003/03/13	08:23:10	0.000	0.04
2003/03/13	08:23:15	0.000	0.05
2003/03/13	08:23:20	0.000	0.03
2003/03/13	08:23:25	0.000	0.02
2003/03/13	08:23:30	0.000	0.02
2003/03/13	08:23:35	0.000	0.00
2003/03/13	08:23:40	0.000	0.03
2003/03/13	08:23:45	0.000	0.01
2003/03/13	08:23:50	0.000	0.01
2003/03/13	08:23:55	0.000	0.01
2003/03/13	08:24:00	0.000	0.03
2003/03/13	08:24:05	0.000	0.01
2003/03/13	08:24:10	0.000	-0.02
2003/03/13	08:24:15	0.000	0.03
2003/03/13	08:24:20	0.000	-0.01
2003/03/13	08:24:25	0.000	0.00
2003/03/13	08:24:30	0.000	0.01
2003/03/13	08:24:35	0.000	-0.01
2003/03/13	08:24:40	0.000	0.01
2003/03/13	08:24:45	0.000	-0.02
2003/03/13	08:24:50	0.000	0.01
2003/03/13	08:24:55	0.000	0.01
2003/03/13	08:25:00	0.000	0.01
2003/03/13	08:25:05	0.000	0.04
2003/03/13	08:25:10	0.000	0.04
2003/03/13	08:25:15	0.000	0.03
2003/03/13	08:25:20	0.000	0.01
2003/03/13	08:25:25	0.000	0.07
2003/03/13	08:25:30	0.000	0.05
2003/03/13	08:25:35	0.000	0.04
2003/03/13	08:25:40	0.000	0.08
2003/03/13	08:25:45	0.000	0.05
2003/03/13	08:25:50	0.000	0.08
2003/03/13	08:25:55	0.000	0.07
2003/03/13	08:26:00	0.000	0.10
2003/03/13	08:26:05	0.000	0.11
2003/03/13	08:26:10	0.000	0.08
2003/03/13	08:26:15	0.000	0.12
2003/03/13	08:26:20	0.000	0.13
2003/03/13	08:26:25	0.000	0.12
2003/03/13	08:26:30	0.000	0.10
2003/03/13	08:26:35	0.000	0.15
2003/03/13	08:26:40	0.000	0.13
2003/03/13	08:26:45	0.000	0.11
2003/03/13	08:26:50	0.000	0.15
2003/03/13	08:26:55	0.000	0.11
2003/03/13	08:27:00	0.000	0.13
2003/03/13	08:27:05	0.000	0.13
2003/03/13	08:27:10	0.000	0.13
2003/03/13	08:27:15	0.000	0.15
2003/03/13	08:27:20	0.000	0.11
2003/03/13	08:27:25	0.000	0.14
2003/03/13	08:27:30	0.000	0.14
2003/03/13	08:27:35	0.000	0.14
2003/03/13	08:27:40	0.000	0.14
2003/03/13	08:27:45	0.000	0.16
2003/03/13	08:27:50	0.000	0.16
2003/03/13	08:27:55	0.000	0.12
2003/03/13	08:28:00	0.000	0.17
2003/03/13	08:28:05	0.000	0.13
2003/03/13	08:28:10	0.000	0.15
2003/03/13	08:28:15	0.000	0.16
2003/03/13	08:28:20	0.000	0.14
2003/03/13	08:28:25	0.000	0.15
2003/03/13	08:28:30	0.000	0.13
2003/03/13	08:28:35	0.000	0.16
2003/03/13	08:28:40	0.000	0.15
2003/03/13	08:28:45	0.000	0.15
2003/03/13	08:28:50	0.000	0.16
2003/03/13	08:28:55	0.000	0.17
2003/03/13	08:29:00	0.000	0.17
2003/03/13	08:29:05	0.000	0.13
2003/03/13	08:29:10	0.000	0.19
2003/03/13	08:29:15	0.000	0.15
2003/03/13	08:29:20	0.000	0.14
2003/03/13	08:29:25	0.000	0.18
2003/03/13	08:29:30	0.000	0.14
2003/03/13	08:29:35	0.000	0.16
2003/03/13	08:29:40	0.000	0.14
2003/03/13	08:29:45	0.000	0.16
2003/03/13	08:29:50	0.000	0.17
2003/03/13	08:29:55	0.000	0.15
2003/03/13	08:30:00	0.000	0.18
2003/03/13	08:30:05	0.000	0.18
2003/03/13	08:30:10	0.000	0.17
2003/03/13	08:30:15	0.000	0.16
2003/03/13	08:30:20	0.000	0.20
2003/03/13	08:30:25	0.000	0.18
2003/03/13	08:30:30	0.000	0.15
2003/03/13	08:30:35	0.000	0.19
2003/03/13	08:30:40	0.000	0.15
2003/03/13	08:30:45	0.000	0.16
2003/03/13	08:30:50	0.000	0.17
2003/03/13	08:30:55	0.000	0.18
2003/03/13	08:31:00	0.000	0.19
2003/03/13	08:31:05	0.000	0.17
2003/03/13	08:31:10	0.000	0.20
2003/03/13	08:31:15	0.000	0.21
2003/03/13	08:31:20	0.000	0.21
2003/03/13	08:31:25	0.000	0.21
2003/03/13	08:31:30	0.000	0.25
2003/03/13	08:31:35	0.000	0.24
2003/03/13	08:31:40	0.000	0.22
2003/03/13	08:31:45	0.000	0.27
2003/03/13	08:31:50	0.000	0.23
2003/03/13	08:31:55	0.000	0.25
2003/03/13	08:32:00	0.000	0.28
2003/03/13	08:32:05	0.000	0.25
2003/03/13	08:32:10	0.000	0.28
2003/03/13	08:32:15	0.000	0.25
2003/03/13	08:32:20	0.000	0.28
2003/03/13	08:32:25	0.000	0.28
2003/03/13	08:32:30	0.000	0.27
2003/03/13	08:32:35	0.000	0.29
2003/03/13	08:32:40	0.000	0.31
2003/03/13	08:32:45	0.000	0.29
2003/03/13	08:32:50	0.000	0.27
2003/03/13	08:32:55	0.000	0.33
2003/03/13	08:33:00	0.000	0.30
2003/03/13	08:33:05	0.000	0.29
2003/03/13	08:33:10	0.000	0.33
2003/03/13	08:33:15	0.000	0.30
2003/03/13	08:33:20	0.000	0.33

0.38

08/22/2003 08:22:16

0.12

08/22/2003 08:30:00

2003/03/13	08:33:25	0.000	0.31
2003/03/13	08:33:20	0.000	0.33
2003/03/13	08:33:35	0.000	0.34
2003/03/13	08:33:40	0.000	0.31
2003/03/13	08:33:45	0.000	0.34
2003/03/13	08:33:50	0.000	0.38
2003/03/13	08:33:55	0.000	0.35
2003/03/13	08:34:00	0.000	0.33
2003/03/13	08:34:05	0.000	0.38
2003/03/13	08:34:10	0.000	0.38
2003/03/13	08:34:15	0.000	0.34
2003/03/13	08:34:20	0.000	0.38
2003/03/13	08:34:25	0.000	0.34
2003/03/13	08:34:30	0.000	0.38
2003/03/13	08:34:35	0.000	0.38
2003/03/13	08:34:40	0.000	0.38
2003/03/13	08:34:45	0.000	0.38
2003/03/13	08:34:50	0.000	0.35
2003/03/13	08:34:55	0.000	0.35
2003/03/13	08:35:00	0.000	0.38
2003/03/13	08:35:05	0.000	0.38
2003/03/13	08:35:10	0.000	0.38
2003/03/13	08:35:15	0.000	0.41
2003/03/13	08:35:20	0.000	0.41
2003/03/13	08:35:25	0.000	0.37
2003/03/13	08:35:30	0.000	0.42
2003/03/13	08:35:35	0.000	0.38
2003/03/13	08:35:40	0.000	0.40
2003/03/13	08:35:45	0.000	0.41
2003/03/13	08:35:50	0.000	0.39
2003/03/13	08:35:55	0.000	0.41
2003/03/13	08:36:00	0.000	0.39
2003/03/13	08:36:05	0.000	0.42
2003/03/13	08:36:10	0.000	0.42
2003/03/13	08:36:15	0.000	0.41
2003/03/13	08:36:20	0.000	0.42
2003/03/13	08:36:25	0.000	0.44
2003/03/13	08:36:30	0.000	0.43
2003/03/13	08:36:35	0.000	0.40
2003/03/13	08:36:40	0.000	0.46
2003/03/13	08:36:45	0.000	0.43
2003/03/13	08:36:50	0.000	0.42
2003/03/13	08:36:55	0.000	0.45
2003/03/13	08:37:00	0.000	0.43
2003/03/13	08:37:05	0.000	0.44
2003/03/13	08:37:10	0.000	0.43
2003/03/13	08:37:15	0.000	0.45
2003/03/13	08:37:20	0.000	0.46
2003/03/13	08:37:25	0.000	0.45
2003/03/13	08:37:30	0.000	0.46
2003/03/13	08:37:35	0.000	0.49
2003/03/13	08:37:40	0.000	0.48
2003/03/13	08:37:45	0.000	0.46
2003/03/13	08:37:50	0.000	0.51
2003/03/13	08:37:55	0.000	0.50
2003/03/13	08:38:00	0.000	0.47
2003/03/13	08:38:05	0.000	0.52
2003/03/13	08:38:10	0.000	0.46
2003/03/13	08:38:15	0.000	0.50
2003/03/13	08:38:20	0.000	0.49
2003/03/13	08:38:25	0.000	0.51
2003/03/13	08:38:30	0.000	0.53
2003/03/13	08:38:35	0.000	0.55
2003/03/13	08:38:40	0.000	0.59
2003/03/13	08:38:45	0.000	0.59
2003/03/13	08:38:50	0.000	0.58
2003/03/13	08:38:55	0.000	0.58
2003/03/13	08:39:00	0.000	0.60
2003/03/13	08:39:05	0.000	0.58
2003/03/13	08:39:10	0.000	0.54
2003/03/13	08:39:15	0.000	0.59
2003/03/13	08:39:20	0.000	0.54
2003/03/13	08:39:25	0.000	0.59
2003/03/13	08:39:30	0.000	0.57
2003/03/13	08:39:35	0.000	0.58
2003/03/13	08:39:40	0.000	0.59
2003/03/13	08:39:45	0.000	0.49
2003/03/13	08:39:50	0.000	0.41
2003/03/13	08:39:55	0.000	0.32
2003/03/13	08:40:00	0.000	0.23
2003/03/13	08:40:05	0.000	0.19
2003/03/13	08:40:10	0.000	0.16
2003/03/13	08:40:15	0.000	0.10
2003/03/13	08:40:20	0.000	0.05
2003/03/13	08:40:25	0.000	0.11
2003/03/13	08:40:30	0.000	0.14
2003/03/13	08:40:35	0.000	0.20
2003/03/13	08:40:40	0.000	0.24
2003/03/13	08:40:45	0.000	0.16
2003/03/13	08:40:50	0.000	0.15
2003/03/13	08:40:55	0.000	0.09
2003/03/13	08:41:00	0.000	0.08
2003/03/13	08:41:05	0.000	0.07
2003/03/13	08:41:10	0.000	0.03
2003/03/13	08:41:15	0.000	0.04
2003/03/13	08:41:20	0.000	0.04
2003/03/13	08:41:25	0.000	0.02
2003/03/13	08:41:30	0.000	-0.01
2003/03/13	08:41:35	0.000	0.04
2003/03/13	08:41:40	0.000	0.02
2003/03/13	08:41:45	0.000	-0.01
2003/03/13	08:41:50	0.000	0.04
2003/03/13	08:41:55	0.000	-0.01
2003/03/13	08:42:00	0.000	0.02
2003/03/13	08:42:05	0.000	0.01
2003/03/13	08:42:10	0.000	0.02
2003/03/13	08:42:15	0.000	0.04
2003/03/13	08:42:20	0.000	0.01
2003/03/13	08:42:25	0.000	0.04
2003/03/13	08:42:30	0.000	0.04
2003/03/13	08:42:35	0.000	0.05
2003/03/13	08:42:40	0.000	0.05
2003/03/13	08:42:45	0.000	0.09
2003/03/13	08:42:50	0.000	0.09
2003/03/13	08:42:55	0.000	0.07
2003/03/13	08:43:00	0.000	0.12
2003/03/13	08:43:05	0.000	0.09
2003/03/13	08:43:10	0.000	0.12
2003/03/13	08:43:15	0.000	0.13
2003/03/13	08:43:20	0.000	0.12
2003/03/13	08:43:25	0.000	0.15
2003/03/13	08:43:30	0.000	0.13
2003/03/13	08:43:35	0.000	0.17
2003/03/13	08:43:40	0.000	0.16
2003/03/13	08:43:45	0.000	0.16
2003/03/13	08:43:50	0.000	0.16
2003/03/13	08:43:55	0.000	0.20
2003/03/13	08:44:00	0.000	0.19
2003/03/13	08:44:05	0.000	0.16
2003/03/13	08:44:10	0.000	0.22
2003/03/13	08:44:15	0.000	0.19
2003/03/13	08:44:20	0.000	0.19
2003/03/13	08:44:25	0.000	0.22
2003/03/13	08:44:30	0.000	0.20

0.27

08:26:00 08:26:00

0.47

08:26:00 08:26:00

2003/03/13	08:44:35	0.000	0.21
2003/03/13	08:44:40	0.000	0.20
2003/03/13	08:44:45	0.000	0.23
2003/03/13	08:44:50	0.000	0.24
2003/03/13	08:44:55	0.000	0.23
2003/03/13	08:45:00	0.000	0.26
2003/03/13	08:45:05	0.000	0.26
2003/03/13	08:45:10	0.000	0.25
2003/03/13	08:45:15	0.000	0.23
2003/03/13	08:45:20	0.000	0.26
2003/03/13	08:45:25	0.000	0.27
2003/03/13	08:45:30	0.000	0.25
2003/03/13	08:45:35	0.000	0.29
2003/03/13	08:45:40	0.000	0.26
2003/03/13	08:45:45	0.000	0.28
2003/03/13	08:45:50	0.000	0.27
2003/03/13	08:45:55	0.000	0.29
2003/03/13	08:46:00	0.000	0.30
2003/03/13	08:46:05	0.000	0.29
2003/03/13	08:46:10	0.000	0.33
2003/03/13	08:46:15	0.000	0.33
2003/03/13	08:46:20	0.000	0.33
2003/03/13	08:46:25	0.000	0.33
2003/03/13	08:46:30	0.000	0.38
2003/03/13	08:46:35	0.000	0.38
2003/03/13	08:46:40	0.000	0.33
2003/03/13	08:46:45	0.000	0.39
2003/03/13	08:46:50	0.000	0.35
2003/03/13	08:46:55	0.000	0.37
2003/03/13	08:47:00	0.000	0.38
2003/03/13	08:47:05	0.000	0.38
2003/03/13	08:47:10	0.000	0.41
2003/03/13	08:47:15	0.000	0.38
2003/03/13	08:47:20	0.000	0.41
2003/03/13	08:47:25	0.000	0.42
2003/03/13	08:47:30	0.000	0.42
2003/03/13	08:47:35	0.000	0.45
2003/03/13	08:47:40	0.000	0.46
2003/03/13	08:47:45	0.000	0.45
2003/03/13	08:47:50	0.000	0.43
2003/03/13	08:47:55	0.000	0.49
2003/03/13	08:48:00	0.000	0.46
2003/03/13	08:48:05	0.000	0.47
2003/03/13	08:48:10	0.000	0.50
2003/03/13	08:48:15	0.000	0.48
2003/03/13	08:48:20	0.000	0.51
2003/03/13	08:48:25	0.000	0.50
2003/03/13	08:48:30	0.000	0.53
2003/03/13	08:48:35	0.000	0.55
2003/03/13	08:48:40	0.000	0.54
2003/03/13	08:48:45	0.000	0.58
2003/03/13	08:48:50	0.000	0.60
2003/03/13	08:48:55	0.000	0.59
2003/03/13	08:49:00	0.000	0.57
2003/03/13	08:49:05	0.000	0.62
2003/03/13	08:49:10	0.000	0.61
2003/03/13	08:49:15	0.000	0.59
2003/03/13	08:49:20	0.000	0.64
2003/03/13	08:49:25	0.000	0.61
2003/03/13	08:49:30	0.000	0.65
2003/03/13	08:49:35	0.000	0.66
2003/03/13	08:49:40	0.000	0.67
2003/03/13	08:49:45	0.000	0.69
2003/03/13	08:49:50	0.000	0.67
2003/03/13	08:49:55	0.000	0.70
2003/03/13	08:50:00	0.000	0.71
2003/03/13	08:50:05	0.000	0.71
2003/03/13	08:50:10	0.000	0.72
2003/03/13	08:50:15	0.000	0.75
2003/03/13	08:50:20	0.000	0.76
2003/03/13	08:50:25	0.000	0.73
2003/03/13	08:50:30	0.000	0.79
2003/03/13	08:50:35	0.000	0.78
2003/03/13	08:50:40	0.000	0.79
2003/03/13	08:50:45	0.000	0.80
2003/03/13	08:50:50	0.000	0.79
2003/03/13	08:50:55	0.000	0.81
2003/03/13	08:51:00	0.000	0.81
2003/03/13	08:51:05	0.000	0.85
2003/03/13	08:51:10	0.000	0.88
2003/03/13	08:51:15	0.000	0.85
2003/03/13	08:51:20	0.000	0.88
2003/03/13	08:51:25	0.000	0.90
2003/03/13	08:51:30	0.000	0.90
2003/03/13	08:51:35	0.000	0.88
2003/03/13	08:51:40	0.000	0.94
2003/03/13	08:51:45	0.000	0.93
2003/03/13	08:51:50	0.000	0.82
2003/03/13	08:51:55	0.000	0.86
2003/03/13	08:52:00	0.000	0.93
2003/03/13	08:52:05	0.000	0.98
2003/03/13	08:52:10	0.000	0.95
2003/03/13	08:52:15	0.000	0.97
2003/03/13	08:52:20	0.000	0.98
2003/03/13	08:52:25	0.000	0.97
2003/03/13	08:52:30	0.000	1.02
2003/03/13	08:52:35	0.000	1.04
2003/03/13	08:52:40	0.000	1.04
2003/03/13	08:52:45	0.000	1.04
2003/03/13	08:52:50	0.000	1.09
2003/03/13	08:52:55	0.000	1.09
2003/03/13	08:53:00	0.000	1.07
2003/03/13	08:53:05	0.000	1.12
2003/03/13	08:53:10	0.000	1.08
2003/03/13	08:53:15	0.000	1.12
2003/03/13	08:53:20	0.000	1.13
2003/03/13	08:53:25	0.000	1.13
2003/03/13	08:53:30	0.000	1.15
2003/03/13	08:53:35	0.000	1.14
2003/03/13	08:53:40	0.000	1.18
2003/03/13	08:53:45	0.000	1.18
2003/03/13	08:53:50	0.000	1.18
2003/03/13	08:53:55	0.000	1.20
2003/03/13	08:54:00	0.000	1.22
2003/03/13	08:54:05	0.000	1.21
2003/03/13	08:54:10	0.000	1.20
2003/03/13	08:54:15	0.000	1.25
2003/03/13	08:54:20	0.000	1.22
2003/03/13	08:54:25	0.000	1.23
2003/03/13	08:54:30	0.000	1.25
2003/03/13	08:54:35	0.000	1.24
2003/03/13	08:54:40	0.000	1.27
2003/03/13	08:54:45	0.000	1.25
2003/03/13	08:54:50	0.000	1.28
2003/03/13	08:54:55	0.000	1.29
2003/03/13	08:55:00	0.000	1.28
2003/03/13	08:55:05	0.000	1.32
2003/03/13	08:55:10	0.000	1.33
2003/03/13	08:55:15	0.000	1.32
2003/03/13	08:55:20	0.000	1.31
2003/03/13	08:55:25	0.000	1.35
2003/03/13	08:55:30	0.000	1.34
2003/03/13	08:55:35	0.000	1.33
2003/03/13	08:55:40	0.000	1.38

0.12

XXXXXXXXXXXXXXXXXXXX

0.44

XXXXXXXXXXXXXXXXXXXX

1.01

XXXXXXXXXXXXXXXXXXXX

2003/03/13	08:55:45	0.000	1.36
2003/03/13	08:56:00	0.000	1.39
2003/03/13	08:56:15	0.000	1.38
2003/03/13	08:56:30	0.000	1.39
2003/03/13	08:56:45	0.000	1.42
2003/03/13	08:57:00	0.000	1.39
2003/03/13	08:57:15	0.000	1.43
2003/03/13	08:57:30	0.000	1.44
2003/03/13	08:57:45	0.000	1.44
2003/03/13	08:58:00	0.000	1.46
2003/03/13	08:58:15	0.000	1.43
2003/03/13	08:58:30	0.000	1.40
2003/03/13	08:58:45	0.000	1.45
2003/03/13	08:59:00	0.000	1.42
2003/03/13	08:59:15	0.000	1.38
2003/03/13	08:59:30	0.000	0.97
2003/03/13	08:59:45	0.000	0.74
2003/03/13	09:00:00	0.000	0.69
2003/03/13	09:00:15	0.000	0.42
2003/03/13	09:00:30	0.000	0.34
2003/03/13	09:00:45	0.000	0.30
2003/03/13	09:01:00	0.000	0.25
2003/03/13	09:01:15	0.000	0.21
2003/03/13	09:01:30	0.000	0.18
2003/03/13	09:01:45	0.000	0.19
2003/03/13	09:02:00	0.000	0.07
2003/03/13	09:02:15	0.000	0.16
2003/03/13	09:02:30	0.000	0.65
2003/03/13	09:02:45	0.000	0.76
2003/03/13	09:03:00	0.000	0.95
2003/03/13	09:03:15	0.000	1.03
2003/03/13	09:03:30	0.000	1.16
2003/03/13	09:03:45	0.000	1.18
2003/03/13	09:04:00	0.000	1.21
2003/03/13	09:04:15	0.000	1.27
2003/03/13	09:04:30	0.000	1.22
2003/03/13	09:04:45	0.000	0.87
2003/03/13	09:05:00	0.000	0.69
2003/03/13	09:05:15	0.000	0.66
2003/03/13	09:05:30	0.000	0.60
2003/03/13	09:05:45	0.000	0.43
2003/03/13	09:06:00	0.000	0.33
2003/03/13	09:06:15	0.000	0.22
2003/03/13	09:06:30	0.000	0.20
2003/03/13	09:06:45	0.000	0.12
2003/03/13	09:07:00	0.000	0.10
2003/03/13	09:07:15	0.000	0.08
2003/03/13	09:07:30	0.000	0.05
2003/03/13	09:07:45	0.000	0.05
2003/03/13	09:08:00	0.000	0.02
2003/03/13	09:08:15	0.000	0.04
2003/03/13	09:08:30	0.000	0.03
2003/03/13	09:08:45	0.000	0.01
2003/03/13	09:09:00	0.000	0.02
2003/03/13	09:09:15	0.000	0.03
2003/03/13	09:09:30	0.000	0.02
2003/03/13	09:09:45	0.000	-0.01
2003/03/13	09:10:00	0.000	0.03
2003/03/13	09:10:15	0.000	0.00
2003/03/13	09:10:30	0.000	0.03
2003/03/13	09:10:45	0.000	0.00
2003/03/13	09:11:00	0.000	-0.01
2003/03/13	09:11:15	0.000	0.03
2003/03/13	09:11:30	0.000	0.01
2003/03/13	09:11:45	0.000	0.04
2003/03/13	09:12:00	0.000	0.02
2003/03/13	09:12:15	0.000	0.06
2003/03/13	09:12:30	0.000	0.06
2003/03/13	09:12:45	0.000	0.06
2003/03/13	09:13:00	0.000	0.05
2003/03/13	09:13:15	0.000	0.10
2003/03/13	09:13:30	0.000	0.09
2003/03/13	09:13:45	0.000	0.06
2003/03/13	09:14:00	0.000	0.11
2003/03/13	09:14:15	0.000	0.07
2003/03/13	09:14:30	0.000	0.10
2003/03/13	09:14:45	0.000	0.10
2003/03/13	09:15:00	0.000	0.09
2003/03/13	09:15:15	0.000	0.08
2003/03/13	09:15:30	0.000	0.10
2003/03/13	09:15:45	0.000	0.09
2003/03/13	09:16:00	0.000	0.12
2003/03/13	09:16:15	0.000	0.10
2003/03/13	09:16:30	0.000	0.10
2003/03/13	09:16:45	0.000	0.11
2003/03/13	09:17:00	0.000	0.12
2003/03/13	09:17:15	0.000	0.13
2003/03/13	09:17:30	0.000	0.12
2003/03/13	09:17:45	0.000	0.09
2003/03/13	09:18:00	0.000	0.15
2003/03/13	09:18:15	0.000	0.11
2003/03/13	09:18:30	0.000	0.11
2003/03/13	09:18:45	0.000	0.14
2003/03/13	09:19:00	0.000	0.14
2003/03/13	09:19:15	0.000	0.12
2003/03/13	09:19:30	0.000	0.16
2003/03/13	09:19:45	0.000	0.16
2003/03/13	09:20:00	0.000	0.15
2003/03/13	09:20:15	0.000	0.16
2003/03/13	09:20:30	0.000	0.15
2003/03/13	09:20:45	0.000	0.13
2003/03/13	09:21:00	0.000	0.18
2003/03/13	09:21:15	0.000	0.18
2003/03/13	09:21:30	0.000	0.15
2003/03/13	09:21:45	0.000	0.13
2003/03/13	09:22:00	0.000	0.18
2003/03/13	09:22:15	0.000	0.18
2003/03/13	09:22:30	0.000	0.19
2003/03/13	09:22:45	0.000	0.20
2003/03/13	09:23:00	0.000	0.19
2003/03/13	09:23:15	0.000	0.18
2003/03/13	09:23:30	0.000	0.22
2003/03/13	09:23:45	0.000	0.19
2003/03/13	09:24:00	0.000	0.22
2003/03/13	09:24:15	0.000	0.20
2003/03/13	09:24:30	0.000	0.23
2003/03/13	09:24:45	0.000	0.21
2003/03/13	09:25:00	0.000	0.24
2003/03/13	09:25:15	0.000	0.24
2003/03/13	09:25:30	0.000	0.23
2003/03/13	09:25:45	0.000	0.25
2003/03/13	09:26:00	0.000	0.26
2003/03/13	09:26:15	0.000	0.28
2003/03/13	09:26:30	0.000	0.28
2003/03/13	09:26:45	0.000	0.25
2003/03/13	09:27:00	0.000	0.23

0.67

PANDA087101020205

0.69

PANDA023101020205

2003/03/13 09:06:55 0.000 0.28
2003/03/13 09:07:00 0.000 0.28
2003/03/13 09:07:05 0.000 0.25
2003/03/13 09:07:10 0.000 0.28
2003/03/13 09:07:15 0.000 0.25
2003/03/13 09:07:20 0.000 0.28
2003/03/13 09:07:25 0.000 0.28
2003/03/13 09:07:30 0.000 0.29
2003/03/13 09:07:35 0.000 0.32
2003/03/13 09:07:40 0.000 0.28
2003/03/13 09:07:45 0.000 0.32
2003/03/13 09:07:50 0.000 0.33
2003/03/13 09:07:55 0.000 0.33
2003/03/13 09:08:00 0.000 0.33
2003/03/13 09:08:05 0.000 0.35
2003/03/13 09:08:10 0.000 0.35
2003/03/13 09:08:15 0.000 0.31
2003/03/13 09:08:20 0.000 0.37
2003/03/13 09:08:25 0.000 0.33
2003/03/13 09:08:30 0.000 0.36
2003/03/13 09:08:35 0.000 0.37
2003/03/13 09:08:40 0.000 0.34
2003/03/13 09:08:45 0.000 0.37
2003/03/13 09:08:50 0.000 0.35
2003/03/13 09:08:55 0.000 0.39
2003/03/13 09:09:00 0.000 0.39
2003/03/13 09:09:05 0.000 0.38
2003/03/13 09:09:10 0.000 0.40
2003/03/13 09:09:15 0.000 0.42
2003/03/13 09:09:20 0.000 0.41
2003/03/13 09:09:25 0.000 0.39
2003/03/13 09:09:30 0.000 0.44
2003/03/13 09:09:35 0.000 0.42
2003/03/13 09:09:40 0.000 0.40
2003/03/13 09:09:45 0.000 0.44
2003/03/13 09:09:50 0.000 0.40
2003/03/13 09:09:55 0.000 0.43
2003/03/13 09:10:00 0.000 0.42
2003/03/13 09:10:05 0.000 0.44
2003/03/13 09:10:10 0.000 0.45
2003/03/13 09:10:15 0.000 0.43
2003/03/13 09:10:20 0.000 0.48
2003/03/13 09:10:25 0.000 0.48
2003/03/13 09:10:30 0.000 0.45
2003/03/13 09:10:35 0.000 0.45
2003/03/13 09:10:40 0.000 0.48
2003/03/13 09:10:45 0.000 0.47
2003/03/13 09:10:50 0.000 0.44
2003/03/13 09:10:55 0.000 0.49
2003/03/13 09:11:00 0.000 0.45
2003/03/13 09:11:05 0.000 0.47
2003/03/13 09:11:10 0.000 0.48
2003/03/13 09:11:15 0.000 0.46
2003/03/13 09:11:20 0.000 0.48
2003/03/13 09:11:25 0.000 0.46
2003/03/13 09:11:30 0.000 0.49
2003/03/13 09:11:35 0.000 0.49
2003/03/13 09:11:40 0.000 0.47
2003/03/13 09:11:45 0.000 0.50
2003/03/13 09:11:50 0.000 0.51
2003/03/13 09:11:55 0.000 0.50
2003/03/13 09:12:00 0.000 0.48
2003/03/13 09:12:05 0.000 0.52
2003/03/13 09:12:10 0.000 0.50
2003/03/13 09:12:15 0.000 0.49
2003/03/13 09:12:20 0.000 0.53
2003/03/13 09:12:25 0.000 0.48
2003/03/13 09:12:30 0.000 0.52
2003/03/13 09:12:35 0.000 0.50
2003/03/13 09:12:40 0.000 0.51
2003/03/13 09:12:45 0.000 0.53
2003/03/13 09:12:50 0.000 0.51
2003/03/13 09:12:55 0.000 0.54
2003/03/13 09:13:00 0.000 0.55
2003/03/13 09:13:05 0.000 0.54
2003/03/13 09:13:10 0.000 0.55
2003/03/13 09:13:15 0.000 0.55
2003/03/13 09:13:20 0.000 0.57
2003/03/13 09:13:25 0.000 0.54
2003/03/13 09:13:30 0.000 0.59
2003/03/13 09:13:35 0.000 0.54
2003/03/13 09:13:40 0.000 0.57
2003/03/13 09:13:45 0.000 0.58
2003/03/13 09:13:50 0.000 0.57
2003/03/13 09:13:55 0.000 0.59
2003/03/13 09:14:00 0.000 0.57
2003/03/13 09:14:05 0.000 0.59
2003/03/13 09:14:10 0.000 0.59
2003/03/13 09:14:15 0.000 0.59
2003/03/13 09:14:20 0.000 0.61
2003/03/13 09:14:25 0.000 0.62
2003/03/13 09:14:30 0.000 0.61
2003/03/13 09:14:35 0.000 0.59
2003/03/13 09:14:40 0.000 0.54
2003/03/13 09:14:45 0.000 0.61
2003/03/13 09:14:50 0.000 0.60
2003/03/13 09:14:55 0.000 0.54
2003/03/13 09:15:00 0.000 0.63
2003/03/13 09:15:05 0.000 0.68
2003/03/13 09:15:10 0.000 0.66
2003/03/13 09:15:15 0.000 0.66
2003/03/13 09:15:20 0.000 0.69
2003/03/13 09:15:25 0.000 0.66
2003/03/13 09:15:30 0.000 0.68
2003/03/13 09:15:35 0.000 0.69
2003/03/13 09:15:40 0.000 0.68
2003/03/13 09:15:45 0.000 0.67
2003/03/13 09:15:50 0.000 0.70
2003/03/13 09:15:55 0.000 0.68
2003/03/13 09:16:00 0.000 0.67
2003/03/13 09:16:05 0.000 0.73
2003/03/13 09:16:10 0.000 0.64
2003/03/13 09:16:15 0.000 0.65
2003/03/13 09:16:20 0.000 0.44
2003/03/13 09:16:25 0.000 0.32
2003/03/13 09:16:30 0.000 0.26
2003/03/13 09:16:35 0.000 0.17
2003/03/13 09:16:40 0.000 0.15
2003/03/13 09:16:45 0.000 0.11
2003/03/13 09:16:50 0.000 0.08
2003/03/13 09:16:55 0.000 0.14
2003/03/13 09:17:00 0.000 0.24
2003/03/13 09:17:05 0.000 0.27
2003/03/13 09:17:10 0.000 0.22
2003/03/13 09:17:15 0.000 0.22
2003/03/13 09:17:20 0.000 0.14
2003/03/13 09:17:25 0.000 0.09
2003/03/13 09:17:30 0.000 0.09
2003/03/13 09:17:35 0.000 0.03
2003/03/13 09:17:40 0.000 0.04
2003/03/13 09:17:45 0.000 0.01
2003/03/13 09:17:50 0.000 0.02
2003/03/13 09:17:55 0.000 0.03
2003/03/13 09:18:00 0.000 -0.01

0.28

09:17:27

0.52

09:15:38

2003/03/13 09:18:05 0.000 0.01
2003/03/13 09:18:10 0.000 0.02
2003/03/13 09:18:15 0.000 0.02
2003/03/13 09:18:20 0.000 0.01
2003/03/13 09:18:25 0.000 0.05
2003/03/13 09:18:30 0.000 0.04
2003/03/13 09:18:35 0.000 0.00
2003/03/13 09:18:40 0.000 0.06
2003/03/13 09:18:45 0.000 0.01
2003/03/13 09:18:50 0.000 0.03
2003/03/13 09:18:55 0.000 0.04
2003/03/13 09:19:00 0.000 0.03
2003/03/13 09:19:05 0.000 0.05
2003/03/13 09:19:10 0.000 0.03
2003/03/13 09:19:15 0.000 0.07
2003/03/13 09:19:20 0.000 0.08
2003/03/13 09:19:25 0.000 0.08
2003/03/13 09:19:30 0.000 0.10
2003/03/13 09:19:35 0.000 0.13
2003/03/13 09:19:40 0.000 0.13
2003/03/13 09:19:45 0.000 0.10
2003/03/13 09:19:50 0.000 0.18
2003/03/13 09:19:55 0.000 0.15
2003/03/13 09:20:00 0.000 0.13
2003/03/13 09:20:05 0.000 0.17
2003/03/13 09:20:10 0.000 0.15
2003/03/13 09:20:15 0.000 0.17
2003/03/13 09:20:20 0.000 0.18
2003/03/13 09:20:25 0.000 0.18
2003/03/13 09:20:30 0.000 0.19
2003/03/13 09:20:35 0.000 0.18
2003/03/13 09:20:40 0.000 0.22
2003/03/13 09:20:45 0.000 0.23
2003/03/13 09:20:50 0.000 0.23
2003/03/13 09:20:55 0.000 0.23
2003/03/13 09:21:00 0.000 0.28
2003/03/13 09:21:05 0.000 0.25
2003/03/13 09:21:10 0.000 0.22
2003/03/13 09:21:15 0.000 0.28
2003/03/13 09:21:20 0.000 0.23
2003/03/13 09:21:25 0.000 0.25
2003/03/13 09:21:30 0.000 0.28
2003/03/13 09:21:35 0.000 0.25
2003/03/13 09:21:40 0.000 0.27
2003/03/13 09:21:45 0.000 0.25
2003/03/13 09:21:50 0.000 0.29
2003/03/13 09:21:55 0.000 0.29
2003/03/13 09:22:00 0.000 0.29
2003/03/13 09:22:05 0.000 0.32
2003/03/13 09:22:10 0.000 0.32
2003/03/13 09:22:15 0.000 0.32
2003/03/13 09:22:20 0.000 0.29
2003/03/13 09:22:25 0.000 0.35
2003/03/13 09:22:30 0.000 0.32
2003/03/13 09:22:35 0.000 0.31
2003/03/13 09:22:40 0.000 0.35
2003/03/13 09:22:45 0.000 0.32
2003/03/13 09:22:50 0.000 0.35
2003/03/13 09:22:55 0.000 0.36
2003/03/13 09:23:00 0.000 0.37
2003/03/13 09:23:05 0.000 0.38
2003/03/13 09:23:10 0.000 0.38
2003/03/13 09:23:15 0.000 0.41
2003/03/13 09:23:20 0.000 0.41
2003/03/13 09:23:25 0.000 0.41
2003/03/13 09:23:30 0.000 0.41
2003/03/13 09:23:35 0.000 0.44
2003/03/13 09:23:40 0.000 0.44
2003/03/13 09:23:45 0.000 0.41
2003/03/13 09:23:50 0.000 0.47
2003/03/13 09:23:55 0.000 0.43
2003/03/13 09:24:00 0.000 0.46
2003/03/13 09:24:05 0.000 0.46
2003/03/13 09:24:10 0.000 0.46
2003/03/13 09:24:15 0.000 0.48
2003/03/13 09:24:20 0.000 0.48
2003/03/13 09:24:25 0.000 0.49
2003/03/13 09:24:30 0.000 0.49
2003/03/13 09:24:35 0.000 0.49
2003/03/13 09:24:40 0.000 0.51
2003/03/13 09:24:45 0.000 0.52
2003/03/13 09:24:50 0.000 0.51
2003/03/13 09:24:55 0.000 0.50
2003/03/13 09:25:00 0.000 0.58
2003/03/13 09:25:05 0.000 0.54
2003/03/13 09:25:10 0.000 0.53
2003/03/13 09:25:15 0.000 0.58
2003/03/13 09:25:20 0.000 0.54
2003/03/13 09:25:25 0.000 0.57
2003/03/13 09:25:30 0.000 0.57
2003/03/13 09:25:35 0.000 0.58
2003/03/13 09:25:40 0.000 0.61
2003/03/13 09:25:45 0.000 0.59
2003/03/13 09:25:50 0.000 0.62
2003/03/13 09:25:55 0.000 0.64
2003/03/13 09:26:00 0.000 0.65
2003/03/13 09:26:05 0.000 0.65
2003/03/13 09:26:10 0.000 0.68
2003/03/13 09:26:15 0.000 0.67
2003/03/13 09:26:20 0.000 0.69
2003/03/13 09:26:25 0.000 0.71
2003/03/13 09:26:30 0.000 0.68
2003/03/13 09:26:35 0.000 0.70
2003/03/13 09:26:40 0.000 0.73
2003/03/13 09:26:45 0.000 0.72
2003/03/13 09:26:50 0.000 0.75
2003/03/13 09:26:55 0.000 0.73
2003/03/13 09:27:00 0.000 0.78
2003/03/13 09:27:05 0.000 0.78
2003/03/13 09:27:10 0.000 0.78
2003/03/13 09:27:15 0.000 0.79
2003/03/13 09:27:20 0.000 0.81
2003/03/13 09:27:25 0.000 0.80
2003/03/13 09:27:30 0.000 0.79
2003/03/13 09:27:35 0.000 0.84
2003/03/13 09:27:40 0.000 0.83
2003/03/13 09:27:45 0.000 0.82
2003/03/13 09:27:50 0.000 0.87
2003/03/13 09:27:55 0.000 0.83
2003/03/13 09:28:00 0.000 0.88
2003/03/13 09:28:05 0.000 0.88
2003/03/13 09:28:10 0.000 0.87
2003/03/13 09:28:15 0.000 0.90
2003/03/13 09:28:20 0.000 0.88
2003/03/13 09:28:25 0.000 0.92
2003/03/13 09:28:30 0.000 0.93
2003/03/13 09:28:35 0.000 0.93
2003/03/13 09:28:40 0.000 0.95
2003/03/13 09:28:45 0.000 0.97
2003/03/13 09:28:50 0.000 0.98
2003/03/13 09:28:55 0.000 0.94
2003/03/13 09:29:00 0.000 0.99
2003/03/13 09:29:05 0.000 0.98
2003/03/13 09:29:10 0.000 1.00

0.25

09:22:53.174 0.000

0.33

09:23:09.174 0.000

2003/03/13	08:28:15	0.000	1.04
2003/03/13	08:28:20	0.000	1.03
2003/03/13	08:28:25	0.000	1.05
2003/03/13	08:28:30	0.000	1.08
2003/03/13	08:28:35	0.000	1.08
2003/03/13	08:28:40	0.000	1.10
2003/03/13	08:28:45	0.000	1.08
2003/03/13	08:28:50	0.000	1.11
2003/03/13	08:28:55	0.000	1.14
2003/03/13	08:30:00	0.000	1.14
2003/03/13	08:30:05	0.000	1.12
2003/03/13	08:30:10	0.000	1.18
2003/03/13	08:30:15	0.000	1.18
2003/03/13	08:30:20	0.000	1.18
2003/03/13	08:30:25	0.000	1.22
2003/03/13	08:30:30	0.000	1.19
2003/03/13	08:30:35	0.000	1.22
2003/03/13	08:30:40	0.000	1.23
2003/03/13	08:30:45	0.000	1.23
2003/03/13	08:30:50	0.000	1.28
2003/03/13	08:30:55	0.000	1.24
2003/03/13	08:31:00	0.000	1.29
2003/03/13	08:31:05	0.000	1.29
2003/03/13	08:31:10	0.000	1.31
2003/03/13	08:31:15	0.000	1.32
2003/03/13	08:31:20	0.000	1.35
2003/03/13	08:31:25	0.000	1.35
2003/03/13	08:31:30	0.000	1.32
2003/03/13	08:31:35	0.000	1.38
2003/03/13	08:31:40	0.000	1.39
2003/03/13	08:31:45	0.000	1.39
2003/03/13	08:31:50	0.000	1.41
2003/03/13	08:31:55	0.000	1.39
2003/03/13	08:32:00	0.000	1.42
2003/03/13	08:32:05	0.000	1.41
2003/03/13	08:32:10	0.000	1.45
2003/03/13	08:32:15	0.000	1.47
2003/03/13	08:32:20	0.000	1.45
2003/03/13	08:32:25	0.000	1.49
2003/03/13	08:32:30	0.000	1.50
2003/03/13	08:32:35	0.000	1.50
2003/03/13	08:32:40	0.000	1.51
2003/03/13	08:32:45	0.000	1.58
2003/03/13	08:32:50	0.000	1.59
2003/03/13	08:32:55	0.000	1.53
2003/03/13	08:33:00	0.000	1.59
2003/03/13	08:33:05	0.000	1.53
2003/03/13	08:33:10	0.000	1.53
2003/03/13	08:33:15	0.000	1.54
2003/03/13	08:33:20	0.000	1.54
2003/03/13	08:33:25	0.000	1.54
2003/03/13	08:33:30	0.000	1.14
2003/03/13	08:33:35	0.000	0.80
2003/03/13	08:33:40	0.000	0.70
2003/03/13	08:33:45	0.000	0.62
2003/03/13	08:33:50	0.000	0.44
2003/03/13	08:33:55	0.000	0.41
2003/03/13	08:34:00	0.000	0.31
2003/03/13	08:34:05	0.000	0.22
2003/03/13	08:34:10	0.000	0.20
2003/03/13	08:34:15	0.000	0.13
2003/03/13	08:34:20	0.000	0.09
2003/03/13	08:34:25	0.000	0.12
2003/03/13	08:34:30	0.000	0.46
2003/03/13	08:34:35	0.000	0.75
2003/03/13	08:34:40	0.000	0.83
2003/03/13	08:34:45	0.000	1.14
2003/03/13	08:34:50	0.000	1.18
2003/03/13	08:34:55	0.000	1.23
2003/03/13	08:35:00	0.000	1.34
2003/03/13	08:35:05	0.000	1.39
2003/03/13	08:35:10	0.000	1.41
2003/03/13	08:35:15	0.000	1.07
2003/03/13	08:35:20	0.000	0.57
2003/03/13	08:35:25	0.000	0.85
2003/03/13	08:35:30	0.000	0.47
2003/03/13	08:35:35	0.000	0.41
2003/03/13	08:35:40	0.000	0.32
2003/03/13	08:35:45	0.000	0.28
2003/03/13	08:35:50	0.000	0.22
2003/03/13	08:35:55	0.000	0.15
2003/03/13	08:36:00	0.000	0.14
2003/03/13	08:36:05	0.000	0.08
2003/03/13	08:36:10	0.000	0.08
2003/03/13	08:36:15	0.000	0.08
2003/03/13	08:36:20	0.000	0.03
2003/03/13	08:36:25	0.000	0.05
2003/03/13	08:36:30	0.000	0.04
2003/03/13	08:36:35	0.000	0.02
2003/03/13	08:36:40	0.000	-0.01
2003/03/13	08:36:45	0.000	0.04
2003/03/13	08:36:50	0.000	0.01
2003/03/13	08:36:55	0.000	-0.01
2003/03/13	08:37:00	0.000	0.03
2003/03/13	08:37:05	0.000	-0.01
2003/03/13	08:37:10	0.000	0.01
2003/03/13	08:37:15	0.000	-0.01
2003/03/13	08:37:20	0.000	0.01
2003/03/13	08:37:25	0.000	0.02
2003/03/13	08:37:30	0.000	-0.01
2003/03/13	08:37:35	0.000	0.01
2003/03/13	08:37:40	0.000	0.00
2003/03/13	08:37:45	0.000	0.01
2003/03/13	08:37:50	0.000	0.01
2003/03/13	08:37:55	0.000	0.03
2003/03/13	08:38:00	0.000	0.01
2003/03/13	08:38:05	0.000	-0.01
2003/03/13	08:38:10	0.000	0.05
2003/03/13	08:38:15	0.000	0.01
2003/03/13	08:38:20	0.000	0.03
2003/03/13	08:38:25	0.000	0.05
2003/03/13	08:38:30	0.000	0.03
2003/03/13	08:38:35	0.000	0.05
2003/03/13	08:38:40	0.000	0.04
2003/03/13	08:38:45	0.000	0.07
2003/03/13	08:38:50	0.000	0.08
2003/03/13	08:38:55	0.000	0.07
2003/03/13	08:39:00	0.000	0.10
2003/03/13	08:39:05	0.000	0.11
2003/03/13	08:39:10	0.000	0.10
2003/03/13	08:39:15	0.000	0.08
2003/03/13	08:39:20	0.000	0.13
2003/03/13	08:39:25	0.000	0.11
2003/03/13	08:39:30	0.000	0.09
2003/03/13	08:39:35	0.000	0.14
2003/03/13	08:39:40	0.000	0.09
2003/03/13	08:39:45	0.000	0.12
2003/03/13	08:39:50	0.000	0.12
2003/03/13	08:39:55	0.000	0.12
2003/03/13	08:40:00	0.000	0.14
2003/03/13	08:40:05	0.000	0.11
2003/03/13	08:40:10	0.000	0.14
2003/03/13	08:40:15	0.000	0.13
2003/03/13	08:40:20	0.000	0.13

0.81

08:28:15 to 08:40:20

1.14

08:35:00 to 08:40:20

0.18

08:39:55 to 08:40:20

2003/03/13	08:40:25	0.000	0.14
2003/03/13	08:40:30	0.000	0.16
2003/03/13	08:40:35	0.000	0.16
2003/03/13	08:40:40	0.000	0.11
2003/03/13	08:40:45	0.000	0.16
2003/03/13	08:40:50	0.000	0.12
2003/03/13	08:40:55	0.000	0.13
2003/03/13	08:41:00	0.000	0.16
2003/03/13	08:41:05	0.000	0.13
2003/03/13	08:41:10	0.000	0.14
2003/03/13	08:41:15	0.000	0.12
2003/03/13	08:41:20	0.000	0.16
2003/03/13	08:41:25	0.000	0.16
2003/03/13	08:41:30	0.000	0.13
2003/03/13	08:41:35	0.000	0.16
2003/03/13	08:41:40	0.000	0.17
2003/03/13	08:41:45	0.000	0.16
2003/03/13	08:41:50	0.000	0.14
2003/03/13	08:41:55	0.000	0.18
2003/03/13	08:42:00	0.000	0.17
2003/03/13	08:42:05	0.000	0.14
2003/03/13	08:42:10	0.000	0.19
2003/03/13	08:42:15	0.000	0.16
2003/03/13	08:42:20	0.000	0.17
2003/03/13	08:42:25	0.000	0.16
2003/03/13	08:42:30	0.000	0.16
2003/03/13	08:42:35	0.000	0.16
2003/03/13	08:42:40	0.000	0.16
2003/03/13	08:42:45	0.000	0.19
2003/03/13	08:42:50	0.000	0.16
2003/03/13	08:42:55	0.000	0.17
2003/03/13	08:43:00	0.000	0.18
2003/03/13	08:43:05	0.000	0.21
2003/03/13	08:43:10	0.000	0.20
2003/03/13	08:43:15	0.000	0.16
2003/03/13	08:43:20	0.000	0.21
2003/03/13	08:43:25	0.000	0.18
2003/03/13	08:43:30	0.000	0.18
2003/03/13	08:43:35	0.000	0.21
2003/03/13	08:43:40	0.000	0.18
2003/03/13	08:43:45	0.000	0.18
2003/03/13	08:43:50	0.000	0.18
2003/03/13	08:43:55	0.000	0.21
2003/03/13	08:44:00	0.000	0.22
2003/03/13	08:44:05	0.000	0.20
2003/03/13	08:44:10	0.000	0.24
2003/03/13	08:44:15	0.000	0.24
2003/03/13	08:44:20	0.000	0.23
2003/03/13	08:44:25	0.000	0.22
2003/03/13	08:44:30	0.000	0.26
2003/03/13	08:44:35	0.000	0.25
2003/03/13	08:44:40	0.000	0.22
2003/03/13	08:44:45	0.000	0.26
2003/03/13	08:44:50	0.000	0.22
2003/03/13	08:44:55	0.000	0.25
2003/03/13	08:45:00	0.000	0.25
2003/03/13	08:45:05	0.000	0.26
2003/03/13	08:45:10	0.000	0.26
2003/03/13	08:45:15	0.000	0.24
2003/03/13	08:45:20	0.000	0.28
2003/03/13	08:45:25	0.000	0.28
2003/03/13	08:45:30	0.000	0.28
2003/03/13	08:45:35	0.000	0.31
2003/03/13	08:45:40	0.000	0.32
2003/03/13	08:45:45	0.000	0.32
2003/03/13	08:45:50	0.000	0.29
2003/03/13	08:45:55	0.000	0.35
2003/03/13	08:46:00	0.000	0.31
2003/03/13	08:46:05	0.000	0.31
2003/03/13	08:46:10	0.000	0.35
2003/03/13	08:46:15	0.000	0.32
2003/03/13	08:46:20	0.000	0.35
2003/03/13	08:46:25	0.000	0.33
2003/03/13	08:46:30	0.000	0.38
2003/03/13	08:46:35	0.000	0.36
2003/03/13	08:46:40	0.000	0.35
2003/03/13	08:46:45	0.000	0.39
2003/03/13	08:46:50	0.000	0.39
2003/03/13	08:46:55	0.000	0.38
2003/03/13	08:47:00	0.000	0.38
2003/03/13	08:47:05	0.000	0.43
2003/03/13	08:47:10	0.000	0.42
2003/03/13	08:47:15	0.000	0.39
2003/03/13	08:47:20	0.000	0.44
2003/03/13	08:47:25	0.000	0.41
2003/03/13	08:47:30	0.000	0.44
2003/03/13	08:47:35	0.000	0.44
2003/03/13	08:47:40	0.000	0.44
2003/03/13	08:47:45	0.000	0.47
2003/03/13	08:47:50	0.000	0.46
2003/03/13	08:47:55	0.000	0.46
2003/03/13	08:48:00	0.000	0.46
2003/03/13	08:48:05	0.000	0.46
2003/03/13	08:48:10	0.000	0.51
2003/03/13	08:48:15	0.000	0.53
2003/03/13	08:48:20	0.000	0.51
2003/03/13	08:48:25	0.000	0.49
2003/03/13	08:48:30	0.000	0.64
2003/03/13	08:48:35	0.000	0.61
2003/03/13	08:48:40	0.000	0.62
2003/03/13	08:48:45	0.000	0.66
2003/03/13	08:48:50	0.000	0.63
2003/03/13	08:48:55	0.000	0.65
2003/03/13	08:49:00	0.000	0.63
2003/03/13	08:49:05	0.000	0.66
2003/03/13	08:49:10	0.000	0.57
2003/03/13	08:49:15	0.000	0.64
2003/03/13	08:49:20	0.000	0.67
2003/03/13	08:49:25	0.000	0.67
2003/03/13	08:49:30	0.000	0.67
2003/03/13	08:49:35	0.000	0.66
2003/03/13	08:49:40	0.000	0.69
2003/03/13	08:49:45	0.000	0.67
2003/03/13	08:49:50	0.000	0.66
2003/03/13	08:49:55	0.000	0.69
2003/03/13	08:50:00	0.000	0.66
2003/03/13	08:50:05	0.000	0.66
2003/03/13	08:50:10	0.000	0.69
2003/03/13	08:50:15	0.000	0.68
2003/03/13	08:50:20	0.000	0.69
2003/03/13	08:50:25	0.000	0.67
2003/03/13	08:50:30	0.000	0.69
2003/03/13	08:50:35	0.000	0.69
2003/03/13	08:50:40	0.000	0.69
2003/03/13	08:50:45	0.000	0.61
2003/03/13	08:50:50	0.000	0.63
2003/03/13	08:50:55	0.000	0.62
2003/03/13	08:51:00	0.000	0.69
2003/03/13	08:51:05	0.000	0.66
2003/03/13	08:51:10	0.000	0.64
2003/03/13	08:51:15	0.000	0.66
2003/03/13	08:51:20	0.000	0.69
2003/03/13	08:51:25	0.000	0.66
2003/03/13	08:51:30	0.000	0.68

0.18

08:50:01 08:50:01

0.43

08:50:01 08:50:01

2003/03/13	09:01:35	0.000	0.68
2003/03/13	09:01:40	0.000	0.70
2003/03/13	09:01:45	0.000	0.71
2003/03/13	09:01:50	0.000	0.69
2003/03/13	09:01:55	0.000	0.72
2003/03/13	09:02:00	0.000	0.73
2003/03/13	09:02:05	0.000	0.73
2003/03/13	09:02:10	0.000	0.73
2003/03/13	09:02:15	0.000	0.76
2003/03/13	09:02:20	0.000	0.76
2003/03/13	09:02:25	0.000	0.72
2003/03/13	09:02:30	0.000	0.74
2003/03/13	09:02:35	0.000	0.62
2003/03/13	09:02:40	0.000	0.62
2003/03/13	09:02:45	0.000	0.41
2003/03/13	09:02:50	0.000	0.30
2003/03/13	09:02:55	0.000	0.24
2003/03/13	09:03:00	0.000	0.18
2003/03/13	09:03:05	0.000	0.14
2003/03/13	09:03:10	0.000	0.10
2003/03/13	09:03:15	0.000	0.07
2003/03/13	09:03:20	0.000	0.10
2003/03/13	09:03:25	0.000	0.21
2003/03/13	09:03:30	0.000	0.28
2003/03/13	09:03:35	0.000	0.25
2003/03/13	09:03:40	0.000	0.27
2003/03/13	09:03:45	0.000	0.18
2003/03/13	09:03:50	0.000	0.13
2003/03/13	09:03:55	0.000	0.12
2003/03/13	09:04:00	0.000	0.06
2003/03/13	09:04:05	0.000	0.05
2003/03/13	09:04:10	0.000	0.02
2003/03/13	09:04:15	0.000	0.03
2003/03/13	09:04:20	0.000	0.03
2003/03/13	09:04:25	0.000	0.00
2003/03/13	09:04:30	0.000	0.03
2003/03/13	09:04:35	0.000	0.03
2003/03/13	09:04:40	0.000	0.02
2003/03/13	09:04:45	0.000	0.01
2003/03/13	09:04:50	0.000	0.05
2003/03/13	09:04:55	0.000	0.04
2003/03/13	09:05:00	0.000	0.01
2003/03/13	09:05:05	0.000	0.06
2003/03/13	09:05:10	0.000	0.02
2003/03/13	09:05:15	0.000	0.04
2003/03/13	09:05:20	0.000	0.05
2003/03/13	09:05:25	0.000	0.04
2003/03/13	09:05:30	0.000	0.06
2003/03/13	09:05:35	0.000	0.05
2003/03/13	09:05:40	0.000	0.08
2003/03/13	09:05:45	0.000	0.08
2003/03/13	09:05:50	0.000	0.10
2003/03/13	09:05:55	0.000	0.13
2003/03/13	09:06:00	0.000	0.15
2003/03/13	09:06:05	0.000	0.15
2003/03/13	09:06:10	0.000	0.13
2003/03/13	09:06:15	0.000	0.18
2003/03/13	09:06:20	0.000	0.15
2003/03/13	09:06:25	0.000	0.15
2003/03/13	09:06:30	0.000	0.19
2003/03/13	09:06:35	0.000	0.16
2003/03/13	09:06:40	0.000	0.19
2003/03/13	09:06:45	0.000	0.18
2003/03/13	09:06:50	0.000	0.21
2003/03/13	09:06:55	0.000	0.23
2003/03/13	09:07:00	0.000	0.21
2003/03/13	09:07:05	0.000	0.25
2003/03/13	09:07:10	0.000	0.25
2003/03/13	09:07:15	0.000	0.25
2003/03/13	09:07:20	0.000	0.23
2003/03/13	09:07:25	0.000	0.27
2003/03/13	09:07:30	0.000	0.26
2003/03/13	09:07:35	0.000	0.23
2003/03/13	09:07:40	0.000	0.26
2003/03/13	09:07:45	0.000	0.24
2003/03/13	09:07:50	0.000	0.26
2003/03/13	09:07:55	0.000	0.27
2003/03/13	09:08:00	0.000	0.27
2003/03/13	09:08:05	0.000	0.30
2003/03/13	09:08:10	0.000	0.27
2003/03/13	09:08:15	0.000	0.31
2003/03/13	09:08:20	0.000	0.31
2003/03/13	09:08:25	0.000	0.31
2003/03/13	09:08:30	0.000	0.33
2003/03/13	09:08:35	0.000	0.34
2003/03/13	09:08:40	0.000	0.33
2003/03/13	09:08:45	0.000	0.31
2003/03/13	09:08:50	0.000	0.37
2003/03/13	09:08:55	0.000	0.35
2003/03/13	09:09:00	0.000	0.35
2003/03/13	09:09:05	0.000	0.38
2003/03/13	09:09:10	0.000	0.35
2003/03/13	09:09:15	0.000	0.38
2003/03/13	09:09:20	0.000	0.37
2003/03/13	09:09:25	0.000	0.40
2003/03/13	09:09:30	0.000	0.42
2003/03/13	09:09:35	0.000	0.40
2003/03/13	09:09:40	0.000	0.43
2003/03/13	09:09:45	0.000	0.45
2003/03/13	09:09:50	0.000	0.45
2003/03/13	09:09:55	0.000	0.44
2003/03/13	10:00:00	0.000	0.49
2003/03/13	10:00:05	0.000	0.47
2003/03/13	10:00:10	0.000	0.45
2003/03/13	10:00:15	0.000	0.51
2003/03/13	10:00:20	0.000	0.47
2003/03/13	10:00:25	0.000	0.50
2003/03/13	10:00:30	0.000	0.51
2003/03/13	10:00:35	0.000	0.51
2003/03/13	10:00:40	0.000	0.54
2003/03/13	10:00:45	0.000	0.52
2003/03/13	10:00:50	0.000	0.56
2003/03/13	10:00:55	0.000	0.57
2003/03/13	10:01:00	0.000	0.57
2003/03/13	10:01:05	0.000	0.60
2003/03/13	10:01:10	0.000	0.61
2003/03/13	10:01:15	0.000	0.61
2003/03/13	10:01:20	0.000	0.59
2003/03/13	10:01:25	0.000	0.64
2003/03/13	10:01:30	0.000	0.63
2003/03/13	10:01:35	0.000	0.64
2003/03/13	10:01:40	0.000	0.68
2003/03/13	10:01:45	0.000	0.68
2003/03/13	10:01:50	0.000	0.69
2003/03/13	10:01:55	0.000	0.67
2003/03/13	10:02:00	0.000	0.71
2003/03/13	10:02:05	0.000	0.73
2003/03/13	10:02:10	0.000	0.72
2003/03/13	10:02:15	0.000	0.76
2003/03/13	10:02:20	0.000	0.78
2003/03/13	10:02:25	0.000	0.77
2003/03/13	10:02:30	0.000	0.78
2003/03/13	10:02:35	0.000	0.81
2003/03/13	10:02:40	0.000	0.81

0.41

0.41

0.24

0.24

2003/03/13 10:02:45 0.000 0.79
 2003/03/13 10:02:50 0.000 0.85
 2003/03/13 10:02:55 0.000 0.81
 2003/03/13 10:03:00 0.000 0.85
 2003/03/13 10:03:05 0.000 0.86
 2003/03/13 10:03:10 0.000 0.86
 2003/03/13 10:03:15 0.000 0.89
 2003/03/13 10:03:20 0.000 0.87
 2003/03/13 10:03:25 0.000 0.91
 2003/03/13 10:03:30 0.000 0.82
 2003/03/13 10:03:35 0.000 0.94
 2003/03/13 10:03:40 0.000 0.95
 2003/03/13 10:03:45 0.000 0.93
 2003/03/13 10:03:50 0.000 0.97
 2003/03/13 10:03:55 0.000 0.94
 2003/03/13 10:04:00 0.000 0.99
 2003/03/13 10:04:05 0.000 0.95
 2003/03/13 10:04:10 0.000 0.98
 2003/03/13 10:04:15 0.000 0.98
 2003/03/13 10:04:20 0.000 0.95
 2003/03/13 10:04:25 0.000 0.97
 2003/03/13 10:04:30 0.000 0.95
 2003/03/13 10:04:35 0.000 0.98
 2003/03/13 10:04:40 0.000 0.98
 2003/03/13 10:04:45 0.000 0.96
 2003/03/13 10:04:50 0.000 0.89
 2003/03/13 10:04:55 0.000 1.00
 2003/03/13 10:05:00 0.000 1.00
 2003/03/13 10:05:05 0.000 1.00
 2003/03/13 10:05:10 0.000 1.06
 2003/03/13 10:05:15 0.000 1.06
 2003/03/13 10:05:20 0.000 1.04
 2003/03/13 10:05:25 0.000 1.09
 2003/03/13 10:05:30 0.000 1.05
 2003/03/13 10:05:35 0.000 1.09
 2003/03/13 10:05:40 0.000 1.08
 2003/03/13 10:05:45 0.000 1.08
 2003/03/13 10:05:50 0.000 1.10
 2003/03/13 10:05:55 0.000 1.08
 2003/03/13 10:06:00 0.000 1.11
 2003/03/13 10:06:05 0.000 1.10
 2003/03/13 10:06:10 0.000 1.10
 2003/03/13 10:06:15 0.000 1.12
 2003/03/13 10:06:20 0.000 1.12
 2003/03/13 10:06:25 0.000 1.11
 2003/03/13 10:06:30 0.000 1.09
 2003/03/13 10:06:35 0.000 1.13
 2003/03/13 10:06:40 0.000 1.09
 2003/03/13 10:06:45 0.000 1.09
 2003/03/13 10:06:50 0.000 1.12
 2003/03/13 10:06:55 0.000 1.09
 2003/03/13 10:07:00 0.000 1.11
 2003/03/13 10:07:05 0.000 1.08
 2003/03/13 10:07:10 0.000 1.11
 2003/03/13 10:07:15 0.000 1.11
 2003/03/13 10:07:20 0.000 1.09
 2003/03/13 10:07:25 0.000 1.12
 2003/03/13 10:07:30 0.000 1.12
 2003/03/13 10:07:35 0.000 1.10
 2003/03/13 10:07:40 0.000 1.09
 2003/03/13 10:07:45 0.000 1.13
 2003/03/13 10:07:50 0.000 1.11
 2003/03/13 10:07:55 0.000 1.08
 2003/03/13 10:08:00 0.000 1.13
 2003/03/13 10:08:05 0.000 1.09
 2003/03/13 10:08:10 0.000 1.11
 2003/03/13 10:08:15 0.000 1.11
 2003/03/13 10:08:20 0.000 1.11
 2003/03/13 10:08:25 0.000 1.14
 2003/03/13 10:08:30 0.000 1.10
 2003/03/13 10:08:35 0.000 1.13
 2003/03/13 10:08:40 0.000 1.13
 2003/03/13 10:08:45 0.000 1.12
 2003/03/13 10:08:50 0.000 1.13
 2003/03/13 10:08:55 0.000 1.16
 2003/03/13 10:09:00 0.000 1.13
 2003/03/13 10:09:05 0.000 1.11
 2003/03/13 10:09:10 0.000 1.16
 2003/03/13 10:09:15 0.000 1.12
 2003/03/13 10:09:20 0.000 1.13
 2003/03/13 10:09:25 0.000 1.15
 2003/03/13 10:09:30 0.000 1.12
 2003/03/13 10:09:35 0.000 1.13
 2003/03/13 10:09:40 0.000 1.09
 2003/03/13 10:09:45 0.000 1.12
 2003/03/13 10:09:50 0.000 1.13
 2003/03/13 10:09:55 0.000 1.06
 2003/03/13 10:10:00 0.000 0.75
 2003/03/13 10:10:05 0.000 0.69
 2003/03/13 10:10:10 0.000 0.45
 2003/03/13 10:10:15 0.000 0.39
 2003/03/13 10:10:20 0.000 0.37
 2003/03/13 10:10:25 0.000 0.27
 2003/03/13 10:10:30 0.000 0.18
 2003/03/13 10:10:35 0.000 0.17
 2003/03/13 10:10:40 0.000 0.10
 2003/03/13 10:10:45 0.000 0.09
 2003/03/13 10:10:50 0.000 0.07
 2003/03/13 10:10:55 0.000 0.11
 2003/03/13 10:11:00 0.000 0.26
 2003/03/13 10:11:05 0.000 0.31
 2003/03/13 10:11:10 0.000 0.35
 2003/03/13 10:11:15 0.000 0.34
 2003/03/13 10:11:20 0.000 0.39
 2003/03/13 10:11:25 0.000 0.38
 2003/03/13 10:11:30 0.000 0.38
 2003/03/13 10:11:35 0.000 0.35
 2003/03/13 10:11:40 0.000 0.27
 2003/03/13 10:11:45 0.000 0.27
 2003/03/13 10:11:50 0.000 0.18
 2003/03/13 10:11:55 0.000 0.14
 2003/03/13 10:12:00 0.000 0.13
 2003/03/13 10:12:05 0.000 0.08
 2003/03/13 10:12:10 0.000 0.07
 2003/03/13 10:12:15 0.000 0.03
 2003/03/13 10:12:20 0.000 0.04
 2003/03/13 10:12:25 0.000 0.04
 2003/03/13 10:12:30 0.000 0.01
 2003/03/13 10:12:35 0.000 0.02
 2003/03/13 10:12:40 0.000 0.03
 2003/03/13 10:12:45 0.000 0.02
 2003/03/13 10:12:50 0.000 -0.01
 2003/03/13 10:12:55 0.000 0.04
 2003/03/13 10:13:00 0.000 0.02
 2003/03/13 10:13:05 0.000 -0.01
 2003/03/13 10:13:10 0.000 0.03
 2003/03/13 10:13:15 0.000 -0.02
 2003/03/13 10:13:20 0.000 0.00
 2003/03/13 10:13:25 0.000 0.00
 2003/03/13 10:13:30 0.000 0.00
 2003/03/13 10:13:35 0.000 0.01
 2003/03/13 10:13:40 0.000 -0.01
 2003/03/13 10:13:45 0.000 0.02
 2003/03/13 10:13:50 0.000 0.00

0.78

2003/03/13 10:02:45

1.10

2003/03/13 10:09:55

2003/03/13	10:13:55	0.000	0.01
2003/03/13	10:14:00	0.000	0.01
2003/03/13	10:14:05	0.000	0.03
2003/03/13	10:14:10	0.000	0.02
2003/03/13	10:14:15	0.000	-0.02
2003/03/13	10:14:20	0.000	0.03
2003/03/13	10:14:25	0.000	-0.01
2003/03/13	10:14:30	0.000	0.00
2003/03/13	10:14:35	0.000	0.01
2003/03/13	10:14:40	0.000	-0.01
2003/03/13	10:14:45	0.000	0.00
2003/03/13	10:14:50	0.000	-0.02
2003/03/13	10:14:55	0.000	0.01
2003/03/13	10:15:00	0.000	0.01
2003/03/13	10:15:05	0.000	-0.01
2003/03/13	10:15:10	0.000	0.02
2003/03/13	10:15:15	0.000	0.02
2003/03/13	10:15:20	0.000	0.01
2003/03/13	10:15:25	0.000	-0.01
2003/03/13	10:15:30	0.000	0.03
2003/03/13	10:15:35	0.000	0.01
2003/03/13	10:15:40	0.000	-0.01
2003/03/13	10:15:45	0.000	0.03
2003/03/13	10:15:50	0.000	-0.02
2003/03/13	10:15:55	0.000	0.01
2003/03/13	10:16:00	0.000	0.00
2003/03/13	10:16:05	0.000	0.00
2003/03/13	10:16:10	0.000	0.01
2003/03/13	10:16:15	0.000	-0.01
2003/03/13	10:16:20	0.000	0.02
2003/03/13	10:16:25	0.000	0.01
2003/03/13	10:16:30	0.000	0.01
2003/03/13	10:16:35	0.000	0.01
2003/03/13	10:16:40	0.000	0.03
2003/03/13	10:16:45	0.000	0.01
2003/03/13	10:16:50	0.000	-0.02
2003/03/13	10:16:55	0.000	0.03
2003/03/13	10:17:00	0.000	-0.01
2003/03/13	10:17:05	0.000	0.00
2003/03/13	10:17:10	0.000	0.01
2003/03/13	10:17:15	0.000	-0.01
2003/03/13	10:17:20	0.000	0.01
2003/03/13	10:17:25	0.000	-0.02
2003/03/13	10:17:30	0.000	0.01
2003/03/13	10:17:35	0.000	0.01
2003/03/13	10:17:40	0.000	0.00
2003/03/13	10:17:45	0.000	0.02
2003/03/13	10:17:50	0.000	0.02
2003/03/13	10:17:55	0.000	0.01
2003/03/13	10:18:00	0.000	-0.01
2003/03/13	10:18:05	0.000	0.03
2003/03/13	10:18:10	0.000	0.01
2003/03/13	10:18:15	0.000	-0.01
2003/03/13	10:18:20	0.000	0.03
2003/03/13	10:18:25	0.000	-0.02
2003/03/13	10:18:30	0.000	0.01
2003/03/13	10:18:35	0.000	0.00
2003/03/13	10:18:40	0.000	0.00
2003/03/13	10:18:45	0.000	0.02
2003/03/13	10:18:50	0.000	-0.01
2003/03/13	10:18:55	0.000	0.01
2003/03/13	10:19:00	0.000	0.01
2003/03/13	10:19:05	0.000	0.01
2003/03/13	10:19:10	0.000	0.03
2003/03/13	10:19:15	0.000	0.01
2003/03/13	10:19:20	0.000	-0.01
2003/03/13	10:19:25	0.000	0.03
2003/03/13	10:19:30	0.000	-0.01
2003/03/13	10:19:35	0.000	0.00
2003/03/13	10:19:40	0.000	0.00
2003/03/13	10:19:45	0.000	0.01
2003/03/13	10:19:50	0.000	-0.01
2003/03/13	10:19:55	0.000	0.01
2003/03/13	10:20:00	0.000	-0.02
2003/03/13	10:20:05	0.000	0.01
2003/03/13	10:20:10	0.000	0.01
2003/03/13	10:20:15	0.000	0.00
2003/03/13	10:20:20	0.000	0.02
2003/03/13	10:20:25	0.000	0.02
2003/03/13	10:20:30	0.000	0.01
2003/03/13	10:20:35	0.000	-0.01
2003/03/13	10:20:40	0.000	0.03
2003/03/13	10:20:45	0.000	0.01
2003/03/13	10:20:50	0.000	-0.01
2003/03/13	10:20:55	0.000	0.03
2003/03/13	10:21:00	0.000	-0.02
2003/03/13	10:21:05	0.000	0.01
2003/03/13	10:21:10	0.000	0.00
2003/03/13	10:21:15	0.000	0.00
2003/03/13	10:21:20	0.000	0.02
2003/03/13	10:21:25	0.000	-0.01
2003/03/13	10:21:30	0.000	0.01
2003/03/13	10:21:35	0.000	0.01
2003/03/13	10:21:40	0.000	0.01
2003/03/13	10:21:45	0.000	0.00
2003/03/13	10:21:50	0.000	0.03
2003/03/13	10:21:55	0.000	0.02
2003/03/13	10:22:00	0.000	-0.02
2003/03/13	10:22:05	0.000	0.03
2003/03/13	10:22:10	0.000	-0.01
2003/03/13	10:22:15	0.000	0.00
2003/03/13	10:22:20	0.000	0.01
2003/03/13	10:22:25	0.000	-0.01
2003/03/13	10:22:30	0.000	0.01
2003/03/13	10:22:35	0.000	-0.01
2003/03/13	10:22:40	0.000	0.01
2003/03/13	10:22:45	0.000	0.01
2003/03/13	10:22:50	0.000	0.00
2003/03/13	10:22:55	0.000	0.01
2003/03/13	10:23:00	0.000	0.03
2003/03/13	10:23:05	0.000	0.01
2003/03/13	10:23:10	0.000	-0.01
2003/03/13	10:23:15	0.000	0.03
2003/03/13	10:23:20	0.000	0.01
2003/03/13	10:23:25	0.000	-0.01
2003/03/13	10:23:30	0.000	0.02
2003/03/13	10:23:35	0.000	-0.01
2003/03/13	10:23:40	0.000	0.01
2003/03/13	10:23:45	0.000	-0.01
2003/03/13	10:23:50	0.000	0.00
2003/03/13	10:23:55	0.000	0.01
2003/03/13	10:24:00	0.000	-0.01
2003/03/13	10:24:05	0.000	0.02
2003/03/13	10:24:10	0.000	0.01
2003/03/13	10:24:15	0.000	0.01
2003/03/13	10:24:20	0.000	0.00
2003/03/13	10:24:25	0.000	0.03
2003/03/13	10:24:30	0.000	0.02
2003/03/13	10:24:35	0.000	-0.02
2003/03/13	10:24:40	0.000	0.03
2003/03/13	10:24:45	0.000	-0.01
2003/03/13	10:24:50	0.000	0.00
2003/03/13	10:24:55	0.000	0.01
2003/03/13	10:25:00	0.000	-0.01

0.13

BPAM0001 HP/03/24

0.01

BPAM0001 HP/03/24

0.01

BPAM0001 HP/03/24

2003/03/13	10:28:05	0.000	0.00
2003/03/13	10:28:10	0.000	-0.02
2003/03/13	10:28:16	0.000	0.01
2003/03/13	10:28:20	0.000	0.01
2003/03/13	10:28:25	0.000	0.00
2003/03/13	10:28:30	0.000	0.02
2003/03/13	10:28:35	0.000	0.03
2003/03/13	10:28:40	0.000	0.01
2003/03/13	10:28:45	0.000	-0.01
2003/03/13	10:28:50	0.000	0.03
2003/03/13	10:28:55	0.000	0.01
2003/03/13	10:29:00	0.000	-0.01
2003/03/13	10:29:05	0.000	0.02
2003/03/13	10:29:10	0.000	-0.01
2003/03/13	10:29:15	0.000	0.01
2003/03/13	10:29:20	0.000	-0.01
2003/03/13	10:29:25	0.000	0.00
2003/03/13	10:29:30	0.000	0.01
2003/03/13	10:29:35	0.000	-0.01
2003/03/13	10:29:40	0.000	0.01
2003/03/13	10:29:45	0.000	-0.02
2003/03/13	10:29:50	0.000	0.01
2003/03/13	10:29:55	0.000	0.01
2003/03/13	10:30:00	0.000	0.00
2003/03/13	10:30:05	0.000	0.03
2003/03/13	10:30:10	0.000	0.01
2003/03/13	10:30:15	0.000	0.03
2003/03/13	10:30:20	0.000	0.03
2003/03/13	10:30:25	0.000	0.01
2003/03/13	10:30:30	0.000	0.01
2003/03/13	10:30:35	0.000	0.00
2003/03/13	10:30:40	0.000	0.02
2003/03/13	10:30:45	0.000	0.02
2003/03/13	10:30:50	0.000	0.02
2003/03/13	10:30:55	0.000	-0.02
2003/03/13	10:31:00	0.000	0.03
2003/03/13	10:31:05	0.000	0.00
2003/03/13	10:31:10	0.000	-0.01
2003/03/13	10:31:15	0.000	0.02
2003/03/13	10:31:20	0.000	-0.01
2003/03/13	10:31:25	0.000	0.00
2003/03/13	10:31:30	0.000	-0.01
2003/03/13	10:31:35	0.000	0.01
2003/03/13	10:31:40	0.000	0.02
2003/03/13	10:31:45	0.000	-0.01
2003/03/13	10:31:50	0.000	0.01
2003/03/13	10:31:55	0.000	0.01
2003/03/13	10:32:00	0.000	0.01
2003/03/13	10:32:05	0.000	0.00
2003/03/13	10:32:10	0.000	0.03
2003/03/13	10:32:15	0.000	0.03
2003/03/13	10:32:20	0.000	-0.01
2003/03/13	10:32:25	0.000	0.03
2003/03/13	10:32:30	0.000	-0.01
2003/03/13	10:32:35	0.000	0.01
2003/03/13	10:32:40	0.000	0.02
2003/03/13	10:32:45	0.000	0.00
2003/03/13	10:32:50	0.000	0.01
2003/03/13	10:32:55	0.000	-0.01
2003/03/13	10:33:00	0.000	0.02
2003/03/13	10:33:05	0.000	0.02
2003/03/13	10:33:10	0.000	0.01
2003/03/13	10:33:15	0.000	0.02
2003/03/13	10:33:20	0.000	0.04
2003/03/13	10:33:25	0.000	0.03
2003/03/13	10:33:30	0.000	0.00
2003/03/13	10:33:35	0.000	0.05
2003/03/13	10:33:40	0.000	0.02
2003/03/13	10:33:45	0.000	0.00
2003/03/13	10:33:50	0.000	0.04
2003/03/13	10:33:55	0.000	0.00
2003/03/13	10:34:00	0.000	0.02
2003/03/13	10:34:05	0.000	0.01
2003/03/13	10:34:10	0.000	0.02
2003/03/13	10:34:15	0.000	0.03
2003/03/13	10:34:20	0.000	0.00
2003/03/13	10:34:25	0.000	0.04
2003/03/13	10:34:30	0.000	0.03
2003/03/13	10:34:35	0.000	0.03
2003/03/13	10:34:40	0.000	0.02
2003/03/13	10:34:45	0.000	0.05
2003/03/13	10:34:50	0.000	0.03
2003/03/13	10:34:55	0.000	0.00
2003/03/13	10:35:00	0.000	0.05
2003/03/13	10:35:05	0.000	0.01
2003/03/13	10:35:10	0.000	0.02
2003/03/13	10:35:15	0.000	0.03
2003/03/13	10:35:20	0.000	0.01
2003/03/13	10:35:25	0.000	0.02
2003/03/13	10:35:30	0.000	0.00
2003/03/13	10:35:35	0.000	0.03
2003/03/13	10:35:40	0.000	0.02
2003/03/13	10:35:45	0.000	0.02
2003/03/13	10:35:50	0.000	0.04
2003/03/13	10:35:55	0.000	0.04
2003/03/13	10:36:00	0.000	0.03
2003/03/13	10:36:05	0.000	0.00
2003/03/13	10:36:10	0.000	0.05

0.01

20030313 10:35:00

0.01

20030313 10:35:00

2003/03/13	10:28:15	0.000	0.02
2003/03/13	10:28:20	0.000	0.01
2003/03/13	10:28:25	0.000	0.04
2003/03/13	10:28:30	0.000	0.01
2003/03/13	10:28:35	0.000	0.03
2003/03/13	10:28:40	0.000	0.01
2003/03/13	10:28:45	0.000	0.03
2003/03/13	10:28:50	0.000	0.03
2003/03/13	10:28:55	0.000	0.01
2003/03/13	10:29:00	0.000	0.04
2003/03/13	10:29:05	0.000	0.04
2003/03/13	10:29:10	0.000	0.03
2003/03/13	10:29:15	0.000	0.02
2003/03/13	10:29:20	0.000	0.05
2003/03/13	10:29:25	0.000	0.04
2003/03/13	10:29:30	0.000	0.01
2003/03/13	10:29:35	0.000	0.05
2003/03/13	10:29:40	0.000	0.01
2003/03/13	10:29:45	0.000	0.03
2003/03/13	10:29:50	0.000	0.03
2003/03/13	10:29:55	0.000	0.02
2003/03/13	10:30:00	0.000	0.04
2003/03/13	10:30:05	0.000	0.00
2003/03/13	10:30:10	0.000	0.03
2003/03/13	10:30:15	0.000	0.03
2003/03/13	10:30:20	0.000	0.03
2003/03/13	10:30:25	0.000	0.02
2003/03/13	10:30:30	0.000	0.04
2003/03/13	10:30:35	0.000	0.03
2003/03/13	10:30:40	0.000	0.01
2003/03/13	10:30:45	0.000	0.05
2003/03/13	10:30:50	0.000	0.03
2003/03/13	10:30:55	0.000	0.01
2003/03/13	10:31:00	0.000	0.05
2003/03/13	10:31:05	0.000	0.01
2003/03/13	10:31:10	0.000	0.05
2003/03/13	10:31:15	0.000	0.01
2003/03/13	10:31:20	0.000	0.06
2003/03/13	10:31:25	0.000	0.03
2003/03/13	10:31:30	0.000	0.02
2003/03/13	10:31:35	0.000	0.05
2003/03/13	10:31:40	0.000	0.02
2003/03/13	10:31:45	0.000	0.04
2003/03/13	10:31:50	0.000	0.02
2003/03/13	10:31:55	0.000	0.04
2003/03/13	10:32:00	0.000	0.05
2003/03/13	10:32:05	0.000	0.02
2003/03/13	10:32:10	0.000	0.04
2003/03/13	10:32:15	0.000	0.05
2003/03/13	10:32:20	0.000	0.04
2003/03/13	10:32:25	0.000	0.03
2003/03/13	10:32:30	0.000	0.06
2003/03/13	10:32:35	0.000	0.06
2003/03/13	10:32:40	0.000	0.02
2003/03/13	10:32:45	0.000	0.07
2003/03/13	10:32:50	0.000	0.03
2003/03/13	10:32:55	0.000	0.04
2003/03/13	10:33:00	0.000	0.05
2003/03/13	10:33:05	0.000	0.03
2003/03/13	10:33:10	0.000	0.05
2003/03/13	10:33:15	0.000	0.03
2003/03/13	10:33:20	0.000	0.06
2003/03/13	10:33:25	0.000	0.05
2003/03/13	10:33:30	0.000	0.04
2003/03/13	10:33:35	0.000	0.05
2003/03/13	10:33:40	0.000	0.07
2003/03/13	10:33:45	0.000	0.06
2003/03/13	10:33:50	0.000	0.03
2003/03/13	10:33:55	0.000	0.08
2003/03/13	10:34:00	0.000	0.05
2003/03/13	10:34:05	0.000	0.04
2003/03/13	10:34:10	0.000	0.07
2003/03/13	10:34:15	0.000	0.04
2003/03/13	10:34:20	0.000	0.06
2003/03/13	10:34:25	0.000	0.05
2003/03/13	10:34:30	0.000	0.07
2003/03/13	10:34:35	0.000	0.06
2003/03/13	10:34:40	0.000	0.06
2003/03/13	10:34:45	0.000	0.09
2003/03/13	10:34:50	0.000	0.06
2003/03/13	10:34:55	0.000	0.06
2003/03/13	10:35:00	0.000	0.07
2003/03/13	10:35:05	0.000	0.11
2003/03/13	10:35:10	0.000	0.10
2003/03/13	10:35:15	0.000	0.06
2003/03/13	10:35:20	0.000	0.11
2003/03/13	10:35:25	0.000	0.07
2003/03/13	10:35:30	0.000	0.09
2003/03/13	10:35:35	0.000	0.06
2003/03/13	10:35:40	0.000	0.06
2003/03/13	10:35:45	0.000	0.08
2003/03/13	10:35:50	0.000	0.10
2003/03/13	10:35:55	0.000	0.08
2003/03/13	10:36:00	0.000	0.11
2003/03/13	10:36:05	0.000	0.02
2003/03/13	10:36:10	0.000	-0.01
2003/03/13	10:36:15	0.000	0.01
2003/03/13	10:36:20	0.000	-0.01
2003/03/13	10:36:25	0.000	0.02

0.03

20030313 10:36:25

0.04

20030313 10:36:30

2003/03/13	10:47:25	0.00	0.02
2003/03/13	10:47:30	0.00	0.04
2003/03/13	10:47:35	0.00	0.04
2003/03/13	10:47:40	0.00	0.08
2003/03/13	10:47:45	0.00	0.08
2003/03/13	10:47:50	0.00	0.08
2003/03/13	10:47:55	0.00	0.11
2003/03/13	10:48:00	0.00	0.08
2003/03/13	10:48:05	0.00	0.08
2003/03/13	10:48:10	0.00	0.07
2003/03/13	10:48:15	0.00	0.04
2003/03/13	10:48:20	0.00	0.05
2003/03/13	10:48:25	0.00	0.01
2003/03/13	10:48:30	0.00	0.03
2003/03/13	10:48:35	0.00	0.01
2003/03/13	10:48:40	0.00	0.00
2003/03/13	10:48:45	0.00	0.02
2003/03/13	10:48:50	0.00	0.02
2003/03/13	10:48:55	0.00	0.01
2003/03/13	10:49:00	0.00	-0.01
2003/03/13	10:49:05	0.00	0.03
2003/03/13	10:49:10	0.00	0.00
2003/03/13	10:49:15	0.00	-0.01
2003/03/13	10:49:20	0.00	0.02
2003/03/13	10:49:25	0.00	-0.01
2003/03/13	10:49:30	0.00	0.01
2003/03/13	10:49:35	0.00	-0.01
2003/03/13	10:49:40	0.00	0.01
2003/03/13	10:49:45	0.00	0.02
2003/03/13	10:49:50	0.00	-0.01
2003/03/13	10:49:55	0.00	0.01
2003/03/13	10:50:00	0.00	0.01
2003/03/13	10:50:05	0.00	0.01
2003/03/13	10:50:10	0.00	0.00
2003/03/13	10:50:15	0.00	0.03
2003/03/13	10:50:20	0.00	0.01
2003/03/13	10:50:25	0.00	-0.01
2003/03/13	10:50:30	0.00	0.03
2003/03/13	10:50:35	0.00	-0.02
2003/03/13	10:50:40	0.00	0.00
2003/03/13	10:50:45	0.00	0.01
2003/03/13	10:50:50	0.00	-0.01
2003/03/13	10:50:55	0.00	0.01
2003/03/13	10:51:00	0.00	-0.02
2003/03/13	10:51:05	0.00	0.01
2003/03/13	10:51:10	0.00	0.01
2003/03/13	10:51:15	0.00	0.00
2003/03/13	10:51:20	0.00	0.02
2003/03/13	10:51:25	0.00	0.02
2003/03/13	10:51:30	0.00	0.02
2003/03/13	10:51:35	0.00	-0.02
2003/03/13	10:51:40	0.00	0.03
2003/03/13	10:51:45	0.00	0.00
2003/03/13	10:51:50	0.00	-0.01
2003/03/13	10:51:55	0.00	0.02
2003/03/13	10:52:00	0.00	-0.01
2003/03/13	10:52:05	0.00	0.01
2003/03/13	10:52:10	0.00	-0.01
2003/03/13	10:52:15	0.00	0.01
2003/03/13	10:52:20	0.00	0.02
2003/03/13	10:52:25	0.00	-0.01
2003/03/13	10:52:30	0.00	0.01
2003/03/13	10:52:35	0.00	0.01
2003/03/13	10:52:40	0.00	0.01
2003/03/13	10:52:45	0.00	0.00
2003/03/13	10:52:50	0.00	0.03
2003/03/13	10:52:55	0.00	0.02
2003/03/13	10:53:00	0.00	-0.02
2003/03/13	10:53:05	0.00	0.03
2003/03/13	10:53:10	0.00	-0.01
2003/03/13	10:53:15	0.00	0.00
2003/03/13	10:53:20	0.00	0.01
2003/03/13	10:53:25	0.00	-0.01
2003/03/13	10:53:30	0.00	0.01
2003/03/13	10:53:35	0.00	-0.01
2003/03/13	10:53:40	0.00	0.02
2003/03/13	10:53:45	0.00	0.01
2003/03/13	10:53:50	0.00	0.00
2003/03/13	10:53:55	0.00	0.01
2003/03/13	10:54:00	0.00	0.03
2003/03/13	10:54:05	0.00	0.01
2003/03/13	10:54:10	0.00	-0.02
2003/03/13	10:54:15	0.00	0.03
2003/03/13	10:54:20	0.00	0.01
2003/03/13	10:54:25	0.00	-0.01
2003/03/13	10:54:30	0.00	0.02
2003/03/13	10:54:35	0.00	-0.01
2003/03/13	10:54:40	0.00	0.01
2003/03/13	10:54:45	0.00	-0.01
2003/03/13	10:54:50	0.00	0.01
2003/03/13	10:54:55	0.00	0.01
2003/03/13	10:55:00	0.00	-0.01
2003/03/13	10:55:05	0.00	0.02
2003/03/13	10:55:10	0.00	0.01
2003/03/13	10:55:15	0.00	0.01
2003/03/13	10:55:20	0.00	0.00
2003/03/13	10:55:25	0.00	0.03
2003/03/13	10:55:30	0.00	0.02
2003/03/13	10:55:35	0.00	-0.02
2003/03/13	10:55:40	0.00	0.03
2003/03/13	10:55:45	0.00	-0.01
2003/03/13	10:55:50	0.00	0.00
2003/03/13	10:55:55	0.00	0.01
2003/03/13	10:56:00	0.00	-0.01
2003/03/13	10:56:05	0.00	0.00
2003/03/13	10:56:10	0.00	-0.02
2003/03/13	10:56:15	0.00	0.01
2003/03/13	10:56:20	0.00	0.01
2003/03/13	10:56:25	0.00	0.00
2003/03/13	10:56:30	0.00	0.02
2003/03/13	10:56:35	0.00	0.03
2003/03/13	10:56:40	0.00	0.01
2003/03/13	10:56:45	0.00	-0.01
2003/03/13	10:56:50	0.00	0.03
2003/03/13	10:56:55	0.00	0.01
2003/03/13	10:57:00	0.00	-0.01
2003/03/13	10:57:05	0.00	0.02
2003/03/13	10:57:10	0.00	-0.01
2003/03/13	10:57:15	0.00	0.01
2003/03/13	10:57:20	0.00	-0.01
2003/03/13	10:57:25	0.00	0.01
2003/03/13	10:57:30	0.00	0.01
2003/03/13	10:57:35	0.00	-0.01
2003/03/13	10:57:40	0.00	0.02
2003/03/13	10:57:45	0.00	0.01
2003/03/13	10:57:50	0.00	0.01
2003/03/13	10:57:55	0.00	0.00
2003/03/13	10:58:00	0.00	0.03
2003/03/13	10:58:05	0.00	0.01
2003/03/13	10:58:10	0.00	-0.02
2003/03/13	10:58:15	0.00	0.03
2003/03/13	10:58:20	0.00	-0.01
2003/03/13	10:58:25	0.00	0.00
2003/03/13	10:58:30	0.00	0.01

0.05

2003/03/13 10:58:30

0.01

2003/03/13 10:58:30

2003/03/13 10:58:38 0.000 0.00
2003/03/13 10:58:40 0.000 0.02
2003/03/13 10:58:45 0.000 -0.02
2003/03/13 10:58:50 0.000 0.01
2003/03/13 10:58:55 0.000 0.01
2003/03/13 10:59:00 0.000 0.00
2003/03/13 10:59:05 0.000 0.02
2003/03/13 10:59:10 0.000 0.03
2003/03/13 10:59:15 0.000 0.01
2003/03/13 10:59:20 0.000 -0.01
2003/03/13 10:59:25 0.000 0.03
2003/03/13 10:59:30 0.000 0.00
2003/03/13 10:59:35 0.000 -0.01
2003/03/13 10:59:40 0.000 0.02
2003/03/13 10:59:45 0.000 -0.01
2003/03/13 10:59:50 0.000 0.01
2003/03/13 10:59:55 0.000 -0.01
2003/03/13 11:00:00 0.000 0.01
2003/03/13 11:00:05 0.000 0.02
2003/03/13 11:00:10 0.000 -0.01
2003/03/13 11:00:15 0.000 0.01
2003/03/13 11:00:20 0.000 0.01
2003/03/13 11:00:25 0.000 0.01
2003/03/13 11:00:30 0.000 0.00
2003/03/13 11:00:35 0.000 0.03
2003/03/13 11:00:40 0.000 0.01
2003/03/13 11:00:45 0.000 -0.01
2003/03/13 11:00:50 0.000 0.03
2003/03/13 11:00:55 0.000 -0.01
2003/03/13 11:01:00 0.000 0.00
2003/03/13 11:01:05 0.000 0.01
2003/03/13 11:01:10 0.000 -0.01
2003/03/13 11:01:15 0.000 0.02
2003/03/13 11:01:20 0.000 -0.02
2003/03/13 11:01:25 0.000 0.01
2003/03/13 11:01:30 0.000 0.01
2003/03/13 11:01:35 0.000 0.00
2003/03/13 11:01:40 0.000 0.02
2003/03/13 11:01:45 0.000 0.03
2003/03/13 11:01:50 0.000 0.01
2003/03/13 11:01:55 0.000 -0.02
2003/03/13 11:02:00 0.000 0.03
2003/03/13 11:02:05 0.000 0.00
2003/03/13 11:02:10 0.000 -0.01
2003/03/13 11:02:15 0.000 0.02
2003/03/13 11:02:20 0.000 -0.01
2003/03/13 11:02:25 0.000 0.00
2003/03/13 11:02:30 0.000 -0.01
2003/03/13 11:02:35 0.000 0.01
2003/03/13 11:02:40 0.000 0.02
2003/03/13 11:02:45 0.000 -0.01
2003/03/13 11:02:50 0.000 0.01
2003/03/13 11:02:55 0.000 0.01
2003/03/13 11:03:00 0.000 0.01
2003/03/13 11:03:05 0.000 0.00
2003/03/13 11:03:10 0.000 0.03
2003/03/13 11:03:15 0.000 0.02
2003/03/13 11:03:20 0.000 -0.02
2003/03/13 11:03:25 0.000 0.03
2003/03/13 11:03:30 0.000 -0.01
2003/03/13 11:03:35 0.000 0.00
2003/03/13 11:03:40 0.000 0.01
2003/03/13 11:03:45 0.000 -0.01
2003/03/13 11:03:50 0.000 0.01
2003/03/13 11:03:55 0.000 -0.01
2003/03/13 11:04:00 0.000 0.02
2003/03/13 11:04:05 0.000 0.01
2003/03/13 11:04:10 0.000 0.00
2003/03/13 11:04:15 0.000 0.01
2003/03/13 11:04:20 0.000 0.03
2003/03/13 11:04:25 0.000 0.01
2003/03/13 11:04:30 0.000 -0.02
2003/03/13 11:04:35 0.000 0.03
2003/03/13 11:04:40 0.000 0.01
2003/03/13 11:04:45 0.000 -0.01
2003/03/13 11:04:50 0.000 0.02
2003/03/13 11:04:55 0.000 -0.01
2003/03/13 11:05:00 0.000 0.00
2003/03/13 11:05:05 0.000 -0.01
2003/03/13 11:05:10 0.000 0.01
2003/03/13 11:05:15 0.000 0.01
2003/03/13 11:05:20 0.000 -0.01
2003/03/13 11:05:25 0.000 0.02
2003/03/13 11:05:30 0.000 0.01
2003/03/13 11:05:35 0.000 0.01
2003/03/13 11:05:40 0.000 0.00
2003/03/13 11:05:45 0.000 0.03
2003/03/13 11:05:50 0.000 0.02
2003/03/13 11:05:55 0.000 -0.02
2003/03/13 11:06:00 0.000 0.03
2003/03/13 11:06:05 0.000 -0.01
2003/03/13 11:06:10 0.000 0.00
2003/03/13 11:06:15 0.000 0.01
2003/03/13 11:06:20 0.000 -0.01
2003/03/13 11:06:25 0.000 0.00
2003/03/13 11:06:30 0.000 -0.02
2003/03/13 11:06:35 0.000 0.01
2003/03/13 11:06:40 0.000 0.01
2003/03/13 11:06:45 0.000 0.00
2003/03/13 11:06:50 0.000 0.02
2003/03/13 11:06:55 0.000 0.03
2003/03/13 11:07:00 0.000 0.01
2003/03/13 11:07:05 0.000 -0.01
2003/03/13 11:07:10 0.000 0.03
2003/03/13 11:07:15 0.000 0.01
2003/03/13 11:07:20 0.000 -0.01
2003/03/13 11:07:25 0.000 0.02
2003/03/13 11:07:30 0.000 -0.01
2003/03/13 11:07:35 0.000 0.01
2003/03/13 11:07:40 0.000 -0.01
2003/03/13 11:07:45 0.000 0.00
2003/03/13 11:07:50 0.000 0.01
2003/03/13 11:07:55 0.000 -0.01
2003/03/13 11:08:00 0.000 0.02
2003/03/13 11:08:05 0.000 0.01
2003/03/13 11:08:10 0.000 0.01
2003/03/13 11:08:15 0.000 0.01
2003/03/13 11:08:20 0.000 0.03
2003/03/13 11:08:25 0.000 0.01
2003/03/13 11:08:30 0.000 -0.02
2003/03/13 11:08:35 0.000 0.03
2003/03/13 11:08:40 0.000 -0.01
2003/03/13 11:08:45 0.000 0.00
2003/03/13 11:08:50 0.000 0.01
2003/03/13 11:08:55 0.000 -0.01
2003/03/13 11:09:00 0.000 0.01
2003/03/13 11:09:05 0.000 -0.02
2003/03/13 11:09:10 0.000 0.01
2003/03/13 11:09:15 0.000 0.01
2003/03/13 11:09:20 0.000 0.00
2003/03/13 11:09:25 0.000 0.02
2003/03/13 11:09:30 0.000 0.02
2003/03/13 11:09:35 0.000 0.01
2003/03/13 11:09:40 0.000 0.01
2003/03/13 11:09:45 0.000 -0.01

0.01

RECORDED INFORMATION

0.01

RECORDED INFORMATION

2003/03/18 11:09:48 0.000 0.03
2003/03/18 11:09:50 0.000 0.01
2003/03/18 11:09:55 -0.000 -0.01
2003/03/18 11:10:00 0.000 0.03
2003/03/18 11:10:05 0.000 -0.01
2003/03/18 11:10:10 0.000 0.01
2003/03/18 11:10:15 0.000 0.00
2003/03/18 11:10:20 0.000 0.00
2003/03/18 11:10:25 0.000 0.02
2003/03/18 11:10:30 0.000 -0.01
2003/03/18 11:10:35 0.000 0.01
2003/03/18 11:10:40 0.000 0.01
2003/03/18 11:10:45 0.000 0.01
2003/03/18 11:10:50 0.000 0.01
2003/03/18 11:10:55 0.000 0.03
2003/03/18 11:11:00 0.000 0.01
2003/03/18 11:11:05 0.000 -0.01
2003/03/18 11:11:10 0.000 0.03
2003/03/18 11:11:15 0.000 -0.01
2003/03/18 11:11:20 0.000 0.00
2003/03/18 11:11:25 0.000 0.01
2003/03/18 11:11:30 0.000 -0.01
2003/03/18 11:11:35 0.000 0.01
2003/03/18 11:11:40 0.000 -0.02
2003/03/18 11:11:45 0.000 0.01
2003/03/18 11:11:50 0.000 0.01
2003/03/18 11:11:55 0.000 -0.01
2003/03/18 11:12:00 0.000 0.02
2003/03/18 11:12:05 0.000 0.02
2003/03/18 11:12:10 0.000 0.01
2003/03/18 11:12:15 0.000 -0.01
2003/03/18 11:12:20 0.000 0.03
2003/03/18 11:12:25 0.000 0.01
2003/03/18 11:12:30 0.000 -0.01
2003/03/18 11:12:35 0.000 0.03
2003/03/18 11:12:40 0.000 -0.02
2003/03/18 11:12:45 0.000 0.00
2003/03/18 11:12:50 0.000 0.00
2003/03/18 11:12:55 0.000 0.03
2003/03/18 11:13:00 0.000 0.02
2003/03/18 11:13:05 0.000 -0.01
2003/03/18 11:13:10 0.000 0.01
2003/03/18 11:13:15 0.000 0.01
2003/03/18 11:13:20 0.000 0.01
2003/03/18 11:13:25 0.000 0.01
2003/03/18 11:13:30 0.000 0.03
2003/03/18 11:13:35 0.000 0.02
2003/03/18 11:13:40 0.000 -0.02
2003/03/18 11:13:45 0.000 0.03
2003/03/18 11:13:50 0.000 -0.01
2003/03/18 11:13:55 0.000 0.00
2003/03/18 11:14:00 0.000 0.02
2003/03/18 11:14:05 0.000 -0.01
2003/03/18 11:14:10 0.000 0.01
2003/03/18 11:14:15 0.000 -0.01
2003/03/18 11:14:20 0.000 0.01
2003/03/18 11:14:25 0.000 0.01
2003/03/18 11:14:30 0.000 -0.01
2003/03/18 11:14:35 0.000 0.01
2003/03/18 11:14:40 0.000 0.02
2003/03/18 11:14:45 0.000 0.01
2003/03/18 11:14:50 0.000 -0.01
2003/03/18 11:14:55 0.000 0.03
2003/03/18 11:15:00 0.000 0.02
2003/03/18 11:15:05 0.000 -0.01
2003/03/18 11:15:10 0.000 0.03
2003/03/18 11:15:15 0.000 -0.02
2003/03/18 11:15:20 0.000 0.00
2003/03/18 11:15:25 0.000 0.00
2003/03/18 11:15:30 0.000 0.00
2003/03/18 11:15:35 0.000 0.01
2003/03/18 11:15:40 0.000 -0.01
2003/03/18 11:15:45 0.000 0.02
2003/03/18 11:15:50 0.000 0.00
2003/03/18 11:15:55 0.000 0.00
2003/03/18 11:16:00 0.000 0.01
2003/03/18 11:16:05 0.000 0.03
2003/03/18 11:16:10 0.000 0.02
2003/03/18 11:16:15 0.000 -0.02
2003/03/18 11:16:20 0.000 0.03
2003/03/18 11:16:25 0.000 0.00
2003/03/18 11:16:30 0.000 -0.01
2003/03/18 11:16:35 0.000 0.02
2003/03/18 11:16:40 0.000 -0.01
2003/03/18 11:16:45 0.000 0.00
2003/03/18 11:16:50 0.000 -0.01
2003/03/18 11:16:55 0.000 0.01
2003/03/18 11:17:00 0.000 0.01
2003/03/18 11:17:05 0.000 -0.01
2003/03/18 11:17:10 0.000 0.02
2003/03/18 11:17:15 0.000 0.01
2003/03/18 11:17:20 0.000 0.01
2003/03/18 11:17:25 0.000 0.00
2003/03/18 11:17:30 0.000 0.03
2003/03/18 11:17:35 0.000 0.02
2003/03/18 11:17:40 0.000 -0.01
2003/03/18 11:17:45 0.000 0.03
2003/03/18 11:17:50 0.000 -0.01
2003/03/18 11:17:55 0.000 0.01
2003/03/18 11:18:00 0.000 0.01
2003/03/18 11:18:05 0.000 -0.01
2003/03/18 11:18:10 0.000 0.00
2003/03/18 11:18:15 0.000 -0.01
2003/03/18 11:18:20 0.000 0.01
2003/03/18 11:18:25 0.000 0.01
2003/03/18 11:18:30 0.000 0.00
2003/03/18 11:18:35 0.000 0.03
2003/03/18 11:18:40 0.000 0.02
2003/03/18 11:18:45 0.000 0.01
2003/03/18 11:18:50 0.000 -0.01
2003/03/18 11:18:55 0.000 0.04
2003/03/18 11:19:00 0.000 0.01
2003/03/18 11:19:05 0.000 -0.01
2003/03/18 11:19:10 0.000 0.03
2003/03/18 11:19:15 0.000 -0.01
2003/03/18 11:19:20 0.000 0.02
2003/03/18 11:19:25 0.000 0.00
2003/03/18 11:19:30 0.000 0.01
2003/03/18 11:19:35 0.000 0.01
2003/03/18 11:19:40 0.000 0.00
2003/03/18 11:19:45 0.000 0.03
2003/03/18 11:19:50 0.000 0.02
2003/03/18 11:19:55 0.000 0.02
2003/03/18 11:20:00 0.000 0.02
2003/03/18 11:20:05 0.000 0.04
2003/03/18 11:20:10 0.000 0.03
2003/03/18 11:20:15 0.000 0.00
2003/03/18 11:20:20 0.000 0.05
2003/03/18 11:20:25 0.000 0.01
2003/03/18 11:20:30 0.000 0.02
2003/03/18 11:20:35 0.000 0.03
2003/03/18 11:20:40 0.000 0.02
2003/03/18 11:20:45 0.000 0.04
2003/03/18 11:20:50 0.000 0.01

0.01

RESOLUTION

0.01

RESOLUTION

0.01

RESOLUTION

2003/03/13	11:20:55	0.00	0.03
2003/03/13	11:21:00	0.00	0.03
2003/03/13	11:21:05	0.00	0.03
2003/03/13	11:21:10	0.00	0.05
2003/03/13	11:21:15	0.00	0.05
2003/03/13	11:21:20	0.00	0.04
2003/03/13	11:21:25	0.00	0.02
2003/03/13	11:21:30	0.00	0.07
2003/03/13	11:21:35	0.00	0.05
2003/03/13	11:21:40	0.00	0.03
2003/03/13	11:21:45	0.00	0.07
2003/03/13	11:21:50	0.00	0.03
2003/03/13	11:21:55	0.00	0.06
2003/03/13	11:22:00	0.00	0.05
2003/03/13	11:22:05	0.00	0.06
2003/03/13	11:22:10	0.00	0.06
2003/03/13	11:22:15	0.00	0.05
2003/03/13	11:22:20	0.00	0.07
2003/03/13	11:22:25	0.00	0.07
2003/03/13	11:22:30	0.00	0.07
2003/03/13	11:22:35	0.00	0.07
2003/03/13	11:22:40	0.00	0.08
2003/03/13	11:22:45	0.00	0.07
2003/03/13	11:22:50	0.00	0.04
2003/03/13	11:22:55	0.00	0.07
2003/03/13	11:23:00	0.00	0.02
2003/03/13	11:23:05	0.00	0.01
2003/03/13	11:23:10	0.00	0.02
2003/03/13	11:23:15	0.00	-0.01
2003/03/13	11:23:20	0.00	0.01
2003/03/13	11:23:25	0.00	-0.01
2003/03/13	11:23:30	0.00	0.01
2003/03/13	11:23:35	0.00	0.01
2003/03/13	11:23:40	0.00	-0.01
2003/03/13	11:23:45	0.00	0.02
2003/03/13	11:23:50	0.00	0.02
2003/03/13	11:23:55	0.00	0.02
2003/03/13	11:24:00	0.00	0.02
2003/03/13	11:24:05	0.00	0.08
2003/03/13	11:24:10	0.00	0.07
2003/03/13	11:24:15	0.00	0.06
2003/03/13	11:24:20	0.00	0.10
2003/03/13	11:24:25	0.00	0.06
2003/03/13	11:24:30	0.00	0.06
2003/03/13	11:24:35	0.00	0.07
2003/03/13	11:24:40	0.00	0.06
2003/03/13	11:24:45	0.00	0.06
2003/03/13	11:24:50	0.00	0.00
2003/03/13	11:24:55	0.00	0.02
2003/03/13	11:25:00	0.00	0.00
2003/03/13	11:25:05	0.00	0.00
2003/03/13	11:25:10	0.00	0.01
2003/03/13	11:25:15	0.00	0.03
2003/03/13	11:25:20	0.00	0.02
2003/03/13	11:25:25	0.00	-0.02
2003/03/13	11:25:30	0.00	0.03
2003/03/13	11:25:35	0.00	0.00
2003/03/13	11:25:40	0.00	-0.01
2003/03/13	11:25:45	0.00	0.02
2003/03/13	11:25:50	0.00	-0.01
2003/03/13	11:25:55	0.00	0.01
2003/03/13	11:26:00	0.00	-0.01
2003/03/13	11:26:05	0.00	0.01
2003/03/13	11:26:10	0.00	0.01
2003/03/13	11:26:15	0.00	-0.01
2003/03/13	11:26:20	0.00	0.01
2003/03/13	11:26:25	0.00	0.01
2003/03/13	11:26:30	0.00	0.01
2003/03/13	11:26:35	0.00	0.00
2003/03/13	11:26:40	0.00	0.03
2003/03/13	11:26:45	0.00	0.02
2003/03/13	11:26:50	0.00	-0.01
2003/03/13	11:26:55	0.00	0.03
2003/03/13	11:27:00	0.00	-0.01
2003/03/13	11:27:05	0.00	0.00
2003/03/13	11:27:10	0.00	0.01
2003/03/13	11:27:15	0.00	-0.01
2003/03/13	11:27:20	0.00	0.01
2003/03/13	11:27:25	0.00	-0.01
2003/03/13	11:27:30	0.00	0.02
2003/03/13	11:27:35	0.00	0.00
2003/03/13	11:27:40	0.00	0.00
2003/03/13	11:27:45	0.00	0.01
2003/03/13	11:27:50	0.00	0.02
2003/03/13	11:27:55	0.00	0.01
2003/03/13	11:28:00	0.00	-0.01
2003/03/13	11:28:05	0.00	0.03
2003/03/13	11:28:10	0.00	0.01
2003/03/13	11:28:15	0.00	-0.01
2003/03/13	11:28:20	0.00	0.02
2003/03/13	11:28:25	0.00	-0.01
2003/03/13	11:28:30	0.00	0.00
2003/03/13	11:28:35	0.00	-0.01
2003/03/13	11:28:40	0.00	0.01
2003/03/13	11:28:45	0.00	0.01
2003/03/13	11:28:50	0.00	-0.01
2003/03/13	11:28:55	0.00	0.02
2003/03/13	11:29:00	0.00	0.01
2003/03/13	11:29:05	0.00	0.01
2003/03/13	11:29:10	0.00	0.00
2003/03/13	11:29:15	0.00	0.03
2003/03/13	11:29:20	0.00	0.02
2003/03/13	11:29:25	0.00	-0.02
2003/03/13	11:29:30	0.00	0.03
2003/03/13	11:29:35	0.00	-0.01
2003/03/13	11:29:40	0.00	0.00
2003/03/13	11:29:45	0.00	0.01
2003/03/13	11:29:50	0.00	0.01
2003/03/13	11:29:55	0.00	-0.01
2003/03/13	11:30:00	0.00	0.00
2003/03/13	11:30:05	0.00	0.01
2003/03/13	11:30:10	0.00	0.01
2003/03/13	11:30:15	0.00	0.00
2003/03/13	11:30:20	0.00	0.03
2003/03/13	11:30:25	0.00	0.02
2003/03/13	11:30:30	0.00	0.01
2003/03/13	11:30:35	0.00	-0.01
2003/03/13	11:30:40	0.00	0.03
2003/03/13	11:30:45	0.00	0.01
2003/03/13	11:30:50	0.00	-0.01
2003/03/13	11:30:55	0.00	0.03
2003/03/13	11:31:00	0.00	-0.01
2003/03/13	11:31:05	0.00	0.01
2003/03/13	11:31:10	0.00	0.00
2003/03/13	11:31:15	0.00	0.00
2003/03/13	11:31:20	0.00	0.01
2003/03/13	11:31:25	0.00	-0.01
2003/03/13	11:31:30	0.00	0.02
2003/03/13	11:31:35	0.00	0.00
2003/03/13	11:31:40	0.00	0.01
2003/03/13	11:31:45	0.00	0.01
2003/03/13	11:31:50	0.00	0.03
2003/03/13	11:31:55	0.00	0.01
2003/03/13	11:32:00	0.00	-0.02

0.04

ENR030713.MW0013

0.01

ENR030713.MW0013

2003/03/13	11:32:08	0.000	0.03
2003/03/13	11:32:10	0.000	-0.01
2003/03/13	11:32:15	0.000	0.00
2003/03/13	11:32:20	0.000	0.02
2003/03/13	11:32:25	0.000	-0.01
2003/03/13	11:32:30	0.000	0.01
2003/03/13	11:32:35	0.000	-0.02
2003/03/13	11:32:40	0.000	0.01
2003/03/13	11:32:45	0.000	0.01
2003/03/13	11:32:50	0.000	-0.01
2003/03/13	11:32:55	0.000	0.02
2003/03/13	11:33:00	0.000	0.02
2003/03/13	11:33:05	0.000	0.01
2003/03/13	11:33:10	0.000	-0.01
2003/03/13	11:33:15	0.000	0.03
2003/03/13	11:33:20	0.000	0.01
2003/03/13	11:33:25	0.000	-0.01
2003/03/13	11:33:30	0.000	0.03
2003/03/13	11:33:35	0.000	-0.02
2003/03/13	11:33:40	0.000	0.01
2003/03/13	11:33:45	0.000	0.00
2003/03/13	11:33:50	0.000	0.00
2003/03/13	11:33:55	0.000	0.02
2003/03/13	11:34:00	0.000	-0.01
2003/03/13	11:34:05	0.000	0.01
2003/03/13	11:34:10	0.000	0.00
2003/03/13	11:34:15	0.000	0.01
2003/03/13	11:34:20	0.000	0.01
2003/03/13	11:34:25	0.000	0.03
2003/03/13	11:34:30	0.000	0.01
2003/03/13	11:34:35	0.000	-0.01
2003/03/13	11:34:40	0.000	0.03
2003/03/13	11:34:45	0.000	0.00
2003/03/13	11:34:50	0.000	0.00
2003/03/13	11:34:55	0.000	0.02
2003/03/13	11:35:00	0.000	-0.01
2003/03/13	11:35:05	0.000	0.01
2003/03/13	11:35:10	0.000	-0.01
2003/03/13	11:35:15	0.000	0.01
2003/03/13	11:35:20	0.000	0.01
2003/03/13	11:35:25	0.000	-0.01
2003/03/13	11:35:30	0.000	0.02
2003/03/13	11:35:35	0.000	0.01
2003/03/13	11:35:40	0.000	0.01
2003/03/13	11:35:45	0.000	-0.01
2003/03/13	11:35:50	0.000	0.03
2003/03/13	11:35:55	0.000	0.01
2003/03/13	11:36:00	0.000	-0.01
2003/03/13	11:36:05	0.000	0.03
2003/03/13	11:36:10	0.000	-0.02
2003/03/13	11:36:15	0.000	0.03
2003/03/13	11:36:20	0.000	0.01
2003/03/13	11:36:25	0.000	0.01
2003/03/13	11:36:30	0.000	0.00
2003/03/13	11:36:35	0.000	0.02
2003/03/13	11:36:40	0.000	0.01
2003/03/13	11:36:45	0.000	0.00
2003/03/13	11:36:50	0.000	0.00
2003/03/13	11:36:55	0.000	0.02
2003/03/13	11:37:00	0.000	0.03
2003/03/13	11:37:05	0.000	0.02
2003/03/13	11:37:10	0.000	-0.02
2003/03/13	11:37:15	0.000	0.03
2003/03/13	11:37:20	0.000	0.00
2003/03/13	11:37:25	0.000	-0.01
2003/03/13	11:37:30	0.000	0.02
2003/03/13	11:37:35	0.000	-0.01
2003/03/13	11:37:40	0.000	0.01
2003/03/13	11:37:45	0.000	-0.01
2003/03/13	11:37:50	0.000	0.01
2003/03/13	11:37:55	0.000	0.02
2003/03/13	11:38:00	0.000	-0.01
2003/03/13	11:38:05	0.000	0.01
2003/03/13	11:38:10	0.000	0.01
2003/03/13	11:38:15	0.000	0.01
2003/03/13	11:38:20	0.000	0.01
2003/03/13	11:38:25	0.000	0.00
2003/03/13	11:38:30	0.000	0.02
2003/03/13	11:38:35	0.000	-0.01
2003/03/13	11:38:40	0.000	0.03
2003/03/13	11:38:45	0.000	-0.01
2003/03/13	11:38:50	0.000	0.00
2003/03/13	11:38:55	0.000	0.01
2003/03/13	11:39:00	0.000	-0.01
2003/03/13	11:39:05	0.000	0.01
2003/03/13	11:39:10	0.000	-0.01
2003/03/13	11:39:15	0.000	0.01
2003/03/13	11:39:20	0.000	0.01
2003/03/13	11:39:25	0.000	0.00
2003/03/13	11:39:30	0.000	0.01
2003/03/13	11:39:35	0.000	0.02
2003/03/13	11:39:40	0.000	0.01
2003/03/13	11:39:45	0.000	-0.01
2003/03/13	11:39:50	0.000	0.03
2003/03/13	11:39:55	0.000	0.01
2003/03/13	11:40:00	0.000	-0.01
2003/03/13	11:40:05	0.000	0.02
2003/03/13	11:40:10	0.000	-0.01
2003/03/13	11:40:15	0.000	0.01
2003/03/13	11:40:20	0.000	-0.01
2003/03/13	11:40:25	0.000	0.01
2003/03/13	11:40:30	0.000	0.01
2003/03/13	11:40:35	0.000	-0.01
2003/03/13	11:40:40	0.000	0.02
2003/03/13	11:40:45	0.000	0.01
2003/03/13	11:40:50	0.000	0.01
2003/03/13	11:40:55	0.000	0.01
2003/03/13	11:41:00	0.000	0.04
2003/03/13	11:41:05	0.000	0.03
2003/03/13	11:41:10	0.000	-0.01
2003/03/13	11:41:15	0.000	0.04
2003/03/13	11:41:20	0.000	0.00
2003/03/13	11:41:25	0.000	0.01
2003/03/13	11:41:30	0.000	0.02
2003/03/13	11:41:35	0.000	0.00
2003/03/13	11:41:40	0.000	0.01
2003/03/13	11:41:45	0.000	-0.01
2003/03/13	11:41:50	0.000	0.02
2003/03/13	11:41:55	0.000	0.02
2003/03/13	11:42:00	0.000	0.01
2003/03/13	11:42:05	0.000	0.03
2003/03/13	11:42:10	0.000	0.02
2003/03/13	11:42:15	0.000	0.01
2003/03/13	11:42:20	0.000	-0.01
2003/03/13	11:42:25	0.000	0.03
2003/03/13	11:42:30	0.000	0.01
2003/03/13	11:42:35	0.000	-0.01
2003/03/13	11:42:40	0.000	0.03
2003/03/13	11:42:45	0.000	-0.01
2003/03/13	11:42:50	0.000	0.01
2003/03/13	11:42:55	0.000	0.00
2003/03/13	11:43:00	0.000	0.00
2003/03/13	11:43:05	0.000	0.01
2003/03/13	11:43:10	0.000	-0.01

0.01

0.01

0.01

0.01

2003/03/13	11:43:15	0.000	0.02
2003/03/13	11:43:20	0.000	0.00
2003/03/13	11:43:25	0.000	0.01
2003/03/13	11:43:30	0.000	0.01
2003/03/13	11:43:35	0.000	0.03
2003/03/13	11:43:40	0.000	0.01
2003/03/13	11:43:45	0.000	-0.02
2003/03/13	11:43:50	0.000	0.03
2003/03/13	11:43:55	0.000	-0.01
2003/03/13	11:44:00	0.000	0.00
2003/03/13	11:44:05	0.000	0.02
2003/03/13	11:44:10	0.000	-0.01
2003/03/13	11:44:15	0.000	0.01
2003/03/13	11:44:20	0.000	-0.01
2003/03/13	11:44:25	0.000	0.01
2003/03/13	11:44:30	0.000	0.01
2003/03/13	11:44:35	0.000	-0.01
2003/03/13	11:44:40	0.000	0.02
2003/03/13	11:44:45	0.000	0.02
2003/03/13	11:44:50	0.000	0.01
2003/03/13	11:44:55	0.000	-0.01
2003/03/13	11:45:00	0.000	0.03
2003/03/13	11:45:05	0.000	0.01
2003/03/13	11:45:10	0.000	-0.01
2003/03/13	11:45:15	0.000	0.03
2003/03/13	11:45:20	0.000	-0.02
2003/03/13	11:45:25	0.000	0.01
2003/03/13	11:45:30	0.000	0.00
2003/03/13	11:45:35	0.000	0.00
2003/03/13	11:45:40	0.000	0.02
2003/03/13	11:45:45	0.000	-0.01
2003/03/13	11:45:50	0.000	0.01
2003/03/13	11:45:55	0.000	-0.01
2003/03/13	11:46:00	0.000	0.01
2003/03/13	11:46:05	0.000	0.00
2003/03/13	11:46:10	0.000	0.01
2003/03/13	11:46:15	0.000	0.01
2003/03/13	11:46:20	0.000	0.03
2003/03/13	11:46:25	0.000	-0.01
2003/03/13	11:46:30	0.000	0.03
2003/03/13	11:46:35	0.000	0.00
2003/03/13	11:46:40	0.000	0.02
2003/03/13	11:46:45	0.000	-0.01
2003/03/13	11:46:50	0.000	0.01
2003/03/13	11:46:55	0.000	-0.01
2003/03/13	11:47:00	0.000	0.01
2003/03/13	11:47:05	0.000	0.01
2003/03/13	11:47:10	0.000	-0.01
2003/03/13	11:47:15	0.000	0.01
2003/03/13	11:47:20	0.000	0.01
2003/03/13	11:47:25	0.000	0.01
2003/03/13	11:47:30	0.000	-0.01
2003/03/13	11:47:35	0.000	0.03
2003/03/13	11:47:40	0.000	0.01
2003/03/13	11:47:45	0.000	-0.01
2003/03/13	11:47:50	0.000	0.03
2003/03/13	11:47:55	0.000	-0.02
2003/03/13	11:48:00	0.000	0.00
2003/03/13	11:48:05	0.000	0.01
2003/03/13	11:48:10	0.000	0.00
2003/03/13	11:48:15	0.000	0.02
2003/03/13	11:48:20	0.000	-0.01
2003/03/13	11:48:25	0.000	0.01
2003/03/13	11:48:30	0.000	0.00
2003/03/13	11:48:35	0.000	0.00
2003/03/13	11:48:40	0.000	0.02
2003/03/13	11:48:45	0.000	0.03
2003/03/13	11:48:50	0.000	0.02
2003/03/13	11:48:55	0.000	-0.02
2003/03/13	11:49:00	0.000	0.03
2003/03/13	11:49:05	0.000	0.00
2003/03/13	11:49:10	0.000	-0.01
2003/03/13	11:49:15	0.000	0.02
2003/03/13	11:49:20	0.000	-0.01
2003/03/13	11:49:25	0.000	0.01
2003/03/13	11:49:30	0.000	-0.01
2003/03/13	11:49:35	0.000	0.01
2003/03/13	11:49:40	0.000	0.01
2003/03/13	11:49:45	0.000	-0.01
2003/03/13	11:49:50	0.000	0.01
2003/03/13	11:49:55	0.000	0.01
2003/03/13	11:50:00	0.000	0.01
2003/03/13	11:50:05	0.000	0.00
2003/03/13	11:50:10	0.000	0.03
2003/03/13	11:50:15	0.000	0.02
2003/03/13	11:50:20	0.000	-0.01
2003/03/13	11:50:25	0.000	0.03
2003/03/13	11:50:30	0.000	-0.01
2003/03/13	11:50:35	0.000	0.00
2003/03/13	11:50:40	0.000	0.01
2003/03/13	11:50:45	0.000	-0.01
2003/03/13	11:50:50	0.000	0.01
2003/03/13	11:50:55	0.000	-0.01
2003/03/13	11:51:00	0.000	0.02
2003/03/13	11:51:05	0.000	0.01
2003/03/13	11:51:10	0.000	0.00
2003/03/13	11:51:15	0.000	0.01
2003/03/13	11:51:20	0.000	0.03
2003/03/13	11:51:25	0.000	0.01
2003/03/13	11:51:30	0.000	-0.01
2003/03/13	11:51:35	0.000	0.03
2003/03/13	11:51:40	0.000	0.01
2003/03/13	11:51:45	0.000	-0.01
2003/03/13	11:51:50	0.000	0.02
2003/03/13	11:51:55	0.000	-0.01
2003/03/13	11:52:00	0.000	0.00
2003/03/13	11:52:05	0.000	-0.01
2003/03/13	11:52:10	0.000	0.01
2003/03/13	11:52:15	0.000	0.01
2003/03/13	11:52:20	0.000	-0.01
2003/03/13	11:52:25	0.000	0.02
2003/03/13	11:52:30	0.000	0.01
2003/03/13	11:52:35	0.000	0.01
2003/03/13	11:52:40	0.000	0.00
2003/03/13	11:52:45	0.000	0.03
2003/03/13	11:52:50	0.000	0.02
2003/03/13	11:52:55	0.000	-0.02
2003/03/13	11:53:00	0.000	0.03
2003/03/13	11:53:05	0.000	-0.01
2003/03/13	11:53:10	0.000	0.00
2003/03/13	11:53:15	0.000	0.01
2003/03/13	11:53:20	0.000	-0.01
2003/03/13	11:53:25	0.000	0.00
2003/03/13	11:53:30	0.000	-0.01
2003/03/13	11:53:35	0.000	0.01
2003/03/13	11:53:40	0.000	0.01
2003/03/13	11:53:45	0.000	0.00
2003/03/13	11:53:50	0.000	0.03
2003/03/13	11:53:55	0.000	0.02
2003/03/13	11:54:00	0.000	0.01
2003/03/13	11:54:05	0.000	-0.01
2003/03/13	11:54:10	0.000	0.03
2003/03/13	11:54:15	0.000	0.01
2003/03/13	11:54:20	0.000	-0.01

0.01

RESERVED

0.01

RESERVED

2003/03/13	11:54:28	0.000	0.03
2003/03/13	11:54:30	0.000	-0.01
2003/03/13	11:54:35	0.000	0.01
2003/03/13	11:54:40	0.000	0.00
2003/03/13	11:54:45	0.000	0.00
2003/03/13	11:54:50	0.000	0.01
2003/03/13	11:54:55	0.000	-0.01
2003/03/13	11:55:00	0.000	0.02
2003/03/13	11:55:05	0.000	0.00
2003/03/13	11:55:10	0.000	0.01
2003/03/13	11:55:15	0.000	0.01
2003/03/13	11:55:20	0.000	0.03
2003/03/13	11:55:25	0.000	0.01
2003/03/13	11:55:30	0.000	0.82
2003/03/13	11:55:35	0.000	1.81
2003/03/13	11:55:40	0.000	2.27
2003/03/13	11:55:45	0.000	2.82
2003/03/13	11:55:50	0.000	3.28
2003/03/13	11:55:55	0.000	3.59
2003/03/13	11:56:00	0.000	3.88
2003/03/13	11:56:05	0.000	4.02
2003/03/13	11:56:10	0.000	4.20
2003/03/13	11:56:15	0.000	4.31
2003/03/13	11:56:20	0.000	4.31
2003/03/13	11:56:25	0.000	4.42
2003/03/13	11:56:30	0.000	4.49
2003/03/13	11:56:35	0.000	4.61
2003/03/13	11:56:40	0.000	4.64
2003/03/13	11:56:45	0.000	4.81
2003/03/13	11:56:50	0.000	4.81
2003/03/13	11:56:55	0.000	4.81
2003/03/13	11:57:00	0.000	4.85
2003/03/13	11:57:05	0.000	4.82
2003/03/13	11:57:10	0.000	4.87
2003/03/13	11:57:15	0.000	4.88
2003/03/13	11:57:20	0.000	4.88
2003/03/13	11:57:25	0.000	4.69
2003/03/13	11:57:30	0.000	4.21
2003/03/13	11:57:35	0.000	3.48
2003/03/13	11:57:40	0.000	2.74
2003/03/13	11:57:45	0.000	2.14
2003/03/13	11:57:50	0.000	1.67
2003/03/13	11:57:55	0.000	1.33
2003/03/13	11:58:00	0.000	1.01
2003/03/13	11:58:05	0.000	0.77
2003/03/13	11:58:10	0.000	0.65
2003/03/13	11:58:15	0.000	0.47
2003/03/13	11:58:20	0.000	0.35
2003/03/13	11:58:25	0.000	0.35
2003/03/13	11:58:30	0.000	0.27
2003/03/13	11:58:35	0.000	0.23
2003/03/13	11:58:40	0.000	0.15
2003/03/13	11:58:45	0.000	0.14
2003/03/13	11:58:50	0.000	0.15
2003/03/13	11:58:55	0.000	0.43
2003/03/13	11:59:00	0.000	0.89
2003/03/13	11:59:05	0.000	0.85
2003/03/13	11:59:10	0.000	1.01
2003/03/13	11:59:15	0.000	1.07
2003/03/13	11:59:20	0.000	1.14
2003/03/13	11:59:25	0.000	1.20
2003/03/13	11:59:30	0.000	1.25
2003/03/13	11:59:35	0.000	1.35
2003/03/13	11:59:40	0.000	1.35
2003/03/13	11:59:45	0.000	1.40
2003/03/13	11:59:50	0.000	1.43
2003/03/13	11:59:55	0.000	1.44
2003/03/13	12:00:00	0.000	1.48
2003/03/13	12:00:05	0.000	1.45
2003/03/13	12:00:10	0.000	1.48
2003/03/13	12:00:15	0.000	1.43
2003/03/13	12:00:20	0.000	1.49
2003/03/13	12:00:25	0.000	1.50
2003/03/13	12:00:30	0.000	1.52
2003/03/13	12:00:35	0.000	1.51
2003/03/13	12:00:40	0.000	1.48
2003/03/13	12:00:45	0.000	1.52
2003/03/13	12:00:50	0.000	1.41
2003/03/13	12:00:55	0.000	0.98
2003/03/13	12:01:00	0.000	0.77
2003/03/13	12:01:05	0.000	0.58
2003/03/13	12:01:10	0.000	0.45
2003/03/13	12:01:15	0.000	0.39
2003/03/13	12:01:20	0.000	0.35
2003/03/13	12:01:25	0.000	0.28
2003/03/13	12:01:30	0.000	0.19
2003/03/13	12:01:35	0.000	0.17
2003/03/13	12:01:40	0.000	0.14
2003/03/13	12:01:45	0.000	0.10
2003/03/13	12:01:50	0.000	0.07
2003/03/13	12:01:55	0.000	0.08
2003/03/13	12:02:00	0.000	0.08
2003/03/13	12:02:05	0.000	0.01
2003/03/13	12:02:10	0.000	0.05
2003/03/13	12:02:15	0.000	0.01
2003/03/13	12:02:20	0.000	0.01
2003/03/13	12:02:25	0.000	0.02
2003/03/13	12:02:30	0.000	0.00
2003/03/13	12:02:35	0.000	0.04
2003/03/13	12:02:40	0.000	0.80
2003/03/13	12:02:45	0.000	1.03
2003/03/13	12:02:50	0.000	1.35
2003/03/13	12:02:55	0.000	1.80
2003/03/13	12:03:00	0.000	1.83
2003/03/13	12:03:05	0.000	2.02
2003/03/13	12:03:10	0.000	2.13
2003/03/13	12:03:15	0.000	2.17
2003/03/13	12:03:20	0.000	2.28
2003/03/13	12:03:25	0.000	2.31
2003/03/13	12:03:30	0.000	2.35
2003/03/13	12:03:35	0.000	2.43
2003/03/13	12:03:40	0.000	2.41
2003/03/13	12:03:45	0.000	2.48
2003/03/13	12:03:50	0.000	2.48
2003/03/13	12:03:55	0.000	2.51
2003/03/13	12:04:00	0.000	2.54
2003/03/13	12:04:05	0.000	2.52
2003/03/13	12:04:10	0.000	2.55
2003/03/13	12:04:15	0.000	2.55
2003/03/13	12:04:20	0.000	2.55
2003/03/13	12:04:25	0.000	2.68
2003/03/13	12:04:30	0.000	2.68
2003/03/13	12:04:35	0.000	2.68
2003/03/13	12:04:40	0.000	2.83
2003/03/13	12:04:45	0.000	2.18
2003/03/13	12:04:50	0.000	1.70
2003/03/13	12:04:55	0.000	1.37
2003/03/13	12:05:00	0.000	1.08
2003/03/13	12:05:05	0.000	0.81
2003/03/13	12:05:10	0.000	0.65
2003/03/13	12:05:15	0.000	0.48
2003/03/13	12:05:20	0.000	0.39
2003/03/13	12:05:25	0.000	0.87
2003/03/13	12:05:30	0.000	0.29

0.01

MESSAGES

MESSAGES

2003/03/13	12:06:35	0.000	0.25
2003/03/13	12:06:40	0.000	0.20
2003/03/13	12:06:48	0.000	0.14
2003/03/13	12:06:50	0.000	0.09
2003/03/13	12:06:55	0.000	0.11
2003/03/13	12:06:00	0.000	0.07
2003/03/13	12:06:05	0.000	0.03
2003/03/13	12:06:10	0.000	0.08
2003/03/13	12:06:15	0.000	0.01
2003/03/13	12:06:20	0.000	0.03
2003/03/13	12:06:25	0.000	0.01
2003/03/13	12:06:30	0.000	0.01
2003/03/13	12:06:35	0.000	0.01
2003/03/13	12:06:40	0.000	-0.01
2003/03/13	12:06:45	0.000	0.02
2003/03/13	12:06:50	0.000	0.01
2003/03/13	12:06:55	0.000	0.01
2003/03/13	12:07:00	0.000	0.02
2003/03/13	12:07:05	0.000	0.03