

P 274 010 420

RECEIPT FOR CERTIFIED MAIL

NO INSURANCE COVERAGE PROVIDED  
NOT FOR INTERNATIONAL MAIL  
(See Reverse)

\* U.S.G.P.O. 1985-480-794  
PS Form 3800, June 1985

Sent to Mr. J. R. Kolanek, Harris Corp	
Street and No. P.O. Box 883	
P.O., State and ZIP Code Melbourne, FL 32901	
Postage	\$
Certified Fee	
Special Delivery Fee	
Restricted Delivery Fee	
Return Receipt showing to whom and Date Delivered	
Return Receipt showing to whom, Date, and Address of Delivery	
TOTAL Postage and Fees	\$
Postmark or Date Mailed: 4-5-89 Permit: AC 05-157786, -87 -158237, -159489	

**SENDER:** Complete items 1 and 2 when additional services are desired, and complete items 3 and 4.  
Put your address in the "RETURN TO" Space on the reverse side. Failure to do this will prevent this card from being returned to you. The return receipt fee will provide you the name of the person delivered to and the date of delivery. For additional fees the following services are available. Consult postmaster for fees and check box(es) for additional service(s) requested.

1.  Show to whom delivered, date, and addressee's address. (Extra charge)    2.  Restricted Delivery (Extra charge)

3. Article Addressed to: Mr. J. R. Kolanek, Manager Environmental Services Harris Semiconductor P. O. Box 883 Melbourne, FL 32901	4. Article Number P 274 010 420 Type of Service: <input type="checkbox"/> Registered <input type="checkbox"/> Insured <input checked="" type="checkbox"/> Certified <input type="checkbox"/> COD <input type="checkbox"/> Express Mail <input type="checkbox"/> Return Receipt for Merchandise
5. Signature - Address <b>X</b>	Always obtain signature of addressee or agent and DATE DELIVERED.
6. Signature - Agent <b>X</b> <i>William F. Sawyer</i>	8. Addressee's Address (ONLY if requested and fee paid)
7. Date of Delivery <i>4/7/89</i>	

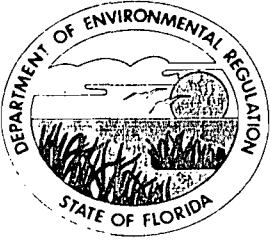

# Florida Department of Environmental Regulation

Twin Towers Office Bldg. • 2600 Blair Stone Road • Tallahassee, Florida 32399-2400

Bob Martinez, Governor

Dale Twachtman, Secretary

John Shearer, Assistant Secretary

STATE OF FLORIDA  
DEPARTMENT OF ENVIRONMENTAL REGULATION  
NOTICE OF PERMITS

Mr. J. R. Kolanek, Manager  
Environmental Services  
Harris Semiconductor  
P. O. Box 883  
Melbourne, Florida 32901

April 4, 1989

Enclosed are construction permits Nos. AC 05-157786, -157787, -158237, and -159482<sup>M</sup> for Harris Semiconductor to consolidate multiple permits previously issued for Building Nos. 51, 62, 63 and 58 at their facility in Palm Bay, Brevard County, Florida. These permits are issued pursuant to Section 403, Florida Statutes.

Any party to these permits has the right to seek judicial review of the permits pursuant to Section 120.68, Florida Statutes, by the filing of a Notice of Appeal pursuant to Rule 9.110, Florida Rules of Appellate Procedure, with the Clerk of the Department in the Office of General Counsel, 2600 Blair Stone Road, Tallahassee, Florida 32399-2400; and by filing a copy of the Notice of Appeal accompanied by the applicable filing fees with the appropriate District Court of Appeal. The Notice of Appeal must be filed within 30 days from the date these permits are filed with the Clerk of the Department.

Executed in Tallahassee, Florida.

STATE OF FLORIDA DEPARTMENT  
OF ENVIRONMENTAL REGULATION

C. H. Fancy, P.E.  
Deputy Chief  
Bureau of Air Quality Management

Copies furnished to:

C. Collins, CF District  
L. Hutker, Harris

CERTIFICATE OF SERVICE

The undersigned duly designated deputy clerk hereby certifies that this NOTICE OF PERMIT and all copies were mailed before the close of business on 4-5-89.

FILING AND ACKNOWLEDGEMENT  
FILED, on this date, pursuant to  
§120.52(9), Florida Statutes, with  
the designated Department Clerk,  
receipt of which is hereby  
acknowledged.

Martha Wise 4-5-89  
Clerk Date

**Final Determination**

**Harris Semiconductor  
Brevard County  
Palm Bay, Florida**

**Construction Permit Numbers:**

AC 05-157786

AC 05-157787

AC 05-158237

AC 05-159484

**Florida Department of Environmental Regulation  
Division of Air Resources Management  
Bureau of Air Quality Management  
Central Air Permitting**

**March 29, 1989**



**Final Determination**

**Harris Semiconductor  
Brevard County  
Palm Bay, Florida**

**Construction Permit Numbers:**

**AC 05-157786**

**AC 05-157787**

**AC 05-158237**

**AC 05-159484**

**Florida Department of Environmental Regulation  
Division of Air Resources Management  
Bureau of Air Quality Management  
Central Air Permitting**

**March 31, 1989**

## Final Determination

The four construction permit applications have been reviewed by the Department. Public Notice of the Department's Intent to Issue was published in the Florida Today Newspaper on March 4, 1989. The Technical Evaluation and Preliminary Determination (TE & PD) were available for public inspection at the DER's Central Florida District and Bureau of Air Quality Management offices.

Comments were received from Mr. J. R. Kolanek, Manager of Environmental Services - Harris Semiconductor. The Bureau's responses, which are in the same order as the comments (Items), are as follows:

1. Response to Item 1: TE & PD

- o The omission of the word "not" was an error and is acknowledged. Since it was used in a descriptive nature and does not affect the Department's review and "Intent to Issue," the TE & PD will not be reissued.

2. Response to Item 2: AC 05-157786, -157787, -158237, and -159484

- o The Bureau will agree to the following change:

Specific Condition

No. 6.a):

From: "a sample shall be taken annually from each scrubber stack and analyzed using EPA Reference Method 25;"

To: "a sample shall be taken annually from each scrubber stack and analyzed using EPA Reference Method 25 or, with Department approval, EPA Reference Method 25A, 40 CFR 60, Appendix A;"

3. Response to Item 3:

- o Since the U.S. EPA's current policy on the maximum allowable time frame to assess actual pollutant emissions from a source is 30 days, the Bureau cannot approve of any time frame in excess of that. This is why the annual material balance scheme is to be verifiable on a monthly basis and was imposed in Specific Condition No. 6. Therefore, no change will be made.

- o Because the approximate efficiencies of the control equipment have been established and calculated through tests and analysis, it would not be necessary to repeat this annually unless some operation or production process parameter changes. Consequently, the inlet concentration, if needed, can be estimated by knowing the outlet concentration and the penetration (1-efficiency), which is known from previous measurements. Therefore, actual pollutant emissions established from performance testing the outlet stream is in agreement with the reference test method(s). No change is necessary.

Attachment to be Incorporated:

- o AC 05-157786, -157787, -158237, and -159484
- 3. Mr. J. R. Kolanek's letter received March 1, 1989.

The Bureau will incorporate the changes in the appropriate construction permits, as referenced above in the final determination. It is recommended that the construction permits be issued as drafted, with the above revisions and attachments incorporated.



# Florida Department of Environmental Regulation

Twin Towers Office Bldg. • 2600 Blair Stone Road • Tallahassee, Florida 32399-2400

Bob Martinez, Governor

Dale Twachtman, Secretary

John Shearer, Assistant Secretary

## PERMITTEE:

Harris Semiconductor  
P. O. Box 883  
Melbourne, Florida 32901

Permit Number: AC 05-157786

Expiration Date: April 30, 1990

County: Brevard

Latitude/Longitude: 28° 01' 20" N  
80° 36' 10" W

Project: Building 51

This permit is issued under the provisions of Chapter 403, Florida Statutes, and Florida Administrative Code (F.A.C.) Rules 17-2 and 17-4. The above named permittee is hereby authorized to perform the work or operate the facility shown on the application and approved drawing(s), plans, and other documents attached hereto or on file with the Department and made a part hereof and specifically described as follows:

For the permitting of Building 51, a wafer fabrication source, of which there are two clean room modules. The scrubber control systems are:

- o F51S01: a Tri Mer Corp. 9,500 scfm horizontal counter-flow fume scrubber using polypropylene packing for acid gas removal; Model No. F/W 3;
- o F51S02: a Duall Ind. 10,000 scfm horizontal cross-flow fume scrubber using polypropylene packing for VOC/solvent removal; Model No. F-101;
- o F51S03: a Duall Ind. 24,000 scfm horizontal cross-flow fume scrubber using polypropylene packing for acid gas and VOC/solvent removal; Model No. F-101;
- o F51S04: the same as F51S03; and,
- o F51S05: a Harrison 18,000 scfm horizontal cross-flow fume scrubber using plastic saddle packing for VOC/solvent removal; Model No. HF-180.

The building/source is located at the permittee's existing facility located on Palm Bay Road in the City of Palm Bay. The UTM coordinates are Zone 17, 538.7 km East and 3100.9 km North.

The Source Classification Codes are: Major Group 36

- o Cold Solvent Cleaning/ 4-01-003-99 Tons VOC/solvent  
Stripping ~~consumed~~ Consumed

The source shall be in accordance with the permit application and plans, documents, amendments, and drawings except as otherwise noted in the General and Specific Conditions.

Attachments to be Incorporated:

1. Application to Construct Air Pollution Sources, DER Form 17-1.202(1), and Mr. James R. Kolanek's cover letter received November 28, 1988.
2. Technical Evaluation and Preliminary Determination dated February 3, 1989.
3. Mr. J. R. Kolanek's letter received March 1, 1989.

**PERMITTEE:**  
Harris Semiconductor

**Permit Number:** AC 05-157786  
**Expiration Date:** April 30, 1990

**GENERAL CONDITIONS:**

1. The terms, conditions, requirements, limitations, and restrictions set forth herein are "Permit Conditions" and as such are binding upon the permittee and enforceable pursuant to the authority of Sections 403.161, 403.727, or 403.859 through 403.861, Florida Statutes. The permittee is hereby placed on notice that the Department will review this permit periodically and may initiate enforcement action for any violation of the "Permit Conditions" by the permittee, its agents, employees, servants or representatives.

2. This permit is valid only for the specific processes and operations applied for and indicated in the approved drawings or exhibits. Any unauthorized deviation from the approved drawings, exhibits, specifications, or conditions of this permit may constitute grounds for revocation and enforcement action by the Department.

3. As provided in Subsections 403.087(6) and 403.722(5), Florida Statutes, the issuance of this permit does not convey any vested rights or any exclusive privileges. Nor does it authorize any injury to public or private property or any invasion of personal rights, nor any infringement of federal, state or local laws or regulations. This permit does not constitute a waiver of or approval of any other Department permit that may be required for other aspects of the total project which are not addressed in the permit.

4. This permit conveys no title to land or water, does not constitute state recognition or acknowledgement of title, and does not constitute authority for the use of submerged lands unless herein provided and the necessary title or leasehold interests have been obtained from the state. Only the Trustees of the Internal Improvement Trust Fund may express state opinion as to title.

5. This permit does not relieve the permittee from liability for harm or injury to human health or welfare, animal, plant or aquatic life or property and penalties therefore caused by the construction or operation of this permitted source, nor does it allow the permittee to cause pollution in contravention of Florida Statutes and Department rules, unless specifically authorized by an order from the Department.

**PERMITTEE:**  
**Harris Semiconductor**

**Permit Number: AC 05-157786**  
**Expiration Date: April 30, 1990**

**GENERAL CONDITIONS:**

6. The permittee shall at all times properly operate and maintain the facility and systems of treatment and control (and related appurtenances) that are installed or used by the permittee to achieve compliance with the conditions of this permit, as required by Department rules. This provision includes the operation of backup or auxiliary facilities or similar systems when necessary to achieve compliance with the conditions of the permit and when required by Department rules.

7. The permittee, by accepting this permit, specifically agrees to allow authorized Department personnel, upon presentation of credentials or other documents as may be required by law, access to the premises, at reasonable times, where the permitted activity is located or conducted for the purpose of:

- a. Having access to and copying any records that must be kept under the conditions of the permit;
- b. Inspecting the facility, equipment, practices, or operations regulated or required under this permit; and
- c. Sampling or monitoring any substances or parameters at any location reasonably necessary to assure compliance with this permit or Department rules.

Reasonable time may depend on the nature of the concern being investigated.

8. If, for any reason, the permittee does not comply with or will be unable to comply with any condition or limitation specified in this permit, the permittee shall immediately notify and provide the Department with the following information:

- a. a description of and cause of non-compliance; and
- b. the period of noncompliance, including exact dates and times; or, if not corrected, the anticipated time the noncompliance is expected to continue, and steps being taken to reduce, eliminate, and prevent recurrence of the noncompliance.

PERMITTEE:  
Harris Semiconductor

Permit Number: AC 05-157786  
Expiration Date: April 30, 1990

**GENERAL CONDITIONS:**

The permittee shall be responsible for any and all damages which may result and may be subject to enforcement action by the Department for penalties or revocation of this permit.

9. In accepting this permit, the permittee understands and agrees that all records, notes, monitoring data and other information relating to the construction or operation of this permitted source, which are submitted to the Department, may be used by the Department as evidence in any enforcement case arising under the Florida Statutes or Department rules, except where such use is proscribed by Sections 403.73 and 403.111, Florida Statutes.

10. The permittee agrees to comply with changes in Department rules and Florida Statutes after a reasonable time for compliance, provided however, the permittee does not waive any other rights granted by Florida Statutes or Department rules.

11. This permit is transferable only upon Department approval in accordance with Florida Administrative Code Rules 17-4.12 and 17-30.30, as applicable. The permittee shall be liable for any noncompliance of the permitted activity until the transfer is approved by the Department.

12. This permit is required to be kept at the work site of the permitted activity during the entire period of construction or operation.

13. This permit also constitutes:

- ( ) Determination of Best Available Control Technology (BACT)
- ( ) Determination of Prevention of Significant Deterioration (PSD).
- ( ) Compliance with New Source Performance Standards.

14. The permittee shall comply with the following monitoring and record keeping requirements:

- a. Upon request, the permittee shall furnish all records and plans required under department rules. The retention period for all records will be extended automatically, unless otherwise stipulated by the Department, during the course of any unresolved enforcement action.

**PERMITTEE:**  
Harris Semiconductor

**Permit Number:** AC 05-157786  
**Expiration Date:** April 30, 1990

**GENERAL CONDITIONS:**

b. The permittee shall retain at the facility or other location designated by this permit records of all monitoring information (including all calibration and maintenance records and all original strip chart recordings for continuous monitoring instrumentation), copies of all reports required by this permit, and records of all data used to complete the application for this permit. The time period of retention shall be at least three years from the date of the sample, measurement, report or application unless otherwise specified by Department rule.

c. Records of monitoring information shall include:

- the date, exact place, and time of sampling or measurements;
- the person responsible for performing the sampling or measurements;
- the date(s) analyses were performed;
- the person responsible for performing the analyses;
- the analytical techniques or methods used; and
- the results of such analyses.

15. When requested by the Department, the permittee shall within a reasonable time furnish any information required by law which is needed to determine compliance with the permit. If the permittee becomes aware that relevant facts were not submitted or were incorrect in the permit application or in any report to the Department, such facts or information shall be submitted or corrected promptly.

**SPECIFIC CONDITIONS:**

1. The maximum allowable VOC/solvent emissions from Building No. 51 shall be 33.3 tons per year.

2. The VOC/solvent vapor exhaust scrubber must be on during the working hours.

3. Annual operation shall be 8760 hours per year.

4. Objectionable odors shall not be allowed off plant property.



PERMITTEE:  
Harris Semiconductor

Permit Number: AC 05-157786  
Expiration Date: April 30, 1990

**SPECIFIC CONDITIONS:**

5. An inspection and maintenance plan shall be submitted to the DER's Central Florida District office as part of the operating permit application. The plan shall include provisions for the prevention and correction of VOC/solvent losses from leaks and equipment malfunctions.

6. By March 31 of each calendar year, an annual operating report shall be submitted to the DER's Central Florida District office demonstrating compliance with the VOC/solvent emissions limit for Building No. 51. The emissions shall be determined by a material balance scheme, verifiable on a monthly basis, and shall include the following:

- a) a beginning inventory of full containers, cylinders and storage tanks at the beginning of each calendar year;
- b) plus all purchased deliveries after the beginning inventory (verifiable by invoices);
- c) minus all quantities picked-up and shipped-off the premise after the beginning inventory (verifiable by invoices);
- d) minus all quantities deep well injected during the calendar year, justified by assumptions and established scrubber efficiencies; and,
- e) minus an ending inventory of full containers, cylinders, and storage tanks; and, should occur at the beginning of the following calendar year.

7. Each scrubber system's efficiency and potential VOC/solvent emissions shall be established by a sampling and analysis program, which includes:

- a) a sample shall be taken annually from each scrubber stack and analyzed using EPA Reference Method 25 or, with Department approval, EPA Reference Method 25A, 40 CFR 60, Appendix A;
- b) the DER's Central Florida District office shall receive 15 days notice in writing prior to sampling; and,
- c) the report, summarizing the sampling results, shall be submitted to the DER's Central Florida District office within 45 days after the last test run is completed.

8. This permit will supercede all other permits previously issued on this source/Building No. 51.

9. The source/Building No. 51 is subject to all applicable provisions of F.A.C. Chapters 17-2 and 17-4.

10. Projected potential acid emissions are 3.7 TPY.

PERMITTEE:  
Harris Semiconductor

Permit Number: AC 05-157786  
Expiration Number: April 30, 1990

**SPECIFIC CONDITIONS:**

11. Building No. 51 is subject to the provisions of F.A.C. Rules 17-2.240: Circumvention; 17-2.250: Excess Emissions; and, 17-4.130: Plant Operation - Problems.

12. Any modification pursuant to F.A.C. Rule 17-2.100(119), Modification, shall be submitted to the DER's Central Florida District office and the Bureau of Air Quality Management office for approval.

13. The permittee, for good cause, may request that this construction permit be extended. Such a request shall be submitted to the BAQM prior to 60 days before the expiration of the permit (F.A.C. Rule 17-4.090).

14. An application for an operation permit must be submitted to the Central Florida District office at least 90 days prior to the expiration date of this construction permit or within 45 days after completion of compliance testing, whichever comes first. To properly apply for an operation permit, the applicant shall submit the appropriate application form, fee, certification that construction was completed noting any deviations from the conditions in the construction permit, and compliance test reports as required by this permit (F.A.C. Rule 17-4.220).

Issued this 31 day of March,  
1989

STATE OF FLORIDA DEPARTMENT  
OF ENVIRONMENTAL REGULATION

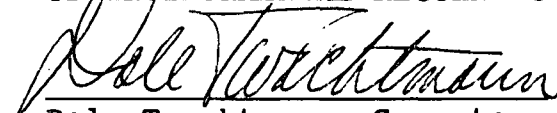
  
Dale Twachtmann, Secretary



## Florida Department of Environmental Regulation

Twin Towers Office Bldg. • 2600 Blair Stone Road • Tallahassee, Florida 32399-2400

Bob Martinez, Governor

Dale Twachtmann, Secretary

John Shearer, Assistant Secretary

**PERMITTEE:**

Harris Semiconductor  
P. O. Box 883  
Melbourne, Florida 32901

Permit Number: AC 05-157787

Expiration Date: April 30, 1990

County: Brevard

Latitude/Longitude: 28° 01' 20" N  
80° 36' 10" W

Project: Building 62

This permit is issued under the provisions of Chapter 403, Florida Statutes, and Florida Administrative Code (F.A.C.) Rules 17-2 and 17-4. The above named permittee is hereby authorized to perform the work or operate the facility shown on the application and approved drawing(s), plans, and other documents attached hereto or on file with the Department and made a part hereof and specifically described as follows:

For the permitting of Building 62, which houses a research and development laboratory, a prototype wafer fabrication process, and an analytical services laboratory. The scrubber control systems are:

- o F62S01: a Beverly Pacific 24,000 scfm horizontal cross-flow vapor scrubber using polypropylene packing for acid gas removal; Model No. PS-24T; and,
- o F62S02: a Beverly Pacific 12,000 scfm vertical counter-current vapor scrubber using polypropylene packing for VOC/solvent removal; Model No. PS-12VT.

The building/source is located at the permittee's existing facility located on Palm Bay Road in the City of Palm Bay. The UTM coordinates are Zone 17, 538.7 km East and 3100.9 km North.

The Source Classification Codes are: Major Group 36

- o Cold Solvent Cleaning/ 4-01-003-99 Tons VOC/solvent Stripping consumed

The source shall be in accordance with the permit application and plans, documents, amendments, and drawings except as otherwise noted in the General and Specific Conditions.

**Attachments to be Incorporated:**

1. Application to Construct Air Pollution Sources, DER Form 17-1.202(1), and Mr. James R. Kolanek's cover letter received November 28, 1988.
2. Technical Evaluation and Preliminary Determination dated February 3, 1989.
3. Mr. J. R. Kolanek's letter received March 1, 1989.

**PERMITTEE:**  
Harris Semiconductor

Permit Number: AC 05-157787  
Expiration Date: April 30, 1990

**GENERAL CONDITIONS:**

1. The terms, conditions, requirements, limitations, and restrictions set forth herein are "Permit Conditions" and as such are binding upon the permittee and enforceable pursuant to the authority of Sections 403.161, 403.727, or 403.859 through 403.861, Florida Statutes. The permittee is hereby placed on notice that the Department will review this permit periodically and may initiate enforcement action for any violation of the "Permit Conditions" by the permittee, its agents, employees, servants or representatives.

2. This permit is valid only for the specific processes and operations applied for and indicated in the approved drawings or exhibits. Any unauthorized deviation from the approved drawings, exhibits, specifications, or conditions of this permit may constitute grounds for revocation and enforcement action by the Department.

3. As provided in Subsections 403.087(6) and 403.722(5), Florida Statutes, the issuance of this permit does not convey any vested rights or any exclusive privileges. Nor does it authorize any injury to public or private property or any invasion of personal rights, nor any infringement of federal, state or local laws or regulations. This permit does not constitute a waiver of or approval of any other Department permit that may be required for other aspects of the total project which are not addressed in the permit.

4. This permit conveys no title to land or water, does not constitute state recognition or acknowledgement of title, and does not constitute authority for the use of submerged lands unless herein provided and the necessary title or leasehold interests have been obtained from the state. Only the Trustees of the Internal Improvement Trust Fund may express state opinion as to title.

5. This permit does not relieve the permittee from liability for harm or injury to human health or welfare, animal, plant or aquatic life or property and penalties therefore caused by the construction or operation of this permitted source, nor does it allow the permittee to cause pollution in contravention of Florida Statutes and Department rules, unless specifically authorized by an order from the Department.

**PERMITTEE:**  
Harris Semiconductor

Permit Number: AC 05-157787  
Expiration Date: April 30, 1990

**GENERAL CONDITIONS:**

6. The permittee shall at all times properly operate and maintain the facility and systems of treatment and control (and related appurtenances) that are installed or used by the permittee to achieve compliance with the conditions of this permit, as required by Department rules. This provision includes the operation of backup or auxiliary facilities or similar systems when necessary to achieve compliance with the conditions of the permit and when required by Department rules.

7. The permittee, by accepting this permit, specifically agrees to allow authorized Department personnel, upon presentation of credentials or other documents as may be required by law, access to the premises, at reasonable times, where the permitted activity is located or conducted for the purpose of:

- a. Having access to and copying any records that must be kept under the conditions of the permit;
- b. Inspecting the facility, equipment, practices, or operations regulated or required under this permit; and
- c. Sampling or monitoring any substances or parameters at any location reasonably necessary to assure compliance with this permit or Department rules.

Reasonable time may depend on the nature of the concern being investigated.

8. If, for any reason, the permittee does not comply with or will be unable to comply with any condition or limitation specified in this permit, the permittee shall immediately notify and provide the Department with the following information:

- a. a description of and cause of non-compliance; and
- b. the period of noncompliance, including exact dates and times; or, if not corrected, the anticipated time the noncompliance is expected to continue, and steps being taken to reduce, eliminate, and prevent recurrence of the noncompliance.

**PERMITTEE:**  
**Harris Semiconductor**

**Permit Number: AC 05-157787**  
**Expiration Date: April 30, 1990**

**GENERAL CONDITIONS:**

The permittee shall be responsible for any and all damages which may result and may be subject to enforcement action by the Department for penalties or revocation of this permit.

9. In accepting this permit, the permittee understands and agrees that all records, notes, monitoring data and other information relating to the construction or operation of this permitted source, which are submitted to the Department, may be used by the Department as evidence in any enforcement case arising under the Florida Statutes or Department rules, except where such use is proscribed by Sections 403.73 and 403.111, Florida Statutes.

10. The permittee agrees to comply with changes in Department rules and Florida Statutes after a reasonable time for compliance, provided however, the permittee does not waive any other rights granted by Florida Statutes or Department rules.

11. This permit is transferable only upon Department approval in accordance with Florida Administrative Code Rules 17-4.12 and 17-30.30, as applicable. The permittee shall be liable for any noncompliance of the permitted activity until the transfer is approved by the Department.

12. This permit is required to be kept at the work site of the permitted activity during the entire period of construction or operation.

13. This permit also constitutes:

- ( ) Determination of Best Available Control Technology (BACT)
- ( ) Determination of Prevention of Significant Deterioration (PSD).
- ( ) Compliance with New Source Performance Standards.

14. The permittee shall comply with the following monitoring and record keeping requirements:

- a. Upon request, the permittee shall furnish all records and plans required under department rules. The retention period for all records will be extended automatically, unless otherwise stipulated by the Department, during the course of any unresolved enforcement action.

**PERMITTEE:**  
**Harris Semiconductor**

**Permit Number: AC 05-157787**  
**Expiration Date: April 30, 1990**

**GENERAL CONDITIONS:**

b. The permittee shall retain at the facility or other location designated by this permit records of all monitoring information (including all calibration and maintenance records and all original strip chart recordings for continuous monitoring instrumentation), copies of all reports required by this permit, and records of all data used to complete the application for this permit. The time period of retention shall be at least three years from the date of the sample, measurement, report or application unless otherwise specified by Department rule.

c. Records of monitoring information shall include:

- the date, exact place, and time of sampling or measurements;
- the person responsible for performing the sampling or measurements;
- the date(s) analyses were performed;
- the person responsible for performing the analyses;
- the analytical techniques or methods used; and
- the results of such analyses.

15. When requested by the Department, the permittee shall within a reasonable time furnish any information required by law which is needed to determine compliance with the permit. If the permittee becomes aware that relevant facts were not submitted or were incorrect in the permit application or in any report to the Department, such facts or information shall be submitted or corrected promptly.

**SPECIFIC CONDITIONS:**

1. The maximum allowable VOC/solvent emissions from Building No. 62 shall be 0.8 tons per year.

2. The VOC/solvent vapor exhaust scrubber must be on during the working hours.

3. Annual operation shall be 8760 hours per year.

4. Objectionable odors shall not be allowed off plant property.

PERMITTEE:  
Harris Semiconductor

Permit Number: AC 05-157787  
Expiration Date: April 30, 1990

**SPECIFIC CONDITIONS:**

5. An inspection and maintenance plan shall be submitted to the DER's Central Florida District office as part of the operating permit application. The plan shall include provisions for the prevention and correction of VOC/solvent losses from leaks and equipment malfunctions.

6. By March 31 of each calendar year, an annual operating report shall be submitted to the DER's Central Florida District office demonstrating compliance with the VOC/solvent emissions limit for Building No. 62. The emissions shall be determined by a material balance scheme, verifiable on a monthly basis, and shall include the following:

- a) a beginning inventory of full containers, cylinders and storage tanks at the beginning of each calendar year;
- b) plus all purchased deliveries after the beginning inventory (verifiable by invoices);
- c) minus all quantities picked-up and shipped-off the premise after the beginning inventory (verifiable by invoices);
- d) minus all quantities deep well injected during the calendar year, justified by assumptions and established scrubber efficiencies; and,
- e) minus an ending inventory of full containers, cylinders, and storage tanks; and, should occur at the beginning of the following calendar year.

7. Each scrubber system's efficiency and potential VOC/solvent emissions shall be established by a sampling and analysis program, which includes:

- a) a sample shall be taken annually from each scrubber stack and analyzed using EPA Reference Method 25 or, with Department approval, EPA Reference Method 25A, 40 CFR 60, Appendix A;
- b) the DER's Central Florida District office shall receive 15 days notice in writing prior to sampling; and,
- c) the report, summarizing the sampling results, shall be submitted to the DER's Central Florida District office within 45 days after the last test run is completed.

8. This permit will supercede all other permits previously issued on this source/Building No. 62.

9. The source/Building No. 62 is subject to all applicable provisions of F.A.C. Chapters 17-2 and 17-4.

10. Projected potential acid emissions are 0.2 TPY.



PERMITTEE:  
Harris Semiconductor

Permit Number: AC 05-157787  
Expiration Number: April 30, 1990

SPECIFIC CONDITIONS:

11. Building No. 62 is subject to the provisions of F.A.C. Rules 17-2.240: Circumvention; 17-2.250: Excess Emissions; and, 17-4.130: Plant Operation - Problems.

12. Any modification pursuant to F.A.C. Rule 17-2.100(119), Modification, shall be submitted to the DER's Central Florida District office and the Bureau of Air Quality Management office for approval.

13. The permittee shall, for good cause, may request that this construction permit be extended. Such a request shall be submitted to the BAQM prior to 60 days before the expiration of the permit (F.A.C. Rule 17-4.090).

14. An application for an operation permit must be submitted to the Central Florida District office at least 90 days prior to the expiration date of this construction permit or within 45 days after completion of compliance testing, whichever occurs first. To properly apply for an operation permit, the applicant shall submit the appropriate application form, fee, certification that construction was completed noting any deviations from the conditions in the construction permit, and compliance test reports as required by this permit (F.A.C. Rule 17-4.220).

Issued this 31 day of March,  
1989

STATE OF FLORIDA DEPARTMENT  
OF ENVIRONMENTAL REGULATION

  
Dale Twachtmann, Secretary



# Florida Department of Environmental Regulation

Twin Towers Office Bldg. • 2600 Blair Stone Road • Tallahassee, Florida 32399-2400

Bob Martinez, Governor

Dale Twachtmann, Secretary

John Shearer, Assistant Secretary

**PERMITTEE:**  
Harris Semiconductor  
P. O. Box 883  
Melbourne, Florida 32901

Permit Number: AC 05-158237  
Expiration Date: April 30, 1990  
County: Brevard  
Latitude/Longitude: 28° 01' 20" N  
80° 36' 10" W  
Project: Building 63

This permit is issued under the provisions of Chapter 403, Florida Statutes, and Florida Administrative Code (F.A.C.) Rules 17-2 and 17-4. The above named permittee is hereby authorized to perform the work or operate the facility shown on the application and approved drawing(s), plans, and other documents attached hereto or on file with the Department and made a part hereof and specifically described as follows:

For the permitting of Building 63, which is a wafer fabrication and assembly source. The scrubber control systems are:

- o F63SO1: a Beverly Pacific 50,000 scfm horizontal cross-flow scrubber vapor using polypropylene packing for acid gas removal; Model No. CB-60;
- o F63SO2: a Beverly Pacific 10,000 scfm vertical counter-current vapor scrubber using polypropylene packing for VOC/solvent removal; Model No. PS-12VT; and,
- o F63SO3: a Tri Mer Corp. 6,000 scfm horizontal counter-flow fume scrubber using polypropylene packing for VOC/solvent removal; Model No. F/WR-5.

The building/source is located at the permittee's existing facility located on Palm Bay Road in the City of Palm Bay. The UTM coordinates are Zone 17, 538.7 km East and 3100.9 km North.

The Source Classification Codes are: Major Group 36

- o Cold Solvent Cleaning/ 4-01-003-99 Tons VOC/solvent Stripping consumed

The source shall be in accordance with the permit application and plans, documents, amendments, and drawings except as otherwise noted in the General and Specific Conditions.

Attachments to be Incorporated:

1. Application to Construct Air Pollution Sources, DER Form 17-1.202(1), and Mr. James R. Kolanek's cover letter received December 9, 1988.
2. Technical Evaluation and Preliminary Determination dated February 3, 1989.
3. Mr. J. R. Kolanek's letter received March 1, 1989.

PERMITTEE  
Harris Semiconductor

Permit Number: AC 05-158237  
Expiration Date: April 30, 1990

**GENERAL CONDITIONS:**

1. The terms, conditions, requirements, limitations, and restrictions set forth herein are "Permit Conditions" and as such are binding upon the permittee and enforceable pursuant to the authority of Sections 403.161, 403.727, or 403.859 through 403.861, Florida Statutes. The permittee is hereby placed on notice that the Department will review this permit periodically and may initiate enforcement action for any violation of the "Permit Conditions" by the permittee, its agents, employees, servants or representatives.

2. This permit is valid only for the specific processes and operations applied for and indicated in the approved drawings or exhibits. Any unauthorized deviation from the approved drawings, exhibits, specifications, or conditions of this permit may constitute grounds for revocation and enforcement action by the Department.

3. As provided in Subsections 403.087(6) and 403.722(5), Florida Statutes, the issuance of this permit does not convey any vested rights or any exclusive privileges. Nor does it authorize any injury to public or private property or any invasion of personal rights, nor any infringement of federal, state or local laws or regulations. This permit does not constitute a waiver of or approval of any other Department permit that may be required for other aspects of the total project which are not addressed in the permit.

4. This permit conveys no title to land or water, does not constitute state recognition or acknowledgement of title, and does not constitute authority for the use of submerged lands unless herein provided and the necessary title or leasehold interests have been obtained from the state. Only the Trustees of the Internal Improvement Trust Fund may express state opinion as to title.

5. This permit does not relieve the permittee from liability for harm or injury to human health or welfare, animal, plant or aquatic life or property and penalties therefore caused by the construction or operation of this permitted source, nor does it allow the permittee to cause pollution in contravention of Florida Statutes and Department rules, unless specifically authorized by an order from the Department.

PERMITTEE:  
Harris Semiconductor

Permit Number: AC 05-158237  
Expiration Date: April 30, 1990

**GENERAL CONDITIONS:**

6. The permittee shall at all times properly operate and maintain the facility and systems of treatment and control (and related appurtenances) that are installed or used by the permittee to achieve compliance with the conditions of this permit, as required by Department rules. This provision includes the operation of backup or auxiliary facilities or similar systems when necessary to achieve compliance with the conditions of the permit and when required by Department rules.

7. The permittee, by accepting this permit, specifically agrees to allow authorized Department personnel, upon presentation of credentials or other documents as may be required by law, access to the premises, at reasonable times, where the permitted activity is located or conducted for the purpose of:

- a. Having access to and copying any records that must be kept under the conditions of the permit;
- b. Inspecting the facility, equipment, practices, or operations regulated or required under this permit; and
- c. Sampling or monitoring any substances or parameters at any location reasonably necessary to assure compliance with this permit or Department rules.

Reasonable time may depend on the nature of the concern being investigated.

8. If, for any reason, the permittee does not comply with or will be unable to comply with any condition or limitation specified in this permit, the permittee shall immediately notify and provide the Department with the following information:

- a. a description of and cause of non-compliance; and
- b. the period of noncompliance, including exact dates and times; or, if not corrected, the anticipated time the noncompliance is expected to continue, and steps being taken to reduce, eliminate, and prevent recurrence of the noncompliance.

PERMITTEE:  
Harris Semiconductor

Permit Number: AC 05-158237  
Expiration Date: April 30, 1990

**GENERAL CONDITIONS:**

The permittee shall be responsible for any and all damages which may result and may be subject to enforcement action by the Department for penalties or revocation of this permit.

9. In accepting this permit, the permittee understands and agrees that all records, notes, monitoring data and other information relating to the construction or operation of this permitted source, which are submitted to the Department, may be used by the Department as evidence in any enforcement case arising under the Florida Statutes or Department rules, except where such use is proscribed by Sections 403.73 and 403.111, Florida Statutes.

10. The permittee agrees to comply with changes in Department rules and Florida Statutes after a reasonable time for compliance, provided however, the permittee does not waive any other rights granted by Florida Statutes or Department rules.

11. This permit is transferable only upon Department approval in accordance with Florida Administrative Code Rules 17-4.12 and 17-30.30, as applicable. The permittee shall be liable for any noncompliance of the permitted activity until the transfer is approved by the Department.

12. This permit is required to be kept at the work site of the permitted activity during the entire period of construction or operation.

13. This permit also constitutes:

- ( ) Determination of Best Available Control Technology (BACT)
- ( ) Determination of Prevention of Significant Deterioration (PSD).
- ( ) Compliance with New Source Performance Standards.

14. The permittee shall comply with the following monitoring and record keeping requirements:

- a. Upon request, the permittee shall furnish all records and plans required under department rules. The retention period for all records will be extended automatically, unless otherwise stipulated by the Department, during the course of any unresolved enforcement action.

**PERMITTEE:**  
Harris Semiconductor

Permit Number: AC 05-158237  
Expiration Date: April 30, 1990

**GENERAL CONDITIONS:**

b. The permittee shall retain at the facility or other location designated by this permit records of all monitoring information (including all calibration and maintenance records and all original strip chart recordings for continuous monitoring instrumentation), copies of all reports required by this permit, and records of all data used to complete the application for this permit. The time period of retention shall be at least three years from the date of the sample, measurement, report or application unless otherwise specified by Department rule.

c. Records of monitoring information shall include:

- the date, exact place, and time of sampling or measurements;
- the person responsible for performing the sampling or measurements;
- the date(s) analyses were performed;
- the person responsible for performing the analyses;
- the analytical techniques or methods used; and
- the results of such analyses.

15. When requested by the Department, the permittee shall within a reasonable time furnish any information required by law which is needed to determine compliance with the permit. If the permittee becomes aware that relevant facts were not submitted or were incorrect in the permit application or in any report to the Department, such facts or information shall be submitted or corrected promptly.

**SPECIFIC CONDITIONS:**

1. The maximum allowable VOC/solvent emissions from Building No. 63 shall be 6.1 tons per year.
2. The VOC/solvent vapor exhaust scrubber must be on during the working hours.
3. Annual operation shall be 8760 hours per year.
4. Objectionable odors shall not be allowed off plant property.

PERMITTEE:  
Harris Semiconductor

Permit Number: AC 05-158237  
Expiration Date: April 30, 1990

**SPECIFIC CONDITIONS:**

5. An inspection and maintenance plan shall be submitted to the DER's Central Florida District office as part of the operating permit application. The plan shall include provisions for the prevention and correction of VOC/solvent losses from leaks and equipment malfunctions.

6. By March 31 of each calendar year, an annual operating report shall be submitted to the DER's Central Florida District office demonstrating compliance with the VOC/solvent emissions limit for Building No. 63. The emissions shall be determined by a material balance scheme, verifiable on a monthly basis, and shall include the following:

- a) a beginning inventory of full containers, cylinders and storage tanks at the beginning of each calendar year;
- b) plus all purchased deliveries after the beginning inventory (verifiable by invoices);
- c) minus all quantities picked-up and shipped-off the premise after the beginning inventory (verifiable by invoices);
- d) minus all quantities deep well injected during the calendar year, justified by assumptions and established scrubber efficiencies; and,
- e) minus an ending inventory of full containers, cylinders, and storage tanks; and, should occur at the beginning of the following calendar year.

7. Each scrubber system's efficiency and potential VOC/solvent emissions shall be established by a sampling and analysis program, which includes:

- a) a sample shall be taken annually from each scrubber stack and analyzed using EPA Reference Method 25 or, with Department approval, EPA Reference Method 25A, 40 CFR 60, Appendix A;
- b) the DER's Central Florida District office shall receive 15 days notice in writing prior to sampling; and,
- c) the report, summarizing the sampling results, shall be submitted to the DER's Central Florida District office within 45 days after the last test run is completed.

8. This permit will supercede all other permits previously issued on this source/Building No. 63.

9. The source/Building No. 63 is subject to all applicable provisions of F.A.C. Chapters 17-2 and 17-4.

10. Projected potential acid emissions are 0.2 TPY.

PERMITTEE:  
Harris Semiconductor

Permit Number: AC 05-158237  
Expiration Number: April 30, 1990

**SPECIFIC CONDITIONS:**

11. Building No. 63 is subject to the provisions of F.A.C. Rules 17-2.240: Circumvention; 17-2.250: Excess Emissions; and, 17-4.130: Plant Operation - Problems.

12. Any modification pursuant to F.A.C. Rule 17-2.100(119), Modification, shall be submitted to the DER's Central Florida District office and the Bureau of Air Quality Management office for approval.

13. The permittee, for good cause, may request that this construction permit be extended. Such a request shall be submitted to the BAQM prior to 60 days before the expiration of the permit (F.A.C. Rule 17-4.090).

14. An application for an operation permit must be submitted to the Central Florida District office at least 90 days prior to the expiration date of this construction permit or within 45 days after completion of compliance testing, whichever comes first. To properly apply for an operation permit, the applicant shall submit the appropriate application form, fee, certification that construction was completed noting any deviations from the conditions in the construction permit, and compliance test reports as required by this permit (F.A.C. Rule 17-4.220).

Issued this 31 day of March,  
1989

STATE OF FLORIDA DEPARTMENT  
OF ENVIRONMENTAL REGULATION

  
Dale Twachtman, Secretary





## Florida Department of Environmental Regulation

Twin Towers Office Bldg. • 2600 Blair Stone Road • Tallahassee, Florida 32399-2400

Bob Martinez, Governor

Dale Twachtman, Secretary

John Shearer, Assistant Secretary

**PERMITTEE:**  
Harris Semiconductor  
P. O. Box 883  
Melbourne, Florida 32901

Permit Number: AC 05-159484  
Expiration Date: April 30, 1990  
County: Brevard  
Latitude/Longitude: 28° 01' 20" N  
80° 36' 10" W

Project: Building 58

This permit is issued under the provisions of Chapter 403, Florida Statutes, and Florida Administrative Code (F.A.C.) Rules 17-2 and 17-4. The above named permittee is hereby authorized to perform the work or operate the facility shown on the application and approved drawing(s), plans, and other documents attached hereto or on file with the Department and made a part hereof and specifically described as follows:

For the permitting of Building 58, which is a source whose primary manufacturing operations are assembly and testing of integrated circuits. The scrubber control systems and dust collector system are:

- o F58S01: a Tri Mer Corp. 12,500 scfm horizontal counter-flow vapor scrubber using polypropylene packing for caustic and corrosive vapor removal; Model No. F/W 5;
- o F58S02: a Harrison 3,000 scfm horizontal cross-flow vapor scrubber using plastic saddle packing for VOC/solvent removal; Model No. HF-30; and,
- o F58E01: a Torit 3,000 cfm filter cartridge dust collector with a pulse-jet cleaning cycle; Model No. TD 486.

The building/source is located at the permittee's existing facility located on Palm Bay Road in the City of Palm Bay. The UTM coordinates are Zone 17, 538.7 km East and 3100.9 km North.

The Source Classification Codes are: Major Group 36

- o Cold Solvent Cleaning/ 4-01-003-99 Tons VOC/solvent Stripping consumed

The source shall be in accordance with the permit application and plans, documents, amendments, and drawings except as otherwise noted in the General and Specific Conditions.

Attachments to be Incorporated:

1. Application to Construct Air Pollution Sources, DER Form 17-1.202(1), and Mr. James R. Kolanek's cover letter received January 17, 1989.
2. Technical Evaluation and Preliminary Determination dated February 3, 1989.
3. Mr. J. R. Kolanek's letter received March 1, 1989.

**PERMITTEE:**  
**Harris Semiconductor**

**Permit Number: AC 05-159484**  
**Expiration Date: April 30, 1990**

**GENERAL CONDITIONS:**

1. The terms, conditions, requirements, limitations, and restrictions set forth herein are "Permit Conditions" and as such are binding upon the permittee and enforceable pursuant to the authority of Sections 403.161, 403.727, or 403.859 through 403.861, Florida Statutes. The permittee is hereby placed on notice that the Department will review this permit periodically and may initiate enforcement action for any violation of the "Permit Conditions" by the permittee, its agents, employees, servants or representatives.

2. This permit is valid only for the specific processes and operations applied for and indicated in the approved drawings or exhibits. Any unauthorized deviation from the approved drawings, exhibits, specifications, or conditions of this permit may constitute grounds for revocation and enforcement action by the Department.

3. As provided in Subsections 403.087(6) and 403.722(5), Florida Statutes, the issuance of this permit does not convey any vested rights or any exclusive privileges. Nor does it authorize any injury to public or private property or any invasion of personal rights, nor any infringement of federal, state or local laws or regulations. This permit does not constitute a waiver of or approval of any other Department permit that may be required for other aspects of the total project which are not addressed in the permit.

4. This permit conveys no title to land or water, does not constitute state recognition or acknowledgement of title, and does not constitute authority for the use of submerged lands unless herein provided and the necessary title or leasehold interests have been obtained from the state. Only the Trustees of the Internal Improvement Trust Fund may express state opinion as to title.

5. This permit does not relieve the permittee from liability for harm or injury to human health or welfare, animal, plant or aquatic life or property and penalties therefore caused by the construction or operation of this permitted source, nor does it allow the permittee to cause pollution in contravention of Florida Statutes and Department rules, unless specifically authorized by an order from the Department.

PERMITTEE:  
Harris Semiconductor

Permit Number: AC 05-159484  
Expiration Date: April 30, 1990

**GENERAL CONDITIONS:**

6. The permittee shall at all times properly operate and maintain the facility and systems of treatment and control (and related appurtenances) that are installed or used by the permittee to achieve compliance with the conditions of this permit, as required by Department rules. This provision includes the operation of backup or auxiliary facilities or similar systems when necessary to achieve compliance with the conditions of the permit and when required by Department rules.

7. The permittee, by accepting this permit, specifically agrees to allow authorized Department personnel, upon presentation of credentials or other documents as may be required by law, access to the premises, at reasonable times, where the permitted activity is located or conducted for the purpose of:

- a. Having access to and copying any records that must be kept under the conditions of the permit;
- b. Inspecting the facility, equipment, practices, or operations regulated or required under this permit; and
- c. Sampling or monitoring any substances or parameters at any location reasonably necessary to assure compliance with this permit or Department rules.

Reasonable time may depend on the nature of the concern being investigated.

8. If, for any reason, the permittee does not comply with or will be unable to comply with any condition or limitation specified in this permit, the permittee shall immediately notify and provide the Department with the following information:

- a. a description of and cause of non-compliance; and
- b. the period of noncompliance, including exact dates and times; or, if not corrected, the anticipated time the noncompliance is expected to continue, and steps being taken to reduce, eliminate, and prevent recurrence of the noncompliance.

PERMITTEE:  
Harris Semiconductor

Permit Number: AC 05-159484  
Expiration Date: April 30, 1990

**GENERAL CONDITIONS:**

The permittee shall be responsible for any and all damages which may result and may be subject to enforcement action by the Department for penalties or revocation of this permit.

9. In accepting this permit, the permittee understands and agrees that all records, notes, monitoring data and other information relating to the construction or operation of this permitted source, which are submitted to the Department, may be used by the Department as evidence in any enforcement case arising under the Florida Statutes or Department rules, except where such use is proscribed by Sections 403.73 and 403.111, Florida Statutes.

10. The permittee agrees to comply with changes in Department rules and Florida Statutes after a reasonable time for compliance, provided however, the permittee does not waive any other rights granted by Florida Statutes or Department rules.

11. This permit is transferable only upon Department approval in accordance with Florida Administrative Code Rules 17-4.12 and 17-30.30, as applicable. The permittee shall be liable for any noncompliance of the permitted activity until the transfer is approved by the Department.

12. This permit is required to be kept at the work site of the permitted activity during the entire period of construction or operation.

13. This permit also constitutes:

- ( ) Determination of Best Available Control Technology (BACT)
- ( ) Determination of Prevention of Significant Deterioration (PSD).
- ( ) Compliance with New Source Performance Standards.

14. The permittee shall comply with the following monitoring and record keeping requirements:

- a. Upon request, the permittee shall furnish all records and plans required under department rules. The retention period for all records will be extended automatically, unless otherwise stipulated by the Department, during the course of any unresolved enforcement action.

**PERMITTEE:**  
Harris Semiconductor

**Permit Number:** AC 05-159484  
**Expiration Date:** April 30, 1990

**GENERAL CONDITIONS:**

b. The permittee shall retain at the facility or other location designated by this permit records of all monitoring information (including all calibration and maintenance records and all original strip chart recordings for continuous monitoring instrumentation), copies of all reports required by this permit, and records of all data used to complete the application for this permit. The time period of retention shall be at least three years from the date of the sample, measurement, report or application unless otherwise specified by Department rule.

c. Records of monitoring information shall include:

- the date, exact place, and time of sampling or measurements;
- the person responsible for performing the sampling or measurements;
- the date(s) analyses were performed;
- the person responsible for performing the analyses;
- the analytical techniques or methods used; and
- the results of such analyses.

15. When requested by the Department, the permittee shall within a reasonable time furnish any information required by law which is needed to determine compliance with the permit. If the permittee becomes aware that relevant facts were not submitted or were incorrect in the permit application or in any report to the Department, such facts or information shall be submitted or corrected promptly.

**SPECIFIC CONDITIONS:**

1. The maximum allowable VOC/solvent emissions from Building No. 58 shall be 3.2 tons per year.
2. The VOC/solvent vapor exhaust scrubber must be on during the working hours.
3. Annual operation shall be 8760 hours per year.
4. Objectionable odors shall not be allowed off plant property.

PERMITTEE:  
Harris Semiconductor

Permit Number: AC 05-159484  
Expiration Date: April 30, 1990

**SPECIFIC CONDITIONS:**

5. An inspection and maintenance plan shall be submitted to the DER's Central Florida District office as part of the operating permit application. The plan shall include provisions for the prevention and correction of VOC/solvent losses from leaks and equipment malfunctions.

6. By March 31 of each calendar year, an annual operating report shall be submitted to the DER's Central Florida District office demonstrating compliance with the VOC/solvent emissions limit for Building No. 58. The emissions shall be determined by a material balance scheme, verifiable on a monthly basis, and shall include the following:

- a) a beginning inventory of full containers, cylinders and storage tanks at the beginning of each calendar year;
- b) plus all purchased deliveries after the beginning inventory (verifiable by invoices);
- c) minus all quantities picked-up and shipped-off the premise after the beginning inventory (verifiable by invoices);
- d) minus all quantities deep well injected during the calendar year, justified by assumptions and established scrubber efficiencies; and,
- e) minus an ending inventory of full containers, cylinders, and storage tanks; and, should occur at the beginning of the following calendar year.

7. Each scrubber system's efficiency and potential VOC/solvent emissions shall be established by a sampling and analysis program, which includes:

- a) a sample shall be taken annually from each scrubber stack and analyzed using EPA Reference Method 25 or, with Department approval, EPA Reference Method 25A, 40 CFR 60, Appendix A;
- b) the DER's Central Florida District office shall receive 15 days notice in writing prior to sampling; and,
- c) the report, summarizing the sampling results, shall be submitted to the DER's Central Florida District office within 45 days after the last test run is completed.

8. This permit will supercede all other permits previously issued on this source/Building No. 58.

9. The source/Building No. 58 is subject to all applicable provisions of F.A.C. Chapters 17-2 and 17-4.

10. Projected potential acid emissions are 0.3 TPY.

PERMITTEE:  
Harris Semiconductor

Permit Number: AC 05-159484  
Expiration Number: April 30, 1990

**SPECIFIC CONDITIONS:**

11. Building No. 58 is subject to the provisions of F.A.C. Rules 17-2.240: Circumvention; 17-2.250: Excess Emissions; and, 17-4.130: Plant Operation - Problems.

12. Any modification pursuant to F.A.C. Rule 17-2.100(119), Modification, shall be submitted to the DER's Central Florida District office and the Bureau of Air Quality Management office for approval.

13. The permittee, for good cause, may request that this construction permit be extended. Such a request shall be submitted to the BAQM prior to 60 days before the expiration of the permit (F.A.C. Rule 17-4.090).

14. An application for an operation permit must be submitted to the Central Florida District office at least 90 days prior to the expiration date of this construction permit or within 45 days after completion of compliance testing, whichever occurs first. To properly apply for an operation permit, the applicant shall submit the appropriate application form, fee, certification that construction was completed noting any deviations from the conditions in the construction permit, and compliance test reports as required by this permit (F.A.C. Rule 17-4.220).

Issued this 31 day of March,  
1989

STATE OF FLORIDA DEPARTMENT  
OF ENVIRONMENTAL REGULATION

  
Dale Twachtmann, Secretary



State of Florida  
DEPARTMENT OF ENVIRONMENTAL REGULATION

For Routing To Other Than The Addressee	
To: _____	Location: _____
To: _____	Location: _____
To: _____	Location: _____
From: _____	Date: _____

# Interoffice Memorandum

TO: Dale Twachtmann

FROM: Steve Smallwood *SS*

DATE: March 31, 1989

SUBJ: Approval of Construction Permit Numbers:  
AC 05-157786, -157787, -158237, and -159484  
Harris Semiconductor

Attached for your approval and signature are permits prepared by Central Air Permitting for the above mentioned company to consolidate multiple permits previously issued for Buildings Numbers 51, 62, 63 and 58, which are sources involved with the fabrication and testing of integrated circuits. The project is located at Harris Semiconductor's existing facility located in the City of Palm Bay, Brevard County, Florida.

Comments were received during the public notice period.

Day 90, after which these permits will be issued by default, is: AC 05-157786 and -157787: April 8, 1989; AC 05-158237: April 19, 1989; and, AC 05-159484: May 28, 1989.

I recommend your approval and signature.

SS/BM/s

attachments

**RECEIVED**

MAR 31 1989

Office of the Secretary



Check Sheet

Company Name: Harris Semiconductor  
Permit Number: ACOS-15 7796, -157787, -158237, -159484  
PSD Number: \_\_\_\_\_  
Permit Engineer: \_\_\_\_\_

**Application:**

- Initial Application
- Incompleteness Letters
- Responses
- Waiver of Department Action
- Department Response
- Other

**Cross References:**

- 
- 
- 

**Intent:**

- Intent to Issue
- Notice of Intent to Issue
- Technical Evaluation
- BACT Determination
- Unsigned Permit

Correspondence with:

- EPA
- Park Services
- Other
- Proof of Publication
- Petitions - (Related to extensions, hearings, etc.)
- Waiver of Department Action
- Other

**Final Determination:**

- Final Determination
- Signed Permit
- BACT Determination
- Other

**Post Permit Correspondence:**

- Extensions/Amendments/Modifications
- Other



JON E. CORNELL  
President

RECEIVED

OCT 24 1991

Division of Air  
Resources Management

6 March 1991

TO WHOM IT MAY CONCERN:

I, Jon E. Cornell, President of HARRIS SEMICONDUCTOR, a sector within HARRIS CORPORATION, do hereby authorize John Steiner, Sector Director of Facilities and Environmental Affairs of said HARRIS SEMICONDUCTOR, to execute applications for Pollution Source permits to the Department of Environmental Regulation of the State of Florida, and the United States Environmental Protection Agency. Mr. Steiner is further authorized to sign monitoring reports and execute other correspondence related to these permits for the Harris Semiconductor, Melbourne, Florida site.



Jon E. Cornell



RECEIVED

DEC 17 1990

DER-BAQM

AC 05-158237  
Bldg. # 63

December 12, 1990

Mr. Garry Kuberski  
Engineer  
Florida Department of Environmental Regulation  
3319 Maguire Boulevard, Suite 232  
Orlando, Fl 32803

SUBJECT: HARRIS SEMICONDUCTOR, Source Test Report  
Scrubber Systems F04S04, F51S03, F54S02, **F63S02**.

Dear Mr. Kuberski:

Enclosed are two copies of the test report for the aforementioned scrubber systems as required by the conditions of the Amendments to Construction permits AC 05-147321, AC 05-168460 and AC 05-157786 dated June 15, 1990.

The testing also included the remaining scrubber systems of Buildings 54 and 51 to evaluate the effects of certain chemical changes and structural solvent hood changes in the fabs. These changes were implemented over the last few months as part of a continuing effort to reduce VOC/Solvent emissions at the process level.

If you have any questions, please call our office at (407) 729-5301.

Sincerely,

*Constantine Triantafyllidis*

Constantine Triantafyllidis  
Environmental Engineer  
Environmental Services Dept.

cc: C. Collins, P.E., Central Distr.  
B. Mitchell, Tallahassee  
P. Sanabani, Central Distr.  
K. Smith



AC05-158237  
BJJ # 63

RECEIVED

OCT 5 1990

DER-BAQM

October 3, 1990

Mr. Garry Kuberski  
Engineer  
Florida Department of Environmental Regulation  
3319 Maguire Boulevard, Suite 232  
Orlando, Fl 32803

SUBJECT: HARRIS SEMICONDUCTOR, BUILDINGS 4, 51, 54, 63.  
Notification of Monitoring  
Scrubber Systems FO4S04, F51S03, F54S02, **F63S02.**

Dear Mr. Kuberski:

Per our telephone conversation of 10/01/90 this letter is to notify the Central District Office that the monitoring of the above mentioned scrubber systems has been rescheduled for October 31, 1990. The monitoring period will last approximately three days.

The scrubber systems efficiency will be established utilizing EPA Method 25A or EPA Method 8 as required. The monitoring work will be performed by Air Consulting & Engineering, Inc. of Gainesville.

Should you have any questions or require any additional information please contact our office at (407) 729-5301.

Sincerely,

*Constantine Triantafyllidis*

Constantine Triantafyllidis, R.E.P.  
Environmental Services

cc: C. Collins, P.E., Central Dist.  
S. Smallwood, P.E., Tallahassee  
B. Mitchell, Tallahassee  
P. Sanabani  
K. Smith

Enclosures



September 12, 1990

Mr. Pius Sanabani  
Engineer  
Florida Department of Environmental Regulation  
3319 Maguire Boulevard, Suite 232  
Orlando, Fl 32803

SUBJECT: HARRIS SEMICONDUCTOR, BUILDINGS 4, 51, 54, 63.  
Notification of Monitoring  
Scrubber Systems FO4SO4, F51SO3, F54SO2, F63SO2.

Dear Mr. Sanabani:

In accordance with the conditions of the Amendments to Construction Permit numbers AC 05-147321, AC 05-168460 and AC 05-157786 dated June 15, 1990, the purpose of this letter is to notify the Central Florida District Office that monitoring of scrubbers F51SO3, F63SO2 and F54SO1 (previously named F63SO1) has been scheduled for a three day period beginning October 2, 1990.

As mentioned in previous correspondence, the original scrubbers F54SO1 and F54SO2 servicing Building 54 have been replaced by scrubber F63SO1 from Building 63. Scrubber F63SO1 will be renamed F54SO1. Furthermore, scrubber FO4SO4 will be monitored at this time because it was being repaired during the last round of monitoring in June, 1990.

The scrubber systems efficiency will be established utilizing EPA Method 25A or EPA Method 8 as required. The monitoring work will be performed by Air Consulting & Engineering, Inc. of Gainesville.

Should you have any questions or require any additional information please contact our office at (407) 729-5301.

Sincerely,

Constantine Triantafyllidis, R.E.P.  
Environmental Services

cc: C. Collins, P.E., Central Dist.  
S. Smallwood, P.E., Tallahassee  
B. Mitchell, Tallahassee

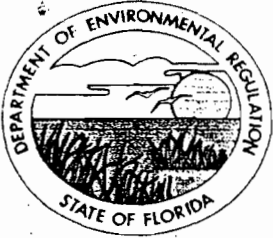

# Florida Department of Environmental Regulation

Twin Towers Office Bldg. • 2600 Blair Stone Road • Tallahassee, Florida 32399-2400

Bob Martinez, Governor

Dale Twachtman, Secretary

John Shearer, Assistant Secretary

August 29, 1990

CERTIFIED MAIL - RETURN RECEIPT REQUESTED

Mr. Kent Smith, Environmental Manager  
Harris Semiconductor  
P. O. Box 883  
Melbourne, Florida 32902-0883

Dear Mr. Smith:

Re: Amendment of Construction Permits  
AC 05-165757 Bldg. 04  
-157786 51  
-147321 54  
-164544 55  
-161706 57  
-159484 58  
-150794 59  
-168460 60  
-157787 62  
-158237 63

The Department has reviewed Constantine Triantafyllidis' letter received July 19, 1990, requesting that the above referenced air construction permits' expiration dates be extended. The Department is in agreement with the request and the following will be changed and added:

Expiration Date:

From: December 31, 1990  
To: June 30, 1991

Attachment to be Incorporated:

o Constantine Triantafyllidis' letter received July 19, 1990.

This letter must be attached to your air construction permits, as referenced above, and shall become a part of the permits.

Sincerely,

*[Signature]*  
for STEVE SMALLWOOD, P.E.  
Director  
Division of Air Resources  
Management

SS/BM/plm

Mr. Kent Smith  
August 29, 1990  
Page 2

Attachment

c: C. Collins, Central Dist.  
C. Triantafyllidis, HS



State of Florida  
DEPARTMENT OF ENVIRONMENTAL REGULATION

For Routing To Other Than The Addressee	
To: _____	Location: _____
To: _____	Location: _____
To: _____	Location: _____
From: _____	Date: _____

# Interoffice Memorandum

---

TO: Steve Smallwood  
FROM: Clair Fancy  
DATE: August 29, 1990  
SUBJ: Amendment of Construction Permits  
Harris Semiconductor

Attached for your approval and signature is a letter that will amend ten construction permits issued to the above mentioned company to extend their expiration dates. There is no controversy regarding this action.

I recommend your approval and signature.

CF/BM/plm





File #

July 17, 1990

Mr. Claire Fancy  
Bureau Chief  
Bureau of Air Regulation  
Florida Department of Environmental Regulation  
Twin Towers Office Building  
2600 Blair Stone Road  
Tallahassee, FL 32399-2400

Subject: Extension of Consolidated Construction Permits  
Harris Semiconductor, Melbourne

JUL 19 1990  
DER-BAQM

<u>Permit Nos.</u>	<u>Bldg.</u>
AC 05-165757	04
AC 05-157786	51
AC 05-147321	54
AC 05-164544	55
AC 05-161706	57
AC 05-159484	58
AC 05-150794	59
AC 05-168460	60
AC 05-157787	62
AC 05-158237	63

Dear Mr. Fancy:

This letter is submitted, on behalf of Harris Semiconductor Sector, Inc. ("Semiconductor"), to request an extension of the expiration dates of the above-referenced permits until March 31, 1991. We believe the extension is justified for the following reasons. The current specific conditions of these permits require the submission of applications for operating permits by the end of September. As you are aware, over the last several months we have been working with the Department to reduce the potential for Semiconductor's operations to contribute to odors in the areas adjacent to the facility. It is possible that some of the projects we currently have underway to accomplish this objective may not be completed by the end of September. The stack extensions associated with the Building 54 operations should be completed by the end of September. However, another major element of our odor reduction efforts which consists of a facility-wide substitution of certain phenolic process chemicals with non-phenolic ones, where reasonably possible, may not be completed by October 1st. We believe this program is important because these non-phenolic compounds should prove to be much less odoriferous in nature.

Mr. Claire Fancy  
July 17, 1990  
Page 2.

This program is considerably more complex and difficult to implement than the stack extensions. Due to the sophisticated and sensitive nature of the integrated circuits manufactured at the facility, in many instances, a substitution of process chemicals requires customer (which in many instances is the U.S. Government) approval.

The whole project, including necessary customer approval and the actual chemical substitutions, may take several months or more. We believe, from the Department's and Semiconductor's perspective, it would be better to complete this process prior to submission of the applications for operating permits. It should be noted that some chemical changes may not be possible if the U.S. Government objects to the substitution. Should the Department have any questions or require any additional information, please contact our office at 407/729-5301.

Yours sincerely,

*Constantine Triantafyllidis*

Constantine Triantafyllidis  
Environmental Engineer  
Environmental Services

cc: T. Sawicki /  
B. Mitcell / 7/24/90  
C. Collins /

E/929/90

P 256 396 101

**RECEIPT FOR CERTIFIED MAIL**

NO INSURANCE COVERAGE PROVIDED  
NOT FOR INTERNATIONAL MAIL

(See Reverse)

\* U.S.G.P.O. 1989-234-555

PS Form 3800, June 1985

Sent to Mr. Alvin N. Critzer	
Plant Mgr.	
Harris Semiconductor	
P.O. Station 883	
Melbourne, FL 32901	
Postage	\$
Certified Fee	
Special Delivery Fee	
Restricted Delivery Fee	
Return Receipt showing to whom and Date Delivered	
Return Receipt showing to whom, Date, and Address of Delivery	
TOTAL Postage and Fees	\$
Postmark or Date mailed: 6/19/90 AC 05-157786	

● **SENDER:** Complete items 1 and 2 when additional services are desired, and complete items 3 and 4.

Put your address in the "RETURN TO" Space on the reverse side. Failure to do this will prevent this card from being returned to you. The return receipt fee will provide you the name of the person delivered to and the date of delivery. For additional fees the following services are available. Consult postmaster for fees and check box(es) for additional service(s) requested.

1.  Show to whom delivered, date, and addressee's address.      2.  Restricted Delivery (Extra charge)

3. Article Addressed to: Mr. Alvin N. Critzer Plant Manager Harris Semiconductor P.O. Box 883 Melbourne, FL 32901		4. Article Number P 256 396 101	
		Type of Service: <input type="checkbox"/> Registered <input type="checkbox"/> Insured <input checked="" type="checkbox"/> Certified <input type="checkbox"/> COD <input type="checkbox"/> Express Mail <input type="checkbox"/> Return Receipt for Merchandise	
		Always obtain signature of addressee or agent and DATE DELIVERED.	
5. Signature — Addressee <b>X</b>		8. Addressee's Address (ONLY if requested and fee paid)	
6. Signature — Agent <b>X</b> <i>William J. [Signature]</i>			
7. Date of Delivery			

File Copy



# Florida Department of Environmental Regulation

Twin Towers Office Bldg. • 2600 Blair Stone Road • Tallahassee, Florida 32399-2400

Bob Martinez, Governor

Dale Twachmann, Secretary

John Shearer, Assistant Secretary

June 18, 1990

CERTIFIED MAIL - RETURN RECEIPT REQUESTED

Mr. Alvin N. Critzer, Plant Manager  
Harris Semiconductor  
P. O. Box 883  
Melbourne, Florida 32901

Dear Mr. Critzer:

Re: Amendment to Construction Permit: AC 05-157786  
Harris Semiconductor: Building 51

The Department has reviewed your cover letter with enclosures received May 14, 1990, which requested a reduction in the allowable VOC/solvent emission limit contained in the above referenced construction permit. The Department agrees with the request and the following will be changed:

Specific Condition No. 1

FROM:

The maximum allowable VOC/solvent emissions from Building No. 51 shall be 33.3 tons per year.

TO:

The maximum allowable VOC/solvent emissions from Building No. 51 shall be 27.3 tons per year.

Attachment to be Incorporated

- Mr. Alvin N. Critzer's letter with enclosures received May 14, 1990.

Mr. Alvin N. Critzer  
Page 2  
June 18, 1990

This letter must be attached to the construction permit, No. AC 05-157786, and shall become a part of the permit.

Sincerely,



*for* STEVE SMALLWOOD, P.E.  
Director  
Division of Air Resources  
Management

SS/BM/plm

Attachment

c: C. Collins, Central Dist.  
K. Smith, HS

Ready File }  
Bruce Mitchell } 6-18-90 RAL

Attachment Available Upon Request

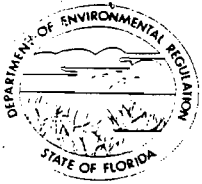

State of Florida  
DEPARTMENT OF ENVIRONMENTAL REGULATION

For Routing To Other Than The Addressee	
To: _____	Location: _____
To: _____	Location: _____
To: _____	Location: _____
From: _____	Date: _____

# Interoffice Memorandum

TO: Steve Smallwood  
FROM: Clair Fancy  
DATE: June 18, 1990  
SUBJ: Amendment to Construction Permit: AC 05-157786  
Harris Semiconductor: Building 51

*Is signed for  
Steve. He is on  
vacation this  
week.*

Attached for your approval and signature is a letter prepared by the Bureau of Air Regulation that will amend the above referenced construction permit. The amendment will reduce the allowable VOC/solvent emission limit contained in the above referenced permit. The existing facility is located in the City of Palm Bay, Brevard County, Florida.

The amendment is not controversial. I recommend your approval and signature.

CF/BM/plm

Attachment

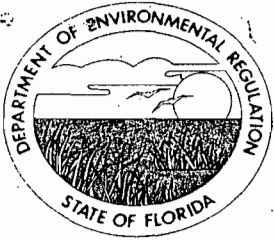

# Florida Department of Environmental Regulation

Twin Towers Office Bldg. • 2600 Blair Stone Road • Tallahassee, Florida 32399-2400

Bob Martinez, Governor

Dale Twachtmann, Secretary

John Shearer, Assistant Secretary

June 15, 1990

CERTIFIED MAIL - RETURN RECEIPT REQUESTED

Mr. Kent Smith  
Environmental Manager  
Harris Semiconductor  
P. O. Box 883  
Melbourne, Florida 32902-0883

Dear Mr. Smith:

Re: Amendment to Construction Permit: AC 05-168460  
Harris Semiconductor: Building 63

The Department has reviewed Ms. Nancy Baldisserotto's letters received on April 10 and May 15, 1990. The purpose of the letters was to notify the Department of the phasing-out of a wafer fabrication area and an associated scrubber system (F63S01) and exhaust the remaining equipment it serviced to another existing scrubber system (F63S02). The Department acknowledges the notification with the following conditions:

- The scrubber system's (F63S02) efficiency shall be established for VOC/Solvents using EPA Method 25A pursuant to F.A.C. Rule 17-2.700 and 40 CFR 60, Appendix A. Other test methods may be used with prior written Departmental approval pursuant to F.A.C. Rule 17-2.700(3).
- The maximum potential VOC/Solvent emissions shall be calculated using the results (actual emissions) from the efficiency test and prorated to 8760 hrs/yr. This value shall then be compared to the current allowable emission limit for the building/source to determine if any permitting action is necessary.
- The Department's Central District office shall be notified in writing 15 days prior to conducting tests.
- The results of the tests shall be submitted to the Department's Central District office within 45 days after the last test run is completed.

Attachments to be Incorporated:

- Ms. Nancy Baldisserotto's letter received April 10, 1990.
- Ms. Nancy Baldisserotto's letter received May 15, 1990.



Mr. Kent Smith  
Page 2  
June 15, 1990

This letter must be attached to your air construction permit, AC 05-168460, and shall become a part of the permit.

Sincerely,



STEVE SMALLWOOD, P.E.  
Director  
Division of Air Resources  
Management

SS/BM/plm

Attachments

c: C. Collins, Central Dist.  
N. Baldisserotto, HS

ATTACHMENTS AVAILABLE UPON REQUEST



State of Florida  
DEPARTMENT OF ENVIRONMENTAL REGULATION

For Routing To Other Than The Addressee	
To: _____	Location: _____
To: _____	Location: _____
To: _____	Location: _____
From: _____	Date: _____

# Interoffice Memorandum

TO: Steve Smallwood

FROM: Clair Fancy

DATE: June 15, 1990

SUBJ: Amendment to Construction Permit: AC 05-168460  
Harris Semiconductor: Building 63

158237

Attached for your approval and signature is a letter prepared by the Bureau of Air Regulation that will amend the above referenced construction permit. The amendment will allow the company to deactivate an existing scrubber system (F63S01) and exhaust the remaining equipment it serviced to an existing scrubber (F63S02). The existing facility is located in the City of Palm Bay, Brevard County, Florida.

The amendment is not controversial. I recommend your approval and signature.

CF/BM/plm

Attachments



# Florida Department of Environmental Regulation

Twin Towers Office Bldg. • 2600 Blair Stone Road • Tallahassee, Florida 32399-2400

Bob Martinez, Governor

Dale Twachtmann, Secretary

John Shearer, Assistant Secretary

June 15, 1990

CERTIFIED MAIL - RETURN RECEIPT REQUESTED

Mr. Kent Smith  
Environmental Manager  
Harris Semiconductor  
P. O. Box 883  
Melbourne, Florida 32902-0883

Dear Mr. Smith:

Re: Amendment to Construction Permit: AC 05-157786  
Harris Semiconductor: Building 51

The Department has reviewed Ms. Nancy Baldisserotto's letter received on May 24, 1990. The purpose of the letter was to notify the Department of your intent to deactivate an existing scrubber system (F51S01) and exhaust the remaining equipment it serviced to another existing wet scrubber system (F51S03). The Department acknowledges the notification with the following conditions:

- The scrubber system's (F51S03) efficiency shall be established for VOC/Solvents using EPA Method 25A pursuant to F.A.C. Rule 17-2.700 and 40 CFR 60, Appendix A. Other test methods may be used with prior written Departmental approval pursuant to F.A.C. Rule 17-2.700(3).
- The maximum potential VOC/Solvent emissions shall be calculated using the results (actual emissions) from the efficiency test and prorated to 8760 hrs/yr. This value shall then be compared to the current allowable emission limit for the building/source to determine if any permitting action is necessary.
- The Department's Central District office shall be notified in writing 15 days prior to conducting tests.
- The results of the tests shall be submitted to the Department's Central District office within 45 days after the last test run is completed.

Attachment to be Incorporated:

- Ms. Nancy Baldisserotto's letter received May 24, 1990.

Mr. Kent Smith  
Page 2  
June 15, 1990

This letter must be attached to your air construction permit, AC 05-157786, and shall become a part of the permit.

Sincerely,



*for* STEVE SMALLWOOD, P.E.  
Director  
Division of Air Resources  
Management

SS/BM/plm

Attachment

c: C. Collins, Central Dist.  
N. Baldisserotto, HS

ATTACHMENTS AVAILABLE UPON REQUEST



State of Florida  
DEPARTMENT OF ENVIRONMENTAL REGULATION

For Routing To Other Than The Addressee	
To: _____	Location: _____
To: _____	Location: _____
To: _____	Location: _____
From: _____	Date: _____

# Interoffice Memorandum

TO: Steve Smallwood  
FROM: Clair Fancy  
DATE: June 15, 1990  
SUBJ: Amendment to Construction Permit: AC 05-157786  
Harris Semiconductor: Building 51

Attached for your approval and signature is a letter prepared by the Bureau of Air Regulation that will amend the above referenced construction permit. The amendment will allow the company to deactivate an existing scrubber system (F51S01) and exhaust the remaining equipment it serviced to an existing wet scrubber system (F51S03). The existing facility is located in the City of Palm Bay, Brevard County, Florida.

The amendment is not controversial. I recommend your approval and signature.

CF/BM/plm

Attachment



RECEIVED

May 22, 1990

MAY 24 1990

Mr. Claire Fancy  
Bureau Chief  
Bureau of Air Regulation  
Florida Department of Environmental Regulation  
Twin Towers Office Building  
2600 Blair Stone Road  
Tallahassee, FL 32399-2400

DER-BAQM

Re: Exhaust system modification; Permit no. AC 05-157786  
Building 51 Consolidated Air Permit

Dear Mr. Fancy:

By this letter, Harris Semiconductor is providing the Department with notice of the consolidation of manufacturing activity in the building 51 wafer fab, and the resulting deactivation of one of the scrubber systems servicing the area. During the late months of 1989, various pieces of manufacturing equipment were either deactivated and removed from the east module, or relocated to the west module. The changes have resulted in reduced exhaust demand on the scrubbers servicing the area. Attachment I is a list of the remaining equipment and associated exhaust demand on the scrubbers.

Scrubber no. F51S03 is a Duall Industry model F-101 four-stage horizontal cross-flow scrubber rated for 24,000 cfm of exhaust. The system has adequate capacity to handle the equipment currently exhausted to scrubber F51S01, which now requires only 1750 cfm of exhaust. (See attachment II for additional scrubber information.)

If the Department has no objection, we will be deactivating scrubber no. F51S01 sometime next month, and exhaust the remaining equipment to scrubber no. F51S03. If you have any questions, please give me a call at (407) 729-4061.

Sincerely,

Nancy Baldisserotto  
Senior Environmental Engineer

cc: B. Mitchell, Tallahassee  
C. Collins, Orlando



**ATTACHMENT I.**

Analog East Exhaust  
aneastex

Env. I.D.	Description	CFM
-----		
F51S01		
666	6' Acid Station	750
667	Ion Implant	600
668	Furnace bank L	200
669	Furnace bank M	200
670	Gas cabinet	0
671	Gas cabinet	0
	Total:	1750 CFM

-----		
F51S02		
653	6' Solvent hood	1650
650	Box wash	300
762	6' Solvent clean	750
616	Cup clean	1500
607	NICR lift off	1000
	Vac Pump	25
	Vac Pump	25
	Vac Pump near SEM	25
	Laser Scribe	25
	Total =	5300 CFM

-----		
F51S03		
643	6' Acid station	1650
644	6' Acid station	750
645	6' Acid station	750
646	6' Acid station	750
647	8' Resist acid station	1000
622	Tube Clean	1500
761	Acid	1000
602	Drytech	160
604	Acid	1100
654	Furnace Bank A	375
655	Furnace Bank B	375
656	Furnace Bank C	375
657	Furnace Bank D	375
658	Furnace Bank E	375
659	Furnace Bank F	375
660	Furnace Bank G	375
661	Furnace Bank H	375
662	LPCVD J	375
	LPCVD K	375
	2" LN2 vent	0
675	Gas Cabinet	125
674	Gas Cabinet	125
673	Gas Cabinet	125
672	Gas Cabinet	125
	J bank Vacuum Pump	5
	Total =	12915 CFM

**ATTACHMENT II.**

## SCRUBBER INFORMATION

---

HARRIS ID # : F51S01  
MANUFACTURER : TRI-MER CORP.           MODEL NUMBER : F/W 3  
SERIAL NUMBER: 7026                    MATERIAL : PVC  
DESCRIPTION : HORIZONTAL COUNTER-FLOW, MIST ELIMINATOR,  
POLYPRO FILTER PACK; DRAWING D1000-585 (6/80)

### DESIGN DATA

VOLUME FLOW RATE (CFM): 9,500   PRESSURE DROP (IN):  
RECIRCULATION RATE (GPM): 30    MAKE UP RATE (GPM): 3.0

### ACTUAL DATA

VOLUME FLOW RATE (CFM):            PRESSURE DROP (IN): N/E DATE: 6/3/87  
RECIRCULATION RATE (GPM): N/E      MAKE UP RATE (GPM): N/R DATE:   "

## RECIRCULATION PUMP INFORMATION

---

MANUFACTURER : FLOTEK                MODEL NUMBER : C7P3-1194U  
SERIAL NUMBER: 603887B801            HP : 1   RPM : 3450/2850  
BRKR LOCATION: NEXT TO UNIT         FED FROM MCC : TAC 76127

## FAN INFORMATION

---

HARRIS ID # : F51E13  
MANUFACTURER : TRI-MER CORP.        MODEL NUMBER: 24 UB  
SERIAL NUMBER: 7026                  MATERIAL : PVC  
DESCRIPTION : CENTRIFUGAL BLOWER, BACKWARD INCLINED BLADES

### DESIGN DATA

VOLUME FLOW RATE (CFM): 6,000    STATIC PRESS (IN):

### ACTUAL DATA

VOLUME FLOW RATE (CFM):            SPEED (RPM):            DATE:  
STATIC PRESS (IN):                 DATE:

## FAN MOTOR INFORMATION

---

MANUFACTURER : LINCOLN               MODEL NUMBER :  
SERIAL NUMBER:                        HP : 15   RPM : 1750  
BRKR LOCATION: NEXT TO UNIT         FED FROM MCC : TAC 76127

SCRUBBER INFORMATION

HARRIS ID # : F51S02  
MANUFACTURER : DUAL IND. MODEL NUMBER : F-101  
SERIAL NUMBER: 4476 MATERIAL : PVC  
DESCRIPTION : HORIZONTAL CROSS-FLOW, FOUR STAGE, MIST ELIMINATOR,  
SINGLE FILTER PACK, OPEN ORIFICE TYPE SPRAY NOZZLES

DESIGN DATA

VOLUME FLOW RATE (CFM): 10,000 PRESSURE DROP (IN): 2.0  
RECIRCULATION RATE (GPM): 30 MAKE UP RATE (GPM): 1.5

ACTUAL DATA

VOLUME FLOW RATE (CFM): 8,200 PRESSURE DROP (IN): N/E DATE: 1/16/87  
RECIRCULATION RATE (GPM): 12 MAKE UP RATE (GPM): N/E DATE: 6/3/87

RECIRCULATION PUMP INFORMATION

MANUFACTURER : GENERAL ELECT. MODEL NUMBER : 5K47SG976  
SERIAL NUMBER: N/A HP : 2 RPM : 3450  
BRKR LOCATION: FED FROM MCC :

FAN INFORMATION

HARRIS ID # : F51E18  
MANUFACTURER : DUAL IND. MODEL NUMBER: 49  
SERIAL NUMBER: 4476 MATERIAL : PVC  
DESCRIPTION : CENTRIFUGAL BLOWER

DESIGN DATA

VOLUME FLOW RATE (CFM): 10,000 STATIC PRESS (IN):

ACTUAL DATA

VOLUME FLOW RATE (CFM): 8,200 SPEED (RPM): DATE:  
STATIC PRESS (IN): 4.3 DATE: 1/16/87

FAN MOTOR INFORMATION

MANUFACTURER : MODEL NUMBER :  
SERIAL NUMBER: HP : 15 RPM : 1750  
BRKR LOCATION: FED FROM MCC :

ttachment :

## SCRUBBER INFORMATION

---

HARRIS ID # : F51S03  
MANUFACTURER : DUALL IND.                      MODEL NUMBER : F-101  
SERIAL NUMBER: 4194                              MATERIAL : PVC  
DESCRIPTION : HORIZONTAL CROSS-FLOW, FOUR STAGE, MIST ELIMINATOR,  
SINGLE FILTER PACK, OPEN ORIFICE TYPE SPRAY NOZZLES

### DESIGN DATA

VOLUME FLOW RATE (CFM): 24,000      PRESSURE DROP (IN): 2.0  
RECIRCULATION RATE (GPM): 72              MAKE UP RATE (GPM): 4.0

### ACTUAL DATA

VOLUME FLOW RATE (CFM):                      PRESSURE DROP (IN): N/E DATE: 6/3/87  
RECIRCULATION RATE (GPM): N/E                      MAKE UP RATE (GPM): N/E DATE: "

## RECIRCULATION PUMP INFORMATION

---

MANUFACTURER : LINCOLN                      MODEL NUMBER : 2509  
SERIAL NUMBER: 1605666 3420                      HP : 1.5 RPM : 3420  
BRKR LOCATION:                              FED FROM MCC : #5

## FAN INFORMATION

---

HARRIS ID # : F51E03  
MANUFACTURER : TRI-MER CORP.                      MODEL NUMBER: 44 CW  
SERIAL NUMBER: 5303                              MATERIAL : PVC  
DESCRIPTION : CENTRIFUGAL BLOWER, BACKWARD INCLINED BLADES

### DESIGN DATA

VOLUME FLOW RATE (CFM): 30,000      STATIC PRESS (IN):

### ACTUAL DATA

VOLUME FLOW RATE (CFM):                      SPEED (RPM):              DATE:  
STATIC PRESS (IN):                      DATE:

## FAN MOTOR INFORMATION

---

MANUFACTURER :                              MODEL NUMBER :  
SERIAL NUMBER:                              HP : 30 RPM : 1750  
BRKR LOCATION:                              FED FROM MCC : #5

# The Tri-Mer Fume Washer

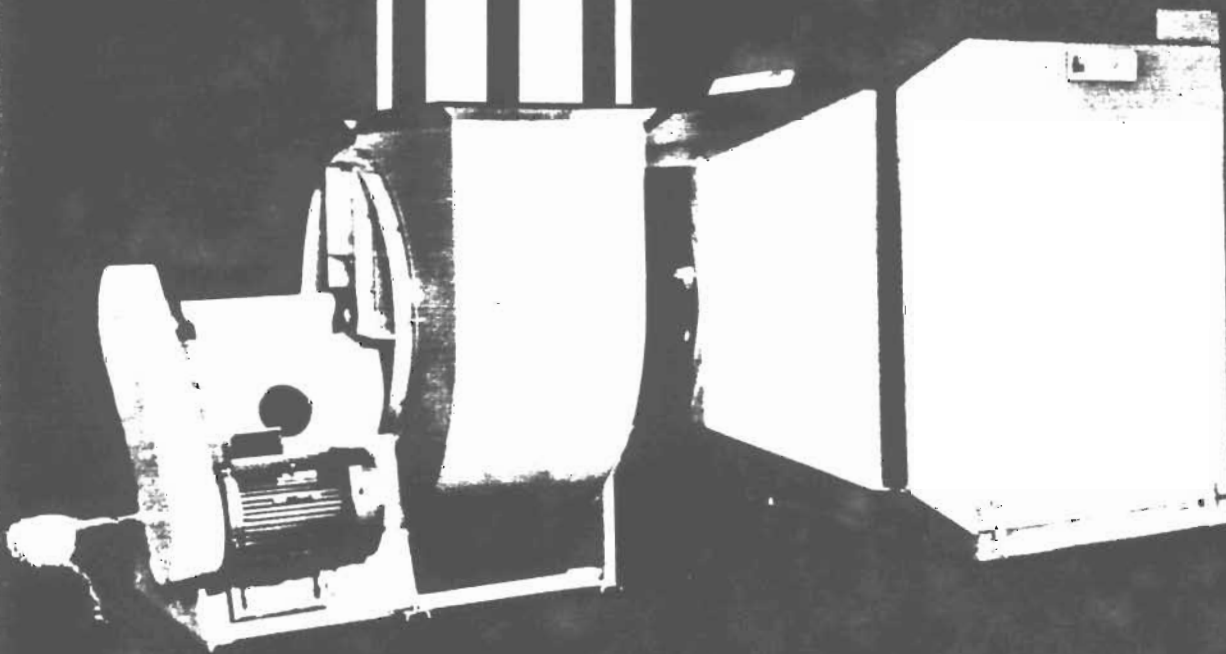
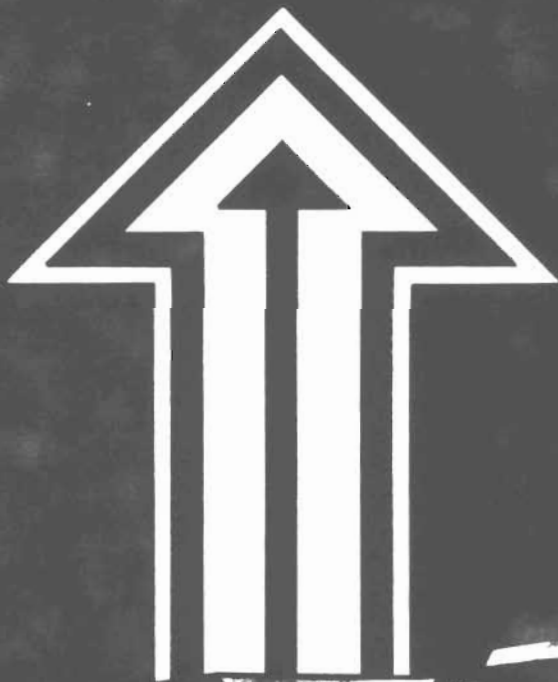

**Designers and Manufacturers of Corrosion Control Systems**

# Design Features of the Tri-Mer Fume Washer

TRI-MER fume washers offer an efficient economically packaged solution to your corrosive fume problems. Couple this unit to a TRI-MER all PVC fan, or use your existing fan, and you're ready for operation. A simple inexpensive installation.

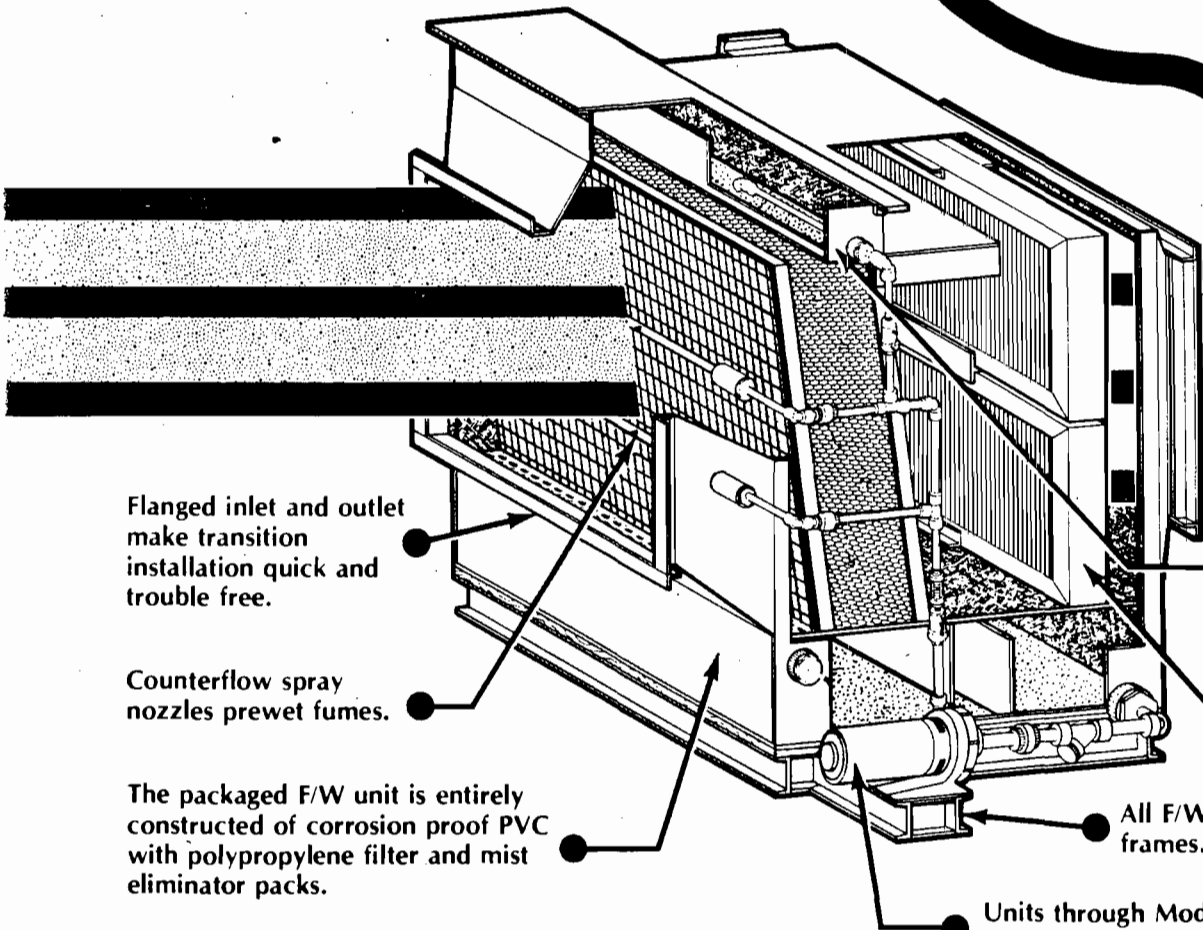

Flanged inlet and outlet make transition installation quick and trouble free.

Counterflow spray nozzles prewet fumes.

The packaged F/W unit is entirely constructed of corrosion proof PVC with polypropylene filter and mist eliminator packs.

An overflow weir keeps the polypropylene filter pack flooded with water.

Downstream mist eliminator packs pull excess moisture from the air stream.

All F/W units come with self supporting frames.

Units through Model F/W-9 are available with integral recirculation tank and pump as shown.  
NOTE — Models F/W-10 through F/W-16 require remote recirculation tanks per manufacturers suggestion.



F/W	A	B	C	D	E	F	G	H	J	K	L	M	R	CHANNEL	ANGLE	DRAIN	G. P. M.	No. OF HEADERS	PIPE	CFM CAPACITY			
1	3'-11 1/2"	4'-4 1/2"	3'-6"	4'-3"	5'-3"	3'-4"	3'-4"	4'-10"	6"	6"	28"	28"	1'-8"	2'-0 1/4"	3'-0 1/4"	8"	4" @ 5.4 #	1 1/2" x 1 1/2" x 3/16"	3"	8	2	3/4"	3,000 to 5,500
2	4'-3 1/2"	4'-8 1/2"	3'-10"	4'-6 1/4"	5'-6 1/4"	3'-8"	3'-4"	5'-2"	4 1/2"	4 1/2"	35"	35"	1'-10"	2'-2 1/4"	3'-2 1/4"	8"	4" @ 5.4 #	1 1/2" x 1 1/2" x 3/16"	3"	9	2	3/4"	5,500 to 7,000
3	5'-0 1/2"	5'-5 1/2"	3'-6"	5'-3 1/4"	6'-3 3/4"	4'-5"	4'-5"	4'-10"	8"	8"	37"	37"	2'-4 1/2"	2'-7 1/4"	3'-7 1/4"	8"	4" @ 5.4 #	1 1/2" x 1 1/2" x 3/16"	3"	12	2	3/4"	7,000 to 9,500
4	5'-6"	5'-11"	4'-0"	5'-8 1/4"	6'-8 1/4"	4'-10"	4'-10"	5'-6"	6 1/2"	6 1/2"	45"	45"	2'-5"	2'-9 1/4"	3'-9 1/4"	9"	4" @ 5.4 #	2" x 2" x 1/4"	3"	14	2	3/4"	9,500 to 11,500
5	6'-0"	6'-5"	3'-8 1/2"	6'-2 1/4"	7'-2 1/4"	5'-4"	5'-4"	5'-2 1/2"	9 1/2"	9 1/2"	45"	45"	2'-8"	3'-0 1/4"	4'-0 1/4"	9"	4" @ 5.4 #	2" x 2" x 1/4"	3"	16	2	3/4"	11,500 to 14,000
6	6'-8"	7'-1"	4'-1 1/2"	6'-10 1/4"	7'-10 1/4"	6'-0"	6'-0"	6'-1 1/2"	11"	11"	50"	50"	3'-0"	3'-4 1/4"	4'-4 1/4"	1'-0"	4" @ 5.4 #	2" x 2" x 1/4"	3"	19	2	3/4"	14,000 to 17,000
7	6'-11"	7'-5"	3'-10 1/4"	7'-3"	8'-3"	6'-4"	6'-4"	5'-10 1/4"	11"	11"	54"	54"	3'-2"	3'-6 1/4"	4'-6 1/4"	1'-0"	4" @ 5.4 #	2" x 2" x 1/4"	3"	22	2	3/4"	17,000 to 20,000
8	7'-8"	8'-1"	4'-3"	7'-10 1/4"	8'-10 1/4"	7'-0"	7'-0"	6'-3"	1'-0 1/2"	1'-0 1/2"	59"	59"	3'-6"	3'-9 1/4"	3'-9 1/4"	1'-0"	4" @ 5.4 #	2" x 2" x 1/4"	3"	28	2	3/4"	20,000 to 24,000
9	8'-5"	9'-0"	4'-0 1/4"	8'-6"	9'-8"	7'-9"	7'-9"	6'-0 1/4"	1'-1 1/2"	1'-1 1/2"	66"	66"	3'-10 1/2"	4'-2 1/4"	5'-2 1/4"	1'-0"	4" @ 5.4 #	2" x 2" x 1/4"	3"	34	3	3/4"	24,000 to 30,000
10	9'-7"	4'-5"	9'-11 1/4"	8'-11"	8'-11"	6'-5"	1'-3 1/2"	1'-3 1/2"	76"	76"	4'-5 1/2"	5'-0 1/4"	1'-0"	6" @ 8.2 #	2" x 2" x 1/4"	3"	44	3	1"	30,000 to 40,000			
11	12'-1"	4'-2 1/2"	9'-9 1/4"	8'-9"	11'-5"	6'-2 1/2"	10"	2'-2"	85"	85"	5'-8"	4'-11 1/4"	1'-0"	6" @ 8.2 #	2" x 2" x 1/4"	3"	56	3	1"	40,000 to 50,000			
12	14'-5"	4'-5 1/2"	9'-9 1/4"	8'-9"	13'-9"	8'-5 1/2"	10"	2'-7 1/2"	85"	102"	6'-10 1/2"	4'-11 1/4"	2'-0"	6" @ 8.2 #	2" x 2" x 1/4"	3"	66	3	1"	50,000 to 60,000			
14	17'-9"	4'-5 1/2"	9'-9 1/4"	8'-9"	17'-1"	8'-5 1/2"	10"	3'-2 1/2"	85"	128"	8'-5 1/2"	4'-11 1/4"	2'-0"	6" @ 8.2 #	2" x 2" x 1/4"	3"	81	3	1"	60,000 to 75,000			
15	20'-8"	4'-2 1/2"	9'-9 1/4"	8'-9"	19'-10"	8'-2 1/2"	10"	3'-9 1/2"	85"	147"	9'-11"	4'-11 1/4"	2'-0"	6" @ 8.2 #	2" x 2" x 1/4"	3"	93	3	1 1/2"	75,000 to 87,000			
16	20'-8"	4'-7"	11'-0 1/4"	10'-0"	20'-0"	8'-7"	1'-5 1/2"	3'-0"	85"	240"	10'-0"	5'-6 1/4"	2'-0"	6" @ 8.2 #	2" x 2" x 1/4"	3"	106	3	1 1/2"	87,000 to 100,000			

\* NOTE — For exact unit weight check with manufacturers.

\* NOTE — Double pack models are available where particularly heavy loadings exist. Check with manufacturer for dimensional changes.

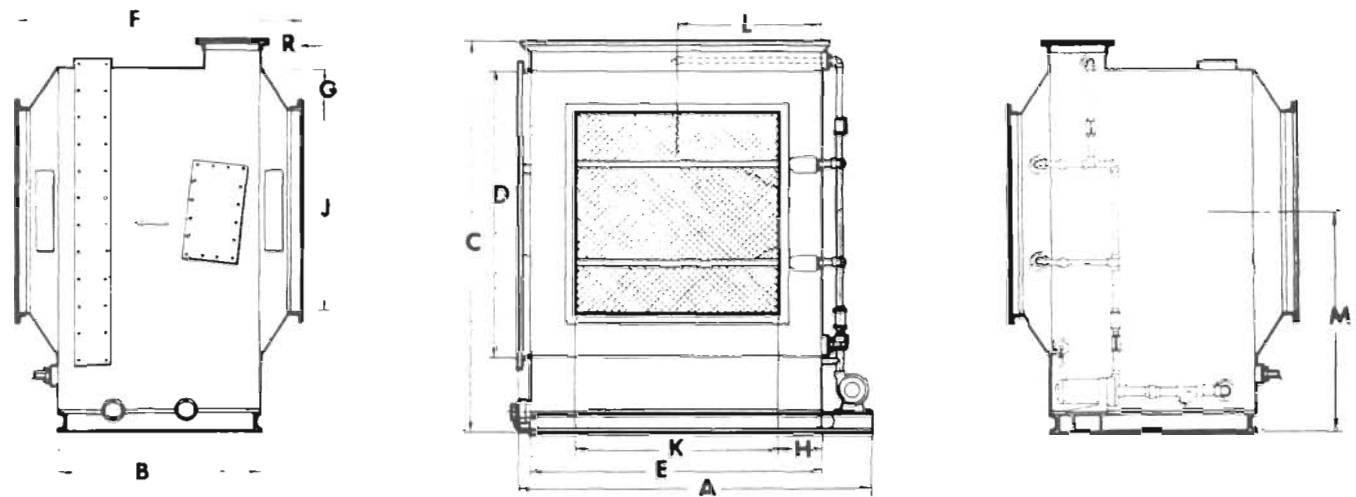

Typical three view drawing of units with integral recirculation tanks.

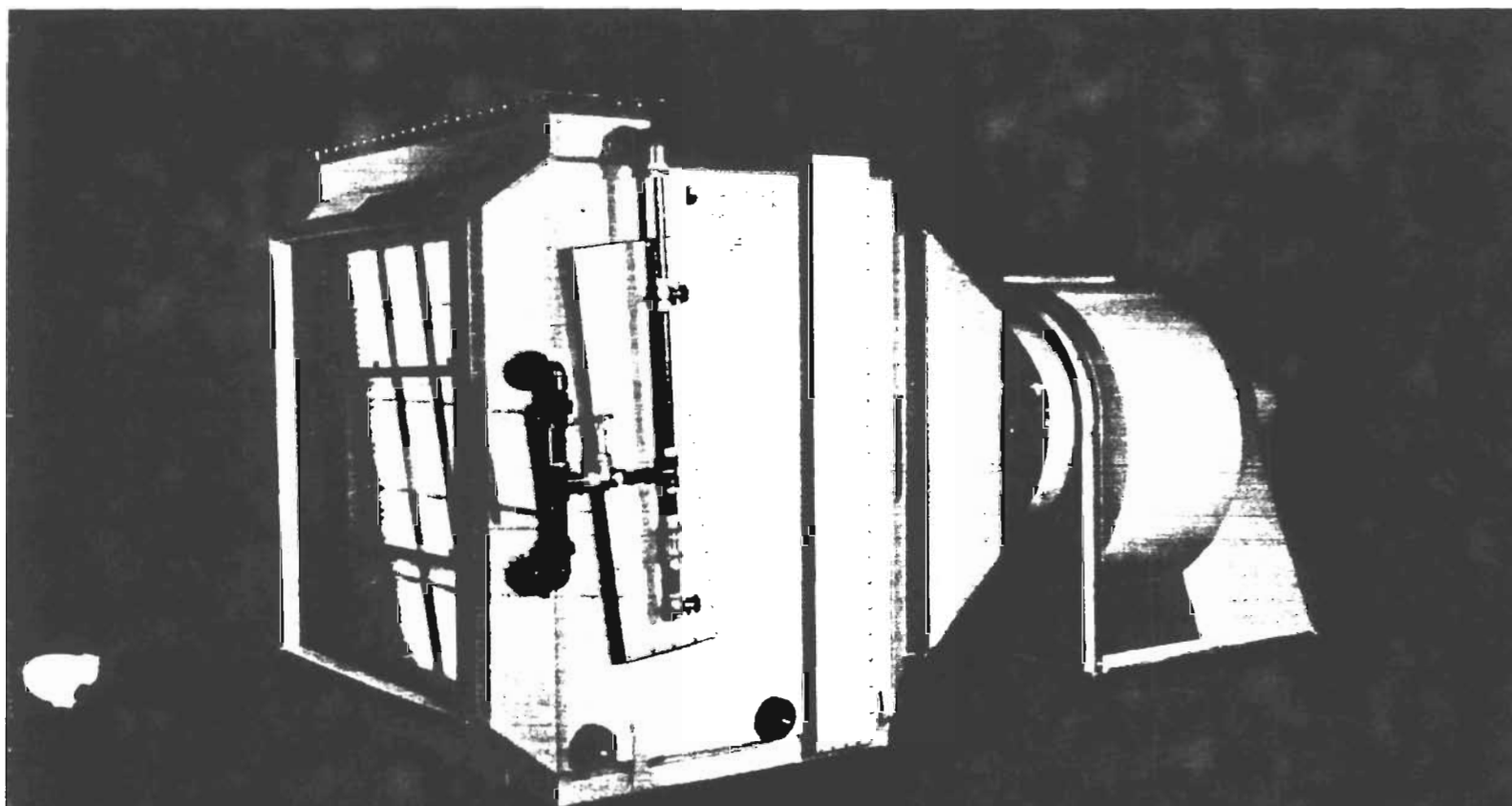

An assembled F/W-10 complete with Tri-Mer PVC Fan & Transition

# Other TRI-MER PVC Equipment

As long time specialists in designing corrosive fume control systems, TRI-MER offers a complete line of PVC air movers and associated equipment. This includes the patented fan/separator (fume scrubber), fume washers (crossflow scrubbers), PVC centrifugal fans, an *all PVC* stack fan, as well as PVC hoods and duct. Special fabrications such as consoles, tanks, and small plating lines are available.

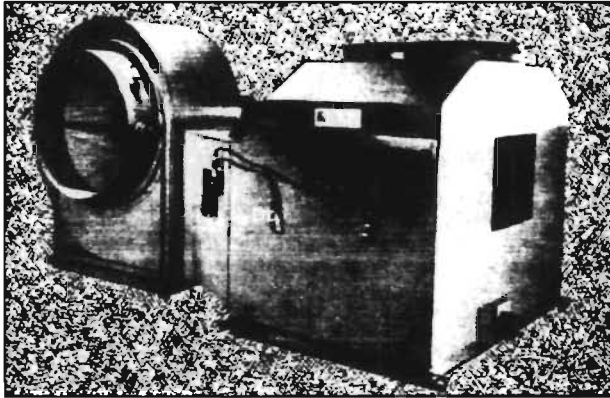

Fan/Separator

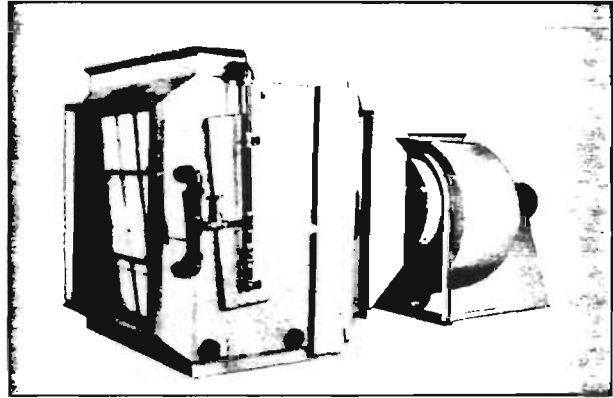

Fume/Washer (Crossflow Scrubber)

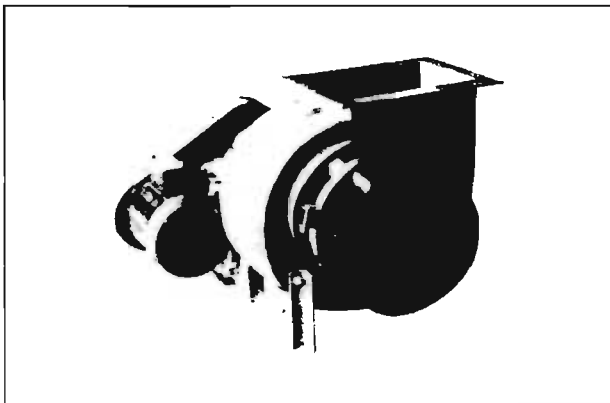

PVC Centrifugal Fan

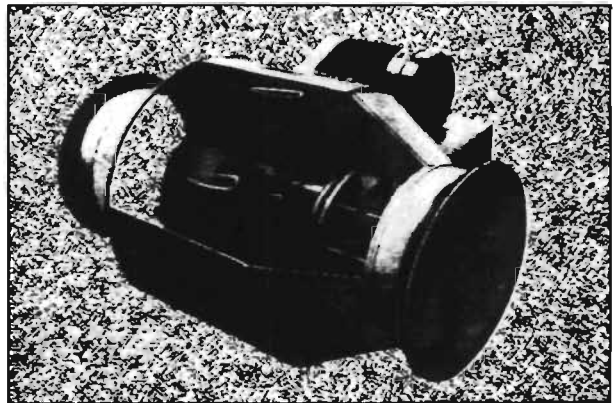

PVC Stack Fan (Cutaway View)

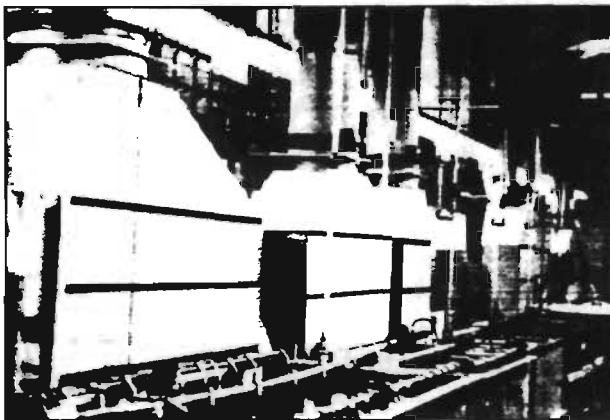

PVC Hoods & Duct

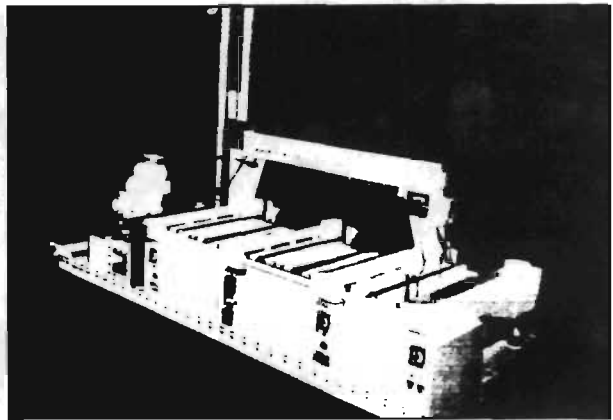

Special Fabrications



## Tri-Mer Corporation

Factory and Main Offices  
1400 Monroe, Owosso, Michigan 48867  
Phone (517) 723-7838 Telex 228545



## Tri-Mer Corporation

California Sales Offices  
P.O. Box 1152, Costa Mesa, California 92626  
Phone: (714) 548-5853

**K** EUROPEAN REPRESENTATIVE  
**JAEGER K. G.**  
D BRAUNSCHWEIG, WEST GERMANY

Litho in U.S.A.

BEST AVAILABLE COPY

# PVC

UNPLASTICIZED POLYVINYL CHLORIDE

## NON-OVERLOADING BLOWERS

(BACKWARD INCLINED BLADES)

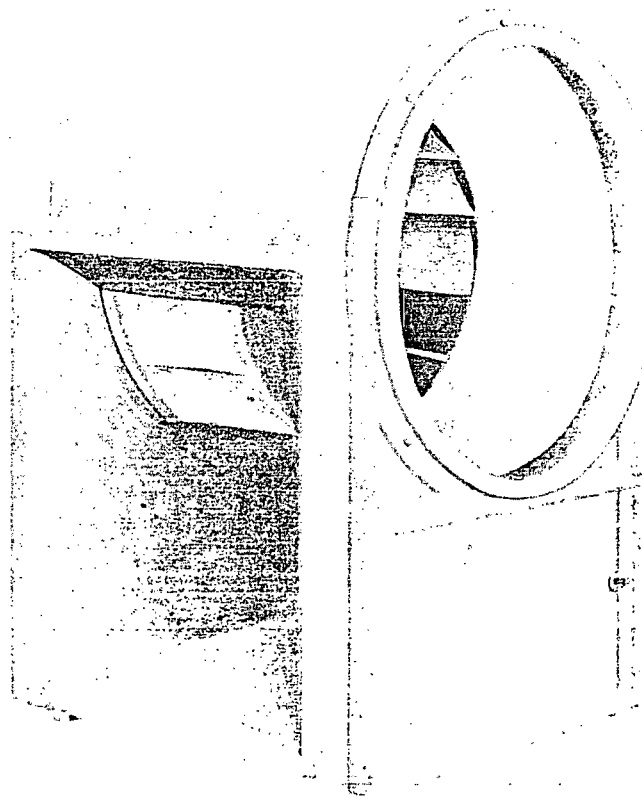

**Tri-Mer<sup>®</sup> Corporation**

**Air Pollution Control Systems**

*DESIGN • ENGINEERING • MANUFACTURING*

1400 Monroe Street • Owosso, Michigan 48867 • 517-723/5124 • Telex 228545

# STANDARD NOMENCLATURE

## Direction of Rotation and Discharge

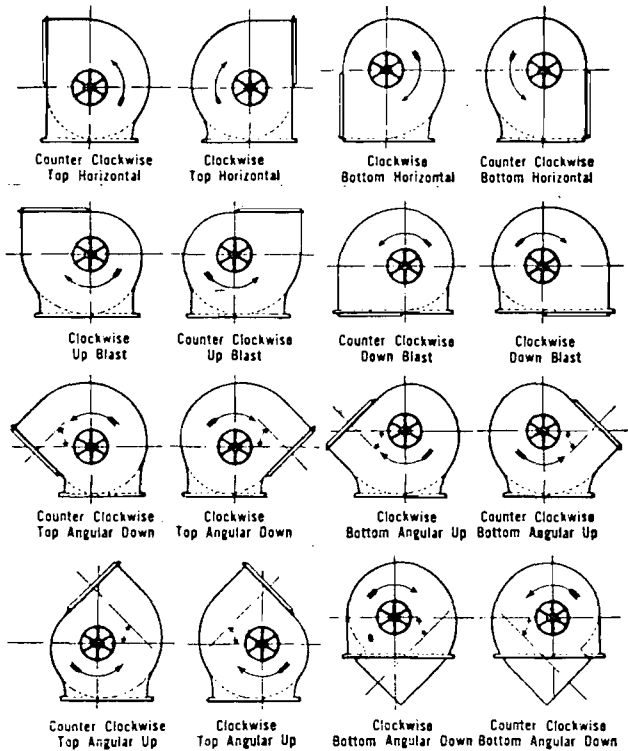

Direction of rotation is determined from the drive side. On single inlet fans, drive side is considered as opposite inlet, regardless of actual drive location.

## ARRANGEMENTS OF DRIVE

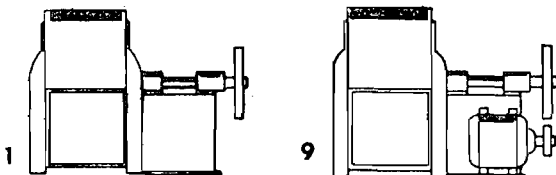

### ARRANGEMENT No. 1, SWSI

For belt drive or direct connection. Wheel overhung. Two bearings on base. Furnished in sizes 122 to 600 inclusive. Single inlet only.

### ARRANGEMENT No. 9, SWSI

For belt drive. Arrangement No. 1 designed for mounting prime mover on side of base. Furnished in sizes 122 to 600 inclusive. Single inlet only.

### SWSI - Class II

Heavier design than Class I. A one piece intermediate stiffening ring is also welded into each blade. Tip speed limit approximately 13000 FPM and 6 inches total pressure.

## STANDARD MOTOR POSITIONS

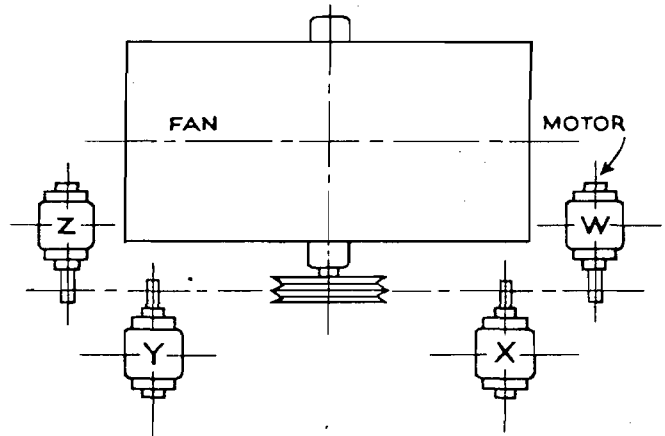

The location of motor is determined from plan view of the blower, designating the motor position by letters W, X, Y and Z as the case may be.

## CONSTRUCTION FEATURES

- HOUSING—All P.V.C.
- WHEEL—P.V.C. and Coated Steel
- INLET—1½" P.V.C. Angle Flange
- OUTLET—1½" P.V.C. Angle Flange
- DRAIN—2" P.V.C. Flanged
- CLEANOUT DOOR—P.V.C. Bolted
- STEEL FRAME—Epoxy Coated

Blowers are very rugged with heavy angle iron bracing, over capacity shaft and bearings. Formed P.V.C. venturi inlets give streamlined flow into the wheel with its own matching cone for very high efficiency and quiet operation. OPERATING TEMPERATURES UP TO 155°F.







MEET YOUR  
**POLLUTION  
 CONTROL**  
 REQUIREMENTS  
 WITH THE LEADER IN  
**PVC** FABRICATIONS



# Duall

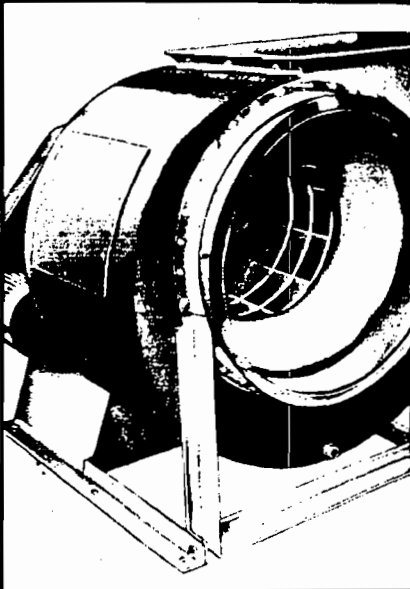

CONTROLLED ENVIRONMENTS FOR INDUSTRY  
 P. O. BOX 10428 • 804/396-7733  
 JACKSONVILLE, FLORIDA 32247-0428  
 DANIEL J. KLOS

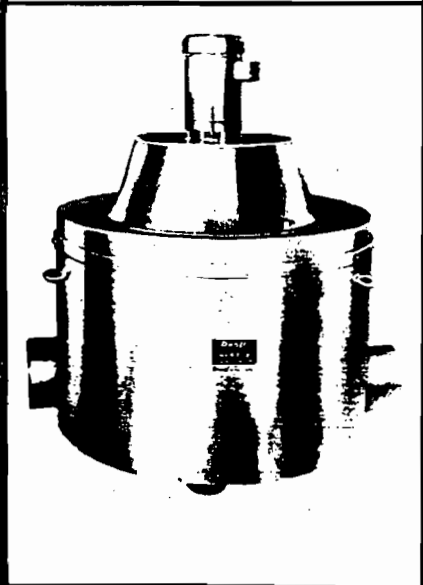

**PVC CONSTRUCTED**  
 FUME SCRUBBERS  
 CENTRIFUGAL FANS  
 DUCTING and HOODS  
 OIL MIST COLLECTORS  
 COMPLETE SYSTEMS

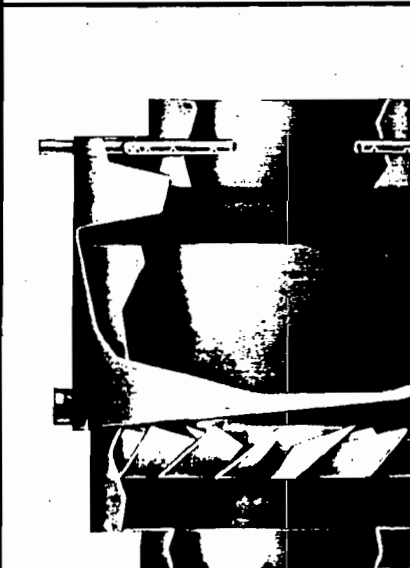

**Duall**  
 INDUSTRIES, INC.

700 S. McMillan Street • Owosso, Michigan 48867  
 Phone (517) 725-8184 • Telex 228-532

P. O. Box 1000 • 102 Hillside Drive  
 Forest City, N.C. 28043 • (704) 245-8725

# Duall

## Fume Scrubbers in 6 Types

### F-101 SERIES



Single Pack

Double Pack

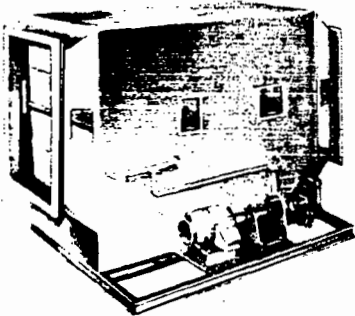

### FW-300 SERIES



Single Pack

Double Pack



### PT-500 SERIES

Single Pack

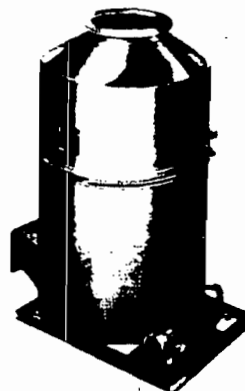

Double Pack

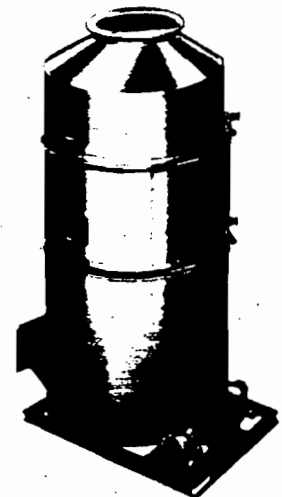

Duall Single Pack (four Stage) Fume Scrubbers solve most industrial air pollution problems. They are especially effective on water soluble fumes and odors, or with pH control on many low soluble contaminants.

Some typical proven applications are:

- Acid fumes.
- Plating fumes.
- Cleaning fumes.
- Lab hood fumes.
- Anodizing fumes.
- Pickling fumes.
- Rust-proofing fumes.
- Die-casting fumes.
- Water soluble odors.

Duall Single Pack Fume Scrubbers incorporate these advantages:

- Low cost.
- Low maintenance.
- Low water consumption.
- Low static pressure drop.
- 100% corrosion resistant.

Duall Double Pack (six stage) Fume Scrubbers offer the broadest range of answers to industrial air pollution problems. By double scrubbing the air these scrubbers provide maximum efficiency on tough fumes and odors which can not be completely absorbed in a single pack type scrubber.

Duall's Double Pack Scrubbers have proven effective on the following typical applications:

- Bright dip fumes.
- Strip tank fumes.
- Etching fumes.
- Most low solubility fumes and odors.

Our Double Pack Fume Scrubbers offer all the advantages of the Single Pack units as well as the broadest range of applications.

All Duall Fume Scrubbers can be modified for custom installation with multiple packs or extended depth packs. Multiple modular units are available for capacities larger than standard.

*See page 6 for complete specs and performance data.*

# F-101 HORIZONTAL SINGLE FILTER PACK

Being our most popular scrubber design, this compact 100% corrosion resistant P.V.C. unit has proven its efficiency nationwide. The Dual F-101 incorporates high efficiency, low maintenance filter media and the open orifice type spray nozzles, for the assurance of a thoroughly saturated collection chamber. Our mist eliminator outlet section gives four air direction changes to properly remove the entrained moisture. Where a horizontal installation is preferred, the F-101 should be your choice.

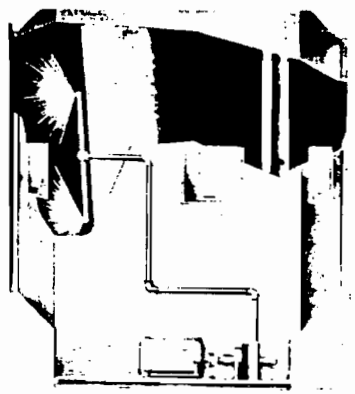

CFM in 000's	DIMENSIONS IN INCHES										CFM in 000's	DIMENSIONS IN INCHES									
	A	B	C	D	E	H	I	Q	¢	A		B	C	D	E	H	I	Q	¢		
0.5	18	10	10	49	30	10	10	37	21		20	88	61	72	66	87	61	72	46	52 1/2	
1	22	14	14	50	34	14	14	38	23		22	97	61	81	66	87	61	81	46	52 1/2	
2	28	20	20	50	40	20	20	38	26		24	104	61	88	66	87	61	88	46	52 1/2	
3	32	24	24	51	44	24	24	39	28		26	112	61	96	66	87	61	96	46	52 1/2	
4	37	29	29	52	49	29	29	40	30 1/2		28	123	61	107	66	87	61	107	46	52 1/2	
5	41	33	33	52	53	33	33	40	32 1/2		30	135	61	119	66	87	61	119	46	52 1/2	
6	45	37	37	53	58	37	37	41	35 1/2		35	157	61	141	66	87	61	141	46	52 1/2	
8	52	44	44	54	65	44	44	42	39		40	179	61	163	66	87	61	163	46	52 1/2	
10	58	46	46	59	71	46	46	43	42		45	102	61	186	66	87	61	186	46	52 1/2	
12	64	52	52	60	77	52	52	44	45		50	224	61	208	66	87	61	208	46	52 1/2	
14	69	57	57	60	82	57	57	44	47 1/2		55	247	61	231	66	87	61	231	46	52 1/2	
16	74	62	62	61	87	62	62	45	50		60	269	61	253	66	87	61	253	46	52 1/2	
18	81	65	65	61	91	65	65	45	52 1/2											52 1/2	

• Larger sizes on request.

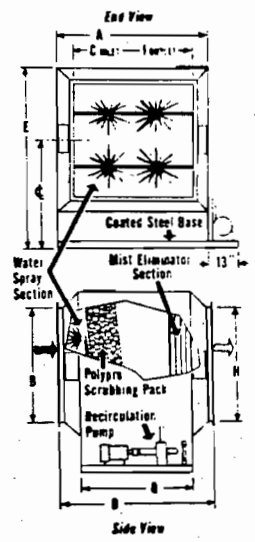

# F-101D HORIZONTAL DOUBLE FILTER PACK

An extra heavy duty scrubber for real "tuffies". It incorporates two filter packs with two sets of sprays for more thorough scrubbing... plus an effective mist eliminator at the air outlet. Serious concentrations of rough fumes, such as nitric, hydrofluoric, and hydrochloric acid are double scrubbed through six stages for maximum efficiency. Use this high efficiency fume scrubber, at only a small increase in price.

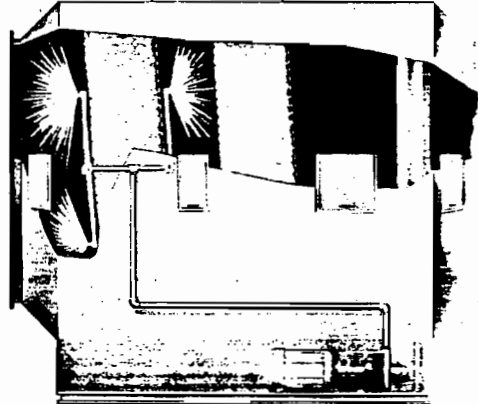

CFM in 000's	DIMENSIONS IN INCHES										CFM in 000's	DIMENSIONS IN INCHES									
	A	B	C	D	E	H	I	Q	¢	A		B	C	D	E	H	I	Q	¢		
0.5	18	10	10	70	30	10	10	58	21		20	88	61	72	87	91	61	72	67	52 1/2	
1	22	14	14	71	34	14	14	59	23		22	97	61	81	87	91	61	81	67	52 1/2	
2	28	20	20	71	40	20	20	59	26		24	104	61	88	87	91	61	88	67	52 1/2	
3	32	24	24	72	44	24	24	60	28		26	112	61	96	87	91	61	96	67	52 1/2	
4	37	29	29	73	49	29	29	61	30 1/2		28	123	61	107	87	91	61	107	67	52 1/2	
5	41	33	33	73	53	33	33	61	32 1/2		30	135	61	119	87	91	61	119	67	52 1/2	
6	45	37	37	74	58	37	37	62	35 1/2		35	157	61	141	87	91	61	141	67	52 1/2	
8	52	44	44	75	65	44	44	63	39		40	179	61	163	87	91	61	163	67	52 1/2	
10	58	46	46	80	71	46	46	64	42		45	202	61	186	87	91	61	186	67	52 1/2	
12	64	52	52	81	77	52	52	65	45		50	224	61	208	87	91	61	208	67	52 1/2	
14	69	57	57	81	82	57	57	65	47 1/2		55	247	61	231	87	91	61	231	67	52 1/2	
16	74	62	62	82	87	62	62	66	50		60	269	61	253	87	91	61	253	67	52 1/2	
18	81	65	65	82	91	65	65	66	52 1/2											52 1/2	

• Larger sizes on request.

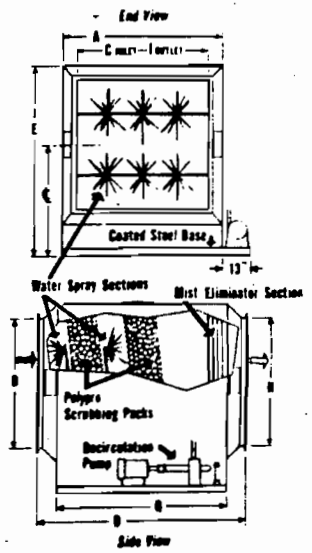



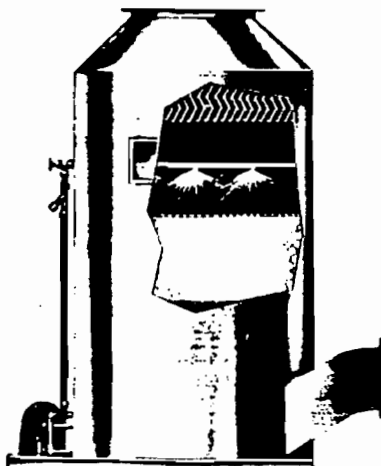
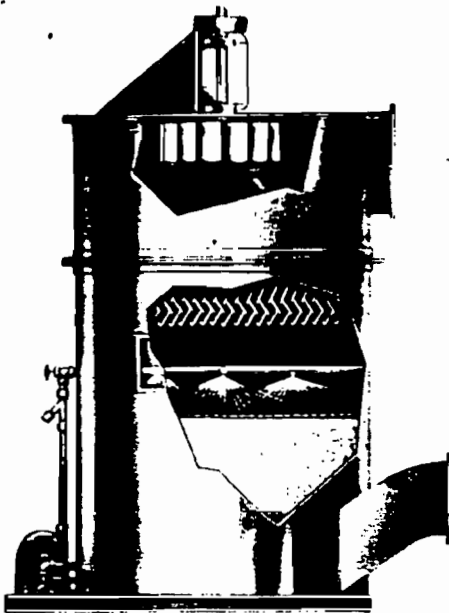

# Duall INDUSTRIES

PVC Constructed, 100% Corrosion Free

## FUME SCRUBBERS

### FW-300 Vertical Pack with Blower

500 TO 12,000 C.F.M. . . plus multiple installations

This packed tower type scrubber is not only a space saver, it's also a true economy model. It incorporates a built-in rugged fan with convenient exterior, belt driven, TEFCBB motor. During installation, the horizontal air discharge can be swivelled 360° before sealing into permanent position. Efficiency is equal to the F-101 and the PT-500. Compactness and versatility make it an unusually popular model. This FW-300 saves three ways . . . in initial cost, installation, and in space. Also available with double pack.

### F-101 Horizontal Single Filter Pack

500 TO OVER 60,000 C.F.M. . . plus multiple installations

Being our most popular scrubber design, this compact 100% corrosion resistant P.V.C. unit has proven its efficiency in 46 states. The Duall F-101 incorporates high efficiency, low maintenance filter media and the open orifice type spray nozzles, for the assurance of a thoroughly saturated collection chamber. Our mist eliminator outlet section gives four air direction changes to properly remove the entrained moisture. Where a horizontal installation is preferred, the F-101 should be your choice.

### F-101-D Horizontal Double Filter Pack

500 TO OVER 60,000 C.F.M. . . plus multiple installations

An extra heavy duty scrubber for real "tuffies". It incorporates two filter packs with two sets of sprays for more thorough scrubbing . . . plus an effective mist eliminator at the air outlet. Serious concentrations of rough fumes, such as nitric, hydrofluoric, and hydrochloric acid are double scrubbed through six stages for maximum efficiency. For such problems in your plant, use this high efficiency fume scrubber, at only a small increase in price.

### PT-500 Vertical Pack

500 TO OVER 30,000 C.F.M. . . plus multiple installations

The upright PT-500 is the space saver. This scrubber is a vertical packed tower type designed to fit into restricted spaces where floor space is at a premium. Its efficiency is equal to the F-101, and also 100% corrosion-free. Air flow is up through a thoroughly water saturated bed of filter media. The mist eliminator pack near the top outlet assures properly dried air. If space is your problem, take a good look at the PT-500. Also available with double pack.

**Duall**  
INDUSTRIES, INC.

770 South McMillan St.  
Owosso, Michigan 48867  
Telephone (517) 725-8184  
Telex 228-532

P.O. Box 100  
Forest City N.C. 28043  
Telephone (704) 243-672

# Duall FUME SCRUBBERS

## SPECIFICATIONS and PERFORMANCE DATA

### DESCRIPTIONS

**F-101:** Horizontal (cross-flow), four stage, wet scrubber. This model has maximum efficiency on water soluble contaminants and odors but is also effective on low soluble contaminants with the use of chemical neutralizers.

**F-101D:** Horizontal (cross-flow), six stage, wet scrubber. The F-101D is especially designed for use on stubborn low solubility contaminants or where extremely high scrubbing efficiency is required on normal contaminants.

**FW-300:** Vertical (counter-flow), four stage, wet scrubber with integral blower. Efficiency is equal to the F-101.

**FW-300D:** Vertical (counter-flow), six stage, wet scrubber with integral blower. Efficiency is equal to the F-101D.

**PT-500:** Vertical (counter-flow), four stage, wet scrubber. Efficiency is equal to the F-101.

**PT-500D:** Vertical (counter-flow), six stage, wet scrubber. Efficiency is equal to the F-101D.

All Duall Fume Scrubbers are constructed of P.V.C. and Polypropylene corrosion resistant materials and include a rugged coated steel base with lifting luggs. All above units are available with extended depth packing.

### SCRUBBING PRINCIPLES

Contaminant removal is accomplished by first slowing the fumes to a velocity below 500 fpm and then passing the fumes through two scrubbing stages in the single pack models and four stages in the double pack types. The fumes first pass through a water spray or curtain during which a percentage of the larger contaminant particles drop out and the remaining fumes are saturated. The second stage consists of a 12" deep pack of polypropylene high surface, non-clogging, spherical plate packing media\* which is continuously wetted by the spray nozzles. The saturated fumes are impinged upon the packing and the contaminants are absorbed and carried away in the wash water. The first and second stages are repeated in the double pack fume scrubbers.

\*Several types of alternate packing media are available on request.

### MIST ELIMINATION

After passing through the scrubbing sections, the air is moisture laden and must pass through a two stage gravity mist eliminator section. This final stage of P.V.C. eliminator blades provides four 30° changes in direction and eliminates entrained water.

### WATER SUPPLY

All Duall Fume Scrubbers may be supplied with water either directly from your supply or from an integral or remote recirculation system supplied with the scrubber. It is generally recommended that a recirculation system be used to conserve water except on very low cfm units. The actual fresh water consumption on the single pack series with recirculation is only 0.05 to 0.15 gpm/1000 cfm depending on the contaminant involved. On the double pack models, water consumption ranges from 0.1 to 0.3 gpm/1000 cfm. This represents 5% of the water being recirculated. Duall scrubbers are self-draining and may be installed out-doors in sub-zero conditions without freeze-up. If these conditions exist, a remote recirculation system should be specified for placement in a heated area.

All Duall Scrubbers come complete with fittings for the addition of chemical neutralizers, if required. A complete chemical metering and pumping system is available upon request.

### MATERIALS

Every Duall Fume Scrubber is shipped complete with an integral coated steel base. No special mounting is required. Simply connect the duct, the water and power supply, and the unit is ready for operation. Complete installation and operating instructions are supplied with all Duall Scrubbers.

### PRESSURE DROP

The following pressure drops are applicable for Scrubbers operated at design CFM:

<b>E-101</b>	2.0" w.g.	<b>FW-300D</b>	3.0" w.g.
<b>F-101D</b>	3.0" w.g.	<b>PT-500</b>	2.0" w.g.
<b>FW-300</b>	2.0" w.g.	<b>PT-500D</b>	3.0" w.g.

On the FW-300 series, the blower is designed for 2.0" external static pressure.

### FW-300 BLOWER SECTION

The top section of the FW-300 Fume Scrubber consists of a Duall P.V.C. centrifugal blower complete with motor and OSHA belt guard and shaft cover. The blower section may be rotated through 360° to obtain any desired angle between scrubber inlet and blower outlet. This blower section is same low maintenance, guaranteed corrosion resistant blower described in Duall Brochure No. CI-131, and NH-151.

### MAINTENANCE

All Duall Fume Scrubbers incorporate low maintenance components from front to back, including the packing, plumbing system and eliminators. Quick opening inspection doors are at all critical points.

DUALL FUME SCRUBBERS Typical Average Fume Removal Efficiencies				
MODELS▶	Single Pack Series: F-101 PT-500 FW-300	Double Pack Series: F-101D PT-500D FW-300D	Single Pack Series: with added Chemical Neutralizer (pH Control)	Double Pack Series:
CONTAMINATES ▼				
Acetic Acid	95-98	98-99	—	—
Alkaline Cleaners	96-99	98-99	—	—
Aluminum Bright Dip*	80-85	85-90	—	—
Anodizing	96-99	98-99	—	—
Aqua Regia	80-85	85-90	85-90	90-95
Boric Acid	85-90	90-95	—	—
Caustic Cleaners	98-99	99	—	—
Caustic Soda	98-99	99	—	—
Chlorine	80-85	85-90	85-90	90-95
Chromic Acid	98-99	99	—	—
Copper Chloride	75-80	80-85	85-90	90-95
Cyanide Solutions	98-99	99	—	—
Ferric Chloride	80-85	83-88	—	—
Ferric Nitrate	96-98	98-99	—	—
Ferrous Chloride	90-95	95-98	—	—
Ferrous Sulfate	95-97	96-98	—	—
Fluosilicic Acid	95-98	98-99	—	—
Hydrochloric Acid	80-85	85-90	90-95	95-98
Hydrogen Cyanide	85-90	90-95	—	—
Hydrofluoric Acid	90-93	95-98	—	—
Hydrofluosilicic Acid	95-98	98-99	—	—
Hydrogen Peroxide	90-95	95-99	—	—
Hydrogen Sulfide	70-75	75-80	85-90	95-98
Nickel Chloride	80-85	85-90	90-95	95-98
Nickel Sulfate	80-85	85-90	90-95	95-98
Nitric Acid	75-80	85-90	—	—
Nitrogen Dioxide (NO <sub>2</sub> )	45-50	50-60	65-70	70-75
Nitric — HF Acid	75-80	85-90	—	—
Perchloric Acid	95-98	96-99	—	—
Phosphoric Acid	96-99	98-99	—	—
Potassium Dichromate	96-98	98-99	—	—
Selenium Sulfide	96-98	98-99	—	—
Sodium Chloride	96-98	98-99	—	—
Sodium Fluoride	90-95	95-98	—	—
Sodium Glutamate	96-98	98-99	—	—
Sodium Hydroxide	98-99	99	—	—
Sulfur Dioxide	70-75	75-80	80-85	85-90
Sulfuric Acid	96-98	98-99	—	—
Tin Chlorides	75-80	80-85	85-90	90-95
Zinc Chloride	75-80	80-85	—	—
Zinc Nitrate	96-98	98-99	—	—
Zinc Sulfate	96-98	98-99	—	—

\* These efficiencies are for the combined nitric and phosphoric fume. The efficiency for the NO<sub>2</sub> portion of the fume only will be as listed above.

● The above efficiencies are intended as guide representing average values. Specific combinations and concentrations of fumes may result in a significant variation from the above.



May 11, 1990

Mr. Bruce Mitchell  
Engineer  
Bureau of Air Quality Management  
Florida Department of Environmental Regulation  
Twin Towers Office Building  
2600 Blair Stone Road  
Tallahassee, FL 32399-2400

RECEIVED  
MAY 15 1990  
DER-BAQM

Re: Exhaust system modification; Permit No. AC 05-168460  
Building 63

158237

Dear Mr. Mitchell:

Pursuant to our phone conversation last week, the purpose of this letter is to provide the Department with additional information on the equipment proposed to be attached to building 63 scrubber no. F63S02 once scrubber no. F63S01 is deactivated. As outlined in the letter of notification sent to the State on April 7th, the phase-out of the building's wafer fabrication area has resulted in the removal of numerous pieces of exhausted equipment (see attachment I.)

Attachment II contains a list of the equipment attached to scrubbers F63S01 and F63S02 prior to the shut-down of the fabrication area. Attachment III is a list of equipment currently ducted to the two scrubbers. All exhausted equipment in the VHSIC wafer fabrication area has been removed with the exception of an ion implanter, two acid stations, a vapor deposition furnace and the gas cabinets and vacuum pump that service it. These pieces of equipment will be ducted to scrubber F63S02. The scrubber will also continue to service one of the building's two assembly areas.

It should be noted that the vapor deposition furnace and the associated gas cabinets and vacuum pump are scheduled to be removed sometime this month.

If you have any further questions, please call me at (407) 729-4061.

Sincerely,

*Nancy Baldisserotto*

Nancy Baldisserotto  
Senior Environmental Engineer

**ATTACHMENT I.**



April 7, 1990

Mr. Claire Fancy  
Bureau Chief  
Bureau of Air Regulation  
Florida Department of Environmental Regulation  
Twin Towers Office Building  
2600 Blair Stone Road  
Tallahassee, FL 32399-2400

Re: Exhaust system modification; Permit No. AC 05-168460  
Building 63 Consolidated Air Permit

Dear Mr. Fancy:

By this letter, Harris Semiconductor is providing the Department with notice of the phase-out of one of our wafer fabrication areas. Prior to January of 1990, one of the primary processes occurring in Building 63 was wafer fabrication. The VHSIC wafer fabrication area employed a series of manufacturing procedures that utilized a variety of manufacturing equipment and chemicals in order to produce the desired product. During the late months of 1989, the area was shut down, and wafer fabrication in this building was discontinued. Exhausted Equipment removed included aligners, developers, coaters, furnaces, wet stations, burn boxes, chemical and gas cabinets, vacuum pumps, and chemical drains.

The two scrubbers that handled equipment exhaust from Building 63's wafer fab were F63S01 and F63S02. The systems are located on the east side of the building at ground level. F63S01 provided exhaust and pollution control for acid exhaust drawn from the equipment in the wafer fab and chemical mix room, while F63S02 provided solvent exhaust for the fab, the chemical mix room, and one of the assembly areas.

Prior to the phase-out of the Building 63 fab, equipment requiring approximately 27,000 cfm of exhaust was ducted to scrubber nos. F63S01 and F63S02.

Scrubber no. F63S02 is a Beverly Pacific 10,000 scfm vertical counter-current scrubber. The system has adequate capacity to handle the remaining equipment, which requires only 3,000 cfm of exhaust.

If the Department has no objection, we will be deactivating scrubber no. F63S01 sometime this month. If you have any questions, please give me a call at (407)729-4061.

Sincerely,

  
Nancy Baldisserotto  
Senior Environmental Engineer  
Harris Semiconductor

cc: B. Mitchell  
C. Collins

**ATTACHMENT II.**

SCRUB #	ENV_ID	EQUIP_TYPE	AREA	CFM	EQUIP_ID	CHEM1
F63S01	0801	ALIGNER PE-540	P63F04 ALLIGNMT	100	H910369	(HG BULB)
	0802	ALIGNER SRA 100	F63F04 ALLIGNMT	100	H120979	(HG BULB)
	0803	ULTRASTEP 1100	P63F04 ALLIGNMT	100	N/A	(HG BULB)
	0806	MICROLITE DEEP UV	P63F04 PHOTORESIST	250	H121150	OZONE
	0807	MICROLITE DEEP UV	P63F04 PHOTORESIST	250	H121150	OZONE
	0808	SOLITEC COATER	P63F04 PHOTORESIST	250	H121229	ECX 1030 PHOTORESIST
	0811	4' ACID STN	P63F04 PHOTORESIST	600	H120973	MF 319 DEVELOP MF 320 DEVELOP SHIPLEY MICROPOSIT PIRANHA
	0815	6' ACID STN	P63F04 ETCH	900	H120972	HF 10:1
	0816	8' ACID STN	P63F04 ETCH	1200	H123807	HF 40:1
	0817	MTI STRIPPER	P63F04 ETCH	10	N/A	NITROUS OXIDE OXYGEN
	0818	AME 8100 ETCH	P63F04 ETCH	180	N/A	ARGON OXYGEN TRIFLUOROMETHANE
	0819	AME-8100 ETCHER	P63F04 ETCH	200	H121181	ARGON CHLORINE NITROGEN TRIFLUORIDE OXYGEN TRIFLUOROMETHANE
	0820	ET PLASMAFAB STRIP	P63F04 ETCH	0		CARBON TETRAFLUORIDE OXYGEN
	0821	APPLIED MAT'L ETCHER	P63F04 ETCH	150	H125035	BORON TRICHLORIDE CARBON TETRAFLUORIDE CHLORINE TRIFLUOROMETHANE
	0822	AME 8100 ETCHER	P63F04 ETCH	200	H120427	ARGON CARBON TETRAFLUORIDE NITROGEN TRIFLUORIDE OXYGEN
	0823	AME 8100 ETCHER	P63S04 ETCH	200	H120426	OXYGEN TRIFLUOROMETHANE
	0824	AME-8100 ETCHER	P63F04 ETCH	200	H120425	BORON TRICHLORIDE CHLORINE HYDROCHLORIC ACID NITROGEN OXYGEN
	0825	9' ACID HOOD	P63F04 THIN FILM	750	H120953	ALUMINUM ETCH HYDROCHLORIC ACID HYDROGEN PEROXIDE TUNGSTEN ETCH
	0826	5' ACID HOOD	P63F04 THIN FILM	900	N/A	WATER HF 100% HF 40% PIRANHA
	0827	ASH PECVD	P63F04 THIN FILM	550	H123808	AMMONIA ARGON, NITROGEN DIBORANE DICHLOROSILANE NITROUS OXIDE

SCRUB_#	ENV_ID	EQUIP_TYPE	AREA	CFM	EQUIP_ID	CHEM1
-----	-----	-----	-----	---	-----	-----
F63S01	0827	ASM PECVD	P63F04 THIN FILM	550	H123808	OXYGEN PHOSPHINE SILANE
	0828	THERMCO MINI-BRUTE	P63F04 THIN FILM	200	H120955	ARGON FORMING GAS
	0829	ANICON WCVD	P63F04 THIN FILM	700	H121155	ARGON HYDROGEN NITROGEN TRIFLUORIDE SILANE TUNGSTEN HEXAFLUORIDE
	0830	PE 4480 AL SPUTTER	P63F04 THIN FILM	0	H121145	ARGON NITROGEN
	0831	MTI SYPHERLINE	P63F04 THIN FILM	40	N/A	ARGON NITROGEN
	0832	ACID STOR CAB	F63F04 CHASE	50	N/A	CHLOROSULFONIC ACID HF 40:1 HYDROGEN PEROXIDE NITRIC ACID OXIDE ETCH 11:1 SEL-REX SULFURIC ACID
	0833	ACID STOR CAB	P63F04 CHASE	50	N/A	ALUM PREDIP ETCH OXIDE ETCH 11:1 SULFURIC ACID
	0834	ACID STOR CAB	P63F04 CHASE	50	N/A	HF 100% HF 10:1 HF 50:1 NITRIC ACID POLYSILICON ETCH
	0835	SOLV STOR CAB	P63F04 CHASE	50	N/A	2-ETHOXYETHANOL CELLUSOLVE ACETATE ETHANOL MEK, IPA, HMDS 10% PPD-400 DEVELOPER SHIPLEY MF 320 DEVELOP SHIPLEY MICROPOSIT DEV TOYO SODA
	0836	SOLV STOR CAB	P63F04 CHASE	50	N/A	SHIPLEY S1400-27 PR SHIPLEY S1400-DI
	0837	SOLV STOR CAB	P63F04 CHASE	50	N/A	ACETONE SHIPLEY MF 319 DEVELOP SHIPLEY MICROPOSIT THIN
	0838	GAS CAB	P63F04 CHASE	50	N/A	NITROGEN NITROGEN TRIFLUORIDE
	0839	GAS CAB (DBL)	P63F04 CHASE	75	N/A	HALOCARBON 23 NITROGEN
	0840	GAS CAB (DBL)	P63F04 CHASE	100	N/A	FREON 14 NITROGEN
	0841	GAS CAB (DBL)	P63F04 CHASE	100	N/A	AMMONIA HYDROGEN
	0842	GAS CAB	P63F04 CHASE	75	N/A	NITROGEN NITROUS OXIDE



SCRUB #	ENV_ID	EQUIP_TYPE	AREA	CFM	EQUIP_ID	CHEM1
F63S01	0843	GAS CAB (DBL)	P63F04 CHASE	100	N/A	NITROGEN
	0844	GAS CAB (DBL)	P63F04 CHASE	100	N/A	OXYGEN ARGON FREON 23
	0845	GAS CAB	P63F04 CHASE	75	N/A	NITROGEN DICHLOROSILANE
	0846	GAS CAB (DBL)	P63F04 CHASE	100	N/A	NITROGEN
	0847	GAS CAB (DBL)	P63F04 CHASE	100	N/A	NITROGEN OXYGEN ARGON FREON 23
	0848	GAS CAB (DBL)	P63F04 CHASE	100	N/A	NITROGEN ARGON PHOSPHINE 100% SILANE 100%
	0849	GAS CAB (DBL)	P63F04 CHASE	100	N/A	ARGON HYDROGEN
	0850	GAS CAB	P63F04 CHASE	75	N/A	NITROGEN
	0851	GAS CAB	P63F04 CHASE	75	N/A	NITROGEN PHOSPHINE
	0852	GAS GAS (DBL)	P63F04 CHASE	100	N/A	NITROGEN SILANE
	0853	GAS CAB (DBL)	P63F04 CHASE	100	N/A	OXYGEN CARBON TETRAFLUORIDE HALOCARBON 14
	0854	GAS CAB (DBL)	P63F04 CHASE	100	N/A	NITROGEN TRIFLUORIDE ARGON HALOCARBON 23
	0855	GAS CAB (DBL)	P63F04 CHASE	100	N/A	OXYGEN
	0856	GAS CAB (DBL)	P63F04 CHASE	100	N/A	NITROGEN CHLORINE
	0857	GAS CAB (DBL)	F63F04 CHASE	100	N/A	NITROGEN TRIFLUORIDE ARGON HYDROCHLORIC ACID
	0858	GAS CAB	P63F04 CHASE	75	N/A	CHLORINE
	0859	VAC PUMP	P63F04 CHASE	5	N/A	NITROGEN
	0860	VAC PUMP	P63F04 CHASE	5	N/A	ARGON NITROGEN
	0861	VAC PUMP	P63F04 CHASE	5	N/A	ARGON
	0862	VAC PUMP	P63F04 CHASE	5	N/A	NITROGEN
	0863	VAC PUMP	P63F04 CHASE	5	N/A	ARGON
	0864	GAS CAB	P63F04 CHASE	75	N/A	BORON TRICHLORIDE
	0865	VAC PUMP	P63F04 CHASE	5	N/A	ARGON
	0866	VAC PUMP	P63F04 CHASE	5	N/A	NITROGEN
	0867	VAC PUMP	P63F04 CHASE	5	N/A	ARGON
	0868	GAS CAB	P63F04 CHASE	75	N/A	NITROGEN
	0871	VAC PUMP	P63F04 CHASE	5	N/A	ARGON
	0872	VAC PUMP	P63S04 CHASE	5	N/A	NITROGEN
	0874	VAC PUMP	P63F04 CHASE	5	N/A	OIL VAPORS
	0875	VAC PUMP	P63F04 CHASE	5	N/A	OIL VAPORS

SCRUB #	ENV_ID	EQUIP_TYPE	AREA	CFM	EQUIP_ID	CHEM1
F63S01	0877	FSI CONSOLE	P63F03 CHASE	650	N/A	
	0901	FSI 3000 SATURN	P63F03 DIFFUSN	150	N/A	125:1 HF HYDROCHLORIC ACID HYDROGEN PEROXIDE SULFURIC ACID
	0902	FSI 2800	P63F03 DIFFUSN	150	N/A	125:1 HF HYDROCHLORIC ACID HYDROGEN PEROXIDE SULFURIC ACID
	0903	FURNACE BANK	P63F03 DIFFUSN	1000	H120428	HYDROGEN NITROGEN OXYGEN TCA
	0904	FURNACE BANK	P63F03 DIFFUSN	1000	H120429	HYDROGEN NITROGEN OXYGEN TCA
	0905	FURNACE BANK	P63F03 DIFFUSN	1000	N/A	HYDROCHLORIC ACID OXYGEN PHOSPHINE 100% SILANE
	0907	GAS CAB (DBL)	F63F03	100	N/A	NITROGEN
	0908	GAS CAB (DBL)	F63F03	100	N/A	ARGON OXYGEN
	0909	GAS CAB (DBL)	F63F03	100	N/A	NITROGEN OXYGEN
	0910	GAS CAB (DBL)	P63F03	100	N/A	HYDROCHLORIC ACID NITROGEN
	0911	ACID STOR CAB	P63F03	50	N/A	AMMONIUM HYDROXIDE HYDROGEN PEROXIDE POTASSIUM HYDROXIDE
	0912	SOLV STOR CAB	P63F03	50	N/A	ACETONE ALILITH CHEMICAL STRIP ETHANOL MICROPOSIT MF-312 DEV MIK
	0913	TUBE CLEAN	P63F03	1800	H120980	HF NITRIC ACID
	0914	FIXTURE CLEAN	P63F03	500	H122313	HF
	0915	ATCDR BOX WASH	P63F03	300	N/A	WATER ONLY
	0916	GAS CAB (DBL)	P63F03	100	N/A	PHOSPHINE 6% SILANE 100%
	0917	GAS CAB (DBL)	P63F03	100	N/A	HYDROGEN
	0918	GAS CAB	P63F03	75	(VF 17)	DICHLOROSILANE
	0919	GAS CAB (S)	P63F03	75	(VF 18)	SILANE
	0920	GAS CAB	P63F03	75	(VF 7)	PHOSPHINE
	0921	GAS CAB	P63F03	75	(VF 19)	5% PHOSPHINE/SILANE
	0924	3' ACID STN	P63F02 CHEM MIX	450	N/A	NITRIC ACID
	0925	4' SOLV STN	P63F02 CHEM MIX	450	N/A	POTASSIUM HYDROXIDE
	0926	6' ACID STN	P63F02 CHEM MIX	1500	N/A	HF
	0927	5' SOLV STN	P63F02 CHEM MIX	700	N/A	ACETONE ISOPROPANOL

SCRUB #	ENV_ID	EQUIP_TYPE	AREA	CFM	EQUIP_ID	CHEM1
F63S01	0927	5' SOLV STN	P63F02 CHEM MIX	700	N/A	METHANOL
	0928	3' SOURCE CLEAN STN	P63F02 CHEM MIX	450	N/A	ACHESON MOLYDAG 210
	0960	2' ACID STN	P63F05 PC PARTS PREP	200	N/A	HYDROCHLORIC ACID
	0965	DIE ATTACH	P63F05 ENGR LAB	500	N/A	CERRIC SULFATE NITRIC ACID
F63S02	0809	6' SOLV STN	P63F04 PHOTORESIST	900	H120994	ACETONE IPA
	0810	SOLITEK DEVELOPER	P63F04 PHOTORESIST	100	N/A	
	0812	SVG DEVELOPER	P63F04 PHOTORESIST	150	H120423	MF 319 DEVELOP
	0813	SVG COATER	P63F04 PHOTORESIST	200	H120424	HMDS SHIPLEY 1400 PHOTORESIST
	0814	SVG COATER	P63F04 PHOTORESIST	200	H123806	AZ 5214 PHOTORESIST ECX 1030 PHOTORESIST HMDS SHIPLEY 1400 PHOTORESIST
	0869	CHEM STOR CAB	P63F04	50	N/A	ACETONE IPA SHIPLEY MICROPOSIT PR THINNER A
	0870	MICROSTRIP DISPENSE	P63F04 CHASE	0	N/A	MICROSTRIP
	0873	CHEM CANISTER	P63F04 CHASE	-0	N/A	EPA SOLVENT HMDS
	0906	ION IMPLANTER	P63F03 DIFFUSN	900	H120430	ARSENE BORON PHOSPHINE
	0930	5' SOLV CLEAN STN	F63F01 ENVIRO	750	H916216	ACETONE FREON TF IPA
	0931	CENTRI CENTRIFUGE	P63F01 ENVIRO	0	H915506	NONE USED
	0933	CLEAN/DRY STN	P63F01 ASSEMBLY	0	N/A	IPA
	0934	CLEAN/DRY STN	P63F01 ASSEMBLY	0	N/A	IPA
	0935	CLEAN/DRY STN	P63F01 ASSEMBLY	0	N/A	IPA
	0936	CLEAN/DRY STN	P63F01 ASSEMBLY	0	N/A	IPA
	0937	ULTRATECH DIE WASH	P63F01 DIE AREA	100	H915436	WATER
	0938	4' SOLV CLEAN STN	P63F01 DIE AREA	450	H916215	IPA
0939	ULTRATECH DIE WASH	P63F01 PARTS PREP	100	H914970	CARBON DIOXIDE WATER	
0940	BREAK/SDRT STN	P63F01 PARTS PREP	0	N/A	FREON TF	
0941	BRANSON DEGREASER	P63F01 PARTS PREP	300	H914872	FREON TF	

**ATTACHMENT III.**

SCRUB #	ENV_ID	EQUIP_TYPE	AREA	CFM	EQUIP_ID	CHEM1
F63S02	0825	9' ACID HOOD	P63F04 THIN FILM	750	H120953	ALUMINUM ETCH HYDROCHLORIC ACID HYDROGEN PEROXIDE TUNGSTEN ETCH WATER
	0826	5' ACID HOOD	P63F04 THIN FILM	900	N/A	HF 100% HF 40% PIRANHA
	0846	GAS CAB (DBL)	P63F04	100	N/A	NITROGEN OXYGEN
	0847	GAS CAB (DBL)	P63F04 CHASE	100	N/A	ARGON FREON 23 NITROGEN
	0848	GAS CAB (DBL)	P63F04 CHASE	100	N/A	ARGON PHOSPHINE 100% SILANE 100%
	0849	GAS CAB (DBL)	P63F04	100	N/A	ARGON HYDROGEN NITROGEN
	0850	GAS CAB	P63F04 CHASE	75	N/A	NITROGEN PHOSPHINE
	0851	GAS CAB	P63F04	75	N/A	NITROGEN SILANE
	0860	VAC PUMP	P63F04 CHASE	5	N/A	ARGON NITROGEN
	0906	ION IMPLANTER	P63F03 DIFFUSN	900	H120430	ARSENE BORON PHOSPHINE
	0930	5' SOLV CLEAN STN	F63F01 ENVIRO	750	H916216	ACETONE FREON TF IPA
	0931	CENTRI CENTRIFUGE	P63F01 ENVIRO	0	H915506	NONE USED
	0933	CLEAN/DRY STN	P63F01 ASSEMBLY	0	N/A	IPA
	0934	CLEAN/DRY STN	P63F01 ASSEMBLY	0	N/A	IPA
	0935	CLEAN/DRY STN	P63F01 ASSEMBLY	0	N/A	IPA
	0936	CLEAN/DRY STN	P63F01 ASSEMBLY	0	N/A	IPA
	0937	ULTRATECH DIE WASH	P63F01 DIE AREA	100	H915436	WATER
	0938	4' SOLV CLEAN STN	P63F01 DIE AREA	450	H916215	IPA
	0939	ULTRATECH DIE WASH	P63F01 PARTS PREP	100	H914970	CARBON DIOXIDE WATER
	0940	BREAK/SORT STN	P63F01 PARTS PREP	0	N/A	FREON TF
	0941	BRANSON DEGREASER	P63F01 PARTS PREP	300	H914872	FREON TF



PM  
4-5-90  
Melbourne, FL  
4-6-90  
Orlando, FL

BEST AVAILABLE COPY

April 7, 1990

Mr. Claire Fancy  
Bureau Chief  
Bureau of Air Regulation  
Florida Department of Environmental Regulation  
Twin Towers Office Building  
2600 Blair Stone Road  
Tallahassee, FL 32399-2400

RECEIVED

APR 10 1990

DER-BA

158237

Re: Exhaust system modification; Permit No. AC 05-168460  
Building 63 Consolidated Air Permit

Dear Mr. Fancy:

By this letter, Harris Semiconductor is providing the Department with notice of the phase-out of one of our wafer fabrication areas. Prior to January of 1990, one of the primary processes occurring in Building 63 was wafer fabrication. The VHSIC wafer fabrication area employed a series of manufacturing procedures that utilized a variety of manufacturing equipment and chemicals in order to produce the desired product. During the late months of 1989, the area was shut down, and wafer fabrication in this building was discontinued. Exhausted Equipment removed included aligners, developers, coaters, furnaces, wet stations, burn boxes, chemical and gas cabinets, vacuum pumps, and chemical drains.

The two scrubbers that handled equipment exhaust from Building 63's wafer fab were F63S01 and F63S02. The systems are located on the east side of the building at ground level. F63S01 provided exhaust and pollution control for acid exhaust drawn from the equipment in the wafer fab and chemical mix room, while F63S02 provided solvent exhaust for the fab, the chemical mix room, and one of the assembly areas.

Prior to the phase-out of the Building 63 fab, equipment requiring approximately 27,000 cfm of exhaust was ducted to scrubber nos. F63S01 and F63S02.

Scrubber no. F63S02 is a Beverly Pacific 10,000 scfm vertical counter-current scrubber. The system has adequate capacity to handle the remaining equipment, which requires only 3,000 cfm of exhaust.

If the Department has no objection, we will be deactivating scrubber no. F63S01 sometime this month. If you have any questions, please give me a call at (407)729-4061.

Sincerely,

*Nancy Baldisserotto*  
Nancy Baldisserotto  
Senior Environmental Engineer  
Harris Semiconductor

cc: B. Mitchell  
C. Collins

4-11-90

~~BT~~  
~~BT~~ WOULD THIS BE A PERM AMENDMENT?  
BT,

FYI, Please initial and forward. Return to Patty for file.

I feel we should request info on what activity (ies) that the remaining scrubber (F63502) will service. I'll prepare a draft letter. OK

Shanks,  
Bm

BEST AVAILABLE COPY



March 12, 1990

RECEIVED

MAR 22 1990

Express Mail

DER-BAQM

Charles M. Collins, P.E.  
Program Administrator  
Air Resources Management  
Central Florida District  
Florida Department of Environmental Regulation  
3319 Maguire Blvd., Suite 232  
Orlando, Florida 32803

RE: Brevard County - AP  
Warning Notice - OWN-AP-89-0151

Dear Mr. Collins:

This letter is submitted on behalf of Harris Corporation, Semiconductor Sector ("Semiconductor") to follow-up on our letter of February 16. In that letter, it was stated that Semiconductor would, within 30 days, submit a schedule outlining the activities that will be undertaken to identify reasonable and appropriate solutions to the odor issue.

As mentioned in previous correspondence, Jacobs Engineering Group, Inc. ("Jacobs") has been retained by Semiconductor to facilitate the odor issue investigation. In a recent meeting, Jacobs recommended a revision of the suggested activities as outlined in the February 16 letter. As such, Jacobs has recommended that the odor investigation continue as follows:

Work Item One : Chemical inventory and historical stack monitoring information will be reviewed and used in a dispersion model to determine areas that may be affected by odors. This change was recommended by Jacobs as opposed to running stack analyses on all emission points from Bldg. 54. Jacobs feels that previous monitoring activities will provide the information needed for the dispersion modeling.

This item is scheduled to be completed by March 30, 1990.

Work Item Two: Through the use of an Organic Vapor Analyzer in GC mode, investigate the level of constituents present at likely "odor hot spots." These areas would be determined through the use of the computer dispersion model outlined in Work Item One.

This item is scheduled for completion by April 27, 1990.

This is the plan of action Semiconductor intends to pursue.



**BEST AVAILABLE COPY**

Subsequent to these activities, Semiconductor will submit a completed report, by May 4, 1990, detailing the information obtained during completion of the Work Items. This report will include any proposed modifications or process changes.

To supplement these activities, Semiconductor has already contracted with Air Consulting and Engineering (ACE) to conduct GC/MS sampling from one of the stacks at Building 54. The stack chosen is the most likely candidate to be contributing to the alleged odor problem. Due to the prohibitive cost of running complete analyses on all stacks (\$60,000 per stack for 24 hours of sampling as quoted by Jacobs), we chose to sample one stack for a period of 10 operating hours. This will give us total coverage of first shift activities along with 1 hour on either side of shift changes. This data will subsequently be utilized in the dispersion model to add further background information to the investigation.

In addition to these activities, Semiconductor has taken a close look at the processes within the Building 54 wafer fabrication area that may be a source of the odor issue. We are contacting our customers to determine if it may be possible to replace some of the process chemicals currently in use with substitutes that may have less potential to cause or contribute to odors at the facility. We are also continuing to review operating procedures and process configurations in order to ensure that reasonable steps have been taken in the proper control of the subject chemicals.

As indicated in my telephone conversation with Caroline Shine on March 8, Semiconductor has requested the Tallahassee DER office for an extension on the submission of appropriate operating permit applications for this facility. It does not appear worthwhile for either DER or Semiconductor to put effort into obtaining operating permits that will be ultimately denied.

Please contact me at 729-5736 if I can provide any further assistance in this matter.

Yours truly,

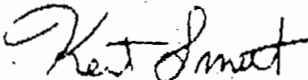

Kent Smith  
Manager, Environmental Services

cc: D. R. Erdley  
R. R. Sands  
L. R. Hutker  
J. R. Steiner

HARRIS SEMICONDUCTOR  
ENVIRONMENTAL SERVICES DEPARTMENT  
FAX TRANSMITTAL

DATE: 3/22/90

TO: B. Mitchell

FAX # (904) 487-4938

FROM: Nancy Baldisserotto

FAX # (407) 729-5153

# of pages (including cover)     

MESSAGE:

*Please call B. Mitchell  
or P. Adams  
at 8-1344.*

(407) 729-4061  
P.O. Box 883, Newbourne, FL 32901-00833  
MS 59-006

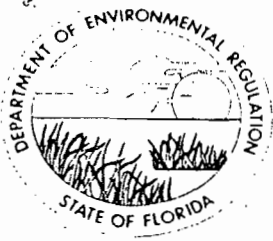

# Florida Department of Environmental Regulation

Twin Towers Office Bldg. • 2600 Blair Stone Road • Tallahassee, Florida 32399-2400

Bob Martinez, Governor

Dale Twachtman, Secretary

John Shearer, Assistant Secretary

January 8, 1990

CERTIFIED MAIL - RETURN RECEIPT REQUESTED

Mr. Kent Smith, Environmental Manager  
Harris Semiconductor  
P. O. Box 883  
Melbourne, Florida 32902-0883

Dear Mr. Smith:

Re: Amendment of Construction Permits:

AC 05-147321	Bldg. 54
-150794	59
-157786	51
-157787	62
-158237	63
-159484	58
-161706	57
-164544	55

The Department has reviewed Ms. Nancy Baldisserotto's letter received December 13, 1989, requesting that the above referenced air construction permits' expiration dates be extended. The Department is in agreement with the basic request and the following will be changed and added:

A. AC 05-147321, -150794, -157786, -157787, -158237, -159484, -161706 and -164544.

o Expiration Date

From: April 30, 1990

To: June 30, 1990

B. Attachment to be Incorporated

o Ms. Nancy Baldisserotto's letter received December 13, 1989.

Mr. Kent Smith  
Page 2  
January 8, 1990

This letter must be attached to your air construction permits, as referenced above, and shall become a part of the permits.

Sincerely,

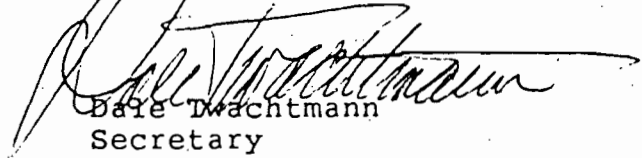

Dale Trachtmann  
Secretary

DT/plm

Attachment

c: C. Collins, Central Dist.  
N. Baldisserotto, HS

P 938 762 729

**RECEIPT FOR CERTIFIED MAIL**

NO INSURANCE COVERAGE PROVIDED  
NOT FOR INTERNATIONAL MAIL  
(See Reverse)

Sent to Mr. L. R. Hutker, Harris	
Street and No. P.O. Box 883	
P.O., State and ZIP Code Melbourne, FL 32901	
Postage	\$
Certified Fee	
Special Delivery Fee	
Restricted Delivery Fee	
Return Receipt showing to whom and Date Delivered	
Return Receipt showing to whom, Date, and Address of Delivery	
TOTAL Postage and Fees	\$
Postmark or Date Mailed: 11-1-89 Permit: AC 05-157786	

PS Form 3800, June 1985

**SENDER:** Complete items 1 and 2 when additional services are desired, and complete items 3 and 4.  
Put your address in the "RETURN TO" Space on the reverse side. Failure to do this will prevent this card from being returned to you. The return receipt fee will provide you the name of the person delivered to and the date of delivery. For additional fees the following services are available. Consult postmaster for fees and check box(es) for additional service(s) requested.

1.  Show to whom delivered, date, and addressee's address. (Extra charge)      2.  Restricted Delivery (Extra charge)

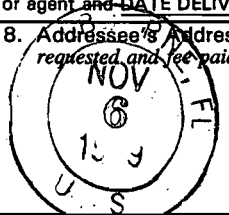
3. Article Addressed to: Mr. Lawrence R. Hutker Director, Facilities Dept. Harris Semiconductor P. O. Box 883 Melbourne, FL 32901	4. Article Number P 938 762 729
	Type of Service: <input type="checkbox"/> Registered <input type="checkbox"/> Insured <input checked="" type="checkbox"/> Certified <input type="checkbox"/> COD <input type="checkbox"/> Express Mail <input type="checkbox"/> Return Receipt for Merchandise
	Always obtain signature of addressee or agent and <b>DATE DELIVERED.</b>
5. Signature - Address X	8. Addressee's Address (ONLY if requested and fee paid)
6. Signature - Agent X <i>Harold Semulenkovich</i>	
7. Date of Delivery <i>11-1-89</i>	

File Copy

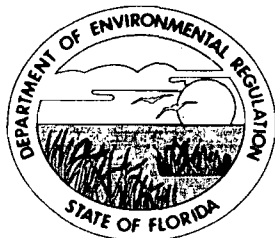

# Florida Department of Environmental Regulation

Twin Towers Office Bldg. • 2600 Blair Stone Road • Tallahassee, Florida 32399-2400

Bob Martinez, Governor

Dale Twachtmann, Secretary

John Shearer, Assistant Secretary

October 27, 1989

CERTIFIED MAIL - RETURN RECEIPT REQUESTED

Mr. Lawrence R. Hutker  
Director, Facilities Department  
Harris Semiconductor  
Post Office Box 883  
Melbourne, Florida 32901

Dear Mr. Hutker:

Re: Fume Scrubber Replacement - Building 51  
AC 05-157786

The Department has reviewed Ms. Nancy Baldisserotto's letter received October 10, 1989, explaining the need to replace a fume scrubber (F51S05) with an existing fume scrubber (to be designated F51S05). The Department finds the request acceptable. However, if the efficiency of the existing replacement fume scrubber has never been determined, then tests should be conducted for this at your earliest possible date; also, the Central District office is to be notified in writing 15 days prior to conducting tests.

If there are any questions, please call Bruce Mitchell at (904)488-1344 or write to me at the above address.

Sincerely,

C. H. Fancy, P.E.  
Bureau of Air Regulation

CHF/BM/t

attachment

cc: C. Collins, Central District  
N. Baldisserotto, HS

Reading File }  
Bruce Mitchell } 11-1-89 RM

F.10 C.902

PM  
10-10-89  
Melbourne, FL



RECEIVED  
OCT 10 1989  
DER-BAQM

October 6, 1989

Mr. Claire Fancy  
Deputy Chief  
Bureau of Air Quality Management  
Florida Department of  
Environmental Regulation  
Twin Towers Office Building  
2600 Blair Stone Road  
Tallahassee, FL 32399-2400

Re: Exhaust system modification; Permit No. AC 05-157786  
Building 51 Consolidated Air Permit

Dear Mr. Fancy:

By this letter, we are providing the Department with notice that it is necessary to reactivate an existing water scrubber system to treat solvent exhaust currently handled by scrubber number F51S05. The current system has been experiencing a water carry-over problem that the manufacturers' representatives and our engineers have been unable to resolve.

The replacement scrubber system is an IPF model 153-350, 35,000 cfm horizontal cross-flow fume scrubber (see attachments). The scrubber is located in the west corner of the building 51 penthouse (see scrubber location map). It is estimated that the scrubber will be ready for use by November 1. It will be assigned the same facilities identification number F51S05 as the current system. Since this system has a greater capacity than the current system, it should function, at least, as well and perhaps better.

If the Department has no objection, we will proceed to close down the current system and activate this system in early November. If you have any questions, please give me a call at (407)729-4061.

Sincerely,

Nancy Baldisserotto  
Environmental Engineer  
Harris Semiconductor

E/303/89

Attachments

 Worldwide Courier and Cargo		<b>SERVICES</b> UNITED STATES / CANADA Same Day <input type="checkbox"/> Next Morning <input checked="" type="checkbox"/> Second Day <input type="checkbox"/>		INTERNATIONAL Courier Express <input type="checkbox"/> Air Cargo <input type="checkbox"/> Air Economy <input type="checkbox"/>		Business Documents <input type="checkbox"/> Customs Clearance <input type="checkbox"/> Delivery <input type="checkbox"/>	
CASH <input type="checkbox"/> GBL <input type="checkbox"/> CBL <input type="checkbox"/> PPD <input checked="" type="checkbox"/> COL <input type="checkbox"/> OTH <input type="checkbox"/> COMAT <input type="checkbox"/>		FCCOD <input type="checkbox"/>		Date: 4/8/89 Origin: ORL Shipment Number: 223568038 1			
Shipper's Account Number <b>E 539427716</b>		From: <i>Home address # 734-4001</i>		To: <i>Melrose Farm</i>		Tariff Dest. Gateway	
HARRIS SEMICONDUCTOR		PALM BAY ROAD		PALM BAY FL		Check to Shipper: \$ Hold for Pick Up <input type="checkbox"/> Canada <input type="checkbox"/>	
Customer's Reference Numbers		Zip: 32908		Consignee's Account Number: <b>E</b>		Zip: 32992	
Description		Dimensions: Pos. L W H		Total Pieces: 11		Total Weight (in Lbs): 11	
TODSR <input type="checkbox"/> Haz Mat <input type="checkbox"/> Edit <input type="checkbox"/>		A B C D E F G H I J K		1 2 3 4 5 6 7 8 9 0 1 2		Envelope <input checked="" type="checkbox"/> Pack <input checked="" type="checkbox"/> 9X12 <input checked="" type="checkbox"/> 12X15 <input checked="" type="checkbox"/>	
Shipper's Signature: <i>[Signature]</i>		International Shipments		Third Party Account Number: <b>E</b>		Commodity Code	
Free Domicile <input type="checkbox"/>		International Customs Value		International Insurance		Declared Value: \$	
Base Charge		Total Transportation Charges		Other Charges/Advance at Origin: CC/AO- \$		FOR INFORMATION OR RATES CALL 1-800 HI EMERY	

260

Terms and Conditions on Back



HARRIS SEMICONDUCTOR  
SCRUBBER LOCATIONS  
BUILDING 51

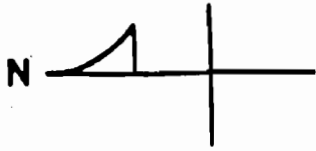

LEGEND

	- Horizontal Scrubber
	- Vertical Scrubber
	- Exhaust Stack
	- Exhaust Fan
	- Stack mounted on fan
	- Epitaxial Scrubber

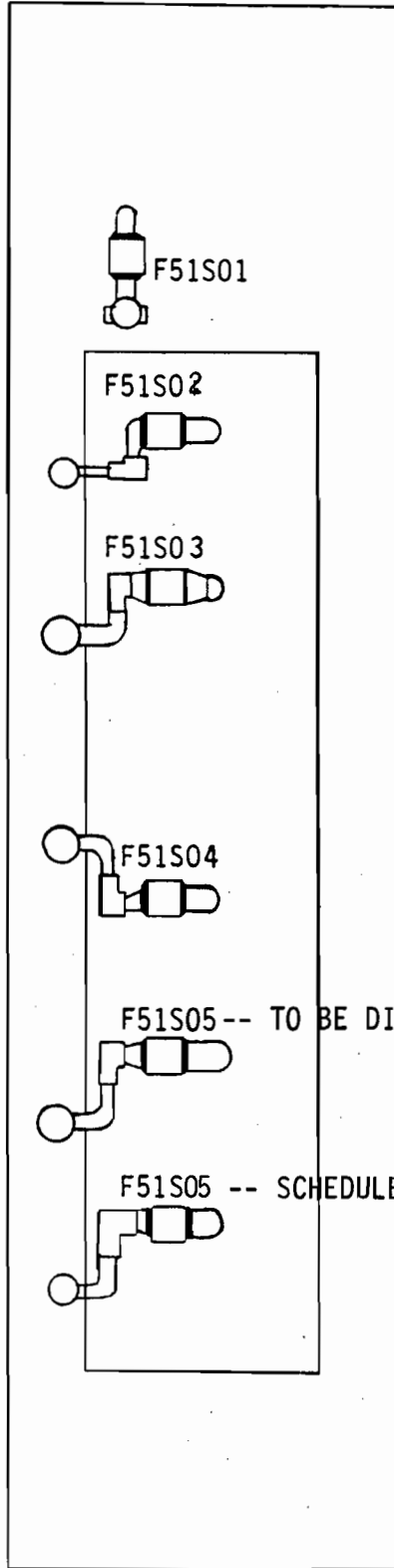

F51S05 -- TO BE DISCONTINUED

F51S05 -- SCHEDULED TO BE IN USE 11/01/89

FS-1 DATA SHEET

Submitted by Industrial Plastic Fabricators, Inc.

April 15, 1975

Complete this data sheet and submit with proposal.

1. Manufacturer	<u>Industrial Plastic Fabricators, Inc.</u>
2. Model no.	<u><del>151-350</del> 153-350</u>
3. Capacity, cfm	<u>35,000</u>
4. Casing material	<u>PVC Backed with Fiberglass</u>
5. Casing thickness	<u>1/8" PVC/3/8" FRP</u>
<del>6. Motor nameplate horsepower</del>	<u>2 H.P.</u>
<del>7. Bhp at operating conditions</del>	<u>1.7</u>
8. Pump capacity, gpm	<u>36 GPM @ 30 FT. HD</u>
9. Pump manufacturer	<u>Vanton</u>
10. Pump material	<u>Polypropylene</u>
11. Size and number of access doors	<u>16" Diameter - 6</u>
12. Type of fill	<u>2" Polypro Tellerettes</u>
13. Pressure drop at rated conditions, inches wg	<u>1 1/2" Maximum</u>
14. Amount of moisture carryover	<u>.05% Maximum - see high offray</u>
15. Estimated delivery from time of order, weeks	<u>10-12 Weeks</u>

 **Industrial Plastic Fabricators**  
ENDICOTT STREET NORWOOD, MASSACHUSETTS  
Telephone: 782-3111



FS-1 DATA SHEET

Submitted by Industrial Plastic Fabricators, Inc. April 15, 1975

Complete this data sheet and submit with proposal.

1. Manufacturer	<u>Industrial Plastic Fabricators, Inc.</u>
2. Model no.	<u><del>151-350</del> 153-350</u>
3. Capacity, cfm	<u>35,000</u>
4. Casing material	<u>PVC Backed with Fiberglass</u>
5. Casing thickness	<u>1/8" PVC/3/8" FRP</u>
<del>6. Motor nameplate horsepower</del>	<u>2 H.P.</u>
<del>7. Bhp at operating conditions</del>	<u>1.7</u>
8. Pump capacity, gpm	<u>36 GPM @ 30 FT. HD</u>
9. Pump manufacturer	<u>Vanton</u>
10. Pump material	<u>Polypropylene</u>
11. Size and number of access doors	<u>16" Diameter - 6</u>
12. Type of fill	<u>2" Polypro Tellerettes</u>
13. Pressure drop at rated conditions, inches wg	<u>1 1/2" Maximum</u>
14. Amount of moisture carryover	<u>.05% Maximum - see high off.</u>
15. Estimated delivery from time of order, weeks	<u>10-12 Weeks</u>

**ipf** Industrial Plastic Fabricators  
 ENDICOTT STREET NORWOOD, MASSACHUSETTS  
 Telephone: 782-3111



CORROSIVE RESISTANT  
**Fume Scrubbers**

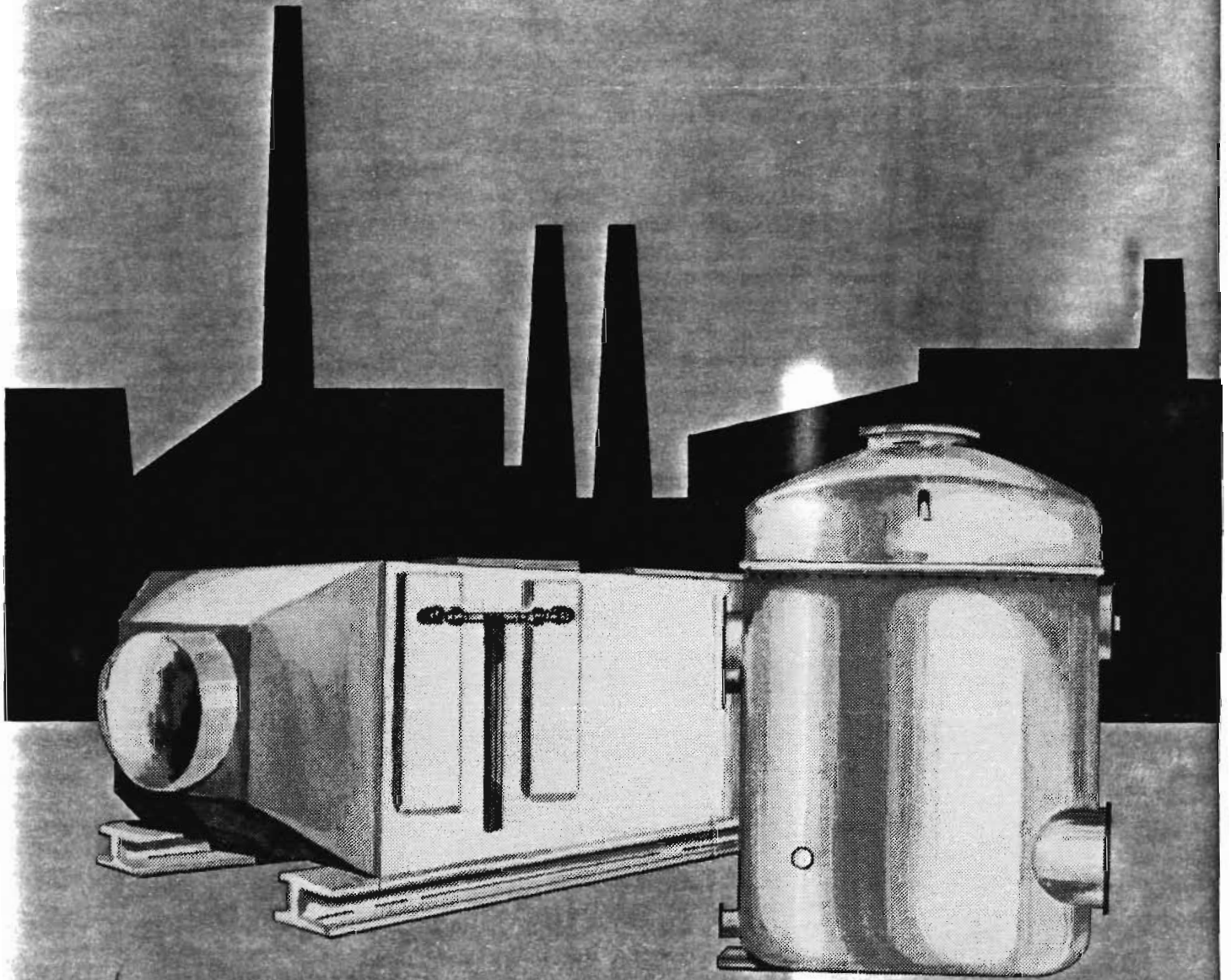

P.O. BOX 253, 290 PINE STREET • CANTON, MASSACHUSETTS 02021



## IPF Scrubbers

IPF offers a complete package of services and equipment to assist in solving air pollution problems. They will take a step-by-step analysis of a particular problem and develop the correct solution. IPF will seek out the most cost effective method while prescribing the right equipment to do the job properly.

### CONSULTING SERVICES

IPF engineers are available to advise each customer. They will work on location on a customer's particular air pollution problem. They will recommend the correct scrubber to meet the existing conditions or, if the need exists, design a complete ventilating system.

### SCRUBBER EQUIPMENT

**Efficiency**—IPF scrubbers can be designed to remove up to 99.999% of airborne corrosives. Since each system is designed for a specific need, a high degree of efficiency can be designed into each unit, regardless of particle size.

**99.999%**

**Packing Material**—in any scrubbing system the packing material is the most important factor in the efficient operation of the equipment. IPF puts its own Compu-Pak packing material into each unit. Compu-Pak is a computer designed packing material, which is specially made for each application to entrap particles of various sizes and weights. Compu-Pak packing is made in various micron thicknesses with a patented interlocking weave to allow for maximum scrubbing efficiency. Thickness will depend upon desired efficiency, gas velocity, gas composition, droplet size, and particle construction.

**Construction**—each scrubber is made with corrosive resistant materials. Fibreglas, Type G PVC, or Type G polypropylene which are all inherently corrosive resistant are used in the construction of IPF units.

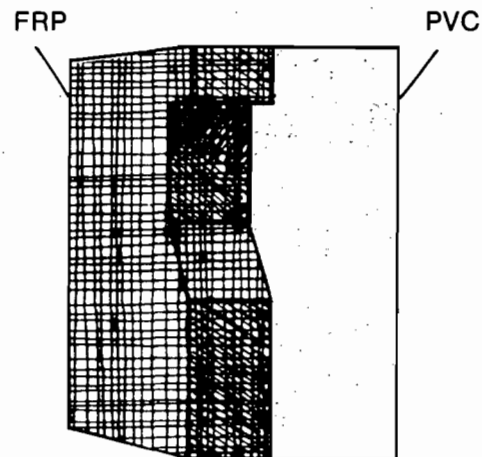
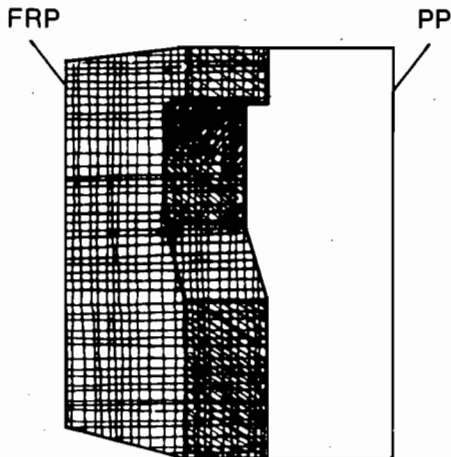



## Horizontal Scrubbers

In an IPF horizontal scrubber the airflow containing corrosive particles enters the scrubbing unit and is immediately expanded to allow for equal distribution of the flow. The air is heavily sprayed with liquids as it passes into the first layer of packing and as it passes through the packing material. While passing through the packing, the corrosive particles are drawn to the packing through impingement and then flushed down into the sump area to be washed away. The clean airflow is then sprayed with additional liquids, in the form of a mist, to eliminate any particles which might still be present. It then goes into the mist eliminator which removes the moisture in the airflow.

The packing material is designed to provide excellent break-up of the liquid phase, creating maximum surface area for mass transfer with the vapor phase.

Horizontal scrubbers are recommended for use in situations where space limitations may be a problem.

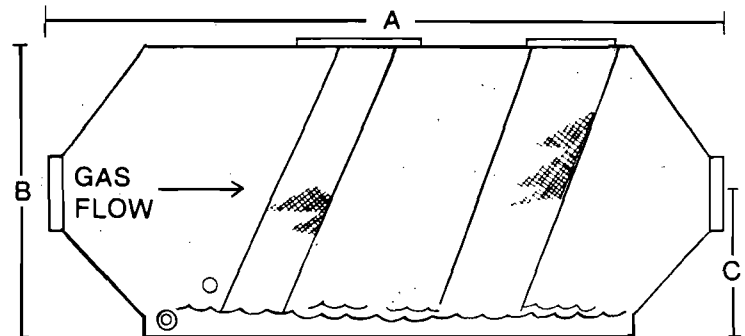

### Horizontal

MODEL	CFM CAPACITY	LIQUID RATE GPM	*1 TOTAL LENGTH A	*2 HEIGHT WITH SUMP B	WIDTH	BASE TO CL. INLET & OUTLET C	I.D. INLET & OUTLET	SHIPPING WEIGHT	OPERATING WEIGHT
H153-5	500	3-6	4'0"	2'3"	2.0	19½"	8"	160	530
H153-10	1,000	2-10	4'0"	2'3"	2.0	19½"	8"	160	530
H153-20	2,000	4-16	4'0"	3'6"	2.0	27"	12"	250	620
H153-40	4,000	8-32	7'0"	5'	3.0	36"	16"	900	2200
H153-50	5,000	10-40	7'0"	5'	3.6	36"	18"	1050	2600
H153-75	7,500	15-60	7'4"	5'	4.0	36"	22"	1200	3000
H153-100	10,000	20-80	7'4"	6'	4.6	42"	25"	1500	3600
H153-125	12,500	25-100	7'4"	7'	5.0	48"	25"	2000	4200
H153-150	15,000	30-120	8'0"	7'	5.6	48"	28"	2400	5100
H153-175	17,500	35-140	8'0"	8'	5.6	54"	28"	2700	5500
H153-200	20,000	40-160	9'0"	8'	6.0	54"	32"	3100	6400
H153-250	25,000	50-200	9'0"	8'	7.0	54"	36"	3500	7400
H153-300	30,000	60-240	10'0"	8'	8.0	54"	42"	4000	9000
H153-400	40,000	80-320	10'0"	10'	8.0	66"	48"	4680	9680

\*1 Varies with the amount of packing.

\*2 Deduct 10" if no sump required.

Static pressure drop is 0.41" per each 4 layers of packing at 96% efficiency.

All dimensions are approximate.

Make-up water is approximately 10% of GPM.



ri  
5.2  
Melbourne, FL

RECEIVE

MAY 4 1989

DER-BAQM

all fills)

April 27, 1989

Mr. Bruce Mitchell  
Engineer  
Bureau of Air Quality Management  
Florida Department of Environmental Regulation  
Twin Towers Office Building  
2600 Blair Stone Road  
Tallahassee, FL 32399-2400

Subject: Consolidated air permits -- Harris Semiconductor

Dear Mr. Mitchell:

The purpose of this memo is to summarize the clarifications made during our phone conversation on April 27, 1989. The questions raised were in regard to the appropriate submittal dates for stack monitoring data, site mass balance information, and operating permit applications for each building. The following conclusions were reached:

1. Stack monitoring data will be submitted to the department within 45 days after the last test run is completed.
2. Operating permit applications will be submitted at least 90 days prior to the expiration date of the construction permits. These applications are to include the site's material balance results, by building. If additional time is needed to compile these applications, Semiconductor will request an extension.

If there are any discrepancies, please contact me at (407) 729-4061.

Sincerely,

*Nancy Baldisserotto*

Nancy Baldisserotto  
Environmental Engineer  
Harris Semiconductor Corporation

*copied: C. Collins, CF Dist  
B. Mitchell  
CHF/BT*

CAPE PUBLICATIONS, INC.

The Times

Published Weekly on Wednesday

THE TRIBUNE

Published Weekly on Wednesday

RECEIVED

MAR 10 1989



Published Daily

DER-BAQM

STATE OF FLORIDA
COUNTY OF BREVARD

Before the undersigned authority personally appeared Linda L. Spicer who on oath says that he/she is Legal Advertising Clerk of the FLORIDA TODAY, a newspaper published in Brevard County,

Florida; that the attached copy of advertising being a Legal Notice in the matter of permit to Harris Semiconductor in the Court

was published in the FLORIDA TODAY NEWSPAPER in the issues of March 4, 1989

Affiant further says that the said FLORIDA TODAY NEWSPAPER is a newspaper published in said Brevard County, Florida and that the said newspaper has heretofore been continuously published in said Brevard County, Florida regularly as stated above, and has been entered as second class mail matter at the post office in COCOA, said Brevard County, Florida for a period of one year next preceeding the first publication of the attached copy of advertisement; and affiant further says that he has neither paid nor promised any person, firm or corporation any discount, rebate, commission or refund for the purpose of securing this advertisement for publication in said newspaper.

Sworn and subscribed to before me this 4th day of March, 1989. Linda L. Spicer (signature) Cathy (signature) Notary Public

Notary Public
State of Florida at Large
My Commission Expires March 29, 1992

State of Florida
Department of
Environmental Regulation
Notice of Intent to Issue
The Department of Environmental Regulation hereby gives notice of its intent to issue permits to Harris Semiconductor, Post Office Box 883, Melbourne, Florida 32901, to consolidate multiple permits previously issued for Buildings No. 51, 42, 63 and 58, which are sources involved with the fabrication and testing of integrated circuits. The proposed project will occur at the applicant's existing facility in Brevard County, Florida. The Department is issuing this intent to issue for the reasons stated in the Technical Evaluation and Preliminary Determination.
A person whose substantial interests are affected by the department's proposed permitting decision may petition for an administrative proceeding (hearing) in accordance with Section 120.57, Florida Statutes. The petition must contain the information set forth below and must be filed (received) in the Office of General Counsel of the Department at 2600 Blair Stone Road, Tallahassee, Florida 32399-2400, within fourteen (14) days of publication of this notice. Petitioner shall mail a copy of the petition to the applicant at the address indicated above at the time of filing. Failure to file a petition within this time period shall constitute a waiver of any right such person may have to request an administrative determination (hearing) pursuant to Section 120.57, Florida Statutes.
The petition shall contain the following information:
(a) The name, address, and telephone number of each petitioner, the applicant's name and address, the Department Permit File Number and the county in which the project is proposed;
(b) A statement of how and when each petitioner received notice of the Department's action or proposed action;
(c) A statement of how each petitioner's substantial interests are affected by the Department's action or proposed action;
(d) A statement of the material facts disputed by Petitioner, if any;
(e) A statement of facts which petitioner contends warrant reversal or modification of the Department's action or proposed action;
(f) A statement of which rules or statutes petitioner contends require reversal or modification of the Department's action or proposed action; and,
(g) A statement of the relief sought by petitioner, stating precisely the action petitioner wants the Department to take with respect to the Department's action or proposed action.
If a petition is filed, the administrative hearing process is designed to formulate agency action. Accordingly, the Department's final action may be different from the position taken by it in this Notice. Persons whose substantial interests will be affected by any decision of the Department with regard to the applications have the right to petition to become a party to the proceeding. The petition must conform to the requirements specified above and be filed (received) within 14 days of publication of this notice in the Office of General Counsel at the above address of the Department. Failure to petition within the allowed time frame constitutes a waiver of any right such person has to request a hearing under Section 120.57, F.S., and to participate as a party to this proceeding. Any subsequent intervention will only be at the approval of the presiding officer upon motion filed pursuant to Rule 28-5.207, F.A.C.
The applications are available for public inspection during normal business hours, 8:00 a.m. to 5:00 p.m., Monday through Friday except legal holidays, at:
Dept. of Environmental Regulation
Bureau of Air Quality Management
2600 Blair Stone Road
Tallahassee, Florida 32399-2400
Dept. of Environmental Regulation
Central Florida District
3319 Maguire Blvd., Suite 232
Orlando, Florida 32803-3767
Any person may send written comments on the proposed action to Mr. Bill Thomas at the Department's Tallahassee address. All comments mailed within 14 days of the publication of this notice will be considered in the Department's final determination.
T0099284-1T-3/4, 1989, Saturday





FLORIDA TODAY/USA TODAY  
 GANNETT PLAZA  
 P.O. BOX 363000  
 MELBOURNE, FL 32936

RECEIVED

MAR 10 1989

DER-BAQM



STATE OF FLORIDA  
 DEPARTMENT OF ENVIRONMENTAL REGULATION  
 TWIN TOWERS OFFICE BUILDING  
 2600 BLAIR STONE ROAD  
 TALLAHASSEE, FLORIDA 32301-8241

ATTN: C.H. FANCY, P.E.  
 BUREAU OF AIR QUALITY MGNT.

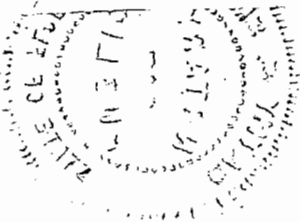
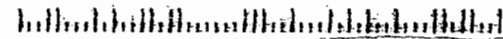

*Pulsator 462658786  
2-28-89  
Palm Bay, FL*

*file copy*



FS-JRK-123-89

C. H. Fancy, P.E.  
Deputy Chief  
Bureau of Air Quality Management  
Twin Towers Office Building  
2600 Blair Stone Road  
Tallahassee, Florida 32399

RECEIVED

MAR 1 1989

DER-BAQM

**SUBJECT: TECHNICAL EVALUATION AND PRELIMINARY DETERMINATION  
AIR PERMIT FOR BUILDING 51, 62, 63, AND 58**

Dear Mr. Fancy:

We are in receipt of the subject Technical Evaluation and Preliminary Determination, which was received February 13, 1989. We have proceeded with publication of the required notice.

We would like to make the following comments on the subject matter.

Item 1      Technical Evaluation item C.2. second paragraph reads,  
"However, because this area is used as a production area, the wet  
stations..."

This sentence should read, "However, because this area is not used  
as a production area, the wet stations..."

Item 2      Permit AC05-157786, AC05-157787, AC05-158237, and AC05-159484, under  
Specific Conditions 7.a) refers to EPA reference Method 25, the  
correct EPA reference method is Methods 25A.

Item 3      Monitoring frequency - Harris has been classifying its VOC/solvent  
emissions sources into three categories:  
1. significant  
2. moderate  
3. minor

Of the VOC/solvent emission sources covered by the subject  
consolidated permit applications, they fall into the following  
corresponding categories:

<u>Significant</u>	<u>Moderate</u>	<u>Minor</u>
F51S02 - solvent	F58S01 - combined	F58S02 - solvent
F51S03 - combined	F62S02 - acid	
F51S04 - combined	F63S03 - solvent	
F51S05 - solvent		
F63S02 - solvent		

FS-JRK-123-89  
2/28/89, p. 2

These classifications are based on type of manufacturing facility and potential emissions. Harris Semiconductor is requesting that emission monitoring of the air emissions be on the following frequencies.

1. Significant - annual
2. Moderate - three year cycle
3. Minor - five year cycle.

We recommend that only the actual emissions of VOC sources be monitored. This is due primarily to the fact that several of our exhaust systems are configured in such a manner that inlet samples to the scrubbers cannot be collected in such a manner as to assure the accuracy of the data collection.

If you should have any questions about the above comments, please contact me at (407) 724-7467.

Sincerely,



J. R. Kolanek, Manager  
Environmental Services

/pgc

cc: N. A. Baldisserotto  
D. R. Erdley  
L. R. Hutker  
R. R. Sands  
J. R. Steiner

*copied: B. Mitchell  
C. Collins, CF Dist.  
CHF/BT*

P 274 007 576

RECEIPT FOR CERTIFIED MAIL

NO INSURANCE COVERAGE PROVIDED  
NOT FOR INTERNATIONAL MAIL  
(See Reverse)

PS Form 3800, June 1985 \* U.S.G.P.O. 1985-480-794

Sent to <b>Mr. J. R. Kolanek, Harris</b>	
Street and No. <b>Semiconductor</b>	
<b>P.O. Box 883</b>	
P.O., State and ZIP Code <b>Melbourne, FL 32901</b>	
Postage	S
Certified Fee	
Special Delivery Fee	
Restricted Delivery Fee	
Return Receipt showing to whom and Date Delivered	
Return Receipt showing to whom, Date, and Address of Delivery	
TOTAL Postage and Fees	S
Postmark or Date  Mailed: 2-10-89 Permit: AC 05-157786 -159484, -157787, -158237	

**SENDER:** Complete items 1 and 2 when additional services are desired, and complete items 3 and 4. Put your address in the "RETURN TO" Space on the reverse side. Failure to do this will prevent this card from being returned to you. The return receipt fee will provide you the name of the person delivered to and the date of delivery. For additional fees the following services are available. Consult postmaster for fees and check box(es) for additional service(s) requested.

1.  Show to whom delivered, date, and addressee's address. (Extra charge) 2.  Restricted Delivery (Extra charge)

3. Article Addressed to: <b>Mr. J. R. Kolanek Manager, Environmental Services Harris Semiconductor P. O. Box 883 Melbourne, Florida 32901</b>	4. Article Number <b>P 274 007 576</b>
5. Signature - Address <b>X</b>	Type of Service: <input type="checkbox"/> Registered <input type="checkbox"/> Insured <input checked="" type="checkbox"/> Certified <input type="checkbox"/> COD <input type="checkbox"/> Express Mail <input type="checkbox"/> Return Receipt for Merchandise
6. Signature - Agent <b>X Willie Harris Semiconductor</b>	Always obtain signature of addressee or agent and DATE DELIVERED.
7. Date of Delivery <b>2-3-89</b>	8. Addressee's Address (ONLY if requested and fee paid)

Main File Copy

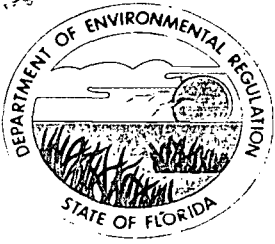

## Florida Department of Environmental Regulation

Twin Towers Office Bldg. • 2600 Blair Stone Road • Tallahassee, Florida 32399-2400

Bob Martinez, Governor

Dale Twachtmann, Secretary

John Shearer, Assistant Secretary

February 7, 1989

CERTIFIED MAIL-RETURN RECEIPT REQUESTED

Mr. James R. Kolanek  
Manager, Environmental Services  
Harris Semiconductor  
Post Office Box 883  
Melbourne, Florida 32901

Dear Mr. Kolanek:

Attached is one copy of the Technical Evaluation and Preliminary Determination and proposed permits for Harris Semiconductor to consolidate multiple permits previously issued for Buildings No. 51, 62, 63 and 58, which are sources involved with the fabrication and testing of integrated circuits.

Please submit any written comments you wish to have considered concerning the Department's proposed action to Mr. Bill Thomas of the Bureau of Air Quality Management.

Sincerely,

C. H. Fancy, P.E.  
Deputy Chief  
Bureau of Air Quality  
Management

CHF/bm

Attachments

cc: C. Collins, Cent. Fl Dist.  
L. R. Hutker, P.E., HS

Bruce Mitchell } 2-10-89 PM  
Ready File

BEFORE THE STATE OF FLORIDA  
DEPARTMENT OF ENVIRONMENTAL REGULATION

In the Matter of  
Applications for Permits by:

Harris Semiconductor  
Post Office Box 883  
Melbourne, Florida 32901

DER File Nos. AC 05-157786  
AC 05-517787  
AC 05-158237  
AC 05-159484

---

INTENT TO ISSUE

The Department of Environmental Regulation hereby gives notice of its intent to issue permits (copies attached) for the proposed project as detailed in the applications specified above. The Department is issuing this Intent to Issue for the reasons stated in the attached Technical Evaluation and Preliminary Determination.

The applicant, Harris Semiconductor, applied on November 28, 1988, December 9, 1988, and January 17, 1989, to the Department of Environmental Regulation for permits to consolidate multiple permits previously issued for Buildings No. 51, 62, 63 and 58, which are sources involved with the fabrication and testing of integrated circuits. The proposed project will occur at the applicant's existing facility located in Melbourne, Brevard County, Florida.

The Department has permitting jurisdiction under Chapter 403, Florida Statutes (F.S.), and Florida Administrative Code (F.A.C.) Rules 17-2 and 17-4. The project is not exempt from permitting procedures. The Department has determined that air construction permits were needed for the proposed work.

Pursuant to Section 403.815, F.S., and DER Rule 17-103.150, F.A.C., you (the applicant) are required to publish at your own expense the enclosed Notice of Intent to Issue Permits. The notice must be published one time only within 30 days, in the legal ad section of a newspaper of general circulation in the area affected. For the purpose of this rule, "publication in a newspaper of general circulation in the area affected" means publication in a newspaper meeting the requirements of Sections 50.011 and 50.031, F.S., in the county where the activity is to take place. The applicant shall provide proof of publication to the Department, at the address specified, within seven days of publication. Failure to publish the notice and provide proof of publication within the allotted time may result in the denial of the permits.

The Department will issue the permits with the attached conditions unless a petition for an administrative proceeding (hearing) is filed pursuant to the provisions of Section 120.57, F.S.

A person whose substantial interests are affected by the Department's proposed permitting decision may petition for an administrative proceeding (hearing) in accordance with Section 120.57, Florida Statutes. The petition must contain the information set forth below and must be filed (received) in the Office of General Counsel of the Department at 2600 Blair Stone Road, Tallahassee, Florida 32399-2400. Petitions filed by the permit applicant and the parties listed below must be filed within 14 days of receipt of this intent. Petitions filed by other persons must be filed within 14 days of publication of the notice or within 14 days of receipt of this intent, whichever occurs first. Petitioner shall mail a copy of the petition to the applicant at the address indicated above at the time of filing. Failure to file a petition within this time period shall constitute a waiver of any right such person may have to request an administrative determination (hearing) under Section 120.57, Florida Statutes.

The Petition shall contain the following information:

(a) The name, address, and telephone number of each petitioner, the applicant's name and address, the Department Permit File Number and the county in which the project is proposed;

(b) A statement of how and when each petitioner received notice of the Department's action or proposed action;

(c) A statement of how each petitioner's substantial interests are affected by the Department's action or proposed action;

(d) A statement of the material facts disputed by petitioner, if any;

(e) A statement of facts which petitioner contends warrant reversal or modification of the Department's action or proposed action;

(f) A statement of which rules or statutes petitioner contends require reversal or modification of the Department's action or proposed action; and,

(g) A statement of the relief sought by petitioner, stating precisely the action petitioner wants the Department to take with respect to the Department's action or proposed action.

If a petition is filed, the administrative hearing process is designed to formulate agency action. Accordingly, the Department's final action may be different from the position taken by it in this Notice. Persons whose substantial interests will be affected by any decision of the Department with regard to the applicant have the right to petition to become a party to the proceeding. The petition must conform to the requirements specified above and be filed (received) within 14 days of publication of this notice in the Office of General Counsel at the above address of the Department. Failure to petition within the allowed time frame constitutes a waiver of any right such

person has to request a hearing under Section 120.57, F.S., and to participate as a party to this proceeding. Any subsequent intervention will only be at the approval of the presiding officer upon motion filed pursuant to Rule 28-5.207, F.A.C.  
Executed in Tallahassee, Florida.

STATE OF FLORIDA DEPARTMENT  
OF ENVIRONMENTAL REGULATION

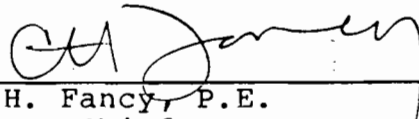

---

C. H. Fancy, P.E.  
Deputy Chief  
Bureau of Air Quality  
Management

Copies furnished to:

C. Collins, Cent. FL Dist.  
L. R. Hutker, P.E., HS



CERTIFICATE OF SERVICE

The undersigned duly designated deputy clerk hereby certifies that this NOTICE OF INTENT TO ISSUE and all copies were mailed before the close of business on 2-10-89.

FILING AND ACKNOWLEDGEMENT  
FILED, on this date, pursuant to  
§120.52(9), Florida Statutes, with  
the designated Department Clerk,  
receipt of which is hereby  
acknowledged.

Martha Wise  
Clerk

2-10-89  
Date

State of Florida  
Department of Environmental Regulation  
Notice of Intent to Issue

The Department of Environmental Regulation hereby gives notice of its intent to issue permits to Harris Semiconductor, Post Office Box 883, Melbourne, Florida 32901, to consolidate multiple permits previously issued for Buildings No. 51, 62, 63 and 58, which are sources involved with the fabrication and testing of integrated circuits. The proposed project will occur at the applicant's existing facility in Brevard County, Florida. The Department is issuing this Intent to Issue for the reasons stated in the Technical Evaluation and Preliminary Determination.

A person whose substantial interests are affected by the Department's proposed permitting decision may petition for an administrative proceeding (hearing) in accordance with Section 120.57, Florida Statutes. The petition must contain the information set below and must be filed (received) in the Office of General Counsel of the Department at 2600 Blair Stone Road, Tallahassee, Florida 32399-2400, within fourteen (14) days of publication of this notice. Petitioner shall mail a copy of the petition to the applicant at the address indicated above at the time of filing. Failure to file a petition within this time period shall constitute a waiver of any right such person may have to request an administrative determination (hearing) under Section 120.57, Florida Statutes.

The Petition shall contain the following information:

- (a) The name, address, and telephone number of each petitioner, the applicant's name and address, the Department Permit File Number and the county in which the project is proposed;
- (b) A statement of how and when each petitioner received notice of the Department's action or proposed action;
- (c) A statement of how each petitioner's substantial interests are affected by the Department's action or proposed action;
- (d) A statement of the material facts disputed by petitioner, if any;
- (e) A statement of facts which petitioner contends warrant reversal or modification of the Department's action or proposed action;
- (f) A statement of which rules or statutes petitioner contends require reversal or modification of the Department's action or proposed action; and,
- (g) A statement of the relief sought by petitioner, stating precisely the action petitioner wants the Department to take with respect to the Department's action or proposed action.

If a petition is filed, the administrative hearing process

is designed to formulate agency action. Accordingly, the Department's final action may be different from the position taken by it in this Notice. Persons whose substantial interests will be affected by any decision of the Department with regard to the applications have the right to petition to become a party to the proceeding. The petition must conform to the requirements specified above and be filed (received) within 14 days of publication of this notice in the Office of General Counsel at the above address of the Department. Failure to petition within the allowed time frame constitutes a waiver of any right such person has to request a hearing under Section 120.57, F.S., and to participate as a party to this proceeding. Any subsequent intervention will only be at the approval of the presiding officer upon motion filed pursuant to Rule 28-5.207, F.A.C.

The applications are available for public inspection during normal business hours, 8:00 a.m. to 5:00 p.m., Monday through Friday, except legal holidays, at:

Dept. of Environmental Regulation  
Bureau of Air Quality Management  
2600 Blair Stone Road  
Tallahassee, Florida 32399-2400

Dept. of Environmental Regulation  
Central Florida District  
3319 Maguire Blvd., Suite 232  
Orlando, Florida 32803-3767

Any person may send written comments on the proposed action to Mr. Bill Thomas at the Department's Tallahassee address. All comments mailed within 14 days of the publication of this notice will be considered in the Department's final determination.

Technical Evaluation  
and  
Preliminary Determination

Harris Semiconductor  
Brevard County  
Palm Bay, Florida

Construction Permit Numbers:

AC 05-157786

AC 05-157787

AC 05-158237

AC 05-159484

Florida Department of Environmental Regulation  
Division of Air Resources Management  
Bureau of Air Quality Management  
Central Air Permitting

February 7, 1989

## I. Application

### A. Applicant

Harris Semiconductor  
Post Office Box 883  
Melbourne, Florida 32901

### B. Project and Location

The applicant has applied for construction permits for Buildings Nos. 51, 62, 63 and 58, in order to consolidate multiple permits previously issued for these sources/buildings.

The existing facility is located on Palm Bay Road, City of Palm Bay, Florida. The UTM coordinates are Zone 17, 538.7 km East and 3100.9 km North.

### C. Process and Controls

#### 1. Building 51

Building 51 is a wafer fabrication facility. The second floor of the two-story building houses two clean room modules. Both fabrication areas employ a series of manufacturing procedures referred to as layering, patterning, doping and heating processes. The frequency and sequence of these processes can vary depending on the desired nature of the final product.

Wet stations that house vats containing a variety of acid and caustic compounds are located throughout the clean rooms. Building 51 utilizes approximately 50 stations, one-third of which contain vats of solvent-based chemicals. Less than one-fourth of the stations are heated. Presently, stainless steel covers are being fabricated for all of the vats containing solvents. Gas cabinets, vacuum pumps, and chemical drains are located in areas dedicated to the containment of vented units. Storage cabinets safely hold virgin chemicals until they are ready for use.

The exhaust system for the building is divided amongst five scrubbers. The scrubbers numbered F51S01, F51S02, and F51S03 serve the east module, while F51S04 and F51S05 serve the west module. Scrubber F51S01 is an acid control system. Scrubbers F51S02 and F51S05 are solvent control systems. Scrubbers F51S03 and F51S04 are both acid and solvent control systems.

#### 2. Building 62

Building 62 is comprised of two units: building A and building B. Building B's activities do not involve air

pollution. The first floor of building A contains Semiconductor's research and development lab, and an analytical services laboratory, while a technical and prototype assembly lab resides on the second floor of the two-story building.

In the research and development laboratory, wafer fabrication processes (layering, patterning, doping and heating) are simulated. The goal of the lab is to develop new film processes for use in the on-site production of semiconductor wafers. These new operations may require new chemicals and equipment, as well as experimental wet chemistry techniques. The area resembles a small wafer fabrication area, with a variety of fab equipment being present. However, because this area is used as a production area, the wet stations, coaters, developers, etchers, aligners, sputtering systems, deposition furnaces, and associated burn boxes and pumps are present in low numbers.

The analytical services laboratory is responsible for physical and chemical characterization of microelectronic materials and products. A wide variety of analysis techniques are employed, including spectroscopy, separation methods, thermal analysis, and wet chemistry. The vented wet stations provide a safe location for analytical procedures involving wet chemistry.

For both of the above mentioned areas, gas cylinders that provide necessary process gases to the lab equipment are contained in vented gas cabinets located in the chases behind the appropriate area of use. Chemical storage cabinets hold virgin chemicals until they are ready for use.

In the technical lab on the second floor, electronic testing of new products (circuits that have not yet been released to the customer) and prototype assembly of circuits occur. A relatively small number of equipment requiring venting exists in this area.

There are 19 wet stations located in the building. Approximately half of these stations house vats containing solvents. There are presently five stations containing heated vats; of these, four are acid stations and one is a solvent station.

The exhaust for the building is divided between two scrubber control systems. Acid vapors are vented to scrubber F62S01, while solvent exhaust streams are ducted to scrubber F62S02. Both control systems reside on the site grounds directly outside the south wall of building A.

### 3. Building 63

The primary processes occurring in building 63 are wafer fabrication and assembly. Because the processes and equipment

utilized in the two areas are, for the most part, dissimilar, the two areas are described separately.

The wafer fabrication area employs a series of manufacturing procedures referred to as layering, patterning, doping and heating. The frequency and sequence of these processes can vary depending on the desired nature of the final product.

In the controlled environment of the fabrication clean room, wafer surfaces first undergo acid and/or solvent cleaning, followed by thermal oxidation in furnaces to form a layer of silicon dioxide on the wafer surface.

During the patterning process, the wafers are initially baked and primed. Coaters then spin a thin layer of "photoresist" on the wafer, after which the wafers are soft baked. Next, the circuit pattern is projected onto the wafers via "aligners" or "steppers." Developers are then applied to remove unpolymerized areas of photoresist. This is followed by a solvent rinse.

Next, the wafers are hard-baked, inspected to determine accuracy, and etched by wet (acid bath) or dry (plasma vapor) mechanisms. Once etching is complete, the photoresist is stripped off the wafer using chemical baths or plasma techniques.

In another step of the fabrication process, "dopant" atoms are either diffused into the wafer in diffusion furnaces or accelerated into the wafer using "ion implantation." Fumes from the vapor deposition furnaces are oxidized in 'burn boxes.' The oxidized gases are then vented to scrubber control systems. Additional material may be layered on the wafer surface in vapor and crystal (epitaxial) deposition furnaces. Metallization to interconnect uppermost circuit layers is performed by deposition (using "sputtering" systems) or evaporation.

In addition to the fabrication clean room, the building houses a chemical mixing room. This room contains vented stations and chemical cabinets.

Vented gas cabinets, vacuum pumps and chemical drains are located in chases between the processing areas of the fab.

In the two assembly areas, a series of processing and quality control steps are incorporated that produce integrated circuits from the wafers. Wafers are cut (or 'diced') into the individual units (or die) they are comprised of. The die are then put into the circuit packages and the wires are ultrasonically bonded. The resulting integrated circuits are tested for a wide variety of parameters including tolerance, temperature and humidity changes, endurance, and electrical

conductivity. Vented equipment includes degreasers, die wash units, bake ovens, fine leak systems, furnaces, and stations dedicated to the cleaning of product parts.

Wet stations that house vats containing a variety of acid and caustic compounds are located in the two areas. Approximately 20 stations are utilized. Five of these stations are estimated to be heated, and five stations contain vats of chemicals that are covered. Approximately half of the 20 stations are dedicated to the use of solvents.

Three wet scrubber control systems handle equipment exhausts from building 63. Two of these systems, F63S01 and F63S02, are located on the east side of the building at ground level. F63S01 provides exhaust and pollution control for acid exhaust drawn from the equipment in the wafer fab and chemical mix room, while F63S02 provides solvent exhaust for the fab, the chemical mix room, and one of the assembly areas. The third scrubber control system, F63S03, is located on the roof and provides solvent exhaust for equipment in the other assembly area.

Each of the two assembly areas house a fine leak system that utilize Krypton 85 gas to pressurize electronic components and to detect faulty hermetic seals in circuits. Each system has its own exhaust fan. The systems and the corresponding roof fans are permitted under a radioactive materials license by the State of Florida's HRS Office of Radiation Control (license # 662-3).

In addition, the furnaces used for the burn-in of parts in Major Programs assembly are directly vented to the roof via vent pipes.

#### 4. Building 58

The primary manufacturing operations in building 58 are assembly and testing of integrated circuits. In the Assembly and Test areas, a series of processing and quality control steps are incorporated to produce the final product. Wafers are cut (or 'diced') into individual units (or die) they are comprised of. The die are then put into circuit packages and the wires are ultrasonically bonded. The resulting integrated circuits are tested for a wide variety of parameters including tolerance, temperature and humidity changes, endurance, and electrical conductivity. Vented equipment includes saws, soldering stations, degreasers, die wash units, bake ovens, fine leak test systems, compressors, furnaces, chemical cabinets, and wet stations dedicated to the cleaning of product parts.

In addition, the two-story building houses a Brand area, a P.C. Board Technology Lab, and a Product Development Lab.

In the Brand area, product information is stamped onto the



integrated circuit packages. Vented equipment includes wet stations, branders, and chemical storage cabinets.

The P.C. Board Technology and Product Development Labs manufacture printed circuit boards. Examples of equipment attached to the exhaust system are coaters, ovens, etchers, and wet stations. Defective parts are tested in the Reliability Lab and the etchers and wet stations are vented.

Scrubber control system F58S01 treats caustic and corrosive contaminated exhaust from the Assembly, Test, Brand, and Reliability Lab areas. Scrubber control system F58S02 vents contaminated air streams from the Analog Product Development Lab. Exhaust fan F58E01 provides venting for equipment in the Assembly, Test, Brand, and P.C. Board Technology Labs. The scrubbers are located on the roof, and the fan is mounted on the west side of the building at ground level.

In a room on the east side of the building, an automatic abrading machine is used to remove stamped-on labels from semiconductors. The exhaust generated from the process is contaminated with alumina powder. A Torit Model TD 486 dust collector is employed to capture the dust. The dust collector resides on the exterior wall of the building.

The assembly area houses a fine leak system that utilizes Krypton 85 gas to pressurize electronic components and to detect faulty hermetic seals in circuits. The system has its own exhaust fan, and is permitted under a radioactive materials license by the State of Florida's HRS Office of Radiation Control (license # 662-3).

## 5. General

A material balance scheme will be used to account for the annual VOC/solvent emissions released into the atmosphere by the sources and facility. A program of sampling and analysis will be used to assess the VOC/solvent emissions from each building/source. The emissions shall be verifiable on a monthly basis pursuant to EPA's policy.

The Standard Industrial Classification Codes are:

- o Major Group 36: Electrical and Electronic Machinery, Equipment, and Supplies
- o Industry Group No. 367: Electronic Components and Accessories
- o Industry No. 3674: Semiconductors and Related Devices

The following table presents the projected potential VOC/solvent emissions from each building/source and the facility:

Table 2

Building	Potential VOC/solvent Emissions (TPY)
4	10.96
51	33.29
54	95.65
57	1.66
58	3.24
59	0.50
60	min.
61	0.25
62	0.83
63	6.14
Total:	<u>152.52</u>

Note: Annual hours of operation at 8760.

Since the potential emissions are less than 250 TPY for the facility, the potential emissions projected from Buildings 51, 62, 63 and 58 will be reviewed pursuant to F.A.C. Rule 17-2.520, Sources Not Subject to Prevention of Significant Deterioration or Nonattainment Requirements.

Since there is no specific emission limiting standard contained in F.A.C. Rule 17-2.600 nor is there any standards of performance for new stationary sources contained in F.A.C. Rule 17-2.660, the sources will be permitted in accordance with F.A.C. Rule 17-2.620, General Pollutant Emission Limiting Standards.

In F.A.C. Rule 17-2.620(1)(a), no person shall store, pump, handle, process, load, unload or use in any process or installation volatile organic compounds or organic solvents without applying known and existing vapor emission control devices or systems deemed necessary and ordered by the Department. Pursuant to F.A.C. Rule 17-2.620(2), no person shall cause, suffer, allow or permit the discharge of air pollutants which cause or contribute to an objectionable odor. Objectionable odor is defined as any odor present in the outdoor atmosphere, which by itself or in combination with other odors, is or may be harmful or injurious to human health or welfare, which unreasonably interferes with the comfortable use and enjoyment of life or property, or which creates a nuisance according to F.A.C. Rule 17-2.100(132).

The buildings/sources operations are subject to the provisions of F.A.C. Rules 17-2.240: Circumvention; 17-2.250: Excess Emissions; and, 17-4.130: Plant Operation - Problems.

### III. Summary of Emissions

#### A. Emission Limitations

The regulated pollutant emissions from these buildings/sources are VOC/solvents in accordance with F.A.C. Rule 17-2.620.

Specific acid solutions are also being used during the manufacturing operations. There are no specific emission limiting standards for these specific acids. However, the acid vapors will be scrubbed to reduce emissions.

The following table presents the maximum allowable VOC/solvent emissions and the potential acid vapor emissions from Buildings 51, 62, 63 and 58:

Table 3

Building	Maximum Allowable VOC/Solvent Emissions	Potential Acid Vapor Emissions
51	33.3	3.7
62	0.8	0.2
63	6.1	0.2
58	3.2	0.3

Note: Annual hours of operation at 8760.

The permitted emissions are in compliance with all requirements of F.A.C. Rules 17-2 and 17-4.

#### B. Air Quality Impacts

From the technical review of the application packages and supplementary material, an air quality analysis was not required.

### IV. Conclusion

The maximum allowable VOC/solvent emissions from Buildings 51, 62, 63 and 58 are in compliance with F.A.C. Rules 17-2 and 17-4. Even though there are no emission standards for acid vapors, the applicant has installed scrubber systems to control their emissions.

A system of material balance and sampling/analysis will be used to account for pollutant emissions from the facility and each building/source and their scrubber systems. The emissions shall be verifiable on a monthly basis pursuant to EPA's policy.

The General and Specific Conditions listed in the proposed permits (attached) will ensure compliance with all applicable requirements of F.A.C. Rules 17-2 and 17-4.

Based on the information provided by Harris Semiconductor, the Department has reasonable assurance that the consolidation of multiple permits previously issued for these sources/buildings, as described in this evaluation, and subject to the conditions proposed herein, will not cause or contribute to a violation of any air quality standard, PSD increment, or any other technical provision of Chapter 17-2 of the Florida Administrative Code.



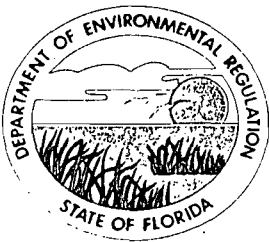

## Florida Department of Environmental Regulation

Twin Towers Office Bldg. • 2600 Blair Stone Road • Tallahassee, Florida 32399-2400

Bob Martinez, Governor

Dale Twachtman, Secretary

John Shearer, Assistant Secretary

**PERMITTEE:**

Harris Semiconductor  
P. O. Box 883  
Melbourne, Florida 32901

Permit Number: AC 05-157786

Expiration Date: April 30, 1990

County: Brevard

Latitude/Longitude: 28° 01' 20" N  
80° 36' 10" W

Project: Building 51

This permit is issued under the provisions of Chapter 403, Florida Statutes, and Florida Administrative Code (F.A.C.) Rules 17-2 and 17-4. The above named permittee is hereby authorized to perform the work or operate the facility shown on the application and approved drawing(s), plans, and other documents attached hereto or on file with the Department and made a part hereof and specifically described as follows:

For the permitting of Building 51, a wafer fabrication source, of which there are two clean room modules. The scrubber control systems are:

- o F51S01: a Tri Mer Corp. 9,500 scfm horizontal counter-flow fume scrubber using polypropylene packing for acid gas removal; Model No. F/W 3;
- o F51S02: a Duall Ind. 10,000 scfm horizontal cross-flow fume scrubber using polypropylene packing for VOC/solvent removal; Model No. F-101;
- o F51S03: a Duall Ind. 24,000 scfm horizontal cross-flow fume scrubber using polypropylene packing for acid gas and VOC/solvent removal; Model No. F-101;
- o F51S04: the same as F51S03; and,
- o F51S05: a Harrison 18,000 scfm horizontal cross-flow fume scrubber using plastic saddle packing for VOC/solvent removal; Model No. HF-180.

The building/source is located at the permittee's existing facility located on Palm Bay Road in the City of Palm Bay. The UTM coordinates are Zone 17, 538.7 km East and 3100.9 km North.

The Source Classification Codes are: Major Group 36

- o Cold Solvent Cleaning/ Stripping 4-01-003-99 Tons VOC/solvent consumed

The source shall be in accordance with the permit application and plans, documents, amendments, and drawings except as otherwise noted in the General and Specific Conditions.

Attachments to be Incorporated:

1. Application to Construct Air Pollution Sources, DER Form 17-1.202(1), and Mr. James R. Kolanek's cover letter received November 28, 1988.
2. Technical Evaluation and Preliminary Determination dated February 7, 1989.

PERMITTEE:  
Harris Semiconductor

Permit Number: AC 05-157786  
Expiration Date: April 30, 1990

**GENERAL CONDITIONS:**

1. The terms, conditions, requirements, limitations, and restrictions set forth herein are "Permit Conditions" and as such are binding upon the permittee and enforceable pursuant to the authority of Sections 403.161, 403.727, or 403.859 through 403.861, Florida Statutes. The permittee is hereby placed on notice that the Department will review this permit periodically and may initiate enforcement action for any violation of the "Permit Conditions" by the permittee, its agents, employees, servants or representatives.

2. This permit is valid only for the specific processes and operations applied for and indicated in the approved drawings or exhibits. Any unauthorized deviation from the approved drawings, exhibits, specifications, or conditions of this permit may constitute grounds for revocation and enforcement action by the Department.

3. As provided in Subsections 403.087(6) and 403.722(5), Florida Statutes, the issuance of this permit does not convey any vested rights or any exclusive privileges. Nor does it authorize any injury to public or private property or any invasion of personal rights, nor any infringement of federal, state or local laws or regulations. This permit does not constitute a waiver of or approval of any other Department permit that may be required for other aspects of the total project which are not addressed in the permit.

4. This permit conveys no title to land or water, does not constitute state recognition or acknowledgement of title, and does not constitute authority for the use of submerged lands unless herein provided and the necessary title or leasehold interests have been obtained from the state. Only the Trustees of the Internal Improvement Trust Fund may express state opinion as to title.

5. This permit does not relieve the permittee from liability for harm or injury to human health or welfare, animal, plant or aquatic life or property and penalties therefore caused by the construction or operation of this permitted source, nor does it allow the permittee to cause pollution in contravention of Florida Statutes and Department rules, unless specifically authorized by an order from the Department.

PERMITTEE:  
Harris Semiconductor

Permit Number: AC 05-157786  
Expiration Date: April 30, 1990

**GENERAL CONDITIONS:**

6. The permittee shall at all times properly operate and maintain the facility and systems of treatment and control (and related appurtenances) that are installed or used by the permittee to achieve compliance with the conditions of this permit, as required by Department rules. This provision includes the operation of backup or auxiliary facilities or similar systems when necessary to achieve compliance with the conditions of the permit and when required by Department rules.

7. The permittee, by accepting this permit, specifically agrees to allow authorized Department personnel, upon presentation of credentials or other documents as may be required by law, access to the premises, at reasonable times, where the permitted activity is located or conducted for the purpose of:

- a. Having access to and copying any records that must be kept under the conditions of the permit;
- b. Inspecting the facility, equipment, practices, or operations regulated or required under this permit; and
- c. Sampling or monitoring any substances or parameters at any location reasonably necessary to assure compliance with this permit or Department rules.

Reasonable time may depend on the nature of the concern being investigated.

8. If, for any reason, the permittee does not comply with or will be unable to comply with any condition or limitation specified in this permit, the permittee shall immediately notify and provide the Department with the following information:

- a. a description of and cause of non-compliance; and
- b. the period of noncompliance, including exact dates and times; or, if not corrected, the anticipated time the noncompliance is expected to continue, and steps being taken to reduce, eliminate, and prevent recurrence of the noncompliance.

PERMITTEE:  
Harris Semiconductor

Permit Number: AC 05-157786  
Expiration Date: April 30, 1990

**GENERAL CONDITIONS:**

The permittee shall be responsible for any and all damages which may result and may be subject to enforcement action by the Department for penalties or revocation of this permit.

9. In accepting this permit, the permittee understands and agrees that all records, notes, monitoring data and other information relating to the construction or operation of this permitted source, which are submitted to the Department, may be used by the Department as evidence in any enforcement case arising under the Florida Statutes or Department rules, except where such use is proscribed by Sections 403.73 and 403.111, Florida Statutes.

10. The permittee agrees to comply with changes in Department rules and Florida Statutes after a reasonable time for compliance, provided however, the permittee does not waive any other rights granted by Florida Statutes or Department rules.

11. This permit is transferable only upon Department approval in accordance with Florida Administrative Code Rules 17-4.12 and 17-30.30, as applicable. The permittee shall be liable for any noncompliance of the permitted activity until the transfer is approved by the Department.

12. This permit is required to be kept at the work site of the permitted activity during the entire period of construction or operation.

13. This permit also constitutes:

- ( ) Determination of Best Available Control Technology (BACT)
- ( ) Determination of Prevention of Significant Deterioration (PSD).
- ( ) Compliance with New Source Performance Standards.

14. The permittee shall comply with the following monitoring and record keeping requirements:

- a. Upon request, the permittee shall furnish all records and plans required under department rules. The retention period for all records will be extended automatically, unless otherwise stipulated by the Department, during the course of any unresolved enforcement action.



**PERMITTEE:**  
Harris Semiconductor

Permit Number: AC 05-157786  
Expiration Date: April 30, 1990

**GENERAL CONDITIONS:**

- b. The permittee shall retain at the facility or other location designated by this permit records of all monitoring information (including all calibration and maintenance records and all original strip chart recordings for continuous monitoring instrumentation), copies of all reports required by this permit, and records of all data used to complete the application for this permit. The time period of retention shall be at least three years from the date of the sample, measurement, report or application unless otherwise specified by Department rule.
- c. Records of monitoring information shall include:
- the date, exact place, and time of sampling or measurements;
  - the person responsible for performing the sampling or measurements;
  - the date(s) analyses were performed;
  - the person responsible for performing the analyses;
  - the analytical techniques or methods used; and
  - the results of such analyses.

15. When requested by the Department, the permittee shall within a reasonable time furnish any information required by law which is needed to determine compliance with the permit. If the permittee becomes aware that relevant facts were not submitted or were incorrect in the permit application or in any report to the Department, such facts or information shall be submitted or corrected promptly.

**SPECIFIC CONDITIONS:**

1. The maximum allowable VOC/solvent emissions from Building No. 51 shall be 33.3 tons per year.
2. The VOC/solvent vapor exhaust scrubber must be on during the working hours.
3. Annual operation shall be 8760 hours per year.
4. Objectionable odors shall not be allowed off plant property.

PERMITTEE:  
Harris Semiconductor

Permit Number: AC 05-157786  
Expiration Date: April 30, 1990

**SPECIFIC CONDITIONS:**

5. An inspection and maintenance plan shall be submitted to the DER's Central Florida District office as part of the operating permit application. The plan shall include provisions for the prevention and correction of VOC/solvent losses from leaks and equipment malfunctions.

6. By March 31 of each calendar year, an annual operating report shall be submitted to the DER's Central Florida District office demonstrating compliance with the VOC/solvent emissions limit for Building No. 51. The emissions shall be determined by a material balance scheme, verifiable on a monthly basis, and shall include the following:

- a) a beginning inventory of full containers, cylinders and storage tanks at the beginning of each calendar year;
- b) plus all purchased deliveries after the beginning inventory (verifiable by invoices);
- c) minus all quantities picked-up and shipped-off the premise after the beginning inventory (verifiable by invoices);
- d) minus all quantities deep well injected during the calendar year, justified by assumptions and established scrubber efficiencies; and,
- e) minus an ending inventory of full containers, cylinders, and storage tanks; and, should occur at the beginning of the following calendar year.

7. Each scrubber system's efficiency and potential VOC/solvent emissions shall be established by a sampling and analysis program, which includes:

- a) a sample shall be taken annually from each scrubber stack and analyzed using EPA Reference Method 25;
- b) the DER's Central Florida District office shall receive 15 days notice in writing prior to sampling; and,
- c) the report, summarizing the sampling results, shall be submitted to the DER's Central Florida District office within 45 days after the last test run is completed.

8. This permit will supercede all other permits previously issued on this source/Building No. 51.

9. The permittee, for good cause, may request that this construction permit be extended. Such a request shall be submitted to the BAQM prior to 60 days before the expiration of the permit (F.A.C. Rule 17-4.090).

10. An application for an operation permit must be submitted to the Central Florida District office at least 90 days prior to

PERMITEE:  
Harris Semiconductor

Permit Number: AC 05-157786  
Expiration Number: April 30, 1990

**SPECIFIC CONDITIONS:**

the expiration date of this construction permit or within 45 days after completion of compliance testing, whichever comes first. To properly apply for an operation permit, the applicant shall submit the appropriate application form, fee, certification that construction was completed noting any deviations from the conditions in the construction permit, and compliance test reports as required by this permit (F.A.C. Rule 17-4.220).

11. Building No. 51 is subject to the provisions of F.A.C. Rules 17-2.240: Circumvention; 17-2.250: Excess Emissions; and, 17-4.130: Plant Operation - Problems.

12. Any modification pursuant to F.A.C. Rule 17-2.100(119), Modification, shall be submitted to the DER's Central Florida District office and the Bureau of Air Quality Management office for approval.

13. Projected potential acid emissions are 3.7 TPY.

14. The source/Building No. 51 is subject to all applicable provisions of F.A.C. Rules 17-2 and 17-4.

Issued this \_\_\_\_\_ day of \_\_\_\_\_,  
19\_\_.

**STATE OF FLORIDA DEPARTMENT  
OF ENVIRONMENTAL REGULATION**

\_\_\_\_\_  
Dale Twachtmann, Secretary

ATTACHMENT 1

Available Upon Request

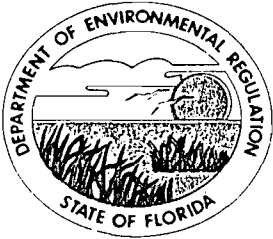

# Florida Department of Environmental Regulation

Twin Towers Office Bldg. • 2600 Blair Stone Road • Tallahassee, Florida 32399-2400

Bob Martinez, Governor

Dale Twachtmann, Secretary

John Shearer, Assistant Secretary

**PERMITTEE:**  
**Harris Semiconductor**  
**P. O. Box 883**  
**Melbourne, Florida 32901**

**Permit Number: AC 05-157787**  
**Expiration Date: April 30, 1990**  
**County: Brevard**  
**Latitude/Longitude: 28° 01' 20" N**  
**80° 36' 10" W**

**Project: Building 62**

This permit is issued under the provisions of Chapter 403, Florida Statutes, and Florida Administrative Code (F.A.C.) Rules 17-2 and 17-4. The above named permittee is hereby authorized to perform the work or operate the facility shown on the application and approved drawing(s), plans, and other documents attached hereto or on file with the Department and made a part hereof and specifically described as follows:

For the permitting of Building 62, which houses a research and development laboratory, a prototype wafer fabrication process, and an analytical services laboratory. The scrubber control systems are:

- o F62S01: a Beverly Pacific 24,000 scfm horizontal cross-flow vapor scrubber using polypropylene packing for acid gas removal; Model No. PS-24T; and,
- o F62S02: a Beverly Pacific 12,000 scfm vertical counter-current vapor scrubber using polypropylene packing for VOC/solvent removal; Model No. PS-12VT.

The building/source is located at the permittee's existing facility located on Palm Bay Road in the City of Palm Bay. The UTM coordinates are Zone 17, 538.7 km East and 3100.9 km North.

The Source Classification Codes are: Major Group 36

- o Cold Solvent Cleaning/ Stripping 4-01-003-99 Tons VOC/solvent consumed

The source shall be in accordance with the permit application and plans, documents, amendments, and drawings except as otherwise noted in the General and Specific Conditions.

Attachments to be Incorporated:

1. Application to Construct Air Pollution Sources, DER Form 17-1.202(1), and Mr. James R. Kolanek's cover letter received November 28, 1988.
2. Technical Evaluation and Preliminary Determination dated February 7, 1989.

**PERMITTEE:**  
Harris Semiconductor

**Permit Number:** AC 05-157787  
**Expiration Date:** April 30, 1990

**GENERAL CONDITIONS:**

1. The terms, conditions, requirements, limitations, and restrictions set forth herein are "Permit Conditions" and as such are binding upon the permittee and enforceable pursuant to the authority of Sections 403.161, 403.727, or 403.859 through 403.861, Florida Statutes. The permittee is hereby placed on notice that the Department will review this permit periodically and may initiate enforcement action for any violation of the "Permit Conditions" by the permittee, its agents, employees, servants or representatives.
2. This permit is valid only for the specific processes and operations applied for and indicated in the approved drawings or exhibits. Any unauthorized deviation from the approved drawings, exhibits, specifications, or conditions of this permit may constitute grounds for revocation and enforcement action by the Department.
3. As provided in Subsections 403.087(6) and 403.722(5), Florida Statutes, the issuance of this permit does not convey any vested rights or any exclusive privileges. Nor does it authorize any injury to public or private property or any invasion of personal rights, nor any infringement of federal, state or local laws or regulations. This permit does not constitute a waiver of or approval of any other Department permit that may be required for other aspects of the total project which are not addressed in the permit.
4. This permit conveys no title to land or water, does not constitute state recognition or acknowledgement of title, and does not constitute authority for the use of submerged lands unless herein provided and the necessary title or leasehold interests have been obtained from the state. Only the Trustees of the Internal Improvement Trust Fund may express state opinion as to title.
5. This permit does not relieve the permittee from liability for harm or injury to human health or welfare, animal, plant or aquatic life or property and penalties therefore caused by the construction or operation of this permitted source, nor does it allow the permittee to cause pollution in contravention of Florida Statutes and Department rules, unless specifically authorized by an order from the Department.

PERMITTEE:  
Harris Semiconductor

Permit Number: AC 05-157787  
Expiration Date: April 30, 1990

**GENERAL CONDITIONS:**

6. The permittee shall at all times properly operate and maintain the facility and systems of treatment and control (and related appurtenances) that are installed or used by the permittee to achieve compliance with the conditions of this permit, as required by Department rules. This provision includes the operation of backup or auxiliary facilities or similar systems when necessary to achieve compliance with the conditions of the permit and when required by Department rules.

7. The permittee, by accepting this permit, specifically agrees to allow authorized Department personnel, upon presentation of credentials or other documents as may be required by law, access to the premises, at reasonable times, where the permitted activity is located or conducted for the purpose of:

- a. Having access to and copying any records that must be kept under the conditions of the permit;
- b. Inspecting the facility, equipment, practices, or operations regulated or required under this permit; and
- c. Sampling or monitoring any substances or parameters at any location reasonably necessary to assure compliance with this permit or Department rules.

Reasonable time may depend on the nature of the concern being investigated.

8. If, for any reason, the permittee does not comply with or will be unable to comply with any condition or limitation specified in this permit, the permittee shall immediately notify and provide the Department with the following information:

- a. a description of and cause of non-compliance; and
- b. the period of noncompliance, including exact dates and times; or, if not corrected, the anticipated time the noncompliance is expected to continue, and steps being taken to reduce, eliminate, and prevent recurrence of the noncompliance.

PERMITTEE:  
Harris Semiconductor

Permit Number: AC 05-157787  
Expiration Date: April 30, 1990

**GENERAL CONDITIONS:**

The permittee shall be responsible for any and all damages which may result and may be subject to enforcement action by the Department for penalties or revocation of this permit.

9. In accepting this permit, the permittee understands and agrees that all records, notes, monitoring data and other information relating to the construction or operation of this permitted source, which are submitted to the Department, may be used by the Department as evidence in any enforcement case arising under the Florida Statutes or Department rules, except where such use is proscribed by Sections 403.73 and 403.111, Florida Statutes.

10. The permittee agrees to comply with changes in Department rules and Florida Statutes after a reasonable time for compliance, provided however, the permittee does not waive any other rights granted by Florida Statutes or Department rules.

11. This permit is transferable only upon Department approval in accordance with Florida Administrative Code Rules 17-4.12 and 17- 30.30, as applicable. The permittee shall be liable for any noncompliance of the permitted activity until the transfer is approved by the Department.

12. This permit is required to be kept at the work site of the permitted activity during the entire period of construction or operation.

13. This permit also constitutes:

- ( ) Determination of Best Available Control Technology (BACT)
- ( ) Determination of Prevention of Significant Deterioration (PSD).
- ( ) Compliance with New Source Performance Standards.

14. The permittee shall comply with the following monitoring and record keeping requirements:

- a. Upon request, the permittee shall furnish all records and plans required under department rules. The retention period for all records will be extended automatically, unless otherwise stipulated by the Department, during the course of any unresolved enforcement action.



**PERMITTEE:**  
Harris Semiconductor

Permit Number: AC 05-157787  
Expiration Date: April 30, 1990

**GENERAL CONDITIONS:**

b. The permittee shall retain at the facility or other location designated by this permit records of all monitoring information (including all calibration and maintenance records and all original strip chart recordings for continuous monitoring instrumentation), copies of all reports required by this permit, and records of all data used to complete the application for this permit. The time period of retention shall be at least three years from the date of the sample, measurement, report or application unless otherwise specified by Department rule.

c. Records of monitoring information shall include:

- the date, exact place, and time of sampling or measurements;
- the person responsible for performing the sampling or measurements;
- the date(s) analyses were performed;
- the person responsible for performing the analyses;
- the analytical techniques or methods used; and
- the results of such analyses.

15. When requested by the Department, the permittee shall within a reasonable time furnish any information required by law which is needed to determine compliance with the permit. If the permittee becomes aware that relevant facts were not submitted or were incorrect in the permit application or in any report to the Department, such facts or information shall be submitted or corrected promptly.

**SPECIFIC CONDITIONS:**

1. The maximum allowable VOC/solvent emissions from Building No. 62 shall be 0.8 tons per year.
2. The VOC/solvent vapor exhaust scrubber must be on during the working hours.
3. Annual operation shall be 8760 hours per year.
4. Objectionable odors shall not be allowed off plant property.

PERMITTEE:  
Harris Semiconductor

Permit Number: AC 05-157787  
Expiration Date: April 30, 1990

**SPECIFIC CONDITIONS:**

5. An inspection and maintenance plan shall be submitted to the DER's Central Florida District office as part of the operating permit application. The plan shall include provisions for the prevention and correction of VOC/solvent losses from leaks and equipment malfunctions.

6. By March 31 of each calendar year, an annual operating report shall be submitted to the DER's Central Florida District office demonstrating compliance with the VOC/solvent emissions limit for Building No. 62. The emissions shall be determined by a material balance scheme, verifiable on a monthly basis, and shall include the following:

- a) a beginning inventory of full containers, cylinders and storage tanks at the beginning of each calendar year;
- b) plus all purchased deliveries after the beginning inventory (verifiable by invoices);
- c) minus all quantities picked-up and shipped-off the premise after the beginning inventory (verifiable by invoices);
- d) minus all quantities deep well injected during the calendar year, justified by assumptions and established scrubber efficiencies; and,
- e) minus an ending inventory of full containers, cylinders, and storage tanks; and, should occur at the beginning of the following calendar year.

7. Each scrubber system's efficiency and potential VOC/solvent emissions shall be established by a sampling and analysis program, which includes:

- a) a sample shall be taken annually from each scrubber stack and analyzed using EPA Reference Method 25;
- b) the DER's Central Florida District office shall receive 15 days notice in writing prior to sampling; and,
- c) the report, summarizing the sampling results, shall be submitted to the DER's Central Florida District office within 45 days after the last test run is completed.

8. This permit will supercede all other permits previously issued on this source/Building No. 62.

9. The permittee shall, for good cause, may request that this construction permit be extended. Such a request shall be submitted to the BAQM prior to 60 days before the expiration of the permit (F.A.C. Rule 17-4.090).

10. An application for an operation permit must be submitted to the Central Florida District office at least 90 days prior to

PERMITEE:  
Harris Semiconductor

Permit Number: AC 05-157787  
Expiration Number: April 30, 1990

**SPECIFIC CONDITIONS:**

the expiration date of this construction permit or within 45 days after completion of compliance testing, whichever occurs first. To properly apply for an operation permit, the applicant shall submit the appropriate application form, fee, certification that construction was completed noting any deviations from the conditions in the construction permit, and compliance test reports as required by this permit (F.A.C. Rule 17-4.220).

11. Building No. 62 is subject to the provisions of F.A.C. Rules 17-2.240: Circumvention; 17-2.250: Excess Emissions; and, 17-4.130: Plant Operation - Problems.

12. Any modification pursuant to F.A.C. Rule 17-2.100(119), Modification, shall be submitted to the DER's Central Florida District office and the Bureau of Air Quality Management office for approval.

13. Projected potential acid emissions are 0.2 TPY.

14. The source/Building No. 62 is subject to all applicable provisions of F.A.C. Rules 17-2 and 17-4.

Issued this \_\_\_\_\_ day of \_\_\_\_\_,  
19\_\_.

**STATE OF FLORIDA DEPARTMENT  
OF ENVIRONMENTAL REGULATION**

\_\_\_\_\_  
Dale Twachtmann, Secretary

ATTACHMENT 1

Available Upon Request

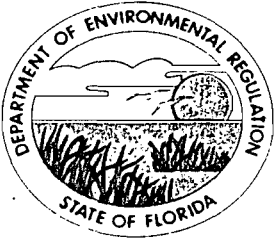

# Florida Department of Environmental Regulation

Twin Towers Office Bldg. • 2600 Blair Stone Road • Tallahassee, Florida 32399-2400

Bob Martinez, Governor

Dale Twachtman, Secretary

John Shearer, Assistant Secretary

**PERMITTEE:**

Harris Semiconductor  
P. O. Box 883  
Melbourne, Florida 32901

Permit Number: AC 05-158237

Expiration Date: April 30, 1990

County: Brevard

Latitude/Longitude: 28° 01' 20" N  
80° 36' 10" W

Project: Building 63

This permit is issued under the provisions of Chapter 403, Florida Statutes, and Florida Administrative Code (F.A.C.) Rules 17-2 and 17-4. The above named permittee is hereby authorized to perform the work or operate the facility shown on the application and approved drawing(s), plans, and other documents attached hereto or on file with the Department and made a part hereof and specifically described as follows:

For the permitting of Building 63, which is a wafer fabrication and assembly source. The scrubber control systems are:

- o F63S01: a Beverly Pacific 50,000 scfm horizontal cross-flow vapor scrubber using polypropylene packing for acid gas removal; Model No. CB-60;
- o F63S02: a Beverly Pacific 10,000 scfm vertical counter-current vapor scrubber using polypropylene packing for VOC/solvent removal; Model No. PS-12VT; and,
- o F63S03: a Tri Mer Corp. 6,000 scfm horizontal counter-flow fume scrubber using polypropylene packing for VOC/solvent removal; Model No. F/WR-5.

The building/source is located at the permittee's existing facility located on Palm Bay Road in the City of Palm Bay. The UTM coordinates are Zone 17, 538.7 km East and 3100.9 km North.

The Source Classification Codes are: Major Group 36

- o Cold Solvent Cleaning/ 4-01-003-99 Tons VOC/solvent Stripping consumed

The source shall be in accordance with the permit application and plans, documents, amendments, and drawings except as otherwise noted in the General and Specific Conditions.

**Attachments to be Incorporated:**

1. Application to Construct Air Pollution Sources, DER Form 17-1.202(1), and Mr. James R. Kolanek's cover letter received December 9, 1988.
2. Technical Evaluation and Preliminary Determination dated February 7, 1989.

**PERMITTEE:**  
Harris Semiconductor

**Permit Number:** AC 05-158237  
**Expiration Date:** April 30, 1990

**GENERAL CONDITIONS:**

1. The terms, conditions, requirements, limitations, and restrictions set forth herein are "Permit Conditions" and as such are binding upon the permittee and enforceable pursuant to the authority of Sections 403.161, 403.727, or 403.859 through 403.861, Florida Statutes. The permittee is hereby placed on notice that the Department will review this permit periodically and may initiate enforcement action for any violation of the "Permit Conditions" by the permittee, its agents, employees, servants or representatives.

2. This permit is valid only for the specific processes and operations applied for and indicated in the approved drawings or exhibits. Any unauthorized deviation from the approved drawings, exhibits, specifications, or conditions of this permit may constitute grounds for revocation and enforcement action by the Department.

3. As provided in Subsections 403.087(6) and 403.722(5), Florida Statutes, the issuance of this permit does not convey any vested rights or any exclusive privileges. Nor does it authorize any injury to public or private property or any invasion of personal rights, nor any infringement of federal, state or local laws or regulations. This permit does not constitute a waiver of or approval of any other Department permit that may be required for other aspects of the total project which are not addressed in the permit.

4. This permit conveys no title to land or water, does not constitute state recognition or acknowledgement of title, and does not constitute authority for the use of submerged lands unless herein provided and the necessary title or leasehold interests have been obtained from the state. Only the Trustees of the Internal Improvement Trust Fund may express state opinion as to title.

5. This permit does not relieve the permittee from liability for harm or injury to human health or welfare, animal, plant or aquatic life or property and penalties therefore caused by the construction or operation of this permitted source, nor does it allow the permittee to cause pollution in contravention of Florida Statutes and Department rules, unless specifically authorized by an order from the Department.

PERMITTEE:  
Harris Semiconductor

Permit Number: AC 05-158237  
Expiration Date: April 30, 1990

**GENERAL CONDITIONS:**

6. The permittee shall at all times properly operate and maintain the facility and systems of treatment and control (and related appurtenances) that are installed or used by the permittee to achieve compliance with the conditions of this permit, as required by Department rules. This provision includes the operation of backup or auxiliary facilities or similar systems when necessary to achieve compliance with the conditions of the permit and when required by Department rules.

7. The permittee, by accepting this permit, specifically agrees to allow authorized Department personnel, upon presentation of credentials or other documents as may be required by law, access to the premises, at reasonable times, where the permitted activity is located or conducted for the purpose of:

- a. Having access to and copying any records that must be kept under the conditions of the permit;
- b. Inspecting the facility, equipment, practices, or operations regulated or required under this permit; and
- c. Sampling or monitoring any substances or parameters at any location reasonably necessary to assure compliance with this permit or Department rules.

Reasonable time may depend on the nature of the concern being investigated.

8. If, for any reason, the permittee does not comply with or will be unable to comply with any condition or limitation specified in this permit, the permittee shall immediately notify and provide the Department with the following information:

- a. a description of and cause of non-compliance; and
- b. the period of noncompliance, including exact dates and times; or, if not corrected, the anticipated time the noncompliance is expected to continue, and steps being taken to reduce, eliminate, and prevent recurrence of the noncompliance.

PERMITTEE:  
Harris Semiconductor

Permit Number: AC 05-158237  
Expiration Date: April 30, 1990

**GENERAL CONDITIONS:**

The permittee shall be responsible for any and all damages which may result and may be subject to enforcement action by the Department for penalties or revocation of this permit.

9. In accepting this permit, the permittee understands and agrees that all records, notes, monitoring data and other information relating to the construction or operation of this permitted source, which are submitted to the Department, may be used by the Department as evidence in any enforcement case arising under the Florida Statutes or Department rules, except where such use is proscribed by Sections 403.73 and 403.111, Florida Statutes.

10. The permittee agrees to comply with changes in Department rules and Florida Statutes after a reasonable time for compliance, provided however, the permittee does not waive any other rights granted by Florida Statutes or Department rules.

11. This permit is transferable only upon Department approval in accordance with Florida Administrative Code Rules 17-4.12 and 17- 30.30, as applicable. The permittee shall be liable for any noncompliance of the permitted activity until the transfer is approved by the Department.

12. This permit is required to be kept at the work site of the permitted activity during the entire period of construction or operation.

13. This permit also constitutes:

- ( ) Determination of Best Available Control Technology (BACT)
- ( ) Determination of Prevention of Significant Deterioration (PSD).
- ( ) Compliance with New Source Performance Standards.

14. The permittee shall comply with the following monitoring and record keeping requirements:

- a. Upon request, the permittee shall furnish all records and plans required under department rules. The retention period for all records will be extended automatically, unless otherwise stipulated by the Department, during the course of any unresolved enforcement action.



**PERMITTEE:**  
Harris Semiconductor

**Permit Number:** AC 05-158237  
**Expiration Date:** April 30, 1990

**GENERAL CONDITIONS:**

b. The permittee shall retain at the facility or other location designated by this permit records of all monitoring information (including all calibration and maintenance records and all original strip chart recordings for continuous monitoring instrumentation), copies of all reports required by this permit, and records of all data used to complete the application for this permit. The time period of retention shall be at least three years from the date of the sample, measurement, report or application unless otherwise specified by Department rule.

c. Records of monitoring information shall include:

- the date, exact place, and time of sampling or measurements;
- the person responsible for performing the sampling or measurements;
- the date(s) analyses were performed;
- the person responsible for performing the analyses;
- the analytical techniques or methods used; and
- the results of such analyses.

15. When requested by the Department, the permittee shall within a reasonable time furnish any information required by law which is needed to determine compliance with the permit. If the permittee becomes aware that relevant facts were not submitted or were incorrect in the permit application or in any report to the Department, such facts or information shall be submitted or corrected promptly.

**SPECIFIC CONDITIONS:**

1. The maximum allowable VOC/solvent emissions from Building No. 63 shall be 6.1 tons per year.
2. The VOC/solvent vapor exhaust scrubber must be on during the working hours.
3. Annual operation shall be 8760 hours per year.
4. Objectionable odors shall not be allowed off plant property.

PERMITTEE:  
Harris Semiconductor

Permit Number: AC 05-158237  
Expiration Date: April 30, 1990

**SPECIFIC CONDITIONS:**

5. An inspection and maintenance plan shall be submitted to the DER's Central Florida District office as part of the operating permit application. The plan shall include provisions for the prevention and correction of VOC/solvent losses from leaks and equipment malfunctions.

6. By March 31 of each calendar year, an annual operating report shall be submitted to the DER's Central Florida District office demonstrating compliance with the VOC/solvent emissions limit for Building No. 63. The emissions shall be determined by a material balance scheme, verifiable on a monthly basis, and shall include the following:

- a) a beginning inventory of full containers, cylinders and storage tanks at the beginning of each calendar year;
- b) plus all purchased deliveries after the beginning inventory (verifiable by invoices);
- c) minus all quantities picked-up and shipped-off the premise after the beginning inventory (verifiable by invoices);
- d) minus all quantities deep well injected during the calendar year, justified by assumptions and established scrubber efficiencies; and,
- e) minus an ending inventory of full containers, cylinders, and storage tanks; and, should occur at the beginning of the following calendar year.

7. Each scrubber system's efficiency and potential VOC/solvent emissions shall be established by a sampling and analysis program, which includes:

- a) a sample shall be taken annually from each scrubber stack and analyzed using EPA Reference Method 25;
- b) the DER's Central Florida District office shall receive 15 days notice in writing prior to sampling; and,
- c) the report, summarizing the sampling results, shall be submitted to the DER's Central Florida District office within 45 days after the last test run is completed.

8. This permit will supercede all other permits previously issued on this source/Building No. 63.

9. The permittee, for good cause, may request that this construction permit be extended. Such a request shall be submitted to the BAQM prior to 60 days before the expiration of the permit (F.A.C. Rule 17-4.090).

10. An application for an operation permit must be submitted to the Central Florida District office at least 90 days prior to

PERMITEE:  
Harris Semiconductor

Permit Number: AC 05-158237  
Expiration Number: April 30, 1990

**SPECIFIC CONDITIONS:**

the expiration date of this construction permit or within 45 days after completion of compliance testing, whichever comes first. To properly apply for an operation permit, the applicant shall submit the appropriate application form, fee, certification that construction was completed noting any deviations from the conditions in the construction permit, and compliance test reports as required by this permit (F.A.C. Rule 17-4.220).

11. Building No. 63 is subject to the provisions of F.A.C. Rules 17-2.240: Circumvention; 17-2.250: Excess Emissions; and, 17-4.130: Plant Operation - Problems.

12. Any modification pursuant to F.A.C. Rule 17-2.100(119), Modification, shall be submitted to the DER's Central Florida District office and the Bureau of Air Quality Management office for approval.

13. Projected potential acid emissions are 0.2 TPY.

14. The source/Building No. 63 is subject to all applicable provisions of F.A.C. Rules 17-2 and 17-4.

Issued this \_\_\_\_ day of \_\_\_\_\_,  
19\_\_.

**STATE OF FLORIDA DEPARTMENT  
OF ENVIRONMENTAL REGULATION**

\_\_\_\_\_  
Dale Twachtmann, Secretary

ATTACHMENT 1

Available Upon Request



# Florida Department of Environmental Regulation

Twin Towers Office Bldg. • 2600 Blair Stone Road • Tallahassee, Florida 32399-2400

Bob Martinez, Governor

Dale Twachtmann, Secretary

John Shearer, Assistant Secretary

## PERMITTEE:

Harris Semiconductor  
P. O. Box 883  
Melbourne, Florida 32901

Permit Number: AC 05-159484

Expiration Date: April 30, 1990

County: Brevard

Latitude/Longitude: 28° 01' 20" N  
80° 36' 10" W

Project: Building 58

This permit is issued under the provisions of Chapter 403, Florida Statutes, and Florida Administrative Code (F.A.C.) Rules 17-2 and 17-4. The above named permittee is hereby authorized to perform the work or operate the facility shown on the application and approved drawing(s), plans, and other documents attached hereto or on file with the Department and made a part hereof and specifically described as follows:

For the permitting of Building 58, which is a source whose primary manufacturing operations are assembly and testing of integrated circuits. The scrubber control systems and dust collector system are:

- o F58S01: a Tri Mer Corp. 12,500 scfm horizontal counter-flow vapor scrubber using polypropylene packing for caustic and corrosive vapor removal; Model No. F/W 5;
- o F58S02: a Harrison 3,000 scfm horizontal cross-flow vapor scrubber using plastic saddle packing for VOC/solvent removal; Model No. HF-30; and,
- o F58E01: a Torit 3,000 cfm filter cartridge dust collector with a pulse-jet cleaning cycle; Model No. TD 486.

The building/source is located at the permittee's existing facility located on Palm Bay Road in the City of Palm Bay. The UTM coordinates are Zone 17, 538.7 km East and 3100.9 km North.

The Source Classification Codes are: Major Group 36

- o Cold Solvent Cleaning/ 4-01-003-99 Tons VOC/solvent  
Stripping consumed

The source shall be in accordance with the permit application and plans, documents, amendments, and drawings except as otherwise noted in the General and Specific Conditions.

## Attachments to be Incorporated:

1. Application to Construct Air Pollution Sources, DER Form 17-1.202(1), and Mr. James R. Kolanek's cover letter received January 17, 1989.
2. Technical Evaluation and Preliminary Determination dated February 7, 1989.

PERMITTEE:  
Harris Semiconductor

Permit Number: AC 05-159484  
Expiration Date: April 30, 1990

**GENERAL CONDITIONS:**

1. The terms, conditions, requirements, limitations, and restrictions set forth herein are "Permit Conditions" and as such are binding upon the permittee and enforceable pursuant to the authority of Sections 403.161, 403.727, or 403.859 through 403.861, Florida Statutes. The permittee is hereby placed on notice that the Department will review this permit periodically and may initiate enforcement action for any violation of the "Permit Conditions" by the permittee, its agents, employees, servants or representatives.

2. This permit is valid only for the specific processes and operations applied for and indicated in the approved drawings or exhibits. Any unauthorized deviation from the approved drawings, exhibits, specifications, or conditions of this permit may constitute grounds for revocation and enforcement action by the Department.

3. As provided in Subsections 403.087(6) and 403.722(5), Florida Statutes, the issuance of this permit does not convey any vested rights or any exclusive privileges. Nor does it authorize any injury to public or private property or any invasion of personal rights, nor any infringement of federal, state or local laws or regulations. This permit does not constitute a waiver of or approval of any other Department permit that may be required for other aspects of the total project which are not addressed in the permit.

4. This permit conveys no title to land or water, does not constitute state recognition or acknowledgement of title, and does not constitute authority for the use of submerged lands unless herein provided and the necessary title or leasehold interests have been obtained from the state. Only the Trustees of the Internal Improvement Trust Fund may express state opinion as to title.

5. This permit does not relieve the permittee from liability for harm or injury to human health or welfare, animal, plant or aquatic life or property and penalties therefore caused by the construction or operation of this permitted source, nor does it allow the permittee to cause pollution in contravention of Florida Statutes and Department rules, unless specifically authorized by an order from the Department.

PERMITTEE:  
Harris Semiconductor

Permit Number: AC 05-159484  
Expiration Date: April 30, 1990

**GENERAL CONDITIONS:**

6. The permittee shall at all times properly operate and maintain the facility and systems of treatment and control (and related appurtenances) that are installed or used by the permittee to achieve compliance with the conditions of this permit, as required by Department rules. This provision includes the operation of backup or auxiliary facilities or similar systems when necessary to achieve compliance with the conditions of the permit and when required by Department rules.

7. The permittee, by accepting this permit, specifically agrees to allow authorized Department personnel, upon presentation of credentials or other documents as may be required by law, access to the premises, at reasonable times, where the permitted activity is located or conducted for the purpose of:

- a. Having access to and copying any records that must be kept under the conditions of the permit;
- b. Inspecting the facility, equipment, practices, or operations regulated or required under this permit; and
- c. Sampling or monitoring any substances or parameters at any location reasonably necessary to assure compliance with this permit or Department rules.

Reasonable time may depend on the nature of the concern being investigated.

8. If, for any reason, the permittee does not comply with or will be unable to comply with any condition or limitation specified in this permit, the permittee shall immediately notify and provide the Department with the following information:

- a. a description of and cause of non-compliance; and
- b. the period of noncompliance, including exact dates and times; or, if not corrected, the anticipated time the noncompliance is expected to continue, and steps being taken to reduce, eliminate, and prevent recurrence of the noncompliance.

PERMITTEE:  
Harris Semiconductor

Permit Number: AC 05-159484  
Expiration Date: April 30, 1990

**GENERAL CONDITIONS:**

The permittee shall be responsible for any and all damages which may result and may be subject to enforcement action by the Department for penalties or revocation of this permit.

9. In accepting this permit, the permittee understands and agrees that all records, notes, monitoring data and other information relating to the construction or operation of this permitted source, which are submitted to the Department, may be used by the Department as evidence in any enforcement case arising under the Florida Statutes or Department rules, except where such use is proscribed by Sections 403.73 and 403.111, Florida Statutes.

10. The permittee agrees to comply with changes in Department rules and Florida Statutes after a reasonable time for compliance, provided however, the permittee does not waive any other rights granted by Florida Statutes or Department rules.

11. This permit is transferable only upon Department approval in accordance with Florida Administrative Code Rules 17-4.12 and 17-30.30, as applicable. The permittee shall be liable for any noncompliance of the permitted activity until the transfer is approved by the Department.

12. This permit is required to be kept at the work site of the permitted activity during the entire period of construction or operation.

13. This permit also constitutes:

- ( ) Determination of Best Available Control Technology (BACT)
- ( ) Determination of Prevention of Significant Deterioration (PSD).
- ( ) Compliance with New Source Performance Standards.

14. The permittee shall comply with the following monitoring and record keeping requirements:

- a. Upon request, the permittee shall furnish all records and plans required under department rules. The retention period for all records will be extended automatically, unless otherwise stipulated by the Department, during the course of any unresolved enforcement action.



**PERMITTEE:**  
Harris Semiconductor

Permit Number: AC 05-159484  
Expiration Date: April 30, 1990

**GENERAL CONDITIONS:**

- b. The permittee shall retain at the facility or other location designated by this permit records of all monitoring information (including all calibration and maintenance records and all original strip chart recordings for continuous monitoring instrumentation), copies of all reports required by this permit, and records of all data used to complete the application for this permit. The time period of retention shall be at least three years from the date of the sample, measurement, report or application unless otherwise specified by Department rule.
- c. Records of monitoring information shall include:
- the date, exact place, and time of sampling or measurements;
  - the person responsible for performing the sampling or measurements;
  - the date(s) analyses were performed;
  - the person responsible for performing the analyses;
  - the analytical techniques or methods used; and
  - the results of such analyses.

15. When requested by the Department, the permittee shall within a reasonable time furnish any information required by law which is needed to determine compliance with the permit. If the permittee becomes aware that relevant facts were not submitted or were incorrect in the permit application or in any report to the Department, such facts or information shall be submitted or corrected promptly.

**SPECIFIC CONDITIONS:**

1. The maximum allowable VOC/solvent emissions from Building No. 58 shall be 3.2 tons per year.
2. The VOC/solvent vapor exhaust scrubber must be on during the working hours.
3. Annual operation shall be 8760 hours per year.
4. Objectionable odors shall not be allowed off plant property.

PERMITTEE:  
Harris Semiconductor

Permit Number: AC 05-159484  
Expiration Date: April 30, 1990

**SPECIFIC CONDITIONS:**

5. An inspection and maintenance plan shall be submitted to the DER's Central Florida District office as part of the operating permit application. The plan shall include provisions for the prevention and correction of VOC/solvent losses from leaks and equipment malfunctions.

6. By March 31 of each calendar year, an annual operating report shall be submitted to the DER's Central Florida District office demonstrating compliance with the VOC/solvent emissions limit for Building No. 58. The emissions shall be determined by a material balance scheme, verifiable on a monthly basis, and shall include the following:

- a) a beginning inventory of full containers, cylinders and storage tanks at the beginning of each calendar year;
- b) plus all purchased deliveries after the beginning inventory (verifiable by invoices);
- c) minus all quantities picked-up and shipped-off the premise after the beginning inventory (verifiable by invoices);
- d) minus all quantities deep well injected during the calendar year, justified by assumptions and established scrubber efficiencies; and,
- e) minus an ending inventory of full containers, cylinders, and storage tanks; and, should occur at the beginning of the following calendar year.

7. Each scrubber system's efficiency and potential VOC/solvent emissions shall be established by a sampling and analysis program, which includes:

- a) a sample shall be taken annually from each scrubber stack and analyzed using EPA Reference Method 25;
- b) the DER's Central Florida District office shall receive 15 days notice in writing prior to sampling; and,
- c) the report, summarizing the sampling results, shall be submitted to the DER's Central Florida District office within 45 days after the last test run is completed.

8. This permit will supercede all other permits previously issued on this source/Building No. 58.

9. The permittee, for good cause, may request that this construction permit be extended. Such a request shall be submitted to the BAQM prior to 60 days before the expiration of the permit (F.A.C. Rule 17-4.090).

10. An application for an operation permit must be submitted to the Central Florida District office at least 90 days prior to

PERMITEE:  
Harris Semiconductor

Permit Number: AC 05-159484  
Expiration Number: April 30, 1990

**SPECIFIC CONDITIONS:**

the expiration date of this construction permit or within 45 days after completion of compliance testing, whichever occurs first. To properly apply for an operation permit, the applicant shall submit the appropriate application form, fee, certification that construction was completed noting any deviations from the conditions in the construction permit, and compliance test reports as required by this permit (F.A.C. Rule 17-4.220).

11. Building No. 58 is subject to the provisions of F.A.C. Rules 17-2.240: Circumvention; 17-2.250: Excess Emissions; and, 17-4.130: Plant Operation - Problems.

12. Any modification pursuant to F.A.C. Rule 17-2.100(119), Modification, shall be submitted to the DER's Central Florida District office and the Bureau of Air Quality Management office for approval.

13. Projected potential acid emissions are 0.3 TPY.

14. The source/Building No. 58 is subject to all applicable provisions of F.A.C. Rules 17-2 and 17-4.

Issued this \_\_\_\_\_ day of \_\_\_\_\_,  
19\_\_\_\_.

**STATE OF FLORIDA DEPARTMENT  
OF ENVIRONMENTAL REGULATION**

\_\_\_\_\_  
Dale Twachtmann, Secretary

ATTACHMENT 1

Available Upon Request



1-13-89  
Palm Bay, FL

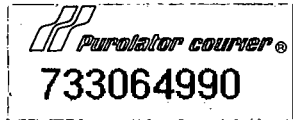

RECEIVED  
DER - MAIL ROOM  
1989 JAN 17 AM 10:02

FS-JRK-088-89

Mr. C. H. Fancy  
Deputy Bureau Chief  
Department of Environmental Regulations  
Bureau of Air Quality Management  
2600 Blair Stone Road  
Tallahassee, Florida 32301

REF: HARRIS SEMICONDUCTOR  
Building 58 Consolidated Air Permit

Dear Mr. Fancy:

On February 17, 1988 representatives from Harris and the Florida DER met in Orlando to discuss the status of air permits at Harris Semiconductor's facility in Palm Bay. At that meeting it was agreed that Harris would submit modified air permits. The purpose of the permit modifications was as follows:

1. Consolidate permits on a by building basis to reduce the existing number of permits.
2. To accurately quantify the current air emissions from the facility.

Enclosed is the original and two (2) copies of the modified permit applications for Semiconductor's Building 58. Also enclosed is a check in the amount of \$200.00 to cover the applicable permit fees.

If you should have any questions about the enclosed information, please feel free to contact me at (407) 724-7467.

Sincerely

J. R. Kolanek, Manager  
Environmental Services

/pgc

enclosures

cc: C. Collins, Central Florida District  
*B. Mitchell*

RECEIVED

JAN 17 1989

DER-BAQM

**Purolator courier**

Purolator Account No. to be billed: 53-94-27716 Date: 1/21/81

**733064990**

Service - Check One - See reverse side for detail:  
 Purolator Overnight Letter  
 Purolator Overnight Pack  
 Priority National Overnight Service Nationwide  
 Priority Regional Overnight Service  
 Standard 2-day Service  
 Saturday Delv. Extra Charge  
 Hold for Pick-up  
 Optional Service  
 Payment  Sender Prepaid  Third Party Cash/Check  Collect

From Sender's Name: R. KOLANEK Sender's Area Code/Phone Number: (407) 724-7467  
 To Recipient's Name: C. H. FANON Recipient's Area Code/Phone Number: (904) 488-0111

Company Name: MOORE'S SEMICONDUCTOR Company Name: F.D.E.R.  
 Dept./Suite: \_\_\_\_\_ Dept./Suite: \_\_\_\_\_

Street Address: DAWN BAY RD. BLDG Street Address (P.O. Box numbers not deliverable): 2600 BLAIR STONE ROAD

City: DAWN BAY State: FL Zip Code - Required: 32905  
 City: TALLAHASSEE State: FL Zip Code - Required: 32301

Sender's Signature: R. Kolanek P.O. or Reference Number: \_\_\_\_\_  
 Third Party Billing Name/Address: 16 59 007

Tariff	Rate Item	SM	Origin Airport	Destination Airport
				<u>364</u>

Advance	Valuation	Code	Amount	Code	Amount	Total Charge

Special Charge	DB	Route	Courier Guard Initial	S.S. Last 4' digits	PUROLATOR USE ONLY
	<input type="checkbox"/>			<u>5052</u>	



RECIPIENT'S COPY

01-000-S1353		HARRIS SEMICONDUCTOR			00049435	
VOUCHER NUMBER	INVOICE NUMBER	PURCHASE ORDER	INVOICE DATE	AMOUNT	DISCOUNT	NET AMOUNT
173426	120388		12-05-88	200.00	.00	200.00
T O T A L S				200.00	.00	200.00

REMITTANCE STATEMENT / DETACH BEFORE DEPOSITING

HARRIS SEMICONDUCTOR SECTOR

DEPARTMENT OF ENVIRONMENTAL REGULATION

#200.00 pd,  
1-17-89

AC 05-159484

WIN TOWERS OFFICE BUILDING  
2600 BLAIR STONE ROAD  
TALLAHASSEE, FLORIDA 32301-8241

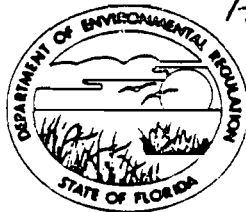

RECEIVED

BOB GRAHAM  
GOVERNOR  
VICTORIA J. TSCHINKEL  
SECRETARY

JAN 17 1989

APPLICATION TO OPERATE/CONSTRUCT AIR POLLUTION SOURCES  
DER - DAQM

SOURCE TYPE: Stationary [ ] New<sup>1</sup> [X] Existing<sup>1</sup>

APPLICATION TYPE: [ ] Construction [ ] Operation [X] Modification

COMPANY NAME: Harris Semiconductor COUNTY: Brevard

Identify the specific emission point source(s) addressed in this application (i.e. Lime  
Kiln No. 4 with Venturi Scrubber; Peaking Unit No. 2, Gas Fired) Building 58

SOURCE LOCATION: Street Palm Bay Road City Palm Bay

UTM: East 17-538700 North 17-3100900

Latitude 28 ° 01 ' 20 "N Longitude 80 ° 36 ' 10 "W

APPLICANT NAME AND TITLE: J. R. Kolanek; Manager Environmental Services

APPLICANT ADDRESS: P.O. Box 883, Melbourne, Fl 32901

SECTION I: STATEMENTS BY APPLICANT AND ENGINEER

A. APPLICANT

I am the undersigned owner or authorized representative\* of Harris Semiconductor

I certify that the statements made in this application for a modified permit are true, correct and complete to the best of my knowledge and belief. Further, I agree to maintain and operate the pollution control source and pollution control facilities in such a manner as to comply with the provision of Chapter 403, Florida Statutes, and all the rules and regulations of the department and revisions thereof. I also understand that a permit, if granted by the department, will be non-transferable and I will promptly notify the department upon sale or legal transfer of the permitted establishment.

\*Attach letter of authorization

Signed: J. R. Kolanek  
J. R. Kolanek, Manager, Environmental Svcs  
Name and Title (Please Type)

Date: 1/1/89 Telephone No. (407) 724-7467

B. PROFESSIONAL ENGINEER REGISTERED IN FLORIDA (where required by Chapter 471, F.S.)

This is to certify that the engineering features of this pollution control project have been designed/examined by me and found to be in conformity with modern engineering principles applicable to the treatment and disposal of pollutants characterized in the permit application. There is reasonable assurance, in my professional judgment, that

<sup>1</sup> See Florida Administrative Code Rule 17-2.100(57) and (104)



the pollution control facilities, when properly maintained and operated, will discharge an effluent that complies with all applicable statutes of the State of Florida and the rules and regulations of the department. It is also agreed that the undersigned will furnish, if authorized by the owner, the applicant a set of instructions for the proper maintenance and operation of the pollution control facilities and, if applicable, pollution sources.

Signed Lawrence R. Hutker

Lawrence R. Hutker

Name (Please Type)

Harris Semiconductor

Company Name (Please Type)

P.O. Box 883, Melbourne, Florida 32901

Mailing Address (Please Type)

Florida Registration No. 35972 Date: 1/1/89 Telephone No. (407) 729-4655

**SECTION II: GENERAL PROJECT INFORMATION**

1. Describe the nature and extent of the project. Refer to pollution control equipment, and expected improvements in source performance as a result of installation. State whether the project will result in full compliance. Attach additional sheet if necessary.

This is a modification and consolidation of existing air permits.

2. Schedule of project covered in this application (Construction Permit Application Only)

Start of Construction N/A Completion of Construction \_\_\_\_\_

3. Costs of pollution control system(s): (Note: Show breakdown of estimated costs only for individual components/units of the project serving pollution control purposes. Information on actual costs shall be furnished with the application for operation permit.)

N/A

4. Indicate any previous DER permits, orders and notices associated with the emission point, including permit issuance and expiration dates.

AC 05-104521 issued 1/15/86; expires 6/30/86  
AC 05-104527 issued 1/15/86; expires 4/01/86

E. Requested permitted equipment operating time: hrs/day 24 ; days/wk 7 ; wks/yr 52 ;  
if power plant, hrs/yr \_\_\_\_\_; if seasonal, describe: \_\_\_\_\_  
\_\_\_\_\_  
\_\_\_\_\_

F. If this is a new source or major modification, answer the following questions.  
(Yes or No)

1. Is this source in a non-attainment area for a particular pollutant? No  
a. If yes, has "offset" been applied? \_\_\_\_\_  
b. If yes, has "Lowest Achievable Emission Rate" been applied? \_\_\_\_\_  
c. If yes, list non-attainment pollutants. \_\_\_\_\_

2. Does best available control technology (BACT) apply to this source?  
If yes, see Section VI. No

3. Does the State "Prevention of Significant Deterioration" (PSD)  
requirement apply to this source? If yes, see Sections VI and VII. No

4. Do "Standards of Performance for New Stationary Sources" (NSPS)  
apply to this source? No

5. Do "National Emission Standards for Hazardous Air Pollutants"  
(NESHAP) apply to this source? No

H. Do "Reasonably Available Control Technology" (RACT) requirements apply  
to this source? No

a. If yes, for what pollutants? \_\_\_\_\_

b. If yes, in addition to the information required in this form,  
any information requested in Rule 17-2.650 must be submitted.

Attach all supportive information related to any answer of "Yes". Attach any justifi-  
cation for any answer of "No" that might be considered questionable.

SECTION III: AIR POLLUTION SOURCES & CONTROL DEVICES (Other than Incinerators)

A. Raw Materials and Chemicals Used in your Process, if applicable:

Description	Contaminants		Utilization Rate - lbs/hr	Relate to Flow Diagram
	Type	% Wt		
---SEE ATTACHMENT C ---				

B. Process Rate, if applicable: (See Section V, Item 1)

1. Total Process Input Rate (lbs/hr): not applicable

2. Product Weight (lbs/hr): not applicable

C. Airborne Contaminants Emitted: (Information in this table must be submitted for each emission point, use additional sheets as necessary)

Name of Contaminant	Emission <sup>1</sup>		Allowed Emission Rate per Rule 17-2	Allowable <sup>3</sup> Emission lbs/hr	Potential <sup>4</sup> Emission		Relate to Flow Diagram
	Maximum lbs/hr	Actual T/yr			lbs/yr	T/yr	
---SEE ATTACHMENT B ---							

<sup>1</sup>See Section V, Item 2.

<sup>2</sup>Reference applicable emission standards and units (e.g. Rule 17-2.600(5)(b)2. Table II, E. (1) - 0.1 pounds per million BTU heat input)

<sup>3</sup>Calculated from operating rate and applicable standard.

<sup>4</sup>Emission, if source operated without control (See Section V, Item 3).

J. Control Devices: (See Section V, Item 4)

Name and Type (Model & Serial No.)	Contaminant	Efficiency	Range of Particles Size Collected (in microns) (If applicable)	Basis for Efficiency (Section V Item 5)
---SEE ATTACHMENT D ---				

E. Fuels

Type (Be Specific)	Consumption*		Maximum Heat Input (MMBTU/hr)
	avg/hr	max./hr	

\*Units: Natural Gas--MMCF/hr; Fuel Oils--gallons/hr; Coal, wood, refuse, other--lbs/hr.

Fuel Analysis:

Percent Sulfur: \_\_\_\_\_ Percent Ash: \_\_\_\_\_

Density: \_\_\_\_\_ lbs/gal Typical Percent Nitrogen: \_\_\_\_\_

Heat Capacity: \_\_\_\_\_ BTU/lb \_\_\_\_\_ BTU/gal

Other Fuel Contaminants (which may cause air pollution): \_\_\_\_\_

F. If applicable, indicate the percent of fuel used for space heating.

Annual Average \_\_\_\_\_ Maximum \_\_\_\_\_

G. Indicate liquid or solid wastes generated and method of disposal.

Waste water from air scrubbers is discharged to on-site Waste Water Treatment

Plant--discharge to deepwell under UIC - Permit #UC05-126519.

-----SEE ATTACHMENT D-----

H. Emission Stack Geometry and Flow Characteristics (Provide data for each stack):

Stack Height: \_\_\_\_\_ ft. Stack Diameter: \_\_\_\_\_ ft.  
 Gas Flow Rate: \_\_\_\_\_ ACFM \_\_\_\_\_ DSCFM Gas Exit Temperature: \_\_\_\_\_ °F.  
 Water Vapor Content: \_\_\_\_\_ % Velocity: \_\_\_\_\_ FPS

SECTION IV: INCINERATOR INFORMATION

not applicable

Type of Waste	Type 0 (Plastics)	Type I (Rubbish)	Type II (Refuse)	Type III (Garbage)	Type IV (Pathological)	Type V (Liq. & Gas By-prod.)	Type VI (Solid By-prod.)
Actual lb/hr Incinerated							
Uncontrolled (lbs/hr)							

Description of Waste \_\_\_\_\_  
 Total Weight Incinerated (lbs/hr) \_\_\_\_\_ Design Capacity (lbs/hr) \_\_\_\_\_  
 Approximate Number of Hours of Operation per day \_\_\_\_\_ day/wk \_\_\_\_\_ wks/yr. \_\_\_\_\_  
 Manufacturer \_\_\_\_\_  
 Date Constructed \_\_\_\_\_ Model No. \_\_\_\_\_

	Volume (ft) <sup>3</sup>	Heat Release (BTU/hr)	Fuel		Temperature (°F)
			Type	BTU/hr	
Primary Chamber					
Secondary Chamber					

Stack Height: \_\_\_\_\_ ft. Stack Diameter: \_\_\_\_\_ Stack Temp. \_\_\_\_\_  
 Gas Flow Rate: \_\_\_\_\_ ACFM \_\_\_\_\_ DSCFM\* Velocity: \_\_\_\_\_ FPS

\*If 50 or more tons per day design capacity, submit the emissions rate in grains per standard cubic foot dry gas corrected to 50% excess air.

Type of pollution control device:  Cyclone  Wet Scrubber  Afterburner  
 Other (specify) \_\_\_\_\_

Brief description of operating characteristics of control devices: \_\_\_\_\_

\_\_\_\_\_  
\_\_\_\_\_  
\_\_\_\_\_

Ultimate disposal of any effluent other than that emitted from the stack (scrubber water, ash, etc.):

\_\_\_\_\_  
\_\_\_\_\_  
\_\_\_\_\_

NOTE: Items 2, 3, 4, 6, 7, 8, and 10 in Section V must be included where applicable.

**SECTION V: SUPPLEMENTAL REQUIREMENTS**

Please provide the following supplements where required for this application.

1. Total process input rate and product weight -- show derivation [Rule 17-2.100(127)]
2. To a construction application, attach basis of emission estimate (e.g., design calculations, design drawings, pertinent manufacturer's test data, etc.) and attach proposed methods (e.g., FR Part 60 Methods 1, 2, 3, 4, 5) to show proof of compliance with applicable standards. To an operation application, attach test results or methods used to show proof of compliance. Information provided when applying for an operation permit from a construction permit shall be indicative of the time at which the test was made.
3. Attach basis of potential discharge (e.g., emission factor, that is, AP42 test).
4. With construction permit application, include design details for all air pollution control systems (e.g., for baghouse include cloth to air ratio; for scrubber include cross-section sketch, design pressure drop, etc.)
5. With construction permit application, attach derivation of control device(s) efficiency. Include test or design data. Items 2, 3 and 5 should be consistent: actual emissions = potential (1-efficiency).
6. An 8 1/2" x 11" flow diagram which will, without revealing trade secrets, identify the individual operations and/or processes. Indicate where raw materials enter, where solid and liquid waste exit, where gaseous emissions and/or airborne particles are evolved and where finished products are obtained.
7. An 8 1/2" x 11" plot plan showing the location of the establishment, and points of airborne emissions, in relation to the surrounding area, residences and other permanent structures and roadways (Example: Copy of relevant portion of USGS topographic map).
8. An 8 1/2" x 11" plot plan of facility showing the location of manufacturing processes and outlets for airborne emissions. Relate all flows to the flow diagram.

9. The appropriate application fee in accordance with Rule 17-4.05. The check should be made payable to the Department of Environmental Regulation.
10. With an application for operation permit, attach a Certificate of Completion of Construction indicating that the source was constructed as shown in the construction permit.

**SECTION VI: BEST AVAILABLE CONTROL TECHNOLOGY**

A. Are standards of performance for new stationary sources pursuant to 40 C.F.R. Part 60 applicable to the source?

Yes  No

Contaminant	Rate or Concentration

B. Has EPA declared the best available control technology for this class of sources (if yes, attach copy)

Yes  No

Contaminant	Rate or Concentration

C. What emission levels do you propose as best available control technology?

Contaminant	Rate or Concentration

D. Describe the existing control and treatment technology (if any).

- |                           |                          |
|---------------------------|--------------------------|
| 1. Control Device/System: | 2. Operating Principles: |
| 3. Efficiency:*           | 4. Capital Costs:        |

\*Explain method of determining

5. Useful Life:

6. Operating Costs:

7. Energy:

8. Maintenance Cost:

9. Emissions:

Contaminant

Rate or Concentration

Contaminant	Rate or Concentration

10. Stack Parameters

a. Height:

ft.

b. Diameter:

ft.

c. Flow Rate:

ACFM

d. Temperature:

°F.

e. Velocity:

FPS

E. Describe the control and treatment technology available (As many types as applicable, use additional pages if necessary).

1.

a. Control Device:

b. Operating Principles:

c. Efficiency:<sup>1</sup>

d. Capital Cost:

e. Useful Life:

f. Operating Cost:

g. Energy:<sup>2</sup>

h. Maintenance Cost:

i. Availability of construction materials and process chemicals:

j. Applicability to manufacturing processes:

k. Ability to construct with control device, install in available space, and operate within proposed levels:

2.

a. Control Device:

b. Operating Principles:

c. Efficiency:<sup>1</sup>

d. Capital Cost:

e. Useful Life:

f. Operating Cost:

g. Energy:<sup>2</sup>

h. Maintenance Cost:

i. Availability of construction materials and process chemicals:

<sup>1</sup>Explain method of determining efficiency.

<sup>2</sup>Energy to be reported in units of electrical power - KWH design rate.



- j. Applicability to manufacturing processes:
- k. Ability to construct with control device, install in available space, and operate within proposed levels:

3.

- a. Control Device:
- b. Operating Principles:
- c. Efficiency:<sup>1</sup>
- d. Capital Cost:
- e. Useful Life:
- f. Operating Cost:
- g. Energy:<sup>2</sup>
- h. Maintenance Cost:
- i. Availability of construction materials and process chemicals:
- j. Applicability to manufacturing processes:
- k. Ability to construct with control device, install in available space, and operate within proposed levels:

4.

- a. Control Device:
- b. Operating Principles:
- c. Efficiency:<sup>1</sup>
- d. Capital Costs:
- e. Useful Life:
- f. Operating Cost:
- g. Energy:<sup>2</sup>
- h. Maintenance Cost:
- i. Availability of construction materials and process chemicals:
- j. Applicability to manufacturing processes:
- k. Ability to construct with control device, install in available space, and operate within proposed levels:

F. Describe the control technology selected:

- 1. Control Device:
- 2. Efficiency:<sup>1</sup>
- 3. Capital Cost:
- 4. Useful Life:
- 5. Operating Cost:
- 6. Energy:<sup>2</sup>
- 7. Maintenance Cost:
- 8. Manufacturer:
- 9. Other locations where employed on similar processes:
  - a. (1) Company:
  - (2) Mailing Address:
  - (3) City:
  - (4) State:

Explain method of determining efficiency.  
 Energy to be reported in units of electrical power - KWH design rate.

- (5) Environmental Manager:
- (6) Telephone No.:
- (7) Emissions:<sup>1</sup>

Contaminant	Rate or Concentration

- (8) Process Rate:<sup>1</sup>
- b. (1) Company:
- (2) Mailing Address:
- (3) City: (4) State:
- (5) Environmental Manager:
- (6) Telephone No.:
- (7) Emissions:<sup>1</sup>

Contaminant	Rate or Concentration

- (8) Process Rate:<sup>1</sup>
- 10. Reason for selection and description of systems:

<sup>1</sup>Applicant must provide this information when available. Should this information not be available, applicant must state the reason(s) why.

**SECTION VII - PREVENTION OF SIGNIFICANT DETERIORATION**

**A. Company Monitored Data**

1. \_\_\_\_\_ no. sites \_\_\_\_\_ TSP ( ) SO<sub>2</sub> \_\_\_\_\_ Wind spd/dir  
 Period of Monitoring \_\_\_\_\_ / \_\_\_\_\_ / \_\_\_\_\_ to \_\_\_\_\_ / \_\_\_\_\_ / \_\_\_\_\_  
month day year month day year

Other data recorded \_\_\_\_\_

Attach all data or statistical summaries to this application.

Specify bubbler (B) or continuous (C).

2. Instrumentation, Field and Laboratory

- a. Was instrumentation EPA referenced or its equivalent?  Yes  No
- b. Was instrumentation calibrated in accordance with Department procedures?  
 Yes  No  Unknown

B. Meteorological Data Used for Air Quality Modeling

1. \_\_\_\_\_ Year(s) of data from \_\_\_\_\_ / \_\_\_\_\_ / \_\_\_\_\_ to \_\_\_\_\_ / \_\_\_\_\_ / \_\_\_\_\_  
month day year month day year
2. Surface data obtained from (location) \_\_\_\_\_
3. Upper air (mixing height) data obtained from (location) \_\_\_\_\_
4. Stability wind rose (STAR) data obtained from (location) \_\_\_\_\_

C. Computer Models Used

1. \_\_\_\_\_ Modified? If yes, attach description.
2. \_\_\_\_\_ Modified? If yes, attach description.
3. \_\_\_\_\_ Modified? If yes, attach description.
4. \_\_\_\_\_ Modified? If yes, attach description.

Attach copies of all final model runs showing input data, receptor locations, and principle output tables.

D. Applicants Maximum Allowable Emission Data

Pollutant	Emission Rate
TSP	_____ grams/sec
SO <sub>2</sub>	_____ grams/sec

E. Emission Data Used in Modeling

Attach list of emission sources. Emission data required is source name, description of point source (on NEDS point number), UTM coordinates, stack data, allowable emissions, and normal operating time.

F. Attach all other information supportive to the PSD review.

G. Discuss the social and economic impact of the selected technology versus other applicable technologies (i.e., jobs, payroll, production, taxes, energy, etc.). Include assessment of the environmental impact of the sources.

H. Attach scientific, engineering, and technical material, reports, publications, journals, and other competent relevant information describing the theory and application of the requested best available control technology.

*HARRIS SEMICONDUCTOR*  
*AIR PERMIT - BUILDING 58*  
*ATTACHMENT A*  
*PROCESS DESCRIPTION*

## ATTACHMENT A

The primary manufacturing operations in building 58 are assembly and testing of integrated circuits. In the Assembly and Test areas, a series of processing and quality control steps are incorporated to produce the final product. Wafers are cut (or 'diced') into the individual units (or die) they are comprised of. The die are then put into circuit packages and the wires are ultrasonically bonded. The resulting integrated circuits are tested for a wide variety of parameters including tolerance to temperature and humidity changes, endurance, and electrical conductivity. Exhausted equipment includes saws, soldering stations, degreasers, die wash units, bake ovens, fine leak test systems, compressors, furnaces, chemical cabinets, and wet stations dedicated to the cleaning of product parts.

In addition, the two-story building houses a Brand area, a P.C. board Technology Lab, and a Product Development Lab.

In the Brand area, product information is stamped onto the integrated circuit packages. Exhausted equipment includes wet stations, branders, and chemical storage cabinets.

The P.C. board Technology and Product Development Labs manufacture printed circuit boards. Examples of equipment attached to the exhaust system are coaters, ovens, etchers, and wet stations. Defective products are tested in the Reliability Lab. Etchers and wet stations are exhausted.

Scrubber number F58S01 treats caustic and corrosive contaminated exhaust from Assembly, Test, Brand, and Reliability Lab areas. Scrubber number F58S02 addresses solvent contaminated air streams from the Analog Product Development Lab. Exhaust fan F58E01 provides exhaust for equipment in Assembly, Test, Brand, and P.C. Board Technology Labs. The scrubbers are located on the roof, and the fan is mounted on the west side of the building at ground level (see attached location maps.)

In a room located on the east side of the building, an automatic abrading machine is used to remove stamped-on labels from semiconductors. The exhaust generated from the process is contaminated with alumina powder. A Torit model TD 486 dust collector is employed to capture the dust. The dust collector resides on the exterior wall of the building. (See process flow diagram and system description in attachments.)

The assembly area houses a fine leak system that utilizes Krypton 85 gas to pressurize electronic components and to detect faulty hermetic seals in circuits. The system has its own exhaust fan, and is permitted under a radioactive materials license by the State of Florida Department of Health and Rehabilitative Services Office of Radiation Control (license number 662-3.)

*HARRIS SEMICONDUCTOR*  
*AIR PERMIT - BUILDING 58*  
*ATTACHMENT B*  
*AIR EMISSIONS*

## SOLVENT MONITORING--BUILDING 58

Solvent monitoring work was performed on the building 58 scrubber systems F58S01 and F58S02 during December of 1986. The test conducted was EPA Method 25A (flame ionization detection.) The results of the testing is included in this application.

FID test results revealed that total accumulative monitored VOC emissions for the building were 3.24 tons/year expressed as propane. This figure is based on a hypothetical production schedule of 8760 hours a year. The following assumptions were made regarding monitoring work on this building:

-VOC values refer to all organic emissions including organic solvents.

-All data was corrected for 2 ppm background noise that is normally present in the ambient air.

-The F.I.D. accumulative emission figure is based on the maximum concentration of VOC's observed during the monitoring time frame.

EPA METHOD 25-A (F.I.D. ANALYSIS) BUILDING 58  
VOC EMISSIONS DURING FULL PRODUCTION

TEST DATE	SCRUBBER #	PRODUCTN SCHEDULE (HRS/YR)	VOC EMISSIONS (TON/YR)
12/17/86	F58S01	8760	2.82
12/18/86	F58S02	8760	0.42

TOTAL PROJECTED VOC EMISSIONS FOR BLDG 58 = 3.24 TONS/YEAR



## ACID MONITORING--BUILDING 58

Acid monitoring was performed on scrubber F58S01 in August of 1988. Samples were collected using modified EPA method 8 sampling train. The impinger medium consisted of a 0.1 N sodium hydroxide solution. The analytical methodology utilized to determine the ions of highest concentration is as follows:

Chloride ion--EPA Method 325.3

Fluoride ion--EPA Method 340.2

Nitrate, phosphite, and sulfate ions--ion chromatography

All results were in pounds per hour as "X", where "X" represents the acid compound present in highest concentration.

The test results revealed that the total accumulative monitored acid emissions for the building were 0.2803 tons/year expressed as hydrochloric, hydrofluoric, nitric, phosphoric and sulfuric acids. This figure is based on a hypothetical production schedule of 8760 hours a year. The monitoring was performed over an 8 hour time interval when the full production was occurring.

When a resulting acid concentration was expressed as a "less than 'y' " value, where 'y' represents the lowest detectable limit possible using the analytical methodology employed, acid emissions were taken to be equal to this 'y' limit value.

RESULTS OF ACID MONITORING--BUILDING 58  
 PERFORMED IN AUGUST OF 1988  
 BASED ON FULL PRODUCTION

Scrubber #	HCl	HF	Nitric Acid	Phos-phoric Acid	Sulfuric Acid	TOTAL (TON/YR)
F58S01 outlet (lb/hr)	0.0530	0.0010	0.0020	0.0020	0.0060	
(ton/yr)	0.2321	0.0044	0.0088	0.0088	0.0263	0.2803

TOTAL ACID EMISSIONS INTO SCRUBBER OUTLET = 0.2803 TONS/YEAR

*HARRIS SEMICONDUCTOR*  
*AIR PERMIT - BUILDING 58*  
*ATTACHMENT C*  
*RAW MATERIALS AND CHEMICALS*

BUILDING 58 CONSOLIDATED AIR PERMIT  
PROCESS SOLVENTS

1,1,1 TRIMETHYL-N-TRIMETHYL ETHER  
1-METHOXY-2-PROPANOL ACETATE  
2-BUTOXYETHANOL  
2-METHYL-4-ISOTHIAZOLIN-3-ONE  
4-METHYL-2,4-PENAHNEDIOL  
5-CHLORO-2-METHYL-4  
ACETONE  
ALIPHATIC SOLVENTS  
ALIPHATIC PETROLEUM DISTILLATES  
ALKYL AMINE  
AROMATIC BISAZIDE  
BARIUM HYDROXIDE  
BUTYL CELLOSOLVE  
CELLOSOLVE ACETATE  
CHLORODIFLUOROMETHANE  
CHLOROPENTAFLUOROETHANE  
CHLOROTRIFLUOROMETHANE  
CYCLIZED POLYISOPRENE  
DICHLORODIFLUOROMETHANE  
ETHANOLAMINE  
ETHYL ALCOHOL  
ETHYLBENZENE  
ETHYLENE DIAMINE  
ETHYLENE KX 400000  
HYDROXYETHYL ALKYL IMIDAZOLINE  
INERT FLUORO-CHEMICAL FC-40  
INERT FLUORO-CHEMICAL FC-43  
INERT FLUORO-CHEMICAL FC-48  
INERT FLUORO-CHEMICAL FC-70  
INERT FLUORO-CHEMICAL FC-71  
INERT FLUORO-CHEMICAL FC-72  
INERT FLUORO-CHEMICAL FC-75  
INERT FLUORO-CHEMICAL FC-77  
INERT FLUORO-CHEMICAL FC-78  
INERT FLUORO-CHEMICAL FC-84  
GLYCERINE  
HYDROCARBON PROPELLANT  
ISOBUTANE PROPELLANT  
ISOPARRAFFINIC HYDROCARBONS  
ISOPROPYL ALCOHOL  
KEROSENE  
LAKTANE  
METHANOL  
METHOXYSILANE  
METHYL ETHYL KETONE  
METHYL TRIMETHOXYSILANE  
METHYLENE CHLORIDE  
MINERAL SPIRITS  
MONOETHANOLAMINE  
N,N-DIMETHYL FORMAMIDE  
NITROMETHANE  
(CONTINUED)

BUILDING 58 CONSOLIDATED AIR PERMIT  
PROCESS SOLVENTS (CONT.)

N-BUTYL ACETATE  
ORGANIC ACID  
ORGANIC SALTS  
OXYLPHENOL POLYETHOXYLATE  
PETROLATUM  
PHENOL  
POLYALKYLENE GLYCOL  
POLYETHYLENE GLYCOL  
POTASSIUM HYDROXIDE  
PROPYLENE GLYCOL METHYL ETHER ACETATE  
STODDARD SOLVENT  
TELOMER OF TETRAFLUOROETHANE  
TELOMER OF TETRAFLUOROETHYLENE  
TERTIARY AMINE SOLVENT  
TETRAFLUOROMETHANE  
TOLUENE  
TRICHLOROETHANE  
TRICHLOROETHYLENE  
TRICHLOROFUOROETHANE  
TRICHLOROFUOROMETHANE  
TRICHLOROTRIFLUOROETHANE  
TRICHLOROTRIFLUOROMETHANE  
TRIETHYLENE GLYCOL MONOMETHYL ETHER  
TURPENTINE  
XYLENE

BUILDING 58 CONSOLIDATED AIR PERMIT  
PROCESS CHEMICALS ❖

2,6-DI-TERT-BUTYL-P-CRESOL  
ACETIC ACID  
ACRYLIC POLYMER  
ALIPHATIC PETROLEUM DISTILLATES  
ALKANOLMINE  
ALUMINA POWDER  
AMINE SALT  
AMINO ACID CHLORIDE  
AMMONIA  
AMMONIUM CHLORIDE  
AMMONIUM FLUORIDE  
AMMONIUM OXALATE  
ARGON  
BENZOIC ACID  
BORIC ACID  
CALCIUM CARBONATE  
CALCIUM CHLORIDE  
CALCIUM HYDROXIDE  
CALCIUM HYPOCHLORITE  
CARAMIDE  
CARBON  
CARBON DISULFIDE  
CARBOXYLIC ACID  
CERIC SULFATE  
CORROSION INHIBITOR  
CRESOL  
CUPRIC NITRATE  
CUPRIC SULFATE  
DIAMOND POWDER  
DIATOMACEOUS EARTH  
EPOXY RESIN  
ETHOXYLATED TALL OIL FATTY ACIDS  
FATTY ACIDS  
FORMIC ACID  
FUEL OIL #2  
GLUTAMATE POLYMER ACTIVATOR  
GLUTAMATE POLYMER HYDROCHLORIDE  
GLYCERINE  
GUM RESIN  
HEAVY AROMATIC NAPHTHA  
HYDROCARBON PROPELLANT  
HYDROCHLORIC ACID  
HYDROFLUORIC ACID  
IODENE COMPLEX  
ISOBUTANE PROPELLANT  
ISOPARAFFINIC HYDROCARBONS  
LAKTANE  
LEAD  
LEAD NITRATE  
LEAD OXIDE  
MODIFIED N-ALKYL DIMETHYL AMMONIUM SALTS  
(CONTINUED)

BUILDING 58 CONSOLIDATED AIR PERMIT  
PROCESS CHEMICALS (CONT.)

MOLYBDENUM DISULFIDE  
NAPHTHENIC OIL  
NITRIC ACID  
NITROGEN  
N-ALKYL DIMETHYL BENZYL AMMONIUM SALTS  
N-ALKYL DIMETHYL ETHYLBENZYL AMMONIUM SALTS  
ORGANIC SALTS  
PARAFFINIC GREASE  
PETROLEUM OIL  
PHOSPHORIC ACID  
PINENE RESIN  
POLYALKYLENE GLYCOL  
POLYFUNCTIONAL ACID  
POTASSIUM BIFLUORIDE  
POTASSIUM CYANIDE  
POTASSIUM NITRATE  
POTASSIUM PENTABORATE  
POTASSIUM SOAP  
POTASSIUM TETRABORATE  
ROSIN  
SILANAMINE  
SILICONE  
SILVER  
SILVER CHLORIDE  
SODIUM CARBONATE  
SODIUM CHLORIDE  
SODIUM DICHROMATE  
SODIUM DODECYLSULFATE  
SODIUM HYPOCHLORITE  
SODIUM NITRATE  
SODIUM PERSULFATE  
STANNOUS SULFATE  
STEARIC ACID  
SULFURIC ACID  
TERPENE RESIN  
THIOUREA  
TIN  
WHITE OIL  
ZINC CHLORIDE  
ZINC DIALKYLDITHIOPHOSPHATE

BUILDING 58 CONSOLIDATED AIR PERMIT  
PROCESS GASES

ACETYLENE  
AMMONIA  
ARGON  
CARBON DIOXIDE & PROPELLANT  
HELIUM  
HYDROGEN  
KRYPTON 85  
NITROGEN  
OXYGEN  
PROPANE



*HARRIS SEMICONDUCTOR*  
*AIR PERMIT - BUILDING 58*  
*ATTACHMENT D*  
*CONTROL EQUIPMENT*

# The Tri-Mer Fume Washer

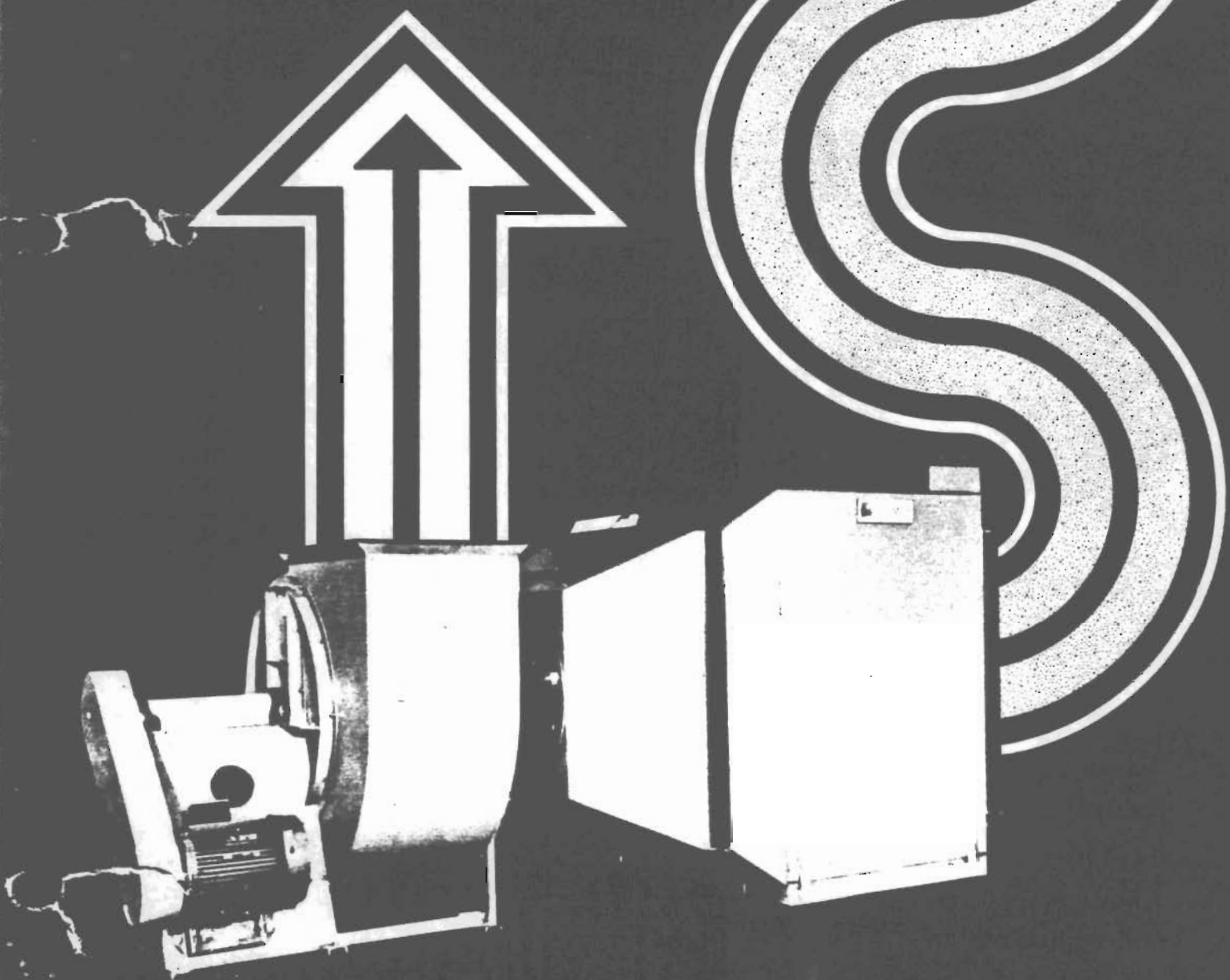

Designers and Manufacturers of Corrosion Control Systems

# Design Features of the Tri-Mer Fume Washer

TRI-MER fume washers offer an efficient economically packaged solution to your corrosive fume problems. Couple this unit to a TRI-MER all PVC fan, or use your existing fan, and you're ready for operation. A simple inexpensive installation.

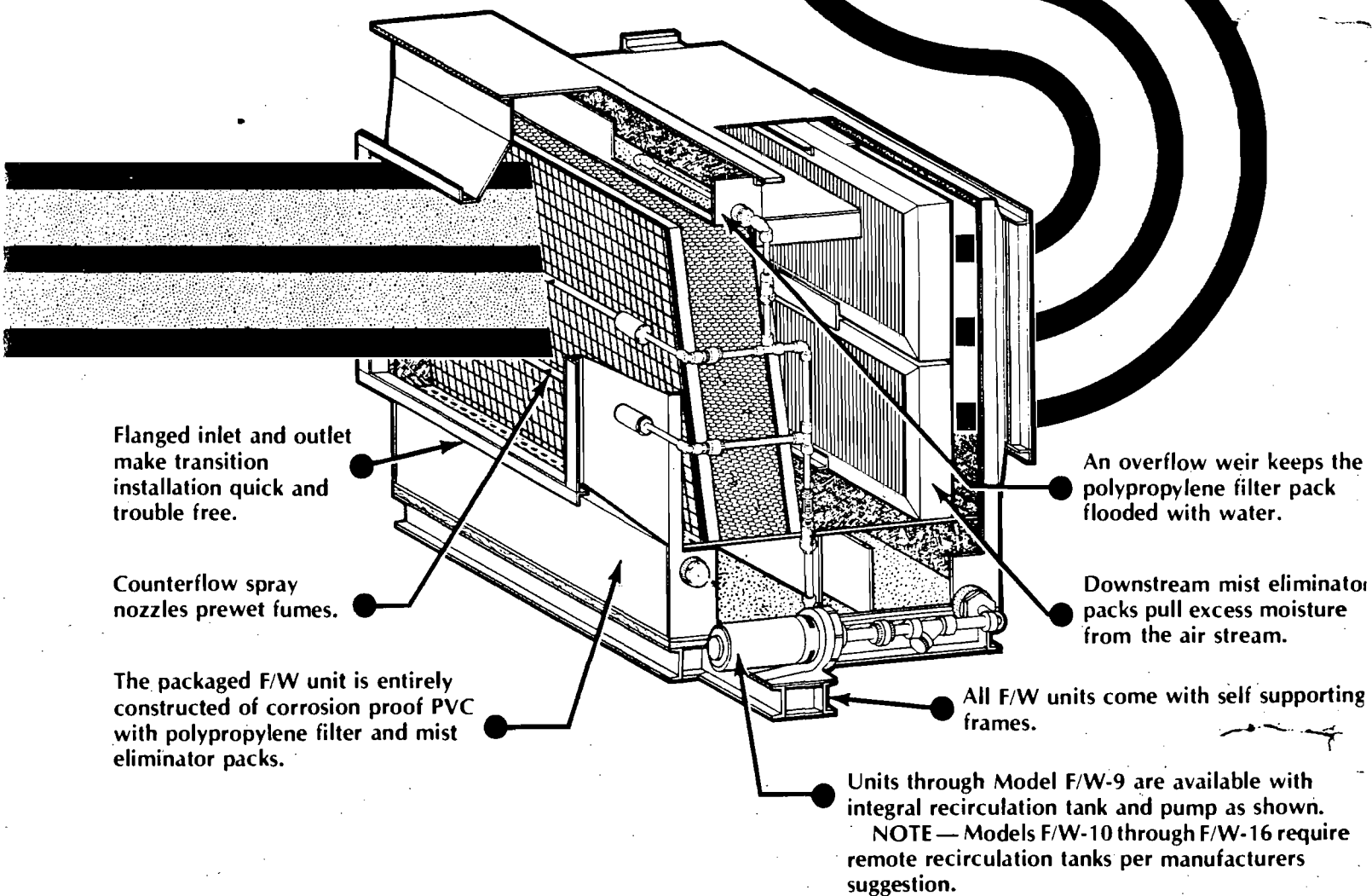

FW with integral recirculation tank. FW without integral recirculation tank.

FW	A	B	C	D	E	F	G	H	J	K	L	M	R	CHANNEL	ANGLE	DRAIN	G.P.M.	No. OF HEADERS	PIPE	CFM CAPACITY			
1	3'-11 1/2"	4'-4 1/2"	3'-6"	4'-3"	5'-3"	3'-4"	3'-4"	4'-10"	6"	6"	28"	28"	1'-8"	2'-0 1/4"	3'-0 1/4"	8"	4"@5.4#	1 1/2"x1 1/2"x3/16"	3"	8	2	3/4"	3,000 to 5,500
2	4'-3 1/2"	4'-8 1/2"	3'-10"	4'-6 1/4"	5'-6 1/4"	3'-8"	3'-4"	5'-2"	4 1/2"	4 1/2"	35"	35"	1'-10"	2'-2 1/4"	3'-2 1/4"	8"	4"@5.4#	1 1/2"x1 1/2"x3/16"	3"	9	2	3/4"	5,500 to 7,000
3	5'-0 1/2"	5'-5 1/2"	3'-6"	5'-3 1/4"	6'-3 1/4"	4'-5"	4'-5"	4'-10"	8"	8"	37"	37"	2'-4 1/2"	2'-7 1/4"	3'-7 1/4"	8"	4"@5.4#	1 1/2"x1 1/2"x3/16"	3"	12	2	3/4"	7,000 to 9,500
4	5'-6"	5'-11"	4'-0"	5'-8 1/4"	6'-8 1/4"	4'-10"	4'-10"	5'-6"	6 1/2"	6 1/2"	45"	45"	2'-5"	2'-9 1/4"	3'-9 1/4"	9"	4"@5.4#	2"x2"x1/4"	3"	14	2	3/4"	9,500 to 11,800
5	6'-0"	6'-5"	3'-8 1/2"	6'-2 1/4"	7'-2 1/4"	5 1/4"	5'-4"	5'-2 1/4"	9 1/2"	9 1/2"	45"	45"	2'-8"	3'-0 1/4"	4'-0 1/4"	9"	4"@5.4#	2"x2"x1/4"	3"	16	2	3/4"	11,500 to 14,000
6	6'-8"	7'-1"	4'-1 1/2"	6'-10 1/4"	7'-10 1/4"	6'-0"	6'-0"	6'-1 1/2"	11"	11"	50"	50"	3'-0"	3'-4 1/4"	4'-4 1/4"	1'-0"	4"@5.4#	2"x2"x1/4"	3"	19	2	3/4"	14,000 to 17,000
7	6'-11"	7'-5"	3'-10 1/4"	7'-3"	8'-3"	6'-4"	6'-4"	5'-10 1/4"	11"	11"	54"	54"	3'-2"	3'-6 1/4"	4'-6 1/4"	1'-0"	4"@5.4#	2"x2"x1/4"	3"	22	2	3/4"	17,000 to 20,000
8	7'-8"	8'-1"	4'-3"	7'-10 1/4"	8'-10 1/4"	7'-0"	7'-0"	6'-3"	1'-0 1/2"	1'-0 1/2"	59"	59"	3'-6"	3'-9 1/4"	3'-9 1/4"	1'-0"	4"@5.4#	2"x2"x1/4"	3"	28	2	3/4"	20,000 to 24,000
9	8'-5"	9'-0"	4'-0 1/4"	8'-8"	9'-8"	7'-9"	7'-9"	6'-0 1/4"	1'-1 1/2"	1'-1 1/2"	66"	66"	3'-10 1/2"	4'-2 1/4"	5'-2 1/4"	1'-0"	4"@5.4#	2"x2"x1/4"	3"	34	3	3/4"	24,000 to 30,000
10	9'-7"		4'-5"	9'-11 1/4"	8'-11"	8'-11"	6'-5"	1'-3 1/2"	1'-3 1/2"	76"	76"	4'-5 1/2"	5'-0 1/4"		1'-0"	6"@8.2#	2"x2"x1/4"	3"	44	3	1"	30,000 to 40,000	
11	12'-1"		4'-2 1/2"	9'-9 1/4"	8'-9"	8'-9"	11'-5"	6'-2 1/2"	10"	2'-2"	85"	85"	5'-8"	4'-11 1/4"		1'-0"	6"@8.2#	2"x2"x1/4"	3"	56	3	1"	40,000 to 50,000
12	14'-5"		4'-5 1/2"	9'-9 1/4"	8'-9"	13'-9"	8'-5 1/2"	10"	2'-7 1/2"	85"	102"	6'-10 1/2"	4'-11 1/4"	2'-0"	6"@8.2#	2"x2"x1/4"	3"	66	3	1"	50,000 to 60,000		
14	17'-9"		4'-5 1/2"	9'-9 1/4"	8'-9"	17'-1"	8'-5 1/2"	10"	3'-2 1/2"	85"	128"	8'-5 1/2"	4'-11 1/4"	2'-0"	6"@8.2#	2"x2"x1/4"	3"	81	3	1"	60,000 to 75,000		
15	20'-8"		4'-2 1/2"	9'-9 1/4"	8'-9"	19'-10"	8'-2 1/2"	10"	3'-9 1/2"	85"	147"	9'-11"	4'-11 1/4"	2'-0"	6"@8.2#	2"x2"x1/4"	3"	93	3	1 1/2"	75,000 to 87,000		
16	20'-8"		4'-7"	11'-0 1/4"	10'-0"	20'-0"	8'-7"	1'-5 1/2"	3'-0"	85"	240"	10'-0"	5'-6 1/4"	2'-0"	6"@8.2#	2"x2"x1/4"	3"	106	3	1 1/2"	87,000 to 100,000		

\* NOTE — For exact unit weight check with manufacturers.

\* NOTE — Double pack models are available where particularly heavy loadings exist. Check with manufacturer for dimensional changes.

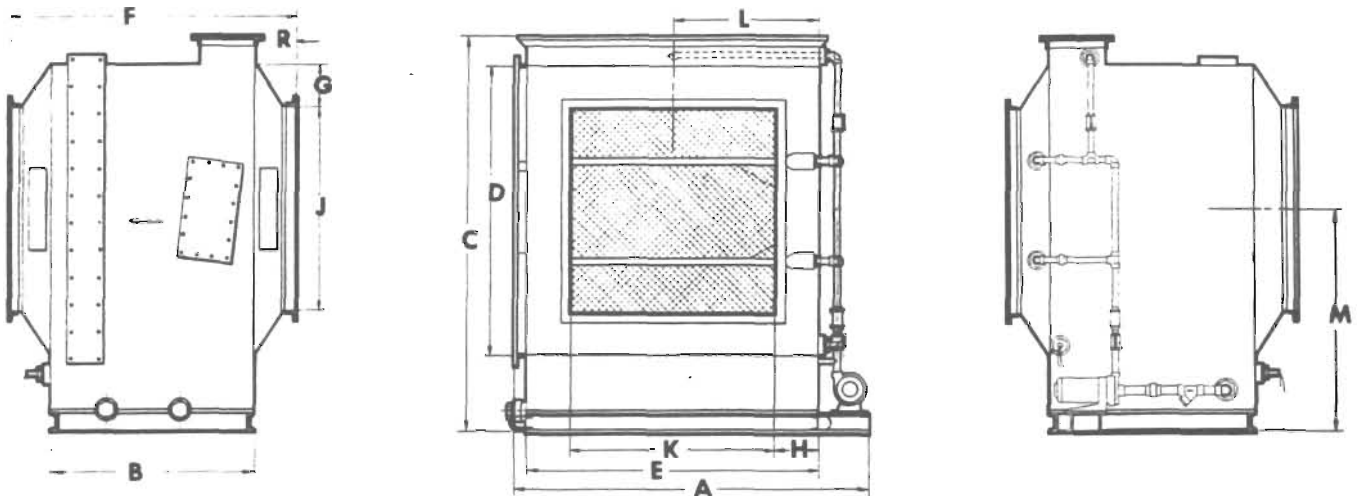

Typical three view drawing of units with integral recirculation tanks.

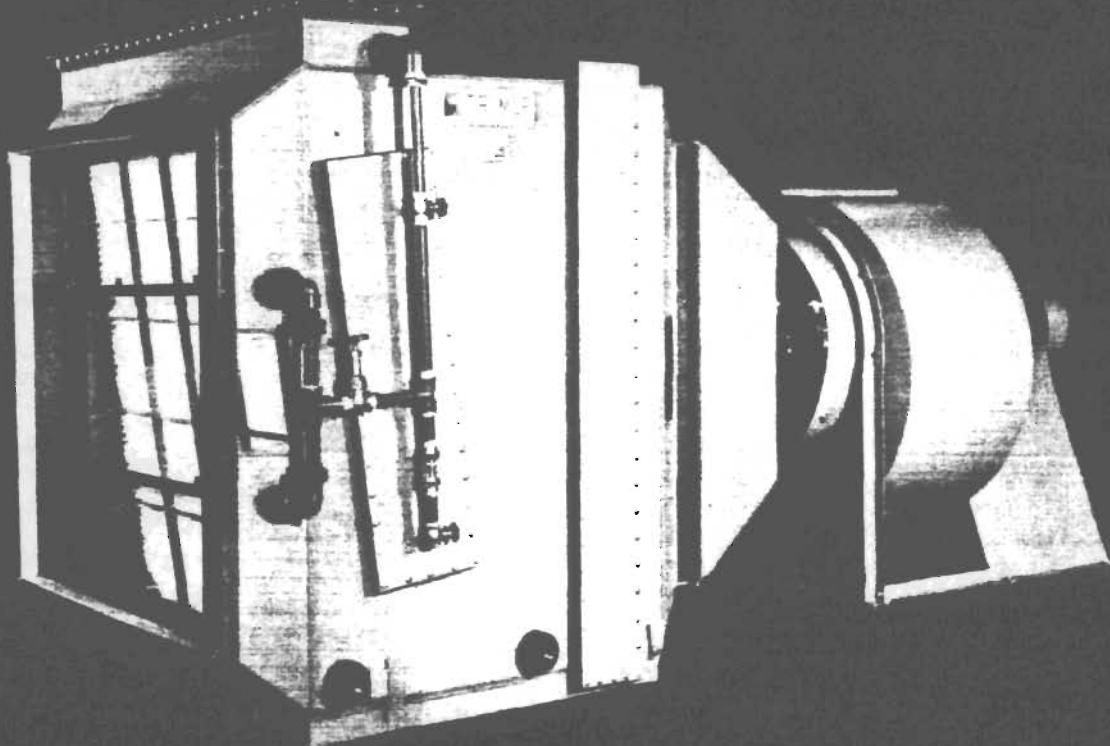

An assembled FW-10 complete with Tri-Mer PVC Fan & Transition

# Other TRI-MER PVC Equipment

As long time specialists in designing corrosive fume control systems, TRI-MER offers a complete line of PVC air movers and associated equipment. This includes the patented fan/separator (fume scrubber), fume washers (crossflow scrubbers), PVC centrifugal fans, an *all PVC* stack fan, as well as PVC hoods and duct. Special fabrications such as consoles, tanks, and small plating lines are available.

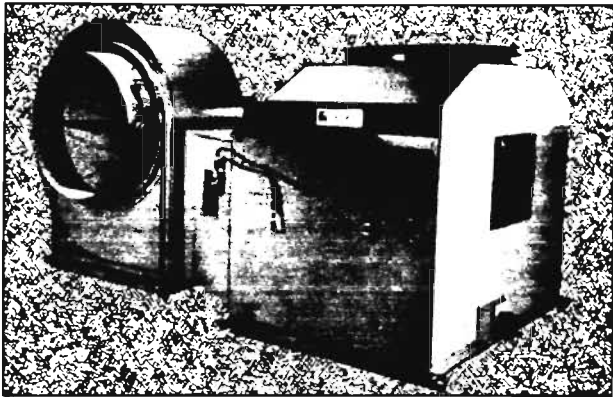

Fan/Separator

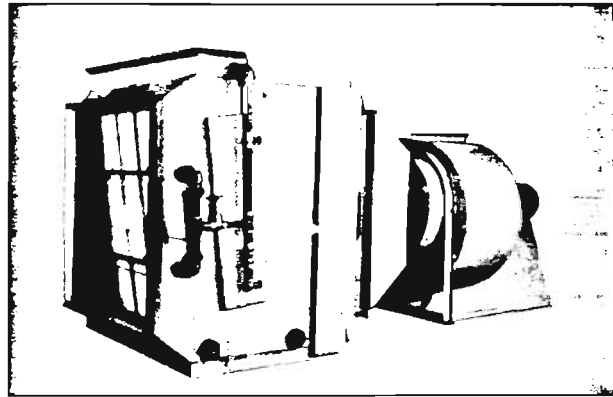

Fume/Washer (Crossflow Scrubber)

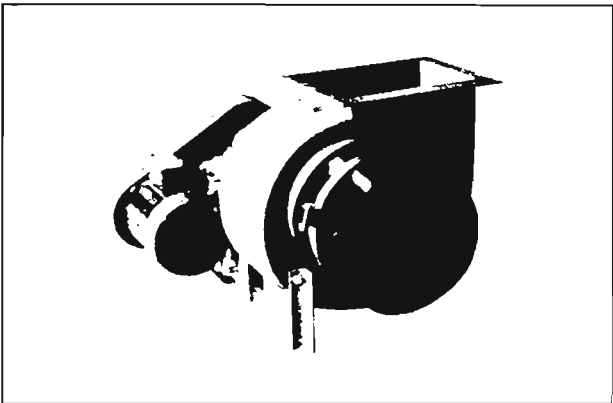

PVC Centrifugal Fan

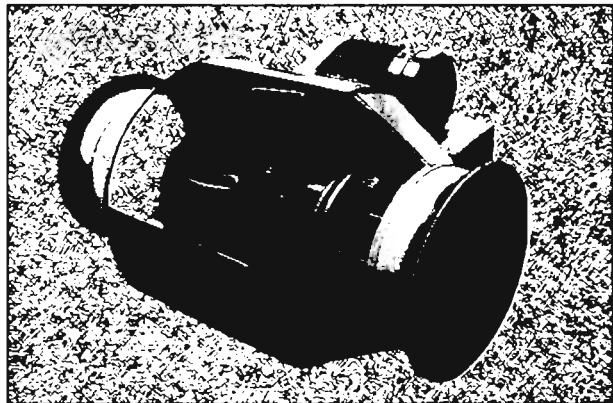

PVC Stack Fan (Cutaway View)

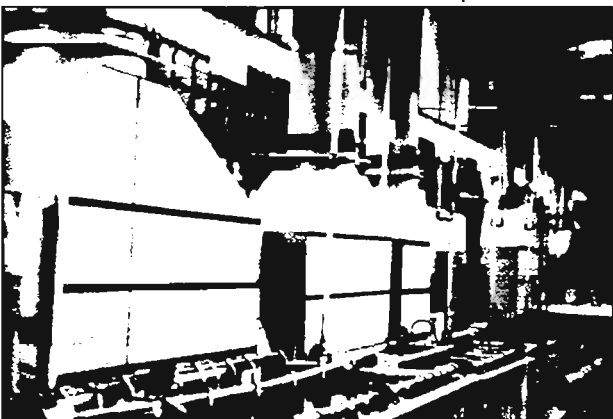

PVC Hoods & Duct

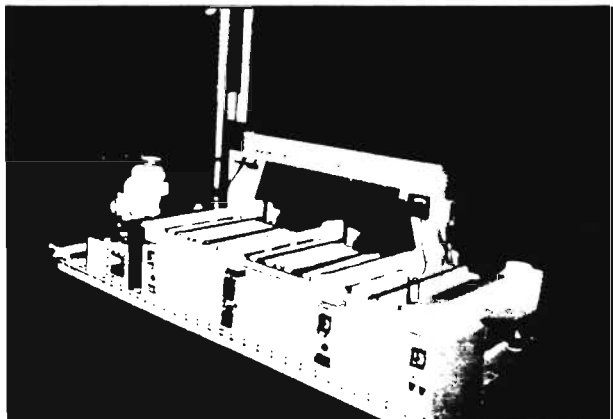

Special Fabrications



**Tri-Mer Corporation**

Factory and Main Offices  
1400 Monroe, Owosso, Michigan 48867  
Phone (517) 723-7838 Telex 228545



**Tri-Mer Corporation**

California Sales Offices  
P.O. Box 1152, Costa Mesa, California 92626  
Phone (714) 548-5853

**K** EUROPEAN REPRESENTATIVE  
**JAEGER K. G.**  
D BRAUNSCHWEIG, WEST GERMANY





W. K. DUSLEY INC.  
P. O. DRAWER 750  
650 AVE. B, S.W.  
WINTER HAVEN, FLA. 33880  
813 - 324-4000

# Harrison Plastic Packed Scrubbers

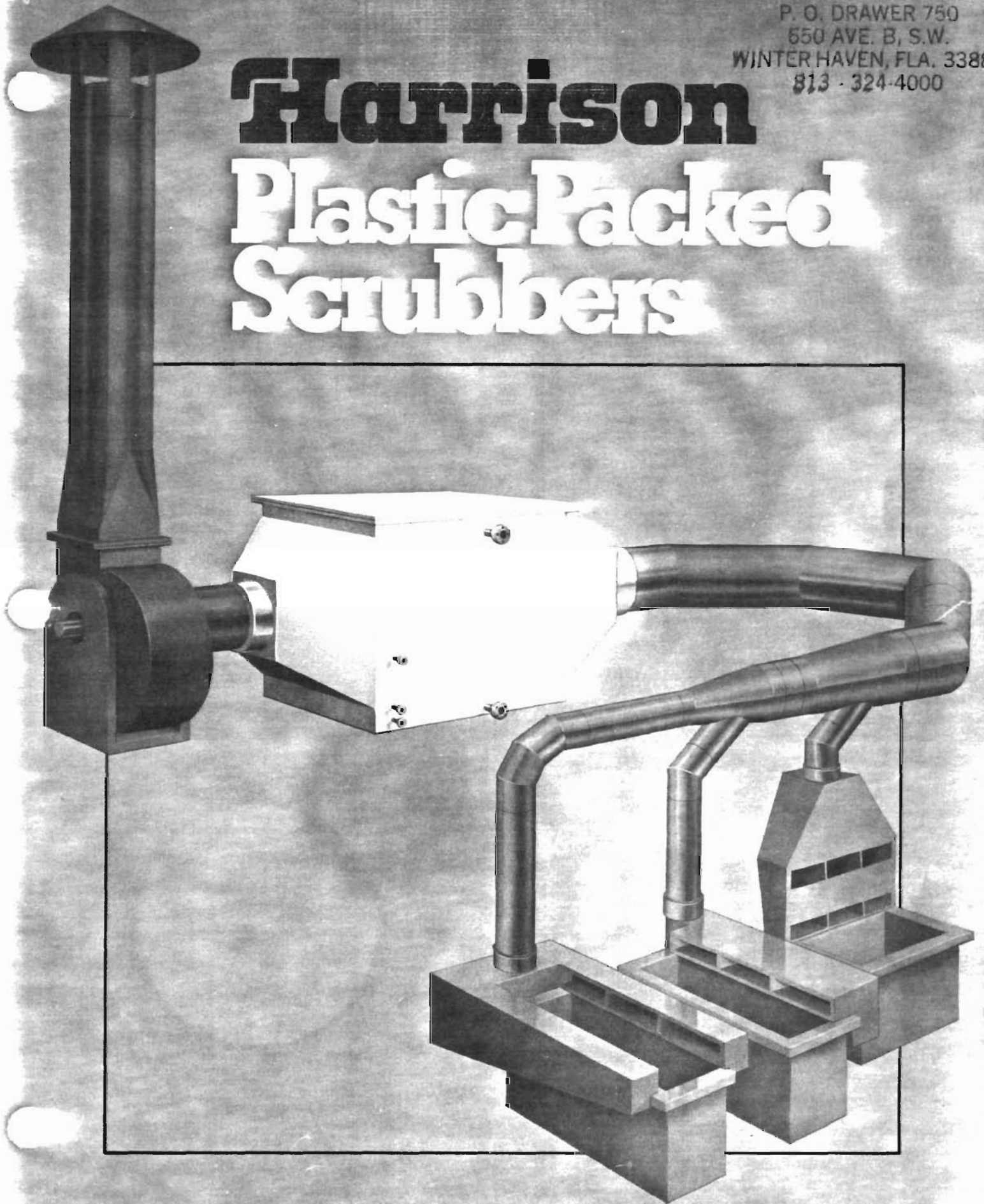

## THE HARRISON SYSTEM

Harrison is a prime designer and producer of complete plastic exhaust systems, custom engineered scrubbing systems, as well as duct and fittings, tanks, and hoods. As a result of this capability and experience, design and manufacture of standard, pre-engineered, fume scrubbers is a natural extension.

### MATERIALS

Self-supporting or fiberglass armored PVC and Polypropylene, fiberglass armored Kynar, and solid fiberglass construction offers a wide range of resistance to acids, alkalis, solvents, and other corrosives at operating temperatures to approximately 250°F. Harrison systems do not use any metal in contact with the process stream.

### PRE-ENGINEERING

Pre-engineered design reduces cost by eliminating the necessity to re-invent each item ordered. It results in more reliable service thru improved workmanship achieved by repetitive production control, and speeds quotations and approval drawings because costs and designs are immediately available. In addition to significant savings in approval and order time, Harrison reduces delivery time by stocking scrubber components including packing, support grids, distributor plates, nozzles, duct reducers, and sheet stock.

### SCRUBBER CONFIGURATION

Most fume removal applications can be served by the two scrubber designs shown in this catalog. Vertical Counter Current style directs liquid down vertically, and unwanted fumes upward in the opposite direction. Horizontal Cross Flow unit directs liquid down vertically, but unwanted fumes are driven horizontally at 90° to the liquid. In both designs, liquid and fumes are inter-mixed in the packed bed section of the scrubber where fumes are removed by chemical reaction or water solubility. Scrubber shape does not affect performance. Horizontal design presents a low profile and is suitable where head room is limited. Verticals require more head room, but use only minimum floor space.

### SCRUBBER DESIGN AND OPERATION

Highest scrubber efficiency (volumetric % of contaminate removed) is obtained by having the proper amount of contact surface area (packing) wetted by sufficient liquid (recirculated liquid rate) for an optimum residence time (packing depth) to allow unwanted fumes to take a treacherous path thru the wetted packing to permit their maximum removal from the carrier air stream by chemical reaction or water solubility.

Air stream resistance encountered in the packing (static pressure loss) is a function of air velocity, cross-sectional packing area, and packing depth. Harrison scrubbers utilize proven packing depth to achieve efficiencies approaching 99+%, when operated within recommendations.

### LIQUID DISTRIBUTION AND MIST ELIMINATION

Simple liquid distribution is achieved thru a main header pipe feeding perforated laterals, without use of troublesome spray nozzles. Nozzles are subject to plugging, and produce a difficult-to-remove atomized mist carryover. In the Harrison design, any large droplets of liquid caught in the upward moving air stream are easily and efficiently removed by a short bed of dry packing located above the liquid distributor.

### STATIC PRESSURE LOSS

Use of high-surface-area, low-pressure-drop plastic saddles in a balanced design result in low static pressure loss of only 0.4 inches H<sub>2</sub>O (w.g.) per foot of packed depth in Vertical Counter Current scrubbers, and 0.33 in Horizontal Cross Flow units. At the same time, sufficient irrigation rates constantly keep saddles clear of potential sludge buildup. Thereby, continuous, non-clogging operation at a proper rate of intermixing turbulence between liquid and fumes is achieved for 99+% efficiency.

### LIQUID SUMP OPERATION

Harrison scrubbers employ an integral liquid recirculating sump which reduces amount of liquid consumption required by 90 to 95% in most applications. Therefore, considerably less effluent must be handled and treated. The sump reservoir is contained within the scrubber itself. Harrison recommends optimum rate of effluent removal. When effluent is acidic only, additional liquid conservation can be obtained with either scrubber design with the simple optional recovery system shown with the vertical scrubber drawing on page 4. If central treating facilities exist, no sump, recirculation, or independent recovery is needed. In this case, treated liquid would be directed over the packing in a single pass, then treated, then returned to the scrubber, etc. In both instances where effluent is treated, liquid consumption would be reduced to only that amount lost by evaporation.

# Harrison

Box 184 Aurora Ohio 44202/216-562-9545



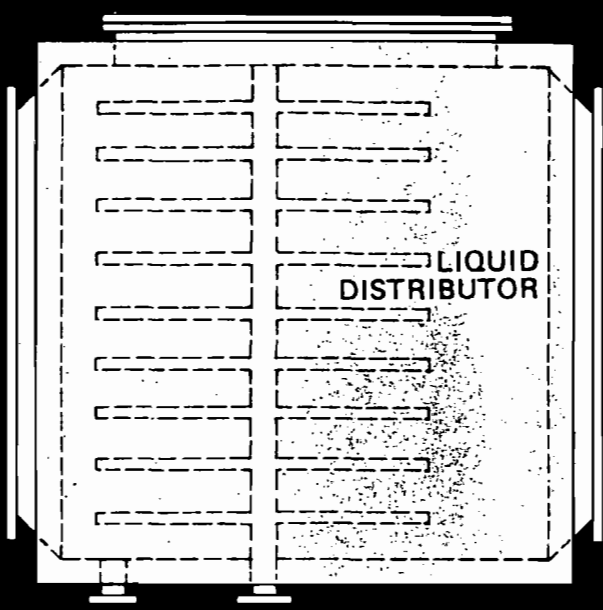
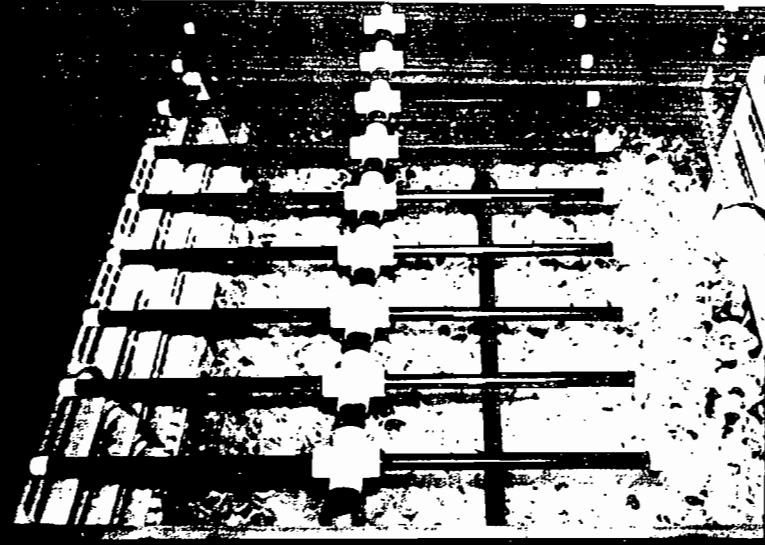

TOP VIEW

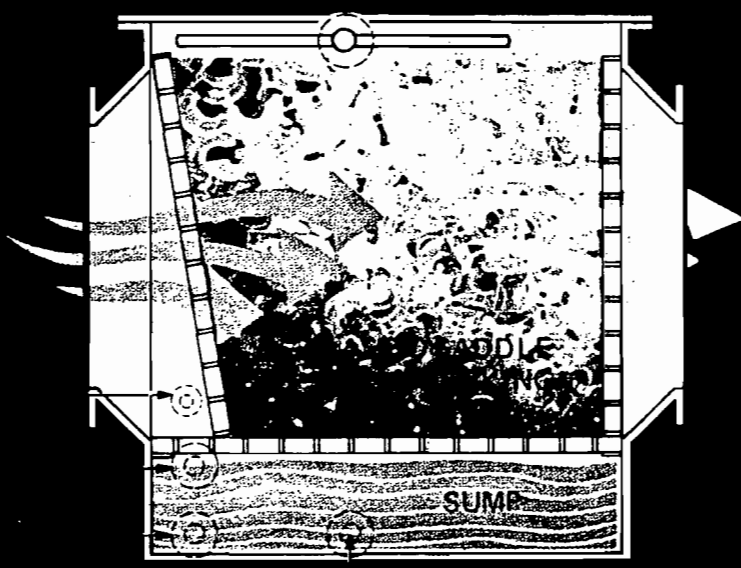

SIDE VIEW (CUT-A-WAY)

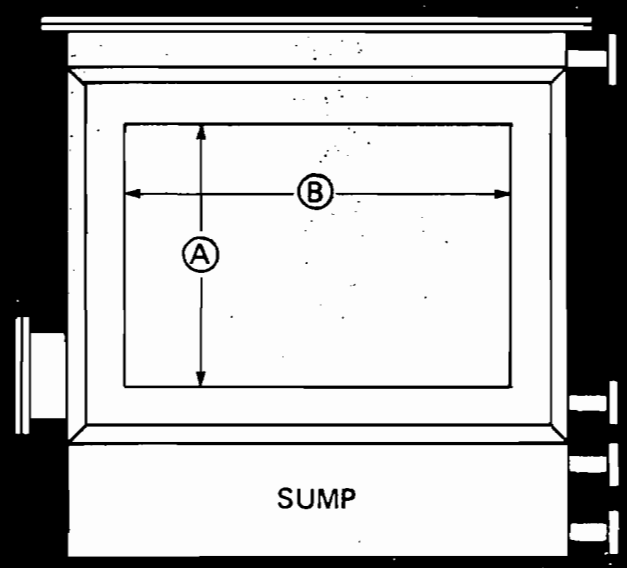

INLET SIDE VIEW

# HORIZONTAL CROSS-FLOW

Model	CFM	Inlet & Outlet A x B In.	Length L Ft.	Width W In.	C In.	D In.	E In.	F In.	G In.	Sump Capacity Gal.	Rec. Liquid GPM	Overall Height In.	Ship* Wt. Lbs.	Operating Wt. Lbs.
HF-8	800	11x11	6	17	¾	1	1	1½	1	58	17	35	182	646
HF-12	1,200	14x14	6	20	¾	1	1	1½	1	69	21	38	224	781
HF-17	1,700	18x18	6	24	¾	1	1	1½	1½	82	24	42	275	926
HF-21	2,100	21x21	6	27	¾	1	1	1½	1½	92	28	45	316	1028
HF-25	2,500	24x24	6	30	¾	1½	1½	1½	1½	102	32	48	357	1166
<del>HF-30</del> HF-31	<del>3,000</del> 3,100	27x27	6	33	¾	1½	1½	1½	1½	113	35	51	419	1313
HF-37	3,700	30x30	6	36	¾	1½	1½	1½	1½	125	39	54	481	1445
HF-45	4,500	33x33	6	39	¾	1½	1½	1½	1½	134	42	57	563	1669
HF-50	5,000	36x36	6	42	¾	1½	1½	1½	1½	144	45	5.0 ft.	615	1733
HF-67	6,700	36x36	6	48	1	2	2	1½	1½	165	51	5.5	690	1980
HF-85	8,500	42x42	6	54	1	2	2	2	1½	186	56	6.0	824	2276
HF-105	10,500	48x48	6	60	1	2	2	2	1½	206	60	6.5	1035	2639
HF-126	12,600	54x54	6	66	1	2	2	2	1½	228	68	7.0	1242	2990
HF-150	15,000	60x60	6	72	1	2	2	2½	2	247	74	7.5	1545	3460
HF-176	17,600	66x66	6	78	1	2	2	2½	2	268	80	8.0	1751	3803
HF-190	19,000	66x72	6	84	1	2	2	2½	2	300	86	8.0	1957	4161
HF-220	22,000	66x84	6	96	1	2	2	2½	2	330	98	8.0	2266	4770
HF-245	24,500	66x96	6	108	1½	2	2	3	3	371	112	8.0	2524	5328
HF-273	27,300	66x108	6	120	1½	2	2	3	3	412	123	8.0	2835	5980
HF-300	30,000	66x120	6	132	1½	2	2	3	3	454	136	8.0	3180	6684
HF-327	32,700	66x132	6	144	1½	2	2	3	3	495	147	8.0	3490	7398

BEST AVAILABLE COPY

# PVC

UNPLASTICIZED POLYVINYL CHLORIDE

## NON-OVERLOADING BLOWER

(BACKWARD INCLINED BLADES)

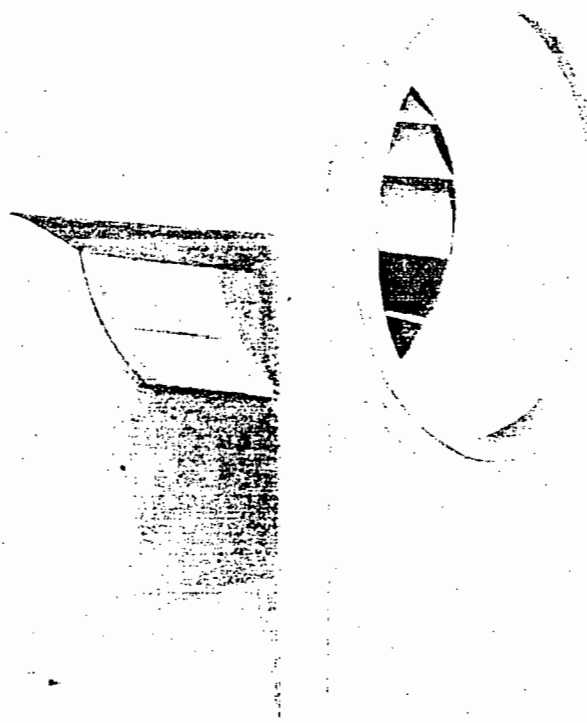

**Tri-Mer<sup>®</sup> Corporation**

**Air Pollution Control Systems**

*DESIGN • ENGINEERING • MANUFACTURING*

1400 Monroe Street • Owosso, Michigan 48867 • 517-723/5124 • Telex 228545

# STANDARD NOMENCLATURE

## Direction of Rotation and Discharge

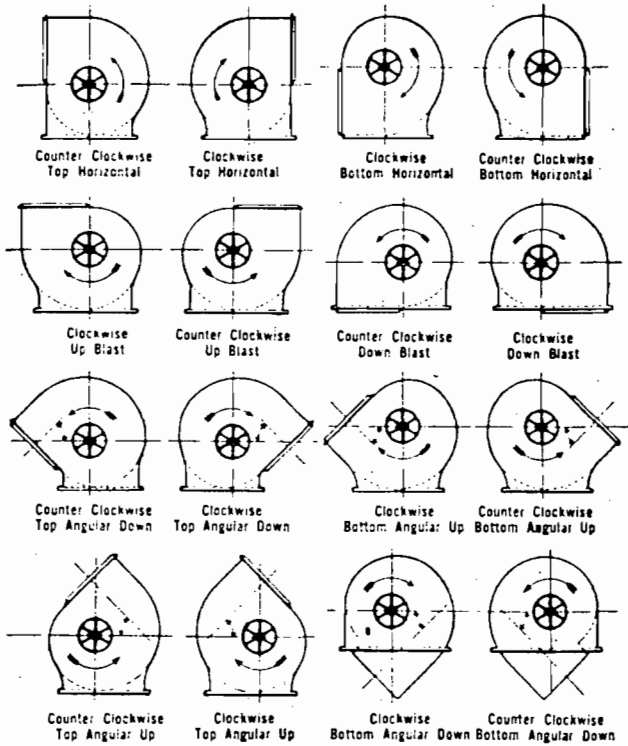

Direction of rotation is determined from the drive side. On single inlet fans, drive side is considered as opposite inlet, regardless of actual drive location.

## STANDARD MOTOR POSITIONS

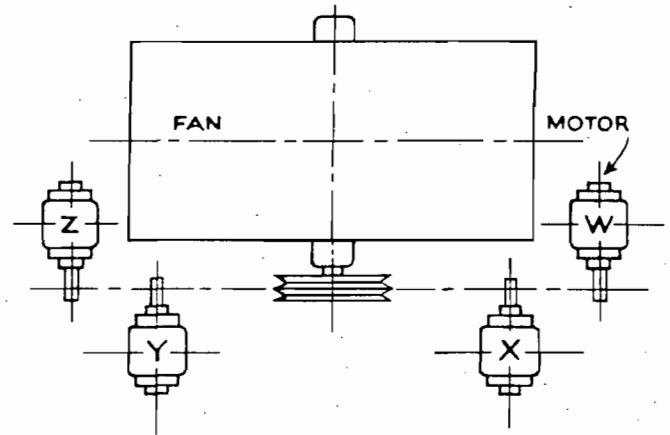

The location of motor is determined from plan view of the blower, designating the motor position by letters W, X, Y and Z as the case may be.

## ARRANGEMENTS OF DRIVE

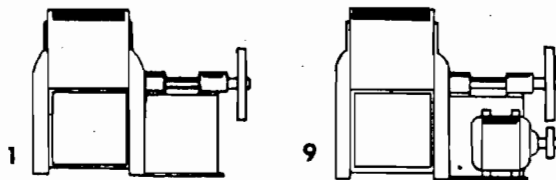

### ARRANGEMENT No. 1, SWSI

For belt drive or direct connection. Wheel overhung. Two bearings on base. Furnished in sizes 122 to 600 inclusive. Single inlet only.

### ARRANGEMENT No. 9, SWSI

For belt drive. Arrangement No. 1 designed for mounting prime mover on side of base. Furnished in sizes 122 to 600 inclusive. Single inlet only.

### SWSI - Class II

Heavier design than Class I. A one piece intermediate stiffening ring is also welded into each blade. Tip speed limit approximately 13000 FPM and 6 inches total pressure.

## CONSTRUCTION FEATURES

- HOUSING—All P.V.C.
- WHEEL—P.V.C. and Coated Steel
- INLET—1½" P.V.C. Angle Flange
- OUTLET—1½" P.V.C. Angle Flange
- DRAIN—2" P.V.C. Flanged
- CLEANOUT DOOR—P.V.C. Bolted
- STEEL FRAME—Epoxy Coated

Blowers are very rugged with heavy angle iron bracing, over capacity shaft and bearings. Formed P.V.C. venturi inlets give streamlined flow into the wheel with its own matching cone for very high efficiency and quiet operation. OPERATING TEMPERATURES UP TO 155°F.

Fiber

Centrifugal Blowers

Blowers

W. K. OUSLEY INC  
P. O. DRAWER 750  
650 AVE. B, S.W.  
WINTER HAVEN, FLA. 33880  
813 - 324-4000

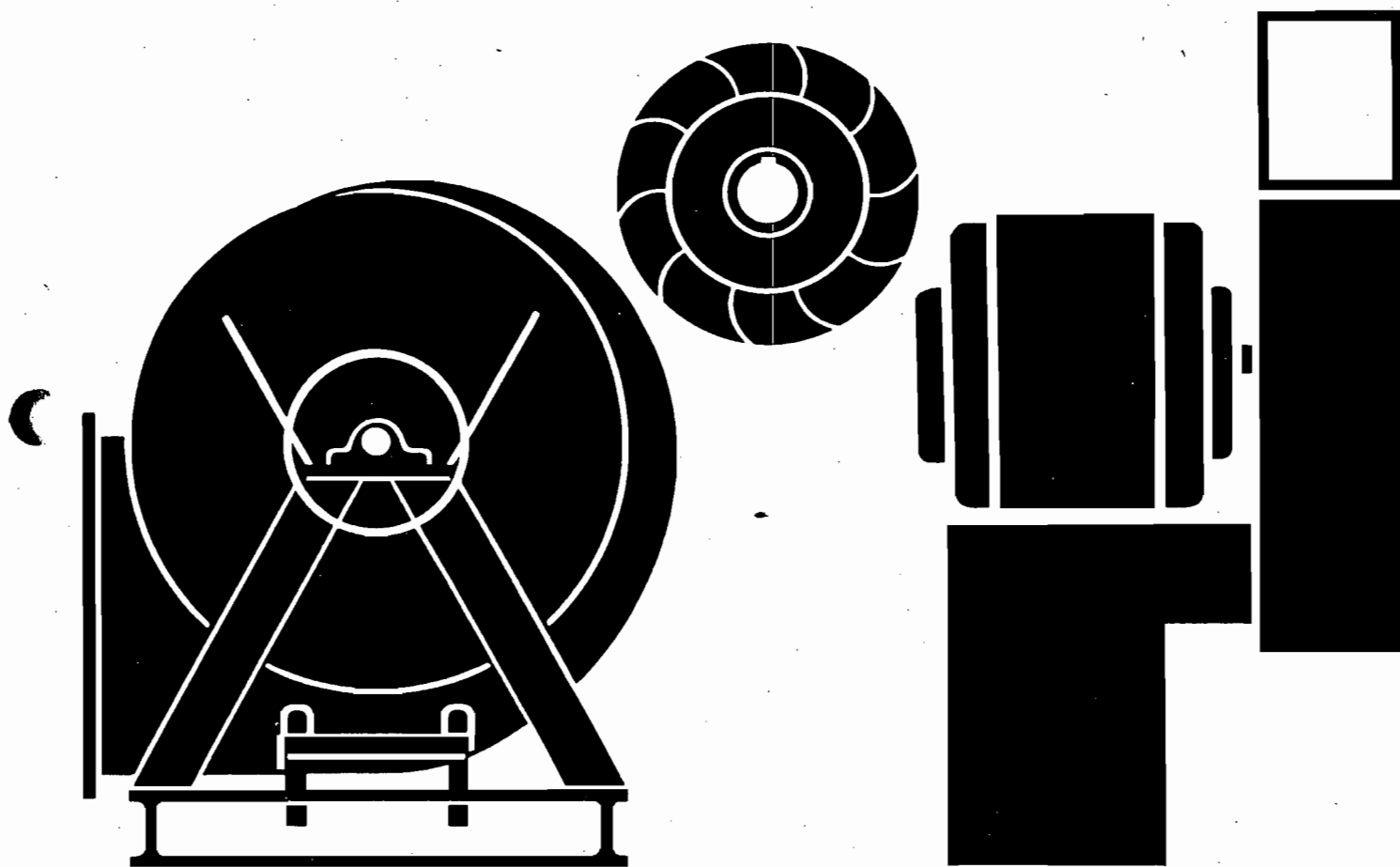

**HARTZELL**

Hartzell Fan, Division of Castle Hills Corporation, Piqua, Ohio

# Construction Features

A variety of corrosion problems plague industry today. Fans and blowers made of coated steel or metals such as stainless and monel can handle some problem areas. However, reinforced fiberglass and resin construction will meet even the most challenging demands.

Fiberglass centrifugal blowers can be used in most applications where corrosive elements exist in fume and vapor form at temperatures less than 200° F. The resistance to corrosive elements is a major advantage, but the physical properties of fiberglass equipment offer these additional advantages.

- Fiberglass equipment weighs 25% less than comparable equipment made of carbon steel.
- Fiberglass has an extremely high strength-to-weight ratio, stronger than steel on a per-pound basis.
- Dimensional stability of fiberglass is excellent. Fiberglass air moving equipment will not become brittle at low temperatures and at 0° F. the laminated fiberglass will be stronger than at room temperature.
- Fiberglass equipment offers a distinct advantage in price over stainless and monel (as much as 1/3 in original cost) and offers longer service life and requires less maintenance.

Hartzell fiberglass equipment is identical, except for part thickness, in design, overall specs and performance to our standard lines. The following are standard Hartzell fiberglass construction features:

- Special corrosive resistant polyester resin having a Class I flame spread rate of 25 or less.
- All structural parts in the airstream are fiberglass and resin. All taped joints inside the shell or body are three layers of two ounce material. All internal surfaces are protected with a 10 mil thickness of chemical resistant, flame retardant gel coat and all external surfaces have a heavy coating of resin applied before assembly.
- Internal hardware is 300 series stainless steel. Shafts are type 304; bolts and screws are type 316. Monel shafting and hardware are available as an extra-cost option for applications such as hydrochloric, hydrofluoric, or sulfuric acids, which attack stainless.

Where metal is subject to attack by the corrosive elements being handled, all metal parts can be resin-coated after assembly.

- A fiberglass and neoprene shaft seal is placed where the shaft leaves the housing along with a neoprene shaft slinger between the seal and wheel on belt drive units. (Seal is not gas tight.)
- All fiberglass radial and backward curved wheels are of multi-piece construction bonded together with resin and fiberglass material.

Maximum temperature limitation is 200° F. on all centrifugal blowers.

- All internal mounting hardware is encapsulated with a layer of fiberglass and resin.

**This bulletin lists Hartzell's complete line of fiberglass centrifugal blowers and accessories. More than 70 Hartzell offices can provide specific performance and installation data to meet your requirements. Call your nearest Hartzell representative for competent technical help.**

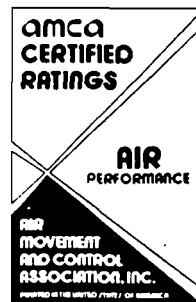

## Air Movement and Control Association Seal

Hartzell Propeller Fan Company certifies that the centrifugal blowers shown herein are licensed to bear the AMCA Seal. The ratings shown are based on tests made in accordance with AMCA Standard 210 and comply with the requirements of the AMCA Certified Ratings Program.

41-15-GO3

# Selection Guide

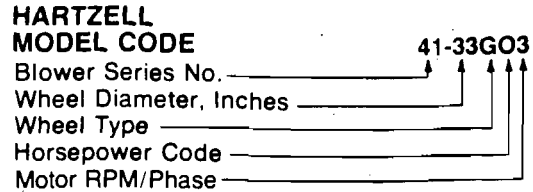

3 Phase 3 = 1750  
1 Phase C = 1750

## How To Use Capacity Tables

- (1) Select size, RPM and BHP for a given air delivery and pressure of a centrifugal blower from rating tables, pages 10 through 21. Performance ratings are based on standard air conditions, sea level 70°F. and 29.92 inches barometric pressure giving an air density of .075 lbs. per cubic foot. The specific gravity of air equals 1.00 at these conditions.
- (2) If non-standard temperature or altitude is involved, correct to standard air density (see Table 1).
- (3) For speeds above ratings consult factory.

## How to use Hartzell Model Code

**EXAMPLE:**  
Assume the required performance to be 16,276 CFM at 3" SP standard air. Reading across the 33" Rating Table, page 13, we find a blower RPM of 1306 and brake horsepower of 14.5. Motor horsepower required is 15; therefore, horsepower code is "O". Type specification would be "GO3". The complete blower specification would read: Series 41-33-GO3.

## Horsepower Code

Horsepower	¼	⅓	½	¾	1	1½	2	3	5	7½	10	15	20	25	30	40	50	60	75	100
Code Letter	D	E	F	G	H	I	J	K	L	M	N	O	P	Q	R	S	T	U	V	W

## Altitude - Temperature Correction

Temperatures above or below 70° at sea level (0 ft.) are read vertically between the double lines, giving the proper correction factors. Altitudes above sea level at a constant 70°F. temperature are read horizontally between the double lines giving those factors. Any other factors are obtained by reading down to the desired temperature, then across to the desired altitude.

### Example:

Assume the required performance to be 12,520 CFM at 6.15" SP, 175° F. and 2000 feet altitude.  
1. Table 1 gives a factor of 1.30.

2. 6.15" SP × 1.30 = 8.0" SP for 70° F. at sea level.
3. A backward curved centrifugal blower, size 33", selected from the rating tables for the new condition shows 12,520 CFM at 8.0" SP, 1537 RPM and 23.9 BHP.
4. Correct the horsepower and static pressure in Item 3 to non-standard performance by dividing by the factor:  
8.0" SP ÷ 1.30 = 6.15 SP  
23.9 BHP ÷ 1.30 = 18.38 BHP
5. Final performance of this size 33" backward curved centrifugal blower at assumed conditions:  
12,520 CFM at 6.15" SP, 1537 RPM, 18.38 BHP, 175°F. and 2000 Ft.

Table 1 - Combined Altitude - Temperature Correction Factors

ALT. FT. / °F. TEMP.	0	1000	2000	3000	4000	5000	6000	7000	8000	9000	10000	11000	12000
-50	0.77	0.80	0.83	0.86	0.89	0.92	0.96	1.00	1.04	1.08	1.12	1.16	1.21
-25	0.82	0.85	0.89	0.92	0.95	0.98	1.03	1.07	1.11	1.15	1.20	1.24	1.29
0	0.87	0.90	0.94	0.97	1.01	1.04	1.09	1.13	1.17	1.22	1.27	1.31	1.37
25	0.91	0.95	0.98	1.02	1.06	1.09	1.14	1.18	1.23	1.27	1.33	1.37	1.43
50	0.96	1.00	1.04	1.08	1.11	1.15	1.20	1.25	1.30	1.34	1.40	1.45	1.51
70	1.00	1.04	1.08	1.12	1.16	1.20	1.25	1.30	1.35	1.40	1.46	1.51	1.57
100	1.06	1.10	1.14	1.19	1.23	1.27	1.33	1.38	1.43	1.48	1.55	1.60	1.66
125	1.10	1.14	1.19	1.23	1.28	1.32	1.38	1.43	1.49	1.54	1.61	1.66	1.73
150	1.15	1.20	1.24	1.29	1.33	1.38	1.44	1.50	1.55	1.61	1.68	1.74	1.81
175	1.20	1.25	1.30	1.34	1.39	1.44	1.50	1.56	1.62	1.68	1.75	1.81	1.88
200	1.25	1.30	1.35	1.40	1.45	1.50	1.56	1.63	1.69	1.75	1.83	1.89	1.96
250	1.34	1.39	1.45	1.50	1.55	1.61	1.68	1.74	1.81	1.88	1.96	2.02	2.10
300	1.43	1.49	1.54	1.60	1.66	1.72	1.79	1.86	1.93	2.00	2.09	2.16	2.25
350	1.53	1.59	1.65	1.71	1.77	1.84	1.91	1.99	2.07	2.14	2.23	2.31	2.40
400	1.62	1.69	1.75	1.82	1.89	1.96	2.04	2.12	2.20	2.27	2.35	2.45	2.55
450	1.72	1.79	1.86	1.93	2.00	2.08	2.16	2.24	2.33	2.41	2.50	2.60	2.70
500	1.81	1.88	1.96	2.03	2.11	2.19	2.28	2.36	2.46	2.54	2.62	2.74	2.85
550	1.91	1.98	2.06	2.14	2.22	2.30	2.40	2.49	2.58	2.68	2.77	2.89	3.00
600	2.00	2.08	2.16	2.24	2.33	2.42	2.50	2.61	2.71	2.80	2.90	3.03	3.14

NOTE: Above table has inverted values. Actual density is the reciprocal of the above values.

# Abrasive/Erosive Atmospheres

HartKoate is an abrasive/erosive resistant coating developed by Hartzell for application in environments where abrasive/erosive conditions may exist. HartKoate helps prevent premature deterioration of equipment in environments where uncoated fans may fail.

Impact resistant HartKoate is applied to a 50-60 mil thickness suitable for temperatures to 200°F.

HartKoate is particularly appropriate for use when water mist and/or abrasive particles exist in the air stream.

Contact your Hartzell representative for further details concerning the application of HartKoate coating to fiberglass fans in corrosive atmospheres.

## Installation Weights- Bearing/Shaft Sizes

### Series 41

Size	Type	Net Wt. (lbs.)	Shaft/Bearing Sizes	Size	Type	Net Wt. (lbs.)	Shaft/Bearing Sizes	Size	Type	Net Wt. (lbs.)	Shaft/Bearing Sizes	Size	Type	Net Wt. (lbs.)	Shaft/Bearing Sizes								
15"	GH3	526	17/16"	40"	GI3	1885	27/16"	19"	FI3	372	17/16"	30"	FL3	626	115/16"								
	GI3	526	17/16"		GJ3	1885	27/16"		FJ3	372	17/16"		FM3	629	115/16"								
	GJ3	529	17/16"		GK3	1912	27/16"		FK3	399	17/16"		FN3	649	115/16"								
	GK3	529	17/16"		GL3	1932	27/16"		FL3	444	17/16"		FO3	709	115/16"								
	GL3	549	17/16"		GM3	1972	27/16"		FM3	447	17/16"		FP3	739	115/16"								
	GM3	554	17/16"		GN3	1987	27/16"		FN3	466	17/16"		FQ3	779	115/16"								
22"	GH3	772	111/16"	49"	GO3	2047	27/16"	23"	FO3	517	17/16"	33"	FR3	869	115/16"								
	GI3	772	111/16"		GP3	2077	27/16"		FP3	547	17/16"		FS3	909	115/16"								
	GJ3	776	111/16"		GQ3	2127	27/16"		FQ3	587	17/16"		FT3	1004	115/16"								
	GK3	776	111/16"		GR3	2177	27/16"		FR3	667	17/16"		*FU3	529	115/16"								
	GL3	806	111/16"		GL3	2415	215/16"		26"	FJ3	404		111/16"	Series 42	10"	FC3	63						
	GM3	813	111/16"		GM3	2465	215/16"			FK3	431		111/16"					12"	FF3	78			
GN3	854	111/16"	GN3	2483	215/16"	FL3	451	111/16"		14"	FG3	96											
GO3	865	111/16"	GO3	2558	215/16"	FM3	496	111/16"															
GP3	926	111/16"	GP3	2596	215/16"	FN3	516	111/16"															
27"	GI3	954	115/16"	GR3	2721	215/16"	FO3	535					111/16"								Series 42	10"	FC3
	GJ3	959	115/16"	GS3	2846	215/16"	FP3	565	111/16"				12"	FF3	78								
	GK3	959	115/16"	GT3	2908	215/16"	FQ3	605	111/16"							14"	FG3	96					
	GL3	996	115/16"	GU3	2958	215/16"	FR3	695	111/16"														
	GM3	1004	115/16"	GV3	3063	215/16"	FS3	845	111/16"														
	GN3	1054	115/16"	GW3	3123	215/16"	FT3	940	111/16"														
GO3	1069	115/16"	<b>Series 43</b>				Series 42	10"	FC3	63													
GP3	1144	115/16"	16"	FH3	302	13/16"					12"	FF3	78										
GQ3	1164	115/16"		FI3	302	13/16"								14"	FG3	96							
GR3	1190	115/16"		FJ3	302	13/16"																	
33"	GI3	1355		23/16"	FK3	338											13/16"	Series 42	10"	FC3	63		
	GJ3	1355		23/16"	FL3	358											13/16"					12"	FF3
	GK3	1382		23/16"	FM3	361	13/16"	14"	FG3	96													
	GL3	1397	23/16"	FN3	380	13/16"																	
	GM3	1454	23/16"	FO3	431	13/16"																	
	GN3	1482	23/16"	FP3	460	13/16"																	
GO3	1514	23/16"	<b>Series 43</b>				Series 42				10"	FC3	63										
GP3	1544	23/16"	16"	FH3	302	13/16"								12"	FF3	78							
GQ3	1594	23/16"		FI3	302	13/16"		14"	FG3	96													
GR3	1644	23/16"		FJ3	302	13/16"																	
Series 42	10"	FC3		63	16"	FK3											338	13/16"	12"	FF3	78		
						12"											FF3	78				14"	FG3
							14"				FG3	96											
			Series 42										10"	FC3	63								
								12"	FF3	78													
																14"							
Series 42	10"	FC3		63																			
					12"	FF3											78						
							14"				FG3	96											

\*Net installation weights are for Arrangement 1. (Less motor & drive.)

### Metric Conversion Table

FROM	TO	MULTIPLY BY
Inches (in.)	Millimeter (mm)	25.400
Feet (ft.)	Meter (m)	0.3048
Velocity (ft./min.)	Meter/Second (m/s)	0.00508
Volume Flow (cfm)	Cubic Meter/Second (m <sup>3</sup> /s)	0.00047195
Pressure (in. w.g.)	Pascal (N/m <sup>2</sup> )	248.36
Density (lb./ft. <sup>3</sup> )	Kilogram /Cubic Meter (Kg/m <sup>3</sup> )	16.018
Power (hp)	Watt (w)	745.70
Square Foot (ft. <sup>2</sup> )	Square Meter (m <sup>2</sup> )	0.09290
Square Inch (in. <sup>2</sup> )	Square Meter (m <sup>2</sup> )	0.0006451



# Backward Curved Blower (Belt Drive)

## Blowers available in SWSI only

The belt drive airfoil backward curved centrifugal blower offers non-overloading efficiency and economy in corrosive atmospheres at static pressures up to 12". The wheel and housing are constructed with a special corrosive resistant polyester resin having a Class I flame spread rate of 25 or less. No metal parts are exposed in the airstream. All internal hardware is 300 series stainless steel encapsulated with fiberglass.

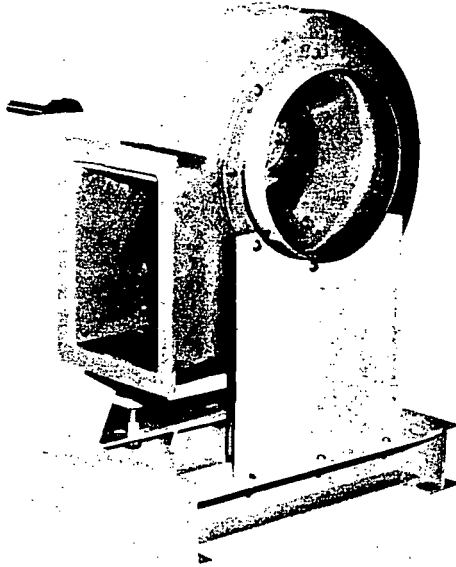

Arrangement #10 Shown.



Series 41



## Features

- **Sizes** — 15", 22", 27", 33", 40", 49" wheel diameters.
- **Arrangements** — available in Arrangements #1, #9 or #10.
- **Rotation** — clockwise and counter clockwise rotation. Rotatable in field.
- **Discharges** — available discharges shown on page 9.
- **Packaged unit** — motor and drive mounted by factory.
- **Easy installation and maintenance** — motor, drive and bearings are readily accessible for ease in wiring, installation, adjustment and lubrication.
- **Wheel** — a true airfoil type of multi-piece, solid fiberglass construction bonded together with resin and fiberglass material. Airfoil backwardly inclined blades offer greater versatility for industrial applications. Wheel has non-overloading horsepower characteristics in that brake horsepower levels off at a point that prevents motor overload if system changes occur. Wheel Type G.
- **Motors** — open end drip proof are standard. Totally enclosed fan cooled and other special motors are available upon request.
- **Variable pitch drives** are standard on all units up to 10 HP.
- **Flanged outlets are standard.** Inlet flanges are optional. Drilling of flanges is optional. (Position of drilled holes must be specified by customer.)
- **All units are test run and electronically balanced** before shipment.
- **Heavy Duty Design** suitable for service up to and including Class III.
- **Bearings** — heavy duty, self-aligning, double row spherical roller type pillow block bearings are standard and are furnished with extended lubrication lines. Bearings have floating labyrinth seals. (See page 7 for Bearing/Shaft sizes.)
- **Shafts** are 304 stainless steel as standard. Monel available at extra cost.
- **Bases** — heavy gauge hot rolled steel, epoxy coated.
- **Maximum Temperature:** 200° F.
- **Maximum tip speed:** 16,000 FPM
- **Accessories** —  
See pages 22 and 23.

## Principal Dimensions

Size	Wheel Dia.	A	B	C	D	E	F	H	K	L	M	P	R	T	Max. Motor Frame Size	
															ODP	TEFC
15	15 <sup>5</sup> / <sub>16</sub>	32 <sup>1</sup> / <sub>2</sub>	33 <sup>1</sup> / <sub>2</sub>	16 <sup>3</sup> / <sub>8</sub>	11 <sup>1</sup> / <sub>16</sub>	30 <sup>1</sup> / <sub>4</sub>	41	12 <sup>1</sup> / <sub>16</sub>	14 <sup>9</sup> / <sub>16</sub>	16 <sup>3</sup> / <sub>16</sub>	19	16	16 <sup>7</sup> / <sub>16</sub>	31 <sup>3</sup> / <sub>4</sub>	326T	286T
22	22 <sup>9</sup> / <sub>16</sub>	32 <sup>1</sup> / <sub>2</sub>	33 <sup>1</sup> / <sub>2</sub>	23 <sup>5</sup> / <sub>8</sub>	17 <sup>1</sup> / <sub>8</sub>	30 <sup>1</sup> / <sub>4</sub>	46	18 <sup>7</sup> / <sub>16</sub>	21 <sup>3</sup> / <sub>16</sub>	21 <sup>1</sup> / <sub>4</sub>	21 <sup>1</sup> / <sub>2</sub>	23	23 <sup>15</sup> / <sub>16</sub>	31 <sup>3</sup> / <sub>4</sub>	326T	286T
27	27 <sup>3</sup> / <sub>4</sub>	38 <sup>1</sup> / <sub>4</sub>	43	29	21	35 <sup>7</sup> / <sub>8</sub>	51	22 <sup>3</sup> / <sub>4</sub>	26 <sup>5</sup> / <sub>8</sub>	24	24	28	29 <sup>1</sup> / <sub>2</sub>	41 <sup>1</sup> / <sub>4</sub>	326T	286T
33	33 <sup>13</sup> / <sub>16</sub>	43 <sup>1</sup> / <sub>4</sub>	50	35 <sup>7</sup> / <sub>16</sub>	25 <sup>11</sup> / <sub>16</sub>	40 <sup>5</sup> / <sub>8</sub>	56	27 <sup>11</sup> / <sub>16</sub>	31 <sup>13</sup> / <sub>16</sub>	29 <sup>9</sup> / <sub>16</sub>	26 <sup>1</sup> / <sub>2</sub>	34 <sup>1</sup> / <sub>4</sub>	35 <sup>15</sup> / <sub>16</sub>	48 <sup>1</sup> / <sub>4</sub>	326T	286T
40	41 <sup>1</sup> / <sub>2</sub>	51 <sup>1</sup> / <sub>4</sub>	59	43 <sup>5</sup> / <sub>16</sub>	31 <sup>3</sup> / <sub>8</sub>	48 <sup>3</sup> / <sub>8</sub>	62	33 <sup>13</sup> / <sub>16</sub>	38 <sup>13</sup> / <sub>16</sub>	35 <sup>7</sup> / <sub>8</sub>	29 <sup>1</sup> / <sub>2</sub>	41 <sup>7</sup> / <sub>8</sub>	43 <sup>7</sup> / <sub>8</sub>	57 <sup>1</sup> / <sub>4</sub>	326T	286T
49	50 <sup>9</sup> / <sub>16</sub>	61 <sup>3</sup> / <sub>8</sub>	73	52 <sup>5</sup> / <sub>8</sub>	38 <sup>1</sup> / <sub>8</sub>	58	92	41	47 <sup>5</sup> / <sub>8</sub>	40	44 <sup>1</sup> / <sub>2</sub>	50 <sup>13</sup> / <sub>16</sub>	53 <sup>1</sup> / <sub>4</sub>	71 <sup>1</sup> / <sub>4</sub>	447T	447T

NOTES: ON 15 AND 22 SIZES WITH 254T FR. AND LARGER MOTORS, BASE DIMENSIONS MUST BE CERTIFIED BY THE FACTORY. DIMENSIONS AND SPECIFICATIONS ARE SUBJECT TO CHANGE. CERTIFIED PRINTS ARE AVAILABLE.

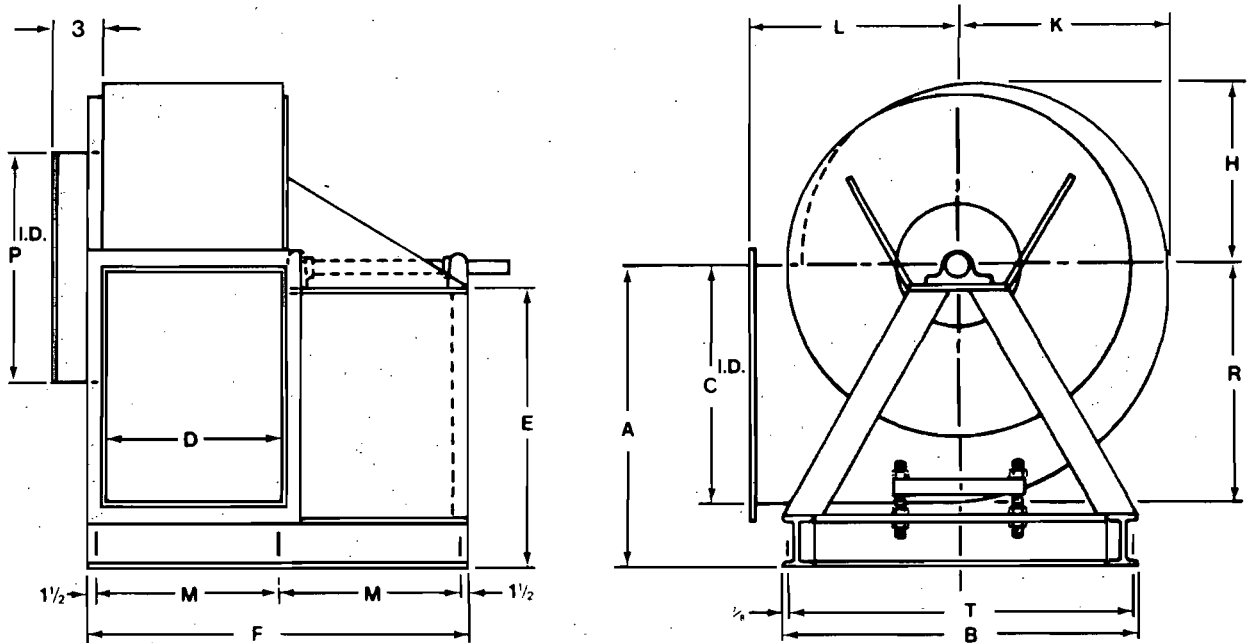

## Material Specifications — Inches

Size	HOUSING (Thickness)				(H.R.S.) FAN STAND			WHEEL (Thickness)		
	Scroll	Inlet Cone	Flanges		Back Plate	H-Beam	Channel	Blade	Back Plate	Outer Panel
			Inlet	Outlet						
15	5/16	5/16	3/16	5/16	1/2	6 x 4	4	1/4	1/2	1/2
22	5/16	7/16	1/4	5/16	1/2	6 x 4	4	1/4	5/8	5/8
27	1/2	1/2	5/16	1/2	1/2	6 x 4	4	5/16	3/4	3/4
33	1/2	5/8	3/8	1/2	1/2	6 x 4	4	3/8	7/8	7/8
40	9/16	3/4	7/16	9/16	1/2	6 x 4	4	7/16	1	1
49	5/8	15/16	9/16	5/8	1/2	6 x 4	4	1	1 3/8	1 3/8

## Blower Discharges

### Clockwise

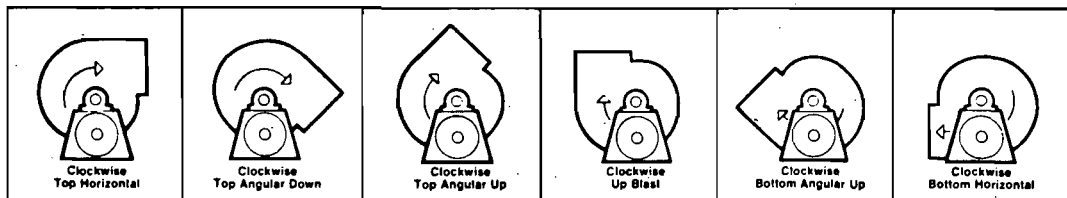

### Counterclockwise

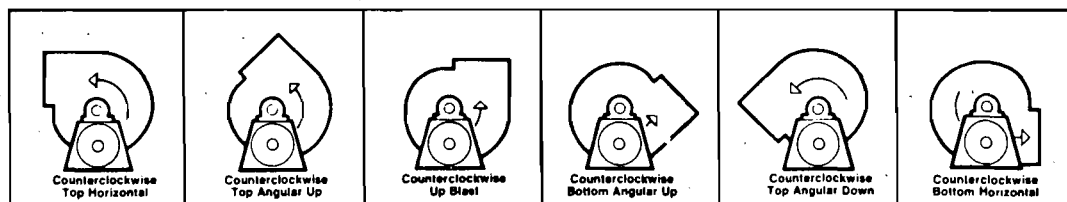

**15****Inlet diameter: 16" I.D.****Wheel diameter: 15.625"****Outlet area: 1.305 sq. ft. inside****Wheel circumference: 3.894 ft.****3000 CFM @ 3" SP 1**

	OV	½" SP		1" SP		1½" SP		2" SP		2½" SP		3" SP		3½" SP		4" SP		5" SP	
CFM	FPM	RPM	BHP	RPM	BHP	RPM	BHP	RPM	BHP	RPM	BHP	RPM	BHP	RPM	BHP	RPM	BHP	RPM	BHP
1044	800			1405	.32	1606	.47	1781	.62	1936	.80	2083	1.00	2224	1.19	2357	1.41	2597	1.85
1175	900			1475	.37	1664	.52	1835	.70	1989	.88	2132	1.07	2270	1.29	2397	1.51	2634	1.97
1305	1000	1319	.26	1545	.42	1725	.58	1897	.77	2046	.96	2186	1.16	2316	1.39	2440	1.61	2675	2.10
1436	1100	1405	.31	1616	.48	1803	.66	1958	.85	2112	1.06	2247	1.28	2375	1.51	2494	1.74	2720	2.24
1566	1200	1496	.38	1691	.54	1881	.76	2036	.96	2175	1.17	2312	1.40	2434	1.63	2556	1.88	2771	2.39
1697	1300	1583	.43	1782	.63	1952	.83	2107	1.06	2246	1.28	2375	1.52	2497	1.76	2614	2.02	2831	2.56
1827	1400	1675	.52	1863	.72	2030	.94	2175	1.16	2313	1.40	2438	1.65	2565	1.91	2675	2.17	2891	2.73
1958	1500	1764	.60	1947	.81	2109	1.05	2254	1.29	2385	1.53	2513	1.80	2631	2.07	2741	2.34	2954	2.91
2088	1600	1860	.70	2035	.93	2189	1.17	2328	1.42	2459	1.68	2586	1.95	2698	2.22	2807	2.51	3019	3.12
2219	1700	1956	.81	2119	1.05	2269	1.30	2401	1.55	2536	1.84	2655	2.11	2764	2.40	2880	2.70	3085	3.32
2349	1800	2042	.92	2205	1.18	2350	1.44	2486	1.72	2614	2.00	2727	2.30	2840	2.59	2950	2.90	3151	3.54
2480	1900	2143	1.07	2300	1.33	2438	1.60	2575	1.89	2693	2.19	2807	2.49	2919	2.80	3026	3.14	3221	3.79
2610	2000	2236	1.21	2383	1.48	2527	1.78	2656	2.08	2770	2.38	2888	2.70	2997	3.03	3104	3.37	3290	4.03
2871	2200	2425	1.53	2575	1.86	2704	2.17	2825	2.50	2943	2.83	3053	3.18	3162	3.54	3254	3.88	3439	4.59
3132	2400	2626	1.95	2760	2.28	2889	2.64	3002	2.98	3116	3.35	3222	3.72	3317	4.08	3413	4.45	3594	5.22
3393	2600	2819	2.40	2943	2.76	3061	3.12	3181	3.53	3283	3.91	3385	4.30	3482	4.70	3575	5.08	3733	5.83
3654	2800	3011	2.91	3138	3.34	3246	3.72	3352	4.12	3456	4.54	3557	4.97	3646	5.37	3727	5.75		
3915	3000	3215	3.56	3324	3.96	3432	4.39	3542	4.85	3636	5.27	3725	5.70	3810	6.12				
4176	3200	3398	4.19	3514	4.67	3620	5.14	3717	5.59	3809	6.04								
4437	3400	3611	5.03	3715	5.51	3809	5.97												
4698	3600	3810	5.90																

	OV	6" SP		7" SP		8" SP		9" SP		10" SP	
CFM	FPM	RPM	BHP	RPM	BHP	RPM	BHP	RPM	BHP	RPM	BHP
1044	800	2824	2.35	3032	2.87	3226	3.40				
1175	900	2857	2.48	3063	3.02	3252	3.56	3434	4.14	3608	4.75
1305	1000	2893	2.62	3092	3.17	3282	3.73	3459	4.32	3632	4.95
1436	1100	2935	2.77	3130	3.34	3315	3.92	3493	4.53	3661	5.17
1566	1200	2983	2.95	3175	3.52	3354	4.11	3530	4.75	3700	5.43
1697	1300	3032	3.12	3222	3.72	3399	4.33	3575	4.99	3736	5.67
1827	1400	3087	3.31	3269	3.92	3446	4.55	3618	5.24	3775	5.92
1958	1500	3150	3.53	3329	4.16	3500	4.80	3668	5.50	3824	6.20
2088	1600	3210	3.74	3387	4.40	3555	5.06	3718	5.76		
2219	1700	3268	3.95	3446	4.63	3611	5.33	3769	6.03		
2349	1800	3332	4.20	3507	4.90	3670	5.61	3825	6.32		
2480	1900	3403	4.47	3575	5.18	3734	5.90				
2610	2000	3470	4.74	3635	5.45	3793	6.19				
2871	2200	3610	5.33	3766	6.06						
3132	2400	3746	5.92								

Performance shown is with inlet and outlet ducts.  
RPM shown is nominal and performance is based on actual speed of test.  
BHP includes belt drive losses.

# DUST COLLECTORS

## NEW FILTRATION TECHNOLOGY

The new TD 486 is based on a unique combination of technologies. It involves the application of cartridge-type filters to a continuous-duty dust collection system. It offers you many advantages

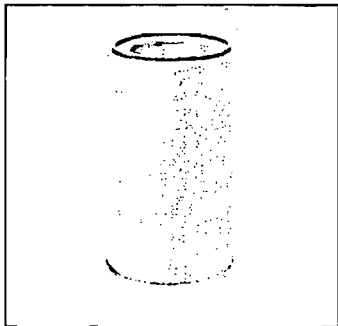

for treating large volumes of dust-laden air on a continuing basis: highly efficient filtration; increased filtering area for lower air-to-media ratios; increased ease of maintenance and operation; and substantially decreased collector headroom.

## EFFECTIVE FINE PARTICLE CONTROL

The use of pleated, non-woven filter media is the key to the TD 486's filtering efficiency. Dust-laden air enters through the inlet of the collector — heavy particles fall immediately into the hopper bottom. As the air is drawn in through the filter cartridges, dust is deposited on the outside of the filtering media. ~~With 9 filter cartridges, the system has 486 square feet of filter area, almost four times as much as a conventional collector of the same size. The generous filter area means low filtration velocity and high efficiency when handling sub-micron particulate.~~

## CONTINUOUS PULSE-JET CLEANING

The TD 486's filter cartridges are cleaned automatically and continually — the system remains on-line at all times. Continuous filtration means full-time pollution control, better product quality, and longer machinery life. A mounted solid state timer controls the cycle time. Solenoid valves introduce jets of high-pressure air into each filter cartridge in turn, through the venturi opening above it. The resulting reverse air flow cleans the filter cartridges. Dust removed from the filters settles to the bottom of the collector. As each trio of cartridges is cleaned in succession, the remaining 6 continue their operation. Extremely high dust loadings are handled easily.

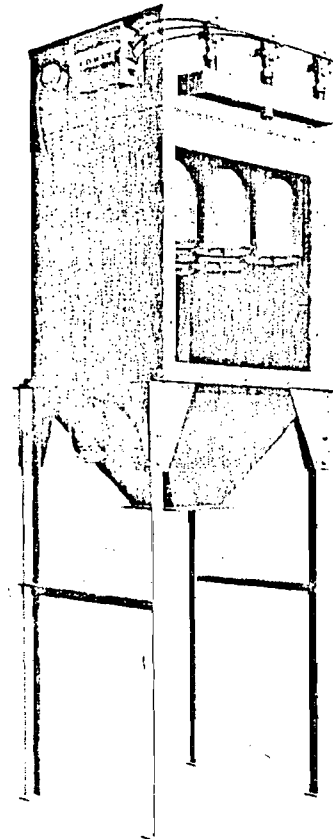

## EASY-TO-HANDLE FLEXIBILITY

The TD 486 requires up to 25% less headroom than conventional collectors — the highly efficient filter cartridges are 16" long, instead of standard 96" cloth tubes. Its compact size gives you great flexibility in location. Also, the TD 486 does the job with 9 cartridges.

The TD 486 is delivered to you in major assemblies. The system is available with different blower pack combinations for single-unit or multiple-unit applications. Its hopper can be fitted for a 55-gallon drum, or for a rotary airlock adapter. The TD is made with the same high quality TORIT puts into all its dust collection systems: air-tight all-steel construction, sealed seams, and gasketed doors and fittings. The TD 486 filter cartridge system is a major innovation in effective air pollution control, from TORIT.



# DUST COLLECTORS

FILTER-CARTRIDGE SYSTEMS/TD 486

Quick-change feature allows fast cartridge removal and installation

**BEST AVAILABLE COPY**

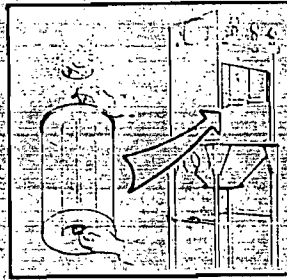
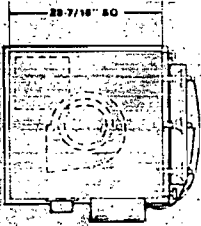

## SPECIFICATIONS

Actual Filter Area	486 sq. ft.
Number of Valves	3
Number of Filter Cartridges	9
Filter Cartridge Dimensions	7 7/8" OD x 3 1/2" ID x 16" long
Number of Hopper Outlets	1
Hopper Outlet Size	8" square
Hopper Size	3.5 cu. ft.
Shipping Weight	est. 500 lbs.
Wind Load Rating	100 m.p.h.
Seismic Rating	Zone 3
Specifications subject to change without notice.	

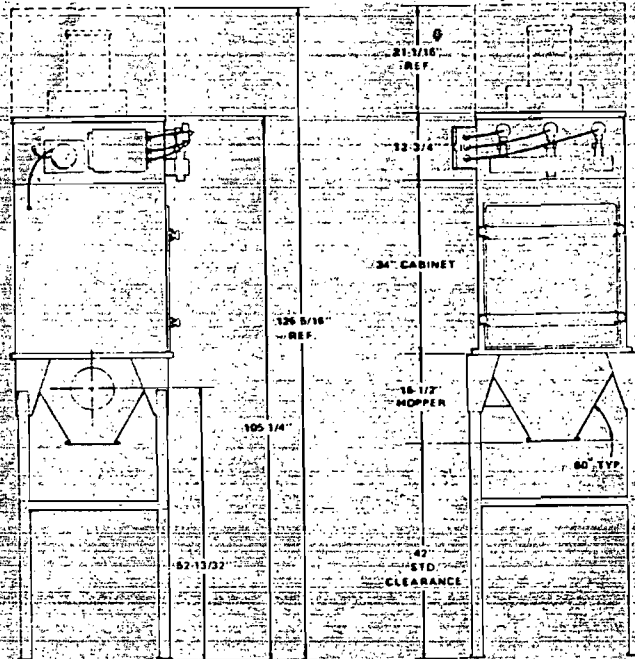

## NOTES

- Standard 7" inlet. Inlet also available with 5" and 6" ID reducers (All sides)
- Standard legs provide 42" clearance under the hopper flange. Bolt-on legs for special height requirements are available.
- TD systems must be attached to 90-100 PSIG in-plant compressed air supply for cleaning mechanism to function.
- Valves and control system operate on 120v, 60-cycle power.
- Exterior Gray is standard finish.

## PERFORMANCE TESTED

Performance ratings and A-scale sound level readings are available on each TD collector-power pack combination. These ratings are read and verified under standard test conditions in TORIT's laboratories.

## OPTIONAL EQUIPMENT

- Blower pack options include 3HP, 5HP or remote exhausters as required. Please state in-plant line voltage when ordering.
- Sound attenuator packages.
- Explosion vents.
- Rotary airlock and adapter.

SWAN-D MARK 2  
SAUDBLASTER



JOHN SWAN  
CRYSTAL  
918 240 7520

LEADERS IN CONTROL OF IN-PLANT AIR POLLUTION

Let's assume that we have one air filter and 101 spherical particles of the same density in the air. These 101 particles consist of one large, 10 micron particle and 100 small, 1 micron particles. Now let's assume that as these particles enter the filter, the one large particle is removed from the air, but the 100 smaller ones are allowed to pass through. Here is the action visually.

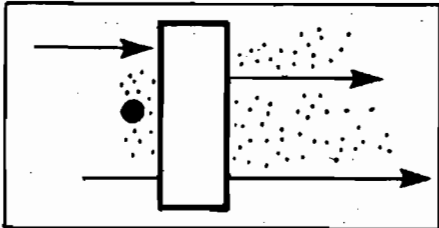

Each particle's weight can be equated to its diameter cubed. The 10 micron particle will weigh 1000 units, while the 100 one micron particles will have a total weight of 100 units. So...

## METHODS FOR EVALUATING FILTER PERFORMANCE

ASHRAE (American Society of Heating, Refrigerating, and Air-Conditioning Engineers) Standard 52-76, a recognized test standard in the air cleaner industry, defines three inter-related measurements of air cleaner performance—weight arrestance, dust-spot efficiency, and dust-holding capacity.

### WEIGHT ARRESTANCE

ASHRAE Synthetic Dust consisting of: 72% Standardized Air Cleaner Dust—Fine; 23% by weight Molocco Black; and 5% by weight No. 7 cotton linters ground in a Wiley mill with a 4mm screen is fed at 2 grams per 1000 cubic feet of air. Concentration of dust leaving the filter is determined by measuring the weight gain of a high-efficiency after filter.

$$\text{Arrestance} = 100 \times \left[ 1 - \frac{\text{weight gain of after filter}}{\text{weight of dust fed}} \right]$$

$$\left( \frac{1,000}{1,000 + 100} \right) \times 100 = 91\% \text{ ARRESTANCE} \\ \text{(Efficiency by Weight)}$$

Conclusion: Since 91% of the weight of the particles is removed, this test is meaningful if you are interested in filtering large, heavy particles.

**DONALDSON'S ULTRA-WEB™ FILTER CARTRIDGES  
PROVIDE 100% AVERAGE DUST WEIGHT ARRESTANCE!**

Each particle's staining ability can be equated to its diameter squared. Therefore, the one 10 micron particle will have a staining value of  $10^2 = 100$ . The 100 one micron particles will have a staining value of  $100 \times 1^2$  and cast a shadow equal to their total values of 100. So...

### DUST SPOT EFFICIENCY

Untreated atmospheric dust is the contaminant. Samples are drawn upstream and downstream of the filter at equal flow rates through identical targets of glass fiber filter paper. The atmospheric dust stains the target filters. The opacity of both upstream and downstream filters is measured and used to calculate the dust spot efficiency (ASHRAE efficiency).

$$\left( \frac{100}{100 + 100} \right) \times 100 = 50\% \text{ AREA EFFICIENCY}$$

Conclusion: Area relates to how much staining ability the filter eliminates. At 50% efficiency, this filter is significantly effective.

**DONALDSON'S ULTRA-WEB™ FILTER CARTRIDGES  
PROVIDE 93% AVERAGE DUST SPOT EFFICIENCY!**

## DUST HOLDING CAPACITY

This value is important when filters must be changed because of high pressure drop. A filter that holds more dust before changeout means reduced maintenance. Since the Donaldson system maintains a low filter pressure drop through automatic on line filter cleaning, this value is no longer applicable.

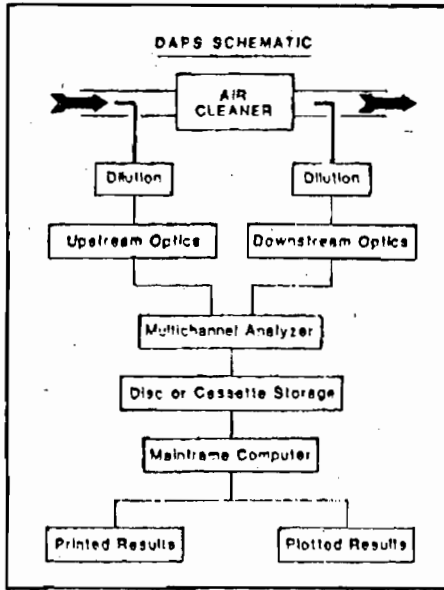

The preceding filter example illustrated efficiency determined by ASHRAE 52-76 test methods. Using the same example, the particle count efficiency reveals a very low filtration efficiency. Example: on a count basis the ratio of particles is 100—1. So...

## COUNT EFFICIENCY

The most stringent filter efficiency test method relies on the actual number of dust particles passing through the filter. Sophisticated data acquisition and processing equipment reduce the task to routine laboratory procedures at Donaldson.

Recent advances in optical and computer technology have made it possible to obtain quantitative data on initial efficiency and fractional efficiency. Fractional efficiency is the efficiency, on a particle count basis, of discrete particle size intervals. When these values are plotted (see Fractional Efficiency Graph, page 5.1.7) a fractional efficiency curve is generated. It is now possible to continuously monitor the amount and size of dust particles penetrating an air filter throughout the test. This information is shedding new light on air filter design and application and is allowing better judgment when deciding on optimum configuration for various applications.

The Donaldson Airborne Particle System (DAPS) shown schematically at the left, can be used to test filter media in the flat sheet or to test an air filter. Provisions are made for isokinetic sampling upstream and downstream of the filter and for dilution of the sample (if necessary) before it reaches the optics. Dilution involves mixing the sample with clean air to limit the particle concentration entering the optics.

The optical detectors form an intense light on a small volume through which the particles must pass. As they pass through light is scattered in several directions. The scattered light is collected by an elliptical mirror and focused on a photomultiplier tube. The amplitude of the photomultiplier output is proportional to the size of the particle. Several particles in the volume at the same time would cause what is called coincidence error. This is the reason for dilution of the sample.

The photomultiplier output goes to a multichannel analyzer (MCA) which counts the particles in each of 1024 different size ranges. The MCA accumulates particle counts for a predetermined period of time. At the end of each time increment the accumulated data are stored on magnetic disk or tape for later processing and the acquisition starts over again.

$$\left( \frac{1}{1 + 100} \right) \times 100 = 0.99\% \text{ COUNT EFFICIENCY}$$

Conclusion: Count efficiency illustrates a filter's ability to remove contaminants throughout a complete size distribution.

**ULTRA-WEB™ IS EVALUATED BASED ON COUNT EFFICIENCY. SINCE ULTRA-WEB™ IS INVISIBLE TO THE NAKED EYE, A COUNT EFFICIENCY TEST SYSTEM WAS INSTALLED IN THE DONALDSON PRODUCTION FACILITY TO ENSURE PROCESS SPECIFICATIONS ARE MAINTAINED.**



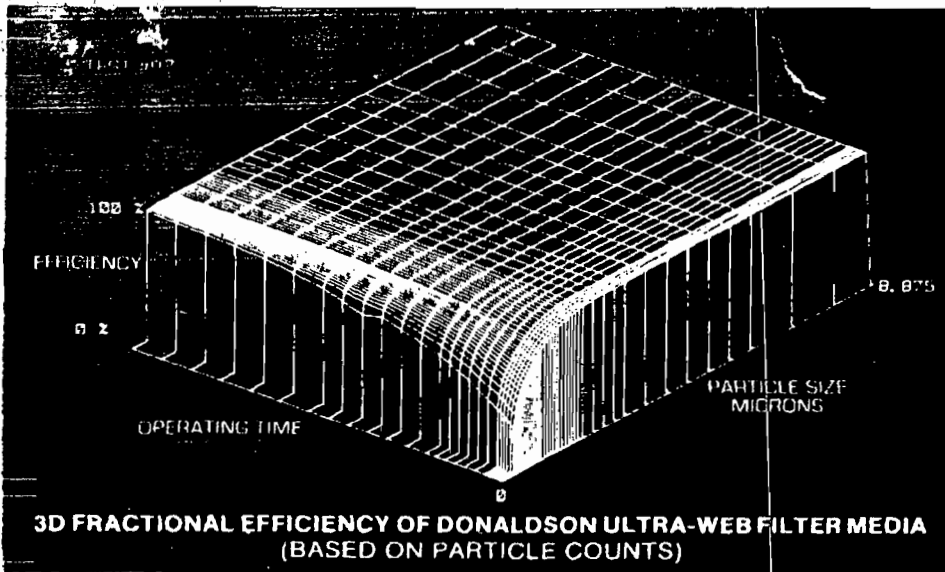

Fractional efficiency can be easily visualized using a 3-dimensional graph. Operating time is plotted against particle size. This graph illustrates increasing efficiency as the dust cake is building with increased operating time. Overall Ultra-Web media efficiency can reach 99.99% after a stable dust cake has been developed. Under normal operating conditions extremely high efficiencies are reached within days of initial start-up.

### FILTER DETAILS/DIMENSIONS

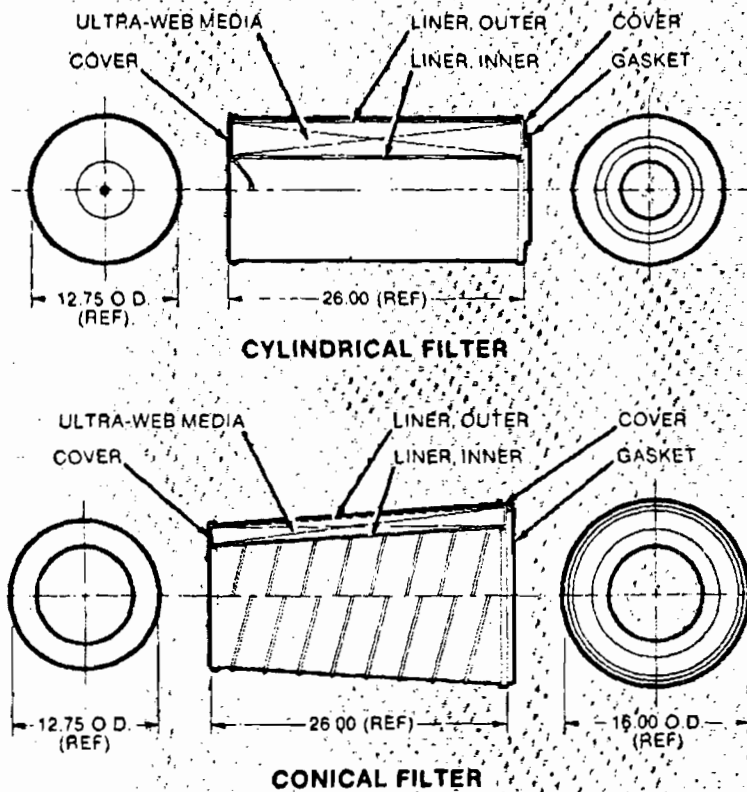

### FILTER PRESSURE DROP

Equipment design often revolves around determining the total resistance to moving air through the system. With clean filters the accompanying curve can be used to assist in determining operating static pressure.

**NOTE:** With an automatic pulse cleaned system add 1.5-2.0 in. w.g. to the initial filter pressure drop to arrive at a stable operating design condition.

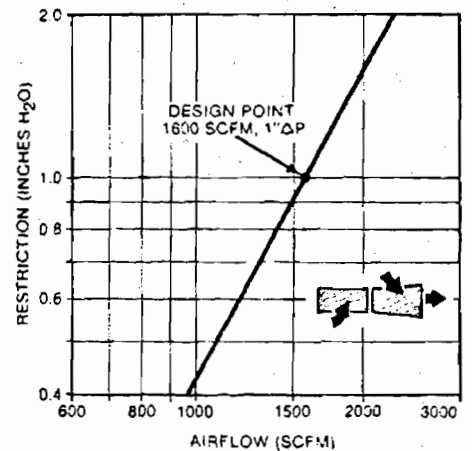

**FILTER RESTRICTION** (ONE PAIR OF CONICAL/CYLINDRICAL FILTERS)



# HIERIDATA

TYPICAL AMBIENT  
AEROSOL

100X

600X

CLEAN  
FILTERED  
AIR

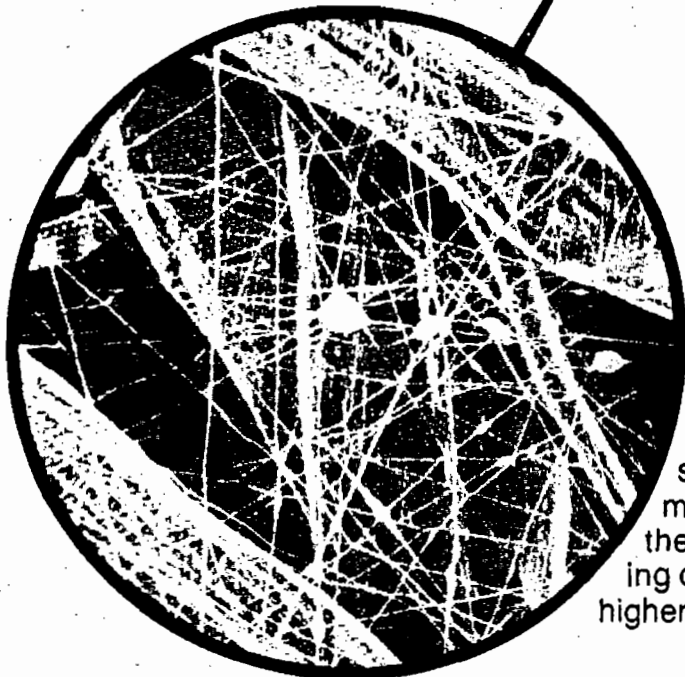

Microscopic view of Ultra-Web  
at 600X magnification

Donaldson's exclusive **Ultra-Web™** filter media is standard in all our ambient air filtration and ventilation systems.

Ultra-Web is produced through a proprietary process in which a surface treatment of microscopic fibers is applied to the conventional media substrate. This allows even extremely small dust particles to be collected on the outer surface of the media, rather than penetrating and becoming trapped within the media. This performance characteristic minimizes blinding of the media and leads to operating advantages including higher filtration efficiency, lower system costs, and longer filter life.

Field tests have shown that Ultra-Web is particularly advantageous for filtering extremely small particles in large air volumes.

Ultra-Web cartridges are competitively priced, especially on the basis of total life-cycle system costs compared to conventional cartridges.

### Ultra-Web™ DESCRIPTION

When Donaldson Company, Inc. designed Ultra-Web, filter media engineers theoretically analyzed media concepts that would produce the ultimate filter performance. The process took nearly ten years to perfect, and the result is impressive.

A primary self-cleaning media performance criteria is matching the media structure (inter-fiber space) with the size of the contaminant to be filtered. This consideration determines the dust cake architecture and media cleanability. After initial system start-up and seasoning, a self-cleaning system operates with the dust cake providing the predominant filtration structure. The cleaning operation should remove enough of the dust cake to reduce the pressure drop to satisfactory steady state levels. Optimized self-cleaning media performance will then require the efficient capture of particles in a surface location that allows for easy removal to obtain the desired steady state system pressure drop.

Particle size is a key filtration performance criteria since the mechanisms of particle collection are strong functions of particle diameter. For small particles less than one micron, collection is achieved by diffusion and direct interception, while for particles greater than one micron, direct interception and inertial deposition dominate. Conventional filtration media use large fiber diameters with corresponding large inter-fiber spaces. For conventional media, during system start-up, immediately after cleaning and throughout much of the cake building mode, particles less than one micron in diameter are collected in the depth of the media. Depth collection results in short system life, since particles cannot be easily removed from the depth of the media. Media cleanability requires a cake structure that can be fractured and removed in large agglomerates. Conventional filter materials have inter-fiber spaces larger than 20-60 microns. Therefore, in general, contaminants significantly

smaller than the inter-fiber space can and will penetrate into the media causing inefficient cleaning and short system life between bag or cartridge replacements. The smaller the contaminant, the greater the problem.

Ultra-Web media was developed to address the aforementioned problems of using conventional filter media for small particles. Ultra-Web uses sub-micron diameter fibers at low solidity and layer thickness providing small inter-fiber spaces and negligible pressure drop. Ultra-Web is pictured schematically as:

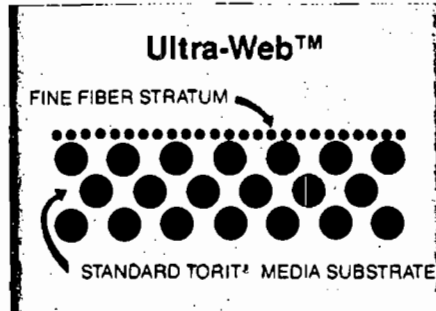

illustrating a tight surface structure of sub-micron fibers bonded to a more open substrate. The submicron fibers provide the foundation for surface cake filtration and minimize penetration of submicron particles, while the substrate provides physical structure and support for the fine fiber layer and dust cake. During initial system start-up and immediately after cleaning, the fine fiber layer collects particles by diffusion and direct interception on the media surface. The fine fiber layer is only 1 or 2 microns thick. The initial efficiency of Ultra-Web is up to 10 times greater than conventional filter media at the same conditions. The high initial efficiency of Ultra-Web on submicron particles yields a fast surface cake build-up which minimizes seasoning time and media bleed through. The surface cake created by the fine fiber layer yields a cake structure that is easily and efficiently removed during cleaning cycles.

Ultra-Web is a surface loading media that minimizes depth penetration and maximizes system throughput at low pressure drop. It provides high levels of efficiency extending to submicron particle diameters ideally suited for ventilation systems.

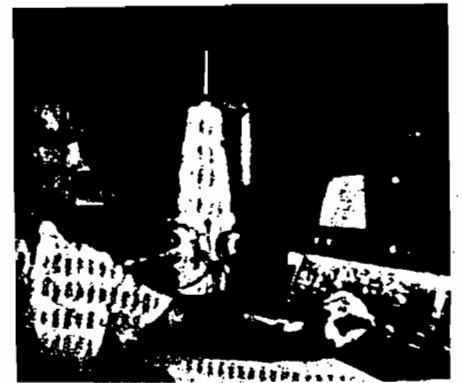

Sophisticated laboratory equipment such as this scanning electron microscope is helping Donaldson researchers probe deep into the nature of particles.

*Take a look through the microscope at Ultra-Web™!*

Ultra-Web utilizes a layer of fine fibers applied to a substrate of standard filter cartridge media. The depth of the fine fiber layer is 100 to 200 times less than that of the substrate. The space between the fibers is up to 100 times smaller than that of the substrate fibers. Therefore, nearly all particles are caught on the surface of the media and depth loading is minimized.

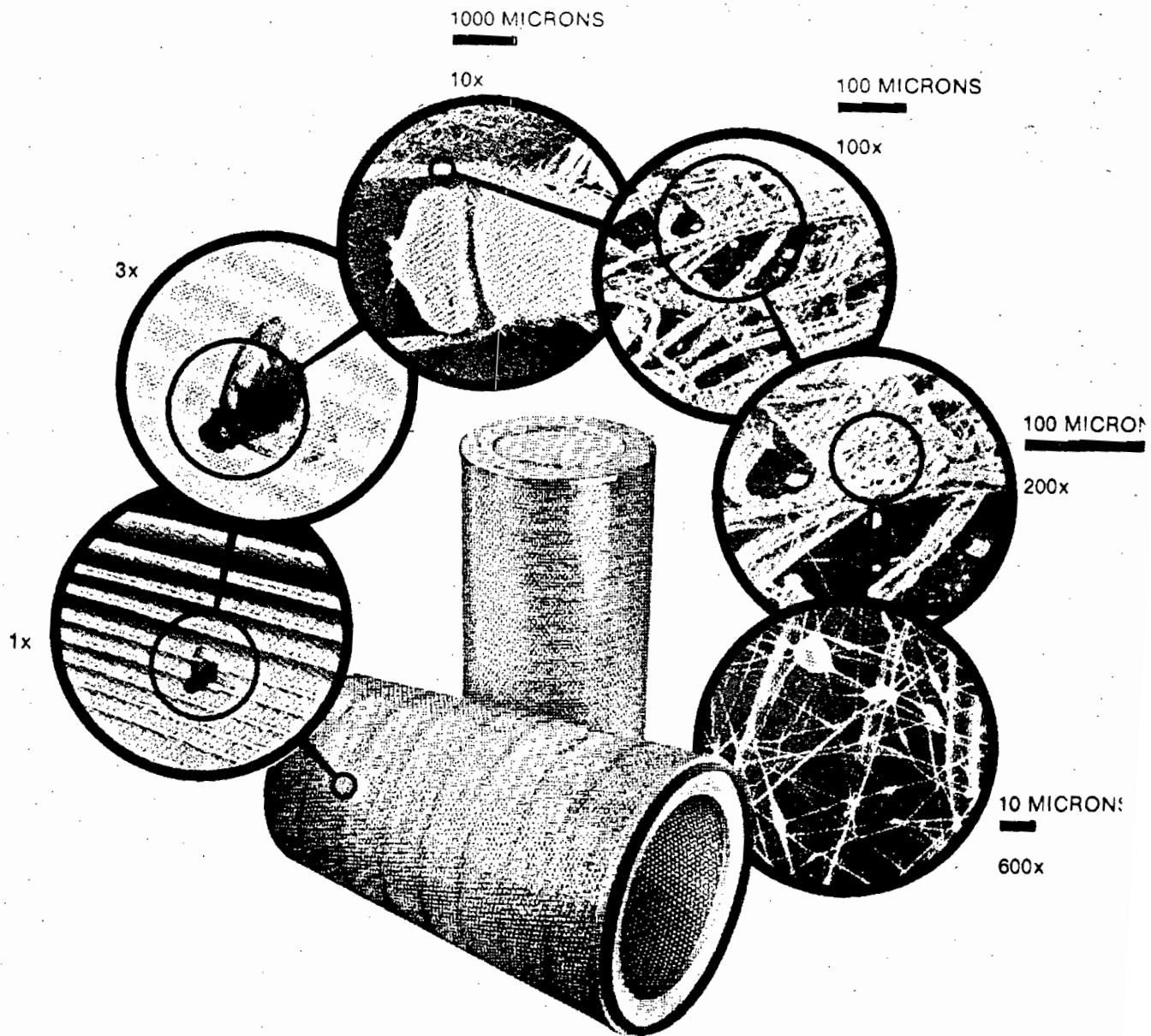

**Compare Ultra-Web™ to other filter media!**

**Polyester felt** is used to form a very thick filter media—between 1/8 and 1/2 inch in depth—used for filter bags in continuous-duty dust collectors. The fibers are approximately 25 to 60 microns apart. Many particles not caught on the surface of the media are caught inside, since the particles must follow a long tortuous path to get through the felt. Because of this "depth loading", polyester felt filters require a large amount of energy to pulse the entrained particles out of the media. Failure to thoroughly clean the media results in high pressure drop. Smaller particles may penetrate the media, especially during the period immediately following the pulse cleaning operation.

**Fluoroplastic Membrane**

Fluoroplastic membranes are typically laminated on the surface of conventional filter medias such as polyester felt. The membrane provides a dense mat of submicron surface fibers. Since the membrane is generated by processing a solid sheet of fluoroplastic, it has a relatively high solidity and layer thickness. The high solidity creates resistance to airflow and a corresponding increased filter pressure drop above the supporting substrate.

Fluoroplastics provide advantages over other materials in aggressive chemical environments as well as elevated temperatures.

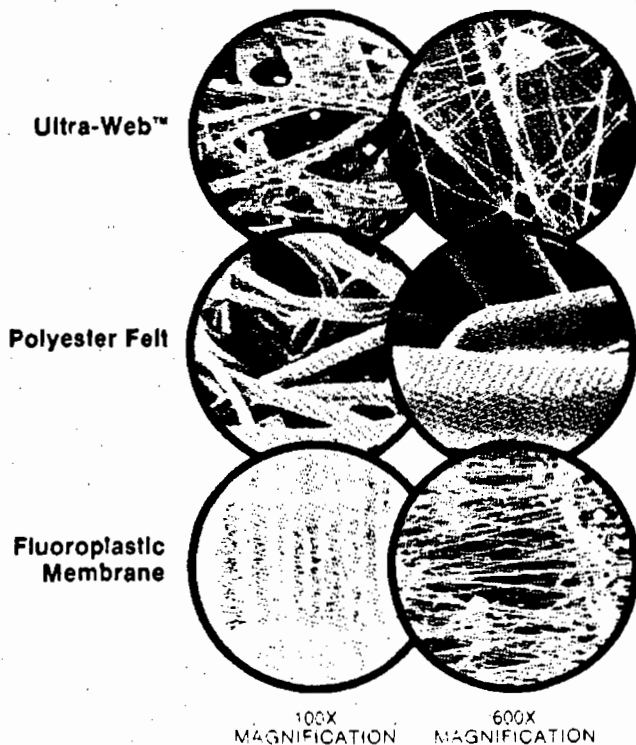

**Ultra-Web = Better Cleaning**

Better surface loading results in easier particle release during the cleaning cycle and minimizes the restriction of air flow at design conditions.

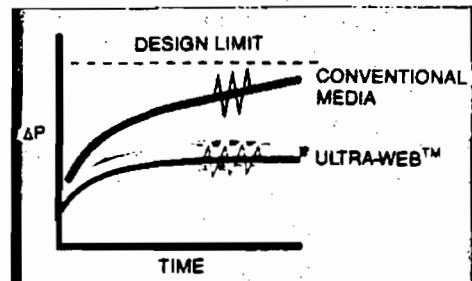

**Ultra-Web = Lower Energy Costs**

Electricity is a significant cost to be considered in the operation of any ventilation system. Since system costs vary directly with pressure drop and flow rate, the advantages of Ultra-Web translate directly into energy savings of 25 percent or more.

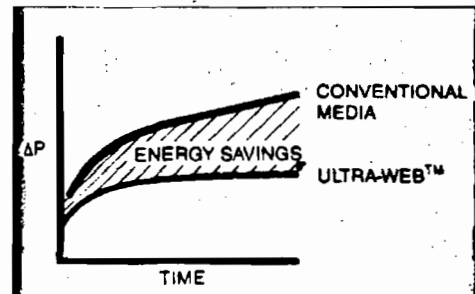

# PROCESS FLOW DIAGRAM ABRADING MACHINE WITH DUST COLLECTOR SYSTEM

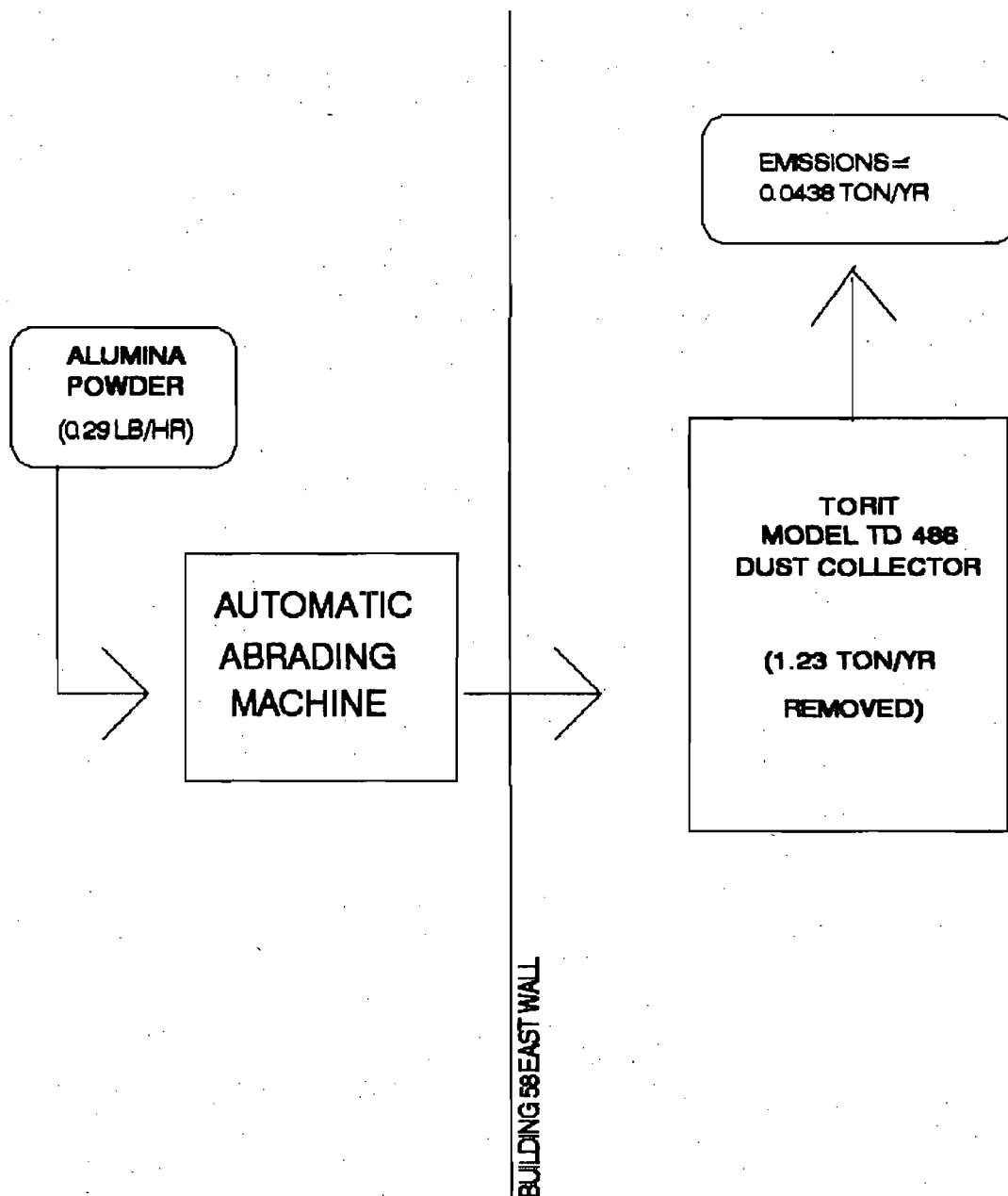

HARRIS SEMICONDUCTOR

-- AIR PERMIT INFORMATION

CURRENT PERMIT

-----  
BUILDING: 58  
PERMIT NUMBER: AC 05-104521  
PERMIT TYPE : CONSTRUCTION

DATE ISSUED : 01/15/86  
RENEWAL DATE: 04/01/86  
DATE EXPIRES: 06/30/86

AREA SERVED:  
PROCESS DESCRIPTION: CHEMICAL VAPOR SCRUBBER

PERMIT LIMITS

-----  
VOL. RATE (SCFM): 12.500  
ACID MIST (LB/HR): <0.0002  
SOLVENTS (LB/HR): 0.1672  
VOCS (LB/HR): --  
OPER. (HRS/YEAR): 2112

SPECIFIC CONDITIONS

-----  
ANNUAL OPERATING REPORT :  
NOTIFICATION OF VE TEST :  
ANNUAL VIS EMISSION TEST:

EQUIPMENT INFORMATION

-----  
MANUFACTURER : TRI-MER CORP.  
LOCATION : B58 ROOF WESTSIDE  
HARRIS ID NUMBER : F58S01  
VOLUME FLOW RATE (CFM): 12.500  
RECIRCULATION RATE (GPM): 40  
MAKEUP WATER RATE (GPM): 2.0

MODEL NUMBER : F/W 5  
STACK HEIGHT (FT): 12  
STACK DIAMETER (IN): 27  
STACK VELOCITY (FPM):  
DUCT MATERIAL :

PERMIT HISTORY

-----  
PERMIT NUMBER: AC 05-104521  
DATE EXPIRED : 06/30/86

PERMIT NUMBER:  
DATE EXPIRED :

PERMIT NUMBER:  
DATE EXPIRED :

SCRUBBER INFORMATION

HARRIS ID # : F58S01  
MANUFACTURER : TRI-MER CORP. MODEL NUMBER : F/W 5  
SERIAL NUMBER: 7031 MATERIAL : PVC  
DESCRIPTION : HORIZONTAL COUNTER-FLOW, MIST ELIMINATOR  
WHITE POLYPRO FILTER PACK, DWG. 1000-667 (1/81)

DESIGN DATA

VOLUME FLOW RATE (CFM): 14.000 PRESSURE DROP (IN):  
RECIRCULATION RATE (GPM): 40 MAKE UP RATE (GPM): 2.0

ACTUAL DATA

VOLUME FLOW RATE (CFM): 10.386 PRESSURE DROP (IN): DATE: 12/17/86  
RECIRCULATION RATE (GPM): 40 MAKE UP RATE (GPM): 2 DATE: 01/16/87

RECIRCULATION PUMP INFORMATION

MANUFACTURER : FLOTEC MODEL NUMBER : C7P8-1194V  
SERIAL NUMBER: HP : 1 RPM : 3450  
BRKR LOCATION: NEXT TO UNIT FED FROM MCC : PP 28

FAN INFORMATION

HARRIS ID # : F58E11  
MANUFACTURER : TRI-MER CORP. MODEL NUMBER: 30 UB  
SERIAL NUMBER: 5407 MATERIAL : PVC  
DESCRIPTION : CENTRIFUGAL BLOWER. BACKWARD INCLINED BLADES

DESIGN DATA

VOLUME FLOW RATE (CFM): 12.500 STATIC PRESS (IN): 4"

ACTUAL DATA

VOLUME FLOW RATE (CFM): 10.386 SPEED (RPM): DATE:  
STATIC PRESS (IN): DATE: 12/17/86

FAN MOTOR INFORMATION

MANUFACTURER : LINCOLN TEFC MODEL NUMBER : FRAME 256  
SERIAL NUMBER: N/A HP : 20 RPM : 1750  
BRKR LOCATION: NEXT TO UNIT FED FROM MCC : PP 28

Attachment :

HARRIS SEMICONDUCTOR -- AIR PERMIT INFORMATION

CURRENT PERMIT

BUILDING: 58 DATE ISSUED : 01/15/86  
PERMIT NUMBER: AC 05-104527 RENEWAL DATE: 04/01/86  
PERMIT TYPE : CONSTRUCTION DATE EXPIRES: 06/30/86

AREA SERVED:  
PROCESS DESCRIPTION: VOC/SOLVENT SCRUBBER

PERMIT LIMITS

VOL. RATE (SCFM): 3.000  
ACID MIST (LB/HR): --  
SOLVENTS (LB/HR): 0.002  
VOCS (LB/HR): --  
OPER. (HRS/YEAR): 2112

SPECIFIC CONDITIONS

ANNUAL OPERATING REPORT :  
NOTIFICATION OF VE TEST :  
ANNUAL VIS EMISSION TEST:

EQUIPMENT INFORMATION

MANUFACTURER : HARRISON MODEL NUMBER : HF-30  
LOCATION : B58A ROOF NORTHWEST SIDE  
HARRIS ID NUMBER : F58S02 STACK HEIGHT (FT): 6  
VOLUME FLOW RATE (CFM): 3,000 STACK DIAMETER (IN): 12  
RECIRCULATION RATE (GPM): 20 STACK VELOCITY (FPM):  
MAKEUP WATER RATE (GPM): 2.0 DUCT MATERIAL :

PERMIT HISTORY

PERMIT NUMBER: AC 05-104527  
DATE EXPIRED : 06/30/86

PERMIT NUMBER:  
DATE EXPIRED :

PERMIT NUMBER:  
DATE EXPIRED :



SCRUBBER INFORMATION

HARRIS ID # : F58S02  
MANUFACTURER : HARRISON MODEL NUMBER : HF-30  
SERIAL NUMBER: N/A MATERIAL : POLYPRO  
DESCRIPTION : HORIZONTAL CROSS-FLOW, PLASTIC SADDLE PACKING, LIQUID  
DISTRIBUTION THROUGH MAIN HEADER, NO SPRAY NOZZLES,  
DWG HPS 402H

DESIGN DATA

VOLUME FLOW RATE (CFM): 3,000 PRESSURE DROP (IN):  
RECIRCULATION RATE (GPM): 20 MAKE UP RATE (GPM): 2.0

ACTUAL DATA

VOLUME FLOW RATE (CFM): 2,275 PRESSURE DROP (IN): DATE: 12/18/86  
RECIRCULATION RATE (GPM): 20 MAKE UP RATE (GPM): 2 DATE: 01/16/87

RECIRCULATION PUMP INFORMATION

MANUFACTURER : FILTER PUMP IND. MODEL NUMBER : 110217-00  
SERIAL NUMBER: HP : 3/4 RPM : 3450/2850  
BRKR LOCATION: FED FROM MCC :

FAN INFORMATION

HARRIS ID # : F58E13  
MANUFACTURER : HARTZELL MODEL NUMBER: 41-15-GL3  
SERIAL NUMBER: 51059 MATERIAL : FIBERGLASS  
DESCRIPTION : CENTRIFUGAL BLOWER. BACKWARD CURVED BLADES

DESIGN DATA

VOLUME FLOW RATE (CFM): 3.000 STATIC PRESS (IN):

ACTUAL DATA

VOLUME FLOW RATE (CFM): 2.275 SPEED (RPM): DATE:  
STATIC PRESS (IN): DATE: 12/18/86

FAN MOTOR INFORMATION

MANUFACTURER : MODEL NUMBER :  
SERIAL NUMBER: HP : 5 RPM : 1725  
BRKR LOCATION: FED FROM MCC :

*HARRIS SEMICONDUCTOR*  
*AIR PERMIT - BUILDING 58*  
*ATTACHMENT E*  
*SITE LOCATION MAPS*

HARRIS SEMICONDUCTOR  
 SCRUBBER LOCATIONS  
 BUILDING 58

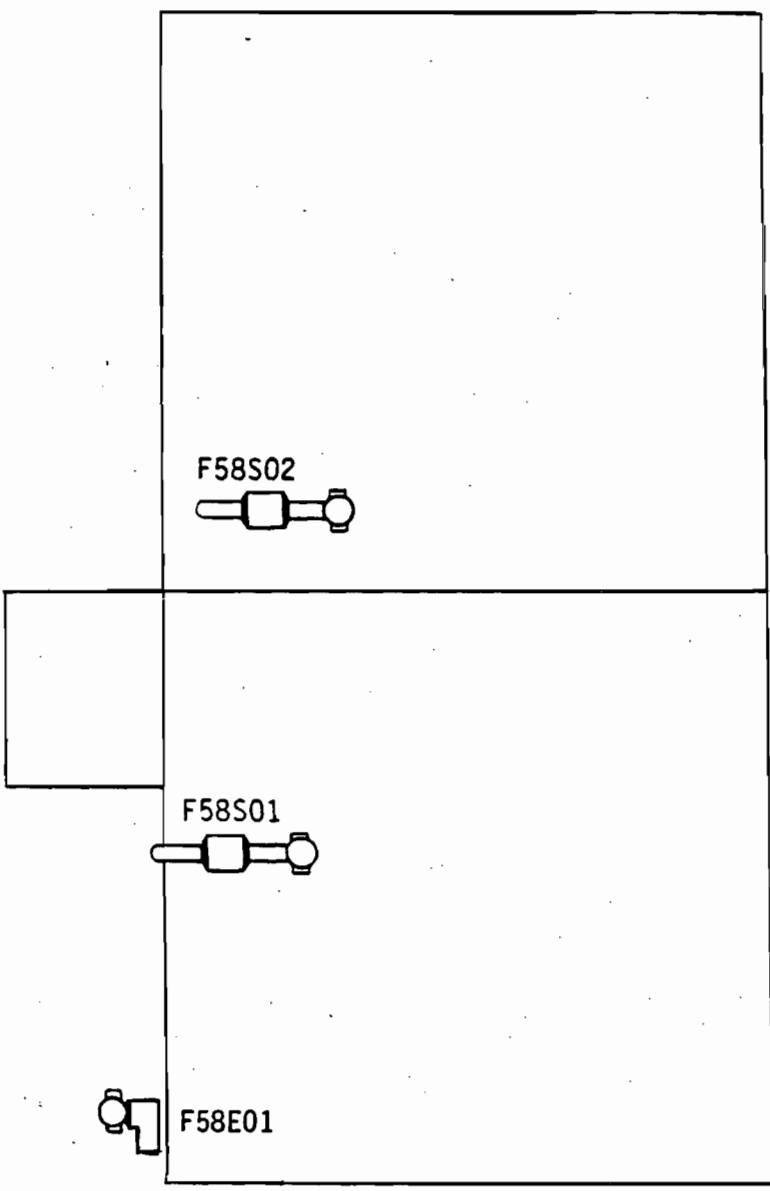
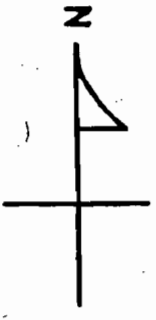

Torit  
 Dust Collector

LEGEND

- Horizontal Scrubber
- Vertical Scrubber
- Exhaust Stack
- Exhaust Fan
- Stack mounted on fan
- Epitaxial Scrubber

APOLLO BLVD

# Harris Semiconductor Complex

SCRUBBER LOCATIONS

POND

F62S02  
F62S01

62B 62A

PARKING LOT  
F58S02  
F58S01

PARKING LOT

59

F57S01

58

PARKING LOT

POND

F59S01  
F59S03

63

F63S02  
F63S01  
F63S03

F54S03  
F54S04  
F54S01  
F54S02  
F60S01  
F55S01

54

PARKING LOT

F04S05  
F04S06  
F04S01

60

53

PARKING LOT

BORROW PIT

56

55

52

51

PARKING

4

6

TROUTMAN

F51S01  
F51S02  
F51S03  
F51S04  
F51S05

F04S08  
F04S04  
F04S03  
F04S02

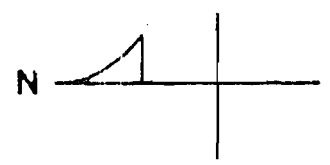

F61S02  
F61S01

61

PARKING LOT

LIPSCOMB ST

PALM BAY BLVD



December 6, 1988

1031

Mr. C.H. Fancy, P.E.  
Deputy Bureau Chief  
State of Florida  
Department of Environmental Regulation  
Bureau of Air Quality Management  
2600 Blair Stone Road  
Tallahassee, Florida 32301

Subject: Harris Semiconductor  
Building 63 Consolidated Air Permit

Dear Mr. Fancy:

On February 17, 1988 representatives from Harris and the Florida DER met in Orlando to discuss the status of air permits at Harris Semiconductor's facility in Palm Bay. At that meeting it was agreed that Harris would submit modified air permits for all existing emission points. The purpose of the permit modifications was as follows:

1. Consolidate permits on a by building basis to reduce the existing number of permits.
2. To accurately quantify the current air emissions from the facility.

Enclosed is the original and two (2) copies of the modified permit application for Semiconductor's Building 63.

If you should have any questions about the enclosed information, please feel free to contact me at (407) 724-7467.

Sincerely,

J.R. Kolanek, Manager  
Environmental Services

1031

Enclosure

cc: C. Collins  
Central Florida District

RECEIVED  
DER - MAIL ROOM  
1988 DEC -9 AM 10:53

THE FIRST NATIONAL BANK OF ATLANTA  
AUGUSTA, GA

**HARRIS** 00178 64-1327 623697

HARRIS CORPORATION  
SEMICONDUCTOR GROUP

PAY \*\*\*\*\*100 DOLLARS AND 00 \*\*\*\*\*CENTS \*\*\*\*\*100.00\*\*\*\*\*

CHECK AMOUNT

ACCT. NO. PAYABLE DATE  
CHECK NUMBER

TO ORDER OF

FLORIDA DEPARTMENT OF ENVIRONMENTAL REGULATION  
2600 BLAIR STONE ROAD  
TALLAHASSEE, FL 32399-2400

HARRIS SEMICONDUCTOR

COUNTERSIGNED

AUTHORIZED SIGNATURE

[Redacted Signature]

[Redacted Address]

Consolidated Air Permit

1031

**HARRIS**  
HARRIS CORPORATION  
SEMICONDUCTOR SECTOR

THE FIRST NATIONAL BANK OF ATLANTA  
AUGUSTA, GEORGIA

00178 64-1327 611

046301

DATE	CHECK NO.	NET AMOUNT
10/28/88	00046301	*****100.00

HUNDRED AND 00/100 DOLLARS

TO THE ORDER OF  
DEPT OF ENVIRONMENT REGULATION  
2600 BLAIR STONE ROAD  
TALLAHASSEE, FLA

HARRIS CORPORATION  
SEMICONDUCTOR SECTOR

32399

COUNTERSIGNED  
[Signature]  
AUTHORIZED SIGNATURE

Sincerely,  
*James R. Kolanek*  
J.R. Kolanek, Manager  
Environmental Services

Enclosure

cc: C. Collins  
Central Florida District

1988 DEC -9 AM 10:53  
RECEIVED  
PER-MAIL ROOM

# DEPARTMENT OF ENVIRONMENTAL REGULATION

WIN TOWERS OFFICE BUILDING  
2600 BLAIR STONE ROAD  
TALLAHASSEE, FLORIDA 32301-8241

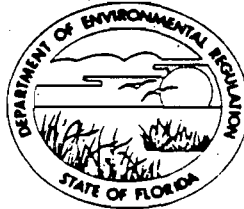

AC 05-158237

BOB GRAHAM  
GOVERNOR

VICTORIA J. TSCHINKEL  
SECRETARY

## APPLICATION TO OPERATE/CONSTRUCT AIR POLLUTION SOURCES

SOURCE TYPE: Stationary [ ] New<sup>1</sup> [X] Existing<sup>1</sup>  
APPLICATION TYPE: [ ] Construction [ ] Operation [X] Modification  
COMPANY NAME: Harris Semiconductor COUNTY: Brevard  
Identify the specific emission point source(s) addressed in this application (i.e. Lime  
Kila No. 4 with Venturi Scrubber; Peaking Unit No. 2, Gas Fired) \_\_\_\_\_  
SOURCE LOCATION: Street Palm Bay Road City Palm Bay  
UTM: East 17-538700 North 17-3100900  
Latitude 28 ° 01 ' 20 "N Longitude 80 ° 36 ' 10 "W  
APPLICANT NAME AND TITLE: J. R. Kolanek; Manager Environmental Services  
APPLICANT ADDRESS: P.O. Box 883, Melbourne, FL 32901

### SECTION I: STATEMENTS BY APPLICANT AND ENGINEER

#### A. APPLICANT

I am the undersigned owner or authorized representative\* of Harris Semiconductor

I certify that the statements made in this application for a modified permit are true, correct and complete to the best of my knowledge and belief. Further, I agree to maintain and operate the pollution control source and pollution control facilities in such a manner as to comply with the provision of Chapter 403, Florida Statutes, and all the rules and regulations of the department and revisions thereof. I also understand that a permit, if granted by the department, will be non-transferable and I will promptly notify the department upon sale or legal transfer of the permitted establishment.

\*Attach letter of authorization

Signed: *J. R. Kolanek*  
J. R. Kolanek, Manager, Environmental Svcs.  
Name and Title (Please Type)

Date: 12/5/88 Telephone No. (407) 724-7467

#### B. PROFESSIONAL ENGINEER REGISTERED IN FLORIDA (where required by Chapter 471, F.S.)

This is to certify that the engineering features of this pollution control project have been designed/examined by me and found to be in conformity with modern engineering principles applicable to the treatment and disposal of pollutants characterized in the permit application. There is reasonable assurance, in my professional judgment, that

<sup>1</sup> See Florida Administrative Code Rule 17-2.100(57) and (104)

the pollution control facilities, when properly maintained and operated, will discharge an effluent that complies with all applicable statutes of the State of Florida and the rules and regulations of the department. It is also agreed that the undersigned will furnish, if authorized by the owner, the applicant a set of instructions for the proper maintenance and operation of the pollution control facilities and, if applicable, pollution sources.

Signed Lawrence R. Hutker

Lawrence R. Hutker

Name (Please Type)

Harris Semiconductor

Company Name (Please Type)

P.O. Box 883, Melbourne, Florida 32901

Mailing Address (Please Type)

Florida Registration No. 35972 Date: 12/5/88 Telephone No. (407) 729-4655

**SECTION II: GENERAL PROJECT INFORMATION**

- Describe the nature and extent of the project. Refer to pollution control equipment, and expected improvements in source performance as a result of installation. State whether the project will result in full compliance. Attach additional sheet if necessary.

This is a modification and consolidation of existing air permits.

- Schedule of project covered in this application (Construction Permit Application Only)

Start of Construction N/A Completion of Construction \_\_\_\_\_

- Costs of pollution control system(s): (Note: Show breakdown of estimated costs only for individual components/units of the project serving pollution control purposes. Information on actual costs shall be furnished with the application for operation permit.)

N/A

- Indicate any previous DER permits, orders and notices associated with the emission point, including permit issuance and expiration dates.

A005-121930 issued 9/16/86; expires 9/14/91

AC05-104512 issued 1/14/86; expires 6/30/86

AC05-108260 issued 2/28/86; expires 6/30/86



E. Requested permitted equipment operating time: hrs/day 24 ; days/wk 7 ; wks/yr 52 ;  
if power plant, hrs/yr \_\_\_\_\_ ; if seasonal, describe: \_\_\_\_\_  
\_\_\_\_\_  
\_\_\_\_\_

F. If this is a new source or major modification, answer the following questions.  
(Yes or No)

1. Is this source in a non-attainment area for a particular pollutant? No  
a. If yes, has "offset" been applied? \_\_\_\_\_  
b. If yes, has "Lowest Achievable Emission Rate" been applied? \_\_\_\_\_  
c. If yes, list non-attainment pollutants. \_\_\_\_\_

2. Does best available control technology (BACT) apply to this source?  
If yes, see Section VI. No

3. Does the State "Prevention of Significant Deterioration" (PSD)  
requirement apply to this source? If yes, see Sections VI and VII. No

4. Do "Standards of Performance for New Stationary Sources" (NSPS)  
apply to this source? No

5. Do "National Emission Standards for Hazardous Air Pollutants"  
(NESHAP) apply to this source? No

H. Do "Reasonably Available Control Technology" (RACT) requirements apply  
to this source? No

a. If yes, for what pollutants? \_\_\_\_\_

b. If yes, in addition to the information required in this form,  
any information requested in Rule 17-2.650 must be submitted.

Attach all supportive information related to any answer of "Yes". Attach any justifi-  
cation for any answer of "No" that might be considered questionable.

SECTION III: AIR POLLUTION SOURCES & CONTROL DEVICES (Other than Incinerators)

A. Raw Materials and Chemicals Used in your Process, if applicable:

Description	Contaminants		Utilization Rate - lbs/hr	Relate to Flow Diagram
	Type	% wt		
---SEE ATTACHMENT C ---				

B. Process Rates, if applicable: (See Section V, Item 1)

1. Total Process Input Rate (lbs/hr): not applicable

2. Product Weight (lbs/hr): not applicable

C. Airborne Contaminants Emitted: (Information in this table must be submitted for each emission point, use additional sheets as necessary)

Name of Contaminant	Emission <sup>1</sup>		Allowed <sup>2</sup> Emission Rate per Rule 17-2	Allowable <sup>3</sup> Emission lbs/hr	Potential <sup>4</sup> Emission		Relate to Flow Diagram
	Maximum lbs/hr	Actual T/yr			lbs/yr	T/yr	
---SEE ATTACHMENT B ---							

<sup>1</sup>See Section V, Item 2.

<sup>2</sup>Reference applicable emission standards and units (e.g. Rule 17-2.600(5)(b)2. Table II, E. (1) - 0.1 pounds per million BTU heat input)

<sup>3</sup>Calculated from operating rate and applicable standard.

<sup>4</sup>Emission, if source operated without control (See Section V, Item 3).

J. Control Devices: (See Section V, Item 4)

Name and Type (Model & Serial No.)	Contaminant	Efficiency	Range of Particles Size Collected (in microns) (If applicable)	Basis for Efficiency (Section V Item 5)
---SEE ATTACHMENT D ---				

E. Fuels

Type (Be Specific)	Consumption*		Maximum Heat Input (MMBTU/hr)
	avg/hr	max./hr	

\*Units: Natural Gas--MMCF/hr; Fuel Oils--gallons/hr; Coal, wood, refuse, other--lbs/hr.

Fuel Analysis:

Percent Sulfur: \_\_\_\_\_ Percent Ash: \_\_\_\_\_

Density: \_\_\_\_\_ lbs/gal Typical Percent Nitrogen: \_\_\_\_\_

Heat Capacity: \_\_\_\_\_ BTU/lb \_\_\_\_\_ BTU/gal

Other Fuel Contaminants (which may cause air pollution): \_\_\_\_\_

F. If applicable, indicate the percent of fuel used for space heating.

Annual Average \_\_\_\_\_ Maximum \_\_\_\_\_

G. Indicate liquid or solid wastes generated and method of disposal.

Waste water from air scrubbers is discharged to on-site Waste Water Treatment  
Plant--discharge to deepwell under UIC - Permit #UC05-126519.

-----SEE ATTACHMENT D-----

H. Emission Stack Geometry and Flow Characteristics (Provide data for each stack):

Stack Height: \_\_\_\_\_ ft. Stack Diameter: \_\_\_\_\_ ft.  
 Gas Flow Rate: \_\_\_\_\_ ACFM \_\_\_\_\_ DSCFM Gas Exit Temperature: \_\_\_\_\_ °F.  
 Water Vapor Content: \_\_\_\_\_ % Velocity: \_\_\_\_\_ FPS

**SECTION IV: INCINERATOR INFORMATION**  
 not applicable

Type of Waste	Type 0 (Plastics)	Type I (Rubbish)	Type II (Refuse)	Type III (Garbage)	Type IV (Pathological)	Type V (Liq. & Gas By-prod.)	Type VI (Solid By-prod.)
Actual lb/hr Incinerated							
Uncontrolled (lbs/hr)							

Description of Waste \_\_\_\_\_  
 Total Weight Incinerated (lbs/hr) \_\_\_\_\_ Design Capacity (lbs/hr) \_\_\_\_\_  
 Approximate Number of Hours of Operation per day \_\_\_\_\_ day/wk \_\_\_\_\_ wks/yr. \_\_\_\_\_  
 Manufacturer \_\_\_\_\_  
 Date Constructed \_\_\_\_\_ Model No. \_\_\_\_\_

	Volume (ft) <sup>3</sup>	Heat Release (BTU/hr)	Fuel		Temperature (°F)
			Type	BTU/hr	
Primary Chamber					
Secondary Chamber					

Stack Height: \_\_\_\_\_ ft. Stack Diameter: \_\_\_\_\_ Stack Temp. \_\_\_\_\_  
 Gas Flow Rate: \_\_\_\_\_ ACFM \_\_\_\_\_ DSCFM\* Velocity: \_\_\_\_\_ FPS

\*If 50 or more tons per day design capacity, submit the emissions rate in grains per standard cubic foot dry gas corrected to 50% excess air.

Type of pollution control device:  Cyclone  Wet Scrubber  Afterburner  
 Other (specify) \_\_\_\_\_

Brief description of operating characteristics of control devices: \_\_\_\_\_

\_\_\_\_\_  
\_\_\_\_\_  
\_\_\_\_\_

Ultimate disposal of any effluent other than that emitted from the stack (scrubber water, ash, etc.):

\_\_\_\_\_  
\_\_\_\_\_  
\_\_\_\_\_

NOTE: Items 2, 3, 4, 6, 7, 8, and 10 in Section V must be included where applicable.

#### SECTION V: SUPPLEMENTAL REQUIREMENTS

Please provide the following supplements where required for this application.

1. Total process input rate and product weight -- show derivation [Rule 17-2.100(127)]
2. To a construction application, attach basis of emission estimate (e.g., design calculations, design drawings, pertinent manufacturer's test data, etc.) and attach proposed methods (e.g., FR Part 60 Methods 1, 2, 3, 4, 5) to show proof of compliance with applicable standards. To an operation application, attach test results or methods used to show proof of compliance. Information provided when applying for an operation permit from a construction permit shall be indicative of the time at which the test was made.
3. Attach basis of potential discharge (e.g., emission factor, that is, AP42 test).
4. With construction permit application, include design details for all air pollution control systems (e.g., for baghouse include cloth to air ratio; for scrubber include cross-section sketch, design pressure drop, etc.)
5. With construction permit application, attach derivation of control device(s) efficiency. Include test or design data. Items 2, 3 and 5 should be consistent: actual emissions = potential (1-efficiency).
6. An 8 1/2" x 11" flow diagram which will, without revealing trade secrets, identify the individual operations and/or processes. Indicate where raw materials enter, where solid and liquid waste exit, where gaseous emissions and/or airborne particles are evolved and where finished products are obtained.
7. An 8 1/2" x 11" plot plan showing the location of the establishment, and points of airborne emissions, in relation to the surrounding area, residences and other permanent structures and roadways (Example: Copy of relevant portion of USGS topographic map).
8. An 8 1/2" x 11" plot plan of facility showing the location of manufacturing processes and outlets for airborne emissions. Relate all flows to the flow diagram.

- 9. The appropriate application fee in accordance with Rule 17-4.05. The check should be made payable to the Department of Environmental Regulation.
- 10. With an application for operation permit, attach a Certificate of Completion of Construction indicating that the source was constructed as shown in the construction permit.

**SECTION VI: BEST AVAILABLE CONTROL TECHNOLOGY**

A. Are standards of performance for new stationary sources pursuant to 40 C.F.R. Part 60 applicable to the source?

Yes  No

Contaminant	Rate or Concentration

B. Has EPA declared the best available control technology for this class of sources (if yes, attach copy)

Yes  No

Contaminant	Rate or Concentration

C. What emission levels do you propose as best available control technology?

Contaminant	Rate or Concentration

D. Describe the existing control and treatment technology (if any).

- |                           |                          |
|---------------------------|--------------------------|
| 1. Control Device/System: | 2. Operating Principles: |
| 3. Efficiency:*           | 4. Capital Costs:        |

Explain method of determining

5. Useful Life:

6. Operating Costs:

7. Energy:

8. Maintenance Cost:

9. Emissions:

Contaminant

Rate or Concentration

Contaminant	Rate or Concentration

10. Stack Parameters

a. Height:

ft.

b. Diameter:

ft.

c. Flow Rate:

ACFM

d. Temperature:

°F.

e. Velocity:

FPS

E. Describe the control and treatment technology available (As many types as applicable, use additional pages if necessary).

1.

a. Control Device:

b. Operating Principles:

c. Efficiency:<sup>1</sup>

d. Capital Cost:

e. Useful Life:

f. Operating Cost:

g. Energy:<sup>2</sup>

h. Maintenance Cost:

i. Availability of construction materials and process chemicals:

j. Applicability to manufacturing processes:

k. Ability to construct with control device, install in available space, and operate within proposed levels:

2.

a. Control Device:

b. Operating Principles:

c. Efficiency:<sup>1</sup>

d. Capital Cost:

e. Useful Life:

f. Operating Cost:

g. Energy:<sup>2</sup>

h. Maintenance Cost:

i. Availability of construction materials and process chemicals:

<sup>1</sup>Explain method of determining efficiency.

<sup>2</sup>Energy to be reported in units of electrical power - KWH design rate.

- j. Applicability to manufacturing processes:
- k. Ability to construct with control device, install in available space, and operate within proposed levels:

3.

- a. Control Device:
- b. Operating Principles:
- c. Efficiency:<sup>1</sup>
- d. Capital Cost:
- e. Useful Life:
- f. Operating Cost:
- g. Energy:<sup>2</sup>
- h. Maintenance Cost:
- i. Availability of construction materials and process chemicals:
- j. Applicability to manufacturing processes:
- k. Ability to construct with control device, install in available space, and operate within proposed levels:

4.

- a. Control Devices:
- b. Operating Principles:
- c. Efficiency:<sup>1</sup>
- d. Capital Costs:
- e. Useful Life:
- f. Operating Cost:
- g. Energy:<sup>2</sup>
- h. Maintenance Cost:
- i. Availability of construction materials and process chemicals:
- j. Applicability to manufacturing processes:
- k. Ability to construct with control device, install in available space, and operate within proposed levels:

F. Describe the control technology selected:

- 1. Control Device:
- 2. Efficiency:<sup>1</sup>
- 3. Capital Cost:
- 4. Useful Life:
- 5. Operating Cost:
- 6. Energy:<sup>2</sup>
- 7. Maintenance Cost:
- 8. Manufacturer:
- 9. Other locations where employed on similar processes:
- a. (1) Company:
- (2) Mailing Address:
- (3) City:
- (4) State:

Explain method of determining efficiency.

Energy to be reported in units of electrical power - KWH design rate.



(5) Environmental Manager:

(6) Telephone No.:

(7) Emissions:<sup>1</sup>

Contaminant

Rate or Concentration

(8) Process Rate:<sup>1</sup>

b. (1) Company:

(2) Mailing Address:

(3) City:

(4) State:

(5) Environmental Manager:

(6) Telephone No.:

(7) Emissions:<sup>1</sup>

Contaminant

Rate or Concentration

(8) Process Rate:<sup>1</sup>

10. Reason for selection and description of systems:

<sup>1</sup>Applicant must provide this information when available. Should this information not be available, applicant must state the reason(s) why.

SECTION VII - PREVENTION OF SIGNIFICANT DETERIORATION

A. Company Monitored Data

1. \_\_\_\_\_ no. sites \_\_\_\_\_ TSP \_\_\_\_\_ ( ) SO<sub>2</sub> \_\_\_\_\_ Wind spd/dir \_\_\_\_\_

Period of Monitoring \_\_\_\_\_ / \_\_\_\_\_ / \_\_\_\_\_ to \_\_\_\_\_ / \_\_\_\_\_ / \_\_\_\_\_  
month day year month day year

Other data recorded \_\_\_\_\_

Attach all data or statistical summaries to this application.

Specify bubbler (B) or continuous (C).



*HARRIS SEMICONDUCTOR*  
*AIR PERMIT - BUILDING 63*  
*ATTACHMENT A*  
*PROCESS DESCRIPTION*

## Attachment A

The primary processes occurring in Building 63 are wafer fabrication and assembly. Because the processes and equipment utilized in the two areas are, for the most part, dissimilar, the two areas are described separately.

The VHSIC wafer fabrication area employs a series of manufacturing procedures referred to as layering, patterning, doping and heating. The frequency and sequence of these processes can vary depending on the desired nature of the final product.

In the controlled environment of the fabrication clean room, wafer surfaces first undergo acid and/or solvent cleaning, followed by thermal oxidation in furnaces to form a layer of silicon dioxide on the wafer surface.

During the patterning process, the wafers are initially baked and primed. Coaters then spin a thin layer of "photoresist" on the wafer, after which the wafers are soft baked. Next, the circuit pattern is projected onto the wafers via "aligners" or "steppers." Developers are then applied to remove unpolymerized areas of photoresist. This is followed by a solvent rinse.

Next, the wafers are hard-baked, inspected to determine accuracy, and etched by wet (acid bath) or dry (plasma vapor) mechanisms. Once etching is complete, the photoresist is stripped off the wafer using chemical baths or plasma techniques.

In another step of the fabrication process, "dopant" atoms are either diffused into the wafer in diffusion furnaces, or accelerated into the wafer using "ion implantation." Fumes from the vapor deposition furnaces are oxidized in 'burn boxes.' The oxidized gases are then exhausted to scrubber systems. Additional material may be layered on the wafer surface in vapor and crystal (epitaxial) deposition furnaces. Metallization to interconnect uppermost circuit layers is performed by deposition (using "sputtering" systems) or evaporation.

In addition to the fabrication clean room, the building houses a chemical mixing room. This room contains exhausted stations and chemical cabinets.

Exhausted gas cabinets, vacuum pumps and chemical drains are located in the chases between the processing areas of the fab.

In the two assembly areas, a series of processing and quality control steps are incorporated that produce integrated circuits from the wafers. Wafers are cut (or 'diced') into the individual units (or die) they are comprised of. The die are then put into the circuit packages and the wires are ultrasonically bonded. The resulting integrated circuits are tested for a wide variety of parameters including tolerance to temperature and humidity changes, endurance, and electrical conductivity. Exhausted equipment includes degreasers, die wash units, bake ovens, fine leak systems, furnaces, and stations dedicated to the cleaning of product parts.

Wet stations that house vats containing a variety of acid and caustic compounds are located in the two areas. Approximately 20 stations are utilized. Five of these stations are estimated to be heated, and five stations contain vats of chemicals that are covered. Approximately half of the 20 stations are dedicated to the use of solvents.

Three wet scrubbing systems handle equipment exhaust from building 63. Two of these systems, F63S01 and F63S02, are located on the east side of the building at ground level. F63S01 provides exhaust and pollution control for acid exhaust drawn from the equipment in the wafer fab and chemical mix room, while F63S02 provides solvent exhaust for the fab, the chemical mix room, and one of the assembly areas. The third scrubber system, F63S03, is located on the roof. This scrubber provides solvent exhaust for equipment in the other assembly area (see attached location maps.)

Each of the two assembly areas house a fine leak system that utilize Krypton 85 gas to pressurize electronic components and to detect faulty hermetic seals in circuits. Each system has its own exhaust fan; the systems and the corresponding roof fans are permitted under a radioactive materials license by the State of Florida Department of Health and Rehabilitative Services Office of Radiation Control (license number 662-3.)

In addition, the BTU furnaces used for the burn-in of parts in Major Programs assembly are directly exhausted to the roof via vent pipes.

*HARRIS SEMICONDUCTOR*  
*AIR PERMIT - BUILDING 63*  
*ATTACHMENT B*  
*AIR EMISSIONS*

## SOLVENT MONITORING--BUILDING 63

Monitoring work was performed on the building 63 solvent scrubber systems F63S02 and F63S03 during December of 1986. Tests conducted include EPA methods 25A (flame ionization detection.) The results of the testing is included in this application.

FID test results revealed that total accumulative monitored VOC emissions for the building were 6.14 tons/year expressed as propane. This figure is based on a hypothetical production schedule of 8760 hours a year. The following assumptions were made regarding monitoring work on this building:

-VOC values refer to all organic emissions including organic solvents.

-All data was corrected for 2 ppm background noise that is normally present in the ambient air.

-The F.I.D. accumulative emission figure is based on the maximum concentration of VOC's observed during the monitoring time frame.

EPA METHOD 25-A (F.I.D. ANALYSIS) BUILDING 63  
VOC EMISSIONS DURING FULL PRODUCTION

TEST DATE	SCRUBBER #	PRODUCTN SCHEDULE (HRS/YR)	VOC EMISSIONS (TON/YR)
12/10/88	F63S02	8760	2.02
12/11/88	F63S03	8760	4.12

TOTAL PROJECTED VOC EMISSIONS FOR BLDG 63 = 6.14 TONS/YEAR



## ACID MONITORING--BUILDING 63

Monitoring was performed on the building 63 acid scrubber F63S01 in August of 1988. Samples were collected using modified EPA method 8 sampling train. The impinger medium consisted of a 0.1 N sodium hydroxide solution. The analytical methodology utilized to determine the ions of highest concentration is as follows:

Chloride ion--EPA Method 325.3

Fluoride ion--EPA Method 340.2

Nitrate, phosphite, and sulfate ions--ion chromatography

All results were in pounds per hour as "X", where "X" represents the acid compound present in highest concentration.

The test results revealed that the total accumulative monitored acid emissions for the building were 0.2146 tons/year expressed as hydrochloric, hydrofluoric, nitric, phosphoric and sulfuric acids. This figure is based on a hypothetical production schedule of 8760 hours a year. The monitoring was performed over an 8 hour time interval when the full production was occurring.

When a resulting acid concentration was expressed as a "less than 'y' " value, where 'y' represents the lowest detectable limit possible using the analytical methodology employed, acid emissions were taken to be equal to this 'y' limit value.

RESULTS OF ACID MONITORING--BUILDING 63  
 PERFORMED IN AUGUST OF 1988  
 BASED ON FULL PRODUCTION

Scrubber #	HCl	HF	Nitric Acid	Phos- phoric Acid	Sulfuric Acid	TOTAL (TON/YR)
F63S01 outlet (lb/hr)	0.0100	0.0090	0.0090	0.0120	0.0090	
(ton/yr)	0.0438	0.0394	0.0394	0.0526	0.0394	0.2146

TOTAL ACID EMISSIONS INTO SCRUBBER OUTLET = 0.2146 TONS/YEAR

*HARRIS SEMICONDUCTOR*

*AIR PERMIT - BUILDING 63*

*ATTACHMENT C*

*RAW MATERIALS AND CHEMICALS*

BUILDING 63 CONSOLIDATED AIR PERMIT  
PROCESS SOLVENTS

1,1,1-TRIMETHYL-N-TRIMETHYL ETHER  
2-ETHOXYETHANOL  
2-METHOXYETHANOL  
2-METHOXYETHYL ACETATE  
ACETONE  
AMMONIUM FLUORIDE  
AMMONIUM HYDROXIDE  
CELLOSOLVE ACETATE  
CHLORINATED HYDROCARBONS  
CHLOROPENTAFLUOROETHANE  
CHLOROTRIFLUOROMETHANE  
DIBUTYLPHTHALATE  
DICHLORODIFLUOROMETHANE  
ETHANOL  
ETHYL CYANOACRYLATE  
FLUOROCARBON 77  
GLYCOL ESTER  
HEXAMETHYLDISILAZANE  
HYDROQUINONE  
ISOPROPANOL  
METHANOL  
METHYL ETHYL KETONE  
METHYL METHACRYLATE  
METHYL PHENYL ETHER  
METHYLENE CHLORIDE  
METHYL ISOPROPYL KETONE  
MONOETHANOLAMINE  
N-ALKYL DIMETHYL BENZYL  
N-BUTYL ACETATE  
PROPYLENE GLYCOL MONOMETHYL ETHER ACETATE  
POTASSIUM HYDROXIDE  
TERT-BUTYL ALCOHOL  
TETRAETHYL ORTHOSILICATE  
TETRAMETHYL BORATE  
TETRAMETHYL PHOSPHITE  
TETRAMETHYL AMMONIUM HYDROXIDE  
TOLUENE  
TRICHLOROETHANE  
TRICHLOROTRIFLUOROETHANE  
XYLENE

BUILDING 63 CONSOLIDATED AIR PERMIT  
PROCESS GASES

AMMONIA  
ARGON  
ARSINE  
BORON TRICHLORIDE  
BORON TRIFLUORIDE  
CARBON DIOXIDE  
CARBON TETRAFLUORIDE  
CHLORINE  
DIBORANE  
DICHLOROSILANE  
GERMAINE  
GERMANIUM HEXAFLUORIDE  
GERMANIUM TETRAFLUORIDE  
GERMANIUM TRIBROMIDE  
HALOCARBON 23  
HELIUM  
HYDROGEN  
HYDROGEN CHLORIDE  
NITROGEN  
NITROGEN TRIFLUORIDE  
NITROUS OXIDE  
OXYGEN  
OZONE  
PHOSPHINE  
PHOSPHOROUS PENTAFLUORIDE  
PROPANE  
SILANE  
SULFUR HEXAFLUORIDE  
TUNGSTEN HEXAFLUORIDE

BUILDING 63 CONSOLIDATED AIR PERMIT  
PROCESS CHEMICALS

ALKYL ARYL SULFONIC ACID  
AMMONIUM HYDROXIDE  
BARIUM HYDROXIDE  
CERIC SULFATE  
CHLOROMETHYLATE ALPHAMETHYLPOLYSTYRENE  
CHLOROSULFONIC ACID  
CRESOL  
ETHYL BENZYL AMMONIUM CHLORIDE  
FERRIC CYANIDE  
GLACIAL ACETIC ACID  
GUM RESIN  
HF  
HYDROCHLORIC ACID  
HYDROGEN PEROXIDE  
LEAD OXIDE  
NITRIC ACID  
PHOSPHORIC ACID  
POLYDIMETHYLSILOXANE  
POTASSIUM CYANIDE  
POTASSIUM FERRICYANIDE  
POTASSIUM HYDROXIDE  
POTASSIUM PHOSPHATE MONOBASIC  
SILANAMINE  
SULFURIC ACID  
TRIBUTOXYETHYLPHOSPHATE

*HARRIS SEMICONDUCTOR*  
*AIR PERMIT - BUILDING 63*  
*ATTACHMENT D*  
*CONTROL EQUIPMENT*

HARRIS SEMICONDUCTOR -- AIR PERMIT INFORMATION

CURRENT PERMIT

BUILDING: 63 DATE ISSUED : 09/16/86  
PERMIT NUMBER: AO 05-121930 RENEWAL DATE: 07/16/91  
PERMIT TYPE : OPERATING DATE EXPIRES: 09/14/91

AREA SERVED:  
PROCESS DESCRIPTION: ACID VAPOR SCRUBBER

PERMIT LIMITS

VOL. RATE (SCFM): 50,000  
ACID MIST (LB/HR): 0.0007  
SOLVENTS (LB/HR): --  
VOCS (LB/HR): --  
OPER. (HRS/YEAR): 6336

SPECIFIC CONDITIONS

ANNUAL OPERATING REPORT : 03/01  
NOTIFICATION OF VE TEST : 10/26  
ANNUAL VIS EMISSION TEST: 11/10

EQUIPMENT INFORMATION

MANUFACTURER : BEVERLY PACIFIC MODEL NUMBER : PS-50HT  
LOCATION : B63 GROUND EAST SIDE  
HARRIS ID NUMBER : F63S01 STACK HEIGHT (FT): 31  
VOLUME FLOW RATE (CFM): 50,000 STACK DIAMETER (IN): 54  
RECIRCULATION RATE (GPM): 225 STACK VELOCITY (FPM):  
MAKEUP WATER RATE (GPM): 22.0 DUCT MATERIAL : polypro

PERMIT HISTORY

PERMIT NUMBER: AC 05-54996  
DATE EXPIRED : 06/01/84

PERMIT NUMBER: AC 05-104511  
DATE EXPIRED : 06/30/86

PERMIT NUMBER:  
DATE EXPIRED :



**BEST AVAILABLE COPY**

HARRIS ID # : F63S01  
MANUFACTURER : BEVERLY PACIFIC MODEL NUMBER : CB-60  
SERIAL NUMBER: F-600 MATERIAL : FIBERGLASS  
DESCRIPTION : HORIZONTAL CROSS FLOW, NON-CLOGGING PVC SPRAY NOZZLES,  
2" POLYPROPYLENE PACKING, PVC MIST ELIMINATOR  
DWG. F-600-6

DESIGN DATA

VOLUME FLOW RATE (CFM): 50,000 PRESSURE DROP (IN):  
RECIRCULATION RATE (GPM): 225 MAKE UP RATE (GPM): 22

ACTUAL DATA

VOLUME FLOW RATE (CFM): PRESSURE DROP (IN): N/E DATE: 87-06-03  
RECIRCULATION RATE (GPM): 90 MAKE UP RATE (GPM): 7.5 DATE: "

RECIRCULATION PUMP INFORMATION

-----  
MANUFACTURER : FILTER PUMP IND MODEL NUMBER : 36E 188-105  
SERIAL NUMBER: F 1280 HP : 3 RPM : 3450  
BRKR LOCATION: NEXT TO UNIT FED FROM MCC : 634

FAN INFORMATION

-----  
HARRIS ID # :  
MANUFACTURER : BEVERLY PACIFIC MODEL NUMBER: CB-60  
SERIAL NUMBER: F-600 MATERIAL : FIBERGLASS  
DESCRIPTION : CENTRIFUGAL TYPE, CLASS II, BACKWARD CURVED BLADES,  
DWG. F-600-6

DESIGN DATA

VOLUME FLOW RATE (CFM): 50,000 STATIC PRESS (IN): 5.0

ACTUAL DATA

VOLUME FLOW RATE (CFM): SPEED (RPM): 632 DATE: SUBMITTAL  
STATIC PRESS (IN): DATE:

FAN MOTOR INFORMATION

-----  
MANUFACTURER : MODEL NUMBER :  
SERIAL NUMBER: HP : 75 RPM :  
BRKR LOCATION: NEXT TO UNIT FED FROM MCC : 634

ttachment :

HARRIS SEMICONDUCTOR -- AIR PERMIT INFORMATION

CURRENT PERMIT

BUILDING: 63 DATE ISSUED : 01/14/86  
PERMIT NUMBER: AC 05-104512 RENEWAL DATE: 04/01/86  
PERMIT TYPE : CONSTRUCTION DATE EXPIRES: 06/30/86

AREA SERVED:  
PROCESS DESCRIPTION: VOC/SOLVENT SCRUBBER

PERMIT LIMITS

VOL. RATE (SCFM): 10,000  
ACID MIST (LB/HR): --  
SOLVENTS (LB/HR): 0.0042  
VOCS (LB/HR): --  
OPER. (HRS/YEAR): 6336

SPECIFIC CONDITIONS

ANNUAL OPERATING REPORT :  
NOTIFICATION OF VE TEST :  
ANNUAL VIS EMISSION TEST:

EQUIPMENT INFORMATION

MANUFACTURER : BEVERLY PACIFIC MODEL NUMBER : PS-12VT  
LOCATION : B63 GROUND EAST SIDE  
HARRIS ID NUMBER : F63S02 STACK HEIGHT (FT): 35  
VOLUME FLOW RATE (CFM): 10.000 STACK DIAMETER (IN): 30  
RECIRCULATION RATE (GPM): 45 STACK VELOCITY (FPM):  
MAKEUP WATER RATE (GPM): 4.0 DUCT MATERIAL :

PERMIT HISTORY

PERMIT NUMBER: AC 05-54995  
DATE EXPIRED : 06/01/84

PERMIT NUMBER: AC 05-104512  
DATE EXPIRED : 06/30/86

PERMIT NUMBER:  
DATE EXPIRED :

BEST AVAILABLE COPY

HARRIS ID # : F63S02  
MANUFACTURER : BEVERLY PACIFIC MODEL NUMBER : PS-12VT  
SERIAL NUMBER: F-600 MATERIAL : FIBERGLASS  
DESCRIPTION : VERTICAL COUNTER-CURRENT, NON-CLOGGING PVC SPRAY NOZZLES,  
POLYPROPYLENE PACKING, PVC MIST ELIMINATOR, DWG. F-600-7

DESIGN DATA

VOLUME FLOW RATE (CFM): 12,000 PRESSURE DROP (IN):  
RECIRCULATION RATE (GPM): 45 MAKE UP RATE (GPM): 4.0

ACTUAL DATA

VOLUME FLOW RATE (CFM): 6040 PRESSURE DROP (IN): 1.5 DATE: 12/10/86  
RECIRCULATION RATE (GPM): 18 MAKE UP RATE (GPM): 4 DATE: 06/03/87

RECIRCULATION PUMP INFORMATION

MANUFACTURER : FILTER PUMP IND MODEL NUMBER : 35G205-82  
SERIAL NUMBER: F 481 HP : 1.5 RPM : 3450  
BRKR LOCATION: NEXT TO UNIT FED FROM MCC : 634

FAN INFORMATION

HARRIS ID # :  
MANUFACTURER : BEVERLY PACIFIC MODEL NUMBER: CB-24  
SERIAL NUMBER: F-600 MATERIAL : FIBERGLASS  
DESCRIPTION : CENTRIFUGAL TYPE, CLASS II, BACKWARD CURVED BLADES,  
DWG. F-600-7

DESIGN DATA

VOLUME FLOW RATE (CFM): 8,823 STATIC PRESS (IN): 6.0

ACTUAL DATA

VOLUME FLOW RATE (CFM): 6040 SPEED (RPM): 1651 DATE: SUBMITTAL  
STATIC PRESS (IN): DATE: 12/10/86

FAN MOTOR INFORMATION

MANUFACTURER : MODEL NUMBER :  
SERIAL NUMBER: HP : 15 RPM :  
BRKR LOCATION: FS 63-1 FED FROM MCC : 634

ttachment :

HARRIS SEMICONDUCTOR -- AIR PERMIT INFORMATION

CURRENT PERMIT

BUILDING: 63 DATE ISSUED : 02/28/86  
PERMIT NUMBER: AC 05-108260 RENEWAL DATE: 04/01/86  
PERMIT TYPE : CONSTRUCTION DATE EXPIRES: 06/30/86

AREA SERVED: WEST ASSEMBLY AREA  
PROCESS DESCRIPTION: FUME SCRUBBER

PERMIT LIMITS

VOL. RATE (SCFM): 6,000  
ACID MIST (LB/HR): --  
SOLVENTS (LB/HR): 0.005  
VOCS (LB/HR): --  
OPER. (HRS/YEAR): 2112

SPECIFIC CONDITIONS

ANNUAL OPERATING REPORT :  
NOTIFICATION OF VE TEST :  
ANNUAL VIS EMISSION TEST:

EQUIPMENT INFORMATION

MANUFACTURER : TR4-MER CORP. MODEL NUMBER : F/W 5  
LOCATION : B63 ROOF WEST SIDE  
HARRIS ID NUMBER : F63S03 STACK HEIGHT (FT): 11  
VOLUME FLOW RATE (CFM): 6,000 STACK DIAMETER (IN): 22  
RECIRCULATION RATE (GPM): 36 STACK VELOCITY (FPM):  
MAKEUP WATER RATE (GPM): 3.5 DUCT MATERIAL : galv.

PERMIT HISTORY

PERMIT NUMBER: AC 05-108260  
DATE EXPIRED : 06/30/86

PERMIT NUMBER:  
DATE EXPIRED :

PERMIT NUMBER:  
DATE EXPIRED :

**BEST AVAILABLE COPY**

HARRIS ID # : F63S03  
 MANUFACTURER : TRI-MER CORP. MODEL NUMBER : F/WR-5  
 SERIAL NUMBER : 9054 MATERIAL : POLYPRO  
 DESCRIPTION : HORIZONTAL COUNTER-FLOW, MIST ELIMINATOR,  
 BLACK POLYPRO FILTER PACK, DWG. 1000-1408 (8/85)

## DESIGN DATA

VOLUME FLOW RATE (CFM): 6000 PRESSURE DROP (IN):  
 RECIRCULATION RATE (GPM): 36 MAKE UP RATE (GPM): 3.5

## ACTUAL DATA

VOLUME FLOW RATE (CFM): 6840 PRESSURE DROP (IN): DATE: 12/11/86  
 RECIRCULATION RATE (GPM): 30 MAKE UP RATE (GPM): 3 DATE: 01/16/87

## RECIRCULATION PUMP INFORMATION

-----  
 MANUFACTURER : CENTURY MODEL NUMBER : 8-159317-01  
 SERIAL NUMBER: BB1 HP : 1 RPM : 3450  
 BRKR LOCATION: NEXT TO UNIT FED FROM MCC : 2-2

## FAN INFORMATION

-----  
 HARRIS ID # :  
 MANUFACTURER : TRI-MER CORP. MODEL NUMBER: 300  
 SERIAL NUMBER: 5857 MATERIAL : PVC  
 DESCRIPTION : CENTRIFUGAL BLOWER, BACKWARD INCLINED BLADES

## DESIGN DATA

VOLUME FLOW RATE (CFM): 6,000 STATIC PRESS (IN): 4.0

## ACTUAL DATA

VOLUME FLOW RATE (CFM): 6840 SPEED (RPM): DATE:  
 STATIC PRESS (IN): DATE: 12/11/86

## FAN MOTOR INFORMATION

-----  
 MANUFACTURER : LINCOLN TEFC MODEL NUMBER : FRAME 213T  
 SERIAL NUMBER: N/A HP : 7.5 RPM : 1745/3450  
 BRKR LOCATION: NEXT TO UNIT FED FROM MCC : 63-4-18

ttachment :

# The Tri-Mer Fume Washer

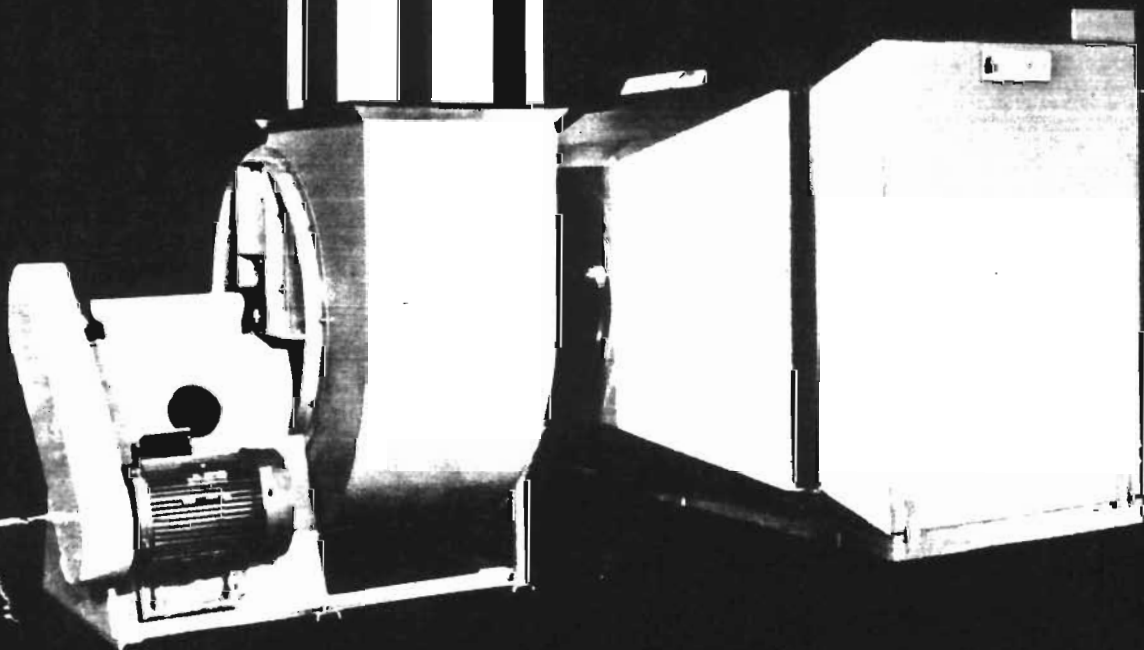

**Designers and Manufacturers of Corrosion Control Systems**

# WHY SPECIFY A TRI-MER BLOWER

Summarizing our unique combination of product benefits, **TRI-MER** blowers offer you . . .



- Exceptional Corrosion Resistance
- Compatibility With Pollution Control Systems
- Fire Retardancy
- Excellence in Design and Materials
- Easy Installation and Maintenance
- Quality Control and Fine Balance
- Wide Range of Sizes and Discharge Configurations
- Broad Selection of Accessories

## \* NOW LET'S LOOK AT PERFORMANCE HERE ARE SOME FACTS YOU NEED TO KNOW:

When ordering a blower, most buyers are concerned with three parameters; C.F.M., static pressure, and horsepower required. Occasionally outlet velocity may be important. C.F.M. concerns the volume of air you wish to move, static pressure corresponds to pressure drop, and horsepower required relates to efficiency.

Static pressure or resistance to air flow in a system is usually measured in inches of water. It equals the sum of all the pressure losses due to friction through the ductwork including straight sections, restrictions, and turns. Static pressure is sometimes calculated, sometimes estimated, and sometimes measured on an equivalent system. Whatever your method of determining your requirement, our **backwardly-inclined non-overloading** wheel design will protect your operation if system changes occur. In the event of static pressure change, only the C.F.M. and velocity will be altered; horsepower requirement remains essentially the same for the fan speed selected originally.

The table below illustrates this power limiting principle used in our Type I unplasticized PVC fans. Note that color band on chart corresponds to best selection bands (shaded areas) on capacity tables.

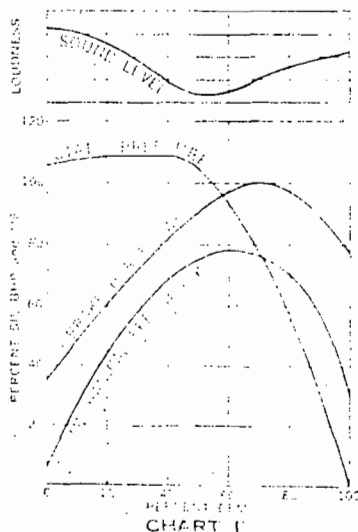

TYPICAL FAN PERFORMANCE

## Design and Performance

**Moderate Efficiency in Working Range** — maximum efficiency level covers best selection area of static pressure curve, well to the right of peak allowing ample pressure reserve at most efficient rating points.

**Lowest Sound Level in Working Range** — Lowest sound level falls in best pressure selection range.

**Non-overloading Horsepower Characteristic** — brake horsepower levels off at a point that allows economical selection of motors that will not overload if system changes occur.

# Design Features of the Tri-Mer Fume Washer

TRI-MER fume washers offer an efficient economically packaged solution to your corrosive fume problems. Couple this unit to a TRI-MER all PVC fan, or use your existing fan, and you're ready for operation. A simple inexpensive installation.

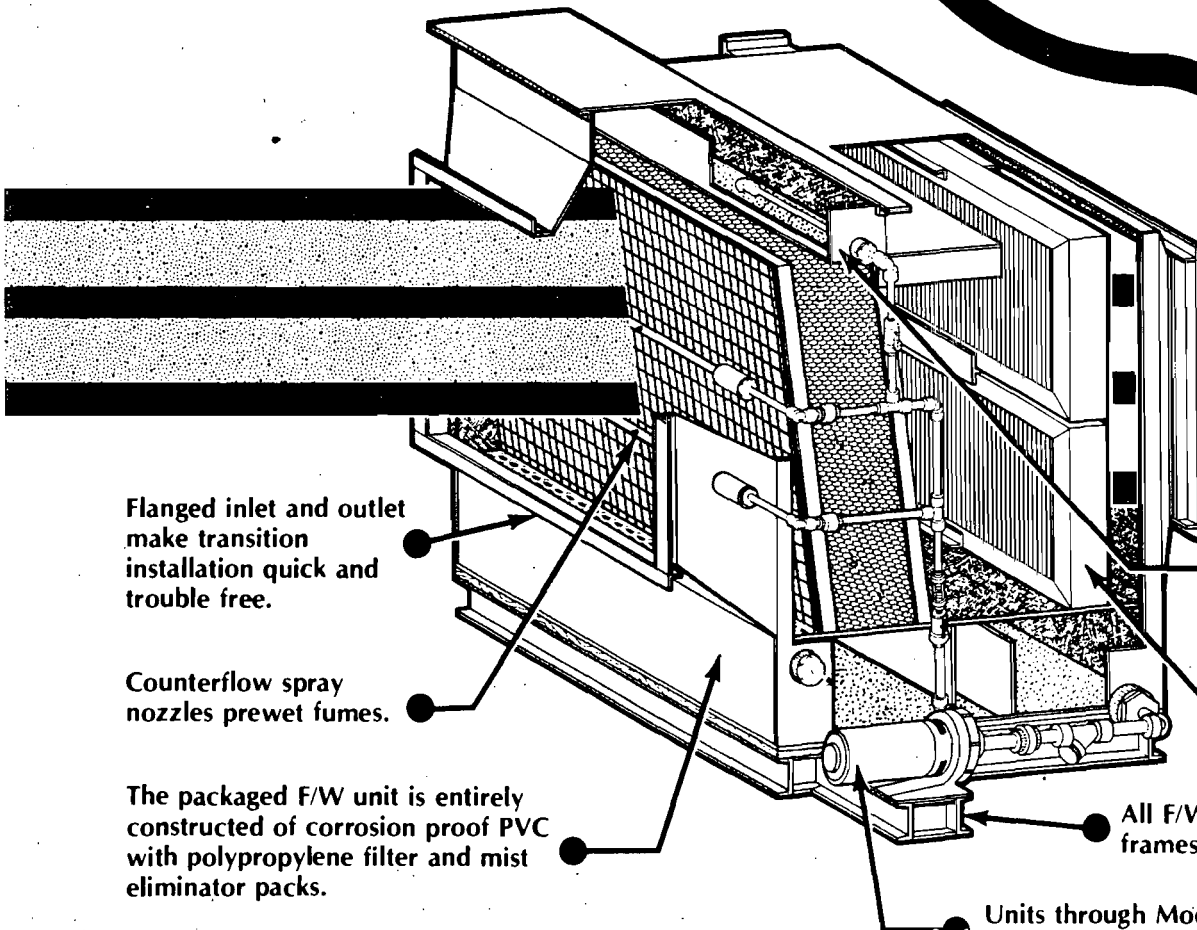
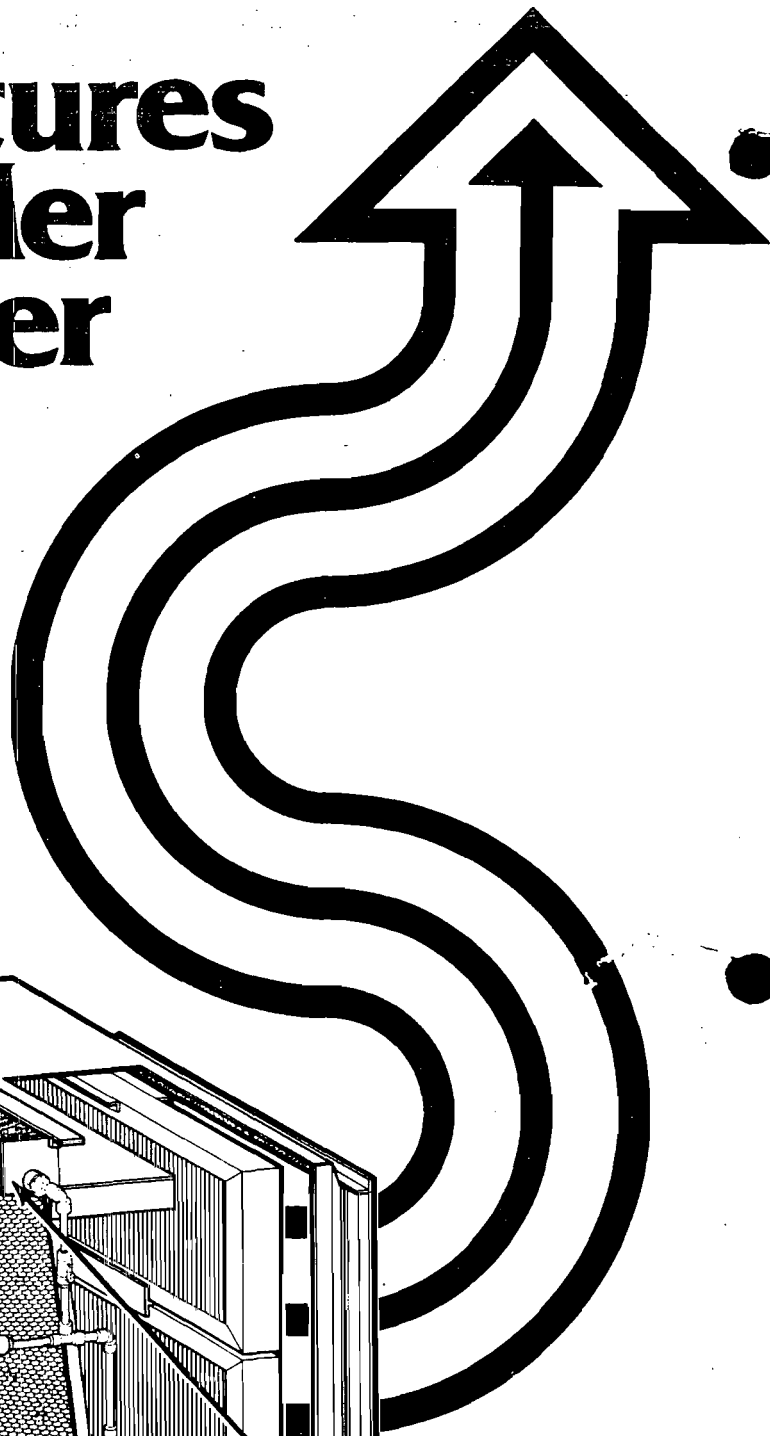

Flanged inlet and outlet make transition installation quick and trouble free.

Counterflow spray nozzles prewet fumes.

The packaged F/W unit is entirely constructed of corrosion proof PVC with polypropylene filter and mist eliminator packs.

An overflow weir keeps the polypropylene filter pack flooded with water.

Downstream mist eliminator packs pull excess moisture from the air stream.

All F/W units come with self supporting frames.

Units through Model F/W-9 are available with integral recirculation tank and pump as shown. NOTE — Models F/W-10 through F/W-16 require remote recirculation tanks per manufacturers suggestion.



F/W	A	B	C	D	E	F	G	H	J	K	L	M	R	CHANNEL	ANGLE	DRAIN	G.P.M.	No. OF HEADERS	PIPE	CFM CAPACITY			
1	3'-11 1/2"	4'-4 1/2"	3'-6"	4'-3"	5'-3"	3'-4"	3'-4"	4'-10"	6"	6"	28"	28"	1'-8"	2'-0 1/4"	3'-0 1/4"	8"	4"@5.4#	1 1/2"x1 1/2"x3/16"	3"	8	2	3/4"	3,000 to 5,500
2	4'-3 1/2"	4'-8 1/2"	3'-10"	4'-6 1/4"	5'-6 1/4"	3'-8"	3'-4"	5'-2"	4 1/2"	4 1/2"	35"	35"	1'-10"	2'-2 1/4"	3'-2 1/4"	8"	4"@5.4#	1 1/2"x1 1/2"x3/16"	3"	9	2	3/4"	5,500 to 7,000
3	5'-0 1/2"	5'-5 1/2"	3'-6"	5'-3 3/4"	6'-3 3/4"	4'-5"	4'-5"	4'-10"	8"	8"	37"	37"	2'-4 1/2"	2'-7 1/4"	3'-7 1/4"	8"	4"@5.4#	1 1/2"x1 1/2"x3/16"	3"	12	2	3/4"	7,000 to 9,500
4	5'-6"	5'-11"	4'-0"	5'-8 3/4"	6'-8 3/4"	4'-10"	4'-10"	5'-6"	6 1/2"	6 1/2"	45"	45"	2'-5"	2'-9 1/4"	3'-9 1/4"	9"	4"@5.4#	2"x2"x1/4"	3"	14	2	3/4"	9,500 to 11,500
5	6'-0"	6'-5"	3'-8 1/2"	6'-2 1/4"	7'-2 1/4"	5'-4"	5'-4"	5'-2 1/2"	9 1/2"	9 1/2"	45"	45"	2'-8"	3'-0 1/4"	4'-0 1/4"	9"	4"@5.4#	2"x2"x1/4"	3"	16	2	3/4"	11,500 to 14,000
6	6'-8"	7'-1"	4'-11 1/2"	6'-10 1/4"	7'-10 1/4"	6'-0"	6'-0"	6'-1 1/2"	11"	11"	50"	50"	3'-0"	3'-4 1/4"	4'-6 1/4"	1'-0"	4"@5.4#	2"x2"x1/4"	3"	19	2	3/4"	14,000 to 17,000
7	6'-11"	7'-5"	3'-10 1/4"	7'-3"	8'-3"	6'-4"	6'-4"	5'-10 1/4"	11"	11"	54"	54"	3'-2"	3'-6 1/4"	4'-6 1/4"	1'-0"	4"@5.4#	2"x2"x1/4"	3"	22	2	3/4"	17,000 to 20,000
8	7'-8"	8'-1"	4'-3"	7'-10 1/4"	8'-10 1/4"	7'-0"	7'-0"	6'-3"	1'-0 1/2"	1'-0 1/2"	59"	59"	3'-6"	3'-9 1/4"	3'-9 1/4"	1'-0"	4"@5.4#	2"x2"x1/4"	3"	28	2	3/4"	20,000 to 24,000
9	8'-5"	9'-0"	4'-0 1/4"	8'-8"	9'-8"	7'-9"	7'-9"	6'-0 1/4"	1'-1 1/2"	1'-1 1/2"	66"	66"	3'-10 1/2"	4'-2 1/4"	5'-2 1/4"	1'-0"	4"@5.4#	2"x2"x1/4"	3"	34	3	3/4"	24,000 to 30,000
10	9'-7"	4'-5"	9'-11 1/4"	8'-11"	8'-11"	6'-5"	1'-3 1/2"	1'-3 1/2"	76"	76"	4'-5 1/2"	5'-0 1/4"	1'-0"	6"@8.2#	2"x2"x1/4"	3"	44	3	1"	30,000 to 40,000			
11	12'-1"	4'-2 1/2"	9'-9 3/4"	8'-9"	11'-5"	6'-2 1/2"	10"	2'-2"	85"	85"	5'-8"	4'-11 1/4"	1'-0"	6"@8.2#	2"x2"x1/4"	3"	56	3	1"	40,000 to 50,000			
12	14'-5"	4'-5 1/2"	9'-9 3/4"	8'-9"	13'-9"	8'-5 1/2"	10"	2'-7 1/2"	85"	102"	6'-10 1/2"	4'-11 1/4"	2'-0"	6"@8.2#	2"x2"x1/4"	3"	66	3	1"	40,000 to 60,000			
14	17'-9"	4'-5 1/2"	9'-9 3/4"	8'-9"	17'-1"	8'-5 1/2"	10"	3'-2 1/2"	85"	128"	8'-5 1/2"	4'-11 1/4"	2'-0"	6"@8.2#	2"x2"x1/4"	3"	81	3	1"	40,000 to 75,000			
15	20'-8"	4'-2 1/2"	9'-9 3/4"	8'-9"	19'-10"	8'-2 1/2"	10"	3'-9 1/2"	85"	147"	9'-11"	4'-11 1/4"	2'-0"	6"@8.2#	2"x2"x1/4"	3"	93	3	1 1/2"	75,000 to 87,000			
16	20'-8"	4'-7"	11'-0 1/4"	10'-0"	20'-0"	8'-7"	1'-5 1/2"	3'-0"	85"	240"	10'-0"	5'-6 1/4"	2'-0"	6"@8.2#	2"x2"x1/4"	3"	106	3	1 1/2"	87,000 to 100,000			

\* NOTE — For exact unit weight check with manufacturers.

\* NOTE — Double pack models are available where particularly heavy loadings exist. Check with manufacturer for dimensional changes.

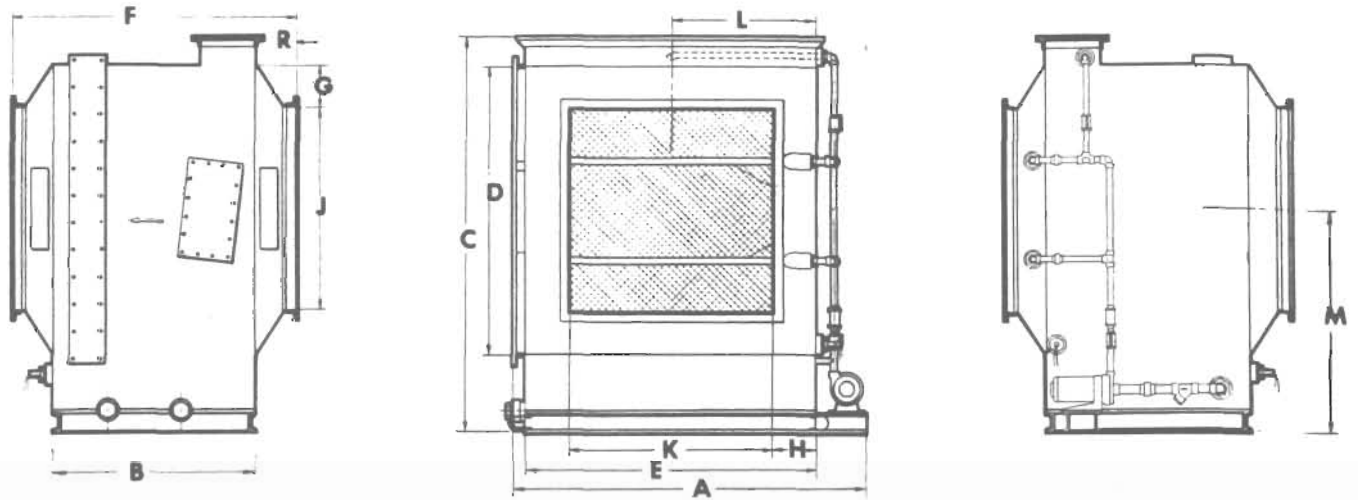

Typical three view drawing of units with integral recirculation tanks.

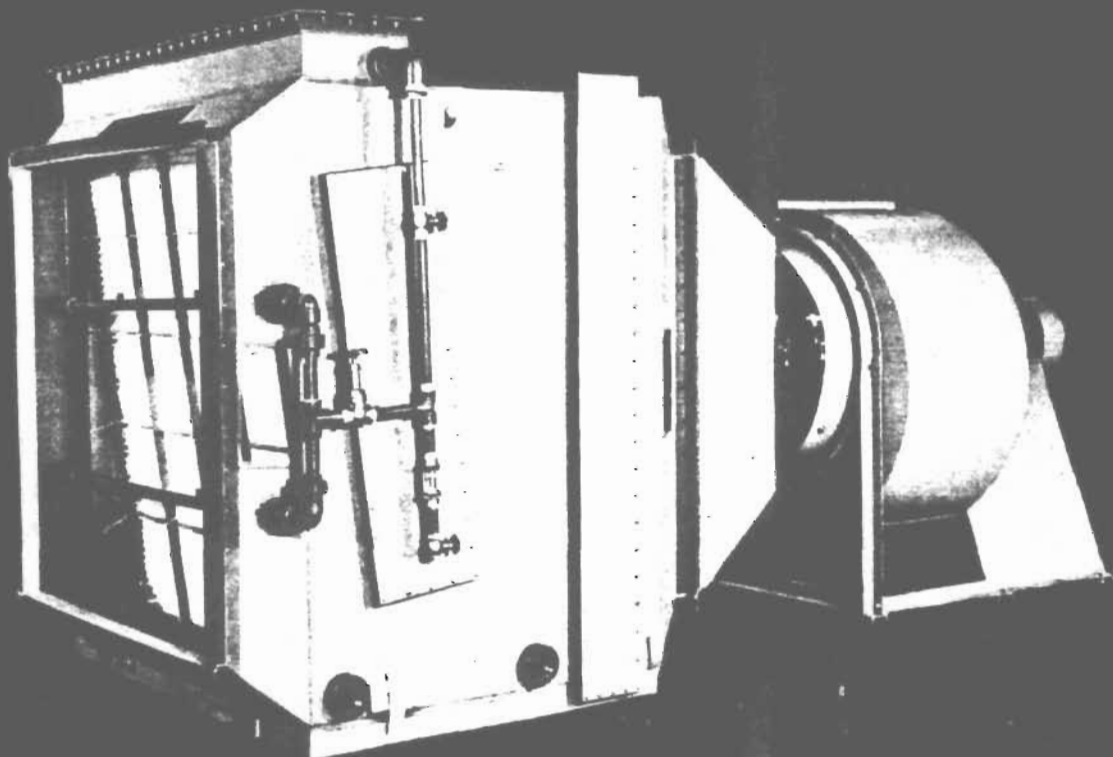

An assembled F/W-10 complete with Tri-Mer PVC Fan & Transition

# Other TRI-MER PVC Equipment

As long time specialists in designing corrosive fume control systems, TRI-MER offers a complete line of PVC air movers and associated equipment. This includes the patented fan/separator (fume scrubber), fume washers (crossflow scrubbers), PVC centrifugal fans, an *all PVC* stack fan, as well as PVC hoods and duct. Special fabrications such as consoles, tanks, and small plating lines are available.

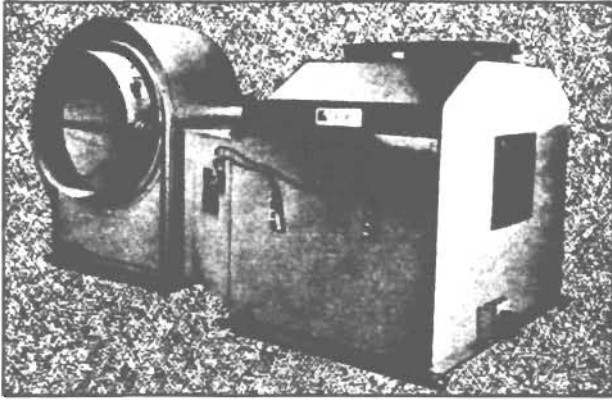

Fan/Separator

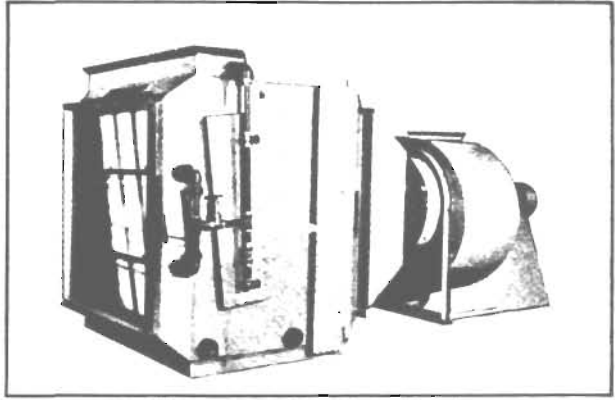

Fume/Washer (Crossflow Scrubber)



PVC Centrifugal Fan



PVC Stack Fan (Cutaway View)

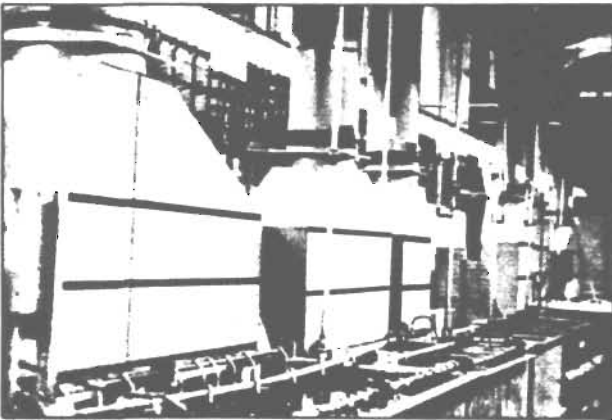

PVC Hoods & Duct

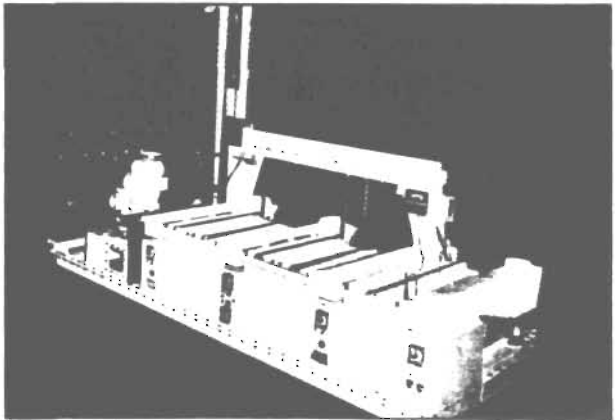

Special Fabrications



## Tri-Mer Corporation

Factory and Main Offices  
1400 Monroe, Owosso, Michigan 48867  
Phone (517) 723-7838 Telex 228545



## Tri-Mer Corporation

California Sales Offices  
P.O. Box 1152, Costa Mesa, California 92626  
Phone: (714) 548 5853

**K** EUROPEAN REPRESENTATIVE  
**JAEGER K. G.**  
D BRAUNSCHWEIG, WEST GERMANY

Litho in U.S.A.

BEST AVAILABLE COPY

# PVC

UNPLASTICIZED POLYVINYL CHLORIDE

## NON-OVERLOADING BLOWERS

(BACKWARD INCLINED BLADES)

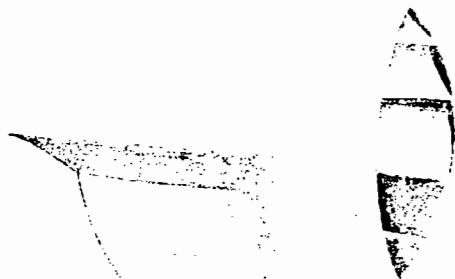

**Tri-Mer<sup>®</sup> Corporation**

**Air Pollution Control Systems**

*DESIGN • ENGINEERING • MANUFACTURING*

1400 Monroe Street • Owosso, Michigan 48867 • 517-723/5124 • Telex 228545

# STANDARD NOMENCLATURE

## Direction of Rotation and Discharge

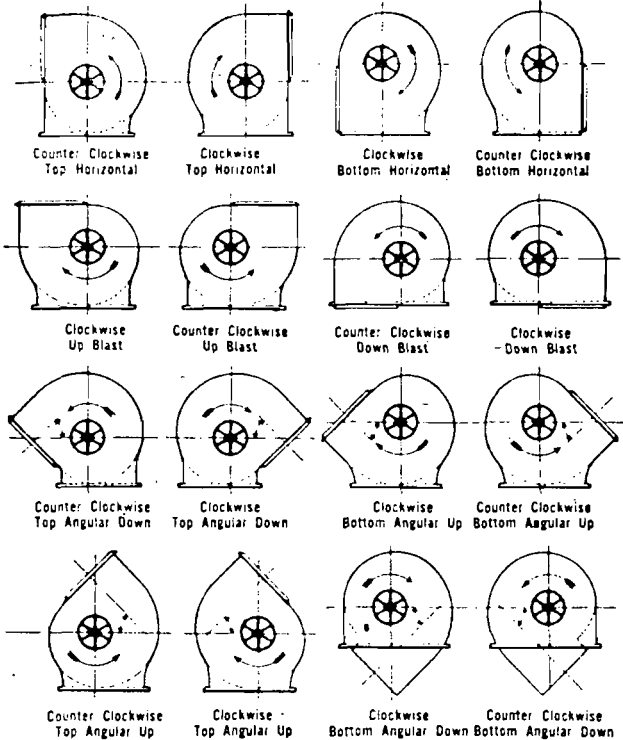

Direction of rotation is determined from the drive side. On single inlet fans, drive side is considered as opposite inlet, regardless of actual drive location.

## STANDARD MOTOR POSITIONS

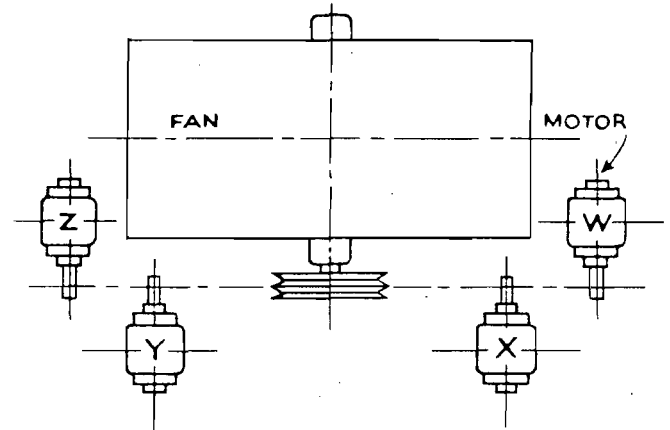

The location of motor is determined from plan view of the blower, designating the motor position by letters W, X, Y and Z as the case may be.

## ARRANGEMENTS OF DRIVE

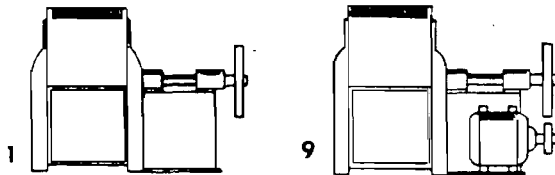

### ARRANGEMENT No. 1, SWSI

For belt drive or direct connection. Wheel overhung. Two bearings on base. Furnished in sizes 122 to 600 inclusive. Single inlet only.

### ARRANGEMENT No. 9, SWSI

For belt drive. Arrangement No. 1 designed for mounting prime mover on side of base. Furnished in sizes 122 to 600 inclusive. Single inlet only.

### SWSI — Class II

Heavier design than Class I. A one piece intermediate stiffening ring is also welded into each blade. Tip speed limit approximately 13000 FPM and 6 inches total pressure.

## CONSTRUCTION FEATURES

- HOUSING—All P.V.C.
- WHEEL—P.V.C. and Coated Steel
- INLET—1½" P.V.C. Angle Flange
- OUTLET—1½" P.V.C. Angle Flange
- DRAIN—2" P.V.C. Flanged
- CLEANOUT DOOR—P.V.C. Bolted
- STEEL FRAME—Epoxy Coated

Blowers are very rugged with heavy angle iron bracing, over capacity shaft and bearings. Formed P.V.C. venturi inlets give streamlined flow into the wheel with its own matching cone for very high efficiency and quiet operation. OPERATING TEMPERATURES UP TO 155°F.

CAPACITY TABLES



SIZE  
**30**

Wheel Diameter = 30"  
Wheel Circumference = 7.85'

Inlet Diameter = 33 1/4"  
Fan Outlet Area = 6.17 sq. ft.

Safe RPM = 1530  
Maximum BHP = 5.25 (RPM/1000)

CFM	OV	1/4" SP		3/8" SP		1/2" SP		5/8" SP		3" SP		4" SP		5" SP		6" SP	
		RPM	BHP	RPM	BHP	RPM	BHP	RPM	BHP	RPM	BHP	RPM	BHP	RPM	BHP	RPM	BHP
100	300	112	.17	137	.21	162	.24	187	.28	212	.32	237	.36	262	.40	287	.44
200	600	112	.34	137	.42	162	.48	187	.56	212	.64	237	.72	262	.80	287	.88
300	900	112	.51	137	.63	162	.72	187	.84	212	.96	237	1.08	262	1.20	287	1.32
400	1200	112	.68	137	.84	162	.96	187	1.12	212	1.28	237	1.44	262	1.60	287	1.76
500	1500	112	.85	137	1.05	162	1.20	187	1.44	212	1.76	237	2.00	262	2.24	287	2.48
600	1800	112	1.02	137	1.26	162	1.44	187	1.68	212	2.16	237	2.40	262	2.64	287	2.88
700	2100	112	1.19	137	1.47	162	1.68	187	1.92	212	2.40	237	2.72	262	2.88	287	3.12
800	2400	112	1.36	137	1.68	162	1.92	187	2.16	212	2.88	237	3.20	262	3.36	287	3.60
900	2700	112	1.53	137	1.89	162	2.16	187	2.40	212	3.12	237	3.52	262	3.60	287	3.84
1000	3000	112	1.70	137	2.10	162	2.40	187	2.64	212	3.36	237	3.84	262	3.92	287	4.08
1100	3300	112	1.87	137	2.31	162	2.64	187	2.88	212	3.60	237	4.00	262	4.08	287	4.32
1200	3600	112	2.04	137	2.52	162	2.88	187	3.12	212	3.84	237	4.32	262	4.32	287	4.56
1300	3900	112	2.21	137	2.73	162	3.12	187	3.36	212	4.00	237	4.48	262	4.40	287	4.80
1400	4200	112	2.38	137	2.94	162	3.36	187	3.60	212	4.16	237	4.64	262	4.48	287	5.04
1500	4500	112	2.55	137	3.15	162	3.60	187	3.84	212	4.32	237	4.80	262	4.56	287	5.28
1600	4800	112	2.72	137	3.36	162	3.84	187	4.08	212	4.48	237	4.96	262	4.64	287	5.52
1700	5100	112	2.89	137	3.57	162	4.08	187	4.32	212	4.64	237	5.12	262	4.72	287	5.76
1800	5400	112	3.06	137	3.78	162	4.32	187	4.56	212	4.80	237	5.28	262	4.80	287	6.00
1900	5700	112	3.23	137	3.99	162	4.56	187	4.80	212	4.96	237	5.44	262	4.88	287	6.24
2000	6000	112	3.40	137	4.20	162	4.80	187	5.04	212	5.12	237	5.60	262	4.96	287	6.48
2100	6300	112	3.57	137	4.41	162	5.04	187	5.28	212	5.28	237	5.76	262	5.04	287	6.72
2200	6600	112	3.74	137	4.62	162	5.28	187	5.52	212	5.44	237	5.92	262	5.12	287	6.96
2300	6900	112	3.91	137	4.83	162	5.52	187	5.76	212	5.60	237	6.08	262	5.20	287	7.20
2400	7200	112	4.08	137	5.04	162	5.76	187	6.00	212	5.76	237	6.24	262	5.28	287	7.44
2500	7500	112	4.25	137	5.25	162	6.00	187	6.24	212	5.92	237	6.40	262	5.36	287	7.68
2600	7800	112	4.42	137	5.46	162	6.24	187	6.48	212	6.08	237	6.56	262	5.44	287	7.92
2700	8100	112	4.59	137	5.67	162	6.48	187	6.72	212	6.24	237	6.72	262	5.52	287	8.16
2800	8400	112	4.76	137	5.88	162	6.72	187	6.96	212	6.40	237	6.88	262	5.60	287	8.40
2900	8700	112	4.93	137	6.09	162	6.96	187	7.20	212	6.56	237	7.04	262	5.68	287	8.64
3000	9000	112	5.10	137	6.30	162	7.20	187	7.44	212	6.72	237	7.20	262	5.76	287	8.88
3100	9300	112	5.27	137	6.51	162	7.44	187	7.68	212	6.88	237	7.36	262	5.84	287	9.12
3200	9600	112	5.44	137	6.72	162	7.68	187	7.92	212	7.04	237	7.52	262	5.92	287	9.36
3300	9900	112	5.61	137	6.93	162	7.92	187	8.16	212	7.20	237	7.68	262	6.00	287	9.60
3400	10200	112	5.78	137	7.14	162	8.16	187	8.40	212	7.36	237	7.84	262	6.08	287	9.84
3500	10500	112	5.95	137	7.35	162	8.40	187	8.64	212	7.52	237	8.00	262	6.16	287	10.08
3600	10800	112	6.12	137	7.56	162	8.64	187	8.88	212	7.68	237	8.16	262	6.24	287	10.32
3700	11100	112	6.29	137	7.77	162	8.88	187	9.12	212	7.84	237	8.32	262	6.32	287	10.56
3800	11400	112	6.46	137	7.98	162	9.12	187	9.36	212	8.00	237	8.48	262	6.40	287	10.80
3900	11700	112	6.63	137	8.19	162	9.36	187	9.60	212	8.16	237	8.64	262	6.48	287	11.04
4000	12000	112	6.80	137	8.40	162	9.60	187	9.84	212	8.32	237	8.80	262	6.56	287	11.28
4100	12300	112	6.97	137	8.61	162	9.84	187	10.08	212	8.48	237	8.96	262	6.64	287	11.52
4200	12600	112	7.14	137	8.82	162	10.08	187	10.32	212	8.64	237	9.12	262	6.72	287	11.76
4300	12900	112	7.31	137	9.03	162	10.32	187	10.56	212	8.80	237	9.28	262	6.80	287	12.00
4400	13200	112	7.48	137	9.24	162	10.56	187	10.80	212	8.96	237	9.44	262	6.88	287	12.24
4500	13500	112	7.65	137	9.45	162	10.80	187	11.04	212	9.12	237	9.60	262	6.96	287	12.48
4600	13800	112	7.82	137	9.66	162	11.04	187	11.28	212	9.28	237	9.76	262	7.04	287	12.72
4700	14100	112	7.99	137	9.87	162	11.28	187	11.52	212	9.44	237	9.92	262	7.12	287	12.96
4800	14400	112	8.16	137	10.08	162	11.52	187	11.76	212	9.60	237	10.08	262	7.20	287	13.20
4900	14700	112	8.33	137	10.29	162	11.76	187	12.00	212	9.76	237	10.24	262	7.28	287	13.44
5000	15000	112	8.50	137	10.50	162	12.00	187	12.24	212	9.92	237	10.40	262	7.36	287	13.68
5100	15300	112	8.67	137	10.71	162	12.24	187	12.48	212	10.08	237	10.56	262	7.44	287	13.92
5200	15600	112	8.84	137	10.92	162	12.48	187	12.72	212	10.24	237	10.72	262	7.52	287	14.16
5300	15900	112	9.01	137	11.13	162	12.72	187	12.96	212	10.40	237	10.88	262	7.60	287	14.40
5400	16200	112	9.18	137	11.34	162	12.96	187	13.20	212	10.56	237	11.04	262	7.68	287	14.64
5500	16500	112	9.35	137	11.55	162	13.20	187	13.44	212	10.72	237	11.20	262	7.76	287	14.88
5600	16800	112	9.52	137	11.76	162	13.44	187	13.68	212	10.88	237	11.36	262	7.84	287	15.12
5700	17100	112	9.69	137	11.97	162	13.68	187	13.92	212	11.04	237	11.52	262	7.92	287	15.36
5800	17400	112	9.86	137	12.18	162	13.92	187	14.16	212	11.20	237	11.68	262	8.00	287	15.60
5900	17700	112	10.03	137	12.39	162	14.16	187	14.40	212	11.36	237	11.84	262	8.08	287	15.84
6000	18000	112	10.20	137	12.60	162	14.40	187	14.64	212	11.52	237	12.00	262	8.16	287	16.08
6100	18300	112	10.37	137	12.81	162	14.64	187	14.88	212	11.68	237	12.16	262	8.24	287	16.32
6200	18600	112	10.54	137	13.02	162	14.88	187	15.12	212	11.84	237	12.32	262	8.32	287	16.56
6300	18900	112	10.71	137	13.23	162	15.12	187	15.36	212	12.00	237	12.48	262	8.40	287	16.80
6400	19200	112	10.88	137	13.44	162	15.36	187	15.60	212	12.16	237	12.64	262	8.48	287	17.04
6500	19500	112	11.05	137	13.65	162	15.60	187	15.84	212	12.32	237	12.80	262	8.56	287	17.28

# SWSI ARRANGEMENT 1

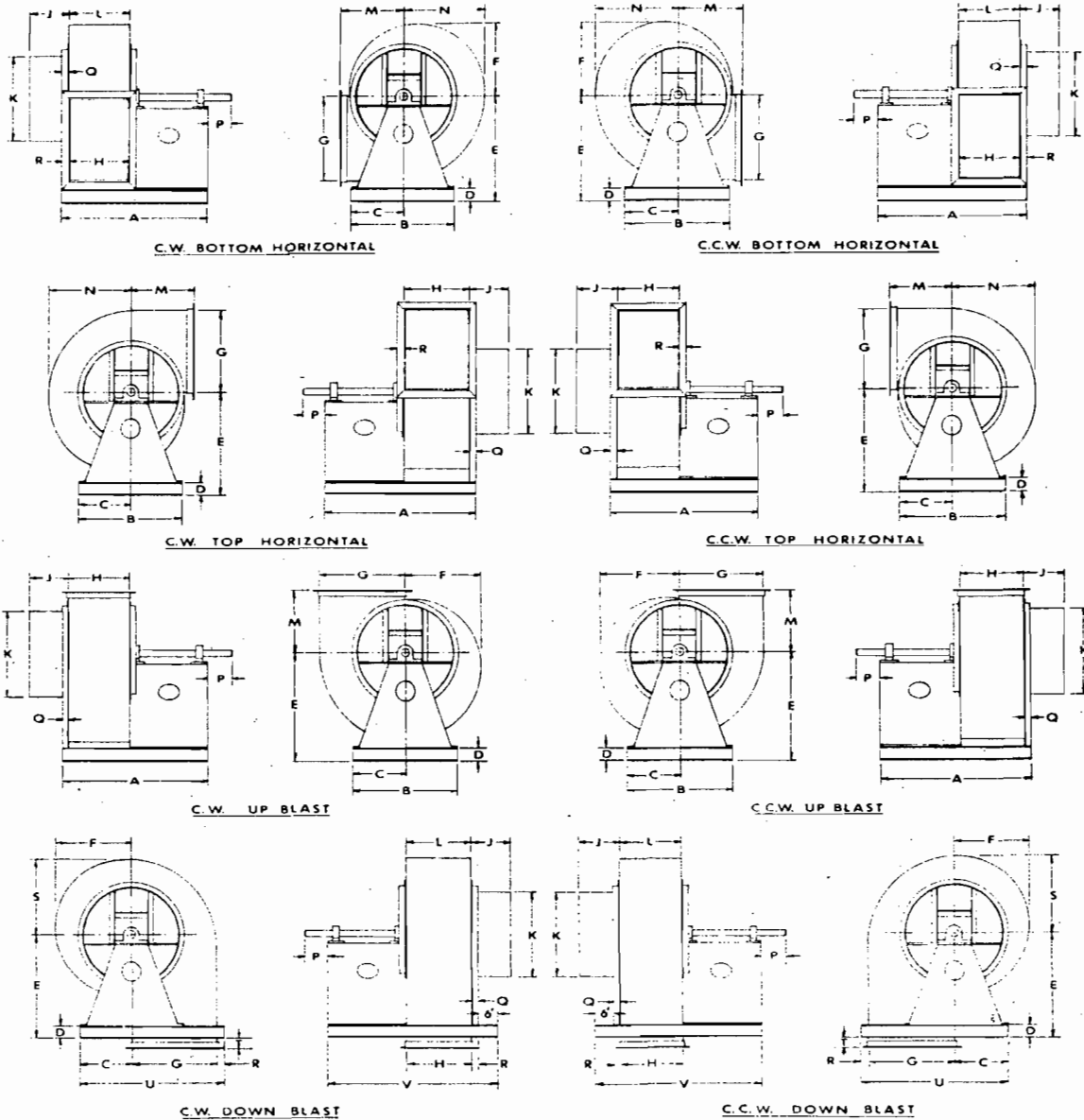

## DIMENSIONS — CLASS II

CERTIFIED PRINTS FURNISHED UPON REQUEST

MODEL NO	WHEEL DIA	SHAFT DIA	KEYWAY	A	B	C	D	E	F	G	H	J	K	L	M	N	P	Q	R	S	T	U	V
105	10 1/2	1	1/4 X 3/8 X 3 1/2	21 3/8	12	6	4	15 1/2	8 1/4	11 1/2	8 3/8	12	11	8 3/8	9	10 1/4	4	—	1 1/2	10 1/4	3	19	27 3/8
122	12 1/4	1	1/4 X 3/8 X 3 1/2	28 3/8	16	8	4	19 1/8	10	13	9 3/8	12	13	9 3/8	10 1/2	11 3/8	4	1 1/4	1 1/2	11 3/8	3	22 1/2	34 3/8
150	15	1 1/16	3/8 X 3/16 X 3 1/2	31 1/2	20	10	4	22 1/2	12 1/4	16	11 3/4	12	16	11 3/4	12 3/8	14	4	1 1/4	1 1/2	14	3	27 1/2	37 1/2
182	18 1/4	1 1/16	3/8 X 3/16 X 3 1/2	34 1/4	25	12 1/2	4	26	15	19 1/2	14 1/4	12	19	14 1/4	14 3/8	17	4	1 1/2	1 1/2	17	3	33 1/2	40 1/4
222	22 1/4	1 1/16	3/8 X 3/16 X 3 1/2	41 1/4	30	15	4	30 1/4	18 3/4	23 3/4	17 1/4	12	24	17 1/4	17 1/4	20 3/4	4	1 1/2	2	20 3/4	4	40 3/4	47 1/4
245	24 1/2	1 1/16	3/8 X 3/16 X 3 1/2	45 3/8	32	16	4	32 3/8	20 3/8	26 3/8	19 3/8	12	26	19 3/8	19 1/4	22 3/4	4	2	2	22 3/4	4	44 1/8	51 1/8
270	27	1 1/16	1/2 X 1/4 X 3 1/2	48 3/4	34	17	4	34 3/4	22	28 3/4	21 1/4	12	28	21 1/4	21 1/2	25 1/4	4 1/4	2	2	25 1/4	4	47 1/4	54 3/4
300	30	1 1/16	1/2 X 1/4 X 4	50 3/8	40	20	4	38 1/2	24 3/8	32	23 3/8	12	32	23 3/8	23 3/8	28	5 1/4	2	2	28	4	54	56 3/8
330	33	2 3/16	1/2 X 1/4 X 4	54 3/8	44	22	4	41 1/2	27	35	25 3/8	12	35	25 3/8	25 3/8	30 3/4	4 1/2	2	2	30 3/4	4	59	60 3/4
365	36 1/2	2 1/16	3/8 X 3/16 X 4 1/2	57 1/2	50	25	4	45 1/2	29 3/8	39	28 1/2	12	39	28 1/2	28	34	4 1/2	2	2	34	4	66	63 1/2
402	40 1/4	2 1/16	3/8 X 3/16 X 4 1/2	62 1/8	54	27	4	49 1/2	32 3/8	43	31 3/8	12	44	31 3/8	30 3/8	37 1/2	5 1/2	2	2	37 1/2	4	72	68 1/4
445	44 1/2	2 1/16	3/8 X 3/16 X 5	67 1/2	59	29 1/2	4	54	36 1/4	47 3/8	35	12	48	35	34	41 1/4	5 1/2	2 1/2	2	41 1/4	4	78 1/8	73 1/2
490	49	2 1/16	3/8 X 3/16 X 5	72 1/2	69	34 1/2	4	58 3/4	40 3/8	52 1/4	38 1/2	12	53	38 1/2	37 3/8	45 3/4	5 1/2	2 1/2	2	45 3/4	4	88 3/4	76 1/2
540	54	3 3/16	3/4 X 3/8 X 5	77 3/4	69	34 1/2	6	66 3/8	44 1/2	58 3/8	43 3/4	12	60	43 3/4	43 1/2	50	5 1/2	2 1/2	2	50	4	94 3/8	83 1/4
600	60	3 7/16	3/4 X 3/8 X 5	80 1/4	75	37 1/2	6	73 3/4	46 3/4	64 3/4	45 3/4	12	64	45 3/4	46	53 1/2	6 1/2	2 1/2	2	53 1/2	4	104 1/4	86 1/4

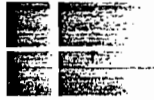
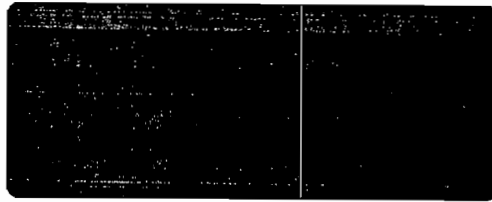

**BEVERLY PACIFIC CORPORATION**

Industrial Systems Division

SCRUBBERS

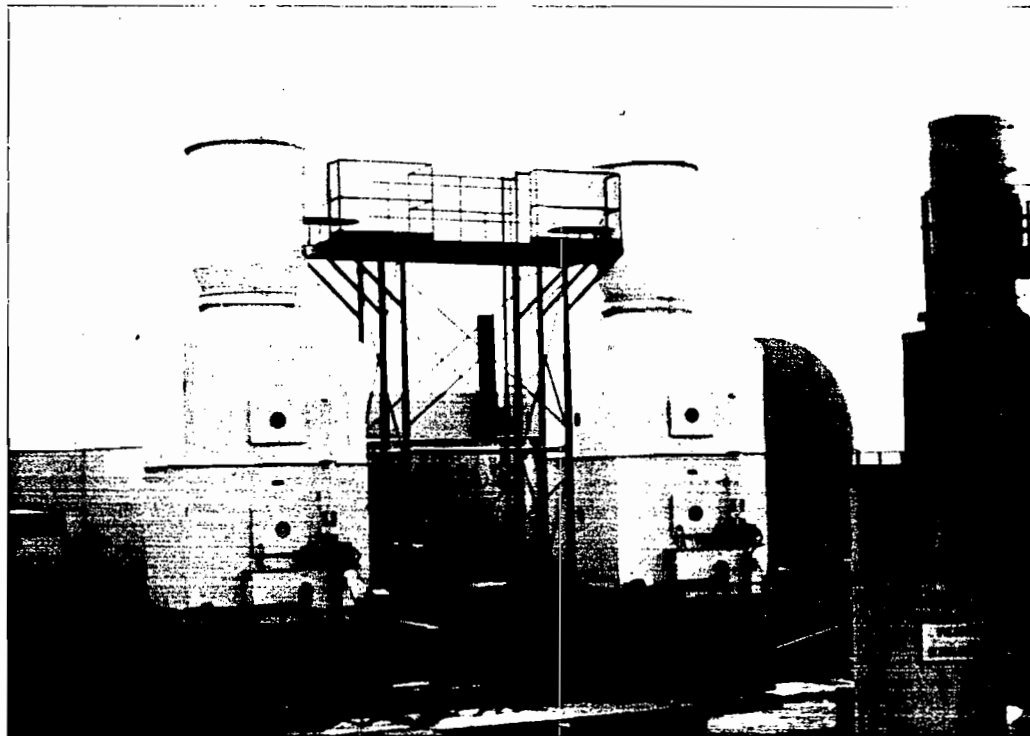

FIBERGLASS REINFORCED PLASTIC

## PACKED SCRUBBER DIMENSIONAL CHART MODEL NUMBERS DIMENSIONS IN INCHES

	PS-2	PS-4	PS-6	PS-8	PS-12	PS-18	PS-24	PS-30	PS-40	PS-50
<b>A</b>	78	82	84	94	101	108	112	114	118	118
<b>B</b>	24	36	42	48	60	72	84	96	108	120
<b>C</b>	28	40	48	58	72	84	96	108	120	136
<b>D</b>	22	34	40	46	58	70	80	92	104	116
<b>E</b>	6	8	10	11	12	16	18	20	24	24
<b>F</b>	46	58	66	76	90	102	114	126	138	154
<b>G</b>	42	54	60	66	78	90	102	114	126	138
<b>H</b>	13 $\frac{3}{8}$	16 $\frac{3}{8}$	22 $\frac{1}{2}$	26 $\frac{1}{4}$	29 $\frac{1}{2}$	35 $\frac{1}{4}$	39	47 $\frac{1}{4}$	52 $\frac{3}{8}$	63 $\frac{3}{8}$
<b>I</b>	10 $\frac{3}{8}$	12 $\frac{3}{8}$	17	20 $\frac{1}{2}$	22 $\frac{3}{4}$	27	30	37 $\frac{1}{2}$	40 $\frac{3}{4}$	49 $\frac{3}{4}$
<b>J</b>	18	22	28	34	38	45	50	62	66	80
<b>K</b>	6	8	10	10	12	16	19	20	24	24
<b>L</b>	84	87	89	104	112	118	122	124	128	128
<b>M</b>	64	64	70	77	89	102	102	102	114	114
<b>N</b>	35	49	55	62	76	88	103	116	128	142
<b>O</b>	38	52	58	65	79	91	106	119	131	145
<b>P</b>	14	16	22	26	30	36	42	50	54	66
<b>Q</b>	45	50	61	64	68	72	78	86	93	103
<b>R</b>	35	44	55	65	75	85	94	108	120	141
<b>S</b>	46	52	59	69	72	79	82	97	100	110
<b>T</b>	36	48	54	60	72	84	96	108	120	132
<b>WHEEL DIA.</b>	12 $\frac{1}{4}$	15	20	24 $\frac{1}{2}$	27	33	36 $\frac{1}{2}$	44 $\frac{1}{2}$	49	60
<b>CFM x 1000</b>	1-2	2-4	4-6	6-8	8-12	12-18	18-24	24-30	30-40	40-50
<b>RECIRC. GPM</b>	7	15	25	35	45	75	105	135	175	225
<b>MAKE-UP GPM</b>	0.7	1.5	2.0	3.0	4.0	7.0	10.0	13.0	17.0	22.0
<b>HT OP. WT.</b>	388	745	1110	1570	2690	4085	5670	7595	11790	16040
<b>HT SHIP WT.</b>	220	385	550	770	1210	1925	2750	3795	5390	7040
<b>VT OP. WT.</b>	318	660	1060	1500	2630	3910	5470	7400	11650	15800
<b>VT SHIP WT.</b>	150	300	500	700	1150	1750	2550	3600	5250	6800

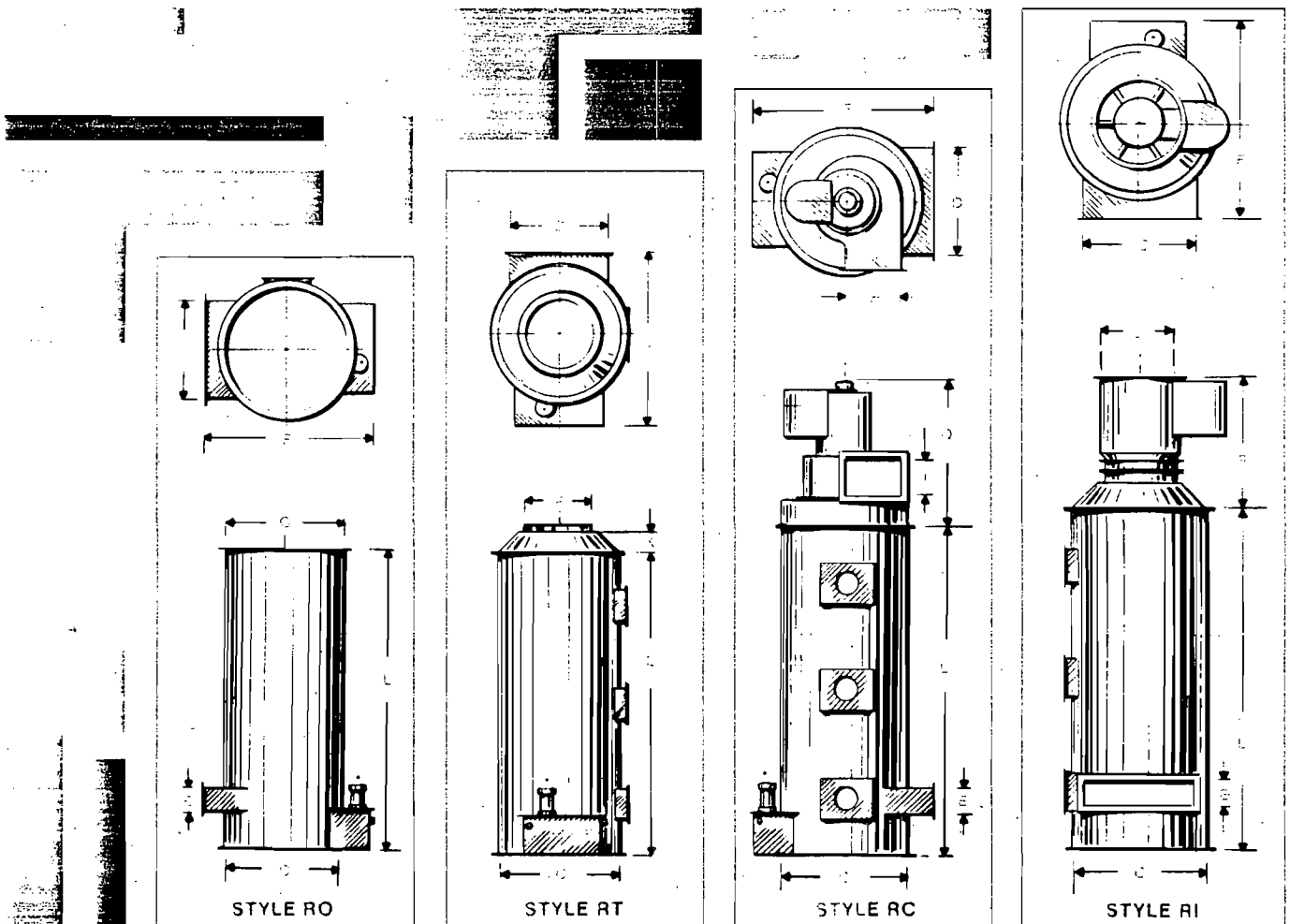



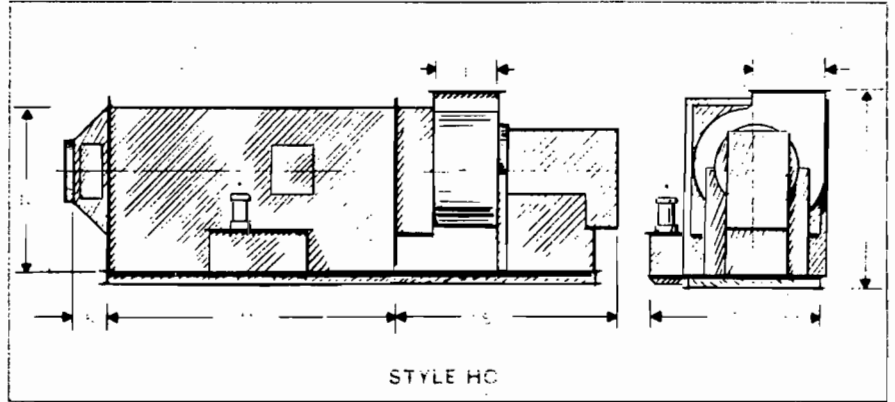
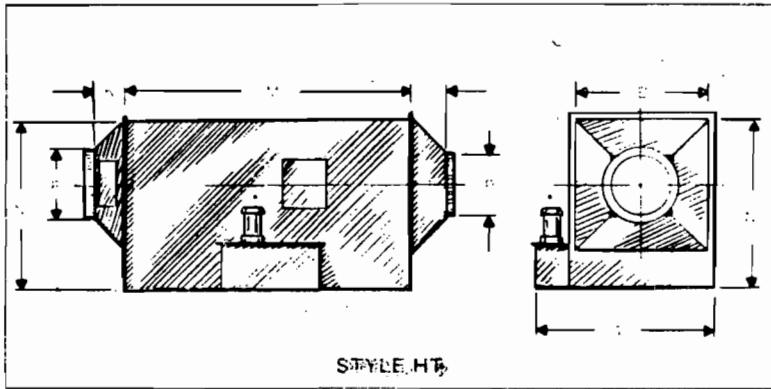

\*May require one or more pumps.

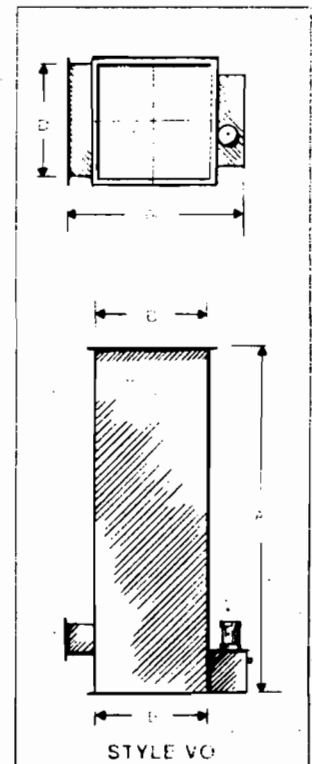
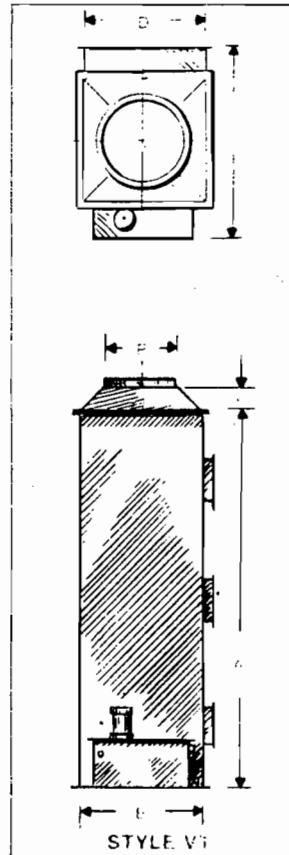
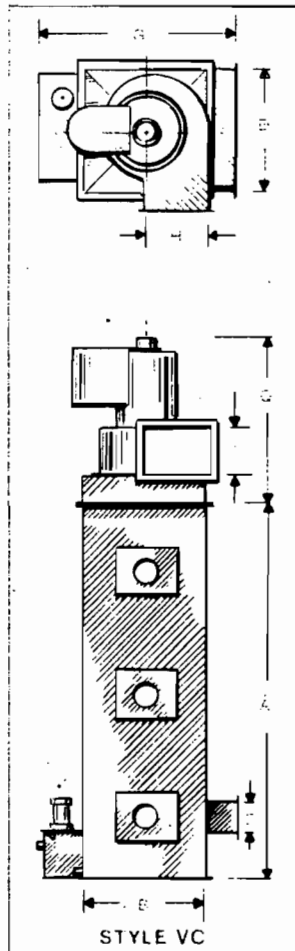
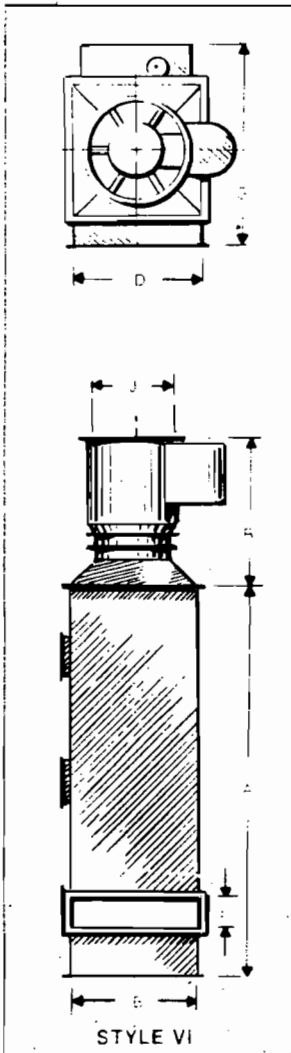

## **COMPUTERIZED PACKING MEDIA SELECTION**

The most common mistake made by scrubber manufacturers today is the use of only one type of packing media for all types of contaminant removal. Beverly Pacific Corporation scrubbers are designed with a computer program assist to determine the most beneficial packing media to achieve high removal efficiency coupled with low pressure drop providing the user with the ultimate in lower operating costs consistent with the contaminant removal requirements.

## **SCRUBBER CONFIGURATIONS**

Beverly Pacific Corporation manufactures scrubbers of both crossflow and counter-current configurations.

The CROSSFLOW design is of low profile, rectangular shape wherein the contaminated air stream moves horizontally through the packing media and is scrubbed by the liquid flowing downward through the packing. This configuration is ideal for roof-top mounting and is available in ten (10) standard sizes with or without integral centrifugal fans.

The COUNTER-CURRENT design is offered in two (2) configurations, round or rectangular. While the round tower unit is the most economical in initial cost, the rectangular tower unit permits larger CFM volume using the same amount of floor space. In the counter-current design, the contaminated airstream flows up through the packing media and is scrubbed by the liquid flowing downward. The round and rectangular tower units are each offered in ten (10) sizes and are available with or without integral inline or centrifugal fans.

## **SCRUBBER MAKE-UP WATER CONSUMPTION**

Beverly Pacific's scrubber design is based on a scrubbing liquid recirculation rate of 5 GPM per 1000 CFM of contaminated air. Of that 5 GPM, losses due to absorption and/or evaporation range from 0.2 GPM to 0.6 GPM, depending on inlet gas temperature and gas stream dust load.

## **ENTRAINMENT SEPARATION**

The unique design of Beverly Pacific's mist eliminator section provides up to 99+<sup>cc</sup>% moisture particle entrapment at a pressure drop of approximately 0.5" W.G.

## **CONSTRUCTION**

The structural housings are fabricated of Fiberglass Reinforced Plastic (FRP) materials which provide structural strength, are corrosion-resistant and light in weight. Resin selection depends on the corrosive element involved. Resins can also be of fire-retardant grade if required. Our construction technique employs the use of female molds resulting in an extremely smooth, attractive, gelcoated exterior surface (note the upper right photo on the facing page). Beverly Pacific Corporation's construction methods meet or exceed the requirements of NBS-PS 15-69 for custom contact-molded reinforced polyester chemical resistant process equipment.

## **OPTIONAL EQUIPMENT, FITTINGS AND ACCESSORIES**

FITTINGS, such as drain, overflow, make-up water, access doors, etc. can usually be located to facilitate installation and maintenance.

RECIRCULATION RESERVOIR(S) are normally an integral part of the scrubber but, if required, can be furnished for remote installation.

RECIRCULATION PUMP(S) can be located within the built-in reservoir, but can also be installed in remote reservoir units.

SPECIAL RESERVOIR(S) can be furnished in applications where it is necessary to remove non-soluble particulate accumulation to prevent pump damage and minimize maintenance.

pH CONTROL SENSING/METERING equipment can be provided where contaminate absorption requires the addition of acid or caustic to the recirculated scrubbing liquid.

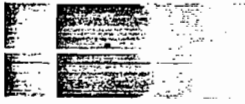
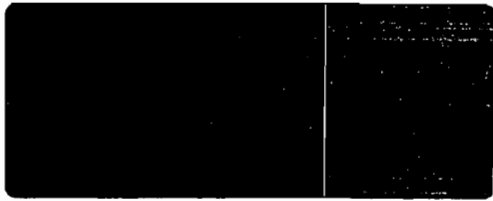

**BEVERLY PACIFIC CORPORATION**

*Industrial Systems Division*

# EXHAUST FANS

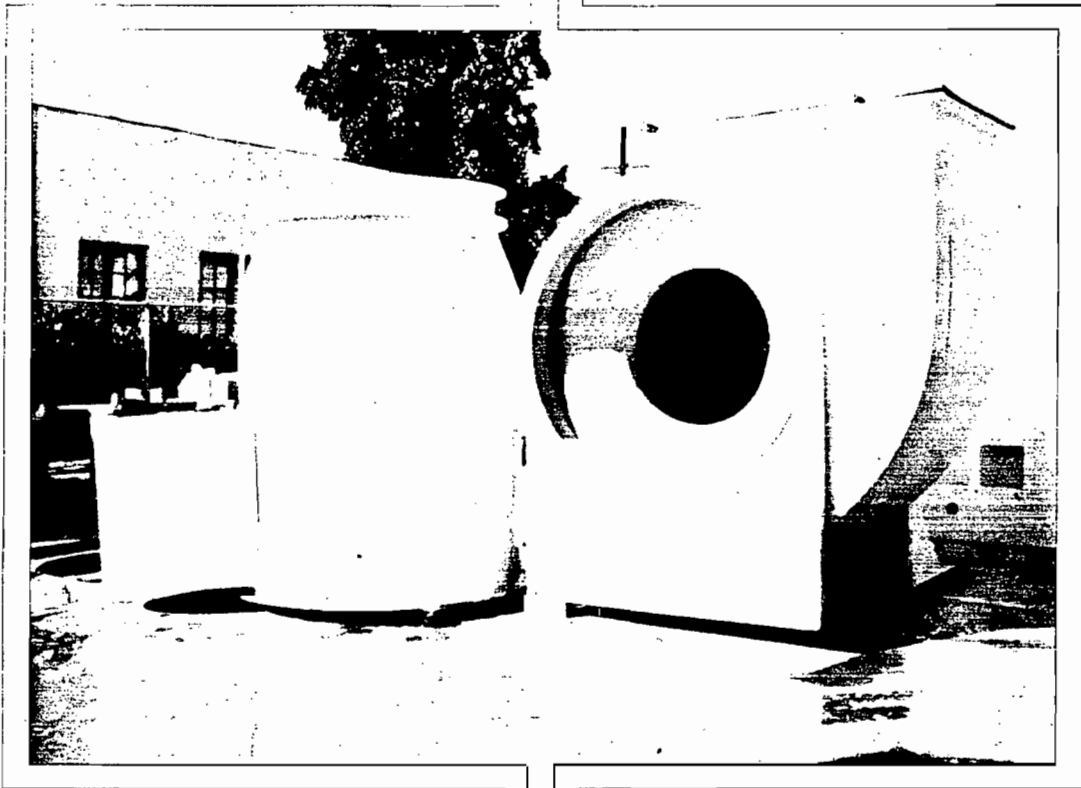

FIBERGLASS REINFORCED PLASTIC

## EXHAUST FAN INTRODUCTION

Beverly Pacific's complete line of centrifugal and inline exhaust fans have proven their reliability with years of successful, continuous corrosive service throughout the nation and around the world.

Our solid "FRP" construction defies corrosion and each is designed to provide smooth, quiet and maintenance-free operation . . . this superior combination permits peak performance with the lowest possible power consumption.

A wide selection of standard models, types and sizes are available to meet your specific requirements.

## FAN WHEEL SUPERIORITY

The Beverly Pacific fan wheels are fabricated of corrosion-resistant Fiberglass Reinforced Plastic (FRP) materials. The fan wheel design is that of a "backward curve blade," Class II construction, and are available in standard sizes of 12¼" through 66" diameters.

All of Beverly Pacific's fan wheels are both statically and dynamically balanced and run on a test stand prior to final assembly to insure continuous, vibration-free performance.

Every surface in contact with the air stream is corrosion resistant. The steel hub (providing the positive-lock connection to the drive shaft) is totally encapsulated in the wheel laminate and even the weight added during the wheel balancing process is corrosion resistant, Fiberglass Reinforced Plastic materials.

Should your particular requirement involve moving a volume of only a few hundred CFM at ¼" S.P. or over 80,000 CFM at 6" S.P., Beverly Pacific has a proven standard size to meet your requirement.

## EXHAUST FANS STANDARD AND OPTIONAL EQUIPMENT

Standard Equipment: Beverly Pacific's centrifugal fans are equipped with a scroll bottom drain and flanged discharge outlet, and are furnished with a purchaser's choice of twelve (12) discharge outlet directions and a choice of right or left fan wheel rotation. Both of our fan styles, centrifugal and inline, are equipped with an OSHA approved belt guard and powered by 230-460/30/60 Hz motors . . . totally enclosed, fan-cooled, (TEFC) up to 20 horsepower, and Multi-guard motors are furnished when horsepower requirements are 25 or larger. Also, as standard equipment, Beverly Pacific furnishes the following list of first-line, top quality drive components which were selected based on motor horsepower, RPM, tip speed and weight of fan wheel, with a safety factor of 1.3 times the motor horsepower.

- a. BEARINGS — Beverly Pacific furnishes Dodge-Type K pillow blocks on the inline model. These Dodge bearings have Timken-tapered roller bearings, are fully self-aligning and designed to meet the stringent demands of power transmission. Based on radial and thrust load computations, bearing life expectancy is in excess of 100,000 hours.
- b. SHEAVES — Beverly Pacific Corporation furnishes Dodge sheaves, which are cast from the finest quality gray iron and machined to rigid quality control specifications. Groove design and spacing conforms to ASA, MPTA and RMA standards. These sheaves are equipped with Taper-Lock bushings, a superior mounting well recognized and widely used in industry.
- c. V-BELTS — Beverly Pacific furnishes Dodge Sealed-Life Belts, Type A, B and C which have a longer wearing protective cover, crowned top, concave sidewall, exceptional stability and an improved cord section which prevents failures caused by cord separation.
- d. WHEEL BACKING PLATES — Beverly Pacific uses Rex taper-lock, single-duty, Type B, steel sprocket, in the backing plate of all FRP fan wheels. This steel sprocket is completely embedded and encased with FRP materials to prevent corrosion attack.
- e. DRIVE SHAFTS — Beverly Pacific uses ground and polished, 1045 TGP shafting rounds, as produced by Inland Steel. This medium carbon steel is used because of its greater strength and hardness. The mechanical properties, based on ¾" — 1¼" diameter round bars of 1045, include a tensile strength of 98,000 PSI, yield strength of 59,000 PSI and a Brinell Hardness of 212.

### BEVERLY PACIFIC CORPORATION CENTRIFUGAL FAN CHARACTERISTIC CURVE

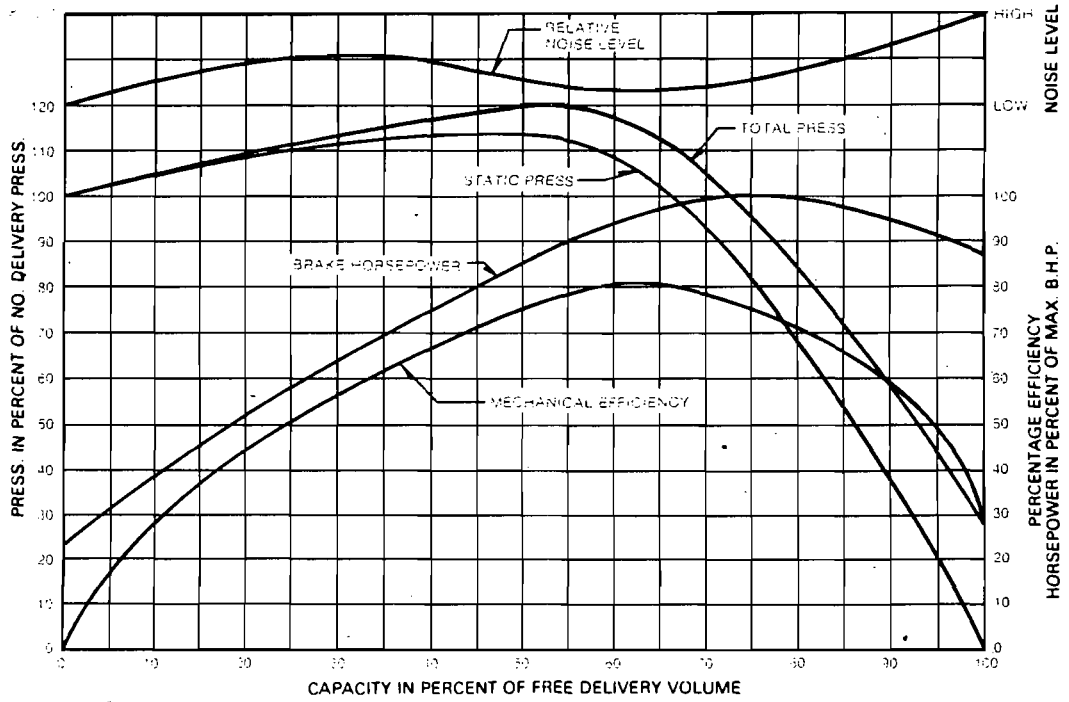

### BEVERLY PACIFIC CORPORATION INLINE FAN CHARACTERISTIC CURVE

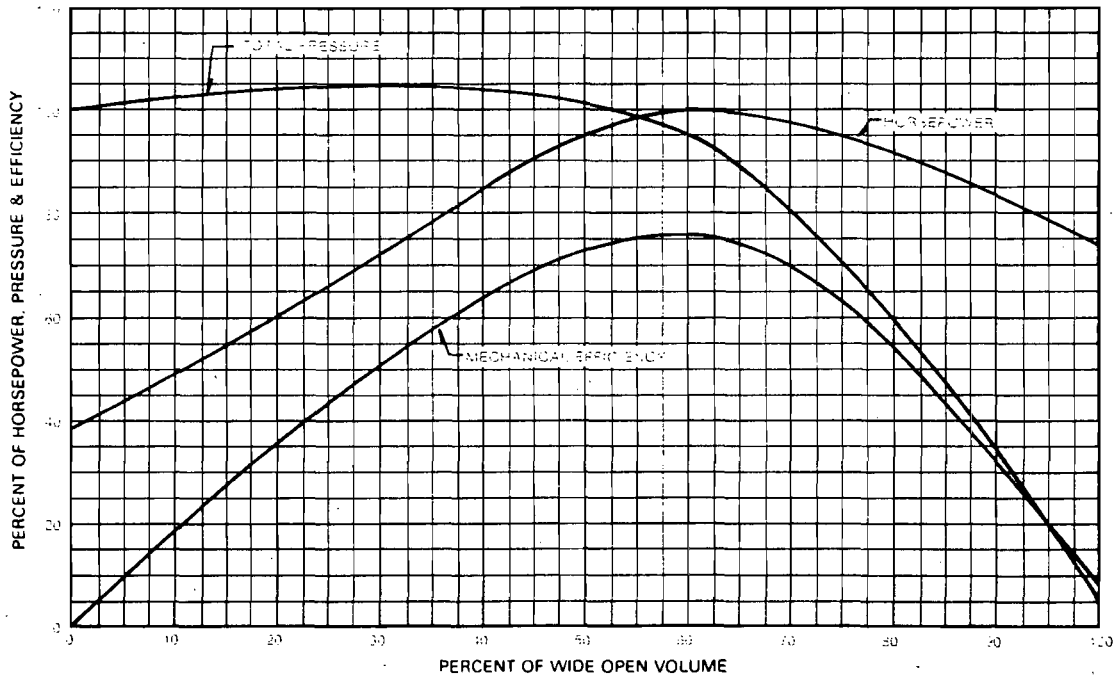

**CENTRIFUGAL INDUSTRIAL EXHAUST FANS**

	CB-12	CB-13	CB-15	CB-16	CB-18	CB-20	CB-22	CB-24	CB-27	CB-30	CB-33	CB-36
<b>MID-RANGE CFM RECOMMENDED</b>	2,150	2,625	3,200	3,900	4,750	5,800	7,075	8,650	10,550	12,875	15,700	19,000
<b>FAN WHEEL DIAMETER</b>	12 $\frac{1}{4}$ "	13 $\frac{1}{2}$ "	15"	16 $\frac{1}{2}$ "	18 $\frac{1}{4}$ "	20"	22 $\frac{1}{4}$ "	24 $\frac{1}{2}$ "	27"	30"	33"	36 $\frac{1}{2}$ "
<b>A</b>	13 $\frac{1}{2}$ "	14 $\frac{1}{2}$ "	16 $\frac{1}{2}$ "	18 $\frac{1}{4}$ "	20"	22"	24 $\frac{1}{2}$ "	26"	29 $\frac{1}{4}$ "	32 $\frac{1}{4}$ "	36"	40"
<b>B</b>	10 $\frac{3}{8}$ "	11 $\frac{1}{8}$ "	12 $\frac{3}{8}$ "	14 $\frac{3}{8}$ "	15"	17"	18 $\frac{3}{4}$ "	20 $\frac{1}{2}$ "	22 $\frac{3}{4}$ "	25"	27"	30"
<b>C</b>	13 $\frac{3}{8}$ "	14 $\frac{3}{8}$ "	16 $\frac{3}{8}$ "	18 $\frac{3}{8}$ "	20"	22 $\frac{1}{2}$ "	24"	26 $\frac{1}{4}$ "	29 $\frac{1}{2}$ "	32"	35 $\frac{1}{4}$ "	39"
<b>D</b>	34 $\frac{1}{4}$ "	35 $\frac{1}{4}$ "	40 $\frac{1}{8}$ "	42 $\frac{1}{8}$ "	45"	47 $\frac{3}{4}$ "	54"	57 $\frac{1}{4}$ "	61 $\frac{1}{2}$ "	64 $\frac{3}{4}$ "	66 $\frac{3}{4}$ "	69 $\frac{3}{4}$ "
<b>E</b>	22 $\frac{1}{4}$ "	22 $\frac{1}{2}$ "	27 $\frac{1}{4}$ "	29 $\frac{3}{4}$ "	32 $\frac{3}{8}$ "	36 $\frac{1}{2}$ "	39 $\frac{1}{4}$ "	43 $\frac{1}{4}$ "	49"	53"	58 $\frac{1}{4}$ "	65"
<b>F</b>	15"	16"	18"	19"	20"	23"	26"	28"	30"	33"	36"	51"
<b>G</b>	11"	11 $\frac{1}{2}$ "	12 $\frac{1}{2}$ "	14"	15 $\frac{1}{2}$ "	17 $\frac{1}{4}$ "	19"	21 $\frac{1}{2}$ "	23"	25 $\frac{1}{2}$ "	28 $\frac{1}{2}$ "	30 $\frac{1}{2}$ "
<b>H</b>	13 $\frac{3}{8}$ "	14 $\frac{3}{8}$ "	15 $\frac{3}{8}$ "	17 $\frac{3}{8}$ "	18"	21"	22 $\frac{3}{4}$ "	24 $\frac{1}{2}$ "	26 $\frac{3}{4}$ "	29"	31"	34"
<b>I</b>	16"	16"	18 $\frac{1}{4}$ "	18 $\frac{3}{4}$ "	20"	20 $\frac{1}{2}$ "	23"	23"	25"	26"	26"	26"
<b>J</b>	3"	3"	4"	4"	4"	4"	6"	6"	6"	6"	6"	6"
<b>K</b>	9 $\frac{1}{4}$ "	10 $\frac{1}{4}$ "	11 $\frac{1}{4}$ "	12 $\frac{1}{2}$ "	13 $\frac{1}{2}$ "	15"	16"	18"	20 $\frac{1}{2}$ "	22"	24"	27"
<b>L</b>	9 $\frac{1}{4}$ "	10 $\frac{1}{4}$ "	11 $\frac{1}{4}$ "	12 $\frac{1}{2}$ "	13 $\frac{1}{2}$ "	15"	16"	18"	20 $\frac{1}{2}$ "	22"	24"	27"
<b>M</b>	3 $\frac{1}{2}$ "	3 $\frac{1}{4}$ "	4 $\frac{1}{4}$ "	4 $\frac{1}{2}$ "	5"	5 $\frac{1}{4}$ "	6 $\frac{3}{8}$ "	6 $\frac{3}{8}$ "	7 $\frac{3}{8}$ "	8 $\frac{1}{4}$ "	9 $\frac{1}{2}$ "	10 $\frac{1}{2}$ "
<b>DRIVE SHAFT DIAMETER</b>	1"	1"	1 $\frac{1}{16}$ "	1 $\frac{1}{16}$ "	1 $\frac{1}{16}$ "	1 $\frac{1}{16}$ "	1 $\frac{1}{16}$ "	1 $\frac{1}{16}$ "	1 $\frac{1}{16}$ "	1 $\frac{1}{16}$ "	1 $\frac{1}{16}$ "	2 $\frac{1}{16}$ "
<b>SHIPPING WEIGHT POUNDS</b>	170	205	230	400	550	600	650	720	850	1,000	1,380	1,600

**DESIGNATION OF DIRECTION OF ROTATION AND DISCHARGE**

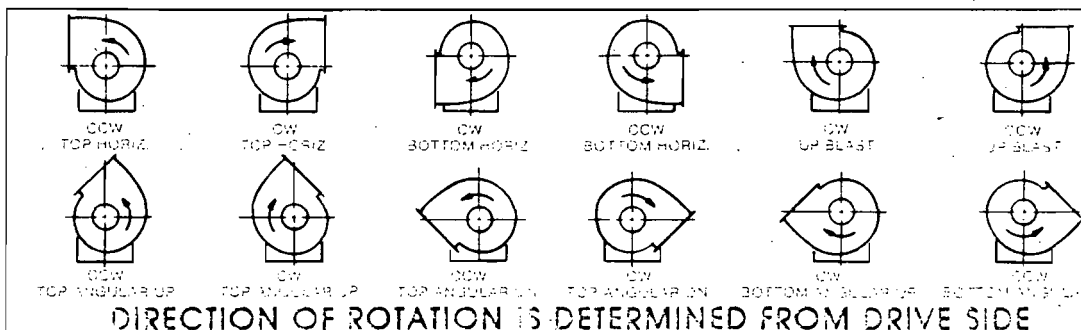

**INLINE EXHAUST FANS**

	IB-12	IB-15	IB-18	IB-20	IB-22	IB-24	IB-27	IB-30	IB-33	IB-36	IB-40	IB-44
<b>MID-RANGE CFM RECOMMENDED</b>	2,550	3,842	4,648	5,614	6,948	8,424	10,242	12,644	15,300	18,718	22,761	27,000
<b>FAN WHEEL DIAMETER</b>	12 $\frac{1}{4}$ "	15"	18 $\frac{1}{4}$ "	20"	22 $\frac{1}{4}$ "	24 $\frac{1}{2}$ "	27"	30"	33"	36 $\frac{1}{2}$ "	40 $\frac{1}{2}$ "	44"
<b>P</b>	21"	28"	32 $\frac{1}{2}$ "	36 $\frac{1}{2}$ "	40"	47"	53"	55"	58"	63 $\frac{3}{4}$ "	70"	78"
<b>Q</b>	14"	16"	20"	22"	24"	26"	30"	32"	36"	42"	46"	50"
<b>R</b>	18"	22"	26"	28"	32"	34"	38"	42"	45"	50"	56"	62"
<b>S</b>	2"	2"	2"	2"	2"	3"	3"	3"	3"	3"	3"	3"
<b>T</b>	23"	28"	31"	32"	34"	35"	37"	39"	40 $\frac{1}{2}$ "	45"	52"	60"
<b>U</b>	2"	2"	2"	2"	2"	3"	3"	3"	3"	3"	3"	3"
<b>DRIVE SHAFT DIAMETER</b>	1"	1 $\frac{1}{16}$ "	1 $\frac{1}{16}$ "	1 $\frac{1}{16}$ "	1 $\frac{1}{16}$ "	1 $\frac{1}{16}$ "	1 $\frac{1}{16}$ "	1 $\frac{1}{16}$ "	1 $\frac{1}{16}$ "	1 $\frac{1}{16}$ "	2 $\frac{1}{16}$ "	2 $\frac{1}{16}$ "
<b>SHIPPING WEIGHT POUNDS</b>	90	130	290	320	350	380	450	525	730	850	1,110	1,400

**DIMENSIONAL CHART**

	CB-40	CB-44	CB-49	CB-54	CB-60	CB-66	
9,150	23,375	28,525	34,775	42,450	51,775	63,175	MID-RANGE CFM RECOMMENDED
16 1/2	40 1/4	44 1/2	49	54 1/4	60	66	FAN WHEEL DIAMETER
10	44 1/2	49	54	60	66	72	A
10	34 1/2	37 1/2	40 3/4	44 3/4	49 3/4	54 3/4	B
19	43	47 1/4	52 3/8	57 3/8	63 3/8	70 3/4	C
19 3/4	79 3/4	84 3/4	88	93	97 3/8	104 3/8	D
15 1/4	72 1/2	79 1/2	88 1/4	97	106	119	E
11 1/2	42	49 3/4	49	54	59 1/2	64	F
10 1/2	34 1/2	37 1/2	41	46	50 1/2	55	G
14	40 1/2	43 1/2	46 3/4	50 3/4	53 3/4	60 3/4	H
16	27 1/2	29 1/2	29 1/2	31 1/4	33 1/4	33	I
3	8	8	8	8	8	8	J
27	25 3/4	26 3/4	30	34	37	40	K
27	25 3/4	26 3/4	30	34	37	40	L
10 1/4	11 1/4	12 1/4	14 5/16	15 5/16	17 5/16	19 5/16	M
2 3/16	2 3/16	2 7/16	2 7/16	2 15/16	2 15/16	2 15/16	DRIVE SHAFT DIAMETER
1,610	2,050	2,300	2,650	3,110	3,525	4,000	SHIPPING WEIGHT POUNDS

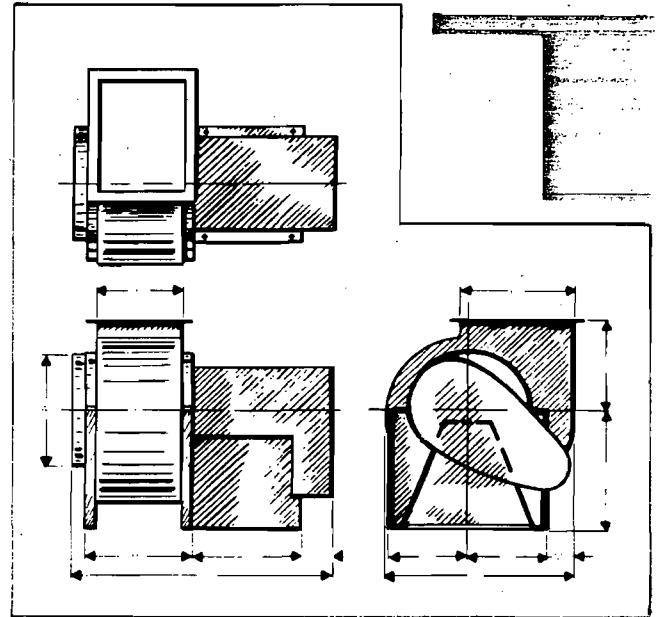

Beverly Pacific's FRP constructed fans have a Type "A" classification for spark resistance.

**STANDARD CLASSIFICATIONS FOR SPARK RESISTANT CONSTRUCTION**

TYPE	CONSTRUCTION
A	All parts of the fan in contact with the air or gas being handled shall be made of non-ferrous material.
B	The fan shall have an entirely non-ferrous wheel and non-ferrous ring about the opening through which the shaft passes.
C	The fan shall be so constructed that a shift of the wheel or shaft will not permit two ferrous parts of the fan to rub or strike.

**DIMENSIONAL CHART**

	IB-49	IB-54	IB-60	IB-66	
7,822	33,733	41,349	50,579	61,201	MID-RANGE CFM RECOMMENDED
4 1/2	49	54 1/4	60	66	FAN WHEEL DIAMETER
8"	84"	93"	104"	116"	P
10"	54"	60"	66"	72"	Q
12"	66"	72"	80"	88"	R
1"	3"	3"	3"	3"	S
13"	65"	68"	72"	76"	T
1"	3"	3"	3"	3"	U
7/16	2 7/16	2 15/16	2 15/16	2 15/16	DRIVE SHAFT DIAMETER
1,250	1,420	1,650	1,800	2,100	SHIPPING WEIGHT POUNDS

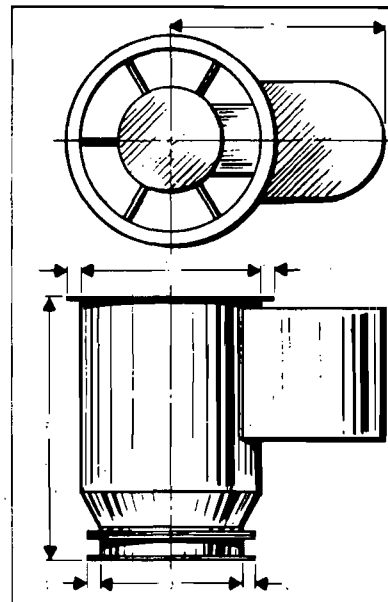





*HARRIS SEMICONDUCTOR*  
*AIR PERMIT - BUILDING 63*  
*ATTACHMENT E*  
*SITE LOCATION MAPS*

BEST AVAILABLE COPY

# Harris Semiconductor Complex

SCRUBBER LOCATIONS

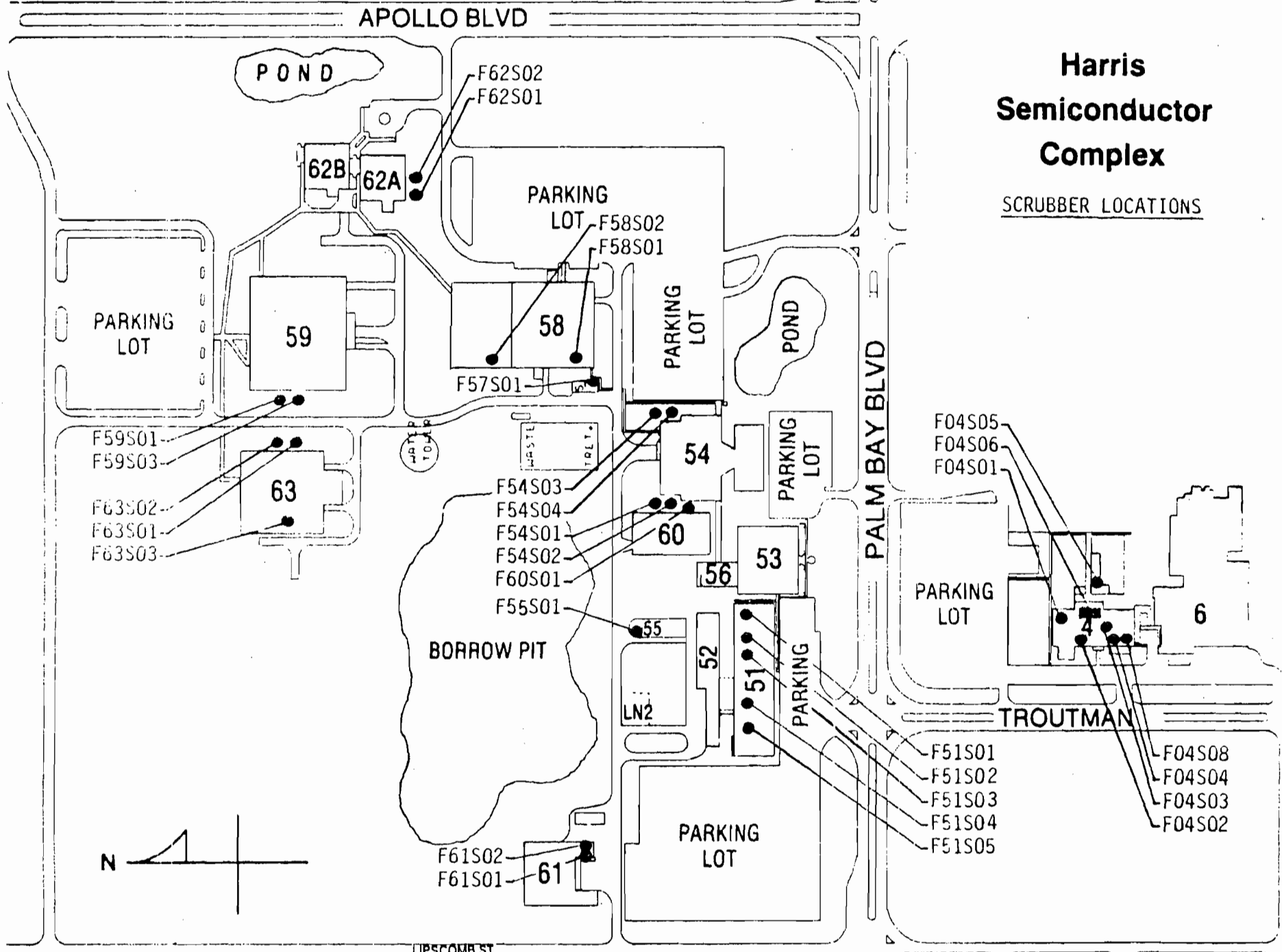

APOLLO BLVD

POND

62B

62A

PARKING LOT

58

PARKING LOT

POND

PARKING LOT

59

F57S01

54

PARKING LOT

F59S01  
F59S03

63

F63S02  
F63S01  
F63S03

F54S03  
F54S04  
F54S01  
F54S02  
F60S01  
F55S01

60

53

PARKING LOT

BORROW PIT

55

56

53

PARKING LOT

6

F04S05  
F04S06  
F04S01

N

LN2

52

51

51

PARKING LOT

TROUTMAN

F51S01  
F51S02  
F51S03  
F51S04  
F51S05

F04S08  
F04S04  
F04S03  
F04S02

F61S02  
F61S01

61

LIPSCOMB ST

PALM BAY BLVD

HARRIS SEMICONDUCTOR  
SCRUBBER LOCATIONS  
BUILDING 63

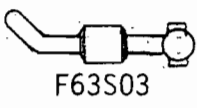
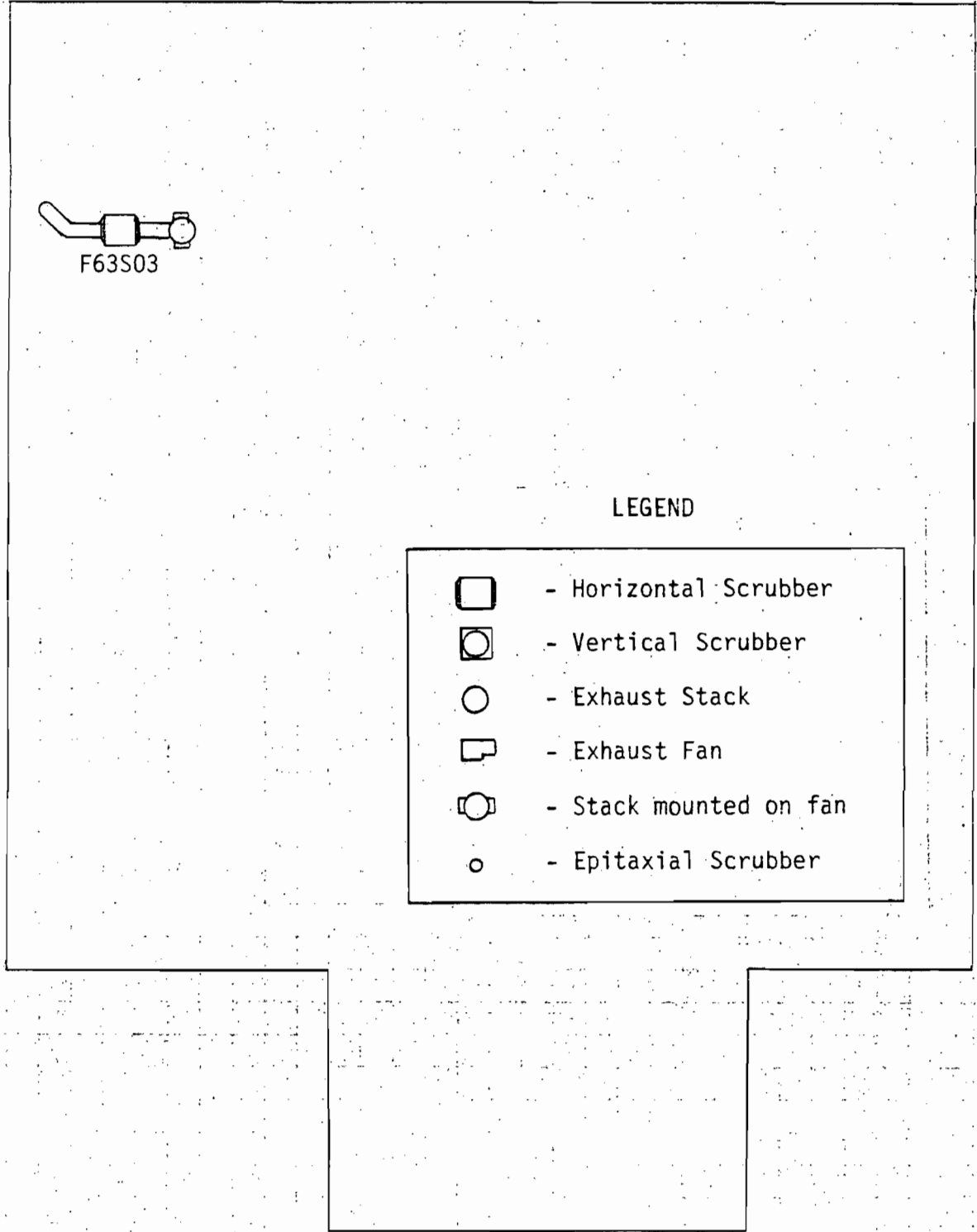
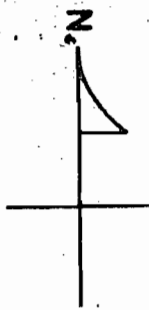

F63S03

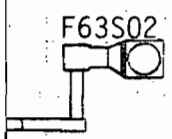



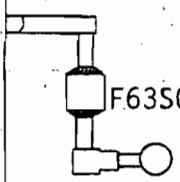



F63S02



F63S01

LEGEND

-  - Horizontal Scrubber
-  - Vertical Scrubber
-  - Exhaust Stack
-  - Exhaust Fan
-  - Stack mounted on fan
-  - Epitaxial Scrubber



PM  
11-23-88  
Melbourne, FL

Main File 077

RECEIVED  
DER - MAIL ROOM  
1988 NOV 28 AM 11:04

November 16, 1988

Mr. Claire Fancy  
Deputy Chief  
Bureau of Air Quality Management  
Florida Department of Environmental Regulation  
Twin Towers Office Building  
2600 Blair Stone Road  
Tallahassee, FL 32399-2400

1031

Subject: Additional funding; Buildings 51 & 62  
Consolidated air permit application fees

Dear Mr. Fancy:

In accordance with the revised Permit Application Fee Schedule (effective October 3, 1988), enclosed are two supplemental checks for the additional construction permit application fees.

- Based on the potential emissions of 25 or more tons per year, but less than 50 tons per year of any single pollutant, \$250.00 additional funding is enclosed to meet the \$500.00 processing fee for the consolidated air permit application for building 51, as per 17-4.050(4d).

- Based on the potential emissions of less than 25 tons per year any single pollutant, \$100.00 additional funding is enclosed to meet the \$200.00 processing fee for the consolidated air permit application for building 51, as per 17-4.050(4e).

1031

Please call me at (407) 729-4061 if you have any questions.

Sincerely,

Nancy Baldisserotto  
Environmental Engineer

THE FIRST NATIONAL BANK OF ATLANTA  
AUGUSTA, GA.



HARRIS 00149

64-1327  
611

623695

HARRIS CORPORATION

SEMICONDUCTOR GROUP

PAY \*\*\*\*\*250 DOLLARS AND 00\*\*\* CENTS

000000	11	14	88
ACCT. NO.	PAYABLE DATE		
CHECK NUMBER			

*****250	00***
CHECK AMOUNT	

TO ORDER OF

FLORIDA DEPT. OF ENVIRONMENTAL  
REGULATION  
2600 BLAIR STONE ROAD  
TALLAHASSEE, FL 32399-2400

HARRIS SEMICONDUCTOR

COUNTERSIGNED

AUTHORIZED SIGNATURE

THE FIRST NATIONAL BANK OF ATLANTA  
AUGUSTA, GA.



HARRIS 00149

64-1327  
611

623696

HARRIS CORPORATION

SEMICONDUCTOR GROUP

PAY \*\*\*\*\*100 DOLLARS AND 00\*\*\* CENTS

000000	11	14	88
ACCT. NO.	PAYABLE DATE		
CHECK NUMBER			

*****100	00***
CHECK AMOUNT	

TO ORDER OF

FLORIDA DEPARTMENT OF ENVIRONMENTAL  
REGULATION  
2600 BLAIR STONE ROAD  
TALLAHASSEE, FL 32399-2400

HARRIS SEMICONDUCTOR

COUNTERSIGNED

AUTHORIZED SIGNATURE

D1-000-S1589

HARRIS SEMICONDUCTOR

00034379

VOUCHER NUMBER	INVOICE NUMBER	PURCHASE ORDER	INVOICE DATE	AMOUNT	DISCOUNT	NET AMOUNT
118349	040488		04-04-88	250.00	.00	250.00
T O T A L S				250.00	.00	250.00

Betty Adams  
 Sm Wright  
 407-834-0516

REMITTANCE STATEMENT / DETACH BEFORE DEPOSITING

BEST AVAILABLE COPY

HARRIS SEMICONDUCTOR SECTOR



HARRIS CORPORATION  
 SEMICONDUCTOR SECTOR

THE FIRST NATIONAL BANK OF ATLANTA  
 AUGUSTA, GEORGIA

64-122  
 611

034379

00112

PAY

DATE

04/15/88

CHECK NO.

00034379

NET AMOUNT

\*\*\*\*\*250.00

TWO HUNDRED FIFTY AND 00/100 DOLLARS

TO THE  
 ORDER  
 OF

DEPT ENVIRONMENTAL REGULATION  
 3319 MAGUIRE BLVD., SUITE 232  
 ORLANDO, FL 32803-3767

HARRIS CORPORATION  
 SEMICONDUCTOR SECTOR

COUNTERSIGNED

AUTHORIZED SIGNATURE

VOUCHER NUMBER	INVOICE NUMBER	PURCHASE ORDER	INVOICE DATE	AMOUNT	DISCOUNT	NET AMOUNT
145732	080488		08-04-88	100.00	.00	100.00
		BLDG. 62				
				404-1900 334-4874		
		TOTALS		100.00	.00	100.00

REMITTANCE STATEMENT / DETACH BEFORE DEPOSITING

**BEST AVAILABLE COPY**

HARRIS SEMICONDUCTOR SECTOR



THE FIRST NATIONAL BANK OF ATLANTA  
AUGUSTA, GEORGIA

64-1327  
611  
00112 042494

PAY

**DATE**  
08/26/88

**CHECK NO.**  
00042494

**NET AMOUNT**  
\*\*\*\*\*100.00

ONE HUNDRED AND 00/100 DOLLARS

TO THE ORDER OF

DEPARTMENT OF ENVIRONMENTAL  
REGULATION  
BUREAU OF AIR QUALITY MANAGE  
2600 BLAIR STONE RD  
TALLAHASSEE, FL

HARRIS CORPORATION  
SEMICONDUCTOR SECTOR

32501

COUNTERSIGNED  
*[Signature]*  
AUTHORIZED SIGNATURE

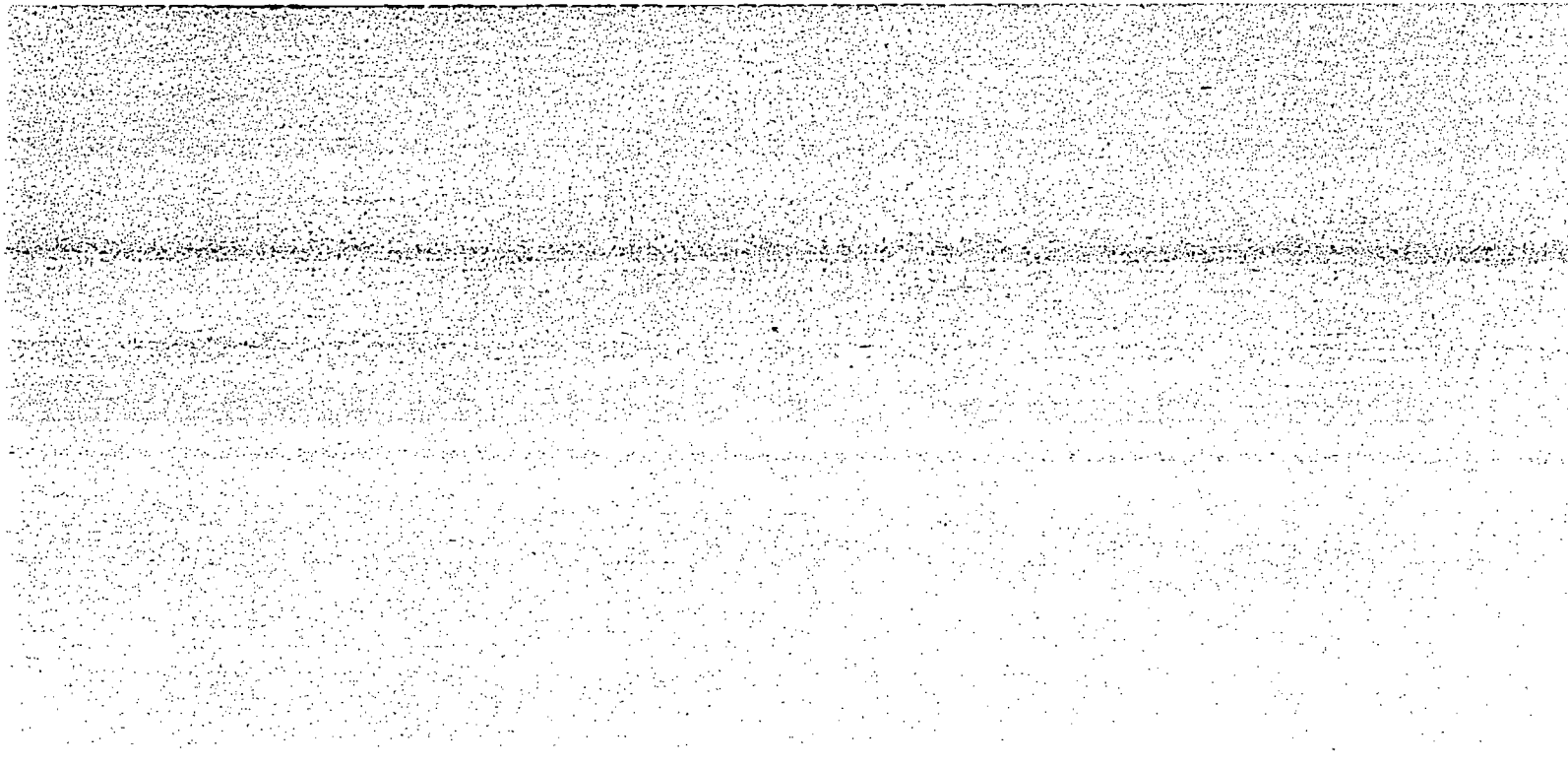

Best Available Copy



Purulator courier®  
733058243  
Pkg. 2 of 2

RECEIVED

NOV 28 1988

DER-BAQM

RECEIVED  
DER - MAIL ROOM  
1988 NOV -7 AM 11:26

FS-JRK-061-89

November 3, 1988

Mr. C. H. Fancy  
Deputy Bureau Chief  
Department of Environmental Regulations  
Bureau of Air Quality Mangement  
2600 Blair Stone Road  
Tallahassee, Florida 32301

REF: HARRIS SEMICONDUCTOR  
Building 62 Consolidated Air Permit

Dear Mr. Fancy:

On February 17, 1988 representatives from Harris and the Florida DER met in Orlando to discuss the status of air permits at Harris Semiconductor's facility in Palm Bay. At that meeting it was agreed that Harris would submit modified air permits. The purpose of the permit modifications was as follows:

1. Consolidate permits on a by building basis to reduce the existing number of permits.
2. To accurately quantify the current air emissions.

Enclosed is the original and two (2) copies of the modified permit applications for Semiconductor's Building 62.

If you should have any questions about the enclosed information, please feel free to contact me at (407) 724-7467.

Sincerely,

J. R. Kolanek, Manager  
Environmental Services

/pgc

Enclosure

cc: C. Collins  
Central Florida District

RECEIVED

NOV 7 1988

DER-BAQM



11-000-51967		HARRIS SEMICONDUCTOR			00042494	
VOUCHER NUMBER	INVOICE NUMBER	PURCHASE ORDER	INVOICE DATE	AMOUNT	DISCOUNT	NET AMOUNT
145732	030488		08-04-88	100.00	.00	100.00
T O T A L S				100.00	.00	100.00

EMITTANCE STATEMENT / DETACH BEFORE DEPOSITING

**BEST AVAILABLE COPY**

HARRIS SEMICONDUCTOR SECTOR

**HARRIS**  
HARRIS CORPORATION  
SEMICONDUCTOR SECTOR

THE FIRST NATIONAL BANK OF ATLANTA  
AUGUSTA, GEORGIA

64-1327  
611

042494

**DATE**  
08/26/88

**CHECK NO.**  
00042494

**NET AMOUNT**  
\*\*\*\*\*100.00

1Y

100 HUNDRED AND 00/100 DOLLARS

TO THE  
ORDER  
OF

DEPARTMENT OF ENVIRONMENTAL  
REGULATION  
BUREAU OF AIR QUALITY MANAGE  
2800 BLAIR STONE RD  
TALLAHASSEE, FL

HARRIS CORPORATION  
SEMICONDUCTOR SECTOR

32301

COUNTERSIGNED  
*[Signature]*  
AUTHORIZED SIGNATURE





RECEIVED  
DER - MAIL ROOM  
1988 NOV -7 AM 11:27

FS-JRK-059-89

November 1, 1988

Mr. C. H. Fancy  
Deputy Bureau Chief  
Department of Environmental Regulations  
Bureau of Air Quality Management  
2600 Blair Stone Road  
Tallahassee, Florida 32301

RECEIVED

NOV 28 1988

DER - BAQM

REF: HARRIS SEMICONDUCTOR  
Building 51 Consolidated Air Permit

Dear Mr. Fancy:

On February 17, 1988 representatives from Harris and the Florida DER met in Orlando to discuss the status of air permits at Harris Semiconductor's facility in Palm Bay. At that meeting it was agreed that Harris would submit modified air permits. The purpose of the permit modifications was as follows:

1. Consolidate permits on a by building basis to reduce the existing number of permits.
2. To accurately quantify the current air emissions.

Enclosed is the original and two (2) copies of the modified permit applications for Semiconductor's Building 51.

If you should have any questions about the enclosed information, please feel free to contact me at (407) 724-7467.

Sincerely,

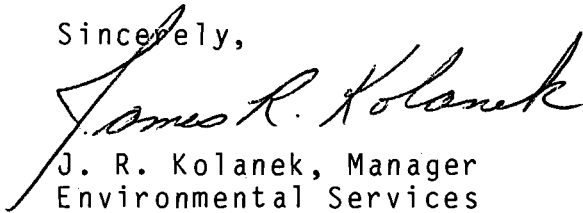
  
J. R. Kolanek, Manager  
Environmental Services

RECEIVED

NOV 7 1988

DER - BAQM

/pgc

Enclosure

cc: C. Collins  
Central Florida District

DEPARTMENT OF ENVIRONMENTAL REGULATION

**ROUTING AND TRANSMITTAL SLIP**

ACTION NO

ACTION DUE DATE

1. TO: (NAME, OFFICE, LOCATION)

*Bruce*

Initial

Date

2.

Initial

Date

3.

Initial

Date

4.

Initial

Date

REMARKS:

*Could you look at these applications from Harris ASAP? I think they've submitted an incorrect fee. If we have to call them, I'd like to be sure what they owe.*

*Thanks*

*you are correct:*

*They owe \$100 & \$250 mon.  
B12, 62 B12, 51*

*Thanks  
Bm*

INFORMATION

Review & Return

Review & File

Initial & Forward

DISPOSITION

Review & Respond

Prepare Response

For My Signature

For Your Signature

Let's Discuss

Set Up Meeting

Investigate & Report

Initial & Forward

Distribute

Concurrence

For Processing

Initial & Return

FROM:

*Patty*

DATE

*11-7-88*

PHONE

01-000-51589

HARRIS SEMICONDUCTOR

00034379

VOUCHER NUMBER	INVOICE NUMBER	PURCHASE ORDER	INVOICE DATE	AMOUNT	DISCOUNT	NET AMOUNT
118349	040488		04-04-88	250.00	.00	250.00
T O T A L S				250.00	.00	250.00

EMITTANCE STATEMENT / DETACH BEFORE DEPOSITING

BEST AVAILABLE COPY

HARRIS SEMICONDUCTOR SECTOR

**HARRIS**

HARRIS CORPORATION  
SEMICONDUCTOR SECTOR

THE FIRST NATIONAL BANK OF ATLANTA  
AUGUSTA, GEORGIA

64-1327  
611

034379

BY

0 HUNDRED FIFTY AND 00/100 DOLLARS

DATE  
04/15/88

CHECK NO  
00034379

NET AMOUNT  
\*\*\*\*\*250.00

TO THE  
ORDER  
OF

DEPT ENVIRONMENTAL REGULATION  
3519 MAGUIRE BLVD., SUITE 232  
ORLANDO, FL 32803-3767

HARRIS CORPORATION  
SEMICONDUCTOR SECTOR

COUNTERSIGNED  
*[Signature]*  
AUTHORIZED SIGNATURE

DEPARTMENT OF ENVIRONMENTAL REGULATION  
**RECEIVED**

WIN TOWERS OFFICE BUILDING  
2600 BLAIR STONE ROAD  
TALLAHASSEE, FLORIDA 32301-8241

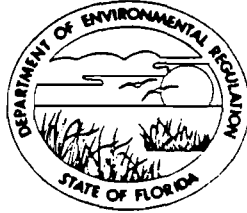

NOV 28 1988

BOB GRAHAM  
GOVERNOR

VICTORIA J. TSCHINKEL  
SECRETARY

DER-BAQM

AC05-157787

APPLICATION TO OPERATE/CONSTRUCT AIR POLLUTION SOURCES

SOURCE TYPE: Stationary [ ] New<sup>1</sup> [x] Existing<sup>1</sup>

APPLICATION TYPE: [ ] Construction [ ] Operation [X] Modification

COMPANY NAME: HARRIS SEMICONDUCTOR COUNTY: Brevard

Identify the specific emission point source(s) addressed in this application (i.e. Lime Kiln No. 4 with Venturi Scrubber; Peaking Unit No. 2, Gas Fired) Building 62

SOURCE LOCATION: Street Palm Bay Road City Palm Bay

UTM: East 17 - 538700 North 17 - 3100900

Latitude 28 ° 01 ' 20 "N Longitude 80 ° 36 ' 10 "W

APPLICANT NAME AND TITLE: J. R. Kolanek, Manager Environmental Services

APPLICANT ADDRESS: M/S 59-006, P.O. Box 883, Melbourne, Florida 32901

SECTION I: STATEMENTS BY APPLICANT AND ENGINEER

A. APPLICANT

I am the undersigned owner or authorized representative\* of Harris Semiconductor

I certify that the statements made in this application for a modified permit are true, correct and complete to the best of my knowledge and belief. Further, I agree to maintain and operate the pollution control source and pollution control facilities in such a manner as to comply with the provision of Chapter 403, Florida Statutes, and all the rules and regulations of the department and revisions thereof. I also understand that a permit, if granted by the department, will be non-transferable and I will promptly notify the department upon sale or legal transfer of the permitted establishment.

\*Attach letter of authorization

Signed: J. R. Kolanek

J. R. Kolanek, Manager Environmental Services  
Name and Title (Please Type)

Date: 10-28-88 Telephone No. (407) 724-7467

B. PROFESSIONAL ENGINEER REGISTERED IN FLORIDA (where required by Chapter 471, F.S.)

This is to certify that the engineering features of this pollution control project have been designed/examined by me and found to be in conformity with modern engineering principles applicable to the treatment and disposal of pollutants characterized in the permit application. There is reasonable assurance, in my professional judgment, that

<sup>1</sup> See Florida Administrative Code Rule 17-2.100(57) and (104)

RECEIVED

the pollution control facilities, when properly maintained and operated, will discharge an effluent that complies with all applicable statutes of the State of Florida and the rules and regulations of the department. It is also agreed that the undersigned will furnish, if authorized by the owner, the applicant a set of instructions for the proper maintenance and operation of the pollution control facilities and, if applicable, pollution sources.

Signed Lawrence R. Hutker

Lawrence R. Hutker  
Name (Please Type)

HARRIS SEMICONDUCTOR  
Company Name (Please Type)

M/S 59-006, P.O. Box 883, Melbourne, Florida 32901  
Mailing Address (Please Type)

Florida Registration No. 35972 Date: 10-28-88 Telephone No. (407) 729-4655

SECTION II: GENERAL PROJECT INFORMATION

1. Describe the nature and extent of the project. Refer to pollution control equipment, and expected improvements in source performance as a result of installation. State whether the project will result in full compliance. Attach additional sheet if necessary.

This is a modification and consolidation of existing air permits.

2. Schedule of project covered in this application (Construction Permit Application Only)

Start of Construction N/A Completion of Construction N/A

3. Costs of pollution control system(s): (Note: Show breakdown of estimated costs only for individual components/units of the project serving pollution control purposes. Information on actual costs shall be furnished with the application for operation permit.)

N/A

4. Indicate any previous DER permits, orders and notices associated with the emission point, including permit issuance and expiration dates.

A0 05-121927; expires 9/14/91

AC 05-104513; expires 6/30/86

E. Requested permitted equipment operating time: hrs/day 24; days/wk 7; wks/yr 52;  
if power plant, hrs/yr \_\_\_\_\_; if seasonal, describe: \_\_\_\_\_  
\_\_\_\_\_  
\_\_\_\_\_

F. If this is a new source or major modification, answer the following questions.  
(Yes or No)

1. Is this source in a non-attainment area for a particular pollutant? No  
a. If yes, has "offset" been applied? \_\_\_\_\_  
b. If yes, has "Lowest Achievable Emission Rate" been applied? \_\_\_\_\_  
c. If yes, list non-attainment pollutants. \_\_\_\_\_

2. Does best available control technology (BACT) apply to this source?  
If yes, see Section VI. No

3. Does the State "Prevention of Significant Deterioration" (PSD)  
requirement apply to this source? If yes, see Sections VI and VII. No

4. Do "Standards of Performance for New Stationary Sources" (NSPS)  
apply to this source? No

5. Do "National Emission Standards for Hazardous Air Pollutants"  
(NESHAP) apply to this source? No

H. Do "Reasonably Available Control Technology" (RACT) requirements apply  
to this source? No

a. If yes, for what pollutants? \_\_\_\_\_

b. If yes, in addition to the information required in this form,  
any information requested in Rule 17-2.650 must be submitted.

Attach all supportive information related to any answer of "Yes". Attach any justifi-  
cation for any answer of "No" that might be considered questionable.

SECTION III: AIR POLLUTION SOURCES & CONTROL DEVICES (Other than Incinerators)

A. Raw Materials and Chemicals Used in your Process, if applicable:

Description	Contaminants		Utilization Rate - lbs/hr	Relate to Flow Diagram
	Type	% Wt		
----- SEE ATTACHMENT C -----				

B. Process Rate, if applicable: (See Section V, Item 1)

1. Total Process Input Rate (lbs/hr): not applicable
2. Product Weight (lbs/hr): not applicable

C. Airborne Contaminants Emitted: (Information in this table must be submitted for each emission point, use additional sheets as necessary)

Name of Contaminant	Emission <sup>1</sup>		Allowed <sup>2</sup> Emission Rate per Rule 17-2	Allowable <sup>3</sup> Emission lbs/hr	Potential <sup>4</sup> Emission		Relate to Flow Diagram
	Maximum lbs/hr	Actual T/yr			lbs/yr	T/yr	
----- SEE ATTACHMENT B -----							

<sup>1</sup>See Section V, Item 2.

<sup>2</sup>Reference applicable emission standards and units (e.g. Rule 17-2.600(5)(b)2. Table II, E. (1) - 0.1 pounds per million BTU heat input)

<sup>3</sup>Calculated from operating rate and applicable standard.

<sup>4</sup>Emission, if source operated without control (See Section V, Item 3).



J. Control Devices: (See Section V, Item 4)

Name and Type (Model & Serial No.)	Contaminant	Efficiency	Range of Particles Size Collected (in microns) (If applicable)	Basis for Efficiency (Section V Item 5)
----- SEE ATTACHMENT D -----				

E. Fuels

Type (Be Specific)	Consumption*		Maximum Heat Input (MMBTU/hr)
	avg/hr	max./hr	

\*Units: Natural Gas--MMCF/hr; Fuel Oils--gallons/hr; Coal, wood, refuse, other--lbs/hr.

Fuel Analysis:

Percent Sulfur: \_\_\_\_\_ Percent Ash: \_\_\_\_\_

Density: \_\_\_\_\_ lbs/gal Typical Percent Nitrogen: \_\_\_\_\_

Heat Capacity: \_\_\_\_\_ BTU/lb \_\_\_\_\_ BTU/gal

Other Fuel Contaminants (which may cause air pollution): \_\_\_\_\_

F. If applicable, indicate the percent of fuel used for space heating.

Annual Average \_\_\_\_\_ Maximum \_\_\_\_\_

G. Indicate liquid or solid wastes generated and method of disposal.

Waste water from air scrubbers is discharged to on-site waste water treatment plant;  
discharge to deepwell under UIC - Permit #UC05-126519.

- - - SEE ATTACHMENT D - - -

H. Emission Stack Geometry and Flow Characteristics (Provide data for each stack):

Stack Height: \_\_\_\_\_ ft. Stack Diameter: \_\_\_\_\_ ft.  
 Gas Flow Rate: \_\_\_\_\_ ACFM \_\_\_\_\_ DSCFM Gas Exit Temperature: \_\_\_\_\_ °F.  
 Water Vapor Content: \_\_\_\_\_ % Velocity: \_\_\_\_\_ FPS

**SECTION IV: INCINERATOR INFORMATION**

Type of Waste	Type 0 (Plastics)	Type I (Rubbish)	Type II (Refuse)	Type III (Garbage)	Type IV (Pathological)	Type V (Liq. & Gas By-prod.)	Type VI (Solid By-prod.)
Actual lb/hr Incinerated							
Uncontrolled (lbs/hr)							

Description of Waste \_\_\_\_\_  
 Total Weight Incinerated (lbs/hr) \_\_\_\_\_ Design Capacity (lbs/hr) \_\_\_\_\_  
 Approximate Number of Hours of Operation per day \_\_\_\_\_ day/wk \_\_\_\_\_ wks/yr. \_\_\_\_\_  
 Manufacturer \_\_\_\_\_  
 Date Constructed \_\_\_\_\_ Model No. \_\_\_\_\_

	Volume (ft) <sup>3</sup>	Heat Release (BTU/hr)	Fuel		Temperature (°F)
			Type	BTU/hr	
Primary Chamber					
Secondary Chamber					

Stack Height: \_\_\_\_\_ ft. Stack Diameter: \_\_\_\_\_ Stack Temp. \_\_\_\_\_  
 Gas Flow Rate: \_\_\_\_\_ ACFM \_\_\_\_\_ DSCFM\* Velocity: \_\_\_\_\_ FPS

\*If 50 or more tons per day design capacity, submit the emissions rate in grains per standard cubic foot dry gas corrected to 50% excess air.

Type of pollution control device: [ ] Cyclone [ ] Wet Scrubber [ ] Afterburner  
 [ ] Other (specify) \_\_\_\_\_

Brief description of operating characteristics of control devices: \_\_\_\_\_

Ultimate disposal of any effluent other than that emitted from the stack (scrubber water, ash, etc.):

NOTE: Items 2, 3, 4, 6, 7, 8, and 10 in Section V must be included where applicable.

#### SECTION V: SUPPLEMENTAL REQUIREMENTS

Please provide the following supplements where required for this application.

1. Total process input rate and product weight -- show derivation [Rule 17-2.100(127)]
2. To a construction application, attach basis of emission estimate (e.g., design calculations, design drawings, pertinent manufacturer's test data, etc.) and attach proposed methods (e.g., FR Part 60 Methods 1, 2, 3, 4, 5) to show proof of compliance with applicable standards. To an operation application, attach test results or methods used to show proof of compliance. Information provided when applying for an operation permit from a construction permit shall be indicative of the time at which the test was made.
3. Attach basis of potential discharge (e.g., emission factor, that is, AP42 test).
4. With construction permit application, include design details for all air pollution control systems (e.g., for baghouse include cloth to air ratio; for scrubber include cross-section sketch, design pressure drop, etc.)
5. With construction permit application, attach derivation of control device(s) efficiency. Include test or design data. Items 2, 3 and 5 should be consistent: actual emissions = potential (1-efficiency).
6. An 8 1/2" x 11" flow diagram which will, without revealing trade secrets, identify the individual operations and/or processes. Indicate where raw materials enter, where solid and liquid waste exit, where gaseous emissions and/or airborne particles are evolved and where finished products are obtained.
7. An 8 1/2" x 11" plot plan showing the location of the establishment, and points of airborne emissions, in relation to the surrounding area, residences and other permanent structures and roadways (Example: Copy of relevant portion of USGS topographic map).
8. An 8 1/2" x 11" plot plan of facility showing the location of manufacturing processes and outlets for airborne emissions. Relate all flows to the flow diagram.

- 9. The appropriate application fee in accordance with Rule 17-4.05. The check should be made payable to the Department of Environmental Regulation.
- 10. With an application for operation permit, attach a Certificate of Completion of Construction indicating that the source was constructed as shown in the construction permit.

**SECTION VI: BEST AVAILABLE CONTROL TECHNOLOGY**

A. Are standards of performance for new stationary sources pursuant to 40 C.F.R. Part 60 applicable to the source?

Yes  No

Contaminant	Rate or Concentration
_____	_____
_____	_____
_____	_____
_____	_____

B. Has EPA declared the best available control technology for this class of sources (if yes, attach copy)

Yes  No

Contaminant	Rate or Concentration
_____	_____
_____	_____
_____	_____
_____	_____

C. What emission levels do you propose as best available control technology?

Contaminant	Rate or Concentration
_____	_____
_____	_____
_____	_____
_____	_____

D. Describe the existing control and treatment technology (if any).

- |                           |                          |
|---------------------------|--------------------------|
| 1. Control Device/System: | 2. Operating Principles: |
| 3. Efficiency:*           | 4. Capital Costs:        |

Explain method of determining

- 5. Useful Life:
- 7. Energy:
- 9. Emissions:

- 6. Operating Costs:
- 8. Maintenance Cost:

Contaminant	Rate or Concentration

10. Stack Parameters

- a. Height: ft.      b. Diameter: ft.
- c. Flow Rate: ACFM      d. Temperature: °F.
- e. Velocity: FPS

E. Describe the control and treatment technology available (As many types as applicable, use additional pages if necessary).

1.

- a. Control Device: b. Operating Principles:
- c. Efficiency:<sup>1</sup> d. Capital Cost:
- e. Useful Life: f. Operating Cost:
- g. Energy:<sup>2</sup> h. Maintenance Cost:
- i. Availability of construction materials and process chemicals:
- j. Applicability to manufacturing processes:
- k. Ability to construct with control device, install in available space, and operate within proposed levels:

2.

- a. Control Device: b. Operating Principles:
- c. Efficiency:<sup>1</sup> d. Capital Cost:
- e. Useful Life: f. Operating Cost:
- g. Energy:<sup>2</sup> h. Maintenance Cost:
- i. Availability of construction materials and process chemicals:

<sup>1</sup>Explain method of determining efficiency.

<sup>2</sup>Energy to be reported in units of electrical power - KWH design rate.

- j. Applicability to manufacturing processes:
- k. Ability to construct with control device, install in available space, and operate within proposed levels:

3.

- a. Control Device:
- b. Operating Principles:
- c. Efficiency:<sup>1</sup>
- d. Capital Cost:
- e. Useful Life:
- f. Operating Cost:
- g. Energy:<sup>2</sup>
- h. Maintenance Cost:
- i. Availability of construction materials and process chemicals:
- j. Applicability to manufacturing processes:
- k. Ability to construct with control device, install in available space, and operate within proposed levels:

4.

- a. Control Device:
- b. Operating Principles:
- c. Efficiency:<sup>1</sup>
- d. Capital Costs:
- e. Useful Life:
- f. Operating Cost:
- g. Energy:<sup>2</sup>
- h. Maintenance Cost:
- i. Availability of construction materials and process chemicals:
- j. Applicability to manufacturing processes:
- k. Ability to construct with control device, install in available space, and operate within proposed levels:

F. Describe the control technology selected:

- 1. Control Device:
- 2. Efficiency:<sup>1</sup>
- 3. Capital Cost:
- 4. Useful Life:
- 5. Operating Cost:
- 6. Energy:<sup>2</sup>
- 7. Maintenance Cost:
- 8. Manufacturer:
- 9. Other locations where employed on similar processes:
  - a. (1) Company:
  - (2) Mailing Address:
  - (3) City:
  - (4) State:

Explain method of determining efficiency.  
 Energy to be reported in units of electrical power - KWH design rate.

(5) Environmental Manager:

(6) Telephone No.:

(7) Emissions:<sup>1</sup>

Contaminant	Rate or Concentration

(8) Process Rate:<sup>1</sup>

b. (1) Company:

(2) Mailing Address:

(3) City:

(4) State:

(5) Environmental Manager:

(6) Telephone No.:

(7) Emissions:<sup>1</sup>

Contaminant	Rate or Concentration

(8) Process Rate:<sup>1</sup>

10. Reason for selection and description of systems:

<sup>1</sup>Applicant must provide this information when available. Should this information not be available, applicant must state the reason(s) why.

### SECTION VII - PREVENTION OF SIGNIFICANT DETERIORATION

#### A. Company Monitored Data

1. \_\_\_\_\_ no. sites \_\_\_\_\_ TSP \_\_\_\_\_ ( ) SO<sub>2</sub>\* \_\_\_\_\_ Wind spd/di:

Period of Monitoring \_\_\_\_\_ / \_\_\_\_\_ / \_\_\_\_\_ to \_\_\_\_\_ / \_\_\_\_\_ / \_\_\_\_\_  
month day year month day year

Other data recorded \_\_\_\_\_

Attach all data or statistical summaries to this application.

Specify bubbler (B) or continuous (C).





*HARRIS SEMICONDUCTOR*

*AIR PERMIT - BUILDING 62*

*ATTACHMENT A*

*PROCESS DESCRIPTION*

## Attachment A

Building 62 is comprised of two units; building A and building B. Building B houses offices, a cafeteria, and conference rooms. The first floor of building A contains Semiconductor's research and development lab, and an analytical services laboratory, while a technical and prototype assembly lab reside on the second floor of the two-story building.

In the research and development laboratory, wafer fabrication processes (layering, patterning, doping and heating) are simulated. The goal of the lab is to develop new film processes for use in the on-site production of semiconductor wafers. These new operations may require new chemicals and equipment, as well as experimental wet chemistry techniques. The area resembles a small wafer fabrication area, with a variety of fab equipment being present. However, because this area is not used as a production area, the wet stations, coaters, developers, etchers, aligners, sputtering systems, and deposition furnaces, and associated burn boxes and pumps are present in low numbers.

The analytical services laboratory is responsible for physical and chemical characterization of microelectronic materials and products. A wide variety of analysis techniques are employed, including spectroscopy, separation methods, thermal analysis, and wet chemistry. The exhausted wet stations provide a safe location for analytical procedures involving wet chemistry.

For both of the above mentioned areas, gas cylinders that provide necessary process gases to the lab equipment are contained in exhausted gas cabinets located in the chases behind the appropriate area of use. Chemical storage cabinets hold virgin chemicals until they are ready for use.

In the technical lab on the second floor, electronic testing of new products (circuits that have not yet been released to the customer), and prototype assembly of circuits occurs. A relatively small number of equipment requiring exhaust exists in this area.

There are 19 wet stations located in the building. Approximately half of these stations house vats containing solvents. There are presently five stations containing heated vats; of these, four are acid stations, and one is a solvent station.

The exhaust for the building is divided between two scrubbers. Acid vapors are vented to scrubber number F62S01, while solvent exhaust streams are ducted to scrubber number F59S03. Both systems reside on the site grounds directly outside the south wall of building A (see site plan and scrubber location maps attached.)

*HARRIS SEMICONDUCTOR*

*AIR PERMIT - BUILDING 62*

*ATTACHMENT B*

*AIR EMISSIONS*

## ACID MONITORING--BUILDING 62

Monitoring was performed on the building 62 acid scrubber F62S01 in August of 1988. Samples were collected using modified EPA method 8 sampling train. The impinger medium consisted of a 0.1 N sodium hydroxide solution. The analytical methodology utilized to determine the ions of highest concentration is as follows:

Chloride ion--EPA Method 325.3

Fluoride ion--EPA Method 340.2

Nitrate, phosphite, and sulfate ions--ion chromatography

All results were in pounds per hour as "X", where "X" represents the acid compound present in highest concentration.

The test results revealed that the total accumulative monitored acid emissions for the building were 0.2497 tons/year expressed as hydrochloric, hydrofluoric, nitric, phosphoric and sulfuric acids. This figure is based on a hypothetical production schedule of 8760 hours a year. The monitoring was performed over an 8 hour time interval when the full production was occurring.

When a resulting acid concentration was expressed as a "less than 'y' " value, where 'y' represents the lowest detectable limit possible using the analytical methodology employed, acid emissions were taken to be equal to this 'y' limit value.

RESULTS OF ACID MONITORING--BUILDING 62  
 PERFORMED IN AUGUST OF 1988

Scrubber #	HCl	HF	Nitric Acid	Phosphoric Acid	Sulfuric Acid	TOTAL (TON/YR)
F62S01 outlet (lb/hr)	0.0160	0.0040	0.0200	0.0120	0.0050	
(ton/yr)	0.0701	0.0175	0.0876	0.0526	0.0219	0.2497

TOTAL ACID EMISSIONS INTO SCRUBBER OUTLET = 0.2497 TONS/YEAR

## SOLVENT MONITORING--BUILDING 62

Monitoring work was performed on the building 62 solvent scrubber system F62S02 during December of 1986 and August of 1987. Tests conducted include EPA methods 25A (flame ionization detection) and TO-1 (Tenax adsorption and GC/MS analysis.) The results of the testing is included in this application.

FID test results revealed that total accumulative monitored VOC emissions for the building were 0.83 tons/year expressed as propane. This figure is based on a hypothetical production schedule of 8760 hours a year. The following assumptions were made regarding monitoring work on this building:

-VOC values refer to all organic emissions including organic solvents.

-All data was corrected for 2 ppm background noise that is normally present in the ambient air.

-The F.I.D. accumulative emission figure is based on the maximum concentration of VOC's observed during the monitoring time frame.

EPA METHOD 25-A (F.I.D. ANALYSIS) BUILDING 62  
VOC EMISSIONS DURING PRODUCTION HOURS

TEST DATE	SCRUBBER #	VOC EMISSIONS (TON/YR)
12/08/86	F62S02	MIN
08/17/87	F62S02	0.83

NOTE: ABOVE BASED ON ACTUAL OPERATING HOURS.

TOTAL VOC EMISSIONS FROM BUILDING 62  
AS DETECTED BY EPA METHOD 25-A\*

SCRUB#	PRODUCTN SCHEDULE	PRODUCTN EMISSIONS (TON/YR)
F62S02	8760	0.83

\* Based on highest loading observed.

TOTAL PROJECTED VOC EMISSIONS FOR BLDG 62 = 0.83 TONS/YEAR

GC/MS:

AUGUST RESULTS-SCRUBBER NUMBER F62S02

ACETONE (LB/HR).....	2.86
TRICHLOROETHANE (LB/HR).....	0.04
METHYLENE CHLORIDE (LB/HR).....	---
TETRACHLOROMETHYLENE (LB/HR).....	trace
FREON-113 (LB/HR).....	1.19
CHLOROFORM (LB/HR).....	trace
BENZENE (LB/HR).....	trace
TRICHLOROETHYLENE (LB/HR).....	---
TOLUENE (LB/HR).....	trace
METHYL ISOBUTYL KETONE (LB/HR).....	---
ETHYL BENZENE (LB/HR).....	trace
XYLENES (LB/HR).....	trace



*HARRIS SEMICONDUCTOR*

*AIR PERMIT - BUILDING 62*

*ATTACHMENT C*

*RAW MATERIALS AND CHEMICALS*

HARRIS SEMICONDUCTOR  
BUILDING 62 CONSOLIDATED AIR PERMIT  
PROCESS CHEMICALS

ammonia  
ammonium persulfate  
acetic acid  
ammonium chloride  
ammonium fluoride  
ammonium hydroxide  
alkyl aryl sulfonic acid  
benzene  
benzidine dihydrochloride  
boron tribromide  
calcium carbonate  
calcium sulfate  
carbon tetrachloride  
ceric ammonium nitrate  
cupric sulfate  
ceric sulfate  
citric acid  
carbon disulfide  
chromium trioxide  
carbon tribromide  
chromic acid  
chlorinated hydrocarbons  
creosol  
cyanide  
DMAB  
dodecylbenzene sulfonic acid  
ethylene diamine tetraacetic acid  
ethylene dichloride  
ferric chloride  
ferric cyanide  
ferrous chloride  
formic acid  
ferric ammonium nitrate  
glacial acetic acid  
graphite  
glycerine  
gold chloride  
hydrochloric acid  
hydrofluoric acid  
hydrogen peroxide  
hydrocarbon propellant  
iodine  
isoparaffinic hydrocarbons  
lead oxide  
lead nitrate  
nickel

(CONT.)

nitric acid  
nickel sulfate  
nickelous chloride  
palladium  
pump oil  
piperidine  
perchloric acid  
potassium dichromate  
potassium ferricyanide  
potassium ferricyanide trihydrate  
potassium hydroxide  
potassium cyanide  
potassium iodide  
potassium permanganate  
potassium phosphate monobasic  
palladium chloride  
potassium nitrate  
P-toluene sulfonic acid  
potassium 2-chloro-4-nitrobenzoate  
phosphorus oxychloride  
phosphoric acid  
parrafinic grease  
sodium persulfate  
sodium hypophosphite  
silver chloride  
sodium hypochlorite  
sulfuric acid  
silanamine  
sodium thiosulfate  
sec-butanol  
silicone  
sodium chloride  
p-toluene sulfonic acid  
1,2,4 trichlorobenzene  
tetra methyl ammonium hydroxide  
zinc chloride

HARRIS SEMICONDUCTOR  
BUILDING 62 CONSOLIDATED AIR PERMIT  
PROCESS SOLVENTS

acetone  
aromatic phenol  
alkanolamine  
n-butyl acetate  
2-butoxy ethanol  
bis ether  
butanol  
bromotrifluoromethane  
cellosolve acetate  
chlorothene  
carbon tetrachloride  
chloroform  
dichlorodifluoromethane  
dimethyl formamide  
diethylene glycol monobutyl ether  
dibutyl phthalate  
1,2-dichloroethane  
2-ethyl-1,3-hexanediol  
2-ethoxyethyl acetate  
ethylene glycol monobutyl ether acetate  
ethylene glycol monomethyl ether  
ethanol  
ethacol  
ethylene diamine  
ethylene glycol  
ethanolamine  
ethyl acetate  
freon TF  
freon 12  
formaldehyde  
freon 14  
freon T-WD 602  
freon TA  
freon TMS  
glycol ether  
hexane  
hexamethyldisilazane  
isopropyl alcohol  
5-methyl-2-hexanone  
methyl ethyl ketone  
methyl T butyl ether  
monoethanolamine  
1-methoxy-2-propanol  
2-methoxy-1-propanol  
methanol  
n-methyl-2-pyrrolidone

(CONT.)

oxyphenol polyethoxylate  
propylene glycol methyl ether acetate  
2-pentanone  
petroleum ether  
sec-butyl alcohol  
tetraethyl orthosilicate  
trimethyl borate  
trimethyl phosphite  
toluene  
trichlorotrifluoroethane  
tetrafluoromethane  
tetramethyl ammonium hydroxide  
trichlorotrifluoroethane  
1,1,2-trichloro-1,2,2 trifluoroethane  
1,1,1 trichloroethane  
1,2,4 trichlorobenzene  
1,1,1 trimethyl-n-trimethyl ether  
trichloroethylene  
xylene

HARRIS SEMICONDUCTOR  
BUILDING 62 CONSOLIDATED AIR PERMIT  
PROCESS GASSES

arsine  
carbon dioxide  
nitrogen  
potassium hydroxide  
propane  
argon  
nitrous oxide  
oxygen  
silane  
helium  
acetylene  
hydrogen  
phosphine  
ammonia  
dichlorosilane  
chlorine  
freon 115  
freon 116  
freon 14  
germanium tetrafluoride  
halocarbon 13-B1  
halocarbon 23  
sulfur hexafluoride  
carbon tetrafluoride  
trifluoromethane  
nitrous oxide  
nitrogen trifluoride  
phosphorous pentafluoride  
phosphorus trifluoride  
tungsten hexafluoride

*HARRIS SEMICONDUCTOR*

*AIR PERMIT - BUILDING 62*

*ATTACHMENT D*

*CONTROL EQUIPMENT*

HARRIS SEMICONDUCTOR

-- AIR PERMIT INFORMATION

CURRENT PERMIT

BUILDING: 62  
PERMIT NUMBER: AO 05-121927  
PERMIT TYPE : OPERATING

DATE ISSUED : 09/18/86  
RENEWAL DATE: 07/16/91  
DATE EXPIRES: 09/14/91

AREA SERVED:

PROCESS DESCRIPTION: ACID VAPOR SCRUBBER

PERMIT LIMITS

VOL. RATE (SCFM): 24,000  
ACID MIST (LB/HR): 0.0537  
SOLVENTS (LB/HR): --  
VOCS (LB/HR): --  
OPER. (HRS/YEAR): 2112

SPECIFIC CONDITIONS

ANNUAL OPERATING REPORT : 03/01  
NOTIFICATION OF VE TEST : 10/26  
ANNUAL VIS EMISSION TEST: 11/10

EQUIPMENT INFORMATION

MANUFACTURER : BEVERLY PACIFIC      MODEL NUMBER : PS-24HT  
LOCATION : B62 GROUND SOUTHWEST CORNER  
HARRIS ID NUMBER : F62S01      STACK HEIGHT (FT): 35  
VOLUME FLOW RATE (CFM): 24,000      STACK DIAMETER (IN): 28  
RECIRCULATION RATE (GPM): 105      STACK VELOCITY (FPM):  
MAKEUP WATER RATE (GPM): 10.0      DUCT MATERIAL :

PERMIT HISTORY

PERMIT NUMBER: AC 05-54994  
DATE EXPIRED : 06/00/84

PERMIT NUMBER: AC 05-104514  
DATE EXPIRED : 06/30/86

PERMIT NUMBER:  
DATE EXPIRED :



SCRUBBER INFORMATION

HARRIS ID # : F62S01  
MANUFACTURER : BEVERLY PACIFIC MODEL NUMBER : PS-24HT  
SERIAL NUMBER: F-600 MATERIAL : FIBERGLASS  
DESCRIPTION : HORIZONTAL CROSS FLOW, NON-CLOGGING PVC SPRAY NOZZLES,  
POLYPROPYLENE PACKING, PVC MIST ELIMINATOR, DWG. F-600-3

DESIGN DATA

VOLUME FLOW RATE (CFM): 24,000 PRESSURE DROP (IN):  
RECIRCULATION RATE (GPM): 105 MAKE UP RATE (GPM): 10

ACTUAL DATA

VOLUME FLOW RATE (CFM): PRESSURE DROP (IN): N/E DATE: 06/03/87  
RECIRCULATION RATE (GPM): 58 MAKE UP RATE (GPM): 7.5 DATE: "

RECIRCULATION PUMP INFORMATION

MANUFACTURER : FILTER PUMP IND MODEL NUMBER : 35G 205-672  
SERIAL NUMBER: F 1081 HP : 2 RPM : 3450  
BRKR LOCATION: NEXT TO UNIT FED FROM MCC : DEM

FAN INFORMATION

HARRIS ID # :  
MANUFACTURER : BEVERLY PACIFIC MODEL NUMBER: CB-40  
SERIAL NUMBER: F-600 MATERIAL : FIBERGLASS  
DESCRIPTION : CENTRIFUGAL TYPE, CLASS II, BACKWARD CURVED BLADES,  
DWG. F-600-3

DESIGN DATA

VOLUME FLOW RATE (CFM): 21,000 STATIC PRESS (IN): 5.0

ACTUAL DATA

VOLUME FLOW RATE (CFM): SPEED (RPM): 936 DATE: SUBMITTAL  
STATIC PRESS (IN): DATE:

FAN MOTOR INFORMATION

MANUFACTURER : MODEL NUMBER :  
SERIAL NUMBER: HP : 40 RPM :  
BRKR LOCATION: FS62A2 FED FROM MCC : DEM #11

Attachment :

HARRIS SEMICONDUCTOR

--

AIR PERMIT INFORMATION

CURRENT PERMIT

BUILDING: 62  
PERMIT NUMBER: AC 05-104513  
PERMIT TYPE : CONSTRUCTION

DATE ISSUED : 01/15/86  
RENEWAL DATE: 04/01/86  
DATE EXPIRES: 06/30/86

AREA SERVED:  
PROCESS DESCRIPTION: VOC/SOLVENT SCRUBBER

PERMIT LIMITS

VOL. RATE (SCFM): 12,000  
ACID MIST (LB/HR): --  
SOLVENTS (LB/HR): 0.0537  
VOCS (LB/HR): --  
OPER. (HRS/YEAR): 2112

SPECIFIC CONDITIONS

ANNUAL OPERATING REPORT :  
NOTIFICATION OF VE TEST :  
ANNUAL VIS EMISSION TEST:

EQUIPMENT INFORMATION

MANUFACTURER : BEVERLY PACIFIC MODEL NUMBER : PS-12VT  
LOCATION : B62 GROUND SOUTHWEST CORNER  
HARRIS ID NUMBER : F62S02 STACK HEIGHT (FT): 35  
VOLUME FLOW RATE (CFM): 12,000 STACK DIAMETER (IN): 31  
RECIRCULATION RATE (GPM): 45 STACK VELOCITY (FPM):  
MAKEUP WATER RATE (GPM): 4.0 DUCT MATERIAL :

PERMIT HISTORY

PERMIT NUMBER: AC 05-54992  
DATE EXPIRED : 06/00/84

PERMIT NUMBER: AC 05-104513  
DATE EXPIRED : 06/30/86

PERMIT NUMBER:  
DATE EXPIRED :

SCRUBBER INFORMATION

HARRIS ID # : F62S02  
MANUFACTURER : BEVERLY PACIFIC MODEL NUMBER : PS-12VT  
SERIAL NUMBER: F-600 MATERIAL : FIBERGLASS  
DESCRIPTION : VERTICAL COUNTER-CURRENT, NON-CLOGGING PVC SPRAY NOZZLES,  
POLYPROPYLENE PACKING, PVC MIST ELIMINATOR, DWG. F-600-4

DESIGN DATA

VOLUME FLOW RATE (CFM): 12,000 PRESSURE DROP (IN):  
RECIRCULATION RATE (GPM): 45 MAKE UP RATE (GPM): 4.0

ACTUAL DATA

VOLUME FLOW RATE (CFM): 10,235 PRESSURE DROP (IN): 0.8 DATE: 12/08/86  
RECIRCULATION RATE (GPM): 40 MAKE UP RATE (GPM): 3 DATE: 06/03/87

RECIRCULATION PUMP INFORMATION

MANUFACTURER : FILTER PUMP MODEL NUMBER : 35G 205X504  
SERIAL NUMBER: P18904 HP : 1.5 RPM : 3450  
BRKR LOCATION: NEXT TO UNIT FED FROM MCC : DEM

FAN INFORMATION

HARRIS ID # :  
MANUFACTURER : BEVERLY PACIFIC MODEL NUMBER: CB-27  
SERIAL NUMBER: F-600 MATERIAL : FIBERGLASS  
DESCRIPTION : CENTRIFUGAL TYPE, CLASS II, BACKWARD CURVED BLADES  
DWG. F-600-4

DESIGN DATA

VOLUME FLOW RATE (CFM): 8,500 STATIC PRESS (IN): 6.0

ACTUAL DATA

VOLUME FLOW RATE (CFM): 10,235 SPEED (RPM): 1483 DATE: SUBMITTAL  
STATIC PRESS (IN): DATE: 12/08/86

FAN MOTOR INFORMATION

MANUFACTURER : MODEL NUMBER :  
SERIAL NUMBER: HP : 20 RPM :  
BRKR LOCATION: FS62A1 FED FROM MCC : DEM #3

Attachment :

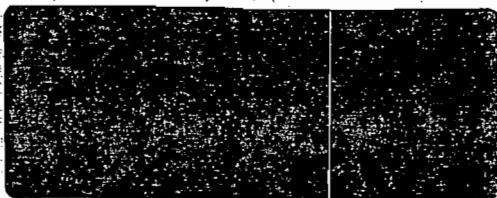

**BEVERLY PACIFIC CORPORATION**

1000 WEST 10TH AVENUE, DENVER, COLORADO 80202

SCRUBBERS

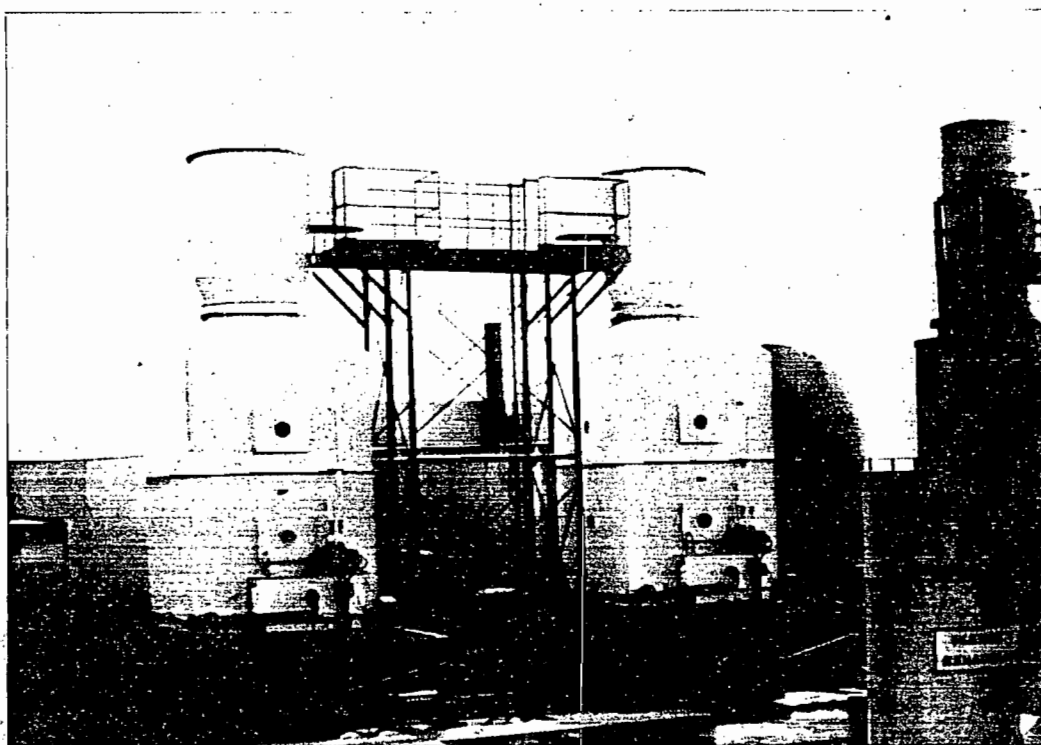

FIBERGLASS REINFORCED PLASTIC

## **COMPUTERIZED PACKING MEDIA SELECTION**

The most common mistake made by scrubber manufacturers today is the use of only one type of packing media for all types of contaminant removal. Beverly Pacific Corporation scrubbers are designed with a computer program assist to determine the most beneficial packing media to achieve high removal efficiency coupled with low pressure drop providing the user with the ultimate in lower operating costs consistent with the contaminant removal requirements.

## **SCRUBBER CONFIGURATIONS**

Beverly Pacific Corporation manufactures scrubbers of both crossflow and counter-current configurations.

The CROSSFLOW design is of low profile, rectangular shape wherein the contaminated air stream moves horizontally through the packing media and is scrubbed by the liquid flowing downward through the packing. This configuration is ideal for roof-top mounting and is available in ten (10) standard sizes with or without integral centrifugal fans.

The COUNTER-CURRENT design is offered in two (2) configurations, round or rectangular. While the round tower unit is the most economical in initial cost, the rectangular tower unit permits larger CFM volume using the same amount of floor space. In the counter-current design, the contaminated airstream flows up through the packing media and is scrubbed by the liquid flowing downward. The round and rectangular tower units are each offered in ten (10) sizes and are available with or without integral inline or centrifugal fans.

## **SCRUBBER MAKE-UP WATER CONSUMPTION**

Beverly Pacific's scrubber design is based on a scrubbing liquid recirculation rate of 5 GPM per 1000 CFM of contaminated air. Of that 5 GPM, losses due to absorption and/or evaporation range from 0.2 GPM to 0.6 GPM, depending on inlet gas temperature and gas stream dust load.

## **ENTRAINMENT SEPARATION**

The unique design of Beverly Pacific's mist eliminator section provides up to 99+% moisture particle entrapment at a pressure drop of approximately 0.5" W.G.

## **CONSTRUCTION**

The structural housings are fabricated of Fiberglass Reinforced Plastic (FRP) materials which provide structural strength, are corrosion-resistant and light in weight. Resin selection depends on the corrosive element involved. Resins can also be of fire-retardant grade if required. Our construction technique employs the use of female molds resulting in an extremely smooth, attractive, gelcoated exterior surface (note the upper right photo on the facing page). Beverly Pacific Corporation's construction methods meet or exceed the requirements of NBS-PS 15-69 for custom contact-molded reinforced polyester chemical resistant process equipment.

## **OPTIONAL EQUIPMENT, FITTINGS AND ACCESSORIES**

FITTINGS, such as drain, overflow, make-up water, access doors, etc. can usually be located to facilitate installation and maintenance.

RECIRCULATION RESERVOIR(S) are normally an integral part of the scrubber but, if required, can be furnished for remote installation.

RECIRCULATION PUMP(S) can be located within the built-in reservoir, but can also be installed in remote reservoir units.

SPECIAL RESERVOIR(S) can be furnished in applications where it is necessary to remove non-soluble particulate accumulation to prevent pump damage and minimize maintenance.

pH CONTROL SENSING/METERING equipment can be provided where contaminate absorption requires the addition of acid or caustic to the recirculated scrubbing liquid.

**PACKED SCRUBBER DIMENSIONAL CHART**  
**MODEL NUMBERS**  
**BEST AVAILABLE COPY**  
**DIMENSIONS IN INCHES**

	PS-2	PS-4	PS-6	PS-8	PS-12	PS-16	PS-24	PS-30	PS-40	PS-50
A	78	82	84	94	101	108	112	114	118	118
B	24	36	42	48	60	72	84	96	108	120
C	28	40	48	58	72	84	96	108	120	136
D	22	34	40	46	58	70	80	92	104	116
E	6	8	10	11	12	16	18	20	24	24
F	46	58	66	76	90	102	114	126	138	154
G	42	54	60	66	78	90	102	114	126	138
H	13 <sup>3</sup> / <sub>8</sub>	16 <sup>3</sup> / <sub>8</sub>	22 <sup>1</sup> / <sub>2</sub>	26 <sup>1</sup> / <sub>2</sub>	29 <sup>1</sup> / <sub>2</sub>	35 <sup>1</sup> / <sub>4</sub>	39	47 <sup>1</sup> / <sub>4</sub>	52 <sup>3</sup> / <sub>8</sub>	63 <sup>3</sup> / <sub>8</sub>
I	10 <sup>3</sup> / <sub>8</sub>	12 <sup>3</sup> / <sub>8</sub>	17	20 <sup>1</sup> / <sub>2</sub>	22 <sup>3</sup> / <sub>4</sub>	27	30	37 <sup>1</sup> / <sub>2</sub>	40 <sup>3</sup> / <sub>4</sub>	49 <sup>3</sup> / <sub>4</sub>
J	18	22	28	34	38	45	50	62	66	80
K	6	8	10	10	12	16	19	20	24	24
L	84	87	89	104	112	118	122	124	128	128
M	64	64	70	77	89	102	102	102	114	114
N	35	49	55	62	76	88	108	116	128	142
O	38	52	58	65	79	91	108	119	131	145
P	14	16	22	26	30	36	42	50	54	66
Q	45	50	61	64	68	72	78	86	93	103
R	35	44	55	65	75	85	94	108	120	141
S	46	52	59	69	72	79	82	97	100	110
T	36	48	54	60	72	84	96	108	120	132
WHEEL DIA.	12 <sup>1</sup> / <sub>2</sub>	15	20	24 <sup>1</sup> / <sub>2</sub>	27	33	36 <sup>1</sup> / <sub>2</sub>	44 <sup>1</sup> / <sub>2</sub>	49	60
CFM x 1000	1-2	2-4	4-6	6-8	8-12	12-18	18-24	24-30	30-40	40-50
RECIRC. GPM	7	15	25	35	45	75	105	135	175	225
MAKE-UP GPM	0.7	1.5	2.0	3.0	4.0	7.0	10.0	13.0	17.0	22.0
HT OP. WT.	388	745	1110	1570	2690	4085	5670	7595	11790	16040
HT SHIP WT.	220	385	550	770	1210	1925	2750	3795	5390	7040
VT OP. WT.	318	660	1060	1500	2630	3910	5470	7400	11650	15800
VT SHIP WT.	150	300	500	700	1150	1750	2550	3600	5250	6800

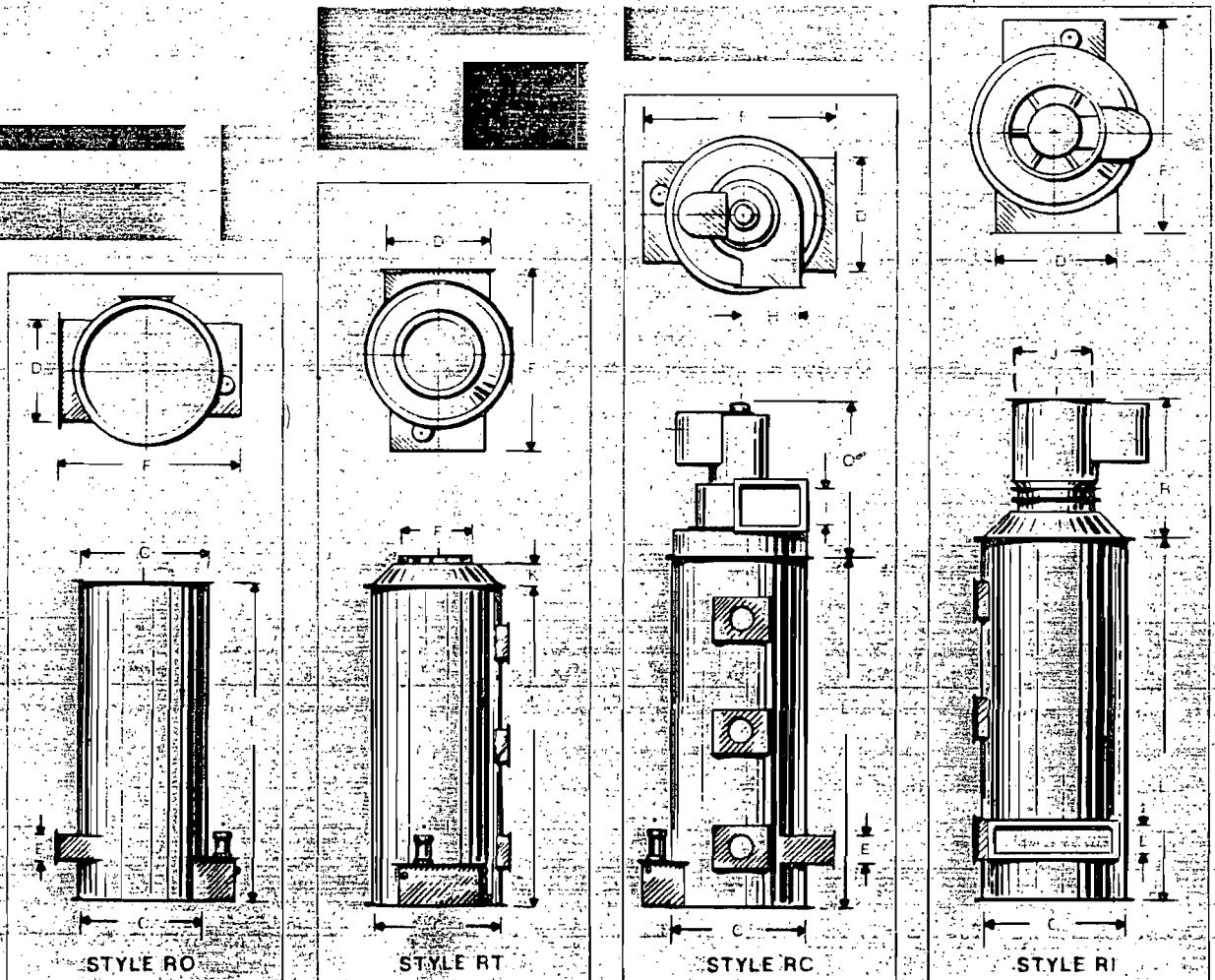

BEST AVAILABLE COPY

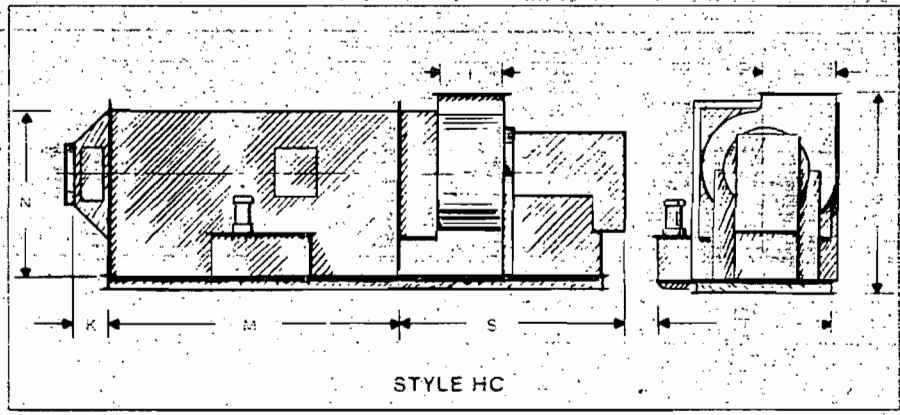
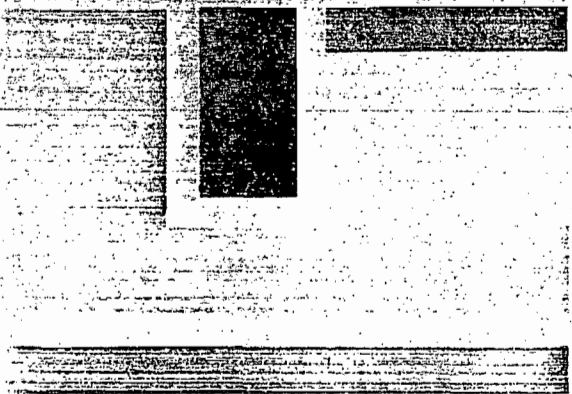
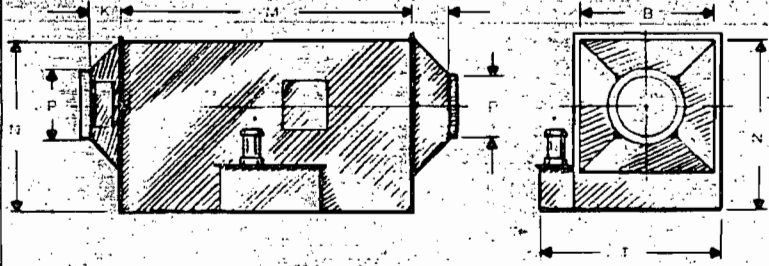

May require one or more pumps.

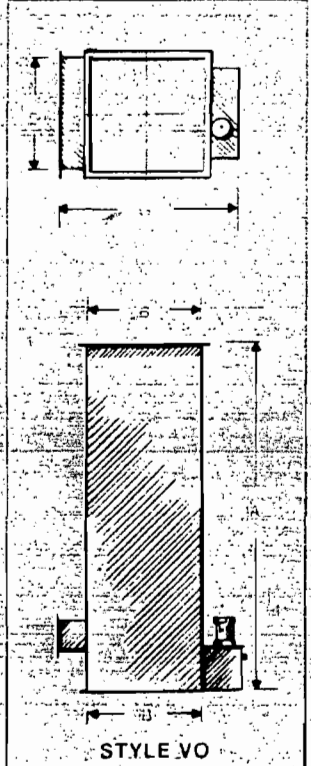
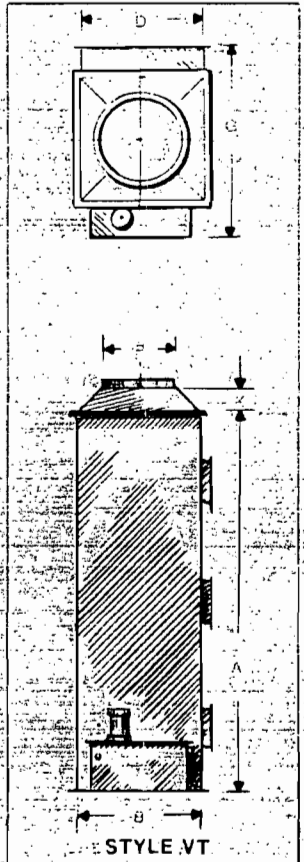
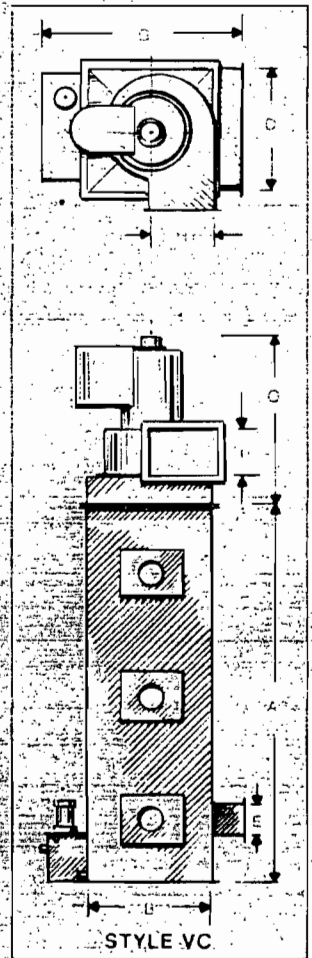
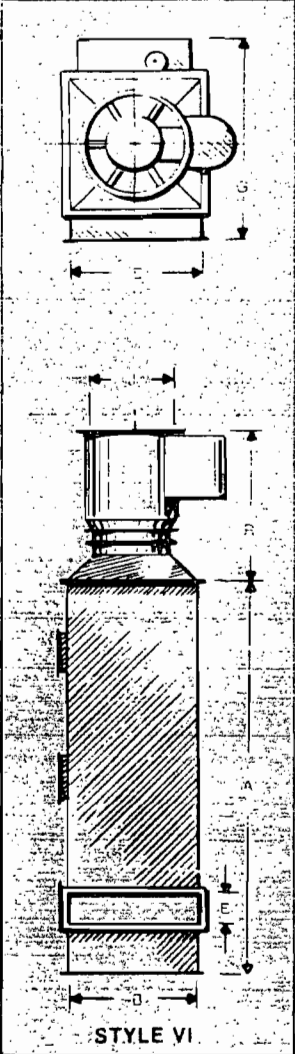



BEST AVAILABLE COPY

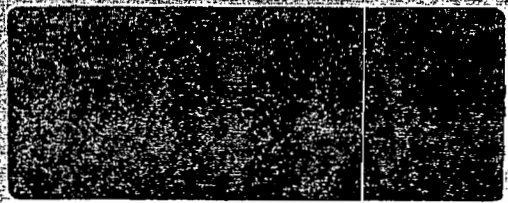

BEST AVAILABLE COPY



**BEVERLY PACIFIC CORPORATION**

*Industrial Systems Division*

# EXHAUST FANS

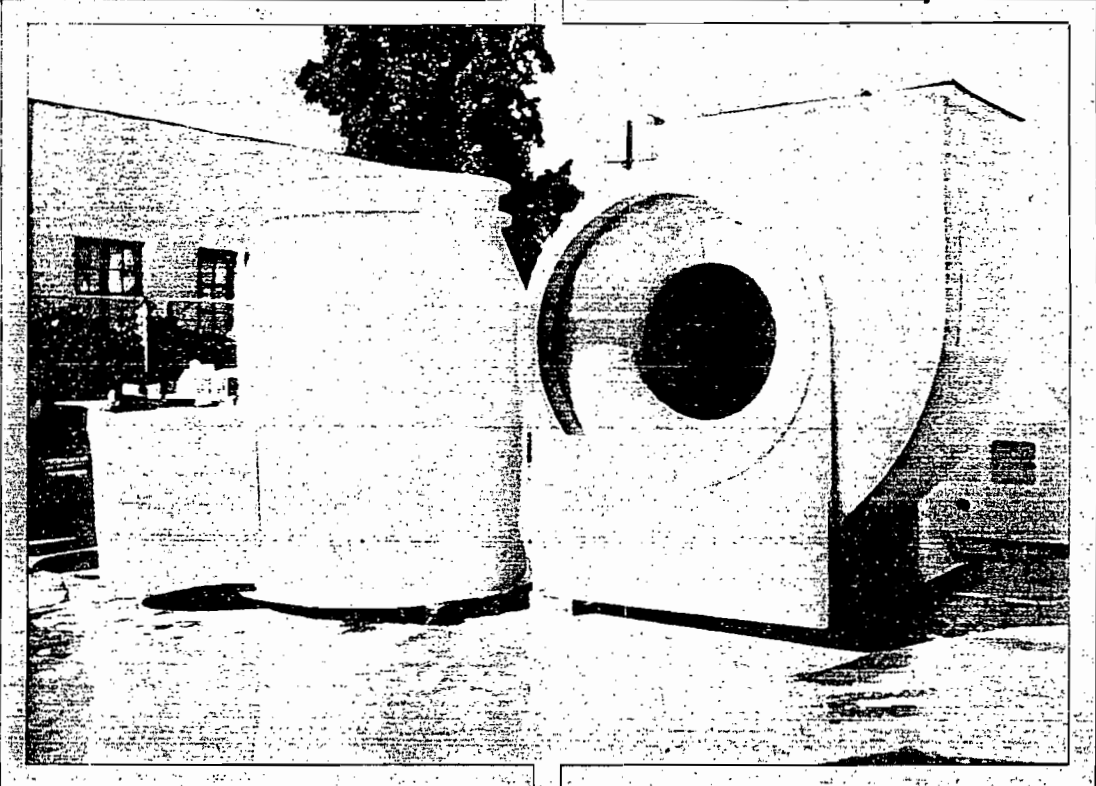

**FIBERGLASS REINFORCED PLASTIC**



## BEST AVAILABLE COPY

### EXHAUST FAN INTRODUCTION

Beverly Pacific's complete line of centrifugal and inline exhaust fans have proven their reliability with years of successful, continuous corrosive service throughout the nation and around the world.

Our solid "FRP" construction defies corrosion and each is designed to provide smooth, quiet and maintenance-free operation. . . this superior combination permits peak performance with the lowest possible power consumption.

A wide selection of standard models, types and sizes are available to meet your specific requirements.

### FAN WHEEL SUPERIORITY

The Beverly Pacific fan wheels are fabricated of corrosion-resistant Fiberglass Reinforced Plastic (FRP) materials. The fan wheel design is that of a "backward curve blade," Class II construction, and are available in standard sizes of 12 1/4" through 66" diameters.

All of Beverly Pacific's fan wheels are both statically and dynamically balanced and run on a test stand prior to final assembly to insure continuous, vibration-free performance.

Every surface in contact with the air stream is corrosion resistant. The steel hub (providing the positive-lock connection to the drive shaft) is totally encapsulated in the wheel laminate and even the weight added during the wheel balancing process is corrosion resistant, Fiberglass Reinforced Plastic materials.

Should your particular requirement involve moving a volume of only a few hundred CFM at 1/4" S.P. or over 80,000 CFM at 6" S.P., Beverly Pacific has a proven standard size to meet your requirement.

### EXHAUST FANS STANDARD AND OPTIONAL EQUIPMENT

Standard Equipment: Beverly Pacific's centrifugal fans are equipped with a scroll bottom drain and flanged discharge outlet, and are furnished with a purchaser's choice of twelve (12) discharge outlet directions and a choice of right or left fan wheel rotation. Both of our fan styles, centrifugal and inline, are equipped with an OSHA approved belt guard and powered by 230-460/30/60 Hz motors. . . totally enclosed, fan-cooled, (TEFC) up to 20 horsepower, and Multi-guard motors are furnished when horsepower requirements are 25 or larger. Also, as standard equipment, Beverly Pacific furnishes the following list of first-line, top quality drive components which were selected based on motor horsepower, RPM, tip speed and weight of fan wheel, with a safety factor of 1.3 times the motor horsepower:

- a. BEARINGS — Beverly Pacific furnishes Dodge Type K pillow blocks on the inline model. These Dodge bearings have Timken tapered roller bearings, are fully self-aligning and designed to meet the stringent demands of power transmission. Based on radial and thrust load computations, bearing life expectancy is in excess of 100,000 hours.
- b. SHEAVES — Beverly Pacific Corporation furnishes Dodge sheaves, which are cast from the finest quality gray iron and machined to rigid quality control specifications. Groove design and spacing conforms to ASA, MPTA and RMA standards. These sheaves are equipped with Taper-Lock bushings, a superior mounting well recognized and widely used in industry.
- c. V-BELTS — Beverly Pacific furnishes Dodge Scaled-Life Belts, Type A, B and C which have a longer wearing protective cover, crowned top, concave sidewall, exceptional stability and an improved cord section which prevents failures caused by cord separation.
- d. WHEEL BACKING PLATES — Beverly Pacific uses Rex taper-lock, single-duty, Type B, steel sprocket, in the backing plate of all FRP fan wheels. This steel sprocket is completely embedded and encased with FRP materials to prevent corrosion attack.
- e. DRIVE SHAFTS — Beverly Pacific uses ground and polished, 1045 TGP shafting rounds, as produced by Inland Steel. This medium carbon steel is used because of its greater strength and hardness. The mechanical properties, based on 3/4" — 1 1/4" diameter round bars of 1045, include a tensile strength of 98,000 PSI, yield strength of 59,000 PSI and a Brinell Hardness of 212.

BEVERLY PACIFIC CORPORATION  
CENTRIFUGAL FAN CHARACTERISTIC CURVE

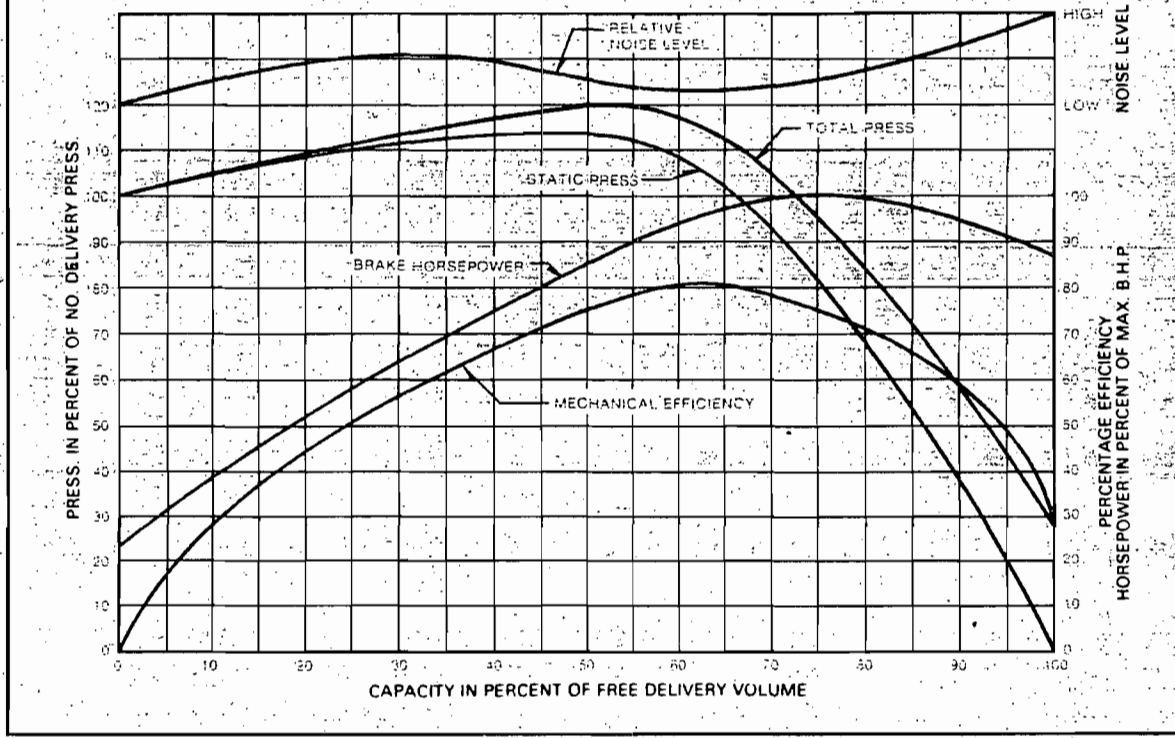

BEVERLY PACIFIC CORPORATION  
INLINE FAN CHARACTERISTIC CURVE

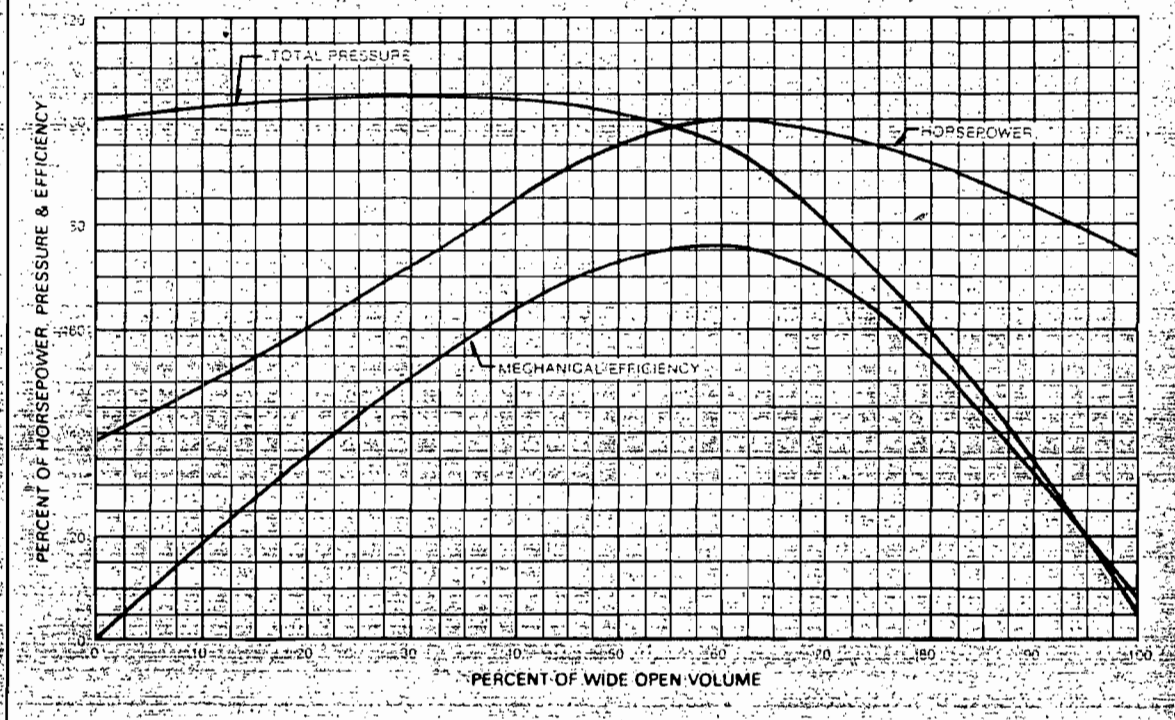



BEST AVAILABLE COPY

CENTRIFUGAL INDUSTRIAL EXHAUST FANS

	CB-12	CB-13	CB-15	CB-16	CB-18	CB-20	CB-22	CB-24	CB-27	CB-30	CB-33	CB-36
<b>MID-RANGE CFM RECOMMENDED</b>	2,150	2,625	3,200	3,900	4,750	5,800	7,075	8,650	10,550	12,875	15,700	19,150
<b>FAN WHEEL DIAMETER</b>	12 1/4	13 1/2	15	16 1/2	18 1/4	20	22 1/4	24 1/2	27	30	33	36 1/2
<b>A</b>	13 1/2	14 1/2	16 1/2	18 1/4	20	22	24 1/2	26	29 1/4	32 1/4	36	40
<b>B</b>	10 3/4	11 3/4	12 7/8	14 3/8	15	17	18 3/4	20 1/2	22 1/4	25	27	30
<b>C</b>	13 3/8	14 7/8	16 3/8	18 3/8	20	22 1/2	24	26 1/4	29 1/2	32	35 1/4	39
<b>D</b>	34 1/8	35 1/8	40 1/16	42 1/16	45	47 1/4	54	57 1/4	61 1/2	64 1/2	68 1/2	69 1/2
<b>E</b>	22 1/4	22 1/2	27 1/8	29 1/4	32 1/2	36 1/2	39 1/4	43 1/4	49	53	58 1/2	65 1/2
<b>F</b>	15	16	18	19	20	23	26	28	30	33	36	51 1/2
<b>G</b>	11	11 1/2	12 1/2	14	15 1/2	17 1/4	19	21 1/2	23	25 1/2	28 1/2	30 1/2
<b>H</b>	13 3/4	14 3/4	15 3/4	17 3/8	18	21	22 3/4	24 1/2	26 3/4	29	31	34
<b>I</b>	16	16	18 1/4	18 3/4	20	20 1/2	23	23	25	26	26	26
<b>J</b>	3	3	4	4	4	4	6	6	6	6	6	6
<b>K</b>	9 1/4	10 1/4	11 1/4	12 1/2	13 1/2	15	16	18	20 1/2	22	24	27
<b>L</b>	8 1/4	10 1/4	11 1/4	12 1/2	13 1/2	15	16	18	20 1/2	22	24	27
<b>M</b>	3 1/2	3 1/4	4 1/4	4 1/2	5	5 1/4	6 1/4	6 1/2	7 1/4	8 1/4	9 1/2	10 1/4
<b>DRIVE SHAFT DIAMETER</b>	1	1	1 1/16	1 1/16	1 1/16	1 1/16	1 1/16	1 1/16	1 1/16	1 1/16	1 1/16	2 1/16
<b>SHIPPING WEIGHT POUNDS</b>	170	205	230	400	550	600	650	720	850	1,000	1,380	1,610

DESIGNATION OF DIRECTION OF ROTATION AND DISCHARGE

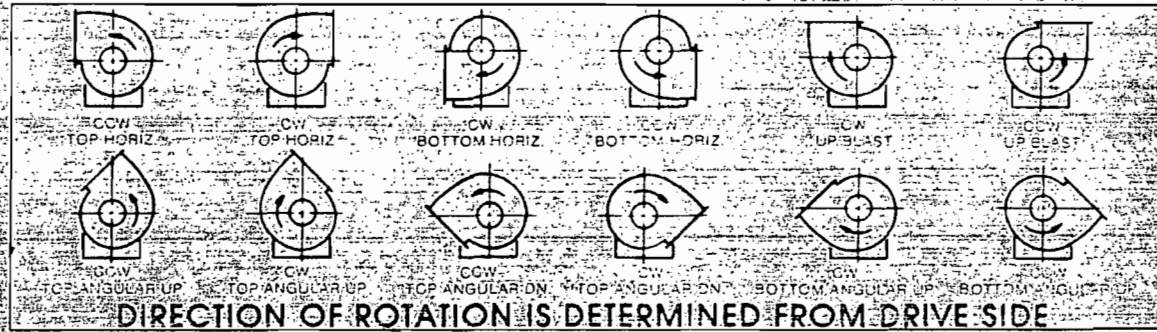

INLINE EXHAUST FANS

	IB-12	IB-15	IB-18	IB-20	IB-22	IB-24	IB-27	IB-30	IB-33	IB-36	IB-40	IB-44
<b>MID-RANGE CFM RECOMMENDED</b>	2,550	3,842	4,648	5,614	6,948	8,424	10,242	12,644	15,300	18,718	22,761	27,822
<b>FAN WHEEL DIAMETER</b>	12 1/4	15 1/4	18 1/4	20	22 1/4	24 1/2	27	30	33	36 1/2	40 1/2	44 1/2
<b>P</b>	21"	28"	32 1/2"	36 1/2"	40"	47"	53"	55"	58"	63 1/4"	70"	78"
<b>Q</b>	14"	16"	20"	22"	24"	26"	30"	32"	36"	42"	46"	50"
<b>R</b>	18"	22"	26"	28"	32"	34"	38"	42"	45"	50"	56"	62"
<b>S</b>	2"	2"	2"	2"	2"	3"	3"	3"	3"	3"	3"	3"
<b>T</b>	23"	28"	31 1/2"	32"	34"	35"	37"	39"	40 1/2"	45"	52"	63"
<b>U</b>	2"	2"	2"	2"	2"	3"	3"	3"	3"	3"	3"	3"
<b>DRIVE SHAFT DIAMETER</b>	1	1 1/16	1 1/16	1 1/16	1 1/16	1 1/16	1 1/16	1 1/16	1 1/16	1 1/16	2 1/16	2 1/16
<b>SHIPPING WEIGHT POUNDS</b>	80	130	280	320	350	380	450	525	730	850	1,110	1,250



**DIMENSIONAL CHART**

	CB-44	CB-49	CB-54	CB-60	CB-66	
375	28,525	34,775	42,450	51,775	63,175	<b>MID-RANGE CFM RECOMMENDED</b>
	44½	49	54¼	60	66	<b>FAN WHEEL DIAMETER</b>
	49	54	60	66	72	A
	37½	40¾	44¾	49¾	54¾	B
	47¼	52¾	57¾	63¾	70¼	C
	84¼	88	93	97¾	104¾	D
	79½	88¼	97	108	119	E
	49¼	49	54	59	64	F
	37½	41	46	50½	55	G
	43½	46¾	50¾	53¾	60¾	H
	29½	29½	31¼	33	33	I
	8	8	8	8	8	J
	26¼	30	34	37	40	K
	26¼	30	34	37	40	L
	12¼	14½	15½	17¾	19½	M
	2½	2½	2½	2½	2½	<b>DRIVE SHAFT DIAMETER</b>
2,500	2,300	2,650	3,110	3,525	4,000	<b>SHIPPING WEIGHT POUNDS</b>

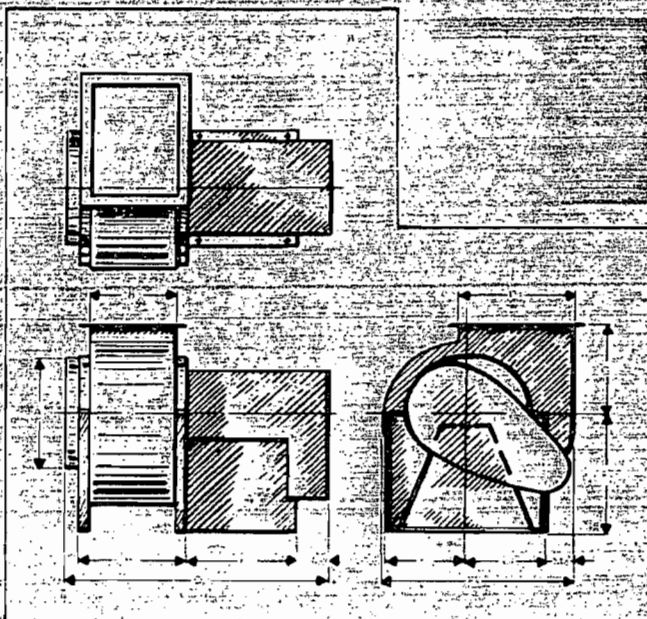

**STANDARD CLASSIFICATIONS FOR SPARK RESISTANT CONSTRUCTION**

TYPE	CONSTRUCTION
A	All parts of the fan in contact with the air or gas being handled shall be made of non-ferrous material.
B	The fan shall have an entirely non-ferrous wheel and non-ferrous ring about the opening through which the shaft passes.
C	The fan shall be so constructed that a shift of the wheel or shaft will not permit two ferrous parts of the fan to rub or strike.

**DIMENSIONAL CHART**

	IB-49	IB-54	IB-60	IB-66	
33,733	41,349	50,579	61,201		<b>MID-RANGE CFM RECOMMENDED</b>
49	54¼	60	66		<b>FAN WHEEL DIAMETER</b>
34"	83"	104"	116"		P
34"	60"	66"	72"		Q
36"	72"	80"	88"		R
37"	3"	3"	3"		S
37"	68"	72"	76"		Y
37"	3"	3"	3"		U
2½	2½	2½	2½		<b>DRIVE SHAFT DIAMETER</b>
420	1,650	1,800	2,100		<b>SHIPPING WEIGHT POUNDS</b>

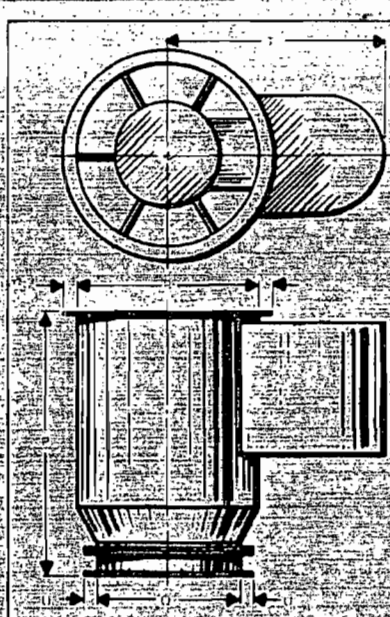



CENTRIFUGAL CAPACITY RATING TABLES

DATA ON WHITE BACKGROUND APPLIES TO CLASS I WHEELS

DATA ON BLUE BACKGROUND APPLIES TO CLASS II WHEELS

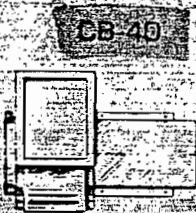

Table for CB-40 showing Volume (GPM) and Capacity (GPM) for various RPM values (1120, 1025, 925, 825, 725, 625, 525, 425, 325, 225, 125) and Inlet Diameter (40" DIA).

Table for CB-40 showing Capacity (GPM) for various RPM values (1120, 1025, 925, 825, 725, 625, 525, 425, 325, 225, 125) and Inlet Diameter (40" DIA).



Table for CB-40 showing Capacity (GPM) for various RPM values (1120, 1025, 925, 825, 725, 625, 525, 425, 325, 225, 125) and Inlet Diameter (40" DIA).

Table for CB-40 showing Capacity (GPM) for various RPM values (1120, 1025, 925, 825, 725, 625, 525, 425, 325, 225, 125) and Inlet Diameter (40" DIA).

WHEEL 40" DIA  
INLET 44" DIA  
CLASS MAX RPM  
880  
1120

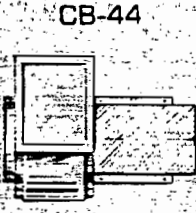

Table for CB-44 showing Volume (GPM) and Capacity (GPM) for various RPM values (1015, 925, 825, 725, 625, 525, 425, 325, 225, 125) and Inlet Diameter (44" DIA).

Table for CB-44 showing Capacity (GPM) for various RPM values (1015, 925, 825, 725, 625, 525, 425, 325, 225, 125) and Inlet Diameter (44" DIA).

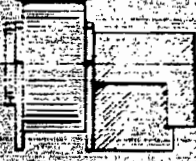

Table for CB-44 showing Capacity (GPM) for various RPM values (1015, 925, 825, 725, 625, 525, 425, 325, 225, 125) and Inlet Diameter (44" DIA).

Table for CB-44 showing Capacity (GPM) for various RPM values (1015, 925, 825, 725, 625, 525, 425, 325, 225, 125) and Inlet Diameter (44" DIA).

WHEEL 44" DIA  
INLET 49" DIA  
CLASS MAX RPM  
825  
1015

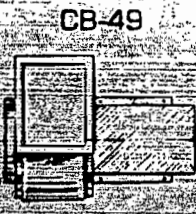

Table for CB-49 showing Volume (GPM) and Capacity (GPM) for various RPM values (725, 625, 525, 425, 325, 225, 125) and Inlet Diameter (49" DIA).

Table for CB-49 showing Capacity (GPM) for various RPM values (725, 625, 525, 425, 325, 225, 125) and Inlet Diameter (49" DIA).



Table for CB-49 showing Capacity (GPM) for various RPM values (725, 625, 525, 425, 325, 225, 125) and Inlet Diameter (49" DIA).

Table for CB-49 showing Capacity (GPM) for various RPM values (725, 625, 525, 425, 325, 225, 125) and Inlet Diameter (49" DIA).

WHEEL 49" DIA  
INLET 54" DIA  
CLASS MAX RPM  
725  
020

USE CAPACITY TABLES AS GUIDE ONLY



*HARRIS SEMICONDUCTOR*

*AIR PERMIT - BUILDING 62*





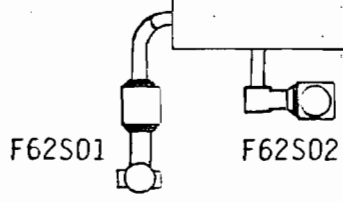
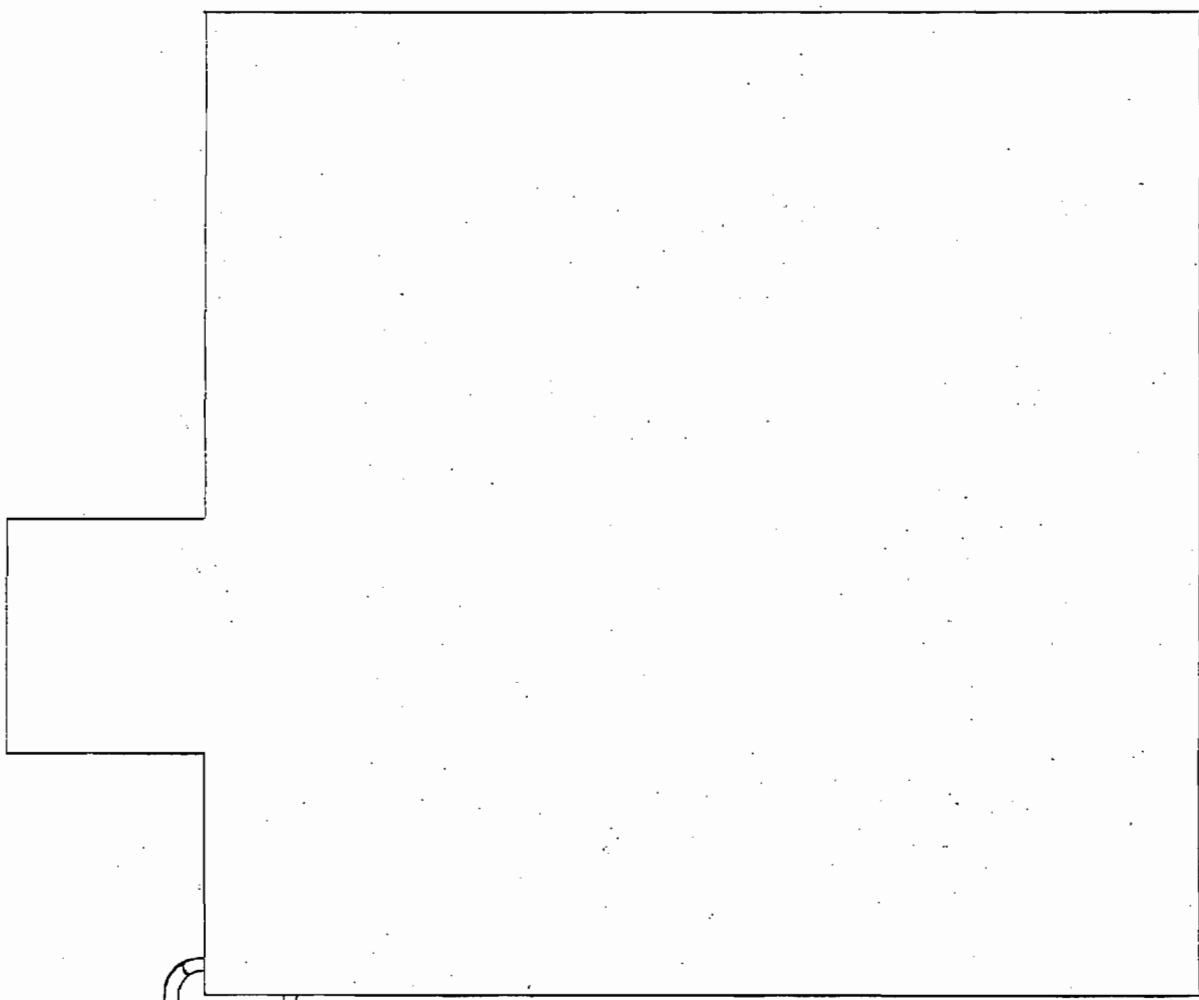
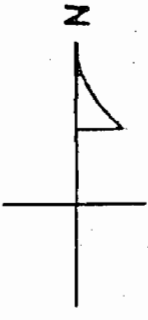

*ATTACHMENT E*

*SITE LOCATION MAPS*

HARRIS SEMICONDUCTOR  
SCRUBBER LOCATIONS  
BUILDING 62



LEGEND

-  - Horizontal Scrubber
-  - Vertical Scrubber
-  - Exhaust Stack
-  - Exhaust Fan
-  - Stack mounted on fan
-  - Epitaxial Scrubber

APOLLO BLVD

# Harris Semiconductor Complex

SCRUBBER LOCATIONS

POND

F62S02  
F62S01

62B

62A

PARKING LOT

F58S02  
F58S01

PARKING LOT

59

58

PARKING LOT

POND

F57S01

PALM BAY BLVD

F59S01  
F59S03

63

54

PARKING LOT

F63S02  
F63S01  
F63S03

F54S03  
F54S04  
F54S01  
F54S02  
F60S01  
F55S01

60

53

F04S05  
F04S06  
F04S01

BORROW PIT

55

52

51

PARKING

PARKING LOT

6

TROUTMAN

N

F61S02  
F61S01

61

PARKING LOT

F51S01  
F51S02  
F51S03  
F51S04  
F51S05

F04S08  
F04S04  
F04S03  
F04S02

LIPSCOMB ST

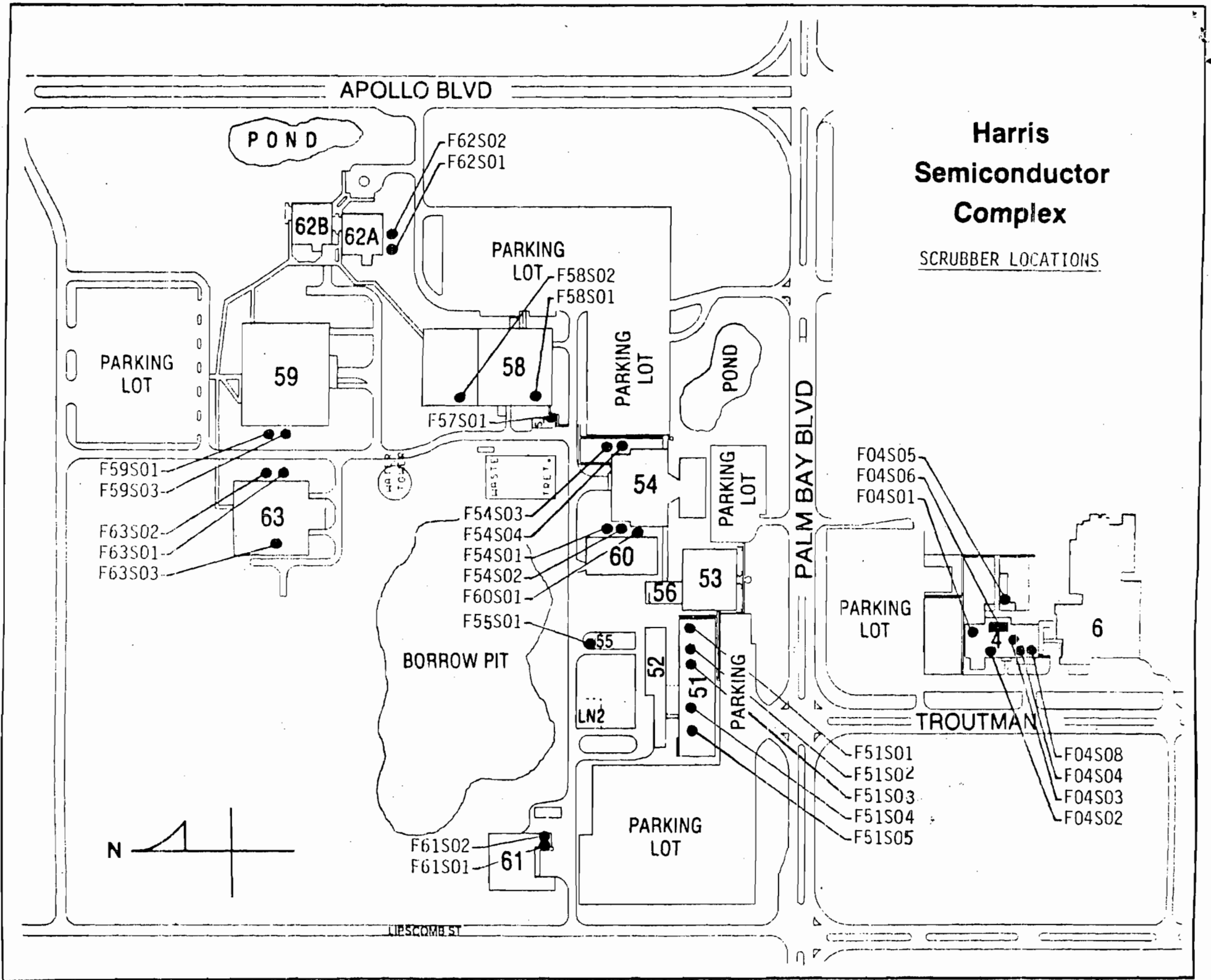



DEPARTMENT OF ENVIRONMENTAL REGULATION

AC 05-15778

WIN TOWERS OFFICE BUILDING  
2600 BLAIR STONE ROAD  
TALLAHASSEE, FLORIDA 32301-8241

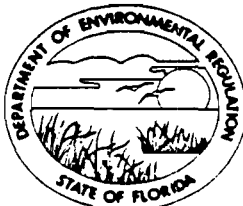

RECEIVED

BOB GRAHAM  
GOVERNOR

NOV 28 1988  
TORIA J. TSCHINKEL  
SECRETARY

DER-BAQM

APPLICATION TO OPERATE/CONSTRUCT AIR POLLUTION SOURCES

SOURCE TYPE: Stationary [ ] New<sup>1</sup> [X] Existing<sup>1</sup>

APPLICATION TYPE: [ ] Construction [ ] Operation [X] Modification

COMPANY NAME: Harris Semiconductor COUNTY: Brevard

Identify the specific emission point source(s) addressed in this application (i.e. Lime Kiln No. 4 with Venturi Scrubber; Peaking Unit No. 2, Gas Fired) B-51 Manufacturing Fab

SOURCE LOCATION: Street Palm Bay Road City Palm Bay

UTM: East 17-538700 North 17-3100900

Latitude 28 ° 01 ' 20 "N Longitude 80 ° 36 ' 10 "W

APPLICANT NAME AND TITLE: J. R. Kolanek; Manager Environmental Services

APPLICANT ADDRESS: P.O. Box 883, Melbourne, Fl 32901

SECTION I: STATEMENTS BY APPLICANT AND ENGINEER

A. APPLICANT

I am the undersigned owner or authorized representative\* of Harris Semiconductor

I certify that the statements made in this application for a modified permit are true, correct and complete to the best of my knowledge and belief. Further, I agree to maintain and operate the pollution control source and pollution control facilities in such a manner as to comply with the provision of Chapter 403, Florida Statutes, and all the rules and regulations of the department and revisions thereof. I also understand that a permit, if granted by the department, will be non-transferable and I will promptly notify the department upon sale or legal transfer of the permitted establishment.

\*Attach letter of authorization

Signed: Jane R. Kolanek

J. R. Kolanek, Manager, Environmental Svcs.  
Name and Title (Please Type)

Date: 10-28-88 Telephone No. (407) 724-7467

B. PROFESSIONAL ENGINEER REGISTERED IN FLORIDA (where required by Chapter 471, F.S.)

This is to certify that the engineering features of this pollution control project have been designed/examined by me and found to be in conformity with modern engineering principles applicable to the treatment and disposal of pollutants characterized in the permit application. There is reasonable assurance, in my professional judgment, that

<sup>1</sup> See Florida Administrative Code Rule 17-2.100(57) and (104)

the pollution control facilities, when properly maintained and operated, will discharge an effluent that complies with all applicable statutes of the State of Florida and the rules and regulations of the department. It is also agreed that the undersigned will furnish, if authorized by the owner, the applicant a set of instructions for the proper maintenance and operation of the pollution control facilities and, if applicable, pollution sources.

MOAB-REC

Signed Lawrence R. Hutker

Lawrence R. Hutker

Name (Please Type)

Harris Semiconductor

Company Name (Please Type)

P.O. Box 883, Melbourne, Florida 32901

Mailing Address (Please Type)

Florida Registration No. 35972 Date: 10-28-88 Telephone No. (407) 729-4655

**SECTION II: GENERAL PROJECT INFORMATION**

1. Describe the nature and extent of the project. Refer to pollution control equipment, and expected improvements in source performance as a result of installation. State whether the project will result in full compliance. Attach additional sheet if necessary.

This is a modification and consolidation of existing air permits.

2. Schedule of project covered in this application (Construction Permit Application Only)

Start of Construction N/A Completion of Construction \_\_\_\_\_

3. Costs of pollution control system(s): (Note: Show breakdown of estimated costs only for individual components/units of the project serving pollution control purposes. Information on actual costs shall be furnished with the application for operation permit.)

N/A

4. Indicate any previous DER permits, orders and notices associated with the emission point, including permit issuance and expiration dates.

A0 05-109853 issued 11/5/85 expires 10/30/90; A0 05-109855 issued 11/5/85 expires 10/30/90;

A0 05-117085 issued 5/20/86 expires 5/22/91; A0 05-71405 issued 9/13/83 expires 9/12/88.

E. Requested permitted equipment operating time: hrs/day 24 ; days/wk 7 ; wks/yr 52 ;  
if power plant, hrs/yr \_\_\_\_\_ ; if seasonal, describe: \_\_\_\_\_  
\_\_\_\_\_  
\_\_\_\_\_

F. If this is a new source or major modification, answer the following questions.  
(Yes or No)

1. Is this source in a non-attainment area for a particular pollutant? No  
a. If yes, has "offset" been applied? \_\_\_\_\_  
b. If yes, has "Lowest Achievable Emission Rate" been applied? \_\_\_\_\_  
c. If yes, list non-attainment pollutants. \_\_\_\_\_

2. Does best available control technology (BACT) apply to this source?  
If yes, see Section VI. No

3. Does the State "Prevention of Significant Deterioration" (PSD)  
requirement apply to this source? If yes, see Sections VI and VII. No

4. Do "Standards of Performance for New Stationary Sources" (NSPS)  
apply to this source? No

5. Do "National Emission Standards for Hazardous Air Pollutants"  
(NESHAP) apply to this source? No

H. Do "Reasonably Available Control Technology" (RACT) requirements apply  
to this source? No

a. If yes, for what pollutants? \_\_\_\_\_

b. If yes, in addition to the information required in this form,  
any information requested in Rule 17-2.650 must be submitted.

Attach all supportive information related to any answer of "Yes". Attach any justifi-  
cation for any answer of "No" that might be considered questionable.

SECTION III: AIR POLLUTION SOURCES & CONTROL DEVICES (Other than Incinerators)

A. Raw Materials and Chemicals Used in your Process, if applicable:

Description	Contaminants		Utilization Rate - lbs/hr	Relate to Flow Diagram
	Type	% Wt		
SEE ATTACHMENT	"C"			

B. Process Rate, if applicable: (See Section V, Item 1)

- Total Process Input Rate (lbs/hr): \_\_\_\_\_
- Product Weight (lbs/hr): \_\_\_\_\_

C. Airborne Contaminants Emitted: (Information in this table must be submitted for each emission point, use additional sheets as necessary)

Name of Contaminant	Emission <sup>1</sup>		Allowed Emission Rate per Rule 17-2	Allowable <sup>3</sup> Emission lbs/hr	Potential <sup>4</sup> Emission		Relate to Flow Diagram
	Maximum lbs/hr	Actual T/yr			lbs/yr	T/yr	
SEE ATTACHMENT	"B"						

<sup>1</sup>See Section V, Item 2.

<sup>2</sup>Reference applicable emission standards and units (e.g. Rule 17-2.600(5)(b)2. Table II, E. (1) - 0.1 pounds per million BTU heat input)

<sup>3</sup>Calculated from operating rate and applicable standard.

<sup>4</sup>Emission, if source operated without control (See Section V, Item 3).

J. Control Devices: (See Section V, Item 4)

Name and Type (Model & Serial No.)	Contaminant	Efficiency	Range of Particles Size Collected (in microns) (If applicable)	Basis for Efficiency (Section V Item 5)
SEE ATTACHMENT	"D"			

E. Fuels Not applicable.

Type (Be Specific)	Consumption*		Maximum Heat Input (MMBTU/hr)
	avg/hr	max./hr	

\*Units: Natural Gas--MMCF/hr; Fuel Oils--gallons/hr; Coal, wood, refuse, other--lbs/hr.

Fuel Analysis:

Percent Sulfur: \_\_\_\_\_ Percent Ash: \_\_\_\_\_

Density: \_\_\_\_\_ lbs/gal Typical Percent Nitrogen: \_\_\_\_\_

Heat Capacity: \_\_\_\_\_ BTU/lb \_\_\_\_\_ BTU/gal

Other Fuel Contaminants (which may cause air pollution): \_\_\_\_\_

F. If applicable, indicate the percent of fuel used for space heating.

Annual Average \_\_\_\_\_ Maximum \_\_\_\_\_

G. Indicate liquid or solid wastes generated and method of disposal.

Waste water from air scrubbers is discharged to on-site waste water treatment plant.

Discharges to deepwell under UIC permit #UC05-126519.

--- SEE ATTACHMENT "D" ---

H. Emission Stack Geometry and Flow Characteristics (Provide data for each stack):

Stack Height: \_\_\_\_\_ ft. Stack Diameter: \_\_\_\_\_ ft.  
 Gas Flow Rate: \_\_\_\_\_ ACFM \_\_\_\_\_ DSCFM Gas Exit Temperature: \_\_\_\_\_ °F.  
 Water Vapor Content: \_\_\_\_\_ % Velocity: \_\_\_\_\_ FPS

SECTION IV: INCINERATOR INFORMATION  
 NOT APPLICABLE

Type of Waste	Type 0 (Plastics)	Type I (Rubbish)	Type II (Refuse)	Type III (Garbage)	Type IV (Pathological)	Type V (Liq. & Gas By-prod.)	Type VI (Solid By-prod.)
Actual lb/hr Incinerated							
Uncontrolled (lbs/hr)							

Description of Waste: \_\_\_\_\_

Total Weight Incinerated (lbs/hr) \_\_\_\_\_ Design Capacity (lbs/hr) \_\_\_\_\_

Approximate Number of Hours of Operation per day \_\_\_\_\_ day/wk \_\_\_\_\_ wks/yr. \_\_\_\_\_

Manufacturer: \_\_\_\_\_

Date Constructed \_\_\_\_\_ Model No. \_\_\_\_\_

	Volume (ft) <sup>3</sup>	Heat Release (BTU/hr)	Fuel		Temperature (°F)
			Type	BTU/hr	
Primary Chamber					
Secondary Chamber					

Stack Height: \_\_\_\_\_ ft. Stack Diameter: \_\_\_\_\_ Stack Temp. \_\_\_\_\_

Gas Flow Rate: \_\_\_\_\_ ACFM \_\_\_\_\_ DSCFM\* Velocity: \_\_\_\_\_ FPS

\*If 50 or more tons per day design capacity, submit the emissions rate in grains per standard cubic foot dry gas corrected to 50% excess air.

Type of pollution control device: [ ] Cyclone [ ] Wet Scrubber [ ] Afterburner  
 [ ] Other (specify) \_\_\_\_\_

Brief description of operating characteristics of control devices: \_\_\_\_\_

\_\_\_\_\_  
\_\_\_\_\_  
\_\_\_\_\_  
\_\_\_\_\_  
Ultimate disposal of any effluent other than that emitted from the stack (scrubber water, ash, etc.):

\_\_\_\_\_  
\_\_\_\_\_  
\_\_\_\_\_  
NOTE: Items 2, 3, 4, 6, 7, 8, and 10 in Section V must be included where applicable.

**SECTION V: SUPPLEMENTAL REQUIREMENTS**

Please provide the following supplements where required for this application.

1. Total process input rate and product weight -- show derivation [Rule 17-2.100(127)]
2. To a construction application, attach basis of emission estimate (e.g., design calculations, design drawings, pertinent manufacturer's test data, etc.) and attach proposed methods (e.g., FR Part 60 Methods 1, 2, 3, 4, 5) to show proof of compliance with applicable standards. To an operation application, attach test results or methods used to show proof of compliance. Information provided when applying for an operation permit from a construction permit shall be indicative of the time at which the test was made.
3. Attach basis of potential discharge (e.g., emission factor, that is, AP42 test).
4. With construction permit application, include design details for all air pollution control systems (e.g., for baghouse include cloth to air ratio; for scrubber include cross-section sketch, design pressure drop, etc.)
5. With construction permit application, attach derivation of control device(s) efficiency. Include test or design data. Items 2, 3 and 5 should be consistent: actual emissions = potential (1-efficiency).
6. An 8 1/2" x 11" flow diagram which will, without revealing trade secrets, identify the individual operations and/or processes. Indicate where raw materials enter, where solid and liquid waste exit, where gaseous emissions and/or airborne particles are evolved and where finished products are obtained.
7. An 8 1/2" x 11" plot plan showing the location of the establishment, and points of airborne emissions, in relation to the surrounding area, residences and other permanent structures and roadways (Example: Copy of relevant portion of USGS topographic map).
8. An 8 1/2" x 11" plot plan of facility showing the location of manufacturing processes and outlets for airborne emissions. Relate all flows to the flow diagram.

9. The appropriate application fee in accordance with Rule 17-4.05. The check should be made payable to the Department of Environmental Regulation.
10. With an application for operation permit, attach a Certificate of Completion of Construction indicating that the source was constructed as shown in the construction permit.

**SECTION VI: BEST AVAILABLE CONTROL TECHNOLOGY**

A. Are standards of performance for new stationary sources pursuant to 40 C.F.R. Part 60 applicable to the source?

Yes  No

Contaminant	Rate or Concentration

B. Has EPA declared the best available control technology for this class of sources (if yes, attach copy)

Yes  No

Contaminant	Rate or Concentration

C. What emission levels do you propose as best available control technology?

Contaminant	Rate or Concentration

D. Describe the existing control and treatment technology (if any).

- |                           |                          |
|---------------------------|--------------------------|
| 1. Control Device/System: | 2. Operating Principles: |
| 3. Efficiency:*           | 4. Capital Costs:        |

\*Explain method of determining



- 5. Useful Life:
- 7. Energy:
- 9. Emissions:

- 6. Operating Costs:
- 8. Maintenance Cost:

Contaminant	Rate or Concentration

10. Stack Parameters

- a. Height: ft.    b. Diameter: ft.
- c. Flow Rate: ACFM    d. Temperature: °F.
- e. Velocity: FPS

E. Describe the control and treatment technology available (As many types as applicable, use additional pages if necessary).

1.

- a. Control Device: b. Operating Principles:
- c. Efficiency:<sup>1</sup> d. Capital Cost:
- e. Useful Life: f. Operating Cost:
- g. Energy:<sup>2</sup> h. Maintenance Cost:
- i. Availability of construction materials and process chemicals:
- j. Applicability to manufacturing processes:
- k. Ability to construct with control device, install in available space, and operate within proposed levels:

2.

- a. Control Device: b. Operating Principles:
- c. Efficiency:<sup>1</sup> d. Capital Cost:
- e. Useful Life: f. Operating Cost:
- g. Energy:<sup>2</sup> h. Maintenance Cost:
- i. Availability of construction materials and process chemicals:

<sup>1</sup>Explain method of determining efficiency.  
<sup>2</sup>Energy to be reported in units of electrical power - KWH design rate.

j. Applicability to manufacturing processes:

k. Ability to construct with control device, install in available space, and operate within proposed levels:

3.

a. Control Device:

b. Operating Principles:

c. Efficiency:<sup>1</sup>

d. Capital Cost:

e. Useful Life:

f. Operating Cost:

g. Energy:<sup>2</sup>

h. Maintenance Cost:

i. Availability of construction materials and process chemicals:

j. Applicability to manufacturing processes:

k. Ability to construct with control device, install in available space, and operate within proposed levels:

4.

a. Control Device:

b. Operating Principles:

c. Efficiency:<sup>1</sup>

d. Capital Costs:

e. Useful Life:

f. Operating Cost:

g. Energy:<sup>2</sup>

h. Maintenance Cost:

i. Availability of construction materials and process chemicals:

j. Applicability to manufacturing processes:

k. Ability to construct with control device, install in available space, and operate within proposed levels:

F. Describe the control technology selected:

1. Control Device:

2. Efficiency:<sup>1</sup>

3. Capital Cost:

4. Useful Life:

5. Operating Cost:

6. Energy:<sup>2</sup>

7. Maintenance Cost:

8. Manufacturer:

9. Other locations where employed on similar processes:

a. (1) Company:

(2) Mailing Address:

(3) City:

(4) State:

Explain method of determining efficiency.

Energy to be reported in units of electrical power - KWH design rate.

(5) Environmental Manager:

(6) Telephone No.:

(7) Emissions:<sup>1</sup>

Contaminant

Rate or Concentration

(8) Process Rate:<sup>1</sup>

b. (1) Company:

(2) Mailing Address:

(3) City:

(4) State:

(5) Environmental Manager:

(6) Telephone No.:

(7) Emissions:<sup>1</sup>

Contaminant

Rate or Concentration

(8) Process Rate:<sup>1</sup>

10. Reason for selection and description of systems:

<sup>1</sup>Applicant must provide this information when available. Should this information not be available, applicant must state the reason(s) why.

**SECTION VII - PREVENTION OF SIGNIFICANT DETERIORATION**

**A. Company Monitored Data**

1. \_\_\_\_\_ no. sites \_\_\_\_\_ TSP \_\_\_\_\_ ( ) SO<sub>2</sub>\* \_\_\_\_\_ Wind spd/dir

Period of Monitoring \_\_\_\_\_ / \_\_\_\_\_ / \_\_\_\_\_ to \_\_\_\_\_ / \_\_\_\_\_ / \_\_\_\_\_  
month day year month day year

Other data recorded \_\_\_\_\_

Attach all data or statistical summaries to this application.

Specify bubbler (B) or continuous (C).

2. Instrumentation, Field and Laboratory

- a. Was instrumentation EPA referenced or its equivalent?  Yes  No
- b. Was instrumentation calibrated in accordance with Department procedures?  
 Yes  No  Unknown

B. Meteorological Data Used for Air Quality Modeling

- 1. \_\_\_\_\_ Year(s) of data from \_\_\_\_\_ / \_\_\_\_\_ / \_\_\_\_\_ to \_\_\_\_\_ / \_\_\_\_\_ / \_\_\_\_\_  
month day year month day year
- 2. Surface data obtained from (location) \_\_\_\_\_
- 3. Upper air (mixing height) data obtained from (location) \_\_\_\_\_
- 4. Stability wind rose (STAR) data obtained from (location) \_\_\_\_\_

C. Computer Models Used

- 1. \_\_\_\_\_ Modified? If yes, attach description.
- 2. \_\_\_\_\_ Modified? If yes, attach description.
- 3. \_\_\_\_\_ Modified? If yes, attach description.
- 4. \_\_\_\_\_ Modified? If yes, attach description.

Attach copies of all final model runs showing input data, receptor locations, and principle output tables.

D. Applicants Maximum Allowable Emission Data

Pollutant	Emission Rate
TSP	_____ grams/sec
SO <sub>2</sub>	_____ grams/sec

E. Emission Data Used in Modeling

Attach list of emission sources. Emission data required is source name, description of point source (on NEDS point number), UTM coordinates, stack data, allowable emissions, and normal operating time.

F. Attach all other information supportive to the PSD review.

G. Discuss the social and economic impact of the selected technology versus other applicable technologies (i.e., jobs, payroll, production, taxes, energy, etc.). Include assessment of the environmental impact of the sources.

H. Attach scientific, engineering, and technical material, reports, publications, journals, and other competent relevant information describing the theory and application of the requested best available control technology.

*HARRIS SEMICONDUCTOR*  
*AIR PERMIT - BUILDING 51*  
*ATTACHMENT A*  
*PROCESS DESCRIPTION*

## Attachment A

Building 51 is a wafer fabrication facility. The second floor of the two-story building houses two clean room modules. Both fabrication areas employ a series of manufacturing procedures referred to as layering, patterning, doping and heating processes. The frequency and sequence of these processes can vary depending on the desired nature of the final product.

In the controlled environment of the fabrication clean rooms, wafer surfaces first undergo acid and/or solvent cleaning, followed by thermal oxidation in furnaces to form a layer of silicon dioxide on the wafer surface.

During the patterning process, the wafers are initially baked and primed. Coaters then spin a thin layer of "photoresist" on the wafer, after which the wafers are soft baked. Next, the circuit pattern is projected onto the wafers via "aligners" or "steppers." Developers are then applied to remove unpolymerized areas of photoresist. This is followed by a solvent rinse.

Next, the wafers hard-baked, inspected to determine accuracy, and etched by wet (acid bath) or dry (plasma vapor) mechanisms. Once etching is complete, the photoresist is stripped off the wafer using chemical baths or plasma techniques.

In another step of the fabrication process, "dopant" atoms are either diffused into the wafer in diffusion furnaces, or accelerated into the wafer using "ion implantation." Fumes from the vapor deposition furnaces are oxidized in "burn boxes." Additional material may be layered on the wafer surface in vapor and crystal (epitaxial) deposition furnaces. Metallization to interconnect uppermost circuit layers is performed by deposition (using "sputtering" systems) or evaporation.

Wet stations that house vats containing a variety of acid and caustic compounds are located throughout the clean rooms. Building 51 utilizes approximately 50 stations, one-third of which contain vats of solvent-based chemicals. Less than one-quarter of these solvent stations are heated. Previously, no covers were used on the vats. However, stainless steel covers are presently being serviced to fit all vats containing solvents in the fabrication area.

Gas cabinets, vacuum pumps and chemical drains are located in areas dedicated to the containment of these exhausted units. Storage cabinets safely hold virgin chemicals until they are ready for use.

The exhaust system for the building is divided amongst five scrubbers. The scrubbers numbered F51S01, F51S02, and F51S03 serve the east module, while F51S04 and F51S05 serve the west module. Scrubbers numbered F51S01, F51S03 and F51S04 are acid scrubbers, while F51S02 and F51S05 provide pollution control and exhaust for equipment containing solvents.

*HARRIS SEMICONDUCTOR*  
*AIR PERMIT – BUILDING 51*

*ATTACHMENT B*

*AIR EMISSIONS*

## ACID MONITORING--BUILDING 51

Monitoring was performed on the building 51 acid scrubber systems in August of 1988. Samples were collected using a modified EPA method 8 sampling train. The impinger medium consisted of a 0.1 N sodium hydroxide solution. The analytical methodology utilized to determine the ions of highest concentration is as follows;

Chloride ion--EPA Method 325.3

Fluoride ion--EPA Method 340.2

Nitrate, phosphite, and sulfate ions--ion chromatography

All results were in pounds per hour as "X", where "X" represents the acid compound present in highest concentration.

The test results revealed that the total accumulative monitored acid emissions for the building were 3.7318 tons/year expressed as hydrochloric, hydrofluoric, nitric, phosphoric and sulfuric acids. This figure is based on a hypothetical production schedule of 8760 hours a year. The monitoring was performed over an 8 hour time interval when the full production was occurring.

When a resulting acid concentration was expressed as a "less than 'y' " value, where 'y' represents the lowest detectable limit possible using the analytical methodology employed, acid emissions were taken to be equal to this 'y' limit value.



RESULTS OF ACID MONITORING--BUILDING 51  
PERFORMED IN AUGUST OF 1988

Scrubber #	HCl	HF	Nitric Acid	Phosphoric Acid	Sulfuric Acid	TOTAL (TON/YR)
F51S01 outlet (lb/hr)	0.0130	0.0010	0.0060	0.0030	0.0040	
(ton/yr)	0.0569	0.0044	0.0263	0.0131	0.0175	0.1183
F51S03 outlet (lb/hr)	0.0160	0.0190	0.2510	0.0110	0.0120	
(ton/yr)	0.0701	0.0832	1.0994	0.0482	0.0526	1.3534
F51S04 outlet (lb/hr)	0.0280	0.0320	0.4360	0.0070	0.0130	
(ton/yr)	0.1226	0.1402	1.9097	0.0307	0.0569	2.2601
						3.7318

TOTAL ACID EMISSIONS INTO SCRUBBER OUTLETS = 3.7318 TONS/YEAR

## SOLVENT MONITORING--BUILDING 51

Monitoring work was conducted on the building 51 solvent scrubber systems F51S02, F51S03, F51S04, & F51S05 in November of 1987. Tests employed were EPA methods 25A (flame ionization detection) and TO-1 (Tenax adsorption and GC/ms analysis.)

FID test results revealed that total accumulative monitored VOC emissions for the building were 33.29 tons/year expressed as propane. This figure is based on a hypothetical production schedule of 8760 hours a year. The following assumptions were made regarding monitoring work on this building:

-VOC values refer to all organic emissions including organic solvents.

-All data was corrected for 2 ppm background noise that is normally present in the ambient air.

-The F.I.D. accumulative emission figure is based on the maximum concentration of VOC's observed during the monitoring time frame.

TOTAL VOC EMISSIONS FROM BUILDING 51  
AS DETECTED BY EPA METHOD 25-A  
NOVEMBER, 1987

SCRUB#	PRODUCTN SCHEDULE	PRODUCTN EMISSIONS (TON/YR)
F51S02	8760	11.39
F51S03	8760	3.72
F51S04	8760	1.71
F51S05	8760	16.47
		33.29

TOTAL PROJECTED VOC EMISSIONS FOR BLDG. 51 = 33.29 TONS/YEAR

EPA METHOD TO-1: GC/MASS SPEC ANALYSIS OF SCRUBBER EMISSIONS  
NOVEMBER RESULTS-

	-----SCRUBBER #-----			
	F51S02	F51S03	F51S04	F51S05
ACETONE (LB/HR)	0.58	---	---	0.60
XYLENES (LB/HR)	0.02	---	0.11	1.00
ETHYL BENZENE (LB/HR)	---	---	---	0.14
1,2-DICHLOROBENZENE (LB/HR)	---	---	---	---
1,1-DICHLOROETHENE (LB/HR)	---	---	---	---
TETRACHLOROETHENE (LB/HR)	---	---	---	---
1,1,1-TRICHLOROETHANE (LB/HR)	---	---	---	---

*HARRIS SEMICONDUCTOR*

*AIR PERMIT – BUILDING 51*

*ATTACHMENT C*

*RAW MATERIALS AND CHEMICALS*

PROCESS GASES

---

1. ALUMINUM OXIDE
2. ARGON
3. ARSINE
4. BORON TRIFLUORIDE
5. SULFUR HEXAFLUORIDE
6. CARBON DIOXIDE
7. DICHLOROSILANE
8. HELIUM
9. NITROGEN
10. NITROUS OXIDE
11. OXYGEN
12. PHOSPHINE
13. SILANE
14. ARSENIC
15. BORON TRIBROMIDE
16. NITROGEN DIOXIDE
17. HYDROGEN CHLORIDE
18. PHOSPHORUS TRICHLORIDE
19. HYDROGEN

## PROCESS CHEMICALS

---

1. AMMONIA
2. AMMONIUM HYDROXIDE
3. AMMONIUM FLUORIDE
4. POTASSIUM HYDROXIDE
5. SODIUM HYDROXIDE
6. SULFURIC ACID
7. CERIC SULFATE
8. DICHLOROBENZENE
9. CHROMIUM TRIOXIDE
10. COPPER SULFATE
11. TETRAMETHYL AMMONIUM HYDROXIDE
12. DIMETHYLPOLYSILOXANE
13. NITRIC ACID
14. PHOSPHORIC ACID
15. CHROMIC ACID
16. HYDROFLUORIC ACID
17. ACETIC ACID
18. ETHYLENE DIAMINE TETRAACETIC ACID
19. SILICON
20. CHROMIUM TRIOXIDE
21. GUM RESIN
22. PHENOL-FORMALDEHYDE RESIN
23. HYDROGEN PEROXIDE
24. HEXAMETHYLDISILAZANE
25. DODECYLBENZENESULFONIC ACID
26. PHOSPHATE
27. FERRIC CHLORIDE

## PROCESS CHEMICALS

### SOLVENTS

---

1. 1,1,1 TRICHLOROETHANE
2. ACETONE
3. BUTYL CELLOSOLVE
4. AROMATIC PHENOL
5. 1,2,4 TRICHLOROBENZENE
6. XYLENE
7. CELLOSOLVE ACETATE
8. ISOPARAFFINIC HYDROCARBONS
9. DICHLORODIFLUOROMETHANE
10. ETHANOLAMINE
11. METHYLENE CHLORIDE
12. ISOPROPANOL
13. PROPYLENE GLYCOL MONOETHYL ETHER ACETATE
14. PROPYLENE GLYCOL MONOMETHYL ETHER
15. ETHYLENE GLYCOL MONOETHYL ETHER ACETATE
16. ETHYLENE GLYCOL MONOBUTYL ETHER
17. TETRAFLUOROMETHANE
18. CHLOROPENTAFLUOROETHANE
19. CHLOROTRIFLUOROMETHANE
20. ETHANOL
21. TRICHLOROTRIFLUOROETHANE
22. TRICHLOROTRIFLUOROMETHANE
23. TRICHLORODIFLUOROETHANE
24. METHANOL
25. GLYCOL ETHER
26. MONOETHANOLAMINE
27. METHYL ETHYL KETONE
28. TETRAFLUROETHANE
29. N-BUTYL ACETATE
30. 2-ETHOXYETHYL ACETATE
31. ETHYL BENZENE
32. POLYPHENYL ETHER
33. AMMONIUM FLUORIDE
34. 1-METHOXY-2-PROPANOL
35. 2-METHOXY-2-PROPANOL

*HARRIS SEMICONDUCTOR*  
*AIR PERMIT – BUILDING 51*  
*ATTACHMENT D*  
*CONTROL EQUIPMENT*



## HARRIS SEMICONDUCTOR

## -- AIR PERMIT INFORMATION

CURRENT PERMIT

BUILDING: 51  
PERMIT NUMBER: AO 05-117085  
PERMIT TYPE : OPERATING

DATE ISSUED : 05/20/86  
RENEWAL DATE: 03/23/91  
DATE EXPIRES: 05/22/91

AREA SERVED: ANALOG EXPANSION  
PROCESS DESCRIPTION: EXHAUST SYSTEM SCRUBBER

PERMIT LIMITS

VOL. RATE (SCFM): 9,500  
ACID MIST (LB/HR): 0.0437  
SOLVENTS (LB/HR): --  
VOCS (LB/HR): --  
OPER. (HRS/YEAR): 6336

SPECIFIC CONDITIONS

ANNUAL OPERATING REPORT : 03/01  
NOTIFICATION OF VE TEST : NOT SPEC.  
ANNUAL VIS EMISSION TEST: NOT SPEC.

EQUIPMENT INFORMATION

MANUFACTURER : TRI-MER CORP.  
LOCATION : B51 ROOF  
HARRIS ID NUMBER : F51S01  
VOLUME FLOW RATE (CFM): 9,500  
RECIRCULATION RATE (GPM): 30  
MAKEUP WATER RATE (GPM): 3.0

MODEL NUMBER : F/W 3  
STACK HEIGHT (FT):  
STACK DIAMETER (IN):  
STACK VELOCITY (FPM):  
DUCT MATERIAL :

PERMIT HISTORY

PERMIT NUMBER: AO 05-38487  
DATE EXPIRED : 04/08/86

PERMIT NUMBER:  
DATE EXPIRED :

PERMIT NUMBER:  
DATE EXPIRED :

SCRUBBER INFORMATION

HARRIS ID # : F51S01  
MANUFACTURER : TRI-MER CORP. MODEL NUMBER : F/W 3  
SERIAL NUMBER: 7026 MATERIAL : PVC  
DESCRIPTION : HORIZONTAL COUNTER-FLOW, MIST ELIMINATOR,  
POLYPRO FILTER PACK; DRAWING D1000-585 (6/80)

DESIGN DATA

VOLUME FLOW RATE (CFM): 9,500 PRESSURE DROP (IN):  
RECIRCULATION RATE (GPM): 30 MAKE UP RATE (GPM): 3.0

ACTUAL DATA

VOLUME FLOW RATE (CFM): PRESSURE DROP (IN): N/E DATE: 6/3/87  
RECIRCULATION RATE (GPM): N/E MAKE UP RATE (GPM): N/R DATE: "

RECIRCULATION PUMP INFORMATION

MANUFACTURER : FLOTEK MODEL NUMBER : C7P3-1194V  
SERIAL NUMBER: 603887B801 HP : 1 RPM : 3450/2850  
BRKR LOCATION: NEXT TO UNIT FED FROM MCC : TAC 76127

FAN INFORMATION

HARRIS ID # : F51E13  
MANUFACTURER : TRI-MER CORP. MODEL NUMBER: 24 UB  
SERIAL NUMBER: 7026 MATERIAL : PVC  
DESCRIPTION : CENTRIFUGAL BLOWER, BACKWARD INCLINED BLADES

DESIGN DATA

VOLUME FLOW RATE (CFM): 6,000 STATIC PRESS (IN):

ACTUAL DATA

VOLUME FLOW RATE (CFM): SPEED (RPM): DATE:  
STATIC PRESS (IN): DATE:

FAN MOTOR INFORMATION

MANUFACTURER : LINCOLN MODEL NUMBER :  
SERIAL NUMBER: HP : 15 RPM : 1750  
BRKR LOCATION: NEXT TO UNIT FED FROM MCC : TAC 76127

HARRIS SEMICONDUCTOR --

AIR PERMIT INFORMATION

CURRENT PERMIT

BUILDING: 51  
PERMIT NUMBER: AO 05-109855  
PERMIT TYPE : OPERATING

DATE ISSUED : 11/05/85  
RENEWAL DATE: 08/31/90  
DATE EXPIRES: 10/30/90

AREA SERVED:

PROCESS DESCRIPTION: SILICON WAFER CHEM TREAT AIR WASHER (SYS 6)

PERMIT LIMITS

VOL. RATE (SCFM): 10,000  
ACID MIST (LB/HR): --  
SOLVENTS (LB/HR): --  
VOCS (LB/HR): 1.246  
OPER. (HRS/YEAR): 6336

SPECIFIC CONDITIONS

ANNUAL OPERATING REPORT : 03/01  
NOTIFICATION OF VE TEST : 11/06  
ANNUAL VIS EMISSION TEST: 11/21

EQUIPMENT INFORMATION

MANUFACTURER : DUAL IND.  
LOCATION : B51 PENTHOUSE  
HARRIS ID NUMBER : F51S02  
VOLUME FLOW RATE (CFM): 10,000  
RECIRCULATION RATE (GPM): 30  
MAKEUP WATER RATE (GPM): 1.5

MODEL NUMBER : F-101  
STACK HEIGHT (FT):  
STACK DIAMETER (IN):  
STACK VELOCITY (FPM):  
DUCT MATERIAL :

PERMIT HISTORY

PERMIT NUMBER: AO 05-36166  
DATE EXPIRED :

PERMIT NUMBER:  
DATE EXPIRED :

PERMIT NUMBER:  
DATE EXPIRED :

SCRUBBER INFORMATION

HARRIS ID # : F51S02  
MANUFACTURER : DUALL IND. MODEL NUMBER : F-101  
SERIAL NUMBER: 4476 MATERIAL : PVC  
DESCRIPTION : HORIZONTAL CROSS-FLOW, FOUR STAGE, MIST ELIMINATOR,  
SINGLE FILTER PACK, OPEN ORIFICE TYPE SPRAY NOZZLES

DESIGN DATA

VOLUME FLOW RATE (CFM): 10,000 PRESSURE DROP (IN): 2.0  
RECIRCULATION RATE (GPM): 30 MAKE UP RATE (GPM): 1.5

ACTUAL DATA

VOLUME FLOW RATE (CFM): 8,200 PRESSURE DROP (IN): N/E DATE: 1/16/87  
RECIRCULATION RATE (GPM): 12 MAKE UP RATE (GPM): N/E DATE: 6/3/87

RECIRCULATION PUMP INFORMATION

MANUFACTURER : GENERAL ELECT. MODEL NUMBER : 5K47SG976  
SERIAL NUMBER: N/A HP : 2 RPM : 3450  
BRKR LOCATION: FED FROM MCC :

FAN INFORMATION

HARRIS ID # : F51E18  
MANUFACTURER : DUALL IND. MODEL NUMBER: 49  
SERIAL NUMBER: 4476 MATERIAL : PVC  
DESCRIPTION : CENTRIFUGAL BLOWER

DESIGN DATA

VOLUME FLOW RATE (CFM): 10,000 STATIC PRESS (IN):

ACTUAL DATA

VOLUME FLOW RATE (CFM): 8,200 SPEED (RPM): DATE:  
STATIC PRESS (IN): 4.3 DATE: 1/16/87

FAN MOTOR INFORMATION

MANUFACTURER : MODEL NUMBER :  
SERIAL NUMBER: HP : 15 RPM : 1750  
BRKR LOCATION: FED FROM MCC :

Attachment :

## HARRIS SEMICONDUCTOR

## -- AIR PERMIT INFORMATION

CURRENT PERMIT

BUILDING: 51  
PERMIT NUMBER: AO 05-109853  
PERMIT TYPE : OPERATING

DATE ISSUED : 11/05/85  
RENEWAL DATE: 08/31/90  
DATE EXPIRES: 10/30/90

## AREA SERVED:

PROCESS DESCRIPTION: SILICON WAFER CHEM TREAT AIR WASHER (SYS 3 AND 5)

PERMIT LIMITS

VOL. RATE (SCFM): 24,000  
ACID MIST (LB/HR): 0.0649  
SOLVENTS (LB/HR): --  
VOCs (LB/HR): 0.0174  
OPER. (HRS/YEAR): 6336

SPECIFIC CONDITIONS

ANNUAL OPERATING REPORT : 03/01  
NOTIFICATION OF VE TEST : 11/06  
ANNUAL VIS EMISSION TEST: 11/21

EQUIPMENT INFORMATION

MANUFACTURER : DUALL IND.  
LOCATION : B51 PENTHOUSE  
HARRIS ID NUMBER : F51S03  
VOLUME FLOW RATE (CFM): 24,000  
RECIRCULATION RATE (GPM): 72  
MAKEUP WATER RATE (GPM): 4.0

MODEL NUMBER : F-101  
STACK HEIGHT (FT):  
STACK DIAMETER (IN):  
STACK VELOCITY (FPM):  
DUCT MATERIAL :

PERMIT HISTORY

PERMIT NUMBER: AO 05-36165  
DATE EXPIRED :

PERMIT NUMBER:  
DATE EXPIRED :

PERMIT NUMBER:  
DATE EXPIRED :

SCRUBBER INFORMATION

HARRIS ID # : F51S03  
MANUFACTURER : DUALL IND. MODEL NUMBER : F-101  
SERIAL NUMBER: 4194 MATERIAL : PVC  
DESCRIPTION : HORIZONTAL CROSS-FLOW, FOUR STAGE, MIST ELIMINATOR,  
SINGLE FILTER PACK, OPEN ORIFICE TYPE SPRAY NOZZLES

DESIGN DATA

VOLUME FLOW RATE (CFM): 24,000 PRESSURE DROP (IN): 2.0  
RECIRCULATION RATE (GPM): 72 MAKE UP RATE (GPM): 4.0

ACTUAL DATA

VOLUME FLOW RATE (CFM): PRESSURE DROP (IN): N/E DATE: 6/3/87  
RECIRCULATION RATE (GPM): N/E MAKE UP RATE (GPM): N/E DATE: "

RECIRCULATION PUMP INFORMATION

MANUFACTURER : LINCOLN MODEL NUMBER : 2509  
SERIAL NUMBER: 1605666 3420 HP : 1.5 RPM : 3420  
BRKR LOCATION: FED FROM MCC : #5

FAN INFORMATION

HARRIS ID # : F51E03  
MANUFACTURER : TRI-MER CORP. MODEL NUMBER: 44 CW  
SERIAL NUMBER: 5303 MATERIAL : PVC  
DESCRIPTION : CENTRIFUGAL BLOWER, BACKWARD INCLINED BLADES

DESIGN DATA

VOLUME FLOW RATE (CFM): 30,000 STATIC PRESS (IN):

ACTUAL DATA

VOLUME FLOW RATE (CFM): SPEED (RPM): DATE:  
STATIC PRESS (IN): DATE:

FAN MOTOR INFORMATION

MANUFACTURER : MODEL NUMBER :  
SERIAL NUMBER: HP : 30 RPM : 1750  
BRKR LOCATION: FED FROM MCC : #5

## HARRIS SEMICONDUCTOR

## -- AIR PERMIT INFORMATION

CURRENT PERMIT

BUILDING: 51  
PERMIT NUMBER: AO 05-109853  
PERMIT TYPE : OPERATING

DATE ISSUED : 11/05/85  
RENEWAL DATE: 08/31/90  
DATE EXPIRES: 10/30/90

## AREA SERVED:

PROCESS DESCRIPTION: SILICON WAFER CHEM TREAT AIR WASHER (SYS 3 AND 5)

PERMIT LIMITS

VOL. RATE (SCFM): 24.000  
ACID MIST (LB/HR): 0.0649  
SOLVENTS (LB/HR): --  
VOCS (LB/HR): 0.0174  
OPER. (HRS/YEAR): 6336

SPECIFIC CONDITIONS

ANNUAL OPERATING REPORT : 03/01  
NOTIFICATION OF VE TEST : 11/06  
ANNUAL VIS EMISSION TEST: 11/21

EQUIPMENT INFORMATION

MANUFACTURER :  
LOCATION : B51 PENTHOUSE  
HARRIS ID NUMBER : F51S04  
VOLUME FLOW RATE (CFM): 12,100  
RECIRCULATION RATE (GPM):  
MAKEUP WATER RATE (GPM):

MODEL NUMBER :  
STACK HEIGHT (FT):  
STACK DIAMETER (IN):  
STACK VELOCITY (FPM):  
DUCT MATERIAL :

PERMIT HISTORY

PERMIT NUMBER: 36163  
DATE EXPIRED : 11/21/85

PERMIT NUMBER:  
DATE EXPIRED :

PERMIT NUMBER:  
DATE EXPIRED :

SCRUBBER INFORMATION

HARRIS ID # : F51S04  
MANUFACTURER : DUALL IND. MODEL NUMBER : F-101  
SERIAL NUMBER: 4194 MATERIAL : PVC  
DESCRIPTION : HORIZONTAL CROSS-FLOW, FOUR STAGE, MIST ELIMINATOR,  
SINGLE FILTER PACK, OPEN ORIFICE TYPE SPRAY NOZZLES

DESIGN DATA

VOLUME FLOW RATE (CFM): 24,000 PRESSURE DROP (IN):  
RECIRCULATION RATE (GPM): 72 MAKE UP RATE (GPM): 4.0

ACTUAL DATA

VOLUME FLOW RATE (CFM): PRESSURE DROP (IN): N/E DATE: 6/3/87  
RECIRCULATION RATE (GPM): N/E MAKE UP RATE (GPM): N/E DATE: "

RECIRCULATION PUMP INFORMATION

MANUFACTURER : LINCOLN MODEL NUMBER : 2500  
SERIAL NUMBER: 1597787 HP : 1.5 RPM : 3420  
BRKR LOCATION: FED FROM MCC : #5

FAN INFORMATION

HARRIS ID # :  
MANUFACTURER : HARTZELL MODEL NUMBER: 41-40-GR3  
SERIAL NUMBER: 15530 MATERIAL : FIBERGLASS  
DESCRIPTION : CENTRIFUGAL BLOWER, BACKWARD CURVED BLADES

DESIGN DATA

VOLUME FLOW RATE (CFM): 24500 STATIC PRESS (IN):

ACTUAL DATA

VOLUME FLOW RATE (CFM): SPEED (RPM): DATE:  
STATIC PRESS (IN): DATE:

FAN MOTOR INFORMATION

MANUFACTURER : MODEL NUMBER :  
SERIAL NUMBER: HP : 30 RPM :  
BRKR LOCATION: FED FROM MCC : #5

Attachment :



HARRIS SEMICONDUCTOR

-- AIR PERMIT INFORMATION

CURRENT PERMIT

BUILDING: 51  
PERMIT NUMBER: AO 05-71405  
PERMIT TYPE : OPERATING

DATE ISSUED : 09/13/83  
RENEWAL DATE: 07/14/88  
DATE EXPIRES: 09/12/88

AREA SERVED:

PROCESS DESCRIPTION: SILICON WAFER CHEM TREAT SOLVENT SCRUBBER (SYS 6)

PERMIT LIMITS

VOL. RATE (SCFM): NOT SPEC.  
ACID MIST (LB/HR): --  
SOLVENTS (LB/HR): 0.0893  
VOCS (LB/HR): 0.0008  
OPER. (HRS/YEAR): 6336

SPECIFIC CONDITIONS

ANNUAL OPERATING REPORT : 03/01  
NOTIFICATION OF VE TEST : 08/10  
ANNUAL VIS EMISSION TEST: 08/20

EQUIPMENT INFORMATION

MANUFACTURER : HARRISON  
LOCATION : B51 PENTHOUSE  
HARRIS ID NUMBER : F51S05  
VOLUME FLOW RATE (CFM): 18,000  
RECIRCULATION RATE (GPM): 45  
MAKEUP WATER RATE (GPM): 4.5

MODEL NUMBER : HF-180  
STACK HEIGHT (FT):  
STACK DIAMETER (IN):  
STACK VELOCITY (FPM):  
DUCT MATERIAL :

PERMIT HISTORY

PERMIT NUMBER: N/A  
DATE EXPIRED :

PERMIT NUMBER:  
DATE EXPIRED :

PERMIT NUMBER:  
DATE EXPIRED :

SCRUBBER INFORMATION

HARRIS ID # : F51S05  
MANUFACTURER : HARRISON MODEL NUMBER : HF-180  
SERIAL NUMBER: N/A MATERIAL : POLYPRO  
DESCRIPTION : HORIZONTAL CROSS-FLOW, PLASTIC SADDLE PACKING. LIQUID  
DISTRIBUTION THROUGH MAIN HEADER. NO SPRAY NOZZLES  
DWG HPS-217-C 11/21/83

DESIGN DATA

VOLUME FLOW RATE (CFM): 18,000 PRESSURE DROP (IN):  
RECIRCULATION RATE (GPM): 45 MAKE UP RATE (GPM): 4.5

ACTUAL DATA

VOLUME FLOW RATE (CFM): PRESSURE DROP (IN): N/E DATE: 6/3/87  
RECIRCULATION RATE (GPM): N/E MAKE UP RATE (GPM): N/E DATE: "

RECIRCULATION PUMP INFORMATION

MANUFACTURER : GENERAL ELECT. MODEL NUMBER : 5K33KN42  
SERIAL NUMBER: AYD/ HP : 1/3 RPM : 1725  
BRKR LOCATION: FED FROM MCC : #5

FAN INFORMATION

HARRIS ID # :  
MANUFACTURER : TRANE MODEL NUMBER: 81 TYPE AF  
SERIAL NUMBER: K3H244576 MATERIAL :  
DESCRIPTION : SIZE 44, CLASS I

DESIGN DATA

VOLUME FLOW RATE (CFM): STATIC PRESS (IN):

ACTUAL DATA

VOLUME FLOW RATE (CFM): SPEED (RPM): DATE:  
STATIC PRESS (IN): DATE:

FAN MOTOR INFORMATION

MANUFACTURER : US ELECTRICAL MODEL NUMBER :  
SERIAL NUMBER: HP : 30 RPM : 1760  
BRKR LOCATION: FED FROM MCC :

Best Available Copy

# Harrison Plastic Packed Scrubbers

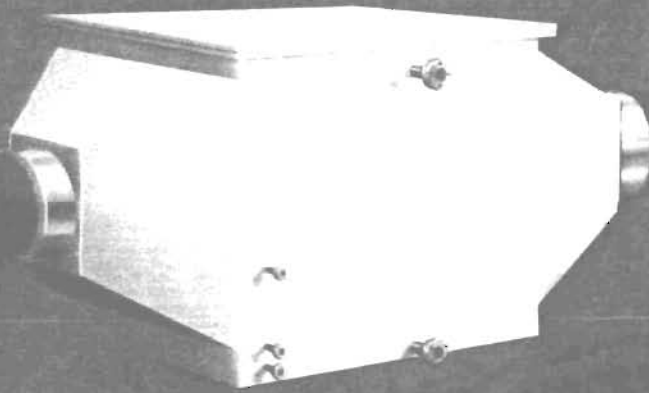

## THE HARRISON SYSTEM

Harrison is a prime designer and producer of complete plastic exhaust systems, custom engineered scrubbing systems, as well as duct and fittings, tanks, and hoods. As a result of this capability and experience, design and manufacture of standard, pre-engineered fume scrubbers is a natural extension.

### MATERIALS

Self-supporting or fiberglass armored PVC and Polypropylene, fiberglass armored Kynar, and solid fiberglass construction offers a wide range of resistance to acids, alkalis, solvents, and other corrosives at operating temperatures to approximately 250°F. Harrison systems do not use any metal in contact with the process stream.

### PRE-ENGINEERING

Pre-engineered design reduces cost by eliminating the necessity to re-invent each item ordered. It results in more reliable service thru improved workmanship achieved by repetitive production control, and speeds quotations and approval drawings because costs and designs are immediately available. In addition to significant savings in approval and order time, Harrison reduces delivery time by stocking scrubber components including packing, support grids, distributor plates, nozzles, duct reducers, and sheet stock.

### SCRUBBER CONFIGURATION

Most fume removal applications can be served by the two scrubber designs shown in this catalog. Vertical Counter Current style directs liquid down vertically, and unwanted fumes upward in the opposite direction. Horizontal Cross Flow unit directs liquid down vertically, but unwanted fumes are driven horizontally at 90° to the liquid. In both designs, liquid and fumes are inter-mixed in the packed bed section of the scrubber where fumes are removed by chemical reaction or water solubility. Scrubber shape does not affect performance. Horizontal design presents a low profile and is suitable where head room is limited. Verticals require more head room, but use only minimum floor space.

### SCRUBBER DESIGN AND OPERATION

Highest scrubber efficiency (volumetric % of contaminate removed) is obtained by having the proper amount of contact surface area (packing) wetted by sufficient liquid (recirculated liquid rate) for an optimum residence time (packing depth) to allow unwanted fumes to take a treacherous path thru the wetted packing to permit their maximum removal from the carrier air stream by chemical reaction or water solubility.

Air stream resistance encountered in the packing (static pressure loss) is a function of air velocity, cross-sectional packing area, and packing depth. Harrison scrubbers utilize proven packing depth to achieve efficiencies approaching 99+%, when operated within recommendations.

### LIQUID DISTRIBUTION AND MIST ELIMINATION

Simple liquid distribution is achieved thru a main header pipe feeding perforated laterals, without use of troublesome spray nozzles. Nozzles are subject to plugging, and produce a difficult-to-remove atomized mist carryover. In the Harrison design, any large droplets of liquid caught in the upward moving air stream are easily and efficiently removed by a short bed of dry packing located above the liquid distributor.

### STATIC PRESSURE LOSS

Use of high-surface-area, low-pressure-drop plastic saddles in a balanced design result in low static pressure loss of only 0.4 inches H<sub>2</sub>O (w.g.) per foot of packed depth in Vertical Counter Current scrubbers, and 0.33 in Horizontal Cross Flow units. At the same time, sufficient irrigation rates constantly keep saddles clear of potential sludge buildup. Thereby, continuous, non-clogging operation at a proper rate of intermixing turbulence between liquid and fumes is achieved for 99+% efficiency.

### LIQUID SUMP OPERATION

Harrison scrubbers employ an integral liquid recirculating sump which reduces amount of liquid consumption required by 90 to 95% in most applications. Therefore, considerably less effluent must be handled and treated. The sump reservoir is contained within the scrubber itself. Harrison recommends optimum rate of effluent removal. When effluent is acidic only, additional liquid conservation can be obtained with either scrubber design with the simple optional recovery system shown with the vertical scrubber drawing on page 4. If central treating facilities exist, no sump, recirculation, or independent recovery is needed. In this case, treated liquid would be directed over the packing in a single pass, then treated, then returned to the scrubber, etc. In both instances where effluent is treated, liquid consumption would be reduced to only that amount lost by evaporation.

# Harrison

Box 184 Aurora Ohio 44202/216-562-9545

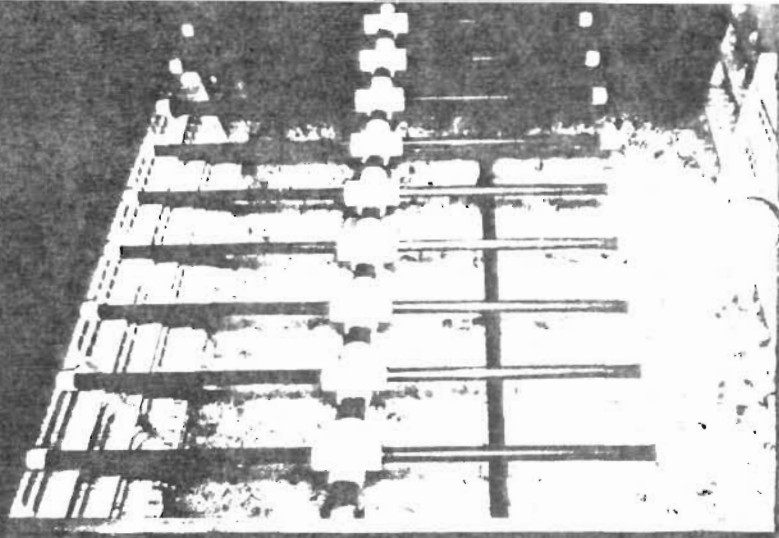

**TOP VIEW**



**SIDE VIEW (CUT-A-WAY)**

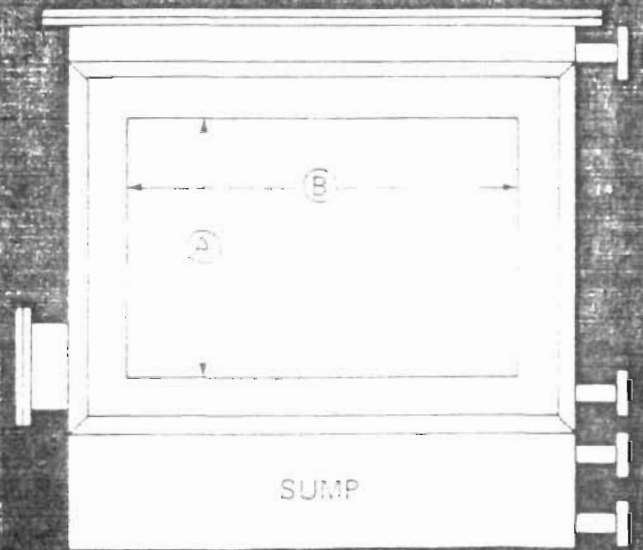

**INLET SIDE VIEW**



# HORIZONTAL CROSS-FLOW

Model	CFM	Inlet & Outlet A x B In.	Length L Fl.	Width W In.	C In.	D In.	E In.	F In.	G In.	Sump Capacity Gal.	Rec. Liquid GPM	Overall Height In.	Ship* Wt. Lbs.	Operating Wt. Lbs.
HF-8	800	11x11	6	17	¾	1	1	1¼	1	58	17	35	182	646
HF-12	1,200	14x14	6	20	¾	1	1	1¼	1	69	21	38	224	781
HF-17	1,700	18x18	6	24	¾	1	1	1½	1¼	82	24	42	275	926
HF-21	2,100	21x21	6	27	¾	1	1	1½	1¼	92	28	45	316	1028
HF-25	2,500	24x24	6	30	¾	1½	1½	1½	1¼	102	32	48	357	1166
HF-31	3,100	27x27	6	33	¾	1½	1½	1½	1¼	113	35	51	419	1313
HF-37	3,700	30x30	6	36	¾	1½	1½	1½	1¼	125	39	54	481	1445
HF-45	4,500	33x33	6	39	¾	1½	1½	1½	1¼	134	42	57	563	1669
HF-50	5,000	36x36	6	42	¾	1½	1½	1½	1¼	144	45	5.0 ft.	615	1733
HF-57	6,700	36x36	6	48	1	2	2	1½	1¼	165	51	5.5	690	1980
HF-85	8,500	42x42	6	54	1	2	2	2	1½	186	56	6.0	824	2276
HF-105	10,300	48x48	6	60	1	2	2	2	1½	206	60	6.5	1035	2639
HF-125	12,000	54x54	6	66	1	2	2	2	1½	228	63	7.0	1242	2990
HF-150	15,000	60x60	6	72	1	2	2	2½	2	247	74	7.5	1545	3460
HF-176	17,600	66x66	6	78	1	2	2	2½	2	268	89	8.0	1751	3883
HF-190	19,000	66x72	6	84	1	2	2	2½	2	290	86	8.0	1857	4161
HF-220	22,000	66x84	6	96	1	2	2	2½	2	319	90	8.0	1966	4770
HF-245	24,500	66x96	6	108	1½	3	2	3	3	371	112	8.0	2624	6376
HF-273	27,000	66x108	6	120	1½	3	2	3	3	412	123	8.0	2835	6980
HF-300	30,000	66x120	6	132	1½	3	2	3	3	454	136	8.0	3040	7684
HF-327	32,700	66x132	6	144	1½	3	2	3	3	495	147	8.0	3450	7388

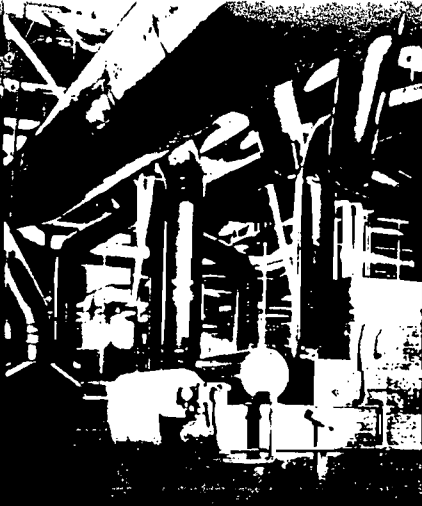

MEET YOUR  
**POLLUTION  
 CONTROL**  
 REQUIREMENTS  
 WITH THE LEADER IN  
**PVC** FABRICATIONS



# Duall

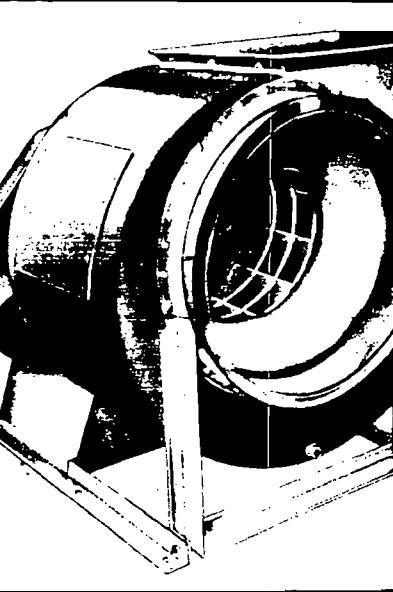

CONTROLLED ENVIRONMENTS FOR INDUSTRY  
 P. O. BOX 10428 — 904/396-7733  
 JACKSONVILLE, FLORIDA 32247-0428  
 DANIEL J. KLOS

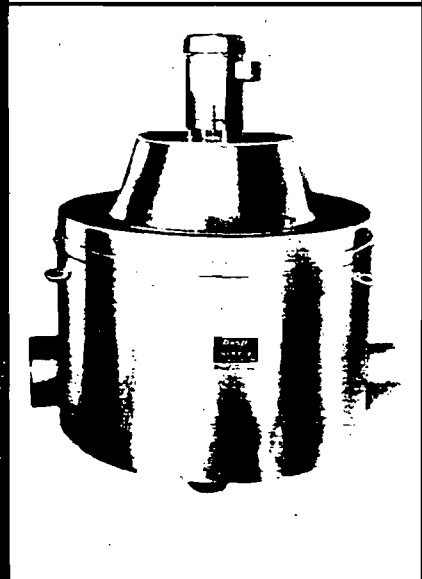

**PVC** CONSTRUCTED  
 FUME SCRUBBERS  
 CENTRIFUGAL FANS  
 DUCTING and HOODS  
 OIL MIST COLLECTORS  
 COMPLETE SYSTEMS

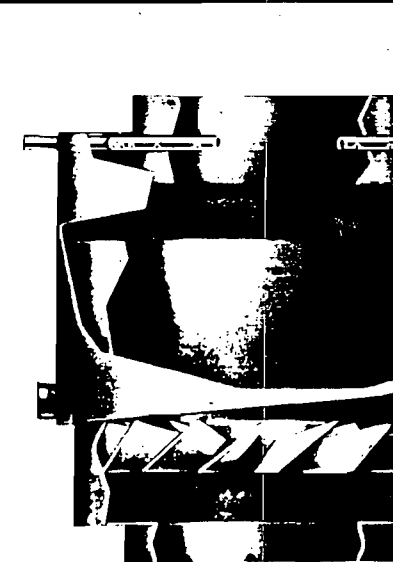

**Duall**  
 INDUSTRIES, INC.

700 S. McMillan Street • Owosso, Michigan 48867  
 Phone (517) 725-8184 • Telex 228-532

P. O. Box 1000 • 102 Hillside Drive  
 Forest City, N.C. 28043 • (704) 245-8725

# Duall

## Fume Scrubbers in 6 Types

### F-101 SERIES

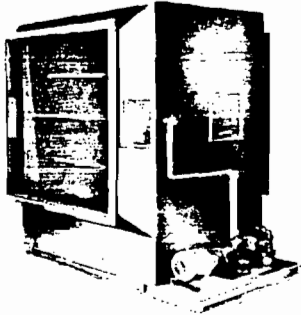

Single Pack

Double Pack

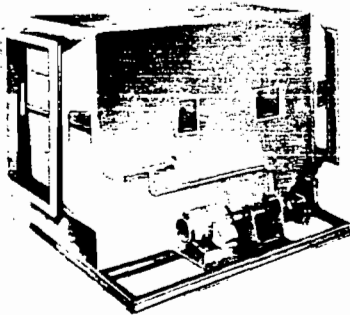

### FW-300 SERIES

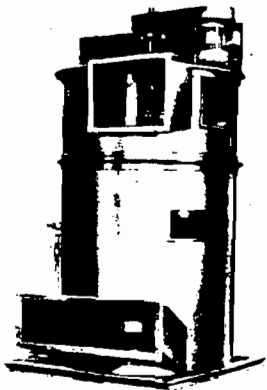

Single Pack

Double Pack



### PT-500 SERIES

Single Pack



Double Pack

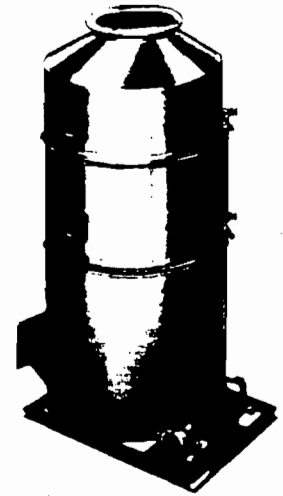

Duall Single Pack (four Stage) Fume Scrubbers solve most industrial air pollution problems. They are especially effective on water soluble fumes and odors, or with pH control on many low soluble contaminants.

Some typical proven applications are:

- Acid fumes.
- Plating fumes.
- Cleaning fumes.
- Lab hood fumes.
- Anodizing fumes.
- Pickling fumes.
- Rust-proofing fumes.
- Die-casting fumes.
- Water soluble odors.

Duall Single Pack Fume Scrubbers incorporate these advantages:

- Low cost.
- Low maintenance.
- Low water consumption.
- Low static pressure drop.
- 100% corrosion resistant.

Duall Double Pack (six stage) Fume Scrubbers offer the broadest range of answers to industrial air pollution problems. By double scrubbing the air these scrubbers provide maximum efficiency on tough fumes and odors which can not be completely absorbed in a single pack type scrubber.

Duall's Double Pack Scrubbers have proven effective on the following typical applications:

- Bright dip fumes.
- Strip tank fumes.
- Etching fumes.
- Most low solubility fumes and odors.

Our Double Pack Fume Scrubbers offer all the advantages of the Single Pack units as well as the broadest range of applications.

All Duall Fume Scrubbers can be modified for custom installation with multiple packs or extended depth packs. Multiple modular units are available for capacities larger than standard.

*See page 6 for complete specs and performance data.*





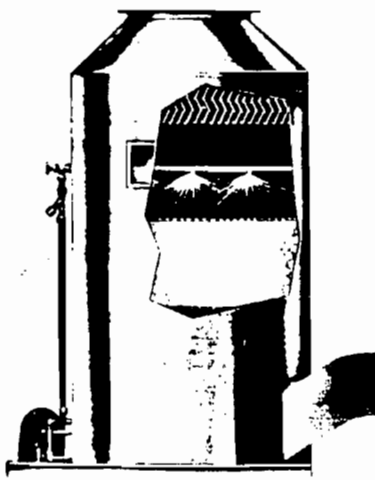
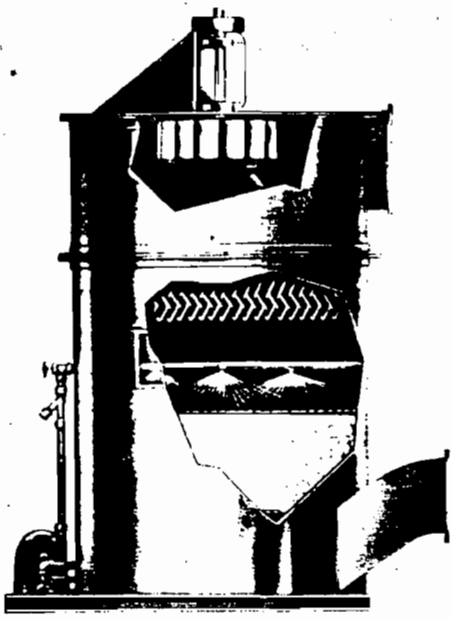

# Duall INDUSTRIES

**PVC** Constructed, 100% Corrosion Free

## FUME SCRUBBERS

### FW-300 Vertical Pack with Blower

500 TO 12,000 C.F.M. . . plus multiple installations

This packed tower type scrubber is not only a space saver, it's also a true economy model. It incorporates a built-in rugged fan with convenient exterior, belt driven, TEFCBB motor. During installation, the horizontal air discharge can be swivelled 360° before sealing into permanent position. Efficiency is equal to the F-101 and the PT-500. Compactness and versatility make it an unusually popular model. This FW-300 saves three ways . . . in initial cost, installation, and in space. Also available with double pack.

### F-101 Horizontal Single Filter Pack

500 TO OVER 60,000 C.F.M. . . plus multiple installations

Being our most popular scrubber design, this compact 100% corrosion resistant P.V.C. unit has proven its efficiency in 46 states. The Duall F-101 incorporates high efficiency, low maintenance filter media and the open orifice type spray nozzles, for the assurance of a thoroughly saturated collection chamber. Our mist eliminator outlet section gives four air direction changes to properly remove the entrained moisture. Where a horizontal installation is preferred, the F-101 should be your choice.

### F-101-D Horizontal Double Filter Pack

500 TO OVER 60,000 C.F.M. . . plus multiple installations

An extra heavy duty scrubber for real "tuffies". It incorporates two filter packs with two sets of sprays for more thorough scrubbing . . . plus an effective mist eliminator at the air outlet. Serious concentrations of rough fumes, such as nitric, hydrofluoric, and hydrochloric acid are double scrubbed through six stages for maximum efficiency. For such problems in your plant, use this high efficiency fume scrubber, at only a small increase in price.

### PT-500 Vertical Pack

500 TO OVER 30,000 C.F.M. . . plus multiple installations

The upright PT-500 is the space saver. This scrubber is a vertical packed tower type designed to fit into restricted spaces where floor space is at a premium. Its efficiency is equal to the F-101, and also 100% corrosion-free. Air flow is up through a thoroughly water saturated bed of filter media. The mist eliminator pack near the top outlet assures properly dried air. If space is your problem, take a good look at the PT-500. Also available with double pack.

# Duall

INDUSTRIES, INC.

770 South McMillan St.  
Owosso, Michigan 48867  
Telephone (517) 725-8184  
Telex 228-532

P.O. Box 1000  
Forest City N.C. 28043  
Telephone (704) 243-372

# Duall FUME SCRUBBERS

## SPECIFICATIONS and PERFORMANCE DATA

### DESCRIPTIONS

**F-101.** Horizontal (cross-flow), four stage, wet scrubber. This model has maximum efficiency on water soluble contaminants and odors, but is also effective on low soluble contaminants with the use of chemical neutralizers.

**F-101D.** Horizontal (cross-flow), six stage, wet scrubber. The F-101D is especially designed for use on stubborn low solubility contaminants or where extremely high scrubbing efficiency is required on normal contaminants.

**FW-300.** Vertical (counter-flow), four stage, wet scrubber with integral blower. Efficiency is equal to the F-101.

**FW-300D.** Vertical (counter-flow), six stage, wet scrubber with integral blower. Efficiency is equal to the F-101D.

**PT-500.** Vertical (counter-flow), four stage, wet scrubber. Efficiency is equal to the F-101.

**PT-500D.** Vertical (counter-flow), six stage, wet scrubber. Efficiency is equal to the F-101D.

All Duall Fume Scrubbers are constructed of P.V.C. and Polypropylene corrosion resistant materials and include a rugged coated steel base with lifting lugs. All above units are available with extended depth packing.

### SCRUBBING PRINCIPLES

Contaminant removal is accomplished by first slowing the fumes to a velocity below 500 fpm and then passing the fumes through two scrubbing stages in the single pack models and four stages in the double pack types. The fumes first pass through a water spray or curtain during which a percentage of the larger contaminant particles drop out and the remaining fumes are saturated. The second stage consists of a 12" deep pack of polypropylene high surface, non-clogging, spherical plate packing media\* which is continuously wetted by the spray nozzles. The saturated fumes are impinged upon the packing and the contaminants are absorbed and carried away in the wash water. The first and second stages are repeated in the double pack fume scrubbers.

\*Several types of alternate packing media are available on request.

### MIST ELIMINATION

After passing through the scrubbing sections, the air is moisture laden and must pass through a two stage gravity mist eliminator section. This final stage of P.V.C. eliminator blades provides four 30° changes in direction and eliminates entrained water.

### WATER SUPPLY

All Duall Fume Scrubbers may be supplied with water either directly from your supply or from an integral or remote recirculation system supplied with the scrubber. It is generally recommended that a recirculation system be used to conserve water except on very low cfm units. **The actual fresh water consumption on the single pack series with recirculation is only 0.05 to 0.15 gpm/1000 cfm depending on the contaminant involved.** On the double pack models, water consumption ranges from 0.1 to 0.3 gpm/1000 cfm. This represents 5% of the water being recirculated. Duall scrubbers are self-draining and may be installed out-doors in sub-zero conditons without freeze-up. If these conditions exist, a remote recirculation system should be specified for placement in a heated area.

All Duall Scrubbers come complete with fittings for the addition of chemical neutralizers, if required. A complete chemical metering and pumping system is available upon request.

### MATERIALS

Every Duall Fume Scrubber is shipped complete with an integral coated steel base. No special mounting is required. Simply connect the duct, the water and power supply, and the unit is ready for operation. Complete installation and operating instructions are supplied with all Duall Scrubbers.

### PRESSURE DROP

The following pressure drops are applicable for Scrubbers operated at design CFM:

<b>F-101</b>	2.0" w.g.	<b>FW-300D</b>	3.0" w.g.
<b>F-101D</b>	3.0" w.g.	<b>PT-500</b>	2.0" w.g.
<b>FW-300</b>	2.0" w.g.	<b>PT-500D</b>	3.0" w.g.

On the FW-300 series, the blower is designed for 2.0" external static pressure.

### FW-300 BLOWER SECTION

The top section of the FW-300 Fume Scrubber consists of a Duall P.V.C. centrifugal blower complete with motor and OSHA belt guard and shaft cover. The blower section may be rotated through 360° to obtain any desired angle between scrubber inlet and blower outlet. This blower section is same low maintenance, guaranteed corrosion resistant blower described in Duall Brochure No. CI-131, and NH-151.

### MAINTENANCE

All Duall Fume Scrubbers incorporate low maintenance components from front to back, including the packing, plumbing system and eliminators. Quick opening inspection doors are at all critical points.

**DUALL FUME SCRUBBERS**  
Typical Average Fume Removal Efficiencies

MODELS ▶  CONTAMINATES ▼	Single Pack Series: F-101 PT-500 FW-300	Double Pack Series: F-101D PT-500D FW-300D	Single Pack Series:  with added Chemical Neutralizer (pH Control)	Double Pack Series:
	Acetic Acid	95-98	98-99	—
Alkaline Cleaners	96-99	98-99	—	—
Aluminum Bright Dip*	80-85	85-90	—	—
Anodizing	96-99	98-99	—	—
Aqua Regia	80-85	85-90	85-90	90-95
Boric Acid	85-90	90-95	—	—
Caustic Cleaners	98-99	99	—	—
Caustic Soda	98-99	99	—	—
Chlorine	80-85	85-90	85-90	90-95
Chromic Acid	98-99	99	—	—
Copper Chloride	75-80	80-85	85-90	90-95
Cyanide Solutions	98-99	99	—	—
Ferric Chloride	80-85	83-88	—	—
Ferric Nitrate	96-98	98-99	—	—
Ferrous Chloride	90-95	95-98	—	—
Ferrous Sulfate	95-97	96-98	—	—
Fluosilicic Acid	95-98	98-99	—	—
Hydrochloric Acid	80-85	85-90	90-95	95-98
Hydrogen Cyanide	85-90	90-95	—	—
Hydrofluoric Acid	90-93	95-98	—	—
Hydrofluosilicic Acid	95-98	98-99	—	—
Hydrogen Peroxide	90-95	95-99	—	—
Hydrogen Sulfide	70-75	75-80	85-90	95-98
Nickel Chloride	80-85	85-90	90-95	95-98
Nickel Sulfate	80-85	85-90	90-95	95-98
Nitric Acid	75-80	85-90	—	—
Nitrogen Dioxide (NO <sub>2</sub> )	45-50	50-60	65-70	70-75
Nitric — HF Acid	75-80	85-90	—	—
Perchloric Acid	95-98	96-99	—	—
Phosphoric Acid	96-99	98-99	—	—
Potassium Dichromate	96-98	98-99	—	—
Selenium Sulfide	96-98	98-99	—	—
Sodium Chloride	96-98	98-99	—	—
Sodium Fluoride	90-95	95-98	—	—
Sodium Glutamate	96-98	98-99	—	—
Sodium Hydroxide	98-99	99	—	—
Sulfur Dioxide	70-75	75-80	80-85	85-90
Sulfuric Acid	96-98	98-99	—	—
Tin Chlorides	75-80	80-85	85-90	90-95
Zinc Chloride	75-80	80-85	—	—
Zinc Nitrate	96-98	98-99	—	—
Zinc Sulfate	96-98	98-99	—	—

\* These efficiencies are for the combined nitric and phosphoric fume. The efficiency for the NO<sub>2</sub> portion of the fume only will be as listed above.

• The above efficiencies are intended as guide representing average values. Specific combinations and concentrations of fumes may result in a significant variation from the above.

# TECHNICAL BULLETIN

*Duall  
Industries*

No. 121-9

## DUALL SCRUBBERS INSTALLATION, OPERATION & MAINTENANCE INSTRUCTIONS

Date 3/1/80

Superseding Bulletin 4/24/79

Page 1

### 1. AIR FLOW

Units are normally designed to be on the suction side of the fan. Air flow through units must be in the direction indicated. Too large a deviation from the design flow (CFM) will affect the efficiency of the scrubber.

### 2. SUPPORTING THE UNIT

The scrubber rests on a steel channel base making the unit self-supporting. This steel base may be suspended from overhead structure or rest on any media suitable to support the unit's weight.

### 3. CONNECTION TO VENTILATION DUCT

To eliminate the possibility of water running down the duct, there should be a minimum of 4 ft. of horizontal duct before the scrubber transition. This should be sloped slightly towards the bottom of the scrubber. The flanges should be field drilled on approximately 4"-5" centers. A soft foam type chemically compatible gasket material is recommended between the scrubber flange and the duct flange.

### 4. ELECTRICAL CONNECTION

Proper electrical connection complying with local codes should be made to the pump motor.

### 5. UNITS WITH INTERNAL RECIRCULATION SYSTEM

Units should be installed in heated areas or protected from freezing. Fresh water must be supplied by connecting the supply line to the flowmeter provided. This flowmeter is mounted on the side of the scrubber. The make-up water line should be valved to provide a maximum of 5% of the recirculation rate as shown on the side of the scrubber. The scrubber drain is connected to customer's waste drain line. If this line must go to a sump, it must be submerged 6"-8" below the lowest expected level, or a plumber's "P" trap should be installed. This will prevent air from flowing into the drain line and interfering with proper drainage of the scrubber. Liquid build-up in the scrubber can interfere seriously with the proper operation of the scrubber.

BEFORE START-UP, INSPECT THE INSIDE OF THE SCRUBBER AND REMOVE ANY FOREIGN MATERIAL FROM THE UNIT. SHUT THE WASTE DRAIN VALVE AND FILL THE SCRUBBER BASE SUMP WITH WATER UNTIL WATER FLOWS FROM THE OVERFLOW DRAIN. WATER IS INTRODUCED THRU THE FLOWMETER AND CAN ALSO BE INTRODUCED BY A HOSE PLACED THRU THE INSPECTION DOORS. When the water reaches the overflow level, the pump and fan may be started.

6. UNITS DESIGNED WITH REMOTE RECIRCULATION TANK AND PUMP

All units designed for remote recirculation require a separate recirculation tank with an adequately sized overflow and waste drain. The use of the remote recirculation tank will permit the installation of self-draining scrubber outside the building and the recirculation tank inside the building. The scrubber must be elevated for proper drain return to the recirculation tank. The scrubber drain pipe must be submerged 6" to 8" below the lowest expected liquid level in the tank and on the opposite side from the pump suction. The pipe end should be cut on a 60° angle with the long opening facing the tank side. For information on start-up and make-up water, please refer to Section 5 above. Make-up water may be introduced into the recirculation tank through the separate flowmeter provided for installation into water line.

7. PUMPS

Pumps should be operated in accordance with the enclosed manufacturer's instructions. Pumps with mechanical seals should be given particularly special attention to assure operation as directed. Pump motor should be electrically bumped to check for proper rotation. Motors and pumps are aligned and checked for proper operation before shipment. Customer is cautioned that misalignment may occur during shipment. Check for misalignment by manually rotating the shaft while observing coupling alignment using a straight edge or a dial indicator. Pumps provided with a packing gland are pre-adjusted to drip approximately 30 drops per minute. Drain fittings are provided on the pump or on a collection pan which should be plumbed to the waste drain. Pump motor should be interlocked with fan to provide approximately two (2) minutes pump operation before fan may be started. Pumps should not be started until the scrubber base or remote recirculation tank are filled to the overflow level. During the early break-in period, the pump packing gland should be checked for proper weeping. If incorrect, check pump manufacturer's instructions for correction procedure.

8. CHEMICAL ADDITIONS

In some cases, liquid caustic (sodium hydroxide solution) or an acid solution may be metered into the recirculation system to increase scrubber efficiency. A threaded coupling is provided in the side of the self-contained recirculation scrubbers for introduction of this chemical addition. Chemical addition for scrubbers provided with remote recirculation tanks is made by adding the solution to the recirculation tank. When using solid caustic, care should be taken in mixing to assure that no solid material is pumped into the scrubber or recirculation tank which may cause a build-up. The pH of the recirculation tank should be maintained in a range that will achieve the desired scrubber efficiency while preventing the appearance of a build-up on the packing. A pH control package may be purchased from Duall to provide a chemical feed pump and pH control to maintain the recirculation solution in the satisfactory range.

# TECHNICAL BULLETIN

*Duall  
Industries*

No. 121-9

## DUALL SCRUBBERS INSTALLATION, OPERATION & MAINTENANCE INSTRUCTIONS

Date 3/1/80

Superseding Bulletin 4/24/79

Page 3

### 9. PERIODIC MAINTENANCE SCHEDULE

Inspection doors are provided in all scrubber units for periodic inspection. While it is not expected that maintenance will be required, periodic inspection on a monthly basis is suggested. This inspection should include the following:

- A. Check spray nozzles with the pump and fan in operation. All nozzles should produce a full 360° spray pattern. If any nozzles are found to be spraying incorrectly, the pump should be stopped, the header pipe removed, and each nozzle cleaned individually. When the cleaned header system has been replaced, the pump may be re-started.
- B. Check the face of the scrubber and the spray nozzles for any indication of a build-up of solids. If a surface build-up has occurred, it may be removed by spraying the pack with high pressure water, by chemical treatment of the scrubbing solution to dissolve the scale, or by manually removing the surface build-up. An analysis of the material build-up can be made to determine its nature. A dissolving additive, compatible with P.V.C. then could be added to the recycling reservoir for closed loop cleaning. During this type of cleaning, the drain and make-up water valves should be closed. During this operation, someone should frequently check the operation of the nozzles, and solution level to prevent pump damage. Prior to putting the system back in service, the cleaning solution should be drained and the scrubber refilled with fresh water. Steam should not be used to clean the scrubber.
- C. Check the water level in the scrubber. While the scrubber is in operation, it should maintain a solution of approximately 3"-6" in the bottom of the scrubber on a remote recirculation system and to the overflow on others.

CFM	0.5	1	2	3	4	5	6	8	10	12	14	16	18	20	22	24	26	28	30	35	40	45	50	55	60
A	18	22	28	32	37	41	45	52	58	64	69	74	81	88	97	104	112	123	135	157	179	202	224	247	269
B	10	14	20	24	29	33	37	44	46	52	57	62	65	61	61	61	61	61	61	61	61	61	61	61	61
C	10	14	20	24	29	33	37	44	46	52	57	62	69	72	81	88	96	107	119	141	163	186	208	231	253
D	49	50	50	51	52	52	53	54	59	60	60	61	61	66	66	66	66	66	66	66	66	66	66	66	66
E	30	34	40	44	49	53	58	65	71	77	82	87	91	91	91	91	91	91	91	91	91	91	91	91	91
F	3 1/2	3 1/2	3 1/2	3 1/2	3 1/2	3 1/2	4 1/2	4 1/2	4 1/2	4 1/2	4 1/2	4 1/2	5 1/2	5 1/2	5 1/2	5 1/2	5 1/2	5 1/2	5 1/2	5 1/2	5 1/2	5 1/2	5 1/2	5 1/2	5 1/2
G	1 1/2	1 1/2	1 1/2	1 1/2	1 1/2	1 1/2	2	2	2	2	2	2	2	2	2	2	2	2	2	2	2	2	2	2	2
K	2	2	2	2	2	2	3	3	3	3	3	3	4	4	4	4	4	4	4	4	4	4	4	4	4
Q	37	38	38	39	40	40	41	42	43	44	44	45	45	46	46	46	46	46	46	46	46	46	46	46	46
R	31	35	41	45	50	54	58	65	71	77	82	87	94	101	110	117	125	136	148	170	192	215	237	260	282
U	21	23	26	28	30 1/2	32 1/2	35 1/2	39	42	45	47 1/2	50	52 1/2	52 1/2	52 1/2	52 1/2	52 1/2	52 1/2	52 1/2	52 1/2	52 1/2	52 1/2	52 1/2	52 1/2	52 1/2
OVERFLOW	1 1/2	1 1/2	1 1/2	1 1/2	1 1/2	1 1/2	1 1/2	1 1/2	1 1/2	1 1/2	1 1/2	1 1/2	1 1/2	1 1/2	1 1/2	1 1/2	1 1/2	1 1/2	1 1/2	1 1/2	1 1/2	1 1/2	1 1/2	1 1/2	1 1/2
PUMP SUCTION	1	1	1	1	1	1	1	1 1/4	1 1/4	1 1/2	1 1/2	2	2	2	2	2	3	3	3	3	3	3	3	3	3
PUMP DISCHARGE	3/4	3/4	3/4	3/4	3/4	3/4	1	1	1	1 1/4	1 1/4	1 1/4	1 1/2	1 1/2	1 1/2	2	2	2	2	2	3	3	3	3	3
LIQUID RATE GPM	15	3	6	9	12	15	18	24	30	36	42	48	54	60	66	72	78	84	90	105	120	135	150	165	180

NOTE: CFM IN THOUSANDS

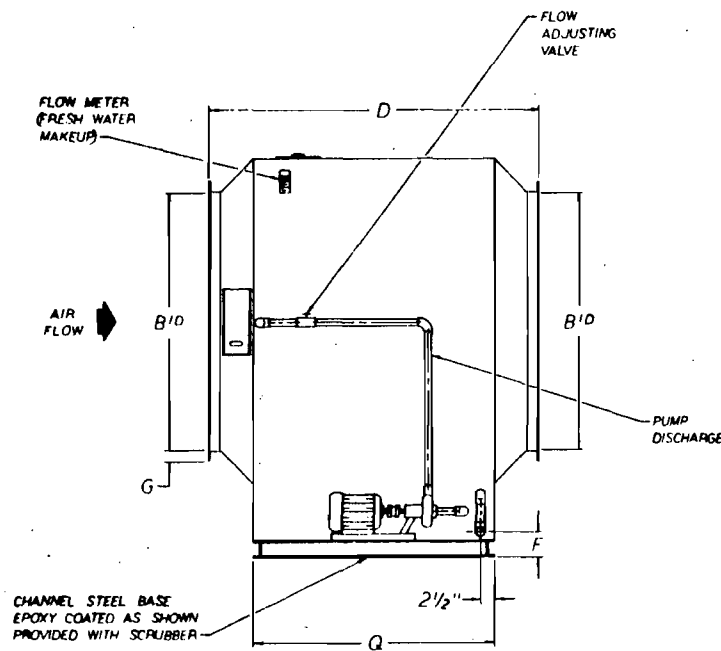
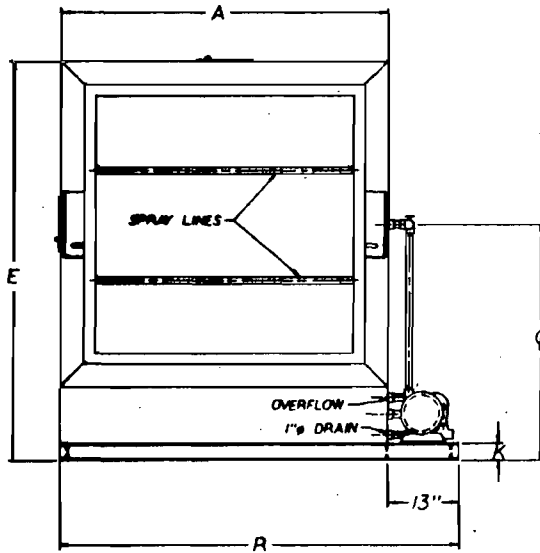
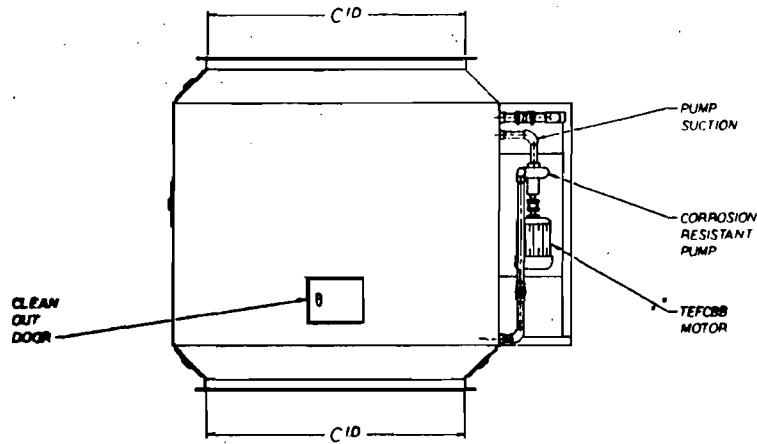

F-101 FUME SCRUBBER	
WITH SELF-CONTAINED RECIRCULATION	
DUAL INDUSTRIES, INC. OWOSSO, MI.	
DATE	DUAL JOB NO.
PURCHASER	
PURCHASER PO NO.	
PURCHASER LOCATION	
JOB NAME	
JOB LOCATION	
SPECIFICATION NO.	ITEM NO.
CAPACITY	CFM
PRESSURE DROP	WG.
LIQUID RECIRCULATION RATE	GPM
LIQUID PRESSURE	TDM
MAKEUP RATE	GPM
RECIRCULATION PUMP	
PUMP CAPACITY	GPM
PUMP HP	TDM
PUMP VOLTAGE	V PH. Hz.

TAG:

D-101-1016

F-101 FUME SCRUBBER			
WITH SELF-CONTAINED RECIRCULATION			
SCALE	SHEET	OF	DRAWING
DUAL INDUSTRIES, Inc., Owosso, Mich.	DATE	BY	CHKD.

CFM	0.5	1	2	3	4	5	6	8	10	12	14	16	18	20	22	24	26	28	30	35	40	45	50	55	60
A	18	22	28	32	37	41	45	52	58	64	69	74	81	88	97	104	112	123	135	157	179	202	224	247	269
B/D	10	14	20	24	29	33	37	44	46	52	57	62	65	61	61	61	61	61	61	61	61	61	61	61	61
C/D	10	14	20	24	29	33	37	44	46	52	57	62	69	72	81	88	96	107	119	141	163	186	208	231	253
D	49	50	50	51	52	52	53	54	59	60	60	61	61	66	66	66	66	66	66	66	66	66	66	66	66
E	30	34	40	44	49	53	58	65	71	77	82	87	91	91	91	91	91	91	91	91	91	91	91	91	91
F	3 1/2	3 1/2	3 1/2	3 1/2	3 1/2	3 1/2	4 1/2	4 1/2	4 1/2	4 1/2	4 1/2	4 1/2	5 1/2	5 1/2	5 1/2	5 1/2	5 1/2	5 1/2	5 1/2	5 1/2	5 1/2	5 1/2	5 1/2	5 1/2	5 1/2
G	1 1/2	1 1/2	1 1/2	1 1/2	1 1/2	1 1/2	2	2	2	2	2	2	2	2	2	2	2	2	2	2	2	2	2	2	2
H	2	2	2	2	2	2	3	3	3	3	3	3	4	4	4	4	4	4	4	4	4	4	4	4	4
I	37	38	38	39	40	40	41	42	43	44	44	45	45	46	46	46	46	46	46	46	46	46	46	46	46
J	18	22	28	32	37	41	45	52	58	64	69	74	81	88	97	104	112	123	135	157	179	202	224	247	269
U/DIA	15 1/2	15 1/2	22 1/2	22 1/2	22 1/2	22 1/2	30	30	30	30	30	30	30	30	30	36	36	36	36	36	36	36	36	36	36
V	42	42	42	42	42	42	42	42	42	42	42	54	54	54	54	54	56	56	56	56	56	56	56	56	56
W	21	23	26	28	30 1/2	32 1/2	35 1/2	39	42	45	47 1/2	50	52 1/2	52 1/2	52 1/2	52 1/2	52 1/2	52 1/2	52 1/2	52 1/2	52 1/2	52 1/2	52 1/2	52 1/2	
OVERFLOW DRAIN PUMP SUCTION	1 1/2	1 1/2	1 1/2	2	2	2	2	2	3	3	3	3	3	3	4	4	4	4	4	4	4	4	4	4	4
PUMP DISCHARGE LIQUID RATE GPM	1	1	1	1	1	1	1 1/4	1 1/4	1 1/2	1 1/2	1 1/2	2	2	2	2	2	2	2	2	2	2	2	2	2	2

NOTE: CFM IN THOUSANDS

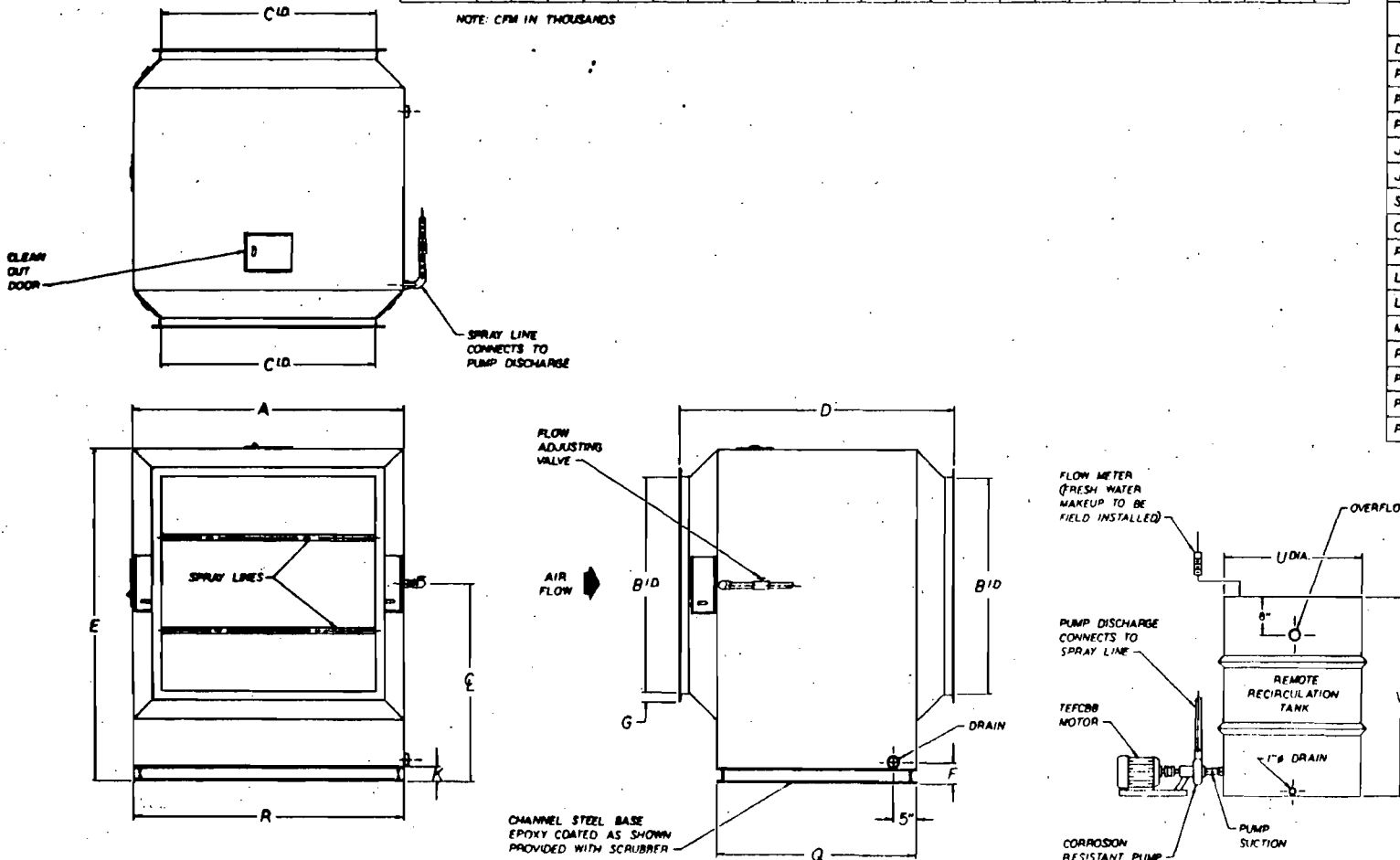

D-101-1017

F-101 FUME SCRUBBER				DESIGN D.I.
WITH REMOTE RECIRCULATION				DESIGN J.P.
SCALE	SHEET NO.	DATE 1-28-81	REVISED	REV. NO.
DUAL INDUSTRIES Inc. Owosso, MI.				REV. NO.

**F-101 FUME SCRUBBER**  
WITH REMOTE RECIRCULATION

DUAL INDUSTRIES, INC. OWOSSO, MI.

DATE	DUAL JOB NO.		
PURCHASER			
PURCHASER P.O. NO.			
PURCHASER LOCATION			
JOB NAME			
JOB LOCATION			
SPECIFICATION NO.	ITEM NO.		
CAPACITY	CFM		
PRESSURE DROP	W.G.		
LIQUID RECIRCULATION RATE	GPM		
LIQUID PRESSURE	TDM		
MAKEUP RATE	GPM		
RECIRCULATION PUMP			
PUMP CAPACITY	GPM	TDM	
PUMP HP			
PUMP VOLTAGE	V	PH	NZ



**DUAL F-101 FUME SCRUBBER  
PARTS LIST**

NO:	PART
100	EPOXY COATED STEEL BASE
101	CORROSION RESISTANT PUMP
102	TEFCBB MOTOR _____ V. / PH. / _____ CY. _____ H.P. _____ R.P.M.
103	PUMP SUCTION COUPLING (P.V.C.)
104	OVERFLOW COUPLING (P.V.C.)
105	DRAIN VALVE (P.V.C.)
106	PUMP DISCHARGE LINE (P.V.C.)
107	FLANGE (P.V.C.)
108	CLEAR OR P.V.C. CLEANOUT DOORS
109	FLOW METER _____
110	ELIMINATOR SECTION (P.V.C.)
111	POLYPROPYLENE PACKING
113	SPRAY HEADER VALVE (P.V.C.)
114	SPRAY HEADER (P.V.C.)
115	SPRAY NOZZLES

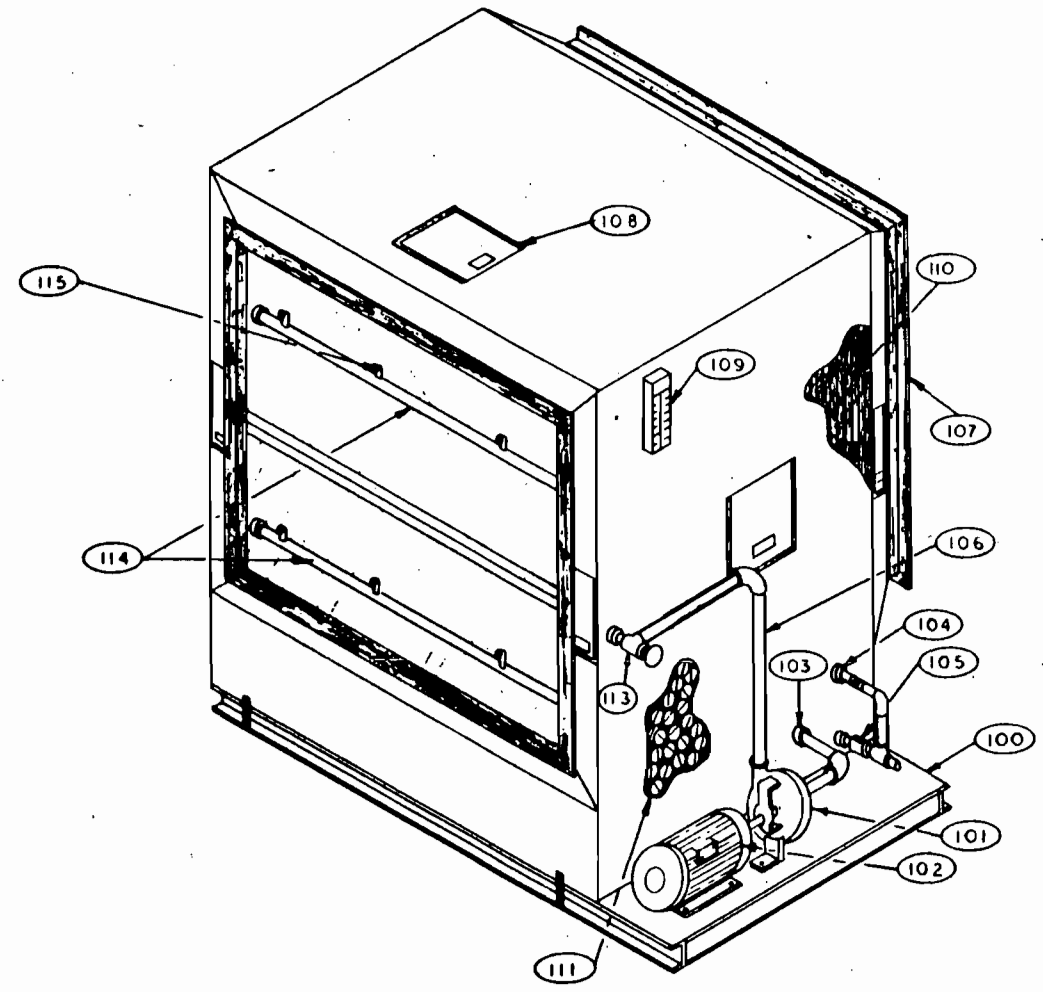

**PARTS LIST FOR  
REMOTE RECIRCULATION TANK**

116	OVERFLOW (P.V.C.)
117	REMOTE TANK (P.V.C.)
118	DRAIN (P.V.C.)
119	PUMP SUCTION COUPLING (P.V.C.)

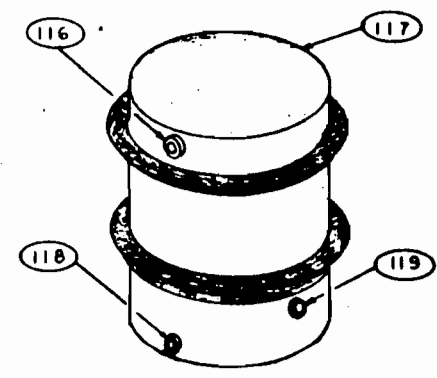

# The Tri-Mer Fume Washer

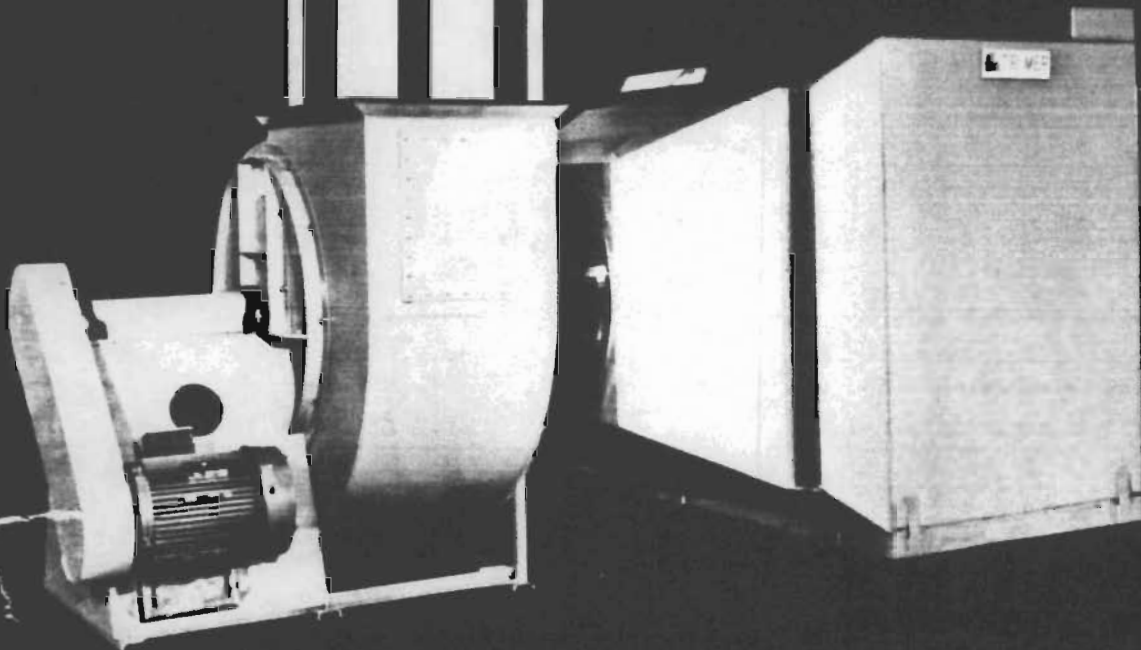
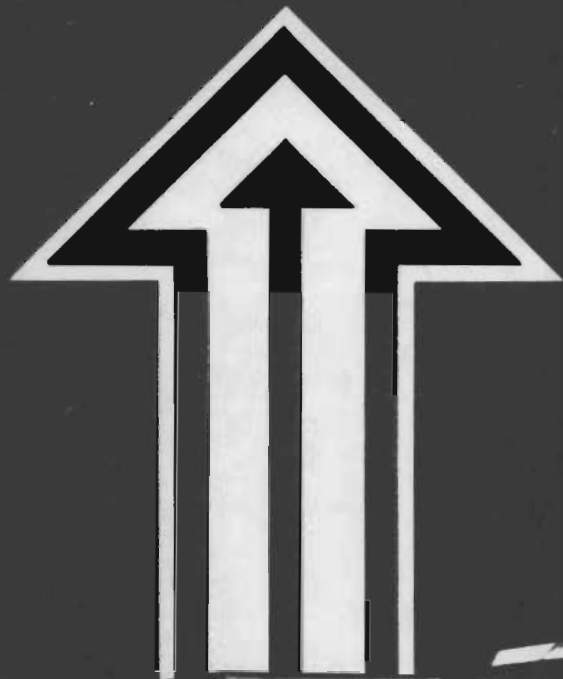

**Designers and Manufacturers of Corrosion Control Systems**

# Design Features of the Tri-Mer Fume Washer

TRI-MER fume washers offer an efficient economically packaged solution to your corrosive fume problems. Couple this unit to a TRI-MER all PVC fan, or use your existing fan, and you're ready for operation. A simple inexpensive installation.

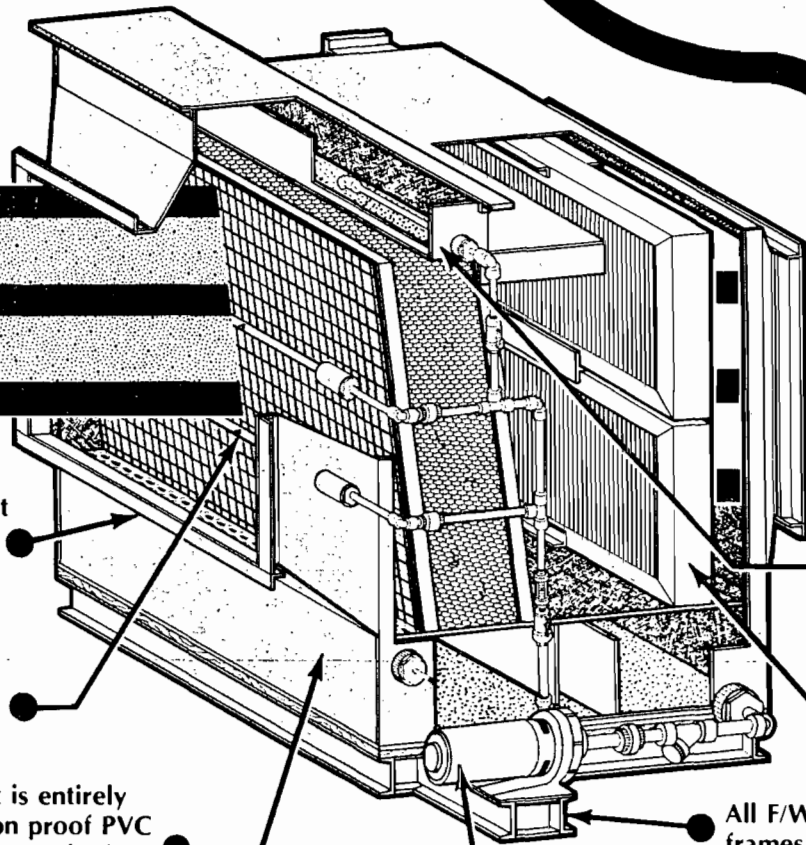

Flanged inlet and outlet make transition installation quick and trouble free.

Counterflow spray nozzles prewet fumes.

The packaged F/W unit is entirely constructed of corrosion proof PVC with polypropylene filter and mist eliminator packs.

An overflow weir keeps the polypropylene filter pack flooded with water.

Downstream mist eliminator packs pull excess moisture from the air stream.

All F/W units come with self supporting frames.

Units through Model F/W-9 are available with integral recirculation tank and pump as shown.

NOTE — Models F/W-10 through F/W-16 require remote recirculation tanks per manufacturers' suggestion.

-FW with integral recirculation tank.

-FW without integral recirculation tank.

FW	A	B	C	D	E	F	G	H	J	K	L	M	R	CHANNEL	ANGLE	DRAIN	G.P.M.	No. DF HEADERS	PIPE	CFM CAPACITY			
1	3'-11 1/2"	4'-4 1/2"	3'-6"	4'-3"	5'-3"	3'-4"	3'-4"	4'-10"	6"	6"	28"	28"	1'-8"	2'-0 1/4"	3'-0 1/4"	8"	4"@5.4#	1 1/2"x1 1/2"x3/16"	3"	8	2	3/4"	3,000 to 5,500
2	4'-3 1/2"	4'-8 1/2"	3'-10"	4'-6 1/4"	5'-6 1/4"	3'-8"	3'-4"	5'-2"	4 1/2"	4 1/2"	35"	35"	1'-10"	2'-2 1/4"	3'-2 1/4"	8"	4"@5.4#	1 1/2"x1 1/2"x3/16"	3"	9	2	3/4"	5,500 to 7,000
3	5'-0 1/2"	5'-5 1/2"	3'-6"	5'-3 1/4"	6'-3 3/4"	4'-5"	4'-5"	4'-10"	8"	8"	37"	37"	2'-4 1/2"	2'-7 1/4"	3'-7 1/4"	8"	4"@5.4#	1 1/2"x1 1/2"x3/16"	3"	12	2	3/4"	7,000 to 9,500
4	5'-6"	5'-11"	4'-0"	5'-8 1/4"	6'-8 1/4"	4'-10"	4'-10"	5'-6"	6 1/2"	6 1/2"	45"	45"	2'-5"	2'-9 1/4"	3'-9 1/4"	9"	4"@5.4#	2"x2"x1/4"	3"	14	2	3/4"	9,500 to 11,500
5	6'-0"	6'-5"	3'-8 1/2"	6'-2 1/4"	7'-2 1/4"	5'-4"	5'-4"	5'-2 1/2"	9 1/2"	9 1/2"	45"	45"	2'-8"	3'-0 1/4"	4'-0 1/4"	9"	4"@5.4#	2"x2"x1/4"	3"	16	2	3/4"	11,500 to 14,000
6	6'-8"	7'-1"	4'-1 1/2"	6'-10 1/4"	7'-10 1/4"	6'-0"	6'-0"	6'-1 1/2"	11"	11"	50"	50"	3'-0"	3'-4 1/4"	4'-4 1/4"	1'-0"	4"@5.4#	2"x2"x1/4"	3"	19	2	3/4"	14,000 to 17,000
7	6'-11"	7'-5"	3'-10 1/4"	7'-3"	8'-3"	6'-4"	6'-4"	5'-10 1/4"	11"	11"	54"	54"	3'-2"	3'-6 1/4"	4'-6 1/4"	1'-0"	4"@5.4#	2"x2"x1/4"	3"	22	2	3/4"	17,000 to 20,000
8	7'-8"	8'-1"	4'-3"	7'-10 1/4"	8'-10 1/4"	7'-0"	7'-0"	6'-3"	11'-0 1/2"	11'-0 1/2"	59"	59"	3'-6"	3'-9 1/4"	4'-9 1/4"	1'-0"	4"@5.4#	2"x2"x1/4"	3"	28	2	3/4"	20,000 to 24,000
9	8'-5"	9'-0"	4'-0 1/4"	8'-8"	9'-8"	7'-9"	7'-9"	6'-0 1/4"	11'-1 1/2"	11'-1 1/2"	66"	66"	3'-10 1/2"	4'-2 1/4"	5'-2 1/4"	1'-0"	4"@5.4#	2"x2"x1/4"	3"	34	3	1"	24,000 to 30,000
10	9'-7"		4'-5"	9'-11 1/4"		8'-11"	8'-11"	6'-5"	11'-3 1/2"	11'-3 1/2"	76"	76"	4'-5 1/2"	5'-0 1/4"		1'-0"	6"@8.2#	2"x2"x1/4"	3"	44	3	1"	30,000 to 40,000
11	12'-1"		4'-2 1/2"	9'-9 1/4"		8'-9"	11'-5"	6'-2 1/2"	10"	2'-2"	85"	85"	5'-8"	4'-11 1/4"		1'-0"	6"@8.2#	2"x2"x1/4"	3"	56	3	1"	40,000 to 50,000
12	14'-5"		4'-5 1/2"	9'-9 1/4"		8'-9"	13'-9"	8'-5 1/2"	10"	2'-7 1/2"	85"	102"	6'-10 1/2"	4'-11 1/4"		2'-0"	6"@8.2#	2"x2"x1/4"	3"	66	3	1"	50,000 to 60,000
14	17'-9"		4'-5 1/2"	9'-9 1/4"		8'-9"	17'-1"	8'-5 1/2"	10"	3'-2 1/2"	85"	128"	8'-5 1/2"	4'-11 1/4"		2'-0"	6"@8.2#	2"x2"x1/4"	3"	81	3	1"	60,000 to 75,000
15	20'-8"		4'-2 1/2"	9'-9 1/4"		8'-9"	19'-10"	8'-2 1/2"	10"	3'-9 1/2"	85"	147"	9'-11"	4'-11 1/4"		2'-0"	6"@8.2#	2"x2"x1/4"	3"	93	3	1 1/2"	75,000 to 87,000
16	20'-8"		4'-7"	11'-0 1/4"		10'-0"	20'-0"	8'-7"	11'-5 1/2"	3'-0"	85"	240"	10'-0"	5'-6 1/4"		2'-0"	6"@8.2#	2"x2"x1/4"	3"	106	3	1 1/2"	87,000 to 100,000

\* NOTE — For exact unit weight check with manufacturers.

\* NOTE — Double pack models are available where particularly heavy loadings exist. Check with manufacturer for dimensional changes.

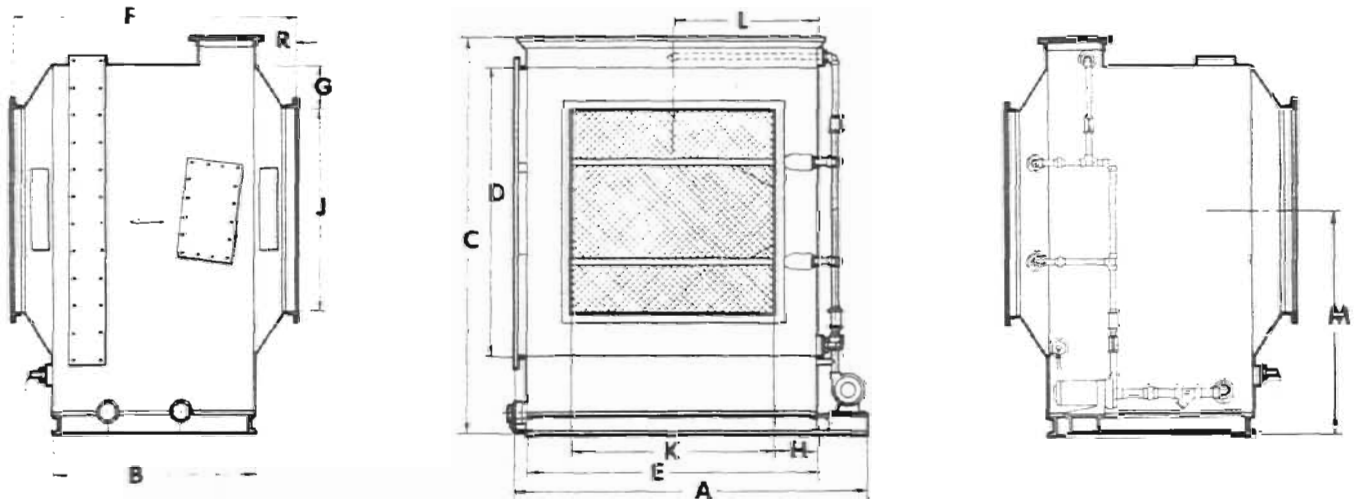

Typical three view drawing of units with integral recirculation tanks.

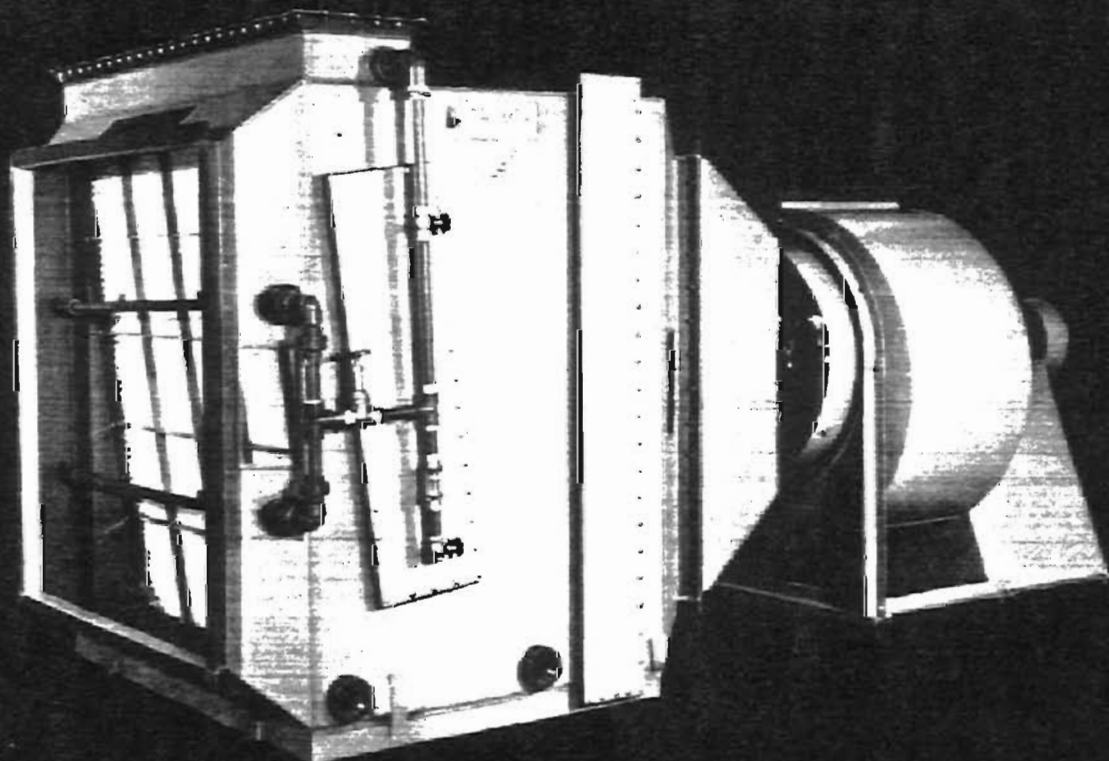

An assembled F.W-10 complete with Tri-Mer PVC Fan & Transition



# Other TRI-MER PVC Equipment

As long time specialists in designing corrosive fume control systems, TRI-MER offers a complete line of PVC air movers and associated equipment. This includes the patented fan/separator (fume scrubber), fume washers (crossflow scrubbers), PVC centrifugal fans, an *all PVC* stack fan, as well as PVC hoods and duct. Special fabrications such as consoles, tanks, and small plating lines are available.

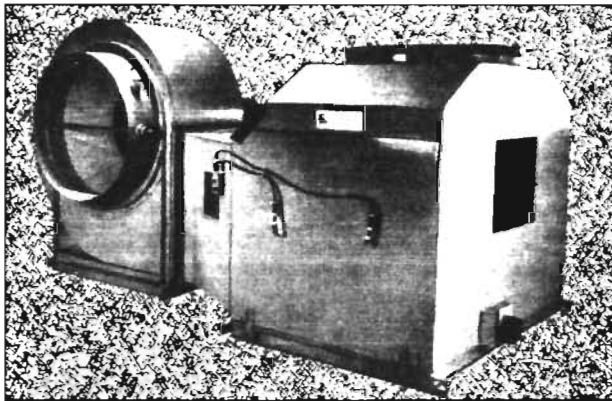

Fan/Separator

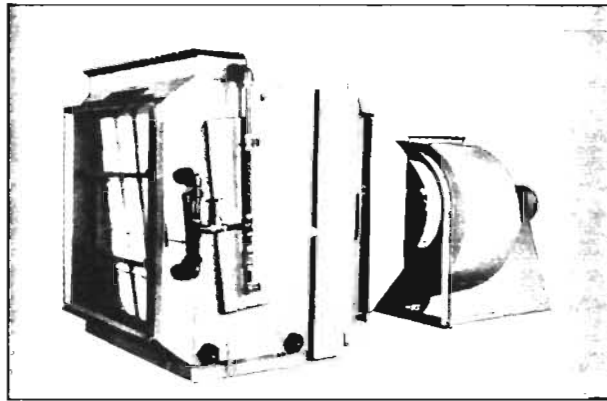

Fume Washer (Crossflow Scrubber)



PVC Centrifugal Fan

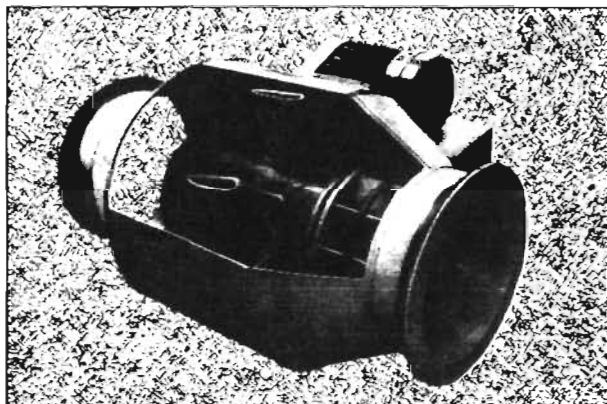

PVC Stack Fan (Cutaway View)

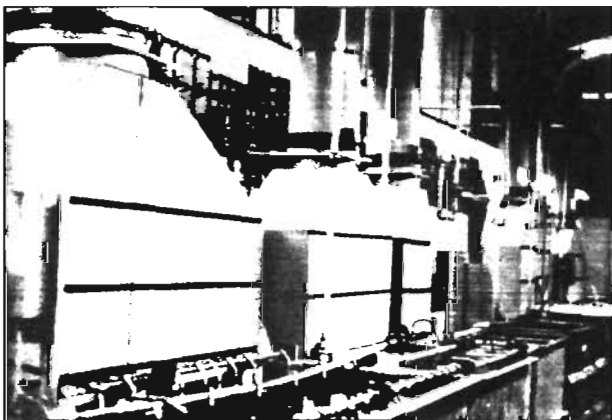

PVC Hoods & Duct

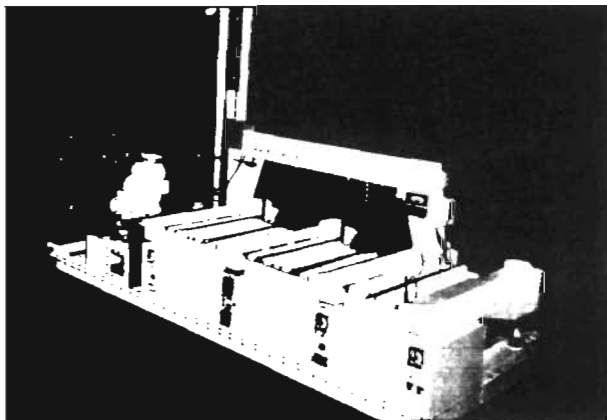

Special Fabrications



## Tri-Mer Corporation

Factory and Main Offices  
1400 Monroe, Owosso, Michigan 48867  
Phone: (517) 723 7838 Telex 228545



## Tri-Mer Corporation

California Sales Offices  
P.O. Box 1152, Costa Mesa, California 92626  
Phone: (714) 548 5853

**K** EUROPEAN REPRESENTATIVE  
**JAEGER K. G.**  
D BRAUNSCHWEIG, WEST GERMANY

*HARRIS SEMICONDUCTOR*

*AIR PERMIT - BUILDING 51*

*ATTACHMENT E*

*SITE LOCATION MAPS*

APOLLO BLVD

# Harris Semiconductor Complex

## SCRUBBER LOCATIONS

POND

F62S02  
F62S01

62B 62A

PARKING LOT  
F58S02  
F58S01

PARKING LOT

59

F57S01

58

PARKING LOT

POND

F59S01  
F59S03

63

F63S02  
F63S01  
F63S03

F54S03  
F54S04  
F54S01  
F54S02  
F60S01  
F55S01

54

PARKING LOT

F04S05  
F04S06  
F04S01

60

56

53

PARKING LOT

BORROW PIT

55

52

51

PARKING

PARKING LOT

6

TROUTMAN

F51S01  
F51S02  
F51S03  
F51S04  
F51S05

F04S08  
F04S04  
F04S03  
F04S02

F61S02  
F61S01

61

PARKING LOT

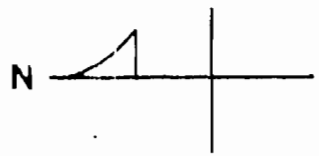

LIPSCOMB ST



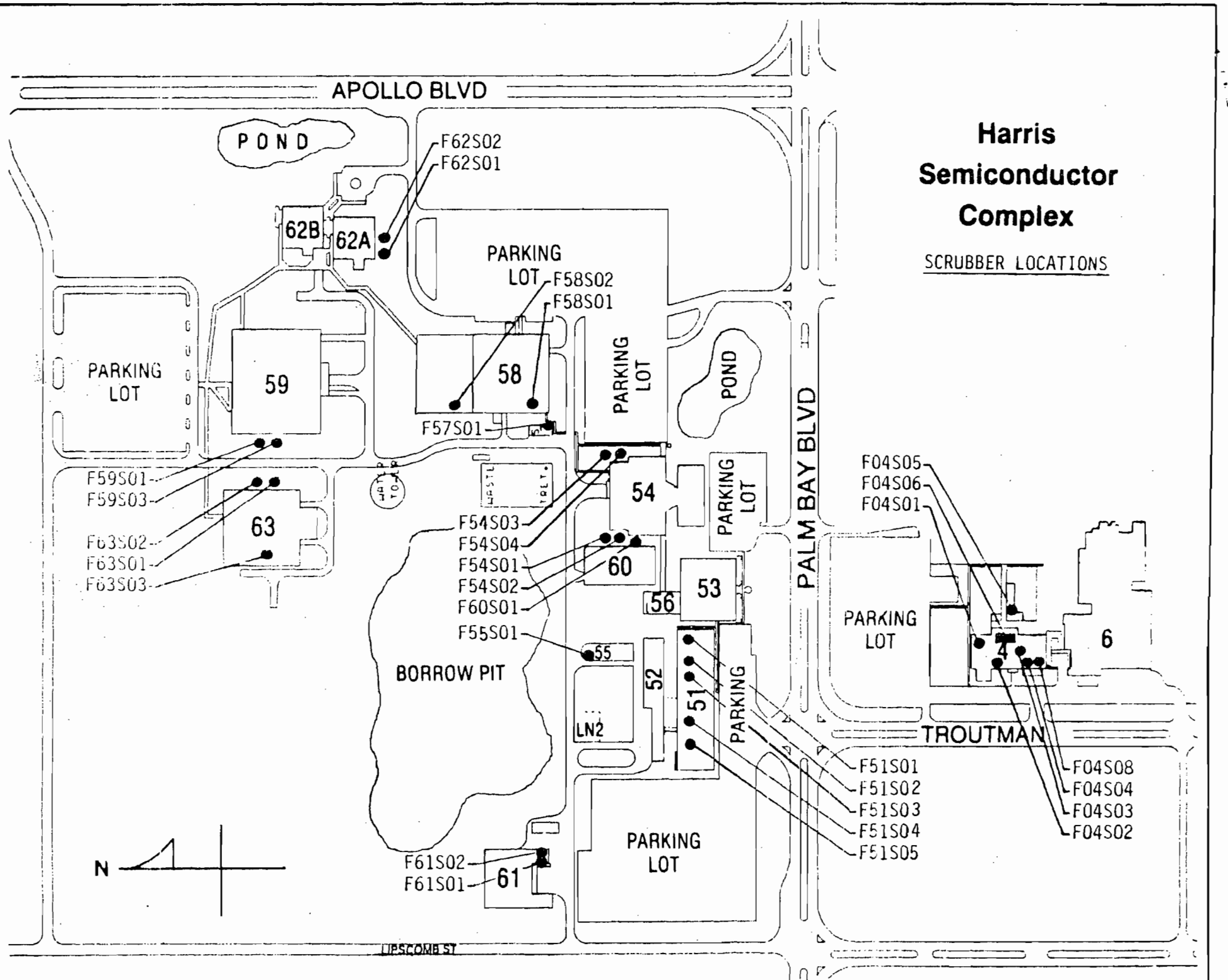

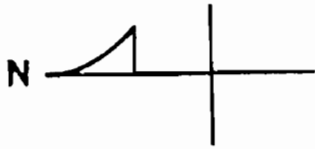

PALM BAY BLVD



HARRIS SEMICONDUCTOR  
SCRUBBER LOCATIONS  
BUILDING 51



LEGEND

-  - Horizontal Scrubber
-  - Vertical Scrubber
-  - Exhaust Stack
-  - Exhaust Fan
-  - Stack mounted on fan
-  - Epitaxial Scrubber

