



Application

AIR CONSTRUCTION AND TITLE V AIR OPERATION RENEWAL APPLICATION

Bay County Waste-To-Energy Facility

RECEIVED
FEB 01 2010

Prepared For: Bay County Utility Services Department
6510 Bay Line Drive
Panama City, FL 32404 USA

BUREAU OF AIR REGULATION

Submitted By: Golder Associates Inc.
6026 NW 1st Place
Gainesville, FL 32607 USA

January 2010

093-87678

A world of
capabilities
delivered locally



APPLICATION FOR AIR PERMIT
LONG FORM



Department of Environmental Protection

Division of Air Resource Management

APPLICATION FOR AIR PERMIT - LONG FORM

I. APPLICATION INFORMATION

Air Construction Permit – Use this form to apply for an air construction permit:

- For any required purpose at a facility operating under a federally enforceable state air operation permit (FESOP) or Title V air operation permit;
- For a proposed project subject to prevention of significant deterioration (PSD) review, nonattainment new source review, or maximum achievable control technology (MACT);
- To assume a restriction on the potential emissions of one or more pollutants to escape a requirement such as PSD review, nonattainment new source review, MACT, or Title V; or
- To establish, revise, or renew a plantwide applicability limit (PAL).

Air Operation Permit – Use this form to apply for:

- An initial federally enforceable state air operation permit (FESOP); or
- An initial, revised, or renewal Title V air operation permit.

RECEIVED

FEB 01 2010

BUREAU OF AIR REGULATION

To ensure accuracy, please see form instructions.

Identification of Facility

1. Facility Owner/Company Name: Bay County Utility Services Department	
2. Site Name: Bay County Waste-to-Energy Facility	
3. Facility Identification Number: 0050031	
4. Facility Location... Street Address or Other Locator: 6510 Bay Line Drive City: Panama City County: Bay Zip Code: 32404	
5. Relocatable Facility? <input type="checkbox"/> Yes <input checked="" type="checkbox"/> No	6. Existing Title V Permitted Facility? <input checked="" type="checkbox"/> Yes <input type="checkbox"/> No

Application Contact

1. Application Contact Name: Richard Brookins, Plant Engineer & EH&S Manager	
2. Application Contact Mailing Address... Organization/Firm: EnGen, LLC Street Address: 6510 Bay Line Drive City: Panama City State: Florida Zip Code: 32404	
3. Application Contact Telephone Numbers... Telephone: (850) 747-5760 ext. 203 Fax: (850) 747-5768	
4. Application Contact E-mail Address: brookinsr@engenllc.com	

Application Processing Information (DEP Use)

1. Date of Receipt of Application: 02/01/10	3. PSD Number (if applicable):
2. Project Number(s): 0050031-02-A9	4. Siting Number (if applicable):

0050031-03-AV

APPLICATION INFORMATION

Purpose of Application

This application for air permit is being submitted to obtain: (Check one)

Air Construction Permit

- Air construction permit.
- Air construction permit to establish, revise, or renew a plantwide applicability limit (PAL).
- Air construction permit to establish, revise, or renew a plantwide applicability limit (PAL), and separate air construction permit to authorize construction or modification of one or more emissions units covered by the PAL.

Air Operation Permit

- Initial Title V air operation permit.
- Title V air operation permit revision.
- Title V air operation permit renewal.
- Initial federally enforceable state air operation permit (FESOP) where professional engineer (PE) certification is required.
- Initial federally enforceable state air operation permit (FESOP) where professional engineer (PE) certification is not required.

Air Construction Permit and Revised/Renewal Title V Air Operation Permit (Concurrent Processing)

- Air construction permit and Title V permit revision, incorporating the proposed project.
- Air construction permit and Title V permit renewal, incorporating the proposed project.

Note: By checking one of the above two boxes, you, the applicant, are requesting concurrent processing pursuant to Rule 62-213.405, F.A.C. In such case, you must also check the following box:

- I hereby request that the department waive the processing time requirements of the air construction permit to accommodate the processing time frames of the Title V air operation permit.

Application Comment

This application is to renew the facility's Title V Air Operation Permit. The current Title V permit number is 0050031-010-AV. Bay County is also proposing to re-rate the existing facility from 245 tons per day (TPD) at 4,500 British thermal units per pound (Btu/lb) of municipal solid waste (MSW) per unit to 255 TPD MSW at 4,500 Btu/lb per unit, which is the original unit capacity.

APPLICATION INFORMATION

Scope of Application

Emissions Unit ID Number	Description of Emissions Unit	Air Permit Type	Air Permit Processing Fee
001	Municipal Waste Combustion Unit No. 1 (North)		NA
002	Municipal Waste Combustion Unit No. 2 (South)		NA
	Miscellaneous Unregulated Emission Units		

Application Processing Fee

Check one: Attached - Amount: \$ _____ Not Applicable

APPLICATION INFORMATION

Owner/Authorized Representative Statement

Complete if applying for an air construction permit or an initial FESOP.

1. Owner/Authorized Representative Name :
2. Owner/Authorized Representative Mailing Address... Organization/Firm: Street Address: City: State: Zip Code:
3. Owner/Authorized Representative Telephone Numbers... Telephone: () ext. Fax: ()
4. Owner/Authorized Representative E-mail Address:
5. Owner/Authorized Representative Statement: <i>I, the undersigned, am the owner or authorized representative of the corporation, partnership, or other legal entity submitting this air permit application. To the best of my knowledge, the statements made in this application are true, accurate and complete, and any estimates of emissions reported in this application are based upon reasonable techniques for calculating emissions. I understand that a permit, if granted by the department, cannot be transferred without authorization from the department.</i> _____ Signature Date

APPLICATION INFORMATION

Application Responsible Official Certification

Complete if applying for an initial, revised, or renewal Title V air operation permit or concurrent processing of an air construction permit and revised or renewal Title V air operation permit. If there are multiple responsible officials, the "application responsible official" need not be the "primary responsible official."

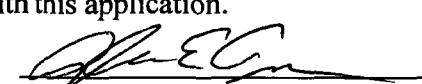
1. Application Responsible Official Name: Glenn Ogborn, Solid Waste Superintendent
2. Application Responsible Official Qualification (Check one or more of the following options, as applicable): <input type="checkbox"/> For a corporation, the president, secretary, treasurer, or vice-president of the corporation in charge of a principal business function, or any other person who performs similar policy or decision-making functions for the corporation, or a duly authorized representative of such person if the representative is responsible for the overall operation of one or more manufacturing, production, or operating facilities applying for or subject to a permit under Chapter 62-213, F.A.C. <input type="checkbox"/> For a partnership or sole proprietorship, a general partner or the proprietor, respectively. <input checked="" type="checkbox"/> For a municipality, county, state, federal, or other public agency, either a principal executive officer or ranking elected official. <input type="checkbox"/> The designated representative at an Acid Rain source, CAIR source, or Hg Budget source.
3. Application Responsible Official Mailing Address... Organization/Firm: Bay County Utility Services Street Address: 3410 Transmitter Rd City: Panama City State: Florida Zip Code: 32404
4. Application Responsible Official Telephone Numbers... Telephone: (850) 784-4028 ext. Fax: (850) 872-4805
5. Application Responsible Official E-mail Address:
6. Application Responsible Official Certification: I, the undersigned, am a responsible official of the Title V source addressed in this air permit application. I hereby certify, based on information and belief formed after reasonable inquiry, that the statements made in this application are true, accurate and complete and that, to the best of my knowledge, any estimates of emissions reported in this application are based upon reasonable techniques for calculating emissions. The air pollutant emissions units and air pollution control equipment described in this application will be operated and maintained so as to comply with all applicable standards for control of air pollutant emissions found in the statutes of the State of Florida and rules of the Department of Environmental Protection and revisions thereof and all other applicable requirements identified in this application to which the Title V source is subject. I understand that a permit, if granted by the department, cannot be transferred without authorization from the department, and I will promptly notify the department upon sale or legal transfer of the facility or any permitted emissions unit. Finally, I certify that the facility and each emissions unit are in compliance with all applicable requirements to which they are subject, except as identified in compliance plan(s) submitted with this application.  Signature <u>1-26-10</u> Date

APPLICATION INFORMATION

Professional Engineer Certification

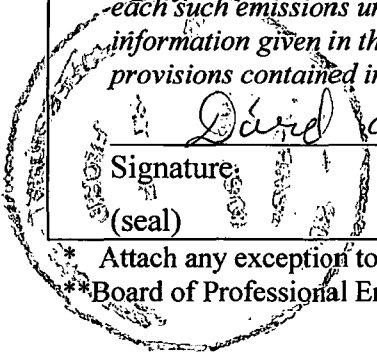
1. Professional Engineer Name: David A. Buff Registration Number: 19011
2. Professional Engineer Mailing Address... Organization/Firm: Golder Associates Inc.** Street Address: 6026 NW 1st Place City: Gainesville State: FL Zip Code: 32607
3. Professional Engineer Telephone Numbers... Telephone: (352) 336-5600 ext. Fax: (352) 336-6603
4. Professional Engineer E-mail Address: dbuff@golder.com
5. Professional Engineer Statement: <i>I, the undersigned, hereby certify, except as particularly noted herein*, that:</i> <i>(1) To the best of my knowledge, there is reasonable assurance that the air pollutant emissions unit(s) and the air pollution control equipment described in this application for air permit, when properly operated and maintained, will comply with all applicable standards for control of air pollutant emissions found in the Florida Statutes and rules of the Department of Environmental Protection; and</i> <i>(2) To the best of my knowledge, any emission estimates reported or relied on in this application are true, accurate, and complete and are either based upon reasonable techniques available for calculating emissions or, for emission estimates of hazardous air pollutants not regulated for an emissions unit addressed in this application, based solely upon the materials, information and calculations submitted with this application.</i> <i>(3) If the purpose of this application is to obtain a Title V air operation permit (check here <input type="checkbox"/> , if so), I further certify that each emissions unit described in this application for air permit, when properly operated and maintained, will comply with the applicable requirements identified in this application to which the unit is subject, except those emissions units for which a compliance plan and schedule is submitted with this application.</i> <i>(4) If the purpose of this application is to obtain an air construction permit (check here <input type="checkbox"/> , if so) or concurrently process and obtain an air construction permit and a Title V air operation permit revision or renewal for one or more proposed new or modified emissions units (check here <input checked="" type="checkbox"/> , if so), I further certify that the engineering features of each such emissions unit described in this application have been designed or examined by me or individuals under my direct supervision and found to be in conformity with sound engineering principles applicable to the control of emissions of the air pollutants characterized in this application.</i> <i>(5) If the purpose of this application is to obtain an initial air operation permit or operation permit revision or renewal for one or more newly constructed or modified emissions units (check here <input type="checkbox"/> , if so), I further certify that, with the exception of any changes detailed as part of this application, each such emissions unit has been constructed or modified in substantial accordance with the information given in the corresponding application for air construction permit and with all provisions contained in such permit.</i>  Signature: <u>David A. Buff</u> Date: <u>1/29/2010</u> (seal)

Attach any exception to certification statement.

**Board of Professional Engineers Certificate of Authorization #00001670.

II. FACILITY INFORMATION

A. GENERAL FACILITY INFORMATION

Facility Location and Type

1. Facility UTM Coordinates...		2. Facility Latitude/Longitude...	
Zone 16	East (km) 642.40	Latitude (DD/MM/SS) 30/15/54	Longitude (DD/MM/SS) 85/30/08
	North (km) 3349.50		
3. Governmental Facility Code:	4. Facility Status Code:	5. Facility Major Group SIC Code:	6. Facility SIC(s):
3	A	49	4953, 4911
7. Facility Comment :			

Facility Contact

1. Facility Contact Name: Richard Brookins, Plant Engineer & EH&S Manager
2. Facility Contact Mailing Address... Organization/Firm: EnGen, LLC Street Address: 6510 Bay Line Drive City: Panama City State: Florida Zip Code: 32404
3. Facility Contact Telephone Numbers: Telephone: (850) 747-5760 ext. 203 Fax: (850) 747-5768
4. Facility Contact E-mail Address: brookinsr@engenllc.com

Facility Primary Responsible Official

Complete if an "application responsible official" is identified in Section I that is not the facility "primary responsible official."

1. Facility Primary Responsible Official Name:
2. Facility Primary Responsible Official Mailing Address... Organization/Firm: Street Address: City: State: Zip Code:
3. Facility Primary Responsible Official Telephone Numbers... Telephone: () ext. Fax: ()
4. Facility Primary Responsible Official E-mail Address:

Facility Regulatory Classifications

Check all that would apply *following* completion of all projects and implementation of all other changes proposed in this application for air permit. Refer to instructions to distinguish between a "major source" and a "synthetic minor source."

1. <input type="checkbox"/> Small Business Stationary Source	<input type="checkbox"/> Unknown
2. <input type="checkbox"/> Synthetic Non-Title V Source	
3. <input checked="" type="checkbox"/> Title V Source	
4. <input checked="" type="checkbox"/> Major Source of Air Pollutants, Other than Hazardous Air Pollutants (HAPs)	
5. <input type="checkbox"/> Synthetic Minor Source of Air Pollutants, Other than HAPs	
6. <input checked="" type="checkbox"/> Major Source of Hazardous Air Pollutants (HAPs)	
7. <input type="checkbox"/> Synthetic Minor Source of HAPs	
8. <input checked="" type="checkbox"/> One or More Emissions Units Subject to NSPS (40 CFR Part 60)	
9. <input checked="" type="checkbox"/> One or More Emissions Units Subject to Emission Guidelines (40 CFR Part 60)	
10. <input type="checkbox"/> One or More Emissions Units Subject to NESHAP (40 CFR Part 61 or Part 63)	
11. <input type="checkbox"/> Title V Source Solely by EPA Designation (40 CFR 70.3(a)(5))	
12. Facility Regulatory Classifications Comment:	

List of Pollutants Emitted by Facility

1. Pollutant Emitted	2. Pollutant Classification	3. Emissions Cap [Y or N]?
PM - Particulate Matter Total	B	N
PM10 - Particulate Matter ≤ 10 microns	B	N
PM2.5 - Particulate Matter ≤ 2.5 microns	B	N
VOC - Volatile Organic Compounds	B	N
H027 - Cadmium	B	N
PB - Lead	B	N
NOx - Nitrogen Oxides	A	N
CO - Carbon Monoxide	A	N
D/F - Dioxin/Furan	B	N
SO2 - Sulfur Dioxide	B	N
H106 - Hydrogen Chloride	A	N
H114 - Mercury	B	N
FL - Fluorides	B	N
H021 - Beryllium Compounds	B	N
SAM - Sulfuric Acid Mist	B	N
HAPs - Total Hazardous Air Pollutants	A	N

B. EMISSIONS CAPS

Facility-Wide or Multi-Unit Emissions Caps

1. Pollutant Subject to Emissions Cap	2. Facility-Wide Cap [Y or N]? (all units)	3. Emissions Unit ID's Under Cap (if not all units)	4. Hourly Cap (lb/hr)	5. Annual Cap (ton/yr)	6. Basis for Emissions Cap

7. Facility-Wide or Multi-Unit Emissions Cap Comment:

C. FACILITY ADDITIONAL INFORMATION

Additional Requirements for All Applications, Except as Otherwise Stated

1. Facility Plot Plan: (Required for all permit applications, except Title V air operation permit revision applications if this information was submitted to the department within the previous five years and would not be altered as a result of the revision being sought) <input checked="" type="checkbox"/> Attached, Document ID: <u>BC-FI-C1</u> <input type="checkbox"/> Previously Submitted, Date: _____
2. Process Flow Diagram(s): (Required for all permit applications, except Title V air operation permit revision applications if this information was submitted to the department within the previous five years and would not be altered as a result of the revision being sought) <input checked="" type="checkbox"/> Attached, Document ID: <u>BC-FI-C2</u> <input type="checkbox"/> Previously Submitted, Date: _____
3. Precautions to Prevent Emissions of Unconfined Particulate Matter: (Required for all permit applications, except Title V air operation permit revision applications if this information was submitted to the department within the previous five years and would not be altered as a result of the revision being sought) <input checked="" type="checkbox"/> Attached, Document ID: <u>BC-FI-C3</u> <input type="checkbox"/> Previously Submitted, Date: _____

Additional Requirements for Air Construction Permit Applications

1. Area Map Showing Facility Location: <input type="checkbox"/> Attached, Document ID: _____ <input checked="" type="checkbox"/> Not Applicable (existing permitted facility)
2. Description of Proposed Construction, Modification, or Plantwide Applicability Limit (PAL): <input checked="" type="checkbox"/> Attached, Document ID: <u>Attachment A</u>
3. Rule Applicability Analysis: <input checked="" type="checkbox"/> Attached, Document ID: <u>Attachment A</u>
4. List of Exempt Emissions Units: <input type="checkbox"/> Attached, Document ID: _____ <input checked="" type="checkbox"/> Not Applicable (no exempt units at facility)
5. Fugitive Emissions Identification: <input checked="" type="checkbox"/> Attached, Document ID: <u>Attachment A</u> <input type="checkbox"/> Not Applicable
6. Air Quality Analysis (Rule 62-212.400(7), F.A.C.): <input type="checkbox"/> Attached, Document ID: _____ <input checked="" type="checkbox"/> Not Applicable
7. Source Impact Analysis (Rule 62-212.400(5), F.A.C.): <input type="checkbox"/> Attached, Document ID: _____ <input checked="" type="checkbox"/> Not Applicable
8. Air Quality Impact since 1977 (Rule 62-212.400(4)(e), F.A.C.): <input type="checkbox"/> Attached, Document ID: _____ <input checked="" type="checkbox"/> Not Applicable
9. Additional Impact Analyses (Rules 62-212.400(8) and 62-212.500(4)(e), F.A.C.): <input type="checkbox"/> Attached, Document ID: _____ <input checked="" type="checkbox"/> Not Applicable
10. Alternative Analysis Requirement (Rule 62-212.500(4)(g), F.A.C.): <input type="checkbox"/> Attached, Document ID: _____ <input checked="" type="checkbox"/> Not Applicable

C. FACILITY ADDITIONAL INFORMATION (CONTINUED)

Additional Requirements for FESOP Applications

1. List of Exempt Emissions Units:
 Attached, Document ID: _____ Not Applicable (no exempt units at facility)

Additional Requirements for Title V Air Operation Permit Applications

1. List of Insignificant Activities: (Required for initial/renewal applications only)
 Attached, Document ID: BC-FI-CV1 Not Applicable (revision application)
2. Identification of Applicable Requirements: (Required for initial/renewal applications, and for revision applications if this information would be changed as a result of the revision being sought)
 Attached, Document ID: BC-FI-CV2
 Not Applicable (revision application with no change in applicable requirements)
3. Compliance Report and Plan: (Required for all initial/revision/renewal applications)
 Attached, Document ID: BC-FI-CV3
Note: A compliance plan must be submitted for each emissions unit that is not in compliance with all applicable requirements at the time of application and/or at any time during application processing. The department must be notified of any changes in compliance status during application processing.
4. List of Equipment/Activities Regulated under Title VI: (If applicable, required for initial/renewal applications only)
 Attached, Document ID: _____
 Equipment/Activities Onsite but Not Required to be Individually Listed
 Not Applicable
5. Verification of Risk Management Plan Submission to EPA: (If applicable, required for initial/renewal applications only)
 Attached, Document ID: _____ Not Applicable
6. Requested Changes to Current Title V Air Operation Permit:
 Attached, Document ID: Attachment A Not Applicable

C. FACILITY ADDITIONAL INFORMATION (CONTINUED)

Additional Requirements for Facilities Subject to Acid Rain, CAIR, or Hg Budget Program

<p>1. Acid Rain Program Forms:</p> <p>Acid Rain Part Application (DEP Form No. 62-210.900(1)(a)):</p> <p><input type="checkbox"/> Attached, Document ID: _____ <input type="checkbox"/> Previously Submitted, Date: _____</p> <p><input checked="" type="checkbox"/> Not Applicable (not an Acid Rain source)</p> <p>Phase II NO_x Averaging Plan (DEP Form No. 62-210.900(1)(a)1.):</p> <p><input type="checkbox"/> Attached, Document ID: _____ <input type="checkbox"/> Previously Submitted, Date: _____</p> <p><input checked="" type="checkbox"/> Not Applicable</p> <p>New Unit Exemption (DEP Form No. 62-210.900(1)(a)2.):</p> <p><input type="checkbox"/> Attached, Document ID: _____ <input type="checkbox"/> Previously Submitted, Date: _____</p> <p><input checked="" type="checkbox"/> Not Applicable</p>
<p>2. CAIR Part (DEP Form No. 62-210.900(1)(b)):</p> <p><input type="checkbox"/> Attached, Document ID: _____ <input type="checkbox"/> Previously Submitted, Date: _____</p> <p><input checked="" type="checkbox"/> Not Applicable (not a CAIR source)</p>
<p>3. Hg Budget Part (DEP Form No. 62-210.900(1)(c)):</p> <p><input type="checkbox"/> Attached, Document ID: _____ <input type="checkbox"/> Previously Submitted, Date: _____</p> <p><input checked="" type="checkbox"/> Not Applicable (not a Hg Budget unit)</p>

Additional Requirements Comment

ATTACHMENT BC-FI-C1
FACILITY PLOT PLAN

SPECIFIC PURPOSE SURVEY



0 25' 50' 100'

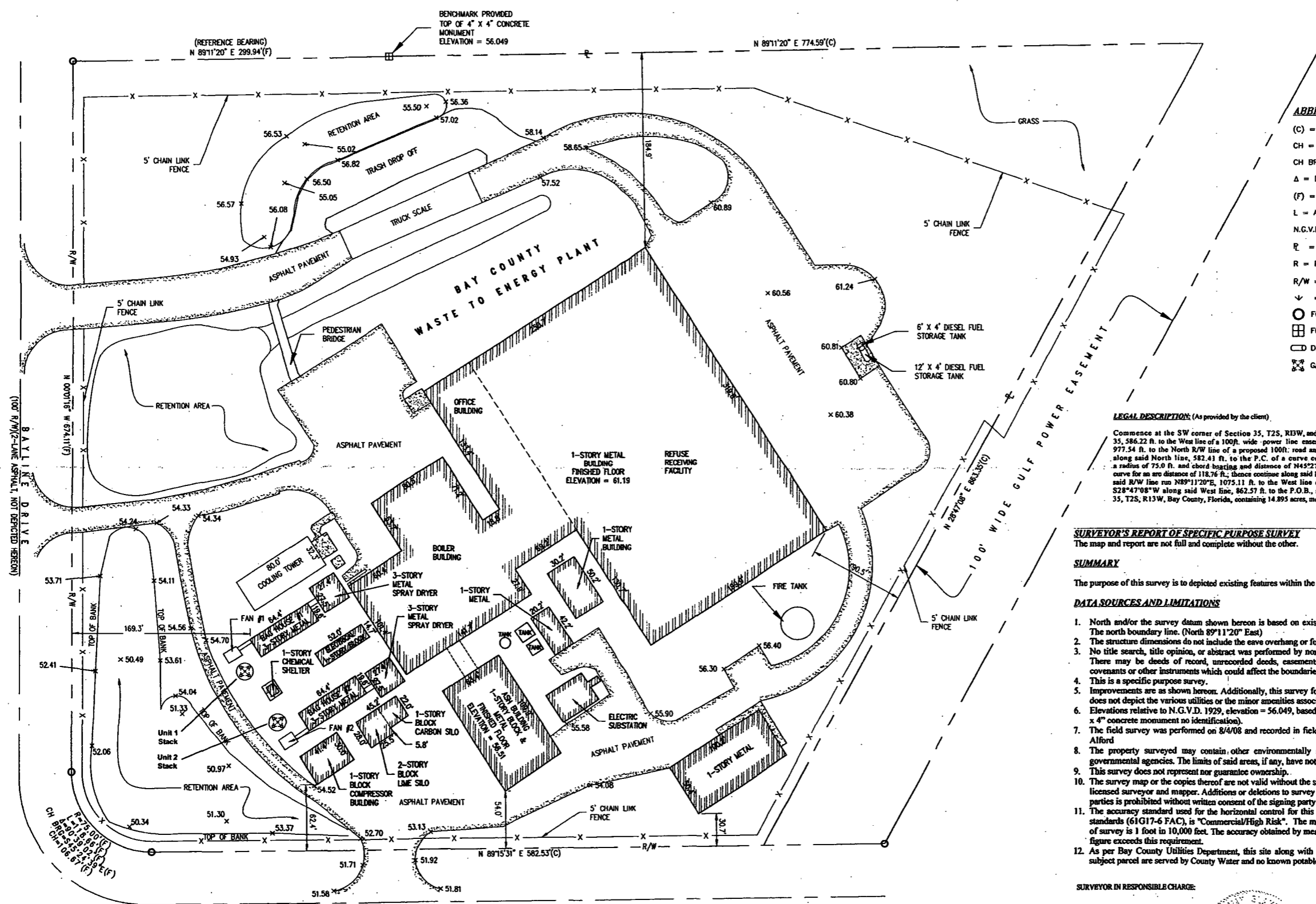

ABBREVIATIONS AND SYMBOLS LEGEND

- (C) = CALCULATED MEASUREMENT
- CH = CHORD DISTANCE
- CH BRG = CHORD BEARING
- Δ = DELTA ANGLE
- (F) = FIELD MEASUREMENT
- L = ARC LENGTH
- N.G.V.D. = NATIONAL GEODETIC VERTICAL DATUM
- R_L = PROPERTY LINE
- R = RADIUS
- R/W = RIGHT-OF-WAY
- ⋄ = WETLANDS
- FOUND 1/2" IRON ROD "NO ID."
- FOUND 4"x4" CONCRETE MONUMENT "NO ID."
- ◻ DIESEL FUEL TANK
- ⊗ GAS STACK

LEGAL DESCRIPTION: (As provided by the client)

Commence at the SW corner of Section 35, T2S, R13W, and run N89°12'08"E along the South line of said Section 35, 586.22 ft. to the West line of a 100ft. wide power line easement; thence N28°47'08"E along said West line 977.54 ft. to the North R/W line of a proposed 100ft. road and the Point of Beginning; thence S89°11'20"W along said North line, 582.41 ft. to the P.C. of a curve concave Northeasterly having a delta of 90° 43'41", a radius of 75.0 ft. and chord bearing and distance of N44°27'41"W, 106.74 ft.; thence Northeasterly along said curve for an arc distance of 118.76 ft.; thence continue along said R/W line N00°06'12"W, 674.14 ft.; thence departing said R/W line run N89°11'20"E, 1075.11 ft. to the West line of a 100 ft. wide power line easement; thence S28°47'08"W along said West line, 862.57 ft. to the P.O.B., said parcel being located in the SW1/4 of Section 35, T2S, R13W, Bay County, Florida, containing 14.895 acres, more or less.

SURVEYOR'S REPORT OF SPECIFIC PURPOSE SURVEY

The map and report are not full and complete without the other.

SUMMARY

The purpose of this survey is to depict existing features within the Bay County Waste To Energy Plant.

DATA SOURCES AND LIMITATIONS

1. North and/or the survey datum shown hereon is based on existing field monumentation and deeds of record. The north boundary line. (North 89°11'20" East)
2. The structure dimensions do not include the eave overhang or foundation footings.
3. No title search, title opinion, or abstract was performed by nor provided to this firm for the subject property. There may be deeds of record, unrecorded deeds, easements, rights-of-way, building setbacks, restrictive covenants or other instruments which could affect the boundaries or use of the subject property.
4. This is a specific purpose survey.
5. Improvements are as shown hereon. Additionally, this survey focused on the major features (i.e. buildings) and does not depict the various utilities or the minor amenities associated with each building.
6. Elevations relative to N.G.V.D. 1929, elevation = 56.049, based on benchmark provided by the client (found 4" x 4" concrete monument no identification).
7. The field survey was performed on 8/4/08 and recorded in field book T08/06, page(s) 6-16. Crew Chief: John Alford
8. The property surveyed may contain other environmentally sensitive areas subject to the jurisdiction by governmental agencies. The limits of said areas, if any, have not been located or shown hereon.
9. This survey does not represent nor guarantee ownership.
10. The survey map or the copies thereof are not valid without the signature and the original raised seal of a Florida licensed surveyor and mapper. Additions or deletions to survey map or maps by other than the signing party or parties is prohibited without written consent of the signing party or parties.
11. The accuracy standard used for the horizontal control for this survey, as classified in the minimum technical standards (61G17-6 FAC), is "Commercial/High Risk". The minimum relative distance accuracy for this type of survey is 1 foot in 10,000 feet. The accuracy obtained by measurement and calculation of a closed geometric figure exceeds this requirement.
12. As per Bay County Utilities Department, this site along with the other buildings located within 500' of the subject parcel are served by County Water and no known potable wells exist within this vicinity.

SURVEYOR IN RESPONSIBLE CHARGE:
 For: Baskerville-Donovan Inc.
 Corporate No. LB 0340
 By:
 Jeremiah J. Baskerville, P.E.S.M.
 Florida Registration No. 6387
 NOT VALID WITHOUT THE SIGNATURE AND ORIGINAL RAISED SEAL OF A FLORIDA LICENSED SURVEYOR AND MAPPER.

Bay County
 Utility Services Dept.
 AUG 12 2008
 Received

BASKERVILLE-DONOVAN, INC.
 INNOVATIVE INFRASTRUCTURE SOLUTIONS
 PRINCIPAL OFFICE: PALM BEACH, FLORIDA
 TALLAHASSEE, FLORIDA
 SURVEYING BUSINESS: 12-0000940

**BAY COUNTY
 WASTE TO ENERGY PLANT
 SECTION 35, TOWNSHIP 2
 SOUTH, RANGE 13 WEST, BAY
 COUNTY, FLORIDA**

NO.	DATE	APPRO.	REVISION/ACTION TAKEN

PROJECT NO.: 08250.01	SCALE: 1" = 50'	DRAWN BY: DAY	NOT RELEASED FOR CONSTRUCTION
CHK'D BY: JS	PRCL. MGR.: NPN	DATE: 08/08/2008	BY: _____

**SPECIFIC PURPOSE SURVEY
 PREPARED FOR / CERTIFIED TO:
 BAY COUNTY BOARD OF
 COUNTY COMMISSIONERS**

1 OF 1

J:\Survey\08250.01.WEP(DWG)\08250.01.WEP_CHK.dwg, Aug 11, 2008 - 3:02:17PM, evntline

ATTACHMENT BC-FI-C2
PROCESS FLOW DIAGRAM

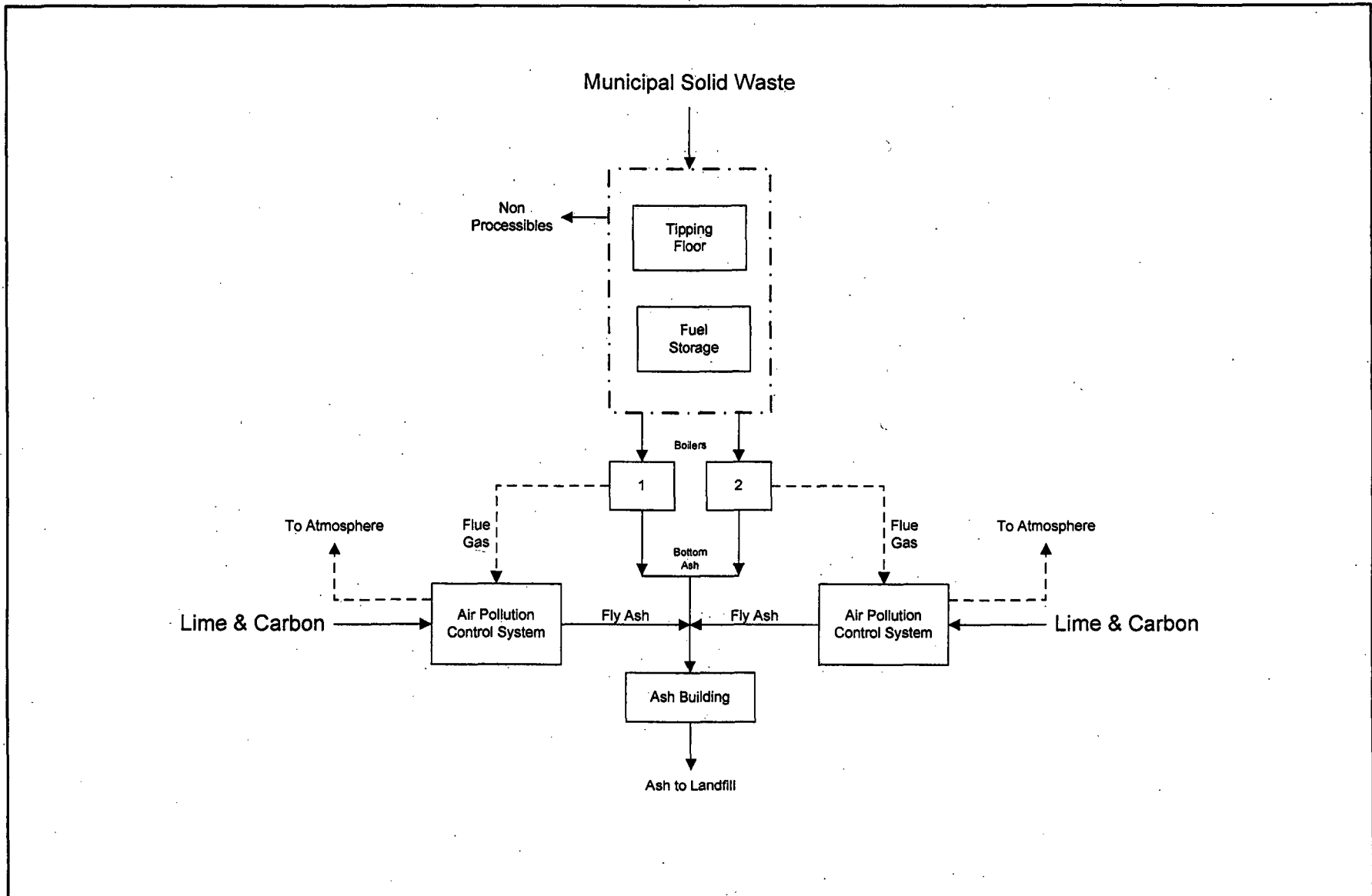

Attachment BC-FI-C2
 Facility Process Flow Diagram
 Bay County Waste-to-Energy Facility

Process Flow Legend	
Solid/Liquid	—————>
Gas	- - - - ->
Building	->



ATTACHMENT BC-FI-C3

**PRECAUTIONS TO PREVENT EMISSIONS OF
UNCONFINED PARTICULATE MATTER**

ATTACHMENT BC-FI-C3
PRECAUTIONS TO PREVENT EMISSIONS OF
UNCONFINED PARTICULATE MATTER

Reasonable precautions shall be taken to prevent emissions of unconfined particulate matter. Reasonable precautions shall include, but are not limited to, the following:

- **Paved and Unpaved Roads.** Trucks delivering municipal solid waste (MSW), trucks removing ash, passenger vehicles, and other plant equipment use only paved roads at the facility. To minimize emissions from the paved roadways, a road sweeper is utilized to clean the areas twice per month.
- **Residue Handling.** The residual material (ash) remaining after the solid waste is combusted is transported via conveyor into the ash building to be loaded and hauled to the landfill. The ash is handled wet in order to minimize emissions. All ash is combined inside the boiler building and sent to the quench tank where it is submerged in water. A drag conveyor lifts the material from the quench tank up an incline to allow standing water to drain. The material is then discharged into an Ash Building and then loaded into a truck or roll-off container. The trucks or roll-off containers are covered before they exit the site.

ATTACHMENT BC-FI-CV1
LIST OF INSIGNIFICANT ACTIVITIES

ATTACHMENT BC-FI-CV1

LIST OF INSIGNIFICANT ACTIVITIES

A list of existing units and/or activities that are considered to be insignificant and are exempted from Title V permitting under Rule 62-213.430(6), Florida Administrative Code (F.A.C.), is presented below. The exempt activities listed are also those activities that are included in Rule 62-210.300(3)(a), F.A.C., that would not exceed the thresholds in Rule 62-213.430(6)(b)3, F.A.C.

Brief Description of Emissions Units and/or Activities:

- Plant Grounds Maintenance (small engines)
- Maintenance and Repair Activities (cleaning, painting, etc)
- Main Steam Pressure Relief Valves
- Office Activities (vacuum cleaning, refrigerators, etc.)
- Chemical Storage Tanks [sulfuric acid: 1,200 gallons (gal) and 3,000 gal; caustic soda: 1,200 gal, etc.]
- Testing and Monitoring Equipment (CEMs, stack sampling calibration gases, etc.)
- Fire/Safety Diesel Pump
- Heating, Ventilation, and Air Conditioning (HVAC) Equipment
- Various Vents/Exhausts (boiler feed pump relief valve, etc.)
- Air Compressors
- Waste Accumulation (10-gal closed containers)
- Fuel Oil Storage Tanks (1,000 gal, and 250 gal)
- Laboratory Vents
- Cooling Tower
- Transportation/Conveying and Hauling of Waste and Ash
- Fugitive Emissions from Vehicular Traffic on Plant Roads
- Lime and Carbon Silos, each with a Bag Filter
- Slakers (two: lime slurry injection)
- Natural Gas Line
- Demineralizer System

ATTACHMENT BC-FI-CV2
IDENTIFICATION OF APPLICABLE REQUIREMENTS

ATTACHMENT BC-FI-CV2**TITLE V CORE LIST**

Effective: 03/01/02

(Updated based on current version of FDEP Air Rules)

[Note: The Title V Core List is meant to simplify the completion of the "List of Applicable Regulations" for DEP Form No. 62-210.900(1), Application for Air Permit - Long Form. The Title V Core List is a list of rules to which all Title V Sources are presumptively subject. The Title V Core List may be referenced in its entirety, or with specific exceptions. The Department may periodically update the Title V Core List.]

Federal: (description)

40 CFR 61, Subpart M: NESHAP for Asbestos.

40 CFR 82: Protection of Stratospheric Ozone.

40 CFR 82, Subpart B: Servicing of Motor Vehicle Air Conditioners (MVAC).

40 CFR 82, Subpart F: Recycling and Emissions Reduction.

State: (description)**CHAPTER 62-4, F.A.C.: PERMITS, effective 03-16-08**

62-4.030, F.A.C.: General Prohibition.

62-4.040, F.A.C.: Exemptions.

62-4.050, F.A.C.: Procedure to Obtain Permits; Application.

62-4.060, F.A.C.: Consultation.

62-4.070, F.A.C.: Standards for Issuing or Denying Permits; Issuance; Denial.

62-4.080, F.A.C.: Modification of Permit Conditions.

62-4.090, F.A.C.: Renewals.

62-4.100, F.A.C.: Suspension and Revocation.

62-4.110, F.A.C.: Financial Responsibility.

62-4.120, F.A.C.: Transfer of Permits.

62-4.130, F.A.C.: Transferability of Definitions.

62-4.150, F.A.C.: Review.

62-4.160, F.A.C.: Permit Conditions.

62-4.210, F.A.C.: Construction Permits.

62-4.220, F.A.C.: Operation Permit for New Sources.

CHAPTER 62-210, F.A.C.: STATIONARY SOURCES - GENERAL REQUIREMENTS, effective 06-29-09

62-210.300, F.A.C.: Permits Required.

62-210.300(1), F.A.C.: Air Construction Permits.

62-210.300(2), F.A.C.: Air Operation Permits.

62-210.300(3), F.A.C.: Exemptions.

62-210.300(5), F.A.C.: Notification of Startup.

62-210.300(6), F.A.C.: Emissions Unit Reclassification.

62-210.300(7), F.A.C.: Transfer of Air Permits.

62-210.350, F.A.C.: Public Notice and Comment.

62-210.350(1), F.A.C.: Public Notice of Proposed Agency Action.

62-210.350(2), F.A.C.: Additional Public Notice Requirements for Emissions Units Subject to Prevention of Significant Deterioration or Nonattainment-Area Preconstruction Review.

62-210.350(3), F.A.C.: Additional Public Notice Requirements for Sources Subject to Operation Permits for Title V Sources.

62-210.360, F.A.C.: Administrative Permit Corrections.
62-210.370, F.A.C.: Emissions Computation and Reporting.
62-210.400, F.A.C.: Emission Estimates.
62-210.650, F.A.C.: Circumvention.
62-210.700, F.A.C.: Excess Emissions.

62-210.900, F.A.C.: Forms and Instructions.
62-210.900(1), F.A.C.: Application for Air Permit – Title V Source, Form and Instructions.
62-210.900(5), F.A.C.: Annual Operating Report for Air Pollutant Emitting Facility, Form and Instructions.
62-210.900(7), F.A.C.: Application for Transfer of Air Permit – Title V and Non-Title V Source.

CHAPTER 62-212, F.A.C.: STATIONARY SOURCES - PRECONSTRUCTION REVIEW, effective 06-29-09

CHAPTER 62-213, F.A.C.: OPERATION PERMITS FOR MAJOR SOURCES OF AIR POLLUTION, effective 10-12-08

62-213.205, F.A.C.: Annual Emissions Fee.
62-213.400, F.A.C.: Permits and Permit Revisions Required.
62-213.410, F.A.C.: Changes Without Permit Revision.
62-213.412, F.A.C.: Immediate Implementation Pending Revision Process.
62-213.415, F.A.C.: Trading of Emissions Within a Source.
62-213.420, F.A.C.: Permit Applications.
62-213.430, F.A.C.: Permit Issuance, Renewal, and Revision.
62-213.440, F.A.C.: Permit Content.
62-213.450, F.A.C.: Permit Review by EPA and Affected States
62-213.460, F.A.C.: Permit Shield.

62-213.900, F.A.C.: Forms and Instructions.
62-213.900(1), F.A.C.: Major Air Pollution Source Annual Emissions Fee Form.
62-213.900(7), F.A.C.: Statement of Compliance Form.

CHAPTER 62-296, F.A.C.: STATIONARY SOURCES - EMISSION STANDARDS, effective 10-06-08

62-296.320(4)(c), F.A.C.: Unconfined Emissions of Particulate Matter.

62-296.320(2), F.A.C.: Objectionable Odor Prohibited.

CHAPTER 62-297, F.A.C.: STATIONARY SOURCES - EMISSIONS MONITORING, effective 2-12-04

62-297.310, F.A.C.: General Test Requirements.
62-297.310(4), F.A.C.: Applicable Test Procedures.
62-297.310(7), F.A.C.: Frequency of Compliance Tests.
62-297.310(6), F.A.C.: Repaired Stack Sampling Facilities.
62-297.310(5), F.A.C.: Determination of Process Variables.
62-297.510(8), F.A.C.: Test Report.
62-297.620, F.A.C.: Exceptions and Approval of Alternate Procedures and Requirements.

Miscellaneous:

CHAPTER 28-106, F.A.C.: Decisions Determining Substantial Interests
CHAPTER 62-110, F.A.C.: Exception to the Uniform Rules of Procedure, effective 07-01-98
CHAPTER 62-256, F.A.C.: Open Burning and Frost Protection Fires, effective 10-06-08
CHAPTER 62-257, F.A.C.: Asbestos Notification and Fee, effective 10-12-08
CHAPTER 62-281, F.A.C.: Motor Vehicle Air Conditioning Refrigerant Recovery and Recycling, effective 09-10-96

ATTACHMENT BC-FI-CV3
COMPLIANCE REPORT AND PLAN

**ATTACHMENT BC-FI-CV3
COMPLIANCE REPORT**

Bay County certifies that the Bay Resource Management Center in Panama City, Florida, as of the date of this application, is in compliance with each applicable requirement addressed in this Title V air operation renewal permit application.

I, the undersigned, am the responsible official as designated in Chapter 62-213, F.A.C., of the Title V source for which this report is being submitted. I hereby certify, based on information and belief formed after reasonable inquiry, that the statements made and data contained in this report are true, accurate, and complete.

Compliance statements for this facility will be submitted on an annual basis to FDEP, on or before March 1 of each year.



Signature, Responsible Official

1-26-10

Date

EMISSIONS UNIT INFORMATION

Section [1]

MWC Unit No. 1 and No. 2

III. EMISSIONS UNIT INFORMATION

Title V Air Operation Permit Application – For Title V air operation permitting only, emissions units are classified as regulated, unregulated, or insignificant. If this is an application for an initial, revised or renewal Title V air operation permit, a separate Emissions Unit Information Section (including subsections A through I as required) must be completed for each regulated and unregulated emissions unit addressed in this application. Some of the subsections comprising the Emissions Unit Information Section of the form are optional for unregulated emissions units. Each such subsection is appropriately marked. Insignificant emissions units are required to be listed at Section II, Subsection C.

Air Construction Permit or FESOP Application – For air construction permitting or federally enforceable state air operation permitting, emissions units are classified as either subject to air permitting or exempt from air permitting. The concept of an “unregulated emissions unit” does not apply. If this is an application for an air construction permit or FESOP, a separate Emissions Unit Information Section (including subsections A through I as required) must be completed for each emissions unit subject to air permitting addressed in this application for air permit. Emissions units exempt from air permitting are required to be listed at Section II, Subsection C.

Air Construction Permit and Revised/Renewal Title V Air Operation Permit Application – Where this application is used to apply for both an air construction permit and a revised or renewal Title V air operation permit, each emissions unit is classified as either subject to air permitting or exempt from air permitting for air construction permitting purposes, and as regulated, unregulated, or insignificant for Title V air operation permitting purposes. A separate Emissions Unit Information Section (including subsections A through I as required) must be completed for each emissions unit addressed in this application that is subject to air construction permitting and for each such emissions unit that is a regulated or unregulated unit for purposes of Title V permitting. (An emissions unit may be exempt from air construction permitting but still be classified as an unregulated unit for Title V purposes.) Emissions units classified as insignificant for Title V purposes are required to be listed at Section II, Subsection C.

If submitting the application form in hard copy, the number of this Emissions Unit Information Section and the total number of Emissions Unit Information Sections submitted as part of this application must be indicated in the space provided at the top of each page.

EMISSIONS UNIT INFORMATION

Section [1]

MWC Unit No. 1 and No. 2

A. GENERAL EMISSIONS UNIT INFORMATION

Title V Air Operation Permit Emissions Unit Classification

1. Regulated or Unregulated Emissions Unit? (Check one, if applying for an initial, revised or renewal Title V air operation permit. Skip this item if applying for an air construction permit or FESOP only.)

The emissions unit addressed in this Emissions Unit Information Section is a regulated emissions unit.

The emissions unit addressed in this Emissions Unit Information Section is an unregulated emissions unit.

Emissions Unit Description and Status

1. Type of Emissions Unit Addressed in this Section: (Check one)

This Emissions Unit Information Section addresses, as a single emissions unit, a single process or production unit, or activity, which produces one or more air pollutants and which has at least one definable emission point (stack or vent).

This Emissions Unit Information Section addresses, as a single emissions unit, a group of process or production units and activities which has at least one definable emission point (stack or vent) but may also produce fugitive emissions.

This Emissions Unit Information Section addresses, as a single emissions unit, one or more process or production units and activities which produce fugitive emissions only.

2. Description of Emissions Unit Addressed in this Section:
MWC Unit No. 1 (North) and No. 2 (South).

3. Emissions Unit Identification Number: **001, 002**

4. Emissions Unit Status Code:
A

5. Commence Construction Date:
January 1986

6. Initial Startup Date:
May 1, 1987

7. Emissions Unit Major Group SIC Code:
49

8. Federal Program Applicability: (Check all that apply)

- Acid Rain Unit
- CAIR Unit
- Hg Budget Unit

9. Package Unit:
Manufacturer:

Model Number:

10. Generator Nameplate Rating: **15 MW**

11. Emissions Unit Comment:

Emission Units 001 and 002 are O'Connor Combustor mass burn rotary waterwall municipal waste combustors (MWCs) with a maximum individual charging rate that shall not exceed 255 tons per day of municipal solid waste (MSW) at 4,500 Btu/lb (a total of 510 tons per day for the facility; equivalent to 68,000 lb/hr steam per unit).

EMISSIONS UNIT INFORMATION

Section [1]

MWC Unit No. 1 and No. 2

Emissions Unit Control Equipment/Method: Control 1 of 3

- | |
|---|
| 1. Control Equipment/Method Description:
Fabric Filter – High Temperature (T > 250F) – 5 compartment, pulse jet and fiberglass bags.
Manufacturer: Merrick
Removal Efficiency: 99%+ particulate matter |
| 2. Control Device or Method Code: 016 |

Emissions Unit Control Equipment/Method: Control 2 of 3

- | |
|---|
| 1. Control Equipment/Method Description:
Spray Dryer – Downflow Spray Dryer Absorber – 5 dual fluid nozzles and calcium hydroxide lime slurry injection.
Manufacturer: Belco/Merrick
Removal Efficiency: >75% for sulfur dioxide and >95% for hydrogen chloride |
| 2. Control Device or Method Code: 202 |

Emissions Unit Control Equipment/Method: Control 3 of 3

- | |
|--|
| 1. Control Equipment/Method Description:
Carbon Injection – Powdered activated carbon with pneumatic injection upstream of absorber.
Manufacturer: Merrick
Removal Efficiency: >85% for mercury |
| 2. Control Device or Method Code: 207 |

Emissions Unit Control Equipment/Method: Control ____ of ____

- | |
|--|
| 1. Control Equipment/Method Description: |
| 2. Control Device or Method Code: |

EMISSIONS UNIT INFORMATION

**Section [1]
MWC Unit No. 1 and No. 2**

**B. EMISSIONS UNIT CAPACITY INFORMATION
(Optional for unregulated emissions units.)**

Emissions Unit Operating Capacity and Schedule

1. Maximum Process or Throughput Rate: 510 tons of MSW per day at 4,500 Btu/lb				
2. Maximum Production Rate: 136,000 lb/hr steam flow rate, 24 hr average				
3. Maximum Heat Input Rate: 191.25 million Btu/hr				
4. Maximum Incineration Rate: 42,500 pounds/hr 510 tons/day at 4,500 Btu/hr				
5. Requested Maximum Operating Schedule: <table><tr><td>24 hours/day</td><td>7 days/week</td></tr><tr><td>52 weeks/year</td><td>8,760 hours/year</td></tr></table>	24 hours/day	7 days/week	52 weeks/year	8,760 hours/year
24 hours/day	7 days/week			
52 weeks/year	8,760 hours/year			
6. Operating Capacity/Schedule Comment: Maximum process rate for each unit is 255 tons of MSW per day at 4,500 Btu/lb. Maximum production rate for each unit is 68,000 lb/hr steam flow rate, 24-hr average. Maximum heat input rate for each unit is 95.6 MMBtu/hr, 24-hour average based on 255 TPD MSW and 4,500 Btu/lb. Maximum 4-hour average rates for each unit are as follows, based on 110% of 24-hour average: 11.7 TPH MSW 74,800 lb/hr steam 105.2 MMBtu/hr				

EMISSIONS UNIT INFORMATION

Section [1]

MWC Unit No. 1 and No. 2

C. EMISSION POINT (STACK/VENT) INFORMATION

(Optional for unregulated emissions units.)

Emission Point Description and Type

1. Identification of Point on Plot Plan or Flow Diagram: MWC Unit 1 North Stack MWC Unit 2 South Stack		2. Emission Point Type Code: 3	
3. Descriptions of Emission Points Comprising this Emissions Unit for VE Tracking: MWC Unit No. 1 (North) MWC Unit No. 2 (South)			
4. ID Numbers or Descriptions of Emission Units with this Emission Point in Common:			
5. Discharge Type Code: V	6. Stack Height: 141 feet	7. Exit Diameter: 5 feet	
8. Exit Temperature: 290°F	9. Actual Volumetric Flow Rate: 75,000 acfm	10. Water Vapor: 16.5 %	
11. Maximum Dry Standard Flow Rate: 32,426 dscfm		12. Nonstack Emission Point Height: feet	
13. Emission Point UTM Coordinates... Zone: East (km): North (km):		14. Emission Point Latitude/Longitude... Latitude (DD/MM/SS) Longitude (DD/MM/SS)	
15. Emission Point Comment: Stack parameters are for each boiler, representative of 24-hour operating rate. Maximum dry standard flow rate corrected to 7% O₂. Maximum 1-hour stack gas flow rate is 35,669 dscfm at 7% O₂, based on 105.2 MMBtu/hr and highest stack test flow rate, 2005-2009.			

EMISSIONS UNIT INFORMATION

Section [1]

MWC Unit No. 1 and No. 2

D. SEGMENT (PROCESS/FUEL) INFORMATION

Segment Description and Rate: Segment 1 of 3

1. Segment Description (Process/Fuel Type): External Combustion Boilers; Electrical Generation; Natural Gas; Boilers < 100 Million Btu/hr except Tangential.		
2. Source Classification Code (SCC): 1-01-006-02		3. SCC Units: Million Cubic Feet Natural Gas
4. Maximum Hourly Rate:	5. Maximum Annual Rate: 50	6. Estimated Annual Activity Factor:
7. Maximum % Sulfur:	8. Maximum % Ash:	9. Million Btu per SCC Unit: 1,050
10. Segment Comment: Natural Gas is used in the auxiliary burner during startup for the introduction of MSW. Maximum annual rate based on 2008 natural gas use. Usage varies by unit and year depending on the number of startups and shutdowns.		

Segment Description and Rate: Segment 2 of 3

1. Segment Description (Process/Fuel Type): External Combustion Boilers; Electrical Generation; Wood/Bark Waste; Wood/Bark Boiler		
2. Source Classification Code (SCC): 1-01-009-02		3. SCC Units: Tons Wood/Bark Burned
4. Maximum Hourly Rate: 19.13	5. Maximum Annual Rate: 58,400	6. Estimated Annual Activity Factor:
7. Maximum % Sulfur:	8. Maximum % Ash: 0.4	9. Million Btu per SCC Unit: 11
10. Segment Comment: Maximum hourly based on heat input per unit of 105.2 MMBtu/hr. Maximum annual based on permit limit of 160 TPD for the facility.		

EMISSIONS UNIT INFORMATION

Section [1]

MWC Unit No. 1 and No. 2

D. SEGMENT (PROCESS/FUEL) INFORMATION (CONTINUED)

Segment Description and Rate: Segment 3 of 3

1. Segment Description (Process/Fuel Type): External Combustion Boilers; Electrical Generation; Solid Waste; Municipal Solid Waste.		
2. Source Classification Code (SCC): 1-01-012-01		3. SCC Units: Tons Burned
4. Maximum Hourly Rate: 23.38	5. Maximum Annual Rate: 186,150	6. Estimated Annual Activity Factor:
7. Maximum % Sulfur: 0.16	8. Maximum % Ash: 28	9. Million Btu per SCC Unit: 9
10. Segment Comment: Maximum rates total both units. Maximum hourly based on 105.2 MMBtu/hr for each unit. Maximum annual rates based on 255 TPD MSW per unit at 4,500 Btu/hr.		

Segment Description and Rate: Segment ____ of ____

1. Segment Description (Process/Fuel Type):		
2. Source Classification Code (SCC):		3. SCC Units:
4. Maximum Hourly Rate:	5. Maximum Annual Rate:	6. Estimated Annual Activity Factor:
7. Maximum % Sulfur:	8. Maximum % Ash:	9. Million Btu per SCC Unit:
10. Segment Comment:		

EMISSIONS UNIT INFORMATION

Section [1]

MWC Unit No. 1 and No. 2

E. EMISSIONS UNIT POLLUTANTS**List of Pollutants Emitted by Emissions Unit**

1. Pollutant Emitted	2. Primary Control Device Code	3. Secondary Control Device Code	4. Pollutant Regulatory Code
PM	016	202	EL
PM10	016	202	NS
PM2.5	016	202	NS
H027 – Cadmium	202	016	EL
PB – Lead	202	016	EL
NOx			EL
CO			EL
D/F – Dioxin/Furan	207	016	EL
SO2	202	016	EL
H106 – Hydrogen Chloride	202	016	EL
H114 – Mercury	207	016	EL
FL	202	016	EL
H021 – Beryllium	202	016	NS
SAM – Sulfuric Acid Mist	202	016	EL
VOC			EL
HAPs – Total HAPs			NS

EMISSIONS UNIT INFORMATION

Section [1]
MWC Unit No. 1 and No. 2

POLLUTANT DETAIL INFORMATION

Page [1] of [14]
PM – Particulate Matter

**F1. EMISSIONS UNIT POLLUTANT DETAIL INFORMATION –
POTENTIAL, FUGITIVE, AND ACTUAL EMISSIONS**

(Optional for unregulated emissions units.)

Complete a Subsection F1 for each pollutant identified in Subsection E if applying for an air construction permit or concurrent processing of an air construction permit and a revised or renewal Title V operation permit. Complete for each emissions-limited pollutant identified in Subsection E if applying for an air operation permit.

Potential, Estimated Fugitive, and Baseline & Projected Actual Emissions

1. Pollutant Emitted: PM		2. Total Percent Efficiency of Control:	
3. Potential Emissions: 6.68 lb/hour 26.60 tons/year		4. Synthetically Limited? <input type="checkbox"/> Yes <input checked="" type="checkbox"/> No	
5. Range of Estimated Fugitive Emissions (as applicable): to tons/year			
6. Emission Factor: 25 mg/dscm at 7 percent O₂ Reference: 40 CFR 60, Subpart Cb		7. Emissions Method Code: 0	
8.a. Baseline Actual Emissions (if required): 16.84 tons/year		8.b. Baseline 24-month Period: From: January 2002 To: December 2003	
9.a. Projected Actual Emissions (if required): 17.52 tons/year		9.b. Projected Monitoring Period: <input type="checkbox"/> 5 years <input checked="" type="checkbox"/> 10 years	
10. Calculation of Emissions: Per unit hourly: 25 mg/dscm x m³/35.32 cf x 35,669 dscf/min x g/1,000 mg x lb/453.6 g x 60 min/hr = 3.34 lb/hr Per unit 24-hourly: 25 mg/dscm x m³/35.32 cf x 32,426 dscf/min x g/1,000 mg x lb/453.6 g x 60 min/hr = 3.04 lb/hr Per unit annually: 3.04 lb/hr x 8,760 hr/yr x ton/2,000 lb = 13.30 TPY See Attachment BC-EU1-F1.10.			
11. Potential, Fugitive, and Actual Emissions Comment: Emissions represent total for both boilers.			

EMISSIONS UNIT INFORMATION

POLLUTANT DETAIL INFORMATION

Section [1]
MWC Unit No. 1 and No. 2

Page [1] of [14]
PM – Particulate Matter

**F2. EMISSIONS UNIT POLLUTANT DETAIL INFORMATION -
ALLOWABLE EMISSIONS**

Complete Subsection F2 if the pollutant identified in Subsection F1 is or would be subject to a numerical emissions limitation.

Allowable Emissions Allowable Emissions 1 of 2

1. Basis for Allowable Emissions Code: RULE	2. Future Effective Date of Allowable Emissions: Upon Approval of Application
3. Allowable Emissions and Units: 25 mg/dscm, corrected to 7 percent O₂	4. Equivalent Allowable Emissions: 6.68 lb/hour 26.60 tons/year
5. Method of Compliance: Annual Compliance Test and Continous Opacity Monitor (COMs) EPA Method 5.	
6. Allowable Emissions Comment (Description of Operating Method): Based on 40 CFR 60, Subpart Cb Represents total of both boilers.	

Allowable Emissions Allowable Emissions 2 of 2

1. Basis for Allowable Emissions Code: RULE	2. Future Effective Date of Allowable Emissions:
3. Allowable Emissions and Units: 27 mg/dscm, corrected to 7 percent O₂	4. Equivalent Allowable Emissions: 6.43 lb/hour 27.60 tons/year
5. Method of Compliance: Annual Compliance Test and Continous Opacity Monitor (COMs) EPA Method 5.	
6. Allowable Emissions Comment (Description of Operating Method): Based on 40 CFR 60, Subpart BBBB Represents total of both boilers.	

Allowable Emissions Allowable Emissions of

1. Basis for Allowable Emissions Code:	2. Future Effective Date of Allowable Emissions:
3. Allowable Emissions and Units:	4. Equivalent Allowable Emissions: lb/hour tons/year
5. Method of Compliance:	
6. Allowable Emissions Comment (Description of Operating Method):	

EMISSIONS UNIT INFORMATION

POLLUTANT DETAIL INFORMATION

Section [1]
MWC Unit No. 1 and No. 2

Page [2] of [14]
Particulate Matter – PM10

**F1. EMISSIONS UNIT POLLUTANT DETAIL INFORMATION –
POTENTIAL, FUGITIVE, AND ACTUAL EMISSIONS**

(Optional for unregulated emissions units.)

Complete a Subsection F1 for each pollutant identified in Subsection E if applying for an air construction permit or concurrent processing of an air construction permit and a revised or renewal Title V operation permit. Complete for each emissions-limited pollutant identified in Subsection E if applying for an air operation permit.

Potential, Estimated Fugitive, and Baseline & Projected Actual Emissions

1. Pollutant Emitted: PM10		2. Total Percent Efficiency of Control:	
3. Potential Emissions: 3.61 lb/hour 14.36 tons/year		4. Synthetically Limited? <input type="checkbox"/> Yes <input checked="" type="checkbox"/> No	
5. Range of Estimated Fugitive Emissions (as applicable): to tons/year			
6. Emission Factor: 54 % of PM Reference: Based on EPA PM calculator		7. Emissions Method Code: 5	
8.a. Baseline Actual Emissions (if required): 9.10 tons/year		8.b. Baseline 24-month Period: From: January 2002 To: December 2003	
9.a. Projected Actual Emissions (if required): 9.54 tons/year		9.b. Projected Monitoring Period: <input type="checkbox"/> 5 years <input checked="" type="checkbox"/> 10 years	
10. Calculation of Emissions: PM₁₀ is 54 percent of PM emissions.			
11. Potential, Fugitive, and Actual Emissions Comment: Emissions represent total for both boilers.			

EMISSIONS UNIT INFORMATIONSection [1]
MWC Unit No. 1 and No. 2**POLLUTANT DETAIL INFORMATION**Page [2] of [14]
Particulate Matter – PM10**F2. EMISSIONS UNIT POLLUTANT DETAIL INFORMATION -
ALLOWABLE EMISSIONS****Complete Subsection F2 if the pollutant identified in Subsection F1 is or would be subject to a numerical emissions limitation.****Allowable Emissions** Allowable Emissions _____ of _____

1. Basis for Allowable Emissions Code:	2. Future Effective Date of Allowable Emissions:
3. Allowable Emissions and Units:	4. Equivalent Allowable Emissions: lb/hour tons/year
5. Method of Compliance:	
6. Allowable Emissions Comment (Description of Operating Method):	

Allowable Emissions Allowable Emissions _____ of _____

1. Basis for Allowable Emissions Code:	2. Future Effective Date of Allowable Emissions:
3. Allowable Emissions and Units:	4. Equivalent Allowable Emissions: lb/hour tons/year
5. Method of Compliance:	
6. Allowable Emissions Comment (Description of Operating Method):	

Allowable Emissions Allowable Emissions _____ of _____

1. Basis for Allowable Emissions Code:	2. Future Effective Date of Allowable Emissions:
3. Allowable Emissions and Units:	4. Equivalent Allowable Emissions: lb/hour tons/year
5. Method of Compliance:	
6. Allowable Emissions Comment (Description of Operating Method):	

EMISSIONS UNIT INFORMATION

POLLUTANT DETAIL INFORMATION

Section [1]
MWC Unit No. 1 and No. 2

Page [3] of [14]
Particulate Matter – PM2.5

**F1. EMISSIONS UNIT POLLUTANT DETAIL INFORMATION –
POTENTIAL, FUGITIVE, AND ACTUAL EMISSIONS**

(Optional for unregulated emissions units.)

Complete a Subsection F1 for each pollutant identified in Subsection E if applying for an air construction permit or concurrent processing of an air construction permit and a revised or renewal Title V operation permit. Complete for each emissions-limited pollutant identified in Subsection E if applying for an air operation permit.

Potential, Estimated Fugitive, and Baseline & Projected Actual Emissions

1. Pollutant Emitted: PM2.5		2. Total Percent Efficiency of Control:	
3. Potential Emissions: 2.61 lb/hour 10.37 tons/year		4. Synthetically Limited? <input type="checkbox"/> Yes <input checked="" type="checkbox"/> No	
5. Range of Estimated Fugitive Emissions (as applicable): to tons/year			
6. Emission Factor: 39% of PM emissions Reference: EPA PM calculator		7. Emissions Method Code: 5	
8.a. Baseline Actual Emissions (if required): 6.58 tons/year		8.b. Baseline 24-month Period: From: January 2002 To: December 2003	
9.a. Projected Actual Emissions (if required): 6.93 tons/year		9.b. Projected Monitoring Period: <input type="checkbox"/> 5 years <input checked="" type="checkbox"/> 10 years	
10. Calculation of Emissions: PM_{2.5} is 39% of PM emissions.			
11. Potential, Fugitive, and Actual Emissions Comment: Emissions represent total for both boilers.			

EMISSIONS UNIT INFORMATION

Section [1]
MWC Unit No. 1 and No. 2

POLLUTANT DETAIL INFORMATION

Page [3] of [14]
Particulate Matter – PM2.5

**F2. EMISSIONS UNIT POLLUTANT DETAIL INFORMATION -
ALLOWABLE EMISSIONS**

Complete Subsection F2 if the pollutant identified in Subsection F1 is or would be subject to a numerical emissions limitation.

Allowable Emissions Allowable Emissions ____ of ____

1. Basis for Allowable Emissions Code:	2. Future Effective Date of Allowable Emissions:
3. Allowable Emissions and Units:	4. Equivalent Allowable Emissions: lb/hour tons/year
5. Method of Compliance:	
6. Allowable Emissions Comment (Description of Operating Method):	

Allowable Emissions Allowable Emissions ____ of ____

1. Basis for Allowable Emissions Code:	2. Future Effective Date of Allowable Emissions:
3. Allowable Emissions and Units:	4. Equivalent Allowable Emissions: lb/hour tons/year
5. Method of Compliance:	
6. Allowable Emissions Comment (Description of Operating Method):	

Allowable Emissions Allowable Emissions ____ of ____

1. Basis for Allowable Emissions Code:	2. Future Effective Date of Allowable Emissions:
3. Allowable Emissions and Units:	4. Equivalent Allowable Emissions: lb/hour tons/year
5. Method of Compliance:	
6. Allowable Emissions Comment (Description of Operating Method):	

EMISSIONS UNIT INFORMATION

POLLUTANT DETAIL INFORMATION

Section [1]
MWC Unit No. 1 and No. 2

Page [4] of [14]
Cadmium – H027

**F1. EMISSIONS UNIT POLLUTANT DETAIL INFORMATION –
POTENTIAL, FUGITIVE, AND ACTUAL EMISSIONS**

(Optional for unregulated emissions units.)

Complete a Subsection F1 for each pollutant identified in Subsection E if applying for an air construction permit or concurrent processing of an air construction permit and a revised or renewal Title V operation permit. Complete for each emissions-limited pollutant identified in Subsection E if applying for an air operation permit.

Potential, Estimated Fugitive, and Baseline & Projected Actual Emissions

1. Pollutant Emitted: Cadmium – H027		2. Total Percent Efficiency of Control:	
3. Potential Emissions: 0.0094 lb/hour 0.0372 tons/year		4. Synthetically Limited? <input type="checkbox"/> Yes <input checked="" type="checkbox"/> No	
5. Range of Estimated Fugitive Emissions (as applicable): to tons/year			
6. Emission Factor: 35 µg/dscm at 7 percent O₂ Reference: 40 CFR 60, Subpart Cb		7. Emissions Method Code: 0	
8.a. Baseline Actual Emissions (if required): tons/year		8.b. Baseline 24-month Period: From: To:	
9.a. Projected Actual Emissions (if required): tons/year		9.b. Projected Monitoring Period: <input type="checkbox"/> 5 years <input type="checkbox"/> 10 years	
10. Calculation of Emissions: Per unit hourly: $35 \mu\text{g/dscm} \times \text{m}^3/35.32 \text{ cf} \times 35,669 \text{ dscf/min} \times \text{g}/10^6 \mu\text{g} \times \text{lb}/453.6 \text{ g} \times 60 \text{ min/hr} = 0.00468 \text{ lb/hr}$ Per unit 24-hourly: $35 \mu\text{g/dscm} \times \text{m}^3/35.32 \text{ cf} \times 32,426 \text{ dscf/min} \times \text{g}/10^6 \mu\text{g} \times \text{lb}/453.6 \text{ g} \times 60 \text{ min/hr} = 0.00425 \text{ lb/hr}$ Per unit annually: $0.00425 \text{ lb/hr} \times 8,760 \text{ hr/yr} \times \text{ton}/2,000 \text{ lb} = 0.0186 \text{ TPY}$ See Attachment BC-EU1-F1.10.			
11. Potential, Fugitive, and Actual Emissions Comment: Emissions represent total for both boilers.			

EMISSIONS UNIT INFORMATION

Section [1]
MWC Unit No. 1 and No. 2

POLLUTANT DETAIL INFORMATION

Page [4] of [14]
Cadmium - H027

**F2. EMISSIONS UNIT POLLUTANT DETAIL INFORMATION -
ALLOWABLE EMISSIONS**

Complete Subsection F2 if the pollutant identified in Subsection F1 is or would be subject to a numerical emissions limitation.

Allowable Emissions Allowable Emissions 1 of 2

1. Basis for Allowable Emissions Code: RULE	2. Future Effective Date of Allowable Emissions: Upon Approval of Application
3. Allowable Emissions and Units: 35 µg/dscm, corrected to 7 percent O₂	4. Equivalent Allowable Emissions: 0.0094 lb/hour 0.0372 tons/year
5. Method of Compliance: EPA Method 29 Annual Compliance Test.	
6. Allowable Emissions Comment (Description of Operating Method): Based on 40 CFR 60, Subpart Cb Represents total of both boilers.	

Allowable Emissions Allowable Emissions 2 of 2

1. Basis for Allowable Emissions Code: RULE	2. Future Effective Date of Allowable Emissions:
3. Allowable Emissions and Units: 40 µg/dscm, corrected to 7 percent O₂	4. Equivalent Allowable Emissions: 0.0095 lb/hour 0.0409 tons/year
5. Method of Compliance: EPA Method 29 Annual Compliance Test.	
6. Allowable Emissions Comment (Description of Operating Method): Based on 40 CFR 60, Subpart BBBB Represents total of both boilers.	

Allowable Emissions Allowable Emissions ____ of ____

1. Basis for Allowable Emissions Code:	2. Future Effective Date of Allowable Emissions:
3. Allowable Emissions and Units:	4. Equivalent Allowable Emissions: lb/hour tons/year
5. Method of Compliance:	
6. Allowable Emissions Comment (Description of Operating Method):	

EMISSIONS UNIT INFORMATION

POLLUTANT DETAIL INFORMATION

Section [1]
MWC Unit No. 1 and No. 2

Page [5] of [14]
Lead - Pb

**F1. EMISSIONS UNIT POLLUTANT DETAIL INFORMATION -
POTENTIAL, FUGITIVE, AND ACTUAL EMISSIONS**

(Optional for unregulated emissions units.)

Complete a Subsection F1 for each pollutant identified in Subsection E if applying for an air construction permit or concurrent processing of an air construction permit and a revised or renewal Title V operation permit. Complete for each emissions-limited pollutant identified in Subsection E if applying for an air operation permit.

Potential, Estimated Fugitive, and Baseline & Projected Actual Emissions

1. Pollutant Emitted: Lead - Pb		2. Total Percent Efficiency of Control:	
3. Potential Emissions: 0.107 lb/hour 0.43 tons/year		4. Synthetically Limited? <input type="checkbox"/> Yes <input checked="" type="checkbox"/> No	
5. Range of Estimated Fugitive Emissions (as applicable): to tons/year			
6. Emission Factor: 400 µg/dscm, 7 percent O₂ Reference: 40 CFR 60, Subpart Cb		7. Emissions Method Code: 0	
8.a. Baseline Actual Emissions (if required): 0.32 tons/year		8.b. Baseline 24-month Period: From: January 2002 To: December 2003	
9.a. Projected Actual Emissions (if required): 0.025 tons/year		9.b. Projected Monitoring Period: <input type="checkbox"/> 5 years <input checked="" type="checkbox"/> 10 years	
10. Calculation of Emissions: Per unit hourly: $400 \mu\text{g/dscm} \times \text{m}^3/35.32 \text{ cf} \times 35,669 \text{ dscf/min} \times \text{g}/1,000,000 \mu\text{g} \times \text{lb}/453.6 \text{ g} \times 60 \text{ min/hr} = 0.053 \text{ lb/hr}$ Per unit 24-hourly: $400 \mu\text{g/dscm} \times \text{m}^3/35.32 \text{ cf} \times 32,426 \text{ dscf/min} \times \text{g}/1,000,000 \mu\text{g} \times \text{lb}/453.6 \text{ g} \times 60 \text{ min/hr} = 0.0486 \text{ lb/hr}$ Per unit annually: $0.0486 \text{ lb/hr} \times 8,760 \text{ hr/yr} \times \text{ton}/2,000 \text{ lb} = 0.43 \text{ TPY}$ See Attachment BC-EU1-F1.10.			
11. Potential, Fugitive, and Actual Emissions Comment: Emissions represent total for both boilers.			

EMISSIONS UNIT INFORMATION

POLLUTANT DETAIL INFORMATION

Section [1]
MWC Unit No. 1 and No. 2

Page [5] of [14]
Lead - Pb

**F2. EMISSIONS UNIT POLLUTANT DETAIL INFORMATION -
ALLOWABLE EMISSIONS**

Complete Subsection F2 if the pollutant identified in Subsection F1 is or would be subject to a numerical emissions limitation.

Allowable Emissions Allowable Emissions 1 of 2

1. Basis for Allowable Emissions Code: RULE	2. Future Effective Date of Allowable Emissions: Upon Approval of Application
3. Allowable Emissions and Units: 400 µg/dscm, corrected to 7 percent O₂	4. Equivalent Allowable Emissions: 0.107 lb/hour 0.43 tons/year
5. Method of Compliance: EPA Method 29 Annual Compliance Test.	
6. Allowable Emissions Comment (Description of Operating Method): Based on 40 CFR 60, Subpart Cb Represents total of both boilers.	

Allowable Emissions Allowable Emissions 2 of 2

1. Basis for Allowable Emissions Code: RULE	2. Future Effective Date of Allowable Emissions:
3. Allowable Emissions and Units: 490 µg/dscm, corrected to 7 percent O₂	4. Equivalent Allowable Emissions: 0.117 lb/hour 0.50 tons/year
5. Method of Compliance: EPA Method 29 Annual Compliance Test.	
6. Allowable Emissions Comment (Description of Operating Method): Based on 40 CFR 60, Subpart BBBB Represents total of both boilers.	

Allowable Emissions Allowable Emissions ____ of ____

1. Basis for Allowable Emissions Code:	2. Future Effective Date of Allowable Emissions:
3. Allowable Emissions and Units:	4. Equivalent Allowable Emissions: lb/hour tons/year
5. Method of Compliance:	
6. Allowable Emissions Comment (Description of Operating Method):	

EMISSIONS UNIT INFORMATION

Section [1]
MWC Unit No. 1 and No. 2

POLLUTANT DETAIL INFORMATION

Page [6] of [14]
Nitrogen Oxides – NOx

**F1. EMISSIONS UNIT POLLUTANT DETAIL INFORMATION –
POTENTIAL, FUGITIVE, AND ACTUAL EMISSIONS**

(Optional for unregulated emissions units.)

Complete a Subsection F1 for each pollutant identified in Subsection E if applying for an air construction permit or concurrent processing of an air construction permit and a revised or renewal Title V operation permit. Complete for each emissions-limited pollutant identified in Subsection E if applying for an air operation permit.

Potential, Estimated Fugitive, and Baseline & Projected Actual Emissions

1. Pollutant Emitted: Nitrogen Oxides – NOx		2. Total Percent Efficiency of Control:	
3. Potential Emissions: 204.4 lb/hour 427.30 tons/year		4. Synthetically Limited? <input type="checkbox"/> Yes <input checked="" type="checkbox"/> No	
5. Range of Estimated Fugitive Emissions (as applicable): to tons/year			
6. Emission Factor: 210 ppmvd at 7 percent O₂ Reference: 40 CFR 60, Subpart Cb		7. Emissions Method Code: 0	
8.a. Baseline Actual Emissions (if required): 163.67 tons/year		8.b. Baseline 24-month Period: From: January 2002 To: December 2003	
9.a. Projected Actual Emissions (if required): 186.24 tons/year		9.b. Projected Monitoring Period: <input type="checkbox"/> 5 years <input checked="" type="checkbox"/> 10 years	
10. Calculation of Emissions: Per unit hourly: $400 \text{ ppmvd}/10^6 \times 2,116.8 \text{ lb}_r/\text{ft}^2 \times 60 \text{ min/hr} \times 35,669 \text{ dscf/min} \times 46 \text{ lb}_m\text{-}^{\circ}\text{R}/1,545.6 \text{ ft-lb}_r \times 1/(68+460)^{\circ}\text{R} = 102.18 \text{ lb/hr}$ Per unit hourly: $210 \text{ ppmvd}/10^6 \times 2,116.8 \text{ lb}_r/\text{ft}^2 \times 60 \text{ min/hr} \times 32,426 \text{ dscf/min} \times 46 \text{ lb}_m\text{-}^{\circ}\text{R}/1,545.6 \text{ ft-lb}_r \times 1/(68+460)^{\circ}\text{R} = 48.78 \text{ lb/hr}$ Per unit annually: $48.78 \text{ lb/hr} \times 8,760 \text{ hr/yr} \times \text{ton}/2,000 \text{ lb} = 213.7 \text{ TPY}$ See Attachment BC-EU1-F1.10.			
11. Potential, Fugitive, and Actual Emissions Comment: Emissions represent total for both boilers. The hourly potential emissions are based on historical CEMS data.			

EMISSIONS UNIT INFORMATION

POLLUTANT DETAIL INFORMATION

Section [1]
MWC Unit No. 1 and No. 2

Page [6] of [14]
Nitrogen Oxides - NOx

**F2. EMISSIONS UNIT POLLUTANT DETAIL INFORMATION -
ALLOWABLE EMISSIONS**

Complete Subsection F2 if the pollutant identified in Subsection F1 is or would be subject to a numerical emissions limitation.

Allowable Emissions Allowable Emissions 1 of 2

1. Basis for Allowable Emissions Code: RULE	2. Future Effective Date of Allowable Emissions: Upon Approval of Application
3. Allowable Emissions and Units: 210 ppmvd, corrected to 7 percent O₂	4. Equivalent Allowable Emissions: 204.4 lb/hour 427.30 tons/year
5. Method of Compliance: Continuous Emissions Monitoring System (CEMs)	
6. Allowable Emissions Comment (Description of Operating Method): Based on 40 CFR 60, Subpart Cb Represents total of both boilers.	

Allowable Emissions Allowable Emissions 2 of 2

1. Basis for Allowable Emissions Code: RULE	2. Future Effective Date of Allowable Emissions:
3. Allowable Emissions and Units: 170 ppmvd, corrected to 7 percent O₂	4. Equivalent Allowable Emissions: 182.1 lb/hour 332.35 tons/year
5. Method of Compliance: Continuous Emissions Monitoring System (CEMs)	
6. Allowable Emissions Comment (Description of Operating Method): Based on 40 CFR 60, Subpart BBBB Represents total of both boilers.	

Allowable Emissions Allowable Emissions _____ of _____

1. Basis for Allowable Emissions Code:	2. Future Effective Date of Allowable Emissions:
3. Allowable Emissions and Units:	4. Equivalent Allowable Emissions: lb/hour tons/year
5. Method of Compliance:	
6. Allowable Emissions Comment (Description of Operating Method):	

EMISSIONS UNIT INFORMATION

POLLUTANT DETAIL INFORMATION

Section [1]
MWC Unit No. 1 and No. 2

Page [7] of [14]
Carbon Monoxide – CO

**F1. EMISSIONS UNIT POLLUTANT DETAIL INFORMATION –
POTENTIAL, FUGITIVE, AND ACTUAL EMISSIONS**

(Optional for unregulated emissions units.)

Complete a Subsection F1 for each pollutant identified in Subsection E if applying for an air construction permit or concurrent processing of an air construction permit and a revised or renewal Title V operation permit. Complete for each emissions-limited pollutant identified in Subsection E if applying for an air operation permit.

Potential, Estimated Fugitive, and Baseline & Projected Actual Emissions

1. Pollutant Emitted: Carbon Monoxide – CO		2. Total Percent Efficiency of Control:	
3. Potential Emissions: 311.0 lb/hour 309.57 tons/year		4. Synthetically Limited? <input type="checkbox"/> Yes <input checked="" type="checkbox"/> No	
5. Range of Estimated Fugitive Emissions (as applicable): to tons/year			
6. Emission Factor: 250 ppmvd, 24 hour average at 7 percent O₂ Reference: 40 CFR 60, Subpart Cb		7. Emissions Method Code: 0	
8.a. Baseline Actual Emissions (if required): 169.2 tons/year		8.b. Baseline 24-month Period: From: January 2002 To: December 2003	
9.a. Projected Actual Emissions (if required): 173.53 tons/year		9.b. Projected Monitoring Period: <input type="checkbox"/> 5 years <input checked="" type="checkbox"/> 10 years	
10. Calculation of Emissions: Per unit hourly: $1,000 \text{ ppmvd}/10^6 \times 2,116.8 \text{ lb}_r/\text{ft}^2 \times 60 \text{ min/hr} \times 35,669 \text{ dscf/min} \times 28 \text{ lb}_m\text{-}^*R/1,545.6 \text{ ft-lb}_r \times 1/(68+460)^*R = 155.49$ Per unit hourly: $250 \text{ ppmvd}/10^6 \times 2,116.8 \text{ lb}_r/\text{ft}^2 \times 60 \text{ min/hr} \times 32,426 \text{ dscf/min} \times 28 \text{ lb}_m\text{-}^*R/1,545.6 \text{ ft-lb}_r \times 1/(68+460)^*R = 35.34 \text{ lb/hr}$ Per unit annually: $35.34 \text{ lb/hr} \times 8,760 \text{ hr/yr} \times \text{ton}/2,000 \text{ lb} = 154.8 \text{ TPY}$ See Attachment BC-EU1-F1.10.			
11. Potential, Fugitive, and Actual Emissions Comment: Emissions represent total for both boilers. The hourly potential emissions are based on historical CEMS data.			

EMISSIONS UNIT INFORMATION

POLLUTANT DETAIL INFORMATION

Section [1]
MWC Unit No. 1 and No. 2

Page [7] of [14]
Carbon Monoxide - CO

**F2. EMISSIONS UNIT POLLUTANT DETAIL INFORMATION -
ALLOWABLE EMISSIONS**

Complete Subsection F2 if the pollutant identified in Subsection F1 is or would be subject to a numerical emissions limitation.

Allowable Emissions Allowable Emissions 1 of 2

1. Basis for Allowable Emissions Code: RULE	2. Future Effective Date of Allowable Emissions: Upon Approval of Application
3. Allowable Emissions and Units: 250 ppmvd, 24 hour average, corrected to 7 percent O₂	4. Equivalent Allowable Emissions: 311.0 lb/hour 309.57 tons/year
5. Method of Compliance: Continuous Emissions Monitoring System (CEMs)	
6. Allowable Emissions Comment (Description of Operating Method): Based on 40 CFR 60, Subpart Cb Represents total of both boilers.	

Allowable Emissions Allowable Emissions 2 of 2

1. Basis for Allowable Emissions Code: RULE	2. Future Effective Date of Allowable Emissions:
3. Allowable Emissions and Units: 250 ppmvd, corrected to 7 percent O₂	4. Equivalent Allowable Emissions: 277.2 lb/hour 297.43 tons/year
5. Method of Compliance: Continuous Emissions Monitoring System (CEMs)	
6. Allowable Emissions Comment (Description of Operating Method): Based on 40 CFR 60, Subpart BBBB Represents total of both boilers.	

Allowable Emissions Allowable Emissions ____ of ____

1. Basis for Allowable Emissions Code:	2. Future Effective Date of Allowable Emissions:
3. Allowable Emissions and Units:	4. Equivalent Allowable Emissions: lb/hour tons/year
5. Method of Compliance:	
6. Allowable Emissions Comment (Description of Operating Method):	

EMISSIONS UNIT INFORMATION

POLLUTANT DETAIL INFORMATION

Section [1]
MWC Unit No. 1 and No. 2

Page [8] of [14]
Dioxin/Furan - D/F

**F1. EMISSIONS UNIT POLLUTANT DETAIL INFORMATION -
POTENTIAL, FUGITIVE, AND ACTUAL EMISSIONS**

(Optional for unregulated emissions units.)

Complete a Subsection F1 for each pollutant identified in Subsection E if applying for an air construction permit or concurrent processing of an air construction permit and a revised or renewal Title V operation permit. Complete for each emissions-limited pollutant identified in Subsection E if applying for an air operation permit.

Potential, Estimated Fugitive, and Baseline & Projected Actual Emissions

1. Pollutant Emitted: Dioxin/Furan - D/F		2. Total Percent Efficiency of Control:	
3. Potential Emissions: 8.02x10 ⁻⁶ lb/hour 3.19x10 ⁻⁵ tons/year		4. Synthetically Limited? <input type="checkbox"/> Yes <input checked="" type="checkbox"/> No	
5. Range of Estimated Fugitive Emissions (as applicable): to tons/year			
6. Emission Factor: 30 ng/dscm at 7 percent O ₂ Reference: 40 CFR 60, Subpart Cb		7. Emissions Method Code: 0	
8.a. Baseline Actual Emissions (if required): 2.21x10 ⁻⁵ tons/year		8.b. Baseline 24-month Period: From: January 2002 To: December 2003	
9.a. Projected Actual Emissions (if required): 2.21x10 ⁻⁵ tons/year		9.b. Projected Monitoring Period: <input type="checkbox"/> 5 years <input checked="" type="checkbox"/> 10 years	
10. Calculation of Emissions: Per unit hourly: 30 ng/dscm x m ³ /35.32 cf x 35,669 dscf/min x g/10 ⁹ ng x lb/453.6 g x 60 min/hr = 4.01x10 ⁻⁶ lb/hr Per unit 24-hourly: 30 ng/dscm x m ³ /35.32 cf x 32,426 dscf/min x g/10 ⁹ ng x lb/453.6 g x 60 min/hr = 3.64x10 ⁻⁶ lb/hr Per unit annually: 3.64x10 ⁻⁶ lb/hr x 8,760 hr/yr x ton/2,000 lb = 1.60x10 ⁻⁵ TPY See Attachment BC-EU1-F1.10.			
11. Potential, Fugitive, and Actual Emissions Comment: Emissions represent total for both boilers.			

EMISSIONS UNIT INFORMATION

POLLUTANT DETAIL INFORMATION

Section [1]
MWC Unit No. 1 and No. 2

Page [8] of [14]
Dioxin/Furan – D/F

**F2. EMISSIONS UNIT POLLUTANT DETAIL INFORMATION -
ALLOWABLE EMISSIONS**

Complete Subsection F2 if the pollutant identified in Subsection F1 is or would be subject to a numerical emissions limitation.

Allowable Emissions Allowable Emissions 1 of 2

1. Basis for Allowable Emissions Code: RULE	2. Future Effective Date of Allowable Emissions: Upon Approval of Application
3. Allowable Emissions and Units: 30 ng/dscm, corrected to 7 percent O₂	4. Equivalent Allowable Emissions: 8.02x10⁻⁶ lb/hour 3.19x10⁻⁵ tons/year
5. Method of Compliance: EPA Method 23 Annual Compliance Test	
6. Allowable Emissions Comment (Description of Operating Method): Based on 40 CFR 60, Subpart Cb Represents total of both boilers.	

Allowable Emissions Allowable Emissions 2 of 2

1. Basis for Allowable Emissions Code: RULE	2. Future Effective Date of Allowable Emissions:
3. Allowable Emissions and Units: 30 ng/dscm, corrected to 7 percent O₂	4. Equivalent Allowable Emissions: 7.14x10⁻⁶ lb/hour 7.60x10⁻⁵ tons/year
5. Method of Compliance: EPA Method 23 Annual Compliance Test	
6. Allowable Emissions Comment (Description of Operating Method): Based on 40 CFR 60, Subpart BBBB Represents total of both boilers.	

Allowable Emissions Allowable Emissions ____ of ____

1. Basis for Allowable Emissions Code:	2. Future Effective Date of Allowable Emissions:
3. Allowable Emissions and Units:	4. Equivalent Allowable Emissions: lb/hour tons/year
5. Method of Compliance:	
6. Allowable Emissions Comment (Description of Operating Method):	

EMISSIONS UNIT INFORMATION

POLLUTANT DETAIL INFORMATION

Section [1]
MWC Unit No. 1 and No. 2

Page [9] of [14]
Sulfur Dioxide – SO2

**F1. EMISSIONS UNIT POLLUTANT DETAIL INFORMATION –
POTENTIAL, FUGITIVE, AND ACTUAL EMISSIONS**

(Optional for unregulated emissions units.)

Complete a Subsection F1 for each pollutant identified in Subsection E if applying for an air construction permit or concurrent processing of an air construction permit and a revised or renewal Title V operation permit. Complete for each emissions-limited pollutant identified in Subsection E if applying for an air operation permit.

Potential, Estimated Fugitive, and Baseline & Projected Actual Emissions

1. Pollutant Emitted: Sulfur Dioxide – SO2		2. Total Percent Efficiency of Control:	
3. Potential Emissions: 71.08 lb/hour 82.16 tons/year		4. Synthetically Limited? <input type="checkbox"/> Yes <input checked="" type="checkbox"/> No	
5. Range of Estimated Fugitive Emissions (as applicable): to tons/year			
6. Emission Factor: 29 ppmvd at 7 percent O ₂ Reference: 40 CFR 60, Subpart Cb		7. Emissions Method Code: 0	
8.a. Baseline Actual Emissions (if required): 69.93 tons/year		8.b. Baseline 24-month Period: From: January 2002 To: December 2003	
9.a. Projected Actual Emissions (if required): 13.16 tons/year		9.b. Projected Monitoring Period: <input type="checkbox"/> 5 years <input checked="" type="checkbox"/> 10 years	
10. Calculation of Emissions: Per unit hourly: $100 \text{ ppmvd}/10^6 \times 2,116.8 \text{ lb}_f/\text{ft}^2 \times 60 \text{ min/hr} \times 35,669 \text{ dscf/min} \times 64 \text{ lb}_m\text{-}^\circ\text{R}/1,545.6 \text{ ft-lb}_f \times 1/(68+460)^\circ\text{R} = 35.54 \text{ lb/hr}$ Per unit hourly: $29 \text{ ppmvd}/10^6 \times 2,116.8 \text{ lb}_f/\text{ft}^2 \times 60 \text{ min/hr} \times 32,426 \text{ dscf/min} \times 64 \text{ lb}_m\text{-}^\circ\text{R}/1,545.6 \text{ ft-lb}_f \times 1/(68+460)^\circ\text{R} = 9.38 \text{ lb/hr}$ Per unit annually: $9.38 \text{ lb/hr} \times 8,760 \text{ hr/yr} \times \text{ton}/2,000 \text{ lb} = 41.08 \text{ TPY}$ See Attachment BC-EU1-F1.10.			
11. Potential, Fugitive, and Actual Emissions Comment: Emissions represent total for both boilers. The hourly potential emissions are based on historical CEMS data.			

EMISSIONS UNIT INFORMATION

POLLUTANT DETAIL INFORMATION

Section [1]
MWC Unit No. 1 and No. 2

Page [9] of [14]
Sulfur Dioxide – SO₂

**F2. EMISSIONS UNIT POLLUTANT DETAIL INFORMATION -
ALLOWABLE EMISSIONS**

Complete Subsection F2 if the pollutant identified in Subsection F1 is or would be subject to a numerical emissions limitation.

Allowable Emissions Allowable Emissions 1 of 2

1. Basis for Allowable Emissions Code: RULE	2. Future Effective Date of Allowable Emissions: Upon Approval of Application
3. Allowable Emissions and Units: 29 ppmvd, corrected to 7 percent O₂	4. Equivalent Allowable Emissions: 71.08 lb/hour 82.16 tons/year
5. Method of Compliance: Continuous Emissions Monitoring System (CEMs)	
6. Allowable Emissions Comment (Description of Operating Method): Based on 40 CFR 60, Subpart Cb Represents total of both boilers.	

Allowable Emissions Allowable Emissions 2 of 2

1. Basis for Allowable Emissions Code: RULE	2. Future Effective Date of Allowable Emissions:
3. Allowable Emissions and Units: 31 ppmvd, corrected to 7 percent O₂	4. Equivalent Allowable Emissions: 63.35 lb/hour 84.38 tons/year
5. Method of Compliance: Continuous Emissions Monitoring System (CEMs)	
6. Allowable Emissions Comment (Description of Operating Method): Based on 40 CFR 60, Subpart BBBB Represents total of both boilers.	

Allowable Emissions Allowable Emissions _____ of _____

1. Basis for Allowable Emissions Code:	2. Future Effective Date of Allowable Emissions:
3. Allowable Emissions and Units:	4. Equivalent Allowable Emissions: lb/hour tons/year
5. Method of Compliance:	
6. Allowable Emissions Comment (Description of Operating Method):	

EMISSIONS UNIT INFORMATION

POLLUTANT DETAIL INFORMATION

Section [1]
MWC Unit No. 1 and No. 2

Page [10] of [14]
Hydrochloric Acid – H106

**F1. EMISSIONS UNIT POLLUTANT DETAIL INFORMATION –
POTENTIAL, FUGITIVE, AND ACTUAL EMISSIONS**

(Optional for unregulated emissions units.)

Complete a Subsection F1 for each pollutant identified in Subsection E if applying for an air construction permit or concurrent processing of an air construction permit and a revised or renewal Title V operation permit. Complete for each emissions-limited pollutant identified in Subsection E if applying for an air operation permit.

Potential, Estimated Fugitive, and Baseline & Projected Actual Emissions

1. Pollutant Emitted: Hydrochloric Acid – H106		2. Total Percent Efficiency of Control:	
3. Potential Emissions: 11.74 lb/hour 46.76 tons/year		4. Synthetically Limited? <input type="checkbox"/> Yes <input checked="" type="checkbox"/> No	
5. Range of Estimated Fugitive Emissions (as applicable): to tons/year			
6. Emission Factor: 29 ppmvd at 7 percent O₂ Reference: 40 CFR 60, Subpart Cb		7. Emissions Method Code: 0	
8.a. Baseline Actual Emissions (if required): 37.32 tons/year		8.b. Baseline 24-month Period: From: January 2002 To: December 2003	
9.a. Projected Actual Emissions (if required): 22.75 tons/year		9.b. Projected Monitoring Period: <input type="checkbox"/> 5 years <input checked="" type="checkbox"/> 10 years	
10. Calculation of Emissions: Per unit hourly: $29 \text{ ppmvd}/10^6 \times 2,116.8 \text{ lb}_r/\text{ft}^2 \times 60 \text{ min/hr} \times 35,669 \text{ dscf/min} \times 36.46 \text{ lb}_m\text{-}^\circ\text{R}/1,545.6 \text{ ft-lb}_r \times 1/(68+460)^\circ\text{R} = 5.87 \text{ lb/hr}$ Per unit hourly: $29 \text{ ppmvd}/10^6 \times 2,116.8 \text{ lb}_r/\text{ft}^2 \times 60 \text{ min/hr} \times 32,426 \text{ dscf/min} \times 36.46 \text{ lb}_m\text{-}^\circ\text{R}/1,545.6 \text{ ft-lb}_r \times 1/(68+460)^\circ\text{R} = 5.34 \text{ lb/hr}$ Per unit annually: $5.34 \text{ lb/hr} \times 8,760 \text{ hr/yr} \times \text{ton}/2,000 \text{ lb} = 23.38 \text{ TPY}$ See Attachment BC-EU1-F1.10.			
11. Potential, Fugitive, and Actual Emissions Comment: Emissions represent total for both boilers.			

EMISSIONS UNIT INFORMATION

Section [1]
MWC Unit No. 1 and No. 2

POLLUTANT DETAIL INFORMATION

Page [10] of [14]
Hydrochloric Acid – H106

**F2. EMISSIONS UNIT POLLUTANT DETAIL INFORMATION -
ALLOWABLE EMISSIONS**

Complete Subsection F2 if the pollutant identified in Subsection F1 is or would be subject to a numerical emissions limitation.

Allowable Emissions Allowable Emissions 1 of 2

1. Basis for Allowable Emissions Code: RULE	2. Future Effective Date of Allowable Emissions: Upon Approval of Application
3. Allowable Emissions and Units: 29 ppmvd, corrected to 7 percent O₂	4. Equivalent Allowable Emissions: 11.74 lb/hour 46.76 tons/year
5. Method of Compliance: EPA Method 26 or 26A Annual Emission Test	
6. Allowable Emissions Comment (Description of Operating Method): Based on 40 CFR 60, Subpart Cb Represents total of both boilers.	

Allowable Emissions Allowable Emissions 2 of 2

1. Basis for Allowable Emissions Code: RULE	2. Future Effective Date of Allowable Emissions:
3. Allowable Emissions and Units: 31 ppmvd, corrected to 7 percent O₂	4. Equivalent Allowable Emissions: 11.19 lb/hour 48.03 tons/year
5. Method of Compliance: EPA Method 26 or 26A Annual Emission Test	
6. Allowable Emissions Comment (Description of Operating Method): Based on 40 CFR 60, Subpart BBBB Represents total of both boilers.	

Allowable Emissions Allowable Emissions of

1. Basis for Allowable Emissions Code:	2. Future Effective Date of Allowable Emissions:
3. Allowable Emissions and Units:	4. Equivalent Allowable Emissions: lb/hour tons/year
5. Method of Compliance:	
6. Allowable Emissions Comment (Description of Operating Method):	

EMISSIONS UNIT INFORMATION

POLLUTANT DETAIL INFORMATION

Section [1]
MWC Unit No. 1 and No. 2

Page [11] of [14]
Mercury - H114

**F1. EMISSIONS UNIT POLLUTANT DETAIL INFORMATION -
POTENTIAL, FUGITIVE, AND ACTUAL EMISSIONS**

(Optional for unregulated emissions units.)

Complete a Subsection F1 for each pollutant identified in Subsection E if applying for an air construction permit or concurrent processing of an air construction permit and a revised or renewal Title V operation permit. Complete for each emissions-limited pollutant identified in Subsection E if applying for an air operation permit.

Potential, Estimated Fugitive, and Baseline & Projected Actual Emissions

1. Pollutant Emitted: Mercury - H114.		2. Total Percent Efficiency of Control:	
3. Potential Emissions: 0.013 lb/hour 0.053 tons/year		4. Synthetically Limited? <input type="checkbox"/> Yes <input checked="" type="checkbox"/> No	
5. Range of Estimated Fugitive Emissions (as applicable): to tons/year			
6. Emission Factor: 50 µg/dscm at 7 percent O₂ Reference: 40 CFR 60, Subpart Cb		7. Emissions Method Code: 0	
8.a. Baseline Actual Emissions (if required): 0.044 tons/year		8.b. Baseline 24-month Period: From: January 2002 To: December 2003	
9.a. Projected Actual Emissions (if required): 0.0105 tons/year		9.b. Projected Monitoring Period: <input type="checkbox"/> 5 years <input checked="" type="checkbox"/> 10 years	
10. Calculation of Emissions: Per unit hourly: $50 \mu\text{g/dscm} \times \text{m}^3/35.32 \text{ cf} \times 35,669 \text{ dscf/min} \times \text{g}/10^6 \mu\text{g} \times \text{lb}/453.6 \text{ g} \times 60 \text{ min/hr} = 0.00668 \text{ lb/hr}$ Per unit 24-hourly: $50 \mu\text{g/dscm} \times \text{m}^3/35.32 \text{ cf} \times 32,426 \text{ dscf/min} \times \text{g}/10^6 \mu\text{g} \times \text{lb}/453.6 \text{ g} \times 60 \text{ min/hr} = 0.00607 \text{ lb/hr}$ Per unit annually: $0.00607 \text{ lb/hr} \times 8,760 \text{ hr/yr} \times \text{ton}/2,000 \text{ lb} = 0.0266 \text{ TPY}$ See Attachment BC-EU1-F1.10.			
11. Potential, Fugitive, and Actual Emissions Comment: Emissions represent total for both boilers.			

EMISSIONS UNIT INFORMATION

POLLUTANT DETAIL INFORMATION

Section [1]
MWC Unit No. 1 and No. 2

Page [11] of [14]
Mercury - H114

**F2. EMISSIONS UNIT POLLUTANT DETAIL INFORMATION -
ALLOWABLE EMISSIONS**

Complete Subsection F2 if the pollutant identified in Subsection F1 is or would be subject to a numerical emissions limitation.

Allowable Emissions Allowable Emissions 1 of 3

1. Basis for Allowable Emissions Code: RULE	2. Future Effective Date of Allowable Emissions: Upon Approval of Application
3. Allowable Emissions and Units: 50 µg/dscm, corrected to 7 percent O₂	4. Equivalent Allowable Emissions: 0.013 lb/hour 0.053 tons/year
5. Method of Compliance: EPA Method 29 Annual Compliance Test.	
6. Allowable Emissions Comment (Description of Operating Method): Based on 40 CFR 60, Subpart Cb Represents total of both boilers.	

Allowable Emissions Allowable Emissions 2 of 3

1. Basis for Allowable Emissions Code: RULE	2. Future Effective Date of Allowable Emissions:
3. Allowable Emissions and Units: 80 µg/dscm, corrected to 7 percent O₂	4. Equivalent Allowable Emissions: 0.019 lb/hour 0.082 tons/year
5. Method of Compliance: EPA Method 29 Annual Compliance Test.	
6. Allowable Emissions Comment (Description of Operating Method): Based on 40 CFR 60, Subpart BBB Represents total of both boilers.	

Allowable Emissions Allowable Emissions 3 of 3

1. Basis for Allowable Emissions Code: RULE	2. Future Effective Date of Allowable Emissions:
3. Allowable Emissions and Units: 70 µg/dscm, corrected to 7 percent O₂	4. Equivalent Allowable Emissions: 0.017 lb/hour 0.072 tons/year
5. Method of Compliance: EPA Method 29 Annual Compliance Test.	
6. Allowable Emissions Comment (Description of Operating Method): Based on Rule 62-296.416(3)(a)1. Represents total of both boilers.	

EMISSIONS UNIT INFORMATION

POLLUTANT DETAIL INFORMATION

Section [1]
MWC Unit No. 1 and No. 2

Page [12] of [14]
Fluorides - FL

**F1. EMISSIONS UNIT POLLUTANT DETAIL INFORMATION -
POTENTIAL, FUGITIVE, AND ACTUAL EMISSIONS**

(Optional for unregulated emissions units.)

Complete a Subsection F1 for each pollutant identified in Subsection E if applying for an air construction permit or concurrent processing of an air construction permit and a revised or renewal Title V operation permit. Complete for each emissions-limited pollutant identified in Subsection E if applying for an air operation permit.

Potential, Estimated Fugitive, and Baseline & Projected Actual Emissions

1. Pollutant Emitted: Fluorides - FL		2. Total Percent Efficiency of Control:	
3. Potential Emissions: 0.30 lb/hour 1.31 tons/year		4. Synthetically Limited? <input type="checkbox"/> Yes <input checked="" type="checkbox"/> No	
5. Range of Estimated Fugitive Emissions (as applicable): to tons/year			
6. Emission Factor: 0.15 lb/hr each boiler Reference: Permit Nos. PSD-FL-129 and 0050031-010-AV		7. Emissions Method Code: 0	
8.a. Baseline Actual Emissions (if required): 0.098 tons/year		8.b. Baseline 24-month Period: From: January 2005 To: December 2006	
9.a. Projected Actual Emissions (if required): 0.111 tons/year		9.b. Projected Monitoring Period: <input type="checkbox"/> 5 years <input checked="" type="checkbox"/> 10 years	
10. Calculation of Emissions: Per unit annually: 0.15 lb/hr x 8,760 hr/yr x ton/2,000 lb = 0.66 TPY See Attachment BC-EU1-F1.10.			
11. Potential, Fugitive, and Actual Emissions Comment: Emissions represent total for both boilers.			

EMISSIONS UNIT INFORMATION

POLLUTANT DETAIL INFORMATION

Section [1]
MWC Unit No. 1 and No. 2

Page [12] of [14]
Fluorides - FL

**F2. EMISSIONS UNIT POLLUTANT DETAIL INFORMATION -
ALLOWABLE EMISSIONS**

Complete Subsection F2 if the pollutant identified in Subsection F1 is or would be subject to a numerical emissions limitation.

Allowable Emissions Allowable Emissions 1 of 1

1. Basis for Allowable Emissions Code: OTHER	2. Future Effective Date of Allowable Emissions:
3. Allowable Emissions and Units: 0.15 lb/hr each boiler	4. Equivalent Allowable Emissions: 0.30 lb/hour 1.31 tons/year
5. Method of Compliance: EPA Method 13 or 13B Annual Compliance Test	
6. Allowable Emissions Comment (Description of Operating Method): Based on Permit Nos. PSD-FL-129 and 0050031-010-AV Represents total of both boilers.	

Allowable Emissions Allowable Emissions ____ of ____

1. Basis for Allowable Emissions Code:	2. Future Effective Date of Allowable Emissions:
3. Allowable Emissions and Units:	4. Equivalent Allowable Emissions: lb/hour tons/year
5. Method of Compliance:	
6. Allowable Emissions Comment (Description of Operating Method):	

Allowable Emissions Allowable Emissions ____ of ____

1. Basis for Allowable Emissions Code:	2. Future Effective Date of Allowable Emissions:
3. Allowable Emissions and Units:	4. Equivalent Allowable Emissions: lb/hour tons/year
5. Method of Compliance:	
6. Allowable Emissions Comment (Description of Operating Method):	

EMISSIONS UNIT INFORMATION

POLLUTANT DETAIL INFORMATION

Section [1]
MWC Unit No. 1 and No. 2

Page [13] of [14]
Sulfuric Acid Mist – SAM

**F1. EMISSIONS UNIT POLLUTANT DETAIL INFORMATION –
POTENTIAL, FUGITIVE, AND ACTUAL EMISSIONS**

(Optional for unregulated emissions units.)

Complete a Subsection F1 for each pollutant identified in Subsection E if applying for an air construction permit or concurrent processing of an air construction permit and a revised or renewal Title V operation permit. Complete for each emissions-limited pollutant identified in Subsection E if applying for an air operation permit.

Potential, Estimated Fugitive, and Baseline & Projected Actual Emissions

1. Pollutant Emitted: Sulfuric Acid Mist – SAM		2. Total Percent Efficiency of Control:	
3. Potential Emissions: 3.0 lb/hour 13.14 tons/year		4. Synthetically Limited? <input type="checkbox"/> Yes <input checked="" type="checkbox"/> No	
5. Range of Estimated Fugitive Emissions (as applicable): to tons/year			
6. Emission Factor: 1.5 lb/hr each boiler Reference: Permit Nos. PSD-FL-129 and 0050031-010-AV		7. Emissions Method Code: 0	
8.a. Baseline Actual Emissions (if required): 3.11 tons/year		8.b. Baseline 24-month Period: From: January 2002 To: December 2003	
9.a. Projected Actual Emissions (if required): 0.585 tons/year		9.b. Projected Monitoring Period: <input type="checkbox"/> 5 years <input checked="" type="checkbox"/> 10 years	
10. Calculation of Emissions: Per unit annually: 1.5 lb/hr x 8,760 hr/yr x ton/2,000 lb = 6.57 TPY See Attachment BC-EU1-F1.10.			
11. Potential, Fugitive, and Actual Emissions Comment: Emissions represent total for both boilers.			

EMISSIONS UNIT INFORMATION

POLLUTANT DETAIL INFORMATION

Section [1]
MWC Unit No. 1 and No. 2

Page [13] of [14]
Sulfuric Acid Mist – SAM

**F2. EMISSIONS UNIT POLLUTANT DETAIL INFORMATION -
ALLOWABLE EMISSIONS**

Complete Subsection F2 if the pollutant identified in Subsection F1 is or would be subject to a numerical emissions limitation.

Allowable Emissions Allowable Emissions 1 of 1

1. Basis for Allowable Emissions Code: OTHER	2. Future Effective Date of Allowable Emissions:
3. Allowable Emissions and Units: 1.5 lb/hr each boiler	4. Equivalent Allowable Emissions: 3.0 lb/hour 13.14 tons/year
5. Method of Compliance: EPA Method 8 or 8C Annual Compliance Test	
6. Allowable Emissions Comment (Description of Operating Method): Based on Permit Nos. PSD-FL-129 and 0050031-010-AV Represents total of both boilers.	

Allowable Emissions Allowable Emissions _____ of _____

1. Basis for Allowable Emissions Code:	2. Future Effective Date of Allowable Emissions:
3. Allowable Emissions and Units:	4. Equivalent Allowable Emissions: lb/hour tons/year
5. Method of Compliance:	
6. Allowable Emissions Comment (Description of Operating Method):	

Allowable Emissions Allowable Emissions _____ of _____

1. Basis for Allowable Emissions Code:	2. Future Effective Date of Allowable Emissions:
3. Allowable Emissions and Units:	4. Equivalent Allowable Emissions: lb/hour tons/year
5. Method of Compliance:	
6. Allowable Emissions Comment (Description of Operating Method):	

EMISSIONS UNIT INFORMATION

POLLUTANT DETAIL INFORMATION

Section [1]
MWC Unit No. 1 and No. 2

Page [14] of [14]
Volatile Organic Compounds – VOC

**F1. EMISSIONS UNIT POLLUTANT DETAIL INFORMATION –
POTENTIAL, FUGITIVE, AND ACTUAL EMISSIONS**

(Optional for unregulated emissions units.)

Complete a Subsection F1 for each pollutant identified in Subsection E if applying for an air construction permit or concurrent processing of an air construction permit and a revised or renewal Title V operation permit. Complete for each emissions-limited pollutant identified in Subsection E if applying for an air operation permit.

Potential, Estimated Fugitive, and Baseline & Projected Actual Emissions

1. Pollutant Emitted: Volatile Organic Compounds – VOC		2. Total Percent Efficiency of Control:	
3. Potential Emissions: 14.20 lb/hour 62.20 tons/year		4. Synthetically Limited? <input type="checkbox"/> Yes <input checked="" type="checkbox"/> No	
5. Range of Estimated Fugitive Emissions (as applicable): to tons/year			
6. Emission Factor: 7.10 lb/hr per boiler Reference: Permit Nos. PSD-FL-129 and 0050031-010-AV		7. Emissions Method Code: 0	
8.a. Baseline Actual Emissions (if required): 10.14 tons/year		8.b. Baseline 24-month Period: From: January 2002 To: December 2003	
9.a. Projected Actual Emissions (if required): 7.87 tons/year		9.b. Projected Monitoring Period: <input type="checkbox"/> 5 years <input checked="" type="checkbox"/> 10 years	
10. Calculation of Emissions: Per unit annually: 7.1 lb/hr x 8,760 hr/yr x 2,000 lb = 31.10 TPY See Attachment BC-EU1-F1.10.			
11. Potential, Fugitive, and Actual Emissions Comment: Emissions represent total for both boilers.			

EMISSIONS UNIT INFORMATION

POLLUTANT DETAIL INFORMATION

Section [1]
MWC Unit No. 1 and No. 2

Page [14] of [14]
Volatile Organic Compounds - VOC

**F2. EMISSIONS UNIT POLLUTANT DETAIL INFORMATION -
ALLOWABLE EMISSIONS**

Complete Subsection F2 if the pollutant identified in Subsection F1 is or would be subject to a numerical emissions limitation.

Allowable Emissions Allowable Emissions 1 of 1

1. Basis for Allowable Emissions Code: OTHER	2. Future Effective Date of Allowable Emissions:
3. Allowable Emissions and Units: 7.1 lb/hr per unit	4. Equivalent Allowable Emissions: 14.2 lb/hour 62.2 tons/year
5. Method of Compliance: Method 25 or 25A Annual Compliance Test	
6. Allowable Emissions Comment (Description of Operating Method): Based on Permit Nos. PSD-FL-129 and 0050031-010-AV Represents total of both boilers.	

Allowable Emissions Allowable Emissions _____ of _____

1. Basis for Allowable Emissions Code:	2. Future Effective Date of Allowable Emissions:
3. Allowable Emissions and Units:	4. Equivalent Allowable Emissions: lb/hour tons/year
5. Method of Compliance:	
6. Allowable Emissions Comment (Description of Operating Method):	

Allowable Emissions Allowable Emissions _____ of _____

1. Basis for Allowable Emissions Code:	2. Future Effective Date of Allowable Emissions:
3. Allowable Emissions and Units:	4. Equivalent Allowable Emissions: lb/hour tons/year
5. Method of Compliance:	
6. Allowable Emissions Comment (Description of Operating Method):	

EMISSIONS UNIT INFORMATION

Section [1]

MWC Unit No. 1 and No. 2

G. VISIBLE EMISSIONS INFORMATION

Complete Subsection G if this emissions unit is or would be subject to a unit-specific visible emissions limitation.

Visible Emissions Limitation: Visible Emissions Limitation 1 of 2

1. Visible Emissions Subtype: VE10	2. Basis for Allowable Opacity: <input checked="" type="checkbox"/> Rule <input type="checkbox"/> Other
3. Allowable Opacity: Normal Conditions: 10 % Exceptional Conditions: % Maximum Period of Excess Opacity Allowed: 6 min/hour	
4. Method of Compliance: EPA Method 9, Continuous Opacity Monitoring	
5. Visible Emissions Comment: 40 CFR 60, Subpart Cb	

Visible Emissions Limitation: Visible Emissions Limitation 2 of 2

1. Visible Emissions Subtype: VE10	2. Basis for Allowable Opacity: <input checked="" type="checkbox"/> Rule <input type="checkbox"/> Other
3. Allowable Opacity: Normal Conditions: 10 % Exceptional Conditions: % Maximum Period of Excess Opacity Allowed: 6 min/hour	
4. Method of Compliance: EPA Method 9, Continuous Opacity Monitoring	
5. Visible Emissions Comment: 40 CFR 60, Subpart BBBB	

EMISSIONS UNIT INFORMATION

Section [1]

MWC Unit No. 1 and No. 2

H. CONTINUOUS MONITOR INFORMATION

Complete Subsection H if this emissions unit is or would be subject to continuous monitoring.

Continuous Monitoring System: Continuous Monitor 1 of 3

1. Parameter Code: EM	2. Pollutant(s): NOx, CO, SO2
3. CMS Requirement:	<input checked="" type="checkbox"/> Rule <input type="checkbox"/> Other
4. Monitor Information... Manufacturer: Environnement S A Model Number: MIR 9000 Serial Number: See comment	
5. Installation Date: See comment	6. Performance Specification Test Date: December 2008
7. Continuous Monitor Comment: 40 CFR 60.38b Unit 1: Installation Date: May 17, 2005 Serial Number: 1490 Unit 2: Installation Date: June 6, 2005 Serial Number: 1488	

Continuous Monitoring System: Continuous Monitor 2 of 3

1. Parameter Code: O2	2. Pollutant(s): O2
3. CMS Requirement:	<input type="checkbox"/> Rule <input checked="" type="checkbox"/> Other
4. Monitor Information... Manufacturer: SERVOMEX Model Number: Series 2000 Serial Number: See comment	
5. Installation Date: See comment	6. Performance Specification Test Date: December 2008
7. Continuous Monitor Comment: 40 CFR 60.38b Unit 1: Installation Date: May 17, 2005 Serial Number: 1490 Unit 2: Installation Date: June 6, 2005 Serial Number: 1488	

EMISSIONS UNIT INFORMATION

**Section [1]
MWC Unit No. 1 and No. 2**

H. CONTINUOUS MONITOR INFORMATION (CONTINUED)

Continuous Monitoring System: Continuous Monitor 3 of 3

1. Parameter Code: VE	2. Pollutant(s):
3. CMS Requirement:	<input checked="" type="checkbox"/> Rule <input type="checkbox"/> Other
4. Monitor Information... Manufacturer: DURAG Model Number: DR 290-150 R111 Serial Number: See comment	
5. Installation Date: See comment	6. Performance Specification Test Date: December 2008
7. Continuous Monitor Comment: 40 CFR 60.38b Unit 1: Installation Date: May 17, 2005 Serial Number: 413275 Unit 2: Installation Date: June 6, 2005 Serial Number: 416131	

Continuous Monitoring System: Continuous Monitor ____ of ____

1. Parameter Code:	2. Pollutant(s):
3. CMS Requirement:	<input type="checkbox"/> Rule <input type="checkbox"/> Other
4. Monitor Information... Manufacturer: Model Number: Serial Number:	
5. Installation Date:	6. Performance Specification Test Date:
7. Continuous Monitor Comment:	

EMISSIONS UNIT INFORMATION

Section [1]

MWC Unit No. 1 and No. 2

I. EMISSIONS UNIT ADDITIONAL INFORMATION

Additional Requirements for All Applications, Except as Otherwise Stated

<p>1. Process Flow Diagram: (Required for all permit applications, except Title V air operation permit revision applications if this information was submitted to the department within the previous five years and would not be altered as a result of the revision being sought)</p> <p><input checked="" type="checkbox"/> Attached, Document ID: <u>BC-EU1-11</u> <input type="checkbox"/> Previously Submitted, Date _____</p>
<p>2. Fuel Analysis or Specification: (Required for all permit applications, except Title V air operation permit revision applications if this information was submitted to the department within the previous five years and would not be altered as a result of the revision being sought)</p> <p><input checked="" type="checkbox"/> Attached, Document ID: <u>BC-EU1-12</u> <input type="checkbox"/> Previously Submitted, Date _____</p>
<p>3. Detailed Description of Control Equipment: (Required for all permit applications, except Title V air operation permit revision applications if this information was submitted to the department within the previous five years and would not be altered as a result of the revision being sought)</p> <p><input checked="" type="checkbox"/> Attached, Document ID: <u>BC-EU1-13</u> <input type="checkbox"/> Previously Submitted, Date _____</p>
<p>4. Procedures for Startup and Shutdown: (Required for all operation permit applications, except Title V air operation permit revision applications if this information was submitted to the department within the previous five years and would not be altered as a result of the revision being sought)</p> <p><input checked="" type="checkbox"/> Attached, Document ID: <u>BC-EU1-14</u> <input type="checkbox"/> Previously Submitted, Date _____</p> <p><input type="checkbox"/> Not Applicable (construction application)</p>
<p>5. Operation and Maintenance Plan: (Required for all permit applications, except Title V air operation permit revision applications if this information was submitted to the department within the previous five years and would not be altered as a result of the revision being sought)</p> <p><input type="checkbox"/> Attached, Document ID: _____ <input type="checkbox"/> Previously Submitted, Date _____</p> <p><input checked="" type="checkbox"/> Not Applicable</p>
<p>6. Compliance Demonstration Reports/Records:</p> <p><input type="checkbox"/> Attached, Document ID: _____</p> <p>Test Date(s)/Pollutant(s) Tested: _____</p> <p><input checked="" type="checkbox"/> Previously Submitted, Date: <u>January 2009</u></p> <p>Test Date(s)/Pollutant(s) Tested: <u>PM, HCl, Pb, Hg, Cd, FL, SAM, D/F</u></p> <p><input checked="" type="checkbox"/> To be Submitted, Date (if known): <u>February 2010</u></p> <p>Test Date(s)/Pollutant(s) Tested: <u>PM, HCl, Pb, Hg, Cd, FL, SAM, D/F</u></p> <p><input type="checkbox"/> Not Applicable</p> <p>Note: For FESOP applications, all required compliance demonstration records/reports must be submitted at the time of application. For Title V air operation permit applications, all required compliance demonstration reports/records must be submitted at the time of application, or a compliance plan must be submitted at the time of application.</p>
<p>7. Other Information Required by Rule or Statute:</p> <p><input checked="" type="checkbox"/> Attached, Document ID: <u>Attachment A</u> <input type="checkbox"/> Not Applicable</p>

EMISSIONS UNIT INFORMATION

Section [1]

MWC Unit No. 1 and No. 2

I. EMISSIONS UNIT ADDITIONAL INFORMATION (CONTINUED)**Additional Requirements for Air Construction Permit Applications**

1. Control Technology Review and Analysis (Rules 62-212.400(10) and 62-212.500(7), F.A.C.; 40 CFR 63.43(d) and (e)): <input type="checkbox"/> Attached, Document ID: _____ <input checked="" type="checkbox"/> Not Applicable
2. Good Engineering Practice Stack Height Analysis (Rules 62-212.400(4)(d) and 62-212.500(4)(f), F.A.C.): <input type="checkbox"/> Attached, Document ID: _____ <input checked="" type="checkbox"/> Not Applicable
3. Description of Stack Sampling Facilities: (Required for proposed new stack sampling facilities only) <input type="checkbox"/> Attached, Document ID: _____ <input checked="" type="checkbox"/> Not Applicable

Additional Requirements for Title V Air Operation Permit Applications

1. Identification of Applicable Requirements: <input type="checkbox"/> Attached, Document ID: _____
2. Compliance Assurance Monitoring: <input type="checkbox"/> Attached, Document ID: _____ <input checked="" type="checkbox"/> Not Applicable
3. Alternative Methods of Operation: <input type="checkbox"/> Attached, Document ID: _____ <input checked="" type="checkbox"/> Not Applicable
4. Alternative Modes of Operation (Emissions Trading): <input type="checkbox"/> Attached, Document ID: _____ <input checked="" type="checkbox"/> Not Applicable

Additional Requirements Comment

--

ATTACHMENT BC-EU1-F1.10
EMISSIONS CALCULATIONS

**BC-EU1-F1.10a
MAXIMUM POLLUTANT EMISSION RATES BASED ON SUBPART Cb
BAY COUNTY RESOURCE MANAGEMENT CENTER**

Regulated Pollutant	Basis of Emission Factor	Emission Factor (at 7% O ₂)	References	Maximum Emission Rate per Unit			Total Annual Emission Rate For Both Units TPY
				Maximum 4-hr ^a lb/hr	Maximum 24-hr ^b lb/hr	Annual (TPY) ^c	
Particulate Matter (TSP/PM ₁₀)	40 CFR 60, Subpart Cb	25 mg/dscm	1	3.34	3.04	13.30	26.60
Sulfur Dioxide	CEMS Data	100 ppmvd, 4-hr	2	35.54	—	—	—
	40 CFR 60, Subpart Cb	29 ppmvd ^d	1	—	9.38	41.08	82.16
Hydrogen Chloride	40 CFR 60, Subpart Cb	29 ppmvd ^e	1	5.87	5.34	23.38	46.76
Nitrogen Oxides	CEMS Data	400 ppmvd, 4-hr	2	102.18	—	—	—
	40 CFR 60, Subpart Cb	210 ppmvd	1	—	48.78	213.7	427.30
Carbon Monoxide	CEMS Data	1,000 ppmvd, 4-hr	2	155.49	—	—	—
	40 CFR 60, Subpart Cb	250 ppmvd, 24-hr	1	—	35.34	154.8	309.57
Volatile Organic Compounds	Title V Permit	7 lb/hr	3	7.1	7.1	31.1	62.20
Lead	40 CFR 60, Subpart Cb	400 ug/dscm	1	0.053	0.0486	0.21	0.43
Mercury	40 CFR 60, Subpart Cb	50 ug/dscm ^f	1	0.00668	0.00607	0.0266	0.053
Cadmium	40 CFR 60, Subpart Cb	35 ug/dscm	1	0.00468	0.00425	0.0186	0.0372
Fluorides	Title V Permit	0.15 lb/hr	3	0.15	0.15	0.657	1.31
Sulfuric Acid Mist	Title V Permit	1.5 lb/hr	3	1.5	1.5	6.570	13.14
Dioxin/Furan	40 CFR 60, Subpart Cb	30 ng/dscm	1	4.01E-06	3.64E-06	1.60E-05	3.19E-05

Notes:

lb/hr = pounds per hour.
 mg/dscm = milligrams per dry standard cubic meter.
 ug/m³ = micrograms per actual cubic meter.
 ng/dscm = nanograms per dry standard cubic meter

PM₁₀ = particulate matter with an aerodynamic diameter less than 10 microns.
 ppmvd = parts per million by volume dry.
 TPY = tons per year.
 TSP = total suspended particulate.

References:

1. Emission limit with April 28, 2009, compliance date, per 40 CFR 60, Subpart Cb.
2. Based on historical CEMS data.
3. Emission limit per permit PSD-FL-129.

Footnotes:

- ^a Based on a steam rate of 74,800 lb/hr, with a corresponding flue gas flow rate of 35,669 dscfm at 7% oxygen (10-percent above 24-hr rates).
^b Based on a steam rate of 68,000 lb/hr and 255 TPD MSW, with a corresponding flue gas flow rate of 32,426 dscfm at 7% oxygen.
^c Based on 24-hour limit and 365 days/yr operation.
^d CFR 40 60.33b(b)(3)(i) allows an SO₂ concentration in the flue gas discharged to the atmosphere of 29 ppmvd @ 7% O₂ or a 75% reduction in weight or volume (whichever is less stringent).
^e CFR 40 60.33b(b)(3)(ii) allows an HCl concentration in the flue gas discharged to the atmosphere of 31 ppmvd @ 7% O₂ or a 95% reduction in weight or volume (whichever is less stringent).
^f CFR 40 60.33b(a)(3) allows a mercury concentration in the flue gas discharged to the atmosphere of 50 ug/dscm @ 7% O₂ or an 85% reduction by weight (whichever is less stringent).

Calculations:

To calculate emissions with an emission factor (EF) in terms of gr/dscf: $lb/hr = EF(gr/dscf) \times flow\ rate(dscfm) \times 60\ (min/hr)/7000$
 To calculate emissions with an emission factor (EF) in terms of mg/dscm: $lb/hr = (EF(mg/dscm) \times flow\ rate\ (dscm/min) \times 2.832E-2(m^3/ft^3) \times 2.205E-3\ (lb/g) \times 60(min/hr))/1E3$
 To calculate emissions with an emission factor (EF) in terms of ug/dscm: $lb/hr = (EF(ug/dscm) \times flow\ rate\ (dscm/min) \times 2.832E-2(m^3/ft^3) \times 2.205E-3\ (lb/g) \times 60(min/hr))/1E6$
 To calculate emissions with an emission factor (EF) in terms of ppmvd: $lb/hr = (EF(ppmvd) \times MW \times flow\ rate(dscf/min) \times 2,116.8\ lb/ft^2 \times 60(min/hr))/(1,545\ ft^3/lb_m \cdot R \times 528^{\circ}R \times 1E6)$

Checked By: DB
 Reviewed By: DB

**BC-EU1-F1.10b
MAXIMUM POLLUTANT EMISSION RATES BASED ON SUBPART BBBB
BAY COUNTY RESOURCE MANAGEMENT CENTER**

Regulated Pollutant	Basis of Emission Factor	Emission Factor (at 7% O ₂)	References	Maximum Emission Rate per Unit			Total Annual Emission Rate For Both Units TPY
				Maximum 4-hr ^a lb/hr	Maximum 24-hr ^b lb/hr	(TPY) ^c	
Particulate Matter (TSP/PM ₁₀)	40 CFR 60, Subpart BBBB	27 mg/dscm	1	3.22	3.15	13.8	27.60
Sulfur Dioxide	CEMS Data	100 ppmvd, 4-hr	2	31.68	—	—	—
	40 CFR 60, Subpart BBBB	31 ppmvd	1	—	9.63	42.2	84.38
Hydrogen Chloride	40 CFR 60, Subpart BBBB	31 ppmvd	1	5.59	5.48	24.0	48.03
Nitrogen Oxides	CEMS Data	400 ppmvd, 4-hr	2	91.07	—	—	—
	40 CFR 60, Subpart BBBB	170 ppmvd, 24-hr	1	—	37.94	166.2	332.35
Carbon Monoxide	CEMS Data	1,000 ppmvd, 4-hr	2	138.59	—	—	—
	40 CFR 60, Subpart BBBB	250 ppmvd, 24-hr	1	—	33.95	148.7	297.43
Volatile Organic Compounds	Title V Permit	7 lb/hr	3	7.1	7.1	31.1	62.20
Lead	40 CFR 60, Subpart BBBB	0.490 mg/dscm	1	0.058	0.057	0.25	0.501
Mercury	40 CFR 60, Subpart BBBB	0.080 mg/dscm	1	0.00953	0.00934	0.041	0.082
	Rule 62-296.416(3)(a)1.	70 ug/dscm	4	0.00834	0.00817	0.036	0.072
Cadmium	40 CFR 60, Subpart BBBB	0.040 mg/dscm	1	0.00476	0.00467	0.020	0.0409
Fluorides	Title V Permit	0.15 lb/hr	3	0.15	0.15	0.657	1.31
Sulfuric Acid Mist	Title V Permit	1.5 lb/hr	3	1.5	1.5	6.570	13.14
Dioxin/Furan	40 CFR 60, Subpart BBBB	30 ng/dscm	1	3.57E-06	3.50E-06	3.80E-05	7.60E-05

Notes:

lb/hr = pounds per hour.

mg/dscm = milligrams per dry standard cubic meter.

ug/m³ = micrograms per actual cubic meter.

ng/dscm = nanograms per dry standard cubic meter

References:

1. Emission limit with per 40 CFR 60, Subpart BBBB.
2. Based on historical CEMS data.
3. Emission limit per permit PSD-FL-129.
4. State of Florida rule.

Footnotes:

^a Based on a steam rate of 66,667 lb/hr, with a corresponding flue gas flow rate of 31,790 dscfm at 7% oxygen.

^b Based on a steam rate of 65,333 lb/hr and 245 TPD MSW, with a corresponding flue gas flow rate of 31,154 dscfm at 7% oxygen.

^c Based on 24-hour limit and 365 days/yr operation.

PM₁₀ = particulate matter with an aerodynamic diameter less than 10 microns.

ppmvd = parts per million by volume dry.

TPY = tons per year.

TSP = total suspended particulate.

Calculations:

To calculate emissions with an emission factor (EF) in terms of gr/dscf: $lb/hr = EF(gr/dscf) \times flow\ rate(dscfm) \times 60\ (min/hr)/7000$

To calculate emissions with an emission factor (EF) in terms of mg/dscm: $lb/hr = (EF(mg/dscm) \times flow\ rate\ (dscm/min) \times 2.832E-2(m^3/ft^3) \times 2.205E-3\ (lb/g) \times 60(min/hr))/1E3$

To calculate emissions with an emission factor (EF) in terms of ug/dscm: $lb/hr = (EF(ug/dscm) \times flow\ rate\ (dscm/min) \times 2.832E-2(m^3/ft^3) \times 2.205E-3\ (lb/g) \times 60(min/hr))/1E6$

To calculate emissions with an emission factor (EF) in terms of ppmvd: $lb/hr = (EF(ppmvd) \times MW \times flow\ rate(dscf/min) \times 2,116.8\ lb/ft^2 \times 60(min/hr))/(1,545\ ft-lb/lb_m \cdot ^\circ R \times 528^\circ R \times 1E6)$

Checked By: DB
Reviewed By: DB

ATTACHMENT BC-EU1-11
PROCESS FLOW DIAGRAM

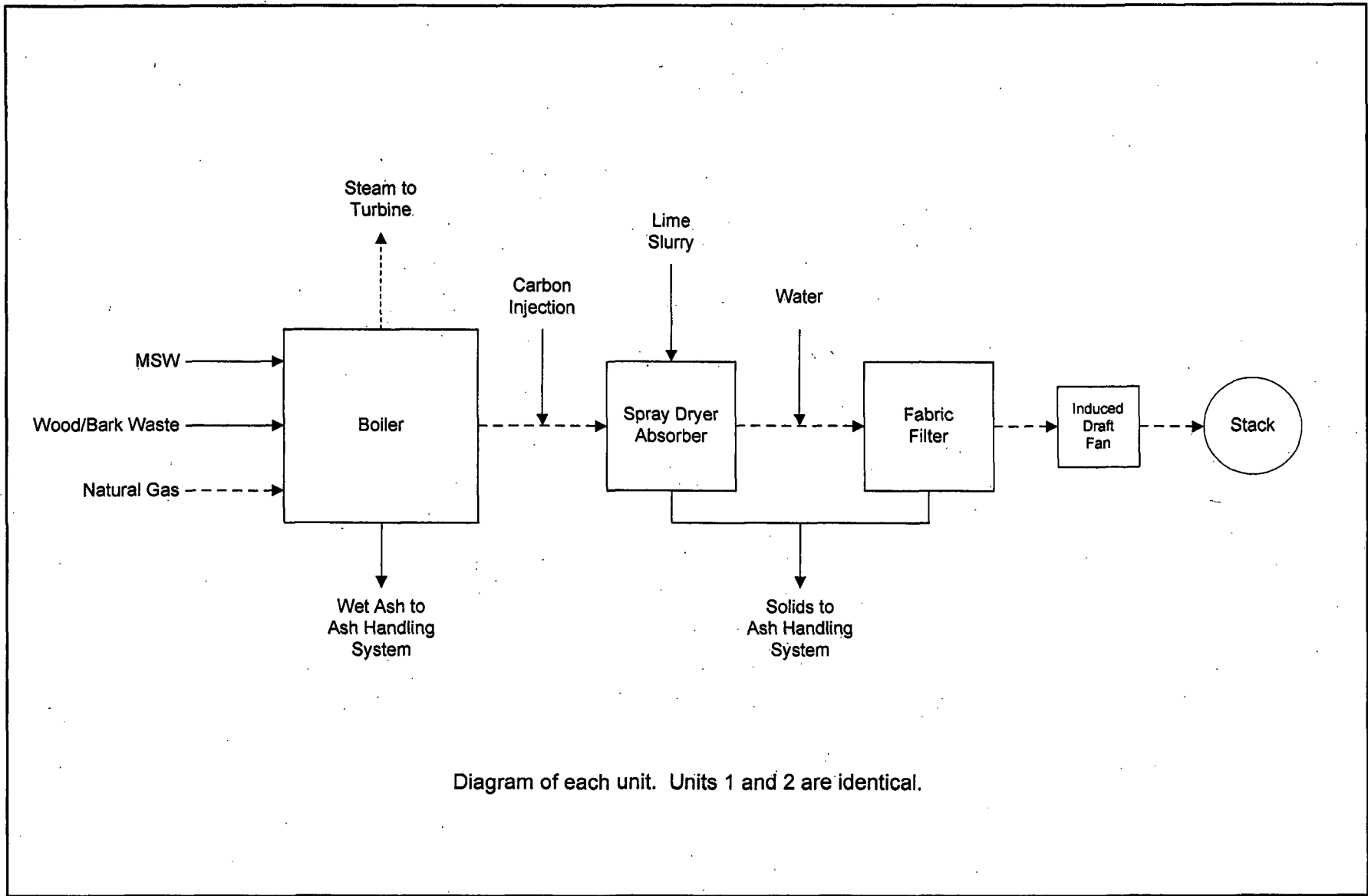

Diagram of each unit. Units 1 and 2 are identical.

Attachment BC-EU1-11
Boiler Process Flow Diagram
MWC Unit Nos. 1 and 2
Bay County Waste-to-Energy Facility

Process Flow Legend	
Solid/Liquid	—————>
Gas	- - - - ->
Steam	· · · · ·>



ATTACHMENT BC-EU1-I2
FUEL ANALYSIS OR SPECIFICATION

ATTACHMENT BC-EU1-I2
FUEL ANALYSIS

Fuel	Municipal Solid Waste^a (MSW)	Natural Gas
Density (lb/gal, lb/scf)		0.048
Moisture (%)	25.3	<0.01
Sulfur Weight (%)	0.2	<0.001
Nitrogen Weight (%)	0.5	0.62
Ash Weight (%)	25.3	--
Heat Capacity	4,500 Btu/lb	1,000 Btu/scf

Source:

^a Bay County Waste-to-Energy Facility, Operating Manual – Refuse Delivery System

ATTACHMENT BC-EU1-13

DETAILED DESCRIPTION OF CONTROL EQUIPMENT

PROCEDURES/DESCRIPTION

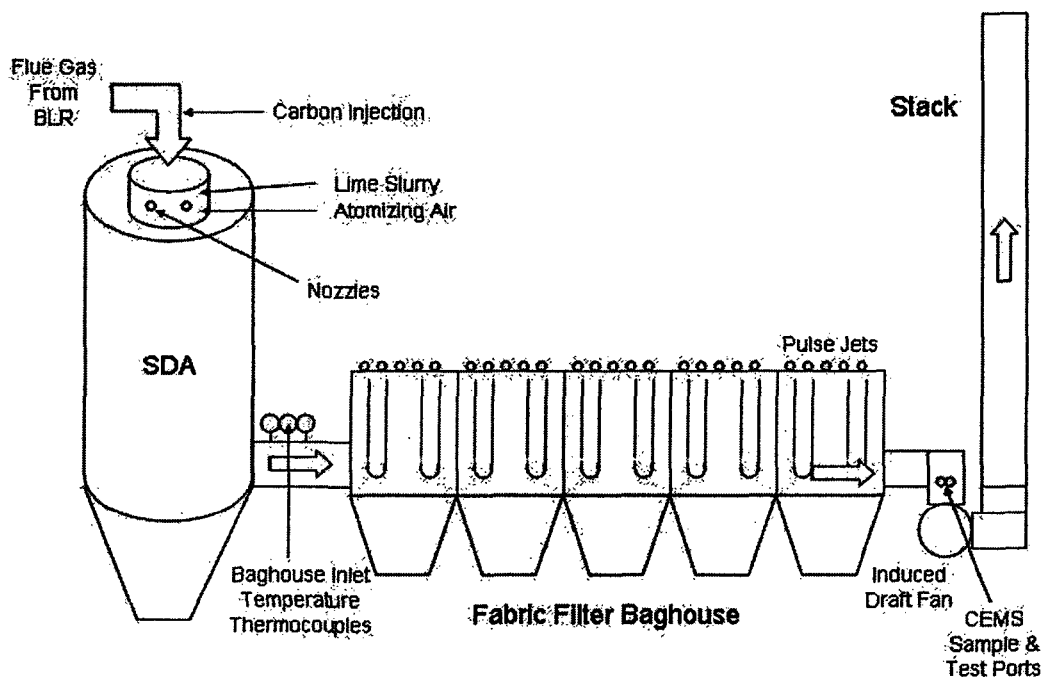

Air Pollution Control Equipment

The Air Pollution Control System consists of two (2) identical trains, one for each operating boiler. Each train consists of a SDA, three baghouse inlet thermocouples, a five cell baghouse, an Induced Draft (ID) Fan, CEMS, and stack. One APC is identified as Unit #1 and the other is Unit #2. Both trains are supplied by several common systems which include the Lime, Scrubber Water, and Carbon Feed Systems. Electrical power is supplied to the APC equipment from the APC MCC building which houses MCC-1B and 2B, the baghouse and Macawber system control panels, ID Fan frequency drives, and the communication hub for the Ovation Control System. The CEMs Multi-gas Analyzers for each unit are housed in the CEMS Building located between the two stacks.

Flue gas from the discharge of the air heater flows to the top of the SDA where it branches into five (5) chambers which contain the spray nozzles. The spray nozzles inject atomized lime slurry into the flue gas to neutralize the SO₂ and HCL. The SO₂ is neutralized when the calcium in the lime slurry combines with sulfuric acid and oxygen to form Calcium Sulfate (CaSO₃) and the HCL is neutralized when the calcium and chlorine in the SDA react to form Calcium Chloride.

The flue gas exits the SDA and enters the baghouse inlet duct. There are three temperature thermocouples located in the baghouse inlet duct for monitoring baghouse inlet temperature. To meet the requirements of the Title V Air Permit, this temperature must not exceed 17°C (62.6°F) above the demonstrated temperature during the annual compliance (stack) test for dioxin. The flue gas then passes through the five baghouse cells before being pulled through the ID Fan and discharged out the stack. Fabric filter bags in the baghouse remove flyash (which contains metals) from the gas stream before it leaves the facility through the stack. A pulse jet system is installed on all the baghouse cells to clean the bags based on the baghouse differential pressure (DP) setpoint. When pulsed, the ash falls from the bags into the hopper

located at the bottom of each cell. The Macawber system then conveys the ash as described in the Section 13 (Ash Handling Section) of this manual.

Sample connections at the inlet of the ID Fan pull Opacity, O₂, CO, SO₂, and NO_x samples from the flue gas and send them to the CEMS Analyzers for continuous monitoring. This provides an instantaneous display of readings on both the CEMS and the Ovation. Sample ports are also provided at the inlet of the SDA and ID Fan for conducting annual compliance testing.

The APC System is comprised of four subsystems: Lime/slurry, Spray Dryer Absorber (SDA), Fabric Filter (Baghouse), and carbon injection. These systems perform the following functions:

Lime: The lime system prepares lime slurry for use in the SO₂ and HCL neutralization process in a sufficient quantity and concentration to maintain continuous flue gas treatment in the SDA. The system has been designed for batch mixing to provide this service.

Spray Dryer Absorber (SDA): Untreated flue gas and reagent lime slurry combine in the SDA, resulting in the neutralization and removal of the acid components contained in the gas stream. The two streams, lime slurry and boiler exhaust gas, combine, and result in a dry product and scrubbed gas exiting the absorber chamber.

Fabric Filter Baghouse: The baghouse is used to remove entrained particulate matter (flyash, acid gas reaction products, calcium salts, etc.) from the flue gas prior to exhausting to the atmosphere. The particulate matter is filtered from the flue gas as it passes through the fiberglass filter bags. In addition, some un-reacted lime accumulates on the filter bags where the lime provides additional acid gas removal.

Carbon Injection: Carbon is injected in the flue gas stream at the inlet of the SDA for the removal of Mercury. The system utilizes a loss of weight feeder to inject dry carbon into the inlet duct of the SDA.

Lime System

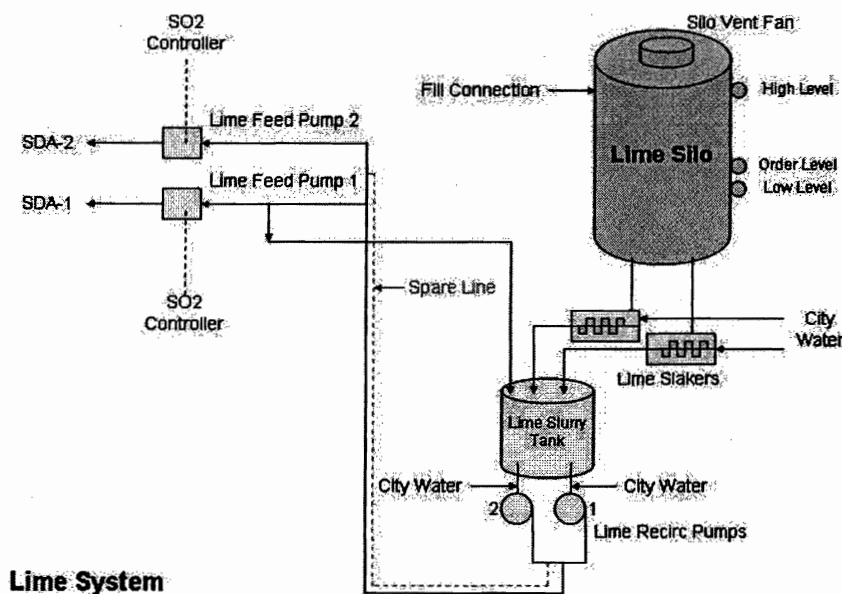

The lime system prepares lime slurry for use in the spray dryer absorber to neutralize any acid gases in the exhaust flue gases from the combustor/boilers. The lime system consists of the lime silo, slakers, lime slurry tank, lime recirc pumps, and the lime slurry feed pumps.

Pebble-size lime (CaO-Calcium Oxide) is delivered to the plant via self-contained pneumatic truck trailers. The lime is unloaded from the truck trailer to the lime silo, above the lime preparation area. The silo is sized to hold enough lime to maintain several days of system operation of each flue gas cleaning train at the maximum combustion rate of the boilers. Normal operation requires that about 60 tons/week of lime be unloaded to the storage silos to maintain APC System operation. The silo can hold 70 tons of lime. The maximum design operation requires about 104 tons/week of lime. The silo is equipped with level probes that alert the operator when there is a high level, a low level, or lime needs to be ordered.

The lime silo has two conical discharges. Lime is discharged through a silo conical discharge to a slaking train. Two slaking trains are supplied. Normally, only one slaking train, and therefore, one silo discharge, is operational to supply the APC System. However, both slaking trains may be operated simultaneously during periods of high slurry demand. Knife-gates are installed in the chute beneath the lime silo (feed bin) to select whichever slaking train is operational. The flow of the material from each silo discharge is aided by a pneumatic bin impactor. Variable speed rotary feeders are used to meter lime to the slakers in the proportions required for slaking.

The pebble-sized lime flows by gravity from the rotary feeders to paste-type slakers where it is slaked to a slurry of hydrated lime and water. The slakers mix and slake the lime, using abrasion resistant counter rotating intermeshing paddles, and provide a vessel for the slaking reaction to occur. Approximately 2.8 lbs of water are required to slake each pound of pebble lime. Eight to fifteen gallons per minute of slaked lime slurry, with a solids content of approximately 12%, flows by gravity from the paste slakers to the slurry grit screens.

Water is sprayed onto the surface of the grit screens at a rate of approximately 3 GPM to remove grit and large particles of lime that will not pass the #20-mesh screens. Wet grit is discharged from each screen for disposal. Lime slurry passing the grit screen flows by gravity to the lime slurry tank. The water sprayed onto the grit screen is mixed with the lime slurry as it passes through the screen before entering the lime slurry storage tank. The rate that water is added to the lime slurry may be varied so that a desired 12% lime solids concentration can be achieved in the slurry tank. An agitator, in the slurry tank, incorporates and mixes the slaked lime slurry and added water to maintain the suspension of lime solids.

The lime slakers can be operated automatically or manually from the slaker control panel. In manual mode, the operator must control the water and lime from the local panel. In automatic mode, the slaker starts up when slurry tank level drops to 50% and continues to slake lime until the tank level reaches 80%. This is the preferred method of operation.

The lime recirculation pump takes a suction from the lime slurry tank and pumps it at about 35 GPM through a recirculation loop to the lime feed pump in the SDA. The lime recirc pumps are Flowserve Mark 3, LO-Flo, 40 GPM, 1700 rpm pumps. The lime feed pump is a Flowserve, variable speed, reciprocating pump that varies its output based on the SO₂ controller. If the units SO₂ is higher than the setpoint (normally 20 ppm), the controller speeds the pump up and more slurry flows to the nozzles. When the SO₂ drops below the setpoint, the pump slows down and lime slurry flow is decreased.

SDA (Spray Dryer Absorber)

The function of the SDA is to provide a reaction vessel in which the lime slurry can be injected with the hot flue gases to neutralize any acid gases produced during the combustion process. The SDA system begins at the flue gas inlet to the absorber vessel and ends at the SDA outlet duct (inlet to the fabric filter).

Slurry flow to each SDA mixing chamber is metered by a flow control valve to obtain the proper feed concentration to the SDA atomizer. Automatic adjustment to the flow is made as a function of the output from the SO₂ analyzer monitoring the gas discharge from the fabric filter. The quantity of slurry metered to the mixing tee is proportional to the concentration of SO₂ measured.

Baghouse Inlet Temperature Control Water (TCV-133 & 233) from the Scrubber Water tank is provided by the Scrubber Water Pumps located in #2 SDA. Scrubber water flow through the control valve is increased or decreased based on the temperature of the flue gas exiting the SDA (Baghouse Inlet Temperature). Atomizing Air is supplied to the nozzles through Flow Control Valves (FCV-102 & 202).

The slurry passes through the atomizer nozzle which discharges the slurry through the nozzles at high velocity. The design of the atomizer and the discharge velocity of the slurry creates a cloud of finely divided droplets around the periphery of the atomizer.

Flue gas enters from the top of the SDA through a cyclonic roof gas disperser. The disperser directs the flue gas into the zones filled by the atomized slurry cloud where violent mixing of the flue gas and slurry and most of the chemical absorption occurs.

Atomizing Nozzles

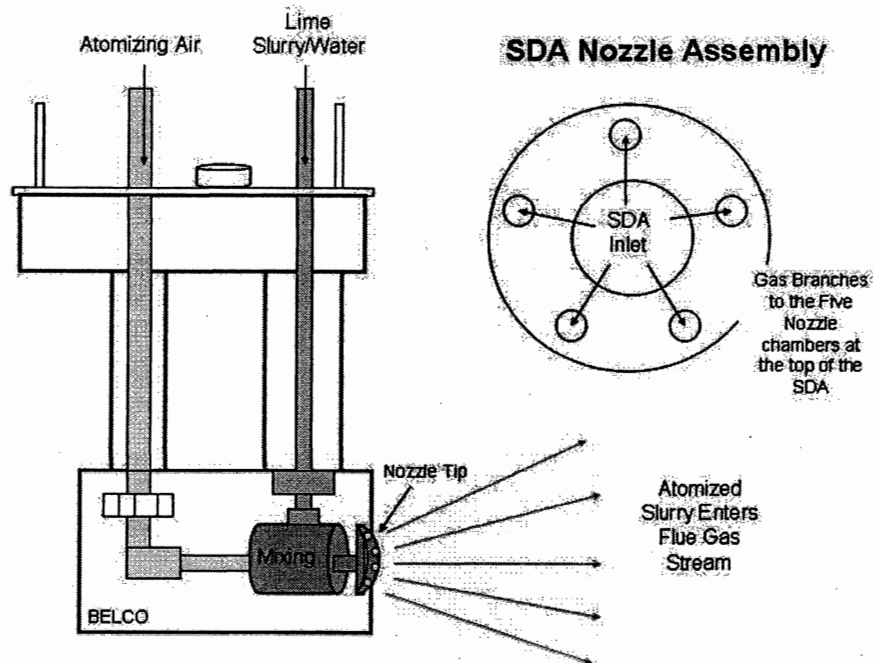

Each SDA is equipped with five BELCO nozzles. Each nozzle is supplied by two hoses. One hose delivers air and the other delivers the lime slurry/scrubber water mixture. Atomizing air and the lime slurry/scrubber water mixture from the mixing chamber enters the nozzle, increases velocity, and sprays a fine mist into the gas stream.

Fabric Filter Baghouse

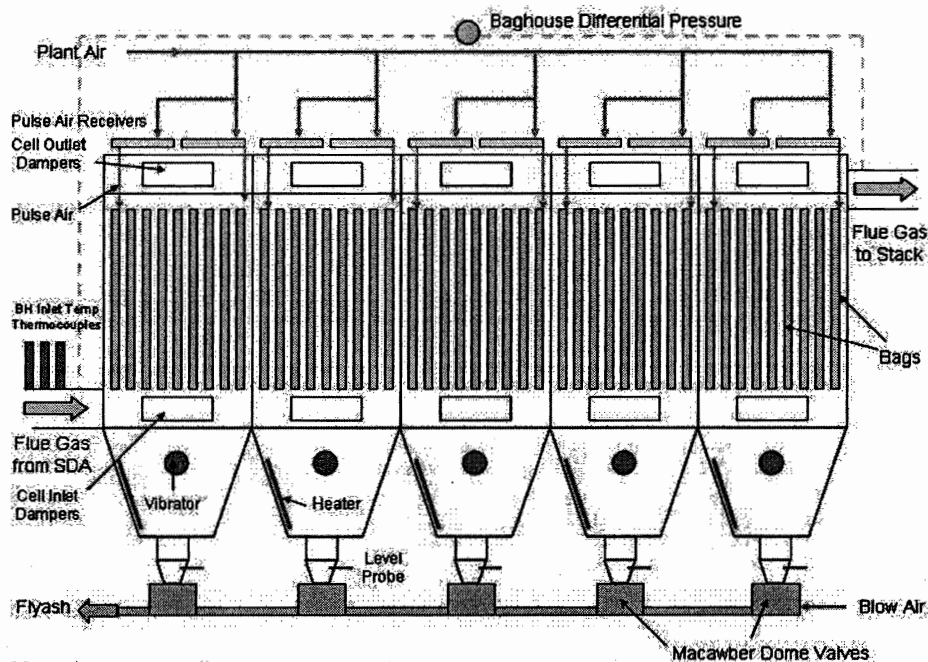

Baghouse Components

The fabric filter (baghouse) is used to remove entrained particulate matter (fly ash, acid gas reaction products, calcium salts, etc.) from the flue gas prior to exhausting to the atmosphere. The particulate matter is filtered from the flue gas as it passes through the fiberglass filter bags. In addition, some un-reacted lime accumulates on the filter bags which provides additional acid gas removal.

Gas exhausted from the SDA enters the baghouse at the inlet ducting to the cells. The baghouse unit is comprised of five individual cells. Each cell is equipped with an inlet and outlet damper. Within each filter cell the gas is passed through filter bags. The gas passes from the outside to the inside of the filter bags. Particulate, entrained within the flue gas stream, is deposited on the outside surface of the filter bags as the flue gas passes through the bag. The cleaned flue gas then passes into a common duct and is exhausted to the stack.

Particulate matter is continuously deposited on the outside surface of the filter bags. This will eventually result in an increase in pressure loss (drop) across each cell. To protect the fabric bags from "blinding", which results from increased accumulations of particulate matter (dust) on the bags and a high differential pressure, the bags are periodically cleaned. Blinding is the loss of air moving through the bags. The particles are imbedded in the bag and cannot be removed by the usual bag cleaning (blasts of pulse jet air).

The Baghouses utilizes a pulse jet type system for cleaning the bags. Pulses of compressed air (at a pressure of 65-85 psig) are directed into the bags clean side to flex and clean the filter bags. Each cell is equipped with air receivers and solenoid valves for supplying the air to the

blow pipes. The pulse air is distributed to the bags through a pipe with holes positioned above each bag. Each row of bags has a pipe installed above the bags in the row. There are 240 bags in each cell (15 x 16). The pulse sequence is either started at the end of a timed cycle or when the differential pressure (PDT-133 & PDT-233) across the baghouse reaches a predetermined setpoint, normally 6.0"wc (DPSET-133 & DPSET- 233).

When a cleaning cycle is initiated, the solenoid valve, one row at a time, energizes open and pulses the bags in that row with a pulse of air. The air blows down the center of the bag causing the bag to ripple. This ripple knocks the deposited particulate matter off the bag and deposits it in the ash hopper. From this point, the Macawber conveying system takes over. At a regularly timed interval (normally 3-5 minutes or when the baghouse pulse system is activated), the Macawber system cycles to convey the ash from the baghouse hopper to the reception hopper in the building. This process is described in section 13 (Ash Handling) of this manual.

The inlet and outlet of each of the five cells is connected to a common inlet and outlet duct. Dampers are installed at each cell inlet and out to allow each cell to be isolated from gas flow for bag cleaning or maintenance. These dampers are controlled from the baghouse control cabinet in the new MCC. On the front of each unit cabinet is a display of the system overview. The display utilizes touch screen technology for opening or closing a damper, taking a cell off line, and adjusting the baghouse DP setpoint.

Three temperature thermocouples are located in the inlet duct to each baghouse. These thermocouples are used by the baghouse inlet temperature flow control valves (FCV-133 & 233) to control baghouse inlet temperature. This temperature limit is established during annually stack testing for dioxin/furans. Baghouse inlet temperature must not exceed the average demonstrated temperature during the stack test runs by more than 17°C. (TE-106A, B, & C and TE-206A, B, & C). Baghouse inlet temperature is the average of the three thermocouples.

The scrubber water system provides the water used to control the baghouse inlet temperature.

Scrubber Water System

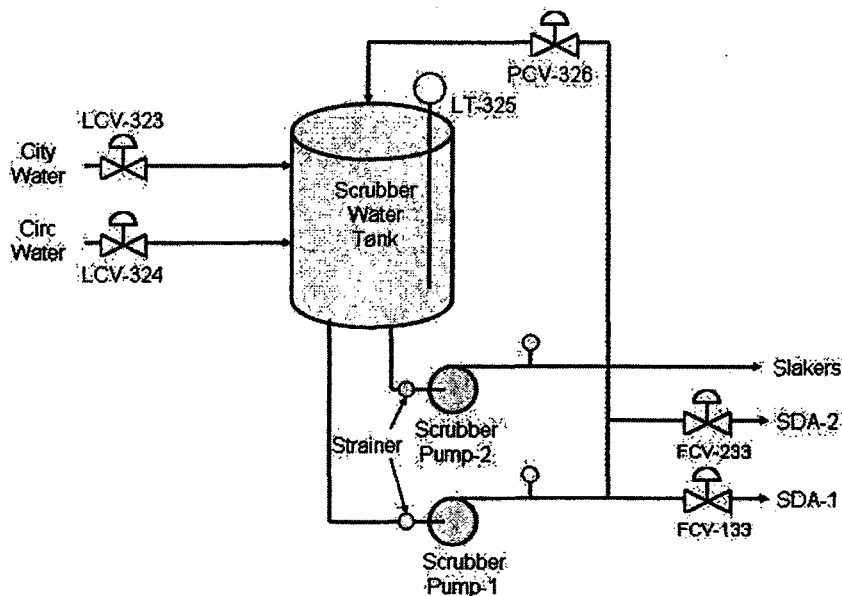

Scrubber Water System

The primary purpose of the scrubber water system is to supply cooling water for controlling the baghouse inlet temperatures. The system consists of a tank, two pumps (centrifugal type), makeup water control valves, and the necessary piping for supplying the slakers and baghouse inlet temperature control valves in the SDA's. Scrubber water mixes with the lime slurry in the mixer located at the supply line to the nozzles in each SDA.

The scrubber water pumps take suction from the scrubber tank and pump water to the inlet of both baghouse temperature control valves (FCV-133 & 233). The pumps are Goulds, Model 3196, centrifugal, 175 GPM, and 460 v type. The valves are controlled automatically by the Ovation control system based on the temperature setpoint (normally 350°F) at the baghouse inlet. When temperature is greater than the setpoint (350°F), the valve opens to provide cooling water. When the temperature drops below 350°F, the valve closes.

The scrubber water system is also designed to provide water to the slakers. Water is normally supplied from the city water system but the necessary piping and valves are installed for using scrubber water if needed. The isolation valves are located locally in the slaker building at the inlet to the slakers.

A tank is installed to store scrubber water and ensure suction to the pumps. The tank is equipped with a level transmitter (LT-325) which provides tank level indication and a signal to the control system. Tank level is normally controlled automatically by the Ovation control system. The tank can either be filled from the city water system (LCV-323) or the cooling tower (CT) blowdown (LCV-324). A booster pump is installed at the circ water (CT) blowdown that can be operated to provide makeup to the scrubber water tank. The tank is normally operated with a level setpoint of 75%. When tank level drops below 75%, the designated level control valve opens and fills the tank. When level rises to 75%, the level control valve shuts.

Carbon Injection System

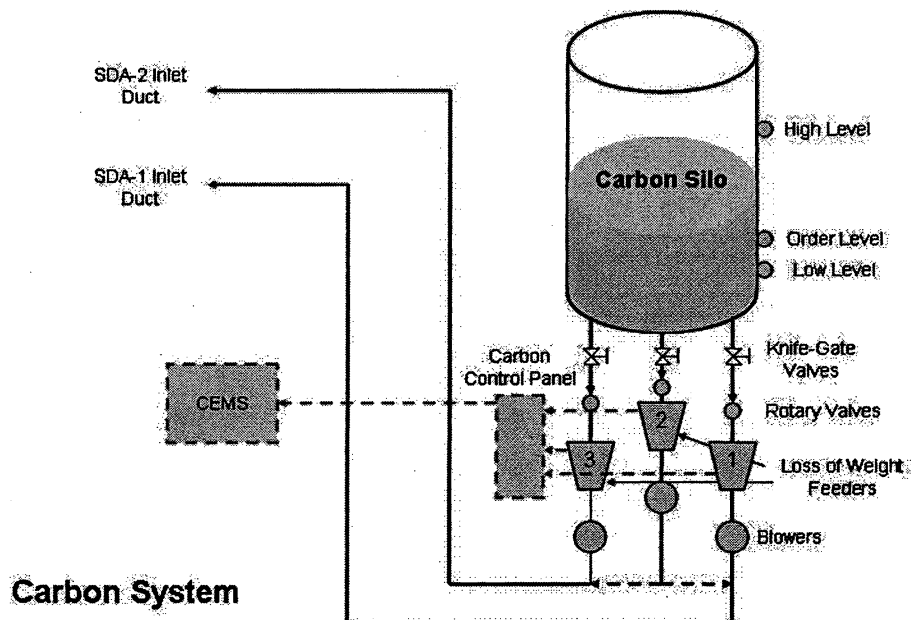

The carbon injection system is used to inject dry-activated carbon into the flue gas at the inlet of each SDA for Mercury removal. The required feed rate for carbon is determined during the annual stack test for Mercury. The feed rate is determined by averaging three stack test runs.

The carbon injection system consists of a carbon silo, three carbon feeders, three blowers, the carbon injection control panel, and the necessary piping for delivering the carbon to the inlet duct of each SDA. Three separate feeder legs are installed in the system. #1 Carbon Feeder is normally lined up to supply SDA-1 and #3 Carbon Feeder is normally lined up to supply SDA-2. #2 Carbon Feeder is an installed spare that has the necessary piping and connections to supply either SDA.

The carbon silo holds approximately 60,000 pounds of activated carbon. This correlates to about 1½ truckloads of carbon, which leaves sufficient room for handling a truck load when the level reaches the order level. A Merrick Model 73-264 vent filter is installed at the top of the silo that operates during filling operations. The filter captures dust and provides pressure equalization during pneumatic silo filling operations. At the bottom of the silo are three legs, one for each carbon feeder. A knife-gate valve is installed in each leg to allow a feeder to be isolated for maintenance.

Carbon travels through the knife-gate valve to the rotary valve. A rotary valve is installed in each leg of the silo to regulate the flow of carbon to the feeder and maintain a good airlock condition. The rotary valve feeds carbon to the carbon feeder to maintain a level in the feeder.

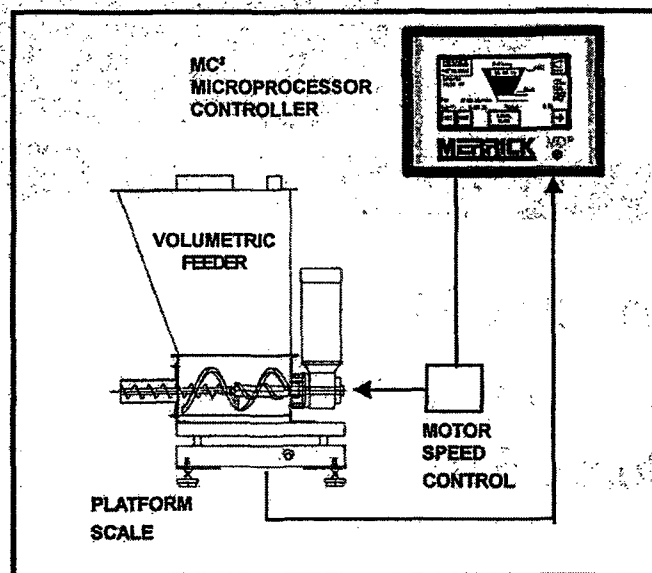

The carbon feeder consists of a Merrick Model 100 volumetric screw feeder and series 510 scale. The screw feeder volumetrically delivers dry activated carbon to the inlet of the blower. The auger draws carbon out of the integral storage hopper and its speed can be varied to increase or decrease the carbon feed rate. The scale utilizes a single strain gauge load cell to sense applied load. When load is applied to the scale, an analog signal proportional to the applied load is transmitted from the load cell to the microprocessor controller. The microprocessor converts the loss in weight signal to a carbon feed rate in lbs/hr.

Based on the carbon feed rate setpoint, the feeder sends the required amount of carbon to the inlet of a Fox Venturi Eductor. A blower is installed on the eductor to provide motive air. The eductor converts the output of the blower into suction that is used to entrain and feed the carbon. It acts to compress the air/solids mixture to a pressure adequate to overcome losses in

the downstream conveying line to the SDA. The eductor has three connections, motive air, carbon inlet from the feeder, and the discharge to the conveying pipe.

The carbon injection system is operated from the carbon control panel. A display screen on the control panel utilizes touch screen technology for aligning and operating the carbon injection system. There are two modes of operation, AUTO and MANUAL. In AUTO, the system operates automatically to inject carbon based on the setpoint. In MANUAL, each component of the system can be started and stopped by selecting it on the touch screen. The system is normally operated in the AUTO mode. MANUAL mode is generally reserved for troubleshooting and maintenance.

System Maintenance

Follow all safety policies and procedures when performing preventive and corrective maintenance on the air pollution control system and components.

The following preventive maintenance activities are performed on the system:

Lime System

- Verify operation of the lime system during auxiliary operator rounds each shift.
- Clean and inspect the lime recirculation pump strainers daily.
- Operate the standby slaker weekly PM.
- Inspect and grease the paddle bearings weekly PM.
- Operate the standby lime recirculation weekly PM.
- Clean and inspect the SDA nozzles weekly PM.
- Change grit screens monthly PM
- Clean, inspect and replace as necessary, slaker cutoff spray nozzles monthly PM.
- Clean and inspect the lime silo vent filter semi-annual PM.
- Clean and inspect lime system piping semi-annually.
- Calibrate the lime slurry tank level transmitter annually.
- Calibrate the lime feed transmitter annually.

SDA

- Clean and inspect the SDA semi-annually.
- Inspect and replace SDA nozzle tips semi-annually.

Baghouse/Scrubber Water

- Replace baghouse inlet temperature thermocouples when failed.
- Operate the standby scrubber water pump weekly.
- Clean scrubber water pump suction strainer weekly.
- Inspect baghouse cranes prior to use.
- Cycle inlet and outlet dampers for each cell semi-annually.
- Inspect baghouse cells and condition of the bags annually.
- Inspect pulse air system for proper operation annually.
- Replace upper baghouse door gaskets annually.
- Calibrate the scrubber water tank level transmitter annually.

-
- Perform a visi-lite bag inspection if opacity increases, baghouse DP is high, or every three years.

Carbon Injection System

- Operate the standby carbon feeder weekly.
- Perform the quarterly carbon inventory and balance with carbon usage.
- Calibrate the carbon weight scale annually.
- Clean and inspect the carbon silo vent filter annually.

ATTACHMENT BC-EU1-I4
STARTUP AND SHUTDOWN PROCEDURES

Startup Procedure for: Combustor/Boiler

Step No.	Description
1	Clear all applicable safety tags and locks.
2	Complete the following procedures. A. SU-11A (Ovation / Control Room Pre-Startup Checklist) B. SU-11C (Boiler Pre-Startup Inspection) C. SU-118 (Boiler Valve Lineup Checklist)
3	Start ash system in accordance with procedure su-9 and have A.O. verify proper operation.
4	Adjust steam drum water level to 0.0 INWC for start up.
5	Start motor driven forced circ. Pump and have A.O. verify proper operation.
6	Have A.O. double dose chemicals in appropriate BFS tank and start BFS pump.
7	Start ram/combustor hydraulic system.
8	Start ID fan: A. Close ID fan damper man 0%. B. Set ID fan speed to man 0%. C. Start ID fan. D. Have A.O. verify proper operation.
9	In manual mode, set ID fan damper and speed to 40%. Note: This is done to prevent overloading of the ID fan motor when pumping cold air through the boiler.
10	Test ram/combustor hydraulic system and have A.O. verify proper operation of resistance door, rams, and combustor. Set combustor speed to 2 RPH.
11	Maintain steam drum water level during heat up between -2 and + 2.
12	Start FD fan: A. Close FD fan damper manual 0%. B. Set FD fan speed to manual 0%. C. Start FD fan and have A.O. verify proper operation.
13	Adjust ID fan damper and speed to maintain a draft of -.45.
14	Adjust FD fan damper, speed, and zone air to establish limits for burner.
15	Ensure burner is aligned and limits made.
16	Start furnace burner.
17	Adjust burner to establish a heat up rate not to exceed 100 degrees per hour.
18	Stop the FD fan and close dampers.
19	At 15 psi on steam drum, close drum vents.
20	Place attemperator in automatic and adjust set point to 750 deg.
21	At 400 deg. Combustor water outlet temp. Start boiler feed pump in accordance with procedure # su-5a.
22	Open seal water supply to combustor rotary joint.
23	Have FEL operator load feed conveyors until fuel is at the top of the incline.
24	When the flue gas temp at the exit of the precipitator reaches 350 deg., fill feedchute and start rams to introduce a sufficient amount of fuel into the combustor to start a fire. (Fill feedchute and empty twice) Leave feedchute empty at this time.
25	Stop rams and continue slowly rolling fuel down the combustor until it ignites. Ensure raw MSW is not rolled into the residue conveyor.
26	When a fire is established start FD fan in the same manner as step 12.
27	Place ID fan damper and speed in automatic.
28	Fill feedchute and place conveyors in automatic.

29	When a fire is established and emissions are in limits, stop burner.
30	Start rams in automatic at a rate to maintain combustion.
31	Set FD fan speed in auto with a set point of 80%. Set FD fan damper at man 100%.
32	Adjust zone dampers, rams, and combustor as necessary to bring unit on line.
33	At 20k steam flow, close Superheater vents.
34	Have A.O. line up Feedwater system and maintain water level.
35	At > 30k steam flow place steam drum level controller in auto at a set point of 0.0.
36	Place zone dampers in cascade.
37	Set steam flow controller at 65.5 k and place in automatic.
38	Place O ₂ controller in auto at a set point of 5%.
39	Place SDA and Baghouse Macawber Systems in operation.
40	Boiler is on line monitor and control as necessary.

Shutdown Procedure for: Boiler/Combustor

Step No.	Description
1	Notify the entire operating shift and management that the boiler is being taken off line.
2	Notify Gulf Power that the boiler is coming off line and why, request the new scheduled power production.
3	Stop feeding fuel to the conveyor system supplying the boiler that is coming off line.
4	When all the fuel on the conveyor has been fed into the feed chute, place the feed chute level controller in manual and stop the loading and incline conveyors.
5	When all the fuel has been fed into the combustor and the feed chute is empty stop the rams.
6	Put all the combustor air flow controllers in the automatic mode and decrease the air flows as the fuel burns out.
7	Stop the secondary air fan.
8	When the steam flow decrease to 20 KLB, open the super heater vents.
9	When all the fuel in the combustor is burned out: A. Put the steam flow controller in manual 0%. B. Put the FD fan speed in manual 0%. C. Put the FD fan damper in manual 0%. D. Stop the FD fan. Note: the cool down rate should not be greater than 100 degrees an hour.
10	Increase the combustor roll to 10 RPH until all the ash is out of the combustor then reduce the set point to 2 RPH and continue to rotate the combustor until the combustor water outlet temp. Cools to 250 degrees F.
11	Close the continuous blow down valve.
12	Put all the combustor air flow controllers in the manual mode, and close all zone dampers.
13	When the boiler pressure reaches 15 psig open the steam drum vents.
14	When the combustor water outlet temp. cools to 150 degrees, stop the combustor rotation.
15	Close the seal water supply to the rotary joint.
16	Open the resistance door and install the safety pin.
17	Stop the ram/combustor hydraulic pump system.
18	Stop the combustor forced circulation pumps.
19	Place the Feedwater regulator in manual 0%.
20	Close the inlet to attemperator fcv-151
21	Close the Feedwater stop valve (knocker valve).
22	Stop the wet sifting conveyor.
23	Stop the rapping sequence on the precipitator.
24	Manually blow the Macawber system until all hoppers are empty and blow line is clear by checking hopper draft and blow cycle gauge.
25	Place the Macawber in the off position.
26	Stop the screw conveyor and rotary valve.
27	Place the ID fan speed and damper in the manual mode at 40% to maintain a draft. Note: This is done to keep ventilation in the unit.

28	If necessary for maintenance/safety reasons: A: place the ID fan speed at manual 0%. B: stop ID fan. C: place ID fan damper at manual 50%.
29	Notify the shift manager that the boiler is down and cooled off.

EMISSIONS UNIT INFORMATION

Section [2]

Misc Unregulated Emissions

III. EMISSIONS UNIT INFORMATION

Title V Air Operation Permit Application - For Title V air operation permitting only, emissions units are classified as regulated, unregulated, or insignificant. If this is an application for an initial, revised or renewal Title V air operation permit, a separate Emissions Unit Information Section (including subsections A through I as required) must be completed for each regulated and unregulated emissions unit addressed in this application. Some of the subsections comprising the Emissions Unit Information Section of the form are optional for unregulated emissions units. Each such subsection is appropriately marked. Insignificant emissions units are required to be listed at Section II, Subsection C.

Air Construction Permit or FESOP Application - For air construction permitting or federally enforceable state air operation permitting, emissions units are classified as either subject to air permitting or exempt from air permitting. The concept of an "unregulated emissions unit" does not apply. If this is an application for an air construction permit or FESOP, a separate Emissions Unit Information Section (including subsections A through I as required) must be completed for each emissions unit subject to air permitting addressed in this application for air permit. Emissions units exempt from air permitting are required to be listed at Section II, Subsection C.

Air Construction Permit and Revised/Renewal Title V Air Operation Permit Application - Where this application is used to apply for both an air construction permit and a revised or renewal Title V air operation permit, each emissions unit is classified as either subject to air permitting or exempt from air permitting for air construction permitting purposes, and as regulated, unregulated, or insignificant for Title V air operation permitting purposes. A separate Emissions Unit Information Section (including subsections A through I as required) must be completed for each emissions unit addressed in this application that is subject to air construction permitting and for each such emissions unit that is a regulated or unregulated unit for purposes of Title V permitting. (An emissions unit may be exempt from air construction permitting but still be classified as an unregulated unit for Title V purposes.) Emissions units classified as insignificant for Title V purposes are required to be listed at Section II, Subsection C.

If submitting the application form in hard copy, the number of this Emissions Unit Information Section and the total number of Emissions Unit Information Sections submitted as part of this application must be indicated in the space provided at the top of each page.

EMISSIONS UNIT INFORMATION

Section [2]

Misc Unregulated Emissions

A. GENERAL EMISSIONS UNIT INFORMATION

Title V Air Operation Permit Emissions Unit Classification

1. Regulated or Unregulated Emissions Unit? (Check one, if applying for an initial, revised or renewal Title V air operation permit. Skip this item if applying for an air construction permit or FESOP only.)

The emissions unit addressed in this Emissions Unit Information Section is a regulated emissions unit.

The emissions unit addressed in this Emissions Unit Information Section is an unregulated emissions unit.

Emissions Unit Description and Status

1. Type of Emissions Unit Addressed in this Section: (Check one)

This Emissions Unit Information Section addresses, as a single emissions unit, a single process or production unit, or activity, which produces one or more air pollutants and which has at least one definable emission point (stack or vent).

This Emissions Unit Information Section addresses, as a single emissions unit, a group of process or production units and activities which has at least one definable emission point (stack or vent) but may also produce fugitive emissions.

This Emissions Unit Information Section addresses, as a single emissions unit, one or more process or production units and activities which produce fugitive emissions only.

2. Description of Emissions Unit Addressed in this Section:

Ash Handling System, MSW Processing System, Lime and Carbon Silos

3. Emissions Unit Identification Number:

4. Emissions Unit Status Code:

A

5. Commence Construction Date:

6. Initial Startup Date:

7. Emissions Unit Major Group SIC Code:

8. Federal Program Applicability: (Check all that apply)

Acid Rain Unit

CAIR Unit

Hg Budget Unit

9. Package Unit:

Manufacturer:

Model Number:

10. Generator Nameplate Rating: MW

11. Emissions Unit Comment:

EMISSIONS UNIT INFORMATION

Section [2]

Misc Unregulated Emissions

Emissions Unit Control Equipment/Method: Control 1 of 2

1. Control Equipment/Method Description:
Process Enclosed

2. Control Device or Method Code: **054**

Emissions Unit Control Equipment/Method: Control 2 of 2

1. Control Equipment/Method Description:
Baghouse (Low-temperature)

2. Control Device or Method Code: **018**

Emissions Unit Control Equipment/Method: Control ____ of ____

1. Control Equipment/Method Description:

2. Control Device or Method Code:

Emissions Unit Control Equipment/Method: Control ____ of ____

1. Control Equipment/Method Description:

2. Control Device or Method Code:

EMISSIONS UNIT INFORMATION

Section [2]

Misc Unregulated Emissions

B. EMISSIONS UNIT CAPACITY INFORMATION

(Optional for unregulated emissions units.)

Emissions Unit Operating Capacity and Schedule

1. Maximum Process or Throughput Rate: 510 TPD MSW at 4,500 Btu/lb		
2. Maximum Production Rate:		
3. Maximum Heat Input Rate:	million Btu/hr	
4. Maximum Incineration Rate:	pounds/hr tons/day	
5. Requested Maximum Operating Schedule:	24 hours/day	7 days/week
	52 weeks/year	8,760 hours/year
6. Operating Capacity/Schedule Comment:		

EMISSIONS UNIT INFORMATION

Section [2]

Misc Unregulated Emissions

C. EMISSION POINT (STACK/VENT) INFORMATION

(Optional for unregulated emissions units.)

Emission Point Description and Type

1. Identification of Point on Plot Plan or Flow Diagram:		2. Emission Point Type Code:	
3. Descriptions of Emission Points Comprising this Emissions Unit for VE Tracking:			
4. ID Numbers or Descriptions of Emission Units with this Emission Point in Common:			
5. Discharge Type Code:		6. Stack Height: feet	7. Exit Diameter: feet
8. Exit Temperature: °F		9. Actual Volumetric Flow Rate: acfm	10. Water Vapor: %
11. Maximum Dry Standard Flow Rate: dscfm		12. Nonstack Emission Point Height: feet	
13. Emission Point UTM Coordinates... Zone: East (km): North (km):		14. Emission Point Latitude/Longitude... Latitude (DD/MM/SS) Longitude (DD/MM/SS)	
15. Emission Point Comment:			

EMISSIONS UNIT INFORMATION

Section [2]

Misc Unregulated Emissions

D. SEGMENT (PROCESS/FUEL) INFORMATION**Segment Description and Rate: Segment 1 of 4**

1. Segment Description (Process/Fuel Type): External Combustion Boilers; Electrical Generation; Solid Waste; Municipal Solid Waste.		
2. Source Classification Code (SCC): 1-01-012-01		3. SCC Units: Tons Burned
4. Maximum Hourly Rate: 23.38	5. Maximum Annual Rate: 186,150	6. Estimated Annual Activity Factor:
7. Maximum % Sulfur: 0.16	8. Maximum % Ash: 28	9. Million Btu per SCC Unit: 9
10. Segment Comment: Represents MSW handled and stored at the facility. Maximum rates total both units. Maximum annual rate based on 510 TPD MSW 4,500 Btu/lb per unit.		

Segment Description and Rate: Segment 2 of 4

1. Segment Description (Process/Fuel Type): Mineral Products; Bulk Materials Conveyors; Other Not Classified		
2. Source Classification Code (SCC): 3-05-105-99		3. SCC Units: Tons Processed
4. Maximum Hourly Rate:	5. Maximum Annual Rate:	6. Estimated Annual Activity Factor:
7. Maximum % Sulfur:	8. Maximum % Ash:	9. Million Btu per SCC Unit:
10. Segment Comment: Represents Ash Handling System		

EMISSIONS UNIT INFORMATION

Section [2]

Misc Unregulated Emissions

D. SEGMENT (PROCESS/FUEL) INFORMATION (CONTINUED)**Segment Description and Rate: Segment 3 of 4**

1. Segment Description (Process/Fuel Type): Lime manufacture; Lime silos		
2. Source Classification Code (SCC): 3-05-016-13		3. SCC Units: Tons Lime Produced
4. Maximum Hourly Rate: 25	5. Maximum Annual Rate: 1,000	6. Estimated Annual Activity Factor:
7. Maximum % Sulfur:	8. Maximum % Ash:	9. Million Btu per SCC Unit:
10. Segment Comment: Refers to lime throughput for lime silo.		

Segment Description and Rate: Segment 4 of 4

1. Segment Description (Process/Fuel Type): Bulk materials Storage Bins; Chemical; Activated Carbon		
2. Source Classification Code (SCC): 3-05-102-96		3. SCC Units: Tons Processed
4. Maximum Hourly Rate: 25	5. Maximum Annual Rate: 55	6. Estimated Annual Activity Factor:
7. Maximum % Sulfur:	8. Maximum % Ash:	9. Million Btu per SCC Unit:
10. Segment Comment: Refers to carbon throughput for carbon silo.		

EMISSIONS UNIT INFORMATION

Section [2]

Misc Unregulated Emissions

E. EMISSIONS UNIT POLLUTANTS

List of Pollutants Emitted by Emissions Unit

1. Pollutant Emitted	2. Primary Control Device Code	3. Secondary Control Device Code	4. Pollutant Regulatory Code
PM	054	018	NS
PM10	054	018	NS
PM2.5	054	018	NS
VOC			NS

**F1. EMISSIONS UNIT POLLUTANT DETAIL INFORMATION –
POTENTIAL, FUGITIVE, AND ACTUAL EMISSIONS**

(Optional for unregulated emissions units.)

Complete a Subsection F1 for each pollutant identified in Subsection E if applying for an air construction permit or concurrent processing of an air construction permit and a revised or renewal Title V operation permit. Complete for each emissions-limited pollutant identified in Subsection E if applying for an air operation permit.

Potential, Estimated Fugitive, and Baseline & Projected Actual Emissions

1. Pollutant Emitted:		2. Total Percent Efficiency of Control:	
3. Potential Emissions: lb/hour tons/year		4. Synthetically Limited? <input type="checkbox"/> Yes <input type="checkbox"/> No	
5. Range of Estimated Fugitive Emissions (as applicable): to tons/year			
6. Emission Factor: Reference:		7. Emissions Method Code:	
8.a. Baseline Actual Emissions (if required): tons/year		8.b. Baseline 24-month Period: From: To:	
9.a. Projected Actual Emissions (if required): tons/year		9.b. Projected Monitoring Period: <input type="checkbox"/> 5 years <input type="checkbox"/> 10 years	
10. Calculation of Emissions:			
11. Potential, Fugitive, and Actual Emissions Comment:			

**F2. EMISSIONS UNIT POLLUTANT DETAIL INFORMATION -
ALLOWABLE EMISSIONS**

Complete Subsection F2 if the pollutant identified in Subsection F1 is or would be subject to a numerical emissions limitation.

Allowable Emissions Allowable Emissions ____ of ____

1. Basis for Allowable Emissions Code:	2. Future Effective Date of Allowable Emissions:
3. Allowable Emissions and Units:	4. Equivalent Allowable Emissions: lb/hour tons/year
5. Method of Compliance:	
6. Allowable Emissions Comment (Description of Operating Method):	

Allowable Emissions Allowable Emissions ____ of ____

1. Basis for Allowable Emissions Code:	2. Future Effective Date of Allowable Emissions:
3. Allowable Emissions and Units:	4. Equivalent Allowable Emissions: lb/hour tons/year
5. Method of Compliance:	
6. Allowable Emissions Comment (Description of Operating Method):	

Allowable Emissions Allowable Emissions ____ of ____

1. Basis for Allowable Emissions Code:	2. Future Effective Date of Allowable Emissions:
3. Allowable Emissions and Units:	4. Equivalent Allowable Emissions: lb/hour tons/year
5. Method of Compliance:	
6. Allowable Emissions Comment (Description of Operating Method):	

EMISSIONS UNIT INFORMATION

Section [2]

Misc Unregulated Emissions

G. VISIBLE EMISSIONS INFORMATION

Complete Subsection G if this emissions unit is or would be subject to a unit-specific visible emissions limitation.

Visible Emissions Limitation: Visible Emissions Limitation 1 of 2

1. Visible Emissions Subtype: VE05	2. Basis for Allowable Opacity: <input checked="" type="checkbox"/> Rule <input type="checkbox"/> Other
3. Allowable Opacity: Normal Conditions: 5 % Exceptional Conditions: % Maximum Period of Excess Opacity Allowed: 6 min/hour	
4. Method of Compliance: EPA Method 9	
5. Visible Emissions Comment: 40 CFR 60, Subpart Cb VE test required for ash conveying system	

Visible Emissions Limitation: Visible Emissions Limitation 2 of 2

1. Visible Emissions Subtype: VE05	2. Basis for Allowable Opacity: <input checked="" type="checkbox"/> Rule <input type="checkbox"/> Other
3. Allowable Opacity: Normal Conditions: 5 % Exceptional Conditions: % Maximum Period of Excess Opacity Allowed: 6 min/hour	
4. Method of Compliance: EPA Method 9	
5. Visible Emissions Comment: 40 CFR 60, Subpart BBBB VE test required for ash conveying system	

EMISSIONS UNIT INFORMATION

Section [2]

Misc Unregulated Emissions

H. CONTINUOUS MONITOR INFORMATION

Complete Subsection H if this emissions unit is or would be subject to continuous monitoring.

Continuous Monitoring System: Continuous Monitor ____ of ____

1. Parameter Code:	2. Pollutant(s):
3. CMS Requirement:	<input type="checkbox"/> Rule <input type="checkbox"/> Other
4. Monitor Information... Manufacturer: Model Number: Serial Number:	
5. Installation Date:	6. Performance Specification Test Date:
7. Continuous Monitor Comment:	

Continuous Monitoring System: Continuous Monitor ____ of ____

1. Parameter Code:	2. Pollutant(s):
3. CMS Requirement:	<input type="checkbox"/> Rule <input type="checkbox"/> Other
4. Monitor Information... Manufacturer: Model Number: Serial Number:	
5. Installation Date:	6. Performance Specification Test Date:
7. Continuous Monitor Comment:	

EMISSIONS UNIT INFORMATION

Section [2]

Misc Unregulated Emissions

I. EMISSIONS UNIT ADDITIONAL INFORMATION

Additional Requirements for All Applications, Except as Otherwise Stated

1. Process Flow Diagram: (Required for all permit applications, except Title V air operation permit revision applications if this information was submitted to the department within the previous five years and would not be altered as a result of the revision being sought) <input checked="" type="checkbox"/> Attached, Document ID: <u>BC-EU2-11</u> <input type="checkbox"/> Previously Submitted, Date _____
2. Fuel Analysis or Specification: (Required for all permit applications, except Title V air operation permit revision applications if this information was submitted to the department within the previous five years and would not be altered as a result of the revision being sought) <input type="checkbox"/> Attached, Document ID: _____ <input type="checkbox"/> Previously Submitted, Date _____
3. Detailed Description of Control Equipment: (Required for all permit applications, except Title V air operation permit revision applications if this information was submitted to the department within the previous five years and would not be altered as a result of the revision being sought) <input type="checkbox"/> Attached, Document ID: _____ <input type="checkbox"/> Previously Submitted, Date _____
4. Procedures for Startup and Shutdown: (Required for all operation permit applications, except Title V air operation permit revision applications if this information was submitted to the department within the previous five years and would not be altered as a result of the revision being sought) <input type="checkbox"/> Attached, Document ID: _____ <input type="checkbox"/> Previously Submitted, Date _____ <input type="checkbox"/> Not Applicable (construction application)
5. Operation and Maintenance Plan: (Required for all permit applications, except Title V air operation permit revision applications if this information was submitted to the department within the previous five years and would not be altered as a result of the revision being sought) <input type="checkbox"/> Attached, Document ID: _____ <input type="checkbox"/> Previously Submitted, Date _____ <input checked="" type="checkbox"/> Not Applicable
6. Compliance Demonstration Reports/Records: <input type="checkbox"/> Attached, Document ID: _____ Test Date(s)/Pollutant(s) Tested: _____ <input checked="" type="checkbox"/> Previously Submitted, Date: <u>January 2009</u> Test Date(s)/Pollutant(s) Tested: <u>VE on ash building</u> <input checked="" type="checkbox"/> To be Submitted, Date (if known): <u>February 2010</u> Test Date(s)/Pollutant(s) Tested: <u>VE on ash building</u> <input type="checkbox"/> Not Applicable Note: For FESOP applications, all required compliance demonstration records/reports must be submitted at the time of application. For Title V air operation permit applications, all required compliance demonstration reports/records must be submitted at the time of application, or a compliance plan must be submitted at the time of application.
7. Other Information Required by Rule or Statute: <input type="checkbox"/> Attached, Document ID: _____ <input checked="" type="checkbox"/> Not Applicable

ATTACHMENT BC-EU2-11
PROCESS FLOW DIAGRAM

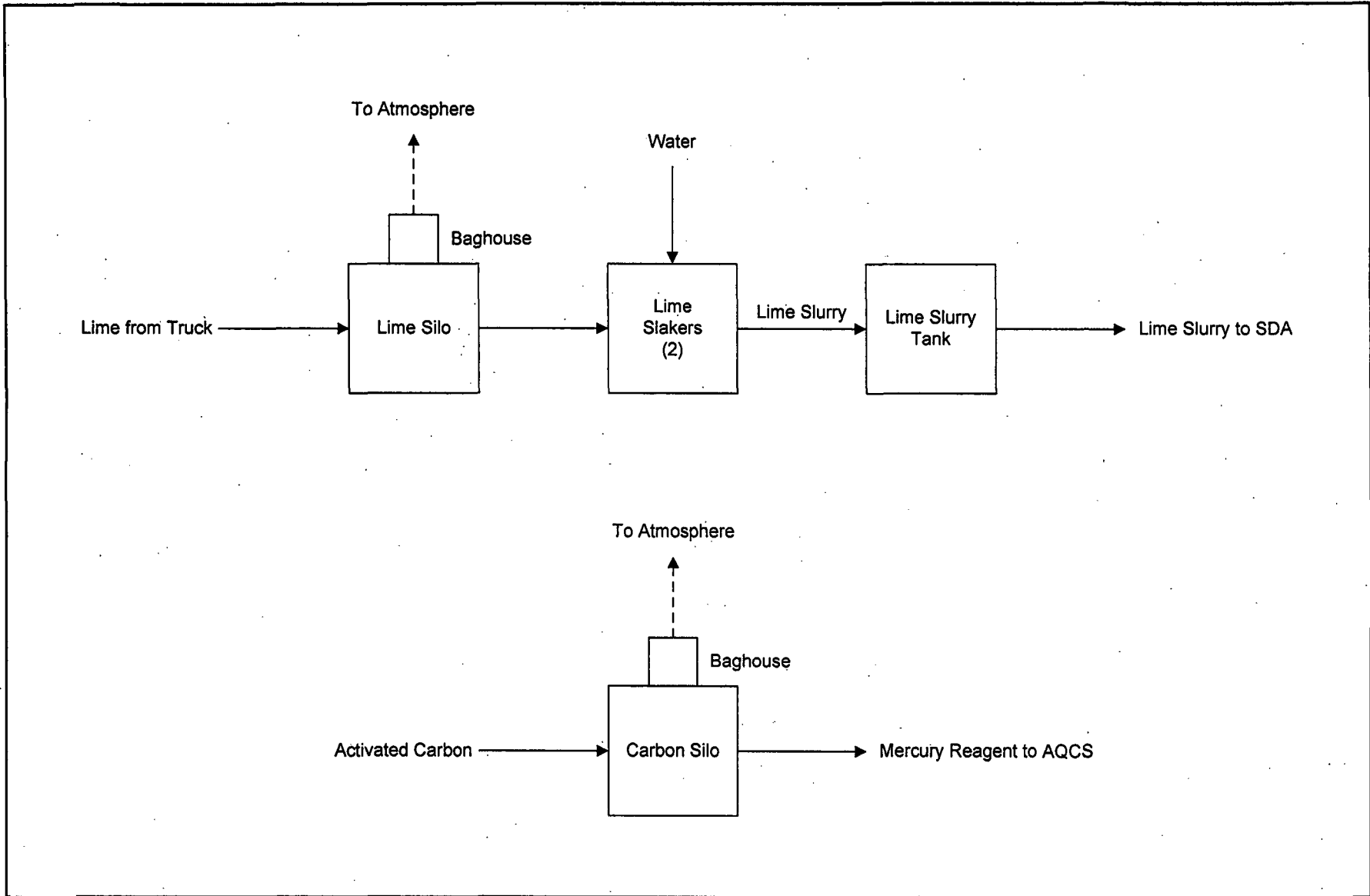

Attachment BC-EU2-11
Process Flow Diagram Detail
Lime Silos and Carbon Silos
Bay County Waste-to-Energy Facility

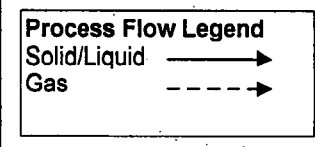

ATTACHMENT A

Table of Contents

- 1.0 INTRODUCTION 1
- 2.0 PROJECT DESCRIPTION 3
 - 2.1 Existing Operations 3
 - 2.2 Proposed Operations 5
 - 2.3 Air Pollution Control Equipment 6
- 3.0 PSD REVIEW 7
 - 3.1 PSD Review Requirements 7
 - 3.2 New Source Performance Standards Applicability 9
- 4.0 AIR EMISSIONS 11
 - 4.1 Baseline Actual Emissions 11
 - 4.1.1 SO₂, NO_x, and CO 13
 - 4.1.2 PM/PM₁₀/PM_{2.5}, Pb, Hg, HCl, D/F 14
 - 4.1.3 Volatile Organic Compounds 16
 - 4.1.4 Sulfuric Acid Mist 16
 - 4.1.5 Fluorides 17
 - 4.2 Projected Actual Emissions (Initial) 17
 - 4.3 Post-Change Actual Emissions (Without Proposed Project) 18
 - 4.4 Demand Growth Emissions 19
 - 4.5 Projected Actual Emissions (Final) 19
 - 4.6 Effects on Other Emissions Units 19
 - 4.7 PSD Review 19

List of Tables

- Table 3-1 PSD Significant Emission Rates
- Table 4-1 Baseline Actual Emissions
- Table 4-2 Projected Actual Emissions (Initial)
- Table 4-3 Post-Change Actual Emissions (Without Proposed Project)
- Table 4-4 Demand Growth Exclusion Calculation
- Table 4-5 PSD Applicability Analysis, Re-rate Project

List of Appendices

- Appendix A Baseline Actual Emissions Calculations for MWC Unit Nos. 1 and 2
- Appendix B Emission Factors from Annual Operating Reports
- Appendix C Permit History for the Bay County Waste-to-Energy Facility
- Appendix D Additional References for the Emission Factors

1.0 INTRODUCTION

Bay County Utility Services Department (Bay County) operates the Bay County Waste-to-Energy (BCWTE) facility, located at 6510 Bay Line Drive in Panama City, Bay County. The facility is currently operating under Title V operating permit No. 0050031-010-AV, effective August 1, 2005. The BCWTE facility includes two identical municipal waste combustor (MWC) units that utilize mass burn rotary waterwall technology. Each MWC unit at the facility is permitted for a municipal solid waste (MSW) charging rate of 245 tons per day (TPD). [Note: All references to MSW charging capacity in this application are based upon 4,500 British thermal units per pound (Btu/lb) of MSW.] Bay County is now proposing to re-rate the MWC units back to their original designed charging capacity of 255 TPD MSW per unit.

Bay County is also submitting this application for renewal of the Title V operating permit. It is requested that the air construction permit application and the Title V air operation permit renewal be processed concurrently.

The facility was constructed under the Florida Department of Environmental Protection (FDEP) permits AC 03-84703 and AC 03-84704, issued September 24, 1984. The emission units' initial startup date was May 1, 1987. The original control equipment for the MWC units included an electrostatic precipitator (ESP) on each unit. DEP permits AC 03-145061, AC 03-152196, and PSD-FL-129 were issued October 14, 1988 to increase the MSW throughput to 255 tons per day (TPD) per unit, or a total of 510 TPD for the facility.

On December 19, 1995, the U.S. Environmental Protection Agency (EPA) promulgated New Source Performance Standards (NSPS) contained in Title 40, Part 60 of the Code of Federal Regulations (40 CFR 60), Subpart Cb, "Emission Guidelines and Compliance Times for Municipal Waste Combustors That are Constructed on or Before December 19, 1995." This final rule required MWC units with a combustion capacity greater than 250 TPD MSW to comply with new emission limits.

At the time of the promulgation of Subpart Cb in 1995, Bay County did not desire to incur the large expense (and cost to the taxpayers) of complying with the Subpart Cb emission guidelines. Therefore, Bay County requested that the units be de-rated to 245 TPD MSW per unit. This request was granted by EPA and FDEP, and Title V air operation permit No. 0050031-002-AV was issued on August 1, 2000, incorporating new operating limitations that would allow the facility to be de-rated from 255 TPD to 245 TPD. By de-rating the MWC units, the facility did not become subject to Subpart Cb, and the cost of physical and operational changes associated with the rule was avoided.

Subsequent to these actions, in December 2000, EPA promulgated "Emission Guidelines and Compliance Times for Small Municipal Waste Combustion Units Constructed on or Before August 30, 1999" under 40 CFR 60, Subpart BBBB. These rules required compliance with new emission limits no later than

December 2005. In order to meet these emission limits, Bay County replaced the existing ESP on each unit with new control equipment, consisting of a lime spray dryer, baghouse, and carbon injection system.

Since the Subpart BBBB emission guidelines required Bay County to install new air pollution control equipment, they already have in place adequate equipment to meet the Subpart Cb guidelines for larger MWC units. The MWC units were originally designed for 255 TPD MSW, and Bay County desires to regain the capacity lost when the de-rate took place. Bay County has an adequate MSW stream to supply the additional MSW tonnage to the facility. Increasing the rating and permitted capacity of the units will allow Bay County to achieve its goals of providing Bay County residents with cost-effective, long-term waste disposal services. Therefore, Bay County is now proposing to re-rate the MWC units back to their original charging capacity of 255 TPD MSW per unit.

Bay County has performed a comparison of past actual (baseline actual) annual emissions to projected actual annual emissions for the re-rate project, based on the new source review (NSR) reform rules. Due to the nature of this comparison, emission increases due to the project are predicted for some pollutants; however, these increases are less than the prevention of significant deterioration (PSD) significant emission rates. Therefore, the project will not trigger NSR under the Federal and State PSD regulations.

A more detailed project description is provided in Section 2.0 of this attachment. PSD review requirements are discussed in Section 3.0, and air emissions estimates and the PSD applicability of the project are presented in Section 4.0.

2.0 PROJECT DESCRIPTION

Bay County is proposing to re-rate the MWC units at the BCWTE facility to their original charging capacity of 255 TPD of MSW per unit (4,500 Btu/lb MSW basis). The MWC Units Nos. 1 (North) and No. 2 (South) have emission unit (EU) numbers 001 and 002, respectively. The following sections describe the existing units and the proposed project in more detail.

2.1 Existing Operations

The BCWTE is designed to receive and process sufficient MSW to combust up to 510 TPD of MSW in two rotary combustors (boilers), based on the original facility design. A facility flow diagram is presented in Attachment BC-FI-C2 of the permit application form. Solid waste collection vehicles hauling the material to be processed are weighed at the scale prior to entering the plant, and are then directed to the tipping floor in the MSW receiving building. The tipping floor is sized to accommodate approximately 4,000 tons of waste, while allowing room to maneuver the incoming trucks and front-end loaders. From this point on, the process takes place in one of the two "identical" trains (combustor; boiler; air pollution control system; APC; stack).

The solid waste is spread out over the floor where it is well mixed and any oversized or prohibited materials are removed from the waste stream. It is then pushed onto a horizontal apron (loading) conveyor by the front-end loader operator. The loading conveyor transfers the waste to an inclined apron (incline) conveyor, from which the waste is dropped into the combustor charging chute. For emergency cases, such as one line of feed conveyors down for maintenance, a transfer (crossfeed) conveyor at the charging chute level can feed both combustors from either incline conveyor by changing the position of a pair of diverters. From the feed chute the waste is pushed into the combustor by hydraulic ram feeders (rams). The speed of the rams and the amount of waste fed to the combustor is controlled by a setpoint in the control system.

Once the MSW enters the combustor, the combustion process begins. Three stages of combustion can be distinguished during the process:

- The first zone is the drying process. In this stage, the heat from the combustor together with the hot combustion air supplied through the wind box drive the moisture out of the MSW. At the same time, the MSW temperature (temp) is raised until volatile gases are released. The incineration process begins when the MSW ignites.
- The second zone is the combustion process. In this stage, combustion air is supplied to the burning MSW to maintain the optimum conditions for combustion. The combustion gas temperature in the second stage reaches 1800 degrees Fahrenheit (°F) or higher. Because of the mixed consistency of MSW, most of the MSW is burned in this stage while the remaining material burns during the next stage.
- The third zone is the burn out phase. In this stage the burning process is essentially completed. Tumbling, burning residue leaves the combustor and drops onto the ash residue grates and then to the ash drag system. Supplemental air sent to the grates helps complete the combustion of any remaining portion of combustibles in the residue.

After combustion, the residue falls through a "bifurcating" chute into a water submerged drag conveyor. A quench basin removes heat from the ash and provides a seal between the boiler furnace and the ash removal system. Heat is exhausted from the combustor with the combustion gases. Part of the heat is recuperated by a feedwater economizer and a combustion air heater. The flue gases leaving the boiler pass through the pollution control equipment, consisting of a spray dryer absorber (SDA), where lime slurry, air, and scrubber water are injected through five nozzles to control the baghouse inlet temperature, sulfur dioxide (SO₂), and hydrogen chloride (HCl). The gases then pass through a five-compartment baghouse and out the stack.

Flyash is collected in hoppers at each air heater, SDA, and baghouse cell. The flyash is then transferred by a pneumatic conveying system to the boiler bottom ash conveyor where it is mixed with bottom ash. The mixed wet ash is then conveyed to the ash building.

The heat of combustion in the combustors is used to transform the water into steam by the steam generating equipment (combustor-boiler). The steam generated is used by the turbine generator to produce electricity with a small amount being used for plant services. The rotary combustor, boiler, turbine, condenser, feed system, and associated pipes form a closed cycle for the water to be transformed into steam, then condensed and returned to the boiler to re-enter the steam cycle.

The boiler control system attempts to adjust the combustion rate in each furnace to maintain a fairly steady steam flow, but because of the highly variable nature of MSW, the combustion rate cannot be precisely controlled. For this reason, steam flow will vary, so the turbine throttle valve will act as a backpressure regulator, increasing or decreasing the flow to maintain constant upstream pressure.

The changes in steam flow to the turbine will cause variation in the power output of the generator. The generator, when running on the utility grid, will normally be able to use all the steam available from the boilers. When the generator is operating independent of the grid, the governor will regulate the steam flow to maintain plant consumption requirements. The combustion rate and hence the steam flow from the boilers will still vary, and the steam flow will normally exceed the power requirements of the turbine generator.

A flow diagram of MWC Unit Nos. 1 and 2 is presented in Attachment BC-EU1-11 of the permit application form. Each unit consists of a combustor, a furnace (waterwall tubes), a superheater, steam and mud drum, a forced circulation system, an economizer, an air heater, air pollution control system, ash removal system, and a stack.

Both MWCs are coupled to a common electric generator with a nameplate rating of 15 megawatts of electricity. In addition to MSW, the MWC units are permitted to burn wood waste, and utilize natural gas as an auxiliary fuel.

MWC Unit Nos. 1 and 2 are each currently limited to the following:

- MSW Input Rate: 245 TPD (a total of 490 TPD for the facility)
- Heat Input Rate: 91.875 million British thermal units per hour (MMBtu/hr) (assuming a heating value of 4,500 Btu/lb)
- Steam Flow Rate: 65,333 pounds per hour (lb/hr) over any 24-hour average rolling period and 66,667 lb/hr over any 4-hour block
- Hours of Operation: Continuous operation allowed, i.e., 8,760 hr/yr

2.2 Proposed Operations

Bay County is proposing to re-rate the MWC units at the facility to their original charging capacity of 255 TPD of MSW per unit (at 4,500 Btu/lb). In order to accomplish the increase in capacity, the only physical change required to the units will be to replace the forced draft fan blades, which were changed when the facility was de-rated in 1999. Future operation of the unit at the higher rates may indicate new fan blades are necessary, or are desirable from an energy efficiency standpoint. New fan blades may be required in order to provide enough combustion air to the units. Also, changing the fan blades will increase the capacity of the fans to deliver combustion air to the boilers, which can allow the fans to operate at slower speeds, and thereby increase the energy efficiency of the fans.

No other physical changes to MWC Unit Nos. 1 and 2 are required in order to achieve the higher MSW combustion rate. All equipment, including fuel feed system, ash handling system, and air pollution control equipment, is capable of operating and meeting emission limits at the higher capacity.

The proposed operational parameters for each MWC unit at the higher capacity are provided below:

- MSW Input Rate: 255 TPD (a total of 510 TPD for the facility, assuming a heating value of 4,500 Btu/lb)
- Heat Input Rate: 95.6 MMBtu/hr (assuming a heating value of 4,500 Btu/lb)
- Steam Flow Rate: 68,000 lb/hr over any 24-hour average rolling period
- Hours of Operation: Continuous operation allowed, i.e., 8,760 hr/yr
- Maximum hourly rates for each unit are as follows, based on 110 percent of the 24-hour average:
 - MSW Input Rate: 11.7 tons per hour (TPH) MSW
 - Steam Flow Rate: 74,800 lb/hr steam
 - Heat Input Rate: 105.2 MMBtu/hr

In a letter to EPA dated October 14, 2009, Golder Associates Inc. (Golder) requested a determination regarding the applicability of the NSPS to this proposed Bay County re-rate project. It was requested that EPA determine if Subpart Cb or Subpart Eb (Standards of Performance for Large Municipal Waste Combustors for Which Construction is Commenced After September 20, 1994 or for Which Modification or Reconstruction is Commenced After June 19, 1996) would apply to the units after the re-rate. Both

Subparts Cb and Eb apply to MWC combustion units greater than 250 TPD MSW charging capacity, but Eb only applies to those units for which construction is commenced after September 20, 1994, or for which modification or reconstruction is commenced after June 19, 1996.

In a letter to FDEP dated December 14, 2009, EPA recommended that additional information regarding the facility's basis should be requested from Bay County. The requested information was provided by Golder to FDEP in a letter dated January 20, 2010, and FDEP forwarded the information to EPA. EPA responded to FDEP via email on January 28, 2010 (email from Dave McNeal, EPA Region 4, to Bruce Mitchell, FDEP), and concluded that the re-rated facility would be subject to Subpart Cb.

2.3 Air Pollution Control Equipment

The air quality control system (AQCS) consists of two identical trains, one for each operating boiler. Each train consists of a spray dryer absorber (SDA), three baghouse inlet thermocouples, a five cell baghouse, an induced draft (ID) fan, a continuous emissions monitoring system (CEMS), and a stack. Both trains are supplied by several common systems, including the lime, scrubber water, and carbon-feed systems.

- Lime: The lime system prepares lime slurry for use in the SO₂ and HCl neutralization process in a sufficient quantity and concentration to maintain continuous flue gas treatment in the SDA. The system has been designed for batch mixing to provide this service. A lime silo with baghouse control device is used for lime storage prior to slaking with water.
- SDA – Belco/Merrick. Untreated flue gas and reagent lime slurry combine in the SDA, resulting in the neutralization and removal of the acid components contained in the gas stream. The two streams, lime slurry and boiler exhaust gas, combine and result in a dry product and scrubbed gas exiting the absorber chamber.
- Fabric Filter Baghouse – Merrick. The baghouse is used to remove entrained particulate matter (flyash, acid gas reaction products, calcium salts, etc.) from the flue gas prior to exhausting to the atmosphere through the stack. The particulate matter is filtered from the flue gas as it passes through the fiberglass filter bags. In addition, some un-reacted lime accumulates on the filter bags, providing additional acid gas removal.
- Carbon Injection – Merrick. Carbon is injected in the flue gas stream at the inlet of the SDA for the removal of mercury (Hg). The system utilizes a loss of weight feeder to inject dry carbon into the inlet duct of the SDA.

A process flow diagram of the MWC units and the AQCS is presented in Attachment BC-EU1-11 of the application form. A process flow diagram of the lime and carbon silos is presented in Attachment BC-EU2-11.

The AQCS is already adequate to support the higher MSW combustion rates. No upgrades to this system will be required to meet emission limits.

3.0 PSD REVIEW

3.1 PSD Review Requirements

A PSD applicability analysis was conducted to demonstrate that the proposed project would not trigger PSD review. PSD review is used to determine whether significant air quality deterioration will result from a major new or modified facility. Federal PSD requirements are contained in 40 CFR 52.21, Prevention of Significant Deterioration of Air Quality. FDEP has adopted PSD regulations that are equivalent to the federal PSD regulations [Rule 62-212.400, Florida Administrative Code (F.A.C.)]. For an existing major stationary source for which a modification is proposed, the modification is subject to PSD review if the net increase in emissions due to the modification is greater than the PSD significant emissions rates (i.e., a "major modification"). The PSD significant emissions rates are listed in Table 3-1.

The determination of whether a significant net increase in emissions will occur is based on comparison of "baseline actual emissions" to "projected actual emissions" for all emissions units affected by the proposed project. "Baseline actual emissions" and "projected actual emissions" are defined in Rules 62-210.200(34) and (215), F.A.C. "Baseline actual emissions" for an existing emissions unit other than an electric utility steam generating unit, is the average rate, in tons per year (TPY), at which the emissions unit actually emitted the pollutant during any consecutive 24-month period, selected by the owner/operator, within the 10-year period immediately preceding the date a complete permit application is received by FDEP. The average rate includes fugitive emissions to the extent quantifiable and emissions associated with startups and shutdowns. The average rate must be adjusted downward to exclude:

- Any non-compliant emissions that occurred while the emissions units were operating above an emissions limitation that was legally enforceable during the consecutive 24-month period
- Any emissions that would have exceeded an emission limitation with which the major stationary source must currently comply, had such major stationary source been required to comply with such limitations during the consecutive 24-month period

For projects involving multiple emissions units, only one consecutive 24-month period can be used for all the emissions units being changed. However, a different 24-month period can be used for each PSD pollutant.

Rule 62-210.370, F.A.C., requires a specific methodology for computing baseline actual emissions and net emissions increases. In general, this rule sets forth a hierarchy of emission estimating methods, of which the most accurate method is to be used. CEMS are generally recognized as the most accurate method, followed by mass balance calculations, followed by emission factors. If stack test data are used, the emission factor shall be based on the average emissions per unit of input, output, or gas volume, whichever is appropriate, of all valid tests conducted during at least a 5-year period encompassing the

period over which the emissions are computed, provided all stack tests used shall represent the same operational and physical configuration of the unit.

"Projected actual emissions" is the maximum annual rate, in TPY, at which an existing emissions unit is projected to emit a regulated air pollutant in any one of the 5 years following the date the unit resumes regular operation after the project, or in any one of the 10 years following that date, if the project involves increasing the emissions unit's potential to emit that regulated air pollutant, and full utilization of the unit would result in a significant emissions increase or a significant net emissions increase at the facility.

In determining the projected actual emissions, FDEP shall consider all relevant information, including historical operating data, the company's own representations, the company's expected business activity, the company's filings with the state or federal regulatory authorities, and compliance plans or orders. Fugitive emissions, to the extent quantifiable, and emissions associated with startups and shutdowns shall be considered.

The projected actual emissions shall exclude that portion of the unit's emissions following the project that an existing unit could have accommodated during the consecutive 24-month period used to establish the baseline actual emissions, and that are also unrelated to the particular project, including any increased utilization due to demand growth (this is referred to as the "demand growth exclusion"). EPA's final PSD rule revisions, promulgated on December 31, 2002, state:

That is, under today's new provisions for non-routine physical or operational changes to existing emissions units, rather than basing a unit's post-change emissions on its PTE, you may project an annual rate, in TPY, that reflects the maximum annual emissions rate that will occur during any one of the 5 years immediately after the physical or operational change. ...This projection of the unit's annual emissions rate following the change is defined as the "projected actual emissions", and will be based on your maximum annual rate in tons per year at which you are projected to emit a regulated NSR pollutant, less any amount of emissions that could have been accommodated during the selected 24-month baseline period and is not related to the change. Accordingly, you will calculate the unit's projected actual emissions as the product of: (1) The hourly emissions rate, which is based on the operational capabilities following the change(s), taking into account legally enforceable restrictions that could affect the hourly emissions rate following the change(s); and (2) the projected level of utilization, which is based on both the emissions unit's historical annual utilization rate and available information regarding the emissions units' likely post-change capacity utilization. ...From the initial calculation, you may then make the appropriate adjustment to subtract out any portion of the emissions increase that could have been accommodated during the unit's 24-month baseline period and is unrelated to the change. [Federal Register, Vol. 67, pg. 80196]

Consequently, under today's new rules, when a projected increase in equipment utilization is in response to a factor such as the growth in market demand, you may subtract the emission increases from the unit's projected actual emissions if: (1) The unit could have achieved the necessary level of utilization during the consecutive 24 month period you selected to establish the baseline actual emission; and (2) the increase is not related to the physical or operational change(s) made to the unit. [Federal Register, Vol. 67, pg. 80203]

Further explanation was provided in the preamble to EPA's proposed PSD rule revisions on September 14, 2006:

That is, the source can emit up to its current maximum capacity without triggering major NSR under the actual-to-projected-actual test, as long as the increase is unrelated to the change. [Federal Register, Vol. 71, pg. 54237]

Post-change emissions are generally projected using the emissions unit's maximum annual rate, in tons per year, at which it is expected to emit a regulated NSR pollutant within 5 years following a change, less any amount of emissions that the unit could have accommodated during the selected 24-month baseline period and that are unrelated to the change. This final "projected actual" value, in tons per year, is the value you compare to the "baseline actual emissions" in order to determine...whether the proposed project will result in a "significant" emissions increase, as defined in the first step of the calculation. [Federal Register, Vol. 71, pg. 54238]

If the proposed modification results in a significant emissions increase for any PSD pollutant, then all contemporaneous increases or decreases in emissions of that pollutant that have occurred at the facility in the last 5 years must also be considered.

The Bay County facility is an existing major stationary facility because potential emissions of at least one PSD-regulated pollutant exceed 100 TPY [for example, potential nitrogen oxides (NO_x) emissions currently exceed 100 TPY]. Therefore, PSD review is required for any pollutant for which the net increase in emissions due a modification at the facility is greater than the PSD significant emissions rates (see Table 3-1). If a modification meets these criteria, it is deemed a "major modification."

3.2 New Source Performance Standards Applicability

MWC Unit Nos. 1 and 2 are already subject to the NSPS for Small Municipal Waste Combustion Units Constructed on or Before August 30, 1999, contained in 40 CFR 60, Subpart BBBB. The cost of replacement of the fan blades for both units, if required, is estimated at \$45,640. This represents less than 0.2 percent of the existing facility's basis of \$12 million. This percentage is much less than the criteria that define a capital expenditure (i.e., 15 percent or more of the existing facility's basis). Therefore, the proposed re-rate project does not constitute a modification for purposes of the NSPS. As a result, the NSPS for Municipal Waste Combustors Constructed on or Before December 19, 1995, contained in 40 CFR 60, Subpart Cb, would apply to the facility after the re-rate is implemented. As previously described in Section 2.2, EPA has confirmed this determination in an email dated January 28, 2010, to FDEP.

Based on the applicability of 40 CFR Subpart Cb to the re-rated facility, Bay County requests that all applicable requirements of Subpart Cb be incorporated into the facility's Title V air operating permit. This will include the requirements of §60.38b(a), which refers to the performance testing methods listed in §60.58b of Subpart Eb. §60.58b(a) states that the duration of startup, shutdown, or malfunction periods are limited to 3 hours per occurrence. In addition, for the purposes of compliance with the CO emission

limits, if a loss of boiler water level control (e.g., boiler waterwall tube failure) or a loss of combustion air control (e.g., loss of combustion air fan, induced draft fan, combustion grate bar failure) is determined to be a malfunction, the duration of the malfunction period is limited to 15 hours per occurrence.

4.0 AIR EMISSIONS

4.1 Baseline Actual Emissions

The baseline actual annual average emissions for MWC Unit Nos. 1 and 2 are presented in Table 4-1. The basis of the emissions estimates are presented in Appendix A. Based on recently adopted Florida PSD reform rules, the baseline actual emissions may be based on a consecutive 24-month period out of the last 10 years (2000 to 2009). Actual emissions for each of the last 9 years available (2000 to 2008) were determined based on operating data, available stack test data, and emission factors. Operating data were not yet available for 2009; therefore, only a 9-year period was considered for the baseline actual emissions. For each pollutant, the consecutive 2-year period with the highest average combined TPY emissions was selected as the baseline actual emissions for MWC Unit Nos. 1 and 2. The 2-year averages used for each pollutant are as follows:

Pollutant	2-Year Average Baseline
Sulfur Dioxide – SO ₂	2002 to 2003
Nitrogen Oxides – NO _x	2002 to 2003
Carbon Monoxide – CO	2002 to 2003
Particulate Matter – PM	2002 to 2003
Particulate Matter under 10 microns in diameter – PM ₁₀	2002 to 2003
Particulate Matter under 2.5 microns in diameter – PM _{2.5}	2002 to 2003
Volatile Organic Compounds – VOCs	2002 to 2003
Sulfuric Acid Mist – SAM	2002 to 2003
Lead – Pb	2002 to 2003
Mercury – Hg	2002 to 2003
Fluorides – F	2005 to 2006
Hydrogen Chloride – HCl	2002 to 2003
MWC – Acid Gases (SO ₂ + HCl)	2002 to 2003
MWC – Organics – Dioxins/Furans (D/F)	2002 to 2003

The baseline actual emissions for MWC Unit Nos. 1 and 2 shown in Appendix A, Table A-3, may differ from the annual emissions shown in the Annual Operating Reports (AORs) submitted to FDEP by Bay County, as described below.

The emission factors reported for each pollutant in the AOR submitted to FDEP are presented in Appendix B, Tables B-1 and B-2. MWC Unit Nos. 1 and 2 operating data are presented in Appendix A, Tables A-11 and A-12. The revised emission factors used for determining the baseline actual emissions are shown in Appendix A, Tables A-1 and A-2. The emission factors used in the previous AORs were revised to reflect any current AP-42 emission factors, as well as the emissions reporting hierarchy required by Rule 62-210.370, F.A.C. The revised emission factors for PM, lead (Pb), Hg, HCl, dioxins/furans (D/F), carbon monoxide (CO), NO_x, SO₂, volatile organic compounds (VOCs), and fluoride (F), were based on the historic stack test data and CEMS data available from MWC Unit Nos. 1 and 2.

The Florida rules require that, if stack test data are used, the emission factor shall be based on the average emissions per unit of input, output, or gas volume, whichever is appropriate, of all valid tests conducted during at least a 5-year period encompassing the period over which the emissions are computed, provided all stack tests used shall represent the same operational and physical configuration of the unit. However, in this analysis, less than a 5-year average may have been used in some cases (as explained further below), since the available stack test data still represents the best emission factor.

To determine the operational and physical configuration of MWC Unit Nos. 1 and 2 for each year during the years 2000 to 2008, the permitting files were researched. It was concluded that MWC Unit Nos. 1 and 2 have had two different sets of operational/physical configurations over the years 2000 through 2008. This change occurred in mid-2005, when new air pollution control equipment was installed on both units.

Therefore, available stack test data encompassing the reporting years were averaged over 5-year periods (when available) before and after the operational change in order to obtain representative emission factors. Refer to Appendix A, Tables A-6 through A-9, and the discussion below for further information.

Note that in this analysis, for the year 2005, stack tests representative of the new air pollution control equipment installed in mid-2005 were used to develop emission factors. These emission factors were applied to the entire 2005 annual period. Thus, the baseline emissions for 2005 are lower than actually occurred, which makes the PSD applicability analysis conservative.

Rule 62-210(36), F.A.C., which is the definition of "baseline actual emissions," requires that the emissions be adjusted downward to exclude any emissions that would have exceeded an emission limitation with which the major stationary source must currently comply, had such major stationary source been required to comply with such limitations during the consecutive 24-month period. The current maximum permitted emission rates for the MWC units, as required by 40 CFR 60, Subpart BBBB, as well as the State of Florida emission standard for Hg, are described below and are also shown in Attachment BC-EU1-F1.10b of the application form. Any stack tests that resulted in an emission rate above the current limits must be reduced to the current limit value. As shown in Tables A-6 through A-9, stack tests for several pollutants for both units for the period prior to 2005 were adjusted to reflect current limits. See Attachment C for a permitting history table of the BCWTE facility.

The resulting baseline actual emissions for each pollutant for each year, based on the revised emission factors, are presented in Appendix A, Tables A-3 and A-4. The resulting 2-year average emissions for each 2-year period during 2000 to 2008 are presented in Appendix A, Table A-5. The highest 2-year average for each pollutant represents the baseline actual emissions (see Table 4-1 and Appendix A, Table A-5). Emission factor documentation other than stack test data is provided in Appendix D.

4.1.1 SO₂, NO_x, and CO

MWC Unit Nos. 1 and 2 burn MSW, while very small amounts of natural gas are burned at times. The SO₂ emission factors used in the past AOR reporting for MSW burning were either:

- Values ranging from 11.93 to 28.55 lb/hr for MWC Unit No. 1 and from 12.70 to 25.28 lb/hr for MWC Unit No. 2, based on stack test data for the 2000 to 2005 period (see Appendix B, Table B-1)
- CEMS data ranging from 0.19 to 0.29 pound per ton (lb/ton) of MSW for MWC Unit No. 1 and from 0.07 to 0.48 lb/ton of MSW for MWC Unit No. 2, reported for the 2006 to 2008 period

The NO_x emission factors used in the past AOR reporting for MSW burning were either:

- Values ranging from 15.76 to 21.88 lb/hr for MWC Unit No. 1 and from 20.42 to 23.64 lb/hr for MWC Unit No. 2, based on stack test data for the 2000 to 2005 period (see Appendix B, Tables B-1 and B-2)
- CEMS data ranging from 2.35 to 2.80 lb/ton of MSW for MWC Unit No. 1 and from 3.19 to 3.71 lb/ton of MSW for MWC Unit No. 2, reported for the 2006 to 2008 period

The CO emission factors used in the past AOR reporting for MSW burning were either:

- Values ranging from 9.94 to 43.28 lb/hr for MWC Unit No. 1 and from 12.75 to 43.51 lb/hr for MWC Unit No. 2, based on stack test data for the 2000 to 2005 period (see Appendix B, Table B-1)
- CEMS data ranging from 1.70 to 2.35 lb/ton of MSW for MWC Unit No. 1 and from 2.22 to 2.78 lb/ton of MSW for MWC Unit No. 2, reported for the 2006 to 2008 period

Prior to 2005, only stack testing was performed at the BCWTE facility and no CEMS were utilized. Beginning in late 2005, CEMS were installed and operational. The CEMS installation coincided with the installation of new control equipment in 2005.

Rule 62-210.370(2)(d)1.a., F.A.C., requires that when using annual stack test results to calculate baseline actual emissions, a minimum 5-year period that encompasses the 2-year period for which emissions estimates are being made must be used, if adequate data are available. To comply with this requirement, to determine actual emissions for 2000 to 2004, available stack tests for the year 1999 and the subsequent 5 years (1999 to 2004) for each unit were used (see Appendix A, Tables A-7 and A-9). Using the average SO₂, NO_x, and CO emissions in lb/hr from the stack tests, and the steam production rate in thousand lb/hr, emission factors in pounds per thousand pounds (lb/10³ lb) of steam were calculated for each test. The average emission factor for all available tests over this period was then determined for each pollutant.

One SO₂ stack test was conducted on each unit in 2005, representative of the new air pollution control equipment. These tests were used to develop the emission factor for each unit for the year 2005.

CO and NO_x emissions were not affected by the installation of the new control equipment in 2005. Therefore, all stack tests from the period 1999 to 2005 were utilized to develop the emission factors for the period 2000 to 2005, prior to the installation of the CEMS.

Using the annual steam production, the annual emissions for 2000 for each of the MWC units was then determined (see Appendix A, Tables A-1 through A-4). This process was repeated for the 2000 to 2005 period to determine the annual SO₂, NO_x, and CO emissions for each year.

For the 2006 to 2008 period, the CEMS values in parts per million by volume, dry (ppmvd) were used with the annual total gas flow rate [dry standard cubic feet per year (dscf/yr) corrected to 7-percent oxygen] to calculate the total emissions of SO₂, NO_x, and CO in pounds per year (lb/yr). The emission factor in lb/10³ lb of steam was then determined by dividing the annual total emissions by the annual steam production rate (see Appendix A, Table A-10). The annual emissions from the CEMS for each of the MWC are shown in Appendix A, Tables A-1 through A-4.

The SO₂ emission factor used in the past AOR reporting from natural gas burning was 0.60 pound per million standard cubic feet (lb/10⁶ scf) based on AP-42, Table 1.4-2; the NO_x emission factor was 100 lb/10⁶ scf based on AP-42, Table 1.4-1; and the CO emission factor was 84 lb/10⁶ scf based on AP-42, Table 1.4-1 (see Appendix B, Tables B-1 and B-2). These factors were used in the revised emission factors tables (Appendix A, Tables A-1 and A-2).

The annual emissions due to MSW burning and natural gas burning were added to determine the total annual emissions for each year. Emissions for the 2-year period of 2002 to 2003 were selected for the baseline actual SO₂, NO_x, and CO emissions (see Table 4-1 and Appendix A, Table A-3).

4.1.2 PM/PM₁₀/PM_{2.5}, Pb, Hg, HCl, D/F

The PM emission factors used in the past AOR reporting for MSW burning were either:

- Values ranging from 1.20 to 4.15 lb/hr for MWC Unit No. 1 and from 2.10 to 3.87 lb/hr for MWC Unit No. 2, based on stack test data for the 2000 to 2005 period (see Appendix B, Tables B-1 and B-2)
- After new control equipment was installed in June 2005, PM emission factors ranged from 0.11 to 0.16 lb/ton of MSW for MWC Unit No. 1 and from 0.067 to 0.11 lb/ton of MSW for MWC Unit No. 2 for the 2006 to 2008 period (see Appendix B, Tables B-1 and B-2)
- PM₁₀ was assumed to be 100 percent of PM emissions; PM_{2.5} emissions were not reported

The Pb emission factors used in the past AOR reporting for MSW burning were either:

- Values ranging from 0.070 to 0.23 lb/hr for MWC Unit No. 1 and from 0.069 to 0.028 lb/hr for MWC Unit No. 2, based on stack test data for the 2000 to 2005 period (see Appendix B, Tables B-1 and B-2)

- After new control equipment was installed in June 2005, Pb emission factors ranged from 0.00025 to 2.0×10^{-5} lb/ton of MSW for MWC Unit No. 1 and from 1.6×10^{-4} to 4.8×10^{-5} lb/ton of MSW for MWC Unit No. 2 for the 2006 to 2008 period (see Appendix B, Tables B-1 and B-2)

The Hg emission factors used in the past AOR reporting for MSW burning were either:

- Values ranging from 0.0051 to 0.0034 lb/hr for MWC Unit No. 1 and from 0.0080 to 0.0037 lb/hr for MWC Unit No. 2, based on stack test data for the 2000 to 2005 period (see Appendix B, Tables B-1 and B-2)
- After the new control equipment was installed in June 2005, Hg emission factors ranged from 8.2×10^{-5} to 2.5×10^{-5} lb/ton of MSW for MWC Unit No. 1 and from 5.9×10^{-5} to 1.7×10^{-5} lb/ton of MSW for MWC Unit No. 2 for the 2006 to 2008 period (see Appendix B, Tables B-1 and B-2)

The HCl emission factor used in the past AOR reporting is based on a 1989 compliance test of 55.78 lb/hr. This emission factor was used for both MWC units from 2000 to 2005. After the new control equipment was installed in June 2005, HCl emission factors ranged from 0.17 to 0.028 lb/ton of MSW for MWC Unit No. 1 and from 0.11 to 0.058 lb/ton of MSW for MWC Unit No. 2 for the 2006 to 2008 period (see Appendix B, Tables B-1 and B-2).

Emissions of D/F have only been reported since 2006, after the emission units became subject to 40 CFR 60, Subpart BBBB. The emission factors have ranged from 0 to 2.0×10^{-6} lb/ton for MWC Unit No. 1 and have been reported as 0.0 lb/ton for MWC Unit No. 2, based on compliance stack test data for the 2006 to 2008 period (see Appendix B, Tables B-1 and B-2).

As previously stated, Rule 62-210.370(2)(d)1.a., F.A.C., requires that when using annual stack test results to calculate baseline actual emissions, a minimum 5-year period that encompasses the period for which emissions estimates are being made must be used, if adequate data are available. To comply with this requirement, available stack tests for the year 1999 and the subsequent 5 years (1999 to 2004) for each unit were used to determine actual emissions for 2000 to 2004 (see Appendix A, Tables A-6 and A-8). For PM, Pb, and Hg, the average emissions in lb/hr from the stack tests and the steam production rate in thousand lb/hr were used to calculate the emission factors in $\text{lb}/10^3$ lb of steam for each test. The average emission factor for all available tests over this period was then determined for each pollutant.

Since only one test was reported in 2002 for HCl and D/F during the 2000 to 2004 period, the calculated emission factors in $\text{lb}/10^3$ lb of steam that year were used each year until the new control equipment was installed.

The process was repeated for each pollutant for the 2005 to 2008 period, using stack test data for the 2005 to 2008 period.

The PM, Pb, and HCl emission factors used in the past AOR reporting from natural gas burning were 7.60, 5.0×10^{-4} , and 0.00026 lb/10⁶ scf, respectively, based on AP-42, Table 1.4-2. These factors were used in the revised emission factors tables (Appendix A, Tables A-1 and A-2).

No HCl or D/F emissions have been reported in past AORs for natural gas burning and no emission factors exist for natural gas burning; therefore, no HCl or D/F emissions were calculated from natural gas burning for the baseline actual emissions (see Appendix B, Tables B-1 and B-2).

The PM₁₀ emission factors used in the past AOR reporting has been assumed to be the same as the PM emission factors for MWC Unit Nos. 1 and 2. PM_{2.5} emissions have not been reported in past AOR submissions. The revised PM₁₀ and PM_{2.5} emission factors used for all years were 54 percent of PM as PM₁₀ and 39 percent of PM as PM_{2.5} based on EPA's PM calculator.

The annual emissions due to MSW burning and natural gas burning were added to determine the total annual emissions for each year. Emissions for the 2-year period of 2002 to 2003 were selected for baseline actual emissions of each pollutant previously mentioned (see Table 4-1 and Appendix A, Table A-3).

4.1.3 Volatile Organic Compounds

The VOC emission factors used in the past AOR reporting for MSW burning were either:

- Values ranging from 2.99 to 0.99 lb/hr for MWC Unit No. 1 and from 3.53 to 0.55 lb/hr for MWC Unit No. 2, based on stack test data for the 2000 to 2005 period (see Appendix B, Tables B-1 and B-2)
- After new control equipment was installed in June 2005, VOC emission factors ranged from 0.078 to 0.046 lb/ton of MSW for MWC Unit No. 1 and from 0.046 to 0.031 lb/ton of MSW for MWC Unit No. 2 for the 2006 to 2008 period (see Appendix B, Tables B-1 and B-2)

Similarly to previously mentioned pollutants, the annual emissions for every year for both of the MWC units were determined using the stack tests and the steam production rate in thousand lb/hr (see Appendix A, Tables A-1, A-2, A-7, and A-9).

The PM emission factor used in the past AOR reporting from natural gas burning was 7.60 lb/10⁶ scf based on AP-42, Table 1.4-2 (see Appendix B, Tables B-1 and B-2). This factor was used in the revised emission factors table (Appendix A, Tables A-1 and A-2).

Emissions for the 2-year period of 2002 to 2003 were selected for the baseline actual VOC emissions (see Table 4-1 and Appendix A, Table A-3).

4.1.4 Sulfuric Acid Mist

Reporting of SAM emissions in the past AOR reporting has been based on the permit limit of 1.5 lb/hr and the annual hours of operation and the annual tons of MSW burned (see Appendix B, Tables B-1 and B-2).

No emission factor exists for SAM emissions from MSW combustion or natural gas burning. However, SAM emissions can be estimated from a method similar to fuel oil combustion where the ratio of sulfur trioxide (SO_3) to SO_2 emissions from AP-42, Table 1.3-1 (5.7/157) is multiplied by the ratio of the molecular weight of sulfuric acid (H_2SO_4) to SO_3 (98/80). This results in an emission factor of approximately 4.45 percent of the SO_2 emissions (see Appendix A, Tables A-1 and A-2). The calculated annual SO_2 emissions were used with this ratio to determine the annual SAM emissions from MWC Unit Nos. 1 and 2 (see Appendix A, Tables A-1 and A-2). Emissions for the 2-year period of 2002 to 2003 were selected for the baseline actual SAM emissions (see Table 4-1 and Appendix A, Table A-3).

4.1.5 Fluorides

The F emission factors used in the past AOR reporting were based on the 1999 compliance test for year 2000 through 2005 and on the 2005 compliance test for the 2006 to 2008 period. The MWC Unit No. 1 emission factors are 0.0077 lb/hr for 2000 to 2005 and 0.014 lb/hr divided by the annual total tons of MSW burned for 2006 to 2008. The MWC Unit No. 2 emission factors are 0.0073 lb/hr for 2000 to 2005 and 0.014 lb/hr divided by the annual total tons of MSW burned for 2006 to 2008.

The same stack test values, divided by the steam rate during the compliance stack test, were used for the revised emission factors in Tables A-1 and A-2.

No F emissions have been reported in past AORs for natural gas burning and no F emission factors exist for natural gas burning; therefore, no F emissions were calculated for natural gas burning for the baseline actual emissions.

Emissions for the 2-year period of 2005 to 2006 were selected for the baseline actual F emissions (see Table 4-1 and Appendix A, Table A-3).

4.2 Projected Actual Emissions (Initial)

"Projected actual emissions" for MWC Unit Nos. 1 and 2 were developed considering the operating factors and emission factors used for the baseline actual emissions, as well as projected changes in operation due to the proposed project. The primary changes due to the project will be the increase in MSW burning at the facility and in the commensurate steam production. This will potentially increase emissions from the units.

As described in Section 3.0, the initial calculation of the unit's projected actual emissions is based on the product of: (1) the hourly emissions rate, which is based on the operational capabilities following the change(s), taking into account legally enforceable restrictions that could affect the hourly emissions rate following the change(s); and (2) the projected level of utilization, which is based on both the emissions unit's historical annual utilization rate and available information regarding the emissions units' likely post-change capacity utilization.

The operating factors used to calculate the initial projected actual emissions were based on the proposed maximum steam rate of 68,000 lb/hr (24-hour average), and a 95-percent availability for each unit (equivalent to 8,322 hr/yr operation). This results in a maximum annual steam production rate of $565,896 \times 10^3$ lb of steam per unit. The historic maximum annual natural gas burned in each MWC unit was also utilized (see Tables A-11 and A-12). The maximum natural gas consumption of 22.24×10^6 scf was used for both MWC Unit Nos. 1 and 2.

To make the initial calculation of projected actual emissions, the emission factors for PM/PM₁₀/PM_{2.5}, VOC, Pb, Hg, HCl, SAM, F, and D/F were based on the highest stack test emission rate for each unit for stack tests conducted after the 2005 operational change, i.e., 2005 to 2008 test data (see Table 4-2 and Appendix A, Tables A-6 through A-9). Emission factors for SO₂, NO_x, and CO were based on the maximum CEMS emission rate experienced by each unit after the 2005 operational change (see Table 4-2 and Appendix A, Table A-10). The emission factors to calculate the projected actual emissions from natural gas burning were the same emission factors used to calculate the baseline actual emissions.

The resulting initial projected actual annual emissions for MWC Unit Nos. 1 and 2 are shown in Table 4-2.

From the initial calculation, the appropriate adjustment may be made to subtract out any portion of the emissions increase that could have been accommodated during the unit's 24-month baseline period and is unrelated to the change. In order to determine this adjustment, post-change actual emissions without the proposed project were developed.

4.3 Post-Change Actual Emissions (Without Proposed Project)

The "post-change actual emissions" without the proposed project for MWC Unit Nos. 1 and 2 were based on the maximum annual steam production rate achieved historically by each unit during the last 9 years: $509,294 \times 10^3$ lb/yr steam for Unit No. 1 and $508,062 \times 10^3$ lb/yr steam for Unit No. 2 (see Appendix A, Tables A-11 and A-12). These are the maximum rates that the units have demonstrated can be attained under current operating conditions and permit restrictions (i.e., prior to the requested change). The natural gas usage reflective of the heat input due to auxiliary fuels accompanying each of these maximum rates was also used: 1.87×10^6 cf for Unit No. 1 and 0.48×10^6 cf for Unit No. 2 (see Appendix A, Tables A-11 and A-12).

The emission factors for PM/PM₁₀/PM_{2.5}, VOC, Pb, Hg, HCl, SAM, F, and D/F were based on the highest stack test emission rate for stack tests conducted after the 2005 operational change, i.e., 2005 to 2008 test data (i.e., same as for the projected actual calculations), representative of current conditions. Emission factors for SO₂, NO_x, and CO were based on the maximum CEMS emission rate for each individual unit after the 2005 operational change (see Table 4-3 and Appendix A, Table A-10). The emission factors to calculate the post-change actual emissions from natural gas burning were the same emission factors used to calculate the baseline and projected actual emissions.

Post-change actual annual emissions without the proposed project, for MWC Unit Nos. 1 and 2, are shown in Table 4-3. These reflect the emissions the units are capable of accommodating prior to the requested change to re-rate the units.

4.4 Demand Growth Emissions

The difference between the baseline emissions calculated in Section 4.1 and the post-change actual emissions without the proposed project, calculated in Section 4.3, is termed "demand growth emissions." The demand growth emissions are shown in Table 4-4. For several pollutants, the post-change actual emissions without the proposed project are less than the baseline actual emissions. This is due to the requirement to meet the Subpart BBBB emission limits beginning in 2006, which reduced emissions starting in 2006. Baseline emissions for all pollutants except fluorides were based on the 2002 to 2003 time period, when emissions were higher. For pollutants where the baseline emissions are higher than the post-change actual emissions without the proposed project, the demand growth emissions are set to zero (i.e., demand growth cannot be a negative number).

4.5 Projected Actual Emissions (Final)

The projected actual emissions (initial) can be adjusted downward by the emissions due to demand growth. This is termed the "demand growth exclusion." The resulting emissions are the projected actual emissions (final). These emissions are shown in Table 4-5. These are the emissions that are compared to the baseline actual emissions to determine PSD applicability.

4.6 Effects on Other Emissions Units

The only regulated emissions units at the BCWTE are MWC Unit Nos. 1 and 2. The lime and carbon silos are insignificant units.

4.7 PSD Review

The BCWTE facility is considered to be an existing major stationary facility because potential emissions of at least one PSD-regulated pollutant exceed 100 TPY (for example, potential NO_x emissions currently exceed 100 TPY). Therefore, PSD review is required for any pollutant for which the net increase in emissions due to the modification is greater than the PSD significant emissions rates.

The net increase in emissions due to the proposed project at the BCWTE facility are summarized in Table 4-5. For MWC Unit Nos. 1 and 2, the baseline actual emissions and projected actual emissions (initial) are based on information from Tables 4-1 and 4-2, respectively. The demand growth excluded emissions are based on information from Table 4-4. The projected actual emissions (final) are obtained by adjusting the projected actual emissions (initial) downward by the demand growth exclusion. The comparison of projected actual emissions (final) to baseline actual emissions represents the net increase in emissions due to the project. These emissions are shown at the bottom of Table 4-5.

As shown in Table 4-5, the increase in emissions due to the project does not exceed the PSD significant emission rate for any pollutant. Therefore, PSD review does not apply to the proposed project.

TABLES

TABLE 3-1
PSD SIGNIFICANT EMISSION RATES

Pollutant	Significant Emission Rate (TPY)
Sulfur Dioxide	40
Particulate Matter [PM(TSP)]	25
Particulate Matter (PM ₁₀)	15
Particulate Matter (PM _{2.5})	10
Nitrogen Dioxide	40
Carbon Monoxide	100
Volatile Organic Compounds (Ozone)	40
Lead	0.6
Sulfuric Acid Mist	7
Total Fluorides	3
Total Reduced Sulfur	10
Reduced Sulfur Compounds	10
Hydrogen Sulfide	10
Mercury	0.1
MWC Organics (Dioxin/Furan)	3.5×10^{-6}
MWC Metals (as PM)	15
MWC Acid Gases (SO ₂ + HCl)	40
MSW Landfill Gases (as NMOC)	50

Note: Ambient monitoring requirements for any pollutant may be exempted if the impact of the increase in emissions is less than *de minimis* monitoring concentrations.

MWC = Municipal waste combustor.

MSW = Municipal solid waste.

Sources: 40 CFR 52.21.

Rule 62-212.400, F.A.C.

Checked by: DB

Reviewed by: DB

TABLE 4-1
BASELINE ACTUAL EMISSIONS
BAY COUNTY, PANAMA CITY

Source Description	Year 1			Year 2			Average (TPY)
	Activity Factor	Emission Factor	(TPY)	Activity Factor	Emission Factor	(TPY)	
Sulfur Dioxide - SO₂							
2002							
MWC Unit 001	509,294 10 ³ lb/yr Steam	0.130 lbs/10 ⁶ lb Steam	33.15	504,740 10 ³ lb/yr Steam	0.130 lbs/10 ⁶ lb Steam	32.85	33.00
	1.87 10 ⁶ CF Natural Gas	0.60 lb/10 ⁶ scf	5.6E-04	1.66 10 ⁶ CF Natural Gas	0.60 lb/10 ⁶ scf	5.0E-04	5.3E-04
MWC Unit 002	498,812 10 ³ lb/yr Steam	0.151 lbs/10 ⁶ lb Steam	37.61	480,553 10 ³ lb/yr Steam	0.151 lbs/10 ⁶ lb Steam	36.24	36.93
	1.83 10 ⁶ CF Natural Gas	0.60 lb/10 ⁶ scf	5.5E-04	1.65 10 ⁶ CF Natural Gas	0.60 lb/10 ⁶ scf	5.0E-04	5.2E-04
Total:			70.76			69.09	69.93
2003							
Nitrogen Oxides - NO_x							
2002							
MWC Unit 001	509,294 10 ³ lb/yr Steam	0.308 lbs/10 ⁶ lb Steam	78.35	504,740 10 ³ lb/yr Steam	0.308 lbs/10 ⁶ lb Steam	77.65	78.00
	1.87 10 ⁶ CF Natural Gas	100 lb/10 ⁶ scf	0.094	1.66 10 ⁶ CF Natural Gas	100 lb/10 ⁶ scf	0.083	0.088
MWC Unit 002	498,812 10 ³ lb/yr Steam	0.349 lbs/10 ⁶ lb Steam	87.08	480,553 10 ³ lb/yr Steam	0.349 lbs/10 ⁶ lb Steam	83.90	85.49
	1.83 10 ⁶ CF Natural Gas	100 lb/10 ⁶ scf	0.092	1.65 10 ⁶ CF Natural Gas	100 lb/10 ⁶ scf	0.083	0.087
Total:			165.62			161.71	163.67
2003							
Carbon Monoxide - CO							
2002							
MWC Unit 001	509,294 10 ³ lb/yr Steam	0.300 lbs/10 ⁶ lb Steam	76.45	504,740 10 ³ lb/yr Steam	0.300 lbs/10 ⁶ lb Steam	75.77	76.11
	1.87 10 ⁶ CF Natural Gas	84 lb/10 ⁶ scf	0.079	1.66 10 ⁶ CF Natural Gas	84 lb/10 ⁶ scf	0.070	0.074
MWC Unit 002	498,812 10 ³ lb/yr Steam	0.380 lbs/10 ⁶ lb Steam	94.68	480,553 10 ³ lb/yr Steam	0.380 lbs/10 ⁶ lb Steam	91.22	92.95
	1.83 10 ⁶ CF Natural Gas	84 lb/10 ⁶ scf	0.077	1.65 10 ⁶ CF Natural Gas	84 lb/10 ⁶ scf	0.069	0.073
Total:			171.29			167.12	169.20
2003							
Particulate Matter Tot - PM							
2002							
MWC Unit 001	509,294 10 ³ lb/yr Steam	0.0298 lbs/10 ⁶ lb Steam	7.60	504,740 10 ³ lb/yr Steam	0.0298 lbs/10 ⁶ lb Steam	7.53	7.56
	1.87 10 ⁶ CF Natural Gas	7.6 lb/10 ⁶ scf	0.0071	1.66 10 ⁶ CF Natural Gas	7.6 lb/10 ⁶ scf	0.0063	0.00671
MWC Unit 002	498,812 10 ³ lb/yr Steam	0.0378 lbs/10 ⁶ lb Steam	9.44	480,553 10 ³ lb/yr Steam	0.0378 lbs/10 ⁶ lb Steam	9.09	9.26
	1.83 10 ⁶ CF Natural Gas	7.6 lb/10 ⁶ scf	0.0070	1.65 10 ⁶ CF Natural Gas	7.6 lb/10 ⁶ scf	0.0063	0.00661
Total:			17.05			16.63	16.84
2003							
Particulate Matter - PM₁₀							
2002							
MWC Unit 001	509,294 10 ³ lb/yr Steam	0.0161 lbs/10 ⁶ lb Steam	4.10	504,740 10 ³ lb/yr Steam	0.0161 lbs/10 ⁶ lb Steam	4.07	4.08
	1.87 10 ⁶ CF Natural Gas	7.6 lb/10 ⁶ scf	0.0071	1.66 10 ⁶ CF Natural Gas	7.6 lb/10 ⁶ scf	0.0063	0.00671
MWC Unit 002	498,812 10 ³ lb/yr Steam	0.0204 lbs/10 ⁶ lb Steam	5.10	480,553 10 ³ lb/yr Steam	0.0204 lbs/10 ⁶ lb Steam	4.91	5.00
	1.83 10 ⁶ CF Natural Gas	7.6 lb/10 ⁶ scf	0.0070	1.65 10 ⁶ CF Natural Gas	7.6 lb/10 ⁶ scf	0.0063	0.00661
Total:			9.21			8.99	9.10
2003							
Particulate Matter - PM_{2.5}							
2002							
MWC Unit 001	509,294 10 ³ lb/yr Steam	0.0116 lbs/10 ⁶ lb Steam	2.96	504,740 10 ³ lb/yr Steam	0.0116 lbs/10 ⁶ lb Steam	2.94	2.95
	1.87 10 ⁶ CF Natural Gas	7.6 lb/10 ⁶ scf	0.0071	1.66 10 ⁶ CF Natural Gas	7.6 lb/10 ⁶ scf	0.0063	0.00671
MWC Unit 002	498,812 10 ³ lb/yr Steam	0.0148 lbs/10 ⁶ lb Steam	3.68	480,553 10 ³ lb/yr Steam	0.0148 lbs/10 ⁶ lb Steam	3.55	3.61
	1.83 10 ⁶ CF Natural Gas	7.6 lb/10 ⁶ scf	0.0070	1.65 10 ⁶ CF Natural Gas	7.6 lb/10 ⁶ scf	0.0063	0.00661
Total:			6.66			6.49	6.58
2003							
Volatile Org Compd - VOC							
2002							
MWC Unit 001	509,294 10 ³ lb/yr Steam	0.0190 lbs/10 ⁶ lb Steam	4.84	504,740 10 ³ lb/yr Steam	0.0190 lbs/10 ⁶ lb Steam	4.80	4.82
	1.87 10 ⁶ CF Natural Gas	5.5 lb/10 ⁶ scf	0.0051	1.66 10 ⁶ CF Natural Gas	5.5 lb/10 ⁶ scf	0.0046	0.00485
MWC Unit 002	498,812 10 ³ lb/yr Steam	0.0217 lbs/10 ⁶ lb Steam	5.41	480,553 10 ³ lb/yr Steam	0.0217 lbs/10 ⁶ lb Steam	5.21	5.31
	1.83 10 ⁶ CF Natural Gas	5.5 lb/10 ⁶ scf	0.0050	1.65 10 ⁶ CF Natural Gas	5.5 lb/10 ⁶ scf	0.0045	0.00479
Total:			10.26			10.02	10.14
2003							
Sulfuric Acid Mist - SAM							
2002							
MWC Unit 001	509,294 10 ³ lb/yr Steam	0.0058 lbs/10 ⁶ lb Steam	1.47	504,740 10 ³ lb/yr Steam	0.0058 lbs/10 ⁶ lb Steam	1.46	1.47
	1.87 10 ⁶ CF Natural Gas	0.027 lb/10 ⁶ scf	2.5E-05	1.66 10 ⁶ CF Natural Gas	0.027 lb/10 ⁶ scf	2.2E-05	2.4E-05
MWC Unit 002	498,812 10 ³ lb/yr Steam	0.0067 lbs/10 ⁶ lb Steam	1.67	480,553 10 ³ lb/yr Steam	0.0067 lbs/10 ⁶ lb Steam	1.61	1.64
	1.83 10 ⁶ CF Natural Gas	0.027 lb/10 ⁶ scf	2.4E-05	1.65 10 ⁶ CF Natural Gas	0.027 lb/10 ⁶ scf	2.2E-05	2.3E-05
Total:			3.15			3.07	3.11
2003							
Lead - Pb							
2002							
MWC Unit 001	509,294 10 ³ lb/yr Steam	6.1E-04 lbs/10 ⁶ lb Steam	0.15	504,740 10 ³ lb/yr Steam	6.1E-04 lbs/10 ⁶ lb Steam	0.15	0.15
	1.87 10 ⁶ CF Natural Gas	5.0E-04 lb/10 ⁶ scf	4.7E-07	1.66 10 ⁶ CF Natural Gas	5.0E-04 lb/10 ⁶ scf	4.2E-07	4.4E-07
MWC Unit 002	498,812 10 ³ lb/yr Steam	6.7E-04 lbs/10 ⁶ lb Steam	0.17	480,553 10 ³ lb/yr Steam	6.7E-04 lbs/10 ⁶ lb Steam	0.16	0.16
	1.83 10 ⁶ CF Natural Gas	5.0E-04 lb/10 ⁶ scf	4.6E-07	1.65 10 ⁶ CF Natural Gas	5.0E-04 lb/10 ⁶ scf	4.1E-07	4.4E-07
Total:			0.321			0.314	0.317
2003							
Mercury - Hg							
2002							
MWC Unit 001	509,294 10 ³ lb/yr Steam	7.8E-05 lbs/10 ⁶ lb Steam	0.020	504,740 10 ³ lb/yr Steam	7.8E-05 lbs/10 ⁶ lb Steam	0.020	0.020
	1.87 10 ⁶ CF Natural Gas	2.6E-04 lb/10 ⁶ scf	2.4E-07	1.66 10 ⁶ CF Natural Gas	2.6E-04 lb/10 ⁶ scf	2.2E-07	2.3E-07
MWC Unit 002	498,812 10 ³ lb/yr Steam	9.9E-05 lbs/10 ⁶ lb Steam	0.025	480,553 10 ³ lb/yr Steam	9.9E-05 lbs/10 ⁶ lb Steam	0.024	0.024
	1.83 10 ⁶ CF Natural Gas	2.6E-04 lb/10 ⁶ scf	2.4E-07	1.65 10 ⁶ CF Natural Gas	2.6E-04 lb/10 ⁶ scf	2.1E-07	2.3E-07
Total:			0.0446			0.0435	0.044
2003							
Fluorides - F							
2005							
MWC Unit 001	447,210 10 ³ lb/yr Steam	2.2E-04 lbs/10 ⁶ lb Steam	0.049	459,117 10 ³ lb/yr Steam	2.2E-04 lbs/10 ⁶ lb Steam	0.050	0.049
	2.50 10 ⁶ CF Natural Gas	-- lb/10 ⁶ scf	--	7.00 10 ⁶ CF Natural Gas	-- lb/10 ⁶ scf	--	--
MWC Unit 002	439,935 10 ³ lb/yr Steam	2.2E-04 lbs/10 ⁶ lb Steam	0.048	455,963 10 ³ lb/yr Steam	2.2E-04 lbs/10 ⁶ lb Steam	0.050	0.049
	2.50 10 ⁶ CF Natural Gas	-- lb/10 ⁶ scf	--	7.00 10 ⁶ CF Natural Gas	-- lb/10 ⁶ scf	--	--
Total:			0.0970			0.100	0.098
2006							
Hydrogen Chloride - HCl							
2002							
MWC Unit 001	509,294 10 ³ lb/yr Steam	0.072 lbs/10 ⁶ lb Steam	18.367	504,740 10 ³ lb/yr Steam	0.072 lbs/10 ⁶ lb Steam	18.203	18.28
	1.87 10 ⁶ CF Natural Gas	-- lb/10 ⁶ scf	--	1.66 10 ⁶ CF Natural Gas	-- lb/10 ⁶ scf	--	--
MWC Unit 002	498,812 10 ³ lb/yr Steam	0.078 lbs/10 ⁶ lb Steam	19.391	480,553 10 ³ lb/yr Steam	0.078 lbs/10 ⁶ lb Steam	18.681	19.04
	1.83 10 ⁶ CF Natural Gas	-- lb/10 ⁶ scf	--	1.65 10 ⁶ CF Natural Gas	-- lb/10 ⁶ scf	--	--
Total:			37.76			36.88	37.32
2003							
MWC - Organics (D/F)							
2002							
MWC Unit 001	509,294 10 ³ lb/yr Steam	4.2E-08 lbs/10 ⁶ lb Steam	1.1E-05	504,740 10 ³ lb/yr Steam	4.2E-08 lbs/10 ⁶ lb Steam	1.0E-05	1.1E-05
	1.87 10 ⁶ CF Natural Gas	-- lb/10 ⁶ scf	--	1.66 10 ⁶ CF Natural Gas	-- lb/10 ⁶ scf	--	--
MWC Unit 002	498,812 10 ³ lb/yr Steam	4.7E-08 lbs/10 ⁶ lb Steam	1.2E-05	480,553 10 ³ lb/yr Steam	4.7E-08 lbs/10 ⁶ lb Steam	1.1E-05	1.2E-05
	1.83 10 ⁶ CF Natural Gas	-- lb/10 ⁶ scf	--	1.65 10 ⁶ CF Natural Gas	-- lb/10 ⁶ scf	--	--
Total:			2.2E-05			2.2E-05	2.21E-05
2003							

Footnotes:
Based on Tables A-1, A-2, and A-3.

Checked by: DB
Reviewed by: DB

**TABLE 4-2
PROJECTED ACTUAL EMISSIONS (INITIAL)
BAY COUNTY, PANAMA CITY**

Pollutant	Activity Factor	Emission Factor ^a	Ref.	Annual Emissions (TPY)
Sulfur Dioxide - SO₂				
Municipal Waste Combustion Unit 001	565,896 x10 ³ lbs Steam	0.0181 lbs/10 ³ lb Steam	1	5.11
	22.24 x10 ⁶ CF Natural Gas	0.60 lb/10 ⁶ scf	2	0.0067
Municipal Waste Combustion Unit 002	565,896 x10 ³ lbs Steam	0.0284 lbs/10 ³ lb Steam	1	8.03
	22.240 x10 ⁶ CF Natural Gas	0.60 lb/10 ⁶ scf	2	0.0067
			Total:	13.16
Nitrogen Oxides - NO_x				
Municipal Waste Combustion Unit 001	565,896 x10 ³ lbs Steam	0.312 lbs/10 ³ lb Steam	1	88.38
	22.24 x10 ⁶ CF Natural Gas	100 lb/10 ⁶ scf	3	1.112
Municipal Waste Combustion Unit 002	565,896 x10 ³ lbs Steam	0.408 lbs/10 ³ lb Steam	1	115.44
	22.24 x10 ⁶ CF Natural Gas	100 lb/10 ⁶ scf	3	1.112
			Total:	206.04
Carbon Monoxide - CO				
Municipal Waste Combustion Unit 001	565,896 x10 ³ lbs Steam	0.239 lbs/10 ³ lb Steam	1	67.76
	22.24 x10 ⁶ CF Natural Gas	84 lb/10 ⁶ scf	3	0.934
Municipal Waste Combustion Unit 002	565,896 x10 ³ lbs Steam	0.380 lbs/10 ³ lb Steam	1	107.42
	22.24 x10 ⁶ CF Natural Gas	84 lb/10 ⁶ scf	3	0.934
			Total:	177.04
Particulate Matter Total - PM				
Municipal Waste Combustion Unit 001	565,896 x10 ³ lbs Steam	0.0401 lbs/10 ³ lb Steam	4	11.35
	22.24 x10 ⁶ CF Natural Gas	7.6 lb/10 ⁶ scf	2	0.0845
Municipal Waste Combustion Unit 002	565,896 x10 ³ lbs Steam	0.0306 lbs/10 ³ lb Steam	4	8.66
	22.24 x10 ⁶ CF Natural Gas	7.6 lb/10 ⁶ scf	2	0.0845
			Total:	20.17
Particulate Matter - PM₁₀				
Municipal Waste Combustion Unit 001	565,896 x10 ³ lbs Steam	0.0217 lbs/10 ³ lb Steam	5	6.13
	22.24 x10 ⁶ CF Natural Gas	7.6 lb/10 ⁶ scf	2	0.0845
Municipal Waste Combustion Unit 002	565,896 x10 ³ lbs Steam	0.0165 lbs/10 ³ lb Steam	5	4.68
	22.24 x10 ⁶ CF Natural Gas	7.6 lb/10 ⁶ scf	2	0.0845
			Total:	10.97
Particulate Matter - PM_{2.5}				
Municipal Waste Combustion Unit 001	565,896 x10 ³ lbs Steam	0.0156 lbs/10 ³ lb Steam	5	4.43
	22.24 x10 ⁶ CF Natural Gas	7.6 lb/10 ⁶ scf	2	0.0845
Municipal Waste Combustion Unit 002	565,896 x10 ³ lbs Steam	0.0119 lbs/10 ³ lb Steam	5	3.38
	22.24 x10 ⁶ CF Natural Gas	7.6 lb/10 ⁶ scf	2	0.0845
			Total:	7.97
Volatile Organic Compounds - VOC				
Municipal Waste Combustion Unit 001	565,896 x10 ³ lbs Steam	0.0205 lbs/10 ³ lb Steam	4	5.80
	22.24 x10 ⁶ CF Natural Gas	5.5 lb/10 ⁶ scf	2	0.0612
Municipal Waste Combustion Unit 002	565,896 x10 ³ lbs Steam	0.00825 lbs/10 ³ lb Steam	4	2.33
	22.24 x10 ⁶ CF Natural Gas	5.5 lb/10 ⁶ scf	2	0.0612
			Total:	8.26
Sulfuric Acid Mist - SAM				
Municipal Waste Combustion Unit 001	565,896 x10 ³ lbs Steam	0.00080 lbs/10 ³ lb Steam	6	0.227
	22.24 x10 ⁶ CF Natural Gas	0.02670 lb/10 ⁶ scf	6	3.0E-04
Municipal Waste Combustion Unit 002	565,896 x10 ³ lbs Steam	0.00126 lbs/10 ³ lb Steam	6	0.358
	22.24 x10 ⁶ CF Natural Gas	0.02670 lb/10 ⁶ scf	6	3.0E-04
			Total:	0.585
Lead - Pb				
Municipal Waste Combustion Unit 001	565,896 x10 ³ lbs Steam	7.16E-05 lbs/10 ³ lb Steam	4	0.020
	22.24 x10 ⁶ CF Natural Gas	5.0E-04 lb/10 ⁶ scf	2	5.6E-06
Municipal Waste Combustion Unit 002	565,896 x10 ³ lbs Steam	1.53E-05 lbs/10 ³ lb Steam	4	0.0043
	22.24 x10 ⁶ CF Natural Gas	5.0E-04 lb/10 ⁶ scf	2	5.6E-06
			Total:	0.025
Mercury - Hg				
Municipal Waste Combustion Unit 001	565,896 x10 ³ lbs Steam	2.17E-05 lbs/10 ³ lb Steam	4	0.0061
	22.24 x10 ⁶ CF Natural Gas	2.6E-04 lb/10 ⁶ scf	7	2.9E-06
Municipal Waste Combustion Unit 002	565,896 x10 ³ lbs Steam	1.55E-05 lbs/10 ³ lb Steam	4	0.0044
	22.24 x10 ⁶ CF Natural Gas	2.6E-04 lb/10 ⁶ scf	7	2.9E-06
			Total:	0.0105
Fluorides - F				
Municipal Waste Combustion Unit 001	565,896 x10 ³ lbs Steam	2.18E-04 lbs/10 ³ lb Steam	4	0.062
	22.24 x10 ⁶ CF Natural Gas	-- lb/10 ⁶ scf	--	--
Municipal Waste Combustion Unit 002	565,896 x10 ³ lbs Steam	2.19E-04 lbs/10 ³ lb Steam	4	0.062
	22.24 x10 ⁶ CF Natural Gas	-- lb/10 ⁶ scf	--	--
			Total:	0.12
Hydrogen Chloride - HCl				
Municipal Waste Combustion Unit 001	565,896 x10 ³ lbs Steam	0.0530 lbs/10 ³ lb Steam	4	15.00
	22.24 x10 ⁶ CF Natural Gas	-- lb/10 ⁶ scf	--	--
Municipal Waste Combustion Unit 002	565,896 x10 ³ lbs Steam	0.0274 lbs/10 ³ lb Steam	4	7.75
	22.24 x10 ⁶ CF Natural Gas	-- lb/10 ⁶ scf	--	--
			Total:	22.75
MWC - Organics (D/F)				
Municipal Waste Combustion Unit 001	565,896 x10 ³ lbs Steam	4.73E-08 lbs/10 ³ lb Steam	4	1.34E-05
	22.24 x10 ⁶ CF Natural Gas	-- lb/10 ⁶ scf	--	--
Municipal Waste Combustion Unit 002	565,896 x10 ³ lbs Steam	3.61E-08 lbs/10 ³ lb Steam	4	1.02E-05
	22.24 x10 ⁶ CF Natural Gas	-- lb/10 ⁶ scf	--	--
			Total:	2.36E-05

Notes:

^a Activity factor based on the maximum requested hourly steam rate (68,000 lb/hr) times 95% availability factor.
Natural gas burned in each MWC unit based on maximum during baseline period (see Tables A-11 and A-12).

References:

1. Based on highest emission rate for each unit after 2005 operational change. Emission rate based on CEMs data.
2. Based on AP-42, Table 1.4-2.
3. Based on AP-42, Table 1.4-1.
4. Based on highest annual stack test emission rate for each unit after 2005 operational change.
5. Based on EPA's PM Calculator where 54% of PM is PM₁₀ and 39% of PM is PM_{2.5}.
6. Based on similar method used for fuel oil, where the ratio of SO₂ emissions to SO₂ emissions (5.7/157) is multiplied by the ratio of the molecular weights of H₂SO₄ and SO₂ (98/80), resulting in approximately 4.45% of SO₂ emissions becoming SAM.
7. Based on AP-42, Table 1.4-4.

Checked by: DB
Reviewed by: DB

**TABLE 4-3
POST-CHANGE ACTUAL EMISSIONS (WITHOUT PROPOSED PROJECT)
BAY COUNTY, PANAMA CITY**

Pollutant	Emission Factor ^a	Activity Factor	Ref.	Annual Emissions (TPY)
Sulfur Dioxide - SO₂				
Municipal Waste Combustion Unit 001	509,294 x10 ³ lbs Steam	0.0181 lbs/10 ³ lb Steam	1	4.60
	1.87 x10 ⁶ CF Natural Gas	0.60 lb/10 ⁶ scf	2	5.6E-04
Municipal Waste Combustion Unit 002	508,062 x10 ³ lbs Steam	0.0284 lbs/10 ³ lb Steam	1	7.21
	0.48 x10 ⁶ CF Natural Gas	0.60 lb/10 ⁶ scf	2	1.4E-04
			Total:	11.81
Nitrogen Oxides - NO_x				
Municipal Waste Combustion Unit 001	509,294 x10 ³ lbs Steam	0.312 lbs/10 ³ lb Steam	1	79.54
	1.87 x10 ⁶ CF Natural Gas	100 lb/10 ⁶ scf	3	0.094
Municipal Waste Combustion Unit 002	508,062 x10 ³ lbs Steam	0.408 lbs/10 ³ lb Steam	1	103.64
	0.48 x10 ⁶ CF Natural Gas	100 lb/10 ⁶ scf	3	0.024
			Total:	183.30
Carbon Monoxide - CO				
Municipal Waste Combustion Unit 001	509,294 x10 ³ lbs Steam	0.239 lbs/10 ³ lb Steam	1	60.98
	1.87 x10 ⁶ CF Natural Gas	84 lb/10 ⁶ scf	3	0.079
Municipal Waste Combustion Unit 002	508,062 x10 ³ lbs Steam	0.380 lbs/10 ³ lb Steam	1	96.44
	0.48 x10 ⁶ CF Natural Gas	84 lb/10 ⁶ scf	3	0.020
			Total:	157.51
Particulate Matter Total - PM				
Municipal Waste Combustion Unit 001	509,294 x10 ³ lbs Steam	0.0401 lbs/10 ³ lb Steam	4	10.21
	1.87 x10 ⁶ CF Natural Gas	7.6 lb/10 ⁶ scf	2	0.0071
Municipal Waste Combustion Unit 002	508,062 Hours of Operation	0.0306 lbs/10 ³ lb Steam	4	7.78
	0.48 x10 ⁶ CF Natural Gas	7.6 lb/10 ⁶ scf	2	0.0018
			Total:	18.00
Particulate Matter - PM₁₀				
Municipal Waste Combustion Unit 001	509,294 x10 ³ lbs Steam	0.0216 lbs/10 ³ lb Steam	5	5.51
	1.87 x10 ⁶ CF Natural Gas	7.6 lb/10 ⁶ scf	2	0.0071
Municipal Waste Combustion Unit 002	508,062 Hours of Operation	0.0165 lbs/10 ³ lb Steam	5	4.20
	0.48 x10 ⁶ CF Natural Gas	7.6 lb/10 ⁶ scf	2	0.0018
			Total:	9.72
Particulate Matter - PM_{2.5}				
Municipal Waste Combustion Unit 001	509,294 x10 ³ lbs Steam	0.0156 lbs/10 ³ lb Steam	5	3.98
	1.87 x10 ⁶ CF Natural Gas	7.6 lb/10 ⁶ scf	2	0.0071
Municipal Waste Combustion Unit 002	508,062 Hours of Operation	0.0119 lbs/10 ³ lb Steam	5	3.04
	0.48 x10 ⁶ CF Natural Gas	7.6 lb/10 ⁶ scf	2	0.0018
			Total:	7.03
Volatile Organic Compounds - VOC				
Municipal Waste Combustion Unit 001	509,294 x10 ³ lbs Steam	0.0205 lbs/10 ³ lb Steam	4	5.209
	1.87 x10 ⁶ CF Natural Gas	5.5 lb/10 ⁶ scf	2	0.0051
Municipal Waste Combustion Unit 002	508,062 Hours of Operation	0.00825 lbs/10 ³ lb Steam	4	2.10
	0.48 x10 ⁶ CF Natural Gas	5.5 lb/10 ⁶ scf	2	0.0013
			Total:	7.31
Sulfuric Acid Mist - SAM				
Municipal Waste Combustion Unit 001	509,294 x10 ³ lbs Steam	0.00080 lbs/10 ³ lb Steam	6	0.204
	1.87 x10 ⁶ CF Natural Gas	0.0267 lb/10 ⁶ scf	6	2.5E-05
Municipal Waste Combustion Unit 002	508,062 Hours of Operation	0.00126 lbs/10 ³ lb Steam	6	0.321
	0.48 x10 ⁶ CF Natural Gas	0.0267 lb/10 ⁶ scf	6	6.4E-06
			Total:	0.525
Lead - Pb				
Municipal Waste Combustion Unit 001	509,294 x10 ³ lbs Steam	7.16E-05 lbs/10 ³ lb Steam	4	0.0182
	1.87 x10 ⁶ CF Natural Gas	5.0E-04 lb/10 ⁶ scf	2	4.7E-07
Municipal Waste Combustion Unit 002	508,062 Hours of Operation	1.53E-05 lbs/10 ³ lb Steam	4	0.0039
	0.48 x10 ⁶ CF Natural Gas	5.0E-04 lb/10 ⁶ scf	2	1.2E-07
			Total:	0.022
Mercury - Hg				
Municipal Waste Combustion Unit 001	509,294 x10 ³ lbs Steam	2.17E-05 lbs/10 ³ lb Steam	4	0.0055
	1.87 x10 ⁶ CF Natural Gas	2.6E-04 lb/10 ⁶ scf	6	2.4E-07
Municipal Waste Combustion Unit 002	508,062 Hours of Operation	1.55E-05 lbs/10 ³ lb Steam	4	0.0039
	0.48 x10 ⁶ CF Natural Gas	2.6E-04 lb/10 ⁶ scf	6	6.2E-08
			Total:	0.0094
Fluorides - F				
Municipal Waste Combustion Unit 001	509,294 x10 ³ lbs Steam	2.18E-04 lbs/10 ³ lb Steam	4	0.056
	1.87 x10 ⁶ CF Natural Gas	-- lb/10 ⁶ scf	--	--
Municipal Waste Combustion Unit 002	508,062 Hours of Operation	2.19E-04 lbs/10 ³ lb Steam	4	0.056
	0.48 x10 ⁶ CF Natural Gas	-- lb/10 ⁶ scf	--	--
			Total:	0.111
Hydrogen Chloride - HCl				
Municipal Waste Combustion Unit 001	509,294 x10 ³ lbs Steam	0.0530 lbs/10 ³ lb Steam	4	13.50
	1.87 x10 ⁶ CF Natural Gas	-- lb/10 ⁶ scf	--	--
Municipal Waste Combustion Unit 002	508,062 x10 ³ lbs Steam	0.0274 lbs/10 ³ lb Steam	4	6.96
	0.48 x10 ⁶ CF Natural Gas	-- lb/10 ⁶ scf	--	--
			Total:	20.46
MWC - Organics (D/F)				
Municipal Waste Combustion Unit 001	509,294 x10 ³ lbs Steam	4.73E-08 lbs/10 ³ lb Steam	4	1.20E-05
	1.87 x10 ⁶ CF Natural Gas	-- lb/10 ⁶ scf	--	--
Municipal Waste Combustion Unit 002	508,062 x10 ³ lbs Steam	3.61E-08 lbs/10 ³ lb Steam	4	9.17E-06
	0.48 x10 ⁶ CF Natural Gas	-- lb/10 ⁶ scf	--	--
			Total:	2.12E-05

Notes:

^a Activity factor based on the maximum steam production rate (lb/yr) achieved during baseline period (2000-2008) for each unit, and accompanying auxiliary fuel use (see Tables A-11 and A-12).

References:

1. Based on highest emission rate for each unit after 2005 operational change. Emission rate based on CEMs data.
2. Based on AP-42, Table 1.4-2.
3. Based on AP-42, Table 1.4-1.
4. Based on highest annual stack test emission rate for each unit after 2005 operational change.
5. Based on EPA's PM Calculator where 54% of PM is PM₁₀ and 39% of PM is PM_{2.5}.
6. Based on similar method used for fuel oil, where the ratio of SO₃ emissions to SO₂ emissions (5.7/157) is multiplied by the ratio of the molecular weights of H₂SO₄ and SO₃ (98/80), resulting in approximately 4.45% of SO₂ emissions becoming SAM.
7. Based on AP-42, Table 1.4-4.

Checked by: DB
Reviewed by: DB

**TABLE 4-4
DEMAND GROWTH EMISSIONS CALCULATION
BAY COUNTY, PANAMA CITY**

Source Description	Pollutant Emission Rate (TPY)											MWC Acid Gases ^d (SO ₂ +HCl)	MWC Organics (Dioxins/Furans)	
	SO ₂	NO _x	CO	PM	PM ₁₀	PM _{2.5}	VOC	SAM	Lead	Mercury	Fluoride			HCl
Post-Change Actual Emissions (Without Project)^a														
Municipal Waste Combustion Unit 001	4.60	79.63	61.06	10.21	5.52	3.99	5.21	0.20	0.0182	0.0055	0.056	13.50	18.10	1.20E-05
Municipal Waste Combustion Unit 002	7.21	103.67	96.46	7.79	4.20	3.04	2.10	0.32	0.0039	0.0039	0.056	6.96	14.17	9.17E-06
Total- Post-Change Actual	11.81	183.30	157.51	18.00	9.72	7.0	7.31	0.53	0.022	0.0094	0.11	20.46	32.27	2.12E-05
Baseline Actual Emissions^b														
Municipal Waste Combustion Unit 001	33.00	78.00	76.11	7.56	4.08	2.95	4.82	1.47	0.1534	0.020	0.049	18.28	51.28	1.05E-05
Municipal Waste Combustion Unit 002	36.93	85.49	92.95	9.26	5.00	3.61	5.31	1.64	0.1640	0.024	0.049	19.04	55.96	1.16E-05
Total- Projected Actual	69.92	163.49	169.06	16.83	9.09	6.56	10.13	3.11	0.317	0.044	0.098	37.32	107.25	2.21E-05
Demand Growth Exclusion^c														
Municipal Waste Combustion Unit 001	0.0	1.63	0.0	2.65	1.43	1.0	0.39	0.0	0.0	0.0	0.0061	0.0	0.0	0.0
Municipal Waste Combustion Unit 002	0.0	18.18	3.51	0.0	0.0	0.0	0.0	0.0	0.0	0.0	0.0066	0.0	0.0	0.0
Total- Demand Growth	0.0	19.81	3.51	2.65	1.43	1.04	0.39	0.0	0.0	0.0	0.013	0.0	0.0	1.51E-06

Notes:

^a Based on maximum emissions the emissions unit could have accommodated during the baseline period, without the proposed project; see Table 4-3.

^b Based on annual emissions presented in Table 4-1.

^c Represents the additional emissions that the unit could have accommodated during the baseline period.

^d SO₂ plus HCl.

Checked by: DL
Reviewed by: RB

**TABLE 4-5
PSD APPLICABILITY ANALYSIS, RE-RATE PROJECT
BAY COUNTY, PANAMA CITY**

Source Description	EU ID	Pollutant Emission Rate (TPY)													
		SO ₂	NO _x	CO	PM	PM ₁₀ /MWC Metals	PM _{2.5}	VOC	SAM	Lead	Mercury	Fluoride	HCl	MWC Acid Gases (SO ₂ +HCl)	MWC Organics (Dioxins/Furans)
Projected Actual Emissions (Final) ^a															
- Municipal Waste Combustion Unit	001	5.11	87.86	68.69	8.78	4.78	3.47	5.47	0.23	0.020	0.0061	0.056	14.998	20.11	1.19E-05
- Municipal Waste Combustion Unit	002	8.04	98.38	104.84	8.74	4.76	3.46	2.40	0.36	0.0043	0.0044	0.055	7.749	15.79	1.02E-05
Total- Projected Actual		13.16	186.24	173.53	17.52	9.54	6.93	7.87	0.585	0.0246	0.0105	0.111	22.75	35.90	2.21E-05
Projected Actual Emissions (Initial) ^b															
- Municipal Waste Combustion Unit	001	5.11	89.49	68.69	11.43	6.21	4.51	5.86	0.228	0.0203	0.0061	0.062	15.00	20.11	1.34E-05
- Municipal Waste Combustion Unit	002	8.04	116.55	108.35	8.74	4.76	3.46	2.40	0.358	0.0043	0.0044	0.062	7.75	15.79	1.02E-05
Total- Projected Actual		13.16	206.04	177.04	20.17	10.97	7.97	8.26	0.585	0.0246	0.0105	0.124	22.75	35.90	2.36E-05
Demand Growth Exclusion ^c															
- Municipal Waste Combustion Unit	001	0.0	1.63	0.0	2.65	1.43	1.04	0.39	0.0	0.0	0.0	0.0061	0.00	0.0	1.51E-06
- Municipal Waste Combustion Unit	002	0.0	18.18	3.51	0.0	0.0	0.0	0.0	0.0	0.0	0.0	0.0066	0.00	0.0	0.0
Total- Demand Growth		0.0	19.81	3.51	2.65	1.43	1.04	0.39	0.0	0.0	0.0	0.013	0.00	0.0	1.51E-06
Baseline Actual Emissions ^d															
- Municipal Waste Combustion Unit	001	33.00	78.09	76.18	7.57	4.09	2.96	4.83	1.47	0.15	0.0198	0.049	18.28	18.28	1.05E-05
- Municipal Waste Combustion Unit	002	36.93	85.58	93.02	9.27	5.01	3.62	5.32	1.64	0.16	0.0242	0.049	19.04	19.04	1.16E-05
Total- Baseline Actual		69.93	163.67	169.20	16.84	9.10	6.58	10.14	3.11	0.32	0.044	0.098	37.32	37.32	2.21E-05
Increase Due to Project															
- Municipal Waste Combustion Unit	001	-27.88	9.77	-7.49	1.21	0.69	0.51	0.64	-1.24	-0.13	-0.01	0.01	-3.29	1.83	1.34E-06
- Municipal Waste Combustion Unit	002	-28.89	12.80	11.82	-0.53	-0.25	-0.16	-2.92	-1.28	-0.16	-0.02	0.01	-11.29	-3.25	-1.38E-06
Total- Increase Due to Project		-56.77	22.57	4.33	0.68	0.44	0.36	-2.28	-2.52	-0.29	-0.034	0.013	-14.57	-1.42	-3.74E-08
PSD SIGNIFICANT EMISSION RATE		40	40	100	25	15	NA	40	7	0.6	0.1	3	NA	40	3.5E-06
PSD REVIEW TRIGGERED?		No	No	No	No	No	No	No	No	No	No	No	No	No	No

^a "Final" projected emissions, subtracting out the portion of the emissions increase that could have been accommodated during the baseline period and is unrelated to the change (demand growth).

^b Unit's projected emissions following the proposed change. Refer to Table 4-3.

^c Refer to Table 4-4.

^d Refer to Table 4-1.

Checked by: DB
Reviewed by: DB

APPENDIX A

**BASELINE ACTUAL EMISSIONS CALCULATIONS
FOR MWC UNIT NOS. 1 AND 2**

**TABLE A-1
REVISED EMISSION FACTORS USED TO DETERMINE ACTUAL ANNUAL EMISSIONS, MWC UNIT NO. 1 (2000-2008)
BAY COUNTY, PANAMA CITY**

Source Description	Annual Operation (hr/yr)	Steam Production (10 ³ lb/yr)	Annual Fuel Usage	Units	Pollutant Emission Factors												
					SO ₂	NO _x	CO	PM	PM ₁₀	PM _{2.5}	VOC	SAM ^B	Lead	Mercury	Fluoride ^M	HCl ^N	Dioxins/Furans ^N
Municipal Waste Combustion Unit 001																	
2000 Actual Emission Factors	7,741	484,919	84,852 ton MSW	lbs/10 ⁶ lb Steam	0.130 ^A	0.308 ^A	0.300 ^A	0.0298 ^A	0.0161 ^L	0.0116 ^L	0.0190 ^A	0.00579	6.05E-04 ^A	7.83E-05 ^A	1.28E-04	0.072	4.2E-08
			0.06 x10 ⁶ CF Natural Gas	lb/10 ⁶ scf	0.60 ^G	100 ^H	84 ^H	7.60 ^G	7.60 ^G	7.60	5.50 ^G	0.0267	5.0E-04 ^G	2.6E-04 ^I	-	-	-
			3.00 x10 ³ gal Distillate Oil	lb/10 ³ gal	71 ^C	20.00 ^C	5.00 ^C	2.00 ^D	1.00 ^D	2.00	0.20 ^E	3.16	-	-	0.0373 ^K	-	-
			0.07 x10 ³ gal Propane	lb/10 ³ gal	1.50 ^F	13.00 ^F	7.5 ^F	0.70 ^F	0.70 ^F	0.70	1.00 ^F	0.067	-	-	-	-	-
2001 Actual Emission Factors	7,910	492,191	90,973 ton MSW	lbs/10 ⁶ lb Steam	0.130 ^A	0.308 ^A	0.300 ^A	0.0298 ^A	0.0161 ^L	0.0116 ^L	0.0190 ^A	0.00579	6.05E-04 ^A	7.83E-05 ^A	1.28E-04	0.072	4.2E-08
			0.09 x10 ⁶ CF Natural Gas	lb/10 ⁶ scf	0.60 ^G	100 ^H	84 ^H	7.60 ^G	7.60 ^G	7.60	5.50 ^G	0.0267	5.0E-04 ^G	2.6E-04 ^I	-	-	-
2002 Actual Emission Factors	8,211	509,294	93,107 ton MSW	lbs/10 ⁶ lb Steam	0.130 ^A	0.308 ^A	0.300 ^A	0.0298 ^A	0.0161 ^L	0.0116 ^L	0.0190 ^A	0.00579	6.05E-04 ^A	7.83E-05 ^A	1.28E-04	0.072	4.2E-08
			1.87 x10 ⁶ CF Natural Gas	lb/10 ⁶ scf	0.60 ^G	100 ^H	84 ^H	7.60 ^G	7.60 ^G	7.60	5.50 ^G	0.0267	5.0E-04 ^G	2.6E-04 ^I	-	-	-
2003 Actual Emission Factors	8,135	504,740	95,931 ton MSW	lbs/10 ⁶ lb Steam	0.130 ^A	0.308 ^A	0.300 ^A	0.0298 ^A	0.0161 ^L	0.0116 ^L	0.0190 ^A	0.00579	6.05E-04 ^A	7.83E-05 ^A	1.28E-04	0.072	4.2E-08
			1.66 x10 ⁶ CF Natural Gas	lb/10 ⁶ scf	0.60 ^G	100 ^H	84 ^H	7.60 ^G	7.60 ^G	7.60	5.50 ^G	0.0267	5.0E-04 ^G	2.6E-04 ^I	-	-	-
2004 Actual Emission Factors	7,758	479,689	94,093 ton MSW	lbs/10 ⁶ lb Steam	0.130 ^A	0.308 ^A	0.300 ^A	0.0298 ^A	0.0161 ^L	0.0116 ^L	0.0190 ^A	0.00579	6.05E-04 ^A	7.83E-05 ^A	1.28E-04	0.072	4.2E-08
			1.67 x10 ⁶ CF Natural Gas	lb/10 ⁶ scf	0.60 ^G	100 ^H	84 ^H	7.60 ^G	7.60 ^G	7.60	5.50 ^G	0.0267	5.0E-04 ^G	2.6E-04 ^I	-	-	-
2005 Actual Emission Factors	7,227	447,210	93,242 ton MSW	lbs/10 ⁶ lb Steam	0.138 ^A	0.308 ^A	0.300 ^A	0.0216 ^A	0.0117 ^L	0.0084 ^L	0.0107 ^A	0.00614	3.42E-05 ^A	1.01E-05 ^A	2.18E-04	0.023	3.1E-08
			2.50 x10 ⁶ CF Natural Gas	lb/10 ⁶ scf	0.60 ^G	100 ^H	84 ^H	7.60 ^G	7.60 ^G	7.60	5.50 ^G	0.0267	5.0E-04 ^G	2.6E-04 ^I	-	-	-
2006 Actual Emission Factors	7,406	459,117	89,505 ton MSW	lbs/10 ⁶ lb Steam	0.0149 ^J	0.262 ^J	0.239 ^J	0.0216 ^A	0.0117 ^L	0.0084 ^L	0.0107 ^A	6.6E-04	3.42E-05 ^A	1.01E-05 ^A	2.18E-04	0.023	3.1E-08
			7.00 x10 ⁶ CF Natural Gas	lb/10 ⁶ scf	0.60 ^G	100 ^H	84 ^H	7.60 ^G	7.60 ^G	7.60	5.50 ^G	0.0267	5.0E-04 ^G	2.6E-04 ^I	-	-	-
2007 Actual Emission Factors	6,909	415,180	77,780 ton MSW	lbs/10 ⁶ lb Steam	0.0168 ^J	0.312 ^J	0.222 ^J	0.0216 ^A	0.0117 ^L	0.0084 ^L	0.0107 ^A	7.5E-04	3.42E-05 ^A	1.01E-05 ^A	2.18E-04	0.023	3.1E-08
			9.85 x10 ⁶ CF Natural Gas	lb/10 ⁶ scf	0.60 ^G	100 ^H	84 ^H	7.60 ^G	7.60 ^G	7.60	5.50 ^G	0.0267	5.0E-04 ^G	2.6E-04 ^I	-	-	-
2008 Actual Emission Factors	5,416	293,217	46,891 ton MSW	lbs/10 ⁶ lb Steam	0.0181 ^J	0.223 ^J	0.204 ^J	0.0216 ^A	0.0117 ^L	0.0084 ^L	0.0107 ^A	8.0E-04	3.42E-05 ^A	1.01E-05 ^A	2.18E-04	0.023	3.1E-08
			22.24 x10 ⁶ CF Natural Gas	lb/10 ⁶ scf	0.60 ^G	100 ^H	84 ^H	7.60 ^G	7.60 ^G	7.60	5.50 ^G	0.0267	5.0E-04 ^G	2.6E-04 ^I	-	-	-

^A Based on 5-year average stack tests (see Table A-6).

^B Based on similar method used for fuel oil, where the ratio of SO₃ emissions to SO₂ emissions (5.7/157) is multiplied by the ratio of the molecular weights of H₂SO₄ and SO₃ (98/80), resulting in approximately 4.45% of SO₂ emissions becoming SAM.

^C Based on AP-42, Table 1.3-1. SO₂ is calculated with 142S where S is the sulfur content, 0.5-percent.

^D Based on AP-42, Table 1.3-6.

^E Based on AP-42, Table 1.3-3.

^F Based on AP-42, Table 1.5-1. SO₂ = 0.10S, where S is the sulfur content, 15 gr/cf.

^G Based on AP-42, Table 1.4-2.

^H Based on AP-42, Table 1.4-1.

^I Based on AP-42, Table 1.4-4.

^J Based on annual CEMS data. See Table A-10.

^K Based on AP-42, Table 1.3-11.

^L Based on EPA's PM Calculator where 54% of PM is PM₁₀ and 39% of PM is PM_{2.5}.

^M Based on the 1999 stack test of 0.0077 lb/hr for 2000 through 2004 and the 2005 stack test of 0.014 lb/hr for 2005 through 2008 divided by the steam production rate.

^N For MSW factor, refer to Table A-6.

Checked By: OB
Reviewed By: OH

**TABLE A-2
REVISED EMISSION FACTORS USED TO DETERMINE ACTUAL ANNUAL EMISSIONS, MWC UNIT NO. 2 (2000-2008)
BAY COUNTY, PANAMA CITY**

Source Description	Annual Operation (hr/yr)	Steam Production (10 ³ lb/yr)	Annual Fuel Usage	Units	Pollutant Emission Factors												
					SO ₂	NO _x	CO	PM	PM ₁₀	PM _{2.5}	VOC	SAM ^B	Lead	Mercury	Fluoride ^M	HCl ^N	Dioxins/Furans ^N
Municipal Waste Combustion Unit 002																	
2000 Actual Emission Factors	8,025	508,062	87,966 ton MSW	lbs/10 ⁶ lb Steam	0.151 ^A	0.349 ^A	0.380 ^A	0.0378 ^A	0.0204 ^L	0.0148 ^L	0.0217 ^A	0.00671	6.7E-04 ^A	9.9E-05 ^A	1.15E-04	0.0777	4.74E-08
			0.07 x10 ⁶ CF Natural Gas	lb/10 ⁶ scf	0.60 ^G	100 ^H	84 ^H	7.60 ^G	7.60 ^G	7.60 ^G	5.5 ^G	0.0267	5.0E-04 ^G	2.6E-04 ^I	--	--	--
			3.10 x10 ³ gal Distillate Oil	lb/10 ³ gal	71 ^C	20 ^C	5.00 ^C	2.00 ^D	1.00 ^D	2.00 ^D	0.20 ^E	3.16	--	--	0.0373	--	--
			0.07 x10 ³ gal Propane	lb/10 ³ gal	1.50 ^F	13.00 ^F	7.5 ^F	0.70 ^F	0.70 ^F	0.70 ^F	1.00 ^F	0.067	--	--	--	--	--
2001 Actual Emission Factors	7,812	482,414	89,846 ton MSW	lbs/10 ⁶ lb Steam	0.151 ^A	0.349 ^A	0.380 ^A	0.0378 ^A	0.0204 ^L	0.0148 ^L	0.0217 ^A	0.00671	6.7E-04 ^A	9.9E-05 ^A	1.15E-04	0.0777	4.74E-08
			0.08 x10 ⁶ CF Natural Gas	lb/10 ⁶ scf	0.60 ^G	100 ^H	84 ^H	7.60 ^G	7.60 ^G	7.60 ^G	5.5 ^G	0.0267	5.0E-04 ^G	2.6E-04 ^I	--	--	--
2002 Actual Emission Factors	8,026	498,812	91,227 ton MSW	lbs/10 ⁶ lb Steam	0.151 ^A	0.349 ^A	0.380 ^A	0.0378 ^A	0.0204 ^L	0.0148 ^L	0.0217 ^A	0.00671	6.7E-04 ^A	9.9E-05 ^A	1.15E-04	0.0777	4.74E-08
			1.83 x10 ⁶ CF Natural Gas	lb/10 ⁶ scf	0.60 ^G	100 ^H	84 ^H	7.60 ^G	7.60 ^G	7.60 ^G	5.5 ^G	0.0267	5.0E-04 ^G	2.6E-04 ^I	--	--	--
2003 Actual Emission Factors	7,948	480,553	95,242 ton MSW	lbs/10 ⁶ lb Steam	0.151 ^A	0.349 ^A	0.380 ^A	0.0378 ^A	0.0204 ^L	0.0148 ^L	0.0217 ^A	0.00671	6.7E-04 ^A	9.9E-05 ^A	1.15E-04	0.0777	4.74E-08
			1.65 x10 ⁶ CF Natural Gas	lb/10 ⁶ scf	0.60 ^G	100 ^H	84 ^H	7.60 ^G	7.60 ^G	7.60 ^G	5.5 ^G	0.0267	5.0E-04 ^G	2.6E-04 ^I	--	--	--
2004 Actual Emission Factors	7,521	460,883	91,129 ton MSW	lbs/10 ⁶ lb Steam	0.151 ^A	0.349 ^A	0.380 ^A	0.0378 ^A	0.0204 ^L	0.0148 ^L	0.0217 ^A	0.00671	6.7E-04 ^A	9.9E-05 ^A	1.15E-04	0.0777	4.74E-08
			1.62 x10 ⁶ CF Natural Gas	lb/10 ⁶ scf	0.60 ^G	100 ^H	84 ^H	7.60 ^G	7.60 ^G	7.60 ^G	5.5 ^G	0.0267	5.0E-04 ^G	2.6E-04 ^I	--	--	--
2005 Actual Emission Factors	7,147	439,935	92,499 ton MSW	lbs/10 ⁶ lb Steam	0.094 ^A	0.349 ^A	0.380 ^A	0.0138 ^A	0.00743 ^L	0.00536 ^L	0.00608 ^A	0.00420	7.9E-06 ^A	7.7E-06 ^A	2.19E-04	0.0148	2.3E-08
			2.50 x10 ⁶ CF Natural Gas	lb/10 ⁶ scf	0.60 ^G	100 ^H	84 ^H	7.60 ^G	7.60 ^G	7.60 ^G	5.5 ^G	0.0267	5.0E-04 ^G	2.6E-04 ^I	--	--	--
2006 Actual Emission Factors	7,462	455,963	88,890 ton MSW	lbs/10 ⁶ lb Steam	0.0108 ^J	0.408 ^J	0.275 ^J	0.0138 ^A	0.00743 ^L	0.00536 ^L	0.00608 ^A	4.80E-04	7.9E-06 ^A	7.7E-06 ^A	2.19E-04	0.0148	2.26E-08
			7.00 x10 ⁶ CF Natural Gas	lb/10 ⁶ scf	0.60 ^G	100 ^H	84 ^H	7.60 ^G	7.60000 ^G	7.60 ^G	5.5 ^G	0.0267	5.0E-04 ^G	2.6E-04 ^I	--	--	--
2007 Actual Emission Factors	6,576	393,773	73,768 ton MSW	lbs/10 ⁶ lb Steam	0.0067 ^J	0.350 ^J	0.250 ^J	0.014 ^A	0.00743 ^L	0.00536 ^L	0.00608 ^A	2.98E-04	7.9E-06 ^A	7.7E-06 ^A	2.19E-04	0.0148	2.26E-08
			9.85 x10 ⁶ CF Natural Gas	lb/10 ⁶ scf	0.60 ^G	100 ^H	84 ^H	7.60 ^G	7.60 ^G	7.60 ^G	5.5 ^G	0.0267	5.0E-04 ^G	2.6E-04 ^I	--	--	--
2008 Actual Emission Factors	5,421	285,371	45,158 ton MSW	lbs/10 ⁶ lb Steam	0.0284 ^J	0.261 ^J	0.227 ^J	0.014 ^A	0.00743 ^L	0.00536 ^L	0.00608 ^A	1.26E-03	7.9E-06 ^A	7.7E-06 ^A	2.19E-04	0.0148	2.26E-08
			22.24 x10 ⁶ CF Natural Gas	lb/10 ⁶ scf	0.60 ^G	100 ^H	84 ^H	7.60 ^G	7.60 ^G	7.60 ^G	5.5 ^G	0.0267	5.0E-04 ^G	2.6E-04 ^I	--	--	--

^A Based on 5-year average stack tests (see Table A-6).

^B Based on similar method used for fuel oil, where the ratio of SO₃ emissions to SO₂ emissions (5.7/157) is multiplied by the ratio of the molecular weights of H₂SO₄ and SO₃ (98/80), resulting in approximately 4.45% of SO₂ emissions becoming SAM.

^C Based on AP-42, Table 1.3-1. SO₂ is calculated with 142S where S is the sulfur content, 0.5-percent.

^D Based on AP-42, Table 1.3-6.

^E Based on AP-42, Table 1.3-3.

^F Based on AP-42, Table 1.5-1. SO₂ = 0.10S, where S is the sulfur content, 15 gr/cf.

^G Based on AP-42, Table 1.4-2.

^H Based on AP-42, Table 1.4-1.

^I Based on AP-42, Table 1.4-4.

^J Based on annual CEMS data. See Table A-10.

^K Based on AP-42, Table 1.3-11.

^L Based on EPA's PM Calculator where 54% of PM is PM₁₀ and 39% of PM is PM_{2.5}.

^M Based on the 1999 stack test of 0.0073 lb/hr for 2000 through 2004 and the 2005 stack test of 0.014 lb/hr for 2005 through 2008 divided by the steam production rate.

^N For MSW factor, refer to Table A-6.

Checked By: OB
Reviewed By: EP

**TABLE A-3
BASELINE ACTUAL ANNUAL (2000-2008) EMISSIONS FOR MWC UNIT NO. 1
BAY COUNTY, PANAMA CITY**

Source Description	Pollutant Emission Rate (TPY) ^a												
	SO ₂	NO _x	CO	PM	PM ₁₀	PM _{2.5}	VOC	SAM	Lead	Mercury	Fluoride	HCl	Dioxins/Furans
Municipal Waste Combustion Unit 001													
2000 Actual Emission													
MSW	31.56	74.60	72.79	7.23	3.91	2.82	4.61	1.40	0.147	0.019	0.031	17.49	1.01E-05
Natural Gas	1.8E-05	3.0E-03	2.5E-03	2.3E-04	2.3E-04	2.3E-04	1.7E-04	8.0E-07	1.5E-08	7.80E-09	-	-	-
Distillate Oil	0.11	0.030	7.5E-03	3.0E-03	1.5E-03	3.0E-03	3.0E-04	4.7E-03	-	-	0.00006	-	-
Propane	5.3E-05	4.6E-04	2.6E-04	2.5E-05	2.5E-05	2.5E-05	3.5E-05	2.3E-06	-	-	-	-	-
Total	31.67	74.64	72.80	7.24	3.91	2.82	4.61	1.41	0.147	0.019	0.031	17.49	1.01E-05
2001 Actual Emission													
MSW	32.03	75.72	73.88	7.34	3.97	2.86	4.68	1.42	0.149	0.019	0.032	17.75	1.02E-05
Natural Gas	2.7E-05	4.5E-03	3.8E-03	3.4E-04	3.4E-04	3.4E-04	2.5E-04	1.2E-06	2.3E-08	1.17E-08	-	-	-
Total	32.03	75.73	73.89	7.34	3.97	2.86	4.68	1.42	0.149	0.019	0.032	17.75	1.02E-05
2002 Actual Emission													
MSW	33.15	78.35	76.45	7.60	4.10	2.96	4.84	1.47	0.154	0.020	0.033	18.37	1.06E-05
Natural Gas	5.6E-04	0.094	0.079	0.0071	0.0071	0.0071	0.0051	2.5E-05	4.7E-07	2.43E-07	-	-	-
Total	33.15	78.45	76.53	7.61	4.11	2.97	4.85	1.47	0.154	0.020	0.033	18.37	1.06E-05
2003 Actual Emission													
MSW	32.85	77.65	75.77	7.53	4.07	2.94	4.80	1.46	0.153	0.020	0.032	18.20	1.05E-05
Natural Gas	5.0E-04	0.083	0.070	0.0063	0.0063	0.0063	0.0046	2.2E-05	4.2E-07	2.16E-07	-	-	-
Total	32.85	77.74	75.84	7.54	4.07	2.94	4.81	1.46	0.153	0.020	0.032	18.20	1.05E-05
2004 Actual Emission													
MSW	31.22	73.80	72.01	7.16	3.86	2.79	4.56	1.39	0.145	0.019	0.031	17.30	9.96E-06
Natural Gas	5.0E-04	0.084	0.070	0.0063	0.0063	0.0063	0.0046	2.2E-05	4.2E-07	2.17E-07	-	-	-
Total	31.22	73.88	72.08	7.16	3.87	2.80	4.57	1.39	0.145	0.019	0.031	17.30	9.96E-06
2005 Actual Emission													
MSW	30.88	68.80	67.13	4.84	2.61	1.89	2.39	1.37	0.0077	0.0023	0.049	5.21	6.97E-06
Natural Gas	7.5E-04	0.13	0.11	0.0095	0.0095	0.0095	0.0069	3.3E-05	6.3E-07	3.25E-07	-	-	-
Total	30.88	68.93	67.23	4.85	2.62	1.90	2.40	1.37	0.0077	0.0023	0.049	5.21	6.97E-06
2006 Actual Emission													
MSW	3.43	60.16	54.97	4.97	2.68	1.94	2.46	0.153	0.0079	0.0023	0.050	5.35	7.16E-06
Natural Gas	2.1E-03	0.35	0.29	0.027	0.027	0.027	0.019	0.0001	1.8E-06	9.10E-07	-	-	-
Total	3.43	60.51	55.26	5.00	2.71	1.96	2.48	0.153	0.0079	0.0023	0.050	5.35	7.16E-06
2007 Actual Emission													
MSW	3.48	64.84	46.14	4.49	2.43	1.75	2.22	0.155	0.0071	0.0021	0.045	4.84	6.47E-06
Natural Gas	3.0E-03	0.49	0.41	0.037	0.037	0.037	0.027	0.0001	2.5E-06	1.28E-06	-	-	-
Total	3.48	65.33	46.56	4.53	2.46	1.79	2.25	0.155	0.0071	0.0021	0.045	4.84	6.47E-06
2008 Actual Emission													
MSW	2.65	32.72	29.85	3.17	1.71	1.24	1.57	0.118	0.0050	0.0015	0.032	3.42	4.57E-06
Natural Gas	6.7E-03	1.11	0.93	0.085	0.085	0.085	0.061	0.0000	5.6E-06	2.89E-06	-	-	-
Total	2.65	33.827	30.78	3.26	1.80	1.32	1.63	0.118	0.0050	0.0015	0.032	3.42	4.57E-06

TPY = Tons per year.

Notes:

^a See Table A-1 for emission factors.

Checked By: DB
Reviewed By: DB

**TABLE A-4
BASELINE ACTUAL ANNUAL (2000-2008) EMISSIONS FOR MWC UNIT NO. 2
BAY COUNTY, PANAMA CITY**

Source Description	Pollutant Emission Rate (TPY) ^a												
	SO ₂	NO _x	CO	PM	PM ₁₀	PM _{2.5}	VOC	SAM	Lead	Mercury	Fluoride	HCl	Dioxins/Furans
Municipal Waste Combustion Unit 002													
2000 Actual Emissions													
MSW	38.31	88.70	96.44	9.61	5.19	3.75	5.51	1.70	0.170	0.025	0.029	19.75	1.20E-05
Natural Gas	2.1E-05	3.5E-03	2.9E-03	2.7E-04	2.7E-04	2.3E-04	1.9E-04	9.3E-07	1.8E-08	9.1E-09	-	-	-
Distillate Oil	0.11	3.1E-02	7.8E-03	3.1E-03	1.6E-03	3.0E-03	3.1E-04	0.0049	-	-	-	-	-
Propane	5.3E-05	4.6E-04	2.6E-04	2.5E-05	2.5E-05	2.5E-05	3.5E-05	0.00	-	-	-	-	-
Total	38.42	88.73	96.45	9.61	5.19	3.75	5.51	1.71	0.170	0.025	0.029	19.75	1.20E-05
2001 Actual Emissions													
MSW	36.38	84.22	91.57	7.34	3.97	2.86	5.23	1.62	0.162	0.024	0.028	18.75	1.14E-05
Natural Gas	2.4E-05	4.0E-03	3.4E-03	3.0E-04	3.0E-04	3.0E-04	2.2E-04	9.3E-07	2.0E-08	1.0E-08	-	-	-
Total	36.38	84.22	91.57	7.34	3.97	2.86	5.23	1.62	0.162	0.024	0.028	18.75	1.14E-05
2002 Actual Emissions													
MSW	37.61	87.08	94.68	9.44	5.10	3.68	5.41	1.67	0.167	0.025	0.029	19.39	1.18E-05
Natural Gas	5.5E-04	0.092	0.077	0.0070	0.0070	0.0070	0.0050	9.3E-07	4.6E-07	2.4E-07	-	-	-
Total	37.61	87.17	94.76	9.44	5.10	3.69	5.41	1.67	0.167	0.025	0.029	19.39	1.18E-05
2003 Actual Emissions													
MSW	36.24	83.90	91.22	9.09	4.91	3.55	5.21	1.61	0.161	0.024	0.028	18.68	1.14E-05
Natural Gas	5.0E-04	0.083	6.9E-02	0.0063	0.0063	0.0063	0.0045	9.3E-07	4.1E-07	2.1E-07	-	-	-
Total	36.24	83.98	91.29	9.10	4.92	3.55	5.22	1.61	0.161	0.024	0.028	18.68	1.14E-05
2004 Actual Emissions													
MSW	34.75	80.46	87.48	7.16	3.86	2.79	5.00	1.55	0.154	2.3E-02	0.026	17.92	1.09E-05
Natural Gas	4.9E-04	0.081	0.068	0.0062	0.0062	0.0062	0.0045	2.2E-05	4.1E-07	2.1E-07	-	-	-
Total	34.75	80.54	87.55	7.16	3.87	2.80	5.00	1.55	0.154	0.0228	0.026	17.92	1.09E-05
2005 Actual Emissions													
MSW	20.77	76.80	83.51	4.84	2.61	1.89	1.34	0.92	0.0017	0.0017	0.048	3.25	4.97E-06
Natural Gas	7.5E-04	0.13	0.11	0.0095	0.0095	0.0095	0.0069	3.3E-05	6.3E-07	3.3E-07	-	-	-
Total	20.77	76.93	83.61	4.85	2.62	1.90	1.34	0.92	0.0017	0.0017	0.048	3.25	4.97E-06
2006 Actual Emissions													
MSW	2.46	93.10	62.61	4.97	2.68	1.94	1.39	0.109	0.0018	0.0018	0.050	3.37	5.15E-06
Natural Gas	2.1E-03	0.35	0.29	0.027	0.027	0.027	0.019	9.3E-05	1.8E-06	9.1E-07	-	-	-
Total	2.46	93.45	62.91	5.00	2.71	1.96	1.40	0.109	0.0018	0.0018	0.050	3.37	5.15E-06
2007 Actual Emissions													
MSW	1.32	68.85	49.18	4.49	2.43	1.75	1.20	0.059	0.0016	0.0015	0.043	2.91	4.45E-06
Natural Gas	3.0E-03	0.49	0.41	0.037	0.037	0.037	0.027	1.3E-04	2.5E-06	1.3E-06	-	-	-
Total	1.32	69.34	49.59	4.53	2.46	1.79	1.22	0.059	0.0016	0.0015	0.043	2.91	4.45E-06
2008 Actual Emissions													
MSW	4.05	37.20	32.42	3.17	1.71	1.24	0.87	0.180	0.0011	0.0011	0.031	2.110	3.22E-06
Natural Gas	6.7E-03	1.11	0.93	0.085	0.085	0.085	0.061	0.000	5.6E-06	2.9E-06	-	-	-
Total	4.06	38.31	33.36	3.258	1.798	1.322	0.93	0.180	0.0011	0.0011	0.031	2.110	3.22E-06

TPY = Tons per year.

Notes:

^a See Table A-1 for emission factors.

Checked By: AB
Reviewed By: DP

**TABLE A-5
SUMMARY OF BASELINE 2-YEAR AVERAGE ACTUAL (2000-2008) EMISSIONS
BAY COUNTY, PANAMA CITY**

Source Description	EU ID	Pollutant Emission Rate (TPY)													
		SO ₂	NO _x	CO	PM	PM ₁₀	PM _{2.5}	VOC	SAM	Lead	Mercury	Fluoride	HCl	Dioxins/ Furans	
2000 - 2001 Average Emissions															
Municipal Waste Combustion Unit	001	31.85	75.18	73.34	7.29	3.94	2.84	4.65	1.42	0.15	0.019	0.031	17.62	1.01E-05	
Municipal Waste Combustion Unit	002	37.40	86.48	94.01	8.48	4.58	3.31	5.37	1.66	0.17	0.025	0.028	19.25	1.17E-05	
- Total		69.25	161.66	167.35	15.77	8.52	6.15	10.02	3.08	0.31	0.044	0.060	36.87	2.19E-05	
2001 - 2002 Average Emissions															
Municipal Waste Combustion Unit	001	32.59	77.09	75.21	7.47	4.04	2.92	4.77	1.45	0.15	0.020	0.032	18.06	1.04E-05	
Municipal Waste Combustion Unit	002	37.00	85.70	93.17	8.39	4.53	3.28	5.32	1.65	0.16	0.024	0.028	19.07	1.16E-05	
- Total		69.59	162.79	168.37	15.87	8.57	6.19	10.09	3.09	0.32	0.044	0.060	37.13	2.20E-05	
2002 - 2003 Average Emissions															
Municipal Waste Combustion Unit	001	33.00	78.09	76.18	7.57	4.09	2.96	4.83	1.47	0.15	0.020	0.033	18.28	1.05E-05	
Municipal Waste Combustion Unit	002	36.93	85.58	93.02	9.27	5.01	3.62	5.32	1.64	0.16	0.024	0.028	19.04	1.16E-05	
- Total		69.93	163.67	169.20	16.84	9.10	6.58	10.14	3.11	0.32	0.044	0.061	37.32	2.21E-05	
2003 - 2004 Average Emissions															
Municipal Waste Combustion Unit	001	32.04	75.81	73.96	7.35	3.97	2.87	4.69	1.42	0.15	0.019	0.032	17.75	1.02E-05	
Municipal Waste Combustion Unit	002	35.50	82.26	89.42	8.13	4.39	3.17	5.11	1.58	0.16	0.023	0.027	18.30	1.11E-05	
- Total		67.53	158.07	163.37	15.48	8.36	6.04	9.80	3.00	0.31	0.043	0.059	36.05	2.14E-05	
2004 - 2005 Average Emissions															
Municipal Waste Combustion Unit	001	31.05	71.40	69.66	6.01	3.25	2.35	3.48	1.38	0.0764	0.0105	0.040	11.26	8.47E-06	
Municipal Waste Combustion Unit	002	27.76	78.74	85.58	6.01	3.25	2.35	3.17	1.23	0.0780	0.0123	0.037	10.58	7.94E-06	
- Total		58.81	150.14	155.24	12.01	6.49	4.69	6.66	2.62	0.1544	0.0228	0.077	21.84	1.64E-05	
2005 - 2006 Average Emissions															
Municipal Waste Combustion Unit	001	17.16	64.72	61.25	4.92	2.67	1.93	2.44	0.76	0.0078	0.0023	0.049	5.28	7.06E-06	
Municipal Waste Combustion Unit	002	11.61	85.19	73.26	4.92	2.67	1.93	1.37	0.52	0.0018	0.0017	0.049	3.31	5.06E-06	
- Total		28.77	149.90	134.51	9.84	5.33	3.86	3.81	1.28	0.0095	0.0040	0.098	8.60	1.21E-05	
2006 - 2007 Average Emissions															
Municipal Waste Combustion Unit	001	3.46	62.92	50.91	4.76	2.59	1.88	2.36	0.15	0.0075	0.0022	0.048	5.10	6.81E-06	
Municipal Waste Combustion Unit	002	1.89	81.39	56.25	4.76	2.59	1.88	1.31	0.08	0.0017	0.0016	0.047	3.14	4.80E-06	
- Total		5.35	144.31	107.16	9.53	5.17	3.75	3.68	0.24	0.0092	0.0039	0.094	8.24	1.16E-05	
2007 - 2008 Average Emissions															
Municipal Waste Combustion Unit	001	3.07	49.58	38.67	3.89	2.13	1.56	1.94	0.14	0.0061	0.0018	0.039	4.13	5.52E-06	
Municipal Waste Combustion Unit	002	2.69	53.82	41.48	3.89	2.13	1.56	1.08	0.12	0.0013	0.0013	0.037	2.51	3.84E-06	
- Total		5.76	103.40	80.14	7.79	4.26	3.11	3.02	0.26	0.0074	0.0031	0.076	6.64	9.36E-06	
Highest Consecutive 2-Year Average		'02 - '03	'02 - '03	'02 - '03	'02 - '03	'02 - '03	'02 - '03	'02 - '03	'02 - '03	'02 - '03	'02 - '03	'02 - '03	'05 - '06	'02 - '03	'02 - '03
		69.93	163.67	169.20	16.84	9.10	6.58	10.14	3.11	0.317	0.044	0.098	37.32	2.21E-05	

Checked by: AB
Reviewed by: AB

**TABLE A-7
STACK TESTS AND EMISSIONS DATA FOR MWC UNIT NO. 1
BAY COUNTY, PANAMA CITY**

Test Date	Steam Production Rate (lb/hr)	Gas Flow Rate (dscm @ 7% O ₂)	Flue Gas Temp (°F)	Reporting Year	Averaging Period	Carbon Monoxide (CO)					Nitrogen Oxide (NO _x)							
						Stack Test Emission Rate		Current Limit (ppmvd @ 7% O ₂)	Adjusted Emissions (lb/hr)	Emission Factor (lb/10 ³ lb steam)	5-Year Average Emission Rate (lb/10 ³ lb steam)	Stack Test Emission Rate		Current Limit (ppmvd @ 7% O ₂)	Adjusted Emissions (lb/hr)	Emission Factor (lb/10 ³ lb steam)	5-Year Average Emission Rate (lb/10 ³ lb steam)	
						ppm @ 7% O ₂	lb/hr					ppmvd @ 7% O ₂	lb/hr					
<i>Municipal Waste Combustion Unit (EU 001)</i>																		
12/15-16/1999	59,937	24,557	412			333.46	42.28	250	31.70	0.529	-		79.49	16.58	170	16.58	0.277	-
12/12-15/2000	63,573	24,407	394	2000	1999-2005	122.98	10.88	250	10.88	0.171	0.300		88.70	18.14	170	18.14	0.285	0.308
12/11-15/2001	64,585	24,827	390	2001	1999-2005	91.61	9.94	250	9.94	0.154	0.300		88.63	15.76	170	15.76	0.244	0.308
11/17-20/2002	62,984	27,191	413	2002	1999-2005	146.13	17.32	250	17.32	0.275	0.300		111.75	21.80	170	21.80	0.346	0.308
11/10-13/2003	64,281	27,537	401	2003	1999-2005	249.37	29.91	250	29.91	0.465	0.300		100.46	19.88	170	19.88	0.309	0.308
				2004	1999-2005						0.300							0.308
6/27-29/2005	64,200	28,778	314	2005	1999-2005	106.25	13.30	250	13.30	0.207	0.300		120.28	24.71	170	24.71	0.385	0.308

Test Date	Steam Production Rate (lb/hr)	Gas Flow Rate (dscm @ 7% O ₂)	Flue Gas Temp (°F)	Reporting Year	Averaging Period	Sulfur Dioxide (SO ₂)					Volatile Organic Compounds (VOC)			
						Stack Test Emission Rate		Current Limit (ppmvd @ 7% O ₂)	Adjusted Emissions (lb/hr)	Emission Factor (lb/10 ³ lb steam)	5-Year Average Emission Rate (lb/10 ³ lb steam)	Stack Test ^a		5-Year Average Emission Rate (lb/10 ³ lb steam)
						ppm @ 7% O ₂	lb/hr					Emission Rate (lb/hr)	Emission Factor (lb/10 ³ lb steam)	
<i>Municipal Waste Combustion Unit (EU 001)</i>														
12/15-16/1999	59,937	24,557	412			88.19	25.41	31	8.93	0.149	-	0.50	0.00840	-
12/12-15/2000	63,573	24,407	394	2000	1999-2003	50.1	11.93	31	7.38	0.116	0.130	2.99	0.0470	0.0190
12/11-15/2001	64,585	24,827	390	2001	1999-2003	115.1	28.55	31	7.69	0.119	0.130	0.82	0.0127	0.0190
11/17-20/2002	62,984	27,191	413	2002	1999-2003	62.15	16.89	31	8.42	0.134	0.130	0.73	0.0116	0.0190
11/10-13/2003	64,281	27,537	401	2003	1999-2003	47.18	13.00	31	8.54	0.133	0.130	0.99	0.0153	0.0190
				2004	1999-2003						0.130	-	-	0.0190
6/27-29/2005	64,200	28,778	314			43.45	12.43	31	8.87	0.138	0.138	0.47	0.00737	-
10/31-11/4/2005	64,467	24,167	326	2005	2005-2008							0.38	0.00595	0.0107
11/15-19/2006	64,267	27,752	310	2006	2005-2008							0.47	0.0073	0.0107
11/6-10/2007	62,533	27,145	317	2007	2005-2008							0.78	0.0125	0.0107
12/1-4/2008	63,067	26,870	312	2008	2005-2008							1.29	0.0205	0.0107

^a Current limit is 7.1 lb/hr; no adjustments to stack test emission rates were necessary.

Checked By: DB
Reviewed By: DB

TABLE A-8
STACK TESTS AND EMISSIONS DATA FOR MWC UNIT NO. 2
BAY COUNTY, PANAMA CITY

Test Date	Steam Production Rate (lb/hr)	Gas Flow Rate (dscm @ 7% O ₂)	Flue Gas Temp (°F)	Stack Test Emission Rate				Reporting Year	Averaging Period	5-Year Average Emission Rate (lb/10 ³ lb steam)
				Emission Rate		Current Limit	Adjusted Emissions			
Particulate Matter (PM)										
				mg/dscm @ 7% O ₂	lb/hr	(mg/dscm @ 7% O ₂)	(lb/hr)	(lb/10 ³ lb Steam)		
12/15-16/1999	64,687	23,987	447	39.58	3.48	27	2.36	0.0355		
12/12-15/2000	64,921	26,339	405	34.50	3.40	27	2.66	0.0409	2000	1999-2004
12/11-15/2001	64,457	23,273	418	28.37	2.55	27	2.43	0.0377	2001	1999-2004
11/17-20/2002	62,869	28,024	397	20.24	2.11	27	2.11	0.0335	2002	1999-2004
11/10-13/2003	62,816	25,124	431	40.98	3.87	27	2.55	0.0406	2003	1999-2004
									2004	1999-2004
6/27-29/2005	64,433	29,910	312	2.33	0.26	27	0.26	0.0041		
10/31-11/4/2005	62,533	26,410	328	1.56	0.15	27	0.15	0.0024	2005	2005-2008
11/15-19/2006	62,400	26,252	307	6.94	0.68	27	0.68	0.0109	2006	2005-2008
11/6-10/2007	63,533	29,449	308	17.67	1.95	27	1.95	0.0306	2007	2005-2008
12/1-4/2008	64,400	30,709	299	11.63	1.34	27	1.34	0.0208	2008	2005-2008
Lead (Pb)										
				mg/dscm @ 7% O ₂	lb/hr	(mg/dscm @ 7% O ₂)	(lb/hr)	(lb/10 ³ lb Steam)		
12/15-16/1999	64,687	23,987	447	0.831	0.075	0.49	0.0440	6.81E-04		
12/12-15/2000	64,707	24,218	424	0.275	0.028	0.49	0.0277	4.28E-04	2000	1999-2004
12/11-15/2001	64,307	24,296	413	0.474	0.047	0.49	0.0470	7.31E-04	2001	1999-2004
11/17-20/2002	58,840	22,950	414	0.571	0.069	0.49	0.0591	1.01E-03	2002	1999-2004
11/10-13/2003	64,199	28,692	443	0.360	0.040	0.49	0.0400	6.23E-04	2003	1999-2004
12/4/2004	64,061	26,460	420	0.354	0.035	0.49	0.0353	5.52E-04	2004	1999-2004
6/27-29/2005	64,400	29,777	316	0.00400	0.000374	0.49	0.000374	5.80E-06		
10/31-11/4/2005	62,533	26,410	328	0.00273	0.000261	0.49	0.000261	4.18E-06	2005	2005-2008
11/15-19/2006	62,400	26,252	307	0.00976	0.000954	0.49	0.000954	1.53E-05	2006	2005-2008
11/6-10/2007	63,533	29,449	308	0.00317	0.000346	0.49	0.000346	5.45E-06	2007	2005-2008
12/1-4/2008	64,400	30,709	299	0.00495	0.000568	0.49	0.000568	8.83E-06	2008	2005-2008
Mercury (Hg)										
				mg/dscm @ 7% O ₂	lb/hr	(mg/dscm @ 7% O ₂)	(lb/hr)	(lb/10 ³ lb Steam)		
12/15-16/1999	64,687	23,987	447	0.0894	0.00623	0.070	0.0062	9.64E-05		
12/12-15/2000	62,720	24,914	411	0.0344	0.00367	0.070	0.0037	5.85E-05	2000	1999-2003
12/11-15/2001	63,241	27,341	413	0.0730	0.00740	0.070	0.0074	1.17E-04	2001	1999-2003
11/17-20/2002	64,280	26,876	411	0.0520	0.00419	0.070	0.0042	6.52E-05	2002	1999-2003
11/10-13/2003	63,302	31,608	443	0.0747	0.0100	0.070	0.010	1.58E-04	2003	1999-2003
12/4/2004									2004	1999-2003
6/25/2005	63,650	29,740	303	0.00563	0.000625	0.070	0.00062	9.81E-06		
8/25/2005	64,550	28,335	316	0.00742	0.000838	0.070	0.00084	1.30E-05		
8/27-29/2005	64,033	29,777	316	0.00933	0.000990	0.070	0.00099	1.55E-05		
10/31-11/4/2005	62,533	26,410	328	0.00311	0.000298	0.070	0.00030	4.76E-06	2005	2005-2008
11/15-19/2006	62,400	26,252	307	0.00179	0.000177	0.070	0.00018	2.84E-06	2006	2005-2008
11/6-10/2007	63,533	29,449	308	0.00587	0.000645	0.070	0.00065	1.02E-05	2007	2005-2008
12/1-4/2008	64,400	30,709	299	0.00300	0.000345	0.070	0.00034	5.35E-06	2008	2005-2008
Hydrogen Chloride (HCl)										
				mg/dscm @ 7% O ₂	lb/hr	(mg/dscm @ 7% O ₂)	(lb/hr)	(lb/10 ³ lb Steam)		
11/17-23/2002	62,869	25,476	397	429.97	67.80	31	4.89	0.0777	2000	
									2001	
									2002	2002
									2003	
									2004	
6/25-29/2005	64,433	29,910	312	290.94	49.33	31	5.26	0.0816		
10/31-11/4/2005	64,500	31,692	325	3.30	0.53	31	0.53	0.0083	2005	2005-2008
11/15-19/2006	64,700	27,728	310	2.47	0.39	31	0.39	0.0060	2006	2005-2008
11/6-10/2007	59,167	29,604	308	6.18	1.033	31	1.03	0.0175	2007	2005-2008
1/19/2009	60,733	26,490	222	11.11	1.66	31	1.66	0.0274	2008	2005-2008
Dioxins/Furans (PCDD/PCDF)										
				ng/dscm @ 7% O ₂	lb/hr	(ng/dscm @ 7% O ₂)	(lb/hr)	(lb/10 ³ lb Steam)		
11/17-23/2002	63,134	26,664	396	928	9.25E-05	30	2.99E-06	4.74E-08	2000	2002
									2001	2002
									2002	2002
									2003	2002
									2004	2002
9/12-15/2005	62,200	27,864	312	21.36	2.24E-06	30	2.24E-06	3.59E-08		
01/3-8/2006	64,067	27,347	328	4.38	4.51E-07	30	4.51E-07	7.03E-09	2005	2005-2008
11/15-19/2006	61,200	25,085	306	5.04	4.71E-07	30	4.71E-07	7.70E-09	2006	2005-2008
11/6-10/2007	63,133	29,340	310	14.80	1.65E-06	30	1.65E-06	2.62E-08	2007	2005-2008
12/1-4/2008	63,633	27,823	303	21.68	2.30E-06	30	2.30E-06	3.61E-08	2008	2005-2008

Note: The 6/25-29/2005 test for Hydrogen Chloride is not representative of new control equipment. Therefore, it was not used in the 5-year average.

Checked By: AB
Reviewed By: OB

**TABLE A-9
STACK TESTS AND EMISSIONS DATA FOR MWC UNIT NO. 2
BAY COUNTY, PANAMA CITY**

Test Date	Steam Production Rate (lb/hr)	Gas Flow Rate (dscm @ 7% O ₂)	Flue Gas Temp (°F)	Reporting Year	Averaging Period	Carbon Monoxide (CO)					Nitrogen Oxide (NO _x)						
						Emission Rate		Current Limit (ppmvd @ 7% O ₂)	Adjusted Emissions (lb/hr)	Emission Factor (lb/10 ³ lb steam)	5-Year Average Emission Rate (lb/10 ³ lb steam)	Stack Test		Current Limit (ppmvd @ 7% O ₂)	Adjusted Emissions (lb/hr)	Emission Factor (lb/10 ³ lb steam)	5-Year Average Emission Rate (lb/10 ³ lb steam)
						ppmvd @ 7% O ₂	lb/hr					ppmvd @ 7% O ₂	lb/hr				
<i>Municipal Waste Combustion Unit (EU 002)</i>																	
12/16/1999	63,577	28,202	455		1999-2005	240.32	38.17	250	38.17	0.600	--	83.13	21.79	170	21.79	0.343	--
12/15/2000	62,720	24,914	411	2000	1999-2005	122.98	17.54	250	17.54	0.280	0.380	88.70	20.86	170	20.86	0.333	0.349
12/15/2001	63,453	25,829	414	2001	1999-2005	96.08	12.76	250	12.76	0.201	0.380	96.83	20.43	170	20.43	0.322	0.349
11/20/2002	62,091	27,182	399	2002	1999-2005	237.98	28.10	250	28.10	0.453	0.380	117.98	22.93	170	22.93	0.369	0.349
11/13/2003	64,199	28,692	443	2003	1999-2005	350.73	43.51	250	31.02	0.483	0.380	115.70	23.64	170	23.64	0.368	0.349
				2004	1999-2005	--	--	--	--	--	0.380	--	--	--	--	--	0.349
6/29/2005	64,400	28,215	296	2005	1999-2005	136.50	16.81	250	16.81	0.261	0.380	114.72	23.19	170	23.19	0.360	0.349

Test Date	Steam Production Rate (lb/hr)	Gas Flow Rate (dscm @ 7% O ₂)	Flue Gas Temp (°F)	Reporting Year	Averaging Period	Sulfur Dioxide (SO ₂)					Volatile Organic Compounds (VOC)			
						Emission Rate		Current Limit (ppmvd @ 7% O ₂)	Adjusted Emissions (lb/hr)	Emission Factor (lb/10 ³ lb steam)	5-Year Average Emission Rate (lb/10 ³ lb steam)	Stack Test ^a		5-Year Average Emission Rate (lb/10 ³ lb steam)
						ppmvd @ 7% O ₂	lb/hr					Emission Rate (lb/hr)	Emission Factor (lb/10 ³ lb steam)	
<i>Municipal Waste Combustion Unit (EU 002)</i>														
12/16/1999	63,577	28,202	455		1999-2003	69.84	25.28	31	11.22	0.177	--	0.66	0.0103	--
12/15/2000	62,720	24,914	411	2000	1999-2003	50.13	16.42	31	10.16	0.162	0.151	3.53	0.0563	0.022
12/15/2001	63,453	25,829	414	2001	1999-2003	83.36	24.57	31	9.14	0.144	0.151	0.59	0.0094	0.022
11/20/2002	62,091	27,182	399	2002	1999-2003	46.86	12.70	31	8.40	0.135	0.151	0.55	0.0089	0.022
11/13/2003	64,199	28,692	443	2003	1999-2003	51.21	14.46	31	8.75	0.136	0.151	1.51	0.0236	0.022
				2004	1999-2003	--	--	--	--	--	0.151	--	--	0.022
6/29/2005	64,400	28,215	296		2005-2008	21.56	6.08	31	6.08	0.094	0.094	0.41	0.00637	0.0061
11/4/2005	64,500	28,684	325	2005	2005-2008	--	--	--	--	--	--	0.31	0.00475	0.0061
11/19/2006	64,700	27,728	310	2006	2005-2008	--	--	--	--	--	--	0.37	0.00572	0.0061
11/10/2007	59,167	29,604	308	2007	2005-2008	--	--	--	--	--	--	0.31	0.00530	0.0061
12/4/2008	62,600	27,887	301	2008	2005-2008	--	--	--	--	--	--	0.52	0.00825	0.0061

^a Current limit is 7.1 lb/hr; no adjustments to stack test emission rates were necessary.

Checked by: DB
Reviewed by: DB

**TABLE A-10
CEMS DATA FOR MWC UNITS NO. 1 AND 2
BAY COUNTY, PANAMA CITY**

Year	Steam Production Rate (10 ³ lb of Steam/yr)	MSW Processed (tons)	Total Gas Flow Rate ^a (dscf/yr corrected @ 7% O ₂)	Carbon Monoxide (CO)			Nitrogen Oxides (NO _x)			Sulfur Dioxide (SO ₂)		
				CEMS Average Emission Rate (ppmvd @ 7% O ₂)	Total Emissions (lb/yr)	Emission Factor (lb/10 ³ lb steam)	CEMS Average Emission Rate (ppmvd @ 7% O ₂)	Total Emissions (lb/yr)	Emission Factor (lb/10 ³ lb steam)	CEMS Average Emission Rate (ppmvd corrected @ 7% O ₂)	Total Emissions (lb/yr)	Emission Factor (lb/10 ³ lb steam)
2006												
MWC Unit 001	459,117	89,505	11,989,540,293	126.2	109,941	0.239	84.10	120,315	0.262	4.80	6,863	0.0149
MWC Unit 002	455,963	88,890	11,482,497,415	150.1	125,222	0.275	135.89	186,192	0.408	3.59	4,919	0.0108
2007												
MWC Unit 001	415,180	77,780	10,949,597,116	116.0	92,284	0.222	99.25	129,676	0.312	5.33	6,964	0.0168
MWC Unit 002	393,773	73,768	11,051,362,967	122.5	98,360	0.250	104.42	137,699	0.350	2.00	2,637	0.0067
2008												
MWC Unit 001	293,217	46,891	7,714,451,809	106.5	59,693	0.204	71.08	65,431	0.223	5.75	5,293	0.0181
MWC Unit 002	285,371	45,158	7,761,009,906	115.0	64,846	0.227	80.33	74,392	0.261	8.75	8,103	0.0284

^a Based on the annual average gas flow rate during stack tests for a given year (see Tables A-13 and A-14).

Checked by: DB
Reviewed by: DB

**TABLE A-11
BASELINE ACTUAL OPERATING CONDITIONS FOR MWC UNIT NO. 1
BAY COUNTY, PANAMA CITY**

Year	Operating Hours (hours/yr)	Steam Generated (10 ³ lb/yr)	Fuel Usage					Heat Input				
			Distillate Oil (10 ³ gal/yr)	Natural Gas (10 ⁶ cf)	Waste Wood/Bark (TPY)	Propane (10 ³ gal/yr)	MSW (TPY)	Distillate Oil (MMBtu/yr)	Natural Gas (MMBtu/yr)	Propane (MMBtu/yr)	MSW (MMBtu/yr)	Total Heat Input (MMBtu/yr)
MWC Unit (EU 001)												
2000	7,741	484,919	3.00	0.06	--	0.07	84,852	408	63	6.44	763,668	764,145
2001	7,910	492,191	--	0.09	--	--	90,973	--	95	--	818,757	818,852
2002	8,211	509,294	--	1.87	--	--	93,107	--	1,964	--	837,963	839,927
2003	8,135	504,740	--	1.66	--	--	95,931	--	1,743	--	863,379	865,122
2004	7,758	479,689	--	1.67	--	--	94,093	--	1,754	--	658,651	660,405
2005	7,227	447,210	--	2.50	--	--	93,242	--	2,625	--	652,694	655,319
2006	7,406	459,117	--	7.00	--	--	89,505	--	7,350	--	626,533	633,883
2007	6,909	415,180	--	9.85	--	--	77,780	--	10,343	--	544,457	554,799
2008	5,416	293,217	--	22.24	--	--	46,891	--	23,350	--	328,240	351,590
Maximum:	8,211	509,294	3.00	22.24		0.07	95,931	408	23,350	6.44	863,379	865,122
Average:	7,413	453,951		5.22			85,153		5,476		677,149	682,671
Minimum:	5,416	293,217		0.06			46,891		63		328,240	351,590

MSW: Municipal Solid Waste.

Checked by: DB
Reviewed by: DB

**TABLE A-12
BASELINE ACTUAL OPERATING CONDITIONS FOR MWC UNIT NO. 2
BAY COUNTY, PANAMA CITY**

Year	Operating Hours (hours/yr)	Steam Generated (10 ³ lb/yr)	Fuel Usage					Heat Input				Total Heat Input (MMBtu/yr)
			Distillate Oil (10 ³ gal/yr)	Natural Gas (10 ⁶ cf)	Waste Wood/Bark (TPY)	Propane (10 ³ gal/yr)	MSW (TPY)	Distillate Oil (MMBtu/yr)	Natural Gas (MMBtu/yr)	Propane (MMBtu/yr)	MSW (MMBtu/yr)	
<i>MWC Unit (EU 002)</i>												
2000	8,025	508,062	3.10	0.07	--	0.07	87,966	422	74	6.44	791,694	792,196
2001	7,812	482,414	--	0.08	--	--	89,846	--	84	--	628,922	629,006
2002	8,026	498,812	--	1.83	--	--	91,227	--	1,922	--	638,589	640,511
2003	7,948	480,553	--	1.65	--	--	95,242	--	1,733	--	666,694	668,427
2004	7,521	460,883	--	1.62	--	--	91,129	--	1,701	--	637,903	639,604
2005	7,147	439,935	--	2.50	--	--	92,499	--	2,625	--	647,493	650,118
2006	7,462	455,963	--	7.00	--	--	88,890	--	7,350	--	622,228	629,578
2007	6,576	393,773	--	9.85	--	--	73,768	--	10,343	--	516,375	526,718
2008	5,421	285,371	--	22.24	--	--	45,158	--	23,350	--	316,104	339,454
Maximum:	8,026	508,062	3.10	22.24		0.07	95,242	422	23,350	6.44	791,694	792,196
Average:	7,326	445,085		5.20			83,969		5,464		607,334	612,846
Minimum:	5,421	285,371		0.07			45,158		74		316,104	339,454

MSW: Municipal Solid waste.

Checked by: DB
Reviewed by: DB

**TABLE A-13
STACK GAS FLOW RATE HISTORY- UNIT NO. 1
BAY RESOURCE MANAGEMENT CENTER**

Date	Pollutant	Steam Rate (lb/hr)	Stack Gas Flow Rate		Flue Gas Temp (°F)	Oxygen (%)	Corrected Flow Rate (dscfm @ 7% O ₂)	Flow/Steam Ratio (dscf @ 7% O ₂ / lb Steam)
			acfm	dscfm				
Original Air Pollution Control Equipment								
12/15/1999	PM	61,847	56,065	27,884	421	9.2	23,502	22.8
12/16/1999	F	59,940	53,141	26,851	412	8.1	24,741	24.8
12/12/2000	PM	64,585	47,085	24,155	390	7.8	22,775	21.2
12/15/2000	Lead	64,936	47,449	23,943	400	6.9	24,114	22.3
12/13/2000	Hg	63,374	48,496	25,304	390	7.4	24,581	23.3
12/14/2000	Criteria	63,573	47,382	24,232	394	6.9	24,405	23.0
12/11/2001	PM	64,718	45,854	23,786	390	7.2	23,446	21.7
12/14/2001	Criteria	64,585	48,740	24,827	390	7.0	24,827	23.1
12/15/2001	Hg	64,555	48,806	23,268	387	7.6	22,271	20.7
2/12/2002	Lead	64,563	52,197	25,206	422	7.1	25,026	23.3
11/17/2002	PM	64,757	56,715	29,201	401	8.3	26,489	24.5
11/19/2002	Criteria	64,585	61,595	31,723	413	9.0	27,191	25.3
11/20/2002	Lead	64,563	49,998	25,991	399	9.2	21,907	20.4
11/19/2002	Hg	64,563	61,595	31,723	413	9.0	27,191	25.3
11/17-23/2002	D/F	64,525	52,885	27,204	401	8.7	23,901	22.2
11/17-23/2002	HCl	64,757	56,715	29,201	401	8.3	26,489	24.5
11/11/2003	PM	64,369	61,135	31,614	405	9.2	26,646	24.8
11/12/2003	Criteria	64,281	59,509	30,597	401	8.4	27,537	25.7
	Lead							
11/11/2003	Hg	64,271	54,576	28,425	398	8.6	25,176	23.5
1/12/2004	Lead	64,327	72,232	35,471	466	9.7	28,630	26.7
12/4/2004	Lead	63,837	63,656	32,874	417	9.3	27,473	25.8
	AVERAGE=	64,072	54,563	27,785	405	8.2	25,158	23.6
	MAXIMUM=	64,936	72,232	35,471	466	9.7	28,630	26.7
New Air Pollution Control Equipment								
6/27/2005	Hg	64,500	69,317	36,995	323	9.9	29,332	27.3
6/28/2005	PM	63,933	73,457	39,030	332	10.6	28,994	27.2
6/29/2005	Criteria	64,200	66,626	36,005	314	9.8	28,778	26.9
6/27/2005	Lead/Hg	64,500	69,317	36,995	323	9.9	29,332	27.3
6/28/2005	F/VOC	64,233	71,182	38,468	330	10.1	29,868	27.9
9/14/2005	D/F	64500	66,411	36065	318	10.0	28,466	26.5
9/14/2005	D/F	64500	69,041	37059	324	10.1	28,853	26.8
10/31/2005	PM/Pb/Hg	64,000	65,216	35,897	328	10.7	26,410	24.8
11/1/2005	VOC	64,467	64,399	34,419	326	11.2	24,167	22.5
11/19/2006	PM/Pb/Hg	64,500	70,335	37,140	314	10.6	27,669	25.7
11/19/2006	D/F	64,200	69,964	37478	315	10.3	28,564	26.7
11/16/2006	VOC	64,267	74,838	40,054	310	11.3	27,752	25.9
							Average 2006:	26.1
11/9/2007	PM/Pb/Hg	64,033	76,481	41,268	321	11.3	28,504	26.7
11/8/2007	VOC	62,533	73,011	40,003	317	11.5	27,145	26.0
11/9/2007	D/F	64200	73,497	40301	317	11.2	28,211	26.4
							Average 2007:	26.4
12/2/2008	PM/Pb/Hg	63,867	71,619	40,792	311	11.1	28,758	27.0
12/3/2008	VOC	63,067	71,880	40,581	312	11.7	26,870	25.6
12/1-4/2008	D/F	64600	71,735	40526	312	11.2	28,368	26.3
							Average 2008:	26.3
	AVERAGE=	64,088	70,388	38,150	320	10.7	28,098	26.3
	MAXIMUM=	64,500	76,481	41,268	332	11.7	29,868	27.9

Checked by: DB
Reviewed by: RB

**TABLE A-14
STACK GAS FLOW RATE HISTORY- UNIT NO. 2
BAY RESOURCE MANAGEMENT CENTER**

Date	Pollutant	Steam Rate (lb/hr)	Stack Gas Flow Rate		Flue Gas Temp. (°F)	Oxygen (%)	Corrected Flow Rate (dscfm @ 7% O ₂)	Flow/Steam Ratio (dscf @ 7% O ₂ / lb Steam)
			acfm	dscfm				
Original Air Pollution Control Equipment								
12/15/1999	PM	64,690	61,935	30809	447	10.1	23,987	22.2
12/16/1999	F	63,580	66,331	32100	455	8.1	29,578	27.9
12/12/2000	PM	64,921	55,659	28149	405	7.9	26,339	24.3
12/15/2000	Lead	64,707	54,218	26909	424	8.4	24,218	22.5
12/13/2000	Hg	63,374	48,496	25304	390	7.4	24,581	23.3
12/14/2000	Criteria	62,720	55,730	28590	411	8.8	24,914	23.8
12/11/2001	PM	64,457	52,645	26490	418	8.7	23,273	21.7
12/14/2001	Criteria	63,453	54,780	27603	414	7.9	25,829	24.4
12/15/2001	Hg	63,241	54,494	27538	413	7.1	27,341	25.9
2/12/2002	Lead	--	--	--	--	--	--	--
11/17/2002	PM	62,869	56,932	29722	397	7.8	28,024	26.7
11/19/2002	Criteria	62,091	62,207	32526	399	9.3	27,182	26.3
11/20/2002	Lead	58,840	62,982	32455	414	11.1	22,950	23.4
11/19/2002	Hg	64,280	63,573	33006	411	9.6	26,876	25.1
11/17-23/2002	D/F	63,134	58,244	30598	396	8.8	26,664	25.3
11/17-23/2002	HCl	62,869	56,932	29722	397	7.8	28,024	26.7
11/11/2003	PM	62,816	61,811	31127	431	9.7	25,124	24.0
11/11/2003	Criteria	64,199	67,035	33755	443	9.1	28,692	26.8
11/11/2003	Lead	64,199	67,035	33755	443	9.1	28,692	26.8
11/11/2003	Hg	62,464	72,828	36271	443	8.8	31,608	30.4
1/12/2004	Lead	--	--	--	--	--	--	--
12/4/2004	Lead	64,061	63,829	32782	420	9.7	26,460	24.8
	AVERAGE=	63,348	59,885	30,461	419	8.8	26,518	25.1
	MAXIMUM=	64,921	72,828	36,271	455	11.1	31,608	30.4
New Air Pollution Control Equipment								
6/27/2005	PM	64,433	67,134	36318	312	9.5	29,910	27.9
6/28/2005	Criteria	64,400	63,948	35586	296	9.9	28,215	26.3
6/29/2005	Lead/Hg	64,033	66,691	35540	316	10.1	27,747	26.0
6/27/2005	F/VOC	63,867	66,276	37047	301	9.7	29,823	28.0
6/28/2005	D/F	64,700	64,074	33747	321	9.5	27,721	25.7
9/14/2005	D/F	62,200	67,956	36801	312	10.4	27,864	26.9
9/14/2005	PM/Pb/Hg	62,500	65,776	35395	339	10.9	25,535	24.5
10/31/2005	VOC	64,500	68,851	38136	325	10.5	28,684	26.7
11/1/2005								
11/19/2006	PM/Pb/Hg	62,400	66,117	36032	307	10.8	26,252	25.2
11/19/2006	D/F	61,200	65,256	35119	306	11.0	25,085	24.6
11/16/2006	VOC/HCl	64,700	68,072	35712	310	10.1	27,728	25.7
							Average 2006:	25.2
11/9/2007	PM/Pb/Hg	63,500	71,013	36486	308	9.7	29,449	27.8
11/8/2007	D/F	64,200	73,497	40301	317	11.2	28,211	26.4
11/9/2007	VOC/HCl	59,200	71,782	38129	308	10.1	29,604	30.0
							Average 2007:	28.1
12/2/2008	PM/Pb/Hg	64,400	75,055	42993	299	11.0	30,709	28.6
12/3/2008	VOC	62,600	76,415	44016	301	12.1	27,887	26.7
12/1-4/2008	HCl	63,600	72,580	42340	303	11.8	27,823	26.2
							Average 2008:	27.2
	AVERAGE=	63,320	68,853	37,629	311	10.5	28,132	26.7
	MAXIMUM=	64,700	76,415	44,016	339	12.1	30,709	30.0

Checked by: DB
Reviewed by: DB

APPENDIX B

EMISSION FACTORS FROM ANNUAL OPERATING REPORTS

**TABLE B-1
ANNUAL (1999-2008) EMISSIONS FROM ANNUAL OPERATING REPORTS FOR THE MWC UNIT NO. 1
BAY COUNTY, PANAMA CITY**

Source Description	EU ID	Annual Operation (hr/yr)	Annual Fuel Usage	Units	Pollutant Emission Factors												
					SO ₂	NO _x	CO	PM	PM ₁₀	PM _{2.5}	VOC	SAM	Lead	Mercury	Fluoride	HCl	Dioxins/Furans
Municipal Waste Combustion Unit 001																	
2000 Actual Emission Factors		7,741	84,852 ton MSW	lbs/hr	11.93 ^A	18.14 ^A	10.88 ^A	1.56 ^A	1.56 ^A	--	2.99 ^A	1.50 ^B	2.3E-02 ^A	3.4E-03 ^A	7.7E-03 ^C	-- ^D	
			0.06 x10 ⁶ CF Natural Gas	lb/10 ⁶ scf	0.60 ^E	100 ^F	84 ^F	7.60 ^E	7.60 ^E	--	5.5 ^E	--	5.0E-04 ^E	0.00026 ^L	--	--	
			3.00 x10 ³ gal Distillate Oil	lb/10 ³ gal	71.00 ^G	20.00 ^G	5.00 ^G	2.00 ^H	1.00 ^H	--	0.20 ^I	--	--	--	--	--	
			0.07 x10 ³ gal Propane	lb/10 ³ gal	--	0.26 ^J	3.1 ^K	0.26 ^K	0.26 ^K	--	0.25 ^K	--	--	--	--	--	
			-- ton Waste/Wood Bark	--	--	--	--	--	--	--	--	--	--	--	--	--	
2001 Actual Emission Factors		7,910	90,973.00 ton MSW	lbs/hr	28.55 ^A	15.76 ^A	9.94 ^A	1.20 ^A	1.20 ^A	--	0.82 ^A	--	7.0E-02 ^A	5.1E-03 ^A	7.7E-03 ^C	--	
			0.09 x10 ⁶ CF Natural Gas	lb/10 ⁶ scf	0.60 ^E	100 ^F	84 ^F	7.60 ^E	7.60 ^E	--	5.5 ^E	--	5.0E-04 ^E	0.00026 ^L	--	--	
			-- ton Waste/Wood Bark	--	--	--	--	--	--	--	--	--	--	--	--	--	
2002 Actual Emission Factors		8,211	93,107 ton MSW	lbs/hr	16.89 ^A	21.80 ^A	17.32 ^A	4.15 ^A	4.15 ^A	--	0.73 ^A	--	3.6E-02 ^A	5.1E-03 ^A	7.7E-03 ^C	--	
			1.87 x10 ⁶ CF Natural Gas	lb/10 ⁶ scf	0.60 ^E	100 ^F	84 ^F	7.60 ^E	7.60 ^E	--	5.5 ^E	--	5.0E-04 ^E	2.6E-04 ^L	--	--	
			-- ton Waste/Wood Bark	--	--	--	--	--	--	--	--	--	--	--	--	--	
2003 Actual Emission Factors		8,135	95,931 ton MSW	lbs/hr	13.00 ^A	19.88 ^A	29.91 ^A	3.23 ^A	3.23 ^A	--	0.99 ^A	1.50 ^B	3.6E-02 ^A	5.0E-03 ^A	7.7E-03 ^C	55.78 ^D	
			1.66 x10 ⁶ CF Natural Gas	lb/10 ⁶ scf	0.60 ^E	100 ^F	84 ^F	7.60 ^E	7.60 ^E	--	5.5 ^E	--	5.0E-04 ^E	2.6E-04 ^L	--	--	
			-- ton Waste/Wood Bark	--	--	--	--	--	--	--	--	--	--	--	--	--	
2004 Actual Emission Factors		7,758	94,093 ton MSW	lbs/hr	13.00 ^A	19.88 ^A	29.91 ^A	3.23 ^A	3.23 ^A	--	0.99 ^A	1.50 ^B	6.9E-02 ^A	5.0E-03 ^A	7.7E-03 ^C	55.78 ^D	
			1.67 x10 ⁶ CF Natural Gas	lb/10 ⁶ scf	0.60 ^E	100 ^F	84 ^F	7.60 ^E	7.60 ^E	--	5.5 ^E	--	5.0E-04 ^E	2.6E-04 ^L	--	--	
			-- ton Waste/Wood Bark	--	--	--	--	--	--	--	--	--	--	--	--	--	
2005 Actual Emission Factors		7,227	93,242 ton MSW	lbs/hr	13.00 ^A	19.88 ^A	29.91 ^A	3.23 ^A	3.23 ^A	--	0.99 ^A	1.50 ^B	6.9E-02 ^A	5.0E-03 ^A	7.7E-03 ^C	55.78 ^D	
			2.50 x10 ⁶ CF Natural Gas	lb/10 ⁶ scf	0.60 ^E	100 ^F	84 ^F	7.60 ^E	7.60 ^E	--	5.5 ^E	--	5.0E-04 ^E	2.6E-04 ^L	--	--	
			-- ton Waste/Wood Bark	--	--	--	--	--	--	--	--	--	--	--	--	--	
2006 Actual Emission Factors		7,406	89,505 ton MSW	lb/ton	0.19 ^M	2.35 ^M	2.15 ^M	0.14 ^N	0.14 ^N	--	0.046 ^N	0.15 ^B	2.0E-05 ^O	2.5E-05 ^N	1.5E-02 ^C	0.028 ^N	0.0 ^N
			7.00 x10 ⁶ CF Natural Gas	lb/10 ⁶ scf	0.60 ^E	100 ^F	84 ^F	7.60 ^E	7.60 ^E	--	5.5 ^E	--	5.0E-04 ^E	2.6E-04 ^L	--	--	--
			-- ton Waste/Wood Bark	--	--	--	--	--	--	--	--	--	--	--	--	--	--
2007 Actual Emission Factors		6,909	77,780 ton MSW	lb/ton	0.21 ^M	2.80 ^M	1.70 ^M	0.11 ^N	0.11 ^N	--	0.047 ^N	0.13 ^B	1.6E-04 ^O	7.3E-05 ^N	1.2E-03 ^C	0.076 ^N	2.0E-06 ^N
			9.85 x10 ⁶ CF Natural Gas	lb/10 ⁶ scf	0.60 ^E	100 ^F	84 ^F	7.60 ^E	7.60 ^E	--	5.5 ^E	--	5.0E-04 ^E	2.6E-04 ^L	--	--	--
			-- ton Waste/Wood Bark	--	--	--	--	--	--	--	--	--	--	--	--	--	--
2008 Actual Emission Factors		5,416	46,891 ton MSW	lb/ton	0.29 ^M	2.57 ^M	2.35 ^M	0.16 ^N	0.16 ^N	--	0.078 ^N	0.17 ^B	2.5E-04 ^O	8.2E-05 ^N	1.6E-03 ^C	0.16892 ^N	0.0 ^N
			22.24 x10 ⁶ CF Natural Gas	lb/10 ⁶ scf	0.60 ^E	100 ^F	84 ^F	7.60 ^E	7.60 ^E	--	5.5 ^E	--	5.0E-04 ^E	2.6E-04 ^L	--	--	--
			-- ton Waste/Wood Bark	--	--	--	--	--	--	--	--	--	--	--	--	--	--

^A Based on annual compliance stack test. PM₁₀ assumed to be equal to 100-percent PM. Emission factors for 2004 and 2005 used stack test data from 2003.

^B Based on permit limit. Permit No. AC-03-145061.

^C Based on 1999 and 2005 Compliance Test.

^D Based on 1989 Compliance Test.

^E Based on AP-42, Table 1.4-2.

^F Based on AP-42, Table 1.4-1.

^G Based on AP-42, Table 1.3-1. SO₂ is calculated with 142S where S is the sulfur content, 0.5-percent.

^H Based on AP-42, Table 1.3-6.

^I Based on AP-42, Table 1.3-3.

^J Unable to locate source.

^K Based on AP-42, Table 1.5-1. Fourth Edition.

^L Based on AP-42, Table 1.4-4.

^M Based on CEMS data.

^N Based on annual compliance stack test data and annual tons of solid waste burned.

^O Based on permit limit and annual tons of solid waste burned.

Checked by: JB
Reviewed by: DB

**TABLE B-2
ANNUAL (2000-2008) EMISSIONS FROM ANNUAL OPERATING REPORTS FOR THE MWC UNIT NO. 2
BAY COUNTY, PANAMA CITY**

Source Description	EU ID	Annual Operation (hr/yr)	Annual Fuel Usage	Units	Pollutant Emission Factors												
					SO ₂	NO _x	CO	PM	PM ₁₀	PM _{2.5}	VOC	SAM	Lead	Mercury	Fluoride	HCl	Dioxins/Furans
Municipal Waste Combustion Unit 002																	
2000 Actual Emission Factors		8,025	87,966 ton MSW	lbs/hr	16.42 ^A	20.86 ^A	17.54 ^A	3.40 ^A	3.40 ^A	—	3.53 ^A	1.50 ^B	0.028 ^A	0.0037 ^A	0.0073 ^C	55.78 ^D	—
			0.07 x10 ⁶ CF Natural Gas	lb/10 ⁶ scf	0.60 ^E	100 ^F	84 ^F	7.60 ^E	7.60 ^E	—	5.5 ^E	—	5.0E-04 ^E	0.00026 ^L	—	—	—
			3.10 x10 ³ gal Distillate Oil	lb/10 ³ gal	71.00 ^G	20.00 ^G	5.00 ^G	2.00 ^H	1.00 ^H	—	0.20 ^I	—	—	—	—	—	—
			0.07 x10 ³ gal Propane	lb/10 ³ gal	—	0.26 ^J	3.1 ^K	0.26 ^K	0.26 ^K	—	0.25 ^K	—	—	—	—	—	—
			— ton Waste/Wood Bark		—	—	—	—	—	—	—	—	—	—	—	—	—
2001 Actual Emission Factors		7,812	90,973.00 ton MSW	lbs/hr	24.57 ^A	20.42 ^A	12.75 ^A	2.55 ^A	2.55 ^A	—	0.59 ^A	—	4.0E-02 ^A	0.0074 ^A	0.0073 ^C	—	—
			0.08 x10 ⁶ CF Natural Gas	lb/10 ⁶ scf	0.60 ^E	100 ^F	84 ^F	7.60 ^E	7.60 ^E	—	5.5 ^E	—	5.0E-04 ^E	0.00026 ^L	—	—	—
			— ton Waste/Wood Bark		—	—	—	—	—	—	—	—	—	—	—	—	—
2002 Actual Emission Factors		8,026	91,227 ton MSW	lbs/hr	12.70 ^A	22.94 ^A	28.10 ^A	2.10 ^A	2.10 ^A	—	0.55 ^A	—	0.069 ^A	0.00419 ^A	0.0073 ^C	—	—
			1.83 x10 ⁶ CF Natural Gas	lb/10 ⁶ scf	0.60 ^E	100 ^F	84 ^F	7.60 ^E	7.60 ^E	—	5.5 ^E	—	5.0E-04 ^E	2.6E-04 ^L	—	—	—
			— ton Waste/Wood Bark		—	—	—	—	—	—	—	—	—	—	—	—	—
2003 Actual Emission Factors		7,948	95,242 ton MSW	lbs/hr	14.46 ^A	23.64 ^A	43.51 ^A	3.87 ^A	3.87 ^A	—	1.52 ^A	1.50 ^B	4.0E-02 ^A	8.0E-03 ^A	0.0073 ^C	55.78 ^D	—
			1.65 x10 ⁶ CF Natural Gas	lb/10 ⁶ scf	0.60 ^E	100 ^F	84 ^F	7.60 ^E	7.60 ^E	—	5.5 ^E	—	5.0E-04 ^E	0.00026 ^L	—	—	—
			— ton Waste/Wood Bark		—	—	—	—	—	—	—	—	—	—	—	—	—
2004 Actual Emission Factors		7,521	91,129 ton MSW	lbs/hr	14.46 ^A	23.64 ^A	43.51 ^A	3.87 ^A	3.87 ^A	—	1.52 ^A	1.50 ^B	4.0E-02 ^A	8.0E-03 ^A	0.0073 ^C	55.78 ^D	—
			1.62 x10 ⁶ CF Natural Gas	lb/10 ⁶ scf	0.60 ^E	100 ^F	84 ^F	7.60 ^E	7.60 ^E	—	5.5 ^E	—	5.0E-04 ^E	0.00026 ^L	—	—	—
			— ton Waste/Wood Bark		—	—	—	—	—	—	—	—	—	—	—	—	—
2005 Actual Emission Factors		7,147	92,499 ton MSW	lbs/hr	14.46 ^A	23.64 ^A	43.51 ^A	3.87 ^A	3.87 ^A	—	1.52 ^A	1.50 ^B	4.0E-02 ^A	8.0E-03 ^A	0.0073 ^C	55.78 ^D	—
			2.50 x10 ⁶ CF Natural Gas	lb/10 ⁶ scf	0.60 ^E	100 ^F	84 ^F	7.60 ^E	7.60 ^E	—	5.5 ^E	—	5.0E-04 ^E	0.00026 ^L	—	—	—
			— ton Waste/Wood Bark		—	—	—	—	—	—	—	—	—	—	—	—	—
2006 Actual Emission Factors		7,462	88,890 ton MSW	lb/ton	0.14 ^M	3.71 ^M	2.49 ^M	0.07 ^N	0.07 ^N	—	0.036 ^N	0.15 ^B	9.4E-05 ^O	1.7E-05 ^N	1.5E-02 ^C	0.038 ^N	0.0 ^N
			7.00 x10 ⁶ CF Natural Gas	lb/10 ⁶ scf	0.60 ^E	100 ^F	84 ^F	7.60 ^E	7.60 ^E	—	5.5 ^E	—	5.0E-04 ^E	0.00026 ^L	—	—	—
			— ton Waste/Wood Bark		—	—	—	—	—	—	—	—	—	—	—	—	—
2007 Actual Emission Factors		6,576	73,768 ton MSW	lb/ton	0.07 ^M	2.61 ^M	2.22 ^M	0.07 ^N	0.07 ^N	—	0.031 ^N	0.13 ^B	1.6E-04 ^O	4.7E-05 ^N	1.2E-03 ^C	0.058 ^N	0.0E+00 ^N
			9.85 x10 ⁶ CF Natural Gas	lb/10 ⁶ scf	0.60 ^E	100 ^F	84 ^F	7.60 ^E	7.60 ^E	—	5.5 ^E	—	5.0E-04 ^E	0.00026 ^L	—	—	—
			— ton Waste/Wood Bark		—	—	—	—	—	—	—	—	—	—	—	—	—
2008 Actual Emission Factors		5,421	45,158 ton MSW	lb/ton	0.48 ^M	3.19 ^M	2.78 ^M	0.11 ^N	0.11 ^N	—	0.046 ^N	0.18 ^B	4.8E-05 ^O	5.9E-05 ^N	1.7E-03 ^C	0.108341 ^N	0.0 ^N
			22.24 x10 ⁶ CF Natural Gas	lb/10 ⁶ scf	0.60 ^E	100 ^F	84 ^F	7.60 ^E	7.60 ^E	—	5.5 ^E	—	5.0E-04 ^E	0.00026 ^L	—	—	—
			— ton Waste/Wood Bark		—	—	—	—	—	—	—	—	—	—	—	—	—

^A Based on annual compliance stack test. PM₁₀ assumed to be equal to 100-percent PM. Emission factors for 2004 and 2005 used stack test data from 2003.

^B Based on permit limit. Permit No. AC-03-145061.

^C Based on 1999 and 2005 Compliance Test.

^D Based on 1989 Compliance Test.

^E Based on AP-42, Table 1.4-2.

^F Based on AP-42, Table 1.4-1.

^G Based on AP-42, Table 1.3-1. SO₂ is calculated with 142S where S is the sulfur content, 0.5-percent.

^H Based on AP-42, Table 1.3-6.

^I Based on AP-42, Table 1.3-3.

^J Unable to locate source.

^K Based on AP-42, Table 1.5-1. Fourth Edition.

^L Based on AP-42, Table 1.4-4.

^M Based on CEMS data.

^N Based on annual compliance stack test data and annual tons of solid waste burned.

^O Based on permit limit and annual tons of solid waste burned.

APPENDIX C

PERMIT HISTORY FOR THE BAY COUNTY WASTE-TO-ENERGY FACILITY

**APPENDIX C
PERMITTING HISTORY FOR MWC UNIT NOS. 1 AND 2
BAY RESOURCE MANAGEMENT CENTER
BAY COUNTY**

Pollutant	AC 03-145061/ PSD-FL-129	0050031-002-AV	0050031-007-AV	0050031-008-AV	0050031-010-AV		0050031-011-AC		Proposed Limits based on Subpart Cb	
	Dec. 29, 1989	Aug. 1, 2000	Sept. 29, 2001	Jun. 25, 2003	Eff. Nov. 16, 2005	Aug. 1, 2005	Eff. Nov. 16, 2005		Limit	(lb/hr) ^c
	(lb/hr)	(lb/hr)	(lb/hr)	(lb/hr)	Limit	(lb/hr)	Limit	(lb/hr) ^b	Limit	(lb/hr) ^c
Carbon Monoxide (CO)	92.8	92.8	92.8	92.8	250 ppmvd ^a	92.8	250 ppmvd ^a	27.81	250 ppmvd	35.34
Fluorides (F)	0.15	0.15	0.15	0.15	0.15 lb/hr	0.15	0.15 lb/hr	0.15	0.15 lb/hr	0.15
Hydrogen Chloride (HCl)	—	61.7	61.7	61.7	31 ppmvd ^a	—	31 ppmvd ^a	4.49	31 ppmvd	5.34
Mercury (Hg)	0.18	0.18	0.18	0.18	0.070 mg/dscm ^d	0.18	0.070 mg/dscm ^d	6.7E-03	50 ug/dscm	0.00607
Nitrogen Oxides (NO _x)	26.9	26.9	26.9	26.9	170 ppmvd ^a	26.9	170 ppmvd ^a	31.07	210 ppmvd	48.78
Cadmium (Cd)	—	—	—	—	0.040 mg/dscm ^a	—	0.040 mg/dscm ^a	2.3E-03	35 ug/dscm	0.00425
Lead (Pb)	0.10	0.10	0.10	0.10	0.490 mg/dscm ^a	0.10	0.490 mg/dscm ^a	2.8E-02	400 ug/dscm	0.0486
Sulfuric Acid Mist (SAM)	—	1.5	1.5	1.5	1.5 lb/hr	—	1.5 lb/hr	1.5	1.5 lb/hr	1.5
Sulfur Dioxide (SO ₂)	35.8	35.8	35.8	35.8	31 ppmvd ^a	35.8	31 ppmvd ^a	7.89	31 ppmvd	9.38
Particulate Matter (PM)	6.8	6.8	6.8	6.8	27 mg/dscm ^a	6.8	27 mg/dscm ^a	1.52	25 mg/dscm	3.04
Dioxins/Furans (D/F)	—	—	—	—	30 ng/dscm ^a	—	30 ng/dscm ^a	1.7E-06	30 ng/dscm	3.64E-06
Volatile Organic Compounds (VOC)	7.1	7.1	7.1	7.1	7.1 lb/hr	7.1	7.1 lb/hr	7.1	7.1 lb/hr	7.1
Beryllium	5.0E-06	5.0E-06	5.0E-06	5.0E-06	—	—	—	—	—	—

Note:
Permit No. 0050031-006-AC, issued May 30, 2001, did not contain emission limits.
Emission limits represent each unit.

Footnote:
^a Emission limits per 40 CFR 60 Subpart BBBB.
^b Based on gas flow rate of 25,525 dscfm.
^c Based on gas flow rate of 31,087 dscfm.
^d Based on Florida limit in Rule 62-296.416(3)(a)1.

Checked By: DB
Reviewed By: DB



APPENDIX D

ADDITIONAL REFERENCES FOR THE EMISSION FACTORS

Table 1.3-1. CRITERIA POLLUTANT EMISSION FACTORS FOR FUEL OIL COMBUSTION^a

Firing Configuration (SCC) ^a	SO ₂ ^b		SO ₃ ^c		NO _x ^d		CO ^e		Filterable PM ^f	
	Emission Factor (lb/10 ³ gal)	EMISSION FACTOR RATING	Emission Factor (lb/10 ³ gal)	EMISSION FACTOR RATING	Emission Factor (lb/10 ³ gal)	EMISSION FACTOR RATING	Emission Factor (lb/10 ³ gal)	EMISSION FACTOR RATING	Emission Factor (lb/10 ³ gal)	EMISSION FACTOR RATING
Boilers > 100 Million Btu/hr										
No. 6 oil fired, normal firing (1-01-004-01), (1-02-004-01), (1-03-004-01)	157S	A	5.7S	C	47	A	5	A	9.19(S)+3.22	A
No. 6 oil fired, normal firing, low NO _x burner (1-01-004-01), (1-02-004-01)	157S	A	5.7S	C	40	B	5	A	9.19(S)+3.22	A
No. 6 oil fired, tangential firing, (1-01-004-04)	157S	A	5.7S	C	32	A	5	A	9.19(S)+3.22	A
No. 6 oil fired, tangential firing, low NO _x burner (1-01-004-04)	157S	A	5.7S	C	26	E	5	A	9.19(S)+3.22	A
No. 5 oil fired, normal firing (1-01-004-05), (1-02-004-04)	157S	A	5.7S	C	47	B	5	A	10	B
No. 5 oil fired, tangential firing (1-01-004-06)	157S	A	5.7S	C	32	B	5	A	10	B
No. 4 oil fired, normal firing (1-01-005-04), (1-02-005-04)	150S	A	5.7S	C	47	B	5	A	7	B
No. 4 oil fired, tangential firing (1-01-005-05)	150S	A	5.7S	C	32	B	5	A	7	B
No. 2 oil fired (1-01-005-01), (1-02-005-01), (1-03-005-01)	157S	A	5.7S	C	24	D	5	A	2	A
No. 2 oil fired, LNB/FGR, (1-01-005-01), (1-02-005-01), (1-03-005-01)	157S	A	5.7S	A	10	D	5	A	2	A

Table 1.3-1. (cont.)

Firing Configuration (SCC) ^a	SO ₂ ^b		SO _x ^c		NO _x ^d		CO ^e		Filterable PM ^f	
	Emission Factor (lb/10 ³ gal)	EMISSION FACTOR RATING	Emission Factor (lb/10 ³ gal)	EMISSION FACTOR RATING	Emission Factor (lb/10 ³ gal)	EMISSION FACTOR RATING	Emission Factor (lb/10 ³ gal)	EMISSION FACTOR RATING	Emission Factor (lb/10 ³ gal)	EMISSION FACTOR RATING
Boilers < 100 Million Btu/hr										
No. 6 oil fired (1-02-004-02/03) (1-03-004-02/03)	157S	A	2S	A	55	A	5	A	10	B
No. 5 oil fired (1-03-004-04)	157S	A	2S	A	55	A	5	A	9.19(S)+3.22	A
No. 4 oil fired (1-03-005-04)	150S	A	2S	A	20	A	5	A	7	B
Distillate oil fired (1-02-005-02/03) (1-03-005-02/03)	142S	A	2S	A	20	A	5	A	2	A
Residential furnace (A2104004/A2104011)	142S	A	2S	A	18	A	5	A	0.4 ^g	B

^a To convert from lb/10³ gal to kg/10³ L, multiply by 0.120. SCC = Source Classification Code.

^b References 1-2,6-9,14,56-60. S indicates that the weight % of sulfur in the oil should be multiplied by the value given. For example, if the fuel is 1% sulfur, then S = 1.

^c References 1-2,6-8,16,57-60. S indicates that the weight % of sulfur in the oil should be multiplied by the value given. For example, if the fuel is 1% sulfur, then S = 1.

^d References 6-7,15,19,22,56-62. Expressed as NO_x. Test results indicate that at least 95% by weight of NO_x is NO for all boiler types except residential furnaces, where about 75% is NO. For utility vertical fired boilers use 105 lb/10³ gal at full load and normal (>15%) excess air. Nitrogen oxides emissions from residual oil combustion in industrial and commercial boilers are related to fuel nitrogen content, estimated by the following empirical relationship: lb NO_x/10³ gal = 20.54 + 104.39(N), where N is the weight % of nitrogen in the oil. For example, if the fuel is 1% nitrogen, then N = 1.

^e References 6-8,14,17-19,56-61. CO emissions may increase by factors of 10 to 100 if the unit is improperly operated or not well maintained.

^f References 6-8,10,13-15,56-60,62-63. Filterable PM is that particulate collected on or prior to the filter of an EPA Method 5 (or equivalent) sampling train. Particulate emission factors for residual oil combustion are, on average, a function of fuel oil sulfur content where S is the weight % of sulfur in oil. For example, if fuel oil is 1% sulfur, then S = 1.

^g Based on data from new burner designs. Pre-1970's burner designs may emit filterable PM as high as 3.0 lb/10³ gal.

Table 1.3-3. EMISSION FACTORS FOR TOTAL ORGANIC COMPOUNDS (TOC), METHANE, AND NONMETHANE TOC (NMTOC) FROM UNCONTROLLED FUEL OIL COMBUSTION^a

EMISSION FACTOR RATING: A

Firing Configuration (SCC)	TOC ^b Emission Factor (lb/10 ³ gal)	Methane ^b Emission Factor (lb/10 ³ gal)	NMTOC ^b Emission Factor (lb/10 ³ gal)
Utility boilers			
No. 6 oil fired, normal firing (1-01-004-01)	1.04	0.28	0.76
No. 6 oil fired, tangential firing (1-01-004-04)	1.04	0.28	0.76
No. 5 oil fired, normal firing (1-01-004-05)	1.04	0.28	0.76
No. 5 oil fired, tangential firing (1-01-004-06)	1.04	0.28	0.76
No. 4 oil fired, normal firing (1-01-005-04)	1.04	0.28	0.76
No. 4 oil fired, tangential firing (1-01-005-05)	1.04	0.28	0.76
Industrial boilers			
No. 6 oil fired (1-02-004-01/02/03)	1.28	1.00	0.28
No. 5 oil fired (1-02-004-04)	1.28	1.00	0.28
Distillate oil fired (1-02-005-01/02/03)	0.252	0.052	0.2
No. 4 oil fired (1-02-005-04)	0.252	0.052	0.2
Commercial/institutional/residential combustors			
No. 6 oil fired (1-03-004-01/02/03)	1.605	0.475	1.13
No. 5 oil fired (1-03-004-04)	1.605	0.475	1.13
Distillate oil fired (1-03-005-01/02/03)	0.556	0.216	0.34
No. 4 oil fired (1-03-005-04)	0.556	0.216	0.34
Residential furnace (A2104004/A2104011)	2.493	1.78	0.713

^a To convert from lb/10³ gal to kg/10³ L, multiply by 0.12. SCC = Source Classification Code.

^b References 29-32. Volatile organic compound emissions can increase by several orders of magnitude if the boiler is improperly operated or is not well maintained.

Table 1.3-6. CUMULATIVE PARTICLE SIZE DISTRIBUTION AND SIZE-SPECIFIC EMISSION FACTORS FOR UNCONTROLLED INDUSTRIAL BOILERS FIRING DISTILLATE OIL^a

EMISSION FACTOR RATING: E

Particle Size ^b (μm)	Cumulative Mass % ≤ Stated Size	Cumulative Emission Factor (lb/10 ³ gal)
15	68	1.33
10	50	1.00
6	30	0.58
2.5	12	0.25
1.25	9	0.17
1.00	8	0.17
0.625	2	0.04
TOTAL	100	2.00

^a Reference 26. Source Classification Codes 1-02-005-01/02/03. To convert from lb/10³ gal to kg/10³ L, multiply by 0.12.

^b Expressed as aerodynamic equivalent diameter.

Table 1.3-7. CUMULATIVE PARTICLE SIZE DISTRIBUTION AND SIZE-SPECIFIC EMISSION FACTORS UNCONTROLLED COMMERCIAL BOILERS BURNING RESIDUAL OR DISTILLATE OIL^a

EMISSION FACTOR RATING: D

Particle Size ^b (μm)	Cumulative Mass % ≤ Stated Size		Cumulative Emission Factor ^c (lb/10 ³ gal)	
	Residual Oil	Distillate Oil	Residual Oil	Distillate Oil
15	78	60	6.50A	1.17
10	62	55	5.17A	1.08
6	44	49	3.67A	1.00
2.5	23	42	1.92A	0.83
1.25	16	38	1.33A	0.75
1.00	14	37	1.17A	0.75
0.625	13	35	1.08A	0.67
TOTAL	100	100	8.34A	2.00

^a Reference 26. Source Classification Codes: 1-03-004-01/02/03/04 and 1-03-005-01/02/03/04. To convert from lb/10³ gal to kg/10³ L, multiply by 0.12.

^b Expressed as aerodynamic equivalent diameter.

^c Particulate emission factors for residual oil combustion without emission controls are, on average, a function of fuel oil grade and sulfur content where S is the weight % of sulfur in the fuel. For example, if the fuel is 1.0% sulfur, then S = 1.

No. 6 oil: A = 1.12(S) + 0.37

No. 5 oil: A = 1.2

No. 4 oil: A = 0.84

No. 2 oil: A = 0.24

Table 1.3-11. EMISSION FACTORS FOR METALS FROM UNCONTROLLED NO. 6 FUEL OIL COMBUSTION^a

Metal	Average Emission Factor ^{b,d} (lb/10 ³ Gal)	EMISSION FACTOR RATING
Antimony	5.25E-03 ^c	E
Arsenic	1.32E-03	C
Barium	2.57E-03	D
Beryllium	2.78E-05	C
Cadmium	3.98E-04	C
Chloride	3.47E-01	D
Chromium	8.45E-04	C
Chromium VI	2.48E-04	C
Cobalt	6.02E-03	D
Copper	1.76E-03	C
Fluoride	3.73E-02	D
Lead	1.51E-03	C
Manganese	3.00E-03	C
Mercury	1.13E-04	C
Molybdenum	7.87E-04	D
Nickel	8.45E-02	C
Phosphorous	9.46E-03	D
Selenium	6.83E-04	C
Vanadium	3.18E-02	D
Zinc	2.91E-02	D

^a Data are for residual oil fired boilers, Source Classification Codes (SCCs) 1-01-004-01/04.

^b References 64-72. 18 of 19 sources were uncontrolled and 1 source was controlled with low efficiency ESP. To convert from lb/10³ gal to kg/10³ L, multiply by 0.12.

^c References 29-32,40-44.

^d For oil/water mixture, reduce factors in proportion to water content of the fuel (due to dilution). To adjust the listed values for water content, multiply the listed value by 1-decimal fraction of water (ex: For fuel with 9 percent water by volume, multiply by 1-0.9=.91).

Table 1.4-1. EMISSION FACTORS FOR NITROGEN OXIDES (NO_x) AND CARBON MONOXIDE (CO)
FROM NATURAL GAS COMBUSTION^a

Combustor Type (MMBtu/hr Heat Input) [SCC]	NO _x ^b		CO	
	Emission Factor (lb/10 ⁶ scf)	Emission Factor Rating	Emission Factor (lb/10 ⁶ scf)	Emission Factor Rating
Large Wall-Fired Boilers (>100) [1-01-006-01, 1-02-006-01, 1-03-006-01]				
Uncontrolled (Pre-NSPS) ^c	280	A	84	B
Uncontrolled (Post-NSPS) ^c	190	A	84	B
Controlled - Low NO _x burners	140	A	84	B
Controlled - Flue gas recirculation	100	D	84	B
Small Boilers (<100) [1-01-006-02, 1-02-006-02, 1-03-006-02, 1-03-006-03]				
Uncontrolled	100	B	84	B
Controlled - Low NO _x burners	50	D	84	B
Controlled - Low NO _x burners/Flue gas recirculation	32	C	84	B
Tangential-Fired Boilers (All Sizes) [1-01-006-04]				
Uncontrolled	170	A	24	C
Controlled - Flue gas recirculation	76	D	98	D
Residential Furnaces (<0.3) [No SCC]				
Uncontrolled	94	B	40	B

^a Reference 11. Units are in pounds of pollutant per million standard cubic feet of natural gas fired. To convert from lb/10⁶ scf to kg/10⁶ m³, multiply by 16. Emission factors are based on an average natural gas higher heating value of 1,020 Btu/scf. To convert from lb/10⁶ scf to lb/MMBtu, divide by 1,020. The emission factors in this table may be converted to other natural gas heating values by multiplying the given emission factor by the ratio of the specified heating value to this average heating value. SCC = Source Classification Code. ND = no data. NA = not applicable.

^b Expressed as NO_x. For large and small wall fired boilers with SNCR control, apply a 24 percent reduction to the appropriate NO_x emission factor. For tangential-fired boilers with SNCR control, apply a 13 percent reduction to the appropriate NO_x emission factor.

^c NSPS=New Source Performance Standard as defined in 40 CFR 60 Subparts D and Db. Post-NSPS units are boilers with greater than 250 MMBtu/hr of heat input that commenced construction modification, or reconstruction after August 17, 1971, and units with heat input capacities between 100 and 250 MMBtu/hr that commenced construction modification, or reconstruction after June 19, 1984.

TABLE 1.4-2. EMISSION FACTORS FOR CRITERIA POLLUTANTS AND GREENHOUSE GASES FROM NATURAL GAS COMBUSTION^a

Pollutant	Emission Factor (lb/10 ⁶ scf)	Emission Factor Rating
CO ₂ ^b	120,000	A
Lead	0.0005	D
N ₂ O (Uncontrolled)	2.2	E
N ₂ O (Controlled-low-NO _x burner)	0.64	E
PM (Total) ^c	7.6	D
PM (Condensable) ^c	5.7	D
PM (Filterable) ^c	1.9	B
SO ₂ ^d	0.6	A
TOC	11	B
Methane	2.3	B
VOC	5.5	C

^a Reference 11. Units are in pounds of pollutant per million standard cubic feet of natural gas fired. Data are for all natural gas combustion sources. To convert from lb/10⁶ scf to kg/10⁶ m³, multiply by 16. To convert from lb/10⁶ scf to lb/MMBtu, divide by 1,020. The emission factors in this table may be converted to other natural gas heating values by multiplying the given emission factor by the ratio of the specified heating value to this average heating value. TOC = Total Organic Compounds. VOC = Volatile Organic Compounds.

^b Based on approximately 100% conversion of fuel carbon to CO₂. CO₂[lb/10⁶ scf] = (3.67) (CON) (C)(D), where CON = fractional conversion of fuel carbon to CO₂, C = carbon content of fuel by weight (0.76), and D = density of fuel, 4.2x10⁴ lb/10⁶ scf.

^c All PM (total, condensable, and filterable) is assumed to be less than 1.0 micrometer in diameter. Therefore, the PM emission factors presented here may be used to estimate PM₁₀, PM_{2.5} or PM₁ emissions. Total PM is the sum of the filterable PM and condensable PM. Condensable PM is the particulate matter collected using EPA Method 202 (or equivalent). Filterable PM is the particulate matter collected on, or prior to, the filter of an EPA Method 5 (or equivalent) sampling train.

^d Based on 100% conversion of fuel sulfur to SO₂. Assumes sulfur content is natural gas of 2,000 grains/10⁶ scf. The SO₂ emission factor in this table can be converted to other natural gas sulfur contents by multiplying the SO₂ emission factor by the ratio of the site-specific sulfur content (grains/10⁶ scf) to 2,000 grains/10⁶ scf.

TABLE 1.4-4. EMISSION FACTORS FOR METALS FROM NATURAL GAS COMBUSTION^a

CAS No.	Pollutant	Emission Factor (lb/10 ⁶ scf)	Emission Factor Rating
7440-38-2	Arsenic ^b	2.0E-04	E
7440-39-3	Barium	4.4E-03	D
7440-41-7	Beryllium ^b	<1.2E-05	E
7440-43-9	Cadmium ^b	1.1E-03	D
7440-47-3	Chromium ^b	1.4E-03	D
7440-48-4	Cobalt ^b	8.4E-05	D
7440-50-8	Copper	8.5E-04	C
7439-96-5	Manganese ^b	3.8E-04	D
7439-97-6	Mercury ^b	2.6E-04	D
7439-98-7	Molybdenum	1.1E-03	D
7440-02-0	Nickel ^b	2.1E-03	C
7782-49-2	Selenium ^b	<2.4E-05	E
7440-62-2	Vanadium	2.3E-03	D
7440-66-6	Zinc	2.9E-02	E

^a Reference 11. Units are in pounds of pollutant per million standard cubic feet of natural gas fired. Data are for all natural gas combustion sources. Emission factors preceded by a less-than symbol are based on method detection limits. To convert from lb/10⁶ scf to kg/10⁶ m³, multiply by 16. To convert from lb/10⁶ scf to lb/MMBtu, divide by 1,020.

^b Hazardous Air Pollutant as defined by Section 112(b) of the Clean Air Act.

Table 1.5-1. EMISSION FACTORS FOR LPG COMBUSTION^a

EMISSION FACTOR RATING: E

Pollutant	Butane Emission Factor (lb/10 ³ gal)		Propane Emission Factor (lb/10 ³ gal)	
	Industrial Boilers ^b (SCC 1-02-010-01)	Commercial Boilers ^c (SCC 1-03-010-01)	Industrial Boilers ^b (SCC 1-02-010-02)	Commercial Boilers ^c (SCC 1-03-010-02)
PM, Filterable ^d	0.2	0.2	0.2	0.2
PM, Condensable	0.6	0.6	0.5	0.5
PM, Total	0.8	0.8	0.7	0.7
SO ₂ ^e	0.09S	0.09S	0.10S	0.10S
NO _x ^f	15	15	13	13
N ₂ O ^g	0.9	0.9	0.9	0.9
CO ₂ ^h	14,300	14,300	12,500	12,500
CO	8.4	8.4	7.5	7.5
TOC	1.1	1.1	1.0	1.0
CH ₄ ⁱ	0.2	0.2	0.2	0.2

^a Assumes PM, CO, and TOC emissions are the same, on a heat input basis, as for natural gas combustion. Use heat contents of 91.5 x 10⁶ Btu/10³ gallon for propane, 102 x 10⁶ Btu/10³ gallon for butane, 1020 x 10⁶ Btu/10⁶ scf for methane when calculating an equivalent heat input basis. For example, the equation for converting from methane's emissions factors to propane's emissions factors is as follows: lb pollutant/10³ gallons of propane = (lb pollutant/10⁶ ft³ methane) * (91.5 x 10⁶ Btu/10³ gallons of propane) / (1020 x 10⁶ Btu/10⁶ scf of methane). The NO_x emission factors have been multiplied by a correction factor of 1.5, which is the approximate ratio of propane/butane NO_x emissions to natural gas NO_x emissions. To convert from lb/10³ gal to kg/10³ L, multiply by 0.12. SCC = Source Classification Code.

^b Heat input capacities generally between 10 and 100 million Btu/hour.

^c Heat input capacities generally between 0.3 and 10 million Btu/hour.

^d Filterable particulate matter (PM) is that PM collected on or prior to the filter of an EPA Method 5 (or equivalent) sampling train. For natural gas, a fuel with similar combustion characteristics, all PM is less than 10 μm in aerodynamic equivalent diameter (PM-10).

^e S equals the sulfur content expressed in gr/100 ft³ gas vapor. For example, if the butane sulfur content is 0.18 gr/100 ft³, the emission factor would be (0.09 x 0.18) = 0.016 lb of SO₂/10³ gal butane burned.

^f Expressed as NO₂.

^g Reference 12.

^h Assuming 99.5% conversion of fuel carbon to CO₂.

ⁱ EMISSION FACTOR RATING = C.

^k Reference 13.