



Florida Department of Environmental Protection

Bob Martinez Center
2600 Blair Stone Road
Tallahassee, Florida 32399-2400

Charlie Crist
Governor

Jeff Kottkamp
Lt. Governor

Michael W. Sole
Secretary

October 10, 2008

Mr. Victor Lohman
General Manager
Lohman Pet Cemetery And
Cremation, Incorporated
Pet Crematory
1425 Bellevue Avenue
Daytona Beach, Florida 32114

Dear Mr. Lohman:

This is to acknowledge that your notification of intent to use the authority of Rule 62-210.310 to operate your facility was received on September 8, 2008. We have assigned ARMS No. 1270069-005 to this facility.

As you know, pursuant to Florida Statutes section 403.814, authority to operate under general permits commences thirty (30) days after receipt of the registration form unless you have been notified by this office that your facility has not shown entitlement to operate pursuant to the rule provisions.

For your information, authority to operate pursuant to Rule 62-210.310 expires after five (5) years. Therefore, a new registration form must be received no later than five (5) years after the date your notice was received as indicated above. If your general permit rule conditions require testing, such testing must be completed within the time frame specified in the rule.

If you have any additional questions, please contact Dickson Dibble at 850/921-9586.

Sincerely,

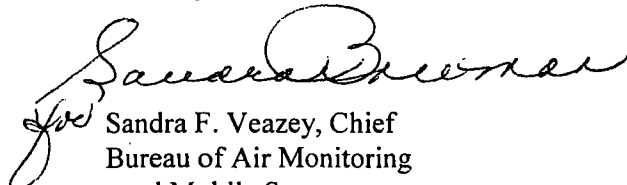
Sandra F. Veazey, Chief
Bureau of Air Monitoring
and Mobile Sources

SFV/pg

cc: Ms. Caroline Shine, Central District

**ANIMAL CREMATORY
AIR GENERAL PERMIT REGISTRATION FORM**

RECEIVED
SEP 10 2008
Bureau of Air, Water,
& Mobile Source
Control

Part II. Notification to Permitting Office
(Detach and submit to appropriate permitting office; keep copy onsite)

Instructions: To give notice to the Department of an eligible facility's intent to use this air general permit, the owner or operator of the facility must detach and complete this part of the Air General Permit Registration Form and submit it to the appropriate Department of Environmental Protection or local air pollution control program office which has permitting authority. Please type or print clearly all information, and enclose the appropriate air general permit registration processing fee pursuant to Rule 62-4.050(4)(o), F.A.C. (\$100 as of the effective date of this form)

1270069-005

Registration Type

Check one:

INITIAL REGISTRATION - Notification of intent to:

- Construct and operate a proposed new facility.
- Operate an existing facility not currently using an air general permit (e.g., a facility proposing to go from an air operation permit to an air general permit).

RE-REGISTRATION (for facilities currently using an air general permit) - Notification of intent to:

- Continue operating the facility after expiration of the current term of air general permit use.
- Continue operating the facility after a change of ownership.
- Make an equipment change requiring re-registration pursuant to Rule 62-210.310(2)(e), F.A.C., or any other change not considered an administrative correction under Rule 62-210.310(2)(d), F.A.C.

Surrender of Existing Air Operation Permit(s) - For Initial Registrations Only

If the facility currently holds one or more air operation permits, such permit(s) must be surrendered by the owner or operator upon the effective date of this air general permit. In such case, check the first box, and indicate the operation permits being surrendered. If no air operation permits are held by the facility, check the second box.

- All existing air operation permits for this facility are hereby surrendered upon the effective date of this air general permit; specifically permit number(s): _____
- No air operation permits currently exist for this facility.

General Facility Information

Facility Owner/Company Name (Name of corporation, agency, or individual owner who or which owns, leases, operates, controls, or supervises the facility.)

Lohman Pet Cemetery + Cremation, Inc.

Site Name (Name, if any, of the facility site; e.g., Plant A, Metropolis Plant, etc. If more than one facility is owned, a registration form must be completed for each.) *Pet Crematory*

*1432 Bellevue Ave.
Daytona Beach, FL 32114*

Facility Location (Provide the physical location of the facility, not necessarily the mailing address.)

Street Address: *1425 Bellevue Ave.*

City: *Daytona Beach* County: *Volusia* Zip Code: *32114*

Facility Start-Up Date (Estimated start-up date of proposed new facility.) (N/A for existing facilities)

Early 2008 *Sept 15, 2008*

1425

Owner/Authorized Representative

Name and Position Title: (Person who, by signing this form below, certifies that the facility is eligible to use this air general permit.)

Print Name and Title: *Nancy Lohman, Vice President*

Owner/Authorized Representative Mailing Address

Organization/Firm: *Lohman Offices*
Street Address: *725 W. Granada Blvd, Ste 48*
City: *Ormond Beach* County: *Volusia* Zip Code: *32174*

Owner/Authorized Representative Telephone Numbers

Telephone: *386.615.1170* Fax: *386.615.0070*
Cell phone (optional): *386.451.2011*

Facility Contact (If different from Owner/Authorized Representative)

Name and Position Title (Plant manager or person to be contacted regarding day-to-day operations at the facility.)

Print Name and Title: *Victor Lohman, General Mgr.*

Facility Contact Mailing Address

Organization/Firm: *Lohman Pet Cemetery + Cremation Services*
Street Address: *1425 Bellevue Ave.*
City: *Daytona Beach* County: *Volusia* Zip Code: *32114*

Facility Contact Telephone Numbers

Telephone: *386.226-1100* Fax: *386.226-1101*
Cell phone (optional): *386.295-0200*

Owner/Authorized Representative Statement

This statement must be signed and dated by the person named above as owner or authorized representative

I, the undersigned, am the owner or authorized representative of the owner or operator of the facility addressed in this Air General Permit Registration Form. I hereby certify, based on information and belief formed after reasonable inquiry, that the facility addressed in this registration form is eligible for use of this air general permit and that the statements made in this registration form are true, accurate and complete. Further, I agree to operate and maintain the facility described in this registration form so as to comply with all applicable standards for control of air pollutant emissions found in the statutes of the State of Florida and rules of the Department of Environmental Protection and revisions thereof.

I will promptly notify the Department of any changes to the information contained in this registration form.

Nancy Lohman
Signature

9-3-08
Date

Design Calculations

If this is an initial registration for a proposed new animal crematory unit, provide design calculations to confirm a sufficient volume in the secondary chamber combustion zone to provide for at least a 1.0 second gas residence time at 1800 degrees F.

- Manufacturer's' design calculations attached.
- Registration is not for proposed new animal crematory unit(s).

Description of Facility

Below, or as an attachment to this form, provide a description of all crematory operations at the facility in sufficient detail to demonstrate the facility's eligibility for use of this air general permit and to provide a basis for tracking any future equipment or process changes at the facility. Describe all air pollutant-emitting processes and equipment at the facility, and identify any air pollution control measures or equipment used.

See attached process flow diagram

PLOT PLAN

NORTH



SHOW ALL SURROUNDING BUILDINGS
AND ROADS WITHIN 250 FEET
OF THE EQUIPMENT COVERED
BY THIS APPLICATION.

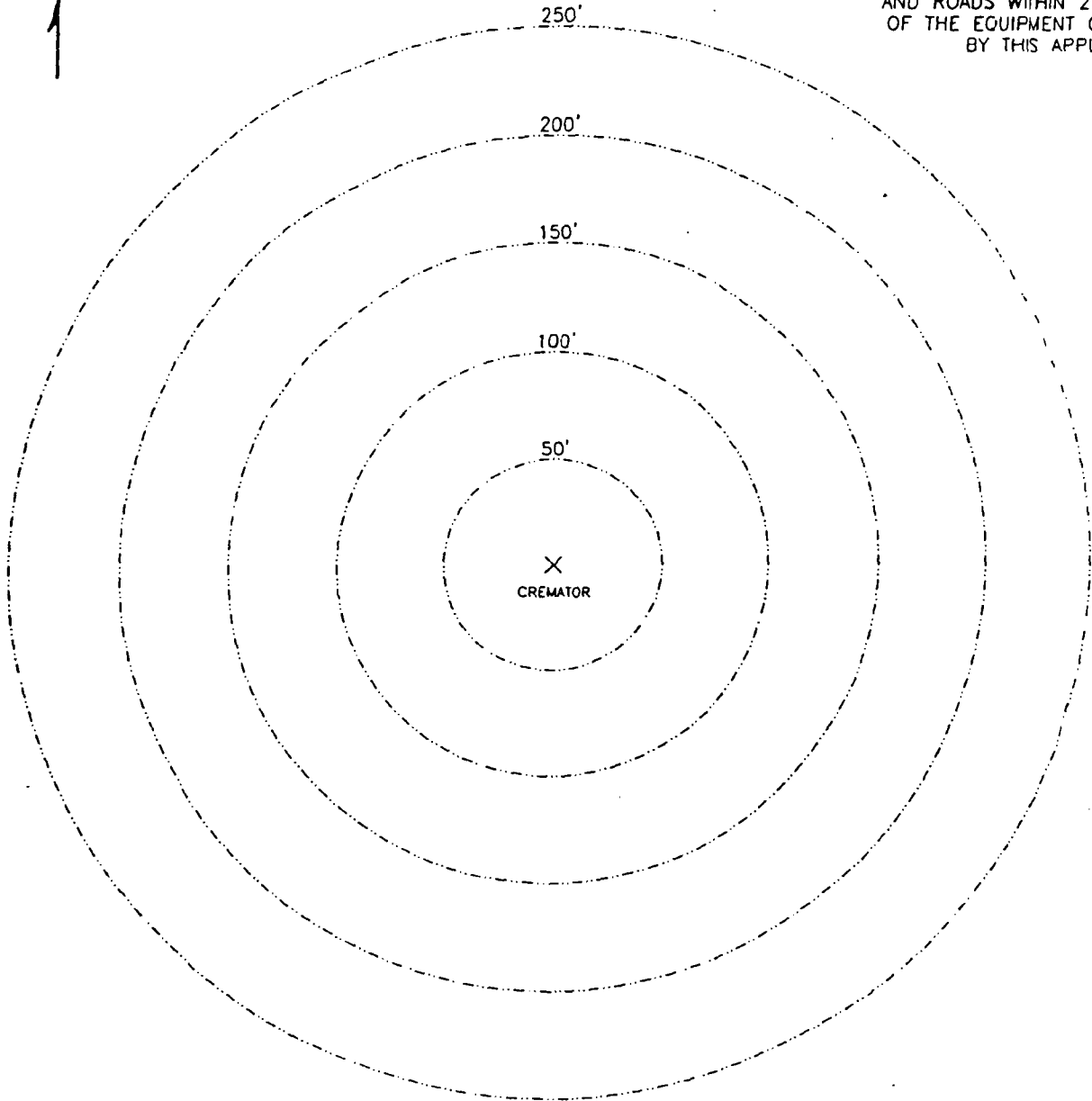

STRUCTURE DESCRIPTION

INSTRUCTIONS

1. INDICATE LOCATION AND TYPE OF BUILDING BY THE USE OF SMALL NUMBERED CIRCLES WITH THE DESCRIPTION BELOW.
2. SHOW ROADS AS LINES REPRESENTING THE ROAD EDGES. INDICATE STREET NAMES AND HIGHWAY NUMBERS.
3. SHOW WOODED OR CLEARED AREA BY APPROXIMATE BOUNDARY LINES AND THE WORDS "WOODS," "CLEARED," "CORNFIELD," ETC.

- (1)
- (2)
- (3)
- (4)
- (5)
- (6)
- (7)
- (8)
- (9)
- (10)

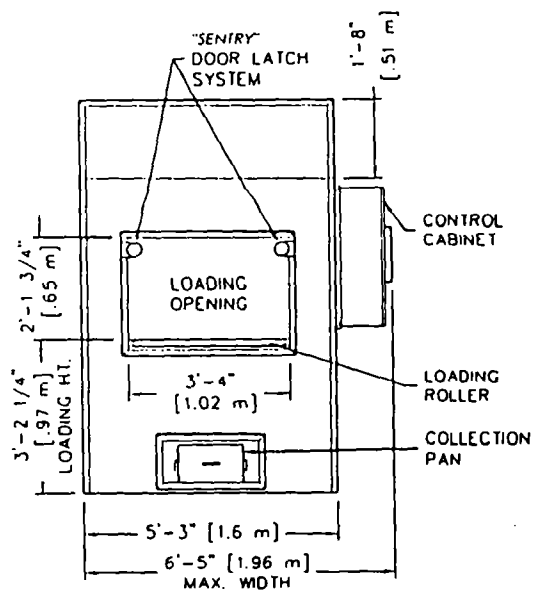

FRONT
ELEVATION

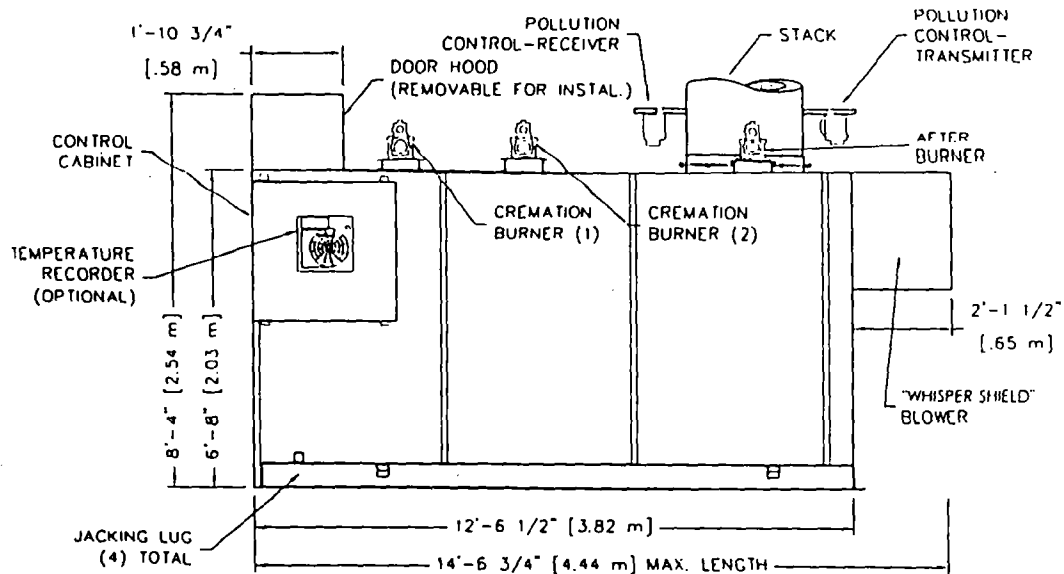

RIGHT SIDE
ELEVATION

NOTES:

- 1) CONTROL CABINET MOUNTS ON UNIT'S LEFT OR RIGHT SIDES, OR REMOTELY.
- 2) CHAMBER WIDTH IS 39" [0.99m]

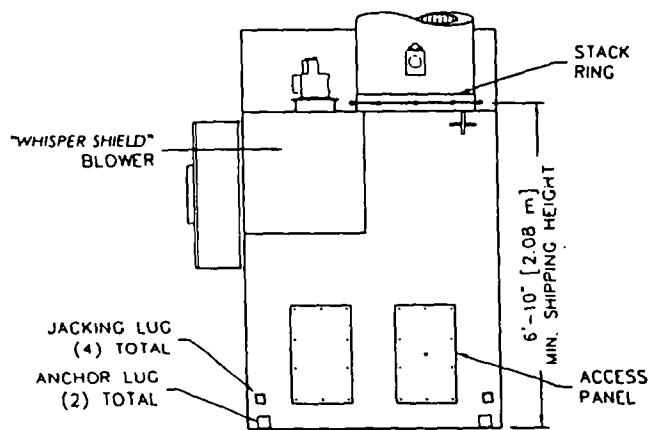

REAR
ELEVATION

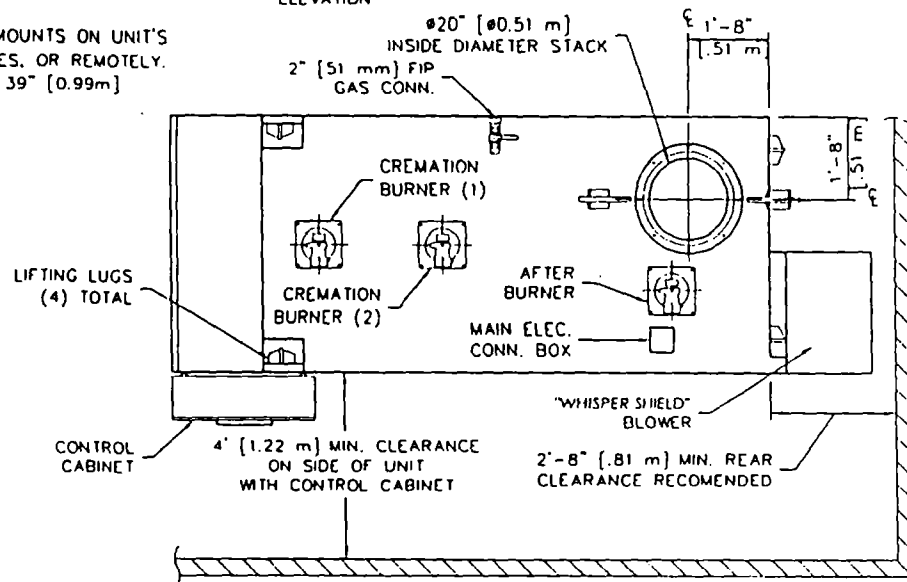

PLAN
VIEW



2045 Sprint Boulevard
Apopka, Florida 32703
USA

POWER-PAK II (PET)

PLAN & ELEVATIONS INCL: CLEARANCES,
REQUIREMENTS & RECOMENDATIONS

DATE:	10-26-06	SCALE:	1/4"=1'
DRAWN:	JG	PLOT SCALE:	1:48
APRVD:		SHEET:	1 OF: 1
DWG FILE:	PP11-Pet-MarketingPlanElevS1R2		
DWG #:	0000139		

LEGEND OF SYMBOLS

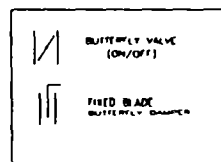

FLOW DIAGRAM

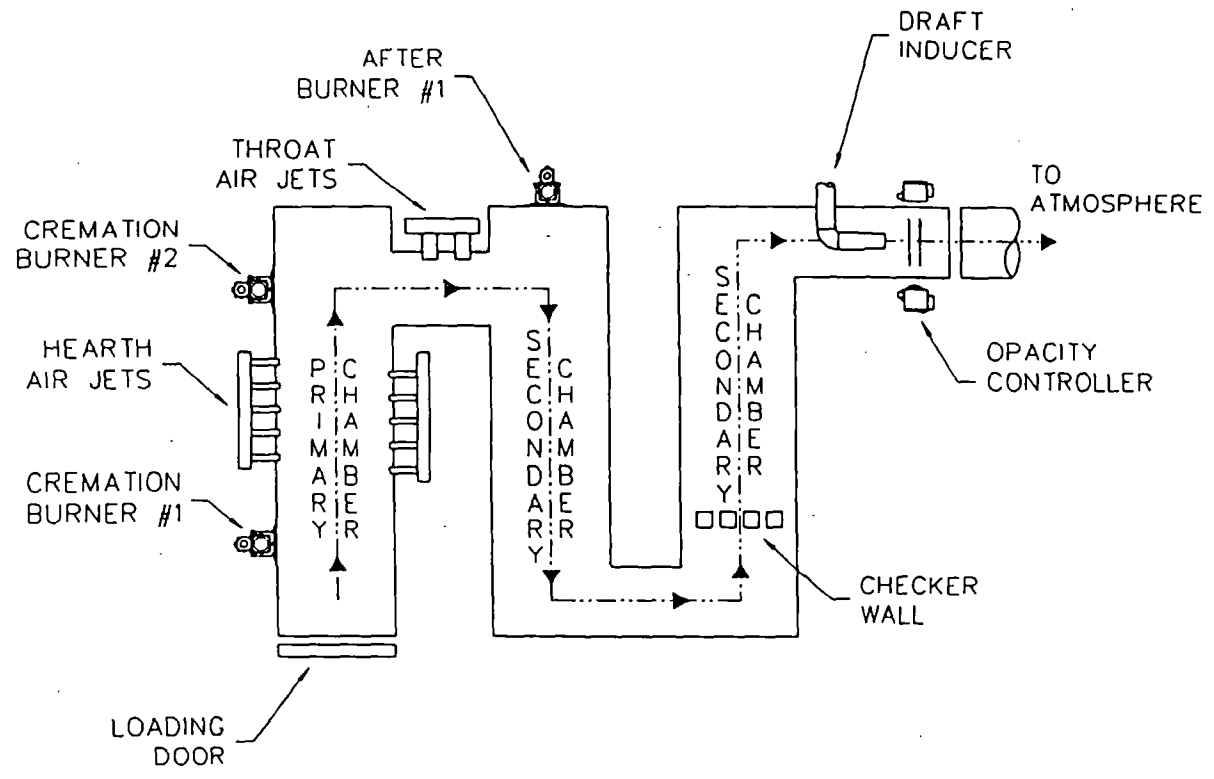

AIR SCHEMATIC

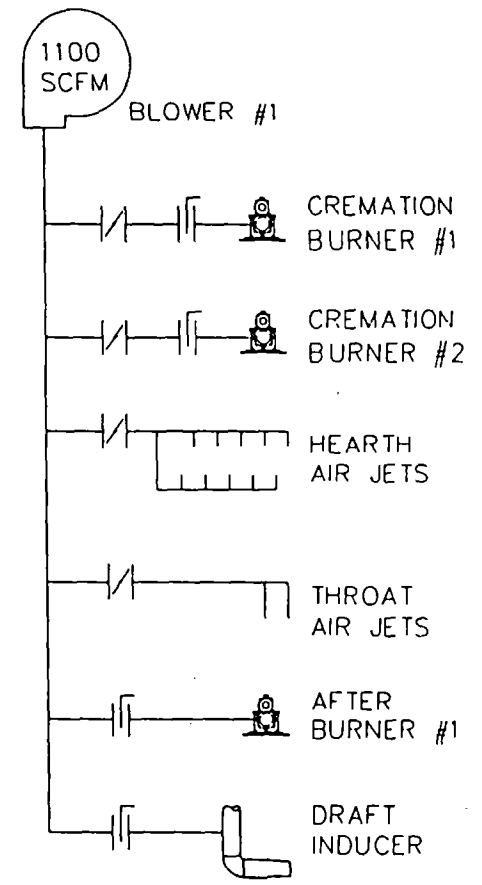

Matthews
CREMATION DIVISION

2045 Sprint Boulevard
Apopka, Florida 32703
USA

POWER PAK II Pet

FLOW DIAGRAM
& AIR SCHEMATIC

DATE:	08-05-05	SCALE:	1/4"=1'
DRAWN:	JG	PLOT SCALE:	1:48
APRVD:		SHEET:	1 OF 1
DWG FILE:	PPII-PetFlowDiaAirSchem		
DWG #:	0000644		

CREMATOR CLEARANCES

RECOMMENDED MINIMUM

TOP: ②	2 FEET [610 mm]	6 INCHES [152 mm]
CABINET SIDE:	4 FEET [1.22 m]	4 FEET [1.22 m]
OTHER SIDE:	2 FEET [610 mm]	6 INCHES [152 mm]
FRONT:	9 FEET [2.74 m]	8 FEET [2.44 m]
REAR:	3 FEET [0.91 m]	32 INCHES [812 mm]
STACK:	6 INCHES [152 mm]	6 INCHES [152 mm]

- FOR CLEARANCES OTHER THAN THOSE SHOWN, OR FOR SPECIAL REQUIREMENTS, CONSULT YOUR MCD REP.
- FROM HIGHEST POINT ON UNIT.
- CONTROL CABINET MOUNTS ON UNIT'S LEFT OR RIGHT SIDES, OR REMOTELY. (SEE PLAN VIEW, SHEET 1).
- REAR OF UNIT REFERS TO THE "BACK PLATE". RATHER THAN THE BACK OF THE "WHISPER SHIELD" (SEE PLAN VIEW, SHEET 1).

CREMATOR REQUIREMENTS

FUEL: A PRESSURE REGULATOR ADJUSTABLE TO 7" [178 mm] W.C. FOR NATURAL GAS, OR 11" [279 mm] W.C. FOR LP GAS.

CAPACITY: RANGES FROM 2.0 TO 4.0 MILLION BTU/HR [2.1 TO 3.1 MILLION KILOJOULES/HR] DEPENDING UPON AMOUNT OF BURNERS.

ELECTRICAL: 230 VOLT, 3ø, (40A BREAKER) AND 115v (10A BREAKER), OR 230 VOLT, 1ø, (70A BREAKER) AND 115v (10A BREAKER) 50/60 HERTZ

AIR: LOUVER NEAR THE REAR OF THE UNIT CAPABLE OF PASSING 2,500 CU FT/MIN [70.8 CU M/MIN] OF FREE AIR (36" X 36") [914 mm X 914 mm]

STACK INSTALLATION INSTRUCTIONS

- APPLY A 1/2" THICK MORTAR JOINT TO EXPOSED REFRACTORY SURFACE IN STACK RING. LOWER THE BASE STACK SECTION (B) ONTO STACK RING (A) AND FASTEN WITH HARDWARE PROVIDED (NO MORE THAN (2) STACK SECTIONS SHALL BE LIFTED TOGETHER). REPEAT PROCESS FOR REMAINING STACK SECTIONS. IF SECTIONS OF VARYING LENGTHS ARE SUPPLIED, ASSEMBLE AS TO AVOID FLANGES & LIFTING EYES INTERFERING WITH RAIN COLLAR LOCATION.
- INSTALL STORM COLLAR ON STACK, 3" [72 mm] ABOVE NON-COMBUSTIBLE LINER (FLASHING), ALLOWING FOR PROPER VENTILATION (SEE DETAIL).
- APPLY A 1/4" [6 mm] BEAD OF HIGH-TEMPERATURE SILICON SEALANT (PROVIDED BY MCD) TO THE JOINT BETWEEN THE STORM COLLAR (C) AND THE STACK (B).
- STORM COLLAR IS FURNISHED BY MCD. THE NON-COMBUSTIBLE LINER (FLASHING) TO BE PROVIDED BY THE OTHERS.
- IF FIFTY PERCENT OF THE STACK LENGTH IS ABOVE THE ROOF, GUY WIRES MAY BE REQUIRED. CONSULT WITH YOUR MCD REP.
- RAIN CAP NOT REQUIRED.

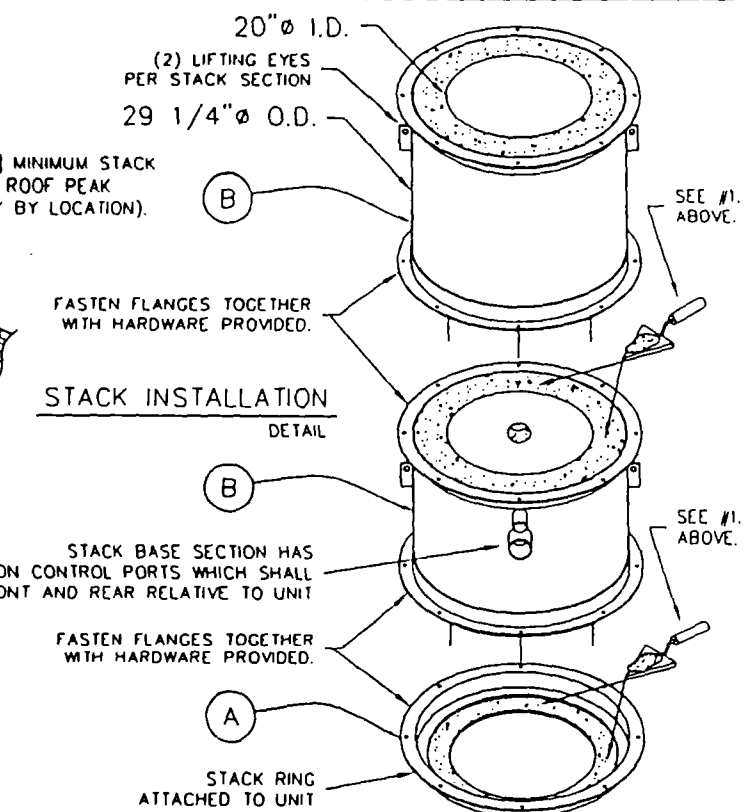
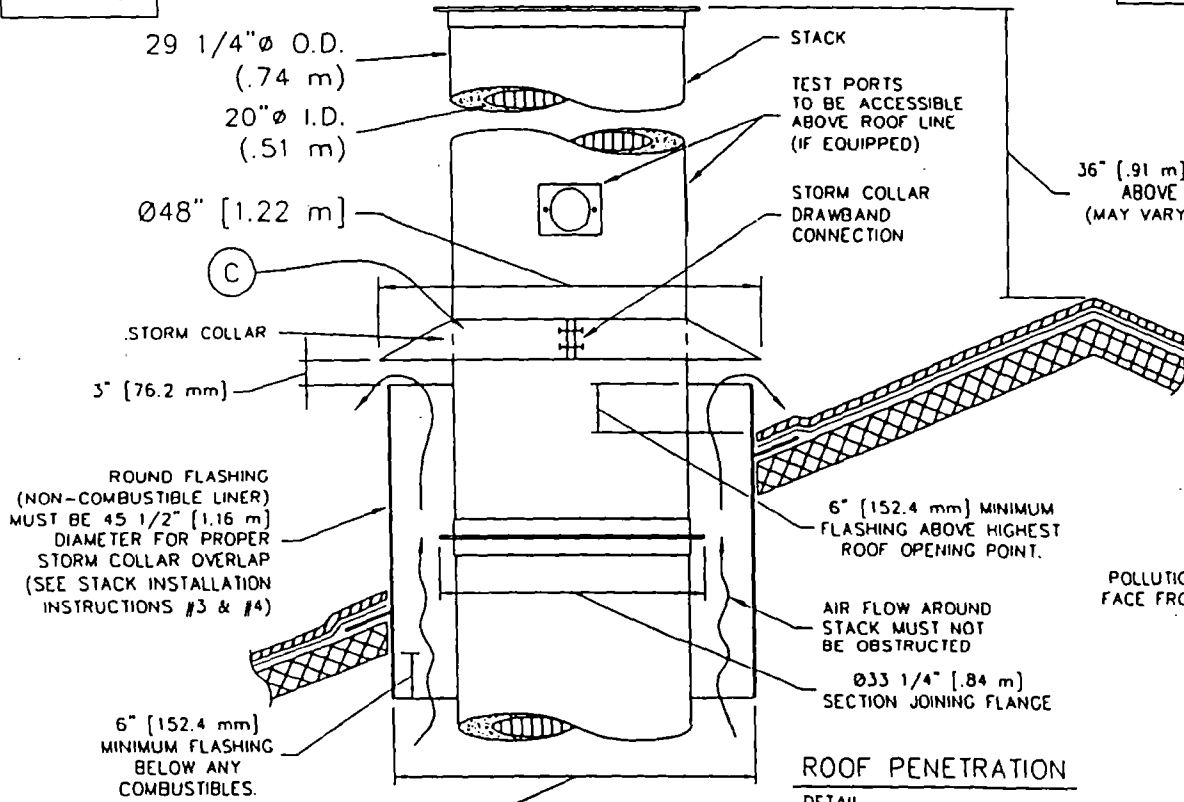

Ø45 1/2" [1.16 m] REQUIRED FOR PROPER STACK CLEARANCE.

Matthews
CALMATION DIVISION

2045 Sprint Boulevard
Apopka, Florida 32703
USA

POWER-PAK II (PET)

STACK DETAILS, CLEARANCES & INSTALLATION INSTRUCTIONS.
REFRACTORY STACK DETAIL

DATE:	10-26-06	SCALE:	1/2"=1'
DRAWN:	JG	PLOT SCALE:	1:24
APRVD:		SHEET:	2 OF 2
DWG FILE:	PPII-Pet-MarketingStockRefS2R4		
DWG #:	0000139		

SPECIFICATIONS- Power-Pak II Pet

1. Equipment Type Matthews Cremation Division; Power-Pak II
 - A. Model No. IE43-PPII
 - B. Underwriters Laboratories Listing and File No. ... Listing No. 87E8; File No. MH14647

2. Dimensions
 - A. Footprint 12' - 6 1/2" x 6' - 8"
 - B. Maximum Length 14' - 6 1/2"
 - C. Maximum Width 6' - 5"
 - D. Maximum Height 8' - 4"
 - E. Chamber Loading Opening 25 3/4" H x 39" W (into chamber)

3. Weight 24,000 lbs.

4. Utility/Air Requirements
 - A. Gross Gas Input, Natural or LP Gas 2,700,000 BTU/hr. max.
 - Running Gas Pressure, Natural Gas 7 inches w.c. or greater
 - Running Gas Pressure, LP Gas 11 inches w.c. or greater
 - B. Electrical Supply 230 volt, 3Ø or 1Ø, 60 hz (other available)
 - C. Air Supply 2,500 cfm

5. Incineration Capacity
 - A. Type 4 Material 200 lbs./hr.

6. Typical Loading Capacity of Material
 - A. Type 4 Material 400 to 750 lbs.

7. Construction and Safety Standards Incineration Institute of America, Underwriters Laboratories

8. Steel Structure Construction
 - A. Frame 2" square tubing
 - B. Front/Rear Plates 3/8" plate
 - C. Floor Plates 3/16" plate
 - D. Outer Side Casing 12 gauge plate
 - E. Inner Side Casing 12 gauge plate

9. Stack Construction
 - A. Inner Wall 4 1/2" insulating firebrick or castable
 - B. Outer Wall 12 gauge plate, type 304 s.s., welded seams

10. Draft Nozzle Construction Schedule 40 type 316 s.s. pipe

11. Main Chamber Door Construction
 - A. Steel Shell 3/16" steel, welded with reinforcement
 - B. Outer Refractory 1" insulating block
 - C. Inner Refractory 4 1/2" insulating firebrick

12. Primary Chamber Wall Construction
 - A. Outer Casing Wall 12 gauge plate

SPECIFICATIONS- Power-Pak II Pet

- B. Inner Frame/Air Compartment 2" air compartment
- C. Inner Casing Wall 12 gauge plate
- D. Outer Refractory Wall 5" insulating block
- E. Inner Refractory Wall 4½" firebrick

- 13. Secondary Chamber Wall Construction
 - A. Outer Casing Wall..... 12 gauge plate
 - B. Inner Frame/Air Compartment 2" air compartment
 - C. Inner Casing Wall 12 gauge plate
 - D. Outer Refractory Wall 6" insulating block
 - E. Inner Refractory Wall 4½" firebrick

- 14. Refractory Temperature Ratings
 - A. Standard Firebrick..... 3,100° F.
 - B. Insulating Firebrick..... 2,600° F.
 - C. Castable Refractory (Hearth) 2,800° F.
 - D. Castable Refractory 2,550° F.
 - E. Insulating Block..... 1,900° F.
 - F. Bonding Mortar 3,200° F.

- 15. Chamber Volumes (not including external flues, stacks or chimneys)
 - A. Primary Chamber..... 64 cubic feet
 - B. Secondary Chamber 74 cubic feet

- 16. Emission Control Features
 - A. Secondary Chamber with Afterburner Included
 - B. Opacity Monitor and Controller with Visual and Audible Alarms..... Included
 - C. Auxiliary Air Control System..... Included
 - D. Microprocessor Temperature Control System..... Included

- 17. Operating Temperatures
 - A. Primary Chamber..... 1,200° F. - 1,800° F.
 - B. Secondary Chamber 1,400° F. - 1,800° F. (as required)

- 18. Secondary Chamber Retention Time
 - A. Type 4 Material > 1 second

- 19. Ash Removal..... Door functions as a heat shield. Sweep out beneath front door into a hopper that fills a collection pan.

- 20. Safety Interlocks
 - A. High Gas Pressure..... Optional
 - B. Low Gas Pressure Optional
 - C. Blower Air Pressure Included
 - D. Door Position Included
 - E. Opacity Included
 - F. Motor Starter Function Included
 - G. Chamber Temperature..... Included
 - H. Motor Overload Included

SPECIFICATIONS- Power-Pak II Pet

- I. Flame Quality..... Included
- J. Burner Safe Start..... Included

- 22. Burner Description..... The nozzle mix burners used on this cremation equipment are industrial quality and designed for incinerator use.

- 23. Ultraviolet Flame Detection..... Ultraviolet flame detection has proven to be the most reliable means of flame safety. The system is completely sealed in a quartz capsule to eliminate problems, caused by moisture and dust created in the cremation process, which effect flame rod detectors.

- 24. Operating Panel Indicating Lights
 - A. Safe Run..... Included
 - B. Door Closed..... Included
 - C. Pollution Alarm..... Included
 - D. Afterburner On (Secondary Burner)..... Included
 - E. Cremation Burners On..... Included
 - F. Low Fire Cremation Burner On..... Included
 - G. Afterburner (Secondary Burner) Reset..... Included
 - H. Cremation Burners Reset..... Included
 - I. Hearth Air..... Included
 - J. Throat Air Off..... Included

- 25. Automatic Timer Functions
 - A. Master Cycle..... Included
 - B. Afterburner (Secondary Burner)..... Included
 - C. Cremation Burners..... Included
 - D. Low Fire Cremation Burner..... Included
 - E. Hearth Air..... Included
 - F. Throat Air..... Included
 - G. Pollution Monitoring..... Included
 - H. Afterburner (Secondary Burner) Prepurge..... Included
 - I. Cremation Burner Prepurge..... Included
 - J. Cool Down..... Included

- 26. Exterior Finish
 - A. Primer..... 2 coats rust inhibiting
 - B. Finish..... 2 coats textured finish

- 27. Start-Up and Training..... Startup of cremation equipment and training of operators to properly operate and maintain the equipment is performed on-site under actual operating conditions. Included is a comprehensive owner's manual, with details on the equipment, its components and proper operation.

- 28. Environmental Submittals..... Complete technical portion of state environmental permits. Engineering calculations,

CREMATOR MASS BALANCE

Matthews International Cremation Division

Industrial Equipment & Engineering Co.

Model IE43-PPII (Power-Pak II) Crematory Incinerator, Fired on Natural Gas
Pet Unit

2-Jan-08

THESE CALCULATIONS HAVE BEEN PREPARED TO EVALUATE THE COMBUSTION
PROCESS IN THE POWER-PAK II CREMATORY INCINERATOR

Firing Rate 200 lb/hr = 100 % of 200 lbs/hr Rated Capacity)

Excess Air 100 %

THE INCINERATOR INSTITUTE OF AMERICA HAS PUBLISHED THE FOLLOWING SPECIFICATIONS
COVERING AVERAGE WASTES.

WASTE TYPE	TYPE 0	TYPE 4
BTU PER POUND	8500	1000
POUND ASH PER POUND WASTE	0.05	0.05
POUND MOISTURE PER POUND WASTE	0.1	0.85
POUND COMBUSTIBLES PER POUND WASTE	0.85	0.1
HOURLY CONSUMPTION OF WASTE (LBS)	1.0	199.0

SPECIFICATIONS		
PRIMARY CREMATION BURNER FUEL CONSUMPTION	0.7	(MMBTU/HR)
SECONDARY CREMATION BURNER FUEL CONSUMPTION	1.0	(MMBTU/HR)
PRIMARY CHAMBER VOLUME (CU.FT)	64	
HEARTH AREA (SQ.FT)	26.4	
SECONDARY BURNER FUEL CONSUMPTION (MMBTU/HR)	1.0	
ADDITIONAL COMBUSTION AIR SUPPLIED		
THROAT AIR (SCFM)	75	
HEARTH AIR (SCFM)	50	
SEC. CHAMBER OPERATING TEMPERATURE (°F)	1800	
SECONDARY CHAMBER VOLUME (CU. FT)	74	
SEC. CHAMB. CROSS-SECTIONAL AREA (SQ. FT)	2.7	
FLAME PORT AREA (SQ. FT)	2.8	
MIXING BAFFLES AREA (SQ. FT)	1.4	

1. TOTAL FLUE PRODUCTS

A. PRIMARY BURNER NATURAL GAS USAGE

$$1700000 \text{ BTU/HR} \times \frac{0.045 \text{ LBS/CF}}{1000 \text{ BTU/CF}} = 77 \text{ LBS/HR}$$

B. COMBUSTION AIR FOR PRIMARY BURNERS

(100 % Excess Air)

$$\frac{1700000 \text{ BTU/HR}}{100 \text{ BTU/SCF AIR}} \times 2 \times 0.075 \text{ LB/CF AIR} = 2550 \text{ LBS/HR}$$

$$= 566.7 \text{ SCFM}$$

C. SECONDARY BURNER NATURAL GAS USAGE

$$1000000 \text{ BTU/HR} \times \frac{0.045 \text{ LBS/CF}}{1000 \text{ BTU/CF}} = 45 \text{ LBS/HOUR}$$

D. COMBUSTION AIR FOR SECONDARY BURNER

(100 % Excess Air)

$$\frac{1000000 \text{ BTU/HR}}{100 \text{ BTU/SCF AIR}} \times 2 \times 0.075 \text{ LB/CF AIR} = 1500 \text{ LBS/HOUR}$$

$$= 333.3 \text{ SCFM}$$

E. PRODUCTS FROM TYPE 0 WASTE (CONTAINER)

$$0.95 \text{ LBS/LB BURNED} \times 1 \text{ LB/HR BURN RATE} = 1 \text{ LBS/HOUR}$$

F. PRODUCTS FROM TYPE 4 WASTE (TISSUE)

$$0.95 \text{ LBS/LB WASTE} \times 199 \text{ LB/HR BURN RATE} = 189 \text{ LBS/HOUR}$$

G. ADDITIONAL COMBUSTION AIR (THROAT & HEARTH AIR)

$$4500 \text{ SCF/HR} \times 0.075 \text{ LB/CF AIR} = 337.5 \text{ LBS/HOUR}$$

$$3000 \text{ SCF/HR} \times 0.075 \text{ LB/CF AIR} = 225 \text{ LBS/HOUR}$$

$$= 281 \text{ LBS/HR/CREMA1}$$

H. TOTAL FLUE PRODUCTS

$$= \underline{\underline{4643 \text{ LBS/HOUR}}}$$

2. VELOCITY AND TIME CALCULATIONS

A. SCFM CALCULATION

(PRODUCTS ASSUMED TO HAVE DENSITY CLOSE TO AIR)

$$4643 \text{ LBS/HR} \times \frac{13.35 \text{ STD. CU. FT/LB}}{60 \text{ MIN/HR}} = 1033 \text{ SCFM}$$

B. TOTAL PRODUCTS ACFM @ 1800 °F

$$\frac{2260 \text{ °RANKINE}}{530 \text{ °RANKINE}} \times 1033 \text{ CFM} = 4405 \text{ ACFM}$$

C. RETENTION TIME

$$\frac{74 \text{ CU. FT}}{4405 \text{ ACFM}} \times \frac{60 \text{ SECONDS}}{1 \text{ MINUTE}} = 1.01 \text{ SECONDS}$$

D. VELOCITY IN FLAME PORT

$$\frac{4405 \text{ ACFM}}{2.8 \text{ SQ. FT}} \times \frac{1 \text{ MINUTE}}{60 \text{ SECONDS}} = 26.2 \text{ FEET/SECOND}$$

E. VELOCITY AT MIXING BAFFLES

$$\frac{4405 \text{ ACFM}}{1.4 \text{ SQ. FT}} \times \frac{1 \text{ MINUTE}}{60 \text{ SECONDS}} = 52.4 \text{ FEET/SECOND}$$

F. VELOCITY IN SECONDARY CHAMBER

$$\frac{4405 \text{ ACFM}}{2.7 \text{ SQ. FT}} \times \frac{1 \text{ MINUTE}}{60 \text{ SECONDS}} = 27.2 \text{ FEET/SECOND}$$

Air Emissions Testing

IE43-PPII, Power-Pak II Cremator

**Reflections Pet Funeral Home
Pinellas Park, Florida**

May 7, 2002

Testing Performed By:

Southern Environmental Sciences, Inc.

1.0 INTRODUCTION

Southern Environmental Sciences, Inc. conducted emissions testing of the Industrial Equipment & Engineering Company Model IE43-PPII, Power-Pak II cremator (serial number 0691201) on May 7, 2002. The unit is located at Reflections Pet Funeral Home in Pinellas Park, Florida (permit number 1030136-004-AC). Testing was conducted for the particulates, carbon monoxide, and visible emissions. Oxygen (O_2) concentrations were measured in order to correct results to 7% O_2 .

2.0 SUMMARY OF RESULTS

The equipment was found to be in compliance with all applicable emission limiting standards. Results of the particulate and carbon monoxide testing for runs 2, 3, and 4 are summarized in Table 1.

The average measured particulate emission concentration was 0.022 grains per dry standard cubic foot (corrected to 7% O_2).

The average measured carbon monoxide emission concentration was 2.5 parts per million by volume (corrected to 7% O_2).

A visible emissions evaluation was conducted over a 60-minute period. The maximum three minute average opacity was 0 percent.

The data for the first run, run 1, were not valid because of a problem with the pitot tube used in the sampling train. The field data sheets for run 1 are included in the appendix. The data were not analyzed.

EMISSIONS TEST SUMMARY

Company: REFLECTION PET FUNERAL HOME
 Source: IEE POWER-PAK II ANIMAL CREMATORY

	Run 2	Run 3	Run 4
Date of Run	5/7/02	5/7/02	5/7/02
Start Time (24-hr. clock)	1456	1628	1916
End Time (24-hr. clock)	1554	1742	2028
Vol. Dry Gas Sampled Meter Cond. (DCF)	31.172	47.554	50.327
Gas Meter Calibration Factor	1.000	1.000	1.000
Barometric Pressure at Barom. (in. Hg.)	30.15	30.09	30.08
Elev. Diff. Manom. to Barom. (ft.)	0	0	0
Vol. Gas Sampled Std. Cond. (DSCF)	30.172	45.527	48.276
Vol. Liquid Collected Std. Cond. (SCF)	2.801	5.587	6.177
Moisture in Stack Gas (% Vol.)	8.5	10.9	11.3
Molecular Weight Dry Stack Gas	29.62	29.36	29.40
Molecular Weight Wet Stack Gas	28.63	28.11	28.11
Stack Gas Static Press. (in. H ₂ O gauge)	-0.02	-0.01	-0.01
Stack Gas Static Press. (in. Hg. abs.)	30.15	30.09	30.08
Average Square Root Velocity Head	0.167	0.196	0.199
Average Orifice Differential (in. H ₂ O)	0.814	1.213	1.290
Average Gas Meter Temperature (Deg. F)	90.8	96.3	95.1
Average Stack Gas Temperature (Deg. F)	1393.5	1291.1	1207.3
Pitot Tube Coefficient	0.84	0.84	0.84
Stack Gas Vel. Stack Cond. (ft./sec.)	17.56	20.27	20.05
Effective Stack Area (sq. ft.)	2.18	2.18	2.18
Stack Gas Flow Rate Std. Cond. (DSCFM)	604	717	741
Stack Gas Flow Rate Stack Cond. (ACFM)	2,298	2,654	2,625
Net Time of Run (min.)	60.0	72.0	72.0
Nozzle Diameter (in.)	0.601	0.601	0.601
Percent Isokinetic	92.3	97.7	100.3
Oxygen (%)	8.4	10.7	10.0
Particulate Collected (mg.)	31.0	56.6	56.5
Particulate Emissions (lb./hr.)	0.082	0.118	0.115
Particulate Emissions (gr./DSCF)	0.016	0.019	0.018
Particulate Emissions (gr./DSCF @ 7% O ₂)	0.018	0.026	0.023
Avg. Particulate Emissions (gr./DSCF @ 7%)		0.022	
Allowable Part. Emissions (gr./DSCF @ 7%)		0.08	
CO Emissions (ppm)	4.1	1.0	1.2
CO Emissions (ppm @ 7% O ₂)	4.6	1.4	1.6
Avg. CO Emissions (ppm @ 7% O ₂)		2.5	
Allowable CO Emissions (ppm @ 7% O ₂)		100	

Note: Standard conditions 68° F, 29.92 in. Hg

**Florida Department of Environmental Protection
Cash Receiving Application (CRA)
Cashlisting by Deposit #: 291132 thru 291132
Printed: 9/9/2008 9:04:55 AM - Page 14**

Cashlisting: 70778 Cashlist Area: 3755 Description: DIV OF AIR RESOURCES MGMT.
Deposit No: 291132 Date Deposited: 09/08/2008 Contact: E. WALKER

Object	Transmittal	Dep DDN	Receipt Number	Pre-Numbered Receipt	Name	Check Number	Payment Amount	Reference Account	Payment Number	Remittance Number	Fund	Grant	
002272	50361	485566	636230		ENVIRONMENTAL CONTROL INC	55787	\$100.00		898754	795184	PFTF		
	50361	485575	636239		STATEMENT POWERBOATS LLC	1300	\$100.00		898772	795193	PFTF		
	50371		636340		LOHMAN PET CEMETERY & CREMATI	1013	\$100.00		898861	795305	PFTF		
Object Code 002272 Subtotal:							\$300.00						
002278	50361	485569	636233		LANG ENVIRONMENTAL INC	33712	\$200.00	50199	898755	795187	APCTF		
	50361	485570	636234		SUNRISE SYSTEMS OF BREVARD INC	037590	\$300.00	50273	898758	795188	APCTF		
	50361	485570	636234		SUNRISE SYSTEMS OF BREVARD INC	037590	\$700.00	50294	898757	795188	APCTF		
	50361	485570	636234		SUNRISE SYSTEMS OF BREVARD INC	037590	\$200.00	50274	898756	795188	APCTF		
	50361	485570	636234		SUNRISE SYSTEMS OF BREVARD INC	037590	\$400.00	50266	898759	795188	APCTF		
	50361	485571	636235		ACT	5483	\$600.00	50108	898761	795189	APCTF		
	50361	485571	636235		ACT	5483	\$300.00	50380	898762	795189	APCTF		
	50361	485571	636235		ACT	5483	\$200.00	50367	898760	795189	APCTF		
	50361	485572	636236		EE&G CONSTRUCTION & ELECTRICAL	1502	\$300.00	50121	898763	795190	APCTF		
	50361	485576	636240		BEST-TEC ABATEMENT	022879	\$200.00	48685	898774	795194	APCTF		
	50361	485576	636240		BEST-TEC ABATEMENT	022879	\$100.00	48932	898773	795194	APCTF		
Object Code 002278 Subtotal:							\$3,500.00						
Cashlisting 70778 Total:							\$3,800.00						

*1370069-005
9/17/2008-AC*

LOHMAN PET CEMETERY & CREMATION, INC.

1013

Florida Department of Environmental

Check Number: 1013

Check Date: Sep 5, 2008

Check Amount: \$100.00

Invoice	Date	Discount Taken	Amount Paid	Quantity	Description
	9/5/08		100.00		Fees, Licenses, Cert

FLORIDA DEPARTMENT OF ENVIRONMENTAL PROTECTION
2008 SEP -3 PM 1:28
TAMPA REVENUE