

**CONCRETE BATCHING PLANT
AIR GENERAL PERMIT REGISTRATION FORM**

RECEIVED
SEP 21 2009
Bureau of Air Quality
& Mobile Sources

Part II. Notification to Permitting Office

(Detach and submit to appropriate permitting office; keep copy onsite)

Instructions: To give notice to the Department of an eligible facility's intent to use this air general permit, the owner or operator of the facility must detach and complete this part of the Air General Permit Registration Form and submit it to the appropriate Department of Environmental Protection or local air pollution control program office which has permitting authority. Please type or print clearly all information, and enclose the appropriate air general permit registration processing fee pursuant to Rule 62-4.050, F.A.C. (\$100 as of the effective date of this form)

0850009-005

Registration Type

Check one:

INITIAL REGISTRATION - Notification of intent to:

- Construct and operate a proposed new facility.
 Operate an existing facility not currently using an air general permit (e.g., a facility proposing to go from an air operation permit to an air general permit).

RE-REGISTRATION (for facilities currently using an air general permit) - Notification of intent to:

- Continue operating the facility after expiration of the current term of air general permit use.
 Continue operating the facility after a change of ownership.
 Make an equipment change requiring re-registration pursuant to Rule 62-210.310(2)(e), F.A.C., or any other change not considered an administrative correction under Rule 62-210.310(2)(d), F.A.C.

Surrender of Existing Air Operation Permit(s) - For Initial Registrations Only

If the facility currently holds one or more air operation permits, such permit(s) must be surrendered by the owner or operator upon the effective date of this air general permit. In such case, check the first box, and indicate the operation permits being surrendered. If no air operation permits are held by the facility, check the second box.

- All existing air operation permits for this facility are hereby surrendered upon the effective date of this air general permit; specifically permit number(s):
0850009-004-AG
 No air operation permits currently exist for this facility.

General Facility Information

Facility Owner/Company Name (Name of corporation, agency, or individual owner who or which owns, leases, operates, controls, or supervises the facility.)

CEMEX Construction Materials Florida, L.L.C.

Site Name (Name, if any, of the facility site; e.g., Plant A, Metropolis Plant, etc. If more than one facility is owned, a registration form must be completed for each.)

CEMEX - Indiantown Ready-Mix

Facility Location (Provide the physical location of the facility, not necessarily the mailing address.)

Street Address: 17200 Railroad Avenue

City: Indiantown

County: Martin

Zip Code: 34956

Facility Start-Up Date (Estimated start-up date of proposed new facility.)(N/A for existing facility)

N/A

Owner/Authorized Representative

Name and Position Title (Person who, by signing this form below, certifies that the facility is eligible to use this air general permit.)

Print Name and Title: Jeffrey R. Porter - Environmental Manager, Southeast Florida Materials Division

Owner/Authorized Representative Mailing Address

Organization/Firm: CEMEX Construction Materials Florida, L.L.C.

Street Address: 1501 Belvedere Road

City: West Palm Beach

County: Palm Beach

Zip Code: 33406

Owner/Authorized Representative Telephone Numbers

Telephone: (561) 820-8415

Fax: (561) 820-8643

Cell phone (optional): (561) 718-7564

Facility Contact (If different from Owner/Authorized Representative)

Name and Position Title (Plant manager or person to be contacted regarding day-to-day operations at the facility.)

Print Name and Title: Scott Morgan - Stuart Operations Foreman

Facility Contact Mailing Address

Organization/Firm: CEMEX Construction Materials Florida, L.L.C.

Street Address: 17200 Railroad Avenue

City: Indiantown

County: Martin

Zip Code: 34956

Facility Contact Telephone Numbers

Telephone: (772) 287-0502

Fax: (772) 221-3656

Cell phone (optional): (561) 262-2324

Owner/Authorized Representative Statement

This statement must be signed and dated by the person named above as owner or authorized representative

I, the undersigned, am the owner or authorized representative of the owner or operator of the facility addressed in this Air General Permit Registration Form. I hereby certify, based on information and belief formed after reasonable inquiry, that the facility addressed in this registration form is eligible for use of this air general permit and that the statements made in this registration form are true, accurate and complete. Further, I agree to operate and maintain the facility described in this registration form so as to comply with all applicable standards for control of air pollutant emissions found in the statutes of the State of Florida and rules of the Department of Environmental Protection and revisions thereof.

I will promptly notify the Department of any changes to the information contained in this registration form.

Signature

9/10/09
Date

Type of Facility

Check one:

Stationary Facility

Relocatable Facility

Type(s) of Reasonable Precautions Used to Prevent Unconfined Emissions

Check all precautions to be used for the management of roads, parking areas, stock piles and yards:

Pave Roads

Pave Parking Areas

Pave Yards

Maintain Roads/Parking/Yards

Use Water Application

Use Dust Suppressant

Remove Particulate Matter

Reduce Stock Pile Height

Install Wind Breaks

Check all precautions to be used for the management of drop points to trucks:

Spray Bar

Chute

Enclosure

Partial enclosure

Description of Reasonable Precautions

Below, or as an attachment to this form, provide details of all types of reasonable precautions to be used to prevent unconfined emissions at the facility.

This facility is provided with an extensive stormwater/wastewater drainage system, which is designed to flush particulate matter from the paved yard and entrance drive. This keeps the paving cleaner, substantially reducing fugitive emissions. Aggregate stockpiles in the yard are stored on paved surfaces and kept watered, partly for quality control and partly to reduce potential emissions from these materials. Unused concrete which is brought back to the site is stored in a concrete-walled washout structure, which reduces the area needed to dry the material, while keeping it out of the main traffic pattern, where it would generate additional fugitive emissions.

Description of Facility

Below, or as an attachment to this form, provide a description of the concrete batching plant operations at the facility in sufficient detail to demonstrate the facility's eligibility for use of this air general permit and to provide a basis for tracking any future equipment or process changes at the facility. Describe all air pollutant-emitting processes and equipment at the facility, and identify any air pollution control measures or equipment used.

Ready-Mix Concrete Batching Facility, which utilizes cement, flyash, slag and aggregate materials to produce ready-mix concrete. Dust emissions generated during the filling of the plant's silos or loading of concrete mixer trucks are controlled by cartridge dust collectors. Details of these emissions units (EU's) are as follows:

EU-01 - Cement silo compartment no. 1 (with a C. & W. Dust Systems Model CP-305-839 cartridge dust collector / Proposed).

EU-02 - Cement silo compartment no. 2 (with a C. & W. Dust Systems Model CP-305-839 cartridge dust collector / Proposed).

EU-03 - Cement weigh hopper (with a C. & W. Dust Systems Model CP-100-127 cartridge batcher vent).

NOTE: THIS PRINT NOT FOR
CONSTRUCTION. FOR
GENERAL REF. ONLY

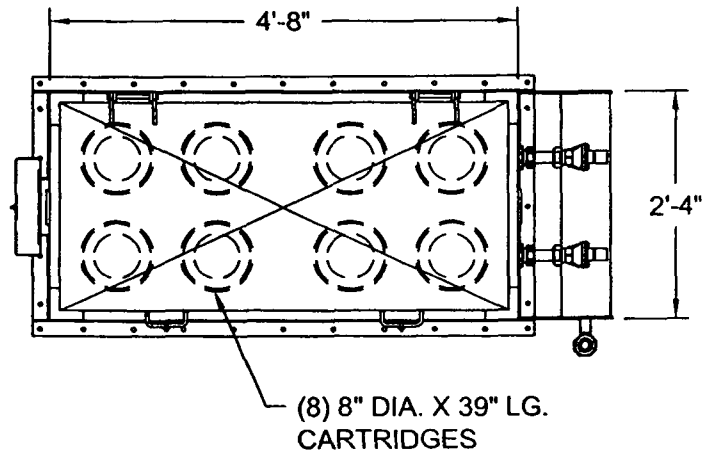

TOP VIEW

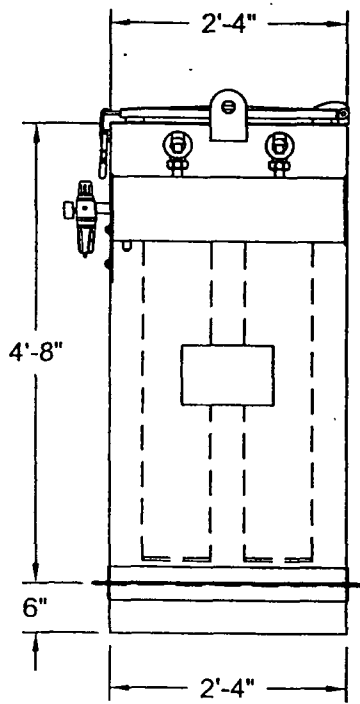

FRONT VIEW

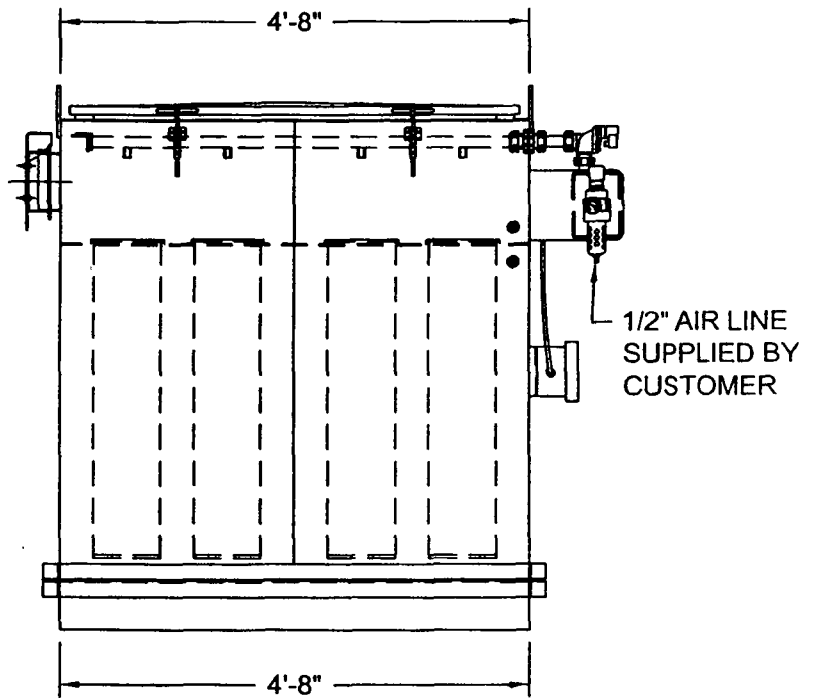

SIDE VIEW

CP-305-839 PULSE JET COLLECTOR



C & W MFG. & SALES CO.
6933 SHELMOR RD.
ALVARADO, TX. 76009 (817) 790-5000

**Specifications for CP Silo Collectors
at 6" Static Pressure**

Model Number	CP-230-639	CP-300-839	CP-310-478	CP-380-1039	CP-450-678	CP-610-878
Number of Cartridges	6	8	4	10	6	8
Cartridge Diameter & Length	8"x39"	8"x39"	8"x78"	8"x39"	8"x78"	8"x78"
Number of Solenoids	2	2	2	2	2	2
Total Filtration Area	228	304	304	380	456	608
Min. Design Efficiency	99.99%	99.99%	99.99%	99.99%	99.99%	99.99%
Air to Cloth Ratio (ACFM/Ft.2)	3.5	5.3	5.3	5.3	5.5	4.9
Filtration Velocity (Ft./Min.)	3.5	5.3	2.6	5.3	5.5	4.9
Blower Horsepower (optional)	2	3	3	3	5	5
Static Pressure Drop (WC)	6"	6"	6"	6"	6"	6"
Normal Air Capacity	850	1600	1600	2000	2500	3000
Outlet Area (Ft.2)	0.196	0.64	0.64	0.81	0.79	1.00
Outlet Velocity (Ft./Sec.)	68.03	41.67	41.67	41.15	52.74	50.00
Outlet Moisture Content (Ideally)	0	0	0	0	0	0
Cleaning Mechanism	Pulse Jet w/ Timer	Pulse Jet w/ Timer	Pulse Jet w/ Timer	Pulse Jet w/ Timer	Pulse Jet w/ Timer	Pulse Jet w/ Timer
*Inlet Dust Concentration	12,000	24,000	24,000	30,000	37,500	45,000
*Outlet Emissions (Gr/Min)	1.20	2.40	2.40	3.00	3.75	4.50
*Outlet Dust Loading (Gr/Cf)	0.0015	0.0015	0.0015	0.0015	0.0015	0.0015
*These Calculations Based on Inlet Loading of 15 Gr. / Ft. 3 Your State Environmental Dept. may request additional information. If so, contact C & W Engineering The Fabric Material is 100% Spun Bound Polyester The Approximate Weight of the Filter Media is 8.1Oz.						

**Specifications for CP Silo Collectors
at 6" Static Pressure**

Model Number	CP-760-1078	CP-900-1278	CP-1220-1678	CP-1520-2078	CP-2250-3078
Number of Cartridges	10	12	16	20	30
Cartridge Diameter & Length	8"X 78"	8"X 78"	8"X 78"	8"X 78"	8"X 78"
Number of Solenoids	2	3	4	5	6
Total Filtration Area	760	912	1216	1520	2280
Min. Design Efficiency	99.99%	99.99%	99.99%	99.99%	99.99%
Air to Cloth Ratio (ACFM/Ft.2)	5.3	5.5	5.5	5.5	5.5
Filtration Velocity (Ft./Min.)	5.3	5.5	5.5	5.5	5.5
Blower Horsepower (optional)	7.5	10	15	20	25
Static Pressure Drop (WC)	6"	6"	6"	6"	6"
Normal Air Capacity	4,000	5,000	6,700	8,400	12,400
Outlet Area (Ft.2)	1.09	1.31	2.29	2.85	4.19
Outlet Velocity (Ft./Sec.)	61.16	63.61	48.76	49.12	49.32
Outlet Moisture Content (Ideally)	0	0	0	0	0
Cleaning Mechanism	Pulse Jet Nozzle W/Preset timer	Pulse Jet Nozzle W/Preset timer	Pulse Jet Nozzle W/Preset timer	Pulse Jet Nozzle W/Preset timer	Pulse Jet Nozzle W/Preset timer
*Inlet Dust Concentration	60,000	75,000	100,500	126,000	186,000
*Outlet Emissions (Gr/Min)	6.00	7.50	10.05	12.60	18.60
*Outlet Dust Loading (Gr/Cf)	0.0015	0.0015	0.0015	0.0015	0.0015
*These Calculations Based on Inlet Loading of 15 Gr. / Ft. 3 Your State Environmental Dept. may request additional information. If so, contact C & W Engineering					

SPECIFICATIONS

Questions? Call 1-800-880-3878 for C & W Customer Support



RECEIVED
SEP 21 2009
Bur...
& Mobile Sources

CERTIFIED - RETURN RECEIPT REQ.
7009 0960 0000 2312 7619

September 11, 2009

Florida Dept. of Environmental Protection
Receipts
P. O. Box 3070
Tallahassee, FL 32315-3070

RE: General air permit modification for the CEMEX / Indiantown ready-mix concrete facility (permit no. 0850009-004-AG).

Dear Sirs:

This letter is intended to serve as notification that our company plans to modify the dust collection systems at our Indiantown concrete facility, which is located at 17200 Railroad Avenue, northwest of Indiantown, Florida.

Specifically, two Besser-APPCO Model DCS-260 baghouses, which currently serve the site's twin-compartment cement silo, will be replaced with two new C. & W. Dust Systems Model CP-305-839 cartridge dust collectors.

In order to update the general air permit for this location, we have attached an FDEP Air General Permit Registration Form, a set of dust collector specifications and check no. 21889319 in the amount of \$100.00. Visible emissions tests will be performed on the new dust collectors within thirty days of their installation.

If you have any questions concerning the application or need additional data to complete your review, please contact us at (561) 820-8415.

Sincerely,

Jeffrey R. Porter
Environmental Manager

Page 2
FDEP / Receipts
Indiantown - AG Mod.

Attachments

cc: M. Manolas
S. Morgan
T. Mazzola
D. Corrales
K. Arlington (Arlington Env.)
File (Indiantown)

EMEX

1501 Belvedere Road
West Palm Beach, FL 33406

REGISTERED MAIL™

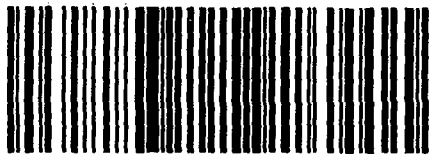

7009 0960 0000 2312 7619



Florida Dept. of Environmental Protection
Receipts
P. O. Box 3070
Tallahassee, FL 32315-3070