



Florida Department of Environmental Protection

Bob Martinez Center
2600 Blair Stone Road
Tallahassee, Florida 32399-2400

Charlie Crist
Governor

Jeff Kottkamp
Lt. Governor

Michael W. Sole
Secretary

January 21, 2009

Mr. Ricardo Russian
Operations US Manager
Inno Vida Southeast LLC
Inno Vida Holdings, Incorporated
470 Northeast 185th Street
North Miami Beach, Florida 33179

Dear Mr. Russian:

This is to acknowledge that your notification of intent to use the authority of Rule 62-210.310 to operate your facility was received on December 17, 2008. We have assigned ARMS No. 0251299-001 to this facility.

As you know, pursuant to Florida Statutes section 403.814, authority to operate under general permits commences thirty (30) days after receipt of the registration form unless you have been notified by this office that your facility has not shown entitlement to operate pursuant to the rule provisions.

For your information, authority to operate pursuant to Rule 62-210.310 expires after five (5) years. Therefore, a new registration form must be received no later than five (5) years after the date your notice was received as indicated above. If your general permit rule conditions require testing, such testing must be completed within the time frame specified in the rule.

If you have any additional questions, please contact Dickson Dibble at 850/921-9586.

Sincerely,

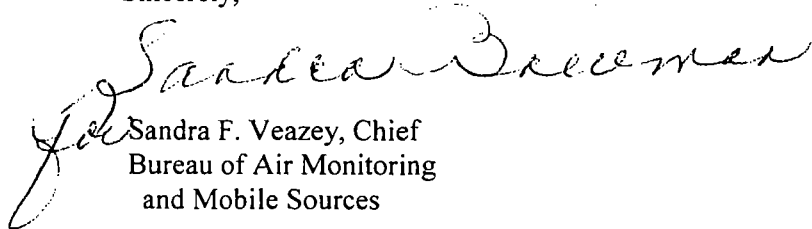

Sandra F. Veazey, Chief
Bureau of Air Monitoring
and Mobile Sources

SFV/pg

F&A RECEIPT 2008 DEC 17

Bureau of Air Monitoring
by Multiple Sources

DEC 23 2008

RECEIVED

**REINFORCED POLYESTER RESIN OPERATIONS
AIR GENERAL PERMIT REGISTRATION FORM**

Part II. Notification to Permitting Office

(Detach and submit to appropriate permitting office; keep copy onsite)

Instructions: To give notice to the Department of an eligible facility's intent to use this air general permit, the owner or operator of the facility must detach and complete this part of the Air General Permit Registration Form and submit it to the appropriate Department of Environmental Protection or local air pollution control program office which has permitting authority. Please type or print clearly all information, and enclose the appropriate air general permit registration processing fee pursuant to Rule 62-4.050, F.A.C. (\$100 as of the effective date of this form)

0251299-001

Registration Type

Check one:

INITIAL REGISTRATION - Notification of intent to:

- Construct and operate a proposed new facility.
- Operate an existing facility not currently using an air general permit (e.g., a facility proposing to go from an air operation permit to an air general permit).

RE-REGISTRATION (for facilities currently using an air general permit) - Notification of intent to:

- Continue operating the facility after expiration of the current term of air general permit use.
- Continue operating the facility after a change of ownership.
- Make an equipment change requiring re-registration pursuant to Rule 62-210.310(2)(e), F.A.C., or any other change not considered an administrative correction under Rule 62-210.310(2)(d), F.A.C.

Surrender of Existing Air Operation Permit(s) - For Initial Registrations Only

If the facility currently holds one or more air operation permits, such permit(s) must be surrendered by the owner or operator upon the effective date of this air general permit. In such case, check the first box, and indicate the operation permits being surrendered. If no air operation permits are held by the facility, check the second box.

- All existing air operation permits for this facility are hereby surrendered upon the effective date of this air general permit; specifically permit number(s):
- No air operation permits currently exist for this facility.

General Facility Information

Facility Owner/Company Name (Name of corporation, agency, or individual owner who or which owns, leases, operates, controls, or supervises the facility.)

InnoVida Southeast LLC

Site Name (Name, if any, of the facility site; e.g., Plant A, Metropolis Plant, etc. If more than one facility is owned, a registration form must be completed for each.)

Facility Location (Provide the physical location of the facility, not necessarily the mailing address.)

Street Address: 470 NE 185th st

City: North Miami Beach

County: Miami-Dade

Zip Code: 33179

PAGE 6 - ADDENDUM TO
12/17/08 APPLICATION

Dibble, Dickson

From: Rafael Abreu [Rafael.Abreu@InnoVida.com]
Sent: Wednesday, December 31, 2008 11:37 AM
To: Dibble, Dickson
Cc: Ricardo Russian; Mario Sanchez; Walter Rest
Subject: Facility Start-Up Date for March 31, 2009

Mr. Dibble, thank you so much for calling me this morning regarding my call from last week.

Per your request, please allow this email to formally document on DEP form No. 62-210.920(1)(d) with effective date January 10th 2009

the Facility Start-Up Date for March 31, 2009

RE: InnoVida Southeast LLC

470 NE 185th Street

North Miami Beach, Miami-Dade 33179

Mr. Dibble, per our conversation, you indicated that the Air General Permit Registration Form - DEP form No. 62-210.920(1)(d) was received at your office on December 17th 2008 and that after 30 days, providing very thing is in order, InnoVida should receive a letter from your office acknowledging approval for the Air General Permit and Facility I.D. number. In addition, a new application and fee shall be submitted if there is a change in ownership or if there are major changes in equipment.

On behalf of InnoVida, we hope you have a very happy and prosperous New Year 2009.

If you need additional information or if you have any questions, please do not hesitate to contact me at your convenience.

Thank you,

Rafael Abreu, CSHM
Safety Risk Director
InnoVida Group of Companies
Office: +1 786-837-7200 Ext. 40321
Fax: +1 305-249-8325
Cell: 305-898-8277
Rafael.Abreu@InnoVida.com



CONFIDENTIALITY NOTE: The information contained in this transmission is privileged and confidential information intended only for the use of the individual or entity named above. If the reader of this message is not the intended recipient, you are hereby notified that any dissemination, distribution or copying of this communication is strictly prohibited. If you have received this transmission in error, do not read it. Please immediately reply to the sender that you have received this communication in error and then delete it. Thank you.

 Save trees... please consider the importance before printing this email...

PAGE 6 - ADDENDUM

12/31/2008

Owner/Authorized Representative

Name and Position Title (Person who, by signing this form below, certifies that the facility is eligible to use this air general permit.)

Print Name and Title: Mario Sanchez

Owner/Authorized Representative Mailing Address

Organization/Firm: InnoVida Holdings, Inc

Street Address: 560 Lincoln Rd. Ste. 303

City: Miami Beach

County: Miami-Dade

Zip Code: 33184

Owner/Authorized Representative Telephone Numbers

Telephone: 786-837 7200

Fax: 305-674 8369

Cell phone (optional): x 40316

Facility Contact (If different from Owner/Authorized Representative)

Name and Position Title (Plant manager or person to be contacted regarding day-to-day operations at the facility.)

Print Name and Title: Ricardo Russian / Operations US Manager

Facility Contact Mailing Address

Organization/Firm: InnoVida Southeast LLC

Street Address: 470 NE 185th st

City: North Miami Beach

County: Miami-Dade

Zip Code: 33179

Facility Contact Telephone Numbers

Telephone: 786-837 7200

Fax: 305-674 8369

Cell phone (optional):

Owner/Authorized Representative Statement

This statement must be signed and dated by the person named above as owner or authorized representative

I, the undersigned, am the owner or authorized representative of the owner or operator of the facility addressed in this Air General Permit Registration Form. I hereby certify, based on information and belief formed after reasonable inquiry, that the facility addressed in this registration form is eligible for use of this air general permit and that the statements made in this registration form are true, accurate and complete. Further, I agree to operate and maintain the facility described in this registration form so as to comply with all applicable standards for control of air pollutant emissions found in the statutes of the State of Florida and rules of the Department of Environmental Protection and revisions thereof.

I will promptly notify the Department of any changes to the information contained in this registration form.

Signature

Date

12/01/2008

Material Usage Rates

If this is an **initial registration** for a reinforced polyester resin operation, provide an estimate of the total quantity, in pounds, of styrene-containing materials (resin and gelcoat) expected to be used over a 12-month period. Note: the general permit limits the usage of such material to 76,000 pounds (38 tons) in any consecutive 12 months.

76000

If this is a **re-registration** for a reinforced polyester resin operation, provide the highest 12-month total quantity, in pounds, of styrene-containing materials (resin and gelcoat) used in the last five years. Indicate the 12-month period over which this usage occurred.

Description of Facility

Below, or as an attachment to this form, provide a description of the reinforced polyester resin operations at the facility in sufficient detail to demonstrate the facility's eligibility for use of this air general permit and to provide a basis for tracking any future equipment or process changes at the facility. Describe all air pollutant-emitting processes and equipment at the facility, and identify any air pollution control measures or equipment used.

Our CSIPs (Composite Structural Insulated Panels) come in 3 standard thicknesses - 104mm, 64mm, and 44mm, depending on whether they will be used for internal or external walls and/or roofs. Our panels can be made out of polyurethane (PU) for building construction, or can be made with honeycomb for floating platform applications.

Our panels can also be made to spec in virtually any dimension, shape, and/or level of thickness that is required. For example - in the case of hurricane shutters, our panels will be shaped in the dimension, shape, and thickness of a plywood board, or a metal sheet shutter. In this particular example our panels will be stronger than the current materials used in the industry, but in addition they can be custom made to have the exact specs of an arch window or an oddly shaped door. It can be made with matching colors of existing walls.

InnoVidaPanels™, InnoVidaResin™ and InnoVidaBond™ are produced using proprietary synthetic composite materials and industrial processes similar to those now generally accepted by the marine and aircraft construction industries. InnoVidaPanels™, made from InnoVidaResin™, provide a stronger, lighter, and more flexible alternative to traditional construction materials of cement, steel or bricks. For example, panels can take a vertical load of 50 tons/m² and horizontal load of 2 tons/m². Because of their unique properties, InnoVidaPanels™ are nonflammable, waterproof, and hurricane resistant up to 186mph (300km/h), and their polyurethane insulation allows for significant noise reduction and better preservation of room temperature. Additionally, the use of InnoVidaBond™ materials to join the panels together results in a chemical fusion rendering the structure virtually waterproof. Construction of structures made from InnoVida materials can be completed in a few days without requiring heavy equipment.

The facility uses proprietary tables, equipment and resins to manufacture the composite panels. They are currently purchasing polyisocyanurate panels for use in the process.

My Home
Miami-Dade County, Florida

MIAMI-DADE

miamidade.gov

Property Information Map

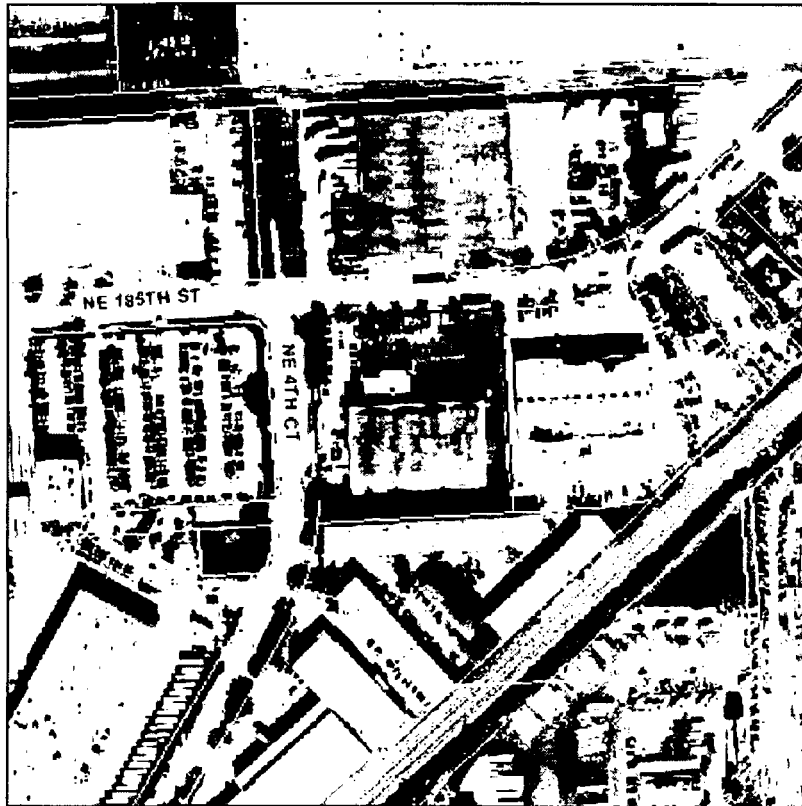

Digital Orthophotography - 2007

0 — 134 ft

This map was created on 12/1/2008 12:39:13 PM for reference purposes only.

Web Site © 2002 Miami-Dade County. All rights reserved.

Summary Details:

Folio No.:	30-2206-017-0061
Property:	470 NE 185 ST
Mailing Address:	MARTIN & MARGARET B WEISS % GEORGE MCELROY & ASSOCIATES INC PO BOX 565048 DALLAS TX 75356-

Property Information:

Primary Zone:	7300 INDUSTRIAL-HEAVY
CLUC:	0032 LIGHT MANUFACTURING
Beds/Baths:	0/0
Floors:	1
Living Units:	0
Adj Sq Footage:	35,016
Lot Size:	99,369 SQ FT
Year Built:	1971
Legal Description:	6 52 42 2.27 AC M/L PB 81-80 MIAMI INDUSTRIAL DISTRICT SEC 5 PORT TR 5-K - BEG AT SW COR N275.03FT NELY FOR AD 39.27FT E305FT S300FT W331.23FT TO POB LOT SIZE 99369 SQ FT

Sale Information:



Sale O/R:	000000000
Sale Date:	2/1971
Sale Amount:	\$59,400

Assessment Information:

Year:	2008	2007
Land Value:	\$1,291,797	\$1,291,797
Building Value:	\$608,203	\$434,965
Market Value:	\$1,900,000	\$1,726,762
Assessed Value:	\$1,900,000	\$1,726,762

Taxable Value Information:

Year:	2008	2007
Taxing Authority:	Applied Exemption/ Taxable Value:	Applied Exemption/ Taxable Value:
Regional:	\$0/ \$1,900,000	\$0/ \$1,726,762
County:	\$0/ \$1,900,000	\$0/ \$1,726,762
School Board:	\$0/ \$1,900,000	\$0/ \$1,726,762

	EXP+	Pieces: 1/1
FM: InnoVida Southeast LLC Nanette Riemer 470 NE 185 Street North Miami Beach, FL 33179 UNITED STATES Phone: 786-837-7200		ORIGIN: MMR Sender's ref. air general permit
To: FDEP 3800 COMMONWEALTH BLVD MS-77 TALLAHASSEE, FL 32399 UNITED STATES		POSTCODE: 32399 TEL:
Description:		Time 10:30
Weight: Letter Date: 2008-12-16 DHL standard terms and conditions apply.		
 (2.)US32399		TLHI 6Z FSC
 WAYBILL: 29848859655		(Non-Negotiable)

Florida Department of Environmental Protection
Cash Receiving Application (CRA)
Cashlisting by Deposit #: 291316 thru 291316
Printed: 12/17/2008 4:03:07 PM - Page 11

Cashlisting: **72764** Cashlist Area: **3755** Description: **DIV OF AIR RESOURCES MGMT.**
 Deposit No: **291316** Date Deposited: **12/17/2008** Contact: **E. WALKER**

Object	Transmittal	Dep.DDN	Receipt Number	Pre- Numbered Receipt	Name	Check Number	Payment Amount	Reference Account	Payment Number	Remittance Number	Fund	Grant
002272	52012	489864	647677		BERKSHIRE DRY CLEANERS	1242	\$100.00	12/18/2008-PR	915314	807684	PFTF	
	52031		647714		INNOVIDA SERVICES	1759	\$100.00	0251299-001	915340	807748	PFTF	
Object Code 002272 Subtotal:							\$200.00					
002309	52012	489867	647680		ORANGE COUNTY BOCC	0000729818	\$150.00		915318	807687	PFTF	
Object Code 002309 Subtotal:							\$150.00					
Cashlisting 72764 Total:							\$350.00					

Innovida Services Inc

1759

Miami Dade Environmental Resource December 12, 2008

Document No.	Document Date	Description	Amount	Net Amount
AUSFL1-08-PV100261	12/12/08	Invoice AUSFL1-08-PI100272	100.00	100.00

FLORIDA DEPARTMENT OF
2008 DEC 17 AM 11:38
RECEIVED

Total

100.00