

F&A RECEIPT # 519952

DATE: MAR 25 2011 RECEIVED

HUMAN CREMATORY
AIR GENERAL PERMIT REGISTRATION FORM

MAR 29 2011

Bureau of Air Monitoring
& Mobile Sources

Part II. Notification to Permitting Office

(Detach and submit to appropriate permitting office; keep copy onsite)

Instructions: To give notice to the Department of an eligible facility's intent to use this air general permit, the owner or operator of the facility must detach and complete this part of the Air General Permit Registration Form and submit it to the appropriate Department of Environmental Protection or local air pollution control program office which has permitting authority. Please type or print clearly all information, and enclose the appropriate air general permit registration processing fee pursuant to Rule 62-4.050, F.A.C. (\$100 as of the effective date of this form)

0090054-006

Registration Type

Check one:

INITIAL REGISTRATION - Notification of intent to:

- Construct and operate a proposed new facility.
- Operate an existing facility not currently using an air general permit (e.g., a facility proposing to go from an air operation permit to an air general permit).

RE-REGISTRATION (for facilities currently using an air general permit) - Notification of intent to:

- Continue operating the facility after expiration of the current term of air general permit use.
- Continue operating the facility after a change of ownership.
- Make an equipment change requiring re-registration pursuant to Rule 62-210.310(2)(e), F.A.C., or any other change not considered an administrative correction under Rule 62-210.310(2)(d), F.A.C.

Surrender of Existing Air Operation Permit(s) - For Initial Registrations Only

If the facility currently holds one or more air operation permits, such permit(s) must be surrendered by the owner or operator upon the effective date of this air general permit. In such case, check the first box, and indicate the operation permits being surrendered. If no air operation permits are held by the facility, check the second box.

- All existing air operation permits for this facility are hereby surrendered upon the effective date of this air general permit; specifically permit number(s): _____
- No air operation permits currently exist for this facility.

General Facility Information

Facility Owner/Company Name (Name of corporation, agency, or individual owner who or which owns, leases, operates, controls, or supervises the facility.)

Beckman-Williamson Funeral Home, LLC

Site Name (Name, if any, of the facility site; e.g., Plant A, Metropolis Plant, etc. If more than one facility is owned, a registration form must be completed for each.)

Atlas Crematory

Facility Location (Provide the physical location of the facility, not necessarily the mailing address.)

Street Address: 2111 South U.S. Highway 1

City: Rockledge

County: Brevard

Zip Code: 32955 - 3726

Facility Start-Up Date (Estimated start-up date of proposed new facility.) (N/A for existing facility)

N/A existing facility.

Owner/Authorized Representative

Name and Position Title (Person who, by signing this form below, certifies that the facility is eligible to use this air general permit.)

Print Name and Title: Charles Sikes, President

Owner/Authorized Representative Mailing Address

Organization/Firm: Beckman-Williamson, LLC
Street Address: 101 North Brevard Avenue
City: Cocoa Beach County: Brevard Zip Code: 32931

Owner/Authorized Representative Telephone Numbers

Telephone: 321-784-0116 Fax: 321-781-8304
Cell phone (optional):

Facility Contact (If different from Owner/Authorized Representative)

Name and Position Title (Plant manager or person to be contacted regarding day-to-day operations at the facility.)

Print Name and Title:

Facility Contact Mailing Address

Organization/Firm:
Street Address:
City: County: Zip Code:

Facility Contact Telephone Numbers

Telephone: Fax:
Cell phone (optional):

Owner/Authorized Representative Statement

This statement must be signed and dated by the person named above as owner or authorized representative

I, the undersigned, am the owner or authorized representative of the owner or operator of the facility addressed in this Air General Permit Registration Form. I hereby certify, based on information and belief formed after reasonable inquiry, that the facility addressed in this registration form is eligible for use of this air general permit and that the statements made in this registration form are true, accurate and complete. Further, I agree to operate and maintain the facility described in this registration form so as to comply with all applicable standards for control of air pollutant emissions found in the statutes of the State of Florida and rules of the Department of Environmental Protection and revisions thereof.

I will promptly notify the Department of any changes to the information contained in this registration form.

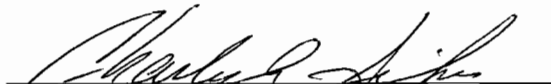
Signature

3/23/11
Date

Design Calculations

If this is an initial registration for a proposed new human crematory unit, provide design calculations to confirm a sufficient volume in the secondary chamber combustion zone to provide for at least a 1.0 second gas residence time at 1800 degrees F.

- Manufacturer's design calculations attached. - See Attachment 1 for compliance test report
 Registration is not for proposed new human crematory unit(s).

Description of Facility

(NEED INFORMATION FOR ALL UNITS)

Below, or as an attachment to this form, provide a description of all crematory operations at the facility in sufficient detail to demonstrate the facility's eligibility for use of this air general permit and to provide a basis for tracking any future equipment or process changes at the facility. Describe all air pollutant-emitting processes and equipment at the facility, and identify any air pollution control measures or equipment used.

Equipment Description

Atlas Crematory is replacing a Power Pak II crematory with a U.S. Cremation Equipment Model "Classic" manufactured by U.S. Cremation Equipment.

The "Classic" is a multi-chamber unit having an average 150 - 200 lbs/hr fired with natural gas. The primary chamber burner is rated at 500,000 Btu/hr, and the secondary chamber burner is rated at 1,500,000 Btu/hr, for a total of 2,000,000 Btu/hr. Control of air pollution is achieved through the design of the "Classic" crematory, including its ability to operate the secondary chamber between 1600 - 1850 degrees Fahrenheit at a residence time in excess of 1.0 second. The design also includes fully automatic PLC based controls, independent fuel/air systems, preheated combustion air, secondary chamber temperature monitor and recorder, primary burner temperature interlock (prevents primary burner from firing prior to the secondary chamber reaching its set point temperature), UV continuous scanning flame detectors on burners, and an opacity sensor which can temporarily suspend operation of the primary chamber burner. In attachment 2 we have include a copy of the crematory spec.

Emissions Summary

Emission Summary and Calculations - Air pollution control is demonstrated through identical source stack testing. (see Attachment 1). See Attachment 3 for tabular summary of emissions. Criteria pollutant emissions values, except CO and PM are based on emission factors from AP-42, Table 2.1-12. The emission for CO and PM are derived from results of the identical source stack test.

Retention Time

The retention time was measured on an identical unit at 1.95 seconds at 1800°F.

** SEE ATTACHED E-MAIL DATED 04/07/11
AS AN ADDENDUM TO THIS FORM.*

PROVIDES A LIST OF EXISTING EQUIPMENT.

R

From: Luis Llorens [ai@cfl.rr.com]
Sent: Thursday, April 07, 2011 8:48 AM
To: Dibble, Dickson
Cc: cwilkerson@uscremationequipment.com
Subject: Atlas Crematory AIRS ID# 0090054-005-AG
Attachments: 2011-04-05 Guiding Light 0112701.pdf

Dear Dick:

The model and serial number of the cremators currently installed at Atlas Crematory are:

B & L
Model N20AA
Serial # 636-419-02

Mathews
Model PP II
Serial # 374329

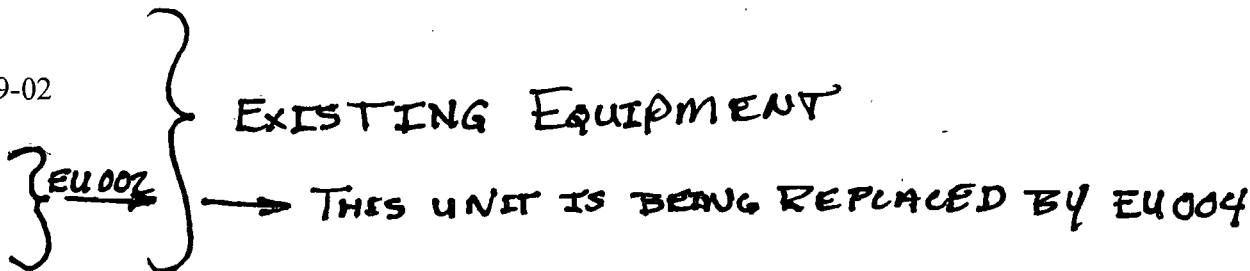

Regarding the stack test submitted, the unit was a "Classic Cremator" I asked the test firm to clear that up. See Attached letter.

If you have any more questions, please call me at 407-574-2021 or reply to this email.

Respectfully,
AI ENVIRONMENTAL CONSULTING SERVICES, INC.

Luis Llorens

Dibble, Dickson

From: Dibble, Dickson
Sent: Wednesday, March 30, 2011 9:23 AM
To: 'llorens@americanincinerators.com'
Cc: Ajhar, Rebecca
Subject: Airs ID# 0090054-005-AG; Beckman-Williamson Funeral Home LLC dba Atlas Crematory, 2111 US Hwy 1, Rockledge, FL 32955-3726
Attachments: ID#0090054;Beckman_WilliamsonFuneralHomeLLCdbaAtlasCrematory.pdf

Tracking:	Recipient	Delivery	Read
	'llorens@americanincinerators.com'		
	Ajhar, Rebecca	Delivered: 3/30/2011 9:23 AM	Read: 3/30/2011 9:25 AM

Good morning Luis!

I hope this e-mail finds you well.

I am in receipt of a Human Crematory Air General Permit Registration Form for the subject item facility which was prepared by AI Environmental Consulting Services for the purpose of replacing an IE&E, Power Pak II human cremator with a US Cremation Equipment "Classic" Model US 100, cremation unit.

I have performed a cursory review of the form (see pdf file attached) and made an equipment comparison between the Registration form and our database records. Our database records indicate that there is a second cremation unit on site, but the form makes no reference to it. In order for me to perform a thorough review of the facility and complete the registration and entitlement process, the form (Description of Facility-Page 9) should include the identifying details (**Make, Model, & S/N**) of all existing tort units, not just the unit being replaced or installed.

The form reads:

Description of Facility

Below, or as an attachment to this form, provide a description of **all** crematory operations at the facility in sufficient detail to demonstrate the facility's eligibility for use of this air general permit and to provide a basis for tracking any future equipment or process changes at the facility. Describe **all** air pollutant-emitting processes and equipment at the facility, and identify any air pollution control measures or equipment used.

If you, or the preparer of this form can provide me with the identification information for the second unit, I would greatly appreciate it. You may provide the information via e-mail and I will simply attach the e-mail as an addendum to the Registration form

Secondly, the Registration form indicates that Compliance Test Results are from a identical unit, but nowhere in the Compliance Test Report, Attachments #1, and 1A through 1F is there any reference to a specific Make and Model of the unit being tested. The only cross reference made in the report is that the tests were performed at "...Unit #2 at Guiding Light Cremations, LLC, ID 0112701 located at 2431 SW 56th Terrace in West Park, Florida.". If you would be so kind, in the future please make sure there is a reference to the Make and Model of the identical tested equipment on the Compliance Test Report which is being submitted.

Thank you for your assistance in these matters and if you have any questions, comments or concerns please e-mail or call.

Have a great day!

Sincerely yours,

Dickson E. Dibble

Dickson E. Dibble, ES III

Air General Permit Program
FL Dept of Environmental Protection
Div. of Air Resource Management
Bureau of Air Monitoring & Mobile Sources
Tel. (850) 717-9071
FAX (850) 717-9001
GIC - #59571
Dickson.Dibble@dep.state.fl.us



Please note: Florida has a very broad public records law. Most written communications to or from state officials regarding state business are public records available to the public and media upon request. Your e-mail communications may therefore be subject to public disclosure

Dibble, Dickson

From: Luis Llorens [llorens@americanincinerators.com]
Sent: Wednesday, March 30, 2011 12:27 PM
To: Dibble, Dickson
Cc: cwilkerson@uscremationequipment.com
Subject: RE: Airs ID# 0090054-005-AG; Beckman-Williamson Funeral Home LLC dba Atlas Crematory, 2111 US Hwy 1, Rockledge, FL 32955-3726

Dear Dick:

I certified that the units are the same and are identical. The cremators at Guiding Light cremations are U.S. Cremation Equipment model "Classic".

I took a look at the report and Arlington Environmental did not write it in the report. They are providing me with a letter stating this fact.

I will contact Atlas and get the serial numbers and models for you.

Luis

From: Dibble, Dickson [<mailto:Dickson.Dibble@dep.state.fl.us>]
Sent: Wednesday, March 30, 2011 9:23 AM
To: llorens@americanincinerators.com
Cc: Ajhar, Rebecca
Subject: Airs ID# 0090054-005-AG; Beckman-Williamson Funeral Home LLC dba Atlas Crematory, 2111 US Hwy 1, Rockledge, FL 32955-3726

Good morning Luis!

I hope this e-mail finds you well.

I am in receipt of a Human Crematory Air General Permit Registration Form for the subject item facility which was prepared by AI Environmental Consulting Services for the purpose of replacing an IE&E, Power Pak II human cremator with a US Cremation Equipment "Classic" Model US 100, cremation unit.

I have performed a cursory review of the form (see pdf file attached) and made an equipment comparison between the Registration form and our database records. Our database records indicate that there is a second cremation unit on site, but the form makes no reference to it. In order for me to perform a thorough review of the facility and complete the registration and entitlement process, the form (Description of Facility-Page 9) should include the identifying details (**Make, Model, & S/N**) of all existing tort units, not just the unit being replaced or installed.

The form reads:

Description of Facility

Below, or as an attachment to this form, provide a description of all crematory operations at the facility in sufficient detail to demonstrate the facility's eligibility for use of this air general permit and to provide a basis for tracking any future equipment or process changes at the facility. Describe all air pollutant-emitting processes and equipment at the facility, and identify any air pollution control measures or equipment used.

If you, or the preparer of this form can provide me with the identification information for the second unit, I would greatly appreciate it. You may provide the information via e-mail and I will simply attach the e-mail as an addendum to the Registration form

Secondly, the Registration form indicates that Compliance Test Results are from a identical unit, but nowhere in the Compliance Test Report, Attachments #1, and 1A through 1F is there any reference to a specific Make and Model of the unit being tested. The only cross reference made in the report is that the tests were performed at "...Unit #2 at Guiding

Light Cremations, LLC, ID 0112701 located at 2431 SW 56th Terrace in West Park, Florida.". If you would be so kind, in the future please make sure there is a reference to the Make and Model of the identical tested equipment on the Compliance Test Report which is being submitted.

Thank you for your assistance in these matters and if you have any questions, comments or concerns please e-mail or call.

Have a great day!

Sincerely yours,

Dickson E. Dibble

Dickson E. Dibble, ES III

Air General Permit Program
FL Dept of Environmental Protection
Div. of Air Resource Management
Bureau of Air Monitoring & Mobile Sources
Tel. (850) 717-9071
FAX (850) 717-9001
GIC - #59571

Dickson.Dibble@dep.state.fl.us



Please note: Florida has a very broad public records law. Most written communications to or from state officials regarding state business are public records available to the public and media upon request. Your e-mail communications may therefore be subject to public disclosure

The Department of Environmental Protection values your feedback as a customer. DEP Secretary Herschel T. Vinyard Jr. is committed to continuously assessing and improving the level and quality of services provided to you. Please take a few minutes to comment on the quality of service you received. Simply click on [this link to the DEP Customer Survey](#). Thank you in advance for completing the survey.



Arlington Environmental Services, Inc.

Post Office Box 657 ~ Okeechobee, Florida 34973
605 SW Park Street, Suite 209 ~ Okeechobee, Florida 34974
Telephone (863) 467-0555 ~ Facsimile (863) 357-0810
www.arlingtonenvironmental.com

U.S. Cremation Equipment
598 South Northlake Boulevard, Suite 1016
Altamonte Springs, FL 32701

RE: FID 0112701 – Guiding Light Cremations, LLC
Emission Testing Conducted March 3 & 4, 2010
Make: US Cremation Equipment
Model: Classic Human Crematory

To Whom It May Concern:

Emission testing for Particulate, Visible, Carbon Monoxide, and Hydrogen Chloride, EPA Methods 1-5, 9, 10, and 26A, was conducted on March 3 & 4, 2010 at the above referenced facility. The units tested were manufactured by US Cremation Equipment and both units were model Classic Human Crematory. In the event you have any questions please do not hesitate to contact me at (863) 467-0555.

Sincerely,

Noah A. Handley, P.E.
Vice President, Principal Engineer,
Arlington Environmental Services, Inc.

***Attachment 1
Compliance Test Report***

1. The purpose of this report is to provide a detailed account of the compliance testing conducted on the [Product Name] system. The testing was performed to ensure that the system meets the requirements specified in the [Standard Name] and to identify any areas of non-compliance.

2. The testing was conducted over a period of [Duration] and involved the following activities:

- Review of the system architecture and design documents.
- Execution of test cases designed to verify compliance with the [Standard Name].
- Analysis of the test results and identification of any non-compliance issues.
- Implementation of corrective actions to address the identified issues.

3. The results of the testing indicate that the system is in compliance with the [Standard Name] in all areas tested, except for the following:

- [Issue 1]
- [Issue 2]

4. The corrective actions taken to address the identified issues are as follows:

- [Action 1]
- [Action 2]

5. The system is now in compliance with the [Standard Name] and is ready for deployment.



Arlington Environmental Services, Inc.

"Specializing in Visible Emission and Stack Testing"

April 7, 2010

ELECTRONIC CORRESPONDENCE

Broward County
Air Quality Division
1 North University Drive, Suite 203
Plantation, Florida 33324

Re: Guiding Light Cremations LLC, Unit 2
AIRS ID: 0112701

To Whom It May Concern:

On March 03 and 04, 2010, source tests for particulate, visible and carbon monoxide (EPA Methods 1-5, 9 and 10) were conducted on the exhaust stack servicing the crematory incinerator, Unit #2 at Guiding Light Cremations, LLC, ID 0112701 located at 2431 SW 56th Terrace in West Park, Florida.

The tests were performed in order to comply with the Broward County Department of Planning and Environmental Protection, Air Quality Division, Chapter 27 Article IV, Air Quality, Section 27-179(c)(2). The results comply with Florida's Human Crematory Rule 62-296.401(5), FAC.

The following emission point was tested:

- o EU002 Exhaust stack servicing the afterburner

To the best of my knowledge, this completes all of the required initial tests. If, for any reason, this is incorrect, please contact me as soon as possible.

Sincerely,

Debra Carter

/dc

Electronic Copy to: Geronimo Mena, Jr., Guiding Light Cremations LLC
David Krohn, Guiding Light Cremations, LLC

Post Office Box 657 ~ Okeechobee, Florida 34973
Telephone (863) 467-0555 ~ Facsimile (863) 357-0810
Email info@arlingtonenvironmental.com ~ Website www.arlingtonenvironmental.com

**Source Test Report
for
Particulate, Visible and CO Emissions**

EPA Methods 1-5, 9 and 10

Report 2985-S

March 03 and 04, 2010

prepared for

**Guiding Light Cremations, LLC
Unit #2
Facility ID 0112701**



Arlington Environmental Services, Inc.

Post Office Box 657 ~ Okeechobee, Florida 34973 ~ Telephone 863.467.0555

Table of Contents

	<u>Page</u>
1.0 Introduction	1
2.0 Certification of Test Results.....	2
3.0 Allowable Emission Determination	3
4.0 Cyclonic Flow Determination.....	3
5.0 Summary of Results.....	4
6.0 Particulate Emission Results.....	5
7.0 Visible Emission Results	6
8.0 Carbon Monoxide Emission Results.....	7
9.0 Overview of Field and Analytical Procedures.....	8
9.1 EPA Method 1	8
9.2 EPA Method 2	8
9.3 EPA Method 3	8
9.4 EPA Method 4	9
9.5 EPA Method 5	9
9.6 EPA Method 9	10
9.7 EPA Method 10	10
10.0 Sampling Point Determination.....	11
10.1 Number of Sampling Points per Traverse	12
11.0 Summary of Field and Laboratory Data.....	13
Attachment A - Field Data	
Attachment B - Laboratory Data	
Attachment C - Process Data	
Attachment D - Calculations for Run 1	
Attachment E - Calibration Data	
Attachment F - Project Participants	

1.0 Introduction

Guiding Light Cremations LLC operates a human crematory located at 2431 SW 56th Terrace in West Park, FL. On March 03 and 04, 2010, source tests for particulate, visible and carbon monoxide emissions (EPA Methods 1-5, 9 and 10) were conducted on Unit #2 exhaust stack servicing the crematory incinerator.

The tests were performed in order to comply with the Broward County Department of Planning and Environmental Protection, Air Quality Division, Chapter 27 Article IV, Air Quality, Section 27-179(c)(2). The results comply with Florida's Human Crematory Rule 62-296.401(5), FAC.

Courtney Pitters of the Broward County Division of Environmental Protection, Air Quality Division was present for a portion of the tests.

The retention time for this unit during the test was 1.75 seconds. The substantiating calculations are presented in Appendix D.

The average particulate emission rate, as determined by EPA Method 5, was 0.0159 gr/dscf . (corrected to 7% O₂). The allowable particulate emission rate is 0.080 gr./dscf . (corrected to 7% O₂).

The average carbon monoxide emission rate as determined by EPA Method 10, was 0.86 ppm . (corrected to 7% O₂). The allowable carbon monoxide emission rate is 100 ppm (corrected to 7% O₂).

The average visible emission rate as determined by EPA Method 9, was 0.0%. The allowable visible emission rate (highest six minute average) is 5% with up to 15% allowed in a one hour period.

The results of this test verify compliance with the Florida Department of Environmental Protection Human Crematory Rule 62-296.401(5), Florida Administrative Code.

2.0 Certification of Test Results

Facility Tested: Guiding Light Cremations LLC
2431 SW 56th Terrace
West Park, FL 33325

Type Process - Human Crematory

Abatement Device - Afterburner

Report 2985-S

March 03 and 04, 2010

Run Numbers 1, 2 and 3

Actual Particulate Emissions - 0.0159gr/dscf (corrected to 7% O₂)

Allowable Particulate Emissions - 0.0800 gr./dscf (corrected to 7% O₂)

Actual Carbon Monoxide Emissions - 0.86 ppm (corrected to 7% O₂)

Allowable Carbon Monoxide Emissions - 100 ppm (corrected to 7% O₂)

Actual Visible Emissions - 0.0%

Allowable Visible Emissions - 5% with up to 15% allowed in a one hour period

All testing and analysis were performed in accordance with the Florida Department of Environmental Protection Human Crematory Rule 62-296.401(5), Florida Administrative Code.

I hereby certify that to my knowledge, all information and data submitted in this report is true and correct.



William D. Arlington
Project Director

3.0 Allowable Emission Determination

The allowable emissions were determined in accordance with 62.296.401(5) F.A.C. Substantiating data and calculations are presented in the Appendix D.

4.0 Cyclonic Flow Determination

Due to the configuration of the system, cyclonic flow was considered to be non-existent at the sampling site.

5.0 Summary of Results
 Guiding Light Cremations, LLC
 Unit #2
 Report 2985-S

	Run 1	Run 2	Run 3	Average
Date	3/3/2010	3/4/2010	3/4/2010	
Start Time	16:20	9:30	11:00	
Stop Time	17:23	10:33	12:05	
Process Rate (lbs.)	175	180	—	178
Particulate Emission Rate (gr./dscf @ 7% O ₂)	0.0188	0.0099	0.0189	0.0159
Allowable Particulate Emission Rate (gr./dscf @7% O ₂)	0.080	0.080	0.080	0.080
Visible Emission Rate (%) (highest six minute average)				0.00
Allowable Visible Emission Rate (%) (with up to 15% for 6 min. per hour)				5
Carbon Monoxide Emission Rate (ppm @7% O ₂)	0.79	1.04	0.74	0.86
Allowable Carbon Monoxide Emission Rate (ppm @7% O ₂)	100	100	100	100

6.0 Particulate Emission Results
 Guiding Light Cremations, LLC
 Unit #2
 Report 2985-S

	Run 1	Run 2	Run 3
Area (square feet)	3.08	3.08	3.08
Stack Pressure (inches Hg)	29.88	30.07	30.07
Meter Pressure (inches Hg)	30.06	30.26	30.29
Sample Volume (Std. Cu. Ft.)	52.965	54.952	57.861
Water Vapor (Cubic Feet)	5.52	5.85	6.03
Sample Moisture (percent)	9.44	9.62	9.43
Saturation Moisture (percent)	100.00	100.00	100.00
Molecular Weight (lbs/lb Mole wet)	28.29	28.18	28.27
Velocity (fpm)	887	879	985
Volumetric Flow Rate (acfm)	2734	2710	3036
Volumetric Flow Rate (scfm)	891	933	963
Concentration (gr/dscf)	0.0101	0.0051	0.0104
Concentration@7% O2 (gr/dscf)	0.0188	0.0099	0.0189
Mass Emission Rate (lbs./hr.)	0.08	0.04	0.09
Percent Isokinetic	99.51	98.54	100.56

7.0 Visible Emission Results
Guiding Light Cremations, LLC
Unit #2
Report 2985-S

Emission Point	Allowable Emission Rate (highest six minute average)	Emission Rate (highest six minute average)	Average Opacity
Exhaust Stack	0	0.00	0.00

8.0 Carbon Monoxide Emission Results
Guiding Light Cremations, LLC
Unit #2
Report 2985-S

	Run1	Run 2	Run 3	Average
Date	3/3/2010	3/4/2010	3/4/2010	
Start Time	16:20	9:30	11:00	
Stop Time	17:23	10:33	12:05	
Percent Oxygen	13.43	13.79	13.23	
Carbon Monoxide (PPM)	0.42	0.53	0.41	
Carbon Monoxide Emissions (PPM @ 7% O ₂)	0.79	1.04	0.74	0.86
Carbon Monoxide Allowable (PPM@ 7% O ₂)	100	100	100	100

9.0 Overview of Field and Analytical Procedures

9.1 EPA Method 1 - Sample and Velocity Traverses for Stationary Sources

Principle - To aid in the representative measurement of pollutant emissions and/or total volumetric flow rate from a stationary source, a measurement site where the effluent stream is flowing in a known direction is selected and the cross-section of the stack is divided into a number of equal areas. A traverse point is then located within each of these equal areas. See Sampling Point Determination.

Applicability - This method is applicable to flowing gas streams in ducts, stacks and flues. This method cannot be used when: 1) flow is cyclonic or swirling 2) a stack is smaller than about 12 inches in diameter, or 0.071 cross-sectional area or 3) the measurement site is less than two stack or duct diameters downstream or less than a half diameters upstream from a flow disturbance. The procedures in this method were utilized in its entirety according to the procedures outlined in 40 CFR Part 60, Appendix A.

9.2 EPA Method 2 - Determination of Stack Gas Velocity and Volumetric Flow Rate

Principle - Type S Pitot Tube - The average gas velocity in a stack is determined from the gas density and from measurement of the average velocity head with a Type S pitot tube.

Applicability - This method is applicable for measurement of the average velocity of a gas stream and for quantifying gas flow.

This procedure is not applicable at measurement sites which fail to meet the criteria of Method 1. This method cannot be used for direct measurement in cyclonic or swirling gas streams. The procedures in this method were utilized in its entirety according to the procedures outlined in 40 CFR Part 60, Appendix A.

9.3 Method 3 - Gas Analysis for the EPA Determination of Dry Molecular Weight

Principle - A gas sample is extracted from a stack by one of the following methods 1) Single-point grab sampling 2) single-point, integrated sampling or 3) multi-point, integrated sampling, the gas sample is analyzed for percent CO₂, percent O₂, and if necessary for CO. For dry molecular weight determination, either an Orsat or a Fyrite analyzer may be used for the analysis.

Applicability - This method is applicable for determining carbon dioxide and oxygen concentrations and dry molecular weight of a sample from a gas stream of a fossil fuel combustion process. The method may also be applicable to other processes where it has been determined that compounds other than CO₂, O₂, CO, and nitrogen are not present in concentrations sufficient to affect the results. The procedures in this method were utilized in its entirety according to the procedures outlined in 40 CFR Part 60, Appendix A.

9.4 EPA Method 4 - Determination of Moisture Content in Stack Gases

Principle - A gas sample is extracted at a constant rate from the source; moisture is removed from the sample stream and determined either volumetrically or gravimetrically.

Applicability - This method is applicable for determining the moisture content of stack gas. There are two procedures given to determine the moisture. The procedure for the reference method to determine the moisture content was used to calculate the emission data. The reference method was conducted simultaneously with the pollutant emission measurement run, calculation of percent isokinetic, pollutant emission rate, etc. for the run is based upon the results of the reference method or its equivalent. The procedures in this method were utilized in its entirety according to the procedures outlined in 40 CFR Part 60, Appendix A.

9.5 EPA Method 5 - Determination of Particulate Emissions from Stationary Sources

Principle - Particulate matter is withdrawn isokinetically from the source and collected on a glass fiber filter maintained at a temperature in the range of 120 - 248° For such other temperature as specified by an applicable subpart of the standards or approved by the Administrator, U.S. Environmental Protection Agency, for a particular application.

The particulate mass which includes any material that condenses at or above the filtration temperature, is determined gravimetrically after removal of uncombined water.

Applicability - This method is applicable for the determination of particulate emissions from stationary sources. The procedures in this method were utilized in its entirety according to the procedures outlined in 40 CFR Part 60, Appendix A.

Diagram of EPA Method 5 Sampling Train

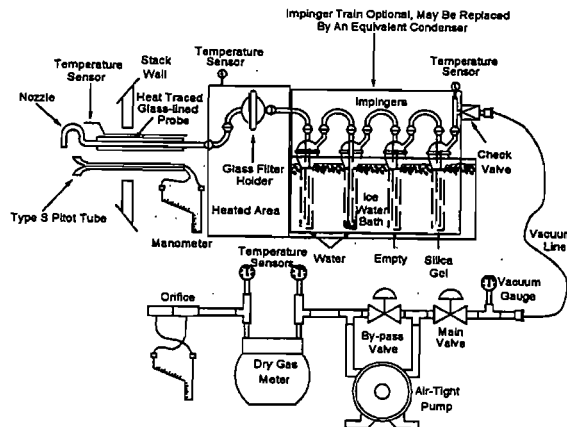

Figure F5-1. Particulate Sampling Train.

9.6 EPA Method 9 - Visual Determination of the Opacity of Emissions from Stationary Sources

Principle - The opacity of emissions from stationary sources is determined visually by a qualified observer.

Applicability - This method is applicable for the determination of the opacity of emissions from stationary sources pursuant to 60.11(b) and for qualifying observers for visually determining the opacity of emissions.

9.7 EPA Method 10 - Determination of Carbon Monoxide Emissions from Stationary Sources

Principle - An integrated or continuous gas sample is extracted from a sampling point and analyzed for carbon monoxide (CO) content using a Luft-type nondispersive infrared analyzer or equivalent.

Applicability - This method is applicable for the determination of carbon monoxide emissions from stationary sources only when specified by the test procedures for determining compliance with new source performance standards. The procedures in this method were utilized in its entirety according to the procedures outlined in 40 CFR Part 60, Appendix A.

10.0 Sampling Point Determination Minimum Number of Sampling Points

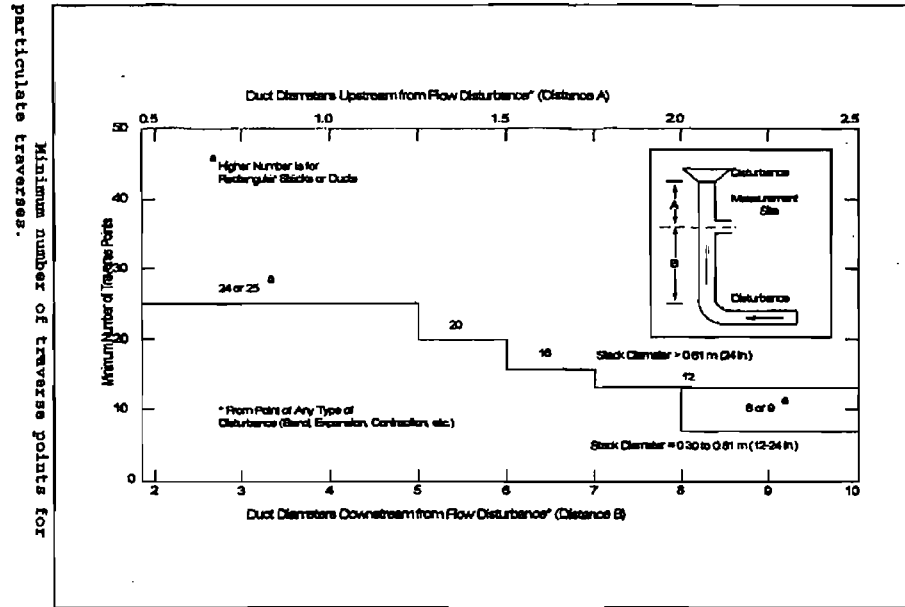

Per Particulate Traverse

Circular Stacks

The number of sampling points is selected according to the above diagram, with the number of points equaling the next higher multiple of four.

Rectangular Stacks

The number of sampling points is determined using the matrix below.

Number of Traverse Points	Subarea Layout Matrix
9	3 x 3
12	4 x 3
16	4 x 4
20	5 x 4
25	5 x 5
30	6 x 5
36	6 x 6
42	7 x 6
49	7 x 7

10.1 Sampling Point Determination
 Guiding Light Cremations, LLC
 Unit #2
 Report 2985-S

Stack Configuration	Rectangular
Side 1 - with ports (inches)	24
Side 2 - (inches)	18.5
Equivalent Diameter	20.89
Distance A - Ports to Downstream Disturbance (inches)	24
Distance A - Ports to Downstream Disturbance (diameters)	1.15
Distance B - Ports to Upstream Disturbance (inches)	48
Distance B - Ports to Upstream Disturbance (diameters)	2.30
Number of Test Ports	6
Number of Sampling points per Traverse	5
Number of Points Sampled	25

Photograph of Stack

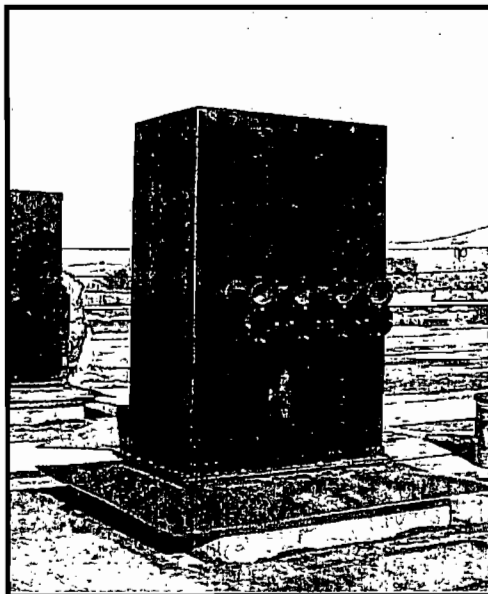

Traverse Point Location	
Traverse Point No.	Inches to Stack Wall
1	1.9
2	5.6
3	9.3
4	13.0
5	16.7

11.0 Summary of Field and Laboratory Data
 Guiding Light Cremations, LLC
 Unit #2
 Report 2985-S

	Run 1	Run 2	Run 3
Date	3/3/2010	3/4/2010	3/4/2010
Start Time	16:20	9:30	11:00
Stop Time	17:23	10:33	12:05
CP	0.84	0.84	0.84
Y	0.9947	0.9947	0.9947
ΔH_a (inches H ₂ O)	1.7304	1.7304	1.7304
Diameter of Nozzle (inches)	0.7503	0.7503	0.7503
Stack Diameter or Equivalent (inches)	20.89	20.89	20.89
Static Pressure (inches H ₂ O)	-0.02	-0.02	-0.02
Barometric Pressure (inches Hg)	29.88	30.07	30.07
Test Time (minutes)	60	60	60
Meter Volume (cubic feet)	53.623	54.165	57.845
Square Root ΔP (inches H ₂ O)	0.156	0.159	0.171
Orifice Pressure ΔH (inches H ₂ O)	2.458	2.583	3.000
Average Meter Temperature (Deg. F)	74.0	63.4	71.4
Average Stack Temperature (Deg. F)	1004.4	931.5	1054.1
Particulate Sample Weight (grms)	0.0347	0.0181	0.0391
Water Collected (grms)	117.1	124.1	127.8
Percent CO ₂	5.1	4.5	5.0
Percent O ₂	13.4	13.8	13.2
Molecular Weight (lbs/lb Mole)	29.36	29.27	29.33
Nozzle Area (square feet)	0.00307	0.00307	0.00307

Attachment A - Field Data



Arlington Environmental Services, Inc.
(863) 467-0555

VISIBLE EMISSION TEST

Method Used (Circle One) Method 9 203A 203B Report # 2985-S

Company Name Everglades Crematorium
 Facility Name AIRS 0112701
 Street Address 2431 SW 56 Terrace
 City West Park FL Zip 33023
 Phone No. (954) 381-8888

Process Human Crematory Unit # 2 Operating Mode N18016S
 Control Equipment After burner Operating Mode N1625°F

Describe Emission Point Rectangular Stack
 Ht of Emis. Point ~20' Ht Rel to Observer ~15'
 Distance to Emis. Pt. ~800' Direction to Emis. Pt (Degrees) ~338°

Vertical Angle to Obs. <18° Direction to Obs. Pt. (Degrees) ~338°
 Distance and Direction to Obs. Pt from Emission Pt ~11' above

Describe Emissions None
 Emission Color Clear Water Droplet Plume None X
 Attached Detached

Describe Plume Background SKY
 Background Color Blue & White Sky Conditions Scattered
 Wind Speed ~12-15 MPH Wind Direction NW
 Ambient Temp. ~58°F Wet Bulb Temp. % RH

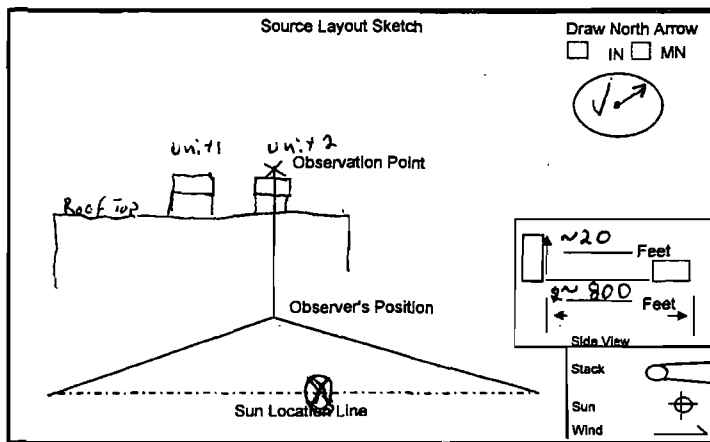

Latitude Longitude Declination

Comments

Min Sec	Observation Date				Start Time				Stop Time			
	0	15	30	45	0	15	30	45	0	15	30	45
1	0	0	0	0	31	0	0	0	0	0	0	0
2	0	0	0	0	32	0	0	0	0	0	0	0
3	0	0	0	0	33	0	0	0	0	0	0	0
4	0	0	0	0	34	0	0	0	0	0	0	0
5	0	0	0	0	35	0	0	0	0	0	0	0
6	0	0	0	0	36	0	0	0	0	0	0	0
7	0	0	0	0	37	0	0	0	0	0	0	0
8	0	0	0	0	38	0	0	0	0	0	0	0
9	0	0	0	0	39	0	0	0	0	0	0	0
10	0	0	0	0	40	0	0	0	0	0	0	0
11	0	0	0	0	41	0	0	0	0	0	0	0
12	0	0	0	0	42	0	0	0	0	0	0	0
13	0	0	0	0	43	0	0	0	0	0	0	0
14	0	0	0	0	44	0	0	0	0	0	0	0
15	0	0	0	0	45	0	0	0	0	0	0	0
16	0	0	0	0	46	0	0	0	0	0	0	0
17	0	0	0	0	47	0	0	0	0	0	0	0
18	0	0	0	0	48	0	0	0	0	0	0	0
19	0	0	0	0	49	0	0	0	0	0	0	0
20	0	0	0	0	50	0	0	0	0	0	0	0
21	0	0	0	0	51	0	0	0	0	0	0	0
22	0	0	0	0	52	0	0	0	0	0	0	0
23	0	0	0	0	53	0	0	0	0	0	0	0
24	0	0	0	0	54	0	0	0	0	0	0	0
25	0	0	0	0	55	0	0	0	0	0	0	0
26	0	0	0	0	56	0	0	0	0	0	0	0
27	0	0	0	0	57	0	0	0	0	0	0	0
28	0	0	0	0	58	0	0	0	0	0	0	0
29	0	0	0	0	59	0	0	0	0	0	0	0
30	0	0	0	0	60	0	0	0	0	0	0	0

Number of Readings Above % were Average Opacity for Highest 6 Min Period 0

Range of opacity Readings Average Opacity for 2nd Highest 6 Min Period 0
 Min 0 Max 0

Observers Name (Print) Steve Webb

Observers Signature Stephen L. Webb Date 3-4-10

Organization Arlington Environmental Services, Inc.

Certified By Whitlow Enterprises Date 1/15/10



Whitlow Enterprises, LLC

www.smokeschool.net

Certifies that

Stephen Webb of Coastal Air Consulting

**Has passed the certification test required by EPA Method 9
40 CFR 60 Appendix A and is qualified as a visible emissions evaluator.**

Certification Date: 1/15/2010 Location: Tampa/Mulberry, FL

George Whitlow

President

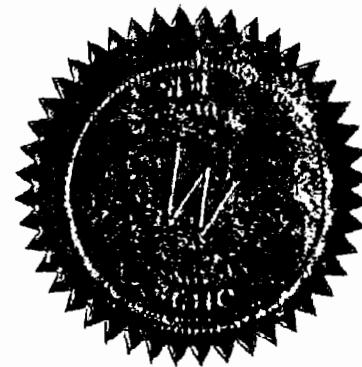

TMFL011510-32

Attachment B - Laboratory Data

Particulate Laboratory Data
Guiding Light Cremations, LLC
Unit #2
Report 2985-S

Run 2

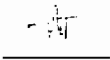
Filter Number	1485	
	Final Weight	0.3827 grams
	Tare Weight	0.3704 grams
	Difference	0.0123 grams
Beaker Number	2C	
	Final Weight	117.5130 grams
	Tare Weight	117.5064 grams
	Difference	0.0066 grams
Filter Blank Number	1483	
	Final Weight	0.3700 grams
	Tare Weight	0.3699 grams
	Difference	0.0001 grams
Wash Down Blank		
	Volume of Rinse	95 mls
	Solution Residue	0.00000784 grams/ml
	Total Residue	0.0007448 grams/ml
Total Particulate Weight		0.0181 grams
Water Collected		
	Final Impinger Water	315 MLS
	Initial Impinger Water	200 MLS
	Final Silica Weight	209.3 GRAMS
	Silica Tare Weight	200.0 GRAMS
Total Water Collected		124.1 grams
Analyst		

Attachment C - Process Data

Emission Control Device and Process Data

Company Guiding Light Cremations

Installation Unit #2

Date 3-4-10 Report No. 2985-S

Type of Installation Crematory

Type of Material Processed Human Remains

Type(s) of Fuel Used Natural Gas

Type of Pollution Control System Afterburner

General Condition of Control Equipment Normal

Run No.	1	2	3
Run No.	3-3-10	3-4-10	3-4-10
Start Time	16:20	9:30	11:00
Stop Time	17:23	10:33	12:05
Fuel Used	NG	NG	NG
Scrubber Water Flow Rate (GPM)	NA	NA	NA
Pressure Drop (in. H ₂ O)	NA	NA	NA
Total Operating Temp °F	1680	1630	1720
Process Rate (lbs/Hr.)	175	- 180 -	
Percent Recycle	NA	NA	NA

Signature  Title _____

Name _____
(Please Print)

Attachment D - Calculations for Run 1

STACK AREA
 (SIDE 1) X (SIDE 2) / 144
 24.00 X 18.50 / 144
 3.08 SQ.FT.

STACK PRESSURE
 BAROMETRIC PRESSURE + (STATIC PRESSURE/ 13.6)
 29.88 + (-0.02 /13.6)
 29.88 IN.HG

METER PRESSURE
 BAROMETRIC PRESSURE + (ORIFICE PRESURE/13.6)
 29.88 + (2.46 / 13.6)
 30.06 IN.Hg

SAMPLE VOLUME
 17.64 X (Y) X METER VOLUME X METER PRESSURE / (METER TEMP. + 460)
 17.64 X 0.9947 X 53.623 X 30.06 / (74.0 + 460)
 52.965 STD.CU.FT.

WATER VAPOR VOLUME
 .04715 X WATER COLLECTED
 0.04715 X 117.1
 5.52 STD.CU.FT.

SAMPLE MOISTURE
 100 X WATER VAPOR VOLUME / (WATER VAPOR VOLUME + SAMPLE VOLUME)
 100 X 5.52 / (5.52 + 52.965)
 9.44 %

SATURATION MOISTURE
 100 X (VAPOR PRESSURE @ STACK TEMP. / STACK PRESSURE)
 100 X (##### / 29.88)
 100.00 %

STACK MOISTURE FRACTION
 (THE LESSER OF SAMPLE MOISTURE OR SATURATION MOISTURE) / 100
 0.094

DRY MOLECULAR WEIGHT OF STACK GAS
 (.28 X (100-%N2)) + (.44 X %CO2) + (.32 X %O2)
 (.28 X (100 - (5.14 + 13.43) + (.44) 5.1 + (.32) 13.43)
 29.36

MOLECULAR WEIGHT OF STACK GAS

$$\frac{29.36 \times (1 - 0.094) + (18 \times 0.094)}{28.29}$$

STACK VELOCITY

$$\frac{85.49 \times 0.840 \times 60 \times 0.156 \times \text{SQ.}(1004.4 + 460)}{29.88 \times 28.29 \times \text{SQ.}(887 \text{ FPM})}$$

VOLUMETRIC FLOW RATE (ACFM)

$$3.08 \times 887 = 2734 \text{ ACFM}$$

VOLUMETRIC FLOW RATE (SCFM) DRY

$$\frac{17.64 \times 2734 \times 29.88 \times (1 - 0.094)}{1004.4 + 460} = 891 \text{ SCFM (DRY)}$$

CONCENTRATION (gr/dscf)

$$\frac{0.0347 \times 15.43}{52.96} = 0.0101$$

CONCENTRATION@7% O2 (gr/dscf)

$$\frac{0.0101 \times 13.9}{20.9 - 13.43} = 0.0188$$

MASS EMISSION RATE (LBS./HR.)

$$0.0101 \times 891 \times \frac{60}{7000} = 0.08 \text{ LBS/HR}$$

PERCENT ISOKINETIC

$$\frac{0.0945 \times (29.88 \times 887 \times 60)}{(1004.38 + 460) \times 52.96 \times 60 \times (1 - 0.094)} = 99.51 \%$$

RESIDENCE TIME CALCULATION			
CORRECTION FOR QUENCHED AIR AT OUTLET			
PLANT:	Guiding Light		
SOURCE:	Unit #2		
LOCATION:			
DATE:			
STACK PRESSURE:	30.07		
CHARGE RATE:			
SOURCE PARAMETERS			
	<u>OUTLET STACK</u>	<u>AMBIENT AIR</u>	<u>SECONDARY CHAMBER</u>
TEMPERATURE,F	1064	65	1624
AIR FLOW,ACFMD	2662		
AIR FLOW,ACFM	2826		
H2O FLOW,ACFM	164		
PRESSURE,PSI	14.77	14.77	14.77
AIR ENTHALPY,BTU/LB	375.5	125.4	528.0
H2O ENTHALPY,BTU/LB	709.8	231.2	1012.2
SCC VOLUME,CFT			71
HUMIDITY RATIO		0.02	
<u>EQUATIONS</u>			
1. MASS = PVM/RT		M = MOLECULAR WEIGHT	
		R = 1545 ft-lbf/lbm-mol-R	
$\text{MASS (lbm/min)} = \frac{(\text{psia})(\text{ACFMD})(\text{lbm/lbm-mol}) \times (144 \text{ sq. in./sq. ft})}{(1545 \text{ ft-lbf/lbm-mol} \times \text{R})(\text{Temp. R})}$			
2. HEAT LOSS FROM SCC = HEAT GAINED BY AMBIENT AIR			
M(AIR,SCC) = M(AIR,STACK) - (M(AIR,AMB.))			
M(H2O,SCC) = M(H2O,STACK) - M(H2O,AMB.)			
<u>OUTLET FLOWS</u>			
M(DRY AIR) =	69.66	lb/min	
M(H2O) =	2.67	lb/min	
M(TOTAL) =	72.33	lb/min	
RESIDENCE TIME CALCULATION			

ResidenceTime Unit 2

CORRECTION FOR QUENCHED AIR AT OUTLET			
SCC DRY AIR			
$(M \times \text{ENTHALPY CHANGE})_{\text{scc}} = (M \times \text{ENTHALPY CHANGE})_{\text{amb}}$			
H(M _{scc}) =		152.5	BTU/lbm
H(M _{amb}) =		250.1	BTU/lbm
M(amb) =		0.610	x M(scc)
M(scc) + M(amb) =		69.660	lb/min
M(scc)AIR =		43.274	lb/min
SCC H2O			
$M(\text{scc})\text{H}_2\text{O} + M(\text{amb})\text{H}_2\text{O} = M(\text{outlet})\text{H}_2\text{O}$			
M(amb.) H ₂ O =		0.02	lb/lb dry air
M(amb.) AIR =		26.39	lb/min
M(amb.) H ₂ O =		0.53	lb/min
M(scc) H ₂ O =		2.14	lb/min
SCC VOLUMETRIC FLOW			
V = MRT/PM	@	1624	F
		14.77	psi
AIR:	V =	2261.3	ACFM
H2O:	V =	179.9	ACFM
TOTAL SCC:	V =	2441.2	ACFM
SCC RESIDENCE TIME			
RESIDENCE TIME =		1.75	SECONDS

Attachment E - Calibration Data

ANNUAL METER CALIBRATION		METER NO. 002047		ORIFICE SET NO. JC40-73																	
DATE	9/20/2009	Y=	0.9947	MAX % VARIATION	1.8562%	PASS															
BAROMETRIC PRESSURE	29.98	^a He=	1.7304	MAX % VARIATION	1.2487%	PASS															
CRITICAL ORIFICE DATA																					
ORIFICE SERIAL NO.	ORIFICE K' FACTOR	ACTUAL VACUUM	^a H (IN H2O)	TIME (MIN.)	AMBIENT TEMP INITIAL	AMBIENT TEMP. FINAL	METER TEMP. INITIAL	METER TEMP. FINAL	METER READING INITIAL	METER READING FINAL	VM (CU.FT.)	VM :CORRECTE	Vcr STD	Vcr NOMINAL	Y	VARIATION	^a H (IN. H2O)	VARIATION			
40	0.2435	24.0	0.31	10	83	83	82	83	719.500	722.767	3.2670	3.1872	3.1328	3.2166	0.9829	0.0015	1.7327	0.0037			
40	0.2435	24.0	0.31	10	83	83	83	84	722.767	726.050	3.2830	3.1959	3.1328	3.2166	0.9799	-0.0015	1.7295	0.0005			
40	0.2435	24.0	0.31	10	83	83	85	85	726.050	729.337	3.2870	3.1920	3.1328	3.2166	0.9814	0.0000	1.7247	-0.0042			
AVERAGE															0.9814	0.0186	1.7290	0.0008			
48	0.3557	22.5	0.66	10	84	84	86	86	730.400	735.138	4.7380	4.5966	4.5721	4.7031	0.9947	-0.0030	1.7208	0.0005			
48	0.3557	22.5	0.66	10	84	84	86	87	735.138	739.858	4.7200	4.5749	4.5721	4.7031	0.9994	0.0017	1.7193	-0.0111			
48	0.3557	22.0	0.66	10	85	85	87	87	739.858	744.580	4.7220	4.5727	4.5679	4.7074	0.9990	0.0013	1.7208	0.0005			
AVERAGE															0.9977	0.0023	1.7203	0.0058			
55	0.4616	18.5	1.15	10	86	86	88	89	745.400	751.563	6.1830	5.9783	5.9224	6.1145	0.9907	-0.0057	1.7788	0.0268			
55	0.4616	18.0	1.15	10	87	87	90	90	751.583	757.678	6.0950	5.8771	5.9170	6.1201	1.0068	0.0105	1.7772	0.0252			
55	0.4616	18.0	1.10	10	88	88	91	91	757.678	763.873	6.1950	5.9620	5.9116	6.1257	0.9916	-0.0048	1.7000	-0.0520			
AVERAGE															0.9963	0.0037	1.7520	0.0125			
63	0.5916	20.5	1.85	10	88	88	91	92	765.300	773.178	7.8780	7.5887	7.5765	7.8509	0.9984	0.0020	1.7390	0.0021			
63	0.5916	20.5	1.85	10	88	88	92	92	773.178	781.096	7.9180	7.6203	7.5765	7.8509	0.9943	-0.0021	1.7375	0.0005			
63	0.5916	20.5	1.85	10	88	88	93	93	781.096	789.010	7.9140	7.6027	7.5765	7.8509	0.9966	0.0002	1.7343	-0.0026			
AVERAGE															0.9964	0.0036	1.7369	0.0038			
73	0.8234	17.5	3.55	10	88	88	93	94	780.000	800.963	10.9630	10.5659	10.5451	10.9270	0.9980	-0.0039	1.7164	0.0026			
73	0.8234	17.5	3.55	10	88	88	94	95	800.963	811.885	10.9220	10.5074	10.5451	10.9270	1.0036	0.0017	1.7133	-0.0005			
73	0.8234	17.5	3.55	10	88	88	95	95	811.885	822.812	10.9270	10.5028	10.5451	10.9270	1.0040	0.0021	1.7116	-0.0021			
AVERAGE															1.0019	0.0019	1.7139	0.0096			
SEMI ANNUAL CALIBRATION																					
DATE		3/21/2009		BAROMETRIC PRESSURE														30.12			
ORIFICE SERIAL NO.	ORIFICE K' FACTOR	ACTUAL VACUUM	^a H (IN H2O)	TIME (MIN.)	AMBIENT TEMP INITIAL	AMBIENT TEMP. FINAL	METER TEMP. INITIAL	METER TEMP. FINAL	METER READING INITIAL	METER READING FINAL	VM (CU.FT.)	VM :CORRECTE	Vcr STD	Vcr NOMINAL	Y	VARIATION	^a H (IN. H2O)	VARIATION			
55	0.4616	21.0	1.15	10	76	75	82	81	679.000	685.182	6.1820	6.0828	6.0082	6.0555	0.9877	-0.0086	1.7590	-0.0011			
55	0.4616	21.0	1.15	10	75	75	81	80	685.182	691.342	6.1600	6.0723	6.0110	6.0526	0.9899	-0.0064	1.7606	0.0005			
55	0.4616	21.0	1.15	10	75	74	80	80	691.342	697.478	6.1360	6.0543	6.0138	6.0498	0.9933	-0.0030	1.7606	0.0005			
AVERAGE															0.9903	-0.0060	1.7600	0.0171			
																PASS		PASS			
METER COMPARISON CHECK (Y _{qa})				$Y_{qa} = (O / Vm) \times \text{sqrt}(3.19 \times Tm \times 29 / (^aHe \times (Pb + (Havg / 13.6) \times Md)) \times \text{sq} ^aH \text{ avg}$																	
Y _{qa}		Run 1	Run 2	Run 3	Average																
		0.9871	0.9884	1.0045	0.9834																
THERMOCOUPLE CALIBRATION																					
DATE		9/20/2009																			
	TC-1 (DEG F)	ASTM THERMOMETER (DEG F)																			
ICE	31	32																			
BOILING H2O	211	212																			
OIL	354	352																			
NOZZLE CALIBRATION																					
DATE		3/4/2010																			
READINGS IN (IN.)		AVERAGE																			
#24	0.750	0.750	0.751	0.7503																	
PITOT TUBE		CP=.84 ACCORDING TO DESIGN SPECIFICATIONS																			

Nozzle Calibration

Nozzle ID #24

A = 0.750

B = 0.750

C = 0.751

Average 0.7503

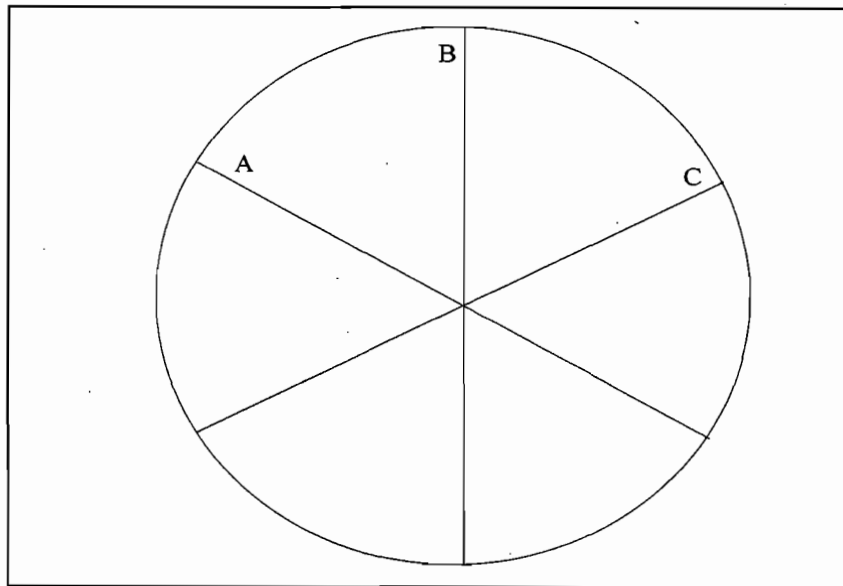

Calibration Date 3/4/2010

Calibrated by *NA*

PITOT CALIBRATION

(Type S Pitot Tube Inspection)

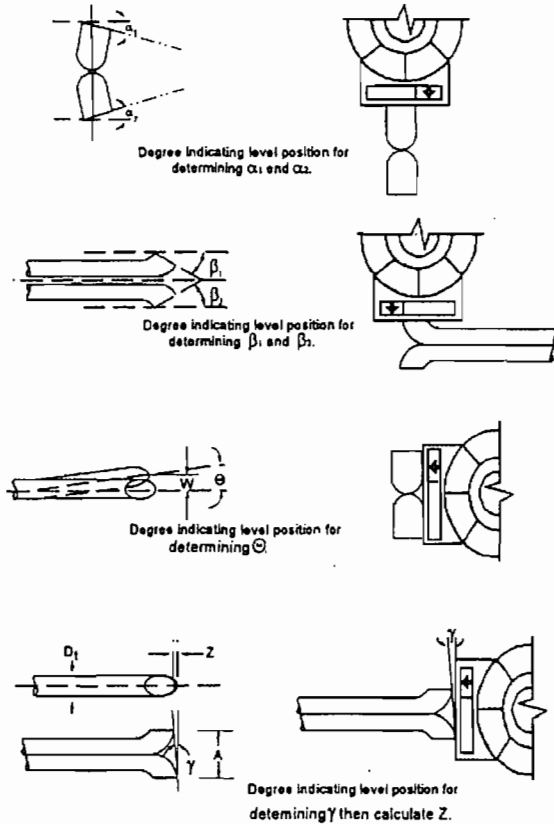

Level and Perpendicular?	Yes
Obstruction?	No
Damaged?	No
α_1 ($-10^\circ \leq \alpha_1 \leq +10^\circ$)	2
α_2 ($-10^\circ \leq \alpha_2 \leq +10^\circ$)	0
β_1 ($-5^\circ \leq \beta_1 \leq +5^\circ$)	1
β_2 ($-5^\circ \leq \beta_2 \leq +5^\circ$)	1
Y	1
θ	-2
$z = A \tan \gamma$ ($\leq 0.125^\circ$)	0.017
$w = A \tan \theta$ ($\leq 0.03125^\circ$)	-0.034
D_t ($3/16'' \leq D_t \leq +3/8''$)	0.375
A	0.961
$A/2 D_t$ ($1.05 \leq P_A / D_t \leq 1.51$)	1.281

Certification

I hereby certify that type S pitot tube ID# P-5AC meets or exceeds all specifications, criteria and applicable design features, and is hereby assigned a pitot tube calibration factor of 0.84.

Certified by: *[Signature]*

Date: 9/20/09

Guiding Light Cremations, LLC

DATE: 3/3/2010
 RUN: 1
 UNIT: 2

AVG. ADJUSTED CO ppmvd @ 7% O2	0.79
CORRECTED O2 %	13.43
CORRECTED CO2 %	5.14
CORRECTED CO ppmvd	0.42

ANALYZER RESPONSE, SYSTEM BIAS AND SYSTEM DRIFT DATA

RANGE SETTING	CAL GASES	CERTIFIED GAS VALUE	ANALYZER VALUE	DIFFERENCE PPM	% SPAN	ANALYZER PRETEST VALUE	% SPAN	ANALYZER POSTTEST VALUE	% SPAN	% DRIFT	ANALYZER SERIAL #
25	% O2	0.00	0.00	0.00	0.00	0.00	0.00	0.00	0.00	0.00	01420B153
		12.04	12.00	-0.04	-0.18	12.00	0.00	12.00	0.00	0.00	
		22.62	22.50	-0.12	-0.53						
20	% CO2	0.00	0.00	0.00	0.00	0.00	0.00	0.00	0.00	0.00	01410B139
		9.62	9.60	-0.02	-0.12	9.60	0.00	9.60	0.00	0.00	
		17.27	17.30	0.03	0.17						
100	PPM CO	0.00	0.00	0.00	0.0	0.00	0.0	0.00	0.0	0.0	48C-68845-381
		48.5	48.4	-0.10	-0.1	48.30	-0.1	48.20	-0.2	-0.1	
		102.00	102.90	0.90	0.9						

UNCORRECTED RAW DATA

DATE & TIME	O2 %	CO2 %	CO PPM
16:20	12.78	6.17	0.70
16:21	12.53	5.92	0.60
16:22	13.07	5.18	0.60
16:23	13.48	5.00	0.65
16:24	13.45	5.04	0.50
16:25	13.34	5.10	0.60
16:26	13.28	5.12	0.45
16:27	13.28	5.05	0.55
16:28	13.39	4.93	0.50
16:29	13.61	4.76	0.45
16:30	13.66	4.65	0.45
16:31	13.96	4.67	0.30
16:32	13.78	4.82	0.35
16:33	13.51	4.95	0.30
16:34	13.43	4.95	0.55
16:35	13.63	4.84	0.85
16:36	13.91	4.72	0.80
16:37	13.98	4.80	0.50
16:38	13.68	5.00	0.45
16:39	13.46	5.04	0.50
16:40	13.52	4.94	0.80
16:41	13.82	4.78	0.80
16:42	13.91	4.84	0.75
16:43	13.66	4.93	0.75
16:44	13.63	4.91	0.90
16:45	13.78	4.77	1.00
16:46	13.97	4.73	0.90
16:47	13.92	4.88	0.55
16:48	13.23	5.44	0.80
16:49	12.81	5.31	0.85
16:50	13.48	4.94	0.70
16:51	13.68	5.10	0.75
16:52	13.10	5.17	1.00
16:53	13.49	5.07	0.80
16:54	13.46	4.97	0.20
16:55	13.76	4.89	0.10
16:56	13.49	5.19	0.10
16:57	12.91	5.39	0.15
16:58	13.13	5.02	0.20
16:59	13.91	4.69	0.05
17:00	13.82	5.05	0.15
17:01	13.01	5.39	0.15
17:02	12.96	5.31	0.20
17:03	13.01	5.49	0.20
17:04	13.25	5.39	0.25
17:05	13.14	5.61	0.20
17:06	12.69	5.69	0.30
17:07	12.75	5.51	0.30
17:08	13.31	5.19	0.20
17:09	13.48	5.32	0.15
17:10	12.92	5.57	0.25
17:11	12.84	5.42	0.25
17:12	13.41	5.06	0.05
17:13	13.63	5.18	0.00
17:14	13.03	5.52	0.05
17:15	12.77	5.48	0.25
17:16	13.20	5.13	0.15
17:17	13.73	4.95	0.00
17:18	13.40	5.34	0.05
17:19	12.73	5.55	0.15

MEAN ANALYZER VALUES

Avg. % O2	13.39
Avg. % CO2	5.13
Avg. CO ppmvd	0.42

Guiding Light Cremations, LLC

DATE: 3/4/2010
 RUN: 2
 UNIT: 2

AVG. ADJUSTED CO ppmvd @ 7% O2	1.04
CORRECTED O2 %	13.79
CORRECTED CO2 %	4.46
CORRECTED CO ppmvd	0.53

ANALYZER RESPONSE, SYSTEM BIAS AND SYSTEM DRIFT DATA

RANGE SETTING	CAL GASES	CERTIFIED GAS VALUE	ANALYZER VALUE	DIFFERENCE PPM	% SPAN	ANALYZER PRETEST VALUE	% SPAN	ANALYZER POSTTEST VALUE	% SPAN	% DRIFT	ANALYZER SERIAL #
25	% O2	0.00	0.00	0.00	0.00	0.00	0.00	0.00	0.00	0.00	01420B153
		12.04	12.00	-0.04	-0.18	12.00	0.00	11.90	-0.44	-0.44	
		22.62	22.50	-0.12	-0.53						
20	% CO2	0.00	0.00	0.00	0.00	0.10	0.58	0.00	0.00	-0.58	01410/B139
		9.62	9.60	-0.02	-0.12	9.60	0.00	9.60	0.00	0.00	
		17.27	17.30	0.03	0.17						
50	PPM CO	0.00	0.00	0.00	0.0	0.10	0.1	0.00	0.0	-0.1	48C-68845-361
		48.50	48.40	-0.10	-0.1	48.60	0.2	48.10	-0.3	-0.5	
		102.00	102.90	0.90	0.9						

UNCORRECTED RAW DATA

DATE & TIME	O2 %	CO2 %	CO PPM
9:30	11.82	7.41	0.60
9:31	10.44	7.54	1.15
9:32	11.59	5.91	1.25
9:33	13.23	4.97	1.20
9:34	13.35	5.06	0.90
9:35	13.06	5.06	0.65
9:36	13.03	5.04	0.50
9:37	13.14	4.89	0.45
9:38	13.28	4.78	0.45
9:39	13.40	4.67	0.45
9:40	13.50	4.60	0.45
9:41	13.56	4.54	0.40
9:42	13.63	4.49	0.40
9:43	13.71	4.41	0.40
9:44	13.79	4.36	0.40
9:45	13.78	4.38	0.45
9:46	13.77	4.36	0.40
9:47	13.80	4.34	0.45
9:48	13.83	4.32	0.30
9:49	13.83	4.29	0.30
9:50	13.85	4.27	0.30
9:51	13.88	4.23	0.25
9:52	13.93	4.18	0.25
9:53	13.99	4.13	0.25
9:54	14.00	4.12	0.25
9:55	14.04	4.09	0.30
9:56	14.04	4.09	0.30
9:57	14.07	4.06	0.25
9:58	14.09	4.06	0.20
9:59	13.85	4.49	0.15
10:00	13.06	4.88	0.25
10:01	12.97	4.55	0.35
10:02	14.02	4.17	1.25
10:03	14.04	4.13	0.85
10:04	14.08	4.14	0.70
10:05	14.01	4.19	0.75
10:06	13.98	4.20	0.80
10:07	13.94	4.26	0.80
10:08	13.93	4.23	0.80
10:09	13.94	4.22	0.70
10:10	13.98	4.19	0.80
10:11	14.03	4.14	0.75
10:12	14.06	4.12	0.70
10:13	14.09	4.10	0.70
10:14	14.13	4.10	0.70
10:15	14.16	4.07	0.75
10:16	14.19	4.07	0.70
10:17	14.17	4.08	0.70
10:18	14.15	4.09	0.65
10:19	14.16	4.11	0.65
10:20	14.11	4.14	0.65
10:21	14.09	4.16	0.60
10:22	14.06	4.18	0.60
10:23	14.05	4.19	0.65
10:24	14.02	4.24	0.65
10:25	13.92	4.35	0.70
10:26	13.79	4.44	0.70
10:27	13.69	4.53	0.65
10:28	13.56	4.64	0.65
10:29	13.39	4.80	0.65

MEAN ANALYZER VALUES

Avg. % O2	13.68
Avg. % CO2	4.48
Avg. CO ppmvd	0.58

Guiding Light Cremations, LLC

DATE: 3/4/2010
 RUN: 3
 UNIT: 2

AVG. ADJUSTED CO ppmvd @ 7% O2	0.74
CORRECTED O2 %	13.23
CORRECTED CO2 %	5.03
CORRECTED CO ppmvd	0.41

ANALYZER RESPONSE, SYSTEM BIAS AND SYSTEM DRIFT DATA

RANGE SETTING	CAL GASES	CERTIFIED GAS VALUE	ANALYZER VALUE	DIFFERENCE PPM	% SPAN	ANALYZER PRETEST VALUE	% SPAN	ANALYZER POSTTEST VALUE	% SPAN	% DRIFT	ANALYZER SERIAL #
25	% O2	0.00	0.00	0.00	0.00	0.00	0.00	0.00	0.00	0.00	01420B153
		12.04	12.00	-0.04	-0.18	11.90	-0.44	11.90	-0.44	0.00	
		22.62	22.50	-0.12	-0.53						
20	% CO2	0.00	0.00	0.00	0.00	0.00	0.00	0.00	0.00	0.00	01410B139
		9.62	9.60	-0.02	-0.12	9.80	0.00	9.60	0.00	0.00	
		17.27	17.30	0.03	0.17						
50	PPM CO	0.00	0.00	0.00	0.0	0.00	0.0	0.00	0.0	0.0	48C-68845-361
		48.50	48.40	-0.10	-0.1	48.10	-0.3	47.80	-0.6	-0.3	
		102.00	102.90	0.90	0.9						

UNCORRECTED RAW DATA

DATE & TIME	O2 %	CO2 %	CO PPM
11:00	16.14	3.07	1.30
11:01	15.99	3.06	0.60
11:02	16.01	3.18	0.50
11:03	15.08	3.89	0.35
11:04	14.37	4.14	0.40
11:05	14.06	4.44	0.45
11:06	13.64	4.76	0.45
11:07	13.22	5.12	0.55
11:08	12.91	5.26	0.65
11:09	12.80	5.34	0.75
11:10	12.73	5.37	0.80
11:11	12.68	5.41	0.75
11:12	12.64	5.40	0.85
11:13	12.64	5.41	0.85
11:14	12.59	5.44	0.95
11:15	12.58	5.44	0.95
11:16	12.68	5.33	1.00
11:17	12.91	5.13	0.90
11:18	13.41	4.83	0.75
11:19	13.66	4.86	0.65
11:20	13.33	5.10	0.75
11:21	13.09	5.13	0.70
11:22	13.13	5.03	0.85
11:23	13.24	4.98	0.65
11:24	13.26	4.99	0.60
11:25	13.28	4.94	0.65
11:26	13.36	4.89	0.60
11:27	13.41	4.88	0.65
11:28	13.41	4.84	1.30
11:29	13.71	4.84	0.85
11:30	12.43	5.59	0.15
11:31	12.17	5.56	0.05
11:32	12.19	5.57	0.05
11:33	12.20	5.52	0.05
11:34	12.26	5.48	0.05
11:35	12.29	5.47	0.05
11:36	12.30	5.44	0.10
11:37	12.35	5.41	0.05
11:38	12.38	5.38	0.05
11:39	12.42	5.36	0.05
11:40	12.43	5.36	0.20
11:41	12.46	5.31	0.10
11:42	12.54	5.28	0.10
11:43	12.54	5.28	0.10
11:44	12.58	5.24	0.10
11:45	12.58	5.28	0.10
11:46	12.59	5.23	0.10
11:47	12.63	5.22	0.10
11:48	12.65	5.17	0.15
11:49	12.74	5.13	0.15
11:50	12.78	5.10	0.05
11:51	12.83	5.08	0.05
11:52	12.85	5.06	0.05
11:53	12.90	5.03	0.05
11:54	12.96	4.98	0.05
11:55	13.02	4.93	0.05
11:56	13.08	4.92	0.10
11:57	13.09	4.90	0.10
11:58	13.12	4.88	0.05
11:59	13.21	4.77	0.00

MEAN ANALYZER VALUES

Avg. % O2	13.07
Avg. % CO2	5.02
Avg. CO ppmvd	0.40

Liquid Technology Corporation

Industry Leader in Specialty Gases, Equipment and Service

Certificate of Analysis

- EPA PROTOCOL GAS -

Customer Coastal Air Consulting (Deland, Florida)
Date December 08, 2009
Delivery Receipt DR-26962
Gas Standard 9.00-10.0% CO₂, 11.5-12.5% Oxygen/Nitrogen-EPA PROTOCOL
Final Analysis Date December 08, 2009
Expiration Date December 08, 2012

Component Carbon Dioxide, Oxygen
Balance Gas Nitrogen

Analytical Data: **DO NOT USE BELOW 150 psig**
EPA Protocol, Section No. 2.2, Procedure G-1

Reported Concentrations

Carbon Dioxide: 9.62% +/- 0.09%

Oxygen: 12.04% +/- 0.12%

Nitrogen: Balance

Reference Standards:

SRM/GMIS:	GMIS/GMIS	GMIS/GMIS
Cylinder Number:	CC-159026/CC-165377	CC-231332/CC-85458
Concentration:	5.14% CO ₂ /N ₂ -10.05% CO ₂ /Nitrogen	10.1% O ₂ /N ₂ - 20.97% Oxygen/N ₂
Expiration Date:	03/31/11 - 04/06/11	03/04/11 - 04/15/11

Certification Instrumentation

Component:	Carbon Dioxide	Oxygen
Make/Model:	Agilent 7890A	Servomex 244a
Serial Number:	CN10736166	1847
Principal of Measurement:	GC-TCD	Paramagnetic
Last Calibration:	December 05, 2009	November 20, 2009

Cylinder Data

Cylinder Serial Number: EB-0020405 Cylinder Outlet: CGA 590
Cylinder Volume: 140 Cubic Feet Cylinder Pressure: 2000 psig, 70°F
Analytical Uncertainty and NIST Traceability are in compliance with EPA-600/R-97/121.

Certified by:



Mike Duncan

Unmatched Excellence

Liquid Technology Corporation

Industry Leader in Specialty Gases, Equipment and Service

Certificate of Analysis **- EPA PROTOCOL GAS -**

Customer Coastal Air Consulting (Deland, Florida)
Date November 14, 2008
Delivery Receipt DR-23098
Gas Standard 17.0-18.0% CO₂; 22.0-23.0% Oxygen/Nitrogen-EPA PROTOCOL
Final Analysis Date November 14, 2008
Expiration Date November 14, 2011

Component Carbon Dioxide, Oxygen
Balance Gas Nitrogen

Analytical Data: **DO NOT USE BELOW 150 psig**
EPA Protocol, Section No. 2.2, Procedure G-1

Reported Concentrations
Carbon Dioxide: 17.27% +/- 0.17%
Oxygen: 22.62% +/- 0.22%
Nitrogen: Balance

Reference Standards:

SRM/GMIS:	GMIS	GMIS/GMIS
Cylinder Number:	CC-79616	CC-125554/CC-85469
Concentration:	17.4% CO ₂ /Nitrogen	20.99% O ₂ /N ₂ - 25.30% Oxygen/N ₂
Expiration Date:	12/01/12	04/02/11 - 08/09/10

Certification Instrumentation

Component:	Carbon Dioxide	Oxygen
Make/Model:	Hewlett Packard 5890 II	Servomex 244a
Serial Number:	3336A59393	1847
Principal of Measurement:	TCD	Paramagnetic
Last Calibration:	November 05, 2008	November 10, 2008

Cylinder Data

Cylinder Serial Number:	CC-231467	Cylinder Outlet:	CGA 590
Cylinder Volume:	140 Cubic Feet	Cylinder Pressure:	2000 psig, 70°F

Analytical Uncertainty and NIST Traceability are in compliance with EPA-600/R-97/121.

Certified by: 
Date: November 14, 2008

Unmatched Excellence

Liquid Technology Corporation

Industry Leader in Specialty Gases, Equipment and Service

Certificate of Analysis

- EPA PROTOCOL GAS -

Customer Coastal Air Consulting (Deland, Florida)
Date July 22, 2009
Delivery Receipt DR-25422
Gas Standard 11-13 ppm Nitric Oxide, 23-27 ppm Carbon Monoxide/Nitrogen
Final Analysis Date July 22, 2009
Expiration Date July 22, 2011 **DO NOT USE BELOW 150 psig**

Analytical Data:

EPA Protocol, Section No. 2.2, Procedure G-1.

Reported Concentrations:

Nitric Oxide: 11.8 ppm +/- 0.11 ppm
Carbon Monoxide: 25.7 ppm +/- 0.25 ppm
Nitrogen: Balance
Total NOx: 11.8 ppm

** Total NOx for Reference Use Only **

Reference Standards

<u>SRM/GMIS</u>	<u>GMIS/GMIS</u>	<u>GMIS/GMIS</u>
Cylinder Number:	CC-165557/CC-117924	CC-184197/CC-158976
Concentration:	5.22 ppm NO/19.48 ppm NO	10.07 ppm CO/25.1 ppm CO
Expiration Date:	12/03/10 - 12/11/10	06/15/10 - 08/04/10

Certification Instrumentation

Component:	Nitric Oxide	Carbon Monoxide
Make/Model:	Nicolet NEXUS 470	Nicolet-NEXUS 470
Serial Number:	AEP99000154	AEP99000154
Principal of Measurement:	FTIR	FTIR
Last Calibration:	July 04, 2009	July 02, 2009

Cylinder Data

Cylinder Number:	EB-0016054	Cylinder Volume:	140 Cubic Feet
Cylinder Outlet:	CGA 660	Cylinder Pressure:	2000 psig, 70°F
Expiration Date:	July 22, 2011		

Analytical Uncertainty and NIST Traceability are in compliance with EPA-600/R-97/121.

Certified by:

Mike Duncan

Unmatched Excellence

Liquid Technology Corporation

Industry Leader in Specialty Gases, Equipment and Service

Certificate of Analysis

- EPA PROTOCOL GAS -

Customer Coastal Air Consulting (Deland, Florida)
Date October 27, 2009
Delivery Receipt DR-26491
Gas Standard 22-25 ppm NO, 45-50 ppm CO/Nitrogen - EPA PROTOCOL
Final Analysis Date October 20, 2009
Expiration Date October 20, 2011

Components Nitric Oxide, Carbon Monoxide
Balance Gas Nitrogen

Analytical Data: DO NOT USE BELOW 150 psig
EPA Protocol, Section No. 2.2, Procedure G-1

Reported Concentrations

Nitric Oxide: 22.9 ppm +/- 0.22 ppm
Carbon Monoxide: 48.5 ppm +/- 0.48 ppm
Nitrogen: Balance
Total Oxides of Nitrogen: 23.5 ppm

** Total NOX for Reference Use Only **

Reference Standards:

SRM/GMIS:	GMIS	GMIS/GMIS
Cylinder Number:	CC-231538	CC-125604/CC-166617
Concentration:	24.41 ppm NO	25.5 ppm CO/51.0 ppm CO
Expiration Date:	06/24/11	02/27/10 - 09/18/10

Certification Instrumentation

Component:	Nitric Oxide	Carbon Monoxide
Make/Model:	Nicolet-NEXUS 470	Nicolet-NEXUS 470
Serial Number:	AEP99000154	AEP99000154
Principal of Measurement:	FTIR	FTIR
Last Calibration:	October 05, 2009	October 06, 2009

Cylinder Data

Cylinder Serial Number:	CC-233289	Cylinder Outlet:	CGA 660
Cylinder Volume:	140 Cubic Feet	Cylinder Pressure:	2000 psig; 70°F

Analytical Uncertainty and NIST Traceability are in compliance with EPA-600/R-97/121.

Certified by:



Mike Duncan

Unmatched Excellence

Liquid Technology Corporation

Industry Leader in Specialty Gases, Equipment and Service

Certificate of Analysis

- EPA PROTOCOL GAS -

Customer Coastal Air Consulting (Deland, Florida)
Date July 22, 2009
Delivery Receipt DR-25422
Gas Standard 100.0 ppm Carbon Monoxide/Nitrogen - EPA PROTOCOL
Final Analysis Date July 22, 2009
Expiration Date July 22, 2012

Component Carbon Monoxide
Balance Gas Nitrogen

Analytical Data: **DO NOT USE BELOW 150 psig**
EPA Protocol, Section No. 2.2, Procedure G-1

Replicate Concentrations

Carbon Monoxide: 102.0 ppm +/- 1.0 ppm

Nitrogen: Balance

Reference Standards:

SRM/GMIS: GMIS
Cylinder Number: CC-233156
Concentration: 104.91 ppm CO/Nitrogen
Expiration Date April 16, 2011

Certification Instrumentation

Component: Carbon Monoxide
Make/Model: Nicolet - NEXUS 470
Serial Number: AEP99000154
Principal of Measurement: FTIR
Last Calibration: July 02, 2009

Cylinder Data

Cylinder Serial Number: CC-233184 Cylinder Outlet: CGA 350
Cylinder Volume: 140 Cubic Feet Cylinder Pressure: 2000 psig, 70°F
Analytical Uncertainty and NIST Traceability are in compliance with EPA-600/R-97/121.

Certified by:



Mike Duncan

Unmatched Excellence

Attachment F - Project Participants

Project Participants

Arlington Environmental Services, Inc.

William Arlington
Project Director

Rufus Rhoden
Field Technician

Kaye Arlington
Laboratory Analyst

Debra Carter
Computer Analysis

Coastal Air Consultants, Inc

Stephen Webb

Guiding Light Cremations, Unit 2

Geronimo Mena
Facility Manager

Broward County Environmental Management

Courtney Pitters
Inspector

Attachment 2
Equipment Drawings and Brochures

The "Classic" Cremator

PERFORMANCE BEYOND EXPECTATIONS

BUILT to exacting quality and safety standards and backed by a two-year limited warranty, the fuel efficient "Classic" outperforms every other cremator in its price range. Take a look at some of the performance benefits the "Classic" offers!

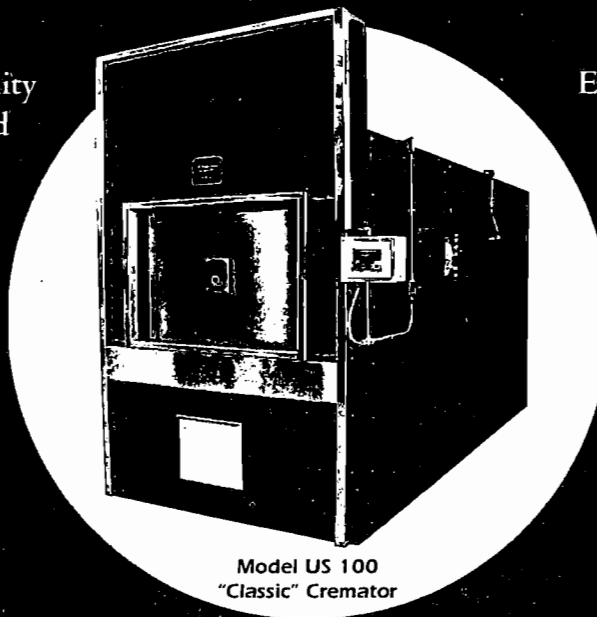

Model US 100
"Classic" Cremator

Exceptional standard features combine with professional expertise to deliver the product and service you demand. Unsurpassed in customer support, you can rely on U. S. Cremation Equipment's "Classic" to provide years of trouble-free operation.

CLASSIC PERFORMANCE

- Cremate up to six bodies in a 10-hour work day
- Complete cremation every 60 - 90 minutes
- No cool down required between cremations
- Designed to cremate obese cases up to 800 lbs.
- Fully automatic PLC operating system

CLASSIC FEATURES

- Power charging door // dual hydraulic cylinders
- Primary chamber viewport
- Secondary chamber temperature recorder
- Color touch screen control - standard
- Powder coat finish with stainless steel trim



370 S. North Lake Boulevard, Suite 1004 • Altamonte Springs, FL 32701 • Ph: 321.282.7357 • Fax: 321.282.7358
www.uscremationequipment.com • E-mail: info@uscremationequipment.com

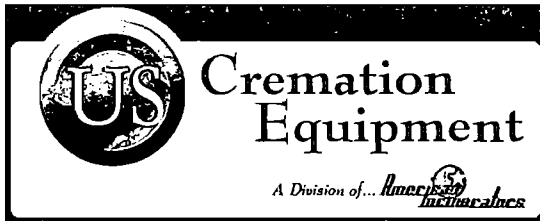

HUMAN CREMATION CHAMBER SPECIFICATION

EQUIPMENT:

US Cremation Equipment a division of American Incinerators Co. - Multiple Chambered human Crematory, Natural Gas, Propane (LP) or Oil fired.

MANUFACTURER:

US Cremation Equipment a division of American Incinerators Corp.

CONSTRUCTION STANDARDS:

The American Incinerators cremation chamber shall be constructed of U.L./CSA listed components and will meet or exceed nationally accepted incinerator construction standards per the Incinerator Institute of America (IIA) publication guidelines; i.e.:

- A. Primary chamber will not exceed 60% of total furnace volumes. Flue connection shall not be considered part of furnace volume.
- B. Flame supervision through continuous ultraviolet scanning flame detectors on all burners.
- C. High temperature refractory construction with air-cooled walls to prevent excessive heat radiation.
- D. Exhaust gas temperature reduction.

INCINERATION CHAMBER DIMENSIONS:

Chamber volumes:	Primary - 73 CF Secondary - 71 CF
Structural footprint:	12'0" (L) x 5'0" (W)
Over-all dimensions:	12'7" (L) x 6'0" (W) x 9'2" (H) w/std. hyd. door

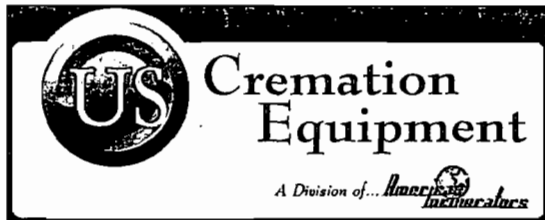

OPERATING TEMPERATURE:

Temperatures are determined as a result of federal, state or local permitting authority operating standards.

Typical primary chamber setting: 1,000°F-1,200°F
Typical secondary chamber setting: 1,400°F-1,800°F

RETENTION TIME:

In excess of 1 second.

CAPACITY:

One body and associated container per cremation cycle. 200 pounds per hour or 750 pounds per batch.

DRAFT:

Induced via refractory lined draft inducer.

SHIPPING WEIGHT:

24,500 lbs.

EMISSIONS:

The American Incinerators cremation chamber shall meet or exceed federal, state and local environmental regulations.

EMISSION CONTROL:

Secondary chamber equipped with one, 1,500,000 BTU/HR burner. Also equipped with an electronic exhaust gas scanner system which temporarily suspends operation of the primary chamber burner.

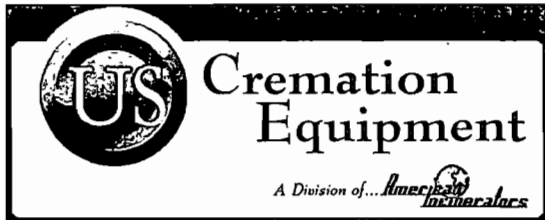

STEEL CONSTRUCTION SPECIFICATIONS:

- A. The structure to be heavy 3" steel angle , square tube; 3/8" steel plate, seal welded construction.
- B. Subfloors to be 3/16" steel plate, seal welded construction.
- C. The exterior shell to be 12 gauge steel removable panels.
- D. Interior shell to be 10 gauge steel, seal welded construction.

INSULATION & REFRACTORY SPECIFICATIONS:

- A. Hot Hearth: 3000°F abrasion resistant castable refractory, monolithic cast 7" - 13" thick, 1 -1/2" recessed top and rounded, stressed arched bottom.
- B. Chamber Floors: 3000°F abrasion resistant castable refractory, 5" thick on top of 2" 2400°F light weight insulating castable.
- C. Chamber Ceilings: 3000°F castable refractory, monolithic cast, rounded, stressed arched, 5"-9" thick, topped by 2" 2400°F light weight insulating castable.
- D. Interior Walls: 2800°F. alumina-silicate firebrick, 2 1/2" x 4 1/2" x 9", all chambers are backed by 4" of 1900°F ceramic fiber insulation
- E. Stack: Lined with 2" of 2200°F insulating refractory.

SKIN TEMPERATURE CONTROL:

Integral dual casing, completely air-cooled design to prevent excessive heat radiation.

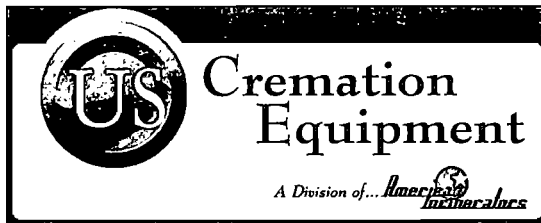

COMBUSTION EQUIPMENT:

- A. Combustion Air - One, 3 phase, 208-230/460V, 17-15.5/7.6 amp 7 hp air-blower motor (1,400 CFM)
- B. Primary Chamber - One 500,000 BTU/HR nozzle mix, gas-fired burner. Eclipse, North American, or equal.
- C. Secondary Chamber - One, 1,500,000 BTU/HR modulating, nozzle mix, gas-fired burner. Eclipse, North American, or equal.
- D. Burner Flame Safeguard - Control supervision on each burner via a flame safeguard relay and ultra-violet light detector.
- E. Low Air Pressure Safety Switch - Interlocked to all burners.

EXHAUST GAS TEMPERATURE REDUCTION:

Hot air duct operating exit temperature: 900°F

HOT AIR DUCT:

10 gauge carbon steel, high temperature 2" refractory lining, pre-drilled flanges, 24" Outside Diameter, 28" at flanges.

UTILITY REQUIREMENTS:

A. GAS:

- 1. Pressure:
 - a) Natural Gas: 7" to 9" W.C.
 - b) Propane: 11" W.C.
- 2. Flow Rate: 2,000,000 BTU/HR

B. ELECTRICAL:

- 1. One, three phase, 208-230/460V, 17-15/8 amp connection for 5hp blower.

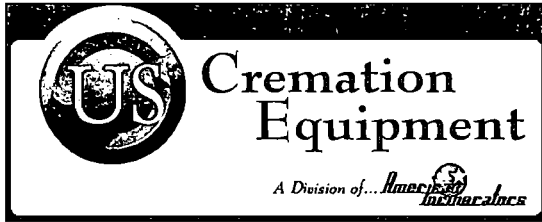

CREMATION CHAMBER LOADING/CLEAN-OUT DOOR:

Hydraulically operated, refractory lined, upward movement guillotine style door with gate view port.

CREMATION PROCESS CONTROL:

The cremation cycle is controlled by a programmable logic control (PLC) system. A visual confirmation of the system status is provided through control panel indicator lights and digital temperature display. Continuous fuel and air modulation is automatically controlled by a time/temperature actuated system. Operator interface is through two sets of simple push button controls and panel timer.

EXTERIOR FINISH:

The cremation chamber is finished with grey hi-resistance powder coating with stainless steel trim. Back of unit is coated with an epoxy type black coating.

Attachment 2
Emissions Calculations

US Cremation Equipment
Model "Classic"

Pounds Incinerated Per Hour (Average)	Hours Per Year	SO2 lb/ton	SO2 lb/hr	SO2 TPY	Nox lb/ton	Nox lb/hr	Nox TPY	TOC lb/ton	TOC lb/hr	TOC TPY
200	8760	2.5	0.25	1.095	3	0.3	1.314	3	0.3	1.314

CO=100 PPM @ 7% O2 MAX, Actual CO Emissions Measured at 3.49 PPM
 CO = 100 PPM X 28 MW X 1700 DSCFM X 2.595E-09 X 60 min/hr = 0.74 lb/hr CO
 0.74 lb/hr CO X 8760 hrs/yr X 1 ton/2000 lb = 3.24 TPY CO

Actual Emissions were measured at 0.04 gr/dscfm at 7% O2
 PM = 0.08 gr/dscf X 1 pound/7000 gr X 1700 DSCFM X 60 min/hr = 1.17 lb/hr PM
 1.17 lb/hr PM X 8760 hrs/yr X 1 ton/2000 lb = 5.12 TPY PM

Attachment 4
Process Flow Diagram

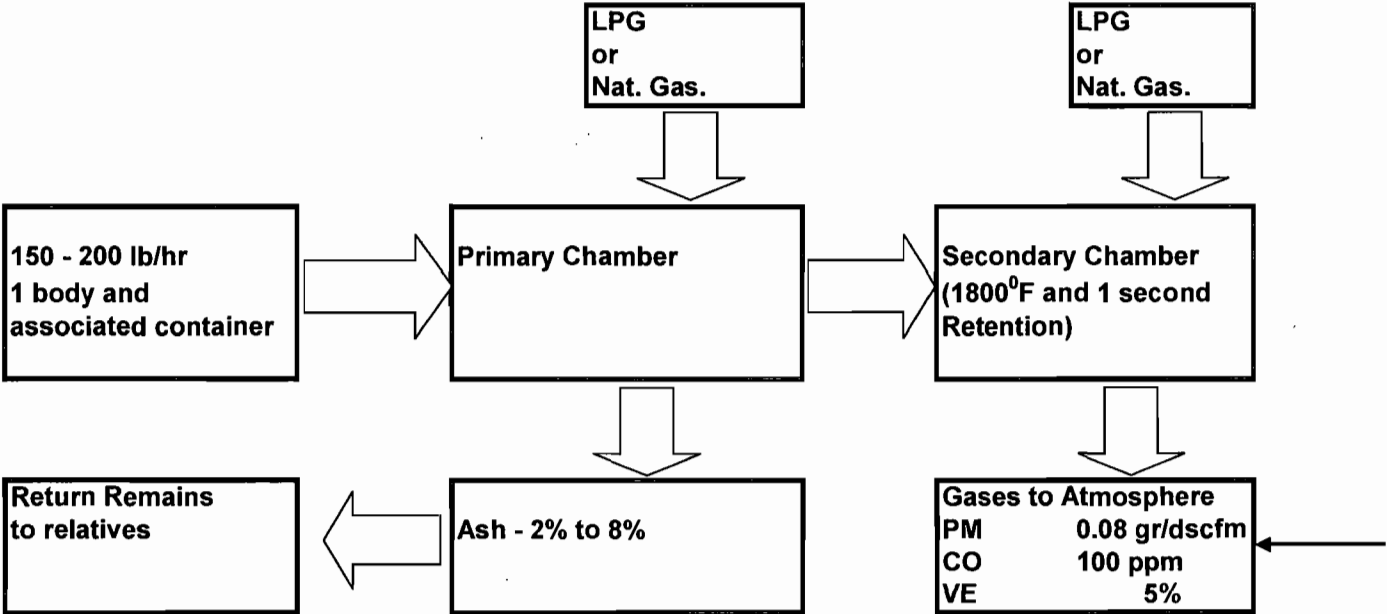

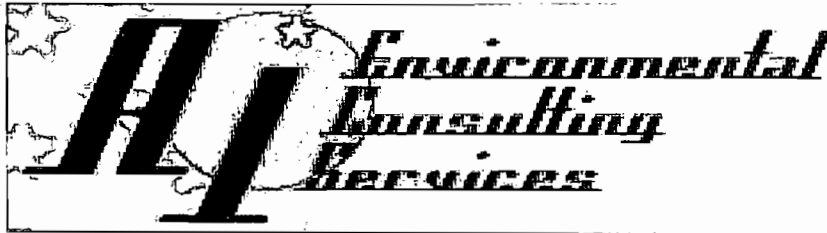

***General Permit Application
Human Crematory***

***Prepared for:
Atlas Crematory
2111 South U.S. Highway 1
Rockledge, FL 32955
Brevard County
AIRS ID# 0090054-005-AG***

Prepared By:

***AI Environmental Consulting Services, Inc.
598 Northlake Blvd, Ste. 1016
Altamonte Springs, Florida 32701***

Date: March 2011

Application Contents

Form 62-210.920(2)(c) General Permit Application
Attachment 1 - Compliance Test Report
Attachment 2 - Equipment Drawings and Brochures
Attachment 3 - AP-42 Emissions Calculations
Attachment 4 - Process Flow Diagram

Beckman-Williamson Funeral Home
5400 Village Drive
Viera, Florida 32855



Florida Department of Environmental Protection
FDEP Receipts
P.O Box 3070
Tallahassee, Florida 32315-3070

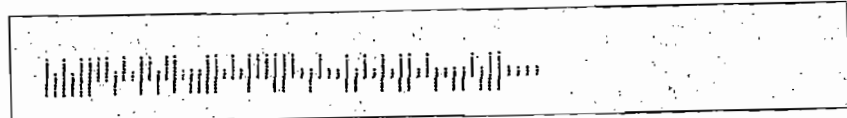

**RETURN RECEIPT
REQUESTED**