

511607 SEP 2 2010
RECEIVED

HUMAN CREMATORY
AIR GENERAL PERMIT REGISTRATION FORM

SEP 03 2010

Bureau of Air Monitoring
& Mobile Sources

Part II. Notification to Permitting Office

(Detach and submit to appropriate permitting office; keep copy onsite)

Instructions: To give notice to the Department of an eligible facility's intent to use this air general permit, the owner or operator of the facility must detach and complete this part of the Air General Permit Registration Form and submit it to the appropriate Department of Environmental Protection or local air pollution control program office which has permitting authority. Please type or print clearly all information, and enclose the appropriate air general permit registration processing fee pursuant to Rule 62-4.050(4)(o), F.A.C. (\$100 as of the effective date of this form)

0990694-001

Registration Type

Check one:

INITIAL REGISTRATION - Notification of intent to:

- Construct and operate a proposed new facility.
- Operate an existing facility not currently using an air general permit (e.g., a facility proposing to go from an air operation permit to an air general permit).

RE-REGISTRATION (for facilities currently using an air general permit) - Notification of intent to:

- Continue operating the facility after expiration of the current term of air general permit use.
- Continue operating the facility after a change of ownership.
- Make an equipment change requiring re-registration pursuant to Rule 62-210.310(2)(e), F.A.C., or any other change not considered an administrative correction under Rule 62-210.310(2)(d), F.A.C.

Surrender of Existing Air Operation Permit(s) - For Initial Registrations Only

If the facility currently holds one or more air operation permits, such permit(s) must be surrendered by the owner or operator upon the effective date of this air general permit. In such case, check the first box, and indicate the operation permits being surrendered. If no air operation permits are held by the facility, check the second box.

- All existing air operation permits for this facility are hereby surrendered upon the effective date of this air general permit; specifically permit number(s): _____
- No air operation permits currently exist for this facility.

General Facility Information

Facility Owner/Company Name (Name of corporation, agency, or individual owner who or which owns, leases, operates, controls, or supervises the facility.)

LORNE & SON'S INC. 745 NE 6 AVENUE, DELRAY BEACH FL 33483

Site Name (Name, if any, of the facility site; e.g., Plant A, Metropolis Plant, etc. If more than one facility is owned, a registration form must be completed for each.)

Facility Location (Provide the physical location of the facility, not necessarily the mailing address.)

Street Address:

City:

DeLray Beach

County:

Palm Beach

Zip Code:

33483-5701

Facility Start-Up Date (Estimated start-up date of proposed new facility.) (N/A for existing facility)

February 2011

Owner/Authorized Representative

| | | |
|--|--|--|
| <u>Name and Position Title</u> (Person who, by signing this form below, certifies that the facility is eligible to use this air general permit.) Print Name and Title: PATRICK D. LORNE VICE PRESIDENT | | |
| <u>Owner/Authorized Representative Mailing Address</u> Organization/Firm: LORNE & SONS FUNERAL HOME Street Address: 745 NE 6th AVENUE City: Delray Beach County: Palm Beach Zip Code: 33483-5701 | | |
| <u>Owner/Authorized Representative Telephone Numbers</u> Telephone: 561-276-4161 Fax: 561-276-9288 Cell phone (optional): 561-573-3657 | | |

Facility Contact (If different from Owner/Authorized Representative)

| | | |
|---|--|--|
| <u>Name and Position Title</u> (Plant manager or person to be contacted regarding day-to-day operations at the facility.) Print Name and Title: | | |
| <u>Facility Contact Mailing Address</u> Organization/Firm: Street Address: City: County: Zip Code: | | |
| <u>Facility Contact Telephone Numbers</u> Telephone: Fax: Cell phone (optional): | | |

Owner/Authorized Representative Statement

This statement must be signed and dated by the person named above as owner or authorized representative

I, the undersigned, am the owner or authorized representative of the owner or operator of the facility addressed in this Air General Permit Registration Form. I hereby certify, based on information and belief formed after reasonable inquiry, that the facility addressed in this registration form is eligible for use of this air general permit and that the statements made in this registration form are true, accurate and complete. Further, I agree to operate and maintain the facility described in this registration form so as to comply with all applicable standards for control of air pollutant emissions found in the statutes of the State of Florida and rules of the Department of Environmental Protection and revisions thereof.

I will promptly notify the Department of any changes to the information contained in this registration form.

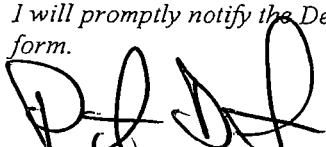
 _____
Signature

8/26/2010
Date

Design Calculations

If this is an initial registration for a proposed new human crematory unit, provide design calculations to confirm a sufficient volume in the secondary chamber combustion zone to provide for at least a 1.0 second gas residence time at 1800 degrees F.

- Manufacturer's' design calculations attached.
- Registration is not for proposed new human crematory unit(s).

Description of Facility

Below, or as an attachment to this form, provide a description of all crematory operations at the facility in sufficient detail to demonstrate the facility's eligibility for use of this air general permit and to provide a basis for tracking any future equipment or process changes at the facility. Describe all air pollutant-emitting processes and equipment at the facility, and identify any air pollution control measures or equipment used.
See attached process flow diagram.

* NATURAL GAS FIRED PER 9/15/10
TELECON W/ OAR PATRICK LORNE.
R.

PLOT PLAN

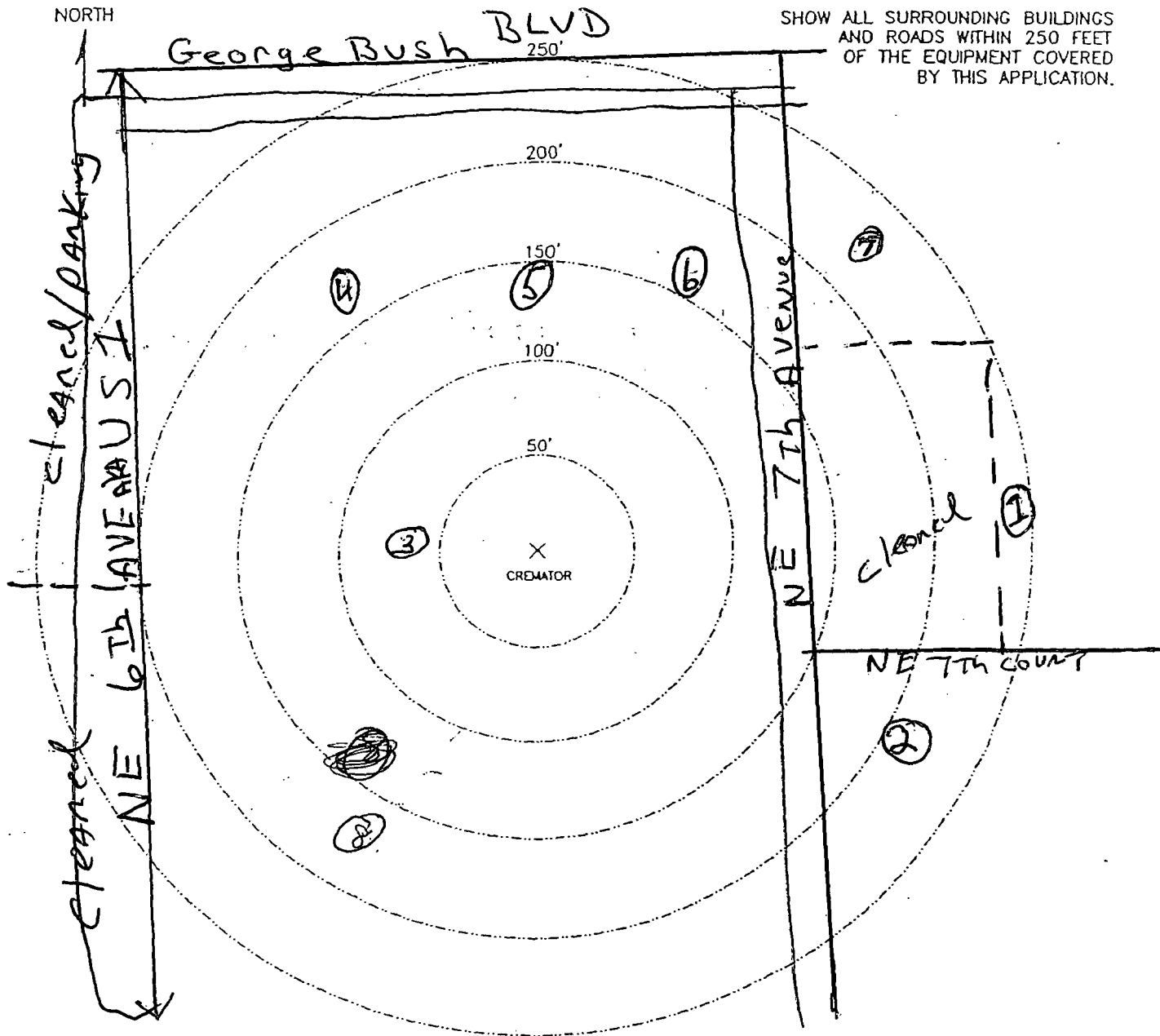

SHOW ALL SURROUNDING BUILDINGS AND ROADS WITHIN 250 FEET OF THE EQUIPMENT COVERED BY THIS APPLICATION.

INSTRUCTIONS

1. INDICATE LOCATION AND TYPE OF BUILDING BY THE USE OF SMALL NUMBERED CIRCLES WITH THE DESCRIPTION BELOW.
2. SHOW ROADS AS LINES REPRESENTING THE ROAD EDGES. INDICATE STREET NAMES AND HIGHWAY NUMBERS.
3. SHOW WOODED OR CLEARED AREA BY APPROXIMATE BOUNDARY LINES AND THE WORDS "WOODS," "CLEARED," "CORNFIELD," ETC.

STRUCTURE DESCRIPTION

- (1) METAL STRUCTURE
- (2) CONCRETE BLOCK
- (3) CONCRETE BLOCK
- (4) CONCRETE BLOCK
- (5) CONCRETE BLOCK
- (6) CONCRETE BLOCK
- (7) CONCRETE BLOCK
- (8) CONCRETE BLOCK
- (9)
- (10)

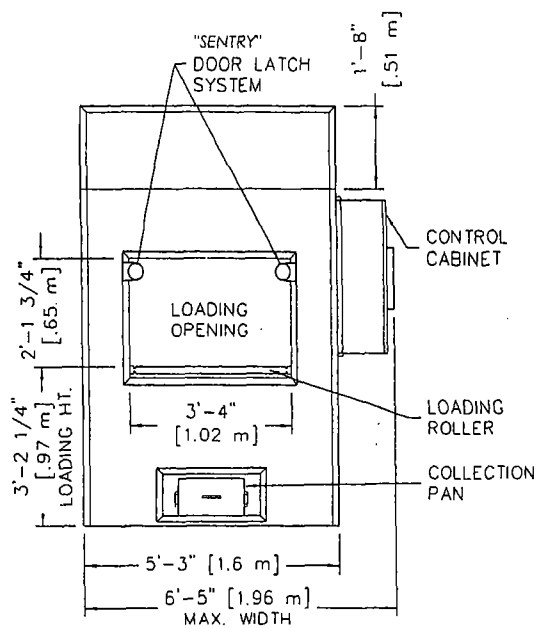

FRONT
ELEVATION

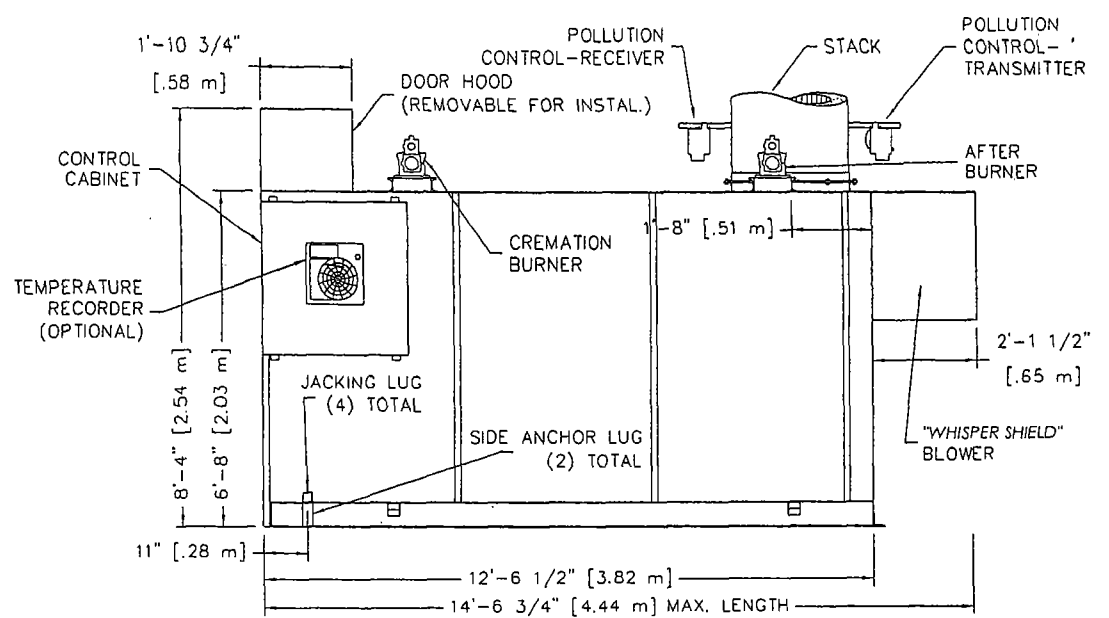

RIGHT SIDE
ELEVATION

NOTES:

- 1) CONTROL CABINET CAN BE MOUNTED ON THE LEFT OR RIGHT SIDE, OR REMOTELY.
- 2) CHAMBER WIDTH IS 39" [0.99m].

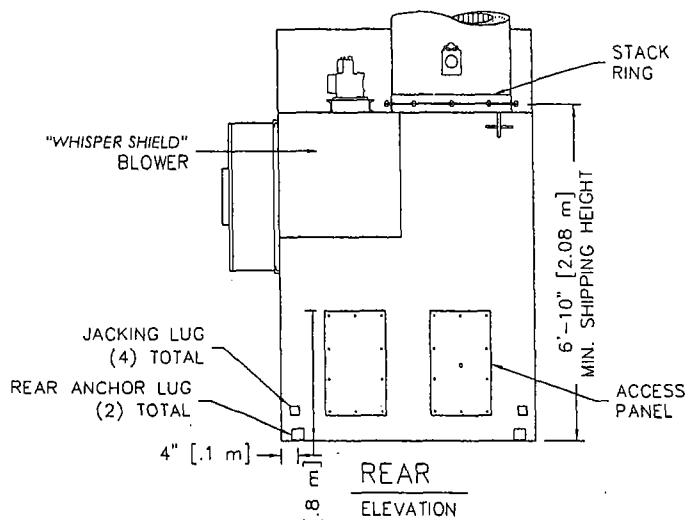

REAR
ELEVATION

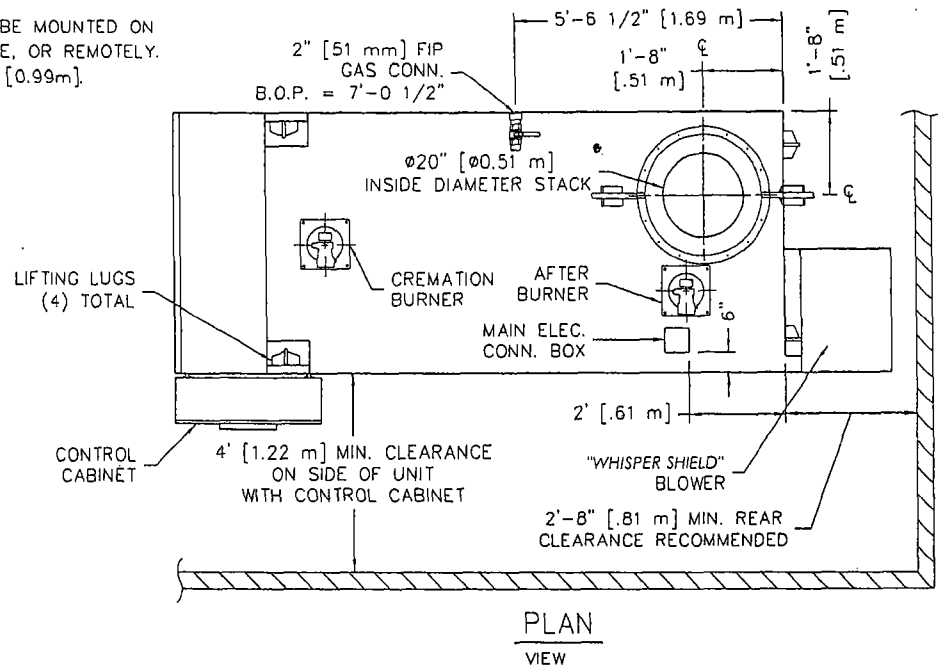

PLAN
VIEW



2045 Sprint Boulevard
Apopka, Florida 32703
USA

POWER-PAK II

PLAN & ELEVATIONS INCL: CLEARANCES,
REQUIREMENTS & RECOMMENDATIONS

| | | | |
|-----------|----------------------------|-------------|---------|
| DATE: | 10-26-06 | SCALE: | 1/4"=1' |
| DRAWN: | JG | PLOT SCALE: | 1:48 |
| APRVD: | | SHEET: | 1 OF: 2 |
| DWG FILE: | PPII-MarketingPlanElevS1R4 | | |
| DWG #: | 0000140 | | |

LEGEND OF SYMBOLS

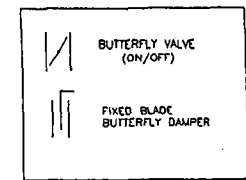

FLOW DIAGRAM

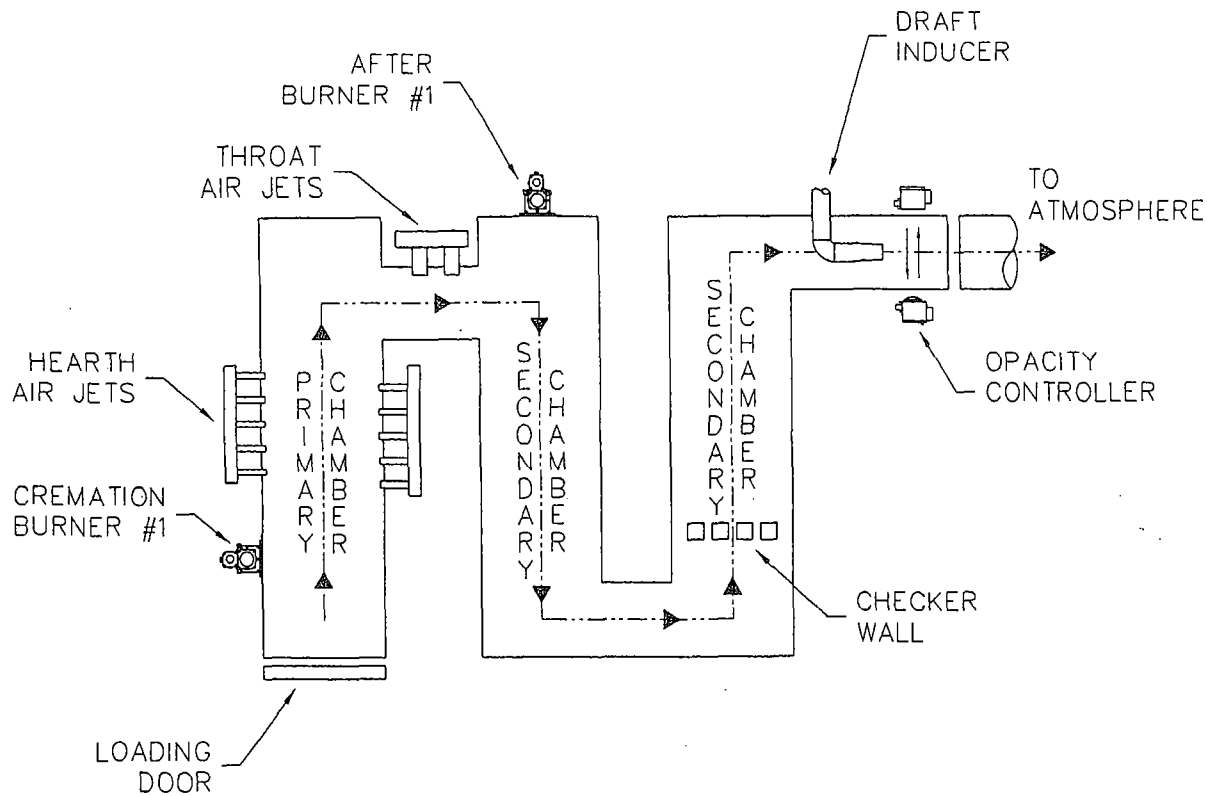

AIR SCHEMATIC

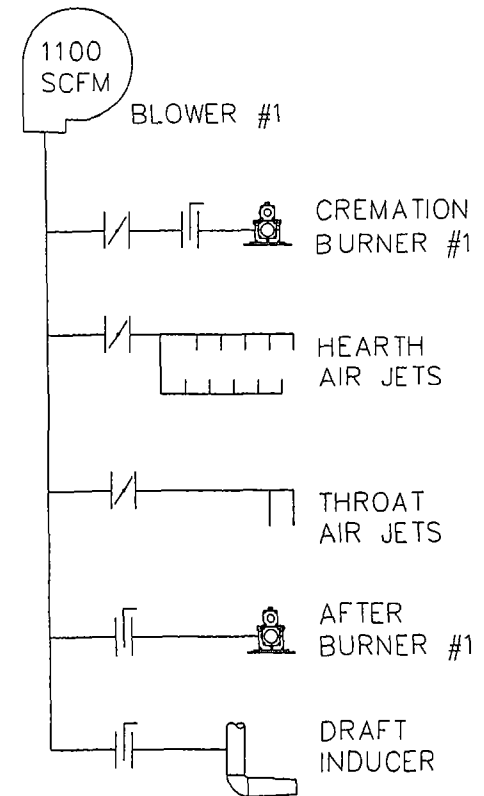

Matthews
CREMATION DIVISION
2045 Sprint Boulevard
Apopka, Florida 32703
USA

POWER PAK II
FLOW DIAGRAM
& AIR SCHEMATIC

| | | | |
|-----------|---------------------|-------------|---------|
| DATE: | 08-05-05 | SCALE: | 1/4"=1' |
| DRAWN: | JG | PLOT SCALE: | 1:48 |
| APRVD: | | SHEET: | 1 OF 1 |
| DWG FILE: | PPIIFlowDiaAirSchem | | |
| DWG #: | 0000523 | | |

PROCESS FLOW DIAGRAM CREMATOR

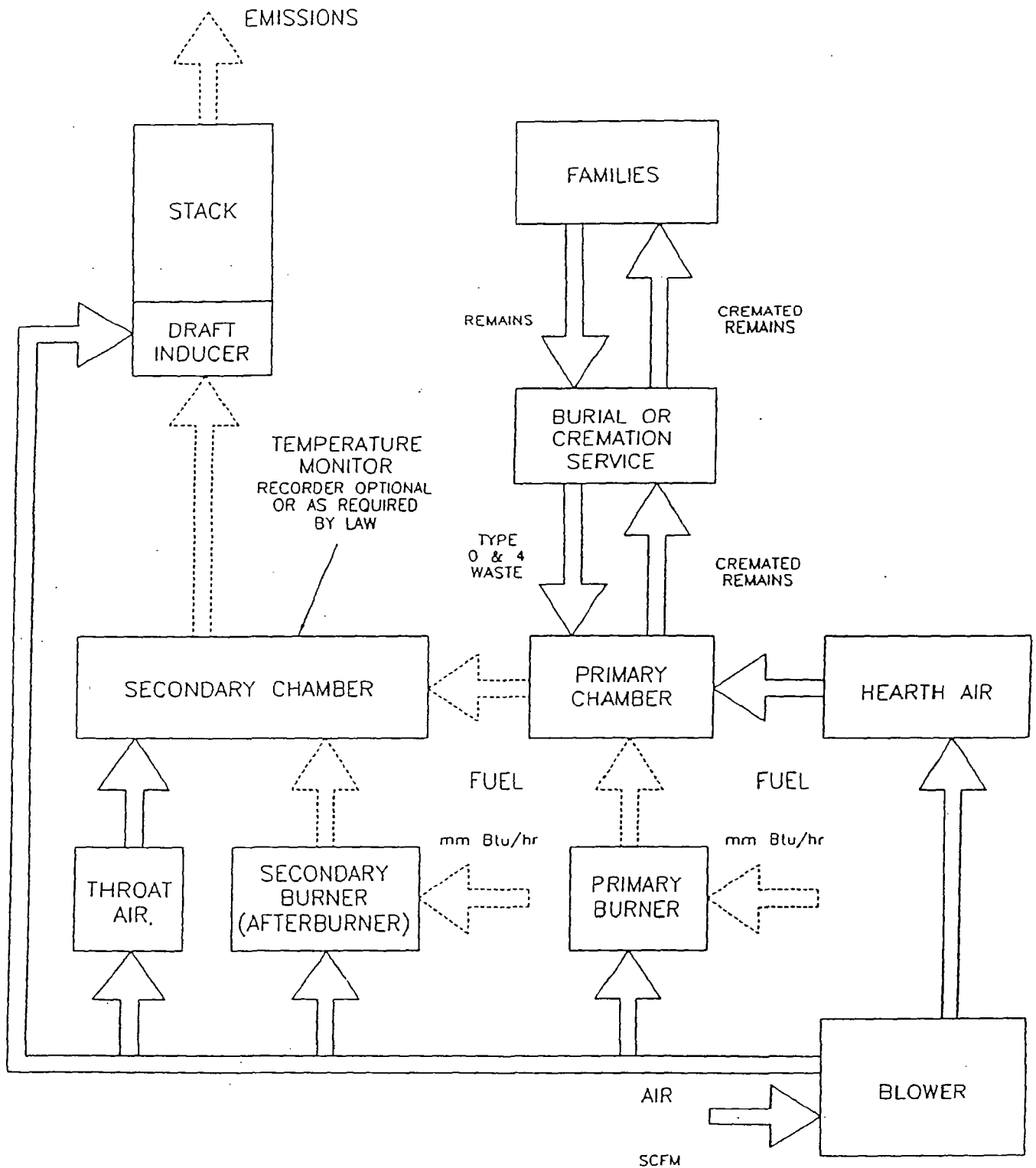

LEGEND OF SYMBOLS

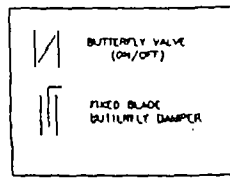

FLOW DIAGRAM

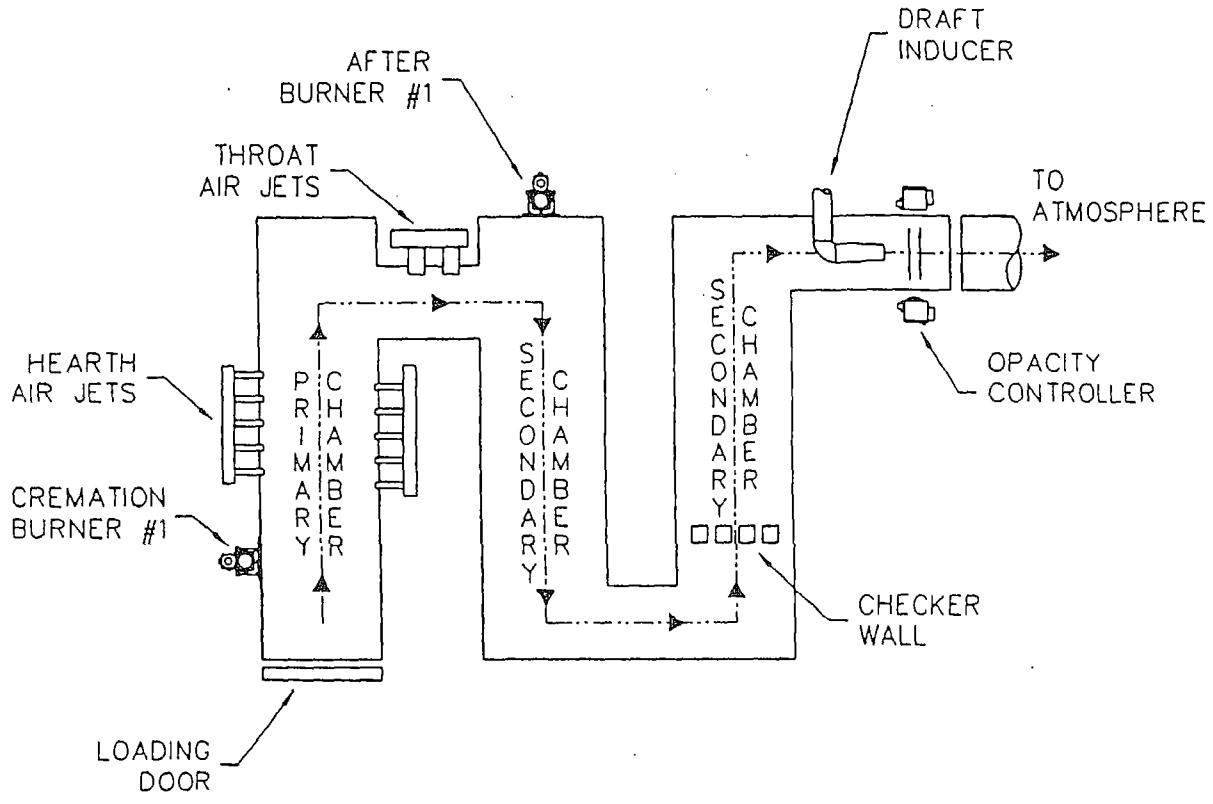

AIR SCHEMATIC

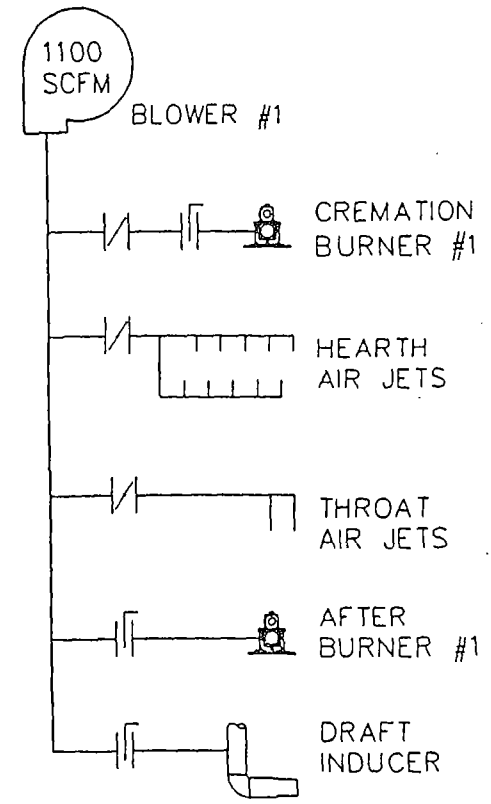

Matthews
CREMATION DIVISION
2045 Sprint Boulevard
Apopka, Florida 32703
USA

POWER PAK II
FLOW DIAGRAM
& AIR SCHEMATIC

| | | | |
|-----------|---------------------|-------------|---------|
| DATE: | 08-05-05 | SCALE: | 1/4"=1' |
| DRAWN: | JG | PLOT SCALE: | 1:48 |
| APRVD: | | SHEET: | 1 OF 1 |
| DWG FILE: | PPIIFlowDiaAirSchem | | |
| DWG #: | 0000523 | | |

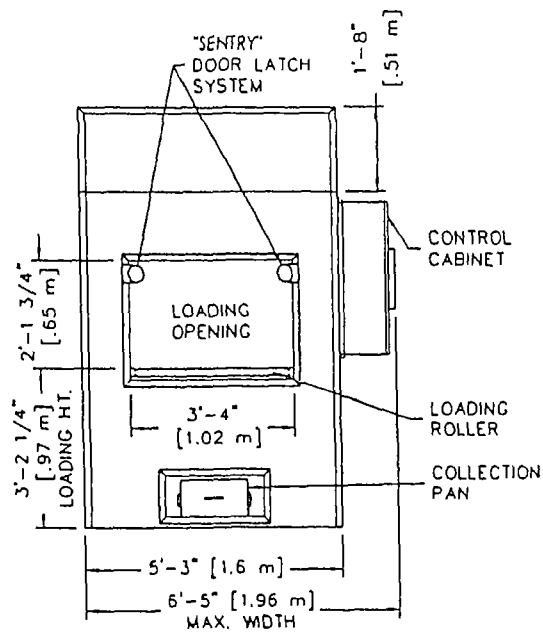

FRONT
ELEVATION

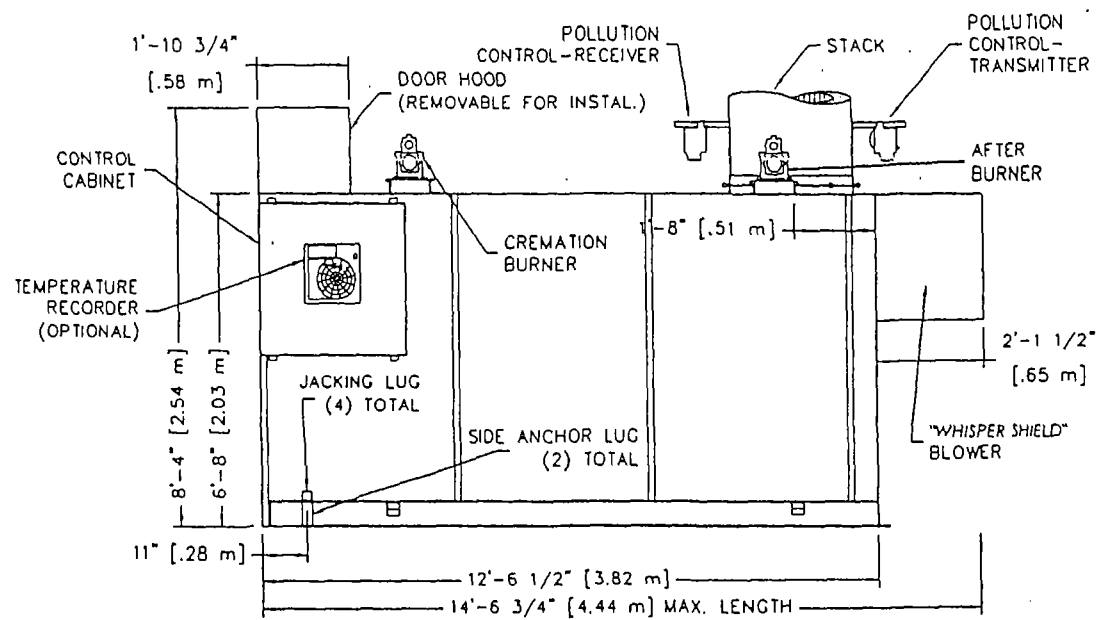

RIGHT SIDE
ELEVATION

NOTES:

- 1) CONTROL CABINET MOUNTS ON UNIT'S LEFT OR RIGHT SIDES, OR REMOTELY.
- 2) CHAMBER MOUTH IS 39" [0.99m].

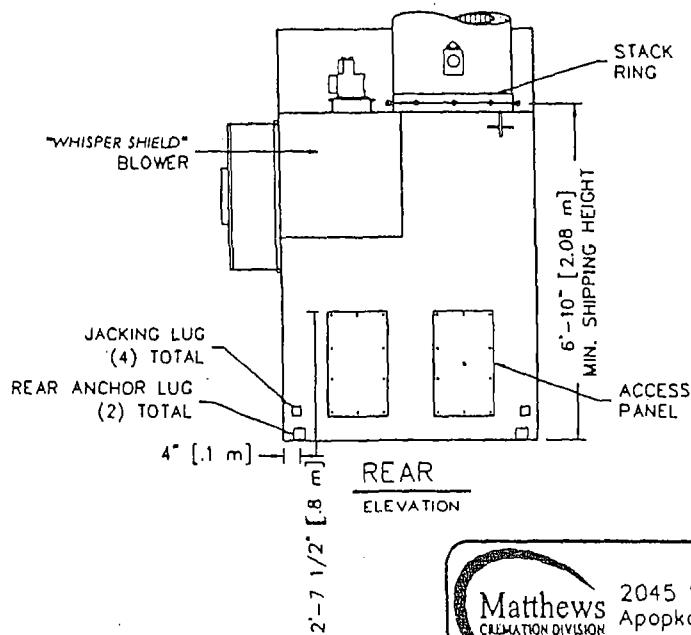

REAR
ELEVATION

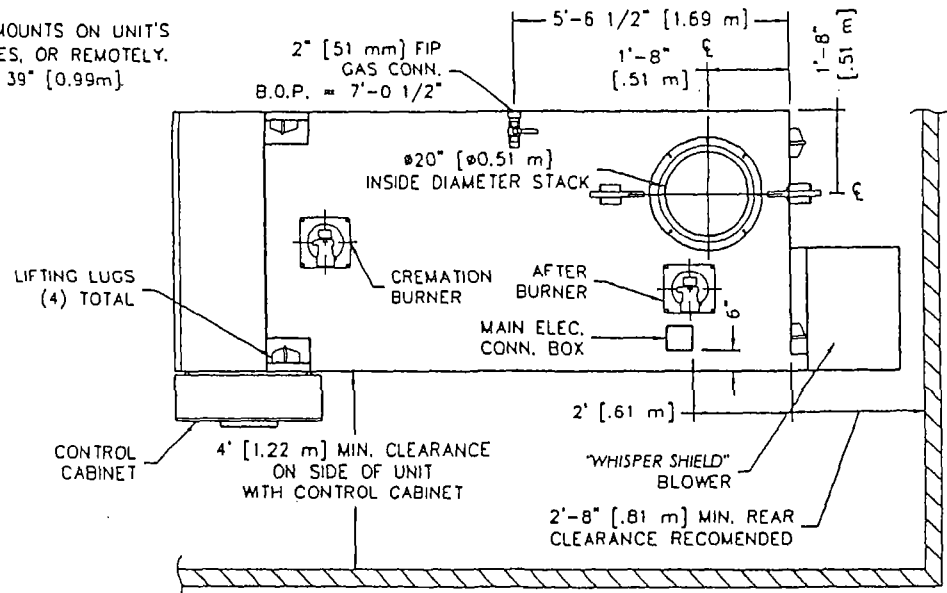

PLAN
VIEW

Matthews
CREMATION DIVISION

2045 Sprint Boulevard
Apopka, Florida 32703
USA

POWER-PAK II

PLAN & ELEVATIONS INCL: CLEARANCES,
REQUIREMENTS & RECOMENDATIONS

| | | | |
|-----------|----------------------------|-------------|---------|
| DATE: | 10-26-06 | SCALE: | 1/4"=1' |
| DRAWN: | JG | PLOT SCALE: | 1:48 |
| APRVD: | | SHEET: | 1 OF: 2 |
| DWG FILE: | PPII-MarketingPlanElevS1R4 | | |
| DWG #: | 0000140 | | |

RECOMMENDED

MINIMUM

| | | |
|---------------|-------------------|--------------------|
| TOP: (2) | 2 FEET [610 mm] | 6 INCHES [152 mm] |
| CABINET SIDE: | 4 FEET [1.22 m] | 4 FEET [1.22 m] |
| OTHER SIDE: | 2 FEET [610 mm] | 6 INCHES [152 mm] |
| FRONT: | 9 FEET [2.74 m] | 8 FEET [2.44 m] |
| REAR: | 3 FEET [0.91 m] | 32 INCHES [812 mm] |
| STACK: | 6 INCHES [152 mm] | 6 INCHES [152 mm] |

- FOR CLEARANCES OTHER THAN THOSE SHOWN, OR FOR SPECIAL REQUIREMENTS, CONSULT YOUR MCD REP.
- FROM HIGHEST POINT ON UNIT.
- CONTROL CABINET MOUNTS ON UNIT'S LEFT OR RIGHT SIDES, OR REMOTELY. (SEE PLAN VIEW, SHEET 1).
- REAR OF UNIT REFERS TO THE "BACK PLATE", RATHER THAN THE BACK OF THE "WHISPER SHIELD". (SEE PLAN VIEW, SHEET 1).

FUEL: A PRESSURE REGULATOR ADJUSTABLE TO 7" [178 mm] W.C. FOR NATURAL GAS, OR 11" [279 mm] W.C. FOR LP GAS.

CAPACITY: RANGES FROM 2.0 TO 3.0 MILLION BTU/HR [2.1 TO 3.1 MILLION KILOJouLES/HR] DEPENDING UPON AMOUNT OF BURNERS.

ELECTRICAL: 230 VOLT, 3Ø, (40A BREAKER) AND 115v (10A BREAKER), OR 230 VOLT, 1Ø, (70A BREAKER) AND 115v (10A BREAKER) 50/60 HERTZ

AIR: LOUVER NEAR THE REAR OF THE UNIT CAPABLE OF PASSING 2,500 CU FT/MIN [70.8 CU M/MIN] OF FREE AIR (36" X 36") [914 mm X 914 mm].

- APPLY A 1/2" THICK MORTAR JOINT TO EXPOSED REFRACTORY SURFACE IN STACK RING. LOWER THE BASE STACK SECTION (B) ONTO STACK RING (A) AND FASTEN WITH HARDWARE PROVIDED (NO MORE THAN (2) STACK SECTIONS SHALL BE LIFTED TOGETHER). REPEAT PROCESS FOR REMAINING STACK SECTIONS. IF SECTIONS OF VARYING LENGTHS ARE SUPPLIED, ASSEMBLE AS TO AVOID FLANGES & LIFTING EYES INTERFERING WITH RAIN COLLAR LOCATION.
- INSTALL STORM COLLAR ON STACK, 3" [76 mm] ABOVE NON-COMBUSTIBLE LINER (FLASHING), ALLOWING FOR PROPER VENTILATION (SEE DETAIL).
- APPLY A 1/4" [6 mm] BEAD OF HIGH-TEMPERATURE SILICON SEALANT (PROVIDED BY MCD) TO THE JOINT BETWEEN THE STORM COLLAR (C) AND THE STACK (B).
- STORM COLLAR IS FURNISHED BY MCD. THE NON-COMBUSTIBLE LINER (FLASHING) TO BE PROVIDED BY THE OTHERS.
- IF FIFTY PERCENT OF THE STACK LENGTH IS ABOVE THE ROOF, GUY WIRES MAY BE REQUIRED. CONSULT WITH YOUR MCD REP.
- RAIN CAP NOT REQUIRED.

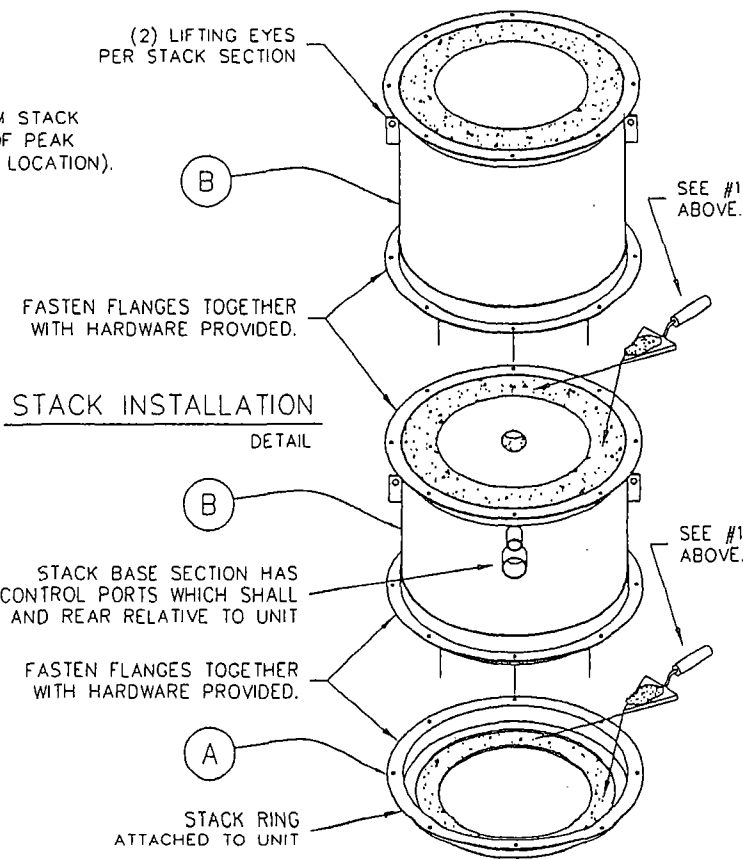
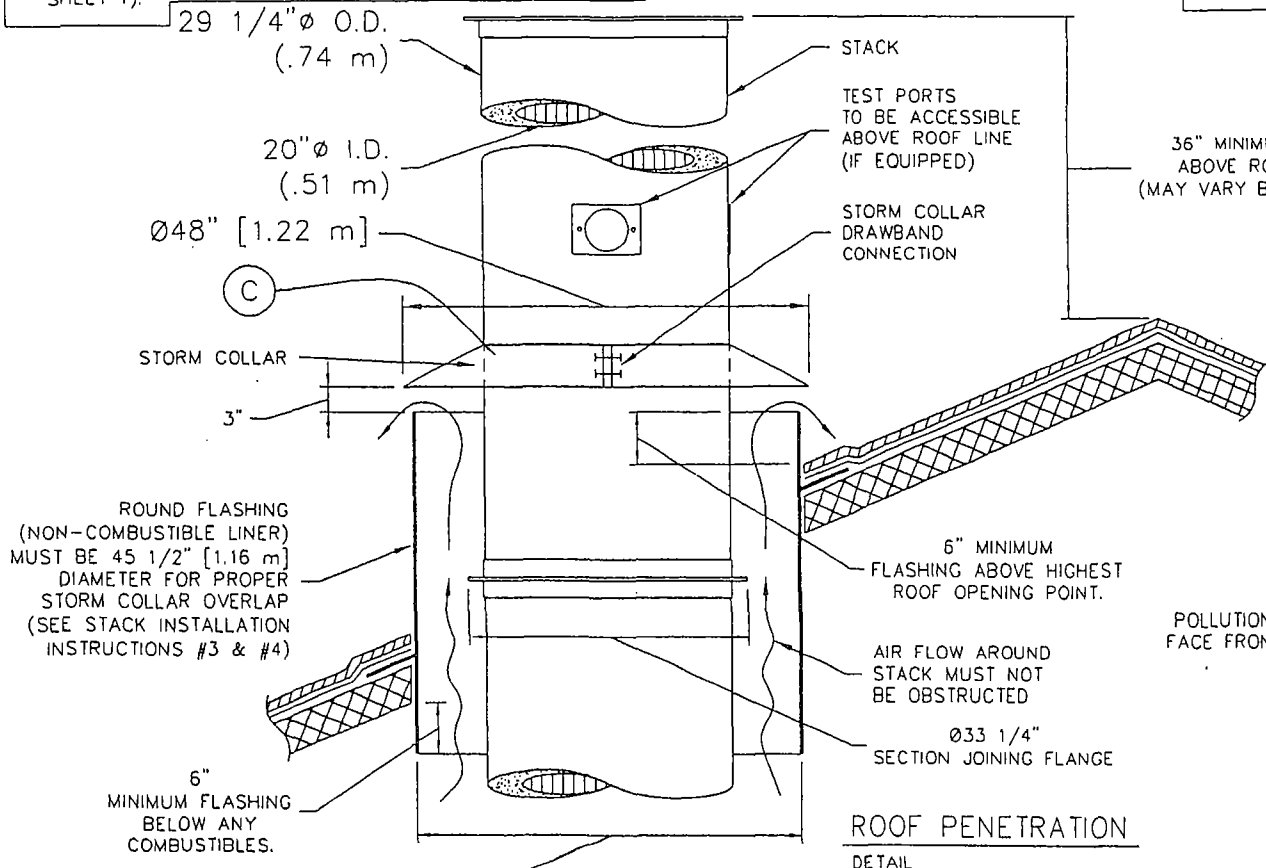

29 1/4" Ø O.D. (.74 m)

20" Ø I.D. (.51 m)

Ø48" [1.22 m]

STORM COLLAR

3"

ROUND FLASHING (NON-COMBUSTIBLE LINER) MUST BE 45 1/2" [1.16 m] DIAMETER FOR PROPER STORM COLLAR OVERLAP (SEE STACK INSTALLATION INSTRUCTIONS #3 & #4)

6" MINIMUM FLASHING BELOW ANY COMBUSTIBLES.

Ø45" REQUIRED FOR PROPER STACK CLEARANCE.

36" MINIMUM STACK ABOVE ROOF PEAK (MAY VARY BY LOCATION).

ROOF PENETRATION
DETAIL

STACK INSTALLATION
DETAIL

2045 Sprint Boulevard
Apopka, Florida 32703
USA

POWER-PAK II

STACK DETAILS, CLEARANCES & INSTALLATION INSTRUCTIONS.
REFRACTORY STACK DETAIL

| | | | |
|-----------|---------------------------|-------------|---------|
| DATE: | 08-18-05 | SCALE: | 1/2" = |
| DRAWN: | JG | PLOT SCALE: | 1:2 |
| APRVD: | | SHEET: | 2 OF: 2 |
| DWG FILE: | PPII-MarketingStackRefS2R | | |
| DWG #: | 000014 | | |

SPECIFICATIONS- Model Power-Pak II

1. Equipment Type Model Power-Pak II
 - A. Model No. IE43-PPII
 - B. Underwriters Laboratories Listing and File No. .. 87E8; MH14647

2. Dimensions
 - A. Footprint 12' - 6 1/2" x 6' - 8"
 - B. Maximum Length 14' - 6 1/2" (4.43 m)
 - C. Maximum Width 6' - 5" (1.96 m)
 - D. Maximum Height 8' - 4" (2.54 m)
 - E. Chamber Loading Opening 25 3/4" H x 39" W (655 mm x 990 mm)

3. Weight 24,000 lbs. (11,000 kg)

4. Utility/Air Requirements
 - A. Gross Gas Input, Natural or LP Gas 2,000,000 BTU/hr. (2,100,000 kJ/h)
2,500,000 BTU/hr. (2,600,000 kJ/h) if equipped
with preheat burner
 - Running Gas Pressure, Natural Gas 7 inches (180 mm) water column or greater
 - Running Gas Pressure, LP Gas 11 inches (280 mm) water column or greater
 - B. Electrical Supply 230 volt, 3Ø or 1Ø, 50/60 hz (other available)
 - C. Air Supply 2,500 cfm (70 standard m³/min)

5. Incineration Capacity 150 lbs./hr. (68 kg/h)

6. Typical Loading Capacity of Waste Types 750 lbs. (340 kg/h)

7. Construction and Safety Standards Incineration Institute of America, Underwriters
Laboratories, Canadian Standards Association

8. Steel Structure Construction
 - A. Frame 2" (51 mm) square tubing
 - B. Front/Rear Plates 3/8" (10 mm) plate
 - C. Floor Plates 3/16" (5 mm) plate
 - D. Outer Side Casing 12 gauge (3 mm) plate
 - E. Inner Side Casing 12 gauge (3 mm) plate

9. Stack Construction
 - A. Inner Wall 4 1/2" (110 mm) insulating firebrick or castable
 - B. Outer Wall 12 gauge (3 mm) sheet, 304 s.s., welded seams
(unlined stack available)

10. Draft Nozzle Construction Schedule 40 type 316 s.s. pipe, welded
connections

11. Main Chamber Door Construction
 - A. Steel Shell 3/16" (5 mm) steel, welded with reinforcement
 - B. Outer Refractory 1" (25 mm) insulating block
 - C. Inner Refractory 4 1/2" (110 mm) insulating firebrick

12. Primary Chamber Wall Construction
 - A. Outer Casing Wall 12 gauge (3 mm) sheet
 - B. Inner Frame/Air Compartment 2" (51 mm) air compartment
 - C. Inner Casing Wall 12 gauge (3 mm) sheet

SPECIFICATIONS- Model Power-Pak II

- D. Outer Refractory Wall 5" (127 mm) insulating block
- E. Inner Refractory Wall 4½" (110 mm) firebrick

- 13. Secondary Chamber Wall Construction
 - A. Outer Casing Wall 12 gauge (3 mm) sheet
 - B. Inner Frame/Air Compartment 2" (51 mm) air compartment
 - C. Inner Casing Wall 12 gauge (3 mm) sheet
 - D. Outer Refractory Wall 6" (150 mm) insulating block
 - E. Inner Refractory Wall 4½" (110 mm) firebrick

- 14. Refractory Temperature Ratings
 - A. Standard Firebrick 3,100° F. (1700° C)
 - B. Insulating Firebrick..... 2,600° F. (1430° C)
 - C. Castable Refractory (Hearth) 2,550° F. (1370° C)
 - D. Castable Refractory 2,550° F. (1370° C)
 - E. Insulating Block..... 1,900° F. (1040° C)
 - F. Bonding Mortar 3,200° F. (1760° C)

- 15. Chamber Volumes (not including external flues, stacks or chimneys)
 - A. Primary Chamber 64 cubic feet (2.0 m³)
 - B. Secondary Chamber 74 cubic feet (2.0 m³)

- 16. Emission Control Features
 - A. Secondary Chamber with Afterburner Included
 - B. Opacity Monitor and Controller with Visual and Audible Alarms..... Included
 - C. Auxiliary Air Control System..... Included
 - D. Microprocessor Temperature Control System..... Included

- 17. Operating Temperatures
 - A. Primary Chamber..... 1,200° F. - 1,800° F. (650° C - 1000° C)
 - B. Secondary Chamber 1,400° F. - 1,800° F. (760° C - 1000° C) as required

- 18. Secondary Chamber Retention Time..... > 1 second

- 19. Ash Removal Door functions as a heat shield. Sweep out beneath front door into hopper that fills collection pan.

- 20. Safety Interlocks
 - A. High Gas Pressure Optional
 - B. Low Gas Pressure Optional
 - C. Blower Air Pressure Included
 - D. Door Position Included
 - E. Opacity Included
 - F. Motor Starter Function Included
 - G. Chamber Temperature Included
 - H. Motor Overload Included
 - I. Flame Quality..... Included
 - J. Burner Safe Start Included

- 22. Burner Description..... The nozzle mix burners used on this cremation equipment are industrial quality and designed

SPECIFICATIONS- Model Power-Pak II

for incinerator use.

- 23. Ultraviolet Flame Detection..... Ultraviolet flame detection has proven to be the most reliable means of flame safety. The system is completely sealed in a quartz capsule to eliminate problems, caused by moisture and dust created in the cremation process, which affect flame rod detectors.
- 24. Operating Panel Indicating Lights
 - A. Safe Run..... Included
 - B. Door Closed..... Included
 - C. Pollution Alarm..... Included
 - D. Afterburner On (Secondary Burner)..... Included
 - E. Cremation Burner On..... Included
 - F. Low Fire Cremation Burner On..... Included
 - G. Afterburner (Secondary Burner) Reset..... Included
 - H. Cremation Burner Reset..... Included
 - I. Hearth Air..... Included
 - J. Throat Air Off..... Included
- 25. Automatic Timer Functions
 - A. Master Cycle..... Included
 - B. Afterburner (Secondary Burner)..... Included
 - C. Cremation Burner..... Included
 - D. Low Fire Cremation Burner..... Included
 - E. Hearth Air..... Included
 - F. Throat Air..... Included
 - G. Pollution Monitoring..... Included
 - H. Afterburner (Secondary Burner) Prepurge..... Included
 - I. Cremation Burner Prepurge..... Included
 - J. Cool Down..... Included
- 26. Exterior Finish
 - A. Primer..... 2 coats rust inhibiting
 - B. Finish..... 2 coats textured finish
- 27. Start-Up and Training Startup of cremation equipment and training of operators to properly operate and maintain the equipment is performed on-site under actual operating conditions. Included is a comprehensive owner's manual, with details on the equipment, its components and proper operation.
- 28. Environmental Submittals Complete technical portion of state environmental permits. Engineering calculations, technical data, existing stack test results and equipment blueprints provided.

CREMATOR MASS BALANCE

Matthews Cremation Division
(formerly Industrial Equipment & Engineering Co.)
Model IE43-PPII (Power-Pak II) Ultra
Crematory Incinerator, Fired on Natural Gas

18-Oct-08

THESE CALCULATIONS HAVE BEEN PREPARED TO EVALUATE THE COMBUSTION PROCESS IN THE POWER-PAK II CREMATORY INCINERATOR

Firing Rate 150 lb/hr = 100 % of 150 lbs/hr Rated Capacity)
Excess Air 65 %

THE INCINERATOR INSTITUTE OF AMERICA HAS PUBLISHED THE FOLLOWING SPECIFICATIONS COVERING AVERAGE WASTES.

| WASTE TYPE | TYPE 0 | TYPE 4 |
|------------------------------------|--------|--------|
| BTU PER POUND | 8500 | 1000 |
| POUND ASH PER POUND WASTE | 0.05 | 0.05 |
| POUND MOISTURE PER POUND WASTE | 0.1 | 0.85 |
| POUND COMBUSTIBLES PER POUND WASTE | 0.85 | 0.1 |
| HOURLY CONSUMPTION OF WASTE (LBS) | 5.0 | 145.0 |

| SPECIFICATIONS | | |
|--|------|-------------------------|
| PRIMARY BURNER FUEL CONSUMPTION (MMBTU/HR) | 0.45 | 0.7 MMBTU /HR UL RATING |
| PRIMARY CHAMBER VOLUME (CU.FT) | 64 | |
| HEARTH AREA (SQ.FT) | 26.4 | |
| SECONDARY BURNER FUEL CONSUMPTION (MMBTU/HR) | 1.2 | |
| ADDITIONAL COMBUSTION AIR SUPPLIED | | |
| THROAT AIR (SCFM) | 200 | 3 " w.c. @ test tap |
| HEARTH AIR (SCFM) | 100 | 4 " w.c. @ test tap |
| SEC. CHAMBER OPERATING TEMPERATURE (°F) | 1800 | |
| SECONDARY CHAMBER VOLUME (CU. FT) | 74 | |
| SEC. CHAMB. CROSS-SECTIONAL AREA (SQ. FT) | 2.7 | |
| FLAME PORT AREA (SQ. FT) | 2.8 | |
| MIXING BAFFLES AREA (SQ. FT) | 1.4 | |

1. TOTAL FLUE PRODUCTS

A. PRIMARY BURNER NATURAL GAS USAGE

$$\frac{450000 \text{ BTU/HR}}{1000 \text{ BTU/CF}} = 450 \text{ CFH} = 8 \text{ CFM}$$

B. COMBUSTION AIR FOR PRIMARY BURNER

$$\frac{450 \text{ CF}}{\text{HR}} \times \frac{2 \text{ CF O}_2}{\text{CF}} \times \frac{1 \text{ CF AIR}}{0.21 \text{ CF O}_2} = 4327 \text{ CFH} = 72 \text{ CFM (Stoichiometric)}$$

$$1658.5 \times 5.3 \text{ SI} \times 0.97 \sqrt{0.5} = 6029 \text{ CFH} = 100 \text{ CFM (Actual)}$$

C. SECONDARY BURNER NATURAL GAS USAGE

$$\frac{1200000 \text{ BTU/HR}}{1000 \text{ BTU/CF}} = 1200 \text{ CFH} = 20 \text{ CFM}$$

D. COMBUSTION AIR FOR SECONDARY BURNER

$$\frac{1200 \text{ CF}}{\text{HR}} \times \frac{2 \text{ CF O}_2}{\text{CF}} \times \frac{1 \text{ CF AIR}}{0.21 \text{ CF O}_2} = 11538 \text{ CFH} = 192 \text{ CFM (Stoichiometric)}$$

$$1658.5 \times 5.3 \text{ SI} \times 0.97 \sqrt{2.25} = 12790 \text{ CFH} = 213 \text{ CFM (Actual)}$$

E. PRODUCTS FROM TYPE 0 WASTE (CONTAINER)

$$0.95 \text{ LBS/LB BURNED} \times 5 \text{ LB/HR BURN RATE} = 5 \text{ LBS/HOUR}$$

$$= 63 \text{ CFH}$$

$$= 1 \text{ CFM}$$

F. PRODUCTS FROM TYPE 4 WASTE (TISSUE)

$$0.95 \text{ LBS/LB WASTE} \times 145 \text{ LB/HR BURN RATE} = 138 \text{ LBS/HOUR}$$

$$= 1833 \text{ CFH}$$

$$= 31 \text{ CFM}$$

G. ADDITIONAL COMBUSTION AIR (HEARTH & THROAT AIR)

$$12000 \text{ CFH} = 200 \text{ CFM}$$

$$6000 \text{ CFH} = 100 \text{ CFM}$$

$$= 150 \text{ CFM/CREMATION}$$

H. TOTAL FLUE PRODUCTS

$$= \underline{\underline{523 \text{ SCFM}}}$$

2. VELOCITY AND TIME CALCULATIONS

A. TOTAL PRODUCTS ACFM @ 1800 °F

$$\frac{2260 \text{ °RANKINE}}{530 \text{ °RANKINE}} \times 522.8 \text{ CFM} = 2229 \text{ ACFM}$$

B. RETENTION TIME

$$\frac{74 \text{ CU. FT}}{2229 \text{ ACFM}} \times \frac{60 \text{ SECONDS}}{1 \text{ MINUTE}} = 2.0 \text{ SECONDS}$$

C. VELOCITY IN FLAME PORT

$$\frac{2229 \text{ ACFM}}{2.8 \text{ SQ. FT}} \times \frac{1 \text{ MINUTE}}{60 \text{ SECONDS}} = 13.3 \text{ FEET/SECOND}$$

D. VELOCITY AT MIXING BAFFLES

$$\frac{2229 \text{ ACFM}}{1.4 \text{ SQ. FT}} \times \frac{1 \text{ MINUTE}}{60 \text{ SECONDS}} = 26.5 \text{ FEET/SECOND}$$

E. VELOCITY IN SECONDARY CHAMBER

$$\frac{2229 \text{ ACFM}}{2.7 \text{ SQ. FT}} \times \frac{1 \text{ MINUTE}}{60 \text{ SECONDS}} = 13.8 \text{ FEET/SECOND}$$

STACK CONDITIONS

| | |
|---|-------|
| STACK EXIT DIAMETER (INCHES) | 20 |
| STACK EXIT AREA (SQ. FT) | 2.18 |
| FLUE GAS TEMPERATURE (°F) (Secondary chamber exhaust) | 1800 |
| INDUCING AIR TEMPERATURE (°F) | 70 |
| INDUCING AIR QUANTITY (CFH) | 15000 |

5. STACK CALCULATIONS

A. STACK GAS TEMPERATURE

$$523 (T - 2260) = 250 (T - 530) = 1240 \text{ °FAHRENHEIT}$$

B. STACK GAS VOLUME (STACK CONDITIONS)

$$\left(\frac{523}{60} + \frac{250}{60} \right) \text{ SCFM} \times \frac{1700}{530} = 41 \text{ ACFS}$$

$$= 2479 \text{ ACFM}$$

$$= 773 \text{ SCFM}$$

C. STACK EXIT VELOCITY

| | | |
|----------------|---|----------------------|
| <u>41</u> ACFS | = | 19 FEET PER SECOND |
| 2.18 SQ. FT | = | 1137 FEET PER MINUTE |

D. PERCENT WATER VAPOR (Volume Conversion)

| | | | | |
|-------------------------|---|-----------------------|---|-----------------------------------|
| 0.1 lb/lb waste Type 0 | X | <u>29</u> Mol Wt. Air | = | 0.16 lb/lb waste Type 0 |
| | | 18 Mol. Wt. Water | | |
| 0.85 lb/lb waste Type 4 | X | <u>29</u> Mol Wt. Air | = | 1.36 lb/lb waste Type 4 |
| | | 18 Mol. Wt. Water | | |
| 0.16 lb/lb waste Type 0 | X | 5 LB/HR BURN RATE | = | 0.8 lb/hr |
| 1.36 lb/lb waste Type 4 | X | 145.0 LB/HR BURN RATE | = | 198 lb/hr |
| 2.25 lb/lb fuel (NG) | X | 69 LB/HR BURN RATE | = | 156 lb/hr |
| | | | = | 355 lb/hr total |
| | | | = | 116 SCFM |
| | | | = | 15 % Water Vapor (Theoretical) |

E. PERCENT O2 & CO2 @ CREMATOR TEST PORT (Theoretical)

| | | | | |
|---------------------|----------|----------------------|----------|-----------------------|
| 1650 CFH CH4 | | 5786 CFH O2 | | |
| | | 27819 CFH AIR | | |
| | | 1650 CFH CO2 | | |
| | | 3300 CFH H2O | | |
| 15 LB AIR | 8500 BTU | 0.85 LB | 5.0 LB | 54 LB/HR AIR - Type 0 |
| 10000 BTU | LB | LB | HR | 721 SCFH |
| 15 LB AIR | 1000 BTU | 0.1 LB | 145.0 LB | 22 LB/HR AIR - Type 4 |
| 10000 BTU | LB | LB | HR | 289 SCFH |
| | | Stoichiometric Air = | | 16876 SCFH |
| | | | | 281 SCFM |
| | | Excess Air = | | 10942 SCFH |
| | | | | 182 SCFM |
| Total Flue Products | | | | 523 CFM |
| | | | | - 116 CFM MOISTURE |
| | | | | <u>407 CFM GAS</u> |
| CO2 | 2802 CFH | = | 47 SCFM | = 11 % CO2 |
| O2 | 2276 CFH | = | 38 SCFM | = 9 % O2 |

F. PERCENT O2 & CO2 @ STACK TEST PORT (Theoretical)

| | | | | |
|--|----------|---|-----------|--------------------|
| Total Flue Products (adding inducing air to total flue products) | | | | 773 CFM |
| | | | | - 116 CFM MOISTURE |
| | | | | <u>657 CFM GAS</u> |
| CO2 | 2802 CFH | = | 47 SCFM | = 7 % CO2 |
| O2 | 5396 CFH | = | 89.9 SCFM | = 14 % O2 |

**EMISSIONS TESTING
REPORT**

PERMIT NO. 0950126-005-AG

**IE43-PPII, POWER-PAK II
CREMATOR**

PREPARED FOR:

BALDWIN FAIRCHILD

ORLANDO, FLORIDA

MAY 5, 2005

PREPARED BY:

ATC



AIR TESTING & CONSULTING, INC.

333 FALKENBURG ROAD, SUITE B-214

TAMPA, FLORIDA 33619

ATC



AIR TESTING & CONSULTING, INC.

333 FALKENBURG ROAD, SUITE B-214
TAMPA, FLORIDA 33619

To the best of my knowledge, all field and analytical procedures comply with Florida Department of Environmental Protection requirements and all test data and plant operating data are true and correct.

A handwritten signature in cursive script that reads "Kenneth E. Given".

Kenneth E. Given, P.E.

5-18-05

Date

1.0 INTRODUCTION

On May 5, 2005, Air Testing & Consulting, Inc., conducted the following tests on Baldwin Fairchild's Human Crematory Incinerator located at 301 N. Ivanhoe Blvd. in Orlando, Florida:

- (1) *Particulate Emission (EPA Methods 1 – 5)*
- (2) *Carbon Monoxide (EPA Method 10)*
- (3) *Visible Emissions (EPA Method 9)*
- (4) *Oxygen (EPA Method 3A)*

These tests were performed at the request of Mathews Cremation Division to prove compliance on the Power Pak II crematory incinerator. Orange County, Environmental Protection Division, representatives, Gregory Bryant, Ilka Bundy and John Casper audited the test.

2.0 SUMMARY OF RESULTS

The results of the emission testing are presented in the Test Summary. The Particulate emissions averaged 0.0549 grains per dry standard cubic foot (gr/dscf) and CO emissions averaged 2.2 parts per million (ppmv), each corrected to 7% O₂. Opacity, highest six-minute average, on the stack, was 0%.

3.0 SUMMARY OF TEST DATA

PLANT : BALDWIN

UNIT : POWER-PACK II

RUN NUMBERS : 1, 2, 3

| TEST DATE : 5/5/05 | #1 | #2 | #3 | AVERAGES |
|---|---------|---------|---------|----------|
| DATE | 5/5/05 | 5/5/05 | 5/5/05 | |
| START TIME | 10:32 | 13:05 | 15:27 | |
| END TIME | 11:50 | 14:09 | 16:29 | |
| STACK DIAMETER (INCHES) | 19.5 | 19.5 | 19.5 | |
| NOZZLE DIAMETER (INCHES) | 0.550 | 0.550 | 0.550 | |
| TEST TIME (MINUTES) | 60 | 60 | 60 | |
| NUMBER OF TEST POINTS PER RUN | 24 | 24 | 24 | |
| STACK GAS TEMPERATURE (°F) | 850.0 | 991.8 | 1128 | 989.9 |
| STACK GAS MOISTURE (%) | 12.51 | 9.76 | 6.56 | |
| STACK GAS MOLECULAR WEIGHT | 28.50 | 28.83 | 29.21 | |
| STACK GAS VOLUME SAMPLED (CUBIC FEET) | 34.375 | 36.840 | 40.110 | 37.108 |
| VOLUME SAMPLED (SCF @ 68°F) | 34.585 | 37.020 | 40.270 | 37.292 |
| STACK GAS VELOCITY (FEET PER SECOND) | 18.14 | 17.30 | 19.75 | 18.39 |
| STACK GAS FLOW RATE (ACFM) | 2257.0 | 2152.2 | 2457.7 | 2288.9 |
| STACK GAS FLOW RATE (DSCFM @ 68°F) | 801.7 | 711.5 | 769.2 | 760.8 |
| OXYGEN, % | 16.0 | 14.0 | 14.5 | |
| PARTICULATE CONC (GR/DSCF) @7% O ₂ | 0.0359 | 0.1122 | 0.0165 | 0.0549 |
| PARTICULATE MASS RATE (LBS/HOUR) | 0.0871 | 0.3396 | 0.0500 | 0.1589 |
| CO CONC @ 7% O ₂ , ppmv | 1.42 | 2.01 | 3.26 | 2.23 |
| CO MASS RATE (LBS/HOUR) | 0.00175 | 0.00310 | 0.00503 | 0.0033 |
| ISOKINETIC SAMPLING RATE, %I | 90.4 | 109.0 | 109.7 | |

FIELD DATA AND SAMPLES UNDER THE CONTROL OF:

TIM CAPELLE

LABORATORY ANALYSIS UNDER THE CONTROL OF:

ATC

Lorne and Sons Funeral Home
745 N.E. 6th Ave.
Delray Beach, FL 33483-5701

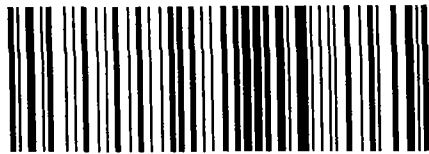

7007 0710 0004 5322 8633



0000017591
U.S. OFFICIAL MAIL
U.S. POSTAGE
0666
PENALTY FOR
PRIVATE USE \$300
POSTALIA 460257

FDED Receipts

PO Box 3070

Tallahassee, FL ~~32301~~-7555
32301

