

RECEIVED

APR 20 2010

HUMAN CREMATORY
AIR GENERAL PERMIT REGISTRATION FORM

DEPARTMENT OF AIR QUALITY
& MOBILE SOURCES

Part II. Notification to Permitting Office

(Detach and submit to appropriate permitting office; keep copy onsite)

Instructions: To give notice to the Department of an eligible facility's intent to use this air general permit, the owner or operator of the facility must detach and complete this part of the Air General Permit Registration Form and submit it to the appropriate Department of Environmental Protection or local air pollution control program office which has permitting authority. Please type or print clearly all information, and enclose the appropriate air general permit registration processing fee pursuant to Rule 62-4.050, F.A.C. (\$100 as of the effective date of this form)

0810039-005

Registration Type

Check one:

INITIAL REGISTRATION - Notification of intent to:

Construct and operate a proposed new facility.

Operate an existing facility not currently using an air general permit (e.g., a facility proposing to go from an air operation permit to an air general permit).

RE-REGISTRATION (for facilities currently using an air general permit) - Notification of intent to:

Continue operating the facility after expiration of the current term of air general permit use.

Continue operating the facility after a change of ownership.

Make an equipment change requiring re-registration pursuant to Rule 62-210.310(2)(e), F.A.C., or any other change not considered an administrative correction under Rule 62-210.310(2)(d), F.A.C.

Surrender of Existing Air Operation Permit(s) - For Initial Registrations Only

If the facility currently holds one or more air operation permits, such permit(s) must be surrendered by the owner or operator upon the effective date of this air general permit. In such case, check the first box, and indicate the operation permits being surrendered. If no air operation permits are held by the facility, check the second box.

All existing air operation permits for this facility are hereby surrendered upon the effective date of this air general permit; specifically permit number(s): _____

No air operation permits currently exist for this facility.

General Facility Information

Facility Owner/Company Name (Name of corporation, agency, or individual owner who or which owns, leases, operates, controls, or supervises the facility.)
Toale Brothers Funeral Home

Site Name (Name, if any, of the facility site; e.g., Plant A, Metropolis Plant, etc. If more than one facility is owned, a registration form must be completed for each.)
Bradenton Facility

Facility Location (Provide the physical location of the facility, not necessarily the mailing address.)
Street Address: 912 53rd Avenue West
City: Bradenton County: Manatee Zip Code: 34207

Facility Start-Up Date (Estimated start-up date of proposed new facility.) (N/A for existing facility)
N/A

Owner/Authorized Representative

Name and Position Title (Person who, by signing this form below, certifies that the facility is eligible to use this air general permit.)

Print Name and Title: Jeffery Toale, Owner

Owner/Authorized Representative Mailing Address

Organization/Firm: Toale Brothers Funeral Home
Street Address: P.O. Drawer T
City: Sarasota County: Sarasota Zip Code: 34230

Owner/Authorized Representative Telephone Numbers

Telephone: 941-955-4171 Fax: 941-751-3760
Cell phone (optional): jefftoale@toalebrothers.com

Facility Contact (If different from Owner/Authorized Representative)

Name and Position Title (Plant manager or person to be contacted regarding day-to-day operations at the facility.)

Print Name and Title: Jeffery Toale, Owner

Facility Contact Mailing Address

Organization/Firm: Toale Brothers Funeral Home
Street Address: P.O. Drawer T
City: Sarasota County: Sarasota Zip Code: 34230

Facility Contact Telephone Numbers

Telephone: Fax:
Cell phone (optional):

Owner/Authorized Representative Statement

This statement must be signed and dated by the person named above as owner or authorized representative

I, the undersigned, am the owner or authorized representative of the owner or operator of the facility addressed in this Air General Permit Registration Form. I hereby certify, based on information and belief formed after reasonable inquiry, that the facility addressed in this registration form is eligible for use of this air general permit and that the statements made in this registration form are true, accurate and complete. Further, I agree to operate and maintain the facility described in this registration form so as to comply with all applicable standards for control of air pollutant emissions found in the statutes of the State of Florida and rules of the Department of Environmental Protection and revisions thereof.

I will promptly notify the Department of any changes to the information contained in this registration form.

Signature Jeff G. Toale

Date April 16, 2010

Design Calculations

If this is an initial registration for a proposed new human crematory unit, provide design calculations to confirm a sufficient volume in the secondary chamber combustion zone to provide for at least a 1.0 second gas residence time at 1800 degrees F.

- Manufacturer's' design calculations attached.
- Registration is not for proposed new human crematory unit(s).

Description of Facility

Below, or as an attachment to this form, provide a description of all crematory operations at the facility in sufficient detail to demonstrate the facility's eligibility for use of this air general permit and to provide a basis for tracking any future equipment or process changes at the facility. Describe all air pollutant-emitting processes and equipment at the facility, and identify any air pollution control measures or equipment used.

Operation of a B&L Cremation Systems, Inc. Human Crematory model: Phoenix II Series. This system is natural gas fired with internal afterburner operating at a minimum of 1600^of at a residence time of 1 second @ 1800^of.

This system will replace the current industrial equipment Power Pak Crematory, which will be removed from the site.

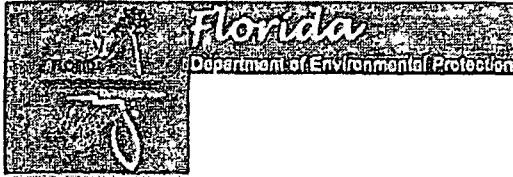

[Search](#)

[DEP Home](#) / [About DEP](#) / [Programs](#) / [Contact](#) / [Site Map](#)

Programs

- * Air Home
- * Compliance
- * Permitting
- * Monitoring
- * Small Business Assistance
- * Vehicles and Fuels

Information

- * About Us
- * Contacts
- * Data
- * eProducts
- * Events
- * Forms
- * News
- * Publications
- * Rules & Guidance
- * Statutes

Air Resource Management

Air Compliance & Enforcement Search (ACES)

Facility Detail Report

[Glossary](#)

Report Date: 5/14/2008

Facility Characteristics

[Glossary](#)

Owner/Company: **TOALE BROTHERS FUNERAL HOME**

Site Name: **TOALE BR'S FUNERAL HOME-CREMATORY**

Address: **912 53rd Ave W
Bradenton FL 34207**

Facility ID: **0810039**

Facility is currently **IN** Compliance

SIC Code: **7261 - Personal Services; Funeral Service And Crematories; Funeral Service And Crematories**

DEP Facility Type: **Human Crematory**

Regulatory Classifications:

Applicable Federal Rules - Include:

Status: **Active**

Active Permits and Authorizations

[Glossary](#)

ID Number	Type	Sub Type Description	Project Name	Issued / Effective	Expiration Date
0810039-003-AG	General Permit	Non-Title V GP	HUMAN CREMATORY GP	05/23/2003	05/23/2008
0810039-004-AG	General Permit	Non-Title V GP	TOALE BR'S FUNRL HOME-CREMATOR	05/03/2008	05/03/2013

5 Year Summary

[Glossary](#)

Number of Inspections	Date of Last Inspection	Formal Enforcement Actions	Penalties Assessed
4	11/20/2007	0	\$0.00

Formal Enforcement Actions (and Penalties Assessed) may have been for violations discovered more than 5 years ago.

5 Year Inspection History

[Glossary](#)

Date	Responsible Office	Inspection Type	Inspection Description	Facility in Compliance at Time of Inspection?
02/18/2004	SWD	INS2	Compliance Inspection	Yes
06/27/2006	SWD	INS2	Compliance Inspection	Yes
11/16/2006	SWD	INS2	Compliance Inspection	Yes
11/20/2007	SWD	INS2	Compliance Inspection	Yes

5 Year Compliance and Enforcement History

[Glossary](#)

Date Violation Discovered	Discovery Method	Dollars Assessed	Environmental Project Dollars	Total Penalty Assessed
There were no violations discovered at this facility in the last 5 years.				

**HUMAN CREMATORY
AIR GENERAL PERMIT REGISTRATION FORM**

Part II. Notification to Permitting Office

(Detach and submit to appropriate permitting office; keep copy onsite)

Instructions: To give notice to the Department of an eligible facility's intent to use this air general permit, the owner or operator of the facility must detach and complete this part of the Air General Permit Registration Form and submit it to the appropriate Department of Environmental Protection or local air pollution control program office which has permitting authority. Please type or print clearly all information, and enclose the appropriate air general permit registration processing fee pursuant to Rule 62-4.050(4)(o), F.A.C. (\$100 as of the effective date of this form)

Registration Type

Check one:

INITIAL REGISTRATION - Notification of intent to:

- Construct and operate a proposed new facility.
- Operate an existing facility not currently using an air general permit (e.g., a facility proposing to go from an air operation permit to an air general permit).

RE-REGISTRATION (for facilities currently using an air general permit) - Notification of intent to:

- Continue operating the facility after expiration of the current term of air general permit use.
- Continue operating the facility after a change of ownership.
- Make an equipment change requiring re-registration pursuant to Rule 62-210.310(2)(e), F.A.C., or any other change not considered an administrative correction under Rule 62-210.310(2)(d), F.A.C.

Surrender of Existing Air Operation Permit(s) - For Initial Registrations Only

If the facility currently holds one or more air operation permits, such permit(s) must be surrendered by the owner or operator upon the effective date of this air general permit. In such case, check the first box, and indicate the operation permits being surrendered. If no air operation permits are held by the facility, check the second box.

- All existing air operation permits for this facility are hereby surrendered upon the effective date of this air general permit; specifically permit number(s): _____
- No air operation permits currently exist for this facility.

General Facility Information

Facility Owner/Company Name (Name of corporation, agency, or individual owner who or which owns, leases, operates, controls, or supervises the facility.)

TOALE BROTHERS FUNERAL HOME

Site Name (Name, if any, of the facility site; e.g., Plant A, Metropolis Plant, etc. If more than one facility is owned, a registration form must be completed for each.)

BRADENTON FACILITY

Facility Location (Provide the physical location of the facility, not necessarily the mailing address.)

Street Address: **912 53RD AVE. WEST**

City: **BRADENTON**

County: **MANATEE**

Zip Code: **34207**

Facility Start-Up Date (Estimated start-up date of proposed new facility.) (N/A for existing facility)

N/A

Owner/Authorized Representative

Name and Position Title (Person who, by signing this form below, certifies that the facility is eligible to use this air general permit.)

Print Name and Title: **JEFFREY TOALE, OWNER**

Owner/Authorized Representative Mailing Address

Organization/Firm: **TOALE BROTHERS FUNERAL HOME**

Street Address: **P. O. DRAWER T**

City: **SARASOTA**

County: **SARASOTA**

Zip Code: **34230**

Owner/Authorized Representative Telephone Numbers

Telephone: **941-955-4171**

Fax: **941-751-3760**

Cell phone (optional):

Facility Contact (If different from Owner/Authorized Representative)

Name and Position Title (Plant manager or person to be contacted regarding day-to-day operations at the facility.)

Print Name and Title: **SAME AS ABOVE**

Facility Contact Mailing Address

Organization/Firm:

Street Address:

City:

County:

Zip Code:

Facility Contact Telephone Numbers

Telephone:

Fax:

Cell phone (optional):

Owner/Authorized Representative Statement

This statement must be signed and dated by the person named above as owner or authorized representative

I, the undersigned, am the owner or authorized representative of the owner or operator of the facility addressed in this Air General Permit Registration Form. I hereby certify, based on information and belief formed after reasonable inquiry, that the facility addressed in this registration form is eligible for use of this air general permit and that the statements made in this registration form are true, accurate and complete. Further, I agree to operate and maintain the facility described in this registration form so as to comply with all applicable standards for control of air pollutant emissions found in the statutes of the State of Florida and rules of the Department of Environmental Protection and revisions thereof.

I will promptly notify the Department of any changes to the information contained in this registration form.

Jeff G Toale
Signature

April 16, 2010
Date

**CALCULATIONS FOR PRODUCTS OF COMBUSTION
AND RESIDENCE TIME FOR 150 LB/hr
TYPE IV WASTE. B&L PHOENIX II SERIES CREMATORY**

NATURAL GAS

A. BASIS: 1 LB WASTE

1. $\frac{1 \text{ lb waste} \times 1000 \text{ Btu/lb waste} \times 15 \text{ lbs air}}{10,000 \text{ Btu}} = 1.5 \text{ lbs air}$
2. $\frac{1 \text{ lb waste} \times 0.10 \text{ lb combustible}}{1 \text{ lb waste}} = 0.10 \text{ lbs of combustibles}$
3. $\frac{1 \text{ lb waste} \times 0.85 \text{ lb H}_2\text{O} \times 1.6^*}{1 \text{ lb waste}} = 1.36 \text{ lbs of water}$
4. $\frac{6,500 \text{ Btu aux fuel}^{**} \times 10.0 \text{ cu ft air/cu ft fuel}}{1,050 \text{ Btu/cu ft fuel} \times 13.35 \text{ cu ft air/lb air @ 70f}} = 4.64 \text{ lbs of air for aux fuel}$
5. $\frac{6,500 \text{ Btu aux fuel} \times 0.044 \text{ lb fuel/cu ft fuel}}{1,050 \text{ Btu/cu ft fuel}} = 0.11 \text{ lb of aux fuel}$
6. Sum = PRODUCTS OF COMBUSTION (POC) = 7.86 lbs POC per lb waste @ 70f

B. RESIDENCE TIME @ 1600 F

1. $\frac{7.86 \text{ lbs POC/lbs waste} \times 51.89 \text{ cu ft / lb POC @ 1600f} \times 150 \text{ lbs waste / hr}}{3600 \text{ sec/hr}}$
 $= 16.99 \text{ cu ft / sec @ 1600 f} = 17.00 \text{ cu ft for 1 second residence time}$

RESIDENCE TIME @ 1800 F

2. $\frac{7.86 \text{ lbs POC/lbs waste} \times 56.93 \text{ cu ft /lb POC @ 1800f} \times 150 \text{ lbs waste / hr}}{3600 \text{ sec/hr}}$
 $= 18.64 \text{ cu ft / sec @ 1800f} = 19.00 \text{ cu ft for 1 second residence time}$

* Correction multiplier for dry air and water vapor

** Fuel is natural gas

Referances: Incinerator institute of America.
 North American Combustion Handbook
 Eclipse Combustion Engineering guide

C. THERMOCOUPLE PLACEMENT.

Secondary chamber operating temperature at > or = to 1600f = 17.00 cu ft from flame tip.
 1800f = 19.00 cu ft from flame tip.



Cremation
Systems, Inc.

7205 - 114th Avenue North • Largo, Florida 33773
1-800-622-5411 • 727-541-4666 • Facsimile 727-547-0669
e-mail: blcremsys@aol.com • www.blcremationsystems.com

PROCESS DESCRIPTION

This project consists of the construction of one new cremation retort. This crematorium will consist of one B & L Systems Model Phoenix II-1 Human Cremator. The cremation unit will be fired on natural gas.

Deceased human remains are manually placed into the primary chamber of the cremator. The door of the cremator is then closed. After a preheat of the afterburning chambers by the auxiliary burner, initial and supplementary combustion is provided by natural gas fired burner located in the primary chamber of the cremator. Once material combustion is initiated, the rate of the combustion is controlled by limiting both the combustion air and fuel supplied to the primary chamber through the primary burner. This process generates a highly combustible gas mixture that flows into a secondary chamber where more air is admitted to insure further oxidation of the gases. The auxiliary burner is installed in the secondary chamber of the cremator to facilitate complete combustion of all gaseous materials entering this chamber.

Once the cremation process is complete, the remains are removed from the primary chamber of the cremator. These remains are placed in urns and returned to the family for interment or disposal.



Bl Cremation Systems, Inc.

7205 - 114th Avenue North • Largo, Florida 33773
 1-800-622-5411 • 727-541-4666 • Facsimile 727-547-0669
 e-mail: blcremsys@aol.com • www.blcremationsystems.com

PROCESS FLOW DIAGRAM

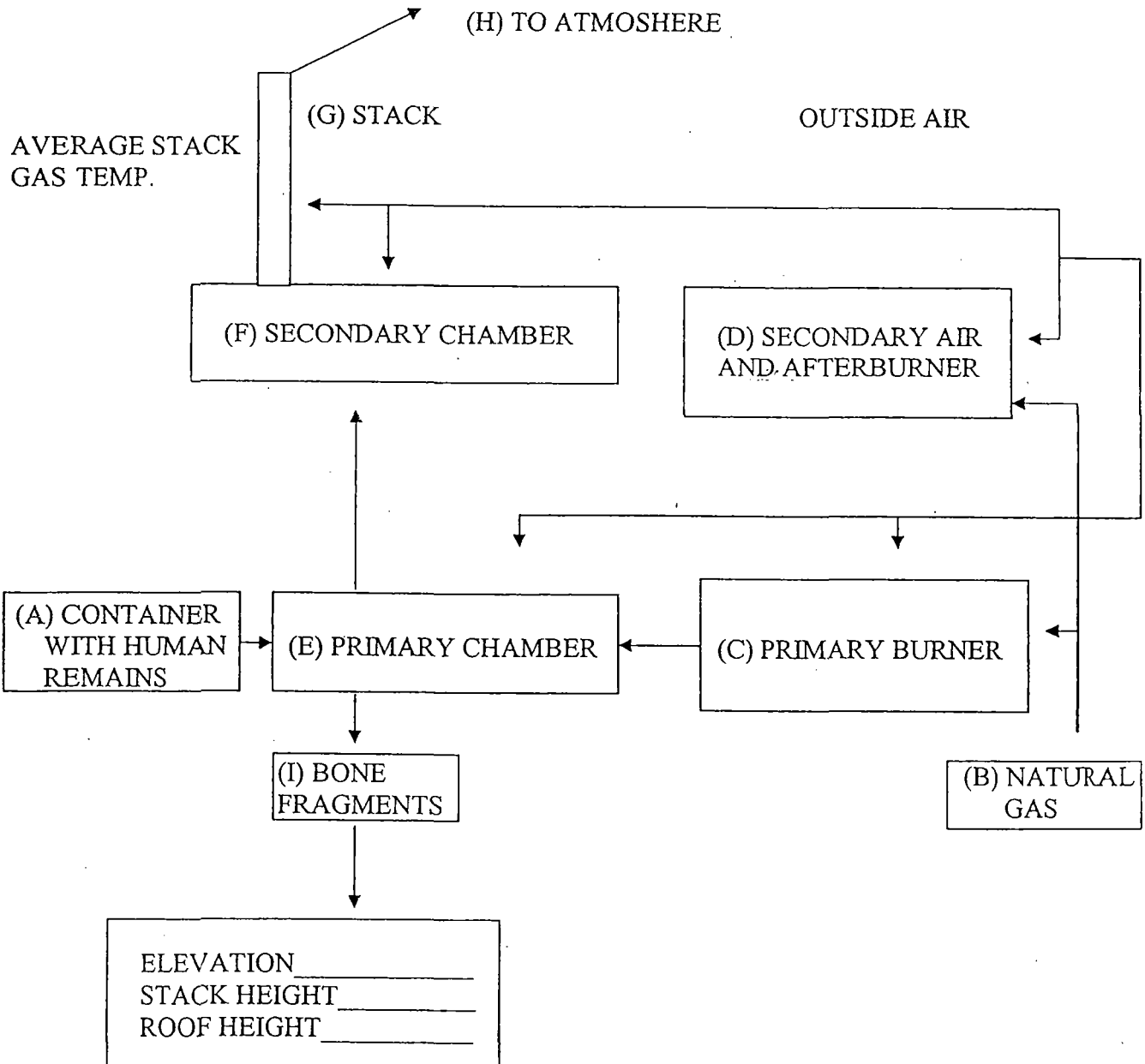

World's Largest Independent Cremation Equipment Manufacturer



Cremation
Systems, Inc.

7205 - 114th Avenue North • Largo, Florida 33773
1-800-622-5411 • 727-541-4666 • Facsimile 727-547-0669

TEMPERATURE CONTROL SEQUENCE

A type "K" thermocouple is placed 19³ ft. down stream of the flame tip to measure temperature, the signal is sent to the *main control panel* where it is received by a FUJI PYZ series temperature controller with digital readout and a DR4200 *temperature recorder*. The FUJI PYZ series temperature controller controls the temperature via a *motorized butterfly valve* located on the *afterburner inlet gas assembly*. Gas demand is controlled by temperature to maintain a steady temperature. The *ignition/cremation burner* is interlocked to the *afterburning temperature* by the FUJI PYZ series temperature controller set point. Combustion cannot start until *temperature set point* is reached. Alarm contacts in the FUJI PYZ series temperature controller are utilized for over (high) temperature conditions. 100° F over set point the *afterburner* will be in maximum low fire and the *ignition/cremation burner* will shut off. The *butterfly valve* located on the *secondary air inlet* is controlled by a separate temperature out put to add air to cool the system. At *set point* the unit will return to normal operation. An optimonitor smoke detector is placed on the stack and set at 10% opacity if emissions occur the alarm will sound; a visual *red warning lamp* located on the *control panel* will illuminate and the *primary burners* will shut off. The *excess air butterfly valve* will open to add air to the *secondary chamber* to oxidize the emissions. After a five (5) minute period the unit will revert to normal operation.

AFTERBURNER

B & L SYSTEMS N20 SERIES

SECONDARY AIR

30"

24"

40"

THERMOCOUPLE LOCATION

120"

20.0 FT³

SHADED AREA REPRESENTS AFTERBURNER CHAMBER VOLUME OF
83.00 FT³ @ 1800°F



Cremation
Systems, Inc.

7205 - 114th Avenue North • Largo, Florida 33773
1-800-622-5411 • 727-541-4666 • Facsimile 727-547-0669

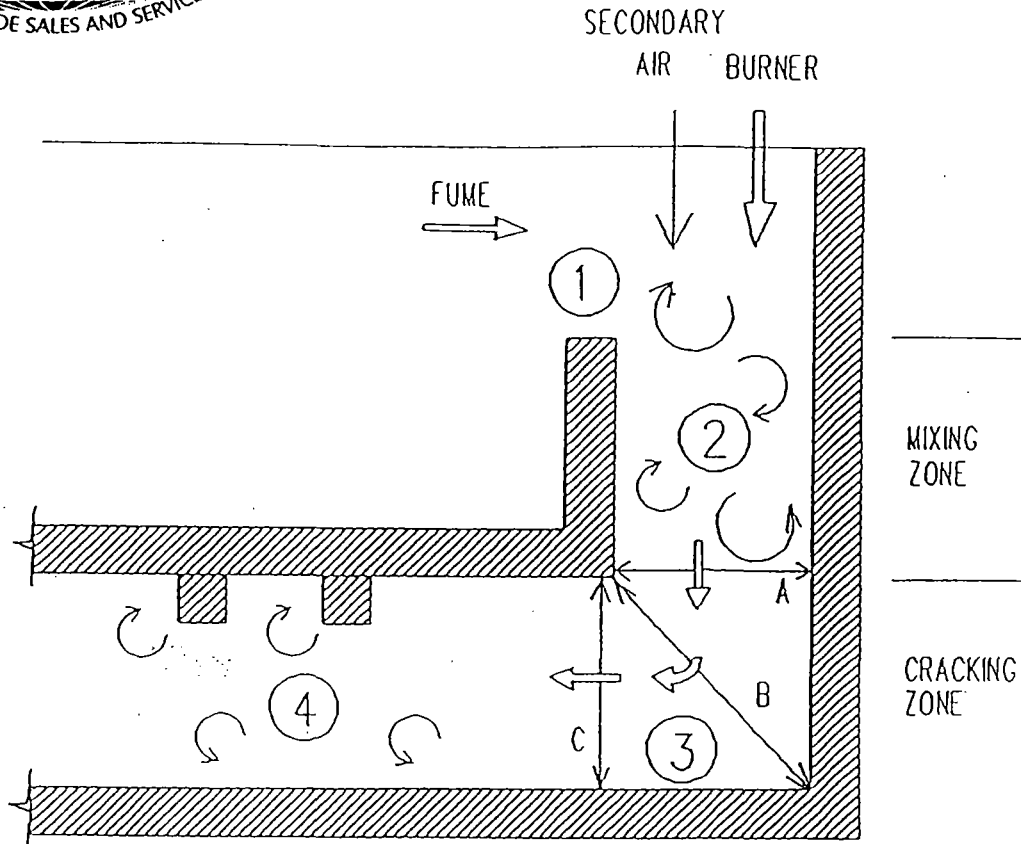

1. At the back of primary chamber, waste fume, air and burner flame all meet with different viscosities, volumes, velocities and flow directions which causes turbulence in the mixing zone of the secondary chamber.
2. Turbulence continues in the mixing zone as flows are traversing the flame tip.
3. Changing velocity at flame front zone and cornering cause additional turbulence at the base of the unit. $V_A > V_B < V_C$.
4. Uneven cross sectional area due to arches in the ceiling to support the primary chamber floor and additional changes in directional flow causes further turbulence downstream in the secondary chamber.

World's Largest Independent Cremation Equipment Manufacturer

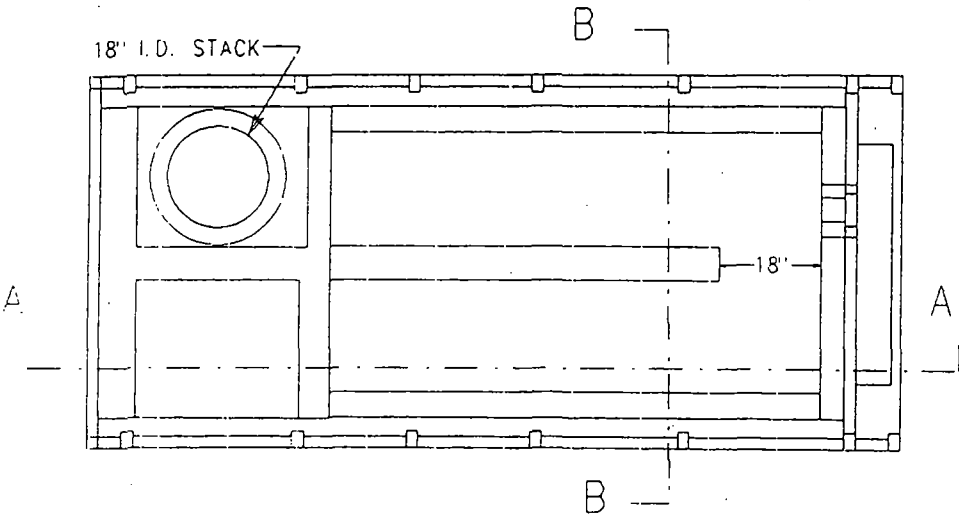
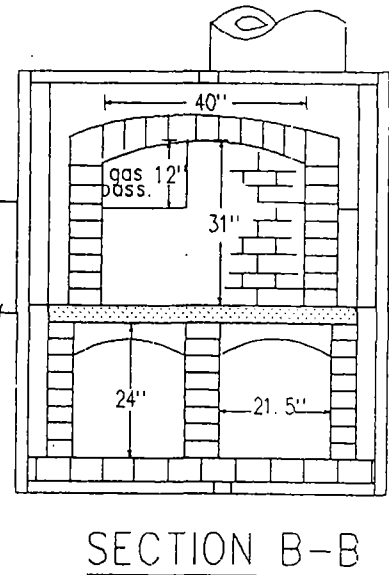
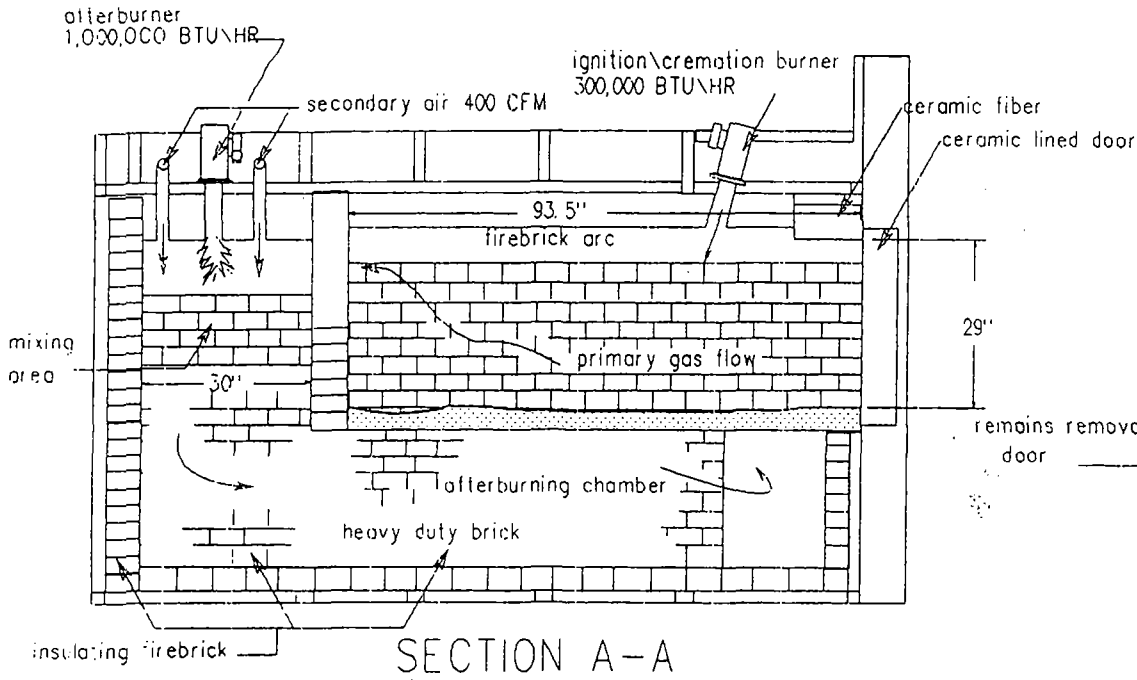

PLAN VIEW THRU CHAMBERS

ALL COMPONENTS U.L. AND/OR A.G.A. APPROVED
C.S.A. - C.G.A

PHOENIX II-1

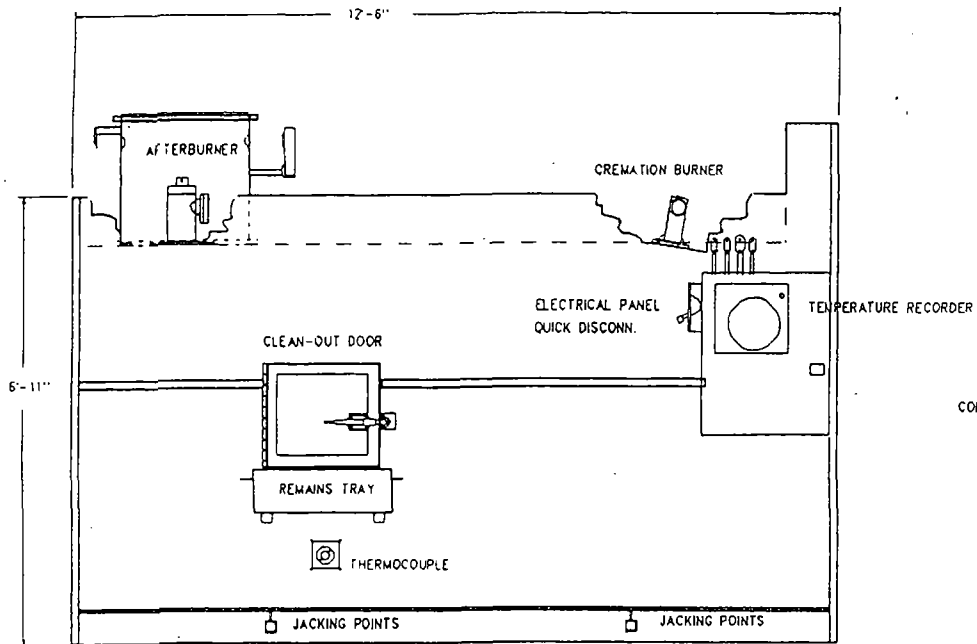

SIDE ELEVATION

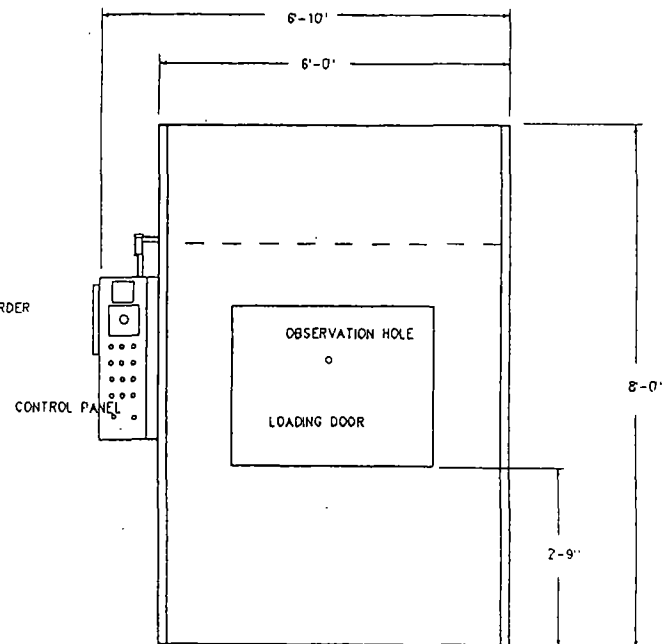

FRONT ELEVATION

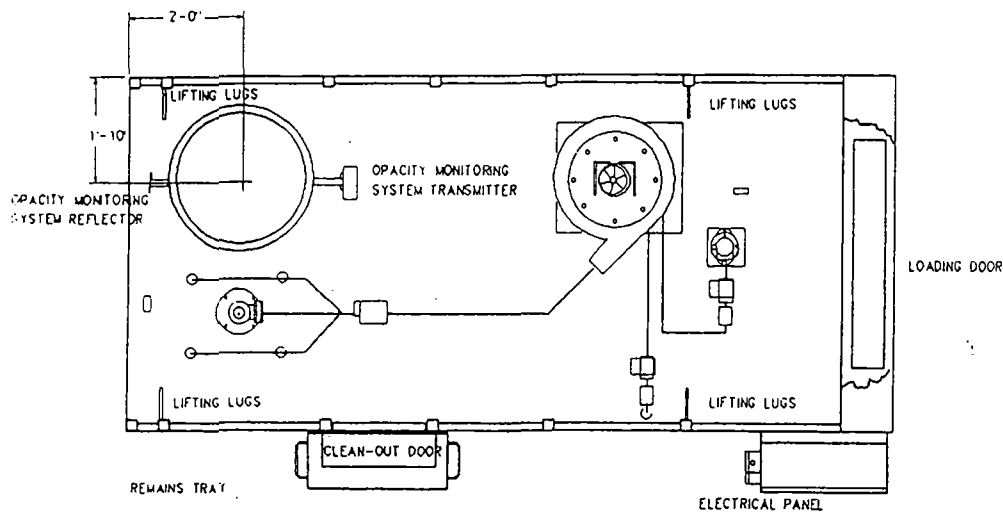

PLAN VIEW

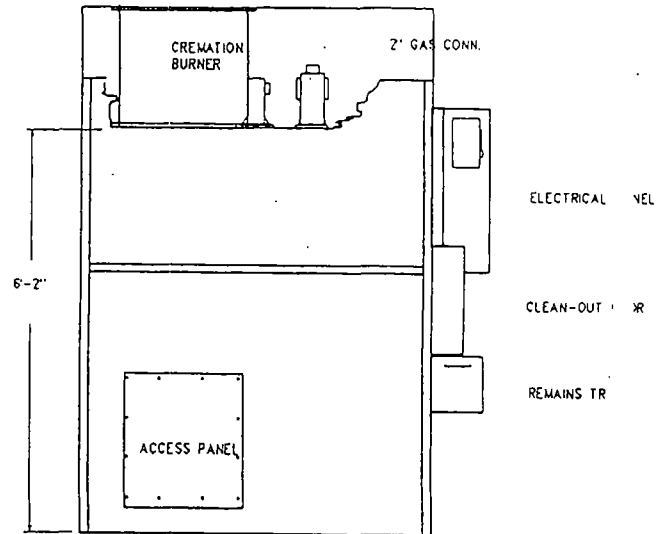

REAR ELEVATION

PHOENIX II-1

Table 5.5-5
ELEMENTAL CONTENT OF BODY FAT AND
BODY WATER

Component	Mass (g)	Carbon Quantity* (g)	Hydrogen Quantity* (g)	Oxygen Quantity* (g)
Body fat	13,500	1.0E + 4	1.6E + 3	1.5E + 3
Essential	1,500	1.2E + 3	1.8E + 2	1.7E + 2
Nonessential	12,000	9.2E + 3	1.4E + 3	1.3E + 3
Body water	42,000		4.6E + 3	3.7E + 4
Extracellular	18,000		20.E + 3	1.6E + 4
Intracellular	24,000		2.6E + 3	2.1E + 4

* For sources, see Reference 1.

From Snyder, W. S., Cook, M. J., Karhausen, L. R., Nasset, E. S., Howells, G. P., and Tipton, I. H., *Report of the Task Force on Reference Man*, ICRP Report No. 23, International Commission on Radiological Protection, Pergamon Press, Oxford, 1975, 1. With permission.

Table 5.5-6
REFERENCE MAN: TOTAL BODY CONTENT FOR SOME ELEMENTS

Element	Amount (g)	Percent of total body weight	Element	Amount (g)	Percent of total body weight
Oxygen	43,000	61	Lead	0.12	0.00017
Carbon	16,000	23	Copper	0.072	0.00010
Hydrogen	7,000	10	Aluminum	0.061	0.00009
Nitrogen	1,800	2.6	Cadmium	0.050	0.00007
Calcium	1,000	1.4	Boron	<0.048	0.00007
Phosphorus	780	1.1	Barium	0.022	0.00003
Sulfur	140	0.20	Tin	<0.017	0.00002
Potassium	140	0.20	Manganese	0.012	0.00002
Sodium	100	0.14	Iodine	0.013	0.00002
Chlorine	95	0.12	Nickel	0.010	0.00001
Magnesium	19	0.027	Gold	<0.010	0.00001
Silicon	18	0.026	Molybdenum	<0.0093	0.00001
Iron	4.2	0.006	Chromium	<0.0018	0.000003
Fluorine	2.6	0.0037	Cesium	0.0015	0.000002
Zinc	2.3	0.0033	Cobalt	0.0015	0.000002
Rubidium	0.32	0.00046	Uranium	0.00009	0.0000001
Strontium	0.32	0.00046	Beryllium	0.000036	
Bromine	0.20	0.00029	Radium	3.1×10^{-11}	

From Snyder, W. S., Cook, M. J., Karhausen, L. R., Nasset, E. S., Howells, G. P., and Tipton, I. H., *Report of the Task Group on Reference Man*, ICRP Report No. 23, International Commission on Radiological Protection, Pergamon Press, Oxford, 1975, 1. With permission.

Instruction Manual

No. 205, 11/95

Eclipse Velocity Burners

ThermJet Series (version 1.0)

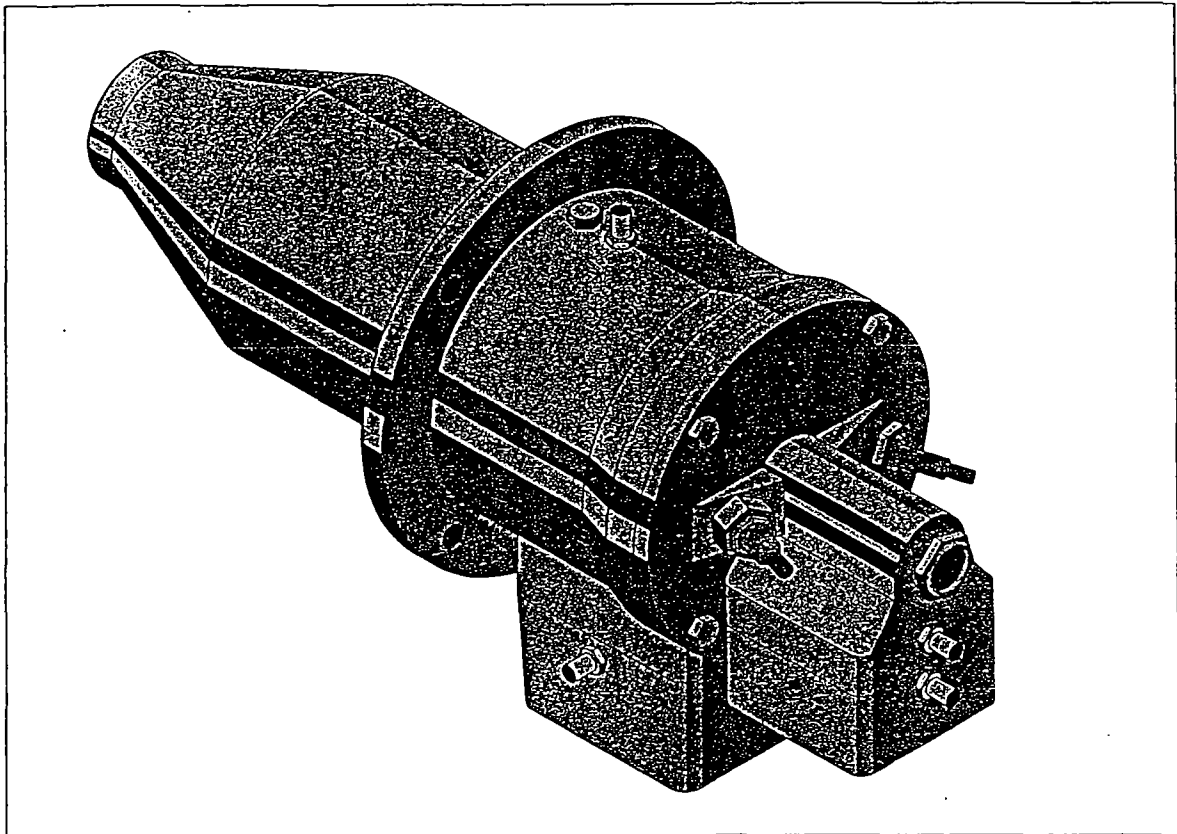

Eclipse

Eclipse Combustion

Specifications

3

INTRODUCTION

This section gives a detailed overview of the burner specifications. It also lists several options that are available for the ThermJet.

Figure 3.1 The ThermJet burner

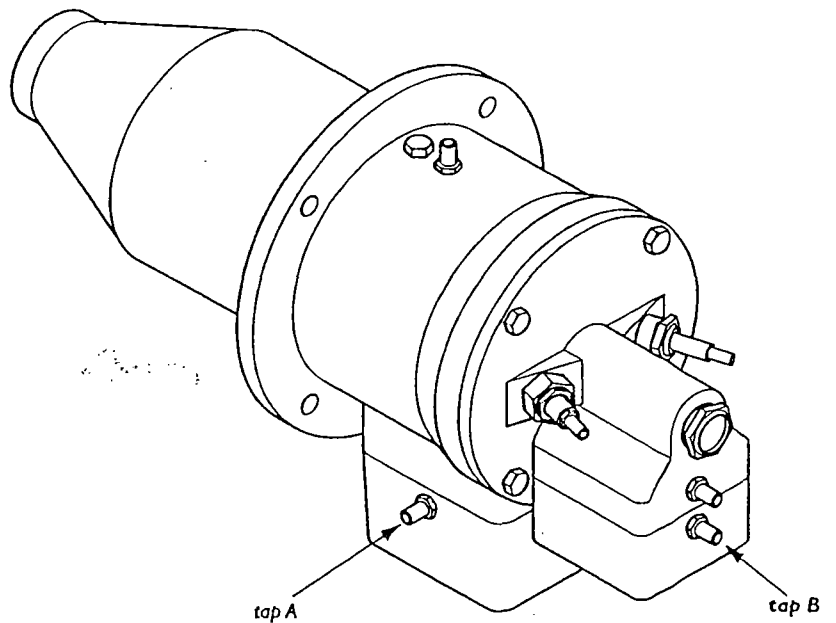

Table 3.1 Options

PARAMETER	OPTIONS
Fuel	<ul style="list-style-type: none"> • natural gas • propane • butane. <p style="text-align: right;"><i>For any other mixed gas, contact Eclipse for orifice sizing.</i></p>
Flame detection	<ul style="list-style-type: none"> • U.V. scanner • flame rod, for use with alloy or silicon carbide firing tubes only.
Ignition	<ul style="list-style-type: none"> • direct spark ignition (6 kV AC).
Combustor	<ul style="list-style-type: none"> • alloy firing tube • silicon carbide firing tube • refractory block.

SPECIFICATIONS

Main specifications

Table 3.2 ThermJet performance data

PARAMETER	BURNER TYPE (VELOCITY)	BURNER SIZE				
		50	75	100	150	
High fire input (Btu/hr)	Medium & High velocity	500,000	750,000	1,000,000	1,500,000	
Low firing rate, on-ratio (Btu/hr)	Medium & High velocity	50,000	75,000	100,000	150,000	
Low firing rate, fixed air (Btu/hr)	Medium & High velocity	10,000	15,000	20,000	30,000	
Static air pressure ("w.c.) • 15% excess air, at maximum input with standard orifice plate installed. measured at tap A (See Figure 3.1)	High velocity	12.0	16.0	14.5	18.5	
	Medium velocity	7.5	8.0	7.5	9.5	
Static gas pressure ("w.c.) • at maximum input with standard orifice plate installed. measured at tap B (See Figure 3.1)	High velocity	11.0	15.5	16.0	16.5	
	Medium velocity	6.0	6.5	7.5	8.0	
Flame length (In) (from end of firing tube)	High velocity	Nat. gas	25	30.4	33	38
		Propane	33	34	34	42
		Butane	30	30	35	43
	Medium velocity	Nat. gas	28	28	38	43
		Propane	36	38	37	42
		Butane	39	30	42	40
Maximum flame velocity (ft/s) • 15% excess air, at maximum input	High velocity	500	500	500	500	
	Medium velocity	250	250	250	250	

- all information is given for general sizing purposes only
- refer to data sheet for burner specific information
- all inputs based on gross calorific values

Performance graphs

The graphs that follow give you an approximate picture of the performance. Should you want more exact information, contact Eclipse Combustion.

Figure 3.2 NO_x emissions

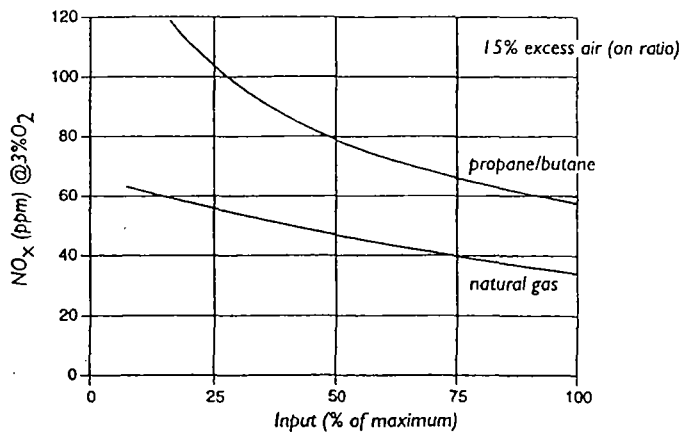

The emissions from the burner are influenced by:

- the fuel type
- the combustion air temperature
- the firing rate
- the chamber conditions
- the percent of excess air

For estimates of other emissions, contact Eclipse Combustion.

Figure 3.3 Operational zone

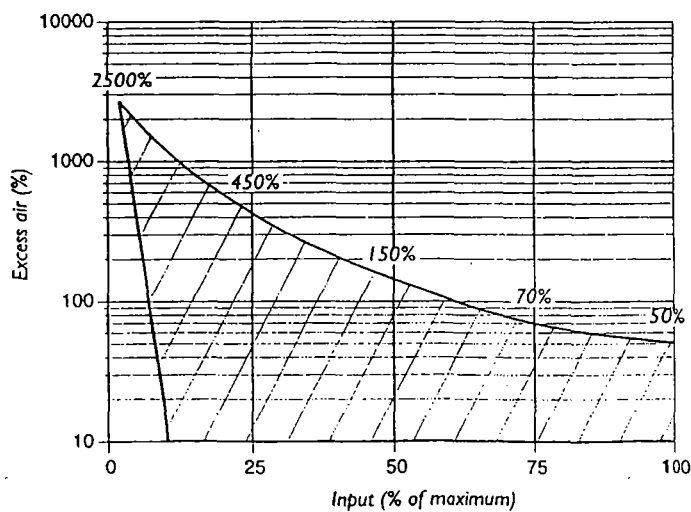

VISIBLE EMISSIONS ALARM (VEA)

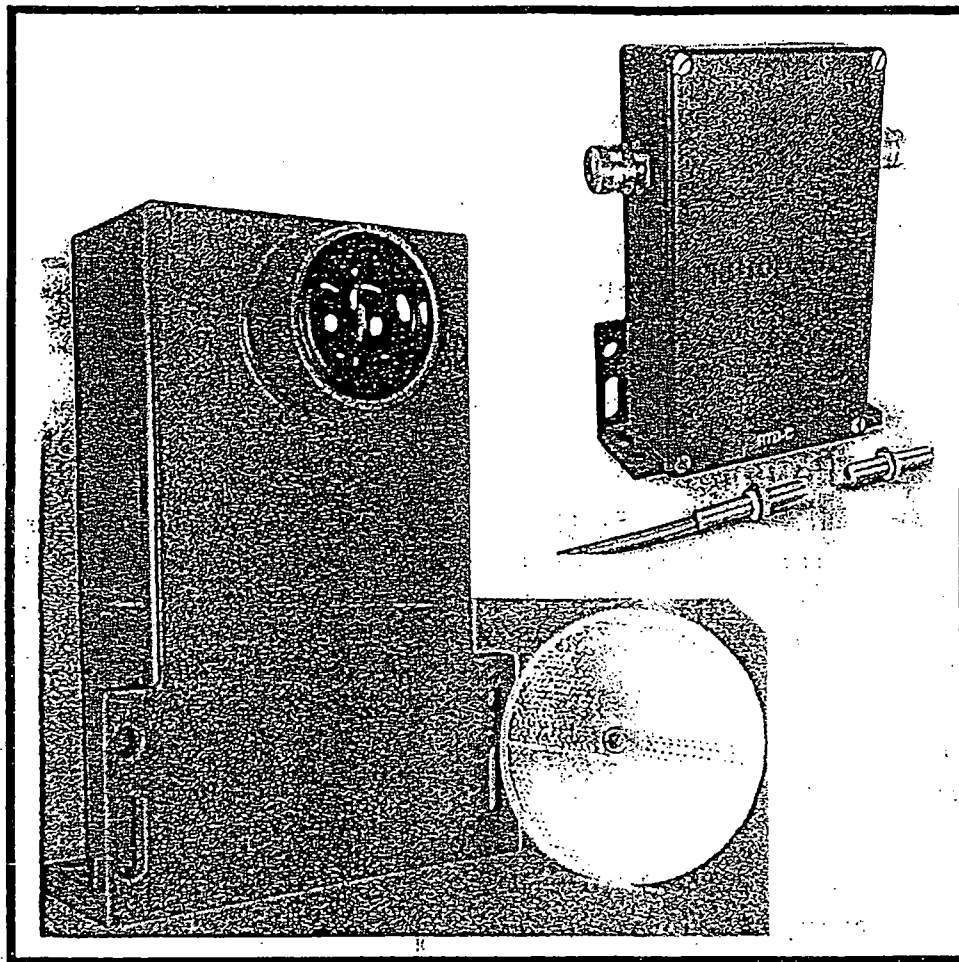

APPLICATION: Alarm and control for Opacity used on small and large sources for warning operators and shutting down systems based on opacity, haze or clarity.

- Proven Rugged Design
- Unaffected by Ambient Light
- Spans up to 6 Feet
- Visible LED Light Source
- Dual Beam or Single Beam
- Adjustable Delay up to 3 min.
- Easy to Install & Support
- External Adjustment

GENERAL PURPOSE OPACITY ALARMS

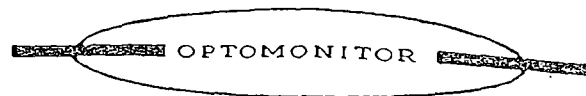

APPLICATION: These units are specifically designed to provide an operator with a reliable alarm system when Opacity or Smoke has exceeded a predefined limit. The alarm limit is easily set by using an opacity filter. The pulsed visible LED is unaffected by ambient light which makes for easy to install and calibrate.

FEATURES: The unit comes in either a single beam and dual beam design and an almost permanent LED light source. The electronics are housed in a rugged die-cast housing and powered by either 120 VAC or 230 VAC.

These designs meet all common installation requirements.

SPECIFICATIONS:

- LIGHT SOURCE:** Pulsed Visible LED.
- SPECTRAL RESPONSE:** Between 400nm & 500nm.
- ANGLE OF VIEW:** Less than 4 degrees from axis.
- AMBIENT LIGHT:** No measurable effect.

- RANGE:** 0 TO 100% Opacity.
- ACCURACY:** +/- 3% of full scale.
- ALARMS:** DPDT 5.0 A @ 120 VAC; 100% adj. LED indicator for alarm setting.
- OTHER OUTPUTS:** ON-OFF operation (no time delay).
 - OFF time delay (reverse of normal).
 - Adjustable One-shot.

- POWER:** 100-130 Volts AC, 50/60 Hz, 10 VA.
- TEMPERATURE:** Ambient: -20 to +150 degrees F.
Storage: +20 to +90 degrees F.
- ENCLOSURES:** Meet NEMA 3,4,5,12.
- PHYSICAL:** ELECTRONICS 8.0" x 5.75" x 3.31" (HWD).
 - VEA-S SINGLE BEAM - 3/8"-24 inch. Straight Thread.
 - VEA-D DUAL BEAM SENSOR - 3" Diameter.

- RESPONSE TIME:** Selectable & Adjustable up to 3 minutes.

OPTOMONITOR, Inc.
270 Polaris Avenue
Mountain View, CA 94043
Phone: 415/967-8992
Fax: 415/967-0286

PLACE
STAMP
HERE

ECLIPSE TURBO BLOWERS

SERIES "SMJ"

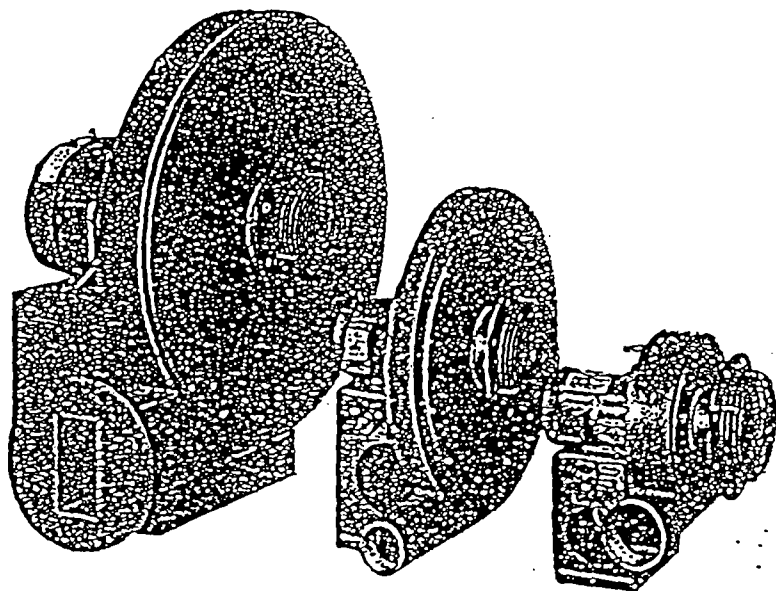

- High efficiency
- Heavy gauge steel base and housing
- Aluminum impellers balanced statically and dynamically
- Matching air filters available
- Changeable outlet positions

Eclipse "SMJ" Blowers are centrifugal blowers that provide low pressure air for industrial combustion systems. They are also used for cooling, conveying, drying, liquid agitation, smoke abatement, vacuum cleaning, fume and dust exhausting, and other applications where air temperatures are under 220°F.

All "SMJ" Blowers are constructed of continuous welded, heavy gauge steel. The impellers are made of lightweight, high strength, riveted aluminum. Outlets on 3" and 4" models are threaded, while all others are flanged for a standard 125# ANSI companion flange. Discharge ports are sized to keep pressure losses within reasonable limits.

Blower inlet flanges are equipped with a grill that complies with OSHA regulations. If desired, the grill may be removed and the inlet bolted to a standard ANSI companion flange. Eclipse-supplied motors are standard shaft and starting torque, ball bearing, 3600 rpm units. On any blower requiring 3/4 HP or more, Eclipse recommends that polyphase motors be used.

There are four possible outlet positions. Any existing position is easily changed by removing the housing from the

blower base and remounting it in the desired position. Positions 1 through 3 can be specified for any blower. Position 4, however, requires factory approval before ordering. Position 1 is the standard assembly (bottom, horizontal) unless otherwise specified.

"SMJ" Blowers can be supplied with counterclockwise (CCW) or clockwise (CW) rotation as viewed from the motor side. CCW rotation is furnished standard unless otherwise specified.

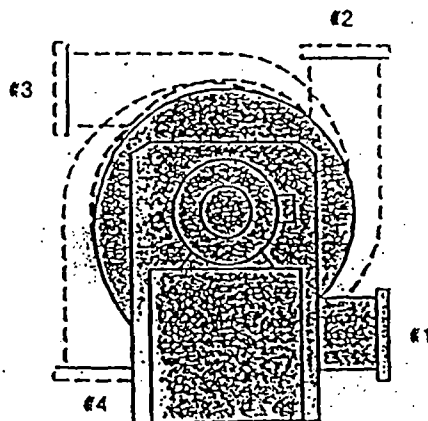

Outlet Positions

Orion Drawings:

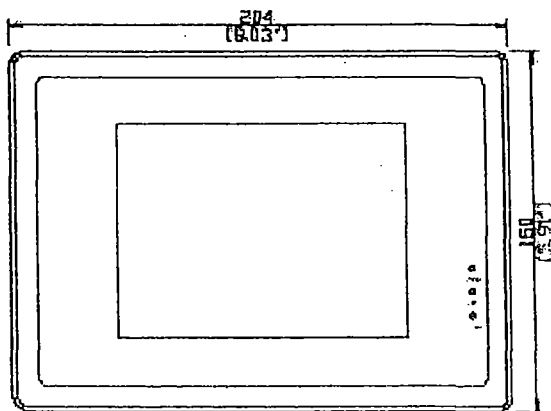

Front View

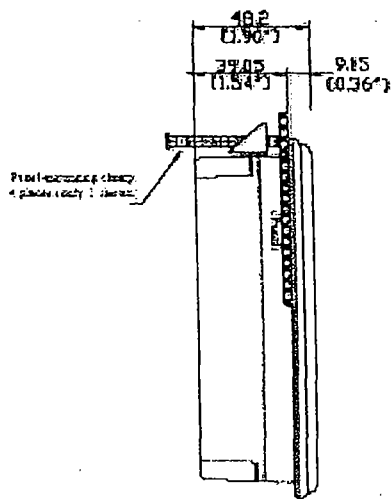

Side View

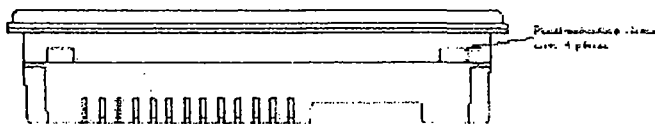

Bottom View

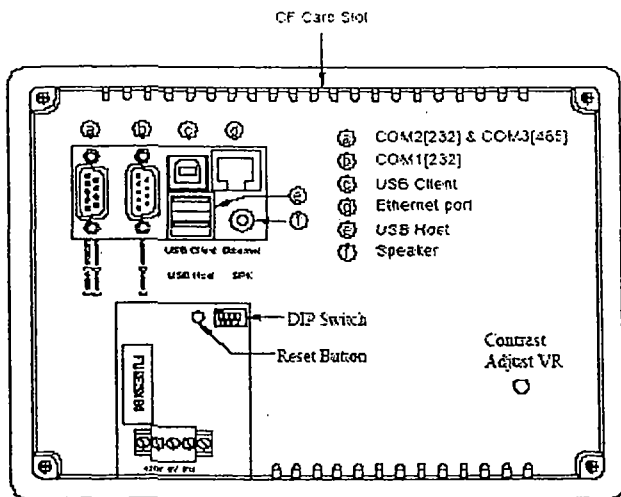

Rear View

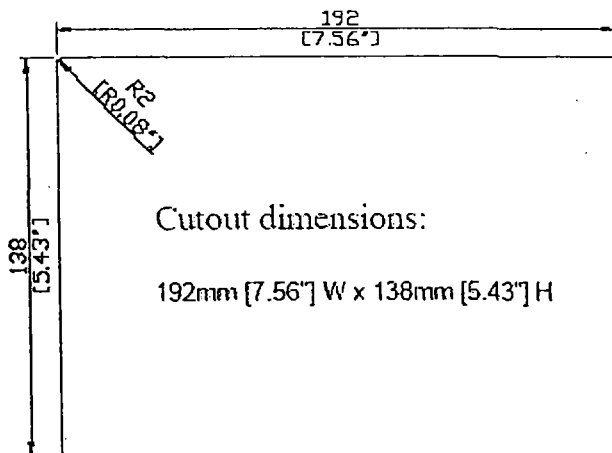

FUTUREDESIGN
C O N T R O L S

P.O Box 1196 * 7524 BridgeView, ILL 60455 * Phone: 888.751.5444 - Fax 888.245.2883

Power

24VDC - 500mA maximum current draw.

Display:

Display Type: STN Color LCD

Display Size: 5.7"

Max Colors: 4096

Resolution: 320 X 240

Pixel pitch (HxV,mm): 0.36 X 0.36

Luminance(cd/m²): 100

Storage Temp (C): -20 to 60

Operating Temp (C): 0 to 45

Backlight: 1 CCFL

Contrast Ratio: 30:1

Backlight life: Approx 40,000 hours

TouchScreen:

Type: 4 wire, analog resistive

Resolution: Continuous

Light transmission: above 80%

Life: 1 million activation minimal

Processor:

Type: Intel Xscale PXA255 200Mhz

Memory and OS:

Memory: 64MB of internal RAM

Operating System: Windows CE.net

Loop Interface:

Type: 300 series control/RS485 multi-drop interface

Max Loops: 20

Data Storage:

Type: 128 Mb compact flash

Connections:

Serial: Com1, 2 & 3 - RS232/RS485

Ethernet: 10 baseT

USB: 1 client - 2 host

Sound: 16 bit sound output

Physical:

Front Panel: Meets Nema4/IP65

Shock: 10 to 25Hz (X,Y,Z direction 2G, 30 mins)

Dimensions: 204" (H) x 150" (W) x 48" (D) - mm

Weight: 28.21.0 oz. (0.8 kg)

Orion interface ports (RS485, USB and Ethernet)

MicroSmart

The Next Generation of PLC

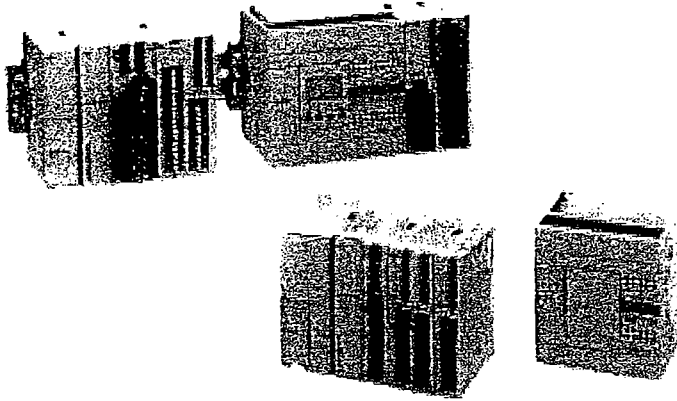

Key features of the MicroSmart series include:

- 10, 16, or 24 I/O All-in-one type CPU modules with Sink/Source DC input and Relay Output
- 20 I/O Slim type CPU modules with Sink/Source DC input and Transistor Sink or Source Output
- 20 I/O Slim type CPU modules with Sink/Source DC input and Relay Output with high-speed Transistor Sink or Source Output
- 40 I/O Slim type CPU modules with Sink/Source DC input and Transistor Sink or Source Output
- DC Input, Relay Output, Transistor Output, Combination I/O and Analog I/O expansion modules available
- 24 I/O All-in-one CPU expandable to 88 I/O points; 20 I/O slim types expandable up to 148 or 244 I/O; 40 I/O slim type expandable up to 264 I/O points
- Standard RS232 port, optional plug-in RS485/RS232 port
- Optional memory cartridge or real-time clock and calendar cartridge
- Data link to other MicroSmart modules, PLCs, PCs or HG series operator interfaces
- Approved for Class 1—Div. 2 hazardous locations (UL1604)
- Compact size
- Now available with AC input expansion module

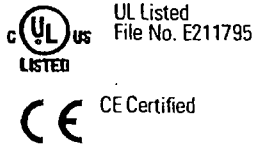

Pulse Output/Trapezoidal Control

Independent dual-axis control is available with two pulse outputs. Locational values can be easily defined for precise positional (trapezoidal) control.

- Pulse output instruction
- PWM instruction (Pulse Width Modulation control)

Pulse Output Function Specifications

Number of output points	2
Maximum output frequency	20 kHz

*Only one point of trapezoidal control is available.

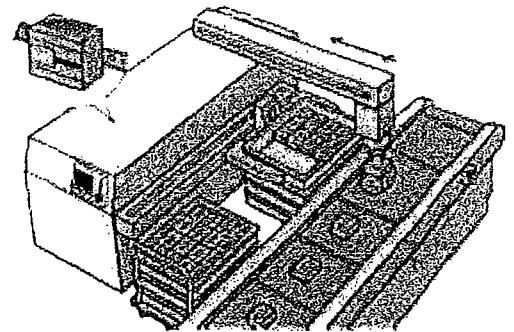
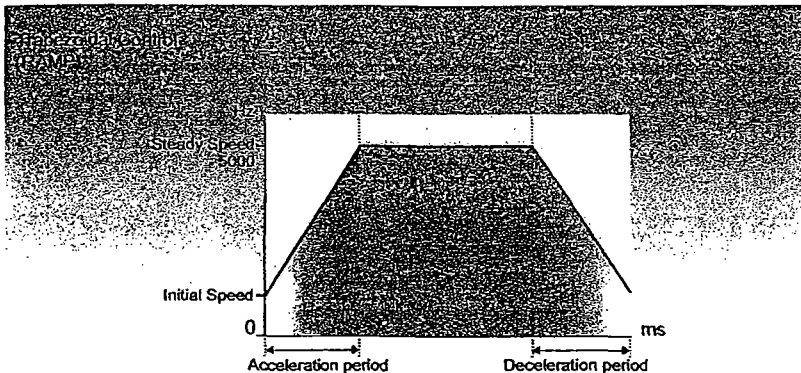

Setting the desired values enables you to precisely manage the trapezoidal control

Operation mode (S1)	1
Steady pulse frequency (S1 + 1)	50
Initial pulse frequency (S1 + 2)	10
Frequency change rate (S1 + 3)	2
Present value (S1 + 6, 7)	10,000

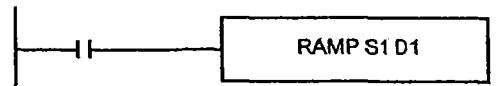

Programmable Logic Controllers

CPU and Module Combination Examples

All-In-One Type

- Attach Maximum 4 Expansion Modules
- Maximum I/O 88 points
- Only FC4A-C24R2/C24R2C CPU Module is expandable



The maximum number of relay outputs that can be turned on simultaneously is 33 points including relay outputs on the CPU module.

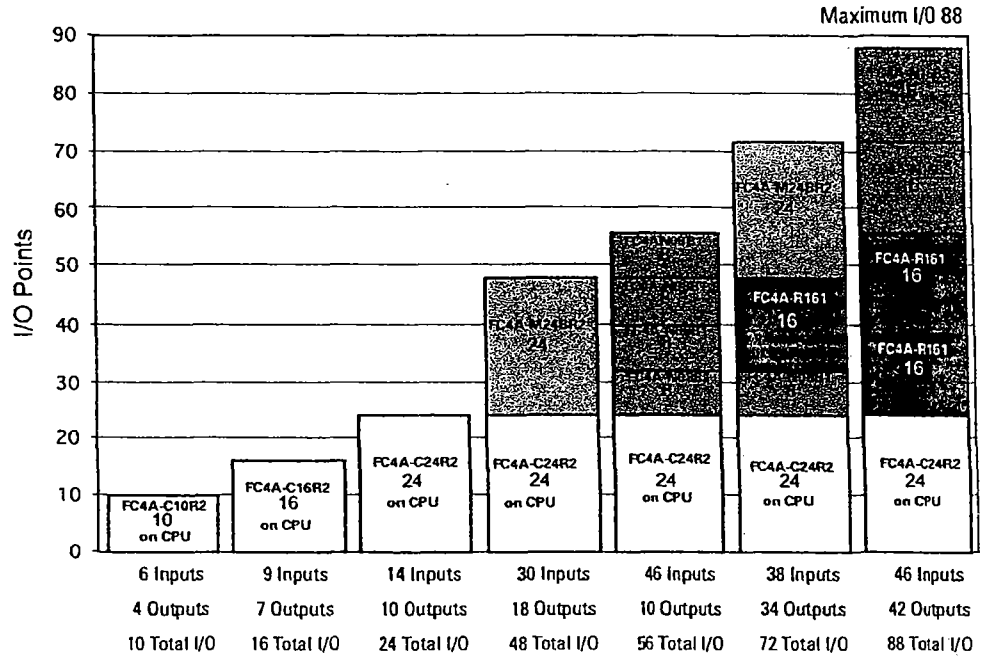

Slim Type



Programmable Logic Controllers

- Attach Maximum 7 Expansion Modules
- Maximum I/O
 - 148 points (D20K3, D20S3)
 - 244 points (D20RK1, D20RS1)
 - 264 points (D40K3, D40S3)



The maximum number of relay outputs that can be turned on simultaneously is 54 points including relay outputs on the CPU module.

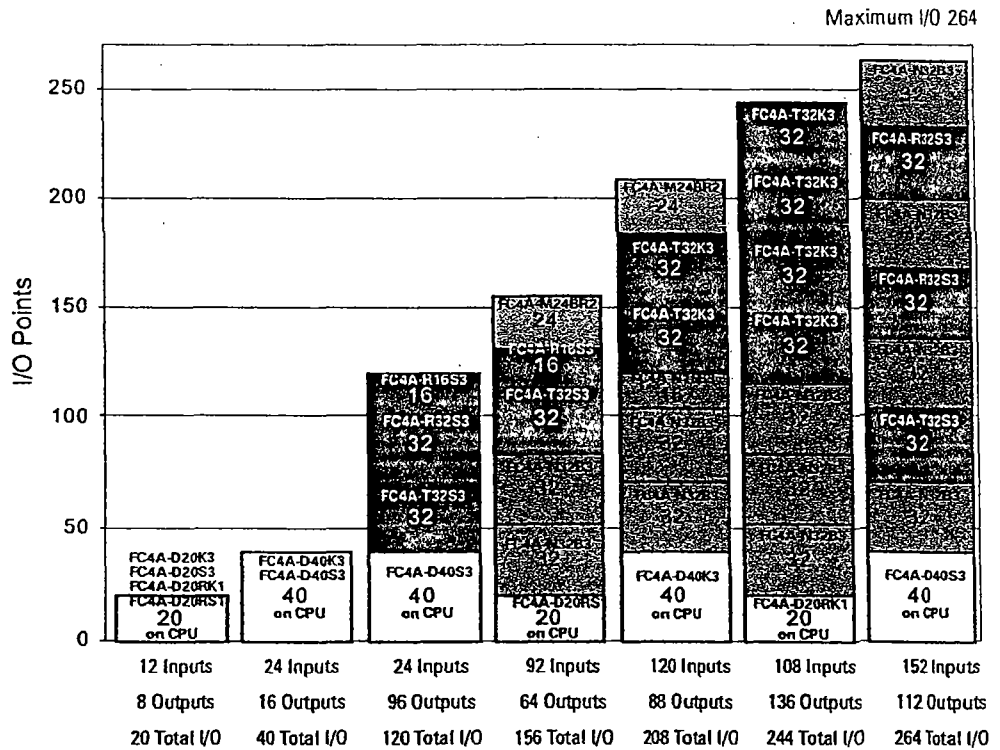

DIRECTORS SERVICE, INC.
3121 44th AVENUE NORTH
ST. PETERSBURG, FL 33714

AIR COMPLIANCE TEST REPORT

PERMIT NO. 1030035-001-AO

HUMAN CREMATORY

PREPARED FOR:

DIRECTORS SERVICE, INC.

ST. PETERSBURG, FLORIDA

JULY 26, 2005

PREPARED BY:

ATC

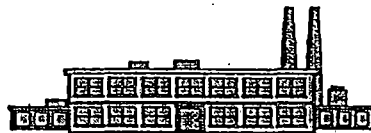

AIR TESTING & CONSULTING

333 FALKENBURG ROAD, SUITE B-214

TAMPA, FLORIDA 33619

ATC

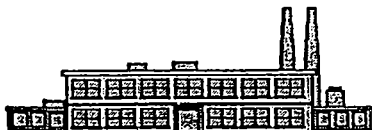

AIR TESTING & CONSULTING

333 FALKENBURG ROAD, SUITE B-214
TAMPA, FLORIDA 33619

To the best of my knowledge, all field and analytical procedures comply with Florida Department of Environmental Protection requirements and all test data and plant operating data are true and correct.

Kenneth E. Given

Kenneth E. Given, P.E.

8/1/05

Date

TABLE OF CONTENTS

- 1.0 INTRODUCTION
- 2.0 PROCESS DESCRIPTION
- 3.0 SUMMARY OF RESULTS
- 4.0 SUMMARY OF TEST DATA
- 5.0 SAMPLING PROCEDURES
 - 4.1 DESCRIPTION AND SKETCH OF SAMPLING EQUIPMENT
 - 4.2 PARTICULATE - EPA METHOD 5
 - 4.3 O₂ - EPA METHOD 3A
 - 4.4 CO - EPA METHOD 10
 - 4.5 TRAVERSE POINT LOCATIONS
- 6.0 ANALYTICAL PROCEDURES

APPENDICES

- A. FIELD DATA
- B. LABORATORY DATA
- C. CALCULATIONS
- D. CALIBRATION INFORMATION
- E. VISIBLE EMISSION READINGS
- F. PRODUCTION DATA
- G. PROJECT PARTICIPANTS

1.0 INTRODUCTION

1.0 INTRODUCTION

On July 26, 2005, Air Testing & Consulting, Inc. conducted the following tests on the human crematory located at Directors Services, Inc., St. Petersburg, Pinellas County:

- (1) Particulate Emission (EPA Methods 1 – 5)*
- (2) Carbon Monoxide (EPA Method 10)*
- (3) Visible Emissions (EPA Method 9)*

These tests were performed to determine if the incinerator was operating within the guidelines of Permit No. 1030035-001-AO, the Florida Department of Environmental Protection (FDEP) and Pinellas County Department of Environmental Management.

2.0 PROCESS DESCRIPTION

2.0 PROCESS DESCRIPTION

Directors Service, Inc. operates a biological waste incinerator designed to cremate human remains. The incinerator is a natural gas fired B&L Systems, Model Phoenix II unit. The afterburner for the incinerator operates at approximately 1600°F with at least a one-second retention time. The charge rate is one adult size body (>150 lbs) per burn cycle.

3.0 SUMMARY OF RESULTS

3.0 SUMMARY OF RESULTS

The results of the Particulate, Carbon Monoxide (CO) and Opacity (VE) emission testing are presented in the Regulatory Summary and Table I. The Particulate emissions averaged 0.0768 grains per dry standard cubic foot (gr/dscf), the CO emissions averaged 22 parts per million (ppmv), each corrected to 7% O₂. Opacity, highest six minute average, was 0%.

4.0 SUMMARY OF TEST DATA

SUMMARY OF TEST DATA

PLANT : DIRECTORS

UNIT : INCINERATOR

RUN NUMBERS :1, 2, 3

TEST DATE : 07/26/05

	#1	#2	#3	AVERAGES
DATE	07/26/2005	07/26/2005	07/26/2005	
START TIME	8:42	11:14	13:51	
END TIME	9:43	12:16	14:53	
STACK DIAMETER (INCHES)	18	18	18	
NOZZLE DIAMETER (INCHES)	0.500	0.500	0.500	
TEST TIME (MINUTES)	60	60	60	
NUMBER OF TEST POINTS PER RUN	24	24	24	
STACK GAS TEMPERATURE (°F)	875.4	926.7	946	916.0
STACK GAS MOISTURE (%)	9.41	9.55	9.26	9.4
STACK GAS MOLECULAR WEIGHT	28.87	28.85	28.89	28.9
STACK GAS VOLUME SAMPLED (CUBIC FEET)	34.140	35.790	34.740	34.890
VOLUME SAMPLED (SCF @ 68°F)	33.989	35.707	34.631	34.776
STACK GAS VELOCITY (FEET PER SECOND)	19.87	20.34	20.47	20.22
STACK GAS FLOW RATE (ACFM)	2106.4	2156.6	2170.1	2144.4
STACK GAS FLOW RATE (DSCFM @ 68°F)	755.0	743.3	740.1	746.1
PARTICULATE CONC (GRAINS/DSCF)	0.0413	0.0343	0.0470	0.0409
PARTICULATE CONC @ 7% O2, (GRAINS/DSCF)	0.0784	0.0665	0.0855	0.0768
PARTICULATE MASS RATE (LBS/HOUR)	0.267	0.222	0.304	0.264
CO CONC , ppm	21	8	6	12
CO CONC @ 7% O2, ppm	39	16	11	22
ISOKINETIC SAMPLING RATE, %I	97.26	103.78	101.09	

FIELD DATA AND SAMPLES UNDER THE CONTROL OF:

TIM CAPELLE

LABORATORY ANALYSIS UNDER THE CONTROL OF:

ATC

SOUTHERN ENVIRONMENTAL SCIENCES, INC.
EXCEL CALCULATION SHEET

Prepared By: Dr. Steve Looker
Date: 6/9/2009
Client: B & L Cremation Systems, Inc.
Project: Slack Test of a Model Phoenix II Crematory at Directors Crematory on 7/26/05
Description: Example calculations - 50% Excess Air Correction Factor
Project #: 1030035

From Emissions Test	Run 1	Run 2	Run 3		
	34.14	35.79	34.74	dcf	Vm Dry Cubic Feet of Gas Sampled
	30.1	30.1	30.1	in. Hg	Pbar Barometric Pressure
	528	528	528	Deg R	Tstd Standard Temperature, Degrees Rankin (68 deg F +460)
	29.92	29.92	29.92	in. Hg	Pstd Standard Pressure
	540.6	553.7	552.9	Deg R	Tm Gas Meter Temperature, Degrees Rankin
	1.049	1.041	1.118	in. H2O	Average Orifice Differential
	30.18	30.18	30.18	in. Hg	Pm Meter Pressure = Barometric Pressure + (Avg Orifice Differential/13.6)
	0.986	0.986	0.986		Y Dry Gas meter Correction Factor
	19.78	20.04	16.57	mg	Total Milligrams of Particulate Matter Collected
	21.00	8.00	6.00	ppm	Parts per million Carbon Monoxide
	13.6	13.7	13.3	%	Percent Oxygen
	5.6	5.6	5.6	%	Percent Carbon Dioxide
	0.00210	0.00080	0.00060	%	Percent Carbon Monoxide
	80.8	80.7	81.1	%	Percent Nitrogen

Calculations

	175.9	180.1	164.0	Percent Excess Air	Calculation: $((\%O_2 - 0.5\%CO) \times 100) / (0.264\%N_2 - (\%O_2 - 0.5\%CO))$
Partuculate	33.160	33.940	32.998	Dry Standard Cubic Feet Sampled (dscf)	Calculation: $Vm \times Y \times (Tsd \times Pm) / (Tm \times Pstd)$
	0.305	0.309	0.256	Grains of particulate collected	Calculation: $mg \times grains \text{ per pound} / (grams \text{ per pound} \times mg \text{ per gram})$
	0.009	0.009	0.008	Grains per dscf	Calculation: $Grains \text{ of Particulate Matter Collected} / dscf \text{ sampled}$
	0.017	0.017	0.014	Grains per dscf @50% Excess Air	Calculation: $Grains \text{ per dscf} \times (100 + \text{Percent Excess Air}) / 150$
Carbon Monoxide	21.00	8.00	6.00	Parts Per Million, PPM	EPA Method 10
	38.62	14.94	10.56	Parts Per Million, @50% Excess Air	Calculation: $PPM \times (100 + \text{Percent Excess Air}) / 150$

Conversion Factors

	7000	Grains per pound
	453.59	Grams per pound
	1000	mg per gram

Emissions Test Information

Manufacturer	B & L Systems, Inc.
Model No.	Phoenix II Crematory
Facility Tested	Directors Service, St. Petersburg, Florida
Test Date	July 26, 2005

REGULATORY SUMMARY
 DIRECTORS SERVICE, INC.
 HUMAN CREMATORY
 JULY 26, 2005

PERMIT NO. NEDS NO. ID #	EPA METHOD	METHOD DESCRIPTION	ACTUAL EMISSION RATE	ALLOWABLE EMISSION RATE	PROCESS RATE POUNDS PER HOUR	
					ACTUAL	PERMIT
1030035-001-AO	5	PARTICULATE gr/dscf @ 7% O2	0.077	0.080	172	>150
	10	CARBON MONOXIDE ppmv @ 7% O2	22	100		
	9	VISIBLE EMISSIONS % Opacity	0	5% except for 20% up to 3 min/hr		

**TABLE I
TEST SUMMARY
DIRECTORS SERVICE, INC.
HUMAN CREMATORY
JULY 26, 2005**

RUN #	% O₂	PARTICULATE GR/DSCF @ 7% O₂	CO ppmv @ 7% O₂	PROCESS RATE PPH
1	13.6	0.0784	38.9	180
2	13.7	0.0665	15.9	170
3	13.3	0.0855	11.2	165
AVG	13.5	0.0768	22.0	171.7

EMISSION TEST CALCULATIONS

COMPANY: Directors Service Crematory
 SOURCE: Phoenix II Series Crematory
 TEST DATE: 07/26/2005
 Data analyst: Ken Given

Run No.	CO (ppm)	Particulate (gr/dscf)	CO2 (%)	CO @ 12% CO2 (ppm)	Particulate @ 12% CO2 (ppm)
1	21.0	0.0413	5.60	45.0	0.089
2	8.0	0.0343	5.60	17.1	0.074
3	6.0	0.0470	5.60	12.9	0.101
Averages	11.7	0.0409	5.60	25.0	0.088

FORMULAS:

$$\text{CO (ppm) @ 12\% O}_2 = \text{Actual CO (ppm)} \times \frac{12}{\% \text{ CO}_2}$$

$$\text{Particulate (gr/dscf) @ 12\% CO}_2 = \text{Actual particulate (gr/dscf)} \times \frac{12}{\% \text{ CO}_2}$$



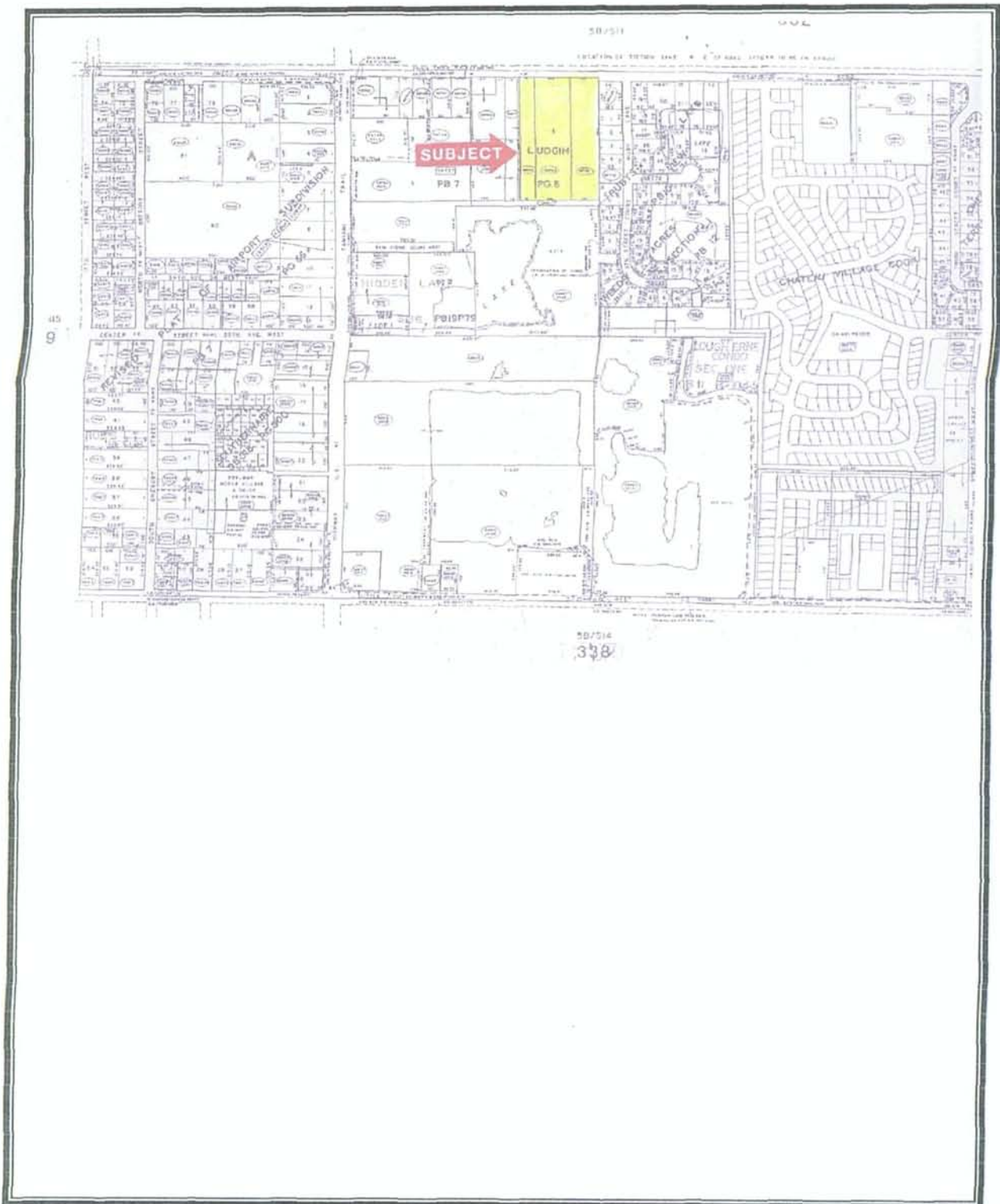

Tax Map

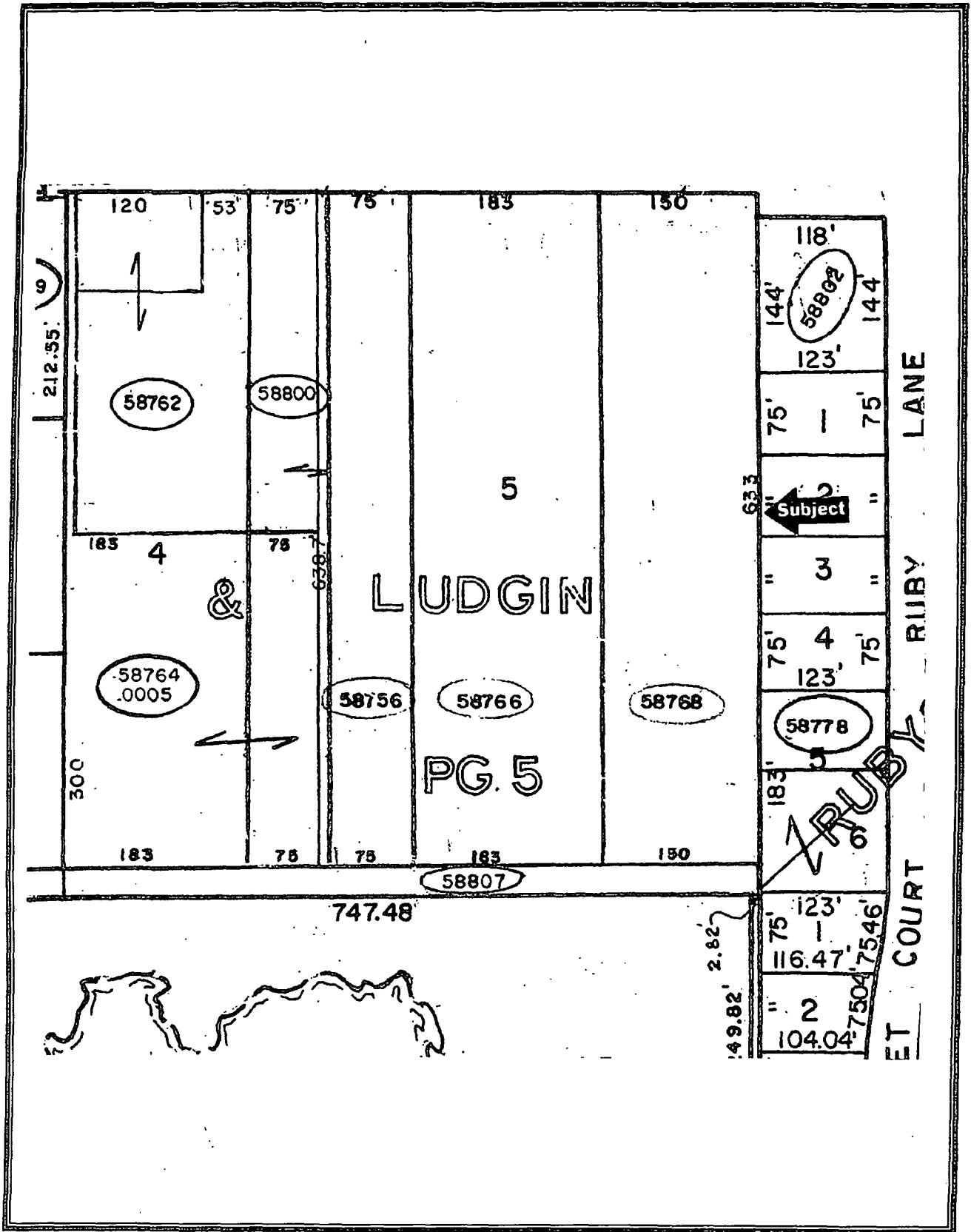

Tax Assessment Map

TOALE BROTHERS
P. O. DRAWER T
SARASOTA, FL 34230

\$2.24⁰
US POSTAGE
FIRST-CLASS
071V00717117
34236



000001067

first class

FDEP
P.O. Box 3070
Tallahassee, FL 32315-3070

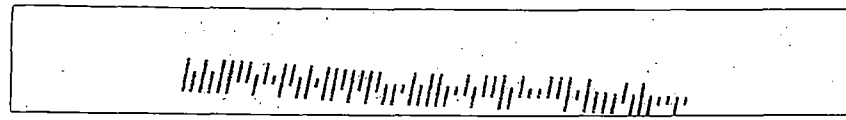

CLASS

