

HUMAN CREMATORIES AIR GENERAL PERMIT EXAMPLE REGISTRATION WORKSHEET

Facility Identification Number - If known (seven digit number)

_____ **0210121-001**

Registration Type

Check one:

INITIAL REGISTRATION - Notification of intent to:

- Construct and operate a proposed new facility.
 Operate an existing permitted facility not currently using an air general permit (e.g., a facility proposing to go from an air operation permit to an air general permit). If the facility currently holds one or more air operation permits, such permit(s) must be surrendered by the owner or operator upon the effective date of this air general permit. (See "Surrender of Existing Air Operation Permit(s)" below.)
 Operates an existing facility not currently permitted or using an air general permit.

RE-REGISTRATION (for facilities currently using an air general permit) - Notification of intent to:

- Continue operating the facility after expiration of the current term of air general permit use.
 Continue operating the facility after a change of ownership.
 Make an equipment change requiring re-registration pursuant to Rule 62-210.310(2)(e), F.A.C.
 Any other change not considered an administrative correction under Rule 62-210.310(2)(d), F.A.C.

Surrender of Existing Air Operation Permit(s) - For Initial Registrations Only, if Applicable

All existing air operation permits for this facility are hereby surrendered upon the effective date of this air general permit; specifically permit number(s):

General Facility Information

Facility Owner/Company Name (Name of corporation, agency, or individual owner who or which owns, leases, operates, controls, or supervises the facility.)

— **LEGACY OPTIONS, LLC**

Site Name (Name, if any, of the facility site; e.g., Plant A, Metropolis Plant, etc. If more than one facility is owned, a complete registration must be submitted for each.)

— **NONE**

Facility Location (Physical location of the facility, not necessarily the mailing address.)

Street Address: **4376 CORPORATE SQUARE, SUITE 1**
 City: **NAPLES** County: **COLLIER** Zip Code: **34104**

Facility Start-Up Date (Estimated start-up date of proposed new facility.)(N/A for existing facility.)

— **JANUARY 15, 2013**

RECEIVED
 SEP 18 2012
 DIVISION OF AIR
 RESOURCE MANAGEMENT

Facility Contact

Name and Position Title (Plant manager or person to be contacted regarding day-to-day operations at the facility.)
Print Name and Title: CLARENCE GLENN WITZENBURG, FUNERAL DIRECTOR

Facility Contact Telephone Numbers
Telephone: (239) 598-7722 Fax: (239) 254-0789
Cell phone: (239) 572-0655
E-mail: RICH. GOSSELIN @ EARTHLINK.NET

Facility Contact Mailing Address
Organization/Firm: LEGACY OPTIONS, LLC
Mailing Address: P.O. BOX 771570
City: NAPLES County: COLLIER Zip Code: 34107-1570

Correspondence Contact/Representative (to serve as additional Department contact)

Name and Position Title
Print Name and Title: RICHARD R. GOSSELIN, CFO

Correspondence Contact/Representative Telephone Numbers
Telephone: (239) 598-7722 Fax: (239) 254-0789
Cell phone: (207) 415-2800
E-mail: RICH. GOSSELIN @ EARTHLINK.NET

Correspondence Contact/Representative Mailing Address
Organization/Firm: LEGACY OPTIONS, LLC
Mailing Address: P.O. BOX 771570
City: NAPLES County: COLLIER Zip Code: 34107-1570

Government Facility Code (check only one)

Facility not owned or operated by a federal, state, or local government.

Facility owned or operated by the federal government.

Facility owned or operated by the state.

Facility owned or operated by the county.

Facility owned or operated by the municipality.

Facility owned or operated by a water management district.

Emission Unit Details

MANUFACTURER	MODEL NUMBER	SERIAL NUMBER	RATED CAPACITY
Mathews Cremation Division	IE43-PPII - Plus	Assigned when built - T.B.D.	175 lbs/hr

Design Calculations

If this is an initial registration for a proposed new human crematory unit, provide design calculations to confirm a sufficient volume in the secondary chamber combustion zone to provide for at least a 1.0 second gas residence time at 1800 degrees F.

- Design calculations attached.
- Registration is not for proposed new human crematory unit(s).

Helpful Definitions

"Biomedical Waste" - Any solid or liquid waste which may present a threat of infection to humans, including nonliquid-tissue, body parts, blood, blood products, and body fluids from humans and other primates; laboratory and veterinary wastes which contain human disease-causing agents; and discarded sharps. The following are also included:

1. Used absorbent materials saturated with blood, blood products, body fluids, or excretions or secretions contaminated with visible blood; and absorbent materials saturated with blood or blood products that have dried.
2. Non-absorbent, disposable devices that have been contaminated with blood, body fluids, or secretions or excretions visibly contaminated with blood, but have not been treated by a method listed in Section 381.0098, F.S., or a method approved pursuant to Rule 64E-16, F.A.C.

"Department" or "DEP" - The State of Florida Department of Environmental Protection.

"Emissions Unit" - Any part or activity of a facility that emits or has the potential to emit any air pollutant.

"Facility" - All of the emissions units which are located on one or more contiguous or adjacent properties, and which are under the control of the same person (or persons under common control).

"Human Crematory" - Any combustion apparatus used solely for the cremation of either human or fetal remains

"Owner" or "Operator" - Any person or entity who or which owns, leases, operates, controls or supervises an emissions unit or facility.

PLOT PLAN

[ALL INDUSTRIAL ZONE D AREA WITHIN 250' CIRCUMFERENCE]

NORTH



SHOW ALL SURROUNDING BUILDINGS AND ROADS WITHIN 250 FEET OF THE EQUIPMENT COVERED BY THIS APPLICATION.

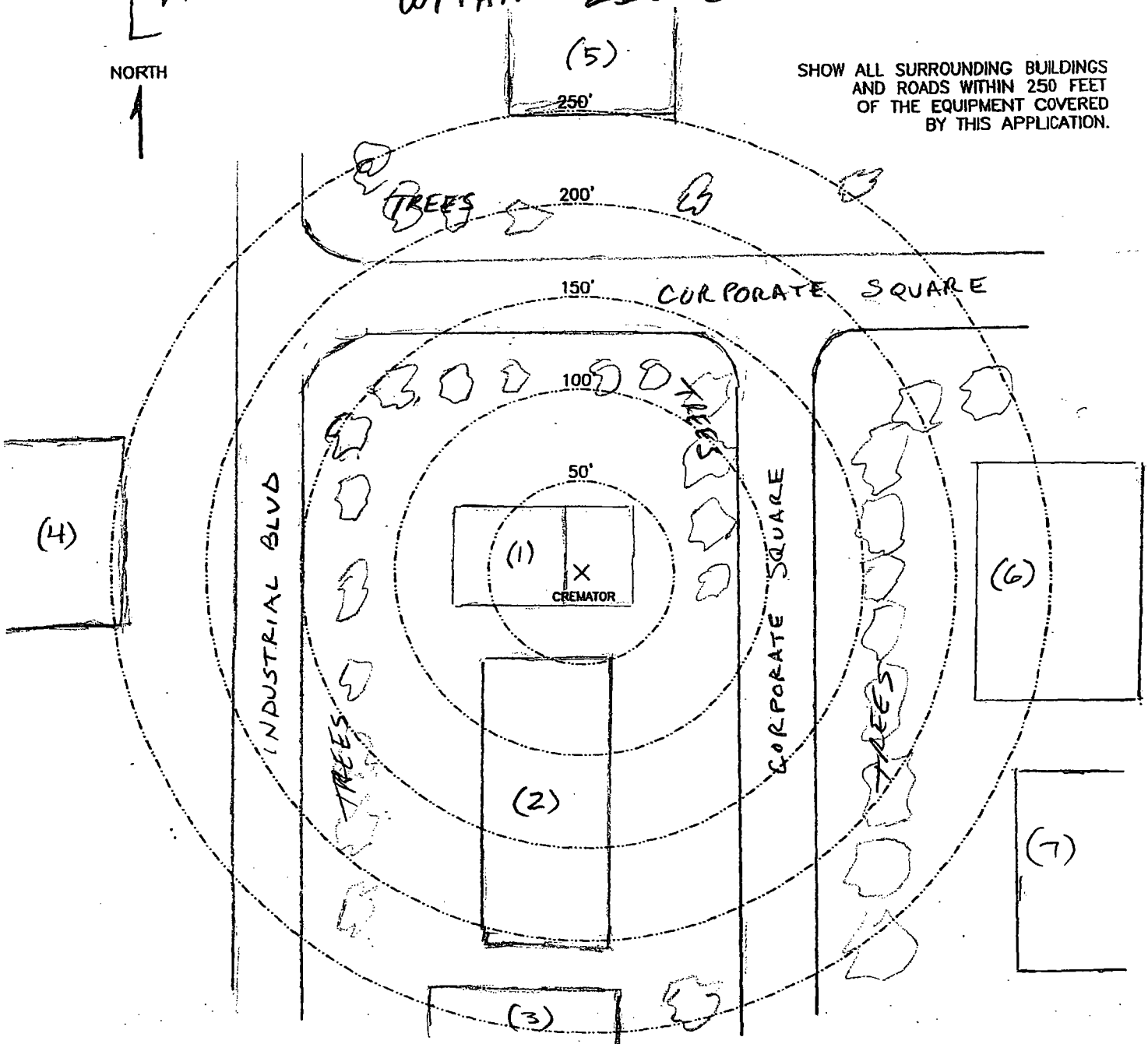

INSTRUCTIONS

1. INDICATE LOCATION AND TYPE OF BUILDING BY THE USE OF SMALL NUMBERED CIRCLES WITH THE DESCRIPTION BELOW.
2. SHOW ROADS AS LINES REPRESENTING THE ROAD EDGES. INDICATE STREET NAMES AND HIGHWAY NUMBERS.
3. SHOW WOODED OR CLEARED AREA BY APPROXIMATE BOUNDARY LINES AND THE WORDS "WOODS," "CLEARED," "CORNFIELD," ETC.

STRUCTURE DESCRIPTION

- (1) 4376 CORPORATE SQ - INDUSTRIAL
- (2) 4392 CORPORATE SQ - INDUSTRIAL
- (3) 4408 CORPORATE SQ - INDUSTRIAL
- (4) 222 INDUSTRIAL BLVD - INDUSTRIAL
- (5) 4360 CORPORATE SQ - INDUSTRIAL
- (6) 4361 CORPORATE SQ - INDUSTRIAL
- (7) 4395 CORPORATE SQ - INDUSTRIAL
- (8)
- (9)
- (10)

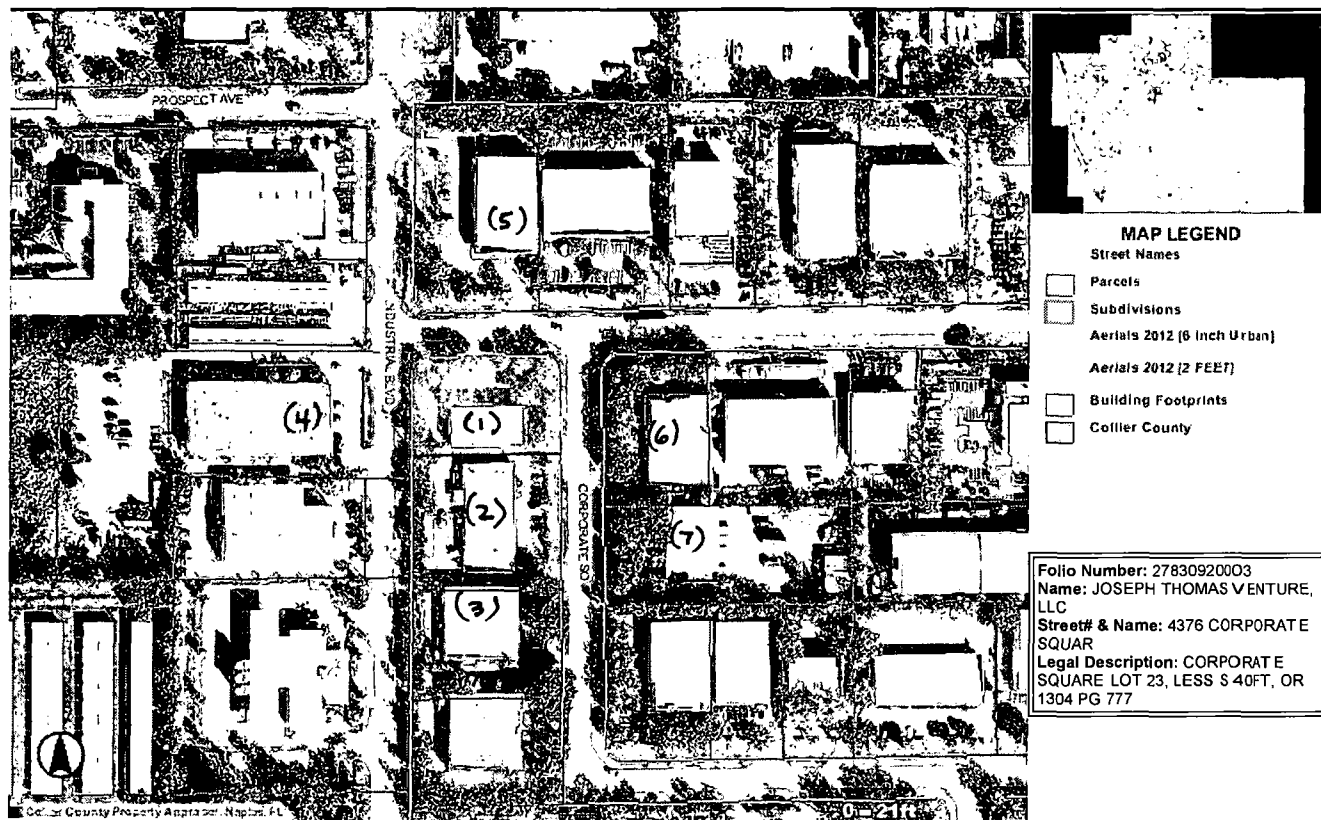

© 2004. Collier County Property Appraiser. While the Collier County Property Appraiser is committed to providing the most accurate and up-to-date information, no warranties expressed or implied are provided for the data herein, its use, or its interpretation.

PROCESS FLOW DIAGRAM CREMATOR

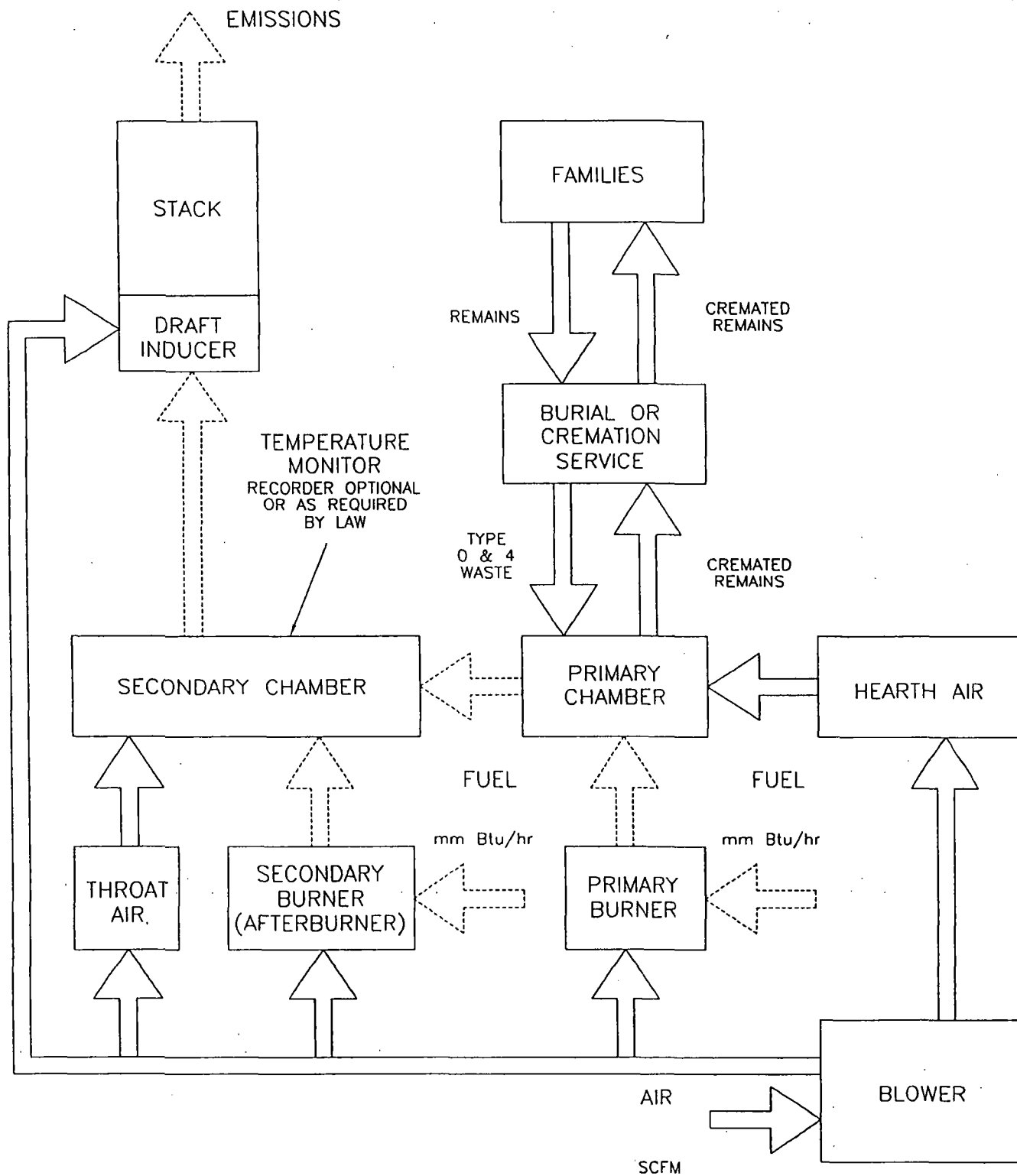

SPECIFICATIONS- Model Power-Pak II Plus

1. Equipment Type..... Model Power-Pak II Plus
 - A. Model No. IE43-PPII Plus
 - B. Underwriters Laboratories Listing and File No. ..

2. Dimensions
 - A. Footprint 13' – 6 ½ " x 5' - 7" (4.13 m x 1.7 m)
 - B. Maximum Length..... 15' – 8" (4.78 m)
 - C. Maximum Width 6' -9" (2.06 m)
 - D. Maximum Height 8' - 4" (2.54 m)
 - E. Chamber Loading Opening 25 ¾ " H x 43 ½ " W (654 mm x 1105 mm)

3. Weight 28,000 lbs. (12,700 kg)

4. Utility/Air Requirements
 - A. Gross Gas Input, Natural or LP Gas..... 2,000,000 BTU/hr. (2,110,112 kJ/h)
3,000,000 BTU/hr. (3,165,168 kJ/h) if operating
temperature is greater than 1,600° F (871° C)
 - Running Gas Pressure, Natural Gas..... 7 inches (177.8 mm) water column or greater
 - Running Gas Pressure, LP Gas 11 inches (279.4 mm) water column or greater
 - B. Electrical Supply..... 230 volt, 3Ø or 1Ø, 50/60 hz (other available)
 - C. Air Supply..... 2,500 cfm (70.8 standard m³/min)

5. Incineration Capacity 175 lbs./hr. (79 kg/h)

6. Typical Loading Capacity of Waste Types..... 750 lbs. (340.2 kg)

7. Construction and Safety Standards..... Incineration Institute of America, Underwriters
Laboratories, Canadian Standards Association

8. Steel Structure Construction
 - A. Frame 2" (51 mm) square tubing
 - B. Front/Rear Plates..... 3/8" (9.5 mm) plate
 - C. Floor Plates..... 3/16" (5 mm) plate
 - D. Outer Side Casing..... 12 gauge (3 mm) plate
 - E. Inner Side Casing..... 12 gauge (3 mm) plate

9. Stack Construction
 - A. Inner Wall..... 4 1/2" (110 mm) insulating firebrick or castable
 - B. Outer Wall 12 gauge (3 mm) sheet, 304 s.s., welded seams
(unlined stack available)

10. Draft Nozzle Construction Schedule 40 type 316 s.s. pipe, welded
connections

11. Main Chamber Door Construction
 - A. Steel Shell..... 3/16" (5 mm) steel, welded with reinforcement
 - B. Outer Refractory..... 1" (25 mm) insulating block
 - C. Inner Refractory 4½" (110 mm) insulating firebrick

SPECIFICATIONS- Model Power-Pak II Plus

12. Primary Chamber Wall Construction
- | | |
|-------------------------------------|------------------------------|
| A. Outer Casing Wall | 12 gauge (3 mm) sheet |
| B. Inner Frame/Air Compartment..... | 2" (51 mm) air compartment |
| C. Inner Casing Wall..... | 12 gauge (3 mm) sheet |
| D. Outer Refractory Wall..... | 5" (127 mm) insulating block |
| E. Inner Refractory Wall | 4½" (114 mm) firebrick |
13. Secondary Chamber Wall Construction
- | | |
|-------------------------------------|------------------------------|
| A. Outer Casing Wall | 12 gauge (3 mm) sheet |
| B. Inner Frame/Air Compartment..... | 2" (51 mm) air compartment |
| C. Inner Casing Wall..... | 12 gauge (3 mm) sheet |
| D. Outer Refractory Wall..... | 6" (152 mm) insulating block |
| E. Inner Refractory Wall | 4½" (114 mm) firebrick |
14. Refractory Temperature Ratings
- | | |
|--------------------------------------|---------------------|
| A. Standard Firebrick..... | 3,100° F. (1704° C) |
| B. Insulating Firebrick | 2,600° F. (1427° C) |
| C. Castable Refractory (Hearth)..... | 2,550° F. (1399° C) |
| D. Castable Refractory | 2,550° F. (1399° C) |
| E. Insulating Block | 1,900° F. (1038° C) |
| F. Bonding Mortar | 3,200° F. (1760° C) |
15. Chamber Volumes (not including external flues, stacks or chimneys)
- | | |
|----------------------------|--------------------------------------|
| A. Primary Chamber | 70 cubic feet (2.12 m ³) |
| B. Secondary Chamber | 96 cubic feet (2.72 m ³) |
16. Emission Control Features
- | | |
|--|----------|
| A. Secondary Chamber with Afterburner | Included |
| B. Opacity Monitor and Controller with Visual and Audible Alarms | Included |
| C. Auxiliary Air Control System..... | Included |
| D. Microprocessor Temperature Control System | Included |
17. Operating Temperatures
- | | |
|----------------------------|---|
| A. Primary Chamber..... | 32° F. - 1,800° F. (0° C - 982° C) |
| B. Secondary Chamber | 1,400° F. - 1,800° F. (760° C - 982° C) as required |
18. Secondary Chamber Retention Time
- > 1 second
19. Ash Removal
- Door functions as a heat shield. Sweep out beneath front door into hopper that fills collection pan.

SPECIFICATIONS- Model Power-Pak II Plus

- 20. Safety Interlocks
 - A. High Gas Pressure..... Optional
 - B. Low Gas Pressure..... Optional
 - C. Blower Air Pressure Included
 - D. Door Position Included
 - E. Opacity..... Included
 - F. Motor Starter Function..... Included
 - G. Chamber Temperature..... Included
 - H. Motor Overload Included
 - I. Flame Quality..... Included
 - J. Burner Safe Start Included

- 22. Burner Description The nozzle mix burners used on this cremation equipment are industrial quality and designed for incinerator use.

- 23. Ultraviolet Flame Detection Ultraviolet flame detection has proven to be the most reliable means of flame safety. The system is completely sealed in a quartz capsule to eliminate problems, caused by moisture and dust created in the cremation process, which effect flame rod detectors.

- 24. Operating Panel Indicating Lights
 - A. Safe Run..... Included
 - B. Door Closed Included
 - C. Pollution Alarm..... Included
 - D. Afterburner On (Secondary Burner)..... Included
 - E. Cremation Burner On..... Included
 - F. Low Fire Cremation Burner On..... Included
 - G. Afterburner (Secondary Burner) Reset..... Included
 - H. Cremation Burner Reset..... Included
 - I. Hearth Air..... Included
 - J. Throat Air Off Included

- 25. Automatic Timer Functions
 - A. Master Cycle Included
 - B. Afterburner (Secondary Burner) Included
 - C. Cremation Burner..... Included
 - D. Low Fire Cremation Burner Included
 - E. Hearth Air..... Included
 - F. Throat Air Included
 - G. Pollution Monitoring..... Included
 - H. Afterburner (Secondary Burner) Prepurge..... Included
 - I. Cremation Burner Prepurge Included
 - J. Cool Down Included

- 26. Exterior Finish
 - A. Primer 2 coats rust inhibiting
 - B. Finish 2 coats textured finish

SPECIFICATIONS- Model Power-Pak II Plus

- 27. Start-Up and Training..... Startup of cremation equipment and training of operators to properly operate and maintain the equipment is performed on-site under actual operating conditions. Included is a comprehensive owner's manual, with details on the equipment, its components and proper operation.

- 28. Environmental Submittals Complete technical portion of state environmental permits. Engineering calculations, technical data, existing stack test results and equipment blueprints provided.

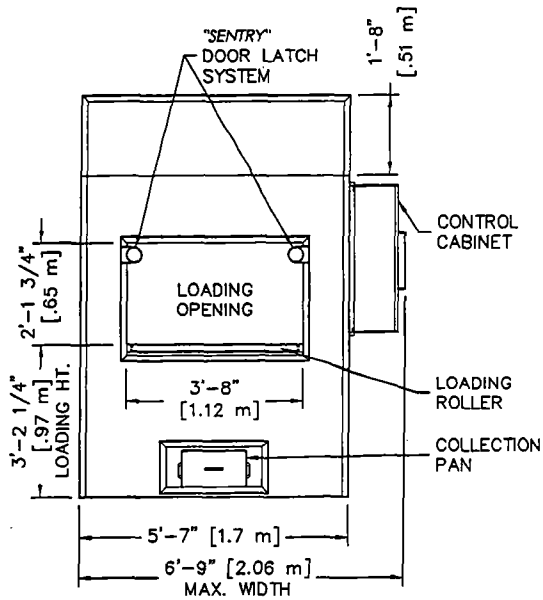

FRONT
ELEVATION

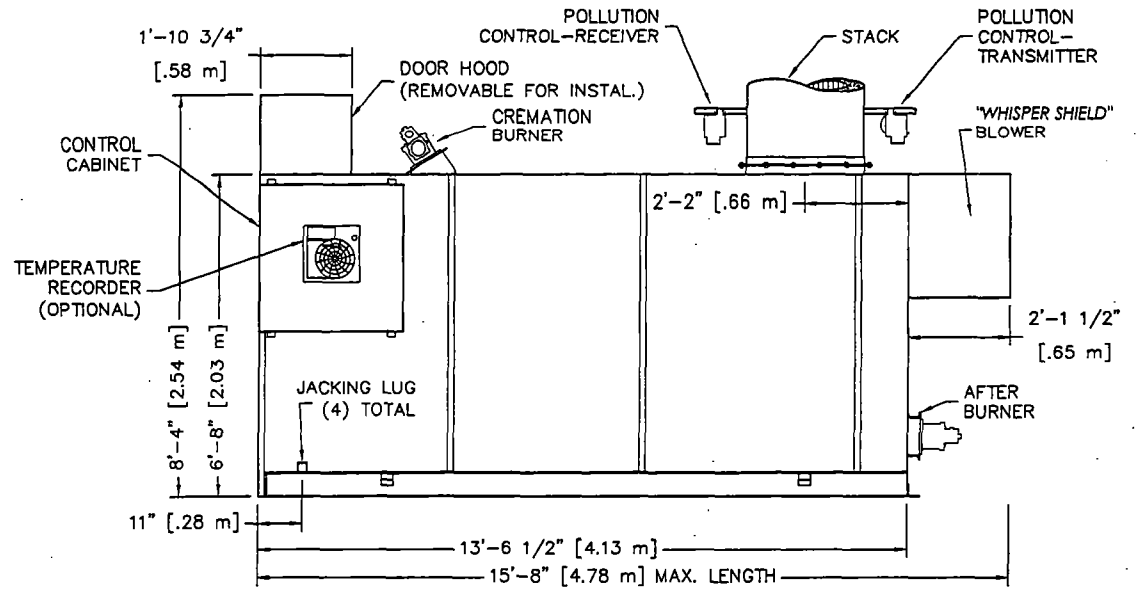

RIGHT SIDE
ELEVATION

NOTES:

- 1) CONTROL CABINET CAN BE MOUNTED ON THE LEFT OR RIGHT SIDE, OR REMOTELY.
- 2) CHAMBER WIDTH IS 43" [1.09m].

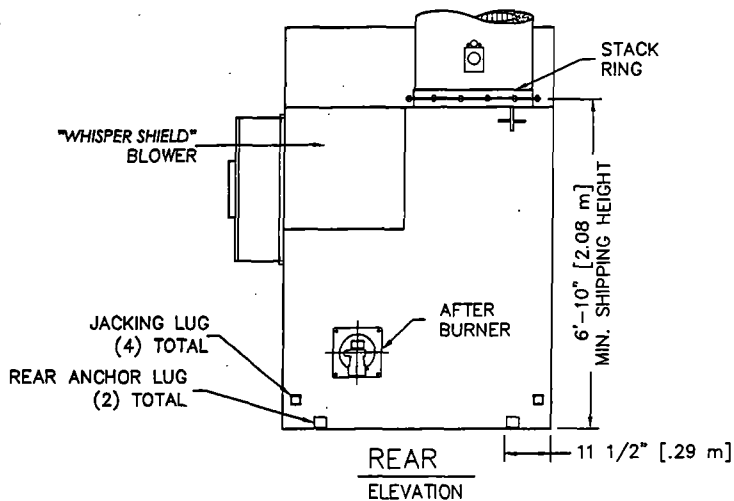

REAR
ELEVATION

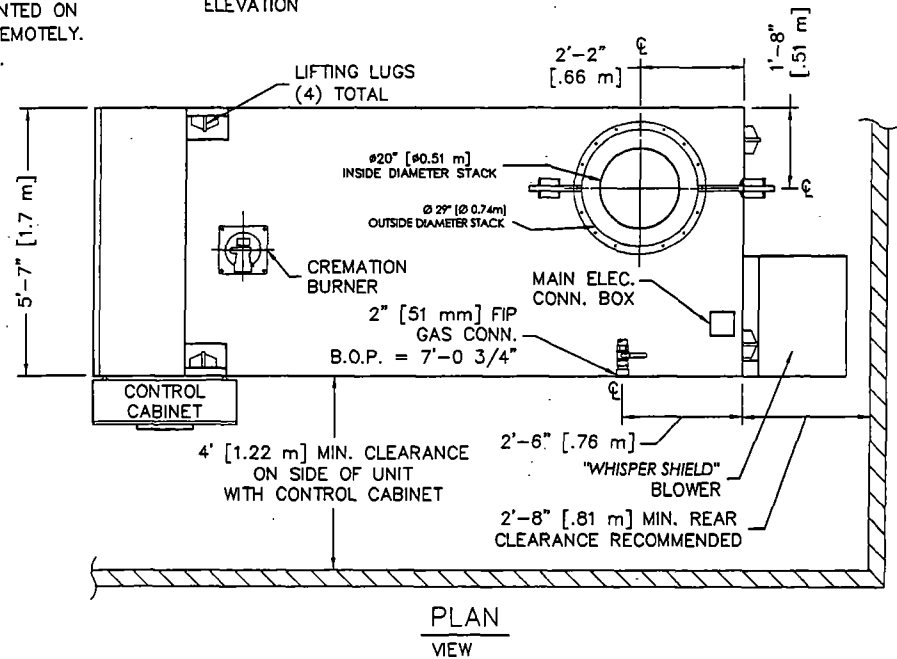

PLAN
VIEW

Matthews
CREMATION DIVISION
2045 Sprint Boulevard
Apopka, Florida 32703
USA

POWER-PAK II - PLUS

PLAN & ELEVATIONS INCL: CLEARANCES,
REQUIREMENTS & RECOMMENDATIONS

DATE:	06-12-12	SCALE:	1/4"=1'
DRAWN:	J.Gogel	PLOT SCALE:	1:48
APRVD:		SHEET:	1 OF: 2
DWG FILE:	PPII-PlusMarketingPlanElevR1S1		
DWG #:	0001081		

CREMATOR CLEARANCES

RECOMMENDED MINIMUM

TOP: ②	2 FEET [610 mm]	6 INCHES [152 mm]
CABINET SIDE:	4 FEET [1.22 m]	4 FEET [1.22 m]
OTHER SIDE:	2 FEET [610 mm]	6 INCHES [152 mm]
FRONT:	9 FEET [2.74 m]	8 FEET [2.44 m]
REAR:	3 FEET [0.91 m]	32 INCHES [812 mm]
STACK:	6 INCHES [152 mm]	6 INCHES [152 mm]

- FOR CLEARANCES OTHER THAN THOSE SHOWN, OR FOR SPECIAL REQUIREMENTS, CONSULT YOUR MCD REP.
- FROM HIGHEST POINT ON UNIT.
- CONTROL CABINET MOUNTS ON UNIT'S LEFT OR RIGHT SIDES, OR REMOTELY. (SEE PLAN VIEW, SHEET 1).
- REAR OF UNIT REFERS TO THE "BACK PLATE", RATHER THAN THE BACK OF THE "WHISPER SHIELD". (SEE PLAN VIEW, SHEET 1).

CREMATOR REQUIREMENTS

FUEL: A PRESSURE REGULATOR ADJUSTABLE TO 7" [178 mm] W.C. FOR NATURAL GAS, OR 11" [279 mm] W.C. FOR LP GAS.

CAPACITY: RANGES FROM 2.0 TO 3.0 MILLION BTU/HR [2.1 TO 3.1 MILLION KILOJOULES/HR] DEPENDING UPON AMOUNT OF BURNERS.

ELECTRICAL: 230 VOLT, 3Ø, (40A BREAKER) AND 115v (10A BREAKER), OR 230 VOLT, 1Ø, (70A BREAKER) AND 115v (10A BREAKER) 50/60 HERTZ

AIR: LOUVER NEAR THE REAR OF THE UNIT CAPABLE OF PASSING 2,500 CU FT/MIN [70.8 CU M/MIN] OF FREE AIR (36" X 36") [914 mm X 914 mm].

STACK INSTALLATION INSTRUCTIONS

- APPLY A 1/2" THICK MORTAR JOINT TO EXPOSED REFRACTORY SURFACE IN STACK RING. LOWER THE BASE STACK SECTION (B) ONTO STACK RING (A) AND FASTEN WITH HARDWARE PROVIDED (NO MORE THAN (2) STACK SECTIONS SHALL BE LIFTED TOGETHER). REPEAT PROCESS FOR REMAINING STACK SECTIONS. IF SECTIONS OF VARYING LENGTHS ARE SUPPLIED, ASSEMBLE AS TO AVOID FLANGES & LIFTING EYES INTERFERING WITH RAIN COLLAR LOCATION.
- INSTALL STORM COLLAR ON STACK, 3" [76 mm] ABOVE NON-COMBUSTIBLE LINER (FLASHING), ALLOWING FOR PROPER VENTILATION (SEE DETAIL).
- APPLY A 1/4" [6 mm] BEAD OF HIGH-TEMPERATURE SILICON SEALANT (PROVIDED BY MCD) TO THE JOINT BETWEEN THE STORM COLLAR (C) AND THE STACK (B).
- STORM COLLAR IS FURNISHED BY MCD. THE NON-COMBUSTIBLE LINER (FLASHING) TO BE PROVIDED BY THE OTHERS.
- IF FIFTY PERCENT OF THE STACK LENGTH IS ABOVE THE ROOF, GUY WIRES MAY BE REQUIRED. CONSULT WITH YOUR MCD REP.
- RAIN CAP NOT REQUIRED.

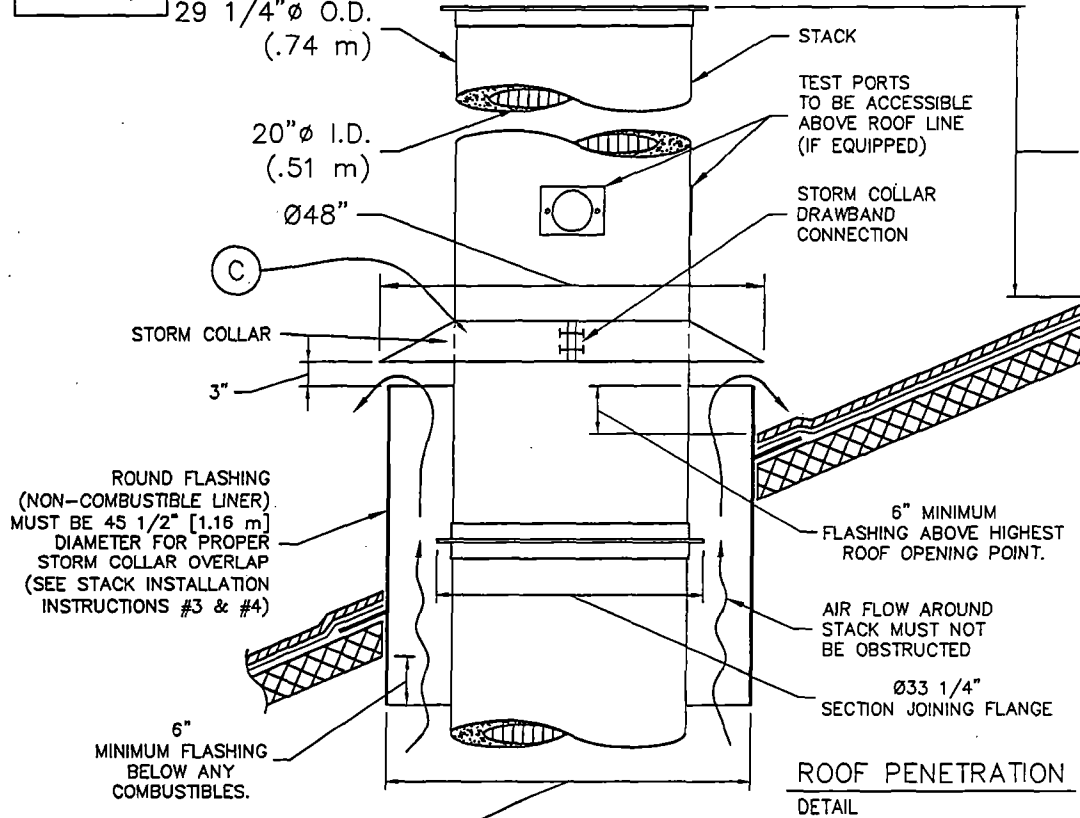

36" MINIMUM STACK ABOVE ROOF PEAK (MAY VARY BY LOCATION).

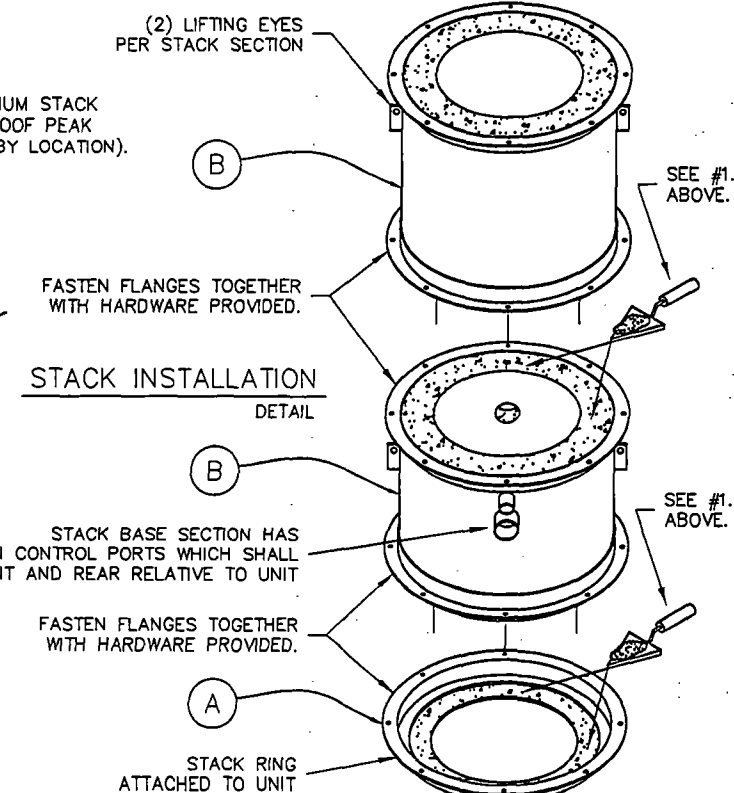

Ø45" REQUIRED FOR PROPER STACK CLEARANCE.

Matthews
CREMATION DIVISION

2045 Sprint Boulevard
Apopka, Florida 32703
USA

POWER-PAK II (PLUS)

STACK DETAILS, CLEARANCES & INSTALLATION INSTRUCTIONS.
REFRACTORY STACK DETAIL

DATE:	10-05-11	SCALE:	1/2"=1'
DRAWN:	JGogel	PLOT SCALE:	1:24
APRVD:		SHEET:	2 OF: 2
DWG FILE:	PPII-PlusMarketingStackRefS2		
DWG #:	0001089		

LEGEND OF SYMBOLS

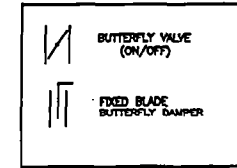

FLOW DIAGRAM

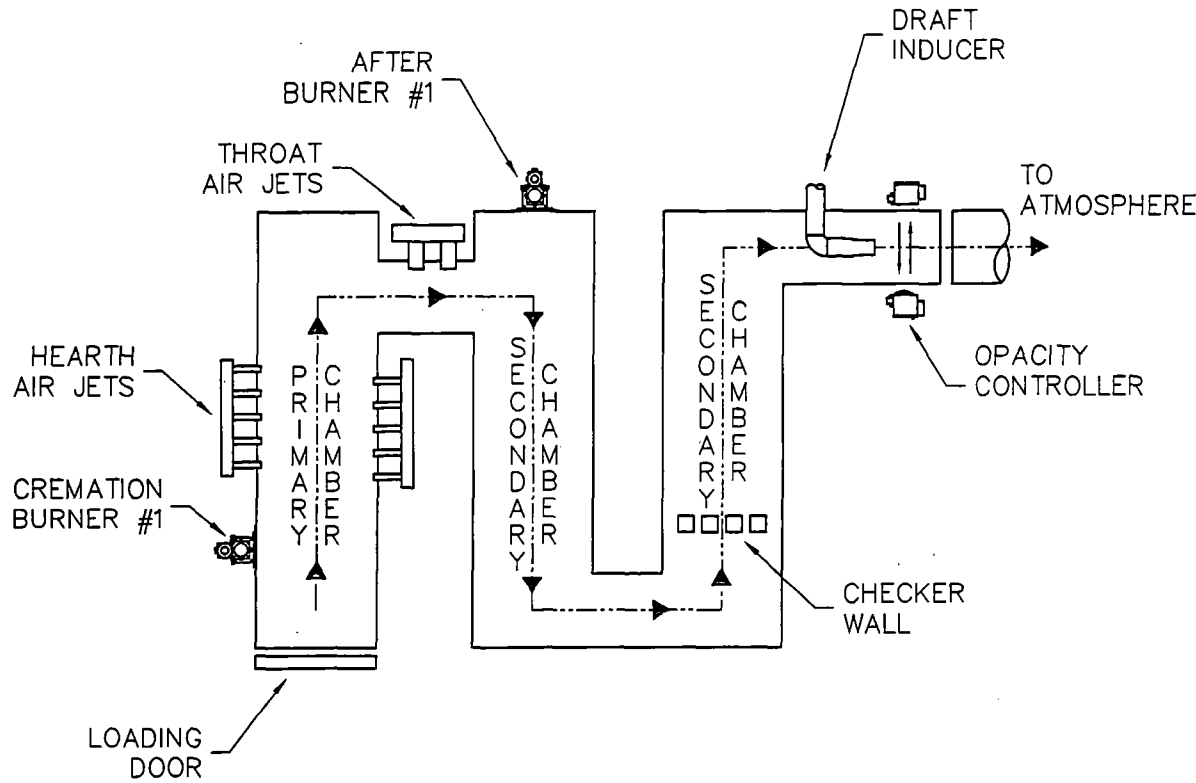

AIR SCHEMATIC

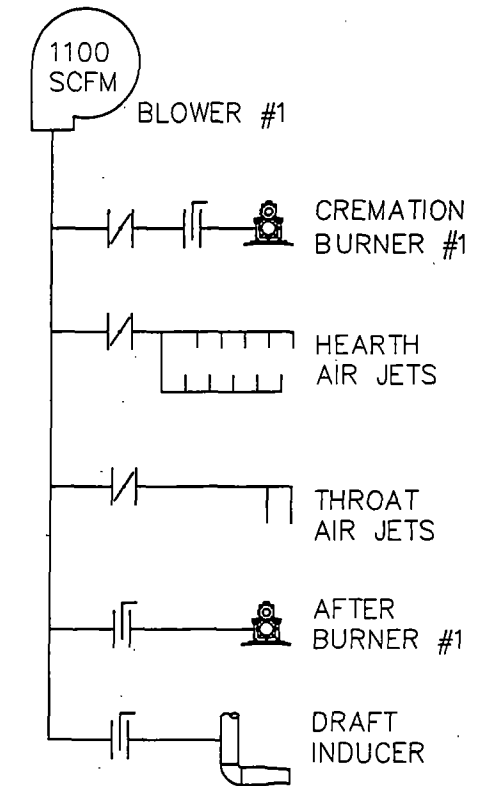

2045 Sprint Boulevard
Apopka, Florida 32703
USA

POWER PAK II PLUS

FLOW DIAGRAM
& AIR SCHEMATIC

DATE:	03-10-12	SCALE:	1/4"=1'
DRAWN:	MT	PLOT SCALE:	1:48
APRVD:		SHEET:	1 OF 1
DWG FILE:	PPII-PlusFlowDiaAirSchem		
DWG #:	0000523		

Calculation Of Emissions

Potential to Emit

Matthews Cremation Division (MCD)
 (formerly Industrial Equipment and Engineering Company (IEE))
 Crematory Incinerator Model IE43-PPII Plus

Total Incinerator Burn Capacity 175 lb/hr of remains (type 4) and associated containers (type 0)
 Flue gas flow rate = 1175 dscfm 12 Hours/Day X 6 Days/Week X 52 Weeks/Year
 (100 % Excess Air) = 3744 Hours/Year

Total Emission Rate = Incinerator Burn Rate X Emission Factor

Sulfur Dioxide (SO₂)

$$\frac{175 \text{ lb/hr X } 2.5 \text{ lb/ton X } 1 \text{ ton}}{2000 \text{ lbs}} = 0.219 \text{ lb/hr}$$

$$= 0.4095 \text{ TPY}$$

$$\frac{0.21875 \text{ lb/hr X } 4.54\text{E}+05 \text{ mg/lb X } 1 \text{ ppmv}}{1175 \text{ dscfm X } 60 \text{ min/hr X } 0.0283 \text{ m}^3/\text{F}^3 \text{ X } 2.61 \text{ mg/m}^3} = 19.07 \text{ ppmv}$$

Nitrogen Oxide (NOx - as Nitrogen Dioxide)

$$\frac{175 \text{ lb/hr X } 3 \text{ lb/ton X } 1 \text{ ton}}{2000 \text{ lbs}} = 0.2625 \text{ lb/hr}$$

$$= 0.4914 \text{ TPY}$$

$$\frac{0.2625 \text{ lb/hr X } 4.54\text{E}+05 \text{ mg/lb X } 1 \text{ ppmv}}{1175 \text{ dscfm X } 60 \text{ min/hr X } 0.028 \text{ m}^3/\text{F}^3 \text{ X } 1.88 \text{ mg/m}^3} = 32.11 \text{ ppmv}$$

Hydrocarbons (TOC/VOC - methane)

$$\frac{175 \text{ lb/hr X } 3 \text{ lb/ton X } 1 \text{ ton}}{2000 \text{ lbs}} = 0.2625 \text{ lb/hr}$$

$$= 0.4914 \text{ TPY}$$

$$\frac{0.2625 \text{ lb/hr X } 4.54\text{E}+05 \text{ mg/lb X } 1 \text{ ppmv}}{1175 \text{ dscfm X } 60 \text{ min/hr X } 0.0283 \text{ m}^3/\text{F}^3 \text{ X } 0.65 \text{ mg/m}^3} = 91.90 \text{ ppmv}$$

Lead (Pb)

(6.62E-05 lbs/cremation)

$$\frac{175 \text{ lb/hr X } 0.0000662 \text{ lb Pb}}{100 \text{ lb}} = 0.0001 \text{ lb/hr}$$

$$= 0.0002 \text{ TPY}$$

Particulates (PM & PM₁₀)

(Actual Levels lower as shown by test results)

$$\frac{175 \text{ lb/hr X } 7 \text{ lb/ton X } 1 \text{ ton}}{2000 \text{ lbs}} = 0.6125 \text{ lb/hr}$$

$$= 1.1466 \text{ TPY}$$

$$\frac{0.6125 \text{ lb/hr X } 7.00\text{E}+03 \text{ gr/lb X}}{1175 \text{ dscfm X } 60 \text{ min/hr}} = 0.06 \text{ gr/dscf}$$

Carbon Monoxide (CO)

(Actual Levels lower as shown by test results)

$$\frac{175 \text{ lb/hr X } 10 \text{ lb/ton X } 1 \text{ ton}}{2000 \text{ lbs}} = 0.875 \text{ lb/hr}$$

$$= 1.638 \text{ TPY}$$

$$\frac{0.875 \text{ lb/hr X } 4.54\text{E}+05 \text{ mg/lb X } 1 \text{ ppmv}}{1175 \text{ dscfm X } 60 \text{ min/hr X } 0.028 \text{ m}^3/\text{F}^3 \text{ X } 1.14 \text{ mg/m}^3} = 176.53 \text{ ppmv}$$

Notes:

1. Incinerator Emissions based on EPA emissions from Table 2.1-12 of AP-42 (5th Edition)
2. All conversion factors from AP-42 Appendix A.

CREMATOR MASS BALANCE
Matthews Cremation
PPII Plus

THESE CALCULATIONS HAVE BEEN PREPARED TO EVALUATE THE COMBUSTION PROCESS IN THIS UNIT.

THE INCINERATOR INSTITUTE OF AMERICA HAS PUBLISHED THE FOLLOWING SPECIFICATIONS COVERING AVERAGE WASTES.

WASTE TYPE	TYPE 0	TYPE 4
BTU PER POUND	8500	1000
POUND ASH PER POUND WASTE	0.05	0.05
POUND MOISTURE PER POUND WASTE	0.1	0.85
POUND COMBUSTIBLES PER POUND WASTE	0.85	0.1
HOURLY CONSUMPTION OF WASTE (LBS)	10	165

1. MASS OF PRODUCTS OF COMBUSTION FROM CONTAINER

A. COMBUSTION AIR

$$\frac{8500 \text{ BTU/LB}}{100 \text{ BTU/CF OF AIR}^*} \times 0.075 \text{ LB/CF OF AIR} = 6.38 \text{ LB/LB BURNED}$$

B. COMBUSTIBLES AND WATER VAPOR FROM CHART ABOVE = 0.95 LB/LB BURNED

C. TOTAL FLUE PRODUCT MASS PER LB BURNED = 7.33 LB/LB BURNED

2. MASS OF PRODUCTS OF COMBUSTION FROM BODY

A. COMBUSTION AIR

$$\frac{1000 \text{ BTU/LB}}{100 \text{ BTU/CF OF AIR}^*} \times 0.075 \text{ LB/CF OF AIR} = 0.75 \text{ LB/LB BURNED}$$

B. COMBUSTIBLES AND WATER VAPOR FROM CHART ABOVE = 0.95 LB/LB BURNED

C. TOTAL FLUE PRODUCT MASS PER LB BURNED = 1.70 LB/LB BURNED

SPECIFICATIONS	
PRIMARY BURNER FUEL CONSUMPTION (MMBTU/HR)	0.5
SECONDARY BURNER FUEL CONSUMPTION (MMBTU/HR)	0.9
ADDITIONAL SECONDARY AIR SUPPLIED (CFM)	200
SEC. CHAMBER OPERATING TEMPERATURE (°F)	1800
SECONDARY CHAMBER VOLUME (CU. FT)	96
SEC. CHAMB. CROSS-SECTIONAL AREA (SQ. FT)	2.76
FLAME PORT AREA (SQ. FT)	2.95
MIXING BAFFLES AREA (SQ. FT)	1.36

*AIR AT STANDARD CONDITIONS

3. TOTAL FLUE PRODUCTS

A. MAXIMUM PRIMARY BURNER GAS USAGE

$$500000 \text{ BTU/HR} \times 4.5\text{E-}05 \text{ LBS/BTU} = 22.5 \text{ LBS/HR}$$

B. COMBUSTION AIR FOR PRIMARY BURNER

$$\frac{500000 \text{ BTU/HR}}{100 \text{ BTU/CF AIR}} \times 1 \text{ Burner} \times 0.075 \text{ LB/CF AIR} = 375 \text{ LBS/HR}$$

C. MAXIMUM SECONDARY BURNER GAS USAGE

$$900000 \text{ BTU/HR} \times 4.5\text{E-}05 \text{ LBS/BTU} = 41 \text{ LBS/HOUR}$$

D. COMBUSTION AIR FOR SECONDARY BURNER

$$\frac{900000 \text{ BTU/HR}}{100 \text{ BTU/CF AIR}} \times \frac{1}{\text{Burner}} \times 0.075 \text{ LB/CF AIR} = 675 \text{ LBS/HOUR}$$

E. PRODUCTS FROM TYPE 0 WASTE (CONTAINER)

$$7.33 \text{ LBS/LB BURNED} \times 10 \text{ LB/HR BURN RATE} = 73 \text{ LBS/HOUR}$$

F. PRODUCTS FROM TYPE 4 WASTE (TISSUE)

$$1.70 \text{ LBS/LB WASTE} \times 165 \text{ LB/HR BURN RATE} = 281 \text{ LBS/HOUR}$$

G. ADDITIONAL SECONDARY CHAMBER COMBUSTION AIR (THROAT AIR)

$$12000 \text{ CF/HR}^* \times 0.075 \text{ LB/CF AIR} = 900 \text{ LBS/HOUR}$$

H. TOTAL FLUE PRODUCTS

$$= \underline{\underline{2367 \text{ LBS/HOUR}}}$$

2. VELOCITY AND TIME CALCULATIONS

A. SCFM CALCULATION

(PRODUCTS ASSUMED TO HAVE DENSITY CLOSE TO AIR)

$$2367 \text{ LBS/HR} \times \frac{13.35 \text{ STD. CU. FT/LB}}{60 \text{ MIN/HR}} = 527 \text{ SCFM}$$

B. TOTAL PRODUCTS ACFM @ 1800 °F

$$\frac{2260 \text{ °RANKINE}}{530 \text{ °RANKINE}} \times 526.6 \text{ CFM} = 2246 \text{ ACFM}$$

C. RETENTION TIME

$$\frac{96 \text{ CU. FT}}{2246 \text{ ACFM}} \times \frac{60 \text{ SECONDS}}{1 \text{ MINUTE}} = 2.57 \text{ SECONDS}$$

D. VELOCITY IN FLAME PORT

$$\frac{2246 \text{ ACFM}}{2.95 \text{ SQ. FT}} \times \frac{1 \text{ MINUTE}}{60 \text{ SECONDS}} = 12.7 \text{ FEET/SECOND}$$

E. VELOCITY AT MIXING BAFFLES

$$\frac{2246 \text{ ACFM}}{1.36 \text{ SQ. FT}} \times \frac{1 \text{ MINUTE}}{60 \text{ SECONDS}} = 27.5 \text{ FEET/SECOND}$$

F. VELOCITY IN SECONDARY CHAMBER

$$\frac{2246 \text{ ACFM}}{2.76 \text{ SQ. FT}} \times \frac{1 \text{ MINUTE}}{60 \text{ SECONDS}} = 13.6 \text{ FEET/SECOND}$$

Legacy Options, LLC

P.O. Box 771570
Naples, FL 34107-1570
(239)598-7722

September 13, 2012

FDEP Receipts
Attn: Dick Dibble
P.O. Box 3070
Tallahassee, FL 32315-3070

Dear Mr. Dibble:

We are starting-up a funeral establishment and will be installing a new human cremation unit that will be manufactured by Matthews International. We are hopeful that the installation of the equipment will occur in time for us to commence operations in January, 2013.

We enclose our Air General Permit Example Registration Worksheet, and a check for \$100. If you need any other information in addition to what we have enclosed, please contact me with your requests.

Sincerely,

A handwritten signature in black ink, appearing to read "Richard R. Gosselin", with a long horizontal flourish extending to the right.

Richard R. Gosselin, CFO

Encl: (17 pages), and check

HUMAN CREMATORIES

Air General Permit Example Registration Worksheet

The Department of Environmental Protection (“Department” or “DEP”) has established an “air general permit” at Florida Administrative Code (“F.A.C.”) Rule 62-210.310(5)(c) for human crematories. An air general permit is an authorization by rule to construct or operate a specific type of air pollutant emitting facility. Use of such authorization by any individual facility does not require action by the Department. The terms and conditions of the air general permit are set forth in the rule, rather than in a separately issued air construction or air operation permit.

If you are the owner or operator of an eligible facility comprising one or more human crematories, you may register to use the air general permit at Rule 62-210.310(5)(c), F.A.C., by following the general procedures given at subsections 62-210.310(2) and 62-210.310 (5), F.A.C. To register, use the Department’s electronic registration system (currently under development) or submit all the information specified in the above rules to either of the following addresses, along with the air general permit registration processing fee (\$100.00), payable to FDEP.

Regular USPS Mail Delivery

Department of Environmental Protection
Receipts
Post Office Box 3070
Tallahassee, Florida 32315-3070

or

Overnight Delivery (FedEx, UPS, DHL, etc.)

Department of Environmental Protection
3800 Commonwealth Blvd.
Mail Station 77
Tallahassee, Florida 32399

If you properly register to use an air general permit, and are not denied use of the air general permit by the Department, you are authorized to construct and operate the facility in accordance with the general terms and conditions of Rule 62-210.310, F.A.C., and the specific terms and conditions of Rule 62-210.310(5)(c), F.A.C. Your facility may vary, so be sure your registration describes the operations at your facility in sufficient detail to demonstrate the facility’s eligibility for use of the air general permit and to provide a basis for tracking any future equipment or process changes. Your registration should describe all air pollutant-emitting processes and equipment at the facility, and it should identify any air pollution control measures or equipment used.

The rules do not require any specific format for the registration. This worksheet, however, has been designed to assist owners and operators. Using it as a template for a general permit registration will help ensure that all necessary information is submitted.

Additional information can be found on the Department’s air general permit program website (http://www.floridadep.org/air/emission/air_gp.htm) or by calling the Small Business Environmental Assistance Program Hotline at 1-800-SBAP-HLP (1-800-722-7457).